

HITACHI HI-FI COMPONENT PRE-MAIN AMPLIFIER

MODEL IA-600

SERVICE MANUAL



IA - 6 0 0

No. 34

1971

1. SPECIFICATIONS

Type:	SOLID STATE STEREO AMPLIFIER	Remaining noise:	0.3mV
Circuit system:	Complementary SEPP regulated current drive system OTL circuitry	Dumping factor:	50 (8Ω)
Semi-conductor:	IC: 2, Transistor: 19, Diode: 13	Tone control characteristic:	BASS ±12dB (100Hz) TREBLE ±12dB (10kHz)
Music power:	100W (8Ω)	Hi-filter characteristic:	-8dB (10kHz)
Practical output:	32W/32W (8Ω)	Loudness characteristic:	+10dB (50Hz), +4dB (10kHz)
Rate of all higher harmonic distortion:	28W/28W - 0.1% (8Ω)	Channel separation:	50dB (1kHz)
Rate of mixed modulation distortion:	Rating output—at 3dB 0.07% 0.15% (60Hz: 7kHz = 4 : 1)	Equalizer characteristic:	RIAA ±0.5dB
Frequency characteristic:	20Hz ~ 20kHz (within -1dB)	Accessory functions:	PHONO Sensitivity change-over switch, DIN recording connector, stereo headphone jack, MIC jack, PRE-MAIN detachable terminal
Input sensitivity:	PHONO HIGH 6mV(50kΩ) LOW 2.5mV(50kΩ) AUX - 1,2 250mV(100kΩ) TUNER 250mV(100kΩ) MIC 2.5mV(25kΩ) TAPE IN 250mV	Rating power consumption:	120V/60Hz 120W for U.S.A. standard 120V/60Hz 87W for CANADA standard 220V, 50/60Hz 120W 240V, 50/60Hz 120W
Signal-to-noise ratio:	PHONO 68dB AUX - 1,2 75dB TUNER 75dB MIC 68dB TAPE IN 75dB	Cabinet dimensions:	412(W) x 122(H) x 313(D)mm (16 ² / ₈ x 4 ⁶ / ₈ x 12 ³ / ₈ in)
		Weight:	8.8kg (19.4 lbs.)

2. FEATURES

1. Noise has been reduced to the minimum and S/N (signal-to-noise) ratio has been further improved, because of the adoption of high-performance, low-noise type hybrid IC (Integrated Circuits) in the equalizer section.
2. Since the tone control uses the NF type step-system, tone effect can be clearly perceived.
3. Complementary ITL, OTL circuits of constant-current drive system and Hitachi high-performance silicone transistors have realized lowest distortion and minimum noise.
4. MIC jack is very convenient for those who comment on record concerts or study foreign languages.
5. Handling is easy and convenient by the adoption of an input sensitivity change-over switch on the PHONO and a speaker change-over switch on the PHONO and a speaker change-over switch.
6. It is possible to use this model for various purposes, because the IA-600 is equipped with a pre-main detachable terminal.
7. The one-touch system of speaker connection terminal makes speaker connection easier.

3. NAMING OF COMPONENTS

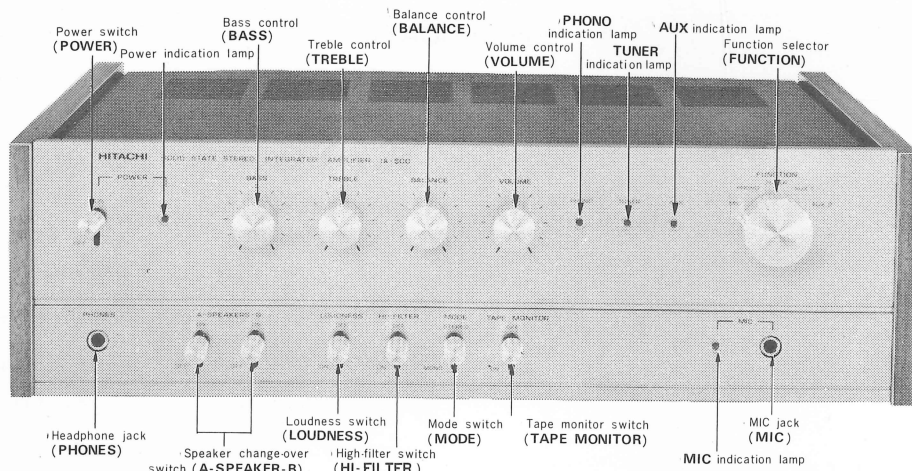

Fig. 1 FRONT PANEL

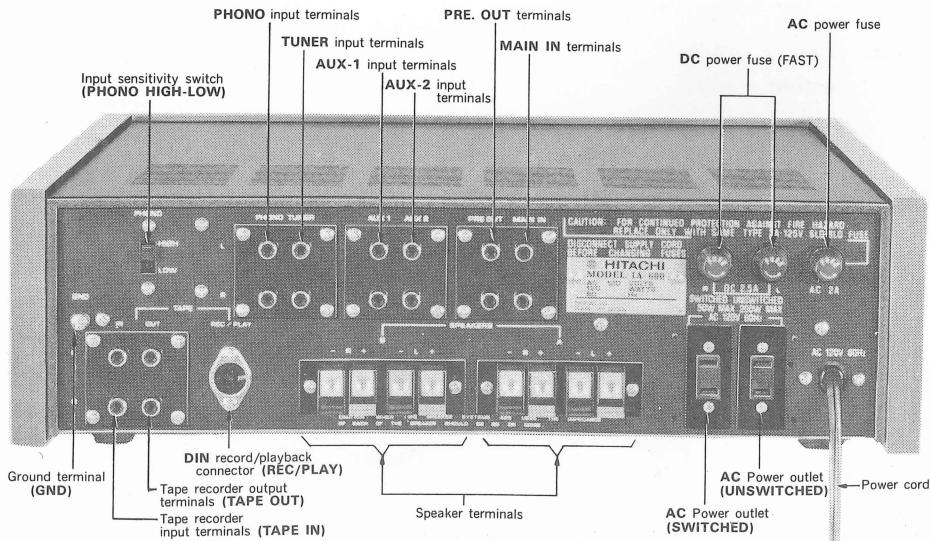

Fig. 2 REAR PANEL

4.4 Arrangement of rotary switch's terminals

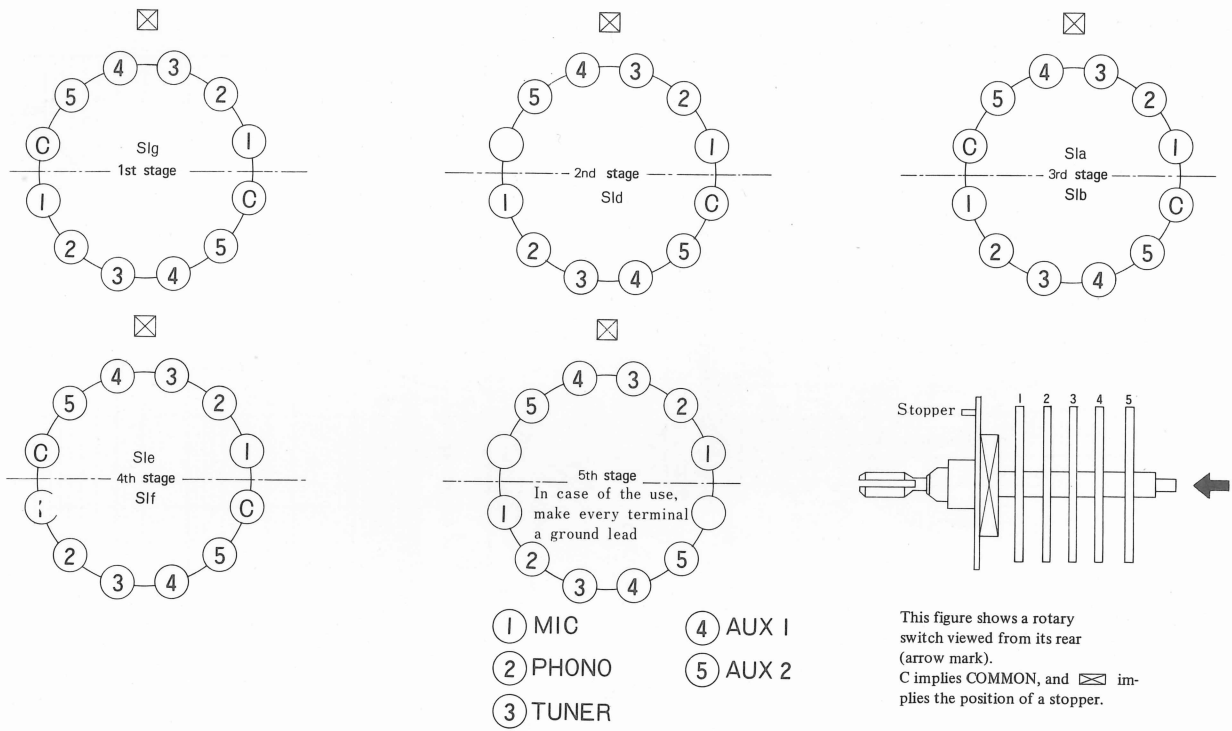

Fig. 6

5. CHASSIS LAYOUT

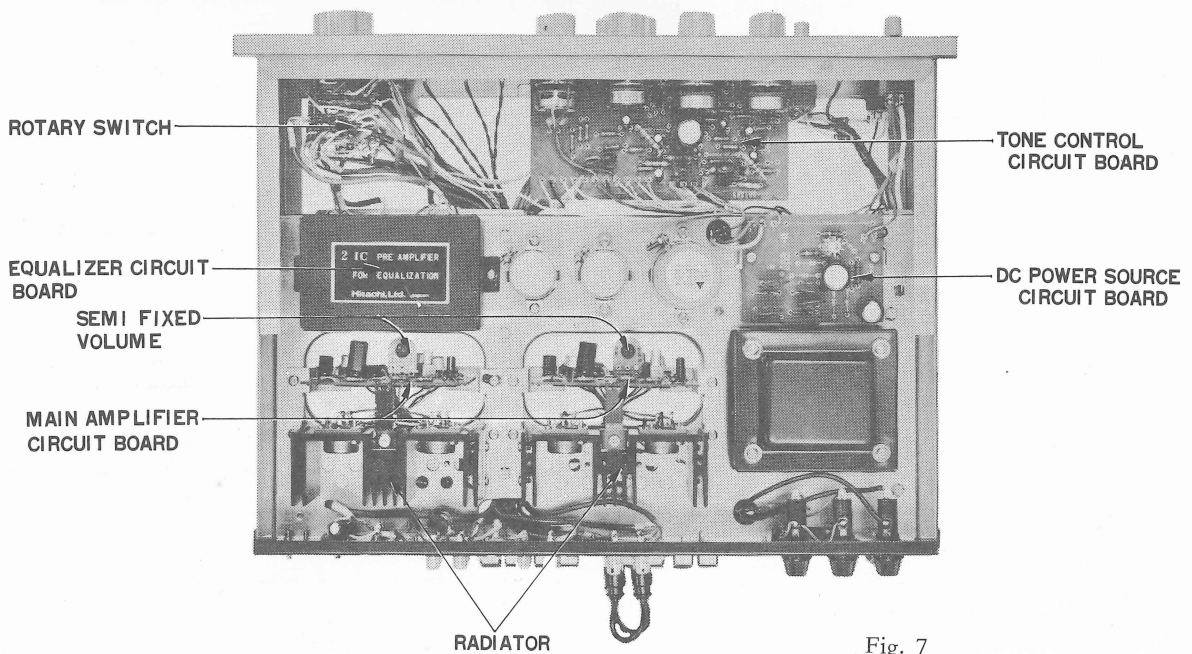
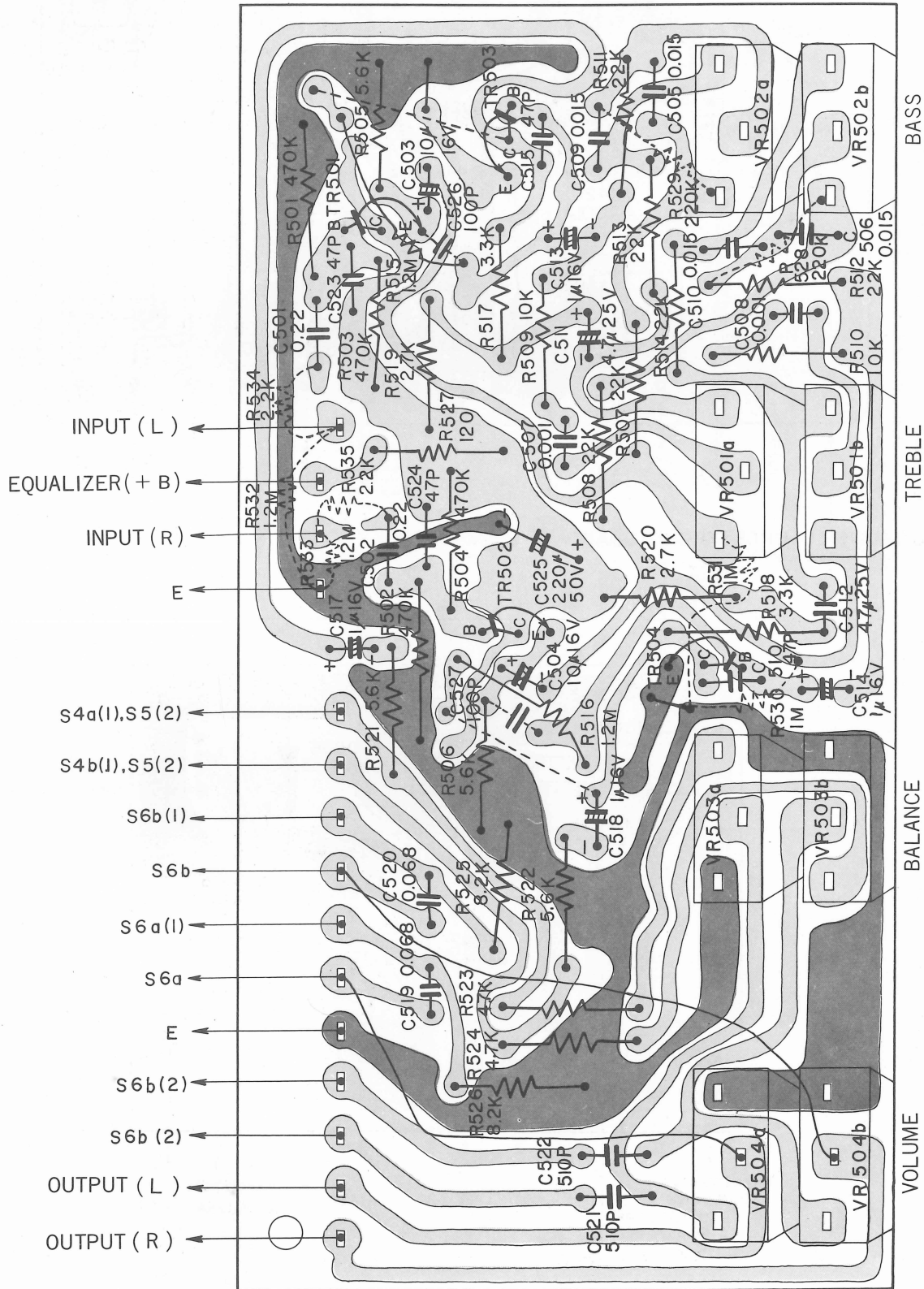

Fig. 7

7. CIRCUIT BOARD

TONE CONTROL CIRCUIT BOARD



MODEL IA-600 SERVICE MANUAL

EQUALIZER CIRCUIT BOARD

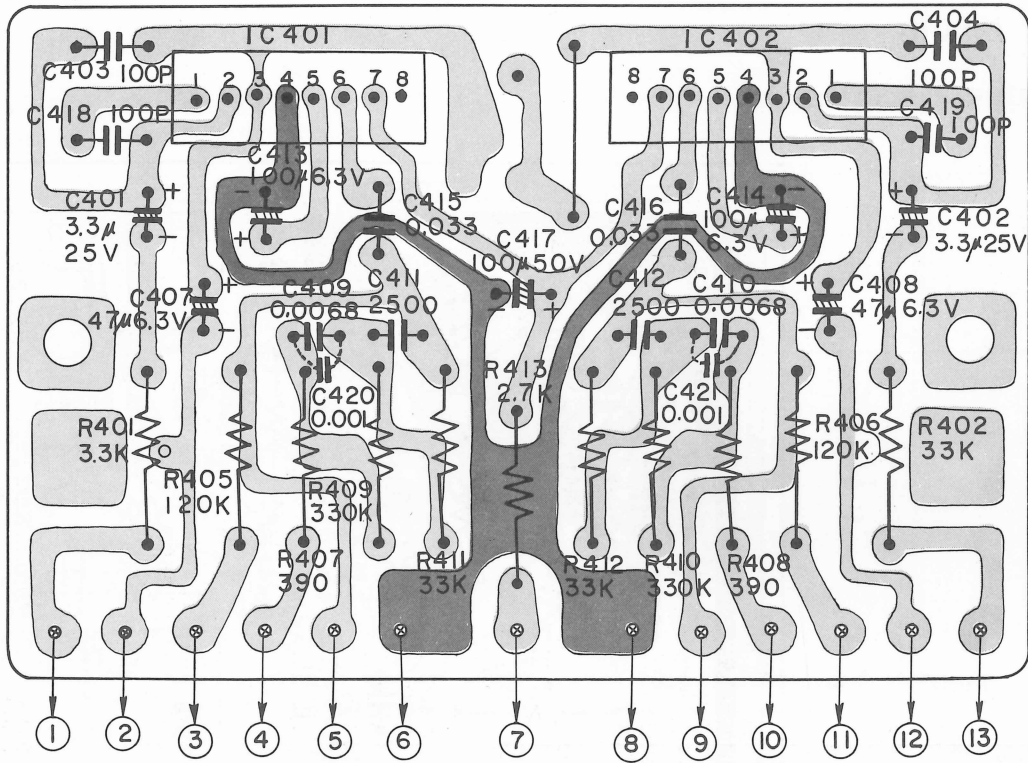

DC POWER SOURCE CIRCUIT BOARD

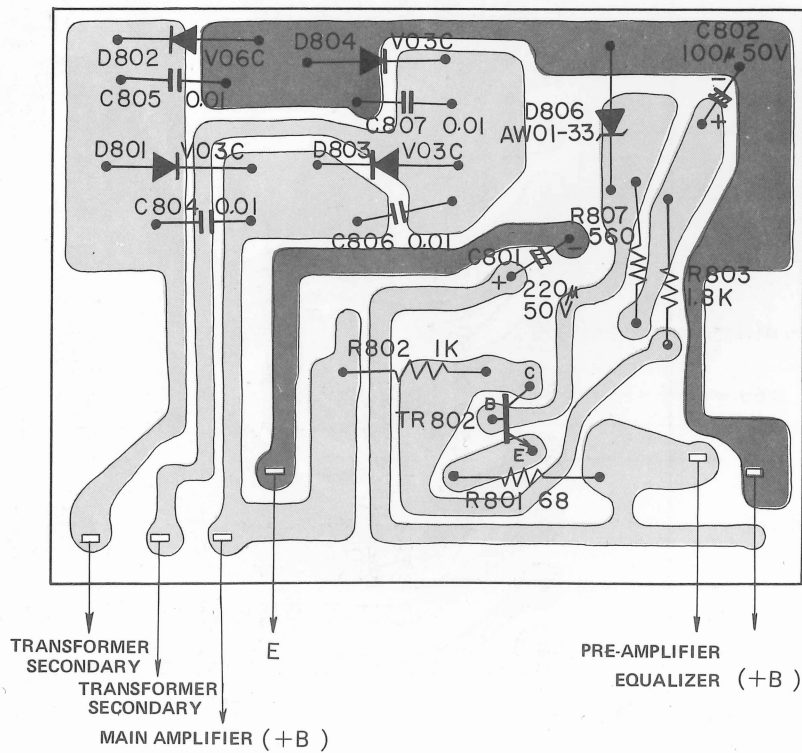

MAIN AMPLIFIER CIRCUIT BOARD

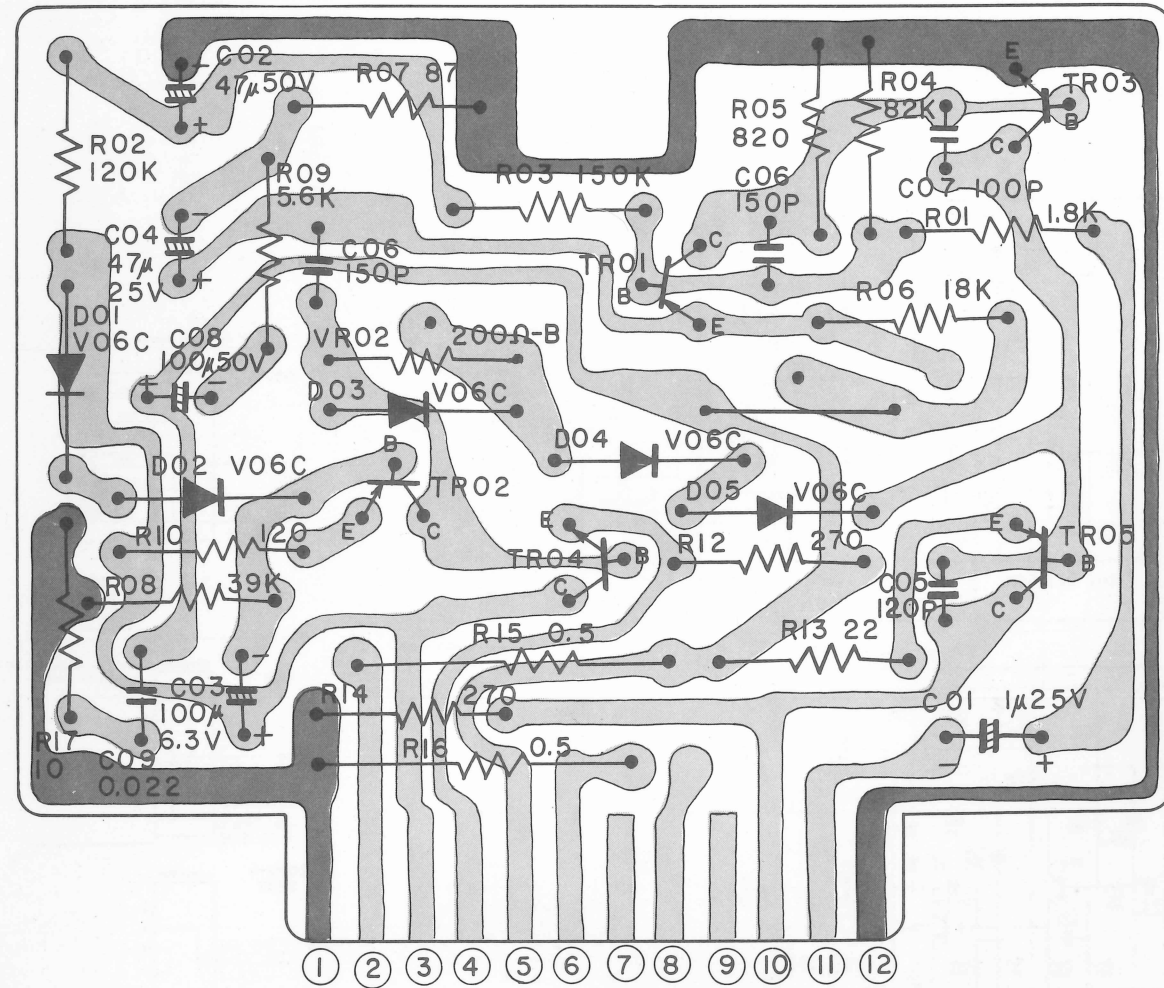

DIN CIRCUIT BOARD

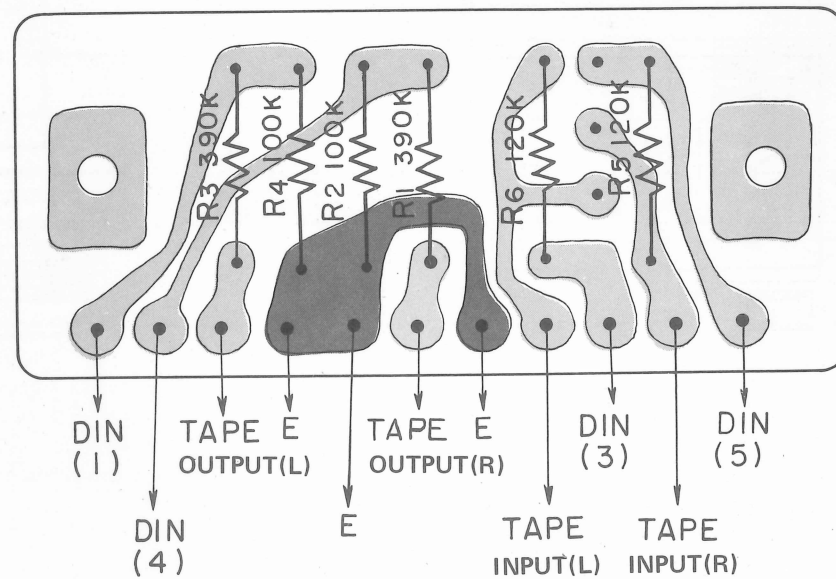

9. REPLACEMENT PARTS LIST

SYMBOL NO.	STOCK NO.	DESCRIPTION		SYMBOL NO.	STOCK NO.	DESCRIPTION	
CAPACITORS - FOR EQUALIZER CIRCUIT BOARD							
CAPACITORS							
C401	0257049	electrolytic	3.3μF	25V	C701	0252611	electrolytic 1μF 25V
C402	0257049	electrolytic	3.3μF	25V	C702	0252825	electrolytic 47μF 50V
C403	0248724	ceramic, discal	100pF	K	C703	0252231	electrolytic 100μF 6.3V
C404	0248724	ceramic, discal	100pF	K	C704	0252125	electrolytic 47μF 25V
C407	0252225	electrolytic	47μF	6.3V	C705	0248726	ceramic, discal 120pF K
C408	0252225	electrolytic	47μF	6.3V	C706	0248728	ceramic, discal 150pF K
C409	0274016	mylar, film	0.0068μF	K	C707	0248724	ceramic, discal 100pF K
C410	0274016	mylar, film	0.0068μF	K	C708	0252831	electrolytic 100μF 50V
C411	0221512	mylar, film	2500pF	J	C709	0275013	mylar, film 0.022μF K
C412	0221512	mylar, film	2500pF	J	FOR DC POWER SOURCE CIRCUIT BOARD		
C413	0252231	electrolytic	100μF	6V	C801	0252832	electrolytic 220μF 50V
C414	0252231	electrolytic	100μF	6V	C802	0252831	electrolytic 100μF 50V
C415	0275014	mylar, film	0.0033μF	K	C804	0245408	ceramic, discal 0.01μF 500V
C416	0275014	mylar, film	0.0033μF	K	C805	0245408	ceramic, discal 0.01μF 500V
C417	0252831	mylar, film	100μF	50V	C806	0245408	ceramic, discal 0.01μF 500V
C418	0248724	ceramic, discal	100pF	K	C807	0245408	ceramic, discal 0.01μF 500V
C419	0248724	ceramic, discal	100pF	K	for Chassis assembly		
FOR TONE CONTROL CIRCUIT BOARD							
C501	0276013	mylar, film	0.22μF	K	C 1	0252125	electrolytic 47μF 6.3V
C502	0276013	mylar, film	0.22μF	K	C 2	0252125	electrolytic 47μF 6.3V
C503	0252521	electrolytic	10μF	16V	C 3	0259810	electrolytic 1000μF 50V
C504	0252521	electrolytic	10μF	16V	C 4	0259810	electrolytic 1000μF 50V
C505	0275012	mylar, film	0.015μF	K	C 5	0259797	electrolytic 2200μF 90V
C506	0275012	mylar, film	0.015μF	K	C 7	0274016	mylar, film 0.0068μF K
C507	0274011	mylar, film	0.001μF	K	C 8	0274016	mylar, film 0.0068μF K
C508	0274011	mylar, film	0.001μF	K	C 12	0243873	ceramic, discal 0.0047μF 500V
C509	0275012	mylar, film	0.015μF	K	C 13	0275011	mylar, film 0.01μF K
C510	0275012	mylar, film	0.015μF	K	C 14	0275011	mylar, film 0.01μF K
C511	0252615	electrolytic	4.7μF	25V	RESISTORS-FOR EQUALIZER CIRCUIT BOARD		
C512	0252615	electrolytic	4.7μF	25V	RESISTORS		
C513	0252511	electrolytic	1μF	16V	R401	1114467	carbon, film 3.3kΩ K SRD¼P
C514	0252511	electrolytic	1μF	16V	R402	1114467	carbon, film 3.3kΩ K SRD¼P
C515	0248716	ceramic, discal	47pF	K	R405	1114542	carbon, film 120kΩ K SRD¼P
C516	0248716	ceramic, discal	47pF	K	R406	1114542	carbon, film 120kΩ K SRD¼P
C517	0252511	electrolytic	1μF	16V	R407	1114448	carbon, film 390Ω K SRD¼P
C518	0252511	electrolytic	1μF	16V	R408	1114448	carbon, film 390Ω K SRD¼P
C519	0275016	mylar, film	0.068μF	K	R409	1114547	carbon, film 330Ω K SRD¼P
C520	0275016	mylar, film	0.068μF	K	R410	1114547	carbon, film 330Ω K SRD¼P
C521	0221328	styrol	510pF	J	R411	1114526	carbon, film 27kΩ K SRD¼P
C522	0221328	styrol	510pF	J	R412	1114526	carbon, film 27kΩ K SRD¼P
C523	0248716	ceramic, discal	47pF	K	R413	1114466	carbon, film 2.7kΩ K SRD¼P
C524	0248716	ceramic, discal	47pF	K	FOR MAIN AMPLIFIER CIRCUIT BOARD		
C525	0252832	electrolytic	220μF	50V	C601	0252611	electrolytic 1μF 25V
C526	0248724	ceramic, discal	100pF	K	C602	0252825	electrolytic 47μF 50V
C527	0248724	ceramic, discal	100pF	K	C603	0252231	electrolytic 100μF 6.3V
FOR MAIN AMPLIFIER CIRCUIT BOARD							
C601	0252611	electrolytic	1μF	25V	C604	0252125	electrolytic 47μF 25V
C602	0252825	electrolytic	47μF	50V	C605	0248726	ceramic, discal 120pF K
C603	0252231	electrolytic	100μF	6.3V	C606	0248728	ceramic, discal 150pF K
C604	0252125	electrolytic	47μF	25V	C607	0248724	ceramic, discal 100pF K
C605	0248726	ceramic, discal	120pF	K	FOR TONE CONTROL CIRCUIT BOARD		
C606	0248728	ceramic, discal	150pF	K	R501	0112672	carbon, film 470kΩ K NLRD¼P
C607	0248724	ceramic, discal	100pF	K	R502	0112672	carbon, film 470kΩ K NLRD¼P
FOR TONE CONTROL CIRCUIT BOARD							
R501	0112672	carbon, film	470kΩ	K	R503	0112672	carbon, film 470kΩ K NLRD¼P
R502	0112672	carbon, film	470kΩ	K	R504	0112672	carbon, film 470kΩ K NLRD¼P
R503	0112672	carbon, film	470kΩ	K	R505	1114470	carbon, film 5.6kΩ K SRD¼P
R504	0112672	carbon, film	470kΩ	K	R506	1114470	carbon, film 5.6kΩ K SRD¼P
R505	1114470	carbon, film	5.6kΩ	K			
R506	1114470	carbon, film	5.6kΩ	K			