

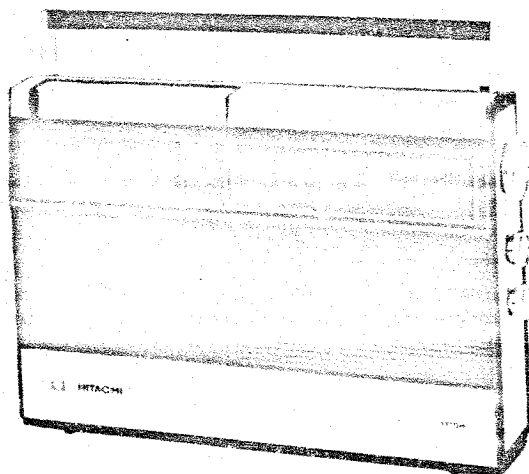

HITACHI
Hitachi, Ltd. Tokyo Japan



**FM/AM IC + TRANSISTOR PORTABLE
RADIO WITH CASSETTE TAPE RECORDER**

MODEL KCT-1210H

SERVICE MANUAL

No. 374

1971

SPECIFICATIONS

RADIO CIRCUIT SYSTEM..... Superheterodyne
TUNING RANGE..... FM: 88—108MHz
AM: 530—1,605KHz
INTERMEDIATE FREQUENCY... FM: 10.7MHz
AM: 460KHz

RADIO TUNER BLOCK

TRANSISTORS

TR1 2SC535/B..... FM RF Amp.
TR2 2SC535/B..... FM Conv.
TR3 2SC460/B..... AM Conv.
TR11 2SC460/B..... FM 1st IF Amp.
TR4 2SC460/B..... FM 2nd & AM 1st IF Amp.
TR5 2SC460/B..... FM 3rd & AM 2nd IF Amp.

DIODES

D1 1N60..... FM Limit.
D2 1S85..... AFC
D3 1N60..... FM Limit.
D4 1N34..... AGC
D5, D6 1N60/P..... FM Disc.
D7 1N34A..... AM Det. & AGC
VAR1 1R2..... Voltage Stabilizer

TAPE RECORDER & AMP. BLOCK

IC FA6005T..... AF Amp. & Driver
TR6 2SB73/B..... 1st PRE. Amp.
TR7 2SC458/C..... 2nd PRE. Amp.
TR8, TR9 2SB156/C/P × 2..... Power Amp.
TR10 2SB77/C..... Bias Osc.

DIODES

D9 1N34A..... Automatic level control
D10 1N34A..... Rectifier for level meter
D11 1N34A..... Rectifier for automatic level control
D13, D14 VO-6A × 2..... Rectifier

THERMISTOR

TH1 D-1E..... Temperature compensator

TAPE

TAPE..... Compact cassette
TAPE SPEED..... 1 7/8 ips (4.75cm/s)
RECORDING OR PLAYING TIME... 60min. using C-60
RECORDING SYSTEM..... AC bias (with LEVELMATIC)
ERASING SYSTEM..... DC erase
TRACK SYSTEM..... Monaural dual track
MOTOR..... Micromotor with governor
SPEAKER..... 3" × 5" (8 × 12cm) P.M., 8Ω
AUDIO OUTPUT..... 1000mW
FREQUENCY RANGE..... 100 ~ 9,000Hz
POWER SUPPLY..... DC: 6V (JIS "UM-1" × 4,
standard "D" or equivalent)
AC: 120V 60Hz

INPUT IMPEDANCE

MIC JACK..... 5K ohms
AUX. IN JACK..... 60K ohms

OUTPUT IMPEDANCE

OUTPUT JACK..... 8 ohms

MICROPHONE

..... Dynamic microphone (with remote-control switch)

ANTENNAS

FM: Telescopic antenna

SENSITIVITY

AM: Built in ferrite antenna
FM: 10dB (max) 18dB (practical) AM: 38dB (max) 50dB (practical)

TERMINALS

• MICROPHONE JACK
• REMOTE CONTROL JACK
• AUX. IN JACK
• OUTPUT JACK

DIMENSIONS

8 1/2"(H) × 12 1/2"(W) × 3 3/4"(D)

WEIGHT

7 lbs (3.2kg)

MODEL KCT-1210H SERVICE MANUAL

CONTROLS

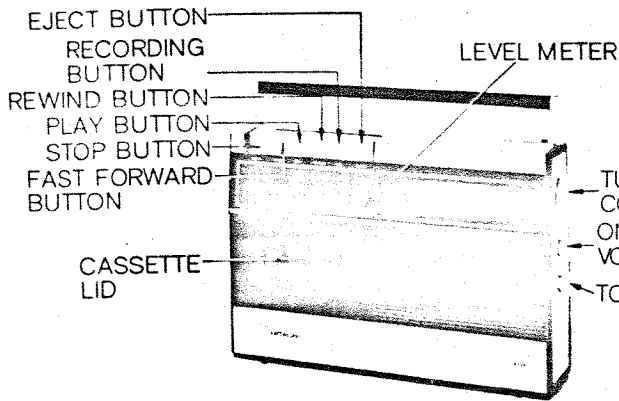

Fig. 1

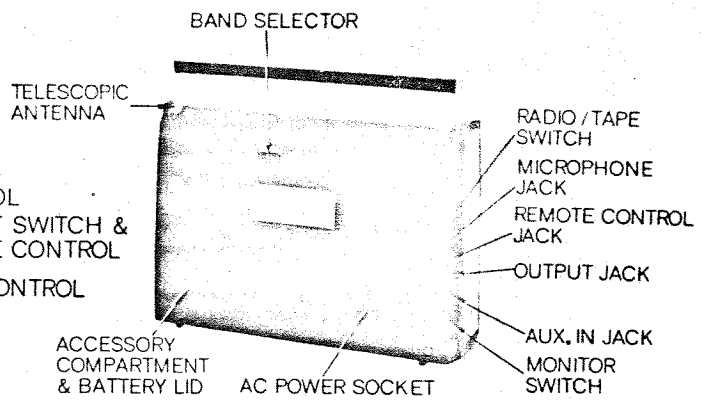
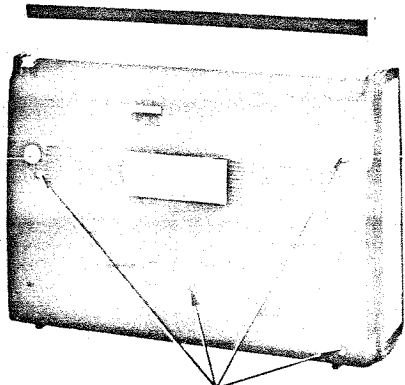

Fig. 2

DISASSEMBLY

1. Removal of back cover

Remove four screws holding rear case as shown in Fig. 3. Be careful not to cut telescopic antenna wire accidentally.



BACK COVER HOLDING SCREWS

Fig. 3

2. Removal of chassis

Remove knobs. Remove eight screws holding chassis as shown in Figs. 4 and 5.

CHASSIS HOLDING SCREWS

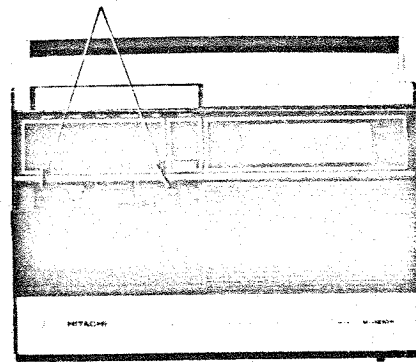

Fig. 4

3. Removal of circuit board

Remove seven screws holding circuit board and two screws holding jack board as shown in Fig. 6. Be careful not to cut wires accidentally.

CIRCUIT BOARD HOLDING SCREWS

JACK BOARD HOLDING SCREWS

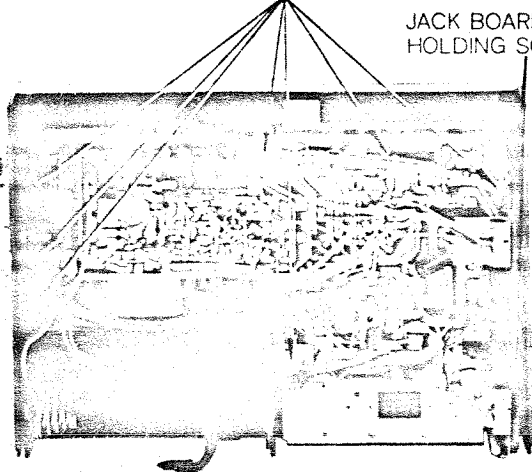

Fig. 6

CHASSIS HOLDING SCREWS

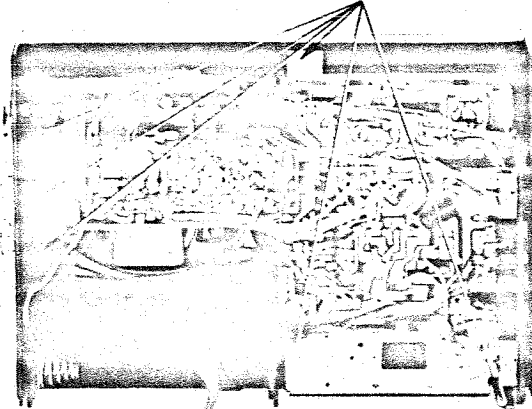

Fig. 5

BLOCK DIAGRAM

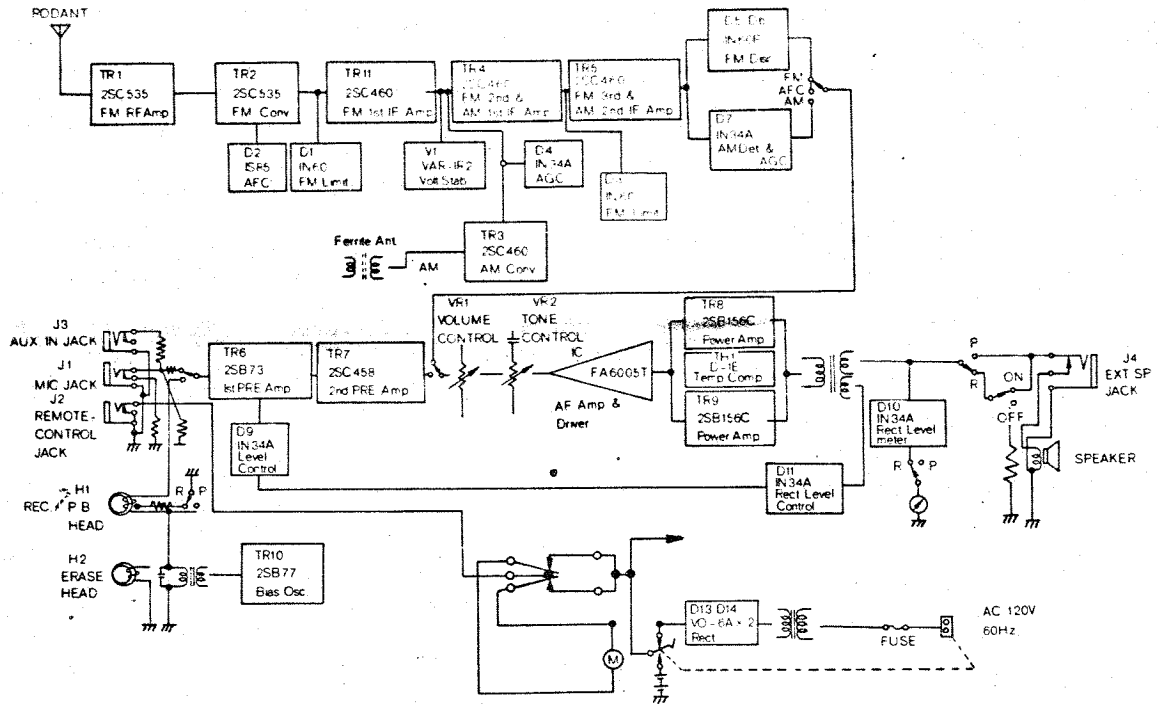

Fig. 7

DIAL CORD RESTRINGING

Referring to Fig. 8, loop the dial cord in the direction of arrows.

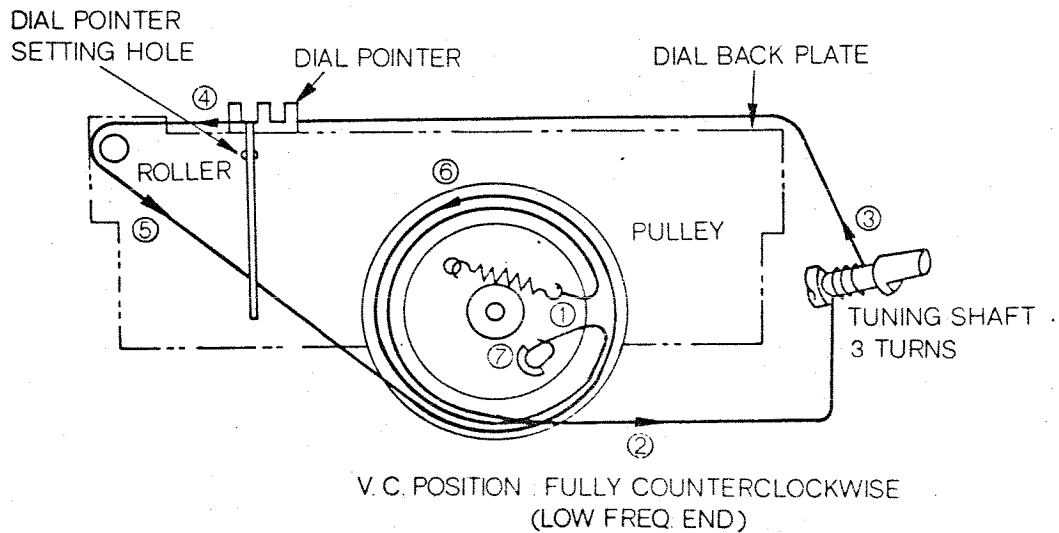

Fig. 8

MODEL KCT-1210H SERVICE MANUAL

ALIGNMENT PROCEDURE

Instrument Required

1. RF. Signal Generator
2. IF. Sweep Generator (Centered at 455KHz for AM and 10.7 MHz for FM)
3. Marker Generator
4. VTVM (Vacuum-tube Voltmeter)
5. Oscilloscope

General Preparation

1. Insert power cord plug into an AC outlet and receptacle into AC power socket of the set (AC 120V 60Hz)...check power supply voltage.
2. Turn the volume control knob to maximum. (In case of FM-IF and FM-DISC., turn the knob to minimum.)

3. During AM alignment, connect output of signal generator (modulated by 400Hz or 1,000Hz 30%) to a loop antenna (4 inches in diameter, 2 or 3 turns) and couple the loop antenna to the ferrite-core antenna. Connect the V.T.V.M. (AC 3V or less scale) to the speaker terminals.
During FM-RF alignment, connect output of signal generator to FM antenna terminal using a dummy antenna as shown in Fig. 11.
4. Adjust with an insulated screw driver to prevent bodyeffect.

FM IF ALIGNMENT

STEP	METER AND CONNECTION	DIAL POINTER SETTING	SIG. GEN. FREQ.	ADJUST FOR MAX. OUTPUT
①	OSCILLOSCOPE.....Connect VERT. terminal of oscilloscope to TP4. SWEEP GENERATOR..... Connect to TP3. Be sure to cut off direct current by putting suitable capacitor between sweep generator and TP3. Then, adjust as follows until the waveform as shown in Fig. 9 is obtained.	High freq. end	10.7MHz± 1MHz Sweep	Remove T5 core and adjust T4, T3, T2 and T1.
②	Repeat step ①			

FM DISC ALIGNMENT

STEP	METER AND CONNECTION	DIAL POINTER SETTING	SIG. GEN. FREQ.	ADJUST FOR MAX. OUTPUT
①	Same as FM-IF Then, adjust as follows until the waveform as shown in Fig. 10 is obtained.	High freq. end	10.7MHz± 1MHz Sweep	T5 core for waveform centered at 10.7MHz marker. Adjust T5 core until waveform maximum and minimum points are at the same distance from horizontal line as shown in Fig. 10.
②	Repeat step ①			

FM RF ALIGNMENT

STEP	METER AND CONNECTION	DIAL POINTER SETTING	SIG. GEN. FREQ.	ADJUST FOR MAX. OUTPUT	
①	SIGNAL GENERATOR..... Connect output terminal of FM signal generator to FM antenna terminal. VTVM..... Connect AC probe of VTVM to speaker terminals. Adjust as follows to gain maximum on VTVM.	Low freq. end	87MHz	L5	
②		High freq. end	109MHz	CT2	
③		Repeat steps ① and ②			
④		90MHz signal	90MHz	L4	
⑤		106MHz signal	106MHz	CT1	
⑥		Repeat steps ④ and ⑤			

AM IF ALIGNMENT

STEP	METER AND CONNECTION	DIAL POINTER SETTING	SIG. GEN. FREQ.	ADJUST FOR MAX. OUTPUT
①	SIGNAL GENERATOR..... Connect output terminal of AM signal generator to set through loop antenna. Adjust to gain maximum on VTVM.	High freq. end	455KHz	Remove T8 core and T7 and T6.
②		Repeat step ①		

AM RF ALIGNMENT

STEP	METER AND CONNECTION	DIAL POINTER SETTING	SIG. GEN. FREQ.	ADJUST FOR MAX. OUTPUT	
①	Same as AM-IF. Adjust as follows to gain maximum on VTVM.	Low freq. end	515KHz	L6	
②		High freq. end	1650KHz	CT4	
③		Repeat steps ① and ②.			
④		600KHz signal	600KHz	L10	
⑤		1400KHz signal	1400KHz	CT3	
⑥		Repeat step ④ and ⑤			

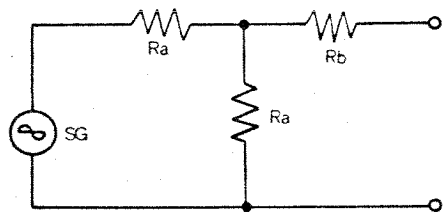
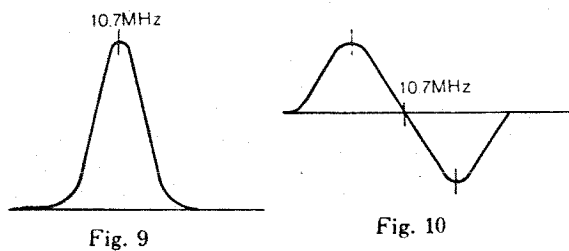

Ra.....Signal generator's output impedance
 Rb.....(75 - $\frac{R_a^2}{Z}$) ohms

Fig. 11

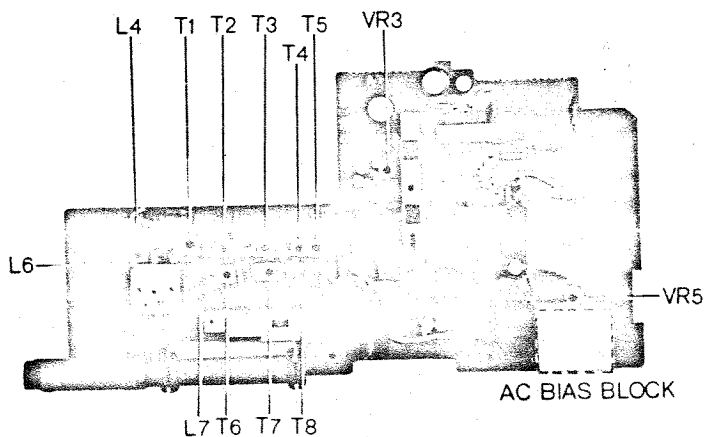

Fig. 12

MODEL KCT-1210H SERVICE MANUAL

REPLACEMENT PARTS

Symbol No.	Stock No.	Description		Symbol No.	Stock No.	Description	
CAPACITORS:							
C 1	0248645	Ceramic, discal	5PF ± 0.5PF	C 82	0275114	Mylar	0.033 μ F
C 4	0248708	Ceramic, discal	22PF ± 10%	C 83	0252231	Same as C63	
C 5	0248708	Same as C4		C 84	0252231	Same as C63	
C 6	0244016	Ceramic, discal	0.001 μ F	C 85	0259670	Same as C40	
C 7	0248645	Same as C1		C 86	0256003	Electrolytic	1000 μ F
C 8	0248669	Ceramic, discal	14PF ± 5%	C 87	0276111	Same as C58	10V
C 9	0248716	Ceramic, discal	47PF ± 10%	C 88	0275115	Same as C25	
C 10	0249513	Ceramic, discal	330PF ± 10%	C 91	0275111	Same as C21	
C 11	0248648	Ceramic, discal	8PF ± 0.5PF	C 93	0245017	Same as C14	
C 12	0244016	Same as C6		C 95	0221328	Styrol	510PF ± 5%
C 13	0246474	Ceramic, discal	15PF ± 10%	C 94	0275114	Same as C82	
C 14	0245017	Ceramic, discal	0.01 μ F	C 90	0275115	Same as C25	
C 15	0248646	Ceramic, discal	6PF ± 0.5PF	C 96	0275113	Same as C31	
C 16	0241854	Ceramic, discal	7PF ± 0.25PF	C 98	0274111	Same as C61	
C 21	0275111	Mylar	0.01 μ F	C 89	0252233	Electrolytic	330 μ F
C 23	0275111	Same as C21		CT1-CT4	0282561	Plastic film variable	6.3V
C 24	0221339	Styrol	1500PF ± 5%	CV1- CV4			
C 25	0275115	Mylar	0.047 μ F	RESISTORS			
C 26	0245017	Same as C14		R 1	0114449	Carbon film	470 Ω ± 10%
C 27	0275111	Same as C21		R 2	0137861	Carbon film	6.8K Ω
C 28	0248644	Ceramic, discal	4PF ± 0.5PF	R 3	0137806	Carbon film	270 Ω
C 29	0248646	Same as C15		R 4	0137851	Carbon film	1.0K Ω
C 30	0245017	Same as C14		R 5	0114471	Carbon film	6.8K Ω ± 10%
C 31	0275113	Mylar	0.022 μ F	R 6	0137857	Carbon film	3.3K Ω
C 32	0248724	Ceramic, discal	100PF ± 10%	R 7	0137855	Carbon film	2.2K Ω
C 33	0248642	Ceramic, discal	2PF ± 0.5PF	R 8	0114380	Carbon film	56 Ω
C 34	0248642	Same as C33		R 9	0137861	Same as R2	
C 35	0245017	Same as C14		R 10	0114441	Carbon film	100 Ω ± 10%
C 36	0275113	Same as C31		R 12	0137861	Same as R2	
C 37	0248724	Same as C32		R 13	0137857	Same as R6	
C 38	0252613	Electrolytic	3.3 μ F	R 14	0114465	Carbon film	2.2K Ω
C 39	0245017	Same as C14		R 15	0114450	Carbon film	560 Ω ± 10%
C 40	0259670	Electrolytic	1000 μ F	R 16	0137807	Carbon film	330 Ω
C 41	0274115	Mylar	0.0047 μ F	R 18	0137805	Carbon film	220 Ω
C 42	0275111	Same as C21		R 19	0137910	Carbon film	56K Ω
C 43	0275111	Same as C21		R 20	0137809	Carbon film	470 Ω
C 46	0252815	Electrolytic	4.7 μ F	R 21	0137803	Carbon film	150 Ω
C 47	0275111	Same as C21		R 22	0137861	Same as R2	
C 48	0245017	Same as C14		R 23	0114449	Same as R1	
C 49	0245017	Same as C14		R 24	0137851	Same as R4	
C 53	0245018	Ceramic, discal	0.02 μ F	R 25	0137801	Carbon film	100 Ω
C 54	0245018	Same as C53		R 26	0137807	Same as R16	
C 55	0274114	Mylar	0.0033 μ F	R 27	0137903	Carbon film	15K Ω
C 56	0252613	Same as C38		R 28	0114447	Carbon film	330 Ω ± 10%
C 57	0252613	Same as C38		R 29	0137763	Carbon film	22 Ω ± 10%
C 58	0276111	Mylar	0.1 μ F	R 34	0114461	Carbon film	1K Ω ± 10%
C 59	0275116	Mylar	0.068 μ F	R 35	0137956	Carbon film	270K Ω ± 10%
C 60	0276112	Mylar	0.15 μ F	R 36	0137860	Carbon film	5.6K Ω
C 61	0274111	Mylar	0.001 μ F	R 37	0137809	Same as R20	
C 62	0252223	Electrolytic	33 μ F	R 46	0114530	Carbon film	56K Ω ± 10%
C 63	0252231	Electrolytic	100 μ F	R 47	0114447	Same as R28	
C 64	0252613	Same as C38		R 48	0114470	Carbon film	5.6K Ω ± 10%
C 65	0252231	Same as C63		R 49	0114449	Same as R1	
C 66	0252811	Electrolytic	1 μ F	R 50	0137904	Carbon film	18K Ω
C 67	0252811	Same as C66		R 51	0137909	Carbon film	47K Ω
C 68	0252231	Same as C63		R 52	0137801	Same as R25	
C 70	0275115	Same as C25		R 53	0137862	Carbon film	8.2K Ω
C 72	0252815	Same as C46		R 54	0137901	Carbon film	10K Ω
C 73	0252231	Same as C63		R 55	0137859	Carbon film	4.7K Ω
C 74	0274113	Mylar	0.002 μ F	R 56	0137861	Same as R2	
C 75	0274113	Same as C74		R 57	0137905	Carbon film	22K Ω
C 76	0275111	Same as C21		R 58	0137855	Same as R7	
C 77	0274116	Mylar	0.0068 μ F	R 59	0137812	Carbon film	820 Ω
C 78	0252621	Electrolytic	10 μ F	R 60	0137859	Same as R55	
C 79	0252811	Same as C66		R 61	0137905	Same as R57	
C 80	0274115	Same as C41		R 62	0137911	Carbon film	68K Ω
C 81	0274111	Same as C61		R 63	0137959	Carbon film	470K Ω ± 10%

SCHEMATIC DIAGRAM

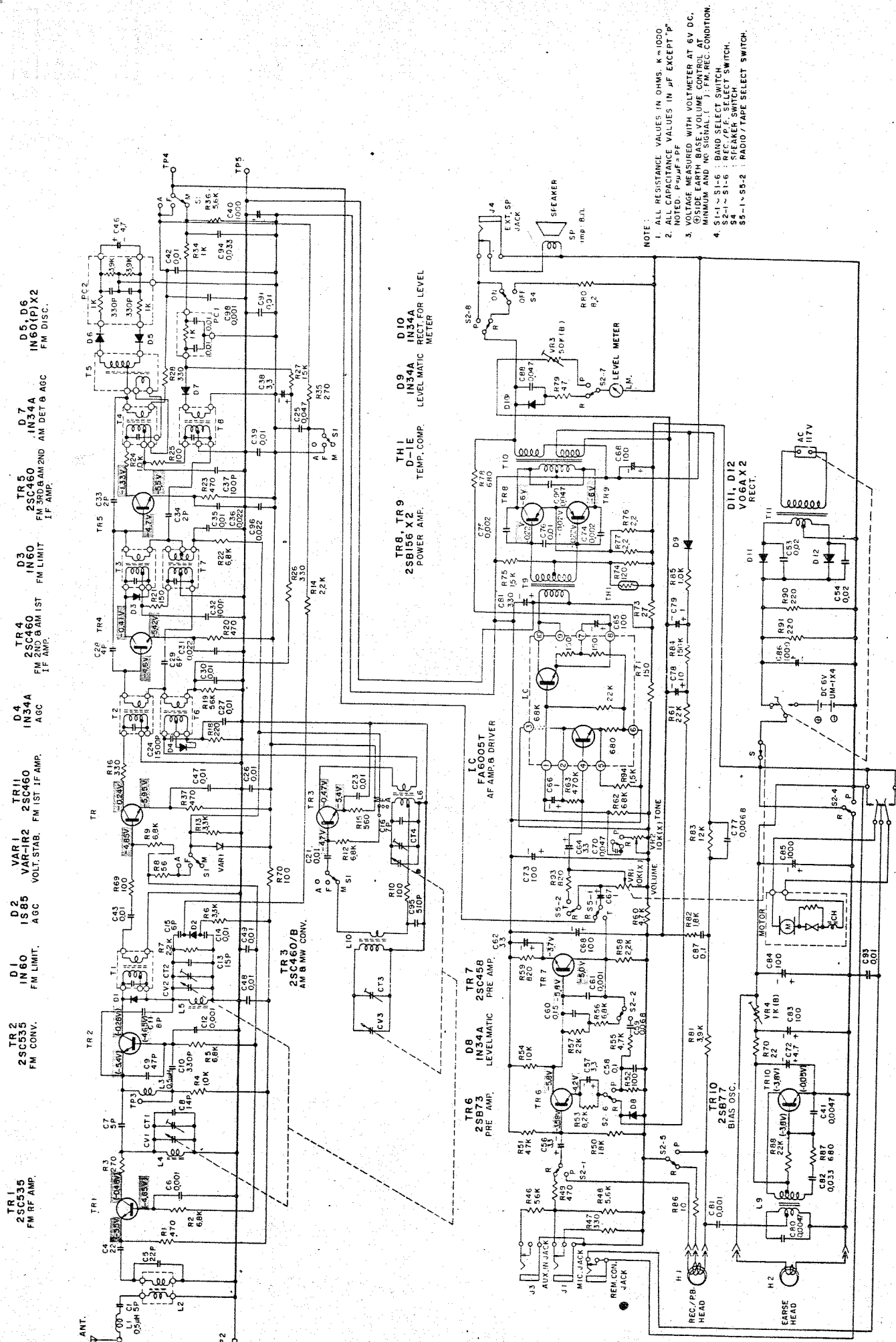

- TR1 2SC335 FM RF AMP.
- TR2 2SC535 FM CONV.
- D1 IN60 FM LIMIT.
- D2 IS85 VOLT. STAB. AGC
- TR3 2SC460/B AM B MW CONV.
- TR4 2SC460 FM 2ND & AM 1ST IF AMP.
- D3 IN344 AGC
- TR5 2SC460 FM 3RD & AM 2ND IF AMP.
- D4 IN344 FM DET & AGC
- D5, D6 IN60(P) X2 FM DISC.
- D7 IN344
- TR8, TR9 2SB156 X2 POWER AMP.
- TR10 2SB77 BIAS OSC.
- TR11 IN344 FM 1ST IF AMP.
- D8 IN344 LEVELMATIC PRE AMP.
- D9 IN344 LEVELMATIC RECT. FOR LEVEL METER
- D10 IN344 LEVELMATIC RECT. FOR LEVEL METER
- D11, D12 V06A X2

NOTE:

- ALL RESISTANCE VALUES IN OHMS, K=1000
- ALL CAPACITANCE VALUES IN μ F EXCEPT "P" NOTED. P= μ F=PF
- VOLTAGE MEASURED WITH VOLTMETER AT 6V DC. (SIDE EARTH BASE, VOLUME CONTROL AT MINIMUM AND NO SIGNAL.) : FM REC. CONDITION.
- S1-1 ~ S1-6 : BAND SELECT SWITCH
S2-1 ~ S2-6 : SPEAKER SWITCH
S3-1 ~ S3-2 : RADIO / TAPE SELECT SWITCH.



CIRCUIT BOARD DIAGRAM

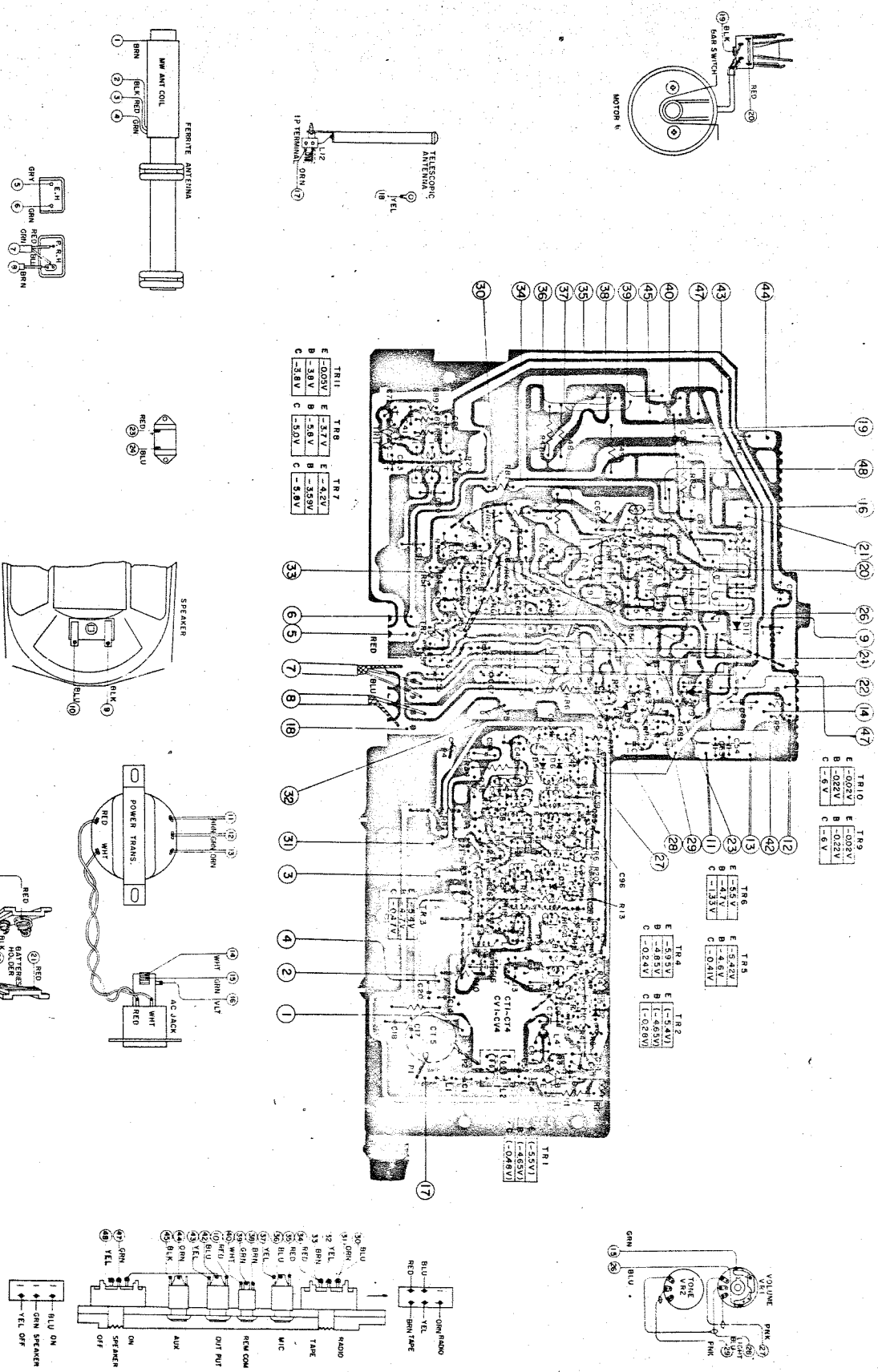

MECHANICAL DIAGRAM

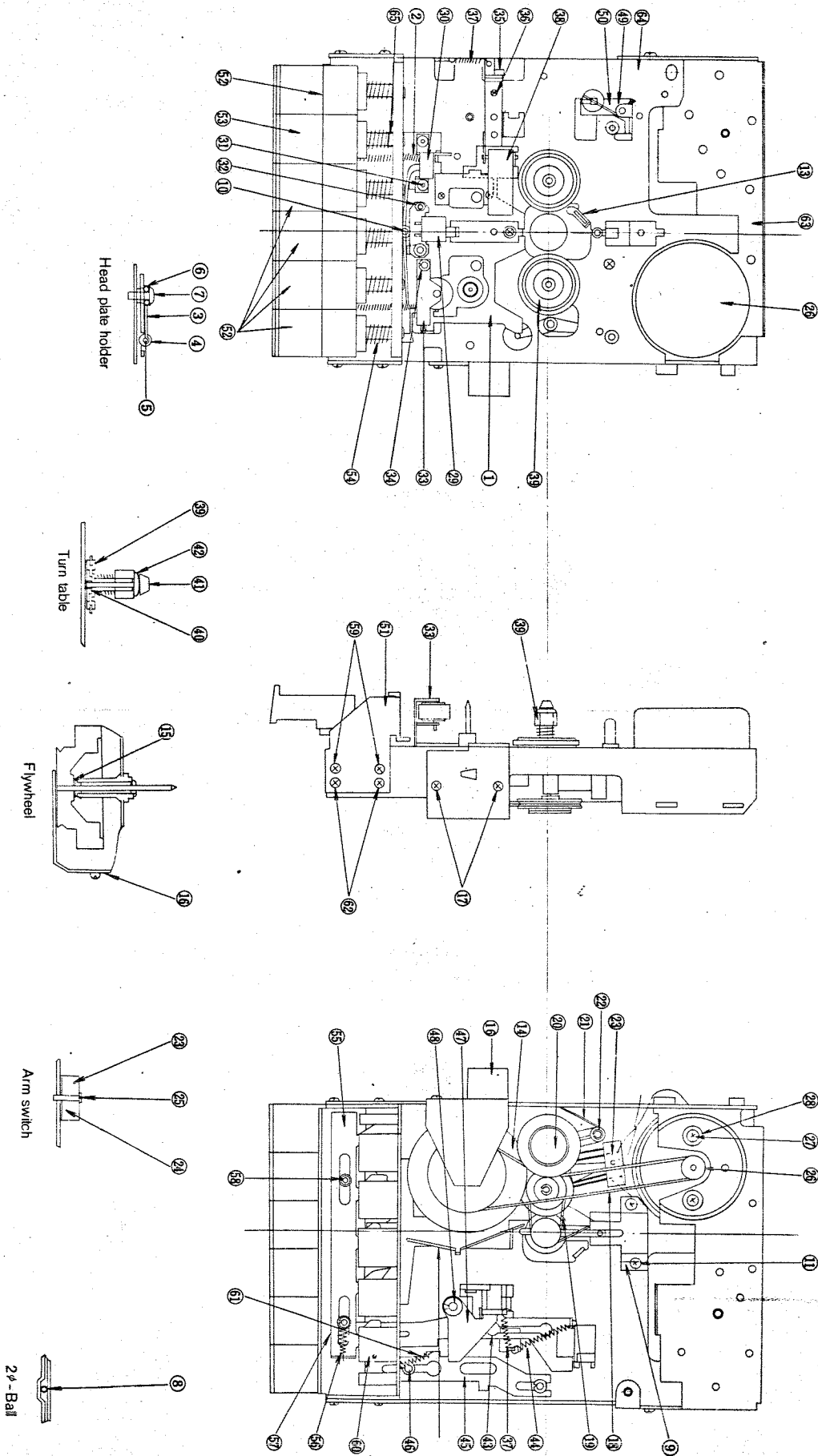

MODEL KCT-1210H SERVICE MANUAL

Symbol No.	Stock No.	Description			Symbol No.	Stock No.	Description
R 69	0137801	Same as R25			TRANSFORMERS:		
R 70	0137801	Same as R25			TH 1	0576056	Thermistor D-IE
R 71	0137803	Same as R21			VAR 1	0170301	Varistor 1R2
R 73	0114376	Carbon film	27Ω ± 10%	1/4SD	T 1	0322324	FM IF
R 74	0137802	Carbon film	120Ω	1/4SD	T 2	0322339	FM IF
R 75	0137853	Carbon film	1.5KΩ	1/4SD	T 3	0322340	FM IF
R 76	0114361	Carbon film	2.2Ω ± 10%	1/4P	T 4	5118011	Discriminator
R 77	0114361	Same as R76			T 5	0326024	Discriminator
R 78	0137811	Carbon film	680Ω	1/4SD	T 6	0322144	AM IF
R 79	0137767	Carbon film	47Ω	1/4SD	T 7	5136012	AM IF
R 80	0134288	Composition	8.2Ω ± 10%	1/2GF	T 8	0322130	AM IF
R 81	0137858	Carbon film	3.9KΩ	1/4SD	T 9	0441084	Driver
R 82	0114464	Carbon film	1.8KΩ ± 10%	1/4P	T10	0451103	Output
R 83	0137902	Carbon film	12KΩ	1/4SD	COILS:		
R 84	0137953	Carbon film	150K	1/4SD	L 1	0324003	FM Choke 0.5μF
R 85	0137851	Same as R4			L 2	0318519	FM Antenna
R 86	0114371	Carbon film	10Ω ± 10%	1/4P	L 3	0324003	Same as L1
R 87	0137811	Same as R78			L 4	5126006	FM RF
R 88	0137905	Same as R57			L 5	5126007	FM Oscillator
R 89	0137759	Carbon film	10Ω	1/4SD	L 6	5120244	MW Oscillator
R 90	0134365	Composition	220Ω ± 10%	1/2GF	L 9	5128012	AC Oscillator 33KHz
R 91	0134365	Same as R90			for Final assembly		
R 93	0137812	Same as R59			0013012	Tuning control knob	
R 94	0137853	Same as R75			0015846	Knob-20φ	
VR 1	0151727	Volume with switch	10KΩ (X)		6310162	Spring washer	
VR 2	0151367	Volume	10K (X)		6714341	Shaft spacer	
VR 3	0151821	Semi variable resistor	50KΩ (B)		7712605	Spacer	
VR 5	0151806	Semi variable resistor	1KΩ (B)		7503668	Column	
PC 1	0186001	CR Pack			8745408	Binding screw-3mmφ·8mm(6 req'd)	
PC 2	0186352	CR Pack			8781440	for rear case, tape recorder chassis mounting Tapping screw-3mmφ·10mm (3 req'd) for chassis, case mounting	
TRANSISTORS:					for Radio Chassis assembly		
TR 1	0573510		2SC535	Si 100MHZ 200mW	5740621	Power cord	
TR 2	0573510	Same as TR1			0592052	Earphone	
TR 3	0573486		2SC460	Si 100MHZ 200mW	6122201	Front case assembly Front case assembly	
TR 4	0573486	Same as TR3			0526167	Speaker-8·12	
TR 5	0573486	Same as TR3			0681113	Speaker support	
TR 6	0573018		2SB73	Ge 10KHZ 20mW	8781436	Tapping screw-3mmφ·6mm (2 req'd) for speaker mounting	
TR 7	5320023		2SC458	Si 10KHZ 200mW	6703401	Battery bracket assembly	
TR 8	0573012		2SB156	Ge 10KHZ 150mW	6703402	Battery bracket assembly	
TR 9	0573049	Same as TR8			6122221	Rear case assembly Rear case assembly	
TR 10	0573037	Same as TR8			5750151	Rod antenna	
TR 11	0573486	Same as TR3			7204161	Antenna bracket	
IC 1	5350071	Hybrid IC	FA-6005		8711406	Pan head screw-3mmφ·6mm for rod antenna mounting	
D1	0575005	Diode	1N60	Ge 10.7MHZ Si 10MHZ	8781436	Tapping screw-3mmφ·6mm for rod antenna mounting	
D2	0575024	Diode	1S85		0544408	Lug terminal	
D3	0575005	Same as D1			6166041	Battery cover assembly	
D4	0575001	Diode	1N34A	Ge 455KHZ Ge 10.7MHZ	7587672	Column	
D5	0575019	Diode	1N60(P)		8821114	Nut-3mmφ	
D6	0575019	Same as D5			8711405	Pan head screw-3mmφ·5mm(3 req'd) for tape recorder chassis, P.C.B mounting	
D7	0575001	Same as D4					
D9	0575001	Same as D4					
D10	0575001	Same as D4					
D11	0575001	Same as D4					
D13	5330104	Diode	VO-6A	Si 60HZ			
D14	5330104	Same as D13					

MODEL KCT-1210H SERVICE MANUAL

Symbol No.	Stock No.	Description	Symbol No.	Stock No.	Description
	8781436	Tapping screw-3mm ϕ x 6mm for P.C.B chassis mounting		8781436	Tapping screw-3mm ϕ x 6mm (2 req'd) for antenna supporter mounting
	7205401	Level indicator holder		5590522	Cassette assembly for Tape recorder Chassis assembly
	8781335	Tapping screw-2.6mm ϕ x 5mm		① 7211681	Head plate assembly
	5550034	Level indicator		② 0630122	Rewind spring
	7204381	Jack holder U		③ 6310511	Head plate holder
	7204391	Jack holder S		④ 0015595	Roller-5 ϕ
	7771854	Screw with spring washer-2.6mm ϕ x 6mm (2 req'd) for jack holder U mounting		⑤ 0942042	Roller shaft
	8781336	Tapping screw-2.6mm ϕ x 6mm (2 req'd) for jack holder S mounting		⑥ 7501351	Head plate collar
	7207351	R holder		⑦ 0711308	Pan head screw-2.6mm ϕ x 8mm
	5670541	Jack assembly		8811113	Washer-2.6mm ϕ
	8721406	Flat screw-3mm ϕ x 6mm (2 req'd) for jack plate mounting		⑧ 0948492	Ball-2 ϕ
	7204641	AC plug holder		⑨ 7193872	Function plate guide
	5650092	2P socket		⑩ 7505342	Function collar
	7711671	Socket spacer		⑪ 0711305	Pan head screw-2.6mm ϕ x 5mm
	7771854	Screw with spring washer-2.6mm ϕ x 6mm (2 req'd) for 2P socket mounting.		7778394	"E" ring
	8781436	Tapping screw-3mm ϕ x 6mm (2 req'd) for AC plug holder mounting		7778395	"E" ring
	0411763	Power transformer		7512371	Function collar (B)
	8781436	Tapping screw-3mm ϕ x 6mm (2 req'd) for transformer mounting		⑫ 7193851	Function plate assembly
	7508586	Tuning shaft assembly		6706743	Fast forward arm assembly
	0711308	Pan head screw-2.6mm ϕ x 8mm (2 req'd) for bearing mounting		7778395	"E" ring
	0821233	Nut-2.6mm ϕ (2 req'd) for bearing mounting		6310745	Lever spring
	7204671	Band change-over assembly		⑬ 7663971	Roller stopper
	6266801	Lever knob		⑭ 6370395	Flywheel assembly
	0711305	Pan head screw-2.6mm ϕ x 5mm (2 req'd) for band change-over ass mounting		⑮ 0948832	Polyester washer
	7207342	Cord bracket		⑯ 7194162	Flywheel support assembly
	8711406	Pan head screw-3mm ϕ x 6mm (2 req'd) for cord bracket mounting		⑰ 0711305	Pan head screw-2.6mm ϕ x 5mm
	7207361	Holder for variable capacitor		⑱ 0971246	Belt-1.2 \square
	6703291	Pulley		⑲ 7660854	FR Belt
	8711406	Pan head screw-3mm ϕ x 6mm (2 req'd) for holder mounting		⑳ 6709471	Take up arm assembly
	0711305	Pan head screw-2.6mm ϕ x 5mm (3 req'd) for variable capacitor pulley mounting		㉑ 6313581	Take up arm spring
	6609451	Back plate		㉒ 7778395	"E" ring
	8711410	Pan head screw-3mm ϕ x 10mm }		㉓ 5630223	Arm switch
	8781436	Tapping screw-3mm ϕ x 6mm } for back plate mounting		㉔ 7730603	Switch mounting plate
	0662701	Spring		㉕ 8711110	Pan head screw-2mm ϕ x 10mm
	6391391	Pointer		㉖ 5570541	Micro motor
	7204181	Antenna supporter		㉗ 0711304	Pan head screw-2.6mm ϕ x 4mm
				㉘ 8811113	Washer-2.6mm ϕ
				㉙ 5440201	Record playback head
				⑳ 0513310	Erase head
				㉚ 8715104	Pan head screw-2mm ϕ x 4mm
				6310612	Head spring
				㉛ 8821231	Nut-2mm ϕ
				8812231	Washer-2mm ϕ
				7175161	Staple
				㉜ 7177321	Pressure roller arm assembly
				6310561	Pressure roller spring
				㉝ 7778395	"E" ring

MODEL KCT-1210H SERVICE MANUAL

Symbol No.	Stock No.	Description	Symbol No.	Stock No.	Description
35	7193921	Lock holder assembly	55	7208401	Lock plate
36	0711305	Pan head screw-2.6mm ϕ \times 5mm	56	6311051	Lock spring
37	0948442	Rewinding idler spring	57	0941258	"E" ring
38	6710583	Cassette up arm	58	0637119	Fiber washer
39	7662261	Turn table (A) assembly	59	7771854	Screw with spring washer-2.6mm ϕ \times 6mm (4 req'd) for button holder mounting
40	0662220	Back tension spring	60	7200761	Button support
41	0930002	Cap	61	6313703	Rewinding idler spring
42	0948831	Polyester washer	62	7771854	Screw with spring washer-2.6mm ϕ \times 6mm
43	7204621	Recording plate assembly	63	7204651	Motor holder
44	0662110	Fast forward cam spring	64	7771854	Screw with spring washer-2.6mm ϕ \times 6mm for motor holder mounting
45	7193831	Cassette up slider	65	7586891	Sleeve for Printed circuit board assembly
46	7778395	"E" ring	SI-1~	5620381	Slide switch
47	6710561	Cassette arm (B)	SI-8	5620721	Slide switch
48	0941258	"E" ring	SI-1~	5620712	Slide switch
49	7194371	Recording prevention arm	S2-10	7213241	Radiator plate
	7778395	"E" ring	S3-1~	7814891	Cushion (Right)
50	6313771	Recording prevention spring	S3-4	7814901	Cushion (Left)
51	7201381	Button holder assembly		7826621	Carton box
52	6266841	Button		7617754	Operating instructions
53	6266842	Button			
54	6313932	Button spring			

