

AM-FM AC/DC—Hitachi KH-1038

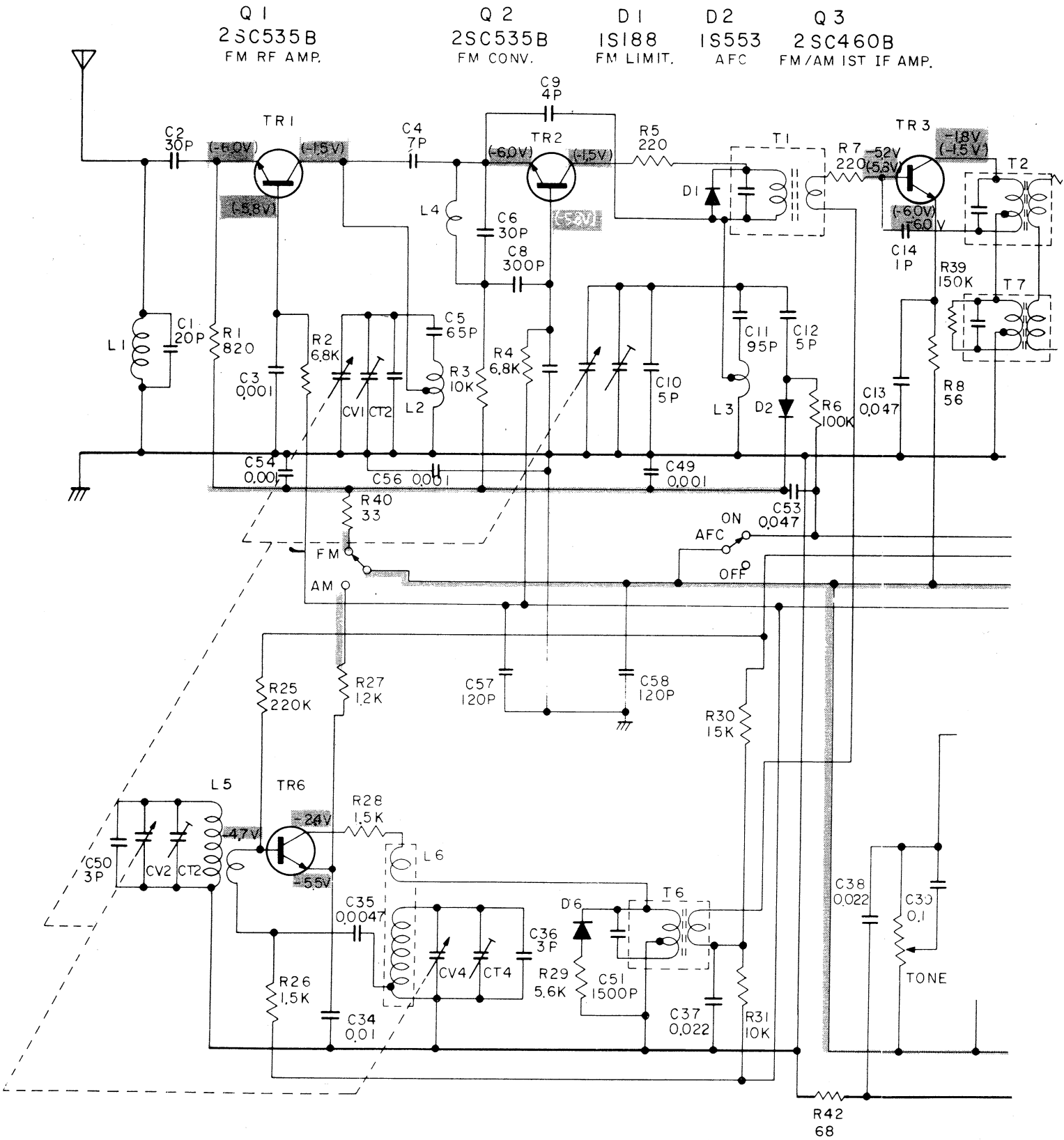

Q 4
2SC460B
FM/AM 2ND IF AMP

D 3
AM DET.

Q 5
2SC460C
FM 3RD IF AMP

D 4, D 5
FM DESCRI.

D 9
KB-265
VOLT. STAB.

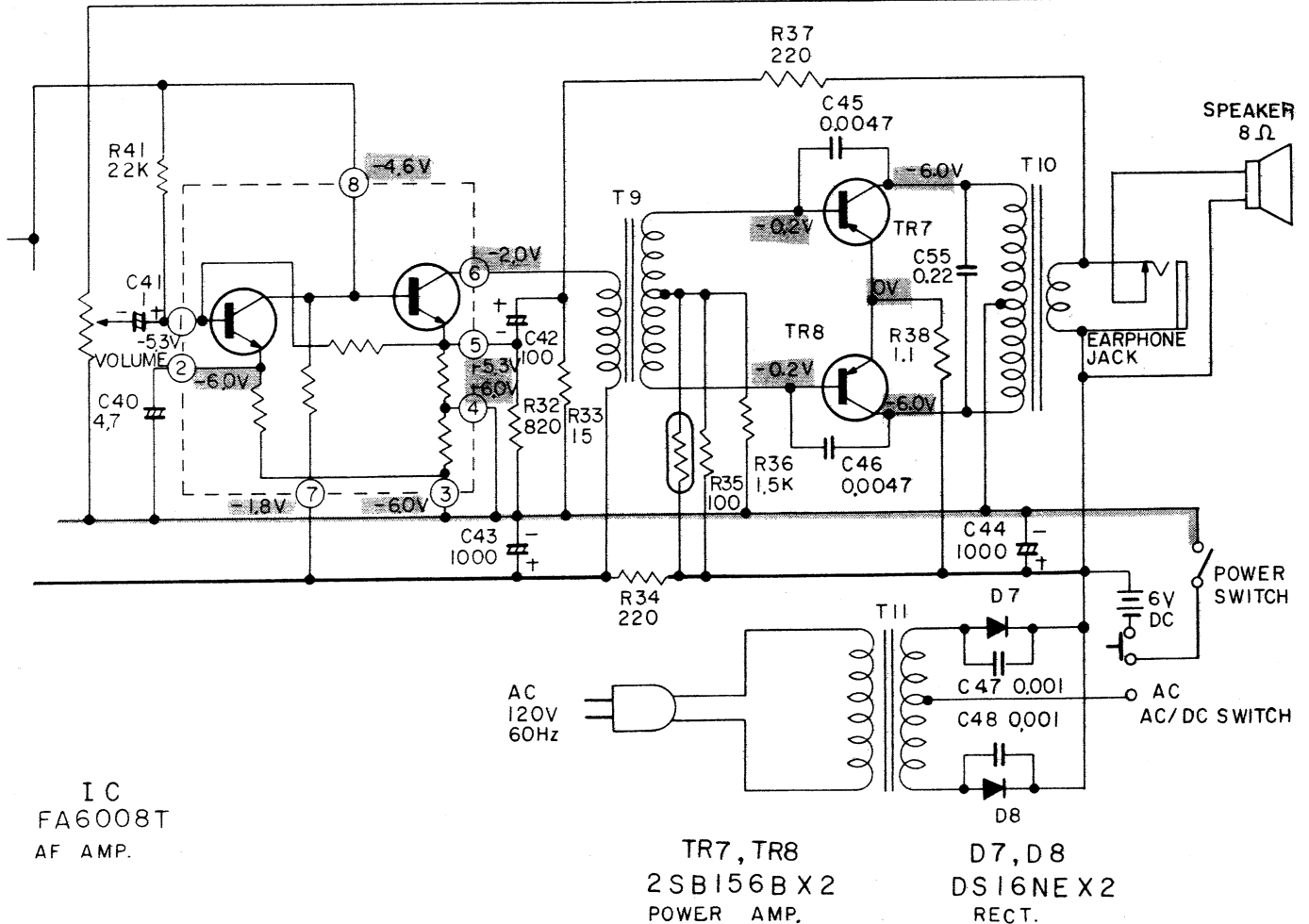
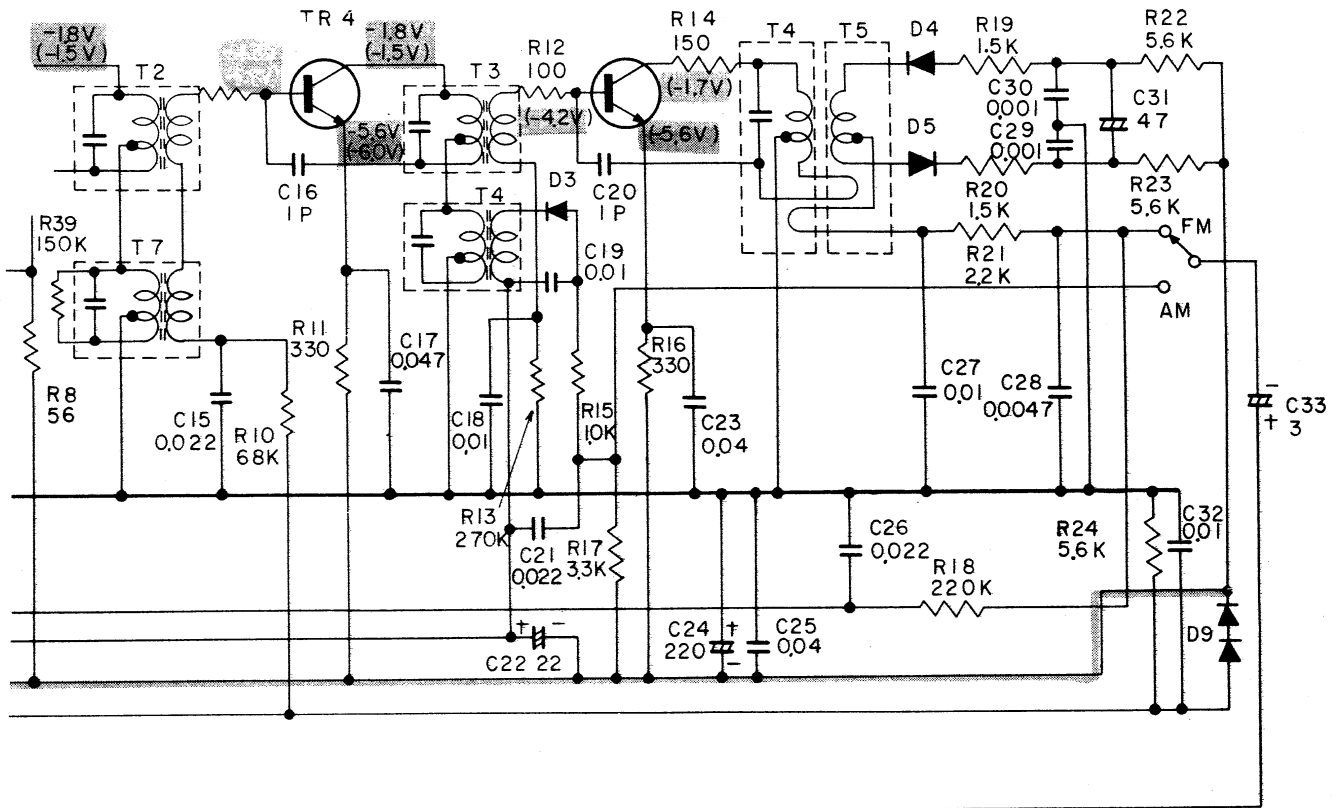

IC
FA6008T
AF AMP.

TR 7, TR 8
2SB156BX 2
POWER AMP.

D 7, D 8
DS16NEX 2
RECT.

REPLACEMENT PARTS

Symbol No.	Stock No.	Description		Symbol No.	Stock No.	Description	
CAPACITORS:							
C	1	0248667 Ceramic disc	20pF ± 5pF	R	15	0137851 Carbon film	1.0K Ω
C	2	0248671 Ceramic disc	30pF ± 5%	R	16	0137807 Carbon film	330 Ω
C	3	0244161 Ceramic disc	0.001 μF	R	17	0137857 Carbon film	3.3K Ω
C	4	0248647 Ceramic disc	7pF ± 0.5pF	R	18	0137955 Carbon film	220K Ω
C	5	0249527 Ceramic disc	65pF ± 5%	R	19	0137853 Carbon film	1.5K Ω
C	6	0248671 Ceramic disc	30pF ± 5%	R	20	0137853 Carbon film	220K Ω
C	7	0244161 Ceramic disc	0.001 μF	R	21	0137855 Carbon film	2.2K Ω
C	8	0248695 Ceramic disc	300pF ± 5%	R	23	0137860 Carbon film	5.6K Ω
C	9	0248644 Ceramic disc	4pF ± 0.5pF	R	24	0137860 Carbon film	5.6K Ω
C	10	0248645 Ceramic disc	5pF ± 0.5pF	R	25	0137955 Carbon film	220K Ω
C	11	0249528 Ceramic disc	95pF ± 5%	R	26	0137853 Carbon film	1.5K Ω
C	12	0248645 Ceramic disc	5pF ± 0.5pF	R	27	0137852 Carbon film	1.2K Ω
C	13	0275115 Mylar	0.047 μF ± 20%	R	28	0137853 Carbon film	1.5K Ω
C	14	0248641 Ceramic disc	1pF ± 0.5pF	R	29	0137860 Carbon film	5.6K Ω
C	15	0275113 Mylar	0.022 μF ± 20%	R	30	0137903 Carbon film	15K Ω
C	16	0248641 Ceramic disc	1pF ± 0.5pF	R	31	0137901 Carbon film	10K Ω
C	17	0275115 Mylar	0.047 μF ± 20%	R	32	0137812 Carbon film	820 Ω
C	18	0275111 Mylar	0.01 μF ± 20%	R	33	0137761 Carbon film	15 Ω
C	19	0275111 Mylar	0.01 μF ± 20%	R	34	0137805 Carbon film	220 Ω
C	20	0448641 Ceramic disc	1pF ± 0.5pF	R	35	0137801 Carbon film	100 Ω
C	21	0275113 Mylar	0.022 μF ± 20%	R	36	0137853 Carbon film	1.5K Ω
C	22	0252322 Electrolytic	22 μF	R	37	0137805 Carbon film	220 Ω
C	23	0275115 Mylar	0.047 μF ± 20%	R	38	0183801 Carbon film	1.1 Ω
C	24	0252332 Electrolytic	220 μF	R	39	0137953	150K Ω
C	25	0275115 Mylar	0.047 μF ± 20%	R	40	0137765	33 Ω
C	26	0275113 Mylar	0.022 μF ± 20%	R	41	0137905	22K Ω
C	27	0275111 Mylar	0.01 μF ± 20%	R	42	0137769	68 Ω
C	28	0274115 Mylar	0.0047 μF ± 20%				
C	29	0274111 Mylar	0.001 μF ± 20%				
C	30	0274111 Mylar	0.001 μF ± 20%				
C	31	0252615 Electrolytic	47 μF				
C	32	0275114 Mylar	0.01 μF ± 20%				
C	33	0252613 Electrolytic	3.3 μF				
C	34	0275111 Mylar	0.01 μF ± 20%				
C	35	0274115 Mylar	0.0047 μF ± 20%				
C	36	0248643 Ceramic disc	3pF ± 0.5pF				
C	37	0275113 Mylar	0.022 μF ± 20%				
C	38	0275113 Mylar	0.022 μF ± 20%				
C	39	0276111 Mylar	0.1 μF ± 20%				
C	40	0252615 Electrolytic	4.7 μF				
C	41	0252611 Electrolytic	1 μF				
C	42	0252331 Electrolytic	100 μF				
C	43	0256003 Electrolytic	1000 μF				
C	44	0256003 Electrolytic	1000 μF				
C	45	0274115 Mylar	0.0047 μF ± 20%				
C	46	0274115 Ceramic disc	0.0047 μF ± 20%				
C	47	0244161 Ceramic disc	0.001 μF				
C	48	0244161 Ceramic disc	0.001 μF				
C	49	0244161 Ceramic disc	0.001 μF				
C	50	0246423 Ceramic disc	3pF ± 0.5pF				
C	51	0221339 Styrol	1500pF ± 5%				
C	52	0246430 Ceramic disc	10pF ± 0.5pF				
C	53	0244175 Ceramic disc	0.047 μF				
C	54	0244161 Ceramic disc	0.01 μF				
C	55	0276013 Mylar	0.22 μF				
C	56	0274111 Mylar	0.001 μF				
C	57	0247896 Ceramic disc	120pF				
C	58	0247896 Ceramic disc	120pF				
RESISTORS:							
R	1	0137812 Carbon film	820 Ω				¼SD
R	2	0137861 Carbon film	6.8K Ω				¼SD
R	3	0137851 Carbon film	1.0K Ω				¼SD
R	4	0137861 Carbon film	6.8K Ω				¼SD
R	5	0137805 Carbon film	220 Ω				¼SD
R	6	0137951 Carbon film	100K Ω				¼SD
R	7	0137805 Carbon film	220 Ω				¼SD
R	8	0137768 Carbon film	56 Ω				¼SD
R	9	0137805 Carbon film	220 Ω				¼SD
R	10	0137861 Carbon film	6.8K Ω				¼SD
R	11	0137807 Carbon film	330 Ω				¼SD
R	12	0137801 Carbon film	100 Ω				¼SD
R	13	0137956 Carbon film	270K Ω				¼SD
R	14	0137803 Carbon film	150 Ω				¼SD
TRANSISTORS:							
TR	1	0573510				2SC535B	
TR	2	0573510				2SC535B	
TR	3	0573486				2SC460B	
TR	4	0573486				2SC460B	
TR	5	0573487				2SC460C	
TR	6	0573485				2SC460A	
TR	7	0573002				2SB156B	
TR	8	0673002				2SB156B	
IC	1	5353031				FA-6008T	
D	1	5330332				1S-188AM	
D	2	5340082				1S-553	
D	3	5330332				1S-188AM	
D	4	5330331				1S-188FM	
D	5	5330331				1S-188FM	
D	6	5330332				1S-188AM	
D	7	5330301				DS-16NE	
D	8	5330301				DS-16NE	
D	9	5340051	Varistor			KB-265	
TH	1	5340061	Thermister				
TRANSFORMERS:							
T	1	5130034	AM IF				
T	2	5130043	AM IF				
T	3	5130033	AM IF				
T	4	5140031	FM IF				
T	5	5140019	FM IF				
T	6	5148051	FM IF				
T	7	5148052	FM IF				
T	8	0324003	IF trap				
T	9	5230061	In put				
T	10	5250071	Out put				
T	11	5211023	Power				
COILS:							
L	1	5126233	FM Antenna				
L	2	5126234	FM RF				
L	3	5126235	FM osc				
L	4	5120275	AM osc				