

DISASSEMBLY

1. Removal of back cover

Remove three screws holding back cover shown in Fig. 3.

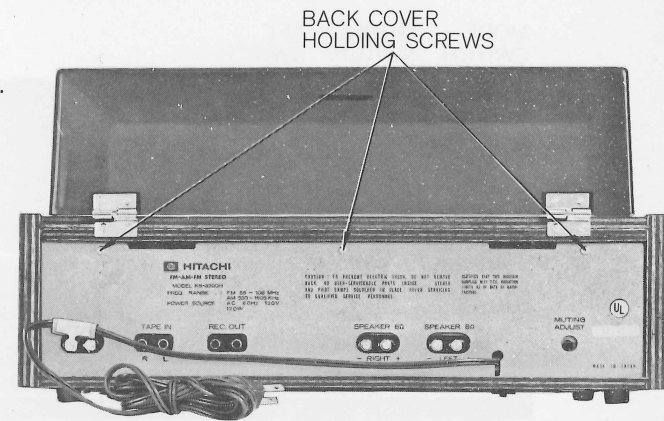

Fig. 3

2. Removal of chassis.

After pulling out the six knobs and a power switch knob, remove four screws holding chassis and take out the chassis shown in Fig. 4.

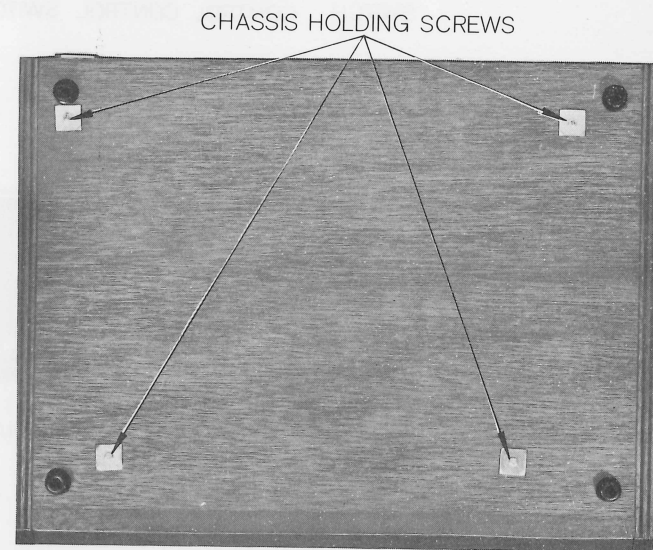

Fig. 4

3. Removal of front panel.

Remove five screws holding front panel shown in Figs. 5 and 6.

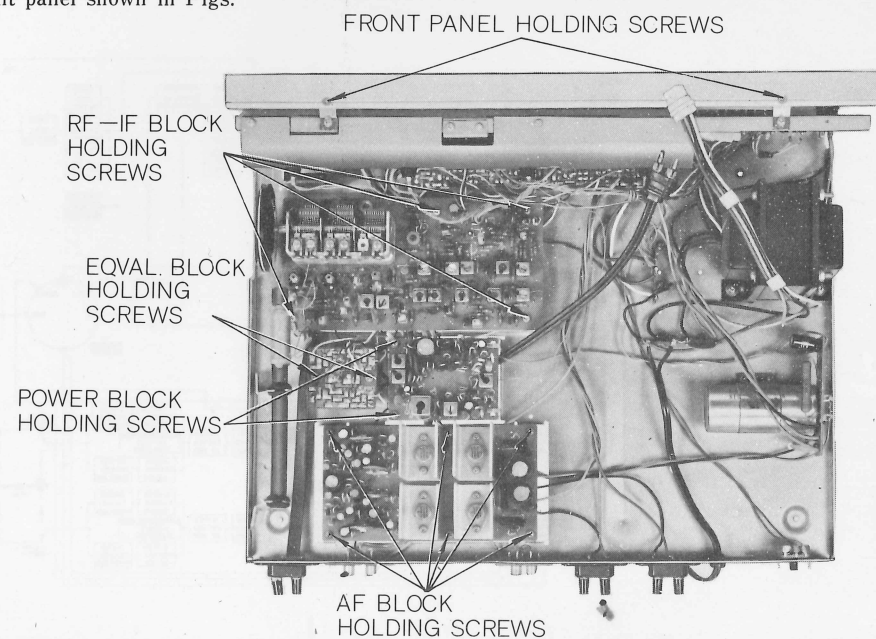

Fig. 5

4. Removal of dial lamp cover.

Remove two screws holding dial lamp cover shown in Fig. 7.

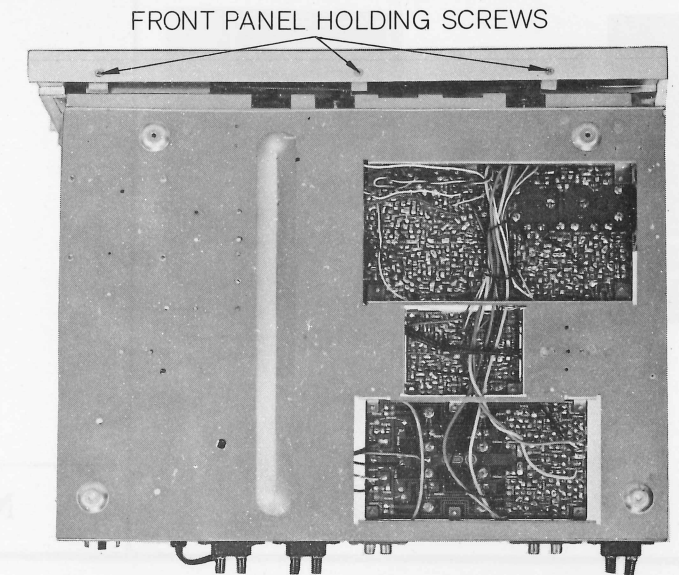

Fig. 6

5. Removal of indicator.

Remove two screws holding indicator shown in Fig. 7.

DIAL LAMP COVER HOLDING SCREWS (2)
INDICATOR HOLDING SCREWS
DIAL LAMP COVER HOLDING SCREWS (1)

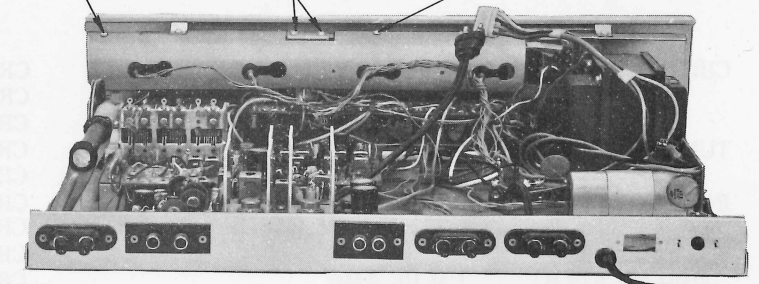

Fig. 7

6. Removal of circuit board.

Remove five screws holding RF-IF block, six screws holding AF block, two screws holding power block and two screws holding equalizer block shown in Fig. 5.

Remove four nuts holding rotary switches shown in Fig. 8.

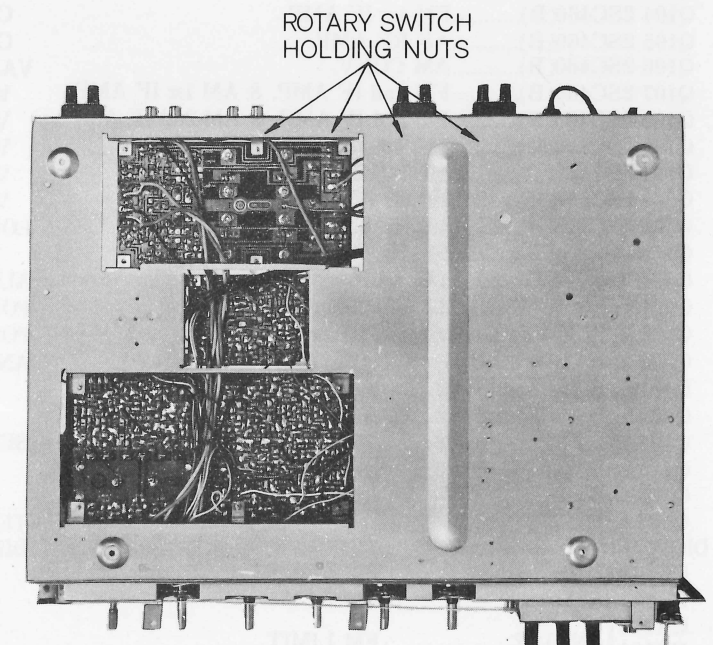

Fig. 8

DIAL CORD STRINGING

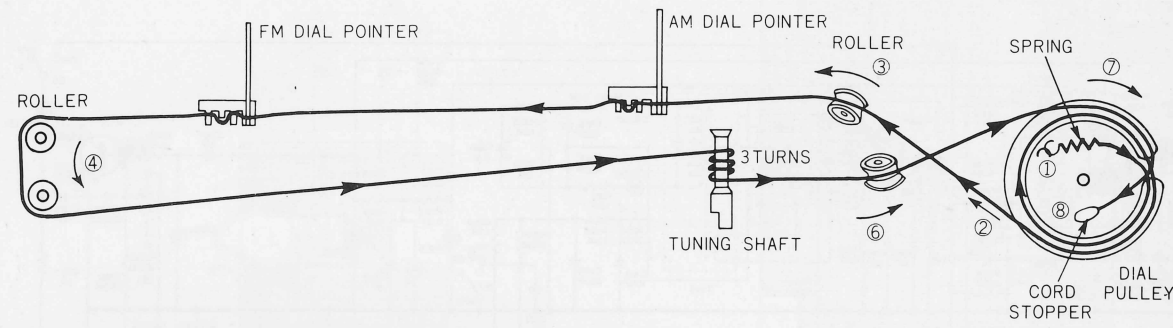

Fig. 9

INTERNAL VIEW

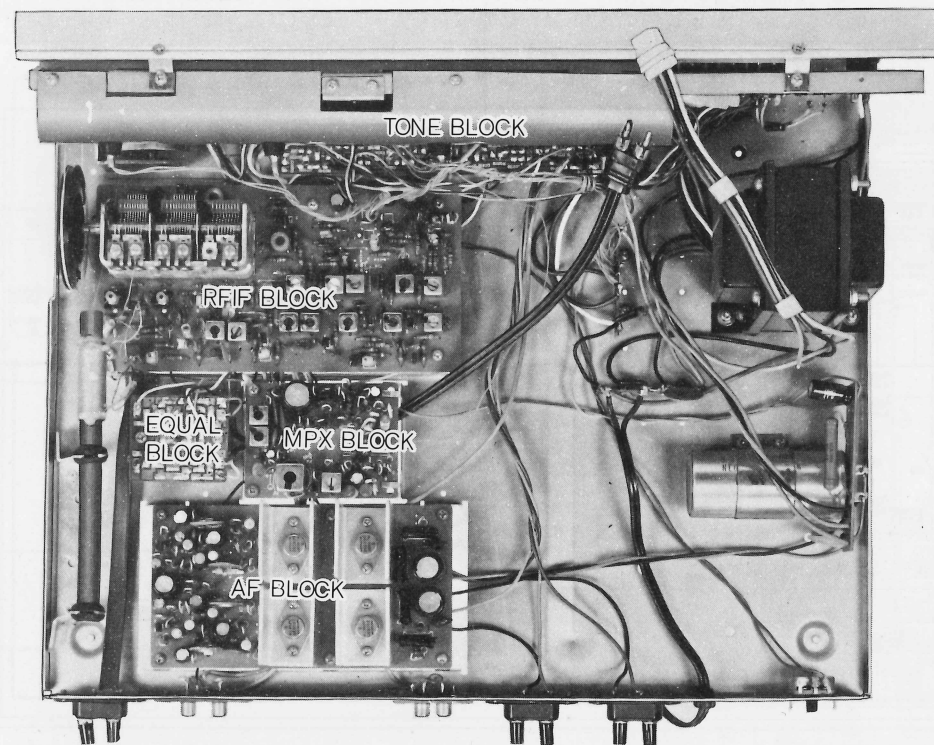

Fig. 10

REPLACEMENT PARTS

Symbol No.	Stock No.	Description	Symbol No.	Stock No.	Description
CAPACITORS:					
C 001	0244571	Ceramic	C 154	0275113	Same as C134
C 002	0244571	Same as C001	C 155	0275111	Same as C132
C 003	0259707	Electrolytic	C 156	0252513	Electrolytic
C 004	0252631	Electrolytic	C 157	0275113	Same as C134
C010A,B	0257039	Electrolytic	C 158	0275111	Same as C132
C021A,B	0252613	Electrolytic	C 159	0275115	Mylar
C 022	0252632	Electrolytic	C 160	0275113	Same as C134
C023A,B	0252223	Electrolytic	C 161	0244171	Same as C105
C024A,B	0252613	Same as C021A,B	C 162	0244171	Same as C105
C025A,B	0274111	Mylar	C 163	0244171	Same as C105
C026A,B	0275115	Mylar	C 164	0248669	Ceramic
C027A,B	0275113	Mylar	C 165	0248641	Same as C121
C028A,B	0252613	Same as C021A,B	C 166	0248724	Same as C133
C029A,B	0252613	Same as C021A,B	C 167	0248724	Same as C133
C030A,B	0275111	Mylar	C 168	0252613	Same as C156
C031A,B	0274115	Mylar	C 169	0248724	Same as C133
C032A,B	0275115	Same as C026A,B	C 170	0248724	Same as C133
C033A,B	0275113	Same as C027A,B	C 171	0276111	Mylar
C034A,B	0276113	Mylar	C 172	0275113	Same as C134
C035A,B	0248716	Ceramic	C 173	0275113	Same as C134
C037A,B	0274111	Same as C025A,B	C 174	0252531	Electrolytic
C 101	0248710	Ceramic	C 181	0274111	Mylar
C 102	0248645	Ceramic	C 182	0252525	Electrolytic
C 103	0248706	Ceramic	C 185	0248643	Same as C109
C 104	0248646	Ceramic	C 187	0248643	Same as C109
C 105	0244171	Ceramic	C 188	0275113	Mylar
C 106	0244171	Same as C105	C 189	0252525	Electrolytic
C 107	0244171	Same as C105	C 301	0274111	Mylar
C 108	0248706	Same as C103	C 302	0248696	Ceramic
C 109	0248643	Ceramic	C 303	0248694	Ceramic
C 110	0244161	Ceramic	C 304	0248736	Ceramic
C 111	0244171	Same as C105	C 305	0252613	Electrolytic
C 112	0244171	Same as C105	C 306	0252621	Electrolytic
C 113	0248643	Same as C109	C 307	0221351	Polystyrol
C 114	0244171	Same as C105	C 309	0252535	Electrolytic
C 115	0244161	Same as C110	C 310	0221351	Same as C307
C 116	0248716	Ceramic	C 311	0221351	Same as C307
C 117	0246430	Ceramic	C 312	0252621	Same as C306
C 118	0246428	Ceramic	C 313	0221339	Polystyrol
C 119	0248645	Same as C102	C 314	0274111	Same as C301
C 120	0244171	Same as C105	C 315	0274111	Same as C301
C 121	0248641	Ceramic	C 316	0274111	Same as C301
C 122	0244173	Ceramic	C 317	0274111	Same as C301
C 123	0244175	Ceramic	C 318	0274111	Same as C301
C 124	0244173	Same as C122	C 319	0274111	Same as C301
C 125	0244171	Same as C105	C 320	0275113	Mylar
C 126	0244171	Same as C105	C 321	0275113	Same as C320
C 127	0248645	Same as C102	C 322	0275115	Mylar
C 128	0244171	Same as C105	C 323	0275115	Same as C322
C 129	0244171	Same as C105	C 324	0275113	Same as C320
C 130	0248646	Same as C104	C 325	0275115	Same as C322
C 131	0248645	Same as C102	C401A,B	0252613	Electrolytic
C 132	0275111	Mylar	C 402	0252532	Electrolytic
C 133	0248724	Ceramic	C403A,B	0252231	Electrolytic
C 134	0275113	Mylar	C404A,B	0252613	Same as C401A,B
C 135	0248645	Same as C102	C405A,B	0252231	Same as C403A,B
C 136	0275113	Same as C134	C406A,B	0248726	Ceramic
C 137	0274115	Mylar	C407A,B	0252625	Electrolytic
C 138	0275111	Same as C132	C408A,B	0248734	Ceramic
C 139	0248724	Same as C133	C409A,B	0252635	Electrolytic
C 140	0241868	Ceramic	C410A,B	0275115	Mylar
C 141	0221339	Styrol	C601A,B	0252613	Electrolytic
C 142	0275113	Same as C134	C603A,B	0252613	Same as C601A,B
C 143	0274115	Same as C137	C606	0252531	Electrolytic
C 144	0274111	Mylar	C607A,B	0248734	Ceramic
C 145	0275113	Same as C134	C608A,B	0252613	Same as C601A,B
C 146	0248641	Same as C121	C609A,B	0275114	Mylar
C 147	0275113	Same as C134	C610A,B	0274116	Mylar
C 148	0248643	Same as C109	CT101		
C 149	0248650	Ceramic	CV101~106	0281557	Variable resistor
C 150	0274111	Same as C144	CT102	0281557	Variable resistor
C 151	0275113	Same as C134	CT103	0283113	Trimmer
C 152	0275113	Same as C134	CT104	0281557	Variable resistor
C 153	0248643	Same as C109			

MODEL KS-3200R SERVICE MANUAL

CIRCUIT DIAGRAM

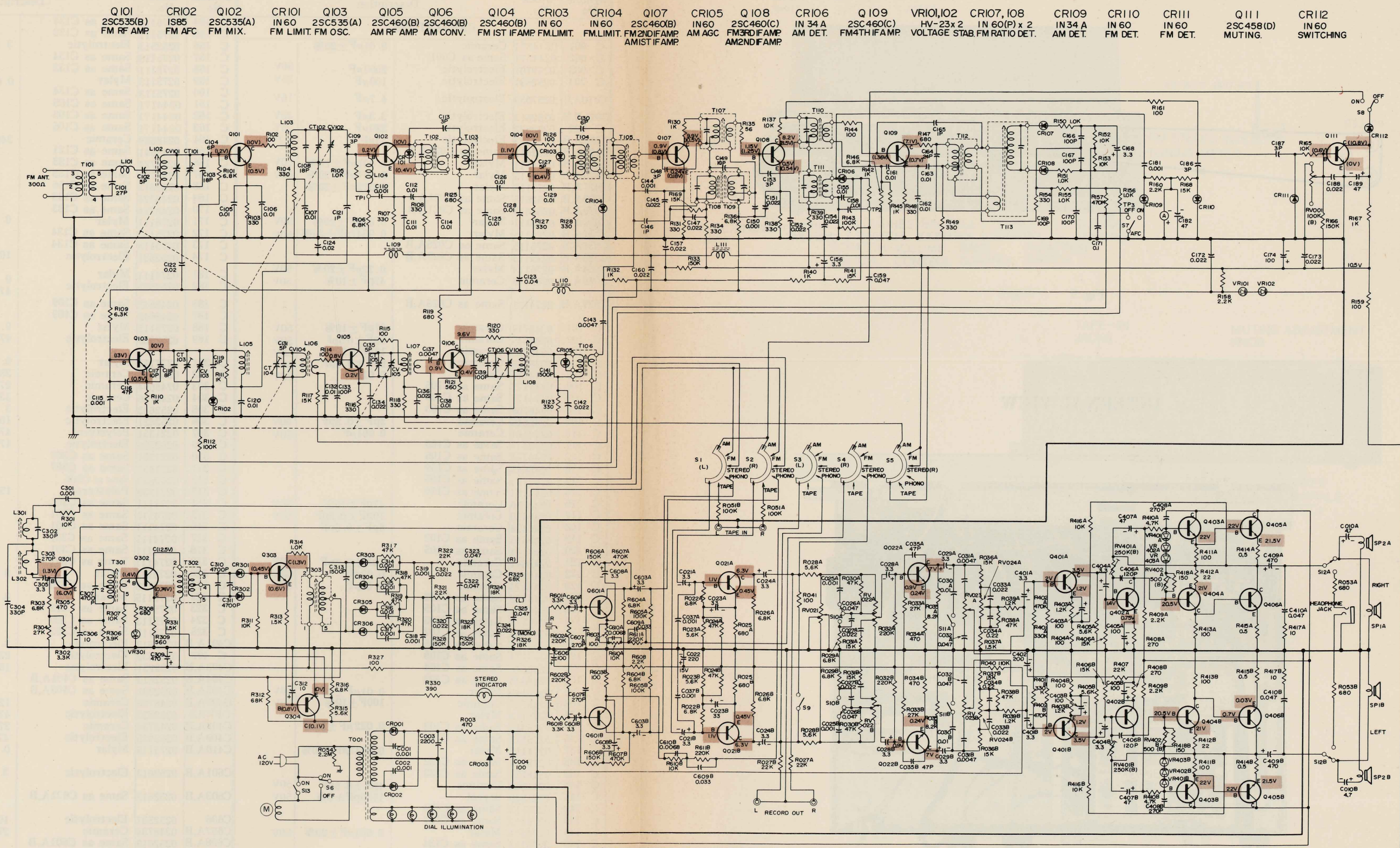

- | | | | | | | | | | | | | | | | | | | | | | |
|--------------------------------|-------------------------|------------------------------|-------------------------------------|--|--------------------------------|-------------------------------|--|---------------------------------------|---|-----------------------------|---------------------------------|------------------------------------|-----------------------------|------------------------------------|---|---|-----------------------------|---------------------------|---------------------------|------------------------------|-----------------------------|
| Q101
2SC535(B)
FM RF AMP | CR102
IS85
FM AFC | Q102
2SC535(A)
FM MIX. | CR101
IN 60
FM LIMIT. FM OSC. | Q103
2SC535(A)
FM LIMIT. FM OSC. | Q105
2SC460(B)
AM RF AMP | Q106
2SC460(B)
AM CONV. | Q104
2SC460(B)
FM 1ST IFAMP. FM LIMIT. | CR103
IN 60
FM LIMIT. FM LIMIT. | CR104
IN 60
FM LIMIT. FM 2ND IFAMP. | Q107
2SC460(B)
AM AGC | CR105
IN 60
FM 3RD IFAMP. | Q108
2SC460(C)
AM 2ND IFAMP. | CR106
IN 34 A
AM DET. | Q109
2SC460(C)
FM 4TH IFAMP. | VR101,102
HV-23 x 2
VOLTAGE STAB. FM RATIO DET. | CR107, 108
IN 60(P) x 2
FM RATIO DET. | CR109
IN 34 A
AM DET. | CR110
IN 60
FM DET. | CR111
IN 60
FM DET. | Q111
2SC458(D)
MUTING. | CR112
IN 60
SWITCHING |
|--------------------------------|-------------------------|------------------------------|-------------------------------------|--|--------------------------------|-------------------------------|--|---------------------------------------|---|-----------------------------|---------------------------------|------------------------------------|-----------------------------|------------------------------------|---|---|-----------------------------|---------------------------|---------------------------|------------------------------|-----------------------------|

- | | | | | | | | | | | | | | | | | | |
|--------------------------------|---------------------------------|--------------------------------|-------------------------------------|----------------------------|-----------------------------|--|---------------------------------|----------------------------------|-------------------------------------|---|---|-------------------------------------|-------------------------------------|--|---------------------------------------|--|---|
| Q301
2SC458(B)
19KHz AMP | VR301
HV-23
VOLTAGE STAB. | Q302
2SC458(A)
19KHz AMP | CR301,302
IN 34 A x 2
DOUBLER | Q303
2SC458(B)
38KHz | Q304
2SC458(C)
DC AMP | CR303-306
IN 60(P) x 4
SWITCHING | CRO01,002
V 03C
RECTIFIER | CRO03
AW01-13
ZENNER DIODE | Q601A,B
2SC458LG x 2
PRE. AMP | Q201A,021B
2SC458LG(C) x 2
PRE. AMP | Q202A,022B
2SC458LG(B) x 2
PRE. AMP | Q401A,401B
2SC458(B) x 2
AF 1 | Q402A,402B
2SC984(C) x 2
AF 2 | VR 401A, 401B
VR 402A, 402B
VR 403A, 403B
HV-23 x 6
TEMP COMPENSATOR | Q403A,403B
2SC984(B) x 2
DRIVER | Q404A, 404B
2SA565(B) x 2
DRIVER | Q405A,405B
Q406A,406B
2SC830 x 4
POWER AMP |
|--------------------------------|---------------------------------|--------------------------------|-------------------------------------|----------------------------|-----------------------------|--|---------------------------------|----------------------------------|-------------------------------------|---|---|-------------------------------------|-------------------------------------|--|---------------------------------------|--|---|

CIRCUIT BOARD DIAGRAM

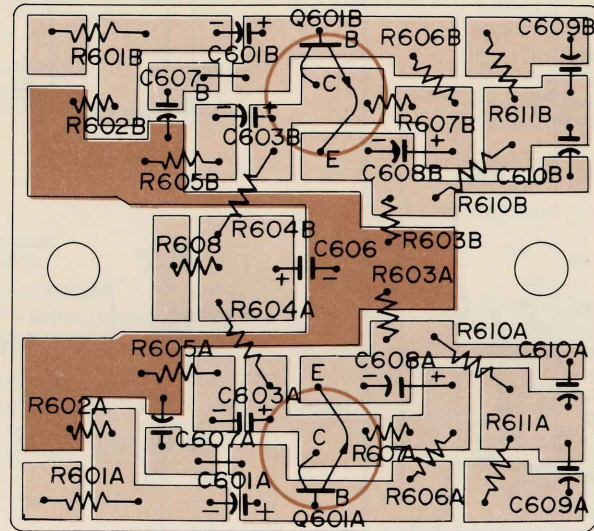

(EQUAL. BLOCK)

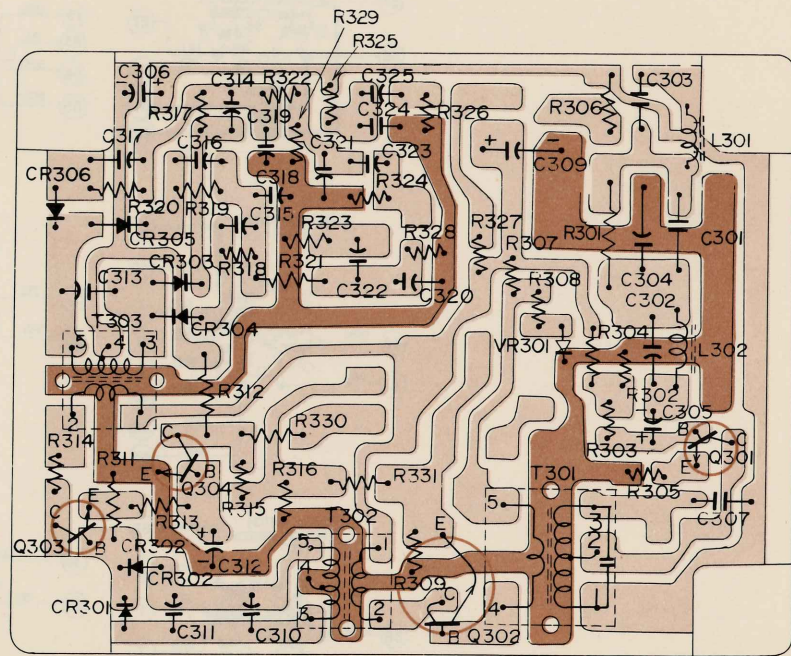

(MPX. BLOCK)

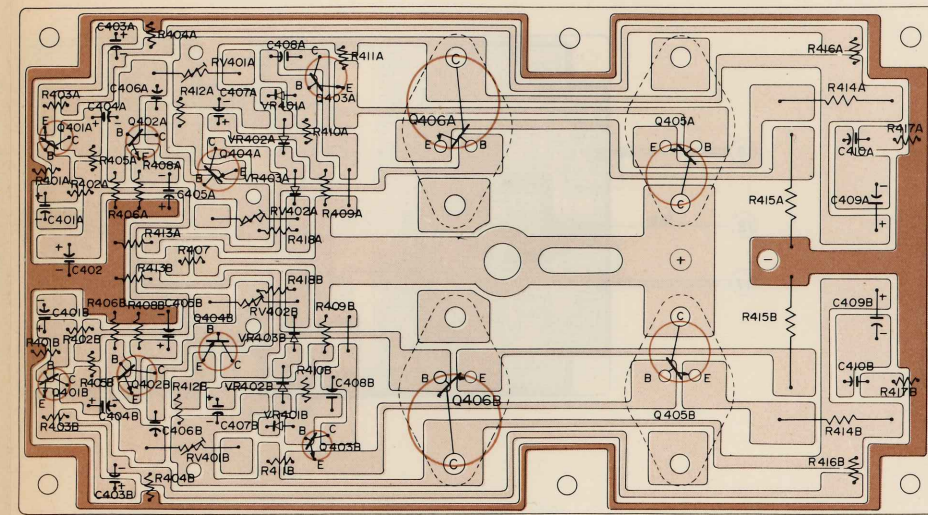

(AF BLOCK)

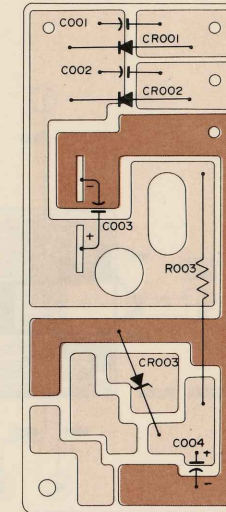

(POWER BLOCK)

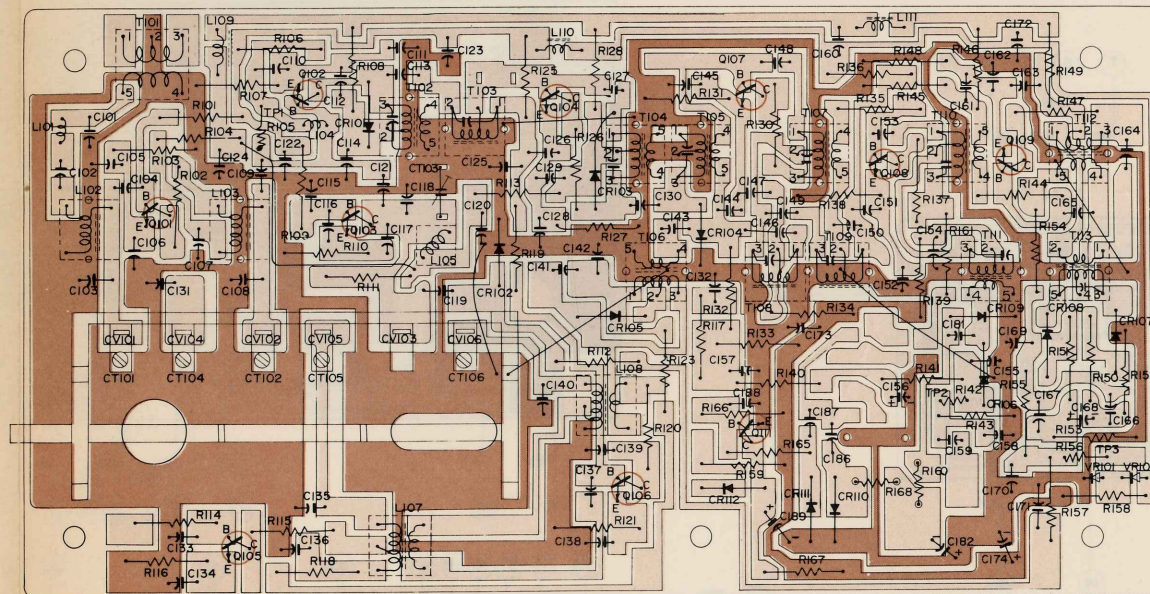

(RF - IF BLOCK)

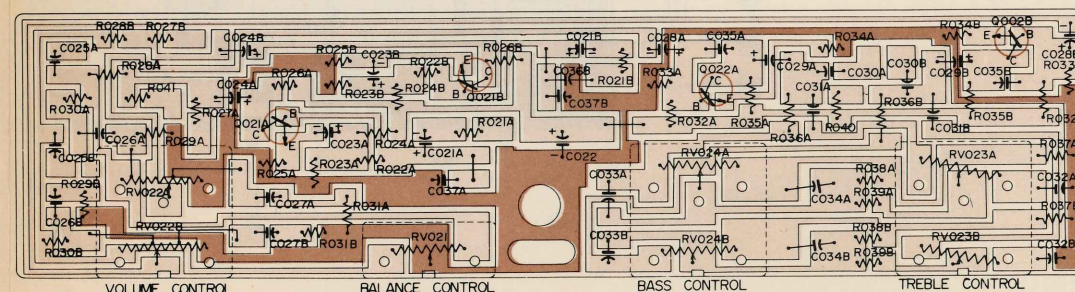

(TONE BLOCK)

WIRING DIAGRAM

