

# HITACHI SERVICE MANUAL

TY

No. 588 EGF

**MD30** (HRD-MD30  
HT-MD30/HT-MD30X)  
[US, CS, ES, ZS, BS, SA, EW]

TN-21SW-985-1 chassis

## HRD-MD30

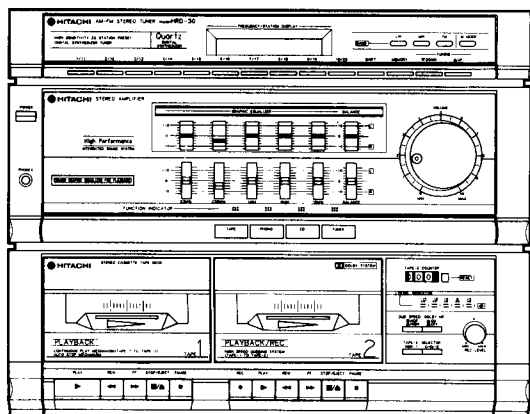

## HT-MD30/MD30X

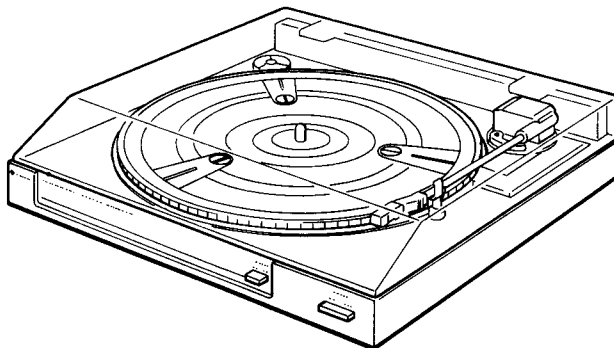

### CONTENTS

SPECIFICATIONS .....	2
DISASSEMBLY .....	5
ADJUSTMENTS .....	8
INSPECTION OF MECHANISM .....	10
LUBRICATION .....	17
MAINTENANCE .....	18
DIFFERENCE FOR DESTINATION .....	18
CIRCUIT DIAGRAM .....	21-26
PRINTED WIRING BOARD .....	27-30
WIRING DIAGRAM .....	31
EXPLODED VIEW .....	33
REPLACEMENT PARTS LIST .....	37

### INHALTSVERZEICHNIS

TECHNISCHEN DATEN .....	3
DEMONTAGE .....	5
EINSTELLUNGEN .....	11
PRÜFUNG DES LAUFWERKS .....	13
SCHMIERUNG .....	17
PFLEGE DES GERÄTS .....	18
UNTERSCHIEDE NACH BESTIMMUNGSLÄNDERN .....	18
SCHALTPLAN .....	21-26
PRINTPLATTEN .....	27-30
VERDRAHTUNGSSCHEMA .....	31
EXPLOSIONANSICHT .....	33
ERSATZTEILLISTE .....	37

### TABLE DES MATIERES

CARACTÉRISTIQUE TECHNIQUES .....	4
DÉMONTAGE .....	6
RÉGLAGE .....	14
INSPECTION DU MECANISME .....	16
LUBRIFICATION .....	17
ENTRETIEN .....	18
DIFFÉRENCE EN FONCTION DU PAYS DE DESTINATION .....	18
PLAN DE CIRCUIT .....	21-26
PLAN DE BASE .....	27-30
SCHÉMA DE CÂBLAGE .....	31
VUE EXPLOSEE .....	33
TABEAU DES PIÈCES .....	37

### SAFETY PRECAUTIONS

The following precautions should be observed when servicing.

1. Since many parts in the unit have special safety-related characteristics, always use genuine Hitachi's replacement parts. Especially critical parts in the power circuit block should not be replaced with other makers. Critical parts are marked with  $\triangle$  in the circuit diagram and printed wiring board.
2. Before returning a repaired unit to the customer, the service technician must thoroughly test the unit to ascertain that it is completely safe to operate without danger of electrical shock.

SPECIFICATIONS AND PARTS ARE SUBJECT TO CHANGE FOR IMPROVEMENT.

## STEREO TUNER-AMPLIFIER DOUBLE CASSETTE RECORDER

June 1988

YOKOHAMA WORKS

# SPECIFICATIONS

## HRD-MD30

### ● GENERAL

<b>Power supply:</b>	AC120V, 60 Hz [for US, CS] AC220V, 50 Hz [for ES, ZS] AC240V, 50 Hz [for BS, SA] AC110—120/200—220/230—240V, 50/60 Hz [for EW]
<b>Power consumption:</b>	85W [for BS] 145W [for US, CS] 180W [except BS, US, CS] 370 (W) x 296 (H) x 300 (D) mm 5.7 kg [for BS] 6.6 kg [for SA] 6.5 kg [except BS, SA]
<b>Dimensions:</b>	
<b>Weight:</b>	

### ● AMPLIFIER SECTION

<b>Audio output:</b>	10W x 2 (8 ohms, T.H.D. 5% both channel driven, 1 kHz) [for BS] 30 Watts* per channel, min. RMS. at 8 ohms from 100 Hz to 10 kHz, with more than 2% total harmonic distortion. [for US, CS] 30W x 2 (8 ohms, T.H.D. 5% both channel driven, 1 kHz) [except BS, US, CS]
<b>Music power output:</b>	60W x 2 (8 ohms, 1 kHz) [except BS]
<b>Tone control:</b>	±8 dB (at 63 Hz, 250 Hz, 1 kHz, 4 kHz, 16 kHz)
<b>Input sensitivity and Impedance:</b>	PHONO 3.5 mV/50 kohms [except BS] PHONO 240 mV/760 kohms [for BS] CD 200 mV/30 kohms
<b>Signal to noise ratio: (IHF-A network)</b>	PHONO 70 dB CD 80 dB
<b>Output impedance:</b>	Speaker 8—16 ohms Headphones 8 ohms

### ● TUNER SECTION

<b>Circuit system:</b>	FM/AM 2 bands superheterodyne [except BS, ES] FM/MW/LW 3 bands superheterodyne [for BS, ES]
<b>Tuning range:</b>	FM 87.5—108 MHz (50 kHz steps) [except US, CS, SA] 87.9—107.9 MHz (100 kHz steps) [for US, CS, SA] AM (MW) 522—1,611 kHz (9 kHz steps) [except US, CS, EW] 530—1,620 kHz (10 kHz steps) [for US, CS] 522—1,611/530—1,620 kHz (9/10 kHz steps) [for EW] LW 153—281 kHz (1 kHz steps) [for BS, ES]

<b>FM stereo separation:</b>	30 dB
<b>Sensitivity:</b>	FM 1 $\mu$ V (S/N 26 dB) [except US, CS] 1 $\mu$ V (S/N 30 dB) [for US, CS] AM(MW) 600 $\mu$ V/m (S/N 20dB) LW 2,500 $\mu$ V/m (S/N 20dB) [for BS, ES]
<b>FM signal to noise ratio:</b>	60 dB
<b>Antennas:</b>	FM: External antenna (aerial) AM(MW/LW): Loop antenna outdoor antenna

### ● TAPE DECK SECTION

<b>Tape:</b>	Cassette tape
<b>Tape speed:</b>	4.75 cm/s
<b>Recording system and bias frequency:</b>	AC bias, 85 kHz
<b>Track system:</b>	4 tracks 2 channels
<b>Erasing system:</b>	AC erase
<b>Frequency Response:</b>	Normal 70—14,000 Hz CrO <sub>2</sub> 70—14,000 Hz
<b>Signal to noise ratio:</b>	Dolby NR ON 58 dB OFF 50 dB
<b>Crosstalk:</b>	60 dB
<b>Erase ratio:</b>	65 dB
<b>Motor:</b>	DC motor
<b>Wow and Flutter:</b>	0.25% (WRMS)

\*Measured pursuant to the Federal Trade Commission's Trade Regulation Rule on Power Claims for Amplifiers.

## HT-MD30/HT-MD30X

**Note: HT-MD30X is for MD30 BS use**

<b>Type:</b>	2 speed, belt drive system
<b>Platter:</b>	295 mm
<b>Motor:</b>	DC motor
<b>Speed:</b>	2 speed; 33-1/3 and 45 rpm.
<b>Signal to noise ratio:</b>	56 dB (DIN-B)
<b>Wow and flutter:</b>	0.07% (WRMS)
<b>Tonearm Effective length:</b>	205 mm
<b>Cartridge type</b>	Magnetic (HT-MD30) Ceramic (HT-MD30X)
<b>Frequency response:</b>	25—20,000 Hz
<b>Output voltage:</b>	1.8—3.5 mV at 1 kHz, 50 mm/sec (HT-MD30) 500 mV at 1 kHz, 50 mm/sec (HT-MD30X)
<b>Stylus tip:</b>	Diamond stylus (N-5732) (HT-MD30) (N-800-4) (HT-MD30X)
<b>Tracking force:</b>	3.5 ± 1 g
<b>Channel separation:</b>	more than 15 dB
<b>Power supply:</b>	DC 12V (Secondary supply from HRD-MD30)
<b>Power Consumption:</b>	1.5W
<b>Dimensions:</b>	370 (W) x 340 (D) x 89 (H) mm
<b>Weight:</b>	3 kg

## HS-MD30

<b>Speaker unit:</b>	16 cm woofer + 5 cm tweeter
<b>Enclosure type:</b>	Bass reflex type
<b>Dimensions:</b>	230 (W) x 363 (H) x 185 (D) mm
<b>Weight:</b>	2.8 kg

## SICHERHEITSMASSNAHMEN

Bei Wartungsarbeiten sind die folgenden Sicherheitsmaßnahmen zu beachten:

- Da verschiedene Teile dieses Gerätes Sicherheitsfunktionen aufweisen, nur Original-Hitachi-Ersatzteile verwenden.

Kritische Teile im Netzteil sollten nicht durch ähnliche Teile anderer Hersteller ersetzt werden. Alle kritischen Teile sind im Schaltplan und im Printplatten mit dem Symbol  $\triangle$  gekennzeichnet.

- Vor der Auslieferung eines reparierten Gerätes an den Kunden muß der Wartungstechniker das Gerät einer gründlichen Prüfung unterziehen, um sicherzustellen, daß sicherer Betrieb ohne die Gefahr von elektrischen Schlägen gewährleistet ist.

**TECHNISCHEN DATEN****HRD-MD30****● GENERALE**

<b>Spannungsversorgung:</b>	AC120V, 60 Hz [für US, CS] AC220V, 50 Hz [für ES, ZS] AC240V, 50 Hz [für BS, SA] AC110—120/200—220/230—240V, 50/60 Hz [für EW]
<b>Leistungsaufnahme:</b>	85W [für BS] 145W [für US, CS] 180W [außer BS, US, CS]
<b>Abmessungen:</b>	370 (B) x 296 (H) x 300 (T) mm
<b>Gewicht:</b>	5.7 kg [für BS] 6.6 kg [für BS] 6.5 kg [außer BS, SA]

**● VERSTÄRKER TEIL**

<b>Audio ausgang:</b>	10W x 2 (8 Ohm, klirrgrad 5% beide Kanäle angesteuert 1 kHz) [für BS] Je Kanal mindestens 30W* (effektiv) bei 8 Ohm von 100 Hz bis 10 kHz, Gesamtklirrfaktor über 2% [für US, CS] 30W x 2 (8 Ohm, klirrgrad 5% beide kanäle angesteuert 1 kHz) [außer BS, US, CS]
<b>Musik-Ausgangsleistung:</b>	60W x 2 (8 Ohm, 1 kHz) [außer BS]
<b>Klangregelung:</b>	±8 dB (bei 63 Hz, 250 Hz, 1 kHz, 4 kHz, 16 kHz)
<b>Eingangsempfindlichkeit und Impedanz:</b>	PHONO 3,5 mV/50 kOhm [außer BS] PHONO 240 mV/760 kOhms [für BS] CD 200mV/30 kOhm
<b>Störspannungsabstand (IHF-A Network):</b>	PHONO 70 dB CD 80 dB
<b>Ausgangsimpedanz:</b>	Lautsprecher 8—16 Ohm Kopfhörer 8 Ohm

\*Wurde gemäß den Handelsbestimmungen des Bundeschandauftrags für Ausgangsleistungsansprüche von Verstärkern gemessen.

**● TUNER-TEIL**

<b>Schaltkreissystem:</b>	UKW/AM 2 Wellenbereiche Superhet [außer BS, ES] UKW/MW/LW 3 Wellenbereiche Superhet [für BS, ES]
<b>Abstimmbereich:</b>	UKW 87,5—108 MHz (50 kHz Kanallabstand) [außer US, CS, SA] 87,9—107,9 MHz (100 kHz Kanallabstand) [für US, CS, SA] AM(MW) 522—1611 kHz (9 kHz Kanallabstand) [außer US, CS, EW] 530—1620 kHz (10 kHz Kanallabstand) [für US, CS] 522—1611/530—1620 kHz (9/10 kHz Kanallabstand) [für EW] LW 153—281 kHz (1 kHz Kanallabstand) [für BS, ES]

<b>UKW-Stereotrennung:</b>	30 dB
<b>Empfindlichkeit:</b>	UKW 1 $\mu$ V (Storspannungsabstand 26 dB) [außer US, CS] 1 $\mu$ V (Storspannungsabstand 30 dB) [für US, CS] AM(MW) 600 $\mu$ V/m (Storspannungsabstand 20 dB) LW 2500 $\mu$ V/m (Storspannungsabstand 20 dB) [für BS, SA]

<b>UKW-Störspannungsverhältnis:</b>	60 dB
<b>Antenne:</b>	UKW: Externe Antenne AM(MW/LW): Rahmenantenne Außenantenne

**● KASSETTENDECK-TEIL**

<b>Band:</b>	Kassettenband
<b>Bandgeschwindigkeit:</b>	4,75 cm/sek
<b>Aufnahmesystem und Vormagnetisierungsfrequenz:</b>	Wechselstrom-Vormagnetisierung 85 kHz
<b>Spursystem:</b>	4-Spur 2-Kanal
<b>Löschsystem:</b>	Wechselstromlöschung
<b>Frequenzgang:</b>	Normal 70—14000 Hz CrO <sub>2</sub> 70—14000 Hz
<b>Störspannungsverhältnis:</b>	Mit Dolby NR 58 dB Ohne Dolby NR 50 dB
<b>Übersprechdämpfung:</b>	60 dB
<b>Löschverhältnis:</b>	65 dB
<b>Motor:</b>	Gleichstrommotor
<b>Gleichlaufschwankungen:</b>	0.25 % (WRMS)
*Wurde gemäß den Handelsbestimmungen des Bundeschandauftrags für Ausgangsleistungsansprüche von Verstärkern gemessen.	

**HT-MD30/HT-MD30X**

**Hinweis: HT-MD30X ist für die Verwendung mit MD30 BS bestimmt.**

<b>Typ:</b>	Reimenantrieb mit 2 Drehzahlen
<b>Plattenteller:</b>	295 mm
<b>Motor:</b>	Gleichstrom-motor
<b>Drehzahlen:</b>	2 Geschwindigkeiten; 33-1/3 und 45 U/min
<b>Störabstand:</b>	56 dB (DIN-B)
<b>Gleichlaufschwankungen:</b>	0,07% (WRMS)
<b>Tonarm Effektive länge:</b>	205 mm
<b>Tonabnehmer:</b>	Magnettyp (HT-MD30) Keramik (HT-MD30X)
<b>Frequenzgang:</b>	25—20000 Hz
<b>Ausgangsspannung:</b>	1,8—3,5 mV bei 1 kHz, 50 mm/s. (HT-MD30) 500 mV bei 1 kHz, 50 mm/s. (HT-MD30X)
<b>Abtastnadel:</b>	Diamantnadel (N-5732) (HT-MD30) (N-800-4) (HT-MD30X)
<b>Auflagekraft:</b>	3,5 ± 1 g
<b>Kanaltrennung:</b>	über 15 dB
<b>Stromversorgung:</b>	12V Gleichspannung (Sekundäre Stromversorgung von HRD-MD30)
<b>Leistungsaufnahme:</b>	1,5W
<b>Abmessungen:</b>	370 (B) x 340 (T) x 89 (H) mm
<b>Gewicht:</b>	3 kg

**HS-MD30**

<b>Lautsprecher:</b>	16 cm tieftöner + 5 cm hoctöner
<b>Gehäuse:</b>	Tiefenreflexsystem
<b>Abmessungen:</b>	230 (B) x 363 (H) x 185 (T) mm
<b>Gewicht:</b>	2,8 kg

## PRÉCAUTIONS DE SÉCURITÉ

Les précautions suivantes doivent être observées chaque fois qu'une réparation doit être faite.

1. Etant donné que de nombreux composants de l'appareil possèdent des caractéristiques relatives à la sécurité, utiliser uniquement des pièces de rechange d'origine Hitachi pour effectuer un remplacement. Ceci se rapporte notamment aux pièces critiques du bloc d'alimentation qui ne doivent en aucun cas être remplacées par celles d'autres fabricants. Les pièces critiques sont accompagnés du symbole  $\triangle$  dans le plan de circuit et sur le plan de base.
2. Avant de retourner l'appareil répare au client le technicien doit procéder à un essai complet pour s'assurer qu'il ne présente aucun danger de chocs électriques.

## CARACTÉRISTIQUE TECHNIQUES

### HRD-MD30

#### ● GÉNÉRAL

<b>Alimentation:</b>	CA120V, 60 Hz [pour US, CS] CA220V, 50 Hz [pour ES, ZS] CA240V, 50 Hz [pour BS, SA] CA110—120/200—220/230—240V, 50/60 Hz [pour EW]
<b>Consommation électrique:</b>	85W [pour BS] 145W [pour US, CS] 180W [sauf BS, US, CS] 370 (L) x 296 (H) x 300 (P) mm
<b>Dimensions:</b>	
<b>Poids:</b>	5.7 kg [pour BS] 6.6 kg [pour SA] 6.5 kg [sauf BS, SA]

#### ● SECTION AMPLIFICATEUR

<b>Sortie audio:</b>	10W x 2 (8 ohms, D.H.T. 5% les deux canaux entraînent 1 kHz) [pour BS] 30 Watts* par canal, min. efficace, à 8 ohms de 100 Hz à 10 kHz, avec une distorsion harmonique totale inférieure à 2% [pour US, CS] 30W x 2 (8 ohms, D.H.T. 5% les deux canaux entraînent 1 kHz) [sauf BS, US, CS]
<b>Puissance gesortie musicale:</b>	60W x 2 (8 ohms, 1 kHz) [sauf BS]
<b>Contrôle de tonalité:</b>	$\pm 8$ dB (à 63 Hz, 250 Hz, 1 kHz, 4 kHz, 16 kHz)

#### Sensibilité et impédance

<b>d'entrée:</b>	PHONO 3,5 mV/50 kohms [sauf BS] PHONO 240 mV/760 kohms [pour BS] CD 200 mV/30 kohms
------------------	---

#### Rapport signal/bruit: (Réseau IHF-A)

<b>Impédance de sortie:</b>	Enceintes acoustiques 8—16 ohms Casque d'écoute 8 ohms
-----------------------------	---

#### ● SECTION TUNER

<b>Système de circuit:</b>	2 gammes, d'ondes MF/AM à superhétérodyne [sauf BS, ES] 3 gammes d'ondes MF/PO/GO à superhétérodyne [pour BS, ES]
<b>Plage d'accord:</b>	MF 87,5—108 MHz (Réglé sur 50 kHz) [sauf US, CS, SA] 87,9—107,9 MHz (Réglé sur 100 kHz) [pour US, CS, SA] AM(PO) 522—1611 kHz (Réglé sur 9 kHz) [sauf US, CS, EW] 530—1620 kHz (Réglé sur 10 kHz) [pour US, CS] 522—1611/530—1620 kHz (Réglé sur 9/10 kHz) [pour EW] GO 153—281 kHz (Réglé sur 1 kHz) [pour BS, ES]

<b>Séparation stéréo MF:</b>	30 dB
<b>Sensibilité:</b>	MF 1 $\mu$ V (S/B 26 dB) [sauf US, CS] 1 $\mu$ V (S/B 30 dB) [pour US, CS] AM(PO) 600 $\mu$ V/m (S/B 20 dB) GO 2500 $\mu$ V/m (S/B 20 dB) [pour BS, ES]
<b>Rapport signal/bruit MF:</b>	60 dB
<b>Antenne:</b>	MF: Antenne extérieure AM(PO/GO): Antenne cadre AM Antenne extérieure

#### ● SECTION MAGNETOCASSETTE

<b>Bande:</b>	Cassette
<b>Vitesse de défilement:</b>	4,75 cm/s
<b>Système d'enregistrement/ fréquence de polarisation:</b>	Polarisation CA, 85 kHz
<b>Système de piste:</b>	4 pistes 2 canaux
<b>Système d'effacement:</b>	Effacement CA
<b>Réponse en fréquence:</b>	Normal 70—14000 Hz CrO <sub>2</sub> 70—14000 Hz
<b>Rapport signal/bruit:</b>	Dolby NR, MARCHE 58 dB ARRÊT 50 dB
<b>Transmodulation:</b>	60 dB
<b>Taux d'effacement:</b>	65 dB
<b>Moteur:</b>	Moteur CC
<b>Pleurage et scintillement:</b>	0,25% (watts effic.)

\*Mesures conformes aux règlements commerciaux de la Federal Trade Commission relatifs à la puissance de sortie des amplificateurs.

### HT-MD30/HT-MD30X

**Note: Le HT-MD30X doit être utilisé avec le modèle MD30**

<b>Type:</b>	Système d'entraînement par courroie 2 vitesses
<b>Plateau:</b>	295 mm
<b>Moteur:</b>	Moteur CC
<b>Vitesse:</b>	2 vitesses; 33-1/3 et 45 t/mm
<b>Rapport signal/bruit</b>	56 dB (DIN-B)
<b>Pleurage et scintillement:</b>	0.07% (watts effic.)
<b>Bras de lecture Longueur réelle:</b>	205 mm
<b>Cellule:</b>	Aimant (HT-MD30) Céramique (HT-MD30X)
<b>Réponse de fréquence:</b>	25—20000 Hz
<b>Tention de sortie:</b>	1,8—3,5 mV à 1kHz, 50 mm/sec. (HT-MD30) 550 mV à 1kHz, 50 mm/sec. (HT-MD30X)
<b>Pointe de lecture:</b>	Diamant (N-5732) (HT-MD30) (N-800-4) (HT-MD30X)
<b>Force d'appui:</b>	3,5 $\pm$ 1 g
<b>Séparation de canal:</b>	plus de 15 dB
<b>Alimentation:</b>	CC12V (alimentation secondaire provenant de HRD-MD30)
<b>Consommation:</b>	1,5W
<b>Dimensions:</b>	370 (L) x 340 (D) x 89 (H) mm
<b>Poids:</b>	3 kg

### HS-MD30

<b>Haut-parleurs:</b>	16 cm woofer + 5 cm tweeter
<b>Type d'enceinte:</b>	Type bass reflex
<b>Dimensions extérieures:</b>	230 (L) x 363 (H) x 185 (P) mm
<b>Poids:</b>	2,8 kg

## DISASSEMBLY

### 1. Cover (Fig. 1)

Remove six screws ① and then remove four screws ②. Slide the cover in the direction of arrow A.

Caution: Removing the cover by lifting the bottom first may break the front panel tabs. Be sure to lift it straight up first before sliding the cover back.

### 2. Front Panel (Fig. 2, 9)

Remove two screws ③. Remove the power switch. Then remove two screws ④, three screws ⑤, one screw ⑥ and seven Audio P.W.B. connectors a. (Refer to Fig. 9 for connectors a.)

### 3. Display P.W.B. (Fig. 3)

Remove the volume knob. Then remove fifteen screws ⑦ and two tabs.

### 4. Headphones P.W.B. (Fig. 3)

Remove two screws ⑧.

### 5. Deck P.W.B. (Fig. 4, 5, 9)

Remove two screws ⑨, two screws ⑩, five connectors b and two connectors c. Open in the direction of arrow B. Next, remove the REC level knob, two screws ⑪ and one tab. (Refer to Fig. 9 for connectors c.)

### 6. Cassette Door (Fig. 6)

Remove two screws ⑫ and remove the damper. Next, press the cassette door OPEN button to open the cassette door. Then press the two arms in the direction of arrow C and pull out. (Do the same for Tape 2.)

### 7. Cassette Chassis (Fig. 7)

After removing the cassette doors, remove six screws ⑬ and remove the counter belt.

### 8. Power Supply P.W.B. (Fig. 8)

Remove four screws ⑭.

### 9. Audio P.W.B. (Fig. 9)

Remove six screws ⑮, one screw ⑯, two screws ⑰ and one connector d.

## DEMONTAGE

### 1. Abdeckung (Abb. 1)

Die sechs Schrauben ① und dann die vier Schrauben ② herausdrehen. Nun die Abdeckung in Pfeilrichtung A schieben.

Vorsicht: Wird beim Entfernen der Abdeckung zuerst das Unterteil angehoben können die Frontplattenklauen brechen. Daher die Abdeckung zuerst anheben und dann nach hinten schieben.

### 2. Frontplatte (Abb. 2, 9)

Die beiden Schrauben ③ herausdrehen und die Netz-taste abnehmen. Anschließend die beiden Schrauben ④, die drei Schrauben ⑤ und Schraube ⑥ herausdrehen und die sieben Steckverbinder a der Audio-Leiterplatte entfernen. (Steckverbinder a siehe Abb. 9.)

### 3. Display-Leiterplatte (Abb. 3)

Den Drehknopf des Lautstärkereglers abziehen und die fünfzehn Schrauben ⑦ und die beiden Klauen entfernen.

### 4. Kopfförer-Leiterplatte (Abb. 3)

Die beiden Schrauben ⑧ herausdrehen.

### 5. Deck-Leiterplatte (Abb. 4, 5, 9)

Die beiden Schrauben ⑨ und ⑩ herausdrehen und die fünf Steckverbinder b sowie die beiden Steckverbinder c abziehen. In Pfeilrichtung B öffnen. Danach den Drehknopf für Aufnahmepegel (REC) sowie die beiden Schrauben ⑪ und eine Klaue entfernen. (Steckverbinder c siehe Abb. 9.)

### 6. Cassettenfachdeckel (Abb. 6)

Die beiden Schrauben ⑫ herausdrehen und den Dämpfer abnehmen. Danach durch Drücken der Öffnen-Taste (OPEN) den Cassettenfachdeckel öffnen. Nun die beiden Arme in Pfeilrichtung C drücken und herausziehen. (Bei TAPE 2 ebenso vorgehen.)

### 7. Cassettenchassis (Abb. 7)

Nach Ausbau des Cassettenfachdeckels die sechs Schrauben ⑬ herausdrehen und den Zählwerkriemen abnehmen.

### 8. Netzteil-Leiterplatte (Abb. 8)

Die vier Schrauben ⑭ herausdrehen.

### 9. Audio-Leiterplatte (Abb. 9)

Die sechs Schrauben ⑮, Schraube ⑯ und beiden Schrauben ⑰ herausdrehen und Steckverbinder d abziehen.

# DÉMONTAGE

## 1. Couvercle (Fig. 1)

Enlever six vis ①, puis enlever quatre vis ②. Faire coulisser le couvercle dans la direction de la flèche A. Précaution: Le fait de dégager le couvercle en soulevant le bas en premier peut provoquer une rupture des attaches de panneau avant. Veiller à le soulever tout droit avant de faire coulisser le dos du couvercle.

## 2. Panneau avant (Fig. 2, 9)

Enlever deux vis ③. Enlever l'interrupteur d'alimentation. Puis enlever deux vis ④, trois vis ⑤, une vis ⑥ et sept connecteurs de plaquette audio a. (Se référer à la Fig. 9 pour les connecteurs a.)

## 3. Plaquette d'affichage (Fig. 3)

Enlever le bouton de volume. Puis enlever quinze vis ⑦ et deux attaches.

## 4. Plaquette de casque (Fig. 3)

Enlever deux vis ⑧.

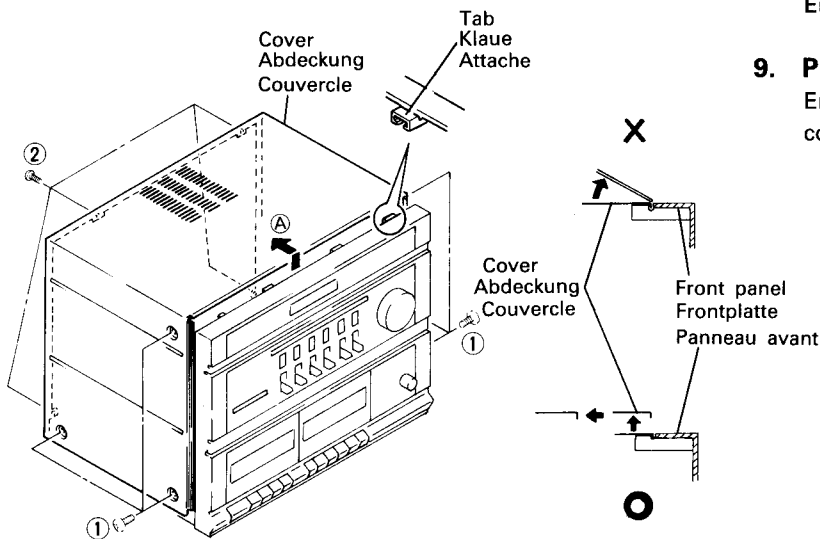

Fig. 1 Abb. 1

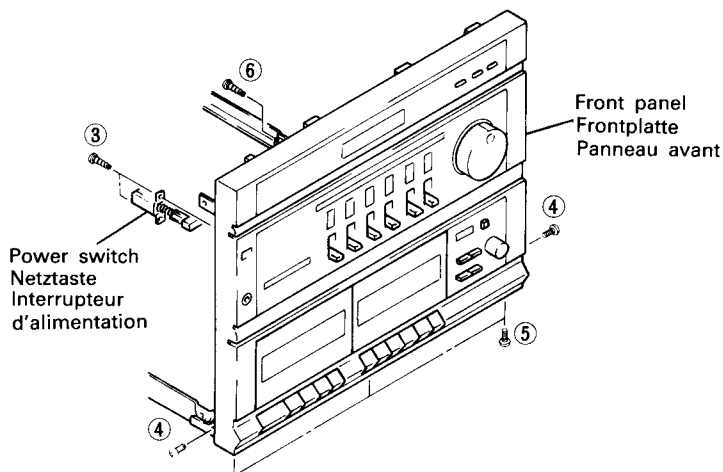

Fig. 2 Abb. 2

## 5. Plaquette platine (Fig. 4, 5, 9)

Enlever deux vis ⑨, deux vis ⑩, cinq connecteurs b et deux connecteurs c. Ouvrir dans la direction de la flèche B. Puis, enlever le bouton de niveau d'enregistrement (REC), deux vis ⑪ et une attache. (Se référer à la Fig. 9 pour les connecteurs c.)

## 6. Porte du logement cassette (Fig. 6)

Enlever deux vis ⑫ et enlever le dispositif d'amortissement. Puis, appuyer sur le bouton d'ouverture (OPEN) de la platine afin d'ouvrir la porte du logement cassette. Puis appuyer sur les deux bras dans la direction de la flèche C et tirer. (Suivre la même procédure pour la Platine 2.)

## 7. Châssis de cassette (Fig. 7)

Après avoir enlevé les portes du logement cassette, enlever six vis ⑬ et enlever la courroie du compteur.

## 8. Plaquette d'alimentation (Fig. 8)

Enlever quatre vis ⑭

## 9. Plaquette audio (Fig. 9)

Enlever six vis ⑮, une vis ⑯, deux vis ⑰ et un connecteur d.

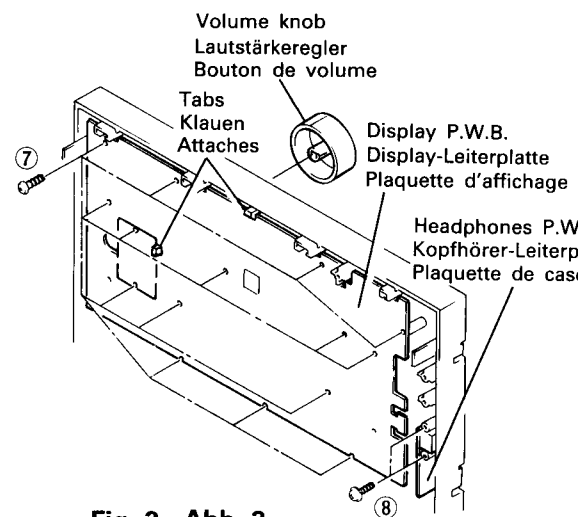

Fig. 3 Abb. 3

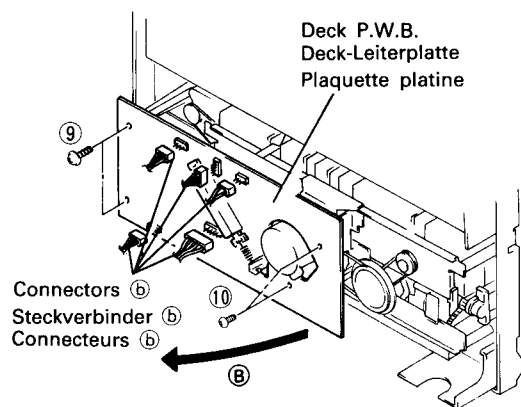

Fig. 4 Abb. 4

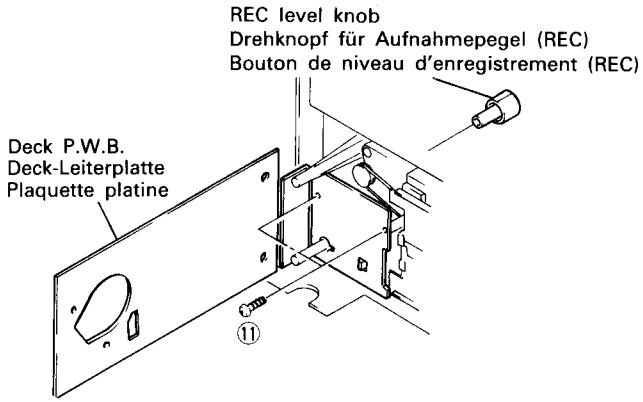

Fig. 5 Abb. 5

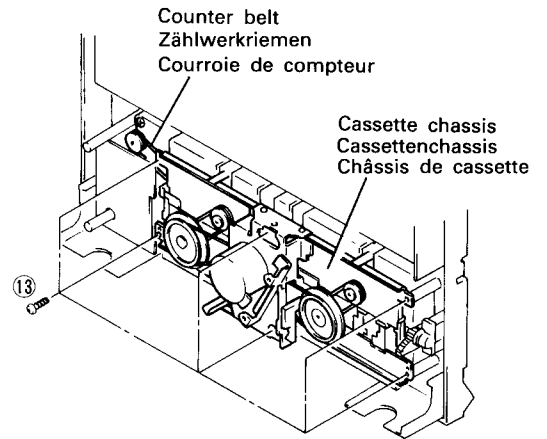

Fig. 7 Abb. 7

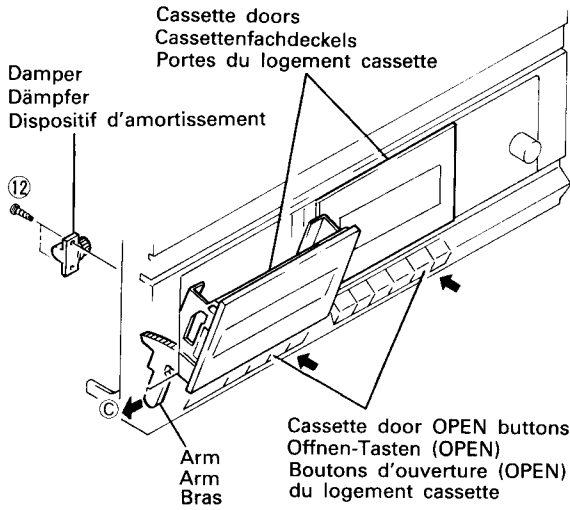

Fig. 6 Abb. 6

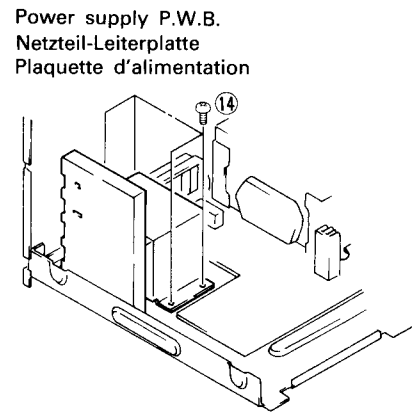

Fig. 8 Abb. 8

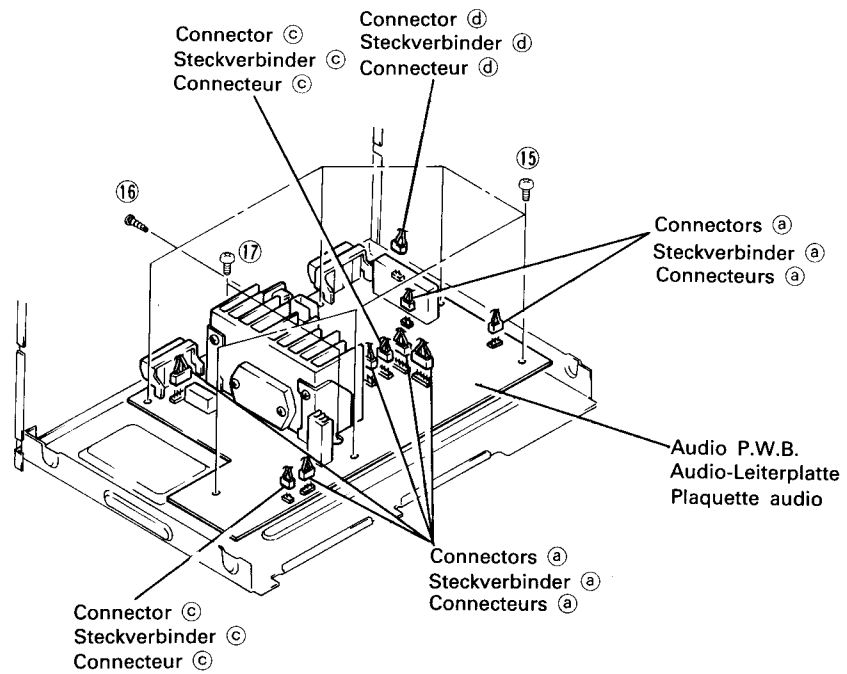

Fig. 9 Abb. 9

# ADJUSTMENTS

HRD-MD30

## 1. RADIO SECTION

- Adjustment points

### AUDIO P.W.B.

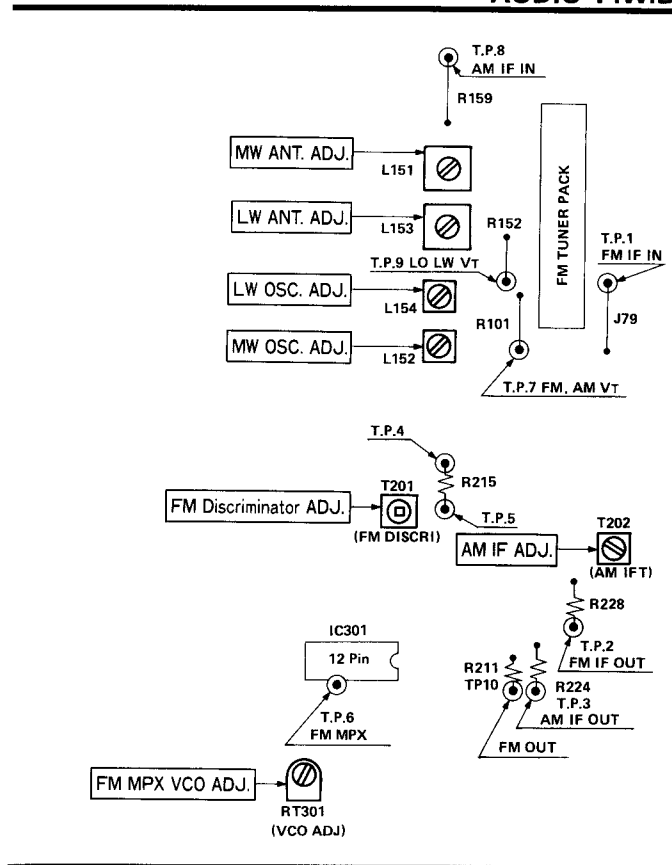

Fig. 10

### AM Section

Step	Adjustment Item	Measuring Instrument and Connection			Genescope or Signal Generator Frequency	Dial Pointer Position	Adjust	Reading
		Measuring Instrument	Input Terminal	Output Terminal				
1	(1) (2) AM IF	Genescope (455 kHz)	TP. 8	TP. 3	450 kHz	Highest	T202	Note 1
2	(1) MW OSC (Covering)	• AM signal generator (400 Hz, 30% mod.)	Loop antenna Note 2	TP. 7	522 kHz (except US, CS) 530 kHz (for US, CS)	Lowest	L152	1.2V (except US, CS) 1.25 V (for US, CS)
3	(1) MW ANT (Tracking)	• VTVM • Oscilloscope		SP. OUT		600 kHz	600 kHz	L151
4	(1) LW OSC (Covering)	• AM signal generator (400 Hz, 30% mod.)	Loop antenna Note 2	TP. 9	153 kHz	Lowest	L154	1.2V
5	(1) LW ANT (Tracking)	• VTVM • Oscilloscope		SP OUT		164 kHz	164 kHz	L153

### FM Section

Step	Adjustment Item	Measuring Instrument and Connection			Genescope or Signal Generator Frequency	Dial Pointer Position	Adjust	Reading
		Measuring Instrument	Input Terminal	Output Terminal				
1	(1) Discriminator	• DC balance meter (AUTO state)	FM ANT 400 Hz 22.5 kHz DEV. 60 dB	TP. 4(+) TP.5(-)	98 MHz	98 MHz	T201	0±10 mV
2	(1) MPX VCO (19 kHz)	Frequency counter	FM antenna terminal 75Ω 60 dB Non modulation	TP. 6 (Connect via 100 kΩ resistor)	98 MHz	98 MHz	RT301	19 kHz ± 50 Hz



**Note 1:** If the signal from the sweep generator is weak, make sure that the waveform becomes maximum and symmetrical as shown in Fig. 11.

Raise the level of the sweep generator, make sure that range at point A becomes as flat as possible as shown in Fig. 12.

**Note 2:** Initially set the input level to 74 dB/m, and lower the level to minimum as required (approx. 60 dB/m) for progress of the adjustment. And adjust repeatedly so that the output is maximum at the specified frequency. The trimmer condenser has been eliminated, so upper limit frequency tracking adjustment is unnecessary.

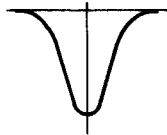

Fig. 11

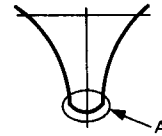

Fig. 12

**2. TAPE DECK SECTION**

● **Adjustment points**

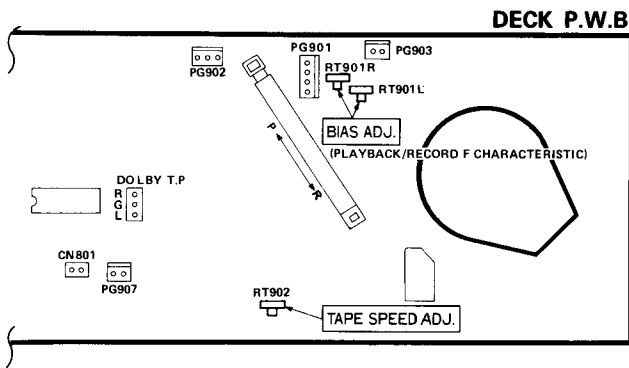

Fig. 13

Symbol No.	Switches and Controls	Position
S903	DOLBY NR	OFF
S902	TAPE SELECT SW	NOR
RV901	REC VOL	MAX
S991	RIF SW	A

Perform the following adjustments in the sequence stated after cleaning the head, pressure roller, and capstan with a head cleaning stick moistened in alcohol.

**(1) Head azimuth adjustment**

**Setting:** Playback mode.

**Connection:**

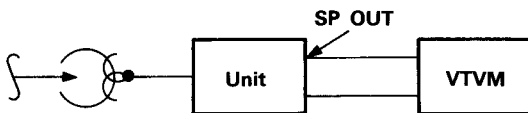

Fig. 14

**Adjustment:**

Playback test tape (10 kHz) and adjust the azimuth adjustment screw for maximum output however, if the peak level differs between the left and right channels, set it to the left-channel peak level. At this time, the difference between both channel peak levels should be within 2 dB.

After adjustment, lock the screw.

**(2) Frequency characteristic adjustment (Bias adj.)**

**Setting:** Recording/Playback mode

**Connection:**

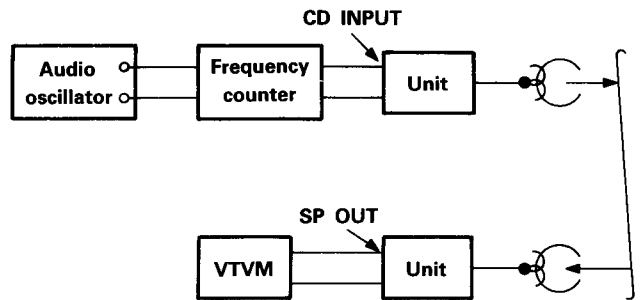

Fig. 15

**Adjustment:** Set the RT901LR to the center position beforehand.

① Record 400 Hz and 10 kHz signals at the level of -25 dB. Set the record mode, and if there is a difference of more than  $-25 \text{ dB} \pm 1.5 \text{ dB}$  in output, adjust RT901L, R. Measure the record/playback frequency characteristic of the test tape at the level of -25 dB. Then make sure that the measured value is within the range of the specification.

② Apply 400 Hz signal and adjust the audio oscillator until the meter reads -10 dB, and then record on tape. Playback the recorded tape and check that the output is within  $-10 \text{ dB} \pm 2 \text{ dB}$ .

**Note:** For CHROME and METAL tapes, make checks only.

**(3) Tape speed adjustment**

Item	Adjustment point	Procedure
Tape speed adjustment	RT902	Playback test tape (3000 Hz) in TAPE 2 and adjust. (Adjust NOR) NOR $\rightarrow 3000 \pm 30 \text{ Hz}$

Speed difference between TAPE 1 and TAPE 2 should be +70 to -40 Hz.

**HT-MD30/HT-MD30X**

**Speed adjustment (Fig. 16)**

If the specified speed cannot be obtained after replacing the motor, use the stroboscopic disk. (Adjustment is possible without removing the bottom plate.)

**Note:** Before adjustment, perform more than 10 minutes warmup with the turntable at 33-1/3 rpm. Carry out this adjustment in the order of (1) and (2).

- (1) Set the speed to 33-1/3 rpm, and adjust Ⓐ so as to obtain the rated speed (33-1/3 rpm.)
- (2) Set the speed of 45 rpm, and adjust Ⓑ so as to obtain the rated speed (45 rpm).

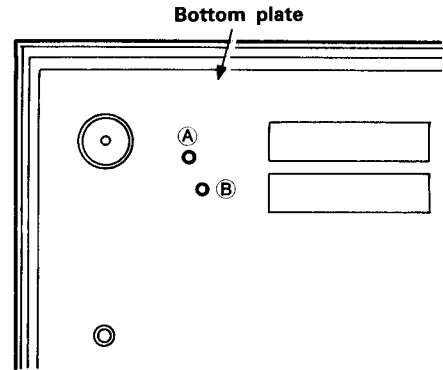

**Fig. 16**

**INSPECTION OF MECHANISM**

Item	Checking item	Reference value	Remarks
1	Pressure of pressure roller	300—500 g	Note
2	Take-up torque	30—60g·m	
3	Fast forward/Rewind torque	50g·cm or more	
4	Auto-Stop sensor operation force	40—75 g	
5	Brake torque	15 g·cm or more	Measured in stop mode
6	Back tension torque	Take-up	1—6 g·cm
		Supply	1—4 g·cm
7	Flywheel thrust gap	0.05—0.5 mm	
8	Button operation force	Play button	1.1 kg or less
		FF button	0.8 kg or less
		Rewind button	1.1 kg or less
		Eject button	0.6 kg or less
		Record button	1.0 kg or less
		Pause button	1.0 kg or less

**Note:**

Set this unit in the playback mode and press the pressure roller in the direction of the arrow using a fan type tension gauge, and measure the pressure when the pressure roller is released from the capstan.

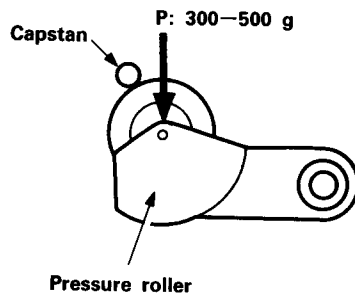

**Fig. 17**

# EINSTELLUNGEN

HRD-MD30

## 1. RADIOTEIL

### ● Einstellpunkte



Abb. 10

### MW-Teil

Schritt	Einstellteil	Meßgerät und Meßanschlüsse			Frequenz von Genescope oder Signalgenerator	Skalenanzeige	Einstellung an	Meßwert
		Meßgerät	Eingangsanschluß	Ausgangsanschluß				
1	(1) MW-Zwischenfrequenz (2)	Genescope (455 kHz)	Meßpunkt TP. 8	Meßpunkt TP. 3	450 kHz	Vollausschlag	T202	Hinweis 1
2	(1) MW-Oszillator (Abdeckung)	<ul style="list-style-type: none"> <li>MW-Signalgenerator (400 Hz, Modulationsgrad 30%)</li> <li>Röhrenvoltmeter</li> <li>Oszilloskop</li> </ul>	Schleifenantenne, Hinweis 2	Meßpunkt TP. 7	522 kHz (außer US und CS) 530 kHz (für US und CS)	Kleinstmöglicher Zeigerausschlag	L152	1,2 V (außer US and CS) 1,25 V (für US and CS)
3	(1) MW-Antenne (Nachlauf)	<ul style="list-style-type: none"> <li>Röhrenvoltmeter</li> <li>Oszilloskop</li> </ul>		SP., Ausgang		600 kHz	600 kHz	L151
4	(1) LW-Oszillator (Abdeckung)	<ul style="list-style-type: none"> <li>MW-Signalgenerator (400 Hz, Modulationsgrad 30%)</li> <li>Röhrenvoltmeter</li> <li>Oszilloskop</li> </ul>	Schleifenantenne, Hinweis 2	Meßpunkt TP. 9	153 kHz	Kleinstmöglicher Zeigerausschlag	L154	1.2 V
5	(1) LW-Antenne (Nachlauf)	<ul style="list-style-type: none"> <li>Röhrenvoltmeter</li> <li>Oszilloskop</li> </ul>		SP., Ausgang		164 kHz	164 kHz	L153

UKW-Teil

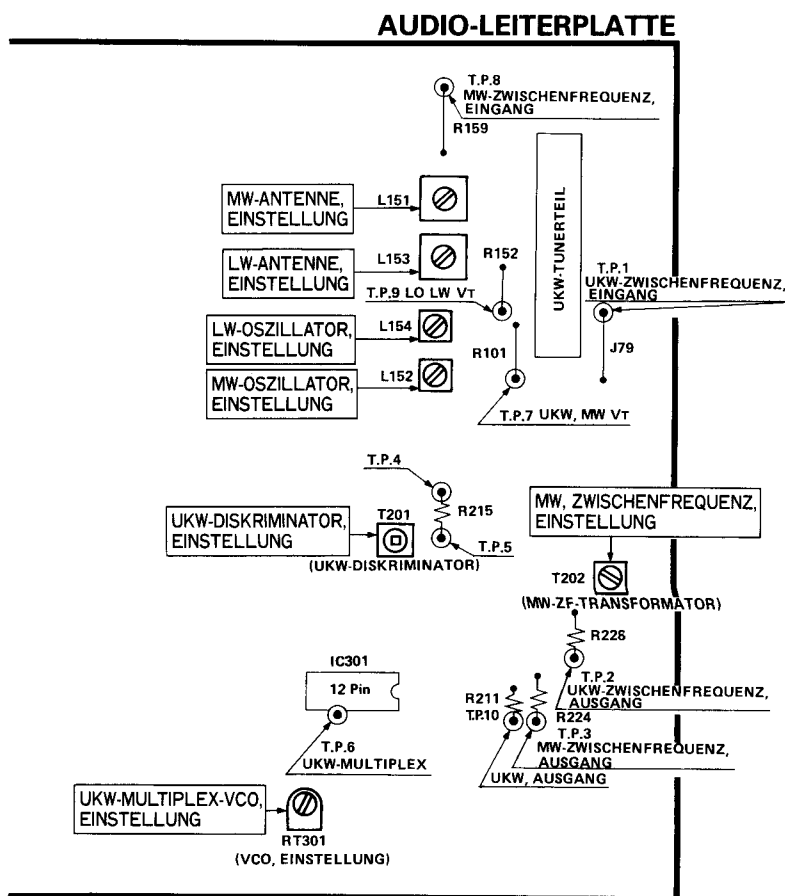
Schritt	Einstellteil	Meßgerät und Meßanschlüsse			Frequenz von Genescope oder Signalgenerator	Skalenanzeige	Einstellung an	Meßwert
		Meßgerät	Eingangsanschluß	Ausgangsanschluß				
1	(1) Diskriminator	• Gleichspannungsausgleichsindikator- (in AUTO Zustand)	UKW-Antenne, 400 Hz, Hub 22,5 kHz, 60 dB	Meßpunkt TP. 4(+) Meßpunkt TP. 5(-)	98 MHz	98 MHz	T201	$0 \pm 10$ mV
2	(1) Multiplex-VCO (19 kHz)	Frequenzzähler	UKW-Antennenanschluß, 75 Ohm, 60 dB, unmoduliert	Meßpunkt TP. 6 (über einen widerstand von 100 k $\Omega$ )	98 MHz	98 MHz	RT301	19 kHz $\pm$ 50 Hz

**Hinweis 1:** Bei schwachem Ausgangssignal des Wobbelgenerators sicherstellen, daß der Sinalpegel Höchstwert annimmt und der Signalverlauf symmetrisch ist (siehe Abb. 11). Den Pegel des Wobbelgenerators anheben und sicherstellen, daß der Frequenzgang an Punkt (A) möglichst linear verläuft (siehe Abb. 12).

**Hinweis 2:** Den Eingangspegel zunächst auf 74 dB/m einstellen und dann zur Fortsetzung der Abgleicharbeiten ggf. auf Mindestwert (ca. 60 dB/m) einstellen. Immer so einstellen, daß bei der angegebenen Frequenz ein maximaler Ausgangspegel anliegt. Da bei diesem Gerät ein Trimmkondensator fehlt, ist keine Nachlaufeinstellung der oberen Grenzfrequenz erforderlich.



Abb. 11



Abb. 12

2. TAPEDECK

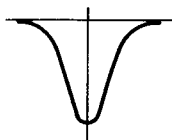
• Einstellpunkte

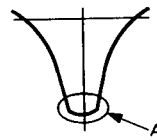

Abb. 13

(1) Einstellung des Kopfazimuts

Betriebsart: Wiedergabe

Anschlüsse:

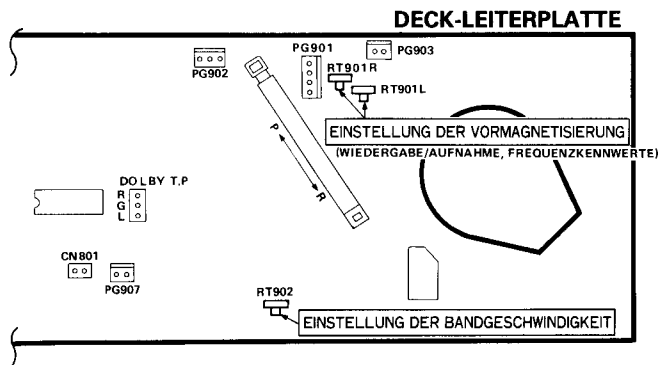
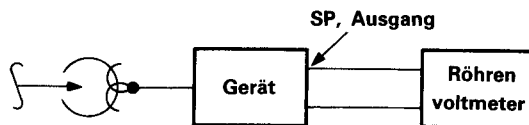

Einstellung:

Das Testband (10 kHz) wiedergeben und mit der Azimut-Einstellschraube auf maximalen Ausgangspegel einstellen. Bei unterschiedlichen Spitzenpegeln auf linkem und rechtem Kanal die Einstellung für den linken Kanal vornehmen. Der Unterschied zwischen den beiden Spitzenpegel darf höchstens 2 dB betragen.

Nach Abschluß der Einstellung die Schraube in ihrer Stellung fixieren.

(2) Einstellung der Frequenzkennwerte (Einstellung der vormagnetisierung)

Betriebsart: Wiedergabe

Anschlüsse:



Abb. 15

Bezugsbezeichnung	Bedien- und Einstellelemente für	Stellung
S903	Rauschunterdrückungssystem DOLBY NR	OFF (Aus)
S902	Bandsortenwahl	NOR (Normal)
RV901	Aufnahmepegel	MAX (Höchstwert)
S991	RIF	A

Tonkopf, Andruckrolle und Tonwelle mit einem mit Alkohol befeuchteten Wattestäbchen reinigen. Anschließend die folgenden Einstellarbeiten in der angegebenen Reihenfolge ausführen.

**Einstellung:** Zunächst RT901L, R in Mittelstellung bringen.

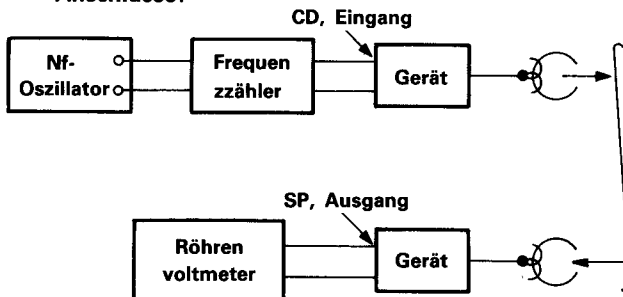
① 400-Hz- und 10-kHz-Signale mit einem Pegel von  $-25$  dB aufzeichnen. Das Gerät auf Aufnahme stellen und bei einer Abweichung von mehr als  $-25$  dB  $\pm$  1,5 dB am Ausgang RT901L, R entsprechend einstellen.

Die Aufnahme/Wiedergabe-Frequenzkennwerte des Testbands bei einem Pegel von  $-25$  dB messen und sicherstellen, daß der Meßwert innerhalb des Toleranzbereichs liegt.

② Ein 300-Hz-Signal zuführen und den Nf-Oszillator so einstellen, daß das Meßgerät  $-10$  dB anzeigt. Anschließend das Signal aufzeichnen. Die Bandaufzeichnung wiedergeben und sicherstellen, daß der Ausgangspegel einen Wert von  $-10$  dB  $\pm$  2 dB hat.

**Hinweis:** Die Prüfungen gelten ausschließlich für Ferrochrom- und Reineisenband.

### (3) Einstellung der Bandgeschwindigkeit

Einstellgegenstand	Einstellpunkt	Verfahren
Einstellung der Bandgeschwindigkeit	RT902	Das Testband (300 Hz) in Laufwerk TAPE 2 wiedergeben und entsprechend einstellen. (Einstellung auf Normalwert) Normalwert $\rightarrow$ $3000 \pm 30$ Hz

Der Geschwindigkeitsunterschied zwischen TAPE 1 und TAPE 2 muß im Bereich von  $+70$  bis  $-40$  Hz liegen.

## PRÜFUNG DES LAUFWERKS

Laufende Nr.	Prüfgegenstand	Bezugswert	Anmerkungen
1	Druck der Andruckrolle	300–500 g	Hinweis
2	Aufwickelmoment	30–60 g·cm	
3	Schnellvorlauf-/Rückspulmoment	50 g·cm oder darüber	
4	Autostopp-Sensor, Betätigungskraft	40–75 g	
5	Bremsmoment	15 g·cm oder darüber	Messung bei Stoppbetrieb
6	Bandspannungsmoment	Aufwickellseite	1–6 g·cm
		Abwickelseite	1–4 g·cm
7	Axialspiel des Schwungrads	0.05–0.5 mm	
8	Betätigungskraft der Tasten	Wiedergabetaste	1,1 kg oder darunter
		Schnellvorlauftaste	0,8 kg oder darunter
		Rücklauftaste	1,1 kg oder darunter
		Auswurfaste	0,6 kg oder darunter
		Aufnahmetaste	1,0 kg oder darunter
		Pausetaste	1,0 kg oder darunter

#### Hinweis:

Das Gerät auf Wiedergabe stellen und die Andruckrolle mit einer Bandspannungslehre (Fächertyp) in Pfeilrichtung drücken; den Druck messen, sobald sich die Andruckrolle von der Tonwelle trennt.

### HT-MD30/HT-MD30X

#### Einstellung der Drehzahl (Abb. 16)

Ist auch nach Austausch des Motors die Drehzahl nicht wie vorgeschrieben, die Stroboskopscheibe verwenden. (Einstellung ohne Ausbau der Bodenplatte möglich.)

**Hinweis:** Zunächst eine Vorwärmzeit des Plattenspieler von über 10 Minuten bei einer Drehzahl von  $33\frac{1}{3}$  min $^{-1}$  abwarten und erst dann mit der Einstellung beginnen.

Die Einstellung in der angegebenen Reihenfolge ausführen:

- (1) Den Plattenspieler auf  $33\frac{1}{3}$  min $^{-1}$  stellen und dann mit **A** den vorgeschriebenen Wert ( $33\frac{1}{3}$  min $^{-1}$ ) einstellen.
- (2) Den Plattenspieler auf  $45$  min $^{-1}$  stellen und dann mit **B** den vorgeschriebenen Wert ( $45$  min $^{-1}$ ) einstellen.



Abb. 16



Abb. 17

# RÉGLAGE

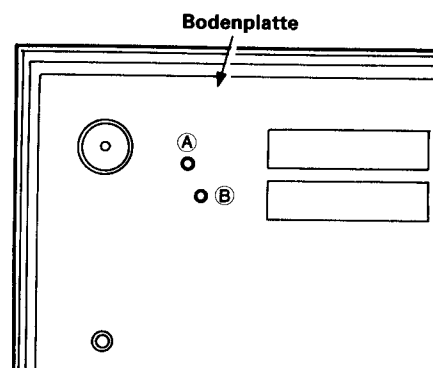
HRD-MD30

## 1. SECTION RADIO

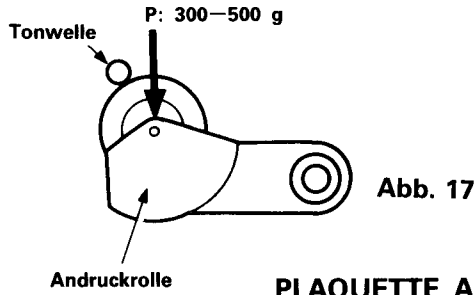
### ● Points de réglage

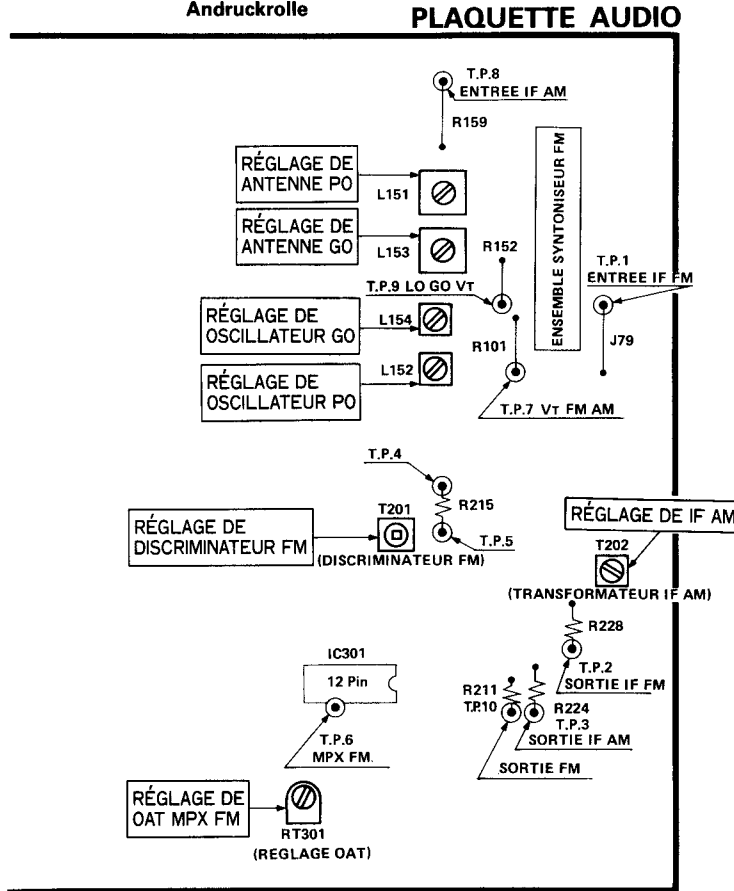

Fig. 10

### Section MA

Etape	Poste de réglage	Instrument de mesure et connexion			Fréquence du gènescope ou du générateur de signaux	Position de l'indicateur du cadran	Réglez	Lecture
		Instrument de mesure	Borne d'entrée	Borne de sortie				
1	(1) AM IF (moyenne fréquence MA)	Gènescope (455 kHz)	TP. 8	TP. 3	450 kHz	Le plus haut possible	T202	Remarque 1
	(2)							
2	(1) MW OSC (oscillateur PO) (guipage)	<ul style="list-style-type: none"> <li>Générateur de signaux MA (400 Hz, 30% de mod.)</li> <li>VTVM (voltmètre électronique)</li> <li>Oscilloscope</li> </ul>	Antenna à boucle Remarque 2	TP. 7	522 kHz (sauf US, CS) 530 kHz (pour US, CS)	Le plus bas possible	L152	1.2 V (sauf US, CS) 1.25 V (pour US, CS)
	(1) MW ANT (antenne PO) (alignement)							
3	(1) MW ANT (antenne PO) (alignement)	<ul style="list-style-type: none"> <li>VTVM (voltmètre électronique)</li> <li>Oscilloscope</li> </ul>	Antenna à boucle Remarque 2	SP. OUT (hors circuit)	600 kHz	600 kHz	L151	Max Remarque 2
4	(1) LW OSC (oscillateur GO) (guipage)	<ul style="list-style-type: none"> <li>Générateur de signaux MA (400 Hz, 30% de mod.)</li> <li>VTVM (voltmètre électronique)</li> <li>Oscilloscope</li> </ul>	Antenna à boucle Remarque 2	TP. 9	153 kHz	Le plus bas possible	L154	1.2 V
	(1) LW ANT (antenne GO) (alignement)							
5	(1) LW ANT (antenne GO) (alignement)	<ul style="list-style-type: none"> <li>VTVM (voltmètre électronique)</li> <li>Oscilloscope</li> </ul>	Antenna à boucle Remarque 2	SP. OUT (hors circuit)	164 kHz	164 kHz	L153	Max Remarque 2

Section MF

Etape	Poste de réglage	Instrument de mesure et connexion			Fréquence du généscope ou du générateur de signaux	Position de l'indicateur du cadran	Réglez	Lecture
		Instrument de mesure	Borne d'entrée	Borne de sortie				
1	(1) Discriminateur	• Indicateur de zéro CC (état AUTO)	FM ANT (antenne MF) 400 Hz 22,5 kHz dév 60 dB	TP. 4 (+) TP. 5 (-)	98 MHz	98 MHz	T201	0 ± 10 mV
2	(1) MPX VCO (oscillateur à fréquence réglée par variation de tension MPX) (19 kHz)	Compteur de fréquences	Borne d'antenne MF 22,5 kHz dév. 60 dB non-modulation	TP. 6 (Connectez par enregistreur 100 kohms)	98 MHz	98 MHz	RT301	19 kHz ± 50 Hz

**Remarque 1:** Si le signal provenant du générateur de balayage est faible, assurez-vous que la forme d'onde devienne maximale et symétrique comme indiqué en fig. 11.

Augmentez le niveau du générateur de balayage et vérifiez que le parcours en point A est aussi plat que possible comme indiqué en fig. 12.

**Remarque 2:** Placez d'abord le niveau d'entrée à 74 dB/m, et abaissez le niveau au minimum comme il vous l'est demandé (environ 60 dB/m) pour continuer le réglage. Réglez à plusieurs reprises jusqu'à ce que la sortie soit maximale à la fréquence spécifiée.

Comme le condensateur variable a été éliminé, il n'est pas nécessaire de procéder au réglage de poursuite de la fréquence de limite supérieure.

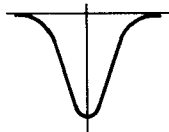

Fig. 11

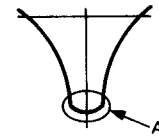

Fig. 12

2. SECTION MAGNETOCASSETTE

● Points de réglage

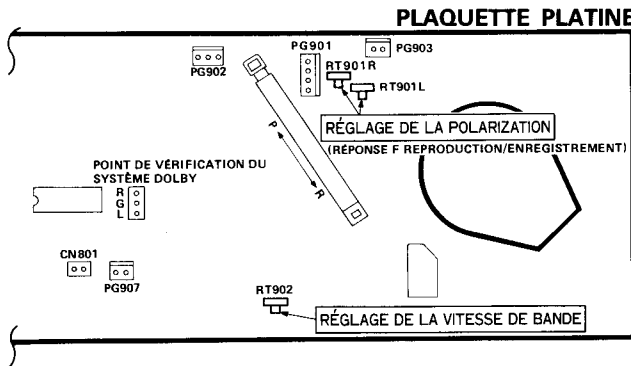

Fig. 13

Neméro de symbole	Commutateurs et commandes	Position
S903	DOLBY NR	OFF (hors circuit)
S902	TAPE SELECT SW (sélecteur de bande)	NOR
RV901	REC VOL (volume de l'enregistrement)	MAX
S991	RIF SW (Commutateur RIF)	A

Effectuez les réglages suivants dans l'ordre spécifié après nettoyage de la tête, du galet-presseur et du cabestan à l'aide d'un coton-tige imbibé d'alcool.

(1) Réglage de l'azimuth de tête

Mise au point: mode de reproduction

Connexion: SP OUT (hors circuit)

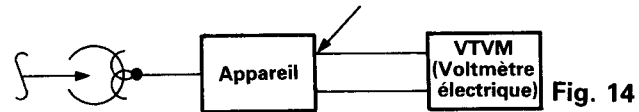

Fig. 14

Réglage:

Reproduisez la bande d'essai (10 kHz) et réglez la vis de réglage azimuthal pour obtenir une sortie maximale, néanmoins, si le niveau de crête diffère entre le canal gauche et le canal droit, réglez-le au niveau de crête du canal gauche. A ce moment, la différence entre les deux niveaux de crête des canaux devrait être d'un ordre de 2 dB.

Après réglage, vissez la vis.

(2) Réglage caractéristique des fréquences (réglage de la polarization)

Mise au point: mode d'enregistrement/reproduction

Connexion: CD INPUT (entrée CD)

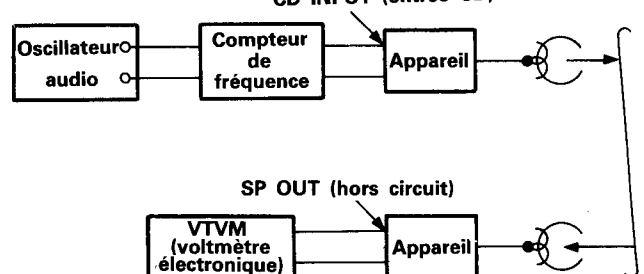

Fig. 15

**Réglage:** Au préalable, positionner RT901LR au centre.

- Enregistrez des signaux de 400 Hz et 10 kHz à un niveau de -25 dB. Placez en mode d'enregistrement, et si vous obtenez une différence de plus de  $-25 \text{ dB} \pm 1,5 \text{ dB}$  à la sortie, réglez RT901L, R.

Mesurez la fréquence d'enregistrement/reproduction caractéristique de la bande d'essai au niveau de -25 dB. Puis vérifiez que la valeur mesurée est comprise dans la gamme de spécification.

- Appliquer un signal de 400 Hz et régler l'oscillateur audio jusqu'à ce que le compteur indique -10 dB, puis enregistrer sur la bande. Reproduire la bande enregistrée et vérifier que le niveau de sortie soit de  $-10 \text{ dB} \pm 2 \text{ dB}$ .

**Remarque:** Pour les bandes au chrome et au métal, ne faire que des vérifications.

### (3) Réglage de la vitesse de bande

Point	Réglez	Mise au point
Réglage de la vitesse bande	RT902	Reproduisez la bande d'essai (3000 Hz) sur TAPE 2 pour effectuer le réglage (réglez en position NOR). NOR (vitesse normale) → $3000 \pm 30 \text{ Hz}$

Le différence de vitesse entre TAPE 1 et TAPE 2 doit être dans  $\pm 70$  à  $-40 \text{ Hz}$ .

### HT-MD30/HT-MD30X

#### Réglage de la vitesse (Fig. 16)

Si la vitesse prévue ne peut être obtenue après avoir remplacé le moteur, utiliser le disque stroboscopique. (Réglage est possible sans enlever la plaque de fond.)

**Remarque:** Avant le réglage, effectuer un préchauffage au moins 10 minutes la table tournante étant à  $33\text{-}1/3 \text{ tr/mn}$ . Procéder à ce réglage dans l'ordre de (1) et (2).

- Mettre la vitesse sur  $33\text{-}1/3 \text{ tr/mn}$  et régler (A) de manière à obtenir la vitesse nominale ( $33\text{-}1/3 \text{ tr/mn}$ ).
- Mettre la vitesse sur  $45 \text{ tr/mn}$  et régler (B) de manière à obtenir la vitesse nominale ( $45 \text{ tr/mn}$ ).

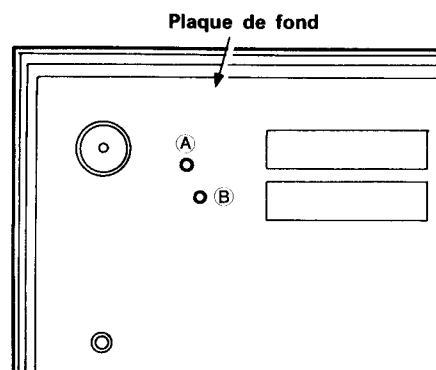

Fig. 16

## INSPECTION DU MECANISME

Point	Poste de vérification		Valeur de référence	Remarques
1	Pression du galet-presseur		300-500 g	Remarque
2	Couple d'enroulage		30-60 g·cm	
3	Couple d'avancée rapide/rembobinage rapide		50 g·cm ou plus	
4	Effort à l'utilisation du détecteur pour arrêt automatique		40-75 g	
5	Couple de freinage		15 g·cm ou plus	Mesuré en mode d'arrêt
6	Couple de tension de recul	Enroulage	1-6 g·cm	
		Alimentation	1-4 g·cm	
7	Intervalle de poussée du volant		0,05-0,5 mm	
8	Effort à l'utilisation des touches	Touche de reproduction	1,1 kg ou moins	
		Touche d'avancée rapide	0,8 kg ou moins	
		Touche de rembobinage	1,1 kg ou moins	
		Touche d'éjection	0,6 kg ou moins	
		Touche d'enregistrement	1,0 kg ou moins	
		Touche de pause	1,0 kg ou moins	

**Remarque:**

Placez cet appareil en mode de reproduction, appuyez sur le galet-presseur dans le sens de la flèche à l'aide d'un calibre de tension type éventail, et mesurez la pression lorsque le galet-presseur est libéré du cabestan.



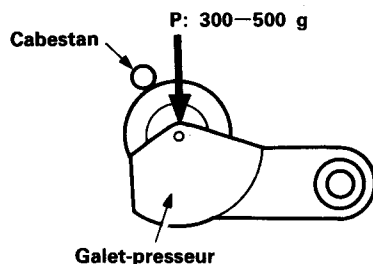

Fig. 17

## LUBRICATION

Apply one or two drops of pan motor oil or sonic slider oil to rotating parts. Coat sliding parts with Molycoat (EL-10M). Lubricate once a year or every 1,000 hours of operation. Do not let oil contact belts or idlers.

Rotating parts	Metal to metal	Pan motor oil (10W-40)
	Plastics to metal	Sonic slider oil (#1600)
Sliding parts	(Note) Plastics to plastics	Molycoat (EL-10M)
	Plastics to metal	
Spring vibration prevention		Floyl (GB-TS-1)

### NOTE:

When front frame and slide knob are replaced, coat both contacting parts lightly with white grease.

## SCHMIERUNG

An die drehenden Teilen ein oder zwei Tropfen Motoröl oder Schmieröl (Sonic Slider) geben, und die Gleitteile mit Molycoat (EL-10M) schmieren.

Einmal im Jahr oder alle 1,000 Betriebsstunden schmieren. Darauf achten, da das Öl nicht auf den Riemen oder die Zwischenscheiben gelangt.

Drehende Teile	Zwischen Metallteilen	Motoröl (10W-40)
	Zwischen Plastik und Metall	Schmieröl (Sonic Slider #1600)
Gleitteile	(Hinweis) Zwischen Plastikteilen	Molycoat (EL-10M)
	Zwischen Plastik und Metall	
Verhinderung von Federvibrationen		Floyl (GB-TS-1)

### Hinweis:

Wenn der Frontrahmen und Schieberegler ersetzt werden, beide Kontaktflächen leicht mit weißem Schmierfett überziehen.

## LUBRIFICATION

Appliquer une ou deux gouttes d'huile moteur ou d'huile Sonic pour curseur, sur les membres rotatifs. De la graisse Molycoat (EL-10M) est appliquée sur les membres coulissants.

Lubrifier une fois par an ou toutes les 1,000 heures de fonctionnement.

Veiller à ne pas appliquer d'huile sur les courroies ou les galets.

Membres rotatifs	Entre les parties métalliques	Huile moteur (10W-40)
	Entre le moulage et les parties métalliques	Huile Sonic pour curseur (#1600)
Membres coulissants	(Remarque) Entre moulures	Molycoat (EL-10M)
	Entre moulures et pièces métalliques	
Prévention de vibration de ressort		Floyl (GB-TS-1)

### Remarque:

Lorsque le châssis avant et le boulon curseur doivent être remplacés, appliquer une couche légère de graisse blanche sur les parties de contact.

## MAINTENANCE

### ■ Clean cabinet and panels when dirty

Clean off dirt on the surfaces with a dry cloth. Never use thinners, benzene or alcohol since these will damage the surface finish.

## ENTRETIEN

### ■ Nettoyage du coffret et des panneaux lorsqu'ils sont sales

Enlever la poussière des surfaces de l'appareil avec un chiffon sec. Ne jamais utiliser de solvants, de benzine ou d'alcool car ils abîmeraient le fini des surfaces.

Check that exposed parts are acceptably insulated from the supply circuit before returning the instrument repaired to the customer.

#### ● Checking method

Operate switch is set to ON.

Next, measure the resistance value between the both poles of attachment cup (Power supply plug) and the exposed parts (Parts such as Knob, Cover, etc. where the customer is easy to touch.) and check that the resistance value is 500 kohms or more.

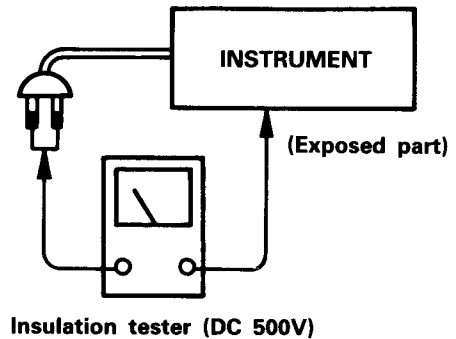

## PFLEGE DES GERÄTS

### ■ Reinigung des Gehäuses und der Oberflächen

Die Geräteoberflächen mit einem trockenen Tuch reinigen. Keinesfalls Verdüner, Waschbenzin oder Alkohol verwenden, da durch diese scharfen Mittel die Oberflächenbeschichtung angegriffen wird.

## DIFFERENCE FOR DESTINATION [for DISPLAY/DECK P.W.B.] UNTERSCHIEDE NACH BESTIMMUNGSLÄNDERN [für DISPLAY/DECK-LEITERPLATTE]

## DIFFÉRENCE EN FONCTION DU PAYS DE DESTINATION [pour PLAQUETTE D'AFFICHAGE/PLATINE]

☆SYMBOL NO.	US, CS	ES	ZS	EW	SA	BS
C504 ~ C506	—	USE	—	—	—	USE
C665	—	—	USE	—	—	—
C666, C667	—	USE	—	—	—	USE
C989, 993	—	USE	—	—	—	USE
R505 ~ 508	—	USE	—	—	—	USE
R521, R561 ~ 563	—	—	—	USE	—	—
R996, 997	—	USE	—	—	—	USE
Q503, 504	—	USE	—	—	—	USE
Q508, 509	—	—	—	USE	—	—
Q992	—	USE	—	—	—	USE
D512	—	USE	USE	USE	—	USE
D514	—	USE	USE	USE	USE	USE
S515	—	USE	—	—	—	USE
CN202	8P	8P	8P	9P	8P	8P
CN991	—	USE	—	—	—	USE
J277	—	USE	USE	—	USE	USE
J246, 248, 251	USE	—	USE	USE	USE	—
J247, 249, 250	—	USE	—	—	—	USE
J254	—	USE	USE	USE	—	USE
J255	USE	—	—	—	USE	—
J260	—	USE	—	—	—	USE
J278, 286	—	—	—	USE	—	—

**DIFFERENCE FOR DESTINATION [for AUDIO P.W.B.]**  
**UNTERSCHIEDE NACH BESTIMMUNGSLÄNDERN**  
**[für AUDIO LEITERPLATTE]**  
**DIFFÉRENCE EN FONCTION DU PAYS DE DESTINATION**  
**[pour PLAQUETTE AUDIO]**

☆SYMBOL NO.	US, CS	ES	ZS	EW	SA	BS
C102	—	—	USE	—	—	—
C103	—	—	USE	—	—	—
C104	—	—	USE	—	—	—
C105	—	—	USE	—	—	—
C106	—	—	USE	—	—	—
C108	—	USE	USE	—	USE	USE
C112	—	—	USE	—	—	—
C154	—	USE	—	—	—	USE
C156	—	USE	—	—	—	USE
C157	—	USE	—	—	—	USE
C158	—	USE	—	—	—	USE
C159	—	USE	—	—	—	USE
C161	—	USE	—	—	—	USE
C315	—	—	USE	—	—	—
C320	—	—	USE	—	—	—
C401LR	—	—	USE	—	—	—
C404LR	USE	USE	USE	USE	USE	—
C405LR	USE	USE	USE	USE	USE	—
C410LR	—	—	USE	—	—	—
C416	—	—	USE	—	—	—
C418	—	—	USE	—	—	—
C419	—	—	USE	—	—	—
C420	—	—	USE	—	—	—
C702LR	USE	USE	—	USE	USE	USE
C711LR	—	—	USE	—	—	—
C712LR	—	—	USE	—	—	—
C713	USE	USE	USE	USE	USE	—
C714	—	—	USE	—	—	—
C715LR	—	—	USE	—	—	—
C811	—	—	USE	—	—	—
C812	—	—	USE	—	—	—
R001	USE	—	—	—	—	—
R103	—	—	USE	—	—	—
R104	—	—	USE	—	—	—
R105	—	—	USE	—	—	—
R106	—	—	USE	—	—	—
R107	—	—	USE	—	—	—
R109	—	—	USE	—	—	—
R201	USE	USE	—	USE	USE	USE
R152	—	USE	—	—	—	USE
R153	—	USE	—	—	—	USE
R155	—	USE	—	—	—	USE
R156	—	USE	—	—	—	USE
R157	—	USE	—	—	—	USE
R158	—	USE	—	—	—	USE
R315	—	—	USE	—	—	—
R405LR	USE	USE	USE	USE	USE	—
R406LR	USE	USE	USE	USE	USE	—
R543	—	USE	—	—	—	USE
R544, 545	—	USE	—	—	—	USE
R809	USE	USE	USE	USE	USE	—

☆SYMBOL NO.	US, CS	ES	ZS	EW	SA	BS
R810	USE	USE	USE	USE	USE	—
Q101	—	—	USE	—	—	—
Q102	—	—	USE	—	—	—
Q151	—	USE	—	—	—	USE
PG202	8pins	8pins	8pins	9pins	8pins	8pins
Q152	—	USE	—	—	—	USE
Q514	—	USE	—	—	—	USE
Q515	—	USE	—	—	—	USE
D103	—	—	USE	—	—	—
D104	—	—	USE	—	—	—
D154	—	USE	—	—	—	USE
D155	—	USE	—	—	—	USE
D156	—	USE	—	—	—	USE
D157	—	USE	—	—	—	USE
D158	—	USE	—	—	—	USE
D159	—	USE	—	—	—	USE
L153	—	USE	—	—	—	USE
L154	—	USE	—	—	—	USE
T11	—	USE	—	—	—	USE
T12	—	—	USE	—	—	—
T14	USE	USE	USE	USE	USE	—
T15	—	—	USE	—	—	—
T16	—	—	—	USE	—	—
T17	—	—	USE	—	—	—
MF202	—	—	USE	—	—	—
CP101	—	—	USE	—	—	—
CP301	—	—	USE	—	—	—
J54	USE	USE	—	USE	USE	USE
J106	—	USE	—	—	—	USE
J107	USE	—	USE	USE	USE	—
J113	USE	—	USE	USE	USE	—
J114	—	USE	—	—	—	USE
J115	USE	—	USE	USE	USE	—
J116	—	USE	—	—	—	USE
J110	USE	—	USE	USE	USE	—
J131	USE	—	—	—	—	—
J132	—	—	—	—	—	USE
J133	—	—	—	—	—	USE
J138	—	—	—	—	—	USE
J139	—	—	—	—	—	USE
J151	—	—	USE	—	—	—
J152	—	—	—	USE	—	—
J153	USE	USE	—	USE	USE	USE
J154	USE	USE	—	USE	USE	USE
J156	—	—	USE	—	—	—
J157	—	—	USE	—	—	—
WIRE (BROWN)	—	—	—	USE	—	—
WIRE (ORANGE)	—	—	—	USE	—	—
WIRE (BLUE)	—	—	—	USE	—	—
WIRE (GRAY)	—	—	—	USE	—	—
WIRE (WHITE)	—	—	—	USE	—	—
US PIN CORD	—	—	USE	—	—	—
S519	—	—	—	USE	—	—
S991	—	USE	—	—	—	USE
PG101	—	USE	—	USE	USE	USE

# CIRCUIT DIAGRAM · SCHALTPLAN · PLAN DE CIRCUIT

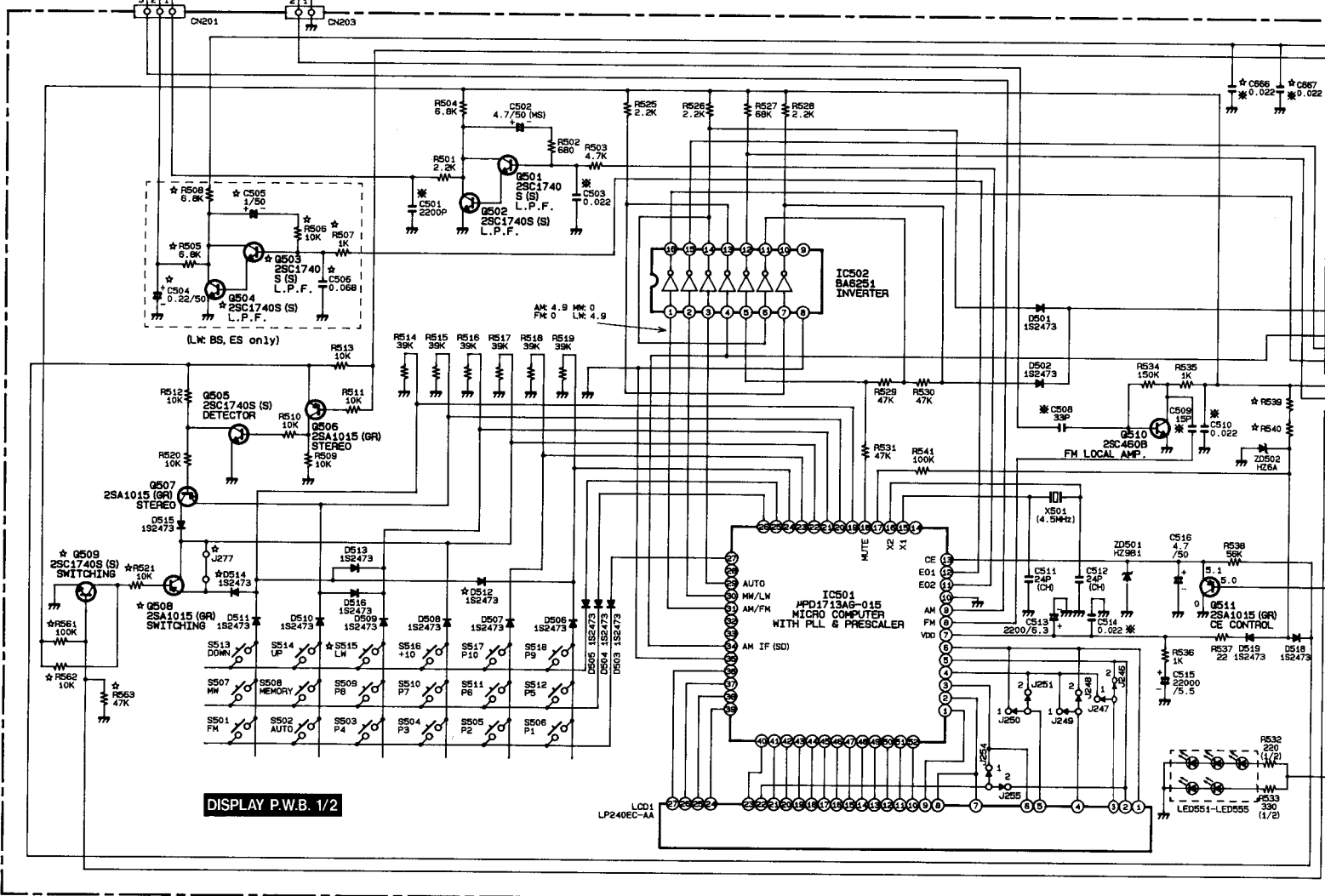
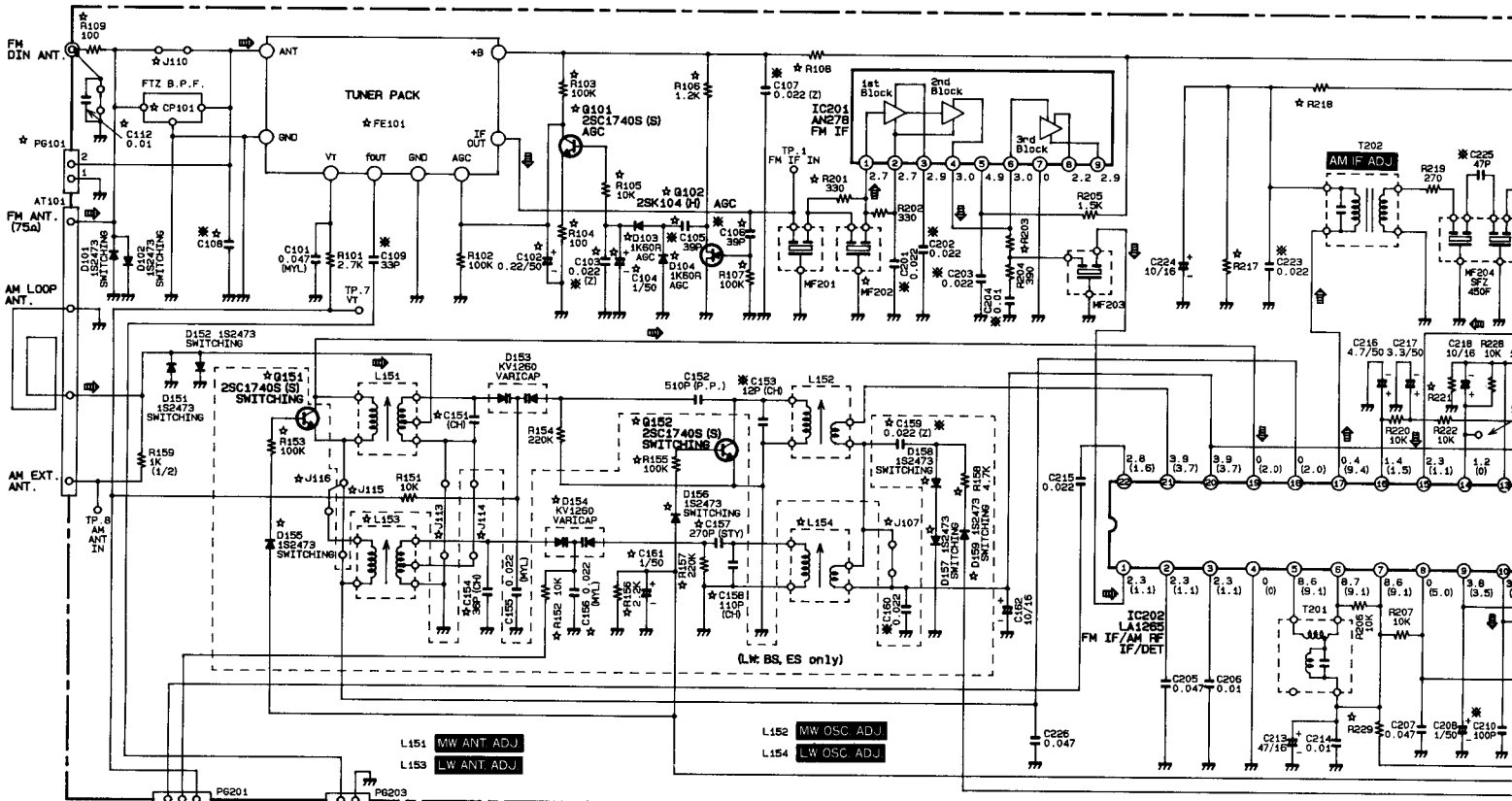

DISPLAY P.W.B. 1/2

LC01 LP240EC-AA

※ : Axial lead cylindrical ceramic capacitor  
 ※ : Zylindrischer Keramik Kondensator mit axialer Zuleitung  
 ※ : Condensateur céramique cylindrique à conducteur axial

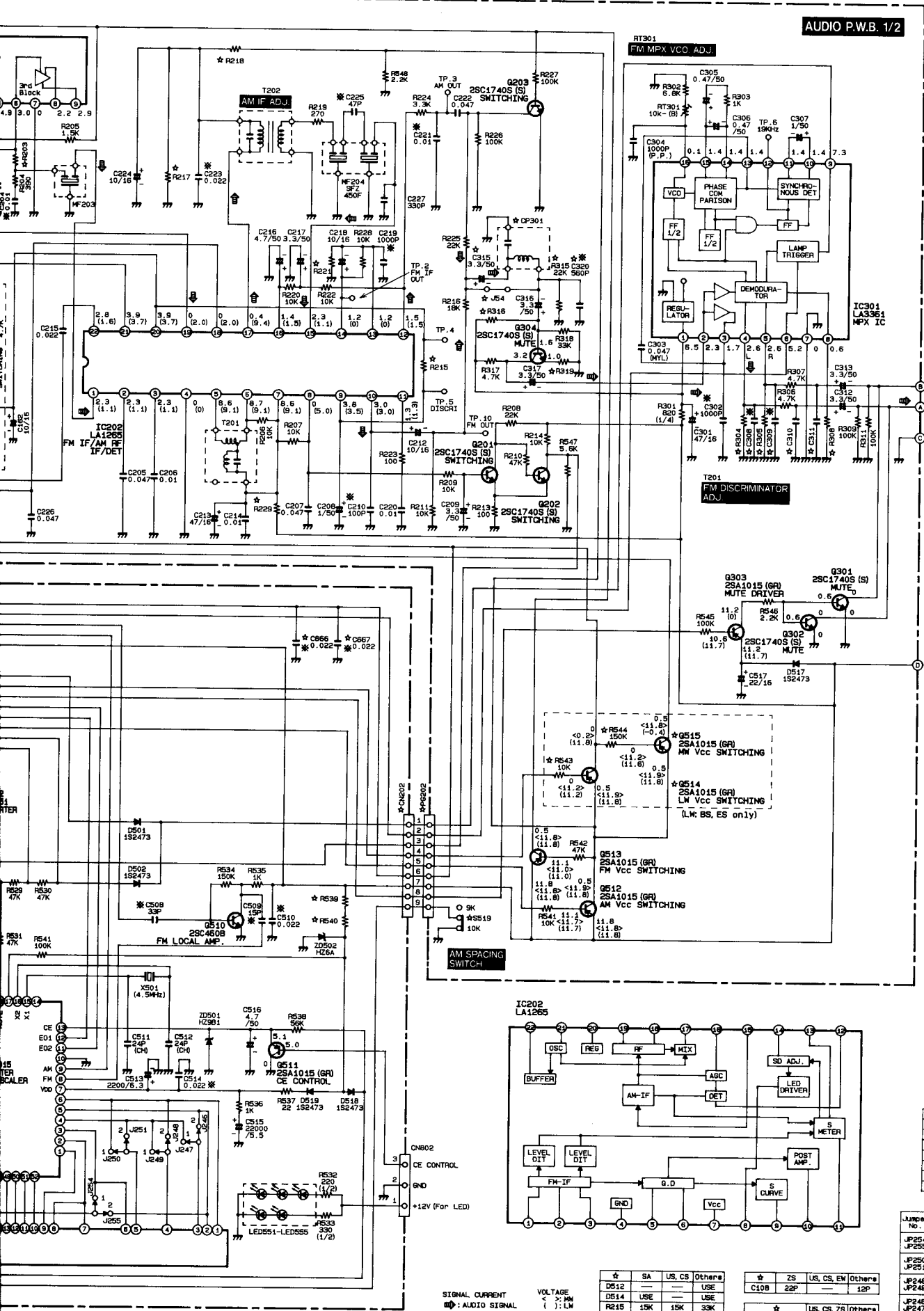

☆	ZS	Others
Q101	USE	---
Q102	USE	---
D103	USE	---
D104	USE	---
R103	USE	---
R104	USE	---
R105	USE	---
R106	USE	---
R107	USE	---
R109	100	---
R201	---	USE
R203	1K	2.2K
R221	0.2K	6.8K
R304	6.8K	5.6K
R305	6.8K	5.6K
R315	USE	---
R316	100K	120K
R319	800	1K
C102	USE	---
C103	USE	---
C104	USE	---
C105	USE	---
C106	USE	---
C112	USE	Jumper
C315	USE	---
C320	USE	---
CP101	USE	---
CP301	USE	---
MF202	USE	---
FE101	47000	30000
J54	---	USE
J110	---	USE

(LW, BS, ES only)

☆	LW	Others
Q151	USE	---
Q152	USE	---
Q503	USE	---
Q504	USE	---
Q514	USE	---
Q515	USE	---
D154	USE	---
D155	USE	---
D156	USE	---
D157	USE	---
D158	USE	---
D159	USE	---
R152	USE	---
R153	USE	---
R155	USE	---
R156	USE	---
R157	USE	---
R158	USE	---
R505	USE	---
R506	USE	---
R507	USE	---
R508	USE	---
R543	USE	---
R544	USE	---
C151	0.1	0.01
C154	USE	---
C156	USE	---
C157	USE	---
C158	USE	---
C159	USE	---
C161	USE	---
C504	USE	---
C505	USE	---
C506	USE	---
C666	USE	---
C667	USE	---
L153	USE	---
L154	USE	---
J115	USE	---
J118	USE	---
J113	USE	---
J114	USE	---
J107	USE	---
Q515	USE	---

☆	EW	Others
Q508	USE	---
Q509	USE	---
R521	USE	---
R561	USE	---
R562	USE	---
R563	USE	---
S519	USE	---
CN202	9P	8P
P6202	9P	8P
J27	USE	---

☆	ZS	US, CS	Others
C308	5600P	0.01	8200P
C309	5600P	0.01	8200P
C310	2200P	4700P	2200P
C311	2200P	4700P	2200P
R308	820	470	390

☆	BS	ZS	Others
R108	68	68	150
R217	68K	56K	56K
R218	5.6K	12K	12K
R220	150 (1)	220 (1)	220 (1)
R301	470 (1/4)	100 (1/2)	820 (1/4)
R330	150 (1/4)	100 (1/2)	100 (1/2)
R540	150 (1/4)	100 (1/2)	100 (1/2)

Jumper No.	Function	BS, ES	EW, ZS	US, CS, SA
JP254	FM channel 1	JP254	JP254	JP255
JP250	AM indication	JP250	JP251	JP251
JP248	FM indication	JP249	JP248	JP248
JP246	LW indication	JP247	JP246	JP246

☆	SA	US, CS	Others
D512	---	---	USE
D514	USE	---	---
R215	15K	15K	33K

☆	ZS	US, CS, EW	Others
C108	22P	---	12P

☆	US, CS, ZS	Others
P6101	---	USE

SIGNAL CURRENT  
 Ⓜ : AUDIO SIGNAL

VOLTAGE  
 < > : LW  
 ( ) : LW

# CIRCUIT DIAGRAM · SCHALTPLAN · PLAN DE CIRCUIT

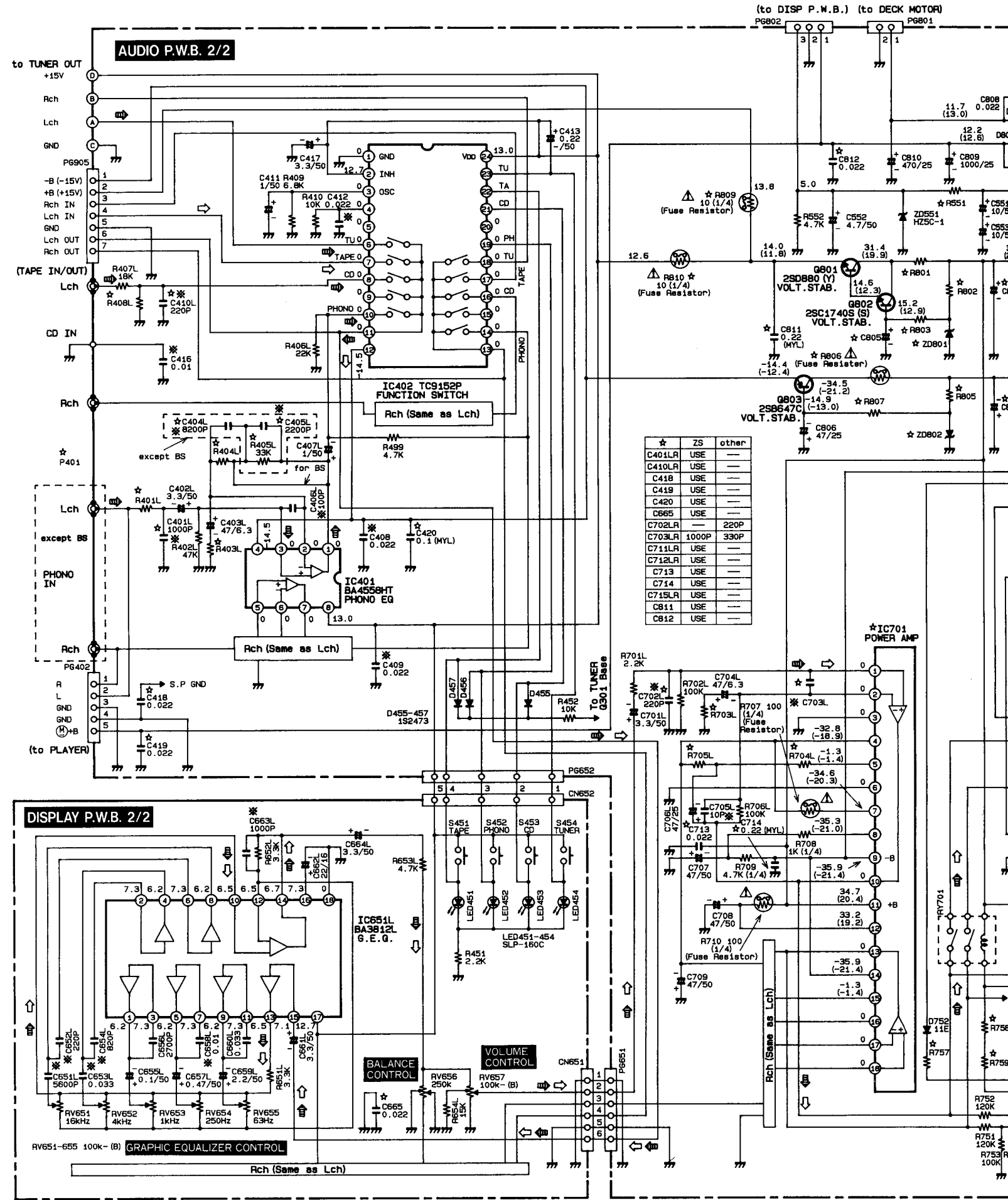

※ : Axiallead cylindrical ceramic capacitor.  
 ※ : Zylindrischer Keramik Kondensator mit axialer Zuleitung.  
 ※ : Condensateur céramique cylindrique à conducteur axial.

MD

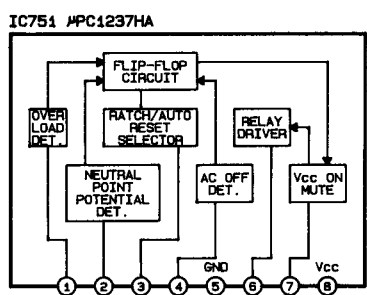
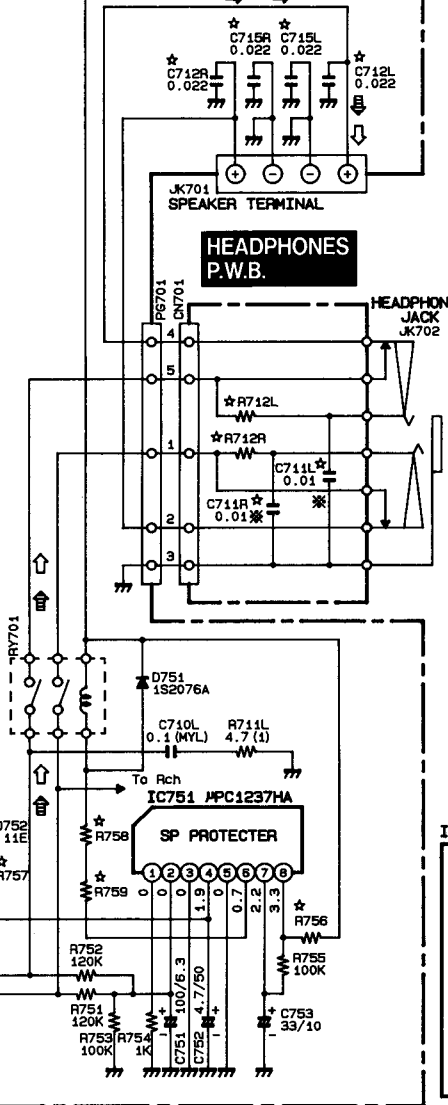
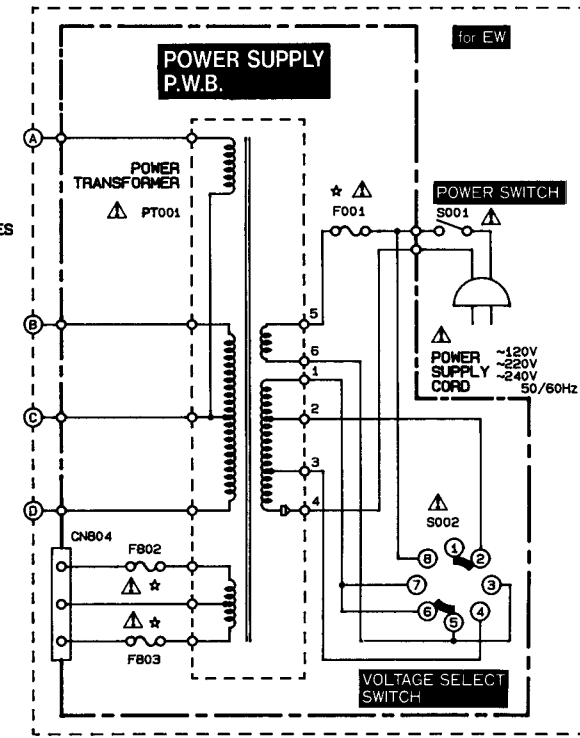
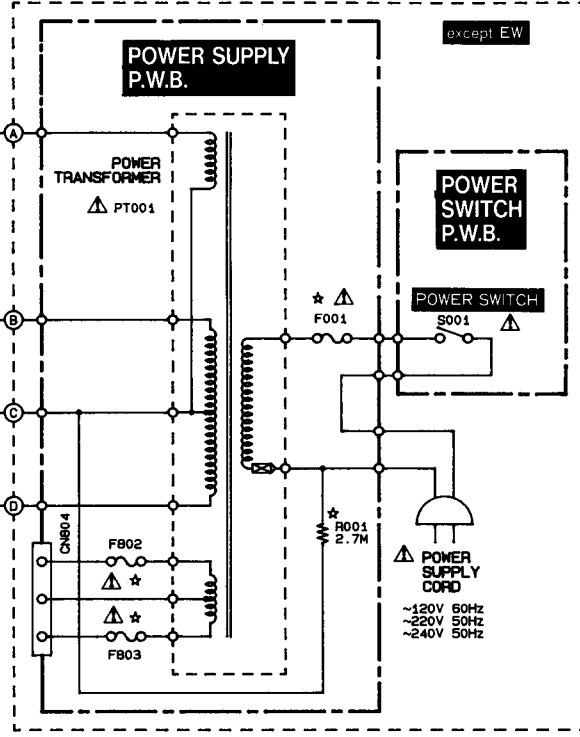
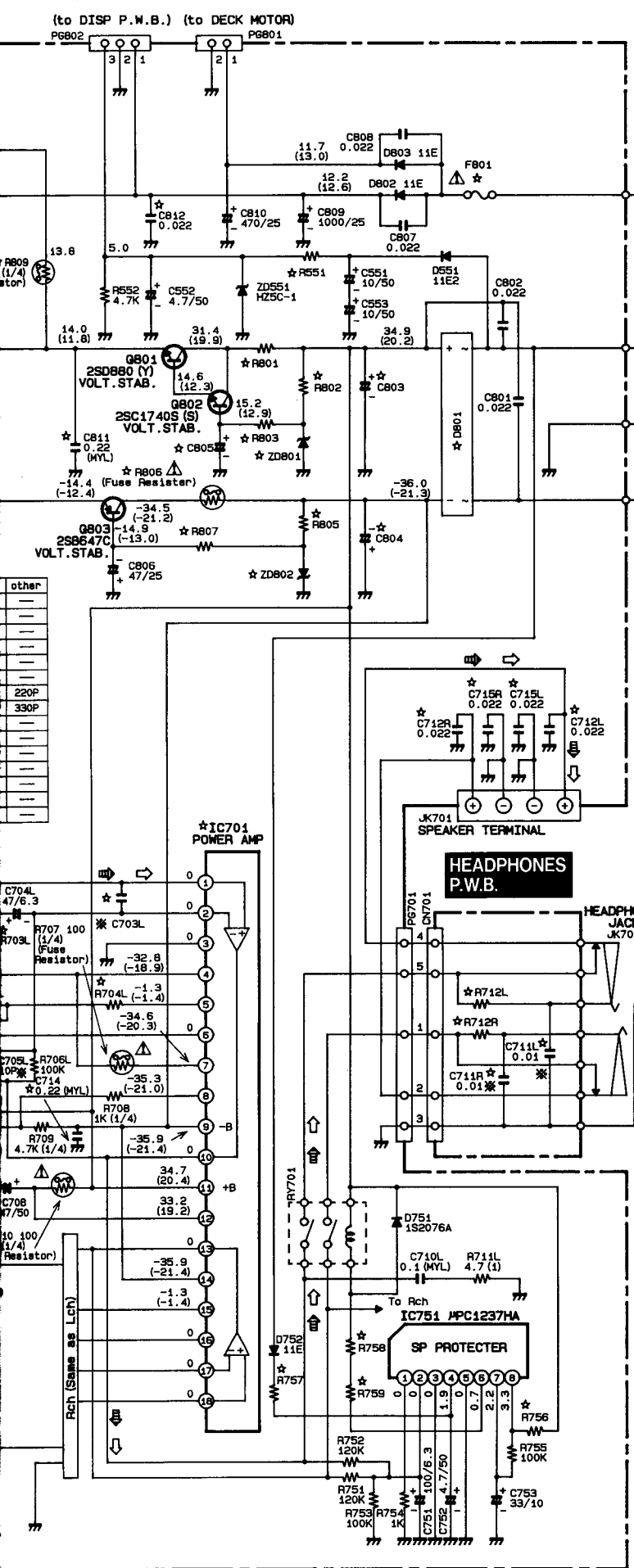

☆	US, CS	BS	Other
F001	2.5A	T400MA	T1A
F801	125V	250V	250V
F802	2A	T2A	T2A
F803	125V	250V	250V

SIGNAL CURRENT  
 □ : PLAY BACK SIGNAL  
 ▢ : AUDIO SIGNAL

VOLTAGE ( ) : For BS

☆	BS	Other
C404LR	—	8200P
C405LR	—	2200P
C803	2200/25	4700/40
C804	2200/25	4700/40
C805	220/25	47/25
R401LR	820K	2.2K
R403LR	2.7K	1.8K
R404LR	18K	390K
R405LR	—	33K
R408LR	82K	22K
R551	2.2K	3.3K
R703LR	820	390
R704LR	2.2K (1/4)	2.7K (1/4)
R705LR	2.2K (1/4)	2.7K (1/4)
R712LR	330 (1)	330 (2)
R756	4.7K (1/4)	10K (1/4)
R757	6.8K	22K
R758	Jumper	270 (1)
R759	Jumper	270 (1)
R801	3.3 (1/2 Fuse)	22 (2)
R802	680 (1/4)	4.7K (1/4)
R803	3.3K (1/4)	1K (1/4)
R805	680 (1/4)	4.7K (1/4)
R806	10 (1/4 Fuse)	220 (1/4 Fuse)
R807	470 (1/4)	1K (1/4)
R809	Jumper	10 (1/4 Fuse)
R810	Jumper	10 (1/4 Fuse)
D801	S2VB20	S4VB20
ZD801	HZ12-B1	HZ-15-3
ZD802	HZ12-B1	HZ-15-3
P401	2P	4P
IC701	STK-4112II	STK-4142II



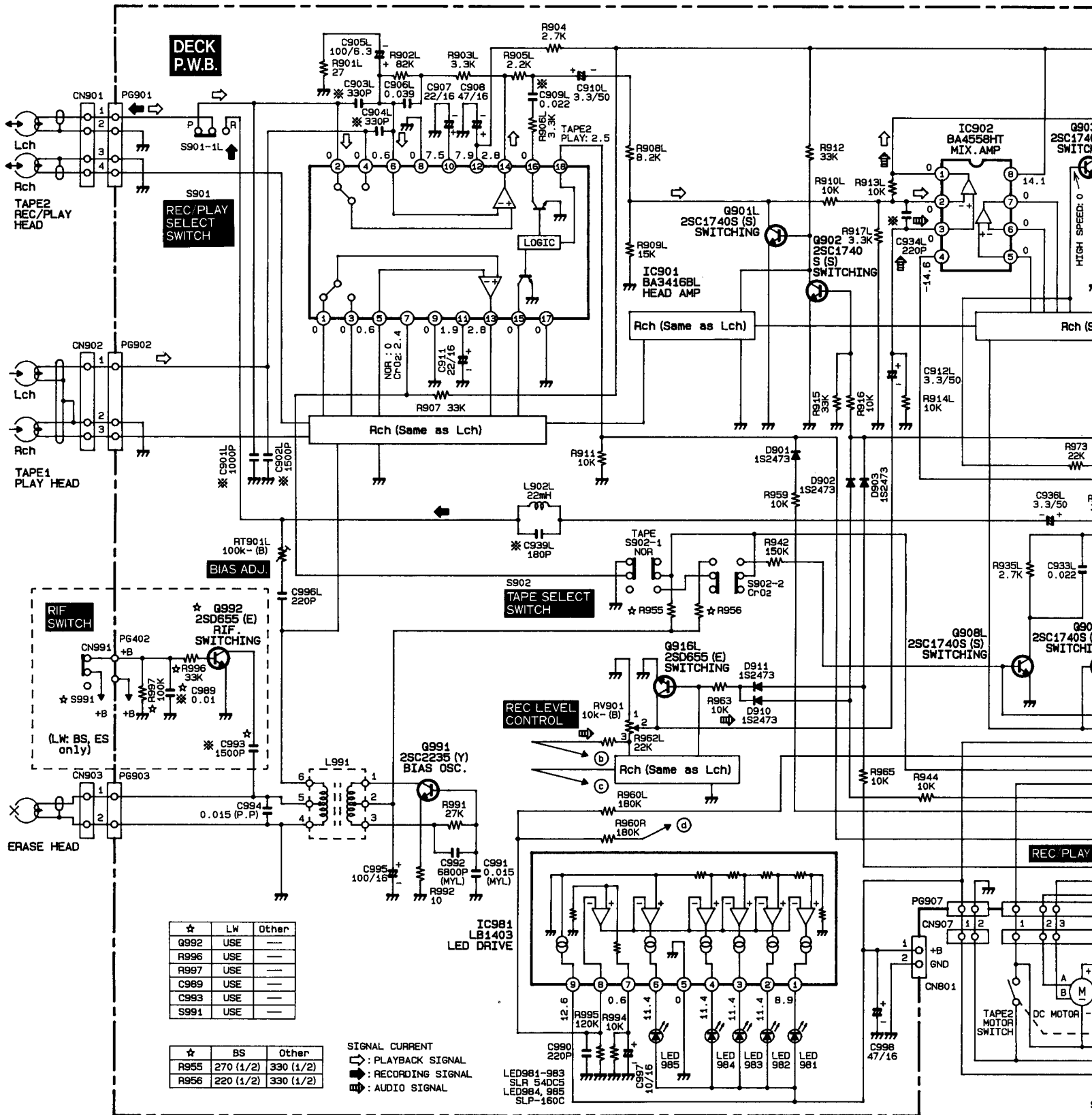

☆	LW	Other
Q992	USE	---
R996	USE	---
R997	USE	---
C989	USE	---
C993	USE	---
S991	USE	---

☆	BS	Other
R955	270 (1/2)	330 (1/2)
R956	220 (1/2)	330 (1/2)

SIGNAL CURRENT  
 ◀: PLAYBACK SIGNAL  
 ▶: RECORDING SIGNAL  
 ⬇: AUDIO SIGNAL

LED981-983  
 SLR 54DC5  
 LED984, 985  
 SLP-160C

- \* : Axial lead cylindrical ceramic capacitor.
- \* : Zylindrischer Keramik Kondensator mit axialer Zuleitung.
- \* : Condensateur céramique cylindrique à conducteur axial.

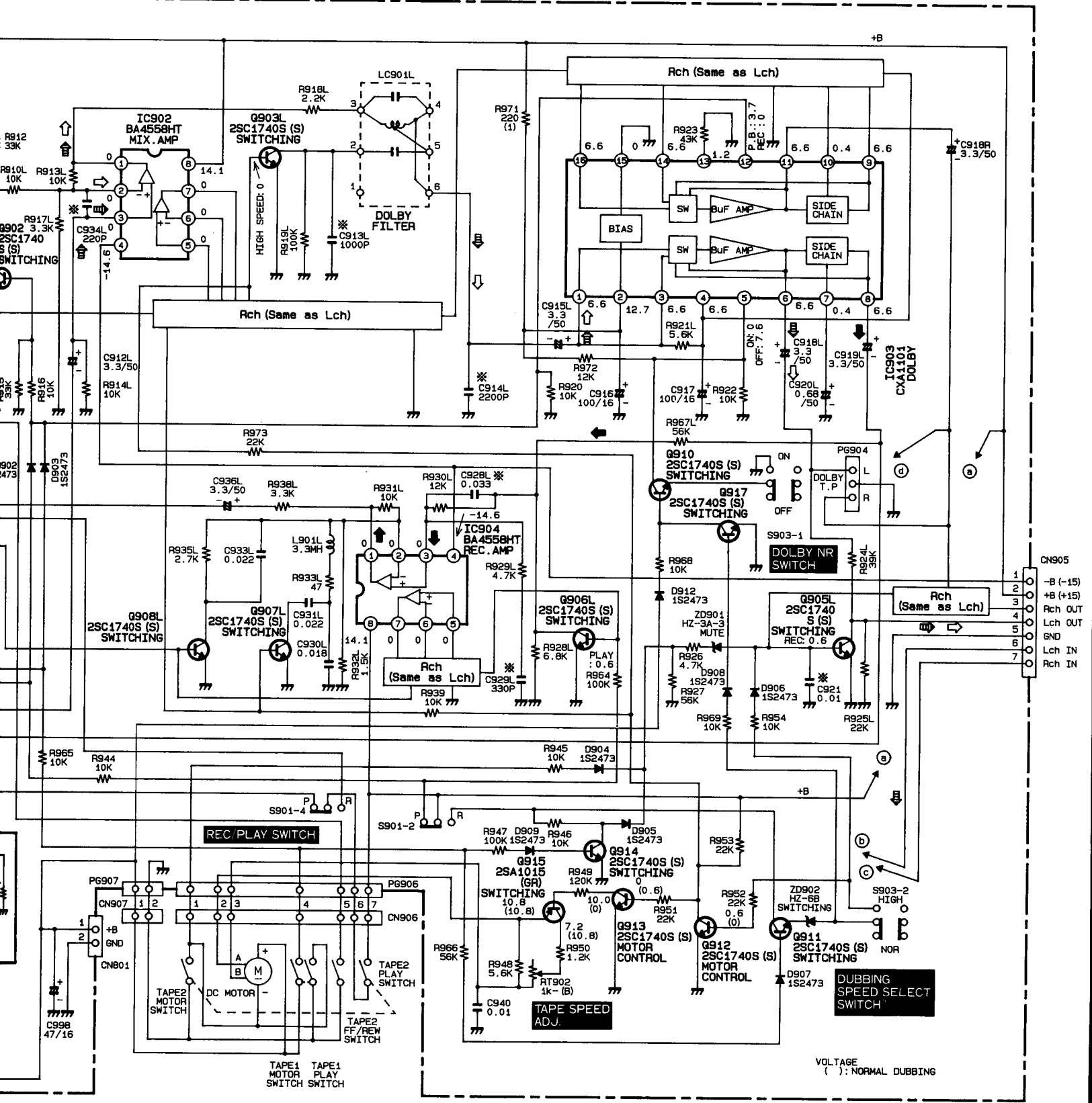

# PRINTED WIRING BOARD PRINTPLATTEN PLAN DE BASE

- ※ : Axial lead cylindrical ceramic capacitor.
- ※ : Zylindrischer Keramikcondensator mit axialer Zuleitung.
- ※ : Condensateur céramique clindrique à conducteur axial.

The circuit symbol (☆) means  
Das Schaltkreissymbol (☆) w  
Le symbol de circuit (☆) sign

## AUDIO P.W.B.

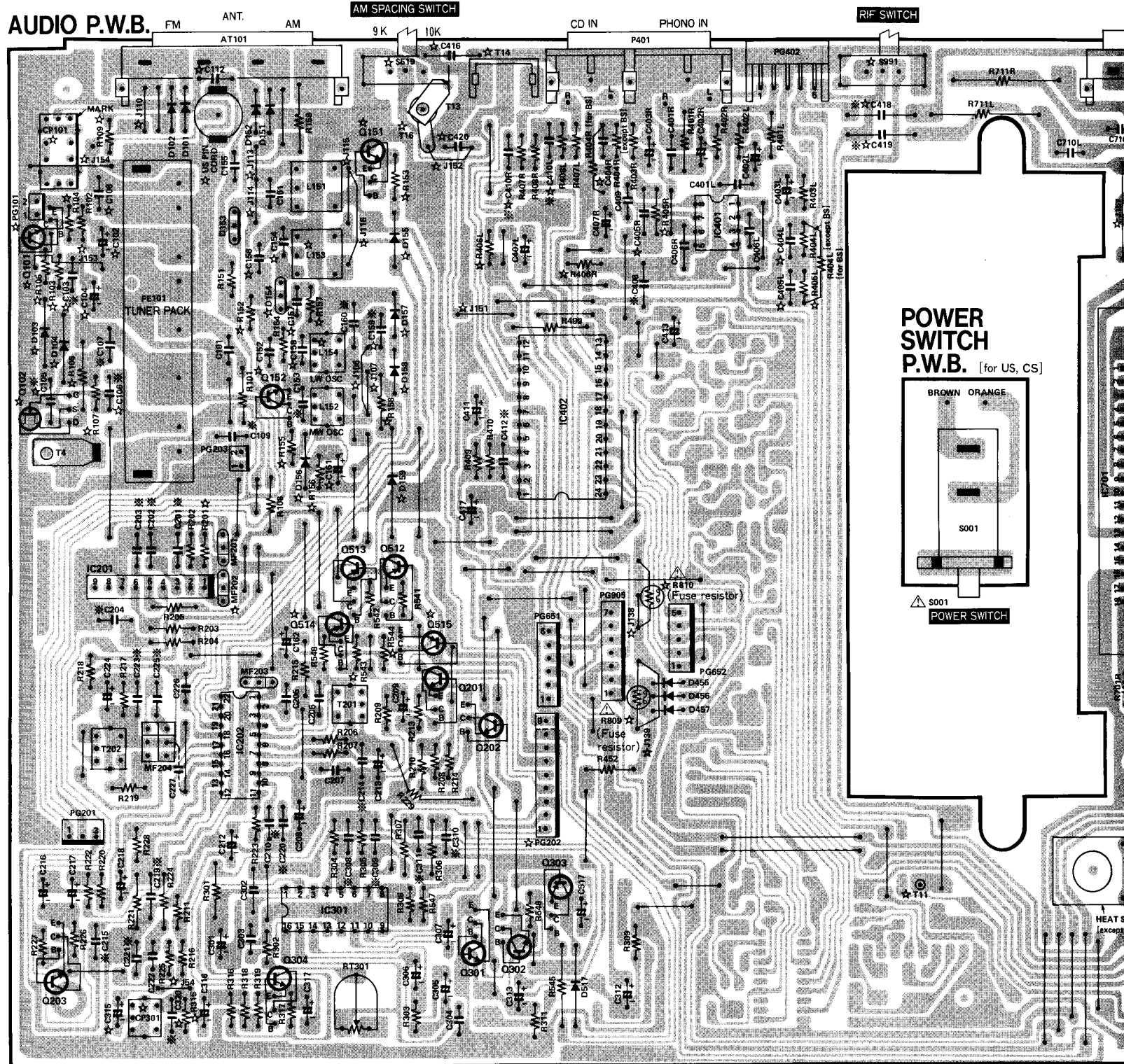

## POWER SWITCH P.W.B. [for US, CS]

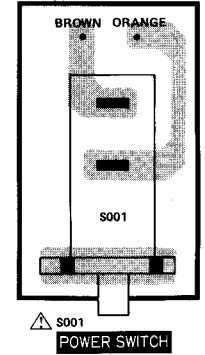

T201

FM DISCRIMINATOR ADJ.

L151

MW ANT. ADJ.

L153

LW ANT. ADJ.

RT301

FM MPX VCO ADJ.

T202

AM IF ADJ.

L152

MW OSC ADJ.

L154

LW OSC ADJ.

IC402

Pin No.	Voltage	Pin No.	Voltage
1	0	13	0
2	12.7	14	0
3	0	15	0
4	0	16	0
5	0	17	0
6	0	18	0
7	0	19	0
8	0	20	0
9	0	21	0
10	0	22	0
11	0	23	0
12	-14.5	24	13.0

IC201

Pin No.	1	2	3	4	5	6	7	8	9
Voltage	2.7	2.7	2.9	3.0	4.9	3.0	0	2.2	2.9

Pin No.

Pin No.	1	2	3	4	5	6	7	8
IC401	0	0	0	-14.5	0	0	0	13.0
IC751	0	0	0	1.9	0	0.7	2.2	3.3

Pin No.

Pin No.	1	2	3	4	5	6	7
IC301	6.5	2.3	1.7	2.6	2.6	5.2	0
Pin No.	9	10	11	12	13	14	15
IC301	7.3	1.4	1.4	—	1.4	1.4	1.4

The circuit symbol (☆) means difference for destination. (Refer to the table in page 19,20.)  
 Das Schaltkreissymbol (☆) weist auf unterschiedliche Zielrichtungen hin. (Siehe die Tabelle auf Seite 19,20.)  
 Le symbol de circuit (☆) signifie qu'il s'agit des différence pour destination. (Consulter la table dans le page 19,20.)

**POWER SUPPLY P.W.B.**

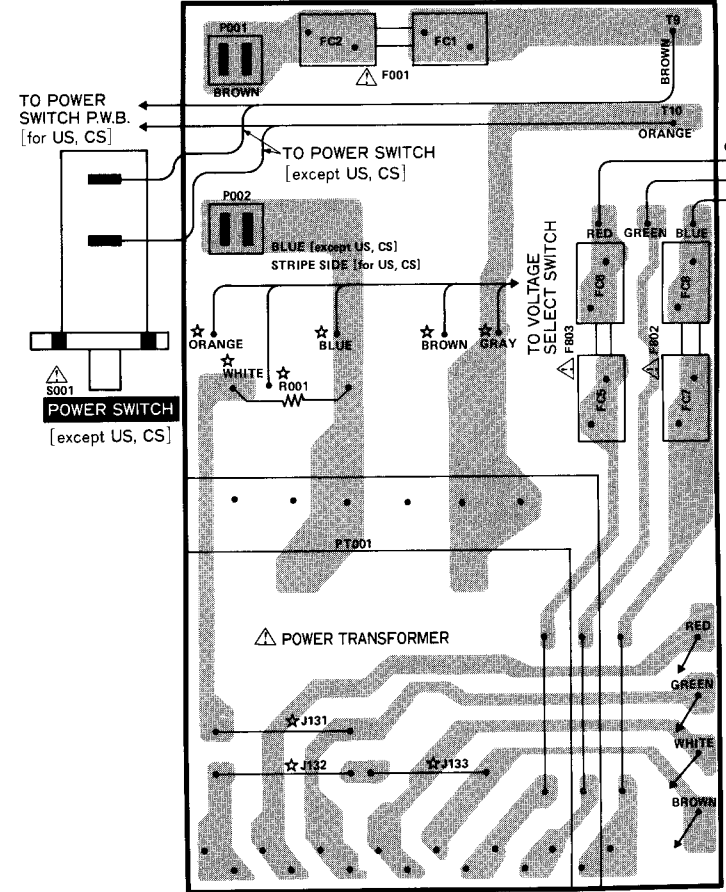

**HEADPHONES P.W.B.**

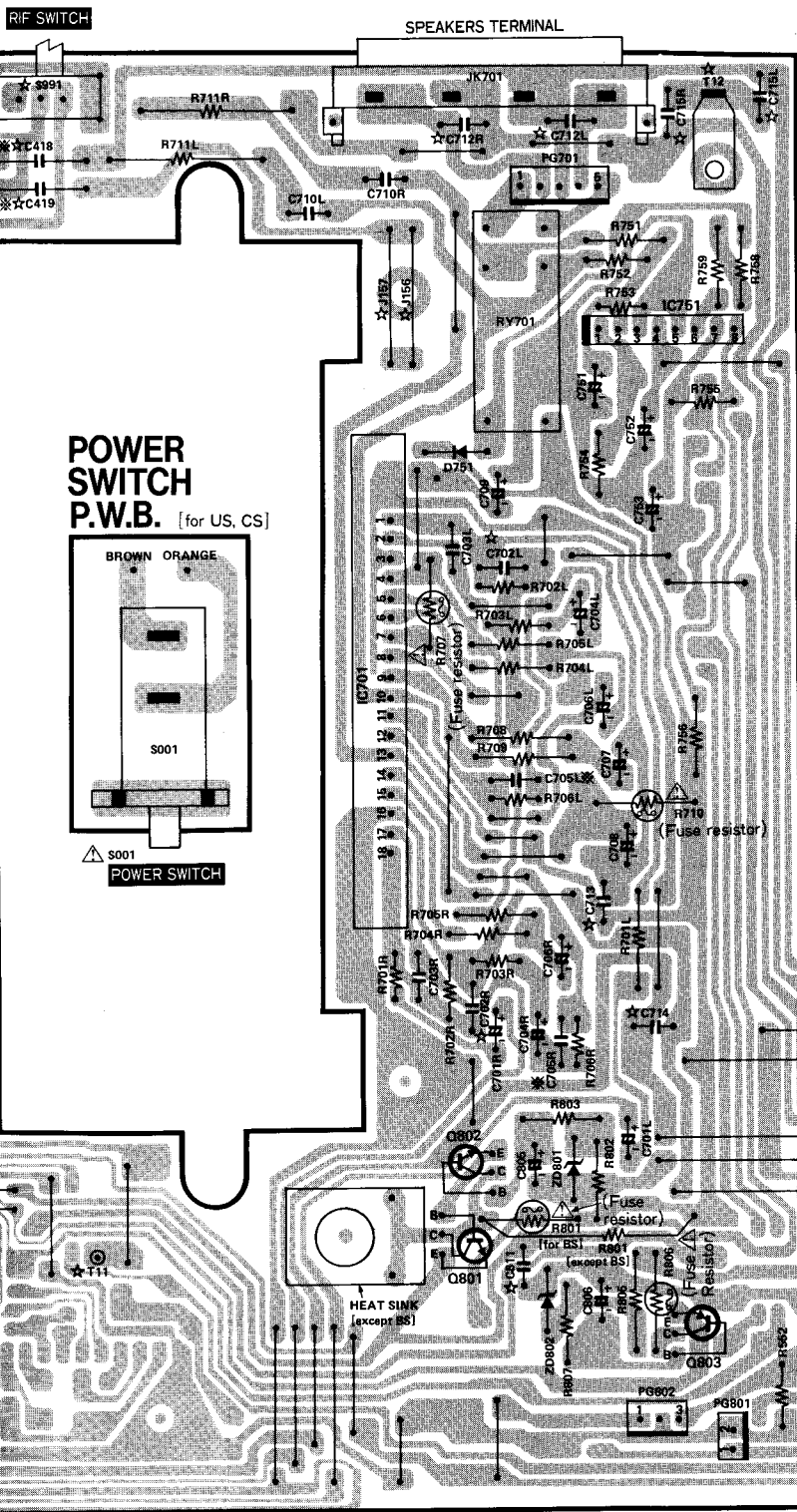
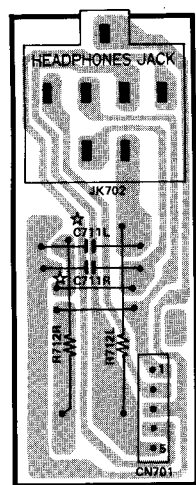

**POWER SWITCH P.W.B. [for US, CS]**

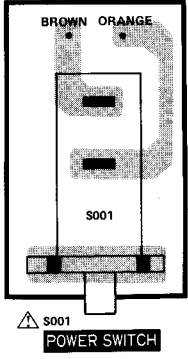

Pin No.	1	2	3	4	5	6	7	8
IC301	6.5	2.3	1.7	2.6	2.6	5.2	0	0.6
Pin No.	9	10	11	12	13	14	15	16
IC301	7.3	1.4	1.4	—	1.4	1.4	1.4	0.1

	E	C	B
Q801	14.0 (11.8)	31.4 (19.9)	14.6 (12.3)
Q802	14.6 (12.3)	31.4 (19.9)	15.2 (12.9)
Q803	-14.4 (-12.4)	-34.5 (-21.2)	-14.9 (-13.0)

( ) : for BS

Pin No.	1	2	3	4	5	6	7	8	9	10	11
Voltage	2.3 (1.1)	2.3 (1.1)	2.3 (1.1)	0 (0)	8.8 (9.1)	8.7 (9.1)	8.6 (9.1)	0 (5.0)	3.8 (3.5)	3.0 (3.0)	1.3 (1.3)
Pin No.	12	13	14	15	16	17	18	19	20	21	22
Voltage	1.5 (1.5)	1.2 (0)	1.2 (0)	2.3 (1.1)	1.4 (1.5)	0.4 (9.4)	0 (2.0)	0 (2.0)	3.8 (3.7)	3.9 (3.7)	2.8 (1.6)

( ) : LW

IC502 1 pin	
AM	4.9
FM	0
MW	0
LW	4.9

( ) : MW ( ) : LW

	E	C	B
Q301	0	0	0.6
Q302	0	0	0.6
Q303	11.2 (11.7)	11.2 (0)	10.6 (10.6)
Q304	1.0	3.2	1.6
Q511	5.1	0	5.0
Q512	11.8 (11.8)	0.5 (11.9)	11.1 (11.7)
Q513	11.8 (11.8)	0.5 (11.8)	11.1 (11.0)
Q514	0.5 (11.9)	0 (0.2)	0 (11.2)
Q515	0.5 (11.9)	0.5 (11.8)	0 (11.2)

**PRINTED WIRING BOARD  
PRINTPLATTEN  
PLAN DE BASE**

- ※ : Axial leaded ceramic capacitor.
- ※ : Zylindrischer Keramikcondensator mit axialer Zuleitung.
- ※ : Condensateur céramique cylindrique à conducteur axial.

The circuit symbol (☆)  
Das Schaltkreissymbol  
Le symbol de circuit (☆)

**DECK P.W.B.**

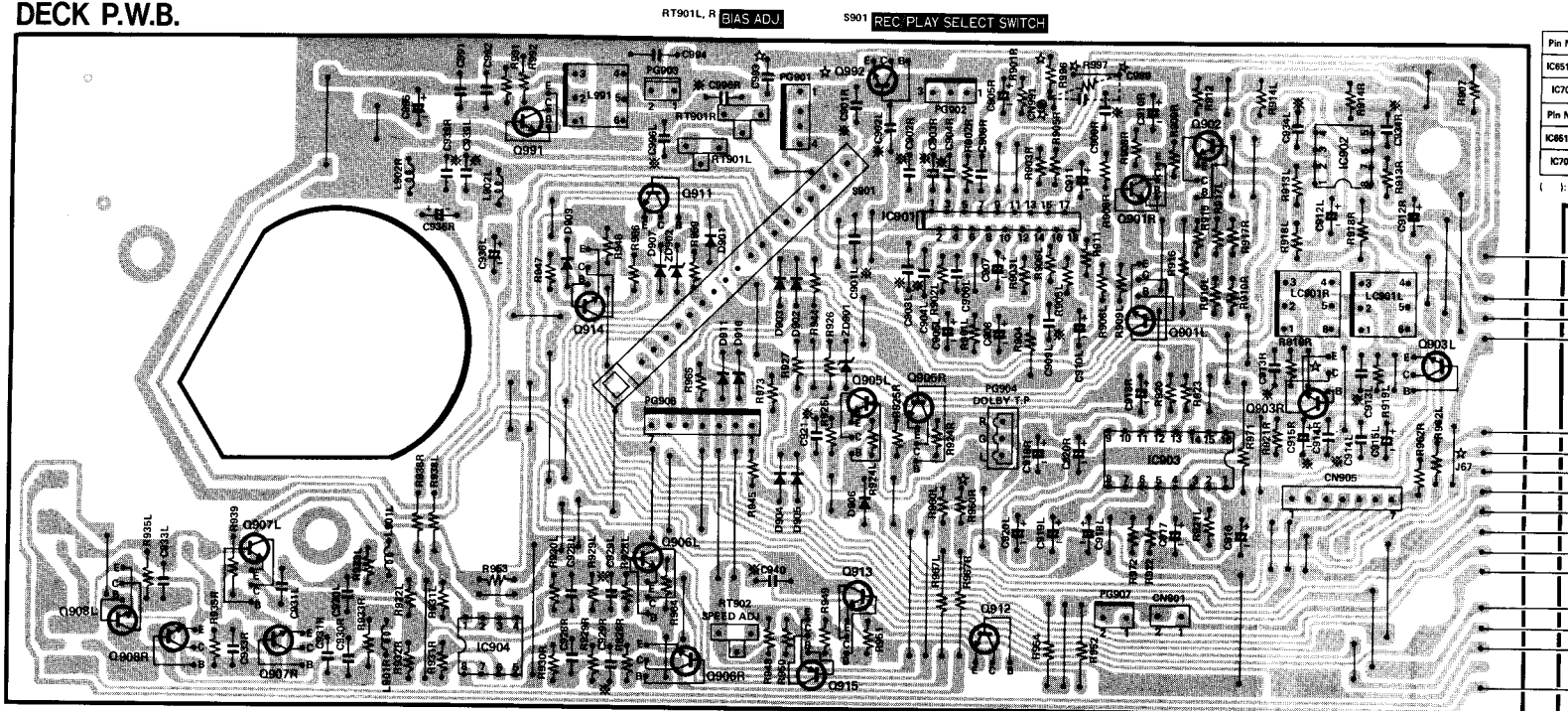

RT901L, R BIAS ADJ 5901 REC. PLAY SELECT SWITCH

RT902 TAPE SPEED ADJ

IC901 Pin No.	Voltage	Pin No.	Voltage
1	0	10	7.5
2	0	11	1.9
3	0	12	7.9
4	0	13	2.8
5	0.6	14	2.8
6	0.6	15	0
7	NOR: 0 Cr-O: 2.4	16	0
8	0	17	0
9	0	18	TAPE 2 PLAY -2.5

IC903 Pin No.	Voltage	Pin No.	Voltage
1	6.6	9	6.6
2	12.7	10	0.4
3	6.6	11	6.6
4	6.6	12	PB: 3.7 REC: 0
5	ON: 0 OFF: 7.6	13	1.2
6	6.6	14	6.6
7	0.4	15	0
8	6.6	16	6.6

Pin No.	1	2	3	4	5	6	7	8
IC902	0	0	0	-14.6	0	0	0	14.1
IC904	0	0	0	-14.6	0	0	0	14.1

**DISPLAY P.W.B.**

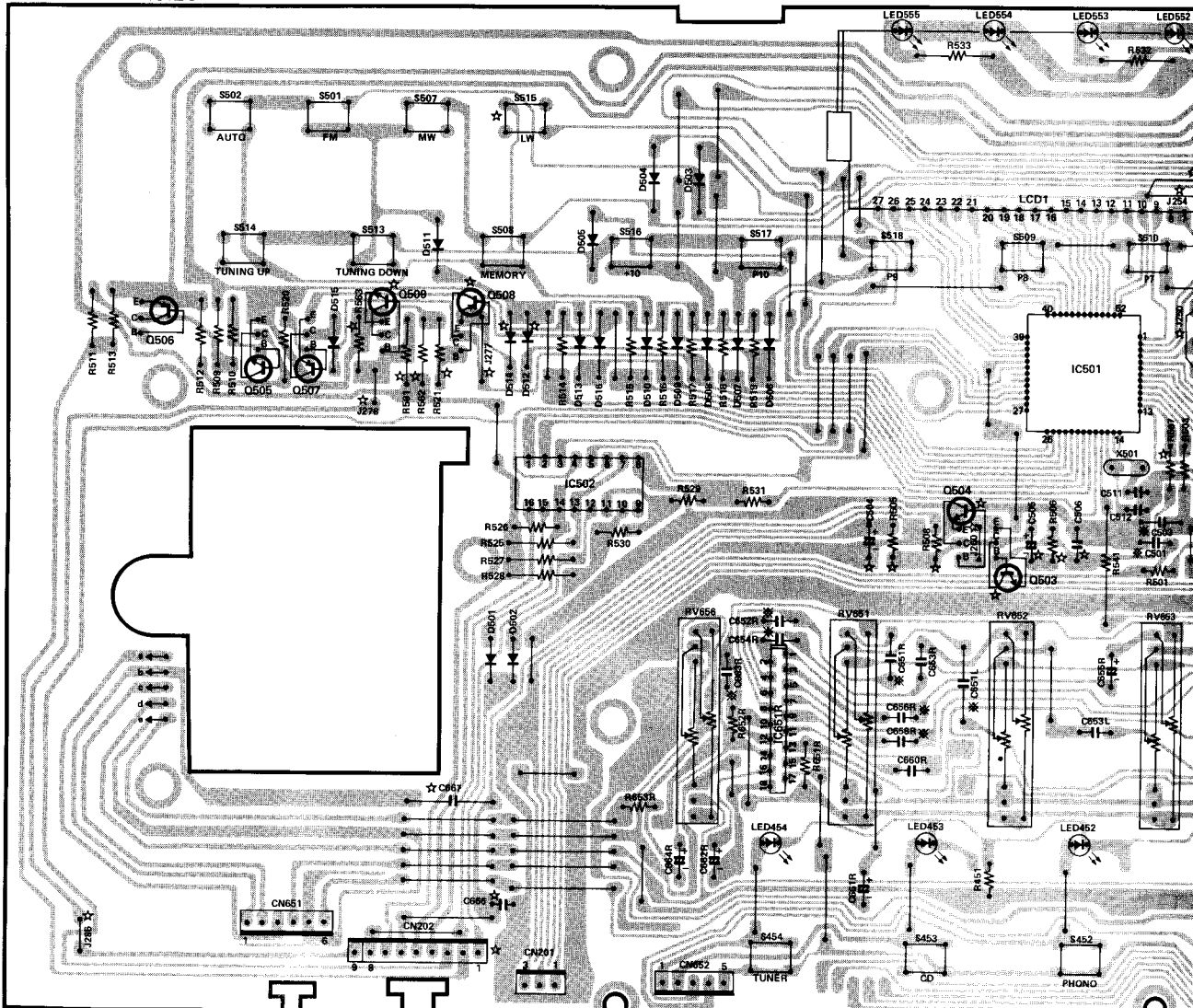

**DISPLAY P.W.B.**

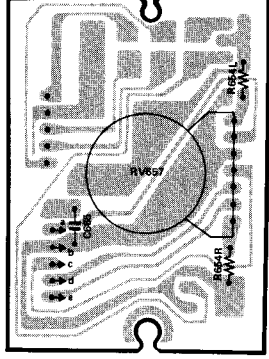

RV657  
VOLUME CONTROL

RV651-655  
GRAPHIC EQUALIZER CONTROL

RV650  
BALANCE

mit axialer Zuleitung.  
à conducteur axial.

The circuit symbol (☆) means difference for destination. (Refer to the table in page 18.)  
Das Schaltkreissymbol (☆) weist auf unterschiedliche Zielrichtungen hin. (Siehe die Tabelle auf Seite 18.)  
Le symbol de circuit (☆) signifie qu'il s'agit des différence pour destination. (Consulter la table dans le page 18.)

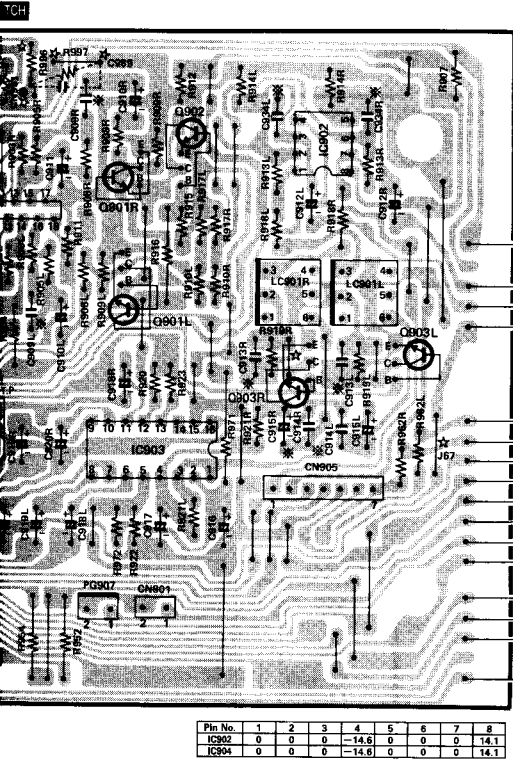

Pin No.	1	2	3	4	5	6	7	8
IC903	0	0	0	-14.6	0	0	0	14.1
IC904	0	0	0	-14.6	0	0	0	14.1

Pin No.	1	2	3	4	5	6	7	8	9
IC651LR	6.2	7.3	7.3	6.2	6.2	7.3	7.3	6.2	6.2
IC701	0	0	0	-32.8	-1.3	0	-34.6	-35.3	-35.9
				(-18.9)	(-1.4)		(-20.3)	(-21.0)	(-21.4)
Pin No.	10	11	12	13	14	15	16	17	18
IC651LR	6.5	7.3	6.5	6.5	6.7	7.1	7.3	12.7	0
IC701	0	34.7	33.2	0	-35.9	-1.3	0	0	0
		(20.4)	(19.2)		(-21.4)	(-1.4)			

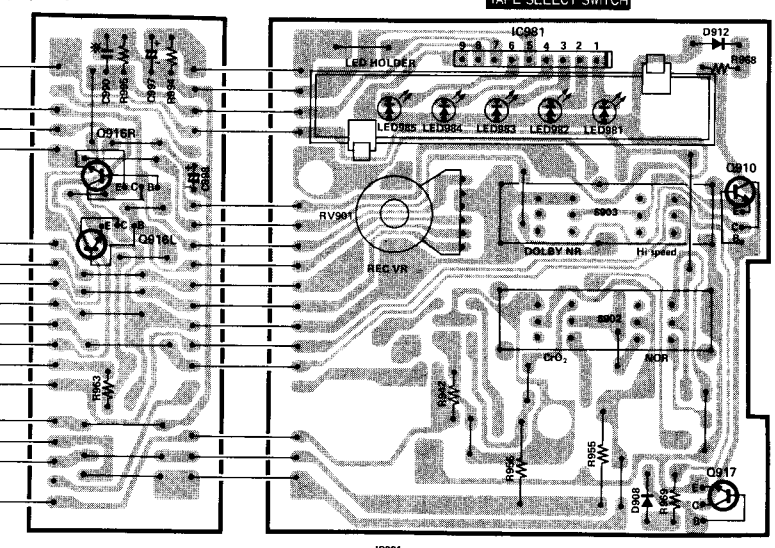

- RV901 REC LEVEL CONTROL
- S903 DUBBING SPEED DOLBY NR SELECT SWITCH
- S902 TAPE SELECT SWITCH

	E	C	B
Q903LR	—	—	HIGH SPEED 2
Q905LR	—	—	REC 0.6
Q906LR	—	—	PLAY 0.6
Q912	—	—	0.6 (0)
Q913	—	10.0 (0)	0 (0.6)
Q915	10.8 (10.8)	7.2 (10.8)	0 (10.8)

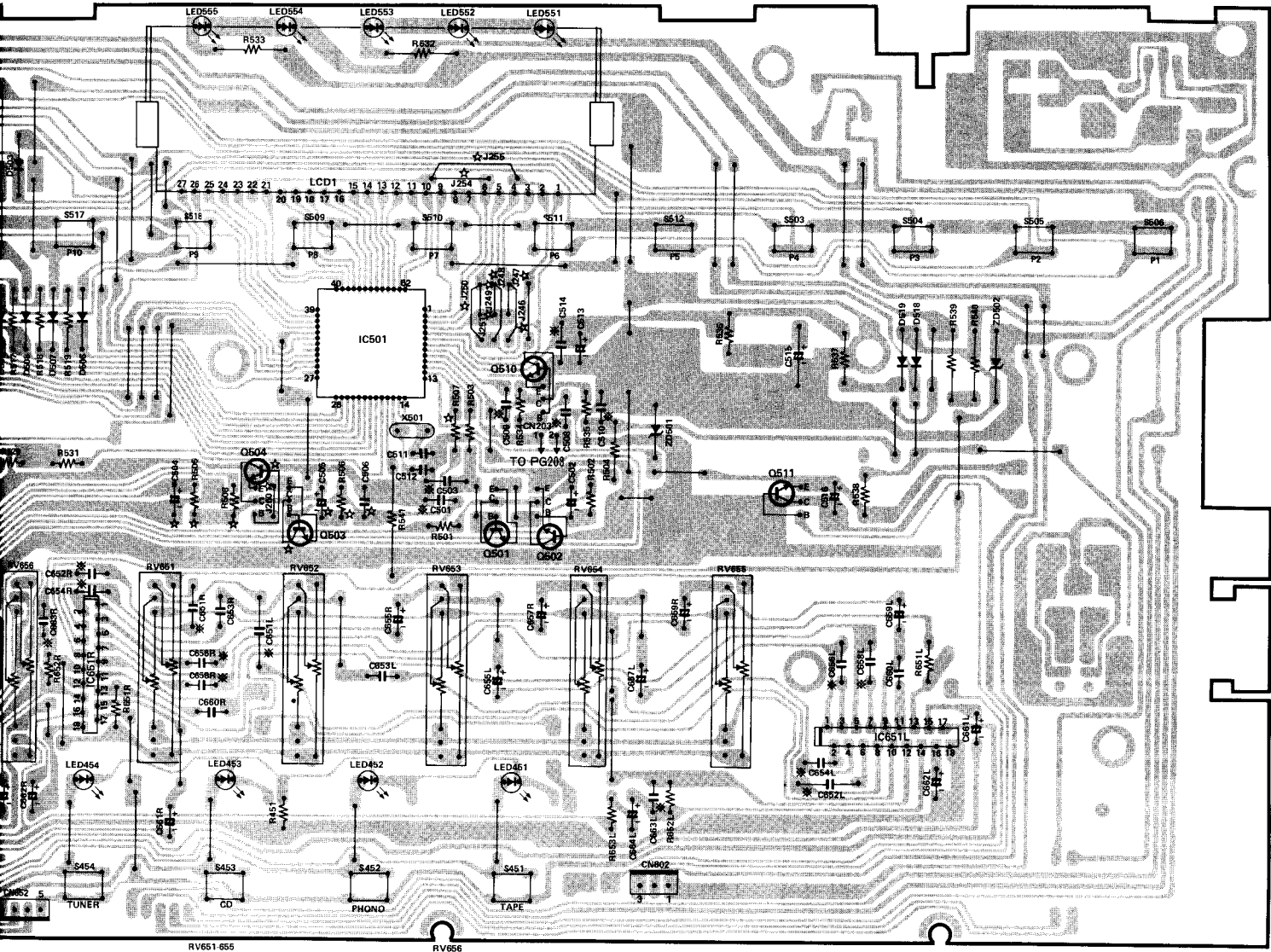

- RV651-655 GRAPHIC EQUALIZER CONTROL
- RV656 BALANCE CONTROL

WIRING DIAGRAM · VERDRAHTUNGSSCHEMA · SCHEMA DE CÂBLAGE

DECK P.W.B.

DISPLAY P.W.B.

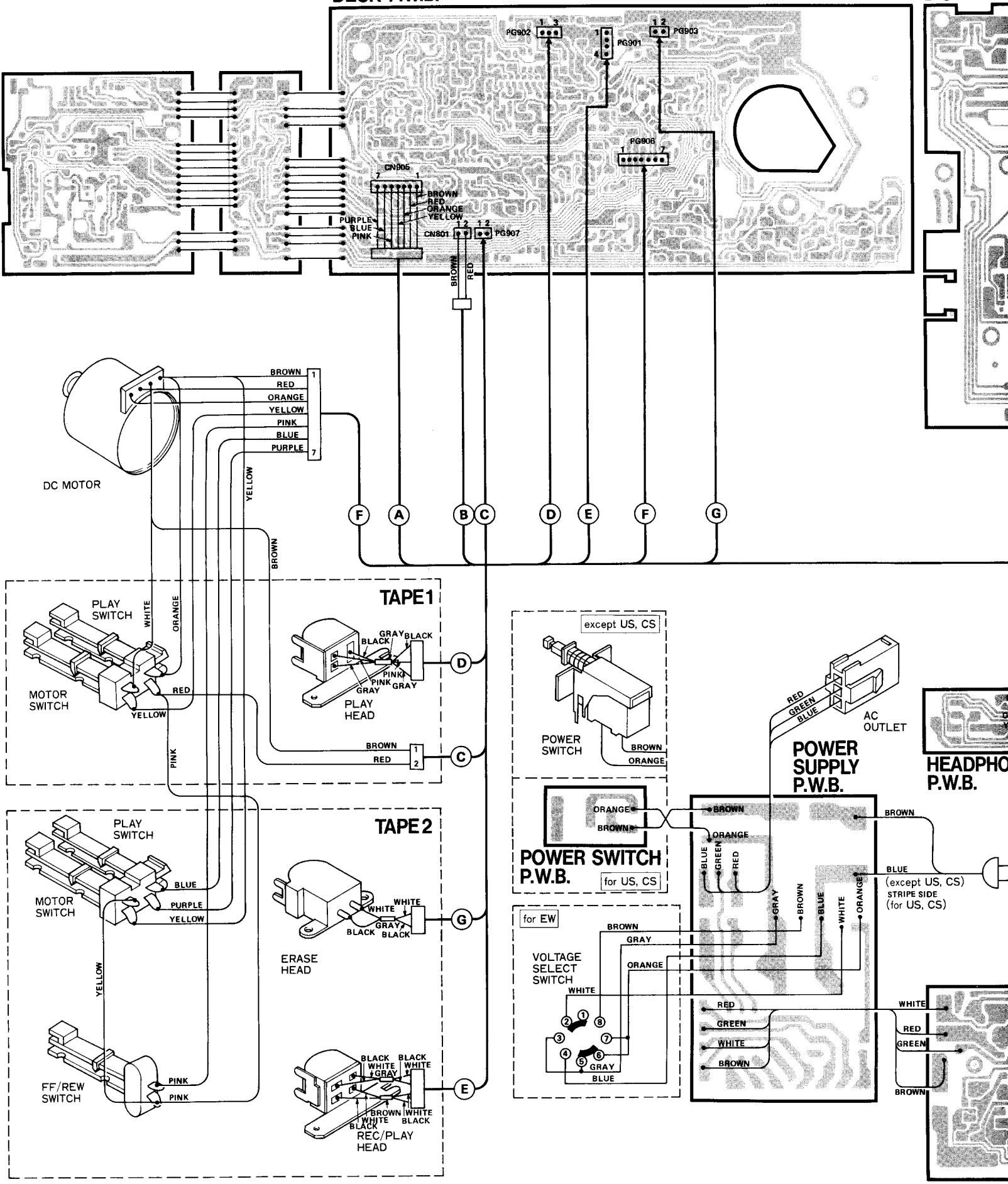

DISPLAY P.W.B.

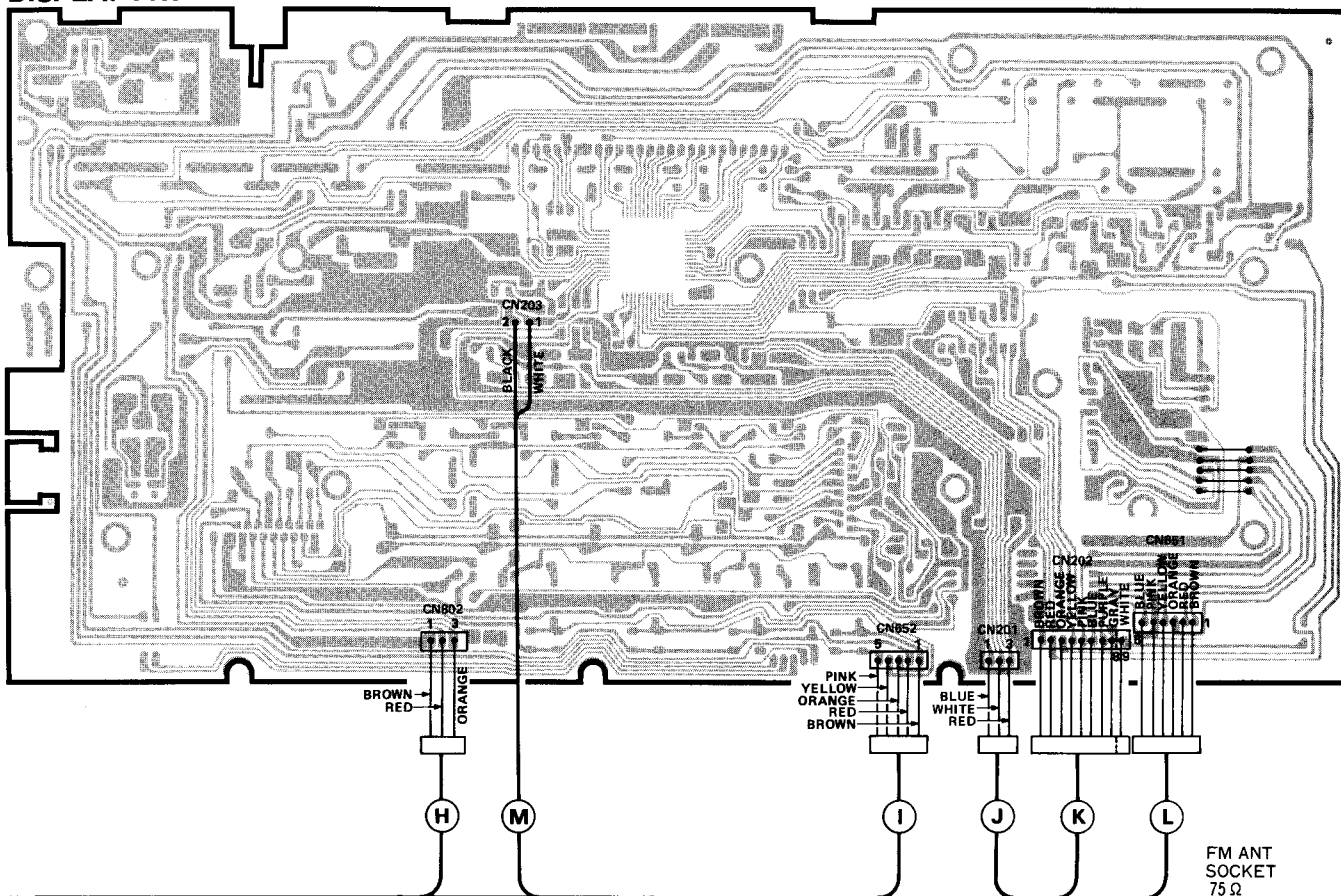
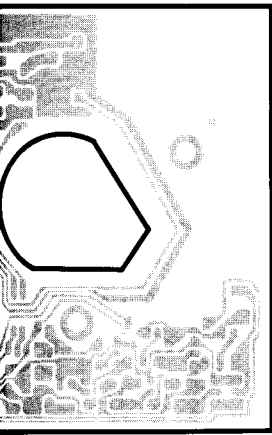

AUDIO P.W.B.

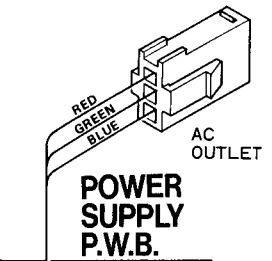

POWER SUPPLY P.W.B.



HEADPHONES P.W.B.

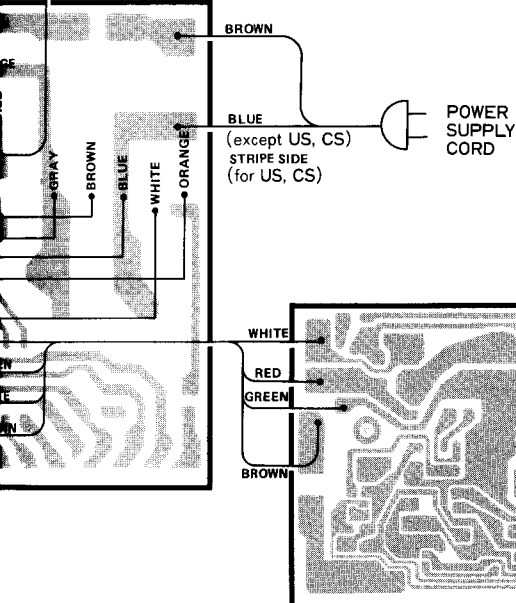



EXPLODED VIEW  
(Cabinet)

EXPLOSIONSANSICHT  
(Chassis)

VUE EXPLOSEE  
(Coffret)

- Nos.
- Dies
- Ces

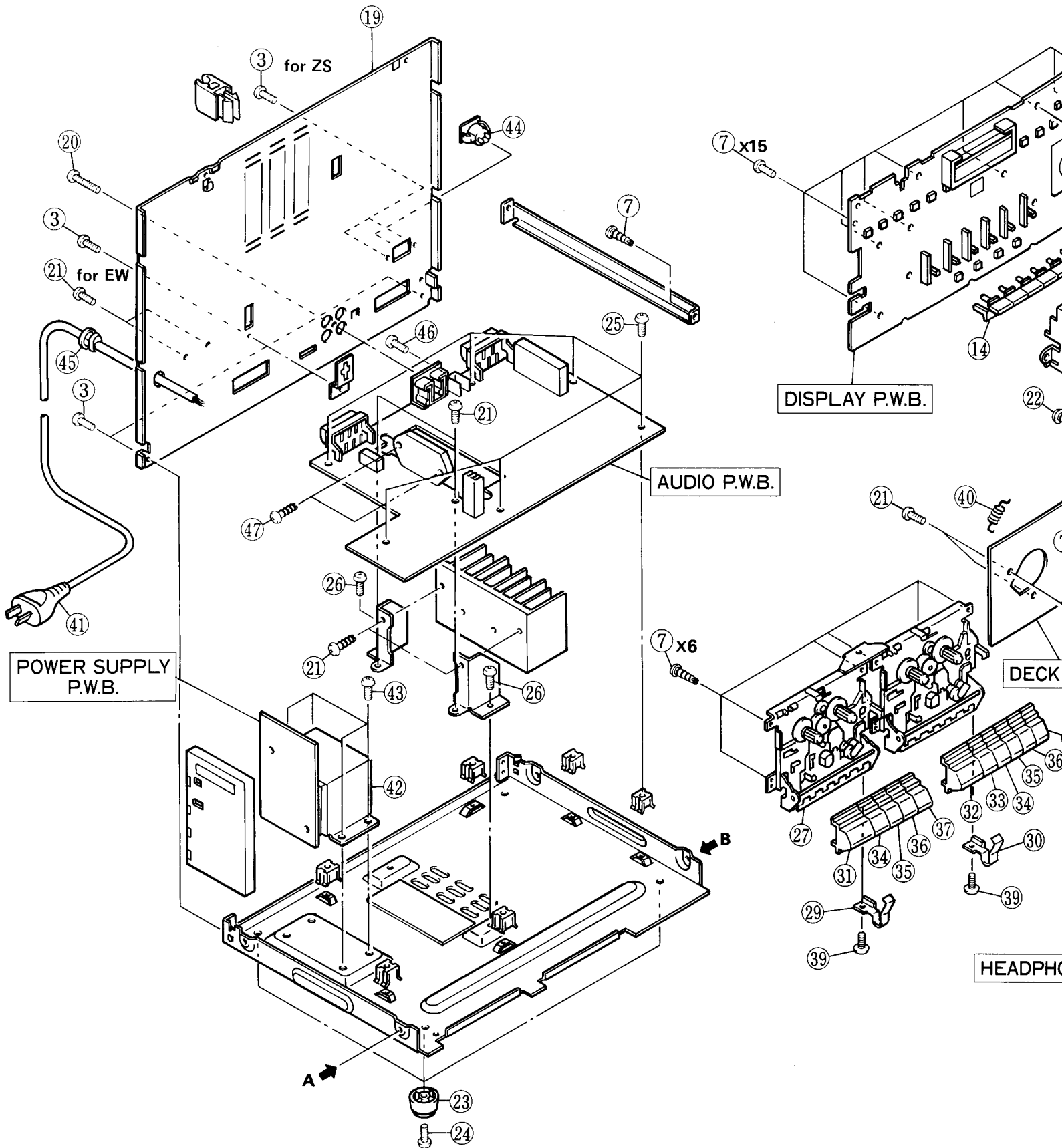

**EXPLOSEE  
Coffret)**

- Nos. are reference Nos. of parts list.
- Diese Numerierung bezieht sich auf die Teileliste.
- Ces numéros correspondent à la liste des pièces.

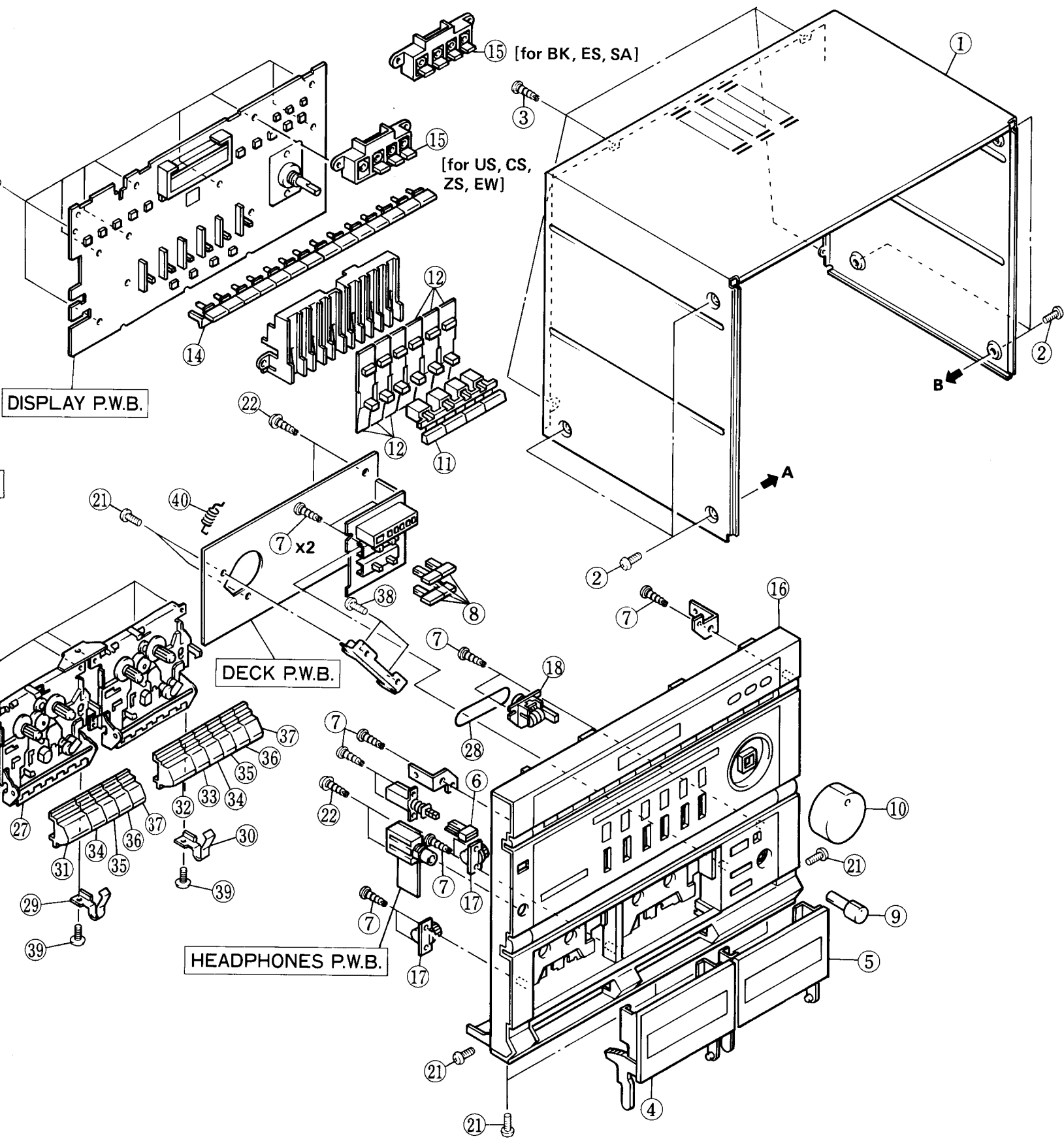

**EXPLODED VIEW EXPLOSIONSANSICHT VUE EXPLOSEE**  
**(Cassette Chasis) (Casseterdech-Chassis) (Châssis de Cassette)**

MD30

- Nos. are reference Nos. of parts list.
- Diese Numerierung bezieht sich auf die Teileliste.
- Ces numéros correspondent à la liste des pièces.

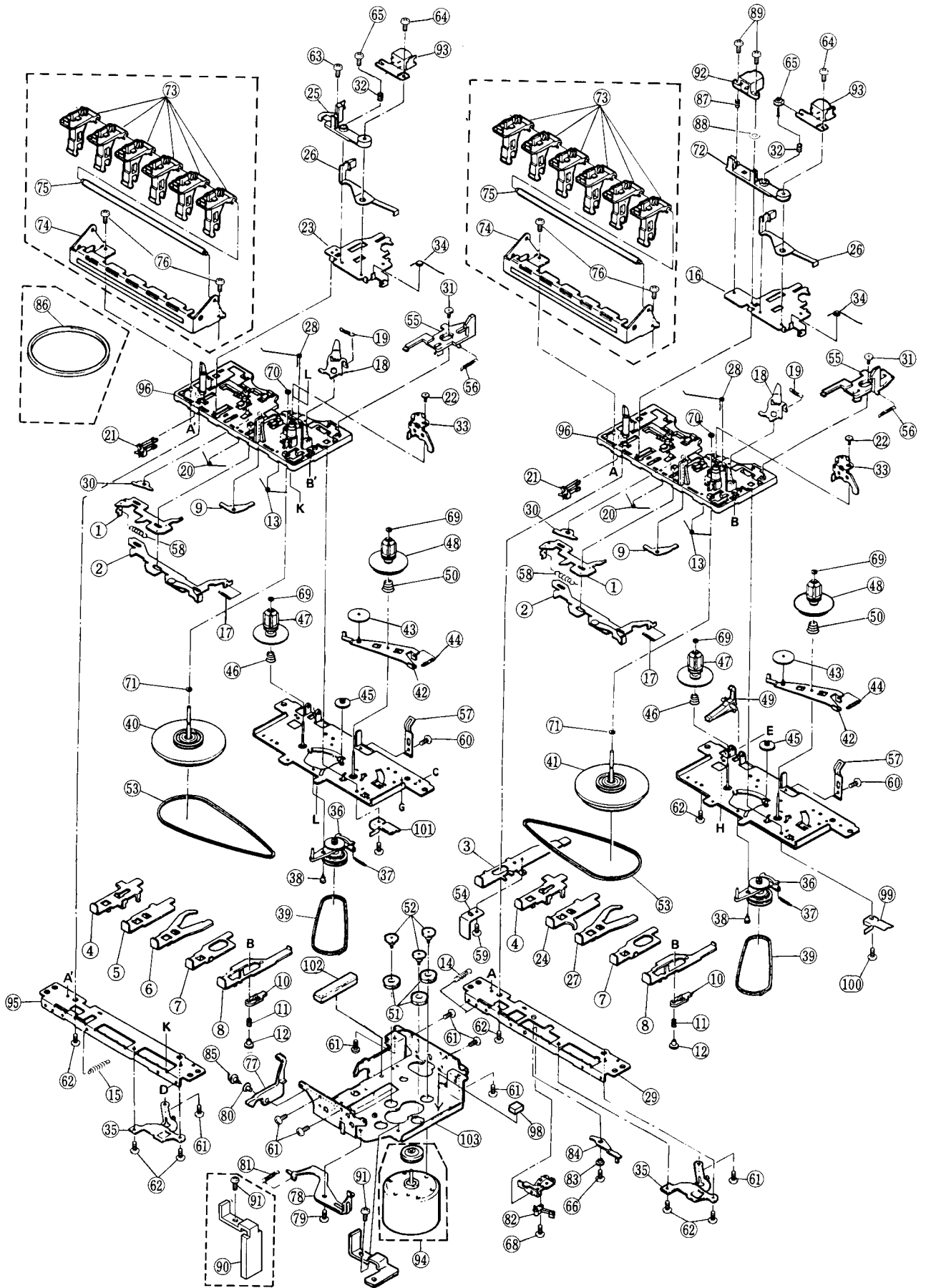

1

2

3

4

5

- Nos. are reference Nos. of parts list.
- Diese Numerierung bezieht sich auf die Teileliste.
- Ces numéros correspondent à la liste des pièces.

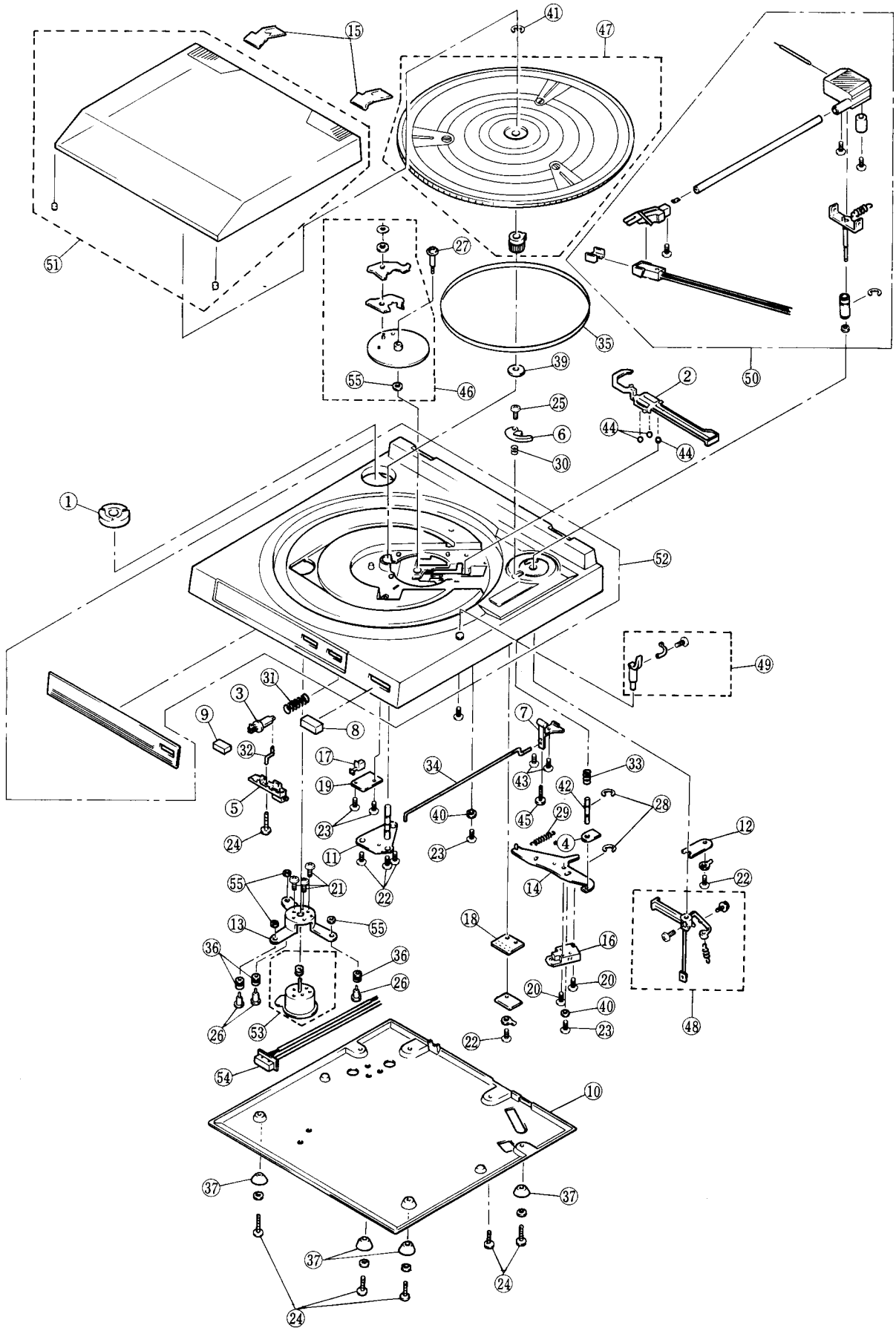

A  
B  
C  
D  
E  
F  
G

# REPLACEMENT PARTS LIST

## ERSATZTEILLISTE

## TABLEAU DES PIÈCES

CC : Cylindrical ceramic  
 CD : Ceramic discal  
 EF : Electrolytic  
 MF : Mylar film

CF : Carbon film  
 MO : Metal oxide  
 FR : Fuse resistor  
 ME : Metal

MD30

SYMBOL No.	PART No.	DESCRIPTION	SYMBOL No.	PART No.	DESCRIPTION	SYMBOL No.	PART No.	DESCRIPTION
CAPACITORS			C222	0240220	CD 0.047 $\mu$ F $\pm 10\%$ 25V	C419	0240066	CC 0.022 $\mu$ F $\pm 80\%$ 16V [for ZS]
C101	02750152	MF 0.047 $\mu$ F $\pm 10\%$ 50V	C223	0240066	CC 0.022 $\mu$ F $\pm 80\%$ 16V	C420	0276011	MF 0.1 $\mu$ F $\pm 10\%$ 50V [for ZS]
C102	02528022	EL 0.22 $\mu$ F [for ZS]	C224	0252521	EL 10 $\mu$ F 16V	C501	0240053	CC 2200PF $\pm 20\%$ 16V
C103	0240066	CC 0.022 $\mu$ F $\pm 80\%$ 16V [for ZS]	C225	0230628	CC 47PF $\pm 5\%$ 50V	C502	02528802	EL 4.7 $\mu$ F 50V
C104	0252811	EL 1 $\mu$ F [for ZS]	C226	0240220	CD 0.047 $\mu$ F $\pm 10\%$ 25V	C503	0240066	CC 0.022 $\mu$ F $\pm 80\%$ 16V
C105	0230626	CC 39PF $\pm 5\%$ 50V [for ZS]	C227	0240039	CC 330PF $\pm 10\%$ 50V	C504	02528022	EL 0.22 $\mu$ F $\pm 80\%$ 50V [for BS, ES]
C106	0230626	CC 39PF $\pm 5\%$ 50V [for ZS]	C301	0252525	EL 47 $\mu$ F 16V	C505	0252811	EL 1 $\mu$ F 50V [for BS, ES]
C107	0240066	CC 0.022 $\mu$ F $\pm 80\%$ 16V	C302	0240045	CC 1000PF $\pm 10\%$ 50V	C506	0240222	CD 0.068 $\mu$ F $\pm 10\%$ 25V [for BS, ES]
C108	0230620	CC 22PF $\pm 5\%$ 50V [for ZS]	C303	02750152	MF 0.047 $\mu$ F $\pm 10\%$ 50V	C508	0230624	CC 33PF $\pm 5\%$ 50V
C108	0230614	CC 12PF $\pm 5\%$ 50V [for ES, BS, SA]	C304	0268446	PP 1000PF $\pm 5\%$ 100V	C509	0230616	CC 15PF $\pm 5\%$ 50V
C109	0230624	CC 33PF $\pm 5\%$ 50V	C305	02528052	EL 0.47 $\mu$ F 50V	C510	0240066	CC 0.022 $\mu$ F $\pm 80\%$ 16V
C112	0240061	CC 0.01 $\mu$ F $\pm 30\%$ 16V [for ZS]	C306	02528052	EL 0.47 $\mu$ F 50V	C511	0246449	CD 24PF $\pm 5\%$ 50V
C151	0246416	CD 6PF $\pm 0.25$ PF 50V [for BS, ES]	C307	0252811	EL 1 $\mu$ F 50V	C512	02464492	CD 24PF $\pm 5\%$ 50V
C151	0246412	CD 2PF $\pm 0.25$ PF 50V [except BS, ES]	C308	0240058	CC 5600PF $\pm 30\%$ 16V [for ZS]	C513	02522422	EL 2200 $\mu$ F 6.3V
C152	0268323	PP 510PF $\pm 5\%$ 100V	C309	0240058	CC 5600PF $\pm 30\%$ 16V [for ZS]	C514	0240066	CC 0.022 $\mu$ F $\pm 80\%$ 16V
C153	0230654	CC 12PF $\pm 5\%$ 50V	C309	0240061	CC 0.01 $\mu$ F $\pm 30\%$ 16V [for US, CS]	C515	0259421	Super capacitor 22000 $\mu$ F
C154	0246453	CD 36PF $\pm 5\%$ 50V [for BS, ES]	C309	0240060	CC 8200PF $\pm 30\%$ 16V [except US, CS, ZS]	C516	0252815	EL 4.7 $\mu$ F 50V
C155	02752132	MF 0.022 $\mu$ F $\pm 5\%$ 50V	C310	0240057	CC 4700PF $\pm 20\%$ 16V [for US, CS]	C517	0252522	EL 22 $\mu$ F 16V
C156	0275213	MF 0.022 $\mu$ F $\pm 5\%$ 50V [for BS, ES]	C310	0240053	CC 2200PF $\pm 20\%$ 16V [except US, CS]	C551	0252821	EL 10 $\mu$ F 50V
C157	0228321	ST 270PF $\pm 5\%$ 50V [for BS, ES]	C311	0240057	CC 4700PF $\pm 20\%$ 16V [for US, CS]	C552	0252815	EL 4.7 $\mu$ F 50V
C158	0246465	CD 110PF $\pm 5\%$ 50V [for BS, ES]	C311	0240053	CC 2200PF $\pm 20\%$ 16V [except US, CS]	C553	0252821	EL 10 $\mu$ F 50V
C159	0240066	CC 0.022 $\mu$ F $\pm 80\%$ 16V [for BS, ES]	C312	0252813	EL 3.3 $\mu$ F 50V	C651LR	0240058	CC 5600PF $\pm 30\%$ 16V
C160	0240066	CC 0.022 $\mu$ F $\pm 80\%$ 16V	C313	0252813	EL 3.3 $\mu$ F 50V	C652LR	0240037	CC 220PF $\pm 10\%$ 50V
C161	0252811	EL 1 $\mu$ F [for BS, ES]	C315	0252813	EL 3.3 $\mu$ F 50V [for ZS]	C653LR	0240218	CD 0.033 $\mu$ F $\pm 10\%$ 25V
C162	0252521	EL 10 $\mu$ F 16V	C316	0252813	EL 3.3 $\mu$ F 50V	C654LR	0240044	CC 820PF $\pm 10\%$ 50V
C201	0240066	CC 0.022 $\mu$ F $\pm 80\%$ 16V	C317	0252813	EL 3.3 $\mu$ F 50V	C655LR	02528012	EL 0.1 $\mu$ F 50V
C202	0240066	CC 0.022 $\mu$ F $\pm 80\%$ 16V	C320	0240042	CC 560PF $\pm 10\%$ 50V [for ZS]	C656LR	0240054	CC 2700PF $\pm 20\%$ 16V
C203	0240066	CC 0.022 $\mu$ F $\pm 80\%$ 16V	C401LR	0240045	CC 1000PF $\pm 10\%$ 50V [except ZS]	C657LR	0252805	EL 0.47 $\mu$ F 50V
C204	0240061	CC 0.01 $\mu$ F $\pm 30\%$ 16V	C402LR	0252813	EL 3.3 $\mu$ F 50V	C658LR	0240061	CC 0.01 $\mu$ F $\pm 30\%$ 16V
C205	0240220	CD 0.047 $\mu$ F $\pm 10\%$ 25V	C403LR	02522252	EL 47 $\mu$ F 6.3V	C659LR	0252812	EL 2.2 $\mu$ F 50V
C206	0240061	CC 0.01 $\mu$ F $\pm 30\%$ 16V	C404LR	0240060	CC 8200PF $\pm 30\%$ 16V [except BS]	C660LR	0240218	CD 0.033 $\mu$ F $\pm 10\%$ 25V
C207	0240220	CD 0.047 $\mu$ F $\pm 10\%$ 25V	C405LR	0240053	CC 2200PF $\pm 20\%$ 16V [except BS]	C661LR	0252813	EL 3.3 $\mu$ F 50V
C208	0252811	EL 1 $\mu$ F 50V	C406LR	0240033	CC 100PF $\pm 10\%$ 50V	C662LR	0252522	EL 22 $\mu$ F 16V
C209	0252813	EL 3.3 $\mu$ F 50V	C407LR	0252811	EL 1 $\mu$ F 50V	C663LR	0240045	CC 1000PF $\pm 10\%$ 50V
C210	0240033	CC 100PF $\pm 10\%$ 50V	C408	0240066	CC 0.022 $\mu$ F $\pm 80\%$ 16V	C664LR	0252813	EL 3.3 $\mu$ F 50V
C212	0252521	EL 10 $\mu$ F 16V	C409	0240066	CC 0.022 $\mu$ F $\pm 80\%$ 16V	C665	0240066	CC 0.022 $\mu$ F $\pm 80\%$ 16V [for ZS]
C213	0252525	EL 47 $\mu$ F 16V	C410LR	0240037	CC 220PF $\pm 10\%$ 50V [for ZS]	C666	0240066	CC 0.022 $\mu$ F $\pm 80\%$ 16V [for ES, BS]
C214	0240061	CC 0.01 $\mu$ F $\pm 30\%$ 16V	C411	0252811	EL 1 $\mu$ F 50V	C667	0240066	CC 0.022 $\mu$ F $\pm 80\%$ 16V [for ES, BS]
C215	0240066	CC 0.022 $\mu$ F $\pm 80\%$ 16V	C412	0240066	CC 0.022 $\mu$ F $\pm 80\%$ 16V	C701LR	0252813	EL 3.3 $\mu$ F 50V
C216	0252815	EL 4.7 $\mu$ F 50V	C413	0252802	EL 0.22 $\mu$ F 50V	C702LR	0240037	CC 220PF $\pm 10\%$ 50V [except ZS]
C217	0252813	EL 3.3 $\mu$ F 50V	C416	0240061	CC 0.01 $\mu$ F $\pm 30\%$ 16V	C703LR	0240039	CC 330PF $\pm 10\%$ 50V [except ZS]
C218	0252521	EL 10 $\mu$ F 16V	C417	0252813	EL 3.3 $\mu$ F 50V	C703LR	0240045	CC 1000PF $\pm 10\%$ 50V [for ZS]
C219	0240045	CC 1000PF $\pm 10\%$ 50V	C418	0240066	CC 0.022 $\mu$ F $\pm 80\%$ 16V [for ZS]	C704LR	02522252	EL 47 $\mu$ F 6.3V
C220	0240061	CC 0.01 $\mu$ F $\pm 30\%$ 16V				C705LR	0230612	CC 10PF $\pm 5\%$ 50V
C221	0240061	CC 0.01 $\mu$ F $\pm 30\%$ 16V				C706LR	02526252	EL 47 $\mu$ F 25V

SYMBOL No.	PART No.	DESCRIPTION	SYMBOL No.	PART No.	DESCRIPTION	SYMBOL No.	PART No.	DESCRIPTION			
C712LR	02441732	CD 0.022 $\mu$ F $\pm 80\%$ [for ZS]	50V	C939LR	0240036	CC 180PF $\pm 10\%$	50V	R207	0113639	CF 10K $\Omega$ $\pm 5\%$	SRD1/6P
C713	0244173	CD 0.022 $\mu$ F $\pm 80\%$ [except BS]	50V	C940	0240061	CC 0.01 $\mu$ F $\pm 30\%$	16V	R208	0113647	CF 22K $\Omega$ $\pm 5\%$	SRD1/6P
C714	0276013	MF 0.22 $\mu$ F $\pm 10\%$ [for ZS]	50V	C989	0240061	CC 0.01 $\mu$ F $\pm 30\%$ [for BS, ES]	16V	R209	0113639	CF 10K $\Omega$ $\pm 5\%$	SRD1/6P
C715LR	0244173	CD 0.022 $\mu$ F $\pm 80\%$ [for ZS]	50V	C990	0240037	CC 220PF $\pm 10\%$	50V	R210	0113655	CF 47K $\Omega$ $\pm 5\%$	SRD1/6P
C751	02522312	EL 100 $\mu$ F	6.3V	C991	02750122	MF 0.015 $\mu$ F $\pm 10\%$	50V	R211	0113639	CF 10K $\Omega$ $\pm 5\%$	SRD1/6P
C752	0252815	EL 4.7 $\mu$ F	50V	C992	02740162	MF 6800PF $\pm 10\%$	50V	R212	0113591	CF 100 $\Omega$ $\pm 5\%$	SRD1/6P
C753	02523232	EL 33 $\mu$ F	10V	C993	0240051	CC 1500PF $\pm 20\%$ [for BS, ES]	16V	R214	0113639	CF 10K $\Omega$ $\pm 5\%$	SRD1/6P
C801	0244173	CD 0.022 $\mu$ F $\pm 80\%$	50V	C994	0268435	MF 0.015 $\mu$ F $\pm 5\%$	100V	R215	0113643	CF 15K $\Omega$ $\pm 5\%$	SRD1/6P
C802	0244173	CD 0.022 $\mu$ F $\pm 80\%$	50V	C995	02525312	EL 100 $\mu$ F	16V	R215	0113651	CF 33K $\Omega$ $\pm 5\%$	SRD1/6P
C803	0252642	EL 2200 $\mu$ F [for BS]	25V	C996LR	0240037	CC 220PF $\pm 10\%$	50V	R216	0113645	CF 18K $\Omega$ $\pm 5\%$	SRD1/6P
C803	0255001	EL 4700 $\mu$ F [except BS]	40V	C997	0252521	EL 10 $\mu$ F	16V	R217	0113659	CF 68K $\Omega$ $\pm 5\%$	SRD1/6P
C804	0252642	EL 2200 $\mu$ F [for BS]	25V	C998	0252525	EL 47 $\mu$ F	16V	R217	0113657	CF 56K $\Omega$ $\pm 5\%$	SRD1/6P
C804	0255001	EL 4700 $\mu$ F [except BS]	40V	RESISTORS				R218	0113633	CF 5.6K $\Omega$ $\pm 5\%$	SRD1/6P
C805	0252625	EL 47 $\mu$ F [except BS]	25V	$\Delta$ R001	0139005	CO 2.7M $\Omega$ $\pm 10\%$	RC1/2GF	R218	0113641	CF 12K $\Omega$ $\pm 5\%$	SRD1/6P
C805	0252635	EL 470 $\mu$ F [for BS]	25V	R101	0113625	CF 2.7K $\Omega$ $\pm 5\%$	SRD1/6P	R219	0113601	CF 270 $\Omega$ $\pm 5\%$	SRD1/6P
C806	0252625	EL 47 $\mu$ F	25V	R102	0113663	CF 100K $\Omega$ $\pm 5\%$	SRD1/6P	R220	0113639	CF 10K $\Omega$ $\pm 5\%$	SRD1/6P
C807	0244173	CD 0.022 $\mu$ F $\pm 80\%$	50V	R103	0113663	CF 100K $\Omega$ $\pm 5\%$	SRD1/6P	R221	0113635	CF 6.8K $\Omega$ $\pm 5\%$	SRD1/6P
C808	0244173	CD 0.022 $\mu$ F $\pm 80\%$	50V	R104	0113591	CF 100 $\Omega$ $\pm 5\%$	SRD1/6P	R221	0113637	CF 8.2K $\Omega$ $\pm 5\%$	SRD1/6P
C809	0252635	EL 1000 $\mu$ F	25V	R105	0113639	CF 10K $\Omega$ $\pm 5\%$	SRD1/6P	R221	0113637	CF 8.2K $\Omega$ $\pm 5\%$	SRD1/6P
C810	0252635	EL 470 $\mu$ F	25V	R106	0113617	CF 1.2K $\Omega$ $\pm 5\%$	SRD1/6P	R222	0113639	CF 10K $\Omega$ $\pm 5\%$	SRD1/6P
C811	0276013	MF 0.022 $\mu$ F $\pm 10\%$ [for ZS]	50V	R107	0113663	CF 100K $\Omega$ $\pm 5\%$	SRD1/6P	R223	0113591	CF 100 $\Omega$ $\pm 5\%$	SRD1/6P
C812	0244173	CD 0.022 $\mu$ F $\pm 80\%$ [for ZS]	50V	R108	0129551	CF 68 $\Omega$ $\pm 5\%$	SRD1/4P	R224	0113627	CF 3.3K $\Omega$ $\pm 5\%$	SRD1/6P
C901LR	0240045	CC 1000PF $\pm 10\%$	50V	R108	0129565	CF 150 $\Omega$ $\pm 5\%$	SRD1/4P	R225	0113647	CF 22K $\Omega$ $\pm 5\%$	SRD1/6P
C902LR	0240051	CC 1500PF $\pm 10\%$	50V	R109	0113591	CF 100 $\Omega$ $\pm 5\%$	SRD1/6P	R226	0113663	CF 100K $\Omega$ $\pm 5\%$	SRD1/6P
C903LR	0240039	CC 330PF $\pm 10\%$	50V	R151	0113639	CF 10K $\Omega$ $\pm 5\%$	SRD1/6P	R229	1119425	MO 220 $\Omega$ $\pm 10\%$	RS1B
C904LR	0240039	CC 330PF $\pm 10\%$	50V	R152	0113639	CF 10K $\Omega$ $\pm 5\%$	SRD1/6P	R229	1119425	MO 220 $\Omega$ $\pm 10\%$	RS1B
C905LR	0252231	EL 100 $\mu$ F	6.3V	R153	0113663	CF 100K $\Omega$ $\pm 5\%$	SRD1/6P	R301	0129577	CF 470 $\Omega$ $\pm 5\%$	SRD1/4P
C906LR	0240219	CD 0.039 $\mu$ F $\pm 10\%$	25V	R154	0113663	CF 220K $\Omega$ $\pm 5\%$	SRD1/6P	R301	0129583	CF 820 $\Omega$ $\pm 5\%$	SRD1/4P
C907	0252522	EL 22 $\mu$ F	16V	R155	0113663	CF 100K $\Omega$ $\pm 5\%$	SRD1/6P	R302	0113635	CF 6.8K $\Omega$ $\pm 5\%$	SRD1/6P
C908	0252525	EL 47 $\mu$ F	16V	R156	0113623	CF 2.2K $\Omega$ $\pm 5\%$	SRD1/6P	R303	0113615	CF 1K $\Omega$ $\pm 5\%$	SRD1/6P
C909LR	0240066	CC 0.022 $\mu$ F $\pm 80\%$	16V	R157	0113671	CF 220K $\Omega$ $\pm 5\%$	SRD1/6P	R304	0113633	CF 5.6K $\Omega$ $\pm 5\%$	SRD1/6P
C910LR	0252813	EL 3.3 $\mu$ F	50V	R158	0113631	CF 4.7K $\Omega$ $\pm 5\%$	SRD1/6P	R304	0113635	CF 6.8K $\Omega$ $\pm 5\%$	SRD1/6P
C911	0252522	EL 22 $\mu$ F	16V	R159	0113652	CF 1K $\Omega$ $\pm 5\%$	SRD1/2P	R304	0113635	CF 6.8K $\Omega$ $\pm 5\%$	SRD1/6P
C912LR	0252813	EL 3.3 $\mu$ F	50V	R201	0113603	CF 330 $\Omega$ $\pm 5\%$	SRD1/6P	R305	0113633	CF 5.6K $\Omega$ $\pm 5\%$	SRD1/6P
C913LR	0240045	CC 1000PF $\pm 10\%$	50V	R202	0113603	CF 330 $\Omega$ $\pm 5\%$	SRD1/6P	R305	0113635	CF 6.8K $\Omega$ $\pm 5\%$	SRD1/6P
C914LR	0240053	CC 2200PF $\pm 20\%$	16V	R203	0113615	CF 1K $\Omega$ $\pm 5\%$	SRD1/6P	R305	0113635	CF 6.8K $\Omega$ $\pm 5\%$	SRD1/6P
C915LR	0252813	EL 3.3 $\mu$ F	50V	R203	0113623	CF 2.2K $\Omega$ $\pm 5\%$	SRD1/6P	R306	0113631	CF 4.7K $\Omega$ $\pm 5\%$	SRD1/6P
C916	02525312	EL 100 $\mu$ F	16V	R204	0113605	CF 390 $\Omega$ $\pm 5\%$	SRD1/6P	R307	0113631	CF 4.7K $\Omega$ $\pm 5\%$	SRD1/6P
C917	02525312	EL 100 $\mu$ F	16V	R205	0113619	CF 1.5K $\Omega$ $\pm 5\%$	SRD1/6P	R308	0113613	CF 820 $\Omega$ $\pm 5\%$	SRD1/6P
C918LR	0252813	EL 3.3 $\mu$ F	50V	R206	0113639	CF 10K $\Omega$ $\pm 5\%$	SRD1/6P	R308	0113607	CF 470 $\Omega$ $\pm 5\%$	SRD1/6P
C919LR	0252813	EL 3.3 $\mu$ F	50V					R308	0113605	CF 390 $\Omega$ $\pm 5\%$	SRD1/6P
C920LR	02528072	EL 0.68 $\mu$ F	50V					R309	0113663	CF 100K $\Omega$ $\pm 5\%$	SRD1/6P
C921	0240061	CC 0.01 $\mu$ F $\pm 30\%$	16V					R311	0113663	CF 100K $\Omega$ $\pm 5\%$	SRD1/6P
C928LR	0240218	CD 0.033 $\mu$ F $\pm 10\%$	25V								
C929LR	0240039	CC 330PF $\pm 10\%$	50V								
C930LR	0240215	CD 0.018 $\mu$ F $\pm 10\%$	25V								
C931LR	0240216	CD 0.022 $\mu$ F $\pm 10\%$	25V								
C933LR	0240216	CD 0.022 $\mu$ F $\pm 10\%$	25V								
C934LR	0240037	CC 220PF $\pm 10\%$	50V								
C936LR	0252813	EL 3.3 $\mu$ F	50V								

SYMBOL No.	PART No.	DESCRIPTION	SYMBOL No.	PART No.	DESCRIPTION	SYMBOL No.	PART No.	DESCRIPTION
R315	0113647	CF 22K $\Omega$ $\pm$ 5% SRD1/6P [for ZS]	R520	0113639	CF 10K $\Omega$ $\pm$ 5% SRD1/6P	R704LR	0129611	CF 2.7K $\Omega$ $\pm$ 5% SRD1/4P [except BS]
R316	0113665	CF 120K $\Omega$ $\pm$ 5% SRD1/6P [except ZS]	R521	0113639	CF 10K $\Omega$ $\pm$ 5% SRD1/6P [for EW]	R705LR	0129609	CF 2.2K $\Omega$ $\pm$ 5% SRD1/4P [for BS]
R316	0113669	CF 180K $\Omega$ $\pm$ 5% SRD1/6P [for ZS]	R525	0113623	CF 2.2K $\Omega$ $\pm$ 5% SRD1/6P	R705LR	0129611	CF 2.7K $\Omega$ $\pm$ 5% SRD1/4P [except BS]
R317	0113631	CF 4.7K $\Omega$ $\pm$ 5% SRD1/6P	R526	0113623	CF 2.2K $\Omega$ $\pm$ 5% SRD1/6P	R706LR	0113663	CF 100K $\Omega$ $\pm$ 5% SRD1/6P
R318	0113651	CF 33K $\Omega$ $\pm$ 5% SRD1/6P	R527	0113659	CF 68K $\Omega$ $\pm$ 5% SRD1/6P	$\Delta$ R707	1110621	FR 100 $\Omega$ $\pm$ 5% RN1/4B
R319	0113611	CF 680 $\Omega$ $\pm$ 5% SRD1/6P [for ZS]	R528	0113623	CF 2.2K $\Omega$ $\pm$ 5% SRD1/6P	R708	0129601	CF 1K $\Omega$ $\pm$ 5% SRD1/4P
			R529	0113655	CF 47K $\Omega$ $\pm$ 5% SRD1/6P	R709	0129617	CF 4.7K $\Omega$ $\pm$ 5% SRD1/4P
			R530	0113655	CF 47K $\Omega$ $\pm$ 5% SRD1/6P			
			R531	0113655	CF 47K $\Omega$ $\pm$ 5% SRD1/6P	$\Delta$ R710	1110621	FR 100 $\Omega$ $\pm$ 5% RN1/4B
R319	0113615	CF 1K $\Omega$ $\pm$ 5% SRD1/6P [except ZS]	R532	0113291	CF 220 $\Omega$ $\pm$ 5% SRD1/2P	R711LR	1119029	ME 4.7 $\Omega$ $\pm$ 10% RN1B
R401LR	0113685	CF 820 $\Omega$ $\pm$ 5% SRD1/6P [for BS]	R533	0113293	CF 330 $\Omega$ $\pm$ 5% SRD1/2P	R712LR	1119427	ME 330 $\Omega$ $\pm$ 10% RN1B [for BS]
R401LR	0113623	CF 2.2K $\Omega$ $\pm$ 5% SRD1/6P [except BS]	R534	0113667	CF 150K $\Omega$ $\pm$ 5% SRD1/6P	R712LR	0119527	ME 330 $\Omega$ $\pm$ 10% RN2B [except BS]
R402LR	0113655	CF 47K $\Omega$ $\pm$ 5% SRD1/6P	R535	0113615	CF 1K $\Omega$ $\pm$ 5% SRD1/6P	R751	0113665	CF 120K $\Omega$ $\pm$ 5% SRD1/6P
R403LR	0113621	CF 1.8K $\Omega$ $\pm$ 5% SRD1/6P [except BS]	R536	0113615	CF 1K $\Omega$ $\pm$ 5% SRD1/6P	R752	0113665	CF 120K $\Omega$ $\pm$ 5% SRD1/6P
R403LR	0113625	CF 2.7K $\Omega$ $\pm$ 5% SRD1/6P [for BS]	R537	0113575	CF 22 $\Omega$ $\pm$ 5% SRD1/6P	R753	0113663	CF 100K $\Omega$ $\pm$ 5% SRD1/6P
			R538	0113657	CF 56K $\Omega$ $\pm$ 5% SRD1/6P	R754	0113615	CF 1K $\Omega$ $\pm$ 5% SRD1/6P
			R539	01132872	CF 100 $\Omega$ $\pm$ 5% SRD1/2P [except BS]	R755	0113663	CF 100K $\Omega$ $\pm$ 5% SRD1/6P
R404LR	0113645	CF 18K $\Omega$ $\pm$ 5% SRD1/6P [for BS]	R539	0129565	CF 150 $\Omega$ $\pm$ 5% SRD1/4P [for BS]	R756	0129617	CF 4.7K $\Omega$ $\pm$ 5% SRD1/4P [for BS]
R404LR	0113677	CF 390K $\Omega$ $\pm$ 5% SRD1/6P [except BS]	R540	01132872	CF 100 $\Omega$ $\pm$ 5% SRD1/2P [except BS]	R756	0129631	CF 10K $\Omega$ $\pm$ 5% SRD1/4P [except BS]
R405LR	0113651	CF 33K $\Omega$ $\pm$ 5% SRD1/6P [except BS]	R540	0129565	CF 150 $\Omega$ $\pm$ 5% SRD1/4P [for BS]	R757	0113635	CF 6.8K $\Omega$ $\pm$ 5% SRD1/6P [for BS]
R406LR	0113647	CF 22K $\Omega$ $\pm$ 5% SRD1/6P [except BS]	R541	0113663	CF 100K $\Omega$ $\pm$ 5% SRD1/6P [DISPLAY P.W.B.]	R757	0113647	CF 22K $\Omega$ $\pm$ 5% SRD1/6P [except BS]
R407LR	0113645	CF 18K $\Omega$ $\pm$ 5% SRD1/6P	R541	0113639	CF 10K $\Omega$ $\pm$ 5% SRD1/6P [AUDIO P.W.B.]	R758	0110131	MO 270 $\Omega$ $\pm$ 5% RS1B
R408LR	0113661	CF 82K $\Omega$ $\pm$ 5% SRD1/6P [for BS]	R542	0113655	CF 47K $\Omega$ $\pm$ 5% SRD1/6P	R759	0110131	MO 270 $\Omega$ $\pm$ 5% RS1B [except BS]
			R543	0113639	CF 10K $\Omega$ $\pm$ 5% SRD1/6P [for BS, ES]	$\Delta$ R801	1113823	FR 3.3 $\Omega$ $\pm$ 5% RN1B [for BS]
R408LR	0113647	CF 22K $\Omega$ $\pm$ 5% SRD1/6P [except BS]	R544	0113667	CF 150K $\Omega$ $\pm$ 5% SRD1/6P [for BS, ES]	R801	1119155	ME 22 $\Omega$ $\pm$ 10% RN2B [except BS]
R409	0113635	CF 6.8K $\Omega$ $\pm$ 5% SRD1/6P	R545	0113663	CF 100K $\Omega$ $\pm$ 5% SRD1/6P	R802	0129581	CF 680 $\Omega$ $\pm$ 5% SRD1/4P [for BS]
R410	0113639	CF 10K $\Omega$ $\pm$ 5% SRD1/6P	R546	0113623	CF 2.2K $\Omega$ $\pm$ 5% SRD1/6P	R802	0129617	CF 4.7K $\Omega$ $\pm$ 5% SRD1/4P [except BS]
R451	0113623	CF 2.2K $\Omega$ $\pm$ 5% SRD1/6P	R547	0113633	CF 5.6K $\Omega$ $\pm$ 5% SRD1/6P			
R452	0113639	CF 10K $\Omega$ $\pm$ 5% SRD1/6P	R548	0113623	CF 2.2K $\Omega$ $\pm$ 5% SRD1/6P			
R499	0113631	CF 4.7K $\Omega$ $\pm$ 5% SRD1/6P	R551	0113623	CF 2.2K $\Omega$ $\pm$ 5% SRD1/6P [for BS]			
R501	0113623	CF 2.2K $\Omega$ $\pm$ 5% SRD1/6P	R551	0113627	CF 3.3K $\Omega$ $\pm$ 5% SRD1/6P [except BS]	R803	0129613	CF 3.3K $\Omega$ $\pm$ 5% SRD1/4P [for BS]
R502	0113611	CF 680 $\Omega$ $\pm$ 5% SRD1/6P	R552	0113631	CF 4.7K $\Omega$ $\pm$ 5% SRD1/6P	R803	0129601	CF 1K $\Omega$ $\pm$ 5% SRD1/4P [except BS]
R503	0113631	CF 4.7K $\Omega$ $\pm$ 5% SRD1/6P	R561	0113663	CF 100K $\Omega$ $\pm$ 5% SRD1/6P [for EW]	R805	0129581	CF 680 $\Omega$ $\pm$ 5% SRD1/4P [for BS]
			R562	0113639	CF 10K $\Omega$ $\pm$ 5% SRD1/6P [for EW]	R805	0129617	CF 4.7K $\Omega$ $\pm$ 5% SRD1/4P [except BS]
R504	0113635	CF 6.8K $\Omega$ $\pm$ 5% SRD1/6P	R563	0113655	CF 47K $\Omega$ $\pm$ 5% SRD1/6P [for EW]	$\Delta$ R806	1110601	ME 10 $\Omega$ $\pm$ 5% RN1/4B [for BS]
R505	0113635	CF 6.8K $\Omega$ $\pm$ 5% SRD1/6P [for BS, ES]	R651LR	0113627	CF 3.3K $\Omega$ $\pm$ 5% SRD1/6P	$\Delta$ R806	1110625	FR 220 $\Omega$ $\pm$ 5% RN1/4B [except BS]
R506	0113635	CF 10K $\Omega$ $\pm$ 5% SRD1/6P [for BS, ES]	R652LR	0113627	CF 3.3K $\Omega$ $\pm$ 5% SRD1/6P	R807	0129577	CF 470 $\Omega$ $\pm$ 5% SRD1/4P [for BS]
R507	0113639	CF 1K $\Omega$ $\pm$ 5% SRD1/6P [for BS, ES]	R653LR	0113631	CF 4.7K $\Omega$ $\pm$ 5% SRD1/6P	R807	0129601	CF 1K $\Omega$ $\pm$ 5% SRD1/4P [except BS]
R508	0113635	CF 6.8K $\Omega$ $\pm$ 5% SRD1/6P [for BS, ES]	R654LR	0113643	CF 15K $\Omega$ $\pm$ 5% SRD1/6P	$\Delta$ R809	1110601	FR 10 $\Omega$ $\pm$ 5% RN1/4B [except BS]
R509	0113639	CF 10K $\Omega$ $\pm$ 5% SRD1/6P	R701LR	0113623	CF 2.2K $\Omega$ $\pm$ 5% SRD1/6P	$\Delta$ R810	1110601	FR 10 $\Omega$ $\pm$ 5% RN1/4B [except BS]
R510	0113639	CF 10K $\Omega$ $\pm$ 5% SRD1/6P	R702LR	0113663	CF 100K $\Omega$ $\pm$ 5% SRD1/6P			
R511	0113639	CF 10K $\Omega$ $\pm$ 5% SRD1/6P	R703LR	0113613	CF 820 $\Omega$ $\pm$ 5% SRD1/6P [for BS]			
R512	0113639	CF 10K $\Omega$ $\pm$ 5% SRD1/6P	R703LR	0113605	CF 390 $\Omega$ $\pm$ 5% SRD1/6P [except BS]			
R513	0113639	CF 10K $\Omega$ $\pm$ 5% SRD1/6P	R704LR	0129609	CF 2.2K $\Omega$ $\pm$ 5% SRD1/4P [for BS]			
R514	0113653	CF 39K $\Omega$ $\pm$ 5% SRD1/6P						
R515	0113653	CF 39K $\Omega$ $\pm$ 5% SRD1/6P						
R516	0113653	CF 39K $\Omega$ $\pm$ 5% SRD1/6P						
R517	0113653	CF 39K $\Omega$ $\pm$ 5% SRD1/6P						
R518	0113653	CF 39K $\Omega$ $\pm$ 5% SRD1/6P						
R519	0113653	CF 39K $\Omega$ $\pm$ 5% SRD1/6P						

SYMBOL No.	PART No.	DESCRIPTION	SYMBOL No.	PART No.	DESCRIPTION	SYMBOL No.	PART No.	DESCRIPTION
R902LR	0113661	CF 82K $\Omega$ $\pm$ 5% SRD1/6P	R967LR	0113657	CF 56K $\Omega$ $\pm$ 5% SRD1/6P	Q509	2318303	2SC1740S(S) [for EW]
R903LR	0113627	CF 3.3K $\Omega$ $\pm$ 5% SRD1/6P	R968	0113639	CF 10K $\Omega$ $\pm$ 5% SRD1/6P	Q510	0573486	2SC460B
R904	0113625	CF 2.7K $\Omega$ $\pm$ 5% SRD1/6P	R969	0113639	CF 10K $\Omega$ $\pm$ 5% SRD1/6P	Q511	2329183	2SA1015(GR)
R905LR	0113623	CF 2.2K $\Omega$ $\pm$ 5% SRD1/6P	R971	1119425	MO 220 $\Omega$ $\pm$ 10% RS1B	Q512	2329183	2SA1015(GR)
R906LR	0113627	CF 3.3K $\Omega$ $\pm$ 5% SRD1/6P	R972	0113641	CF 12K $\Omega$ $\pm$ 5% SRD1/6P	Q513	2329183	2SA1015(GR)
R907	0113651	CF 33K $\Omega$ $\pm$ 5% SRD1/6P	R973	0113647	CF 22K $\Omega$ $\pm$ 5% SRD1/6P	Q514	2329183	2SA1015(GR) [for BS, ES]
R908LR	0113637	CF 8.2K $\Omega$ $\pm$ 5% SRD1/6P	R991	0113649	CF 27K $\Omega$ $\pm$ 5% SRD1/6P	Q515	2329183	2SA1015(GR) [for BS, ES]
R909LR	0113643	CF 15K $\Omega$ $\pm$ 5% SRD1/6P	R992	0113567	CF 10 $\Omega$ $\pm$ 5% SRD1/6P	Q801	2317822	2SD880(Y)
R910LR	0113639	CF 10K $\Omega$ $\pm$ 5% SRD1/6P	R994	0113639	CF 10K $\Omega$ $\pm$ 5% SRD1/6P	Q802	2318303	2SC1740S(S)
R911	0113639	CF 10K $\Omega$ $\pm$ 5% SRD1/6P	R995	0113665	CF 120K $\Omega$ $\pm$ 5% SRD1/6P	Q803	2328625	2SB647C
R912	0113651	CF 33K $\Omega$ $\pm$ 5% SRD1/6P	R996	0113651	CF 33K $\Omega$ $\pm$ 5% SRD1/6P [for BS, ES]	Q901LR	2318303	2SC1740S(S)
R913LR	0113639	CF 10K $\Omega$ $\pm$ 5% SRD1/6P	R997	0113663	CF 100K $\Omega$ $\pm$ 5% SRD1/6P [for BS, ES]	Q902	2318303	2SC1740S(S)
R914LR	0113639	CF 10K $\Omega$ $\pm$ 5% SRD1/6P	ICs & TRANSISTORS			Q903LR	2318303	2SC1740S(S)
R915	0113651	CF 33K $\Omega$ $\pm$ 5% SRD1/6P	IC201	23684312	AN278	Q905LR	2318303	2SC1740S(S)
R916	0113639	CF 10K $\Omega$ $\pm$ 5% SRD1/6P	IC202	23004122	LA1265	Q906LR	2318303	2SC1740S(S)
R917LR	0113627	CF 3.3K $\Omega$ $\pm$ 5% SRD1/6P	IC301	23005612	LA3361	Q907LR	2318303	2SC1740S(S)
R918LR	0113623	CF 2.2K $\Omega$ $\pm$ 5% SRD1/6P	IC401	2388302	BA4558HT	Q908LR	2318303	2SC1740S(S)
R919LR	0113663	CF 100K $\Omega$ $\pm$ 5% SRD1/6P	IC402	2387564	TC9152P	Q910	2318303	2SC1740S(S)
R920	0113639	CF 10K $\Omega$ $\pm$ 5% SRD1/6P	IC501	23008612	$\mu$ PD1713AG-015	Q911	2318303	2SC1740S(S)
R921LR	0113633	CF 5.6K $\Omega$ $\pm$ 5% SRD1/6P	IC502	2387611	BA6251	Q912	2318303	2SC1740S(S)
R922	0113639	CF 10K $\Omega$ $\pm$ 5% SRD1/6P	IC651LR	23008412	BA3812L	Q913	2318303	2SC1740S(S)
R923	0113654	CF 43K $\Omega$ $\pm$ 5% SRD1/6P	IC701	2301751	STK4112 II [for BS]	Q914	2318303	2SC1740S(S)
R924LR	0113653	CF 39K $\Omega$ $\pm$ 5% SRD1/6P	IC701	2301161	STK4142 II [except BS]	Q915	2329183	2SA1015(GR)
R925LR	0113647	CF 22K $\Omega$ $\pm$ 5% SRD1/6P	IC751	2387582	$\mu$ PC1237HA	Q916LR	2329952	2SD655(E)
R926	0113631	CF 4.7K $\Omega$ $\pm$ 5% SRD1/6P	IC901	23010522	BA3416BL	Q917	2318303	2SC1740S(S)
R927	0113657	CF 56K $\Omega$ $\pm$ 5% SRD1/6P	IC902	2388302	BA4558HT	Q991	2317782	2SC2235(Y)
R928LR	0113635	CF 6.8K $\Omega$ $\pm$ 5% SRD1/6P	IC903	23020912	CXA1101	Q992	2329952	2SD655(E) [for BS, ES]
R929LR	0113631	CF 4.7K $\Omega$ $\pm$ 5% SRD1/6P	IC904	2388302	BA4558HT	DIODES		
R930LR	0113641	CF 12K $\Omega$ $\pm$ 5% SRD1/6P	IC981	2387051	LB1403	D101	23376012	1S2473
R931LR	0113639	CF 10K $\Omega$ $\pm$ 5% SRD1/6P	Q101	2318303	2SC1740S(S) [for ZS]	D102	23376012	1S2473
R932LR	0113619	CF 1.5K $\Omega$ $\pm$ 5% SRD1/6P	Q102	2328803	2SK104(H) [for ZS]	D103	2337931	1K60R [for ZS]
R933LR	0113583	CF 47 $\Omega$ $\pm$ 5% SRD1/6P	Q151	2318303	2SC1740S(S) [for BS, ES]	D104	2337931	1K60R [for ZS]
R935LR	0113625	CF 2.7K $\Omega$ $\pm$ 5% SRD1/6P	Q152	2318303	2SC1740S(S) [for BS, ES]	D151	23376012	1S2473
R938LR	0113627	CF 3.3K $\Omega$ $\pm$ 5% SRD1/6P	Q201	2318303	2SC1740S(S)	D152	23376012	1S2473
R939	0113639	CF 10K $\Omega$ $\pm$ 5% SRD1/6P	Q202	2318303	2SC1740S(S)	D153	2397321	KV1260
R942	0113667	CF 150K $\Omega$ $\pm$ 5% SRD1/6P	Q203	2318303	2SC1740S(S)	D154	2397321	KV1260 [for BS, ES]
R944	0113639	CF 10K $\Omega$ $\pm$ 5% SRD1/6P	Q301	2318303	2SC1740S(S)	D155	23376012	1S2473 [for BS, ES]
R945	0113639	CF 10K $\Omega$ $\pm$ 5% SRD1/6P	Q302	2318303	2SC1740S(S)	D156	23376012	1S2473 [for BS, ES]
R946	0113639	CF 10K $\Omega$ $\pm$ 5% SRD1/6P	Q303	2329183	2SA1015(GR)	D157	23376012	1S2473 [for BS, ES]
R947	0113663	CF 100K $\Omega$ $\pm$ 5% SRD1/6P	Q304	2318303	2SC1740S(S)	D158	23376012	1S2473 [for BS, ES]
R948	0113633	CF 5.6K $\Omega$ $\pm$ 5% SRD1/6P	Q501	2318303	2SC1740S(S)	D159	23376012	1S2473 [for BS, ES]
R949	0113665	CF 120K $\Omega$ $\pm$ 5% SRD1/6P	Q502	2318303	2SC1740S(S)	D455	23376012	1S2473
R950	0113617	CF 1.2K $\Omega$ $\pm$ 5% SRD1/6P	Q503	2318303	2SC1740S(S) [for BS, ES]	D456	23376012	1S2473
R951	0113647	CF 22K $\Omega$ $\pm$ 5% SRD1/6P	Q504	2318303	2SC1740S(S) [for BS, ES]	D457	23376012	1S2473
R952	0113647	CF 22K $\Omega$ $\pm$ 5% SRD1/6P	Q505	2318303	2SC1740S(S)	D501	23376012	1S2473
R953	0113647	CF 22K $\Omega$ $\pm$ 5% SRD1/6P	Q506	2329183	2SA1015(GR)	D502	23376012	1S2473
R954	0113639	CF 10K $\Omega$ $\pm$ 5% SRD1/6P	Q507	2329183	2SA1015(GR)	D503	23376012	1S2473
R955	01132922	CF 270 $\Omega$ $\pm$ 5% SRD1/2P [for BS]	Q508	2329183	2SA1015(GR) [for EW]	D504	23376012	1S2473
R955	0113293	CF 330 $\Omega$ $\pm$ 5% SRD1/2P [except BS]				D505	23376012	1S2473
R956	01132912	CF 220 $\Omega$ $\pm$ 5% SRD1/2P [for BS]						
R956	0113293	CF 330 $\Omega$ $\pm$ 5% SRD1/2P [except BS]						
R959	0113639	CF 10K $\Omega$ $\pm$ 5% SRD1/6P						
R960LR	0113669	CF 180K $\Omega$ $\pm$ 5% SRD1/6P						
R962LR	0113647	CF 22K $\Omega$ $\pm$ 5% SRD1/6P						
R963	0113639	CF 10K $\Omega$ $\pm$ 5% SRD1/6P						
R964	0113663	CF 100K $\Omega$ $\pm$ 5% SRD1/6P						
R965	0113639	CF 10K $\Omega$ $\pm$ 5% SRD1/6P						
R966	0113657	CF 56K $\Omega$ $\pm$ 5% SRD1/6P						





SYMBOL No.	PART No.	DESCRIPTION	SYMBOL No.	PART No.	DESCRIPTION	SYMBOL No.	PART No.	DESCRIPTION
D506	23376012	1S2473	VARIABLE RESISTORS			S514	2639682	Tact switch (TUNING UP)
D507	23376012	1S2473	RT301	0150958	10kΩ-(B) (FM MPX VCO ADJ.)	S515	2639682	Tact switch (LW) [for BS, ES]
D508	23376012	1S2473	RT901LR	0158928	100kΩ-(B) (BIAS ADJ.)	S516	2639682	Tact switch (+10)
D509	23376012	1S2473	RT902	0158922	1kΩ-(B) (TAPE SPEED ADJ.)	S517	2639682	Tact switch (P10)
D510	23376012	1S2473	RV651	0167001	100kΩ-(B) (G.E CONTROL)	S518	2639682	Tact switch (P9)
D511	23376012	1S2473	RV652	0167001	100kΩ-(B) (G.E CONTROL)	S519	2629381	Slide switch [AM SPACING] [for EW]
D512	23376012	1S2473 [except US, CS, SA]	RV653	0167001	100kΩ-(B) (G.E CONTROL)	S901	2628983	Slide switch (REC/PLAY SELECT)
D513	23376012	1S2473	RV654	0167001	100kΩ-(B) (G.E CONTROL)	S902	2600562	2 key push switch (TAPE SELECT)
D514	23376012	1S2473 [except US, CS]	RV655	0167001	100kΩ-(B) (G.E CONTROL)	S903	2600561	2 key push switch (DOLBY NR/DUBBING SPEED SELECT)
D515	23376012	1S2473	RV656	0167002	250kΩ (BALANCE CONTROL)	S991	2629381	Slide switch (RIF) [for BS, ES]
D516	23376012	1S2473	RV657	0158781	100kΩ-(B) (VOLUME CONTROL)	CP101	2137301	FM band-pass filter [for ZS]
D517	23376012	1S2473	RV901	0150701	10kΩ-(B) (REC. LEVEL CONTROL)	CP301	2136313	Low pass filter [for ZS]
D518	23376012	1S2473	COILS & TRANSFORMERS			△F001	2727964	Fuse 2.5A 125V [for US, CS]
D519	23376012	1S2473	L151	2137373	AM ANT. coil (MW)	△F001	2727738	Fuse T400mA [for BS]
D551	2398781	11E2	L152	2136493	AM OSC. coil	△F001	2727191	Fuse T1A 250V [except US, CS, BS]
D751	23371512	1S2076A	L153	2137374	AM ANT. coil (LW) [for BS, ES]	△F801	2727893	Fuse 2A 125V [for US, CS]
D752	2398781	11E2	L154	2136494	LW OSC. coil [for BS, ES]	△F801	2727745	Fuse T2A 250V [for BS]
D801	2338162	S2VB20 [for BS]	L901LR	2227991	Choke coil 3.3MH	△F801	2727193	Fuse T2A 250V [except US, CS, BS]
D801	2337461	S4VB20 [except BS]	L902LR	2228003	Choke coil 22mH	△F802	2727898	Fuse 800mA 125V [for US, CS]
D802	2398781	11E2	L991	2136823	Bias OSC. coil	△F802	2727730	Fuse T630mA 250V [for BS]
D803	2398781	11E2	LC901LR	2228103	Dolby filter	△F802	2727195	Fuse T630mA 250V [except US, CS, BS]
D901	23376012	1S2473	T201	2137033	FM discriminator coil	△F803	2727898	Fuse 800mA 125V [for US, CS]
D902	23376012	1S2473	T202	2154493	AM IF transformer	△F803	2727730	Fuse T630mA 250V [for BS]
D903	23376012	1S2473	MISCELLANEOUS			△F803	2727195	Fuse T630mA 250V [except US, CS, BS]
D904	23376012	1S2473	AT101	2689552	Antenna terminal	FE101	2405031	FM tuner pack [except ZS]
D905	23376012	1S2473	JK701	2689551	4P push terminal	FE101	2405041	FM tuner pack [for ZS]
D906	23376012	1S2473	JK702	2677863	Headphones jack	P401	2678921	4P US pin jack [except BS]
D907	23376012	1S2473	MF201	2135002	Ceramic filter	P401	2678151	Pin jack [for BS]
D908	23376012	1S2473	MF202	2135002	Ceramic filter [for ZS]	3909371	LCD holder	
D912	23376012	1S2473	MF203	2135002	Ceramic filter	for Accessories		
ZD501	23375242	HZ9B1	MF204	2155152	AM ceramic filter	△	2758342	AM loop antenna
ZD502	2337121	HZ6A	RY701	2647761	DC relay		2757528	FM antenna [for US, CS, SA]
ZD551	2339657	HZ5C-1	X501	2785302	Crystal		2667922	Siemens plug [for EW]
ZD801	2337189	HZ-15-3 [except BS]	LCD1	2780081	Liquid crystal display			
ZD801	2337564	HZ12-B1 [for BS]	△S001	2600551	Power switch			
ZD802	2337189	HZ-15-3 [except BS]	△S002	2618053	Voltage switch (VOLTAGE SELECT) [for EW]			
ZD802	2337564	HZ12-B1 [for BS]	S451	2639682	Tact switch (TAPE)			
ZD901	2337613	HZ-3A-3	S452	2639682	Tact switch (PHONO)			
ZD902	23371222	HZ-6B	S453	2639682	Tact switch (CD)			
LED451	23391022	SLP-160C	S454	2639682	Tact switch (TUNER)			
LED452	23391022	SLP-160C	S501	2639682	Tact switch (FM)			
LED453	23391022	SLP-160C	S502	2639682	Tact switch (AUTO)			
LED454	23391022	SLP-160C	S503	2639682	Tact switch (P4)			
LED981	2398401	SLR-54DC5	S504	2639682	Tact switch (P3)			
LED982	2398401	SLR-54DC5	S505	2639682	Tact switch (P2)			
LED983	2398401	SLR-54DC5	S506	2639682	Tact switch (P1)			
LED984	23391022	SLP-160C	S507	2639682	Tact switch (MW)			
LED985	23391022	SLP-160C	S508	2639682	Tact switch (MEMORY)			
LED551-555	2398453	LED	S509	2639682	Tact switch (P8)			
			S510	2639682	Tact switch (P7)			
			S511	2639682	Tact switch (P6)			
			S512	2639682	Tact switch (P5)			
			S513	2639682	Tact switch (TUNING DOWN)			

SYMBOL No.	PART No.	DESCRIPTION	SYMBOL No.	PART No.	DESCRIPTION	SYMBOL No.	PART No.	DESCRIPTION
<b>CABINET CHASSIS</b>			△41	2749582	Power supply cord [for BS]	28	4858367	Washer
1	4479031	Top cover	△	2749622	Power supply cord [for SA]	29	4835716	Spring
2	8679608	4 φ x 8 DT screw	△	2718091	Power supply cord [for ZS]	30	4835717	Spring
3	8679406	3 φ x 6 DT screw	△	2707709	Power supply cord [for ES]	31	4835718	Spring
4	40457712	Cassette door (1) assy	△	2706584	Power supply cord [for EW]	32	4835719	Steel crammer
5	40457722	Cassette door (2) assy	△42	2267461	Power transformer [for US, CS]	33	4835721	Spring
6	3309082	Power button	△	2267462	Power transformer [for SA]	34	4835723	Pendulum
7	86914102	3 φ x 10 BT screw	△	2267463	Power transformer [for ES, ZS]	35	4835724	Belt
8	3307203	Push button	△	2267464	Power transformer [for EW]	36	4835725	Rubber tube
9	3309161	REC VOL. knob	△	2267491	Power transformer [for BS]	37	4835726	Rubber foot (L)
10	3309131	VOL. knob	43	8671608	4 φ x 8 DT screw	39	4817549	Washer
11	3309141	Function button	44	2677911	Socket (FM 75)	40	4835729	Washer
12	3309091	EQ knob		2658391	DIN antenna socket [for ZS]	41	4817557	E ring
14	3309121	Tuning button	△45	3913006	Bushing [except EW]	42	4858373	Oil shaft
15	3309111	Band change button [for US, CS, ZS, EW]	△	0043793	Bushing [for EW]	43	4858371	Screw
	3309112	Band change button [for BS, ES, SA]	46	4567412	3 φ x 8 DT bind screw (heat sink) [except BS]	44	4835736	Steel ball
16	40457212	Front panel assy [for US, CS, ZS, EW]	47	8671414	3 φ x 14 DT screw (IC701)	45	4858372	Screw
	40457222	Front panel assy [for BS, ES, SA]	<b>TURNTABLE SECTION (HT-MD30/MD30X)</b>			46	4835737	Cam gear assy
17	3950381	Damper assy	1	4817521	45RPM adaptor	47	4835738	Platter assy
18	2588921	Counter	2	4835665	Starting lever	48	4835739	Return link assy
19	4479061	Rear plate [for US]	3	4835668	Knob shaft	49	4835730	Pick up stand assy
	4479062	Rear plate [for CS]	4	4835669	Oil shaft	50	4835741	Tone arm assy [for HT-MD30]
	4479063	Rear plate [for ES]	5	4835660	Press set	50	4839911	Tone arm assy [for HT-MD30X]
	4479064	Rear plate [for BS]	6	4835671	Lifter	51	4835745	Dust cover assy
	4479065	Rear plate [for SA]	7	4835675	Pendulum set	52	4859281	Player base assy [for HT-MD30]
	4479066	Rear plate [for ZS]	8	3307471	Push button		4859291	Player base assy [for HT-MD30X]
	4479067	Rear plate [for EW]	9	3307461	Push button	53	4835743	Motor assy
20	86994102	3 φ x 10 BT screw	10	3802391	Bottom plate	54	4835695	5P connector assy
21	86714062	3 φ x 6 bind tapping screw	11	4835676	Platter shaft assy	55	4835731	Washer
22	4597971	PT screw	12	4835670	Press plate	<b>CASSETTE CHASSIS</b>		
23	3927411	Foot	13	4835681	Hanging plate for motor	1	48189922	Switch plate
24	8671410	3 φ x 10 DT screw	14	4835682	Pendulum	2	4839371	Push button actuator assy
25	8671414	3 φ x 14 DT screw	15	4835683	Hinge assy	3	4823651	REC button lever
26	8671408	3 φ x 8 DT screw	16	4835693	Micro switch	4	4823661	PLAY button lever
27	2589323	TN-21SW-985 deck mecha	17	4835694	Push switch	5	4823671	RWD button lever
28	46919112	Counter belt	18	4835696	PC board	6	4823681	FF button lever
29	4475821	Eject spring	19	4835697	PC board	7	4823691	STOP button lever
30	4475831	Eject spring	20	4835703	Screw	8	4823701	PAUSE button lever assy
31	3309181	D operation button	21	4835704	Screw	9	48189902	RWD lever
32	3309171	D operation button	22	4835706	Screw	10	4833451	PAUSE lever
33	3309172	D operation button	23	4835707	Screw	11	48191322	PAUSE lever spring
34	3309173	D operation button	24	4835708	Screw	12	48191332	PAUSE stopper
35	3309174	D operation button	25	4835700	Screw	13	4850692	Button lever spring (K)
36	3309175	D operation button	26	4835712	Screw	14	48190072	Button lever spring (A)
37	3309176	D operation button	27	4835713	Screw	15	48202172	PLAY button lever spring (S)
38	8671306	2.6 φ x 6 DT screw				16	4831614	Head panel
39	4584792	BT bind screw (2)				17	48190082	Actuator spring
40	3392251	REC spring				18	48190092	Auto lever
△41	2702713	Power supply cord [for US, CS]				19	48190002	Auto lever spring
						20	48202142	Button lever spring (B)
						21	4832091	Leaf switch
						22	4832522	Screw
						23	48202192	Head panel
						24	4832451	RWD button lever
						25	48190142	Head base
						26	4832412	Sensing plate assy

SYMBOL No.	PART No.	DESCRIPTION
27	4832452	FF button lever
28	48202212	Head panel spring (S)
29	4832482	Sub. plate
30	48190062	P.R. stopper
31	48190452	PME screw
32	48190172	Azimuth spring
33	4839372	Pinch roller arm assy
34	4850693	Pinch roller spring
35	48316102	Metal guide
36	4839373	RF pulley arm assy
37	48202252	RF pulley arm spring
38	4835913	RF arm collar screw
39	48202272	RF belt
40	4850703	Flywheel assy
41	4833454	Flywheel assy
42	4839377	Take up gear plate assy
43	4839378	Take up roller gear
44	48190202	T.G. plate spring
45	4839379	FF gear
46	4839370	Back tension spring
47	4842431	Supply reel assy
48	4839381	Take up reel assy
49	4832421	Record safety lever
50	4839382	Back tension spring
51	48190392	Motor rubber
52	48195332	Collar screw
53	4833457	Main belt
54	4833452	REC. SP plate
55	4850696	Eject slide lever
56	48190442	Eject slide lever spring
57	48190362	Pack spring
58	48202182	Switch actuator spring
59	48191862	2 φ x 3 tams screw
60	48190632	2 φ x 3 C tapping screw
61	48190682	2 φ x 4 C tapping screw
62	4819607	2 φ x 5 bind tapping screw
63	48196112	2 φ x 6 screw
64	48190602	2 φ x 7 + - cap screw
65	48196002	Azimuth screw
66	48192022	2 φ x 2.5 EH screw (camera)
67	4832471	2 φ x 2.5 screw (camera)
68	4832472	1.7 φ x 4.5 screw (camera)
69	4850698	P washer cut 1.2 φ x 3.7 x 0.4
70	4819078	P washer cut 1.55 φ x 3.8 x 0.5
71	48324322	P washer cut 2.05 φ x 4 x 0.5
72	48195282	Head base
73	4831623	Operation lever
74	4831624	B frame (S)
75	48192322	Button lever shaft
76	48190722	2 φ x 7 screw (for camera)
77	4833463	P kick lever (B)
78	4833464	P kick lever (A)
79	4833465	P.K. collar screw (A)
80	4833460	P. kick lever collar
81	4833467	P kick lever spring
82	4832102	Leaf switch
83	4833468	M.T.A collar
84	4850699	RC lever C
85	4833472	2 φ x 6 C tapping screw
86	46919112	Counter belt
87	48195292	E head spring

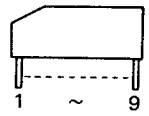
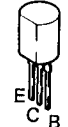
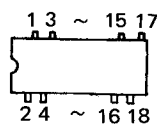
SYMBOL No.	PART No.	DESCRIPTION
88	4850702	Washer 2.4 φ x 7 x 0.1
89	48195442	2 φ x 8 + - cup screw
90	3909461	REC lever (A)
91	4598191	REC lever PK collar screw (A)
92	48195412	E head
93	48190502	R/P head
94	4831657	Motor assy
95	48202152	Sub. chassis
96	48189912	Main base assy
98	4850708	Anti vibration felt mat
99	4833455	PAUSE bracket
100	48191912	Tapping screw 2 φ x 6
101	4835917	Switch bracket
102	4839383	Anti vibration felt mat
103	4835915	Motor bracket

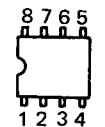
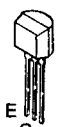
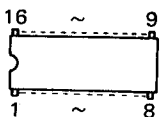
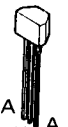
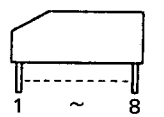
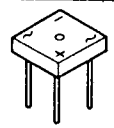
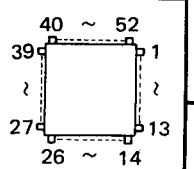
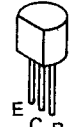
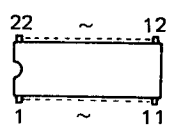
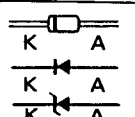
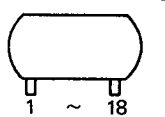
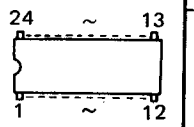
<b>AN278 LB1403</b> 	<b>2SB647C 2SC2235(Y)</b> 
<b>BA3416BL BA3812L</b> 	<b>2SD880(Y)</b> 
<b>BA4558HT</b> 	<b>2SD655(E)</b> 
<b>CXA1101 BA6251 LA3361</b> 	<b>KV1260</b> 
<b>μPC1237HA</b> 	<b>S2VB20 S4VB20</b> 
<b>μPD1713AG-015</b> 	<b>2SA1015(GR) 2SC460B 2SC1740S(S) 2SK104(H)</b> 
<b>LA1265</b> 	<b>11E2 1S2473 1K60R 1S2076A HZ9B1 HZ-15-3 HZ12-B1 HZ6A HZ-6B HZ-3A-3</b> 
<b>STK4112II STK4142II</b> 	
<b>TC9152P</b> 	



**HITACHI SALES EUROPA GmbH**  
Rungedamm 2, 2050 Hamburg 80,  
West Germany  
Tel. 040-734 11-0

**HITACHI SALES (U.K.) Ltd.**  
Hitachi House, Station Road, Hayes, Middlesex UB3  
4DR, England  
Tel. 01-848-8787

**HITACHI SALES SCANDINAVIA AB**  
Rissneleden 8, Box 7138, 172-07 Sundbyberg, Sweden  
Tel. 08-98 52 80

**HITACHI SALES NORWAY A/S**  
P.O. Box 503, Oerebekk, 1620,  
Gressvik, Norway  
Tel. 032-28255

**SUOMEN HITACHI OY**  
Takoankatsu 5, 15800 Lahti 80, Finland  
Tel. (918) 44 241

**HITACHI SALES A/S**  
Kuldysen 13, DK-2630, Taastrup, Denmark  
Tel. 02-999200

**HITACHI SALES A.G.**  
Bahnhofstrasse, 19, 5600 Lenzburg, Switzerland  
Tel. 064-513621

**HITACHI SALES WARENHANDELS GMBH**  
A-1180/Wien, Kreuzgasse 27, Austria  
Tel. 0222-421670

**HITACHI SALES ITALIANA, S.P.A.**  
Via Ludovico di Breme. 9-20156  
MILANO Italy  
Tel. (02) 30231

**HITACHI SALES BELGIUM S.A./N.V.**  
Chaussee de Namur, 56, B-1400 Nivelles, Belgium  
Tel. (3267) 21-71-81, (3267) 21-79-81

**HITACHI SALES IBERICA, S.A.**  
Gran Via Carlos Tercero, 101, 1-1, Barcelona-08028,  
Spain  
Tel. 330-8652

**HITACHI PRODUCTIONS MAROC ELECTRONIQUES  
DOMESTIQUES S.A.**  
Rue du Havre, Casablanca, Morocco  
Tel. 30-73-68, 30-73-57

**HITACHI CANARIAS S.A.**  
Calle San-Francisco No. 19, 38002, Santa Cruz de Tenerife  
Canary Islands  
Tel. 24-64-98

**HITACHI SALES (HELLAS) S.A.**  
110 Syngrou St., Athens, Greece  
Tel. 9219082, 9233469

**HITACHI SALES (MALAYSIA) SDN, BHD.**  
Wisma Hitachi. No. 2. Lorong 13/6A, 46200 Petaling  
Jaya, Malaysia  
Tel. 7573455

**HITACHI (SINGAPORE) PTE., LTD.**  
18 Pasir Panjang Road # 01-03 PSA  
Multi-Storey Complex. Singapore 0511  
Tel. 2738102

**HITACHI SALES (THAILAND) LTD.**  
2240-46, New Petchburi Road, Bangkok, Hueykuang  
Bangkok, Thailand  
Tel. 314-2741

**HITACHI ELECTRIC SERVICE CO., (HONG KONG) LTD.**  
4th Floor Leun Tai Industrial Bldg., 72-76 Kwai Cheong  
Road Kwai Chung N.T., Hong Kong  
Tel. 0-242976, 0-240126

**HITACHI SALES AUSTRALIA PTY LTD.**  
153 Keys Road, Moorabbin, Victoria 3189 Australia  
Tel. 555-8722

**HITACHI SALES CORPORATION OF AMERICA**  
Eastern Regional Office  
1200 Wall Street West, Lyndhurst, New Jersey 07071,  
U.S.A.  
Tel. 201-935-8980

**Mid-Western Regional Office**  
1400 Morse Ave., Elk Grove Village, Illinois. 60007, U.S.A.  
Tel. 312-593-1550

**Southern Regional Office**  
510 Plaza Drive, College Park, Georgia 30349, U.S.A.  
Tel. 404-763-0360

**Headquaters Western Regional Office**  
401 West Artesia Boulevard, Compton, California 90220  
U.S.A.  
Tel. 213-537-8383

**HITACHI SALES CORPORATION OF HAWAII, INC.**  
3219 Koapaka Street. Honolulu, Hawaii 96819, U.S.A.  
Tel. 808-836-3621

**HITACHI (HSC) CANADA INC.**  
3300 Trans-Canada Highway, Pointe Claire, Quebec,  
H9R 1B1, Canada  
Tel. 514-697-9150

**Hitachi Sales Centroamericana, S.A.**  
**HITACHI ELECTRONICA CENTROAMERICANA S.A.**  
San Rafael de Escazu, Apartado 10272, San Jose,  
Costa Rica  
Tel. 28-20-11, 28-00-37

**Hitachi Sales Corporation de Panama, S.A.**  
**INTERNATIONAL HITACHI SALES PANAMA, LTD.**  
**PRODUCTOS HITACHI, S.A.**  
(Apartado 7657) Panama 5 Panama City, Rep. of Panama  
Tel. 61-3100, 61-4305

**HITACHI-FRANCE (RADIO-T.V. ELECTRO-MENAGER) S.A.**  
95-101 Rue Charles Michels,  
93200 SAINT-DENIS,  
France  
Tel. 4821 6015

**HITACHI LTD. TOKYO JAPAN**  
Head Office: THE HITACHI ATAGO BLDG.  
No. 15-12, 2-Chome Nishi-Shinbashi  
Minato-ku, Tokyo 105, Japan  
Tel. Tokyo (03) 502-2111