



HITACHI

SERVICE MANUAL

TY

No. 624 EF

MS-W560

[H, HC, E, E(BS),
W, W(UN), W(AU)]

TN-521ZSW-182

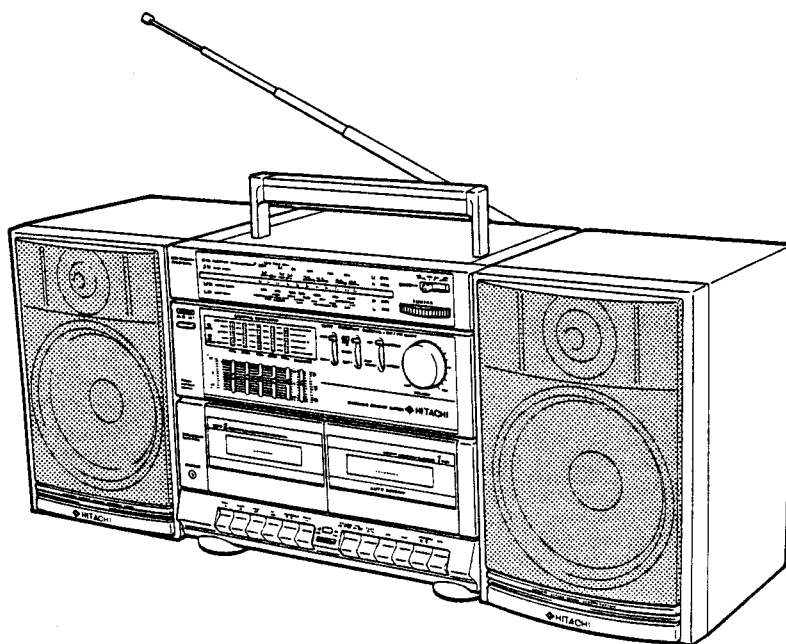

CONTENTS

SPECIFICATIONS	2
MAINTENANCE	3
DISASSEMBLY	4
DIAL CORD STRINGING	8
ADJUSTMENTS	9
INSPECTION OF MECHANISM	13
LUBRICATION	19
BLOCK DIAGRAM	20
CIRCUIT DIAGRAM	21
PRINTED WIRING BOARD	27
WIRING DIAGRAM	33
EXPLODED VIEW	35
REPLACEMENT PARTS LIST	38

TABLE DES MATIERES

CARACTÉRISTIQUE TECHNIQUES	3
ENTRETIEN	3
DÉMONTAGE	4
CHEMINEMENT DU CORDON D'ACCORD	8
RÉGLAGE	14
INSPECTION DU MECANISME	18
LUBRIFICATION	19
DIAGRAMME SYNOPTIQUE	20
PLAN DE CIRCUIT	21
PLAN DE BASE	27
SCHÉMA DE CÂBLAGE	33
VUE EXPLOSEE	35
TABLEAU DES PIÈCES	38

SPECIFICATIONS AND PARTS ARE SUBJECT TO CHANGE FOR IMPROVEMENT.

PORTABLE COMPONENT SYSTEM

July 1989

YOKOHAMA WORKS

SAFETY PRECAUTIONS

The following precautions should be observed when servicing.

1. Since many parts in the unit have special safety-related characteristics, always use genuine Hitachi's replacement parts. Especially critical parts in the power circuit block should not be replaced with other makers. Critical parts are marked with \triangle in the circuit diagram and printed wiring board.
2. Before returning a repaired unit to the customer, the service technician must thoroughly test the unit to ascertain that it is completely safe to operate without danger of electrical shock.

SPECIFICATIONS

• GENERAL

Power supply	AC : 120V, 60 Hz [for H, HC] AC : 220V, 50 Hz [for E] AC : 240V, 50 Hz [for E(BS)] AC : 110-127/200-220/230-250V, 50/60 Hz [for W, W(UN), W(AU)] DC : 15V [IEC R20 ("D"CELL) x 10 or equivalent]
Power consumption	45W
Dimensions	661 (W) x 265 (H) x 234 (D) mm
Weight	8.7 kg (with batteries)

• AMPLIFIER SECTION

Audio output	80W P.M.P (AC operation) [for E, E(BS)] 150W P.M.P (AC operation) [for W, W(UN), W(AU)] 8W/CH (10% T.H.D. AC operation)
Speakers	16cm, 4 Ω (x2) 5cm, 4 Ω (x2)

• TUNER SECTION

Circuit system	FM/SW/MW/LW-4bands superheterodyne [for E, E(BS)] FM/SW2/SW1/MW(AM)-4bands superheterodyne [except E, E(BS)]
Tuning range	FM : 88 to 108 MHz [except E, E(BS)] FM : 87.5 to 108 MHz [for E, E(BS)] SW : 6 to 18 MHz [for E, E(BS)] SW2 : 7 to 22 MHz [except E, E(BS)] SW1 : 2.3 to 7 MHz [except E, E(BS)] MW(AM) : 530 to 1,605 kHz LW : 150 to 285 kHz [for E, E(BS)]

Intermediate

FM : 10.7MHz
SW/MW/LW : 465kHz [for E, E(BS)]
SW2/SW1/MW(AM) : 455kHz [except E, E(BS)]
FM 8 μ V (S/N 26 dB)
AM (MW) 900 μ V/m (S/N 20 dB)
LW 1000 μ V/m (S/N 20 dB) [for E, E(BS)]
SW 40 μ V/m [for E, E(BS)]
SW2 40 μ V/m [except E, E(BS)]
SW1 300 μ V/m [except E, E(BS)]
Antennas
FM SW SW2: Telescopic antenna (aerial)
AM (MW/LW/SW1) : Ferrite core antenna

• TAPE DECK SECTION

Tape	Compact cassette
Tape speed	4.75 cm/s
Recording system and Bias frequency	AC bias, 85 kHz
Track system	4 tracks stereo
Erasing system	AC erase
Frequency Response	Normal 70-12,000 Hz CrO2 70-14,000 Hz
Signal to noise ratio	50 dB
Crosstalk	Between Track 60 dB Between Channel 40 dB
Erase ratio	65 dB
Motor	DC motor
Wow and Flutter	0.25% (WRMS)

* Measured pursuant to the Federal Trade Commission's Trade Regulation Rule on Power Claims for Amplifiers.

Check that exposed parts are acceptably insulated from the supply circuit before returning the instrument repaired to the customer.

• Checking method

Operate switch is set to ON.

Next, measure the resistance value between the both poles of attachment cup (Power supply plug) and the exposed parts (Parts such as Knob, Cover, etc. where the customer is easy to touch.) and check that the resistance value is 500 kohms or more.

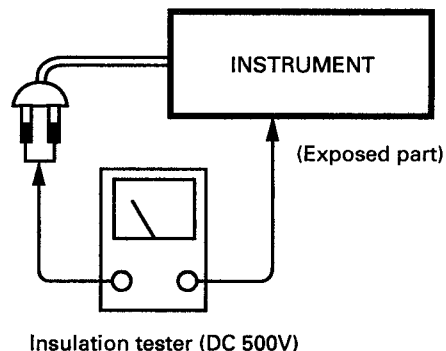

PRÉCAUTIONS DE SÉCURITÉ

Les précautions suivantes doivent être observées chaque fois qu'une réparation doit être faite.

1. Etant donné que de nombreux composants de l'appareil possèdent des caractéristiques relatives à la sécurité, utiliser uniquement des pièces de rechange d'origine Hitachi pour effectuer un remplacement. Ceci se rapporte notamment aux pièces critiques du bloc d'alimentation qui ne doivent en aucun cas être remplacées par celles d'autres fabricants. Les pièces critiques sont accompagnés du symbole  dans le plan de circuit et sur le plan de base.
2. Avant de retourner l'appareil répare au client le technicien doit procéder à un essai complet pour s'assurer qu'il ne présente aucun danger de chocs électriques.

CARACTÉRISTIQUE TECHNIQUES

• GÉNÉRAL

Alimentation	CA : 120V, 60 Hz [pour H, HC] CA : 220V, 50 Hz [pour E] CA : 240V, 50 Hz [pour E(BS)] CA : 110-127/200-220/230-250V, 50/60 Hz [pour W, W(UN), W(AU)] Courant continu : 15V [10 piles IEC R20 (pile "D") ou des piles équivalentes]
Consommation électrique	45W
Dimensions	661 (L) x 265 (H) x 234 (P) mm
Poids	8,7 kg (piles comprises)

• SECTION AMPLIFICATEUR

Sortie audio	80W PMP (fonctionnement sur le secteur) [pour E, E(BS)] 150W PMP (fonctionnement sur le secteur) [pour W, W(UN) W(AU)] 8W/canal (CA à 10% D.H.T.) [pour E, E(BS)]
Haut-parleurs	16cm, 4Ω(x2) 5cm, 4Ω(x2)

• SECTION TUNER

Système de circuit	4 gammes d'ondes FM/OC/PO/GO à superhétérodyne [pour E, E(BS)] 4 gammes d'ondes FM/OC2/OC1/PO(AM) à superhétérodyne [sauf E, E(BS)]
Gammes d'accord	FM : De 88 à 108 MHz [sauf E, E(BS)] FM : De 87,5 à 108 MHz [pour E, E(BS)] OC : De 6 à 18 MHz [pour E, E(BS)] OC2 : De 7 à 22 MHz [sauf E, E(BS)] OC1 : De 2,3 à 7 MHz [sauf E, E(BS)] PO(AM) : De 530 à 1605 kHz GO : De 150 à 285 kHz [pour E, E(BS)]

Fréquence intermédiaire	FM : 10.7 MHz OC/PO/GO : 465kHz [pour E, E(BS)] OC2/OC1/PO(AM) : 455 kHz [sauf E, E(BS)]
Sensibilité	MF 8 μV (S/B 26 dB) AM (PO) 900 μV/m (S/B 20 dB) GO 1000 μV/m (S/B 20 dB) [pour E, E(BS)] OC 40 μV/m [pour E, E(BS)] OC2 40 μV/m [sauf E, E(BS)] OC1 300 μV/m [sauf E, E(BS)]
Antenne	MF OC OC2 : Antenne télescopique (aérien) AM (PO/GO/OC1) : Antenne tore de ferrite

• SECTION MAGNETOCASSETTE

Bande	Compact cassette
Vitesse de défilement	4,75 cm/s
Système d'enregistrement/fréquence de polarisation	Polarisation CA, 85 kHz
Système de piste	4 pistes stéréo
Système d'effacement	Effacement CA
Frequency Response	Normal 70-12000 Hz CrO ₂ 70-14000 Hz
Rapport signal/bruit	50 dB
Transmodulation	Entre les pistes 60 dB Entre les canaux 40 dB
Taux d'effacement	65 dB
Moteur	DC motor
Pleurage et scintillement	0,25% (watts eff.)

* Mesures conformes aux règlements commerciaux de la Federal Trade Commission relatifs à la puissance de sortie des amplificateurs.

MAINTENANCE

■ Clean cabinet and panels when dirty

Clean off dirt on the surfaces with a dry cloth. Never use thinners, benzene or alcohol since these will damage the surface finish.

ENTRETIEN

■ Nettoyage du coffret et des panneaux lorsqu'ils sont sales

Enlever la poussière des surfaces de l'appareil avec un chiffon sec. Ne jamais utiliser de solvants, de benzine ou d'alcool car ils abîmeraient le fini des surfaces.

DISASSEMBLY

1. **Detaching the Speakers from the Unit**
Push the speaker latch towards the center of the unit and pull the speaker box vertically upwards. (Fig. 1)
2. **Removing the Rear Case Assembly**
Remove the five screws ① and the screw ②. Pull off Mic VR knob. Pull the front case assembly forward slightly to separate it from the rear case. Disconnect the connector ④. (Fig. 2)
3. **Removing the Printed Circuit Board M**
Remove the screw ③ and pull off the REC lever. Disconnect the four connectors ⑤ and pull off the Volume knob. Remove the screw ④ holding the heat-dispersion fin. Remove the screw ⑤ holding the dial holder. The printed circuit board M is now free. When removing the printed circuit board M, take care not to damage the connector ⑥ which connects it to the printed circuit board GE. (Fig. 3)
4. **Removing the Printed Circuit Board GE**
Remove the two screws ⑥. The printed circuit board GE can now be removed. (Fig. 3)
5. **Removing the Power Supply Printed Circuit Board**
Remove the two screws ⑦ and four screws ⑧ and disconnect the connector ⑨. Pull the power supply printed circuit board and shield plate assembly forwards out of the case. (Fig. 4)
6. **Removing the Mechanical Deck Assemblies**
Remove the four connectors ⑩ from the printed circuit board M. Open the cassette doors and remove the six screws ⑪. Remove the counter bracket fixing screw ⑫. Remove the deck chassis. (Fig. 5)
*Remove the printed circuit board H/P: the part of the printed circuit board M which is supported by the deck chassis.
7. **Removing the Damper Assembly**
Remove the screw ⑬ from each damper assembly and remove the assembly. (Fig. 6)
8. **Removing the Rod Antenna**
Remove the screw ⑭ and pull out the rod antenna. (Fig. 7)
9. **Removing the Carrying Handle**
Push the lock ribs in the rear case outwards. Each end of the carrying handle can be removed by pulling it towards the rear. (Fig. 7)
10. **Removing the Speakers**
Remove the four screws ⑮ and remove the rear case of the speaker unit. Remove the four screws ⑯ and two screws ⑰ and the speakers can be removed. Follow the same procedure for the left and right speaker units. (Fig. 8)

DÉMONTAGE

1. **Dépose des haut-parleurs de l'appareil**
Enfoncer le verrou de haut-parleur vers le centre de l'appareil, et tirer l'enceinte verticalement vers le haut. (Fig. 1)
2. **Dépose de l'ensemble du boîtier arrière**
Retirer les cinq vis ① et la vis ②. Enlever VR bouton du micro en tirant dessus. Tirer l'ensemble du boîtier avant vers l'avant, afin de le séparer légèrement du boîtier arrière. Débrancher le connecteur ④. (Fig. 2)
3. **Dépose de la plaquette de circuit imprimé M**
Retirer la vis ③ et enlever le levier d'enregistrement (REC) en tirant. Débrancher les quatre connecteurs ⑤ et enlever le bouton du volume en le tirant. Retirer la vis ④ retenant l'sillette de dissipation thermique. Retirer la vis ⑤ retenant la support de cadran. La plaquette de circuit imprimé M est ainsi libérée. Lors du retrait de la plaquette de circuit imprimé M, prendre soin de ne pas endommager le connecteur ⑥ qui la raccorde à la plaquette de circuit imprimé GE. (Fig. 3)
4. **Dépose de la plaquette de circuit imprimé GE**
Retirer les deux vis ⑥. La plaquette de circuit imprimé GE peut alors être déposée. (Fig. 3)

5. Dépose de la plaquette de circuit imprimé d'alimentation

Retirer les deux vis (7) et les quatre vis (8), puis débrancher le connecteur (D). Tirer la plaquette de circuit imprimé d'alimentation et l'ensemble plaque de blindage vers l'avant, pour les sortir du boîtier. (Fig. 4)

6. Dépose de ensembles de platine mécanique

Débrancher les quatre connecteurs (E) de la plaquette de circuit imprimé M. Ouvrir les trappes à cassette et enlever les six vis (9). Retirer la vis (10) d'assemblage de la support contraire. Déposer le châssis de platine. (Fig. 5)

*Déposer la plaquette de circuit imprimé H/P: la partie de la plaquette de circuit imprimé M qui est supportée par le châssis de platine.

7. Dépose de l'ensemble amortisseur

Retirer une vis (11) de chaque ensemble amortisseur, et déposer l'ensemble. (Fig. 6)

8. Dépose du barreau d'antenne

Retirer la vis (12) et enlever le barreau d'antenne en le tirant. (Fig. 7)

9. Dépose de la poignée de transport

Pousser les nervures de verrouillage du boîtier arrière vers l'extérieur.

Chaque extrémité de la poignées de transport peut être retirée en la tirant vers l'arrière. (Fig. 7)

10. Dépose des haut-parleurs

Retirer les quatre vis (13) et déposer le boîtier arrière de l'enceinte.

Retirer les quatre vis (14) et la deux vis (15) le haut-parleur peut alors être déposé.

Procéder de la même manière pour les enceintes de gauche et de droite. (Fig. 8)

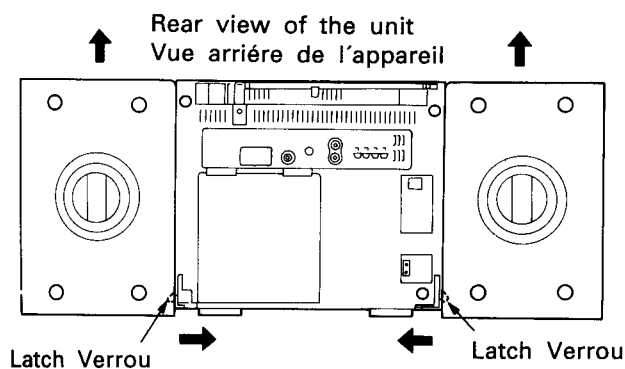

Fig. 1

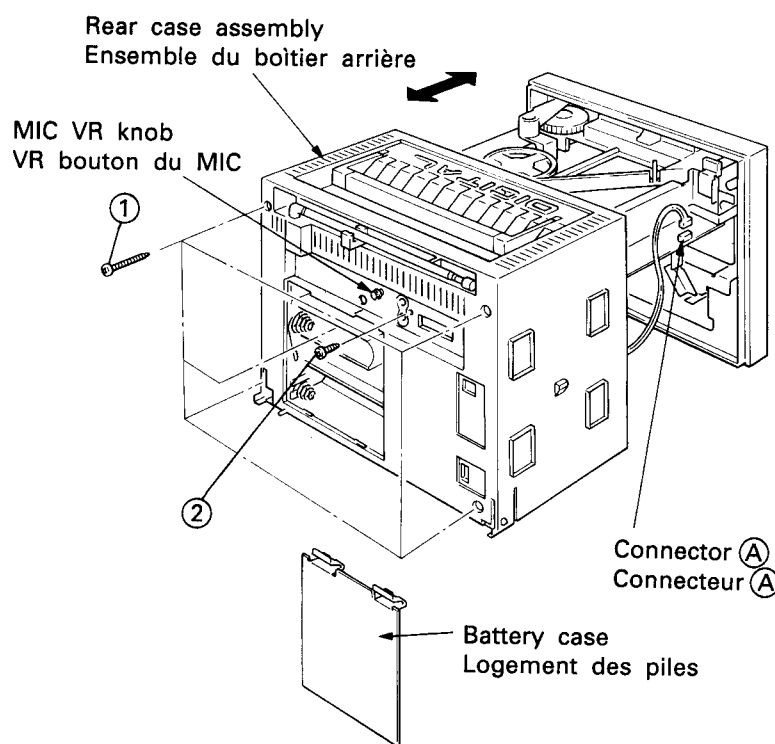
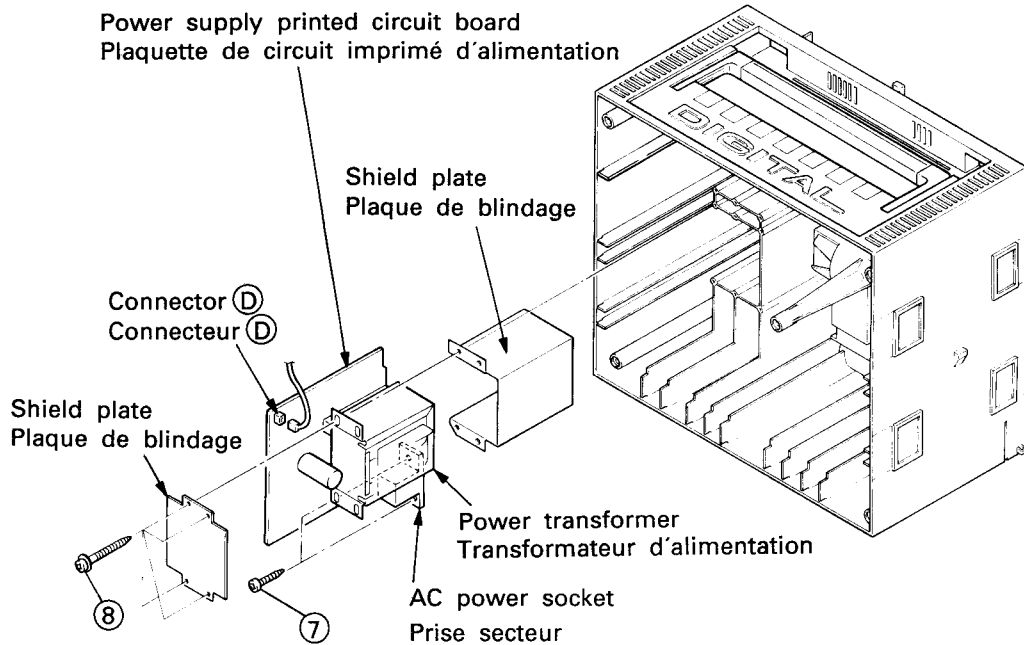
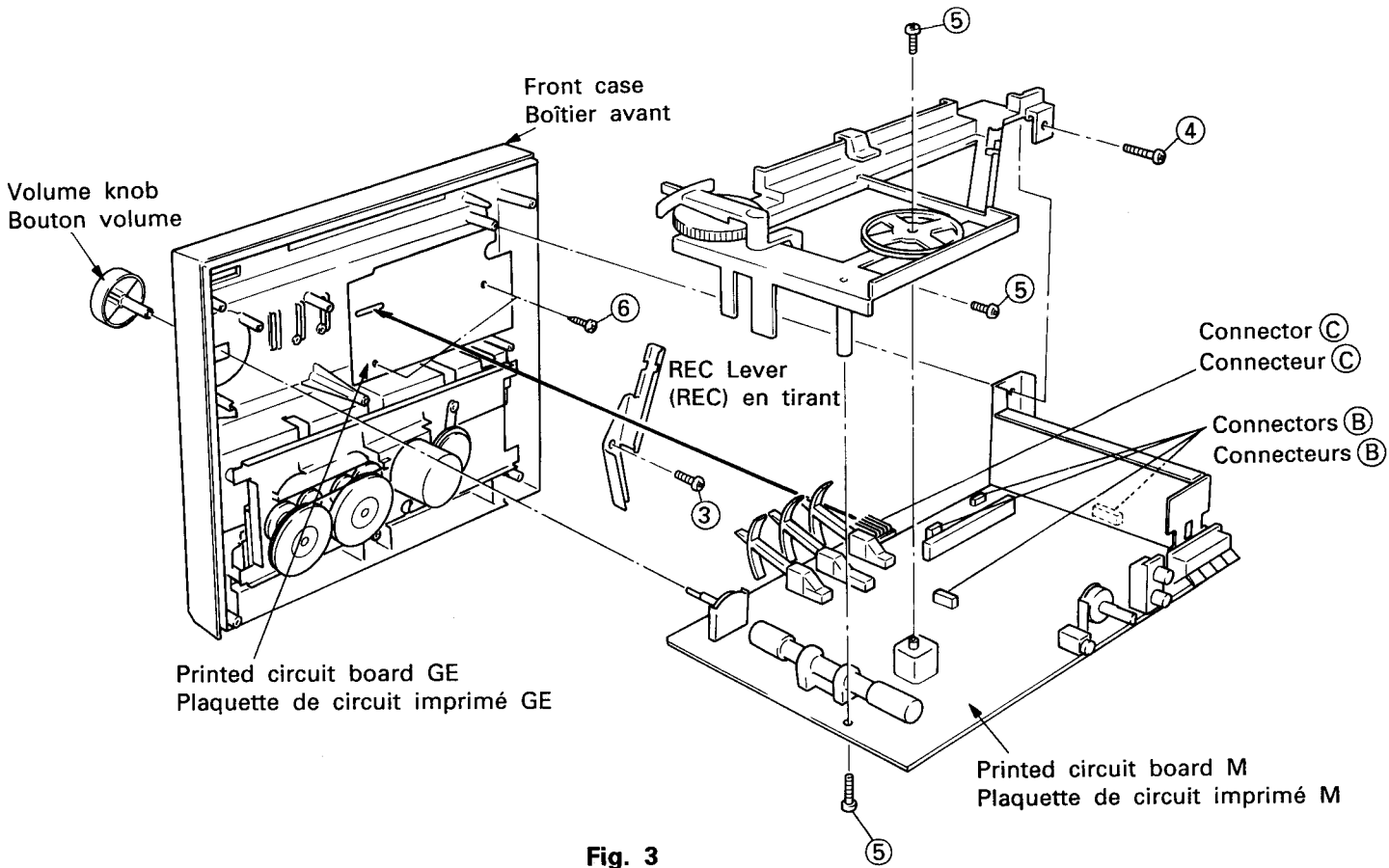

Fig. 2



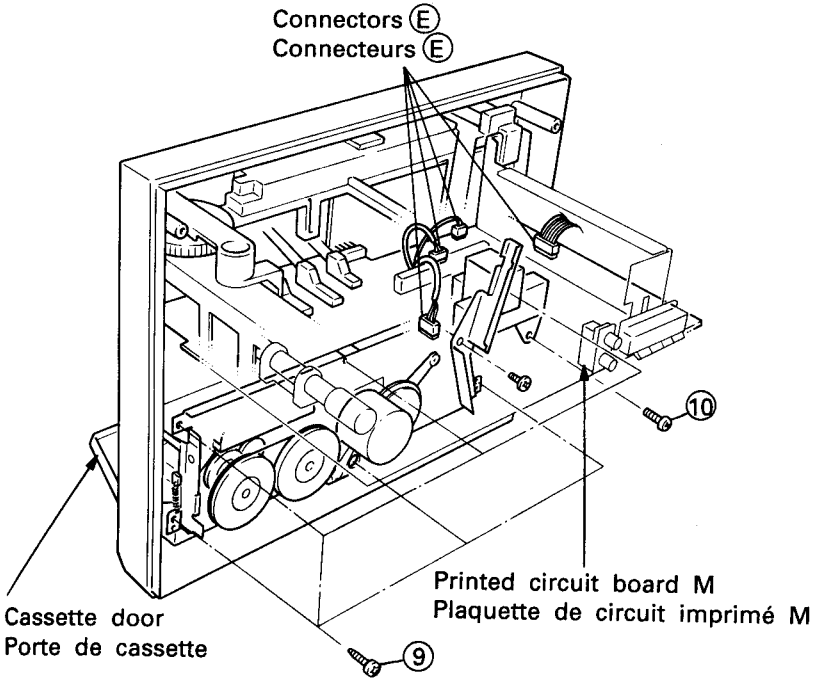

Fig. 5

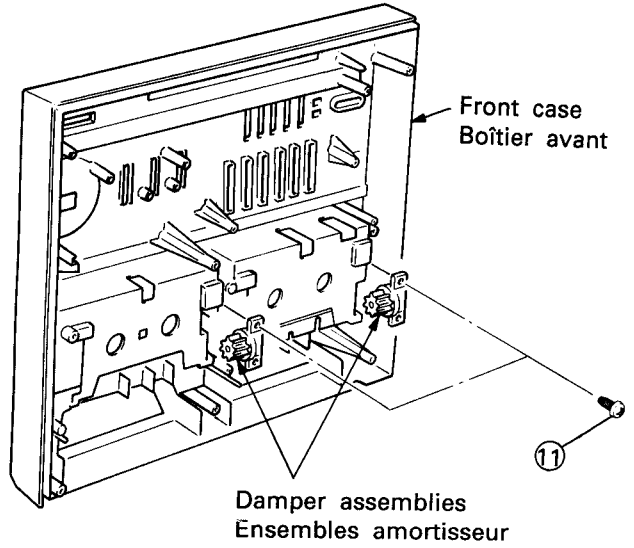

Fig. 6

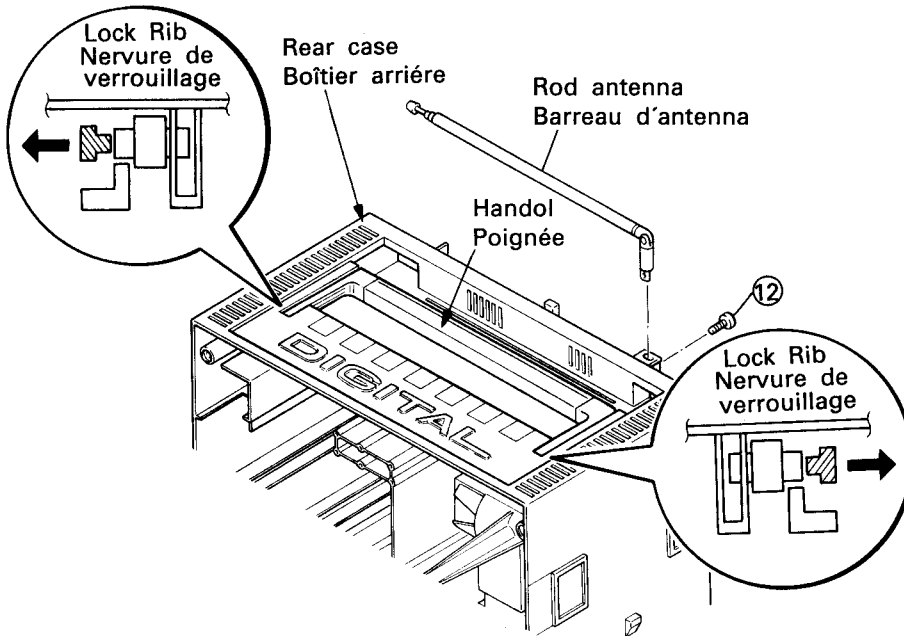

Fig. 7

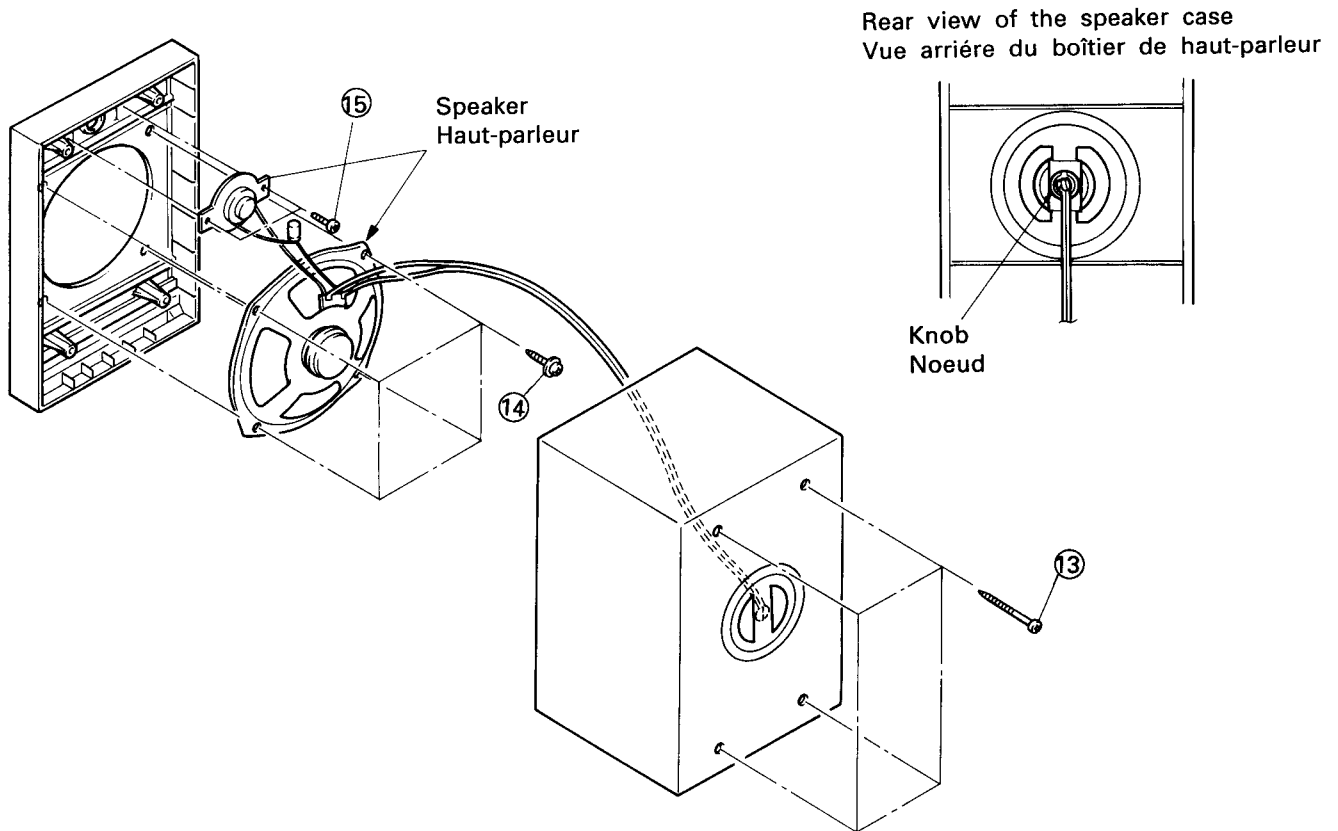

Fig. 8

DIAL CORD STRINGING

Stringing method

1. Turn the pulley fully anti-clockwise until it stop by the stopper on the dial holder.
2. String the dial cord in the direction of the arrows from (Nos. ①-⑧).
3. Set the dial pointer to setting position.

MISE EN PLACE DU CORDON DE CADRAN

Méthode d'enfilage

1. Tourner la poulie à fond dans le sens contraire des aiguilles d'une montre avant que s'arrête à la position d'arrêter sur le support de cadran.
2. Enfiler le cordon de cadran dans le sens de la flèches d'une (No. ① à ⑧).
3. Amener l'aiguille du cadran sur la position de réglage.

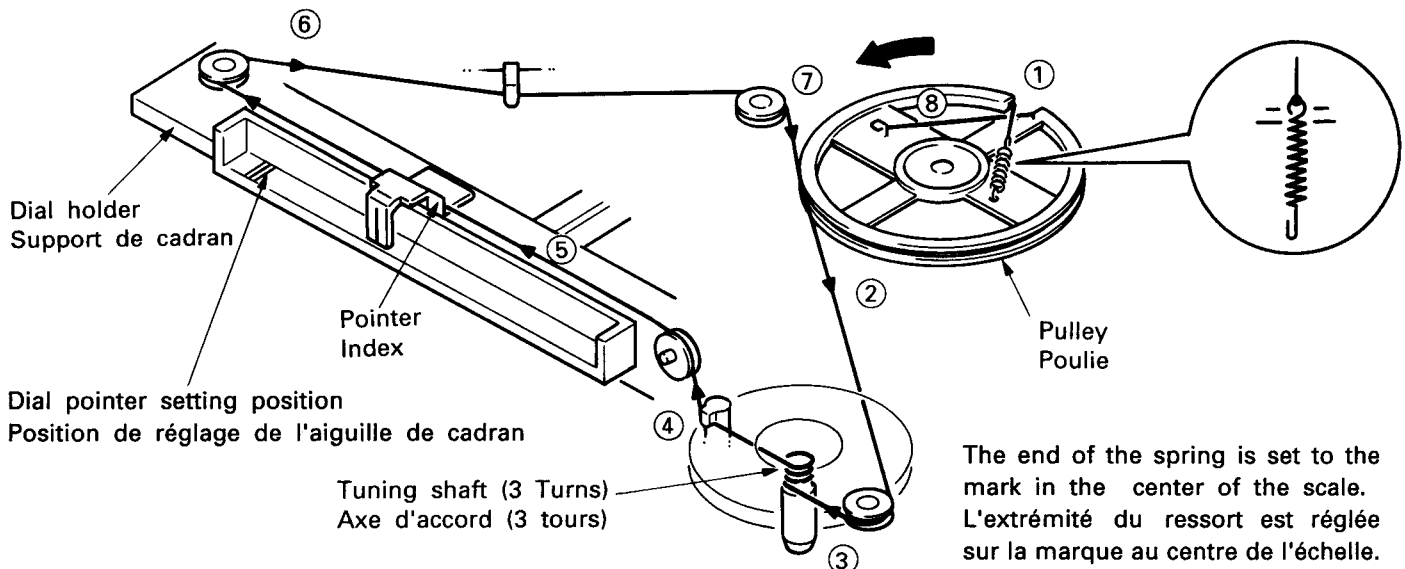

ADJUSTMENT

1. RADIO SECTION

- Adjustment points [except E, E(BS)]

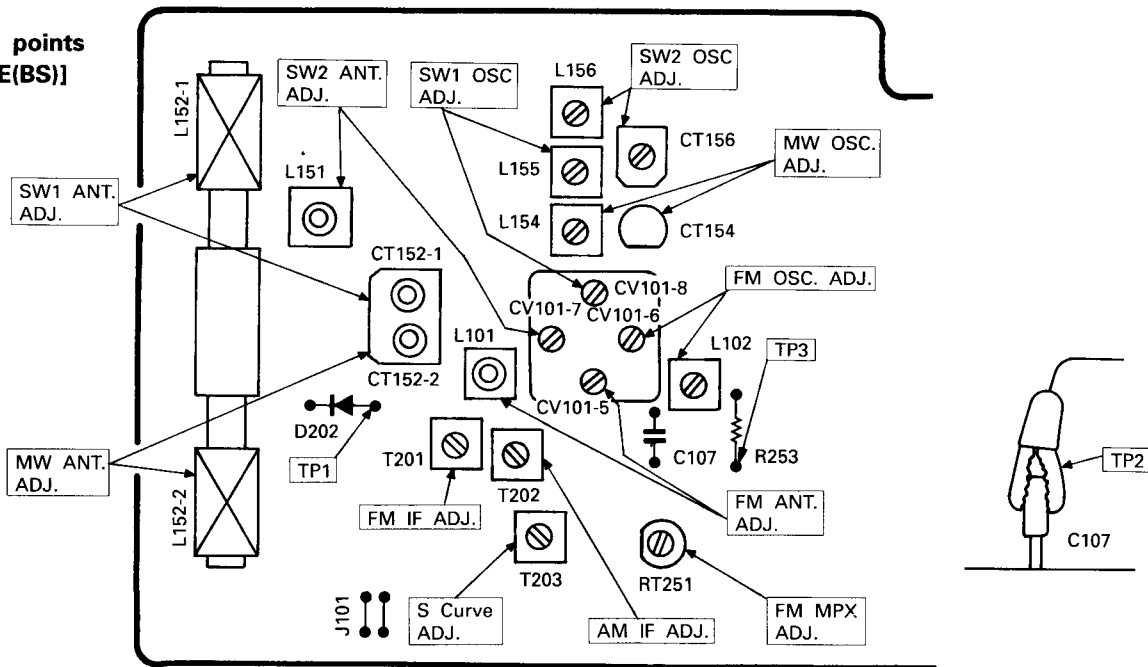

(1)-1 AM Section except E, E(BS) (FM/SW2/SW1/MW 4-bands)

Step	Adjustment Item	Measuring Instrument and Connection			Genescope or Signal Generator Frequency	Dial Pointer Position	Adjust	Reading
		Measuring Instrument	Input Terminal	Output Terminal				
1	(1) (2)	• Genescope (455 kHz)	Ferrite antenna (Note 3)	TP.3	455 kHz	Highest	T202	(Note 1)
2	(1) (2) (3)	• AM signal generator (400 Hz, 30% mod.) • VTVM • Oscilloscope	TP.1 (through SW dummy antenna) (Note 2)	TP.3	6.7 MHz	Lowest	L156	Max.
					23 MHz	Highest	CT156	
					Repeat steps (1) and (2)			
3	(1) (2) (3)	• AM signal generator (400 Hz, 30% mod.) • VTVM • Oscilloscope	TP.1 (through SW dummy antenna) (Note 2)	TP.3	8 MHz	8 MHz	L151	Max.
					20 MHz	20 MHz	CV101-7	
					Repeat steps (1) and (2)			
4	(1) (2) (3)	• AM signal generator (400 Hz, 30% mod.) • VTVM • Oscilloscope	Ferrite antenna (Note 3)	TP.3	2.2 MHz	Lowest	L155	Max.
					7.3 MHz	Highest	CV101-8	
					Repeat steps (1) and (2)			
5	(1) (2) (3)	• AM signal generator (400 Hz, 30% mod.) • VTVM • Oscilloscope	Ferrite antenna (Note 3)	TP.3	2.7 MHz	2.7 MHz	L152-1	Max.
					6.3 MHz	6.3 MHz	CT152-1	
					Repeat steps (1) and (2)			
6	(1) (2) (3)	• AM signal generator (400 Hz, 30% mod.) • VTVM • Oscilloscope	Ferrite antenna (Note 3)	TP.3	515 kHz	Lowest	L154	Max.
					1,650 kHz	Highest	CT154	
					Repeat steps (1) and (2)			
7	(1) (2) (3)	• AM signal generator (400 Hz, 30% mod.) • VTVM • Oscilloscope	Ferrite antenna (Note 3)	TP.3	600 kHz	600 kHz	L152-2	Max.
					1,400 kHz	1,400 kHz	CT152-2	
					Repeat steps (1) and (2)			

• Adjustment points
[for E, E(BS)]

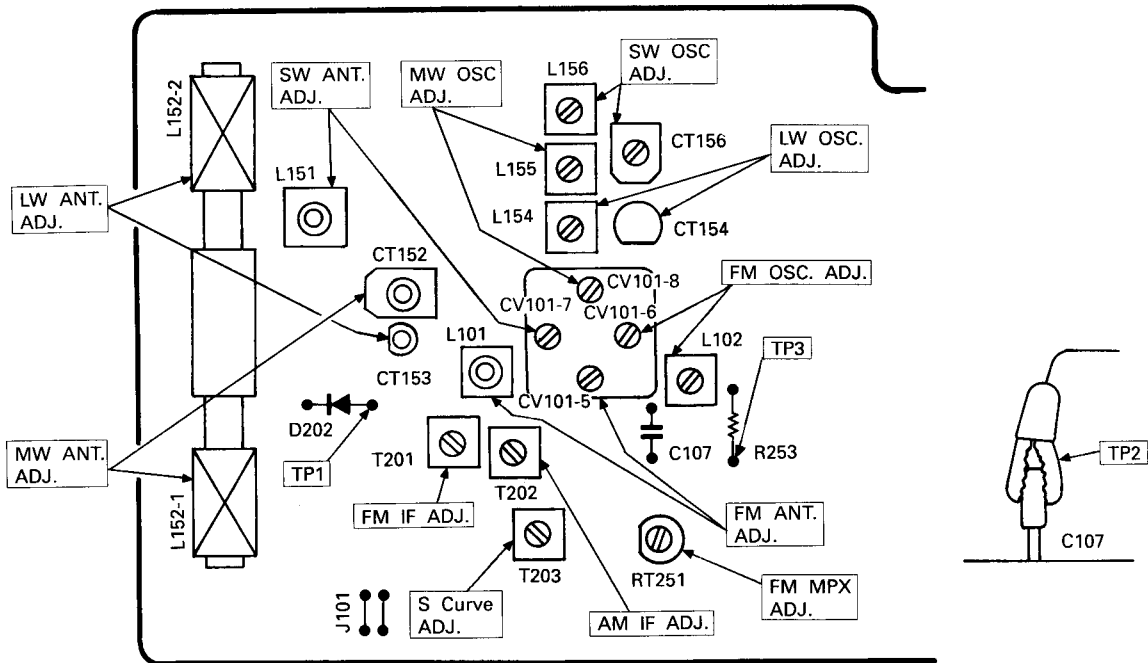

(1)-2 AM Section for E, E(BS) (FM/SW/MW/LW 4-bands)

Step	Adjustment Item	Measuring Instrument and Connection			Genescope or Signal Generator Frequency	Dial Pointer Position	Adjust	Reading
		Measuring Instrument	Input Terminal	Output Terminal				
1	(1) (2) AM IF	• Genescope (465 kHz)	Ferrite antenna (Note 3)	TP.3	465 kHz	Highest	T202	(Note 1)
					Repeat Step (1)			
2	(1) (2) (3) SW OSC. (Covering)	• AM signal generator (400 Hz, 30% mod.) • VTVM • Oscilloscope	TP.1 (through SW dummy antenna) (Note 2)	TP.3	5.8 MHz	Lowest	L156	Max.
					18.5 MHz	Highest	CT156	
					Repeat steps (1) and (2)			
3	(1) (2) (3) SW ANT. (Tracking)	• AM signal generator (400 Hz, 30% mod.) • VTVM • Oscilloscope	TP.1 (through SW dummy antenna) (Note 2)	TP.3	6.5 MHz	6.5 MHz	L151	Max.
					16 MHz	16 MHz	CV101-7	
					Repeat steps (1) and (2)			
4	(1) (2) (3) MW OSC. (Covering)	• AM signal generator (400 Hz, 30% mod.) • VTVM • Oscilloscope	Ferrite antenna (Note 3)	TP.3	515 MHz	Lowest	L155	Max.
					1,650 MHz	Highest	CV101-8	
					Repeat steps (1) and (2)			
5	(1) (2) (3) MW ANT. (Tracking)	• AM signal generator (400 Hz, 30% mod.) • VTVM • Oscilloscope	Ferrite antenna (Note 3)	TP.3	600 MHz	600 MHz	L152-1	Max.
					1,400 MHz	1,400 MHz	CT152	
					Repeat steps (1) and (2)			
6	(1) (2) (3) LW OSC. (Covering)	• AM signal generator (400 Hz, 30% mod.) • VTVM • Oscilloscope (RIF switch: B)	Ferrite antenna (Note 3)	TP.3	145 kHz	Lowest	L154	Max.
					290 kHz	Highest	CT154	
					Repeat steps (1) and (2)			
7	(1) (2) (3) LW ANT. (Tracking)	• AM signal generator (400 Hz, 30% mod.) • VTVM • Oscilloscope (RIF switch: B)	Ferrite antenna (Note 3)	TP.3	160 kHz	160 kHz	L152-2	Max.
					270 kHz	270 kHz	CT153	
					Repeat steps (1) and (2)			

(2)-1 FM Section

Step	Adjustment Item	Measuring Instrument and Connection			Genescope or Signal Generator Frequency	Dial Pointer Position	Adjust	Reading
		Measuring Instrument	Input Terminal	Output Terminal				
1	(1) FM IF	Turn T203 fully counterclockwise			10.7 MHz	Highest	T201	(Note 4)
	(2) S-Curve	• Genescope (10.7 MHz)	TP.2	TP.3			T203	(Note 5)
2	(1) FM OSC. (Covering)	• FM signal generator (400 Hz, 30% dev.) • Oscilloscope • VTVM	TP.1 (through FM dummy antenna) (Note 6)	TP.3	87.3 MHz	Lowest	L102	Max.
					109MHz	Highest	CV101-6	
					Repeat steps (1) and (2)			90MHz
3	(1) FM ANT. (Tracking)				106 MHz	106 MHz	CV101-5	
					Repeat steps (1) and (2)			
					(2)	(3)		
4	(1) FM MPX (Multiplex)	• Frequency counter	Connect a 10 μ F/25V electrolytic capacitor between the No.18 pin of IC201 and GND	No.11 pin of IC201	—	—	RT251	76 kHz \pm 100Hz (Note 7)

Note:

1. Feed in a weak signal from the genescope. Adjust T202 for maximum gain and the waveform indicated in Fig. 9.

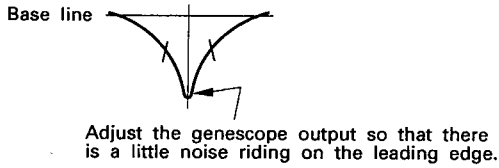

Fig. 9

5. Use the T203 core to form the S-curve shown in Fig. 12. Adjust the symmetry of A and B about point C for linearity.

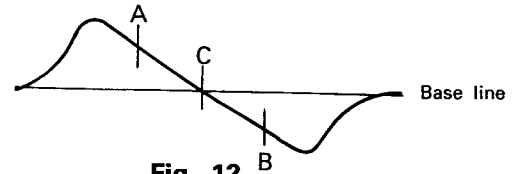

Fig. 12

2. SW dummy antenna shows Fig. 10

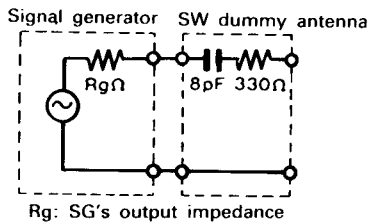

Fig. 10

6. FM dummy antenna shows Fig. 13

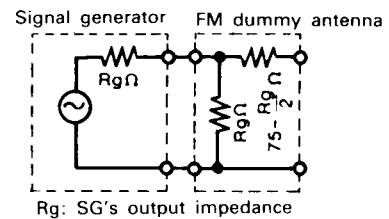

Fig. 13

3. Connect AM signal generator to loop antenna, bring near to ferrite antenna.
4. Feed in a weak signal to TP.2 from the genescope. Adjust T201 for maximum gain and the waveform indicated in Fig. 11. If the center of the waveform cannot be lined up on the marker, adjust the right/left balance.

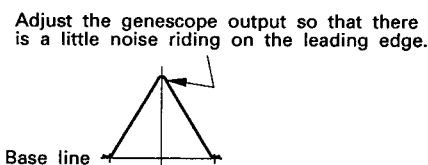

Fig. 11

7. Connect the frequency counter to the No. 11 pin of IC201 and connect a 220 k Ω resistor parallel with the frequency counter.

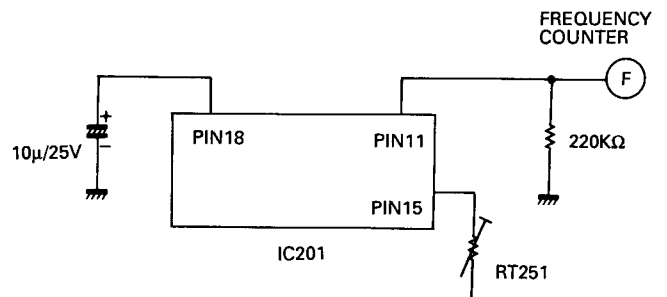

Fig. 14

2. TAPE RECORDER SECTION

Perform the following adjustments in the sequence stated after cleaning the head, pressure roller, and capstan with a head cleaning stick moistened in alcohol. (Note 1)

Step	Adjustment Item	Measuring Instrument and Connection			Check Tape	Mode	Adjust	Reading
		Measuring Instrument	Input Terminal	Output Terminal				
1	Tape speed	• Frequency counter	—	Speaker terminal (4Ω load)	Tape speed adjustment tape (3kHz)	Playback (TAPE2)	RT501	3kHz±20Hz (Note 2)
2	Head azimuth	• VTVM	—	Speaker terminal (4Ω load)	Head azimuth adjustment tape (10kHz)	Playback	Azimuth adjusting screw	Output max. (Note 3)

Note:

- Adjust within 30 sec. after heat-running for more than 20 minutes.
- Should be confirm at TAPE 1 both in the FORWARD and REVERSE directions if the reading is outside the range of adjustment value, make readjustment so that the reading would be 2,975 to 3,030 Hz both in the FORWARD and REVERSE directions.
- When the maximum values of both channels are different, adjust to the maximum value of the L channel. In this case, the difference between the maximum values of both channels should be within 2 dB.

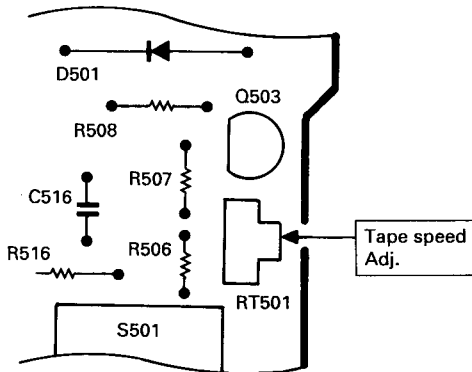

Fig. 15

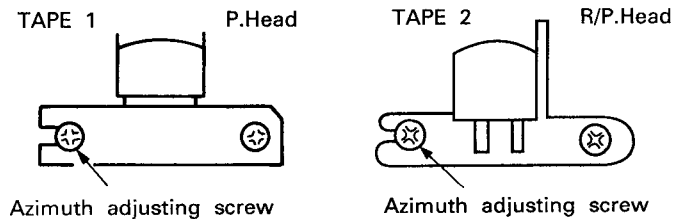

Fig. 16

INSPECTION OF MECHANISM

Item	Checking item		Reference value	Remarks
1	Pressure of pressure roller		300–500 g	Note
2	Take-up torque		30–60 g·m	
3	Fast forward/Rewind torque		50 g·cm or more	
4	Auto-Stop sensor operation force		40–75 g	
5	Brake torque		15 g·cm or more	Measured in stop mode
6	Back tension torque	Take-up	1–6 g·cm	
		Supply	1–4 g·cm	
7	Flywheel thrust gap		0.05–0.5 mm	
8	Button operation force	Play button	1.8 kg or less	
		FF button	1.0 kg or less	
		Rewind button	1.4 kg or less	
		Eject button	1.0 kg or less	
		Record button	2.3 kg or less	
		Pause button	1.0 kg or less	

Note:

Set this unit in the playback mode and press the pressure roller in the direction of the arrow using a fan type tension gauge, and measure the pressure when the pressure roller is released from the capstan.

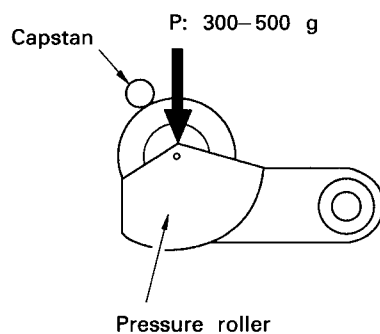
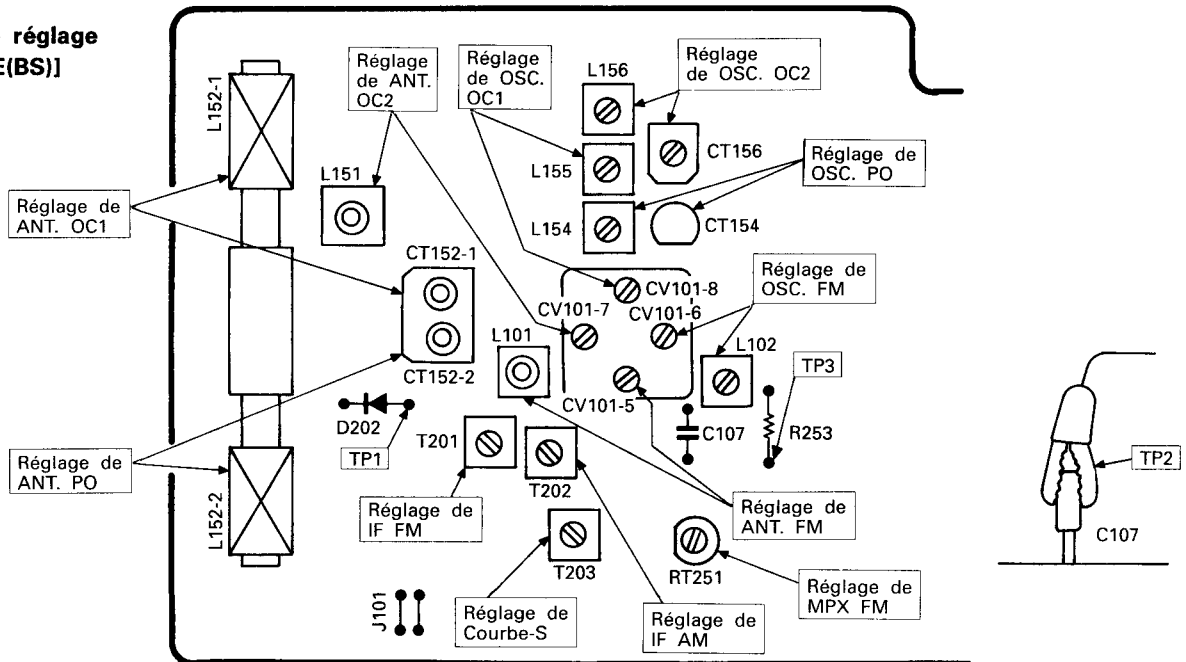

Fig. 17

RÉGLAGE

1. SECTION RADIO

- Points de réglage [sauf E, E(BS)]



(1)-1 Section AM sauf E, E(BS) (FM/OC2/OC1/PO 4 gammes)

Etape	Objet de réglage	Instrument de mesure et branchements			Généscope ou fréquence du générateur de signal	Position de l'aiguille du cadran	Réglage	Lecture
		Instrument de mesure	Borne d'entrée	Borne de sortie				
1	(1) IF AM	• Généscope (455 kHz)	Antenne noyau en ferrite (Remarque 3)	TP.3	455 kHz	La plus haute	T202	(Remarque 1)
2	(1) OSC. OC2 (couverture)	• Générateur de signal AM (400 Hz, mod. 30%) • VTVM • Oscilloscope	TP.1 (par le biais d'une antenne OC fictive) (Remarque 2)	TP.3	6,7 MHz	La plus basse	L156	Max.
					23 MHz	La plus haute	CT156	
					Répéter les étapes (1) et (2)			
3	(1) ANT. OC (poursuite)	• VTVM • Oscilloscope			8 MHz	8 MHz	L151	Max.
					20 MHz	20 MHz	CV101-7	
					Répéter les étapes (1) et (2)			
4	(1) OSC. OC1 (couverture)	• Générateur de signal AM (400 Hz, mod. 30%) • VTVM • Oscilloscope	Antenne noyau en ferrite (Remarque 3)	TP.3	2,2 MHz	La plus basse	L155	Max.
					7,3 MHz	La plus haute	CV101-8	
					Répéter les étapes (1) et (2)			
5	(1) ANT. OC1 (poursuite)	• VTVM • Oscilloscope			2,7 MHz	2,7 MHz	L152-1	Max.
					6,3 MHz	6,3 MHz	CT152-1	
					Répéter les étapes (1) et (2)			
6	(1) OSC. PO (couverture)	• Générateur de signal AM (400 Hz, mod. 30%) • VTVM • Oscilloscope	Antenne noyau en ferrite (Remarque 3)	TP.3	515 kHz	La plus basse	L154	Max.
					1650 kHz	La plus haute	CT154	
					Répéter les étapes (1) et (2)			
7	(1) ANT. PO (poursuite)	• VTVM • Oscilloscope			600 kHz	600 kHz	L152-2	Max.
					1400 kHz	1400 kHz	CT152-2	
					Répéter les étapes (1) et (2)			

(2)-1 Section FM

Etape	Objet du réglage		Instrument de mesure et branchement			Généscope ou fréquence du générateur de signal	Position de l'aiguille du cadran	Réglage	Lecture
			Instrument de mesure	Borne d'entrée	Borne de sortie				
1	(1)	IF FM	Tourner T201 à fond dans le sens des aiguilles d'une montre			10,7 MHz	La plus haute	T201	(Remarque 4)
	(2)	Coubre-S	• Généscope (10,7 MHz)	TP.2	TP.3			T203	(Remarque 5)
2	(1)	OSC. FM (couverture)	• Générateur de signal FM (400 Hz, dév. 30%) • Oscilloscope • VTVM	TP.1 (par le biais d'une antenna FM fictive) (Remarque 6)	TP.3	87.3 MHz	La plus basse	L102	Max.
	(2)					109 MHz	La plus haute	CV101-6	
	(3)					Répéter les étapes (1) et (2)			
3	(1)	ANT. FM (poursuite)				90 MHz	90 MHz	L101	Max.
	(2)					106 MHz	106 MHz	CV101-5	
	(3)					Répéter les étapes (1) et (2)			
4	(1)	MPX FM (Multiplex)	• Freqüencemètre	Brancher un condensateur électrolytique de 10µF/25V entre la broche n°18 du IC201 et la masse (GND).	Broche n°11 du IC201	—	—	RT201	76 kHz ±50Hz (Remarque 5)

Remarque:

- Appliquer un signal faible du généscope. Régler T202 afin d'obtenir un gain maximum et la forme d'onde de la Fig. 9.

Ligne de base

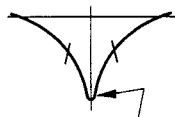

Régler la sortie du généscope de façon à ce qu'il y ait un peu de bruit au niveau du front d'onde.

Fig. 9

- Antenne OC fictive

Générateur de signal Antenne OC fictive

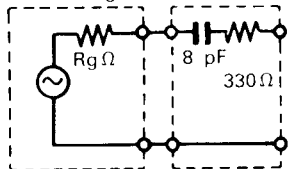

Rg : impédance de sortie du générateur de signal

Fig. 10

- Relier le générateur de signal AM à l'antenne-cadre. La rapprocher de l'antenne noyau en ferrite.

- Appliquer un signal faible du généscope sur TP.2. Régler T201 afin d'obtenir un gain maximum et la forme d'onde de la Fig. 11. Si le centre de la forme d'onde ne peut pas être aligné sur le marqueur, régler la balance droite/gauche.

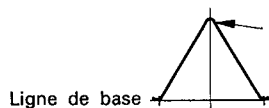

Ligne de base

Régler la sortie du généscope de façon à ce qu'il y ait un peu de bruit au niveau du front d'onde

Fig. 11

- Utiliser le noyau de T203 pour former la coubre-S indiquée sur la Fig. 12. Régler la symétrie de A et B au niveau du point C pour la linéarité.

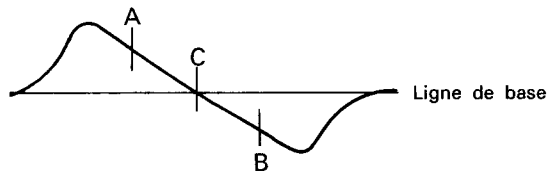
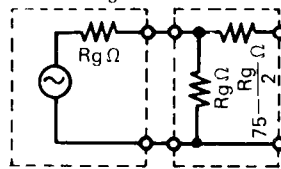

Fig. 12

- Antenne FM fictive

Générateur de signal Antenne FM fictive



Rg : impédance de sortie du générateur de signal

Fig. 13

- Relier le fréquencemètre sur la broche n°11 du IC201 et brancher une résistance de 220 kΩ en parallèle avec le fréquencemètre.

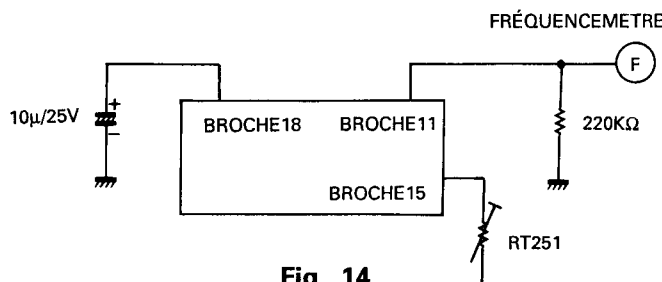

Fig. 14

2. SECTION LECTEUR-ENREGISTREUR DE CASSETTE

Effectuer les réglages suivants dans l'ordre indiqué après avoir nettoyé la tête, le galet-presseur et le cabestan avec un coton-tige imbibé d'alcool. (Remarque 1)

Etape	Objet de réglage	Instrument de mesure et branchements			Band de vérification	Mode	Réglage	Lecture
		Instrument de mesure	Borne d'entrée	Borne de sortie				
1	Vitesse de défilement	• Fréquence-mètre	—	Borne de hautparleur (charge de 4Ω)	Bande de réglage de vitesse de défilement (3 kHz)	Reproduction	RT501	3kHz ± 20Hz (Remarque 2)
2	Azimuth de tête	• VTVM	—	Borne de hautparleur (charge de 4Ω)	Bande de réglage d'azimuth de tête (10 kHz)	Reproduction	Vis de réglage d'azimuth	Sortie max. (Remarque 3)

Remarque:

- Régler dans une plage de 30 sec. après une mise sous tension de 20 minutes au moins.
- Vérifier la Platine 1 à la fois dans les directions FORWARD (avant) et REVERSE (arrière). Si la lecture est en dehors de la plage des valeurs de réglage, faire le réglage de façon à ce que la lecture soit entre 2975 et 3030 Hz dans les directions FORWARD (avant) et REVERSE (arrière).
- Si les valeurs maximales des deux canaux diffèrent, régler sur la valeur maximale du canal de gauche (L). Dans ce cas, la différence entre les valeurs maximales des deux canaux doit être comprise dans une plage de 3 dB.

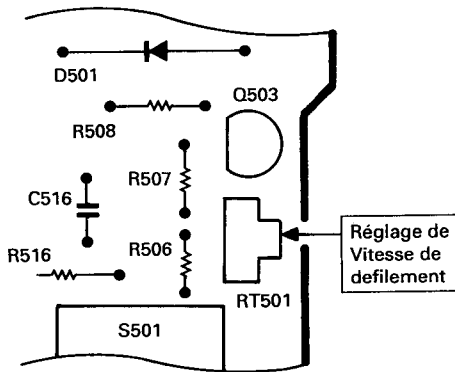
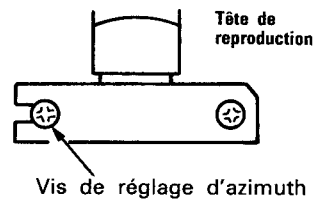

Fig. 15

Platine 1



Platine 2

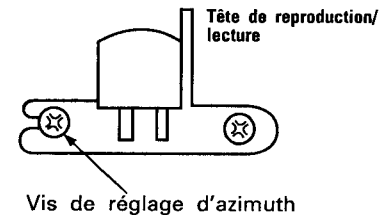

Fig. 16

INSPECTION DU MECANISME

Point	Poste de vérification	Valeur de référence	Remarques
1	Pression du galet-presseur	300–500 g	Remarque
2	Couple d'enroulage	30–60 g·m	
3	Couple d'avancé rapide/rembobinage rapide	50 g·cm or more	
4	Effort à l'utilisation du détecteur pour arrêt automatique	40–75 g	
5	Couple de freinage	15 g·cm or more	Mesuré en mode d'arrêt
6	Couple de tention de recul	Enroulage	1–6 g·cm
		Alimentation	1–4 g·cm
7	Intervalle de poussé du volant	0,05–0.5 mm	
8	Button operation force	Touche de reproduction	1,8 kg ou moins
		Touche d'avancée rapide	1,0 kg ou moins
		Touche de rembobinage	1,4 kg ou moins
		Touche d'éjection	1,0 kg ou moins
		Touche d'enregistrement	2,3 kg ou moins
		Touche de pause	1,0 kg ou moins

Remarque:

Placez cet appareil en mode de reproduction, appuyez sur le galet-presseur dans le sens de la flèche à l'aide d'un calibre de tension type éventail, et mesurez la pression lorsque le galet-presseur est libéré du cabestan.

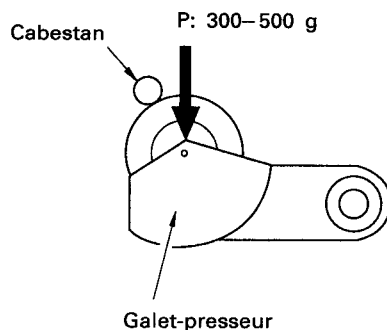

Fig. 17

LUBRICATION

Apply one or two drops of pan motor oil or sonic slider oil to rotating parts. Coat sliding parts with Molycoat (EL-10M).

Lubricate once a year or every 1,000 hours of operation. Do not let oil contact belts or idlers.

Rotating parts	Metal to metal	Pan motor oil (10W-40)
	Plastics to metal	Sonic slider oil (#1600)
Sliding parts	(Note) Plastics to plastics Plastics to metal	Molycoat (EL-10M)
Spring vibration prevention		Floyl (GB-TS-1)

NOTE:

When front frame and slide knob are replaced, coat both contacting parts lightly with white grease.

LUBRIFICATION

Appliquer une ou deux gouttes d'huile moteur ou d'huile Sonic pour curseur, sur les membres rotatifs. De la graisse Molycoat (EL-10M) est appliquée sur les membres coulissants.

Lubrifier une fois par an ou toutes les 1,000 heures de fonctionnement.

Veiller à ne pas appliquer d'huile sur les courroies ou les galets.

Membres rotatifs	Entre les parties Métalliques	Huile moteur (10W-40)
	Entre le moulage et les parties métalliques	Huile Sonic pour curseur (#1600)
Membres Coulissants	(Remarque) Entre moulures Entre moulures et pièces métalliques	Molycoat (EL-10M)
Prévention de vibration de ressort		Floyl (GB-TS-1)

Remarque:

Lorsque le châssis avant et le boulon curseur doivent être remplacés, appliquer une couche légère de graisse blanche sur les parties de contact.

BLOCK DIAGRAM • DIAGRAMME SYNOPTIQUE

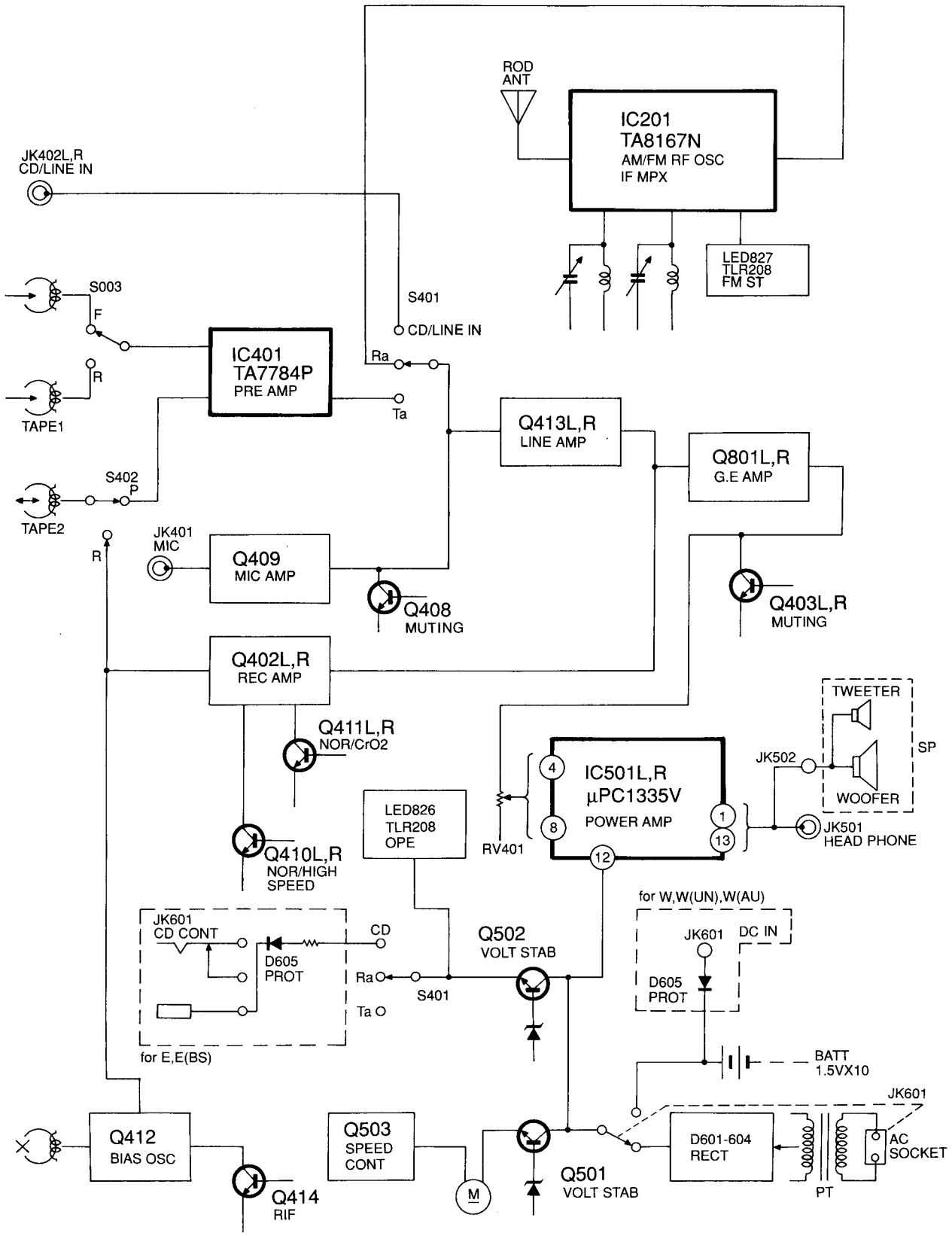

CIRCUIT DIAGRAM · DIAGRAMME DES CIRCUITS

TUNER SECTION

CAUTION
Use the electrolytic capacitors with
explosion-proof valve when the
diameter of them is more than
10mmø.

M P.W.B.(2/2)

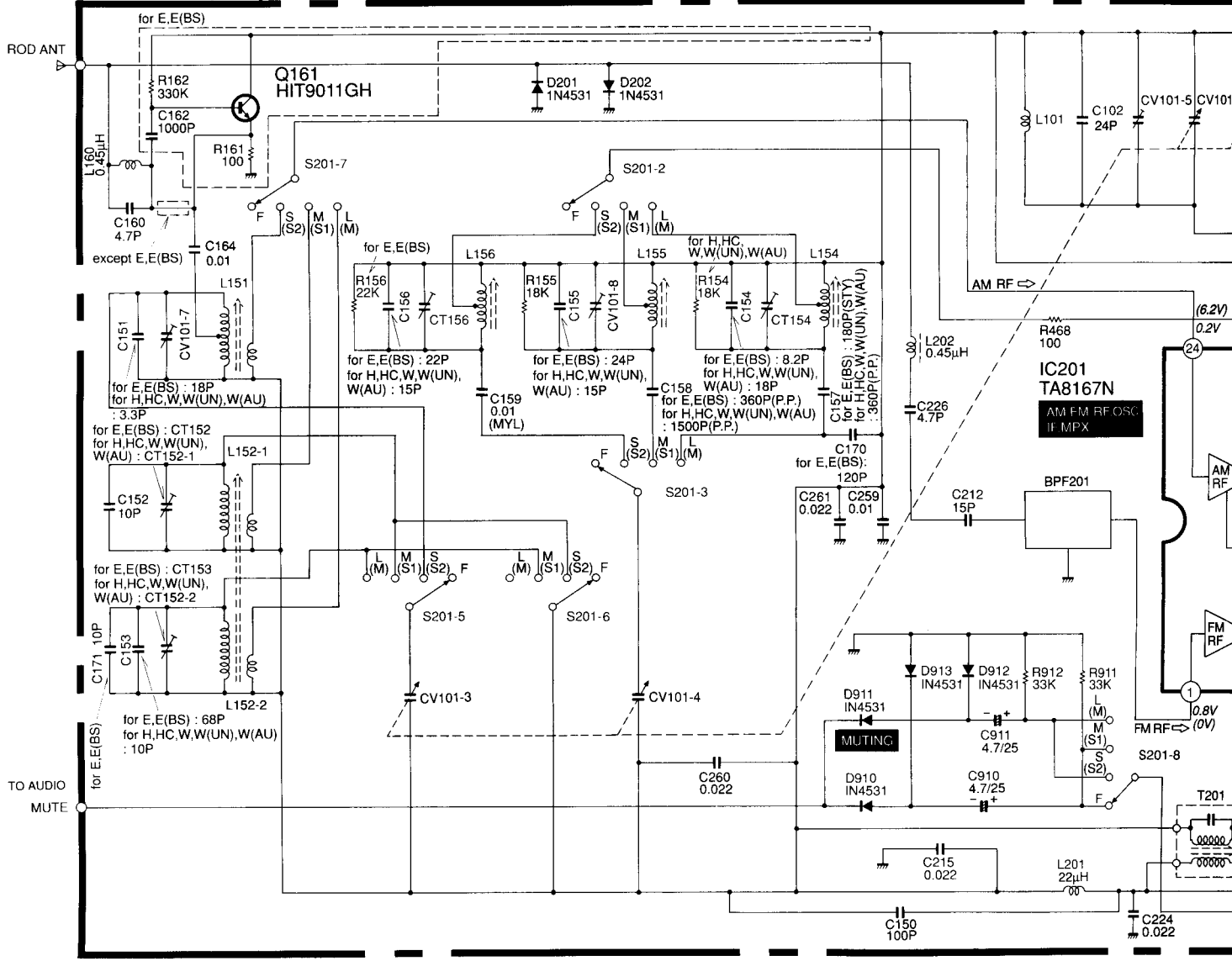

() VOLTAGE : AM

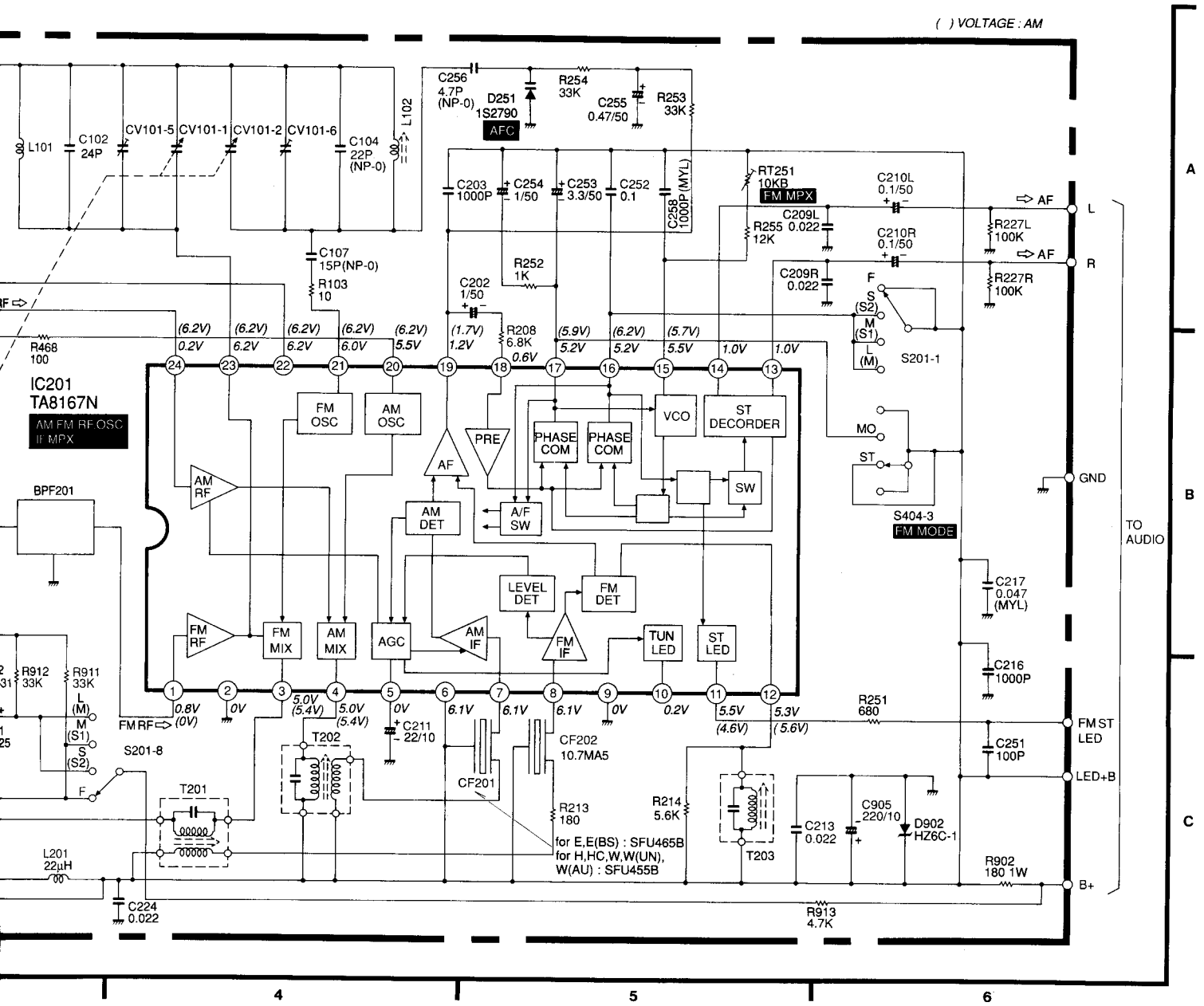

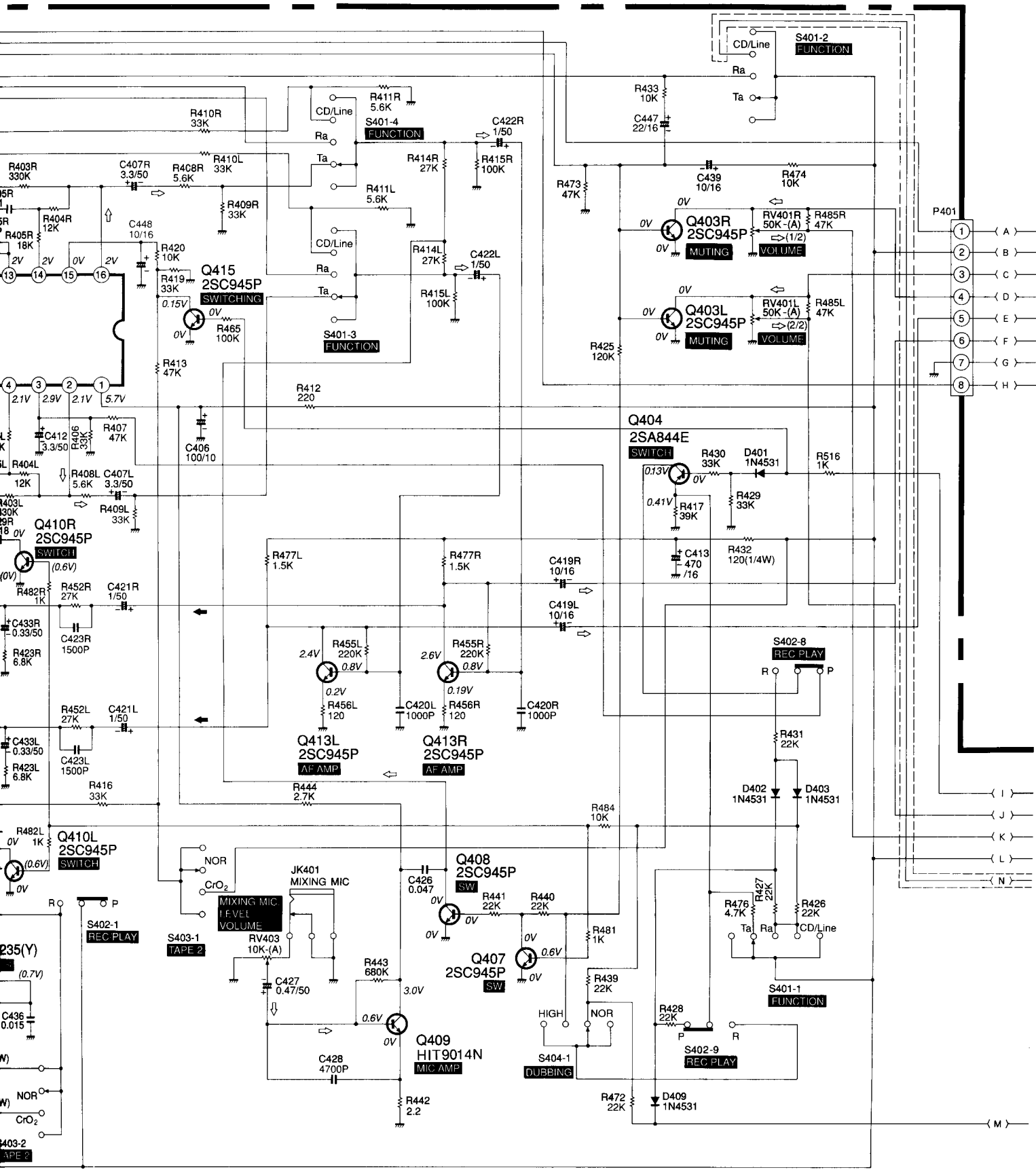

3

4

5

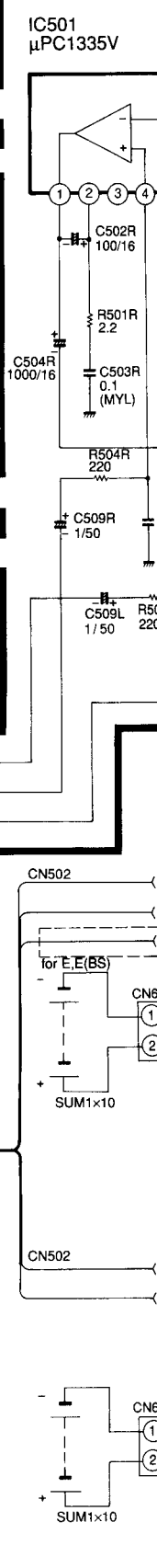
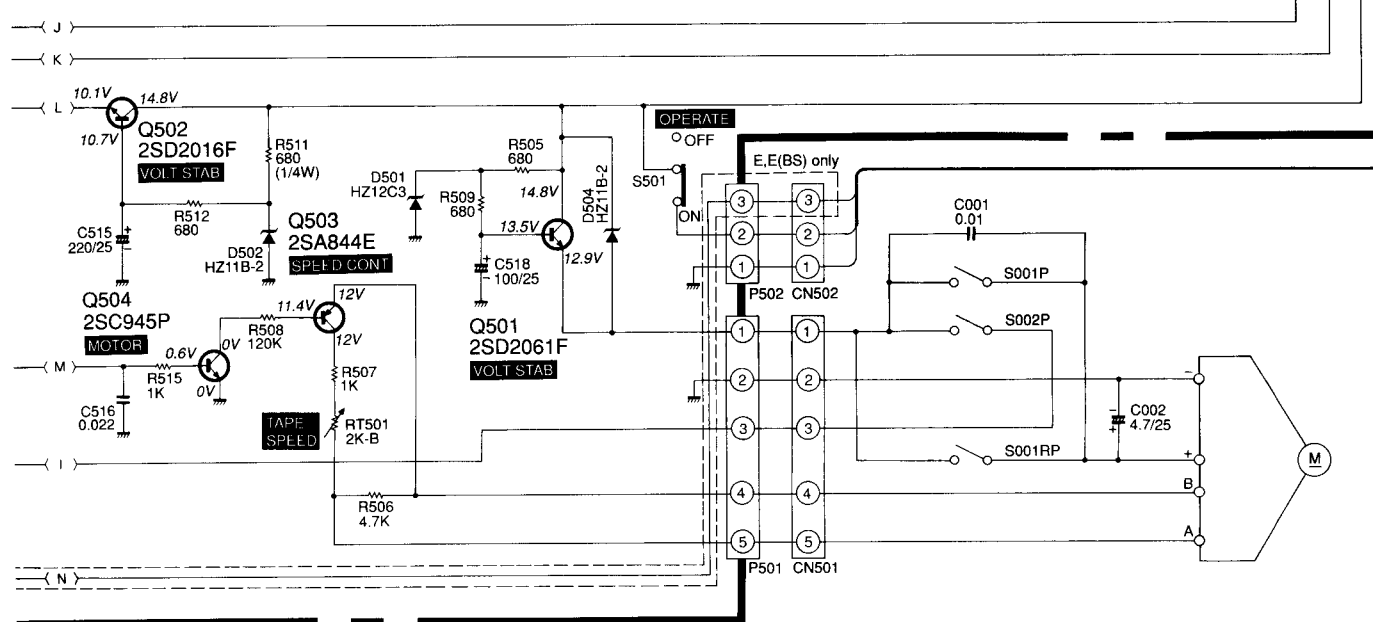
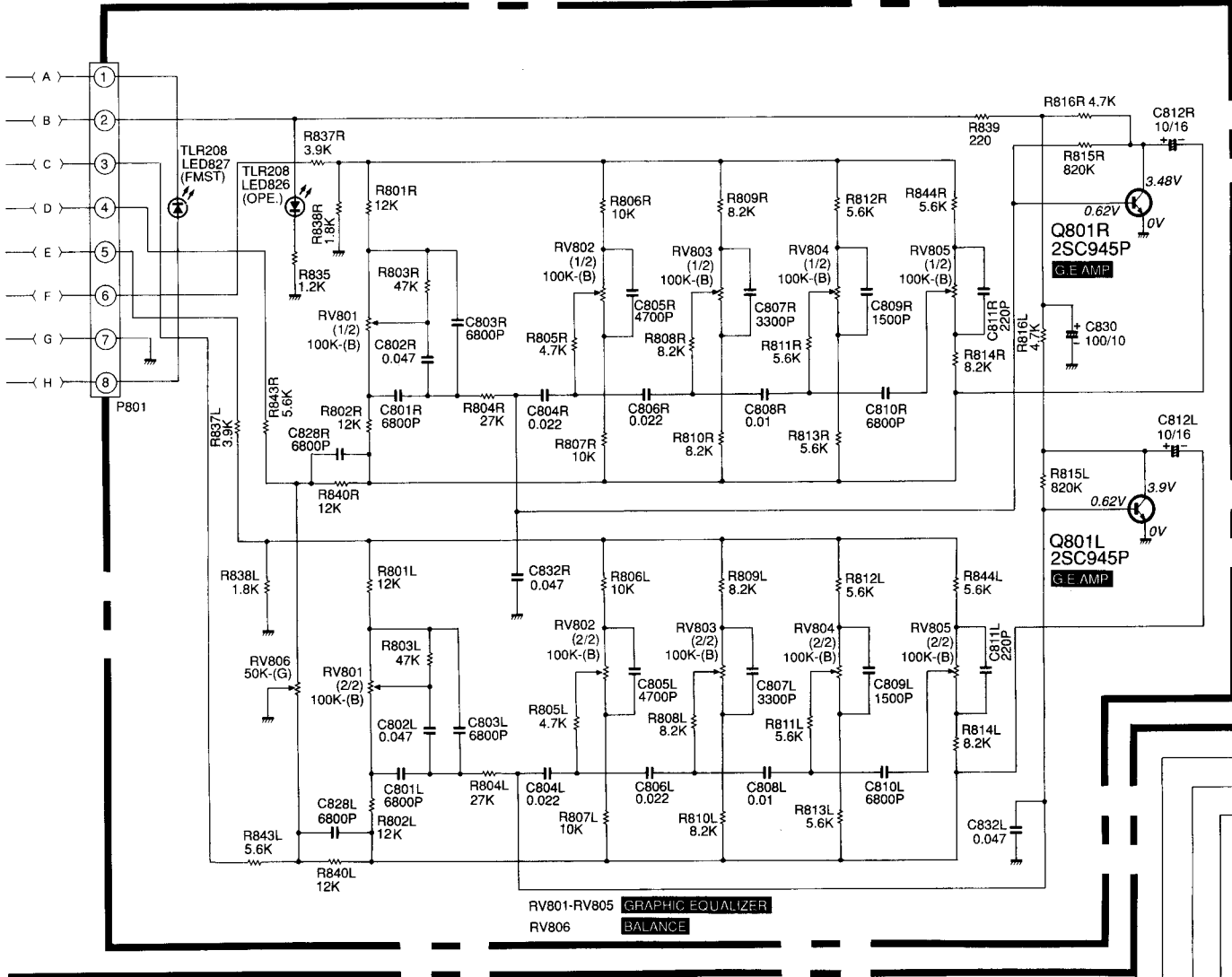

M P.W.B.(1/2)

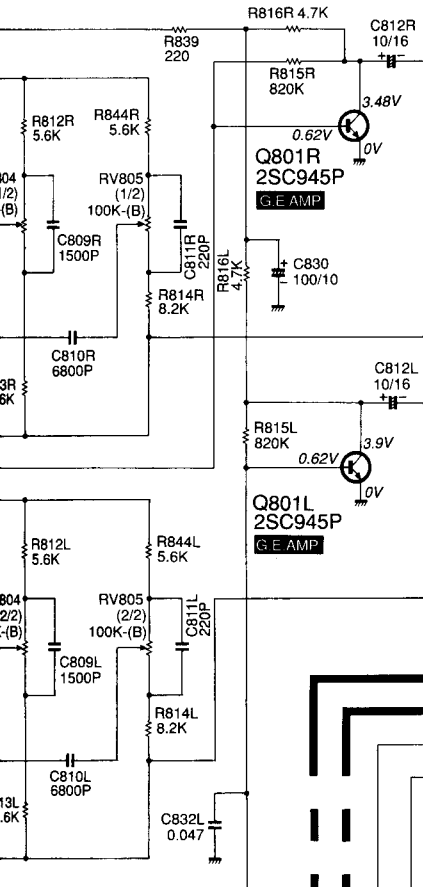

IC501
μPC1335V

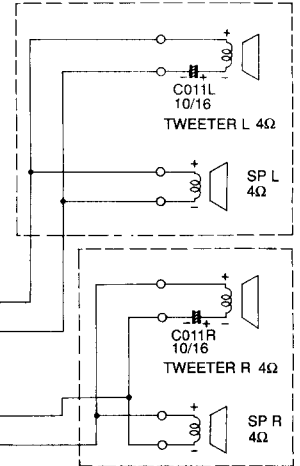
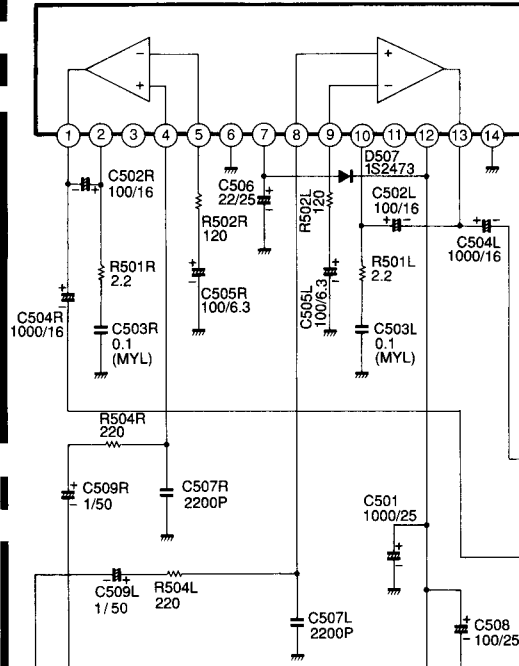

HP P.W.B.

for E,E(BS),H,HC P P.W.B.

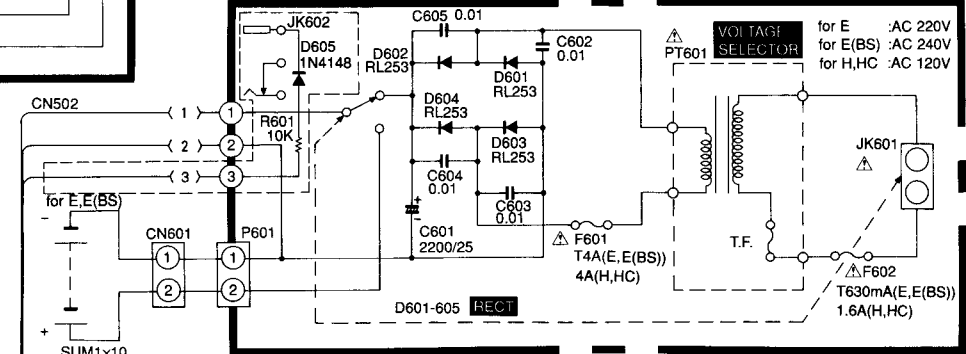

for W,W(UN),W(AU) P P.W.B.

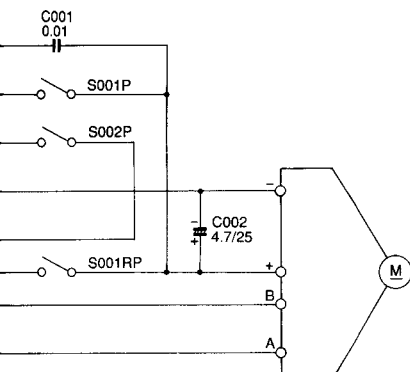
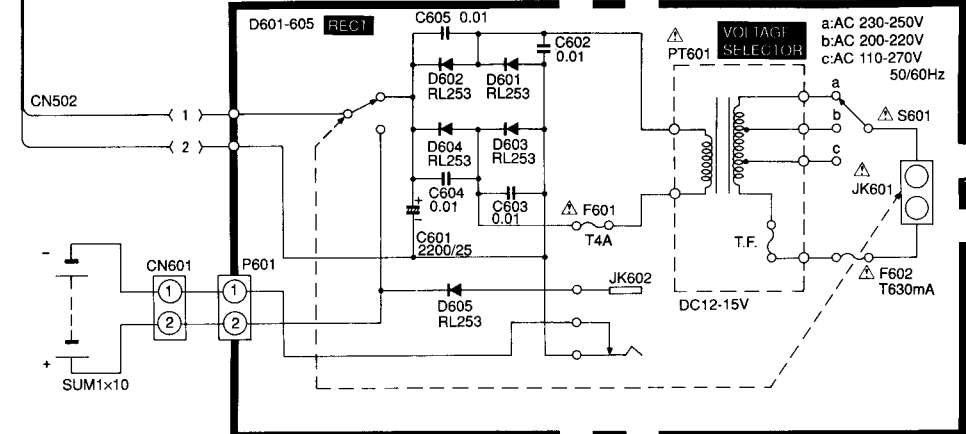

8

9

10

WIRING BOARD • PLAN DE BASE

M.P.W.B.

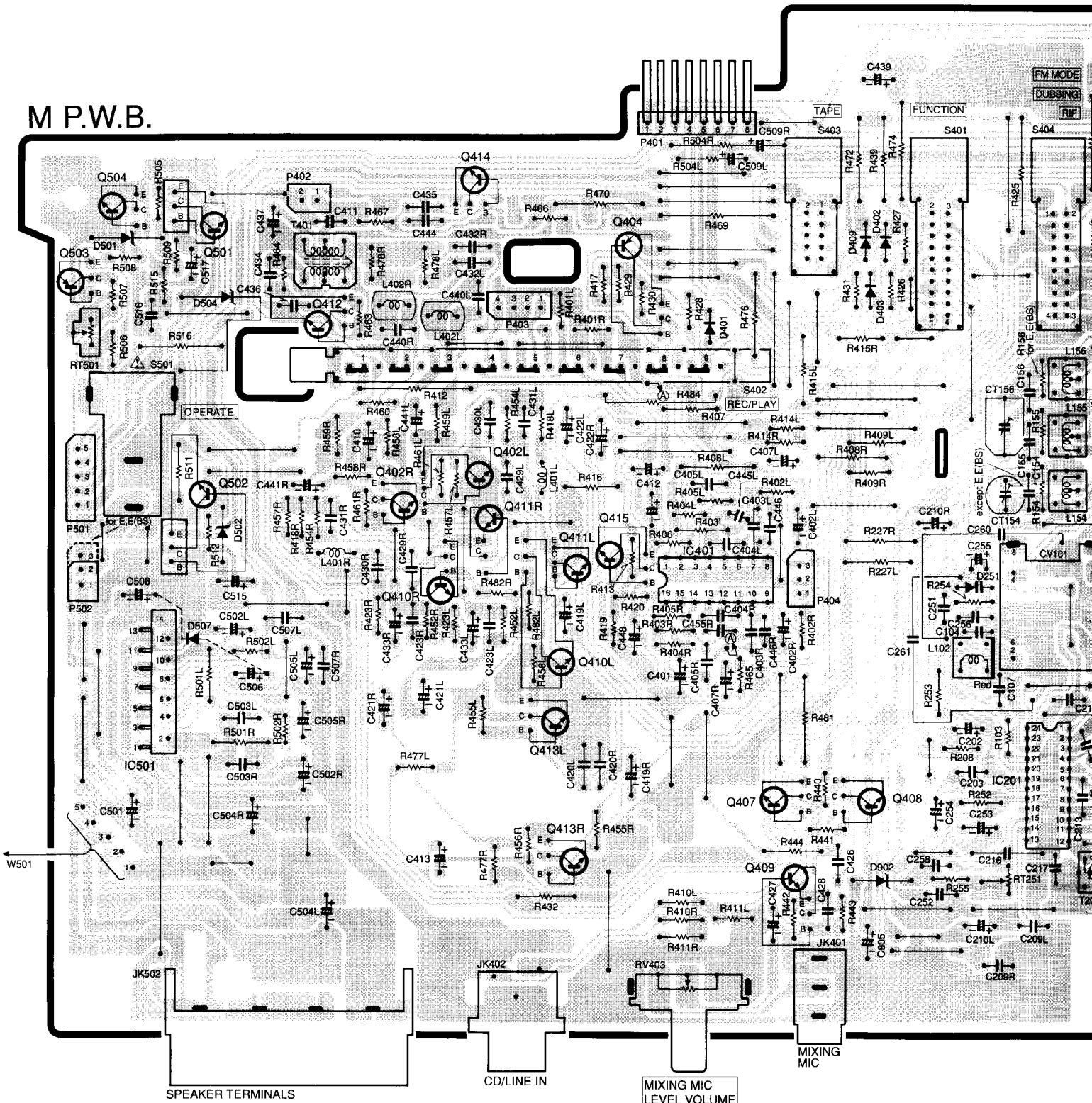

- | | | | | | | | | | | | | |
|-------|------|------|------|-------|-------|-------|-------|------|-------|------|------|-------|
| Q503 | Q504 | Q501 | Q412 | Q402R | Q414 | Q410L | Q411L | Q404 | IC401 | Q407 | Q408 | IC201 |
| IC501 | Q502 | | | Q410R | Q402L | Q413L | Q413R | Q415 | | Q409 | | |
| | | | | Q411R | | | | | | | | |

1

2

3

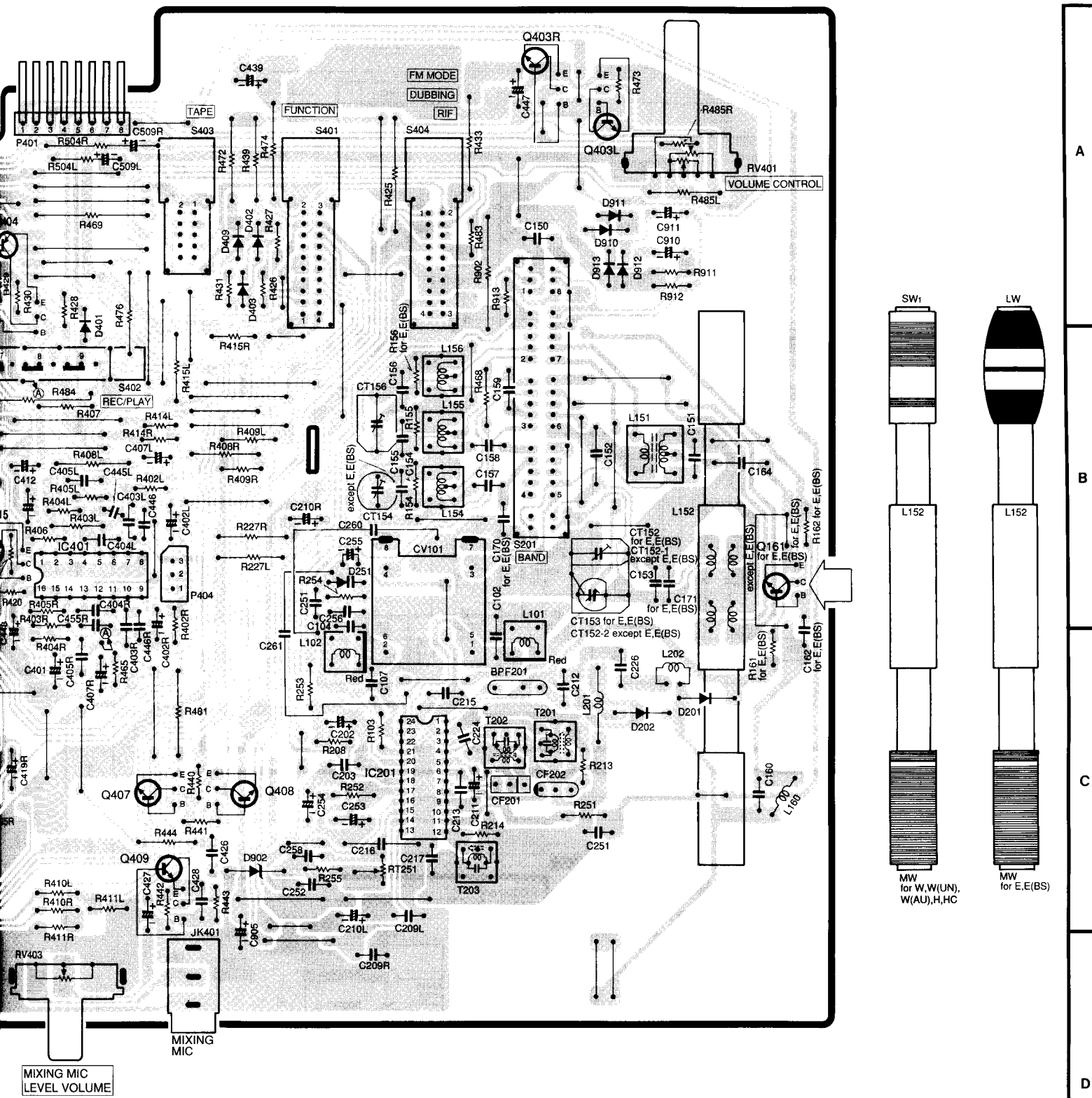

Q404 IC401 Q407 Q408 IC201 Q403R Q403L Q161
 Q415 Q409

3

4

5

G.E P.W.B.

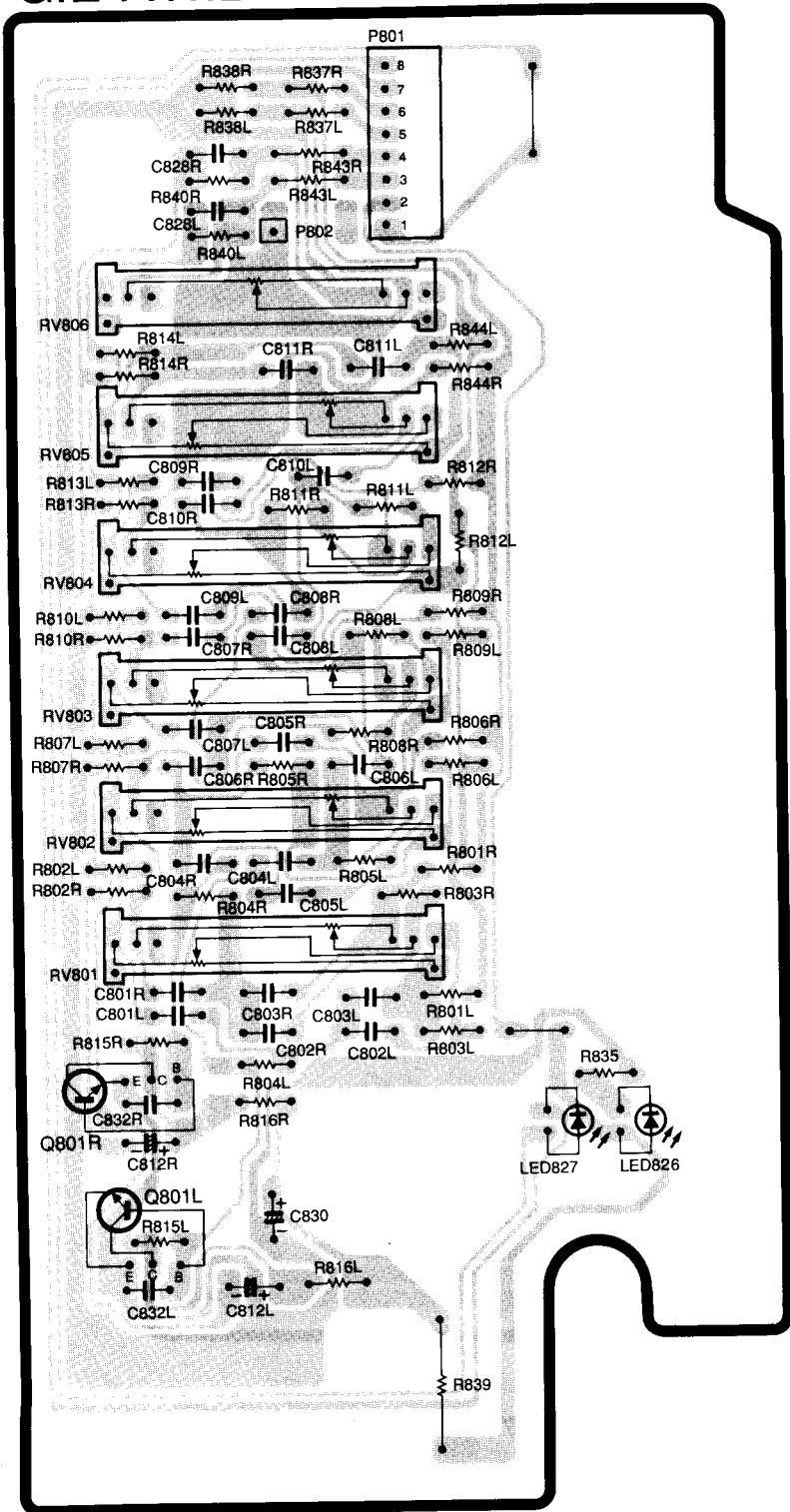

Q801R Q801L

1

2

3

for H,HC

P P.W.B.

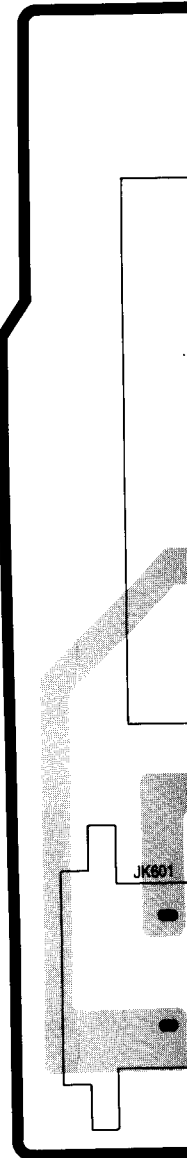

HP P.W.B.

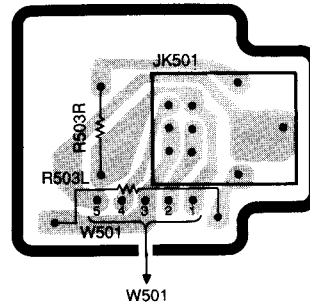

for H,HC
P P.W.B.

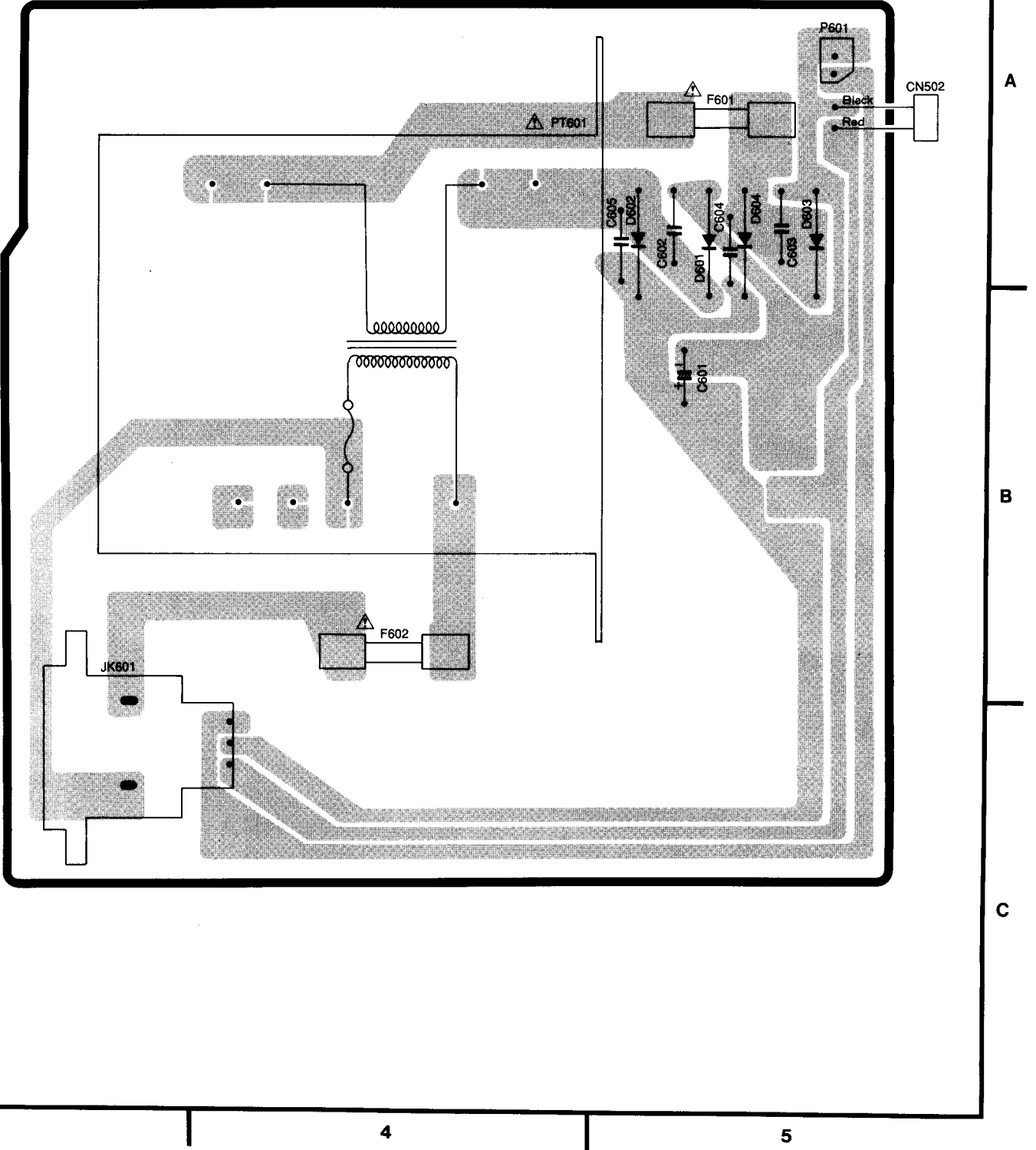

W.B.



for E,E(BS)

P P.W.B.

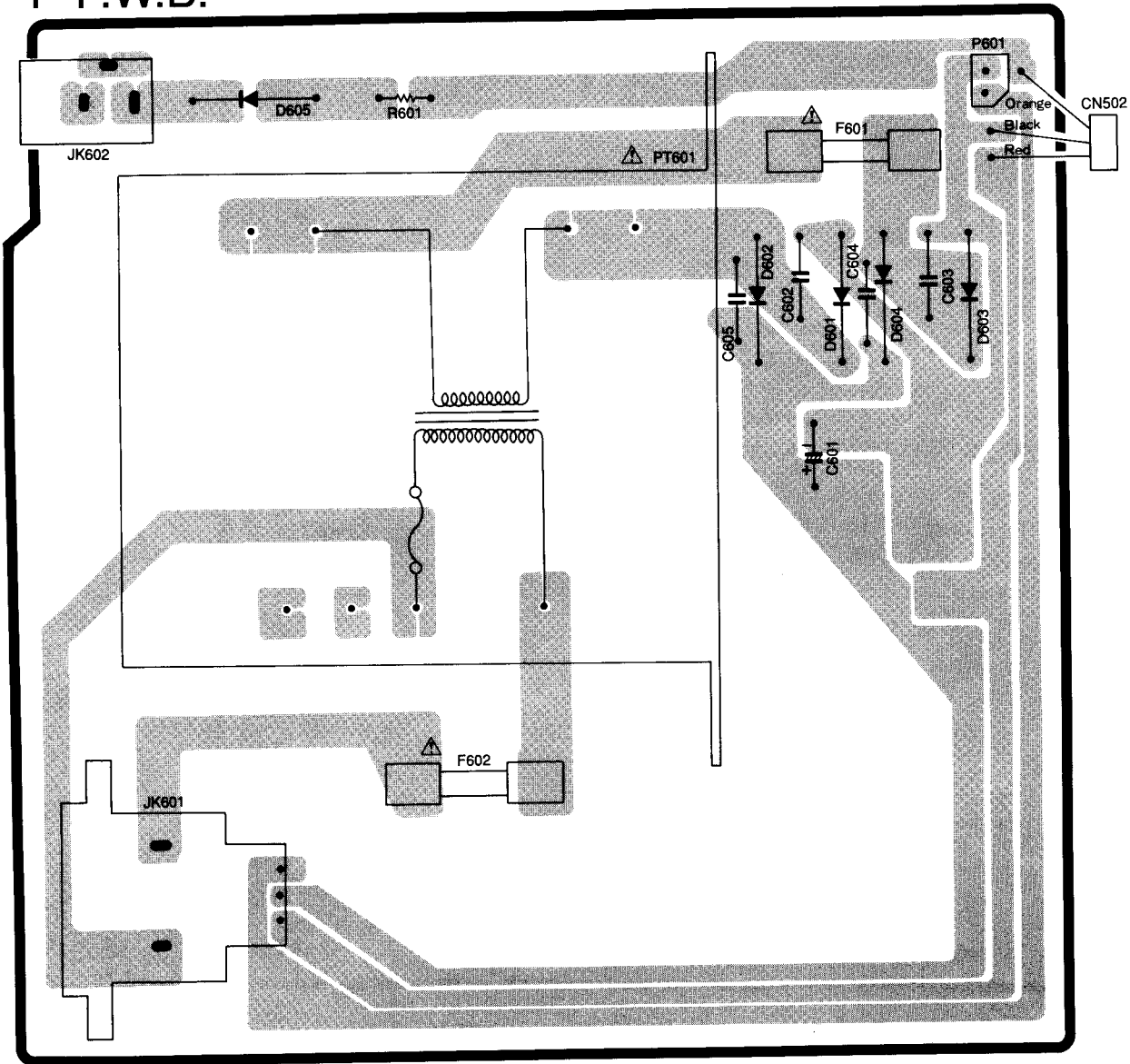

for W,W(UN),W

P P.W.

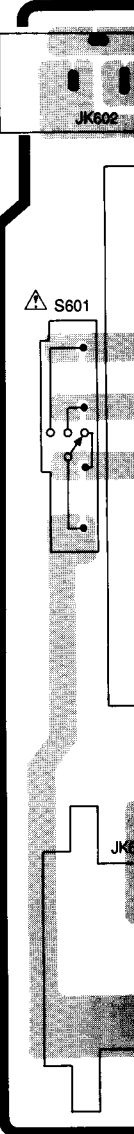

1

2

3

WIRING DIAGRAM • SCHEMA DE CABLAGE

P P.W.B.

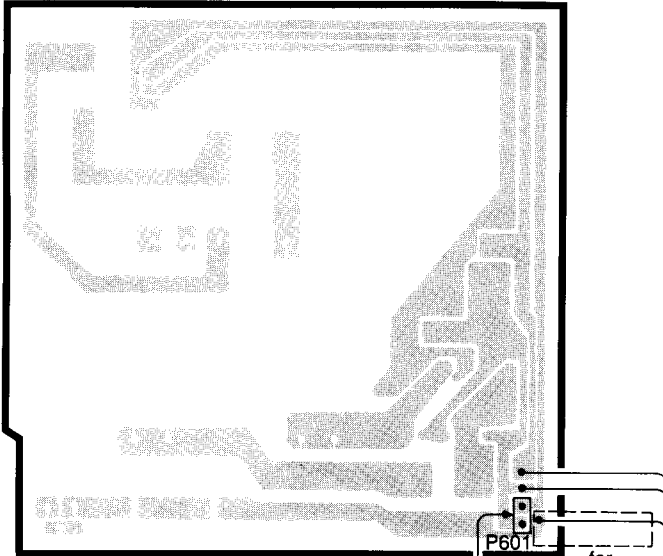

G.E. P.W.B.

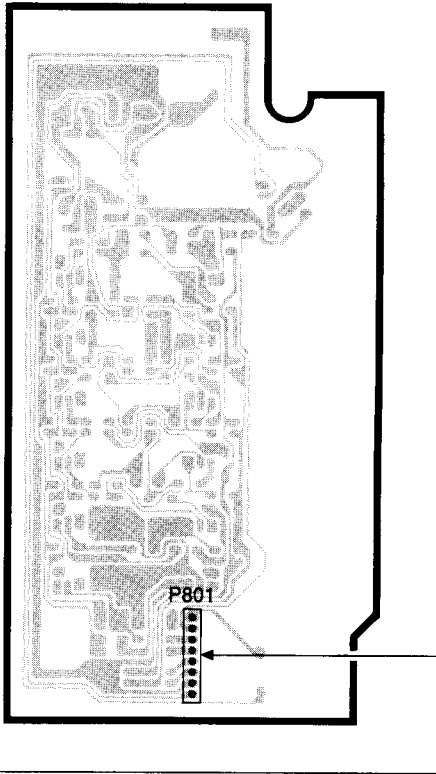

HP P.W.B.

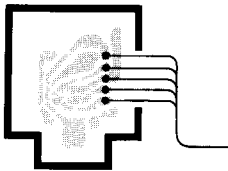

CN502

CN501

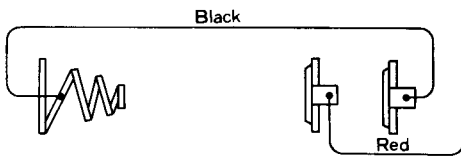

BATT. SPRING

BATT. Terminal

BATT. SPRING

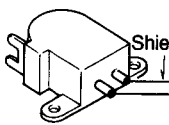
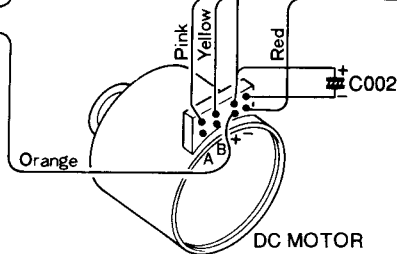
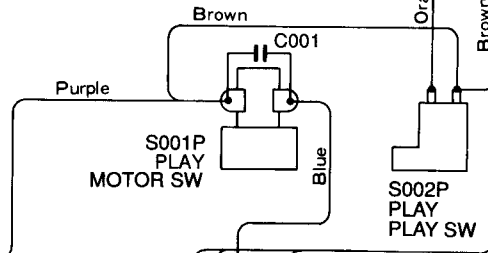
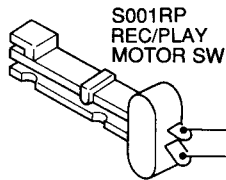
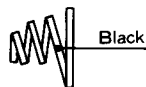

HP P.W.B.

M P.W.B.

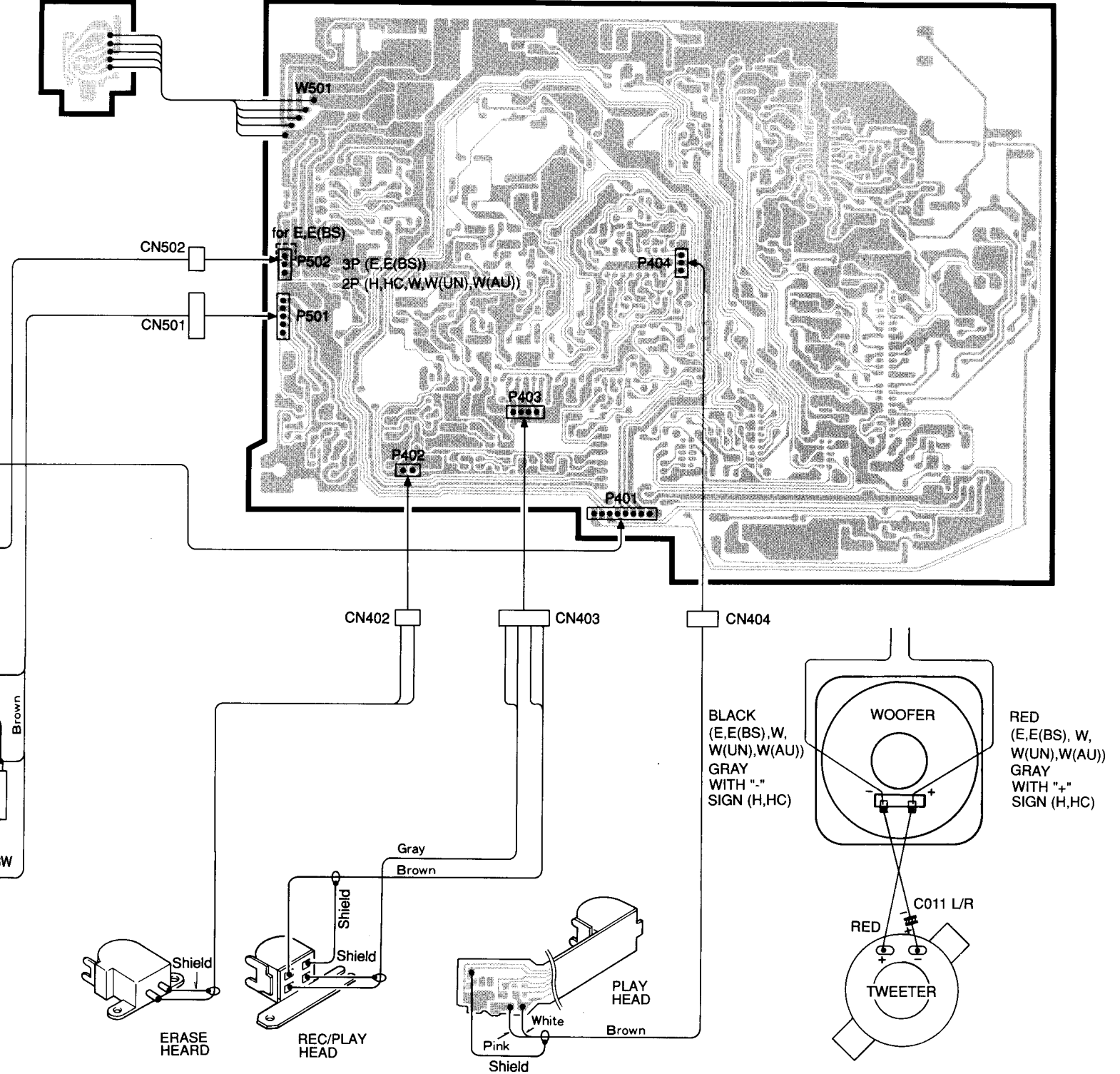

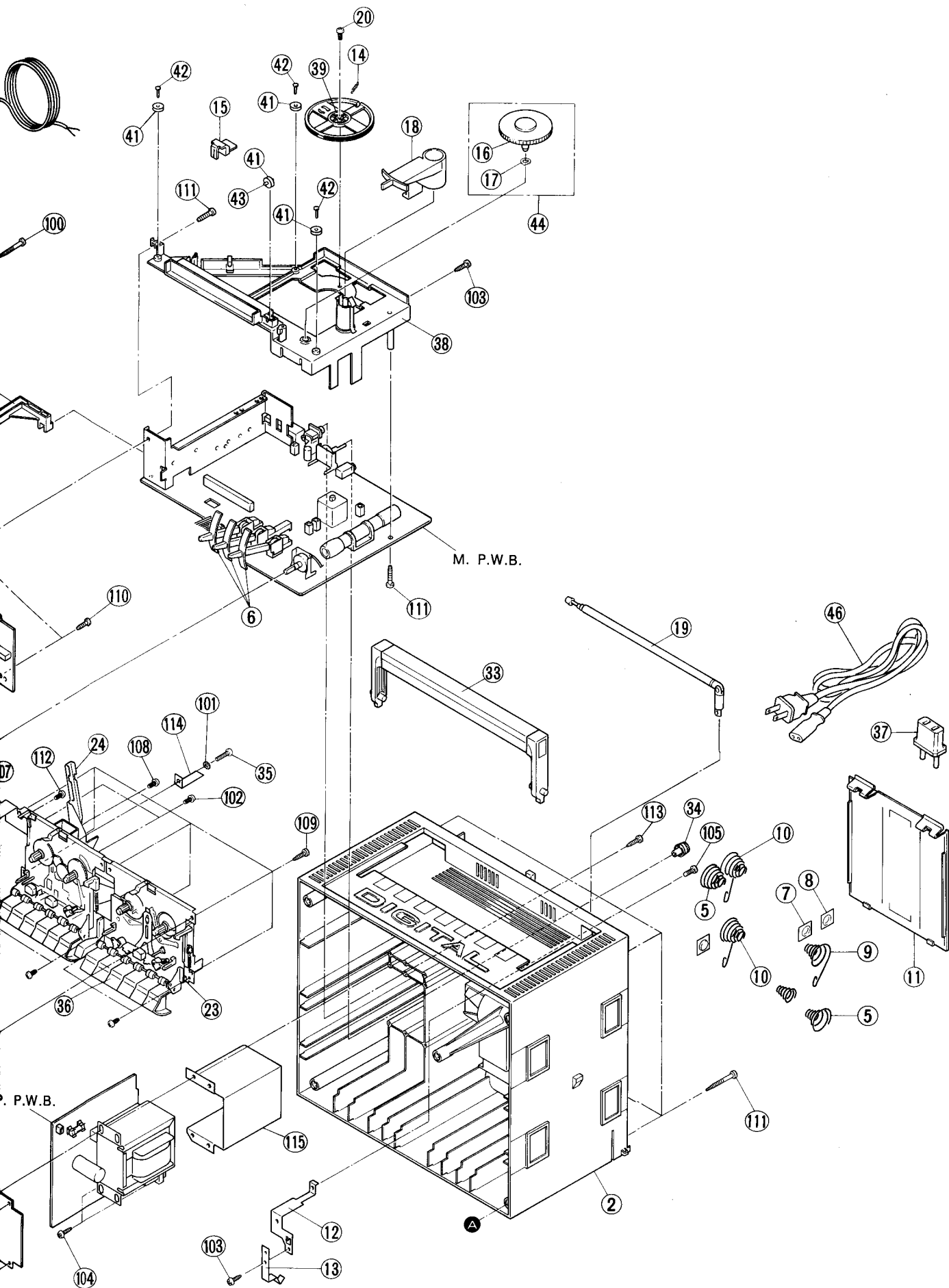

- **Cassette Chassis**
- **Châssis de Cassette**

Nos. are reference Nos. of parts list.
Les numéros se réfèrent à la list de pièces

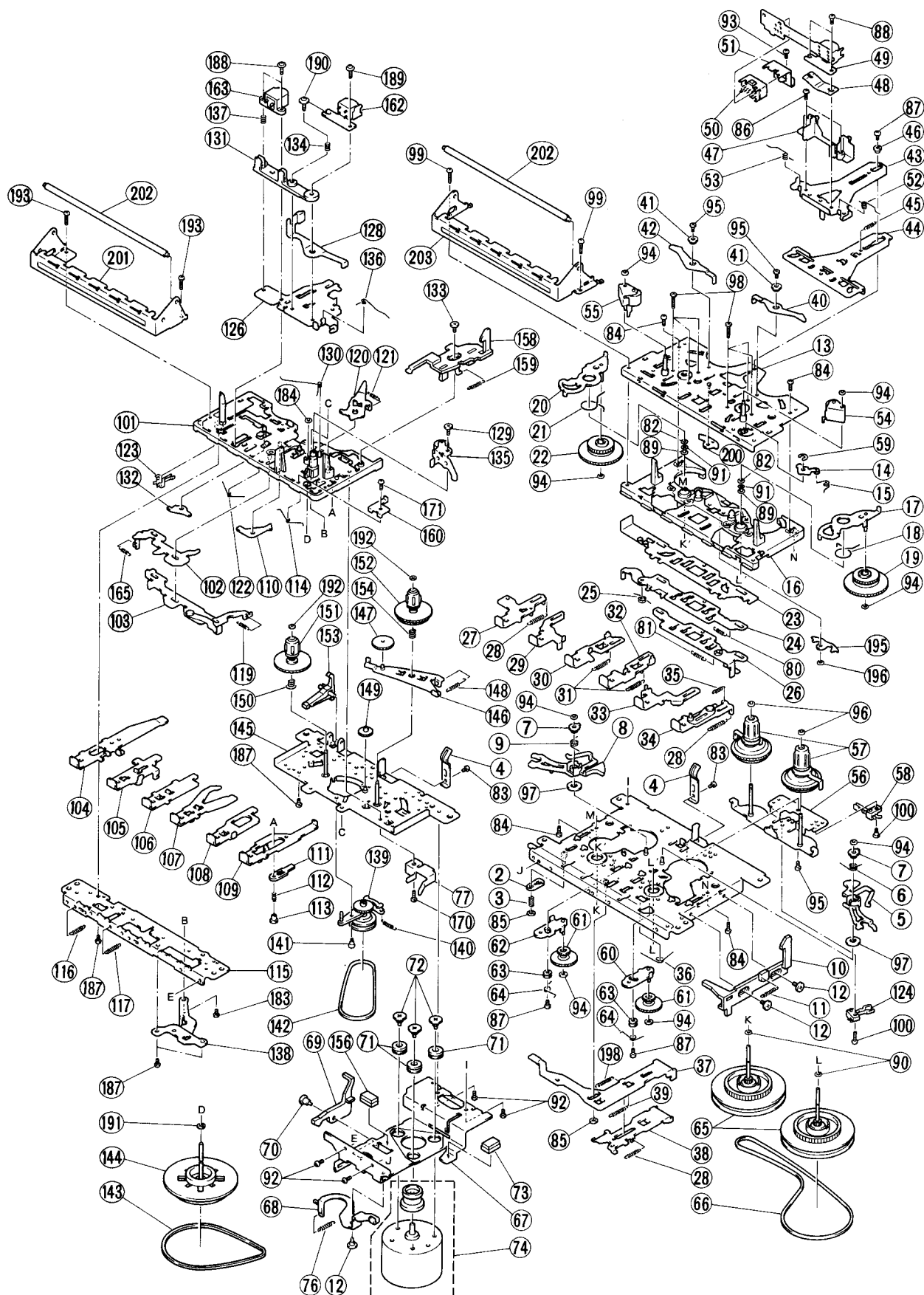

REPLACEMENT PARTS LIST

PRODUCT SAFETY NOTE: Components marked with a  have special characteristics important to safety. Before replacing any of these components, read carefully, the PRODUCT SAFETY NOTICE of this Service Manual. Don't degrade the safety of the receiver through improper servicing.

ABBREVIATIONS: Capacitors CC: Cylindrical ceramic, CD: Ceramic discal, PF: Polyester film, EL: Electrolytic,
 Resistors CF: Carbon film, CC: Carbon composition, MF: Metal oxide film,
 Semiconductor TR: Transistor, DI: Diode, ZD: Zener diode
 VA: Varistor, TH: Thermistor, IC: IC

SYMBOL NO.	PARTS NO.	DESCRIPTION	SYMBOL NO.	PARTS NO.	DESCRIPTION
CAPACITORS;			C203	0209731	CD 1000PF ±10% 50V
C001	0244171	CD 0.01μF ^{+80%} _{-20%} 50V	C209L, R	0209762	CD 0.15μF ±20% 25V
C002	0800009	EL 4.7μF 25V	C210L, R	0800003	EL 1μF 50V
C011L, R	0800015	EL 10μF 16V	C211	0800022	EL 22μF 10V
C102	0230621	CD 24PF ±5% 50V	C212	0890011	CD 15PF ±5% 50V
C104	0246448	CD 22PF ±5% 50V	C213	0890044	CD 0.022μF ^{+80%} _{-20%} 25V
C107	0246444	CD 15PF ±5% 50V	C215	0890044	CD 0.022μF ^{+80%} _{-20%} 25V
C150	0208684	CD 100PF ±5% 50V	C216	0890022	CD 100PF ±10% 50V
C151	0890012	CD 18PF ±20% 50V	C217	0880014	PF 0.047μF ±10% 50V
C151	0890004	CD 3.3PF ±10% 50V [for E, E(BS)]	C224	0240216	CD 0.022μF ±10% 25V
C152	0890009	CD 12PF ±5% 50V [except E, E(BS)]	C226	0890005	CD 4.7PF ±10% 50V
C152	0890008	CD 10PF ±5% 50V [for E, E(BS)]	C251	0890022	CD 100PF ±10% 50V
C153	0890021	CD 82PF ±10% 50V [except E, E(BS)]	C252	0240224	CD 0.1μF ±10% 25V
C153	0890008	CD 10PF ±5% 50V [for E, E(BS)]	C253	0800007	EL 3.3μF 50V
C154	0890007	CD 8.2PF ±10% 50V [except E, E(BS)]	C254	0800003	EL 1μF 50V
C154	0890012	CD 18PF ±20% 50V [for E, E(BS)]	C255	0800001	EL 0.47μF 50V
C155	0890012	CD 18PF ±20% 50V [except E, E(BS)]	C256	0230648	CD 4.7PF ±10% 50V
C155	0890011	CD 15PF ±5% 50V [for E, E(BS)]	C257	0248684	CD 100PF ±5% 50V
C156	0890013	CD 22PF ±20% 50V [except E, E(BS)]	C258	0880003	PF 1000PF ±10% 50V
C156	0890011	CD 15PF ±5% 50V [for E, E(BS)]	C401	0800056	EL 220μF 6.3V
C157	1221391	ST 180PF ±5% 50V [except E, E(BS)]	C402L, R	0800039	EL 47μF 10V
C157	0268321	PP 360PF ±5% 100V [for E, E(BS)]	C403L, R	0890034	CD 820PF ±10% 50V
C158	0268321	PP 360PF ±5% 100V [except E, E(BS)]	C404L, R	0890034	CD 820PF ±10% 50V
C158	0268442	PP 1500PF ±5% 100V [for E, E(BS)]	C405L, R	0890043	CD 0.01μF ±20% 16V
C159	0880009	PF 0.01μF ±10% 50V	C406	0800048	EL 100μF 10V
C160	0890005	CD 4.7PF ±10% 50V	C407L, R	0800007	EL 3.3μF 50V
C162	0209731	CD 1000PF ±10% 50V [for E, E(BS)]	C410	0800049	EL 100μF 16V
C164	0890043	CD 0.01μF ±20% 16V	C411	0268435	PF 0.015μF ±5% 100V
C170	0208686	CD 120PF ±5% 50V [for E, E(BS)]	C412	0800007	EL 3.3μF 50V
C202	0800003	EL 1μF 50V	C413	0800074	EL 470μF 16V
			C419L, R	0800015	EL 10μF 16V
			C420L, R	0890035	CD 1000PF ±10% 50V
			C421L, R	0800003	EL 1μF 50V
			C422L, R	0800003	EL 1μF 50V
			C426	0209175	CD 0.047μF ^{+80%} _{-20%} 50V
			C427	0800001	EL 0.47μF 50V
			C428	0890039	CD 4700PF ±30% 16V
			C429L, R	0240215	CD 0.018μF ±10% 25V
			C430L, R	0209737	CD 0.01μF ±10% 50V
			C432L, R	0890026	CD 220PF ±10% 50V
			C433L, R	02528032	EL 0.33μF 50V
			C434	0890041	CD 6800PF ±30% 16V
			C435	0890036	CD 1500PF ±20% 50V
			C436	0209762	CD 0.15μF ±20% 25V
			C437	0800048	EL 100μF 10V
			C439	0800015	EL 10μF 16V
			C440L, R	0208684	CD 100PF ±5% 50V
			C441L, R	0800003	EL 1μF 50V
			C444	0890044	CD 0.022μF ^{+80%} _{-20%} 25V

SYMBOL NO.	PARTS NO.	DESCRIPTION			SYMBOL NO.	PARTS NO.	DESCRIPTION				
C445L, R	0248688	CD	150PF	±5%	50V	R407	0700063	CF	47KΩ	±5%	1/16W
C446L, R	0248688	CD	150PF	±5%	50V	R408L, R	0700051	CF	5.6KΩ	±5%	1/16W
C448	0800015	EL	10μF		16V	R409L, R	0700061	CF	33KΩ	±5%	1/16W
C501	0800083	EL	1000μF		25V	R410L, R	0700061	CF	33KΩ	±5%	1/16W
C502L, R	0800049	EL	100μF		16V	R411L, R	0700051	CF	5.6KΩ	±5%	1/16W
C503L, R	0800016	PF	0.1μF	±10%	50V	R412	0700032	CF	220Ω	±5%	1/16W
C504L, R	0800082	EL	1000μF		16V	R413	0700049	CF	4.7KΩ	±5%	1/16W
C505L, R	0800047	EL	100μF		6.3V	R414L, R	0700059	CF	27KΩ	±5%	1/16W
C506	0800024	EL	22μF		25V	R415L, R	0700067	CF	100KΩ	±5%	1/16W
C507L, R	0890028	CD	330PF	±10%	50V	R417	0700062	CF	39KΩ	±5%	1/16W
C508	0800051	EL	100μF		25V	R418L, R	0700021	CF	33Ω	±5%	1/16W
C515	0800059	EL	220μF		25V	R419	0700061	CF	33KΩ	±5%	1/16W
C516	0890044	CD	0.022μF	+80% -20%	25V	R420	0700054	CF	10KΩ	±5%	1/16W
C517	0800051	EL	100μF		25V	R423L, R	0700052	CF	6.8KΩ	±5%	1/16W
C518	0800009	EL	4.7μF		25V	R425	0700068	CF	120KΩ	±5%	1/16W
C601	0252642	EL	2200μF		25V	R426	0700058	CF	22KΩ	±5%	1/16W
C602	0244173	CD	0.022μF	+80% -20%	50V	R427	0700058	CF	22KΩ	±5%	1/16W
C603	0244173	CD	0.022μF	+80% -20%	50V	R428	0700058	CF	22KΩ	±5%	1/16W
C604	0244173	CD	0.022μF	+80% -20%	50V	R429	0700061	CF	33KΩ	±5%	1/16W
C605	0244173	CD	0.022μF	+80% -20%	50V	R430	0700061	CF	33KΩ	±5%	1/16W
C801L, R	0890041	CD	6800PF	±30%	16V	R431	0700058	CF	22KΩ	±5%	1/16W
C802L, R	0209175	CD	0.047μF	+80% -20%	50V	R432	0129563	CF	120Ω	±5%	1/4W
C803L, R	0890041	CD	6800PF	±30%	16V	R439	0700058	CF	22KΩ	±5%	1/16W
C804L, R	0890044	CD	0.022μF	+80% -20%	25V	R440	0700058	CF	22KΩ	±5%	1/16W
C805L, R	0890039	CD	4700PF	±30%	16V	R441	0700058	CF	22KΩ	±5%	1/16W
C806L, R	0890044	CD	0.022μF	+80% -20%	25V	R442	0700005	CF	2.2Ω	±5%	1/16W
C807L, R	0890038	CD	3300PF	±20%	16V	R443	0700078	CF	680KΩ	±5%	1/16W
C808L, R	0890043	CD	0.01μF	±20%	16V	R444	0700046	CF	2.7KΩ	±5%	1/16W
C809L, R	0890036	CD	1500PF	±20%	16V	R452L, R	0700052	CF	6.8KΩ	±5%	1/16W
C810L, R	0890041	CD	6800PF	±30%	16V	R455L, R	0700072	CF	220KΩ	±5%	1/16W
C811L, R	0890026	CD	220PF	±10%	50V	R456L, R	0700028	CF	120Ω	±5%	1/16W
C812L, R	0800015	EL	10μF		16V	R457L, R	0700039	CF	820Ω	±5%	1/16W
C828L, R	0890039	CD	4700PF	±30%	16V	R458L, R	0700045	CF	2.2KΩ	±5%	1/16W
C830	0800048	EL	100μF		10V	R459L, R	0700047	CF	3.3KΩ	±5%	1/16W
C832L	0240067	CD	0.047μF	+80% -20%	50V	R460	0700032	CF	220Ω	±5%	1/16W
C905	0800057	EL	220μF		10V	R461L, R	0700079	CF	820KΩ	±5%	1/16W
C910	0800009	EL	4.7μF		25V	R463	0700014	CF	10Ω	±5%	1/16W
C911	0800009	EL	4.7μF		25V	R464	0700059	CF	27KΩ	±5%	1/16W
RESISTORS;											
R103	0700016	CF	15Ω	±5%	1/16W	R465	0700067	CF	100KΩ	±5%	1/16W
R154	0700053	CF	8.2KΩ	±5%	1/16W	R466	0700054	CF	10KΩ	±5%	1/16W
		[except E, E(BS)]				R467	0700027	CF	100Ω	±5%	1/16W
R155	0700056	CF	15KΩ	±5%	1/16W	R468	0700027	CF	100Ω	±5%	1/16W
		[for E, E(BS)]				R469	0129569	CF	220Ω	±5%	1/4W
R161	0700027	CF	100Ω	±5%	1/16W	R470	1129573	CF	330Ω	±5%	1/4W
		[for E, E(BS)]				R472	0700058	CF	22KΩ	±5%	1/16W
R162	0700074	CF	330KΩ	±5%	1/16W	R473	0700063	CF	47KΩ	±5%	1/16W
		[for E, E(BS)]				R474	0700054	CF	10KΩ	±5%	1/16W
R213	0700031	CF	180Ω	±5%	1/16W	R476	0700049	CF	4.7KΩ	±5%	1/16W
R214	0700056	CF	15KΩ	±5%	1/16W	R477L, R	0700043	CF	1.5KΩ	±5%	1/16W
R227L, R	0700067	CF	100KΩ	±5%	1/16W	R478L, R	0700057	CF	18KΩ	±5%	1/16W
R251	0700045	CF	2.2KΩ	±5%	1/16W	R481	0700041	CF	1KΩ	±5%	1/16W
R252	0700041	CF	1KΩ	±5%	1/16W	R482L, R	0700041	CF	1KΩ	±5%	1/16W
R253	0700061	CF	33KΩ	±5%	1/16W	R483	0700041	CF	1KΩ	±5%	1/16W
R254	0700061	CF	33KΩ	±5%	1/16W	R484	0700054	CF	10KΩ	±5%	1/16W
R255	0700054	CF	10KΩ	±5%	1/16W	R485L, R	0700063	CF	47KΩ	±5%	1/16W
R401L, R	0700067	CF	100KΩ	±5%	1/16W	R501L, R	0700005	CF	2.2Ω	±5%	1/16W
R402L, R	0700027	CF	100Ω	±5%	1/16W	R502L, R	0700024	CF	56KΩ	±5%	1/16W
R403L, R	0700074	CF	330KΩ	±5%	1/16W	R503L, R	01132902	CF	180Ω	±5%	1/2W
R404L, R	0700055	CF	12KΩ	±5%	1/16W	R504L, R	0700041	CF	1KΩ	±5%	1/16W
R405L, R	0700057	CF	18KΩ	±5%	1/16W	R505	0700043	CF	1.5KΩ	±5%	1/16W
R406	0700061	CF	33KΩ	±5%	1/16W	R506	0700049	CF	4.7KΩ	±5%	1/16W
						R508	0700068	CF	120KΩ	±5%	1/16W
						R511	0700038	CF	680Ω	±5%	1/16W
						R512	0700038	CF	680Ω	±5%	1/16W

SYMBOL NO.	PARTS NO.	DESCRIPTION
R515	0700041	CF 1KΩ ±5% 1/16W
R516	0700041	CF 1KΩ ±5% 1/16W
R801L, R	0700055	CF 12KΩ ±5% 1/16W
R802L, R	0700055	CF 12KΩ ±5% 1/16W
R803L, R	0700075	CF 390KΩ ±5% 1/16W
R804L, R	0700059	CF 27KΩ ±5% 1/16W
R805L, R	0700049	CF 4.7KΩ ±5% 1/16W
R806L, R	0700054	CF 10KΩ ±5% 1/16W
R807L, R	0700054	CF 10KΩ ±5% 1/16W
R808L, R	0700053	CF 8.2KΩ ±5% 1/16W
R809L, R	0700053	CF 8.2KΩ ±5% 1/16W
R810L, R	0700053	CF 8.2KΩ ±5% 1/16W
R811L, R	0700051	CF 5.6KΩ ±5% 1/16W
R812L, R	0700051	CF 5.6KΩ ±5% 1/16W
R813L, R	0700051	CF 5.6KΩ ±5% 1/16W
R814L, R	0700053	CF 8.2KΩ ±5% 1/16W
R815L, R	0700079	CF 820KΩ ±5% 1/16W
R816L, R	0700049	CF 4.7KΩ ±5% 1/16W
R835	0700038	CF 680Ω ±5% 1/16W
R837L, R	0700048	CF 3.9KΩ ±5% 1/16W
R838L, R	0700044	CF 1.8KΩ ±5% 1/16W
R839	0700032	CF 220Ω ±5% 1/16W
R840L, R	0700056	CF 15KΩ ±5% 1/16W
R843L, R	0700037	CF 560Ω ±5% 1/16W
R902	0119412	MF 82KΩ ±10% 1W
R911	0700061	CF 33KΩ ±5% 1/16W
R912	0700061	CF 33KΩ ±5% 1/16W
R913	0700049	CF 4.7KΩ ±5% 1/16W
ICS;		
IC201	2385323	IC TA8167N
IC401	23011912	IC TA7784P
IC501	23008722	IC μPC1335V
TRANSISTORS;		
Q161	2319083	TR HIT9011GH [for E, E(BS)]
Q402L, R	2329453	TR 2SC945P
Q403L, R	2329453	TR 2SC945P
Q404	23280832	TR 2SA844E
Q407	2329453	TR 2SC945P
Q408	2329453	TR 2SC945P
Q409	2319091	TR HIT9014N (C)
Q410L, R	2329453	TR 2SC945P
Q412	2317782	TR 2SC2235 (Y)
Q413L, R	2329453	TR 2SC945P
Q414	2319052	TR HIT8050C
Q415	2329453	TR 2SC945P
Q501	2318433	TR 2SD2061 (F)
Q502	2318433	TR 2SD2061 (F)
Q503	23280832	TR 2SA844E
Q504	2329453	TR 2SC945P
Q801L, R	2329453	TR 2SC945P
DIODES;		
D201	2398921	DI 1N4531T
D202	2398921	DI 1N4531T
D251	23380312	DI 1S2790
D401	2398921	DI 1N4531T
D402	2398921	DI 1N4531T
D403	2398921	DI 1N4531T
D409	2398921	DI 1N4531T

SYMBOL NO.	PARTS NO.	DESCRIPTION
D501	23375552	DI HZ11B-2
D502	23375692	DI HZ12C-3
D504	23375552	DI HZ11B-2
D601	2398823	DI RL253
D602	2398823	DI RL253
D603	2398823	DI RL253
D604	2398823	DI RL253
D902	23375172	DI HZ6C-1
D910	2398921	DI 1N4531T
D911	2398921	DI 1N4531T
D912	2398921	DI 1N4531T
D913	2398921	DI 1N4531T
LED826	2397311	LED TLR-208
LED827	2397311	LED TLR-208
VARIABLE CAPACITOR;		
CV101	0282402	VARIABLE CAPACITOR
VARIABLE RESISTORS;		
RT251	0189332	VR 10KΩ
RT501	0158923	VR 2KΩ
RV401	0166945	VR 50KΩ
RV403	0159941	VR 10KΩ
RV801	0189121	VR 100KΩ
RV802	0189121	VR 100KΩ
RV803	0189121	VR 100KΩ
RV804	0189121	VR 100KΩ
RV805	0189121	VR 100KΩ
RV806	0189122	VR 50KΩ
TRANSFORMERS;		
T201	2154962	FM IF TRANSFORMER
T202	2137871	AM IF TRANSFORMER
T203	2154961	FM IF TRANSFORMER
T401	2136823	BIAS OSC COIL (85kHz)
FUSES;		
△ F601	2727725	FUSE (4A, 250V)
△ F602	2728072	FUSE (630mA)
COILS;		
L101	2138084	FM RF COIL
L102	2138081	FM OSC COIL
L151	2137662	SW ANT COIL [for E, E(BS)]
L151	2137667	ANTENNA COIL [except E, E(BS)]
L154	2137632	LW OSC COIL [for E, E(BS)]
L154	2137631	MW OSC COIL [except E, E(BS)]
L155	2137631	MW OSC COIL [for E, E(BS)]
L155	2137633	SW OSC COIL [except E, E(BS)]
L156	2137671	SW OSC COIL [for E, E(BS)]
L156	2137672	SW OSC COIL [except E, E(BS)]
L160	2137684	CHOKE COIL 0.45 MICRO H
L201	2227922	CHOKE COIL 22 MICRO H
L202	2227721	FM TRAP COIL
L401L, R	2227991	CHOKE COIL 3.3 MICRO H
L402L, R	2228611	CHOKE COIL 33 MICRO H

SYMBOL NO.	PARTS NO.	DESCRIPTION	SYMBOL NO.	PARTS NO.	DESCRIPTION
MISCELLANEOUS;					
BPF201	2137193	FM BAND PASS FILTER	8	4436663	TERMINAL
CF201	2155491	CERAMIC FILTER [for E, E(BS)]	9	3367065	SPRING
CF201	2155492	CERAMIC FILTER [except E, E(BS)]	10	3367064	SPRING
CF202	2135321	CERAMIC FILTER	11	3950093	BATTERY COVER
CT152	0283113	CAPACITOR VARIABLE [for E, E(BS)]	12	4480741	ANT TERMINAL
CT152	0283557	TRIMMER	13	4480771	ANT SPRING
CT153	0282148	CAPACITOR SEMI VARIABLE [for E, E(BS)]	14	3340322	SPRING M
CT154	0282148	CAPACITOR SEMI VARIABLE	15	3975431	POINTER
CT156	0283113	CAPACITOR VARIABLE	16	3295294	TUN KNOB
S201	2628551	SLIDE SWITCH	17	3340312	SPRING WASHER
S401	2628001	SWITCH, LEVER	18	3309391	BAND KNOB
S402	2629296	SW-SL9-2	19	2757901	ROD ANTENNA
S403	2628486	LEVER SWITCH	20	0711306	SCREW, PAN HAND 2.6x6
S404	2628485	LEVER SWITCH	21	3950381	DAMPER ASSY
△ S501	2600153	POWER SWITCH	22	3368685	EJECT SPRING
S601	2618472	SWITCH [for W, W(UN), W(AU)]	23	2589541	TN-521Z MECHA
E601	2727832	FUSE HOLDER	24	4480761	REC LEVER
JK401	2679371	3.5 JACK	25	3809781	SPEAKER BOX
JK402	2678152	2P PIN JACK	26	2404142	SPEAKER 16
JK501	2678761	STEREO JACK	27	2404232	TWEETER 5
JK502	2689551	4P PUSH TERMINAL	28	3238152	BUFFLE PANEL TAS
△ JK601	26592742	2P SOCKET [for H, HC]	29	4578972	BT FLANGE SCREW, (3x10)
△ JK601	26592712	2P SOCKET [except H, HC]	30	3810844	CASSETTE DOOR L SASS
△ JK602	2678881	DC JACK [for E, E(BS)]	31	3810843	CASSETTE DOOR R SASS
△ JK602	2678882	DC JACK [for W, W(UN), W(AU)]	32	3309411	VOL. KNOB
L152	2757993	FERRITE ANTENNA [for E, E(BS)]	33	4006751	HANDLE ASSY
L152	2757981	FERRITE ANTENNA [except E, E(BS)]	34	3800862	KNOB
	8671408	DT BIND HEAD SCREW (3x8)	35	8741104	2x4 B.H. SCREW
	3814881	LED SPACER	36	3309451	CASSETTE BUTTON
△ PT601	2249814	POWER TRANSFORMER (1.12KG 42.9VA) [for H, HC]	37	26679222	SIEMEN PLUG [for W, W(UN)]
△ PT601	2249811	POWER TRANSFORMER (1.12KG 42.9VA) [for E]	38	4006761	DIAL HOLDER SUB ASSY
△ PT601	2249812	POWER TRANSFORMER (1.12KG 42.9VA) [for E(BS)]	39	3975391	PULLEY
△ PT601	2249813	POWER TRANSFORMER (1.12KG 42.9VA) [for W, W(UN), W(AU)]	40	3814541	GE PIECE
			41	3934271	ROLLER
			42	4577661	ROLLER PIN
			43	4583855	RIBET (2X7)
			44	4006771	TUNING KNOB TAS
			45	3812852	INSULATOR RING
			△ 46	2706591	AC POWER CORD [for H]
			△	2713141	AC POWER CORD [for H(C)]
			△	2705942	AC POWER CORD [for E]
			△	2717901	AC POWER CORD [for E(BS)]
			△	2706242	AC POWER CORD [for W, W(UN)]
			△	2713261	AC POWER CORD [for W(AU)]
			100	4577817	3x30 BT SCREW (SP. BOX x 4)
			101	8815111	LOCK WASHER
			102	48190682	M2x4 SCREW (COUNTER BRACKET x 1)
			103	8691410	3x10 BT SCREW (ANT SPRING 1)
			104	4583881	3x12 BT SCREW (3x12)
			105	8744412	3x12 BIND HEAD SCREW (ANT. 1)
			106	4578976	3x20 BT SCREW (TRANSFORMER 4)
			107	8691412	3x12 BT SCREW (DAMPER 2)
			108	4833465	SCREW (A) (REC. LEVER 1)
			109	8699412	3x12 BT SCREW B (MECHA 6)
			110	8699410	3x10 BT SCREW B (PWB 2)
			111	4577816	3x20 BT SCREW (REAR CASE 5) (HEAT SINK 1, DIAL HOLDER 1)
			112	8691408	3x8 BT SCREW (COUNTER BRACKET 1)
			113	8699408	3x8 BT SCREW B (LINE IN 1)
			114	4481572	RECORD PLATE
			115	4477482	SHIELD PLATE
CABINET CHASSIS					
1	3238141	FRONT CASE SASS [for H, HC]			
	3238142	FRONT CASE SASS [for E, E(BS)]			
	3238143	FRONT CASE SASS [for W, W(UN), W(AU)]			
2	3814711	REAR CASE SASS [for H]			
	3814712	REAR CASE SASS [for HC]			
	3814713	REAR CASE SASS [for E]			
	3814714	REAR CASE SASS [for E(BS)]			
	3814715	REAR CASE SASS [for W]			
	3814716	REAR CASE SASS [for W(UN)]			
	3814717	REAR CASE SASS [for W(AU)]			
3	3309431	KNOB P			
4	3809771	P ARM			
5	3367142	SPRING			
6	3309421	SNAP KNOB			
7	4436664	TERMINAL			

SYMBOL NO.	PARTS NO.	DESCRIPTION
CASSETTE CHASSIS		
2	48191312	PAUSE LEVER
3	48191322	PAUSE LEVER SPRING
4	4842395	PACK SPRING PLATE
5	4853652	AUTO LEVER (F)
6	4853653	AUTO LEVER (F) SPRING
7	4853654	SPRING STOPPER
8	4853655	AUTO LEVER (R)
9	4853656	AUTO LEVER (R) SPRING
10	4856321	EJECT SLIDE LEVER (1851-17-03)
11	4853658	EJECT SLIDE LEVER SPRING
12	4833465	SPECIAL SCREW
13	4853659	SUB CHASSIS ASSY
14	4853650	TURN OVER ARM
15	4853661	TURN OVER SPRING
16	4853662	BUTTON BASE ASSY
17	4853663	T GEAR ARM (F) ASSY
18	4853664	T GEAR ARM (F) SPRING
19	4853665	T-CAM GEAR (F)
20	4853666	T GEAR ARM (R) ASSY
21	4853667	T GEAR ARM (R) SPRING
22	4853668	T-CAM GEAR (R)
23	4853669	SLIDE PLATE
24	4853660	LOCK ACTUATOR ASSY
25	4853671	LOCK RELEASE SPRING
26	4853672	SW ACTUATOR ASSY
27	4856322	MODE BUTTON ASSY
28	4853674	BUTTON LEVER SPRING
29	4853675	PLAY BUTTON LEVER
30	4853676	FF BUTTON LEVER R (S)
31	4853677	FF BUTTON LEVER SPRING
32	4853678	FF BUTTON LEVER F (S)
33	4853679	STOP BUTTON LEVER (S)
34	4853670	PROGRAM BUTTON LEVER (S)
35	4853681	PULL ARM SPRING
36	4853682	STOP BUTTON LEVER SPRING
37	4853683	RELAY PLATE
38	4853684	FF SW PLATE
39	4853685	R.C. SPRING
40	4853686	AUTO CONTROL ARM (F)
41	4853687	CONTROL COLLAR
42	4853688	AUTO CONTROL ARM (R)
43	4853689	HEAD PANEL
44	4853680	R.C. PLATE
45	4853691	R.C. PLATE SPRING
46	4853692	H.P. COLLAR
47	4853693	TAPE GUIDE
48	4853694	HEAD SPRING PLATE
49	8513372	P. HEAD P-5244BA-5487
50	4842401	SLIDE SWITCH
51	4853696	SWITCH BRACKET
52	4853697	PINCH ROLLER SPRING (F)
53	4853698	PINCH ROLLER SPRING (R)
54	4853699	PINCH ROLLER (F) ASSY
55	4853690	PINCH ROLLER (R) ASSY
56	4853701	REEL PLATE ASSY
57	4853702	REEL ASSY
58	8501741	LEAF SWITCH MSW-1290CV
59	48191962	E RING
60	4853704	FF GEAR ARM (F) ASSY
61	4853705	FF GEAR
62	4853706	FF GEAR ARM (R) ASSY
63	4853707	FF GEAR ARM COLLAR

SYMBOL NO.	PARTS NO.	DESCRIPTION
64	4853708	FF GEAR ARM SPRING (F)
65	4853709	FLYWHEEL ASSY
66	4853700	MAIN BELT
67	4853711	MOTOR BRACKET
68	4853712	P KICK LEVER
69	4833463	LEVER
70	4833466	SPECIAL SCREW
71	4842404	MOTOR RUBBER
72	8511951	M. COLLER SCREW
73	4856324	FELT (1821-12-109)
74	8513377	MOTOR PASS
76	4853715	P KICK LEVER SPRING
77	4842425	PAUSE PROTECT BRACKET
80	4853716	LOCK ACTUATOR SPRING
81	4853717	SW ACTUATOR SPRING
82	8501744	P WASHER 1.75x4x0.3
83	4853719	C TAPPING SCREW, (2x3)
84	48191912	TAPPING SCREW, (2x6)
85	4842443	WASHER (2.1)
86	4853710	TAMS SCREW, (2x6)
87	4853721	CAMERA S TAPPING SCREW, (1.7x4)
88	4853722	SCREW, (2x4.5)
89	4842414	WASHER (2)
90	4842430	WASHER (2.1)
91	4853723	WASHER (1.45)
92	48190682	TAPPING SCREW, (2x4)
93	4842412	CAMERA S TAPPING SCREW, (1.7x2.5)
94	4842444	WASHER (1.2)
95	4853724	CAMERA S TAPPING SCREW, (1.7X3)
96	48190772	WASHER (1.2)
97	4853725	WASHER (3)
98	4853726	CAMERA S TAPPING SCREW, (1.7x8)
99	4856328	M2x9 SCREW (9999-13-02)
100	4856329	M2x5 SCREW (9181-00-00)
101	48189912	MAIN BASE ASSY
102	4853727	SWITCH ACTUATOR
103	4839371	PUSH BUTTON ACTUATOR ASSY
104	4823651	REC BUTTON LEVER
105	4823661	PLAY BUTTON LEVER
106	4823671	RWD BUTTON LEVER
107	4823681	FF BUTTON LEVER
108	4823691	STOP BUTTON LEVER
109	4823701	PAUSE BUTTON LEVER ASSY
110	48189902	RWD LEVER
111	48191312	PAUSE LEVER
112	48191322	PAUSE LEVER SPRING
113	48191332	PAUSE STOPPER
114	48191002	BUTTON LEVER SPRING
115	48202152	SUB CHASSIS
116	48190072	BUTTON LEVER SPRING
117	48202172	PLAY BUTTON LEVER SPRING
119	48190082	ACTUATOR SPRING
120	48190092	AUTO LEVER
121	48190002	AUTO LEVER SPRING
122	48202142	BUTTON LEVER SPRING
123	4856331	LEAF SWITCH MSW-1541T
124	8501749	LEAF SWITCH MSW-1275
126	4856332	HEAD PANEL (1829-03-04)
128	4842423	SENSING PLATE ASSY
129	4832522	SCREW

SYMBOL NO.	PARTS NO.	DESCRIPTION
130	48202212	HEAD PANEL SPRING
131	48190142	HEAD BASE
132	48190062	PR STOPPER
133	48190452	SCREW
134	48190172	SPRING
135	4839372	PINCH ROLLER ARM ASSY
136	4842424	PINCH ROLLER SPRING
137	4856333	E.H. SPRING (1821-03-08)
138	4831610	METAL GUIDE
139	4853728	RF PULLEY ARM ASSY
140	48202252	RF PULLEY ARM SPRING
141	48202262	RF ARM COLLAR SCREW
142	8513379	RF BELT
143	4853718	MAIN BELT
144	4850092	FLYWHEEL ASSY
145	4839376	REEL BASE ASSY
146	8513370	T GEAR PLATE ASSY
147	4839378	TAKE UP ROLLER GEAR
148	48190202	TG PLATE SPRING
149	4839379	FF GEAR
150	8513381	BACK TENSION SPRING
151	4842431	S REEL ASSY
152	4839381	TAKE UP REEL ASSY
153	4832421	RECORD SAFETY LEVER
154	4839382	BACK TENSION SPRING
156	4856324	FELT (1821-12-109)
158	48195352	EJECT SLIDE LEVER
159	48190442	EJECT SLIDE LEVER SPRING
160	4842433	BRACKET
162	8513383	HEAD MS15R-AA2N1
163	8513384	E HEAD LE15B-C1
165	48202182	SWITCH ACTUATOR SPRING
170	48191912	TAPPING SCREW, (2x6)
171	4842434	CAMERA TAPPING SCREW, (2x3.5)
184	48190782	WASHER (1.55)
187	48196072	BIND TAPPING SCREW, (2x5)
188	48195442	CAP SCREW (2x8)
189	48190602	SCREW, (2X7)
190	48196002	AZIMUTH SCREW
191	4832431	TAPPING BIND SCREW, (2x4)
192	4853731	WASHER (1.2)
193	48190722	SCREW, (2x7)
195	4853734	FF CONTROL ARM
196	8501740	P WASHER
198	4853732	BUTTON LEVER SPRING (P)
200	4853733	RC ARM
201	4831624	BUTTON FLAME (S) (1821-31-06)
202	8506761	BUTTON LEVER SHAFT
203	4856326	BUTTON FLAME (S) (1851-31-01)

**HITACHI SALES EUROPA GmbH**

Rungedamm 2, 2050 Hamburg 80, West Germany
Tel. 040-734 11-0

HITACHI SALES (U.K.) Ltd.

Hitachi House, Station Road, Hayes, Middlesex UB3
4DR, England
Tel. 01-848-8787

HITACHI SALES SCANDINAVIA AB

Rissneleden 8, Box 7138, 172-07 Sundbyberg, Sweden
Tel. 08-98 52 80

HITACHI SALES NORWAY A/S

P.O. Box 503, Oberebekk, 1620, Gressvik, Norway
Tel. 032-28255

SUOMEN HITACHI OY

Takojankatsu 5, 15800 Lahti 80, Finland
Tel. (918) 44 241

HITACHI SALES A/S

Kuldysen 13, DK-2630, Taastrup, Denmark
Tel. 02-999200

HITACHI SALES A.G.

Bahnhofstrasse, 19, 5600 Lenzburg, Switzerland
Tel. 064-513621

HITACHI SALES WARENHANDELS GMBH

A-1180/Wien, Kreuzgasse 27, Austria
Tel. 0222-421670

HITACHI SALES ITALIANA, S.P.A.

Via Ludovico di Breme, 9-20156 Milano Italy
Tel. (02) 30231

HITACHI SALES BELGIUM S.A./N.V.

Chaussee de Namur, 56, B-1400 Nivelles, Belgium
Tel. (3267) 21-71-81, (3267)21-79-81

HITACHI SALES IBERICA, S.A.

Gran Via Carlos Tercero, 101, 1-1, Bcelona 08028
Spain
Tel. 330-8652

**HITACHI PRODUCTIONS MAROC ELECTRONIQUES
DOMESTIQUES S.A.**

Rue du Havre, Casablanca, Morocco
Tel. 30-73-68, 30-73-57

HITACHI CANARIAS S.A.

Calle San-Francisco No. 19, 38002, SantaCruz de Tenerife
Canary Islands
Tel. 24-64-98

HITACHI SALES (HELLAS), S.A.

110 Syngrou St., Athens, Greece
Tel. 9219082, 9233469

HITACHI SALES (MALAYSIA) SDN, BHD.

Wisma Hitachi No. 2 Lorong 13/6A. 46200 Petaling
Jaya, Malaysia
Tel. 7573455

HITACHI (SINGAPORE) PTE., LTD.

18 Pasir Panjang Road #01-03 PSA
Multi-Storey Complex, Singapore 0511
Tel. 2738102

HITACHI SALES (THAILAND) LTD.

2240-46, New Petchburi Road, Bangkapi, Hueykuang
Bangkok, Thailand
Tel. 314-2741

HITACHI ELECTRIC SERVICE CO., (HONG KONG) LTD.

4th Floor Leun Tai Industrial Bldg., 72-76 Kwai Cheong
Road Kwai Chung N.T., Hong Kong
Tel. 0-242976, 0-240126

HITACHI ELECTRIC AUSTRALIA PTY LTD.

153 Keys Road, Moorabbin, Victoria 3189 Australia
Tel. 555-8722

HITACHI SALES CORPORATION OF AMERICA

Eastern Regional Office
1200 Wall Street West, Lyndhurst, New Jersey 07071,
U.S.A.
Tel. 201-935-8980

Mid-Western Regional Office

1400 Morse Ave., Elk Grove Village,
Illinois 60007, U.S.A.
Tel. 312-593-1550

Southern Regional Office

510 Plaza Drive, College Park, Georgia 30349, U.S.A.
Tel. 404-763-0360

Headquarters Western Regional Office

401 West Artesio Boulevard, Compton, California 90220
U.S.A.
Tel. 213-537-8383

HITACHI SALES CORPORATION OF HAWAII, INC.

3219 Koapaka Street, Honolulu, Hawaii 96819, U.S.A.
Tel. 808-836-3621

HITACHI (HSC) CANADA INC.

3300 Trans-Canada Highway, Pointe Claire, Quebec,
H9R 1B1, Canada
Tel. 514-697-9150

Hitachi Sales Centroamericana, S.A.

HITACHI ELECTRONICA CENTROAMERICANA, S.A.
San Rafael de Escazu, (Apartado 10272), San Jose,
Costa Rica
Tel. 28-20-11, 28-00-37

Hitachi Sales Corporation de Panama, S.A.**INTERNATIONAL HITACHI SALES PANAMA, LTD.**

PRODUCTOS HITACHI, S.A.
Apartado 7657 Panama 5 Panama City, Rep. of Panama
Tel. 61-3100, 61-4305

HITACHI-FRANCE (RADIO-TV ELECTRO-MENAGER) S.A.

95-101 Rue Charles Michels,
93200 SAINT-DENIS,
France
Tel. 4821 6015

HITACHI LTD. TOKYO JAPAN

Head Office: THE HITACHI ATAGO BLDG.
No. 15-12, 2-Chome Nishi-Shinbashi
Minato-ku, Tokyo 105, Japan
Tel. Tokyo (03) 502-2111

MS-W560 TY No. 624 EF