



IC+FET FM-AM STEREO
with 8 TRACK RECORD DECK

MODEL SP-2900

SERVICE MANUAL

No. 4 8 4

1 9 7 2

SPECIFICATIONS

RADIO & AMPLIFIER

CIRCUIT SYSTEM.....FM/AM superheterodyne with
FM multiplex stereo adaptor and
with 8-track tape recorder deck

TUNING RANGE.....FM: 88~108MHz
MW: 530~1,605kHz

INTERMEDIATE FREQUENCY...FM: 10.7MHz
AM: 455kHz

IC

IC201 TRM1205.....FM IF Amp. & AM Conv.
IC202 TRM1212.....FM/AM IF Amp.
IC301 SN76110.....MPX
IC401 FA6016.....AF Amp.
IC501A HA1308 }
IC501B HA1308 }Power Amp.
IC801A FA6018 }
IC801B FA6018 }Pre amp.
IC802A FA6019 }
IC802B FA6019 }Pre amp.

TRANSISTORS

TR101 2SK37.....FM RF Amp.
TR102 2SC535.....FM Conv.
TR801 2RC1213 }
TR802 2SC1213 }Bias osc.

DIODES

D101 1N60.....FM Limit.
D102 1S85.....AFC
D151 HV80.....AGC
D201 HV80.....FM Limit.
D202 1N60P }
D203 1N60P }FM Det.
D204 1N34A.....AM Det.
D205 1N60.....FM Det. (for TUNING METER)
D206 1N60.....AM Det. (for TUNING METER)
D601 AW01-13.....Volt. Stab.
D801A 1N34A }
D801B 1N34A }Rectifier (for LEVEL METER)
D802A 1N34A }
D802B 1N34A }

D803 WO6A.....Protector (RELAY)
D804 WO6A }
D805 VO6C }Obstruct of reverse current
D806 VO6C.....SWITCHING
D807Protector
Z601 SV01A }
Z602 SV01A }Rectifier
Z603 SV01A }
Z604 SV01A }

SPEAKER.....6½" (16cm)PM, 8 ohm×2 (Woofer)
2" (5cm) PM, 8 ohm×2 (Tweeter)

AUDIO OUTPUT.....20W (PMP)

POWER SUPPLY.....AC 120V, 60Hz

POWER CONSUMPTION.....60W

ANTENNA.....FM: Line cord antenna
AM: Ferrite core antenna

SENSITIVITY.....(max.) (practical)

FM: 3μV 7μV
AM: 200μV/m 250μV/m

TERMINALS.....● Stereo head phone jack
● Mic. jacks
● FM ANTENNA TERMINALS
● AUX IN JACKS
● REC. JACKS
● SPEAKER JACKS

TAPE DECK

TRACK SYSTEM.....8-track 2-channel stereo.

RECORDING SYSTEM.....AC bias

ERASING SYSTEM.....AC bias

TAPE SPEED.....3¾ ips (9.5cm/s)

TAPE.....8-track 2-channel 4 program

MOTOR.....DC motor (with gaverner)

TAPE CHANGE SYSTEM.....Automatic/manual push button

DIMENSIONS.....TUNER: 5"(H)×20⅝"(W)×11⅝"(D)
(12.6×53.2×30.3cm)
SP. BOX: (14"(H)×9½"(W)×5½"(D)×2
(35.5×24.0×14.0cm)

WEIGHT.....TUNER: 15 lbs. (6.8kg)
SP. BOX: 4 lbs. (1.9kg)×2

CONTROLS

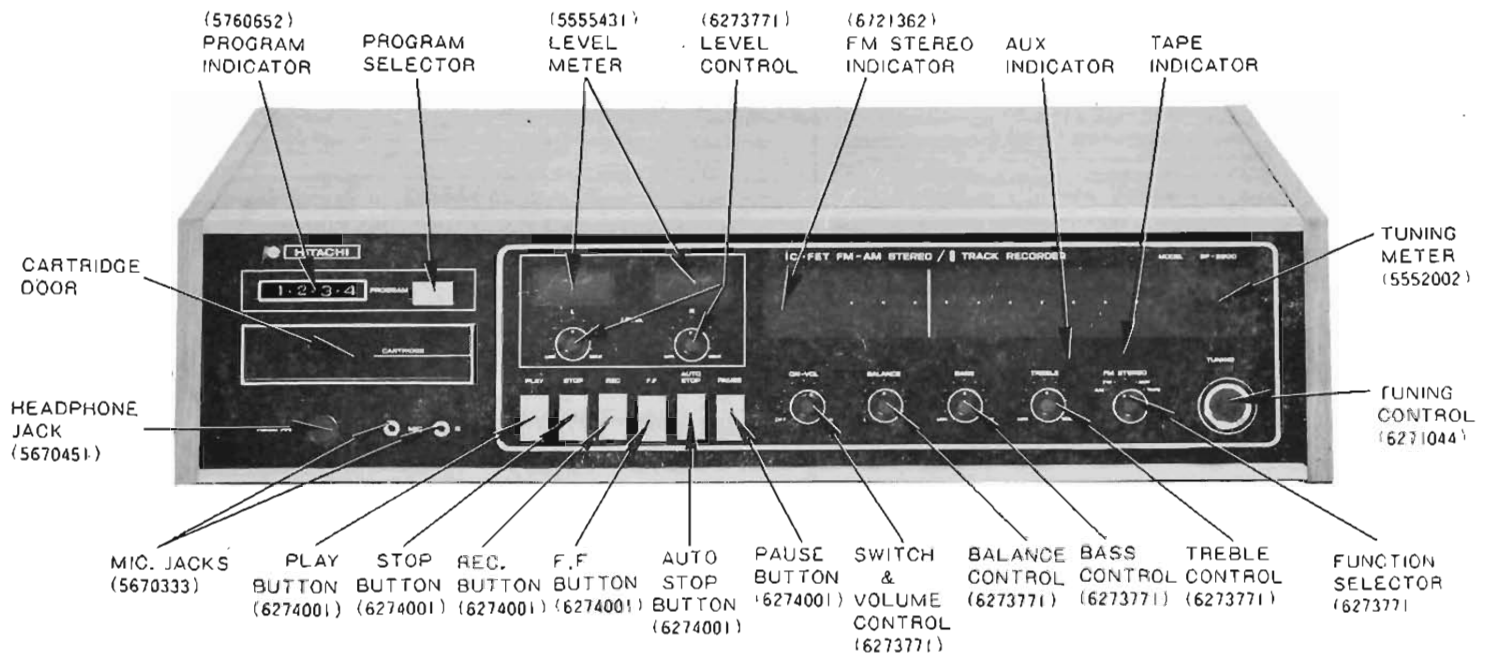

Fig. 1

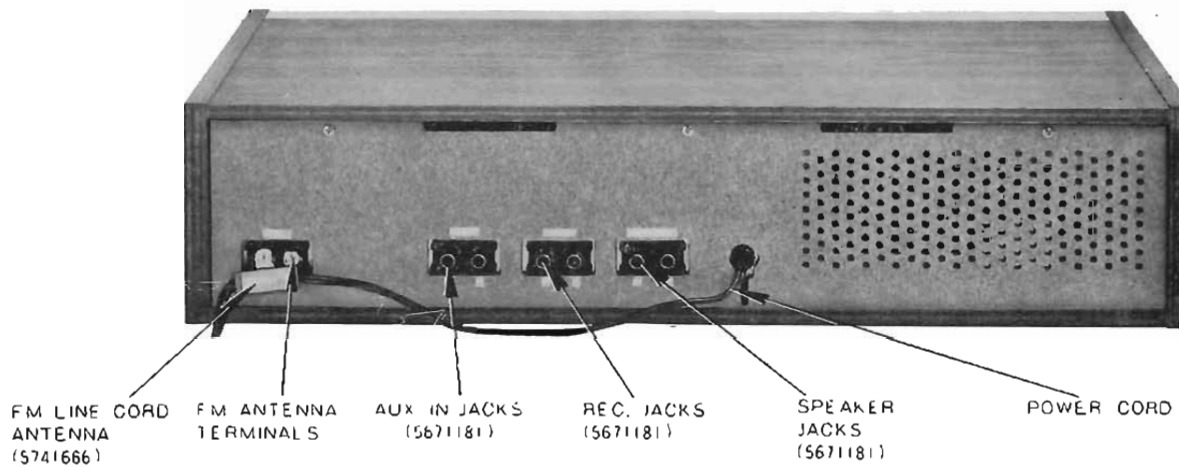
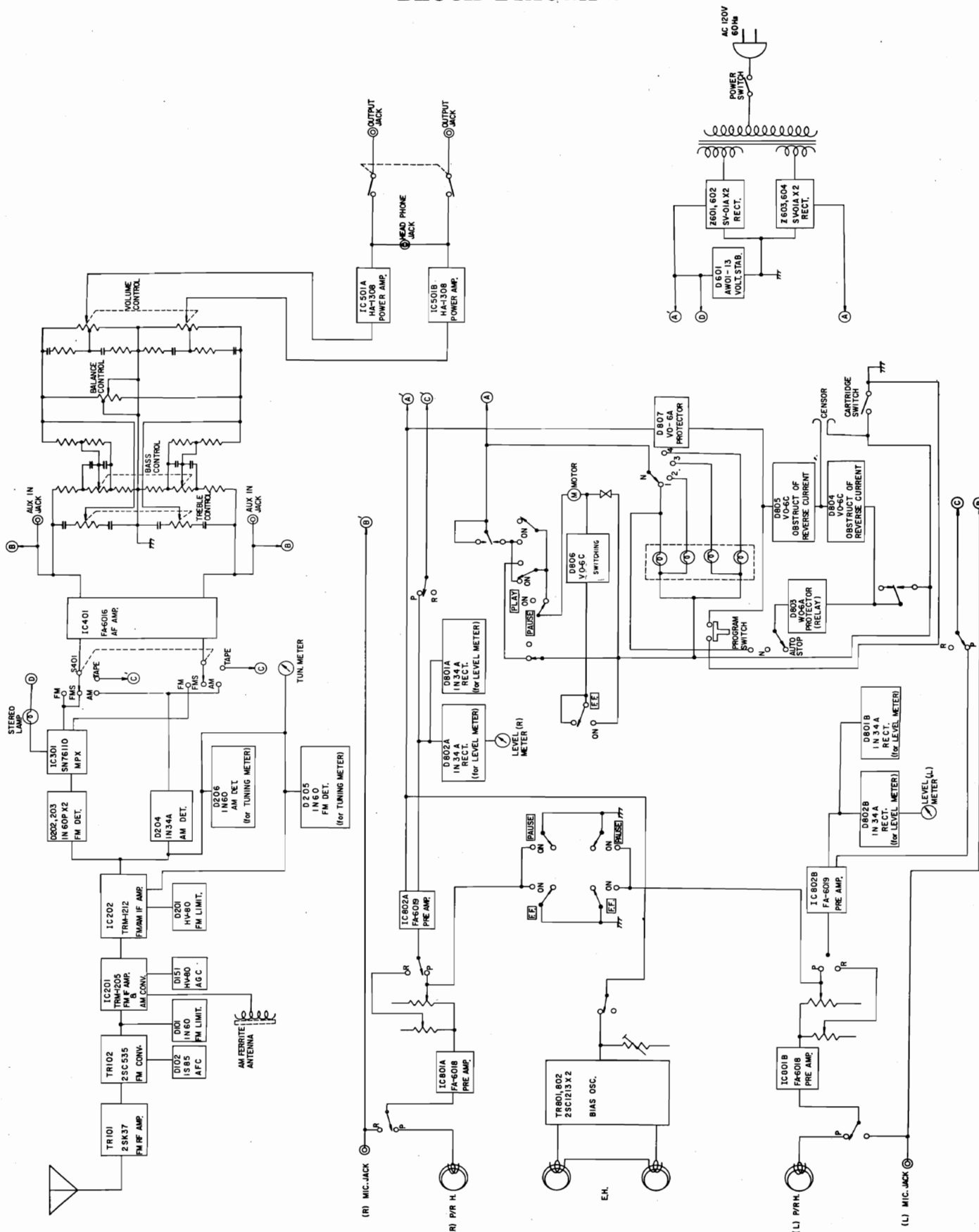

Fig. 2

BLOCK DIAGRAM



DISASSEMBLY

1. Removal of back cover

Remove one screw holding FM line cord antenna holder and remove three screws holding back cover as shown in Fig. 4.

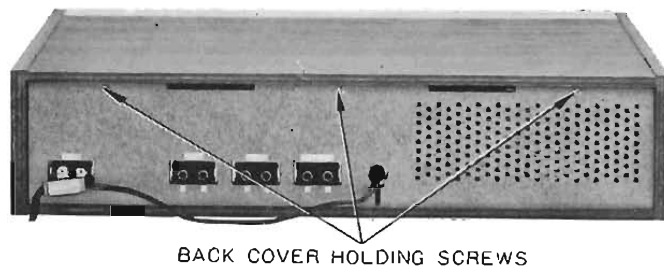

Fig. 4

2. Removal of upper case

Remove four screws holding upper case as shown in Fig. 5.

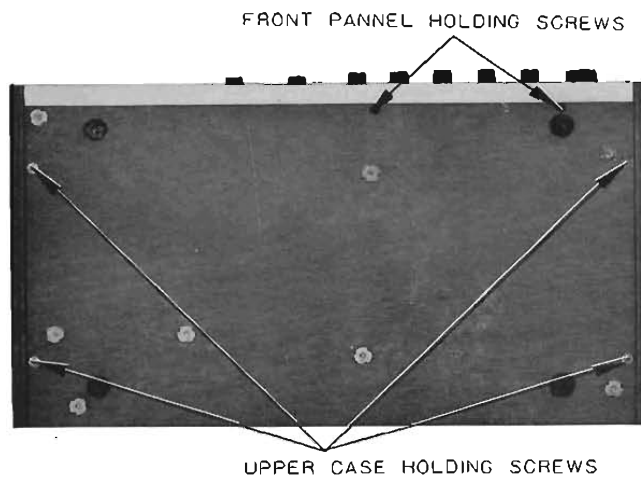

Fig. 5

3. Removal of bottom cover

Remove eight screws holding bottom cover as shown in Fig. 6.

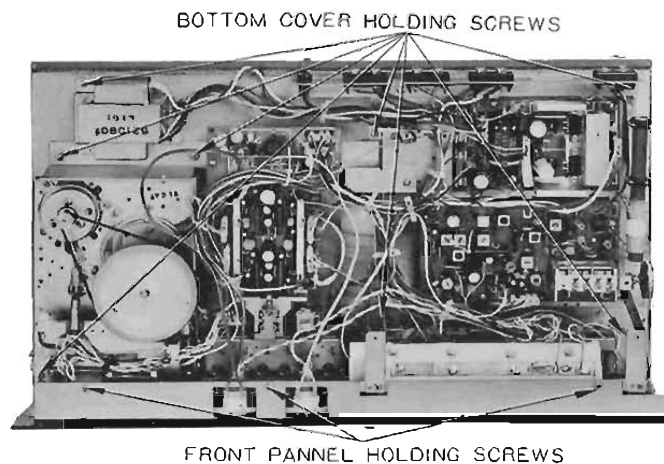

Fig. 6

4. Removal of front pannel

Remove five screws holding front pannel as shown in Figs. 5 and 6.

LUBRICATION

Lubricate those parts as shown in Figs. 7, 8, 9, 10 and 11.

Ⓜ: Machine oil

Ⓞ: Grease

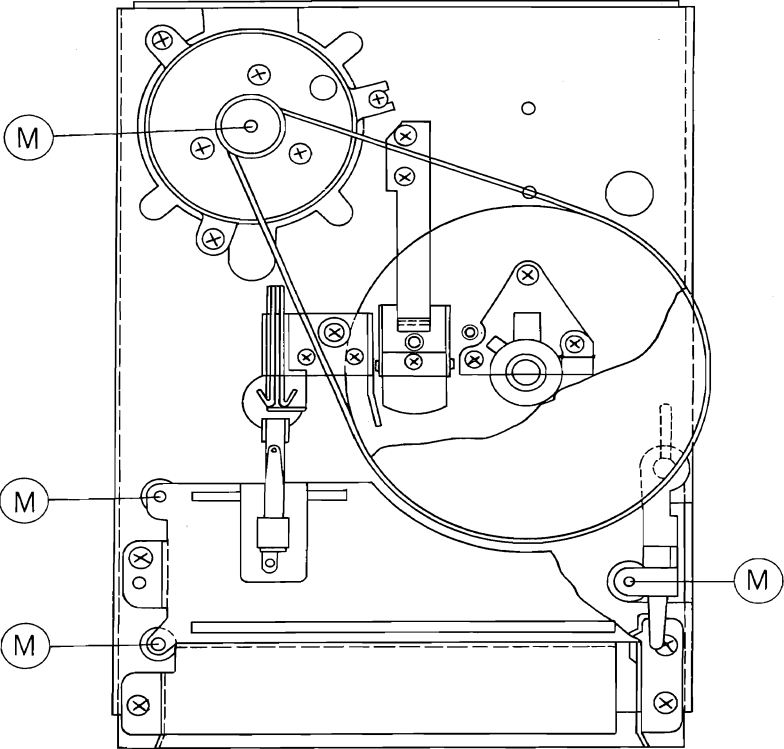

Fig. 7

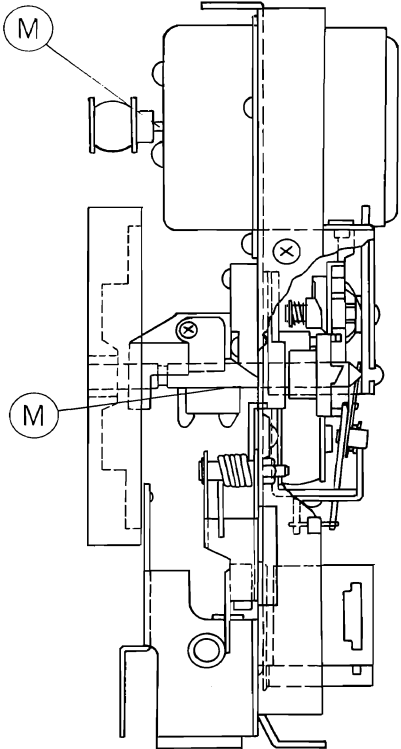

Fig. 8

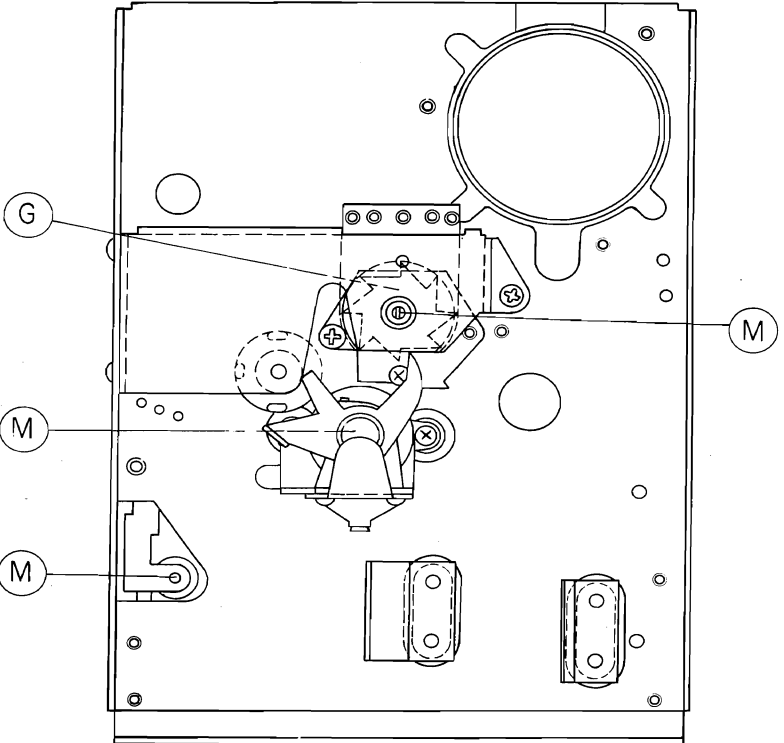

Fig. 9

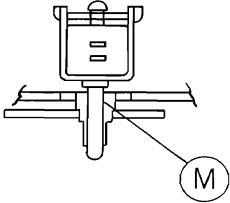

Fig. 10

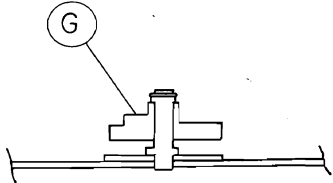

Fig. 11

DIAL CORD STRINGING

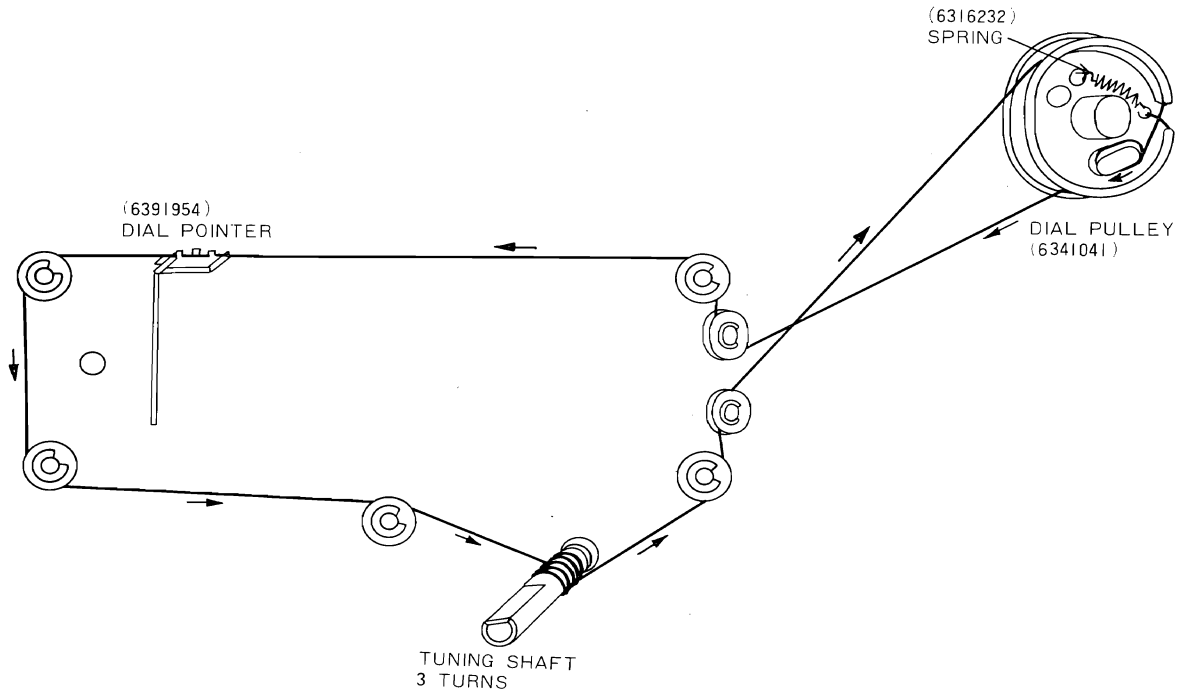

Fig. 14

INTERNAL VIEW

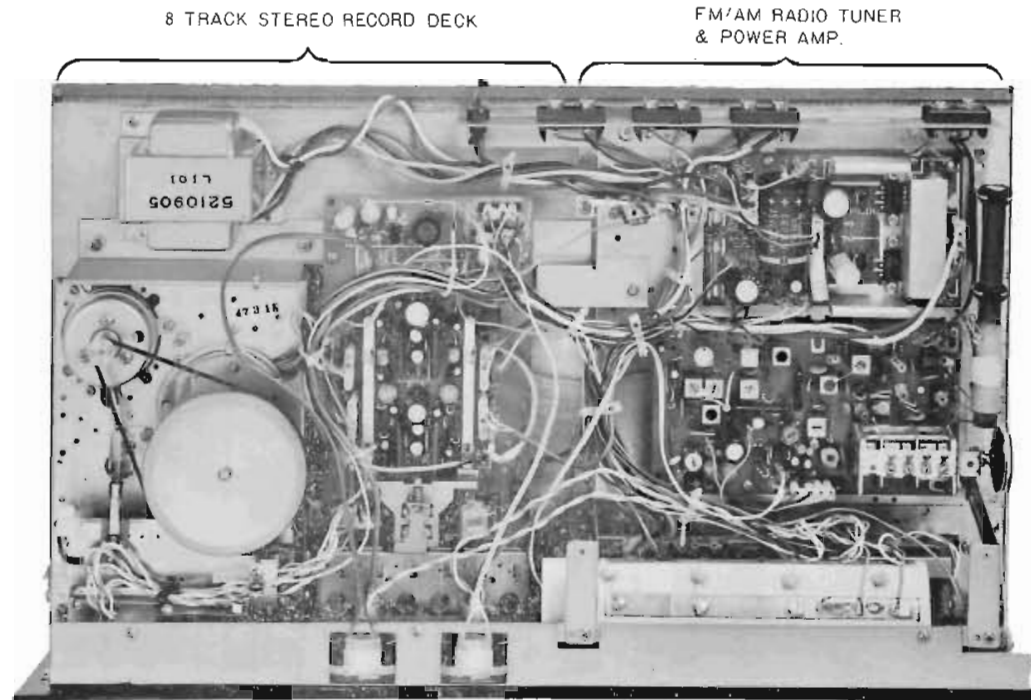

Fig. 15

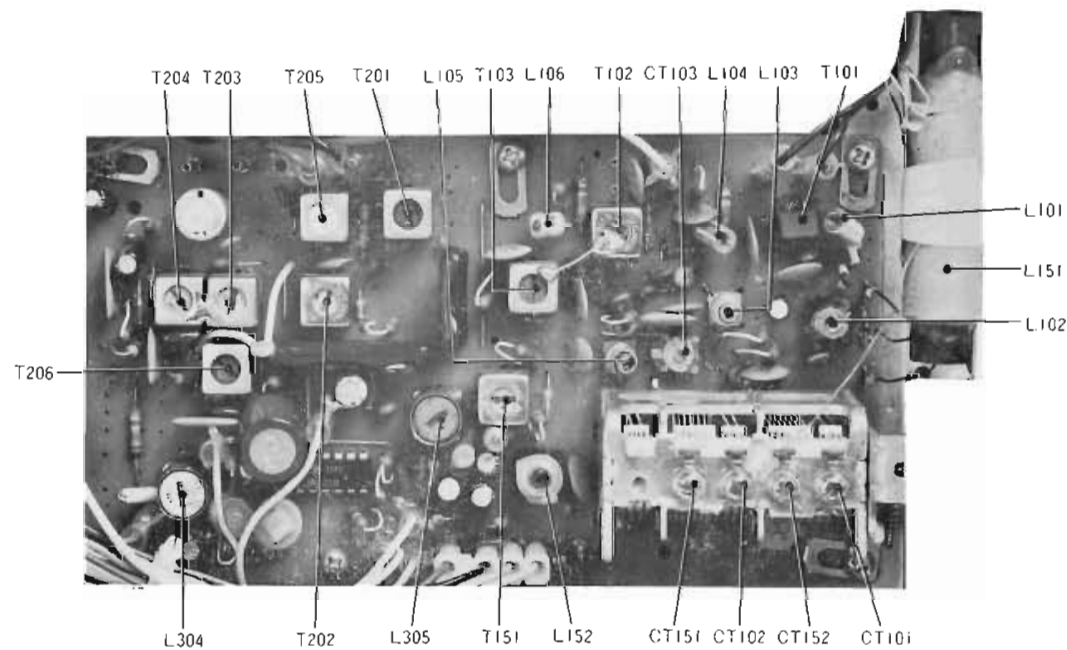
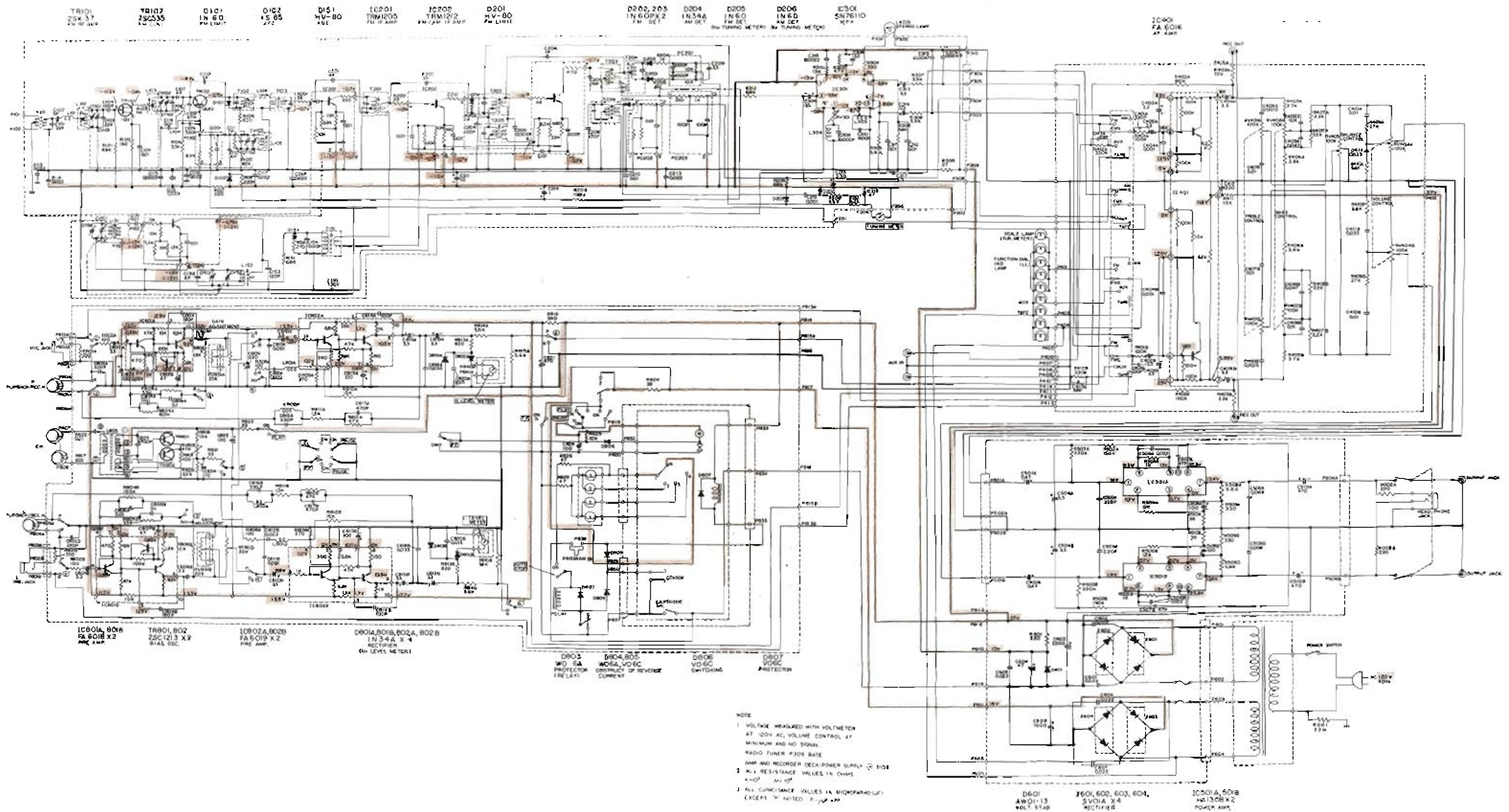

Fig. 16

REPLACEMENT PARTS

Symbol No.	Stock No.	Description	Symbol No.	Stock No.	Description
CAPACITORS:					
C 101	0248714	Ceramic, discal	C503A,B	0248732	Ceramic, discal
C 102	0248645	Ceramic, discal	C504A,B	0252613	Electrolytic
C 103	0248668	Ceramic, discal	C506A,B	0275113	Mylar
C 104	0248724	Ceramic, discal	C507A,B	0248716	Ceramic, discal
C 105	0244171	Ceramic, discal	C508A,B	0252531	Electrolytic
C 106	0248704	Ceramic, discal	C509A,B	0275116	Mylar
C 107	0248644	Ceramic, discal	C510A,B	0252535	Electrolytic
C 108	0248716	Ceramic, discal	C 601	0275113	Mylar
C 109	0248696	Ceramic, discal	C 602	0275113	Mylar
C 110	0248645	Ceramic, discal	C 603	0256099	Electrolytic
C 111	0248477	Ceramic, discal	C 604	0252525	Electrolytic
C 112	0248644	Ceramic, discal	C 605	0275113	Mylar
C 113	0275113	Mylar	C 606	0275113	Mylar
C 114	0275113	Mylar	C 607	0275113	Mylar
C 115	0274114	Mylar	C 608	0256074	Electrolytic
C 116	0275113	Mylar	C801A,B	0252613	Electrolytic
C 117	0275113	Mylar	C802A,B	0248732	Ceramic, discal
C 118	0275113	Mylar	C 803	0252531	Electrolytic
C 119	0244171	Ceramic, discal	C804A,B	0248730	Ceramic, discal
C 151	0244171	Ceramic, discal	C805A,B	0275111	Mylar
C 152	0241868	Ceramic, discal	C806A,B	0276111	Mylar
C 153	0248726	Ceramic, discal	C807A,B	0252525	Electrolytic
C 154	0221339	Styrol	C808A,B	0252613	Electrolytic
C 155	0248726	Ceramic, discal	C 809	0252632	Electrolytic
C 201	0248644	Ceramic, discal	C810A,B	0252613	Electrolytic
C 202	0248643	Ceramic, discal	C811A,B	0274111	Mylar
C 204	0248726	Ceramic, discal	C812A,B	0275113	Mylar
C 205	0274114	Mylar	C813A,B	0252331	Electrolytic
C 206	0248641	Ceramic, discal	C814A,B	0248724	Ceramic, discal
C 207	0248669	Ceramic, discal	C815A,B	0252613	Electrolytic
C 208	0248726	Ceramic, discal	C816A,B	0248736	Ceramic, discal
C 209	0252613	Electrolytic	C817A,B	0249521	Ceramic, discal
C 210	0275111	Mylar	C818A,B	0275114	Mylar
C 211	0252621	Electrolytic	C819A,B	0252613	Electrolytic
C 213	0275113	Mylar	C820A,B	0274112	Mylar
C 214	0252611	Electrolytic	C 821	0256008	Electrolytic
C 215	0252533	Electrolytic	C 822	0275111	Mylar
C 216	0248702	Ceramic, discal	C 823	0221351	Styrol
C 217	0275113	Mylar	C 824	0252621	Electrolytic
C 219	0274111	Mylar	C 825	0252631	Electrolytic
C 220	0248642	Ceramic, discal	C 826	0252631	Electrolytic
C 305	0252613	Electrolytic	CV101~152	0281583	Variable capacitor
C 308	0252613	Electrolytic	CT101~152		
C 309	0217813	Styrol	C T 103	0283113	Variable capacitor
C 310	0221339	Styrol	RESISTORS:		
C 311	0275111	Mylar	R 001	0134477	Composition
C 312	0275111	Mylar	R002A,B	0134365	Composition
C 313	0252613	Electrolytic	R 101	0170281	Carbon film
C 314	0252613	Electrolytic	R 102	0137803	Carbon film
C 315	0274115	Mylar	R 103	0137768	Carbon film
C 316	0274115	Mylar	R 104	0137857	Carbon film
C 317	0252613	Electrolytic	R 105	0137912	Carbon film
C 318	0274113	Mylar	R 106	0137812	Carbon film
C401A,B	0248736	Ceramic, discal	R 107	0137805	Carbon film
C402A,B	0252613	Electrolytic	R 108	0170295	Carbon film
C403A,B	0252613	Electrolytic	R 151		Carbon film
C404A,B	0274111	Mylar	R 152	0137806	Carbon film
C405A,B	0252613	Electrolytic	R 201	0137768	Carbon film
C406A,B	0274112	Mylar	R 202	0170215	Carbon film
C407A,B	0275111	Mylar	R 203	0137851	Carbon film
C408A,B	0275111	Mylar	R 204	0137851	Carbon film
C409A,B	0275115	Mylar	R 205	0137854	Carbon film
C410A,B	0275111	Mylar	R 206	0137951	Carbon film
C411A,B	0275114	Mylar	R 207	0137808	Carbon film
C 412	0252632	Electrolytic	R 208	0114531	Carbon film
C413A,B	0248720	Ceramic, discal	R 209	0137860	Carbon film
C501A,B	0257040	Electrolytic	R 210	0137862	Carbon film

SCHEMATIC DIAGRAM



CIRCUIT BOARD DIAGRAM

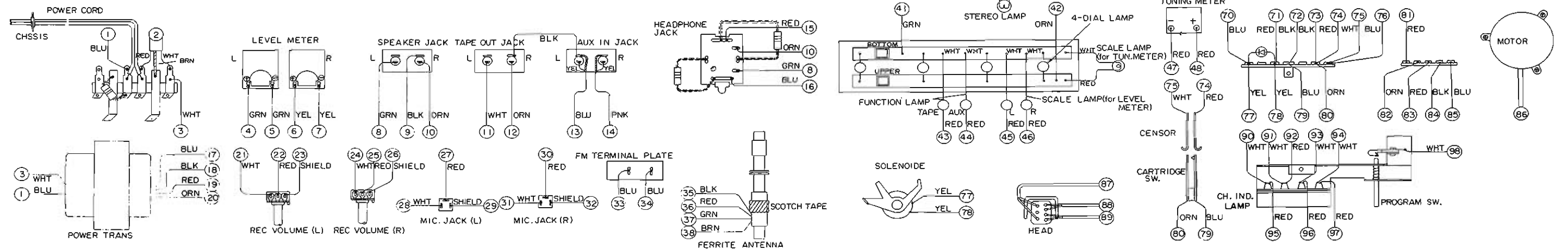
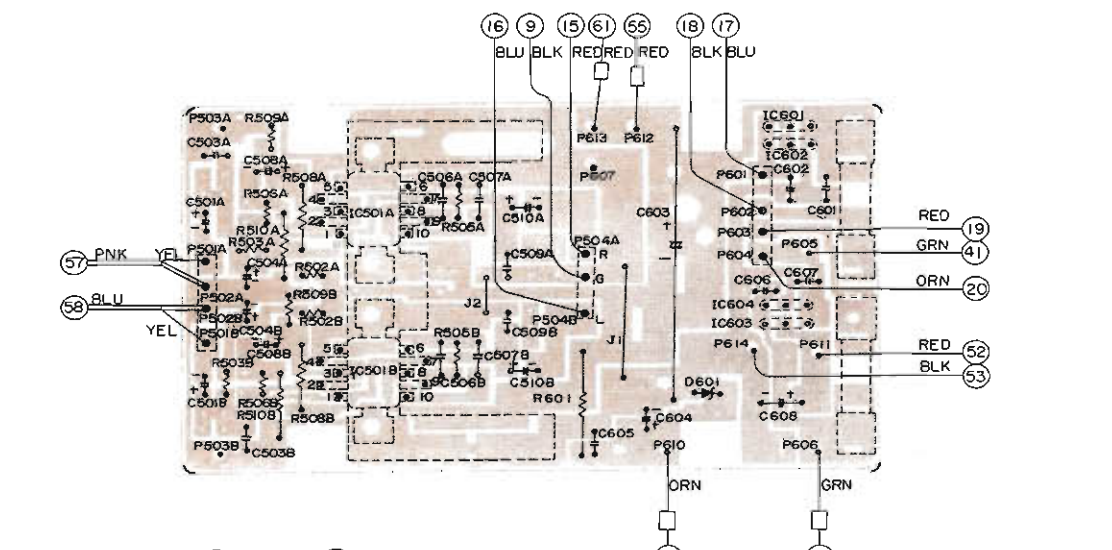
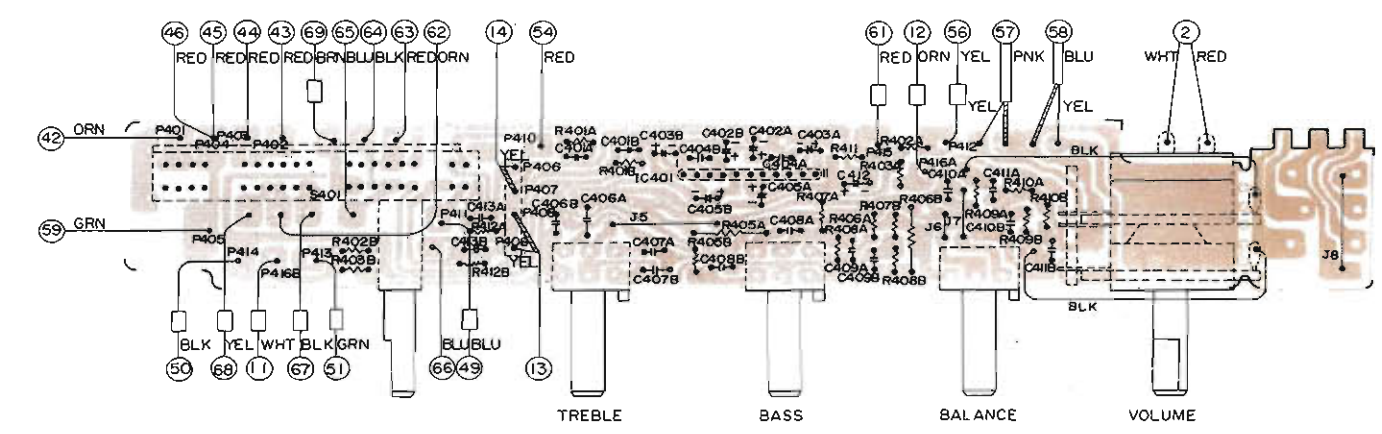
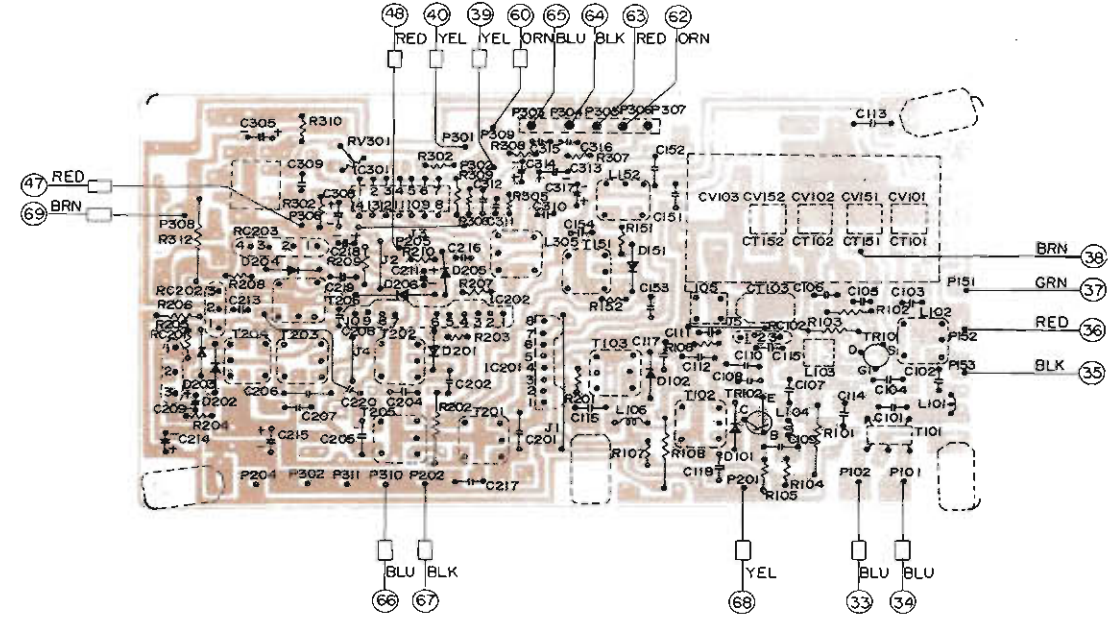
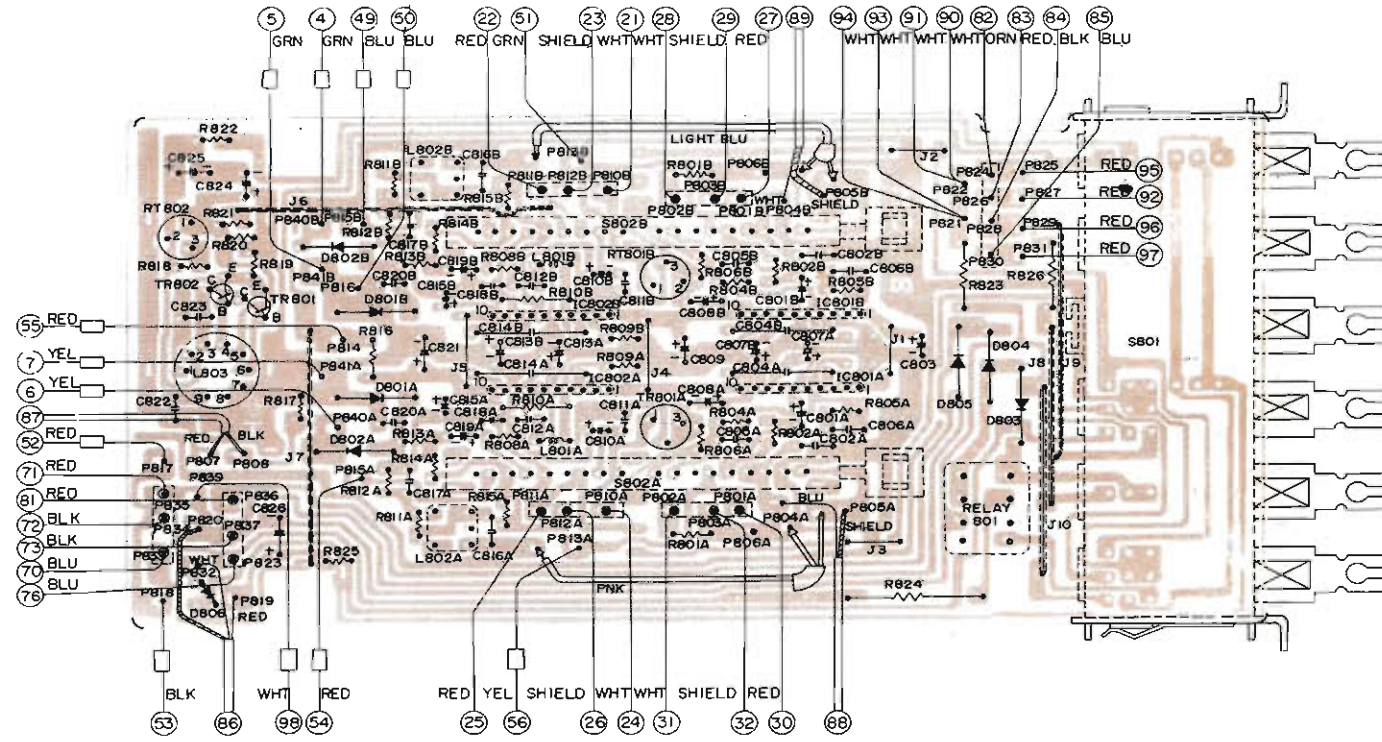

DISASSEMBLED DIAGRAM

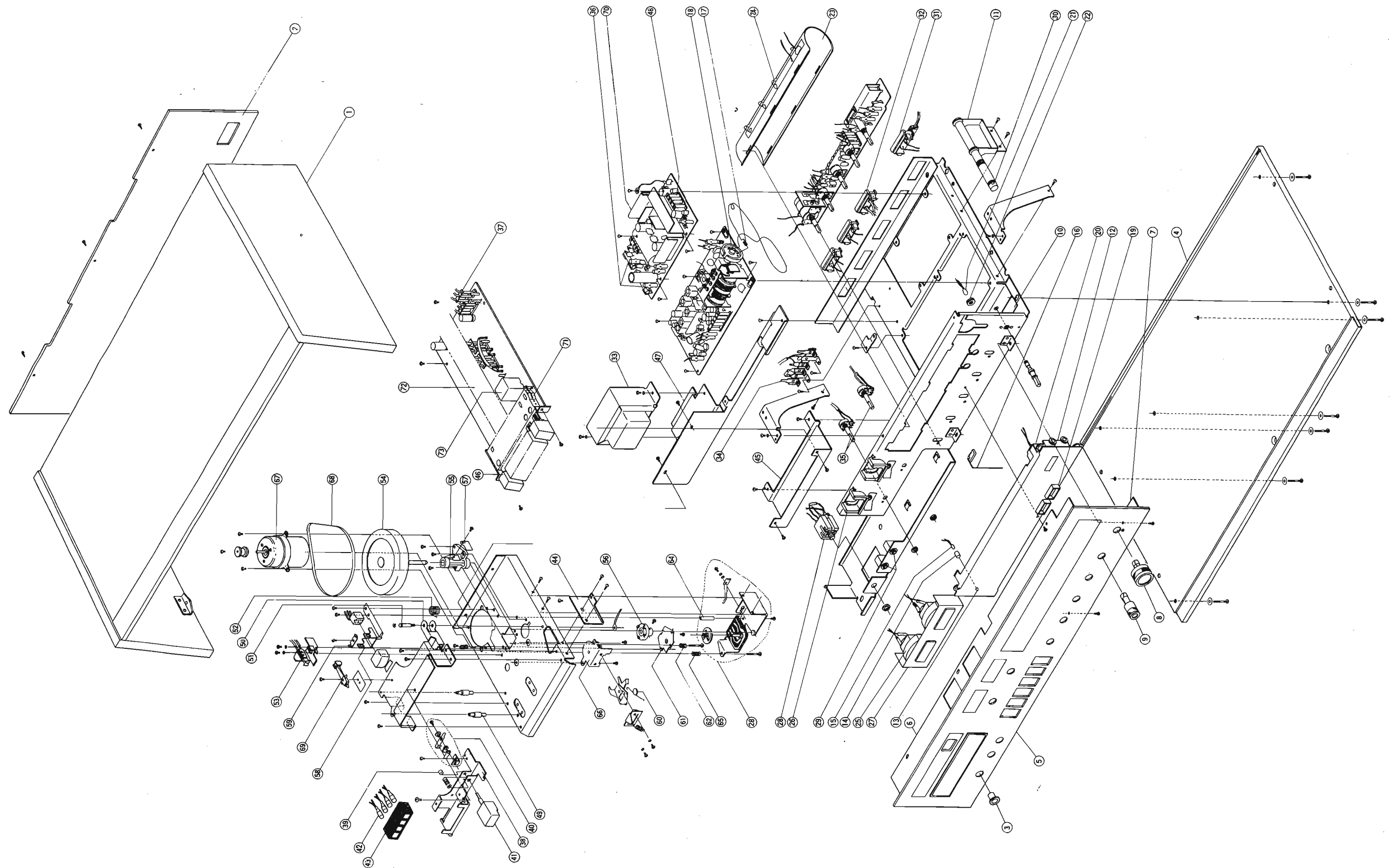

MODEL SP-2900 SERVICE MANUAL

Symbol No.	Stock No.	Description		Symbol No.	Stock No.	Description	
R 306	0137860	Carbon film	5.6kΩ ±10%	1/4SD	I C 202	5354601 IC	
R 307	0114467	Carbon film	3.3kΩ ±10%	1/4P	I C 301	5351042 IC	
R 308	0114467	Carbon film	3.3kΩ ±10%	1/4P	I C 401	5353091 IC	
R 309	0137764	Carbon film	27Ω ±10%	1/4SD	IC501A,B	5350132 IC	
R 310	0137853	Carbon film	1.5kΩ ±10%	1/4SD	Z 601	5330371	
R 312	0114471	Carbon film	6.8kΩ ±10%	1/4P	Z 602	5330372	
R401A,B	0137951	Carbon film	100kΩ ±10%	1/4SD	Z 603	5330371	
R402A,B	0137954	Carbon film	180kΩ ±10%	1/4SD	Z 604	5330372	
R403A,B	0137905	Carbon film	22kΩ ±10%	1/4SD	IC801A,B	5353111 IC	
R405A	0170276	Carbon film	27kΩ ±10%	1/4F	IC802A,B	5353121 IC	
R405B	0137906	Carbon film	27kΩ ±10%	1/4SD	D 101	0575005 Diode	
R406A	0137858	Carbon film	3.9kΩ ±10%	1/4SD	D 102	0575024 Diode	
R406B	0170258	Carbon film	3.9kΩ ±10%	1/4F	D 151	5330261 Varistor	
R407A,B	0137855	Carbon film	2.2kΩ ±10%	1/4SD	D 201	5330261 Varistor	
R408A,B	0137905	Carbon film	22kΩ ±10%	1/4SD	D 202	0575019 Diode	
R409A,B	0137906	Carbon film	27kΩ ±10%	1/4SD	D 203	0575019 Diode	
R410A,B	0137860	Carbon film	5.6kΩ ±10%	1/4SD	D 204	0575001 Diode	
R 411	0137853	Carbon film	1.5kΩ ±10%	1/4SD	D 205	0575005 Diode	
R412A,B		Carbon film	330kΩ ±10%	1/4SD	D 206	0575005 Diode	
R502A,B	0137953	Carbon film	150kΩ ±10%	1/4SD	D 601	5330054 Zener AW01-13	
R503A,B	0137955	Carbon film	220kΩ ±10%	1/4SD	D801A,B	0575001 Diode	
R505A,B	0137851	Carbon film	1kΩ ±10%	1/4SD	D802A,B	0575001 Diode	
R506A,B	0137902	Carbon film	12kΩ ±10%	1/4SD	D 803	5330341 Diode	
R508A,B	0170260	Carbon film	5.6kΩ ±10%	1/4F	D 804	5330341 Diode	
R509A,B	0137807	Carbon film	330Ω ±10%	1/4SD	D 805	5330101 Diode	
R510A,B	0170218	Carbon film	39Ω ±10%	1/4F	D 806	5330101 Diode	
R 601	0171209	Metal oxide	220Ω ±10%	2FB	D 807	5330101 Diode	
R801A,B	0137807	Carbon film	330Ω ±10%	1/4SD	TRANSFORMERS:		
R802A,B	0137801	Carbon film	100Ω ±10%	1/4SD	T 101	0318543 FM antenna	
R804A,B	0137953	Carbon film	150kΩ ±10%	1/4SD	T 102	0322236 FM IFT	10K:0.3K
R805A,B	0137907	Carbon film	33kΩ ±10%	1/4SD	T 103	5142007 FM IFT	6.8K:0.56K
R806A,B	0137902	Carbon film	12kΩ ±10%	1/4SD	T 151	5132002 AM IFT	
R808A,B	0137801	Carbon film	100Ω ±10%	1/4SD	T 201	0322203 FM IFT	
R809A,B	0137806	Carbon film	270Ω ±10%	1/4SD	T 202	0329602 FM IFT	
R810A,B	0170273	Carbon film	15kΩ ±10%	1/4F	T 203	0326026 FM discriminator	
R811A,B	0137853	Carbon film	1.5kΩ ±10%	1/4SD	T 204	0326028 FM discriminator	
R812A,B	0137909	Carbon film	47kΩ ±10%	1/4SD	T 205	0322113 AM IFT	30K:0.5K
R813A,B	0137812	Carbon film	820Ω ±10%	1/4SD	T 206	0322120 AM IFT	10K:5K
R814A,B	0137860	Carbon film	5.6kΩ ±10%	1/4SD	COILS:		
R815A,B	0137860	Carbon film	5.6kΩ ±10%	1/4SD	L 101	5123271 FM trap	0.5μH
R 816	0137808	Carbon film	390Ω ±10%	1/4SD	L 102	5123119 FM RF	
R 817	0137801	Carbon film	100Ω ±10%	1/4SD	L 103	5126006 FM RF	
R 818	0137903	Carbon film	15kΩ ±10%	1/4SD	L 104	5123271 FM trap	0.5μH
R 819	0137801	Carbon film	100Ω ±10%	1/4SD	L 105	0318041 FM oscillator	
R 820	0137857	Carbon film	3.3kΩ ±10%	1/4SD	L 106	5152021 Choke	6.8μH
R 821	0137765	Carbon film	33Ω ±10%	1/4SD	L 151	5112552 Ferrite antenna	
R 822	0137763	Carbon film	22Ω ±10%	1/4SD	L 152	5120174 AM oscillator	
R 823	0134297	Composition	47Ω ±10%	1/2GF	L 304	5120183 19kHz tuner	
R 824	0190158	Wire wound	39Ω ±5%	2P	L 305	5120189 38kHz tuner	
R 825	0137901	Carbon film	5.6kΩ ±10%	1/4SD	L801A,B	0333151 Choke	
R 826	0134297	Composition	47Ω ±10%	1/2GF	L802A,B	5120303 SCA trap	
P C 102	0186415	CR pack	82kΩ, 0.001μF		L 803	5260025 Oscillator	
P C 201	0186385	CR pack	10kΩ × 2, 0.001μF × 2		for Final assembly		
P C 202	0186386	CR pack	1kΩ × 1, 100pF × 2		①	6127621 Wood cabinet	
P C 203	0186514	CR pack			②	6190921 Back cover	
R V 301	0151882	Semi variable	470Ω		8788412	Tapping screw-3mm ∅ × 10mm (3 req'd) for back cover mounting	
RV401A,B	0151444	Variable	100kΩ (A)		7780147	Pan head screw with washer-4mm ∅ × 18mm (4 req'd) for bottom cabinet mounting	
RV402A,B	0151445	Variable	100kΩ (B)		③	6721371 Headphone cap for headphone jack	
R V 403	0151447	Variable	100kΩ (Z)		7197661	Cord holder } for FM line cord antenna	
RV404A,B	0156941	Variable	100kΩ (A)		0043791	Cord cover }	
RV801A,B	0151887	Variable	22kΩ (B)				
R V 802	0151888	Variable	47kΩ (B)				
SEMI-CONDUCTORS:							
T R 101	5320702	Transistor	2SK37				
T R 102	0573511	Transistor	2SC535C	Si 100MHz 200mW			
T R 801	5320612	Transistor	2SC1213B				
T R 802	5320612	Transistor	2SC1213B				
I C 201	5354541	IC	TRM1205				

MODEL SP-2900 SERVICE MANUAL

Symbol No.	Stock No.	Description	Symbol No.	Stock No.	Description
		for Cabinet assembly			
④	6152001	Bottom cabinet	③④	5680823	4P terminal plate
	8711610	Pan head screw-4mm ϕ ×10mm		8781436	Tapping screw-3mm ϕ ×6mm (2 req'd) for 4P terminal plate mounting
	8811116	Washer-4mm ϕ (7 req'd) for bottom cabinet mounting	③⑤	0151446	Level volume (20k Ω B)
⑤	6217031	Smoke plate assembly	③⑥	0591138	Fuse (2A)
⑥	7246242	Pannel bracket (A)	③⑦	5651545	3P Socket
				5651543	3P Socket
				5651546	3P Socket
⑦	7246254	Pannel bracket (B)		5651542	3P Socket
	8781436	Tapping screw-3mm ϕ ×6mm		5650774	3P Socket for between AF P.C.B and headphone jack
	8711406	Pan head screw-3mm ϕ ×6mm		5650347	4P Socket for between TONE P.C.B and AUX jack
⑧	6271044	Knob (TUNING)			for 8 deck assembly
⑨	6273771	Knob (FUNCTION, TREBLE, BASS, BALANCE, VOLUME, LEVEL (R) & LEVEL (L))	8781436	8781436	Tapping screw-3mm ϕ ×6mm (2 req'd) for TONE P.C.B mounting
	6310162	Spring washer (8 req'd) for knob mounting	8711406	8711406	Pan head screw-3mm ϕ ×6mm (2 req'd) for TONE P.C.B mounting (2 req'd) for 8 deck assembly mounting
		for Chassis assembly	③⑧	7253401	SL bracket assembly
	8711406	Pan head screw-3mm ϕ ×6mm (2 req'd) for power transformer mounting	③⑨	7667381	Rubber cap
	8781436	Tapping screw-3mm ϕ ×6mm for tap bracket mounting	④⑩	5632131	Push switch
⑩	7716788	Insulating plate for chassis		8781436	Tapping screw-3mm ϕ ×6mm for push switch mounting
	8781436	Tapping screw-3mm ϕ ×6mm (4 req'd) for HF-2 P.C.B mounting (4 req'd) for AF P.C.B mounting	④①	6273991	Button (A)
⑪	7232481	Antenna supporter		8711404	Pan head screw-3mm ϕ ×4mm for SL bracket assembly mounting
	8781436	Tapping screw-3mm ϕ ×6mm (2 req'd) for antenna supporter mounting	④②	5760652	Lamp (4 req'd) for channel indicator illumination
⑫	6462611	Scale plate assembly	④③	7669011	Lamp holder for lamp
	8745406	Bind screw-3mm ϕ ×6mm for scale plate mounting	④④	7251541	Deck bracket
⑬	6721362	Indicator		8781436	Tapping screw-3mm ϕ ×6mm (2 req'd) for deck bracket mounting
⑭	7662641	Rubber plate for lamp (stereo)	④⑤	7250371	RC bracket
⑮	5760345	Lamp for stereo	④⑥	6274001	Button (B) (PLAY, STOP, REC, F.F, AUTO STOP and PAUSE)
⑯	6391954	Pointer	④⑦	7123701	TAP bracket assembly
⑰	6316232	Spring for pulley		5650771	3P socket
⑱	6341041	Pulley	④⑧	5650781	4P socket
⑲	7668801	Lamp holder			for Speaker box assembly
⑳	5552002	Tuning meter	6152431	6152431	Speaker box
㉑	5760652	Lamp	0256501	0256501	Electrolytic capacitor (2 req'd) for speaker
㉒	0971002	Rubber cushion for lamp	5411171	5411171	Speaker-16cm
㉓	7721871	Reflector plate	5411491	5411491	Speaker-5cm
㉔	5760411	Pilot lamp (4 req'd) for dial scale illumination	7772452	7772452	Nut (12 req'd) for speaker mounting
㉕	5555431	Level meter	6191053	6191053	Back plate
㉖	7669091	Meter holder (2 req'd) for level meter	8788414	8788414	Tapping screw-3mm ϕ ×14mm (20 req'd) for back plate mounting
㉗	7736841	Spacer for level meter	5742811	5742811	Speaker cord for front
㉘	5670451	Headphone jack			for 8 deck assembly
㉙	5670333	Mould jack for microphone	④⑨	6725051	Pack roller
	0948771	Insulating washer		8641406	Bind screw-3mm ϕ ×6mm (2 req'd) for pack cover mounting
	7710992	Washer for mould jack mounting	⑤⑩	7263491	Pressure roller assembly
③⑩	0638351	Wedge for ferrite antenna	⑤①	7534341	Arm shaft
③①	5680682	FM terminal plate	⑤②	6323911	Spring
③②	5671181	2 pin jack (L)		7230902	"E" ring-3mm ϕ for roller arm mounting
③③	5210908	Power transformer		8821114	Nut-3mm ϕ
	8711606	Pan head screw-4mm ϕ ×6mm	8813124	8813124	Spring washer-3mm ϕ for roller arm shaft mounting
	8813126	Spring washer-4mm (2 req'd) for power transformer mounting	⑤③	7123061	Tape guide
	5741666	Power cord	0711304	0711304	Pan head screw-2.6mm ϕ ×4mm
	6703751	Bushing for power cord	8813123	8813123	Spring washer-2.6mm ϕ (2 req'd) for tape guide assembly mounting
			⑤④	6371081	Flywheel capstan

MODEL SP-2900 SERVICE MANUAL

Symbol No.	Stock No.	Description	Symbol No.	Stock No.	Description
55	6971241 8641410	Flywheel metal Bind screw-3mm ϕ \times 10mm (2req'd) for flywheel metal mounting		5890001	Head connector
56	6728411	Channel selector cam	69	5603001	Leaf switch
57	7250881	Take up prevention plate		8715105	Pan head screw-2mm ϕ \times 5mm for leaf switch mounting
	0711304	Pan head screw-2.6mm ϕ \times 4mm for take up prevention plate mounting		8641406	Bind screw-3mm ϕ \times 6mm for staple mounting
	8711405	Pan head screw-3mm ϕ \times 5mm (2 req'd) for channel selector cam mounting	for P.C.B. assembly		
	8813123	Spring washer-2.6mm ϕ for take up prevention plate mounting	P101,102 P201~206 P301,302 P308~311	0542109	GT pin
	7779711	Washer for between 8 cam and flywheel metal mounting	P303~306	5660623	5P plug
58	7263451	Head holder assembly	S 401	5610571	Rotary switch
59	7250891	Head holder (2)	P410~415, 416A,B	0542109	GT pin
60	7263461	Lever spring	P406~409	5660622	4P plug
	8641406	Bind screw-3mm ϕ \times 6mm (2 req'd) for lever spring mounting		5651259	Amp in socket for between TONE P.C.B and HF P.C.B
61	7263371	Head base assembly		5651278	Amp in socket for between TONE P.C.B and AF P.C.B
62	6326071	Spring (2 req'd) for head base high adjustment		5760651	Lamp for level meter illumination (left)
	8711416	Pan head screw-3mm ϕ \times 16mm for head base mounting		5760652	Lamp for level meter illumination (right)
	8711410	Pan head screw-3mm ϕ \times 10mm (2 req'd) for head base high adjustment			
63	6728421	8 cam assembly	70	7255651	Radiator plate
64	7532111	Mounting plate stud		7777257	Tapping screw-3mm ϕ \times 8mm (4req'd) for radiator plate mounting
	0711306	Pan head screw-2.6mm ϕ \times 6mm		5720221	Fuse holder
	8813123	Spring washer-2.6mm ϕ for mounting plate stud mounting	P503A,B P605~608 P610~614	0542109	Plug
65	6323931	Spring	P504A,B	5660621	3P plug
	8711420	Pan head screw-3mm ϕ \times 20mm for cam mounting plate mounting	P501A,B P501A,B	5660622	4P plug
	0711312	Pan head screw-2.6mm ϕ \times 13mm	P601~604	5660626	4P plug
	8813123	Spring washer-2.6mm ϕ for mounting plate stud mounting	71 S 801	5632591	Push switch
	8641406	Bind screw-3mm ϕ \times 6mm (2 req'd) for cam mounting plate assembly mounting	72 S802A,B	5620602	Slide switch
66	5642001	Solenoid assembly	73 RELAY801	5640412	Relay
	8711404	Pan head screw-3mm ϕ \times 4mm		5660621	3P plug
	8813124	Spring washer-3mm ϕ (2 req'd) for solenoid assembly mounting		5660622	4P plug
67	5571321	DC motor		7124411	Switch bracket assembly for (S801) and (S802A,B)
	8641410	Bind screw-3mm ϕ \times 10mm (3 req'd) for DC motor mounting			
68	6351011	Motor belt			
	5680901	6P terminal plate			
	8641406	Bind screw-3mm ϕ \times 6mm for 6P terminal plate mounting			
	5330101	Rectifier VO-6C			
	5650771	3P socket $\ell = 250$			
	5650781	4P socket $\ell = 250$			



Head Office : 5, 1-chome, Marunouchi, Chiyoda-ku, Tokyo
Tel. Tokyo (212) 1111 (80 lines)
Cable Address : "HITACHY" TOKYO
Codes : All Codes Used

Printed in Japan
Aug. '72 (K)