



**FM/AM COMPACT STEREO
with
8 TRACK STEREO RECORDER
MODEL SP-2960
SERVICE MANUAL**

No. 711

1974

SPECIFICATIONS

RADIO CIRCUIT SYSTEM.....FM/AM superheterodyne	SENSITIVITY (Usable)FM : $7\mu\text{V}$ (30 dB S/N)
TUNING RANGE.....FM : 88~108 MHz	AM : $250\mu\text{V/m}$ (20 dB S/N)
AM : 530~1,605 kHz	ANTENNAFM : Line cord antenna or
IC.....15	external antenna terminal
TRANSISTOR7	AM : Built-in ferrite-core antenna
FET1	TERMINALS.....Microphone jacks : MICROPHONES
DIODE29	L/MONO, R 220 Ω
CARTRIDGE.....8-track 2-channel / 4-channel	Headphone jack : PHONES 8 Ω
TAPE SPEED3-3/4 ips (9.5cm/sec)	Speaker jacks : SPKR 8 Ω
RECORDING SYSTEMAC bias	Auxiliary in jacks : AUX. IN 350 k Ω
ERASE SYSTEMAC erase	Recording output jacks : REC. OUT
PLAYING SYSTEM2/4 Channel	30 k Ω
TAPE CHANGE SYSTEM.....Automatic or push button system	DIMENSIONS5-1/2" (H) \times 22-1/16" (W) \times
AUDIO OUTPUT40 W (P.M.P.) Total	12-15/16" (D)
FREQUENCY RANGE.....50 ~ 15,000 Hz	(13.9 \times 56.0 \times 32.9cm)
POWER SUPPLYAC : 120V, 60 Hz	WEIGHT21 lbs
POWER CONSUMPTION80 W	

CONTROLS

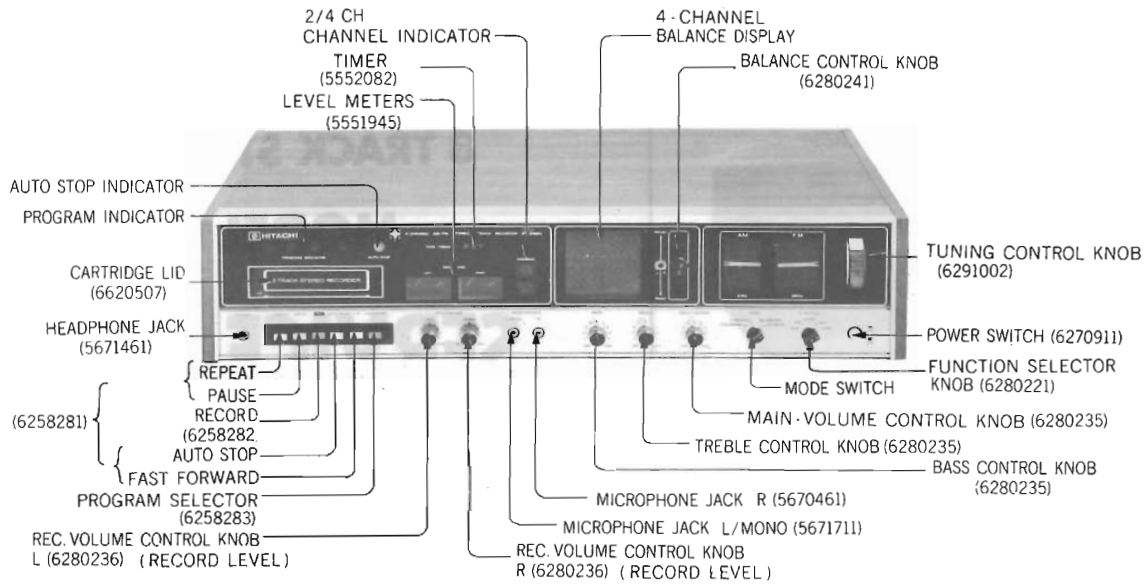

Fig. 1

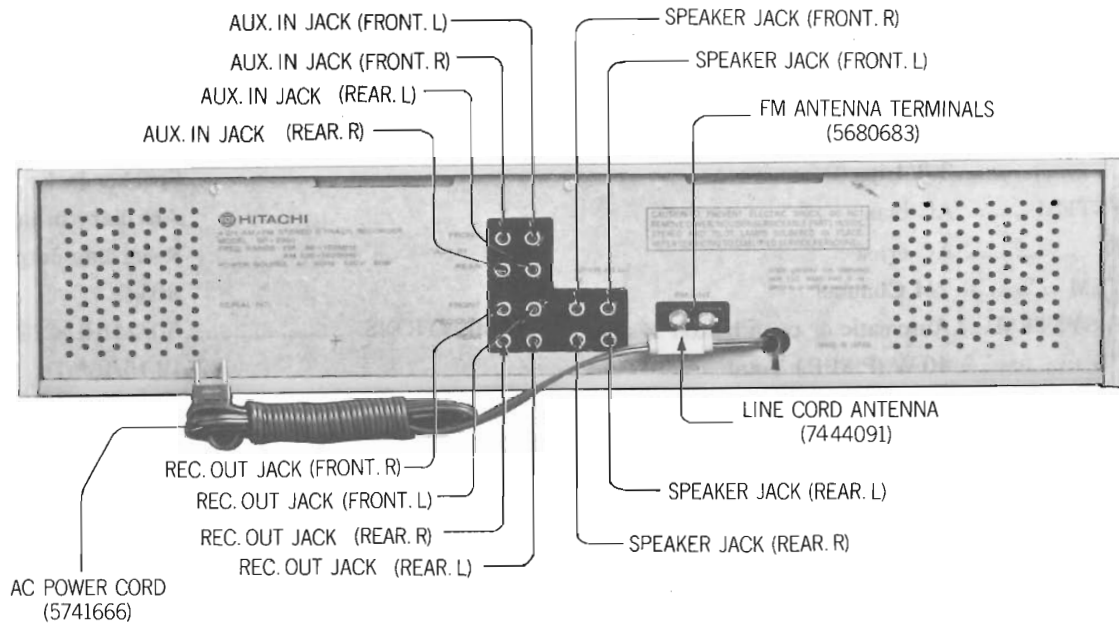

Fig. 2

BLOCK DIAGRAM

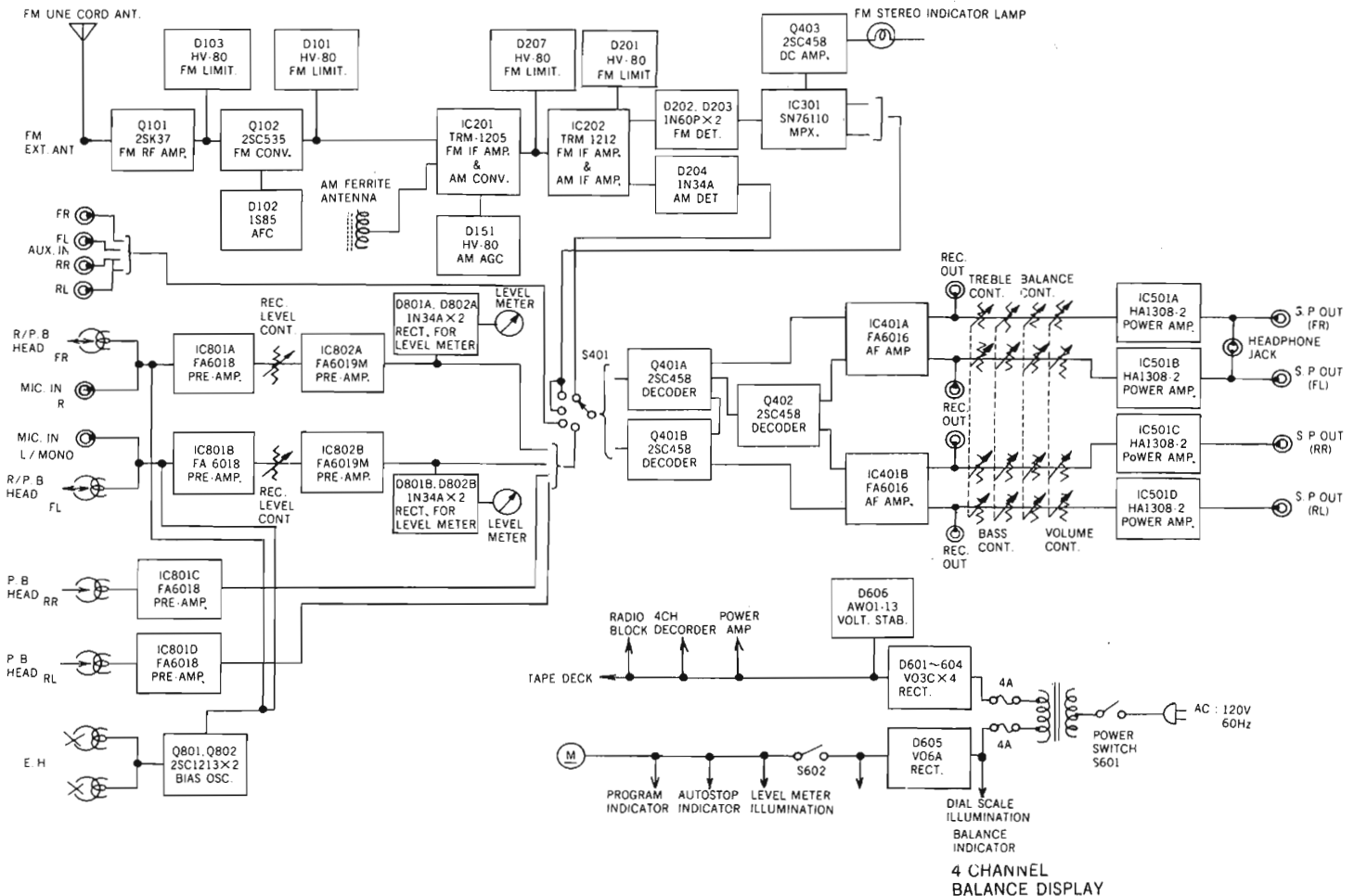

Fig. 3

DISASSEMBLY

1. Removal of rear cover

Remove loosely one screw holding FM line cord antenna.
Remove three screws holding rear cover as shown in Fig. 4.

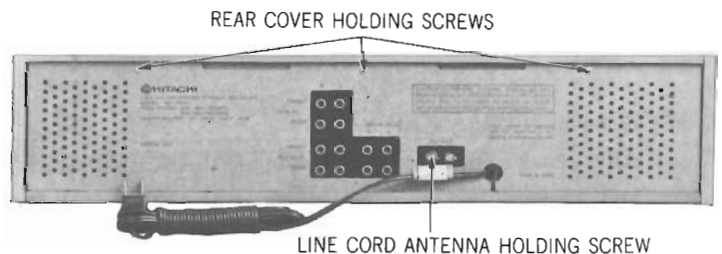

Fig. 4

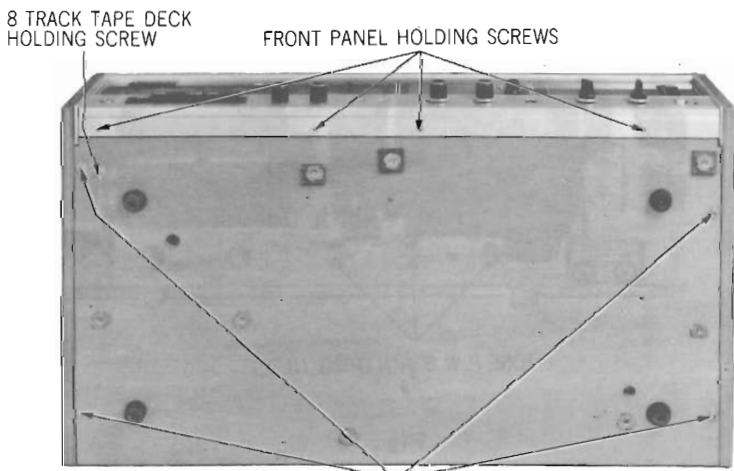

Fig. 5

2. Removal of cabinet.

Remove four screws holding cabinet as shown in Fig. 5.

3. Removal of front panel

After pulling out eight knobs and remove eight screws holding front panel as shown in Figs, 5 and 6.

4. Removal of 8 track tape deck

Remove four screws holding 8 track tape deck as shown in Figs, 5 and 6.

5. Removal of chassis

Remove five screws holding chassis as shown in Fig. 6.

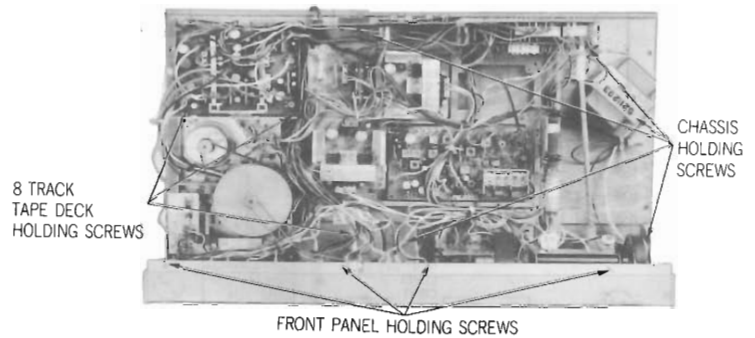

Fig. 6

6. Removal of printed circuit board

1). Removal of RF/IF P. W. B

Remove five screws holding RF/IF P. W. B as shown in Fig. 7.

2). Removal of AF P. W. B

Remove seven screws holding AF P. W. B as shown in Fig. 7.

3). Removal of S. Q P. W. B

Remove one screw holding S. Q P. W. B as shown in Fig. 7.

4). Removal of JACK P. W. B

Remove three screws holding JACK P. W. B as shown in Fig. 7.

AF P. W. B HOLDING SCREWS JACK P. W. B HOLDING SCREWS

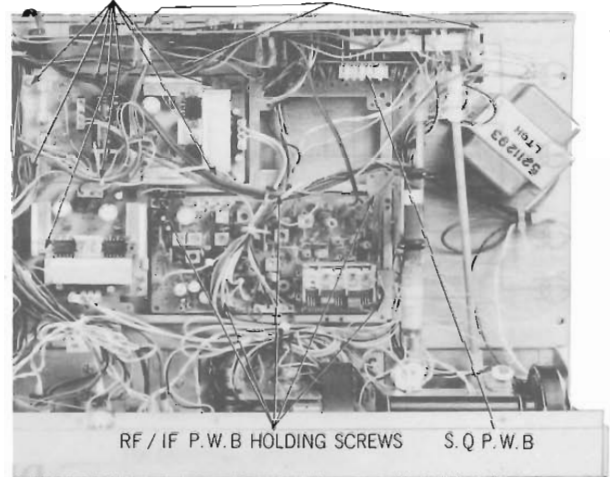

Fig. 7

5). Removal of BALANCER P. W. B

After remove out two screws holding BALANCER DISPLAY, and remove two screws holding BALANCER P. W. B as shown in Fig. 8.

6). Removal of TONE P. W. B

Remove three nuts holding TONE P. W. B as shown in Fig. 8.

BALANCE DISPLAY HOLDING SCREWS BALANCER P. W. B HOLDING SCREWS

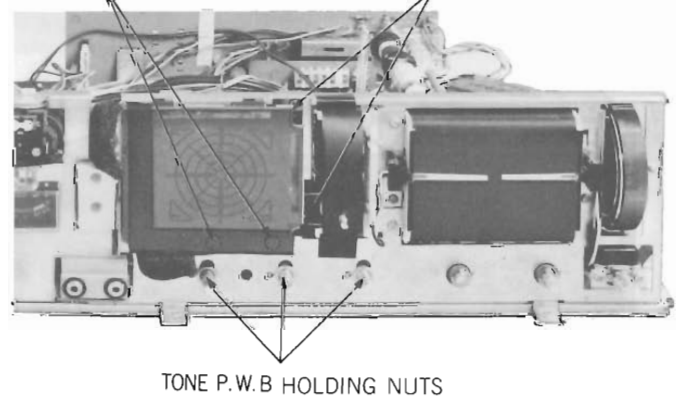

Fig. 8

DIAL CORD STRINGING

Referring to Fig. 9, loop the dial cord in the direction of arrows.

1. Dial cord : 0.6mmφ tetoron dial cord.
2. V.C position : Low freq. and (Fully clockwise)
3. Dial scale setting : Set the 0° of the scale to the dial pointer and fix the 0° point adjustment screw.

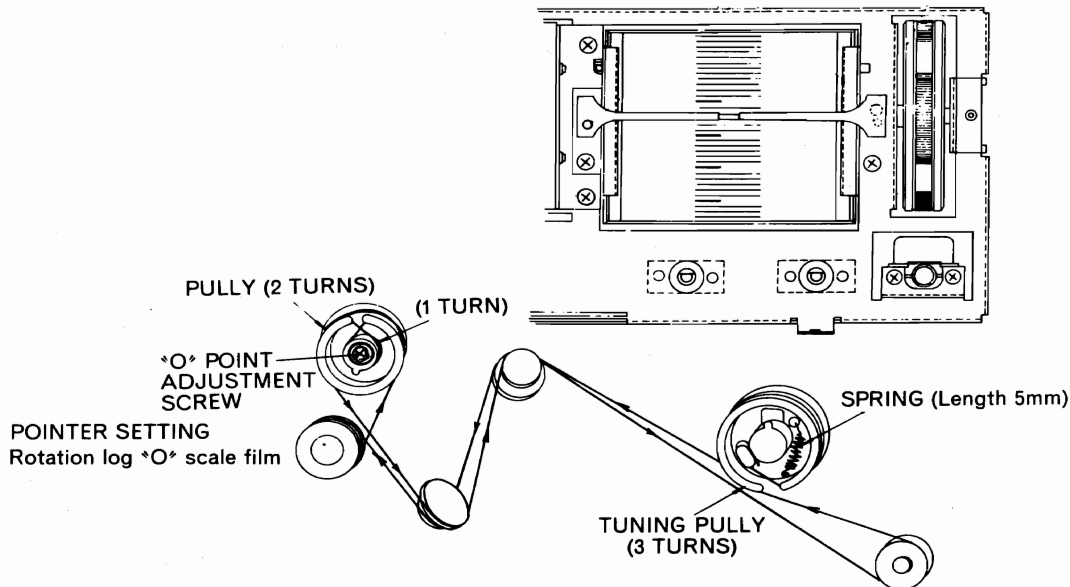

Fig. 9

LUBRICATION

Before lubrication, thoroughly clean shafts and metallic parts of turning mechanisms. During lubrication, be careful not to accidentally oil the tape contacting face of capstan, and the rubber portion of belts and idler.

One or two drops of machine oil may be applied to the points (M) Grease may be applied to the point (G) as shown in Fig. 10.

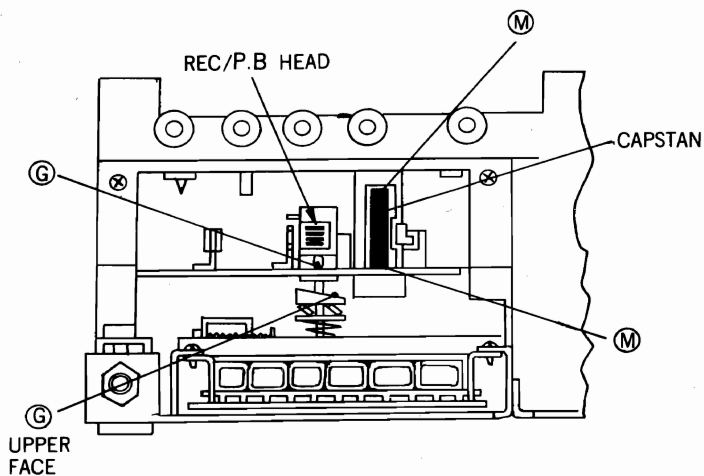

Fig. 10

ADJUSTMENT PROCEDURE

A. ADJUSTMENT OF 8 TRACK TAPE DECK

1. Adjustment of track position (head height) (Fig. 11.)

Playback track No. 2 of test cartridge (RCA # 321) (blank channel) in L channel and adjust the screw for head height adjustment so that the output may be minimum.

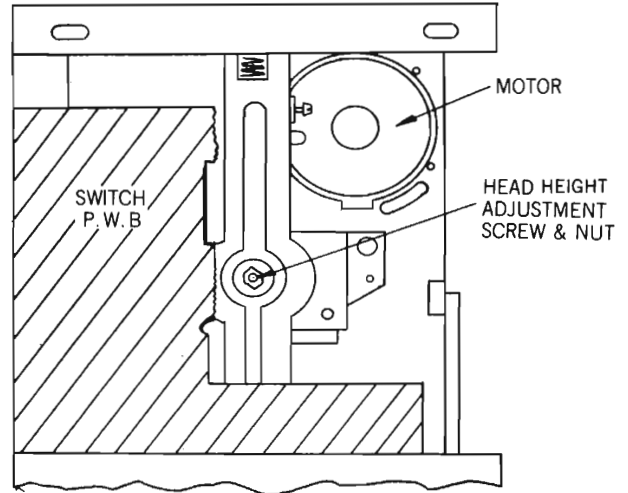
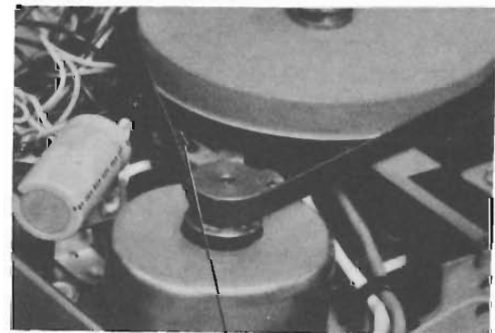

Fig. 11

2. Adjustment of head angle (Fig. 12.)

Playback track No. 6 of test cartridge (RCA # 321) (8 kHz) in R channel and adjust the screw for head angle adjustment so that the output may be within 2 dB of peak output. And repeat adjustment of track position.



ANGLE ADJUSTMENT SCREW

Fig. 12

3. Adjustment of output voltage

Playback the test cartridge (RCA 323) (SRL tape) and adjust RT801A (FR), RT801B (FL) RT830C (RR) and RT830D (RL) so that the output between P814A~D to P815 may be 200mV with V.T.V.M.

4. Adjustment of bias current and erasing current

Set the 8 track tape deck in recording function. Adjust RT802 so that the voltage drop across R817 (between P808 to P815) may be $1.7V \pm 0.05V$ with V.T.V.M.

B. ADJUSTMENT OF RADIO BLOCK

1. Adjustment of covering and tracking

Item	Adjustment Circuit	Dial Pointer Setting	Sig. Gen. Output	Adjustment Parts
1	FM-IF	High freq. end	10.7MHz \pm 1MHz sweep	T203, T202, T201, T103, T102
2	FM-DISCR.	High freq. end	10.7MHz \pm 1MHz sweep	T204

REPLACEMENT PARTS

Item	Adjustment Circuit	Dial Pointer Setting	Sig. Gen. Output	Adjustment Parts
3	AM-IF	High freq. end	455 kHz	T206, T205, T151
4	AM-RF.	Low freq. end	520 kHz	L152
		High freq. end	1,650 kHz	CT152
		600 kHz 1,400 kHz	600 kHz 1,400 kHz	L151 CT151
5	FM-RF	Low freq. end	87 MHz	L103
		High freq. end	109 MHz	CT103
		90 MHz 106 MHz	90 MHz 106 MHz	L103, L102 CT102, CT101

2. Adjustment of Multiplex Circuit

2-1. Adjustment of 19 kHz

- 1) Apply an output of 98 MHz, 60 dB from stereo signal generator to terminals P101, P102 of RF/IF circuit board. Make sure the pointer deflects to 98 MHz.
- 2) Set the degree of modulation of the pilot signal to 6 % and adjust RV301 so that the stereo indicator lamp turns on at this point.
- 3) Set the degree of modulation to 10 % and connect VTVM

to terminal No. 14 of IC301 and P310 (ground side).

Adjust L304 to maximize VTVM reading.

2-2. Adjustment of separation

Apply output of stereo signal generator (98 MHz, 60 dB, pilot signal 10 %, L+R signal 90 %) to terminals P101, P102 of RF/IF circuit board. Adjust L305 so that separation of output terminals P303, P305 of multiplex is maximized.

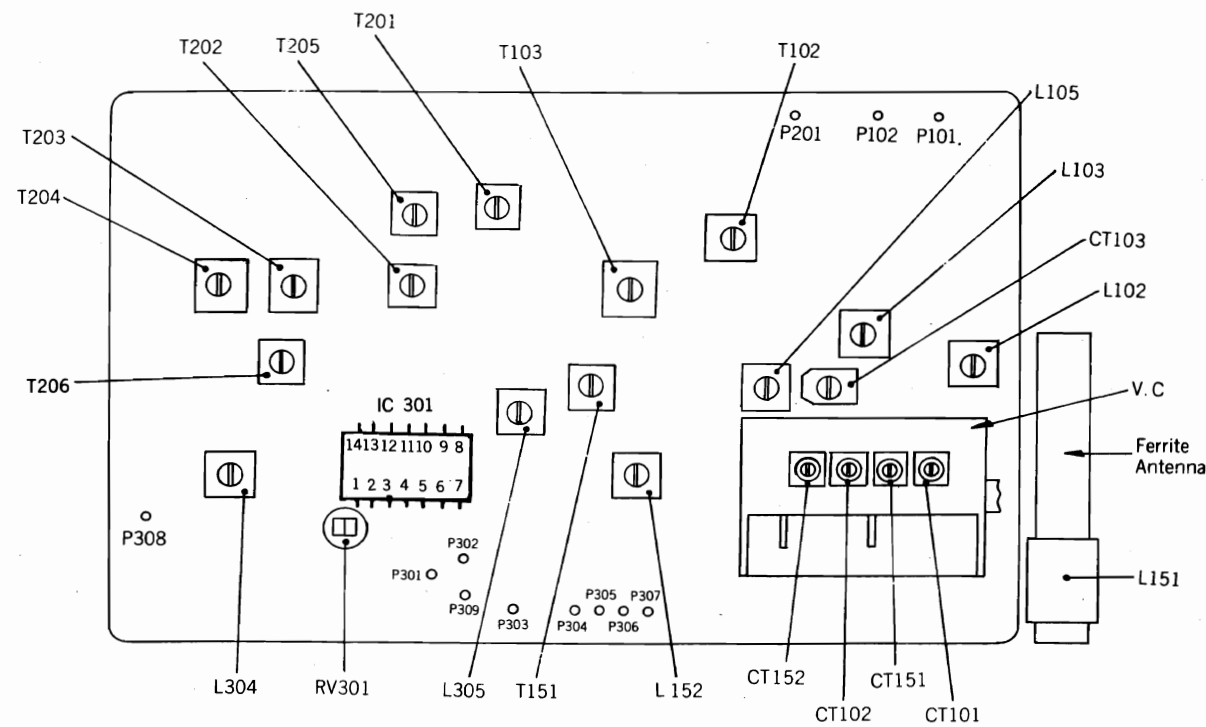
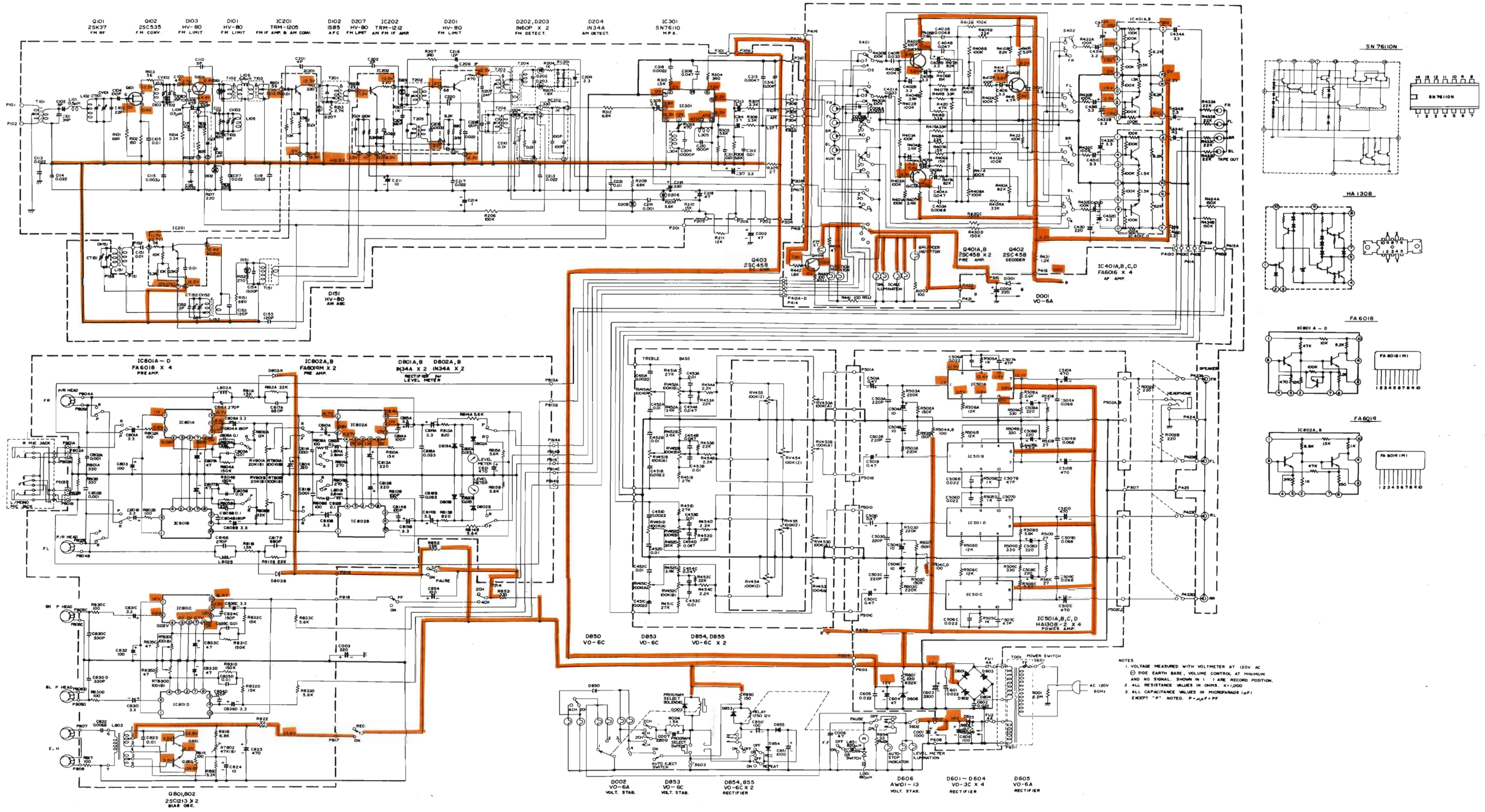

Fig. 13

Symbol No.	Stock No.	Description	Symbol No.	Stock No.	Description
CAPACITORS :					
C 001	0256010	Electrolytic	C 318	0274113	Mylar
C 002	0252525	Electrolytic	C 401A,B	0275114	Mylar
C 003	0252332	Electrolytic	C 402A,B	0252613	Electrolytic
C 004	0252632	Electrolytic	C 403A,B	0274016	Mylar
C 005	0252625	Electrolytic	C 404A,B	0275015	Mylar
C 006A,B	0274114	Mylar	C 405A,B	0252613	Electrolytic
C 007	0256099	Electrolytic	C 406	0252613	Electrolytic
C 101	0248714	Ceramic, disc	C 407	0252613	Electrolytic
C 102	0248645	Ceramic, disc	C 408A,B	0252613	Electrolytic
C 103	0248668	Ceramic, disc	C 430	0252632	Electrolytic
C 104	0248724	Ceramic, disc	C431A~D	0252613	Electrolytic
C 105	0244171	Ceramic, disc	C432A~D	0252613	Electrolytic
C 106	0248704	Ceramic, disc	C434A~D	0252613	Electrolytic
C 107	0248644	Ceramic, disc	C451A~D	0274113	Mylar
C 108	0248716	Ceramic, disc	C452A~D	0275111	Mylar
C 109	0248696	Ceramic, disc	C453A~D	0275111	Mylar
C 110	0248645	Ceramic, disc	C454A~D	0275115	Mylar
C 111	0248477	Ceramic, disc	C501A~D	0257040	Electrolytic
C 112	0248644	Ceramic, disc	C503A~D	0248732	Ceramic, disc
C 113	0249512	Ceramic, disc	C504A~D	0252621	Electrolytic
C 114	0249512	Ceramic, disc	C506A~D	0275113	Mylar
C 115	0249507	Ceramic, disc	C507A~D	0248716	Ceramic, disc
C 116	0275113	Mylar	C508A~D	0252232	Electrolytic
C 117	0275113	Mylar	C509A~D	0275116	Mylar
C 118	0275113	Mylar	C510A~D	0252535	Electrolytic
C 119	0244171	Ceramic, disc	C 601	0275113	Mylar
C 151	0244171	Ceramic, disc	C 602	0275113	Mylar
C 152	0249532	Ceramic, disc	C 603	0256107	Electrolytic
C 153	0248726	Ceramic, disc	C 604	0252525	Electrolytic
C 154	0217823	Polystyrol	C 605	0275113	Mylar
C 155	0248726	Ceramic, disc	C 606	0252531	Electrolytic
C 201	0248644	Ceramic, disc	C 801A,B	0252613	Electrolytic
C 202	0248643	Ceramic, disc	C 802A,B	0274111	Mylar
C 204	0248726	Ceramic, disc	C 803	0252531	Electrolytic
C 205	0274114	Mylar	C 804A,B	0248730	Ceramic, disc
C 206	0248641	Ceramic, disc	C 805A,B	0275111	Mylar
C 207	0248669	Ceramic, disc	C 806A,B	0276111	Mylar
C 208	0248726	Ceramic, disc	C 807A,B	0252525	Electrolytic
C 209	0252613	Electrolytic	C 808A,B	0252613	Electrolytic
C 210	0275111	Mylar	C 809	0252632	Electrolytic
C 211	0252621	Electrolytic	C 810A,B	0252613	Electrolytic
C 213	0275113	Mylar	C 811A,B	0274111	Mylar
C 214	0252611	Electrolytic	C 812A,B	0276111	Mylar
C 215	0252533	Electrolytic	C 813A,B	0252332	Electrolytic
C 216	0248702	Ceramic, disc	C 814A,B	0248724	Ceramic, disc
C 217	0275113	Mylar	C 815A,B	0252613	Electrolytic
C 218	0252525	Electrolytic	C 816A,B	0248694	Ceramic, disc
C 219	0274111	Mylar	C 817A,B	0249530	Ceramic, disc
C 220	0248642	Ceramic, disc	C 818A,B	0275114	Mylar
C 221	0244171	Ceramic, disc	C 819A,B	0252613	Electrolytic
C 305	0252613	Electrolytic	C 820A,B	0275112	Mylar
C 308	0275115	Mylar	C 821	0256008	Electrolytic
C 309	0217825	Polystyrol	C 822	0274116	Mylar
C 310	0217823	Polystyrol	C 823	0275011	Mylar
C 311	0275111	Mylar	C 824	0252621	Electrolytic
C 312	0275111	Mylar	C 825	0256008	Electrolytic
C 313	0252613	Electrolytic	C 830C,D	0248736	Ceramic, disc
C 314	0252613	Electrolytic	C 831C,D	0252613	Electrolytic
C 315	0274115	Mylar	C 832	0252631	Electrolytic
C 316	0274115	Mylar	C 833C,D	0252525	Electrolytic
C 317	0252613	Electrolytic			

SCHEMATIC DIAGRAM



CIRCUIT BOARD DIAGRAM

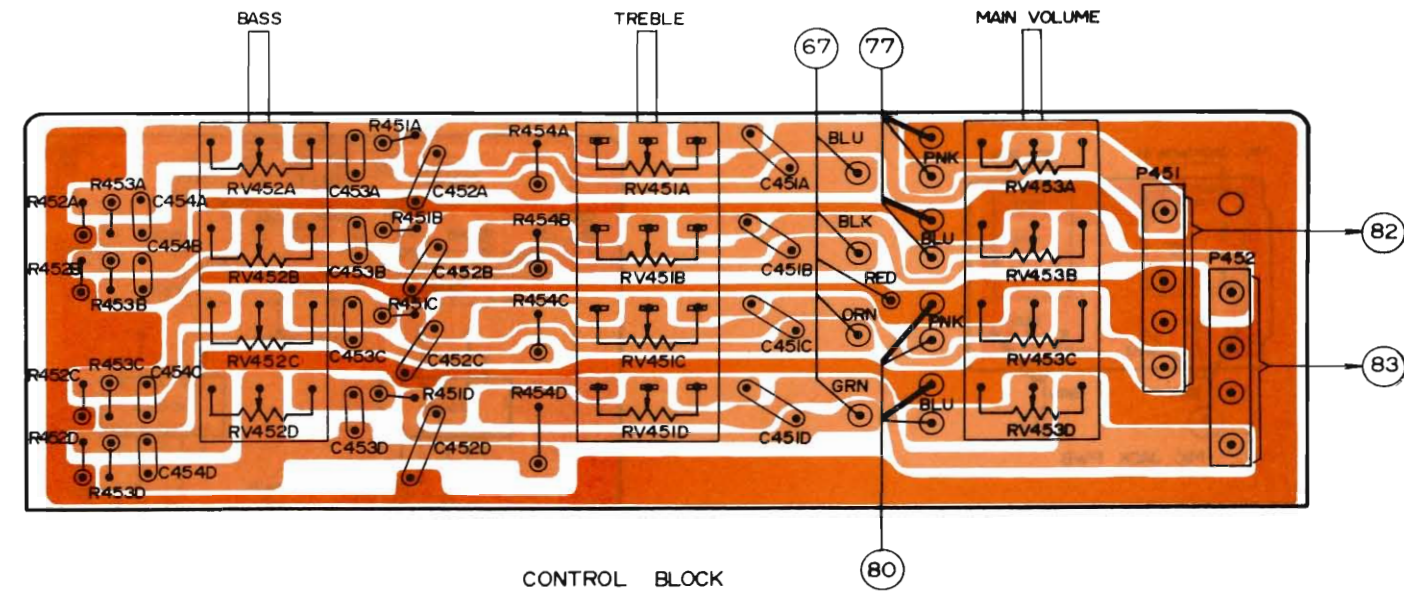
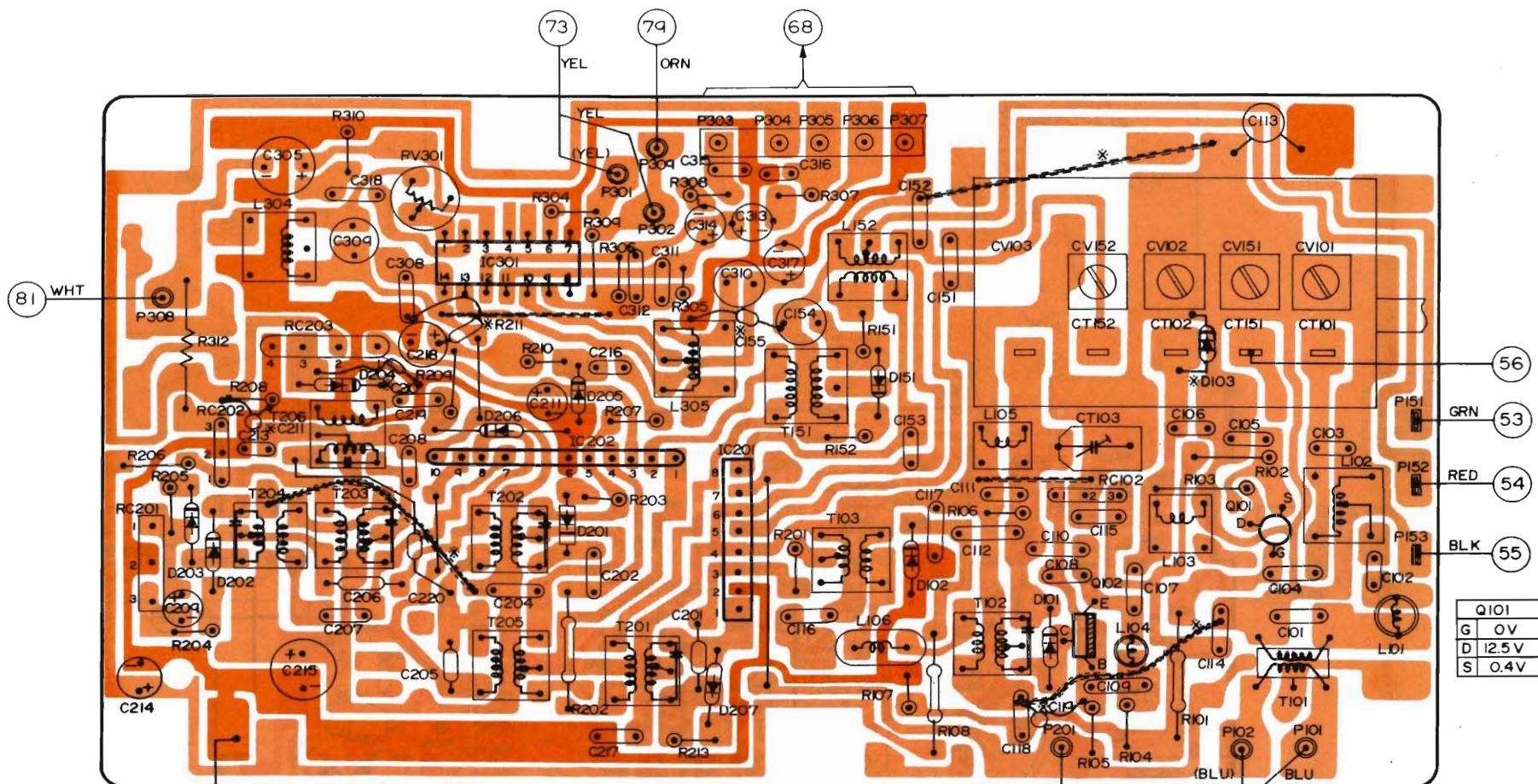

IC 301		
1	12V	8
2	2V	4
3	2.8V	10
4	—	11
5	—	12
6	7.8V	13
7	0V	14

IC 202			
1	12.5V	6	0V
2	1.5V	7	12.5V
3	1V	8	2V
4	1.3V	9	2V
5	12.5V	10	12.5V

IC 201			
1	12.5V	5	11.7V(27V)
2	0V	6	12.5V
3	12.5V	7	10V(0V)
4	12.5V	8	12.4V(8V)

Q102	
B	4.4V
C	12.4V
E	3.7V

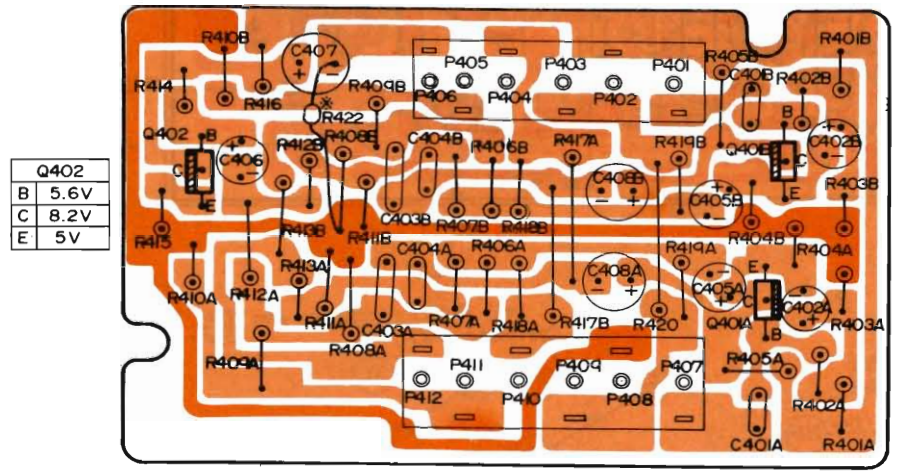

Q402	
B	5.6V
C	8.2V
E	5V

Q401A,B	
B	6.4V
C	7.5V
E	5.8V

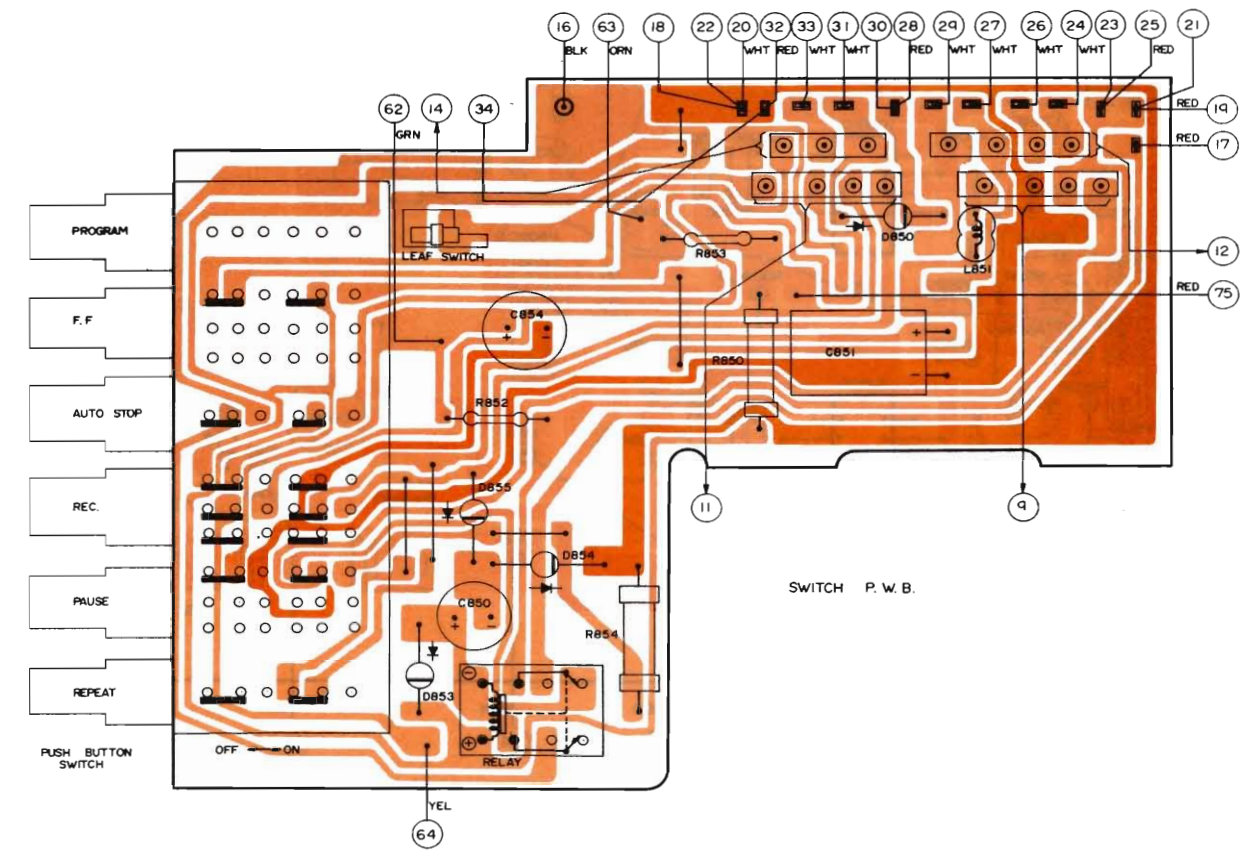
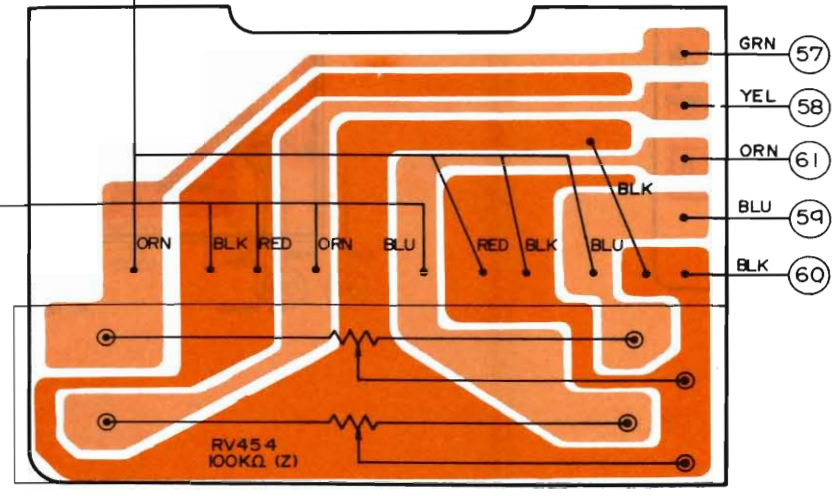

SQ P.W.B.

BALANCER P.W.B.

* are mounted on foil side.

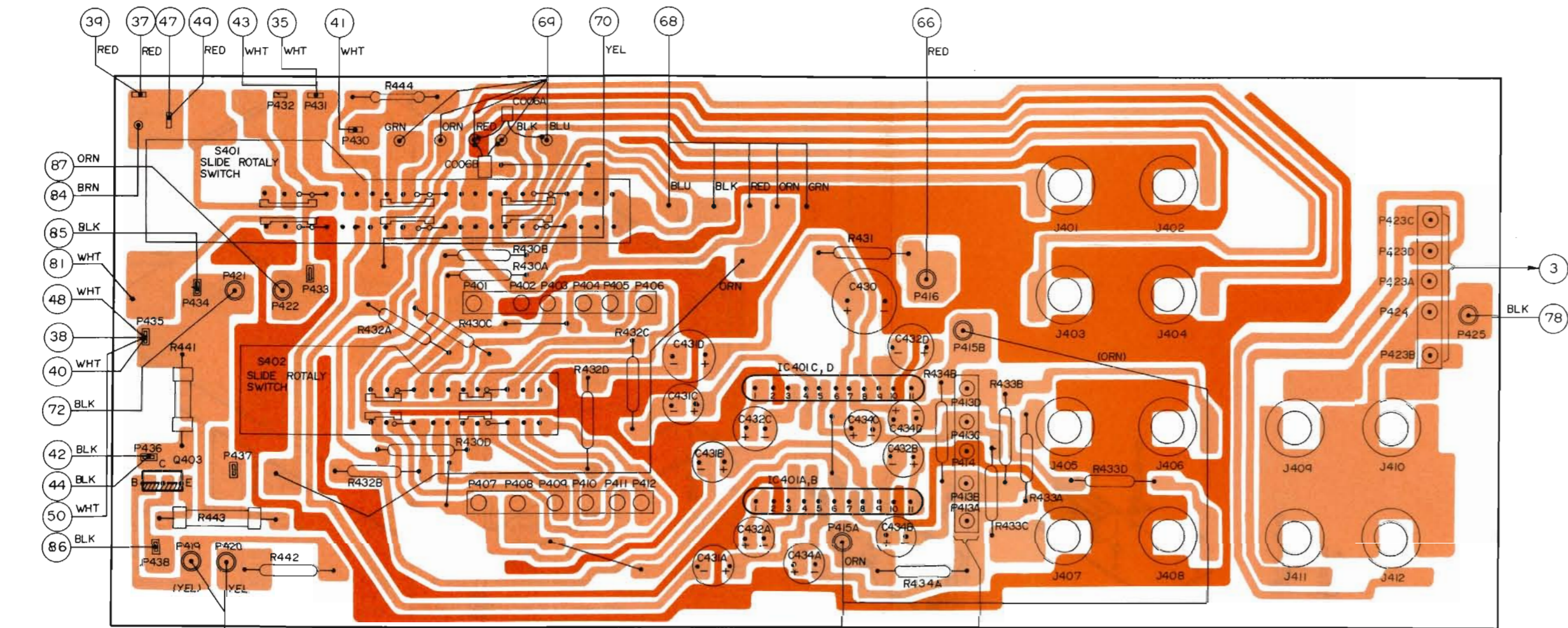

Q 403
B 7.8V
C 7.2V
E 0V

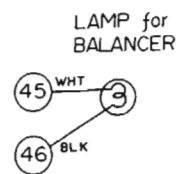
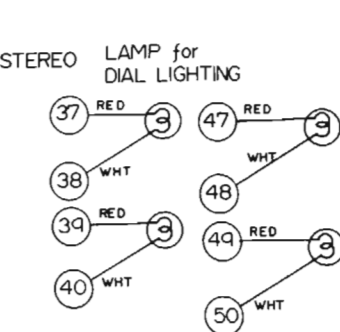
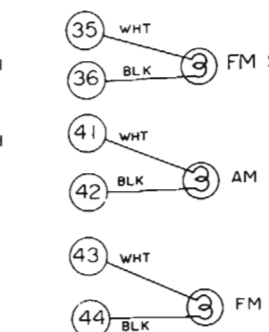
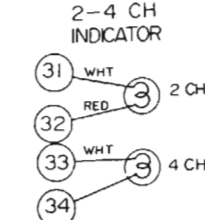
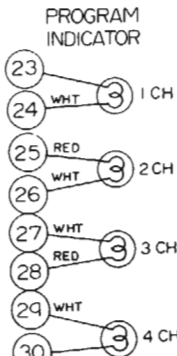
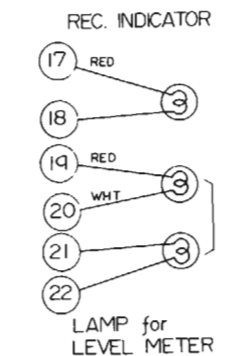
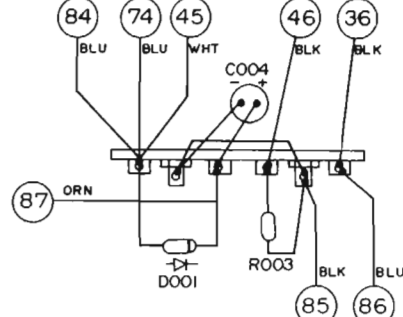
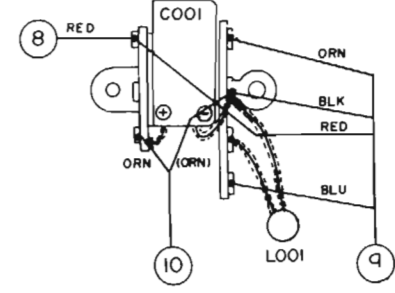
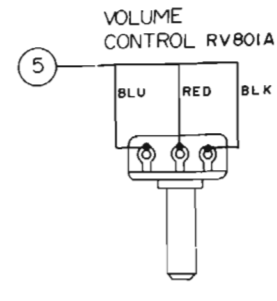
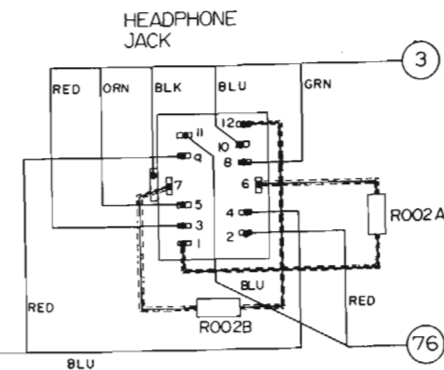
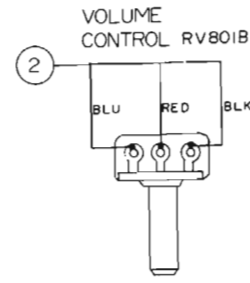
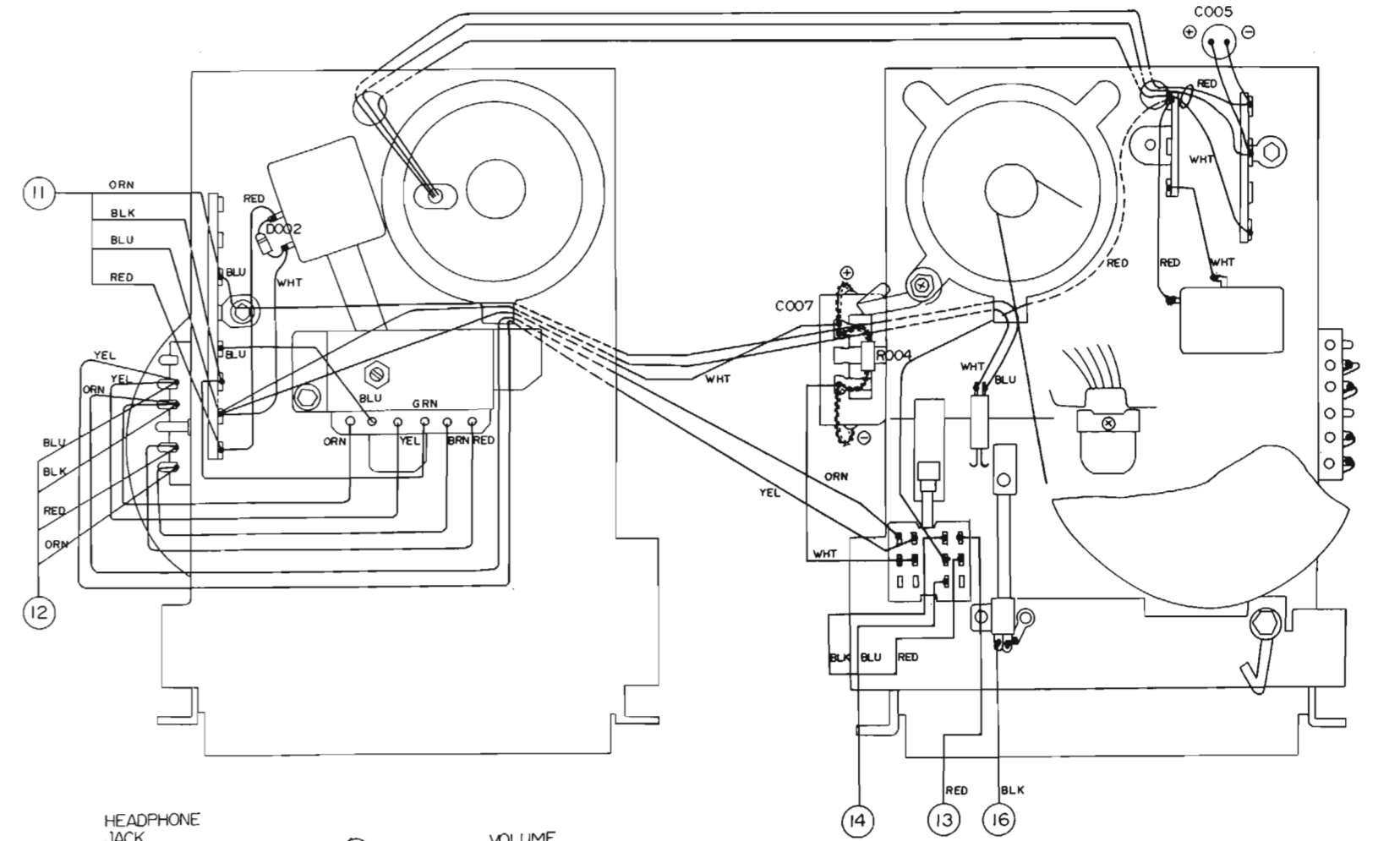
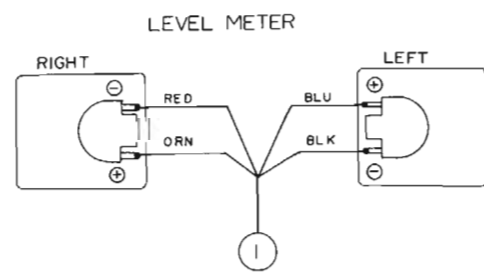
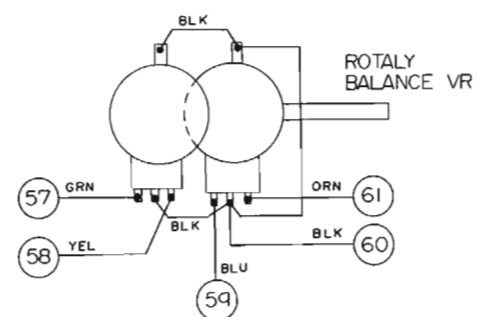
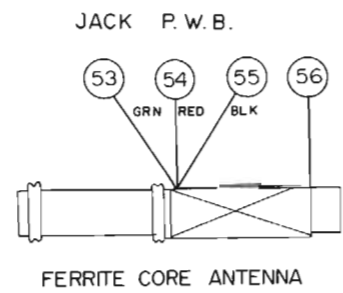
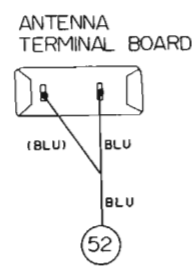
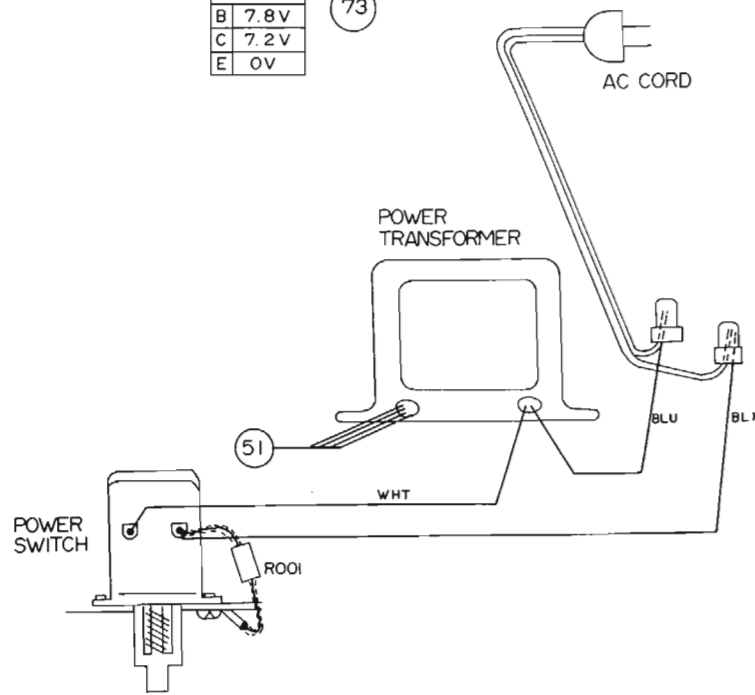

EXPLODED VIEW

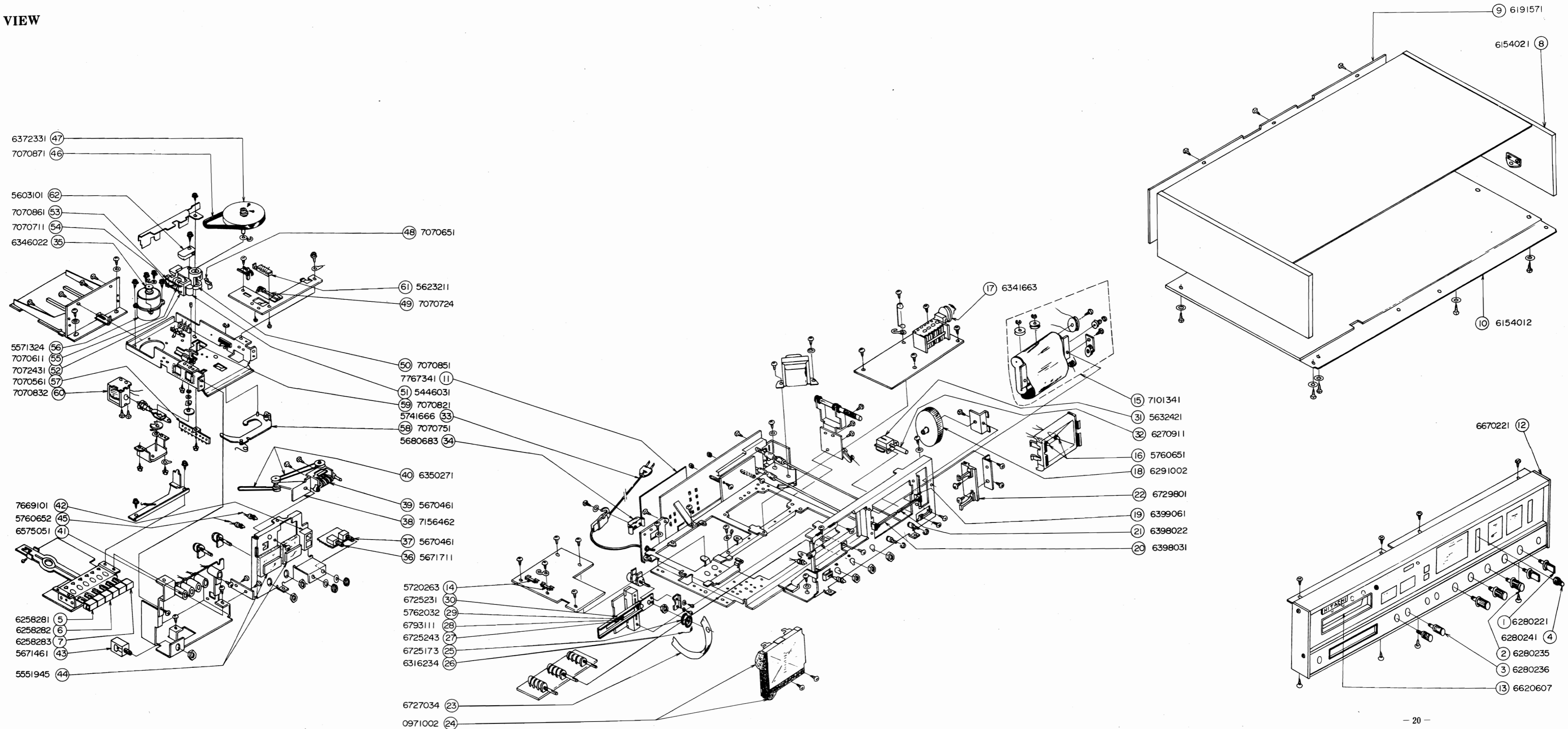

Symbol No.	Stock No.	Description			Symbol No.	Stock No.	Description		
C 834C.D	0248728	Ceramic, disc	150pF±10%		R 414	0137959	Carbon film	470kΩ±5%	¼SD
C 835C.D	0275111	Mylar	0.01μF±20%		R 415	0137859	Carbon film	4.7kΩ±5%	¼SD
C 836C.D	0252613	Electrolytic	3.3μF	25V	R 416	0137860	Carbon film	5.6kΩ±5%	¼SD
C 850	0252631	Electrolytic	100μF	25V	R 417A.B	0137912	Carbon film	82kΩ±5%	¼SD
C 851	0259670	Electrolytic	1000μF	6.3V	R 418A.B	0137907	Carbon film	33kΩ±5%	¼SD
C 854	0252531	Electrolytic	100μF	16V	R 419A.B	0137907	Carbon film	33kΩ±5%	¼SD
CT 103	0283113	Trimmer	8pF		R 420	0137909	Carbon film	47kΩ±5%	¼SD
CT101~102. 151.152 CV101~103. 151.152	0281583	Variable capacitor assembly			R 422	0137951	Carbon film	100kΩ±5%	¼SD
R 430A.B					0170291	Carbon film	100kΩ±5%	¼F	
RESISTORS :					R 430C.D	0170293	Carbon film	150kΩ±5%	¼F
R 001	0134704	Composition	2.2MΩ±20%	¼U	R 431	0170252	Carbon film	1.2kΩ±5%	¼F
R 002A.B	0134365	Composition	220Ω±10%	¼GF	R432A~D	0170291	Carbon film	100kΩ±5%	¼F
R 003	0111035	Metal oxide	100Ω±5%	1PA	R433A~D	0170275	Carbon film	22kΩ±5%	¼F
R 004	0137853	Carbon film	1.5kΩ±5%	¼SD	R 434A.B	0170293	Carbon film	150kΩ±5%	¼F
R 101	0170281	Carbon film	68kΩ±5%	¼F	R 441	0111035	Metal oxide	100Ω±5%	1PA
R 102	0137803	Carbon film	150Ω±5%	¼SD	R 442	0170254	Carbon film	1.8kΩ±5%	¼F
R 103	0137768	Carbon film	56Ω±5%	¼SD	R 443	0111035	Metal oxide	100Ω±5%	1PA
R 104	0137857	Carbon film	3.3kΩ±5%	¼SD	R 444	0170219	Carbon film	47Ω±5%	¼F
R 105	0137912	Carbon film	82kΩ±5%	¼SD	R451A~D	0137906	Carbon film	27kΩ±5%	¼SD
R 106	0137812	Carbon film	820Ω±5%	¼SD	R452A~D	0137858	Carbon film	3.9kΩ±5%	¼SD
R 107	0137805	Carbon film	220Ω±5%	¼SD	R453A~D	0137905	Carbon film	22kΩ±5%	¼SD
R 108	0170295	Carbon film	220kΩ±5%	¼F	R454A~D	0137855	Carbon film	2.2kΩ±5%	¼SD
R 151	0137811	Carbon film	680Ω±5%	¼SD	R502A~D	0137953	Carbon film	150kΩ±5%	¼SD
R 152	0137806	Carbon film	270Ω±5%	¼SD	R503A~D	0137955	Carbon film	220kΩ±5%	¼SD
R 201	0137768	Carbon film	56Ω±5%	¼SD	R504A~D	0137801	Carbon film	100Ω±5%	¼SD
R 202	0170215	Carbon film	22Ω±5%	¼F	R505A~D	0137851	Carbon film	1kΩ±5%	¼SD
R 203	0137851	Carbon film	1kΩ±5%	¼SD	R506A~D	0137902	Carbon film	12kΩ±5%	¼SD
R 204	0137851	Carbon film	1kΩ±5%	¼SD	R508A~D	0170260	Carbon film	5.6kΩ±5%	¼F
R 205	0137854	Carbon film	1.8kΩ±5%	¼SD	R509A~D	0137807	Carbon film	330Ω±5%	¼SD
R 206	0137951	Carbon film	100kΩ±5%	¼SD	R510A~D	0170215	Carbon film	22Ω±5%	¼F
R 207	0137808	Carbon film	390Ω±5%	¼SD	R 601	0111410	Metal oxide	220Ω±10%	2W
R 208	0114531	Carbon film	68kΩ±5%	¼P	R 602	0134363	Composition	150Ω±10%	½GF
R 209	0137860	Carbon film	5.6kΩ±5%	¼SD	R 801A.B	0137807	Carbon film	330Ω±5%	¼SD
R 210	0137903	Carbon film	15kΩ±5%	¼SD	R 802A.B	0137801	Carbon film	100Ω±5%	¼SD
R 211	0137902	Carbon film	12kΩ±5%	¼SD	R 804A.B	0137953	Carbon film	150kΩ±5%	¼SD
R 213	0137856	Carbon film	2.7kΩ±5%	¼SD	R 805A.B	0137907	Carbon film	33kΩ±5%	¼SD
R 304	0137808	Carbon film	390Ω±5%	¼SD	R 806A.B	0137902	Carbon film	12kΩ±5%	¼SD
R 305	0137860	Carbon film	5.6kΩ±5%	¼SD	R 808A.B	0137801	Carbon film	100Ω±5%	¼SD
R 306	0137860	Carbon film	5.6kΩ±5%	¼SD	R 809A.B	0137806	Carbon film	270Ω±5%	¼SD
R 307	0114467	Carbon film	3.3kΩ±5%	¼P	R 810A.B	0170273	Carbon film	15kΩ±5%	¼F
R 308	0114467	Carbon film	3.3kΩ±5%	¼P	R 811A.B	0137853	Carbon film	1.5kΩ±5%	¼SD
R 309	0137764	Carbon film	27Ω±5%	¼SD	R 812A.B	0137905	Carbon film	22kΩ±5%	¼SD
R 310	0137853	Carbon film	1.5kΩ±5%	¼SD	R 813A.B	0137812	Carbon film	820Ω±5%	¼SD
R 312	0114471	Carbon film	6.8kΩ±5%	¼P	R 814A.B	0137860	Carbon film	5.6kΩ±5%	¼SD
R 401A.B	0137951	Carbon film	100kΩ±5%	¼SD	R 815A.B	0137860	Carbon film	5.6kΩ±5%	¼SD
R 402A.B	0137951	Carbon film	100kΩ±5%	¼SD	R 817	0137801	Carbon film	100Ω±5%	¼SD
R 403A.B	0137951	Carbon film	100kΩ±5%	¼SD	R 818	0137861	Carbon film	6.8kΩ±5%	¼SD
R 404A.B	0137858	Carbon film	3.9kΩ±5%	¼SD	R 819	0137801	Carbon film	100Ω±5%	¼SD
R 405A.B	0137858	Carbon film	3.9kΩ±5%	¼SD	R 820	0137857	Carbon film	3.3kΩ±5%	¼SD
R 406A.B	0137903	Carbon film	15kΩ±5%	¼SD	R 822	0137763	Carbon film	22Ω±5%	¼SD
R 407A.B	0137903	Carbon film	15kΩ±5%	¼SD	R 830C.D	0137801	Carbon film	100Ω±5%	¼SD
R 408A.B	0137951	Carbon film	100kΩ±5%	¼SD	R 831C.D	0137953	Carbon film	150kΩ±5%	¼SD
R 409A.B	0137907	Carbon film	33kΩ±5%	¼SD	R 832C.D	0137903	Carbon film	15kΩ±5%	¼SD
R 410A.B	0137912	Carbon film	82kΩ±5%	¼SD	R 833C.D	0137860	Carbon film	5.6kΩ±5%	¼SD
R 411A.B	0137951	Carbon film	100kΩ±5%	¼SD	R 850	0171208	Metal oxide	150Ω±10%	2F
R 412A.B	0137951	Carbon film	100kΩ±5%	¼SD	R 852	0170277	Carbon film	33kΩ±5%	¼F
R 413A.B	0137951	Carbon film	100kΩ±5%	¼SD	R 853	0170237	Carbon film	330Ω±5%	¼F
					R 854	0190156	Wire wound	33Ω±10%	
					RC 102	0186415	CR Pack		
					RC 201	0186385	CR Pack		

Symbol No.	Stock No.	Description		Symbol No.	Stock No.	Description	
RC 202 RC 203	0186386 5065015	CR Pack CR Pack		TRANSFORMERS :			
RV 301	0151882	Semi variable	470Ω	T 001	5211293	Power	
RV451A~D	0151454	Variable (volume)	100kΩ (A)	T 101	0318543	FM RF	
RV452A~D	0151455	Variable (bass)	100kΩ (B)	T 102	0322236	FM IF	
RV453A~D	0151454	Variable (treble)	100kΩ (A)	T 103	5142007	FM IF	
RV 454	0171562	Variable	100kΩ (Z)	T 151	5132002	AM IF	
RV 455	5000072	Variable	100kΩ (Z)	T 201	0322203	FM IF	
RV801A,B	0151446	Variable (rec. vol.)	20kΩ (B)	T 202	0329602	FM IF	
RT801A,B	0151889	Semi variable	100kΩ (B)	T 203	0326026	FM IF	
RT 802	0151888	Semi variable	47kΩ (B)	T 204	0326028	FM IF	
RT830C,D	0151361	Semi variable	100kΩ (B)	T 205	0322115	AM IF	
SEMI-CONDUCTORS :				T 206	0322120	AM IF	
Q 101	5320702	Transistor	2SK37H	COILS :			
Q 102	0573511	Transistor	2SC535C	L 001	5152031	Choke	180μH
Q 401A,B	5320024	Transistor	2SC458LG-D	L 101	5123271	FM RF	0.5μH
Q 402	5320024	Transistor	2SC458LG-D	L 102	5123119	FM RF	
Q 403	5320064	Transistor	2SC458D	L 103	5126006	FM RF	
Q 801	5320612	Transistor	2SC1213B	L 104	5123271	FM RF	0.5μH
Q 802	5320612	Transistor	2SC1213B	L 105	0318041	FM RF	
IC 201	5354541	IC	TRM-1205	L 106	5152012	Choke	6.8μH
IC 202	5354601	IC	TRM-1212	L 151	5112553	Ferrite-core antenna	
IC 301	5351042	IC	SN-76110	L 152	5120174	AM oscillator	
IC401A~D	5353093	IC	FA6016	L 304	5120183	19kHz Tuner	
IC501A~D	5350136	IC	HA1308	L 305	5120189	38kHz Tuner	
IC801A~D	5353112	IC	FA6018M	L 801A,B	0333151	Fixed	3.6mH
IC802A, B	5353122	IC	FA6019M	L 802A,B	5120303	Trap	
D 001	5330104	Diode	VO6A	L 803	5260025	Oscillator	
D 002	7070692	Diode		L 851	5152124	Choke	820μH
D 101	5330261	Diode	HV80	for final assembly			
D 102	0575024	Diode	1S85	①	6280221	Knob-18mmφ (FUNCTION)	
D 103	5330261	Diode	HV80	②	6280235	Knob-19mmφ (TREBLE, BASS, & MAIN-VOLUME)	
D 151	5330261	Diode	HV80	③	6280236	Knob-19mmφ (REC-VOLUME)	
D 201	5330261	Diode	HV80	④	6280241	Knob-15mmφ (BALANCE-VOLUME)	
D 202	0575019	Diode	1N60P	⑤	6258281	Push button (REPEAT, PAUSE, AUTO STOP, & F.F)	
D 203	0575019	Diode	1N60P	⑥	6258282	Push button (REC.)	
D 204	0575001	Diode	1N34A	⑦	6258283	Push button (PROGRAM)	
D 205	0575005	Diode	1N60	⑧	6154021	Top cabinet	
D 206	0575005	Diode	1N60	⑧	7780146	Pan head screw with washer-4mmφ×16mm (5 req'd) for deck chassis assembly & top cabinet mounting	
D 207	5330261	Diode	HV80	⑨	6191571	Rear cover	
D 601	5330001	Diode	VO3C	⑩	6154012	Bottom cabinet with rubber leg	
D 602	5330001	Diode	VO3C	⑩	7666162	Rubber leg	
D 603	5330001	Diode	VO3C		7780143	Pan head screw with washer-4mmφ×10mm (8 req'd) for chassis assembly & 8 deck chassis assembly mounting	
D 604	5330001	Diode	VO3C	⑪	7767341	Pin jack cover	
D 605	5330104	Diode	VO6A	⑫	6670221	Front panel assembly with cartridge lid	
D 606	5330054	Diode	AW01-13	⑬	6620607	Cartridge lid	
D 801A,B	0575001	Diode	1N34A		8721406	Flat screw-3mmφ×6mm (4 req'd) for front metal mounting	
D 802A,B	0575001	Diode	1N34A		8745406	Bind screw-3mmφ×6mm	
D 803A,B	5330131	Diode	1S2076	for chassis assembly			
D 850	5330101	Diode	VO6C		8721406	Flat screw-3mmφ×6mm (2 req'd) for balancer mounting	
D 853	5330101	Diode	VO6C		8721114	Nut-3mmφ (2 req'd) for SQ P.W.B. mounting	
D 854	5330101	Diode	VO6C	⑭	5720263	Fuse (4A)	
D 855	5330101	Diode	VO6C	⑮	7101341	Tuning drum assembly	
					8711404	Pan head screw-3mmφ×4mm (2 req'd) for tuning assembly mounting	
				⑯	5760651	Lamp (2 req'd) for dial indicator	

Symbol No.	Stock No.	Description	Symbol No.	Stock No.	Description
			for 8 deck chassis assembly (4CH)		
⑰	6341663	Pulley	④⑥	7070871	Belt
	6316236	Spring (M)	④⑦	6372331	Flywheel
⑱	6291002	Knob assembly (TUNING)		7070784	Spacer
⑲	6399061	Bracket (2 req'd) for pointer		7070773	Washer
⑳	6398031	Pointer		7070935	Screw (AM)
㉑	6398022	Pointer assembly	④⑧	7070651	Lever for Motor switch
	5762032	Lamp for pointer		7070911	Screw (B)
㉒	6729801	Spacer guide	④⑨	7070724	Motor switch
㉓	6727034	Slide spacer		7070921	Screw (C)
㉔	0971002	Rubber cushion		7070591	Spring (B)
	5760651	Lamp (2 req'd) for balance scale plate	⑤①	7070851	Flywheel holder
㉕	6725173	Pulley (B)	⑤②	5446031	Head
	7586881	Lock screw for pulley (B) mounting		7072431	Block head
㉖	6316234	Spring (M)		7072441	Set screw
㉗	6725243	Lamp slider	⑤③	7070861	Arm
㉘	6793111	Indicator	⑤④	7070711	Arm for head holder
	6576011	Rubber plate		7070621	Spring holder
㉙	5762032	Pilot lamp for balance indicator	⑤⑤	7070611	Spring (A)
㉚	6725231	Bushing for pilot lamp (balance indicator)		7072452	Head connector
㉛	5632421	Power switch	⑤⑥	5571324	DC Motor
㉜	6270911	Knob assembly (POWER)		7070934	Screw (AM)
㉝	5741666	AC cord		7070933	Screw (AM)
㉞	0043793	Bushing		7070671	Bracket
㉟	5680683	Antenna terminal plate	⑤⑦	7070581	Lug terminal
	7444091	Clip antenna (Line cord antenna)		7070741	Spacer guide (L)
	6724792	U Joint		7070731	Spacer guide (R)
for 8 deck chassis assembly (4 CH)			⑤⑧	7070561	Terminal plate
⑳⑤	6346022	Motor pulley for flywheel		7070936	Screw (AM)
	0711305	Pan head screw-2.6mmφ×5mm (2 req'd) for motor pulley mounting	⑤⑨	7070751	Spring lever
	8781438	Tapping screw-3mmφ×8mm (2 req'd) for 8 deck P.W.B. mounting		7070821	Eject lever
	8711404	Pan head screw-3mmφ×4mm (2 req'd) for switch P.W.B. mounting		7070805	Washer
	8781638	Tapping screw-4mmφ×8mm (4 req'd) for 8 deck mounting		7070601	Pin
㉞⑥	5671711	Jack for microphone with switch	⑥①	7070931	Screw (AM)
㉞⑦	5670461	Jack for microphone		7070842	Cam shaft
	0948896	Jack washer		7070932	Screw (AM)
	0948771	Insulating washer (2 req'd) for jack (microphone)		7070571	Spring
	6324832	F, F spring	⑥②	7070832	Solenoid (bracket)
㉞⑧	7156462	Counter bracket assembly		7070941	Screw (M)
㉞⑨	5552082	Counter (TIMER)		5623211	Switch (2 CH/4 CH SELECTOR)
	8711404	Pan head screw-3mmφ×4mm (2 req'd) for counter and counter bracket mounting	⑥②	5603101	Switch for power
㉞⑩	6350271	Counter belt	for P. W. B. assembly		
㉞⑪	6575051	Lamp holder (4 req'd) for lamp (program indicator)	S 402	5610521	Rotary slide switch
	7669101	Rubber plate for lamp (channel indicator)	S 401	5610563	Rotary slide switch
	5760652	Lamp (2 req'd) for channel indicator and (4 req'd) for program indicator		5636051	Push switch
㉞⑬	5671461	Headphone jack for 4 ch.		5632802	Leaf switch
㉞⑭	5551945	Level meter		5640414	Relay
㉞⑮	5760652	Lamp (2 req'd) for level meter	S 801A,B	5620602	Slide switch
The parts shown below are supplied by HSC (LA)					
				LA6508111	Speaker box Ass'y (with label, speaker, cableplug)
				LA6502061	Grill cloth Ass'y
				LA5703041	Speaker
				LA7700051	Screw, for speaker mounting
				LA5702001	Speaker cord (12')
				LA5702011	Speaker cord (24')



Head Office : 5-1. 1 chome. Marunouchi, Chiyoda-ku, Tokyo
Tel. Tokyo (212) 1111 (80 lines)

Cable Address : ◆HITACHY◆ TOKYO

Codes : All Codes Used

Printed in Japan
Sep. '74 (Y)