



# HITACHI

# SR-604

## SERVICE MANUAL

English  
Deutsch  
Français

No. 164

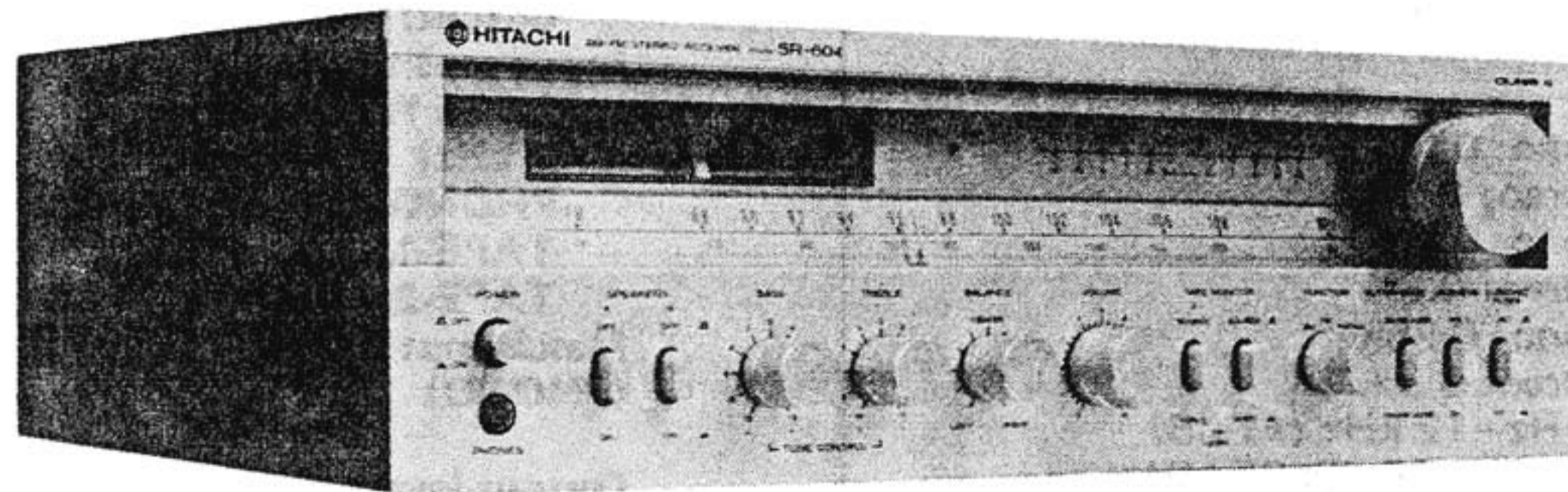

### FEATURES

#### Amplifier Section

1. Newly Developed High-Efficiency High-Power Audio Amplifier (Class G Amplifier or Dynaharmony Amplifier)
2. Direct-connection OCL Power Amplifier
3. 10-LED power indication
4. Electronic Protection Circuit
5. Subsonic Filter
6. Detent Type VOLUME and BALANCE Controls
7. Equalizer circuit with high-performance IC
8. Tape Dubbing
9. Two Speaker Systems Connection

#### Tuner Section

1. Dual Gate MOS FET for High Quality FM Tuner
2. High Selectivity and Low Distortion IF Amplifier Using IC and 3 Ceramic Filters
3. Quadrature Detection
4. Phase-Locked Loop for FM/MPX Circuit
5. Ceramic Filter, IC in AM Tuner
6. Two Large Easy-to-Read Meters and a Large-sized Fly-wheel Tuning Knob

### MERKMALE

#### Verstärker-Teil

1. Neuentwickelter Hochleistungs-Audioverstärker der G-Klasse (Dynaharmony)
2. Direkt gekoppelter OCL-Leistungsverstärker
3. 10 LED-Leistungskontrollen
4. Elektronische Schutzschaltung
5. Subsonic-Filter
6. Defeat-Lautstärke (VOLUME) und BALANCE-Regler
7. Entzerrerschaltung mit leistungsfähigem IC
8. Bandaufnahme vom Original
9. Anschluß für zwei Boxenpaare

#### Tuner-Teil

1. Dual-Gate MOS FET
2. Verzerrungsarmer ZF-Verstärker mit hoher Trennschärfe, bestückt mit IC und drei Keramikfiltern
3. Quadraturdemodulator
4. Phasenstarre Schleifenschaltung (PLL IC) im UKW-Multiplex-Schaltkreis
5. Keramikfilter und IC im MW-Tuner
6. Zwei große, leicht lesbare Anzeigeeinstrumente und ein großformatiger Schwungrad-Abstimmknopf

### CARACTERISTIQUES

#### Section Amplificateur

1. Amplificateur audio à grande puissance et à haute efficacité nouvellement mis au point (Amplificateur de classe G) (Dynaharmonique)
2. Amplificateur de puissance à circuit OCL et à connexion directe
3. Indication de puissance par 10 diodes
4. Circuit électronique de protection
5. Filtre subsonique
6. Commande d'équilibrage et de VOLUME de type à détent
7. Un circuit de correction acoustique avec circuit intégré de haute performance
8. Copiage de bande
9. Connexion de deux enceintes

#### Section Tuner

1. MOS FET à double porte pour un Tuner FM de qualité élevée
2. Amplificateur FI à faible niveau de distorsion et à haute sélectivité employant des circuits intégrés et trois filtres céramiques
3. Détection quadriphonique
4. Boucle à blocage de phase pour le circuit FM/MPX
5. Un filtre céramique, circuit intégré dans le tuner AM
6. Deux indicateurs à lecture facile et un bouton de syntonisation utilisant un volant de large dimension

## STEREO RECEIVER

## March 1979

# SPECIFICATIONS

## ● FM SECTION

<b>Frequency range</b>	88—108 MHz
<b>Usable sensitivity</b>	Mono: 10.3 dBf (1.8 $\mu$ V) Stereo: 21 dBf (6.2 $\mu$ V) ( ) is indicated IHF '58
<b>50 dB Quieting sensitivity</b>	Mono: 17 dBf (3.9 $\mu$ V) Stereo: 37 dBf (39 $\mu$ V) ( ) is indicated IHF '58
<b>Signal-to-noise ratio (at 65 dBf)</b>	Mono: 74 dB Stereo: 68 dB
<b>Harmonic distortion (at 65 dBf)</b>	
<b>100 Hz</b>	Mono: 0.2% Stereo: 0.3%
<b>1 kHz</b>	Mono: 0.15% Stereo: 0.3%
<b>10 kHz</b>	Mono: 0.25% Stereo: 0.3%
<b>Frequency response</b>	30 Hz—12 kHz ( $\pm$ 1 dB)
<b>Image response ratio</b>	90 MHz: 56 dB, 98 MHz: 50 dB, 106 MHz: 45 dB
<b>Spurious response ratio</b>	80 dB
<b>IF response ratio</b>	80 dB
<b>Alternate channel selectivity</b>	76 dB
<b>Capture ratio</b>	1 dB
<b>AM suppression</b>	50 dB
<b>Stereo separation</b>	45 dB (1 kHz)
<b>Sub carrier suppression</b>	50 dB
<b>SCA rejection</b>	60 dB
<b>Muting threshold</b>	21 dBf (6.2 $\mu$ V)
<b>Antenna input</b>	300 ohms balanced 75 ohms unbalanced (except for U.S.A. and Canada)

## ● AM SECTION

<b>Frequency range</b>	530—1,605 kHz
<b>Sensitivity</b>	300 $\mu$ V/m (S/N 20 dB), 20 $\mu$ V (IHF, ext. Antenna)
<b>Image rejection</b>	50 dB
<b>IF rejection</b>	40 dB
<b>Selectivity (IHF)</b>	34 dB
<b>Signal-to-noise ratio</b>	45 dB
<b>Antenna</b>	Ferrite antenna and Separate terminal

## ● AUDIO SECTION

<b>Output RMS power (Both channels driven)</b>	35 watts per channel, min. RMS, at 8 ohms from 20 Hz to 20 kHz, with no more than 0.05% total harmonic distortion. 40 W + 40 W (8 ohms, 1 kHz, T.H.D. 0.05%) 45 W + 45 W (4 ohms, 1 kHz, T.H.D. 0.05%)
<b>Non-clipped transient power</b>	70 W + 70 W (1 kHz, T.H.D. 0.05%)
<b>Power bandwidth</b>	10 Hz—30 kHz (1/2 RMS power, T.H.D. 0.05% at 8 ohms)

<b>Frequency characteristics</b>	10 Hz—30 kHz ( $\pm$ 2 dB)
<b>Harmonic distortion (at rated output)</b>	Less than 0.05%
<b>(at 1/2 rated output)</b>	Less than 0.03%
<b>Intermodulation distortion (at rated output)</b>	0.05%
<b>(at 1/2 rated output)</b>	0.03%
<b>Input sensitivity (at 35 W output, 1 kHz)</b>	
<b>PHONO</b>	3 mV (50 k ohms)
<b>TAPE-1</b>	150 mV (60 k ohms)
<b>TAPE-2</b>	150 mV (60 k ohms)
<b>Max. input level (PHONO)</b>	140 mV (T.H.D. 0.1% at 1 kHz)
<b>Output level TAPE OUT</b>	150 mV (PHONO at rated input) 150 mV (FM 400 Hz, 30% dev. input: 1 mV) 150 mV (AM 400 Hz, 30% mod. input: 5 mV/m)
<b>Signal-to-noise ratio (IHF, A network, rated power)</b>	
<b>PHONO</b>	70 dB
<b>TAPE</b>	90 dB
<b>Damping factor</b>	40 (1 kHz, 8 ohms)
<b>Equalizer</b>	RIAA $\pm$ 0.5 dB
<b>Bass control</b>	$\pm$ 10 dB (50 Hz)
<b>Treble control</b>	$\pm$ 10 dB (10 kHz)
<b>Loudness control</b>	+9 dB (100 Hz), +4 dB (10 kHz)
<b>Subsonic filter (-12 dB/oct)</b>	-3 dB (20 Hz), -15 dB (10 Hz)
<b>10 LED's power indicator</b>	Provided (L&R)
<b>FM Mode</b>	FM AUTO — MONO
<b>FM Muting</b>	Provided
<b>Tape monitor</b>	2
<b>Tuning meter</b>	2 (Signal, Tuning)
<b>Speaker switch</b>	A, B, A+B
<b>AC outlet</b>	1 (200 W unswitched) (for U.S.A., Canada & some countries)
<b>Power requirements</b>	AC 120 V 60 Hz ~120 V/220 V/240 V 50/60 Hz
<b>Power consumption</b>	195 W (120 V), 330 W (220/240 V)
<b>Dimensions</b>	435 (W) x 144 (H) x 350 (D) mm 17-1/8 (W) x 5-2/3 (H) x 13-5/6 (D) in.
<b>Weight</b>	8 kg (17.6 lbs.)

Specifications and design may be changed without notice for improvement.

# TECHNISCHE DATEN

## ● UKW-TEIL

Wellenbereich	88—108 MHz
Empfindlichkeit	Mono: 10,3 dBf (1,8 $\mu$ V) Stereo: 21 dBf (6,2 $\mu$ V) ( ) zeigt IHF '58 an.
50 dB Empfindlichkeitsschwelle	Mono: 17 dBf (3,9 $\mu$ V) Stereo: 37 dBf (39 $\mu$ V) ( ) zeigt IHF '58 an.
Geräuschspannungsabstand (bei 65 dBf)	Mono: 74 dB Stereo: 68 dB
Klirrfaktor (bei 65 dBf)	
100 Hz	Mono: 0,2% Stereo: 0,3%
1 kHz	Mono: 0,15% Stereo: 0,3%
10 kHz	Mono: 0,25% Stereo: 0,3%
Frequenzgang	30 Hz—12 kHz ( $\pm 1$ dB)
Spiegelselektion	90 MHz: 56 dB, 98 MHz: 50 dB, 106 MHz: 45 dB
Nebenwellenunterdrückung	80 dB
ZF-Dämpfung	80 dB
Wechselkanaltrennschärfe	76 dB
Einfangverhältnis	1 dB
AM-Unterdrückung	50 dB
Kanaltrennung	45 dB (1 kHz)
Zwischenträgerunterdrückung	50 dB
SCA-Unterdrückung	60 dB
Stillabstimmchwelle	21 dBf (6,2 $\mu$ V)
Antenneneingang	300 Ohm abgeglichen, 75 Ohm nicht abgeglichen (außer USA und Kanada)

## ● MW-TEIL

Wellenbereich	530—1 605 kHz
Empfindlichkeit	300 $\mu$ V/m (S/N 20 dB), 20 $\mu$ V (IHF, Außenantenne)
Spiegelselektion	50 dB
ZF-Dämpfung	40 dB
Selektivität (IHF)	34 dB
Geräuschspannungsabstand	45 dB
Antenne	Ferritantenne und separate Anschlußklemme

## ● AUDIO-TEIL

Ausgang	
Sinusleistung (beide Kanäle betrieben)	35 W/K + 35 W/K (8 Ohm, 20 Hz—20 kHz, Gesamtklirrfaktor 0,05%) 40 W/K + 40 W/K (8 Ohm, 1 kHz, 0,05%) 45 W/K + 45 W/K (4 Ohm, 1 kHz, 0,05%)
Nicht abgeschnittene zeitweilige Leistung	70 W + 70 W (1 kHz, Gesamtklirrfaktor 0,05%)
Ausgangs-Bandbreite	10 Hz—30 kHz (1/2 Sinusleistung, Gesamtklirrfaktor 0,05% bei 8 Ohm)

Frequenzumfang	10 Hz—30 kHz ( $\pm 2$ dB)
Klirrfaktor (bei Nennleistung)	Kleiner als 0,05%
(bei halber Leistung)	Kleiner als 0,03%
Intermodulations-Verzerrung (bei Nennleistung)	0,05%
(bei halber Leistung)	0,03%
Eingangsempfindlichkeit (bei 35 W Ausgangsleistung, 1 kHz)	
PHONO	3 mV (50 kOhm)
TAPE-1	150 mV (60 kOhm)
TAPE-2	150 mV (60 kOhm)
Max. Eingangspegel (PHONO)	140 mV (Gesamtklirrfaktor 0,1% bei 1 kHz)
Ausgangspegel	
TAPE OUT	150 mV (PHONO bei Nennleistungsleistung) 150 mV (UKW 400 Hz, 30% Dev. Eingang: 1 mV) 150 mV (MW 400 Hz, 30% Mod. Eingang: 5 mV/m)
Geräuschspannungsabstand (IHF, A-Netz, Nennleistung)	
PHONO	70 dB
TAPE	90 dB
Dämpfungsfaktor	40 (1 kHz, 8 Ohm)
Entzerrung	RIAA $\pm 0,5$ dB
Tiefeneinstellung	$\pm 10$ dB (50 Hz)
Höheneinstellung	$\pm 10$ dB (10 kHz)
Gehörriichtige Lautstärkekontur	+9 dB (100 Hz), +4 dB (10 kHz)
Subsonic-Filter (-12 dB/Okt.)	-3 dB (20 Hz), -15 dB (10 Hz)
Leistungsanzeige mit 10 LEDs	Vorhanden (L und R)
UKW-Betriebsart	UKW AUTO-MONO
UKW-Stummabstimmung	Vorhanden
Hinterbandkontrolle	2
Abstimmanzeige	2 (Feldstärke/Abstimmung)
Lautsprecherwähler	A, B, A+B
Wechselstromsteckdose	1 (200 W - Abgeschaltet) (Für U.S.A., Kanada und einige andere Länder)
Netzspannung	Wechselstrom 120 V 60 Hz $\sim 120$ V/220 V/240 V/50/60 Hz
Leistungsaufnahme	195 W (120 V), 330 W (220/240 V)
Abmessungen	435 (B) x 144 (H) x 350 (T) mm
Gewicht	8 kg

Änderungen der technischen Daten bleiben im Sinne der ständigen Verbesserung vorbehalten.

## CARACTERISTIQUES TECHNIQUES

### ● SECTION FM

<b>Bande de fréquences utilisable</b>	88 — 108 MHz
<b>Sensibilité utilisable</b>	Mono: 10,3 dBf (1,8 $\mu$ V) Stéréo: 21 dBf (6,2 $\mu$ V) Les ( ) sont pour l'IHF '58
<b>Seuil de sensibilité 50 dB</b>	Mono: 17 dBf (3,9 $\mu$ V) Stéréo: 37 dBf (39 $\mu$ V) Les ( ) sont pour l'IHF '58
<b>Rapport signal/bruit (65 dBf)</b>	Mono: 74 dB Stéréo: 68 dB
<b>Distorsion harmonique (65 dBf)</b>	
100 Hz	Mono: 0,2% Stéréo: 0,3%
1 kHz	Mono: 0,15% Stéréo: 0,3%
10 kHz	Mono: 0,25% Stéréo: 0,3%
<b>Réponse en fréquence</b>	30 Hz—12 kHz ( $\pm 1$ dB)
<b>Rapport de sélectivité</b>	90 MHz: 56 dB 98 MHz: 50 dB 106 MHz: 45 dB
<b>Rapport de réception non sélective</b>	80 dB
<b>Taux de réponse FI</b>	80 dB
<b>Sélectivité du canal de rechange</b>	76 dB
<b>Rapport de captage</b>	1 dB
<b>Suppression AM</b>	50 dB
<b>Séparation stéréo</b>	45 dB (1 kHz)
<b>Filtrage de la sous-porteuse</b>	50 dB
<b>Réjection SCA</b>	60 dB
<b>Seuil de sourdine</b>	21 dBf (6,2 $\mu$ V)
<b>Entrée de l'antenne</b>	300 ohms pondérés 75 ohms non-équilibrés (Sauf pour U.S.A. et Canada)

### ● SECTION AM

<b>Bande de fréquence</b>	530 — 1 605 kHz
<b>Sensibilité</b>	300 $\mu$ V/m (S/B 20 dB) 20 $\mu$ V (Antenne ext., IHF)
<b>Rejet image</b>	50 dB
<b>Rejet FI</b>	40 dB
<b>Sélectivité (IHF)</b>	34 dB
<b>Rapport signal/bruit</b>	45 dB
<b>Antenne</b>	Antenne de ferrite et borne séparée

### ● SECTION AUDIO

<b>Sortie</b>	
<b>Puissance nominale (Les deux canaux en fonctionnement)</b>	35 W + 35 W (8 ohms, 20 Hz—20 kHz, D.H.T. 0,05%) 40 W + 40 W (8 ohms, 1 kHz, D.H.T. 0,05%) 45 W + 45 W (4 ohms, 1 kHz, D.H.T. 0,05%)
<b>Puissance transistor non écrêtée</b>	70 W + 70 W (D.H.T. 0,05% à 8 ohms)
<b>Bande passante</b>	10 Hz — 30 kHz (Puissance 1/2 RMS, D.H.T. 0,05% à 8 ohms.)
<b>Courbe de fréquence</b>	10 Hz—30 kHz ( $\pm 2$ dB)

<b>Distorsion harmonique (à la puissance réelle)</b>	Inférieure à 0,05%
<b>(à la moitié de la puissance réelle)</b>	Inférieure à 0,03%
<b>Distorsion d'intermodulation (à la puissance réelle)</b>	0,05%
<b>(à la moitié de la puissance réelle)</b>	0,03%
<b>Sensibilité d'entrée (à 35 W, 1 kHz de sortie)</b>	
<b>PHONO</b>	3 mV (50 k ohms)
<b>TAPE-1</b>	150 mV (60 k ohms)
<b>TAPE-2</b>	150 mV (60 k ohms)
<b>Niveau d'entrée maximum (PHONO)</b>	140 mV (avec une D.H.T. de 0,1% à 1 kHz)
<b>Niveau de sortie TAPE OUT</b>	150 mV (PHONO, à l'entrée nominale) 150 mV (FM 400 Hz, 30% d'entrée dev: 1 mV) 150 mV (AM 400 Hz, 30% d'entrée mod.: 5 mV/m)
<b>Rapport signal/bruit (IHF, réseau A, puissance nominale)</b>	
<b>PHONO</b>	70 dB
<b>TAPE</b>	90 dB
<b>Facteur d'atténuation Compensateur</b>	40 (1 kHz, 8 ohms)
<b>Commande des graves</b>	RIAA $\pm 0,5$ dB
<b>Commande des aigües</b>	$\pm 10$ dB (50 Hz)
<b>Correction sonore physiologique</b>	$\pm 10$ dB (10 kHz)
<b>Filtre subsonique (-12 dB/oct)</b>	+9 dB (100 Hz), +4 dB (10 kHz) -3 dB (20 Hz) -15 dB (10 Hz)
<b>Témoin de puissance à 10 diodes</b>	Incorporé (gauche et droite)
<b>Mode FM</b>	FM AUTO — MONO
<b>Sonorité FM</b>	Incorporé
<b>Contrôle de bande</b>	2
<b>Indicateur de syntonisation</b>	2 (Signal, syntonisation)
<b>Interrupteur d'enceintes</b>	A, B, A + B
<b>Sortie C.A.</b>	1 (200 W non commutable) (Pour les U.S.A. le Canada et autres pays)
<b>Alimentation</b>	Secteur 120 V C.A. 60 Hz ~120 V/220 V/240 V 50/60 Hz
<b>Consommation</b>	195 W (120 V), 330 W (220/240 V)
<b>Dimensions</b>	453 (W) x 144 (H) x 350 (D) mm
<b>Poids</b>	8 kg

Les caractéristiques techniques et la présentation peuvent être modifiées sans préavis pour des raisons d'améliorations.

# DISASSEMBLY AND REPLACEMENT · ZERLEGUNG UND AUSTAUSCH · DEMONTAGE ET REMONTAGE

- Removing the cover, escutcheon & bottom plate
- Ausbau der Abdeckung, der Schildanbringung und der Bodenplatte
- Déposer le couvercle, le cache-entrée et la plaque inférieure

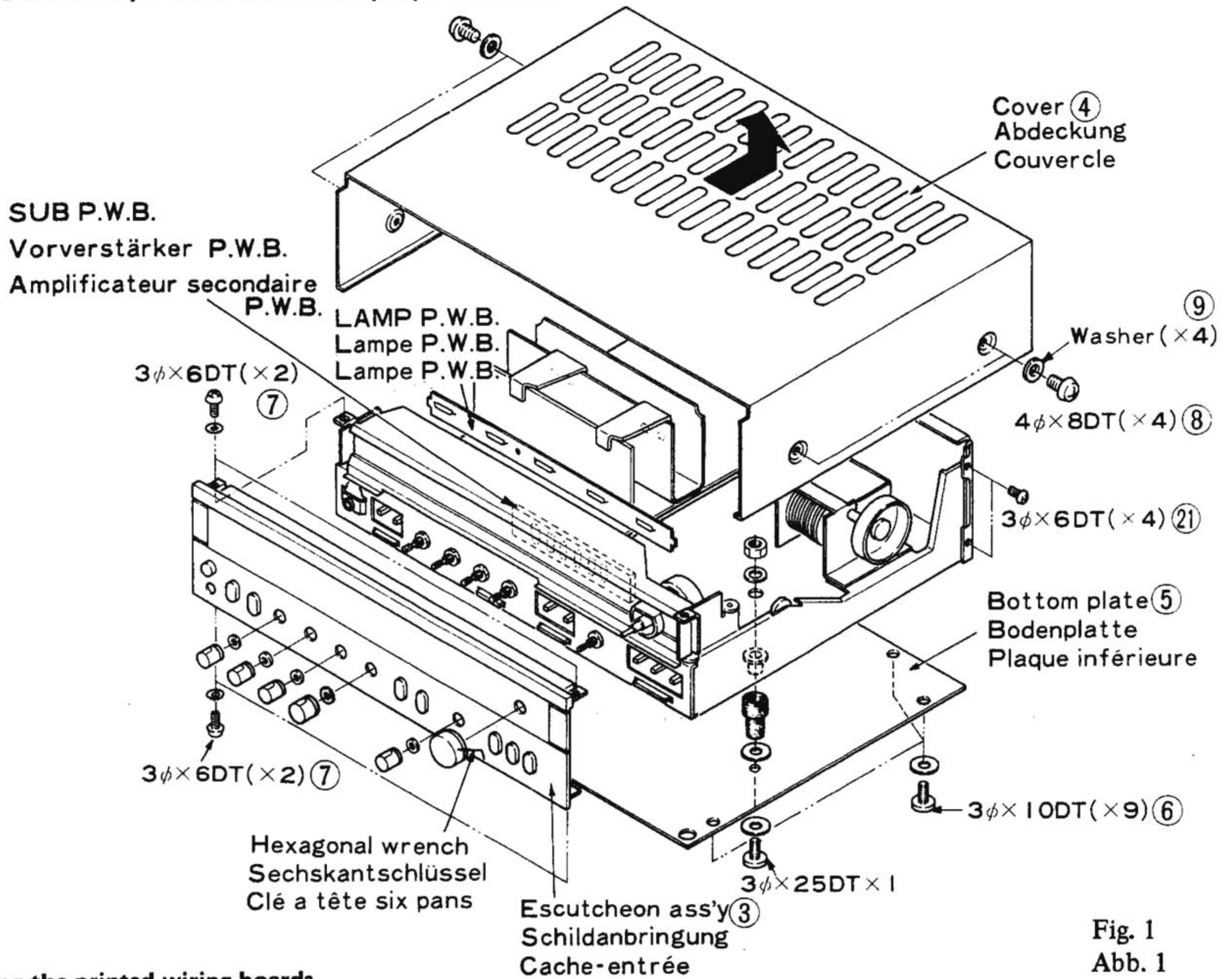

Fig. 1  
Abb. 1

- Removing the printed wiring boards
- Ausbau der Leiterplatten
- Déposer des plaquettes à circuit imprimé

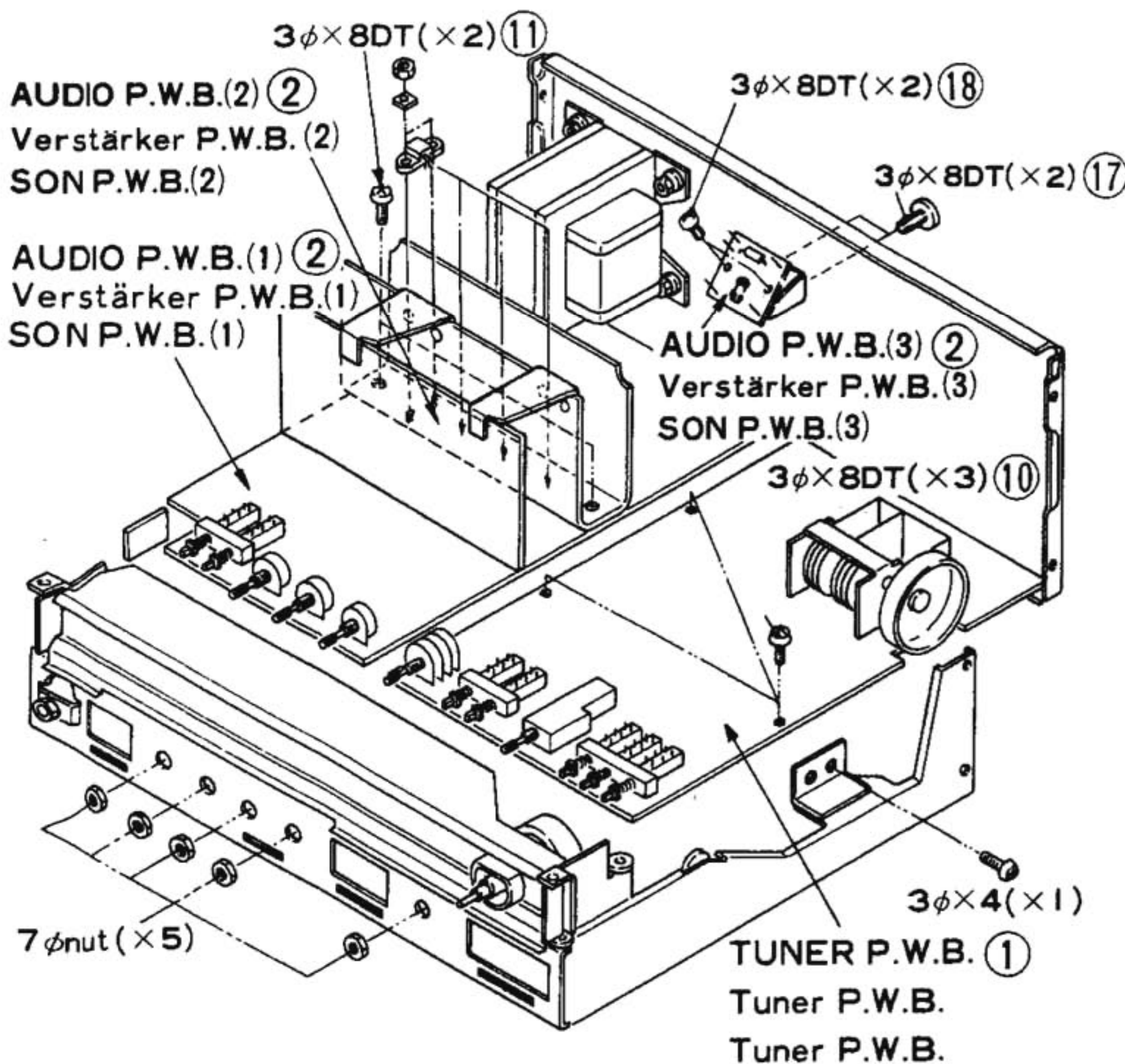

Fig. 2  
Abb. 2

The numbers in the circle marks in the diagram correspond to those in the replacement parts list.  
Die Ziffern in den Kreismarkierungen des Diagramms entsprechen denen in der Ersatzteilliste.  
Les numéros encadrés sur le schéma correspondent à ceux de pièces de remplacement.

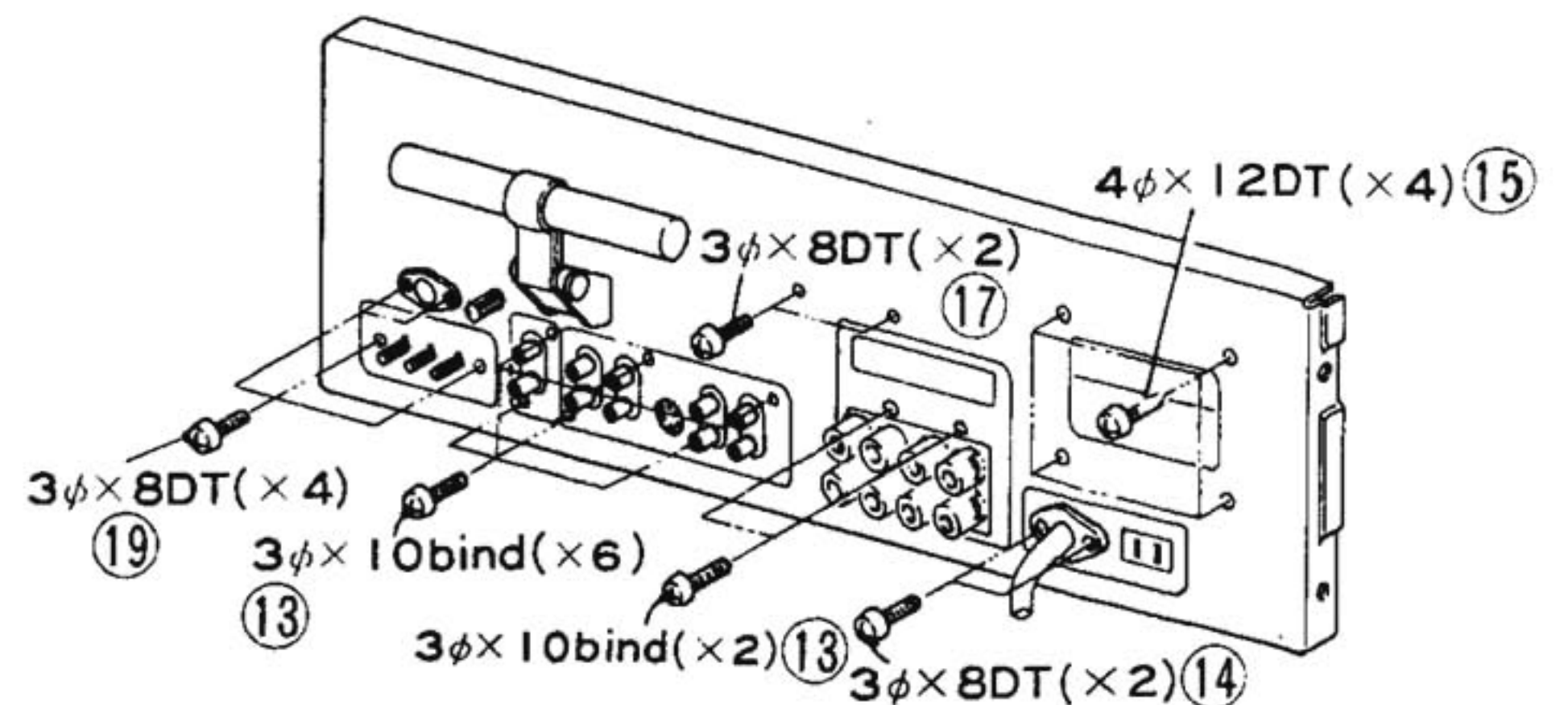

Fig. 3  
Abb. 3

- Removing the power transistors
- Ausbau der Leistungstransistoren
- Retier les transistors de puissance

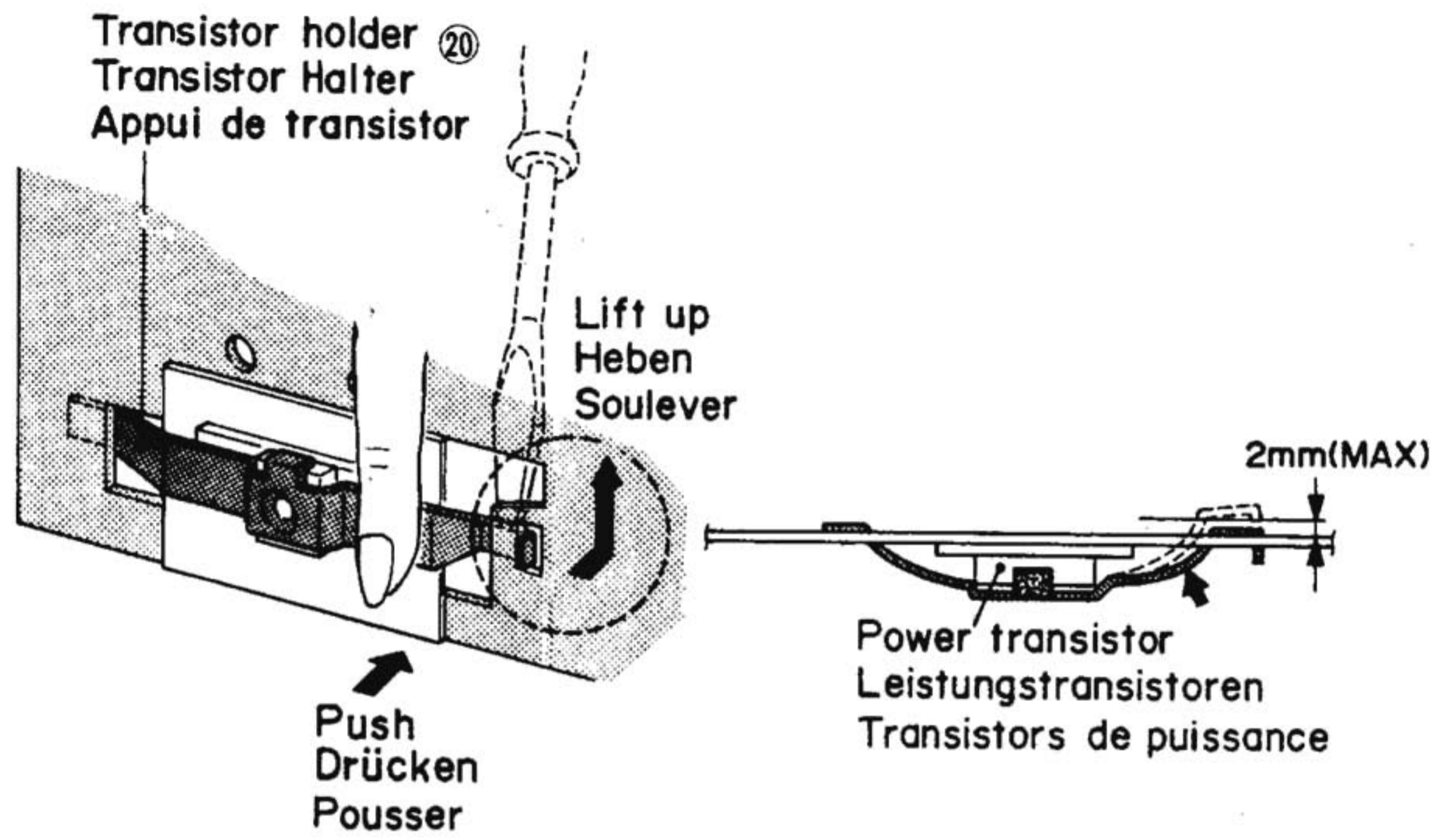

Fig. 4  
 Abb. 4

**DIAL CORD SETTING · SKALENSEILEINSTELLUNG · EQUIPEMENT DE CADRAN**

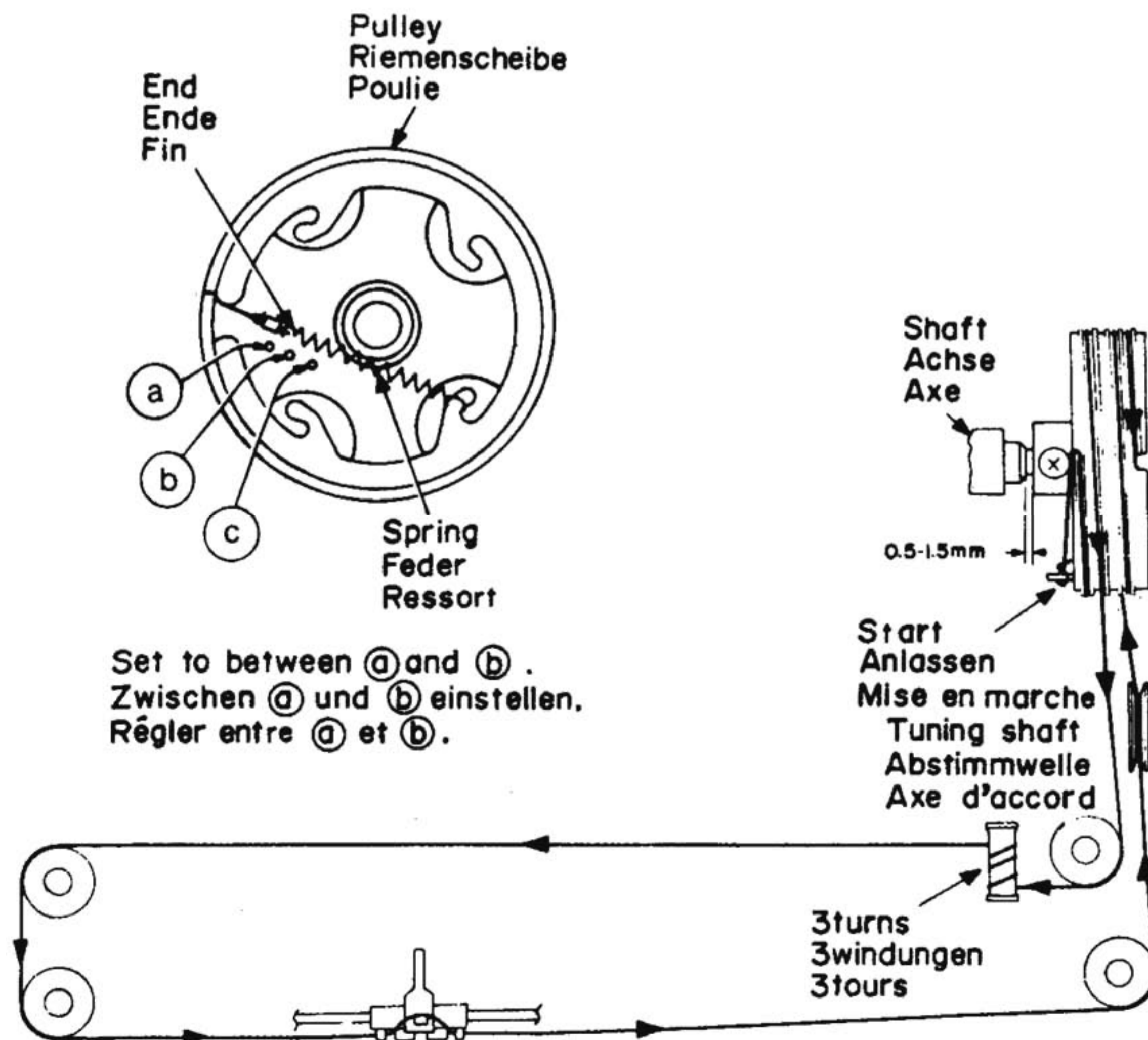

Fig. 5  
 Abb. 5

# GENERAL ALIGNMENT INSTRUCTION · ALLGEMEINE AUSRICHTANLEITUNG · INSTRUCTION GENERALE FM TUNER ALIGNMENT · ABGLEICH DES UKW-TUNERS · REGLAGE DU CIRCUIT SON

Function :	FM	FM Muting :	OFF
Volume :	Minimum		
Modulation:	400Hz 100%		
	(unless otherwise notified)		
Condition	Funktion : UKW	UKW-Stummabstimmung:	Aus
Kondition	Lautstärke: Minimum		
Conditions	Modulation: 400Hz .100%		
	(wenn nicht anderes angegeben)		
Fonction :	FM	Reglage silencieux FM :	OFF
Volume :	au minimum		
Modulation:	400Hz 100%(a moins qu'il en soit specifie autrement).		

- |  |  |   |  |
|--|--|---|--|
| ⊕ Sweep Generator<br>Wobbelgenerator<br>Générateur de balayage | ⊕ Signal Generator<br>Signalgenerator<br>Générateur de signaux | ⊖ Oscilloscope                                  | ⊕ DC Balance Meter<br>Gleichspannungsmesser<br>Indicateur d'équilibrage à C.C. |
| ⊕ VTVM<br>Voltmetre électronique                               | ⊕ Frequency Counter<br>Frequenzzähler<br>Frequencemètre        | ⊕ Dist. Meter<br>Klirrmesser<br>Distorsionmètre |  |

Sequence Folge Ordre	Connection Anschlüsse Connexion		Setting Einstellung Montage		Adjust for Einstellung für Reglage pour		
	Input Eingang Entrée	Output Ausgang Sortie	Tuning Abstimmanzeige Indicateur d'accord	Signal	Adjust Einstellpunkt Reglage	Indication Indikation Indication	
1		in Eingang Entrée TP. 2 100K 0.1u		10.7MHz	T201		
2	out Ausgang Sortie TP. 1 1K	in Eingang Entrée TP. 3 100K 0.1u		10.7MHz	T202 lower : "S" curve upper : Straight line Unten : S-Kurve Oben : Gerade linie inferieure : courbe "S" superieure : ligne droite	Straight line Gerad linie Ligne droite 	
3	ANT. Terminal Antenne Klemme Borne d'antenne	REC out or SP out REC-oder Lautsprecher -Ausgang	87.5MHz	87.5MHz	L102	V max.	
4		Sortie d'enregistrement ou sortie haut-parleur	108MHz	108MHz	CT103	Repeat 3 Schritte 3 Repéter 3	
4			90MHz	90MHz	T101, 102	V max.	
5			106MHz	106MHz	CT101, 102	Repeat 4 Schritte 4 Repéter 4	
5		REC out or SP out REC-oder Lautsprecher- Ausgang	98MHz	98MHz	T202 (lower) (Unten) (inférieure)	- + ⊕ : 0V without signal ohne Signal sans signal	
6	400Hz 30% Mod. Aussteuerung Modulation	Sortie d'enregistrement ou sortie haut-parleur		98MHz	98MHz	T202 (upper) (ober) (supérieure)	Distortion min. CAUTION (1) Verzerrungen minimal Vorsicht (1) Distorsion minimum ATTENTION (1)
7		REC out REC-Ausgang					
8	Non-modulated Nicht moduliert Sans modulation	Sortie d'enregistrement		98MHz	98MHz	R313	76kHz ±100Hz
9	Rech 400Hz 46% Mod. Rechter Kanal, 400Hz, 46% Modulation	REC out or SP out REC-oder Lautsprecher- Ausgang					
	Canal droit 400Hz, 46% de modulation Piloton, 8% Modulation Signal pilote 8% de modulation	Sortie d'enregistrement L. P. F.					

Tuner P.W.B. · Tuner, gedruckte Schaltung · Plaque imprimée de tuner

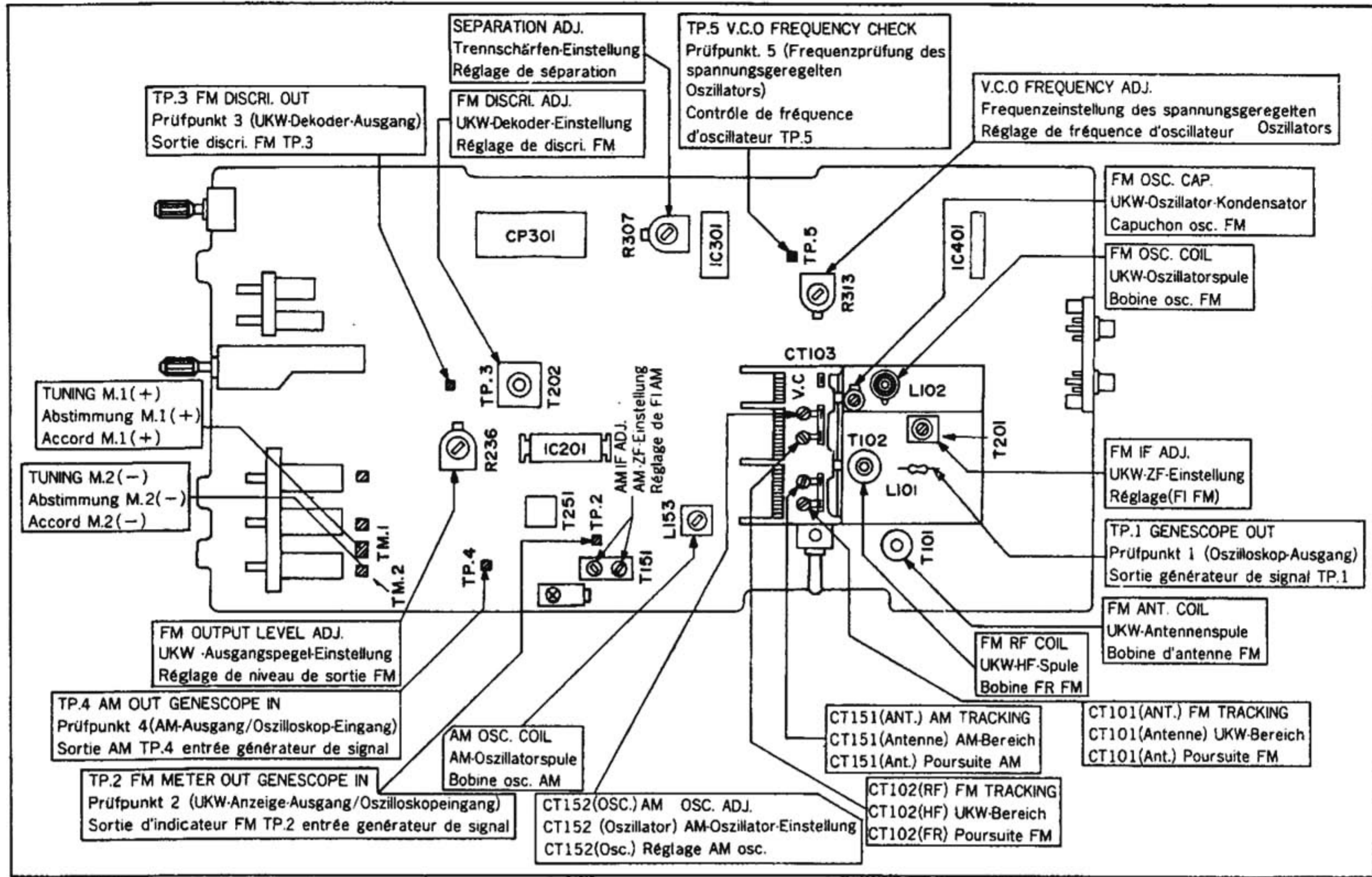

- CAUTION**
1. As the result of the adjustment step 6, the best point of adjustment from step 5 will be shifted a bit, Repeat the adjustment of step 5 and 6 until the deterioration becomes minimum and the DC balance meter shows 0 volt. (Fig. 12)
  2. Optimize R307 so that the leak level of the L ch signal is equal to that of the R ch signal.

- VORSICHT**
1. Aufgrund der in Schritt 6 beschriebenen Einstellung kann sich der in Schritt 5 beschriebene, optimale Einstellpunkt um etwas verschieben. Die Einstellungen der Schritte 5 und 6 daher mehrmals wiederholen, bis minimale Abweichung gewährleistet ist und der Gleichspannungsmesser zeigt 0 V an. (Abb. 12)
  2. R307 so einjustieren, daß der Übersprechpegel des linken gleich dem des rechten Kanalsignales ist.

- ATTENTION**
1. A la suite du réglage décrite en 6, le meilleur réglage décrit en 5 sera légèrement décalé. Renouveler les réglages 5 et 6 jusqu'à ce que les détériorations soient minimum et l'indicateur d'équilibre à C.C. indique 0 V. (Fig. 12)
  2. Rendre R307 optimum pour que le niveau de crête du signal de canal gauche (L) soit égal à celui du canal droit (R).

AM TUNER ALIGNMENT · ABGLEICH DES AM TUNER · REGLAGE DU TUNER AM

Condition                      Function: AM  
 Kondition                     Funktion: AM                      Modulation: 400Hz 30%  
 Conditions                    Fonction: AM

Sequence Folge Ordre	Connection Anschlüsse Connexion		Setting Einstellung Montage		Adjust for Einstellung für Réglage pour	
	Input Eingang Entrée	Output Ausgang Sortie	Tuning Abstimmanzeige Indicateur d'accord	Signal	Adjust Einstellpunkt Réglage	Indication Indikation Indication
1	out Ausgang Sortie  1K CT151	in Eingang entrée  TP. 4 100K 0.1μ		455kHz	T151	 CAUTION (1) VORSICHT (1) ATTENTION (1)
2	Ferrite Antenna Ferritkernantenne Antenne en ferrite	REC out or SP out Sortie d'enregistrement ou sortie haut-parleur		600kHz 1400kHz	600kHz 1400kHz	L153 CT152
3				600kHz 1400kHz	600kHz 1400kHz	L152 Ferrite Antenna Ferritkernantenne Antenne en ferrite  V max. CAUTION (2) VORSICHT (2) ATTENTION (2)



- CAUTION**
- In step 1, set the capacitance of the variable capacitor to minimum and adjust red and blue cores of T151 so that the wave form is as shown in Fig. 6. As T151 contains a 455 kHz ceramic filter, sometimes the center of the marker will not correspond to that of the wave form. In this case, neglect the marker. After adjusting as above, increase the output level of the sweep generator and adjust T151 again so that the top of the wave form A (indicated in Fig. 7) will be flat and wide.
  - In carrying out adjustment described in step 2 and 3, repeat the adjustment so that the output at 600 kHz and 1400 kHz become maximum.



Fig. 6  
Abb. 6

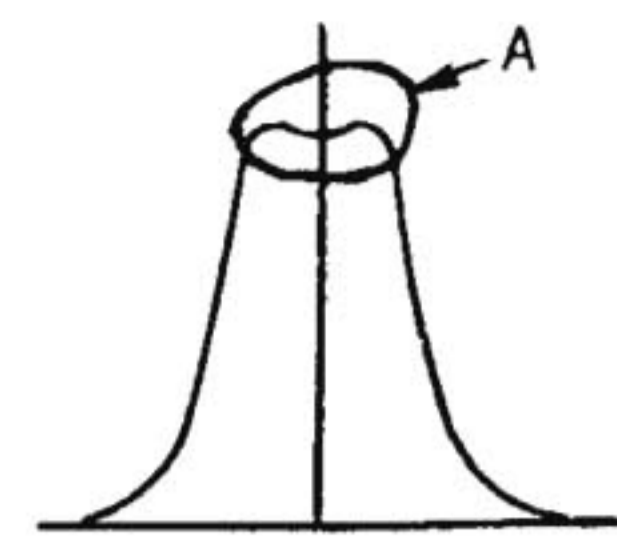

Fig. 7  
Abb. 7

- VORSICHT**
- In Schritt 1 ist die Kapazität des Regelkondensators auf ein Minimum einzustellen; die roten und blauen Kerne von T151 so einzustieren, daß die in Abb. 6. gezeigte Wellenform erhalten wird. Da T151 auch ein 455-kHz-Keramikfilter enthält, kann es vorkommen, das manchmal die Mitte der Anzeige nicht mit der Wellenamplitude übereinstimmt. In diesem Falle ist die Anzeige nicht zu beachten. Nach der obigen Einstellung den Ausgangspegel des Wobbelgenerators erhöhen und T151 nochmals einstellen, so daß der Maximalwert der Welle an Punkt A (gezeigt in Abb. 7) eine Abflachung und Verbreiterung erfährt.
  - Die in den Schritten 2 und 3 aufgeführten Einstellungen durchführen und mehrmals wiederholen, bis der Ausgangspegel eines 600 kHz bzw. 1.400 kHz Signals einen Maximalwert annimmt.

- ATTENTION**
- Dans le point 1, régler la capacitance du condensateur variable sur la position minimum et ajuster les noyaux rouge et bleu de T151 pour que la forme d'onde soit identique à celle indiquée sur l'illustration (Fig. 6). Etant donné que T151 contient un filtre céramique de 455 kHz, il peut arriver que le centre de l'indicateur ne corresponde pas à la forme d'onde. Si le cas se présente, ne pas tenir compte de la position de l'indicateur. Après avoir effectué les réglages cidessus, augmenter le niveau de sortie à l'aide d'un générateur de balayage et ajuster T151 une nouvelle fois pour que le haut de la forme d'onde A (illustrée par la Fig. 7) soit plate et large.
  - En effectuant le réglage décrit en 2 et 3, répéter le réglage pour que la sortie à 600 kHz et 1400 kHz soit maximale.

## AUDIO CIRCUIT ALIGNMENT · ABGLEICH DES AUDIO SCHALTKREISES REGLAGE DU CIRCUIT SON

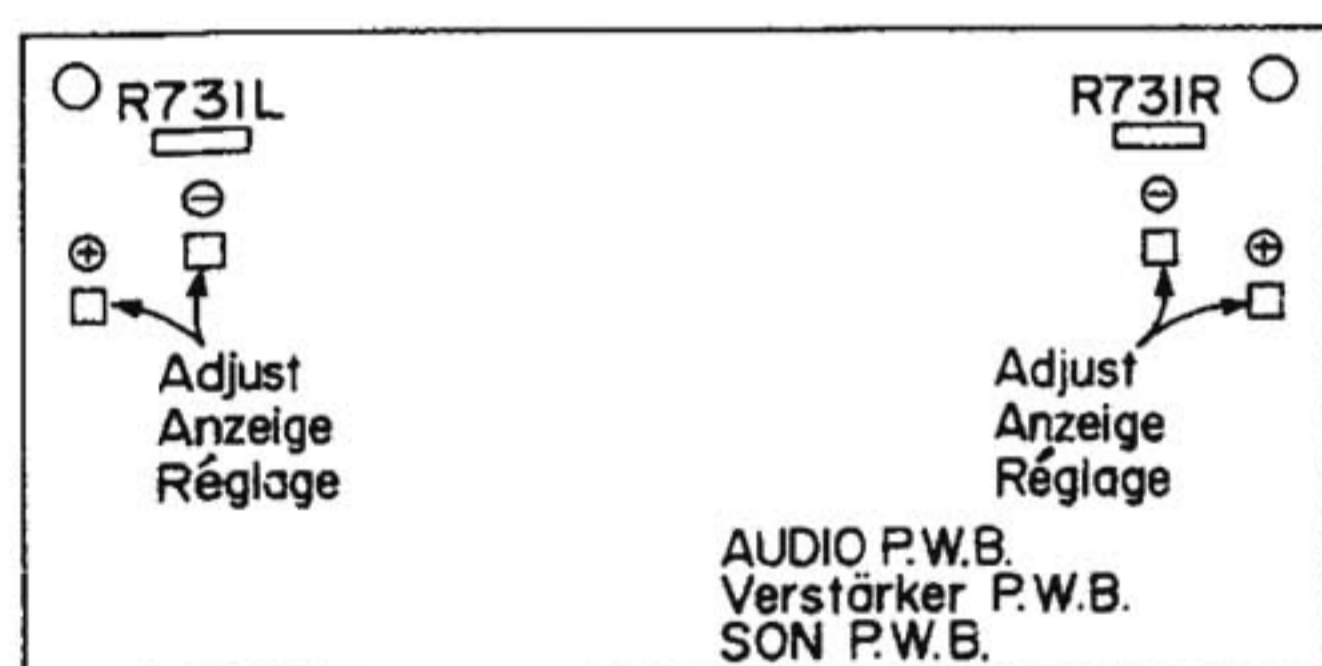

Fig. 8  
Abb. 8

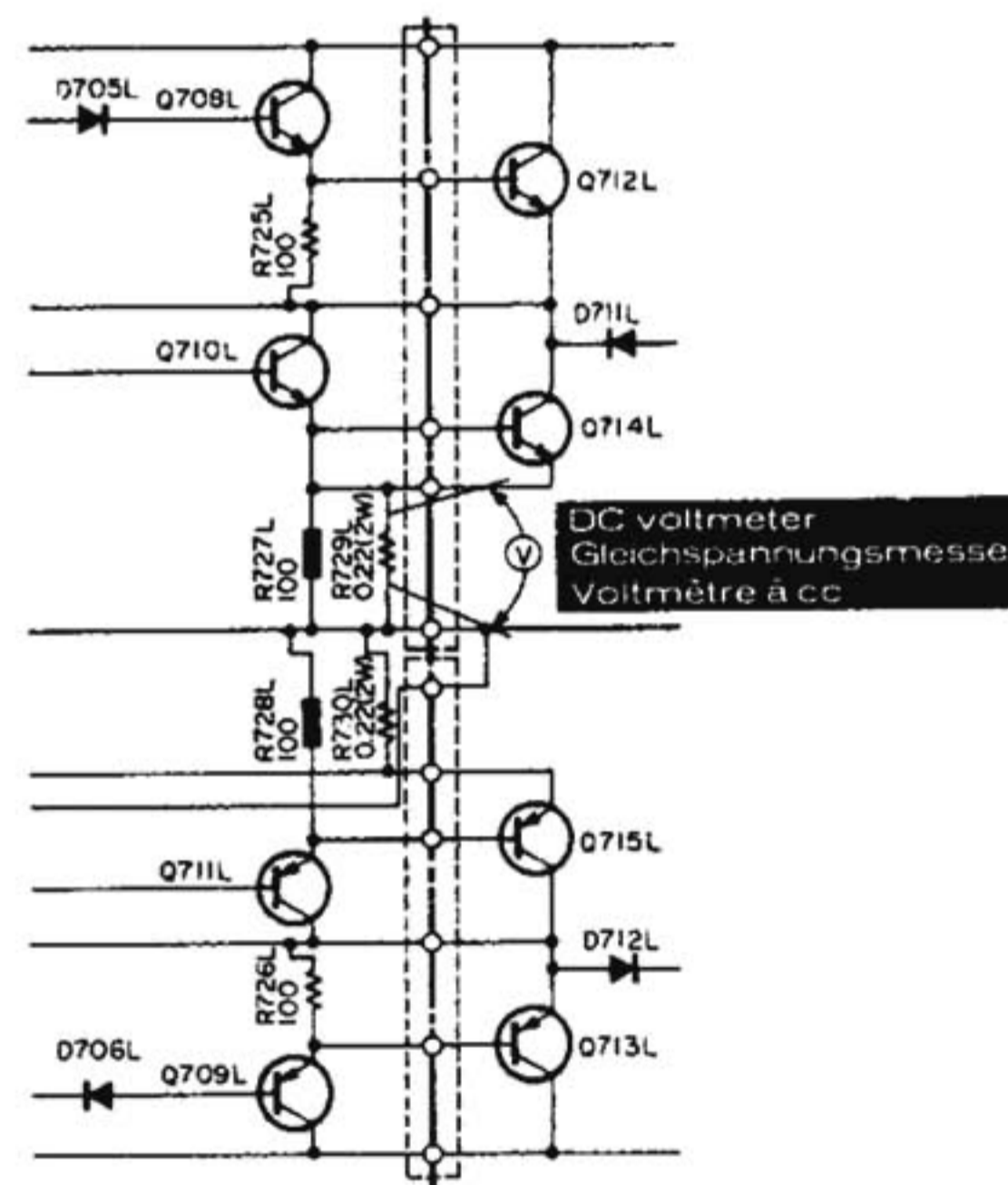

Fig. 9  
Abb. 9

**Test conditions**

FUNCTION . . . . Free      VOLUME . . . . . Minimum

Item	Measuring instrument	Point be measured	Adjust	Value adjusted
Idle current	DC voltmeter	Fig. 8	R731L, R	8.8mV ± 4.4mV (40mA ± 20mA)

**Versuchsbedingungen**

FUNCTION . . . . Frey      VOLUME . . . . . Minimum

Benennung	Meßinstrument	Zu messender Punkt	Anzeige	Valeur Anzeigt
Blindstrom	Gleichspannungsmesser	Abb. 8	R731L, R	8,8mV ± 4,4mV (40mA ± 20mA)

**Conditions pour les essais**

FUNCTION . . . . Libre      VOLUME . . . . . Minimal

Désignation	Appareil de mesure	Point de mesure	Réglage	Valeur ajustée
Courant déwatte	Voltmètre à D.C.	Fig. 8	R731L, R	8,8mV ± 4,4mV (40mA ± 20mA)

Fig. 10 FM IF Discriminator and AM IF alignments  
(FM:Step.1,2;AM:Step.1)

Abb. 10 UKW-ZF-Diskriminator und AM-ZF-Abgleich  
(UWK:Schritte 1,2;AM:Schritt 1)

Fig. 10 Réglages de discriminateur FM IF et AM IF  
(Operations 1,2 FM et : AM)

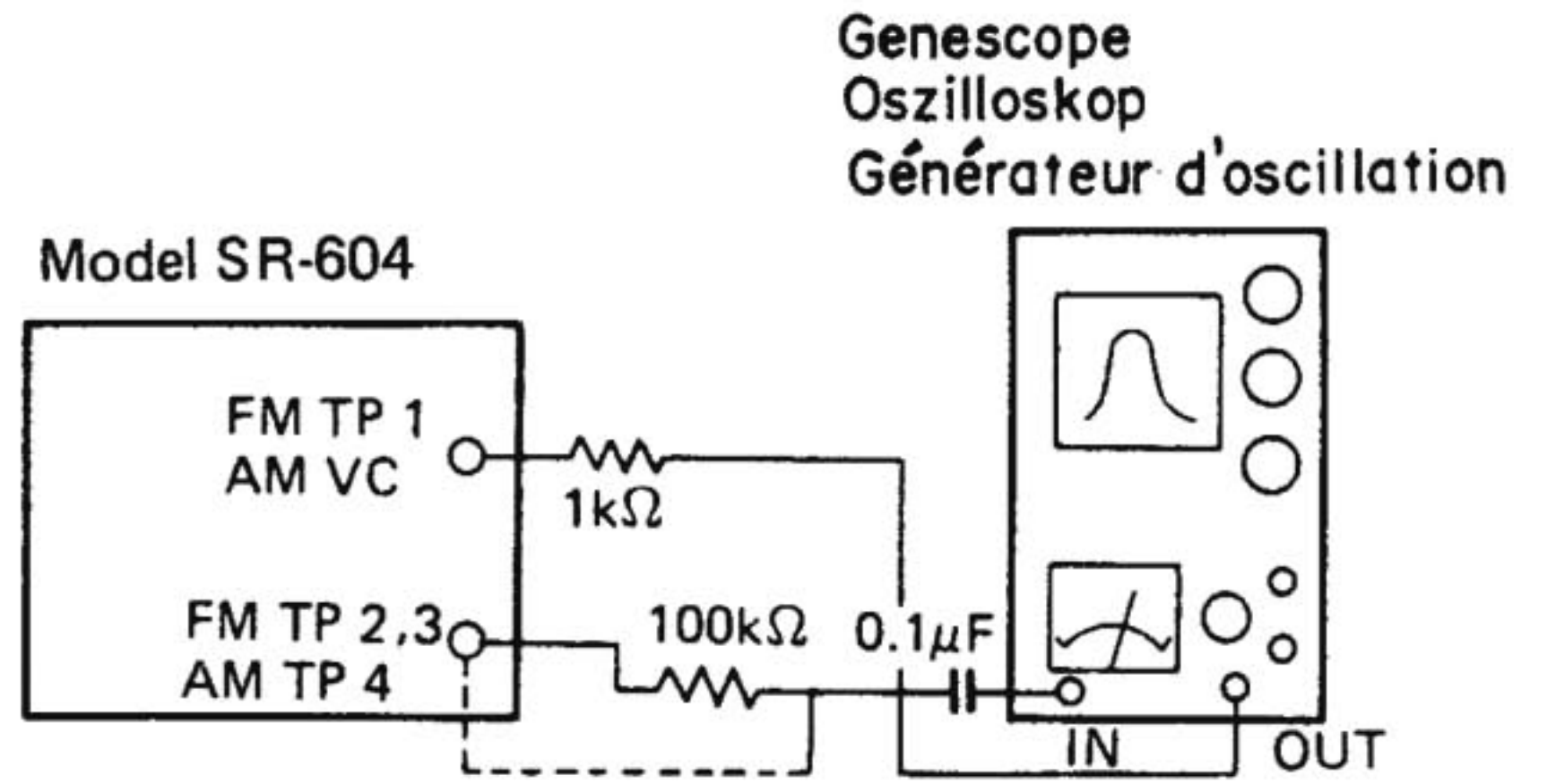

AM Signal generator  
AM Signalgenerator  
Générateur de signal AM

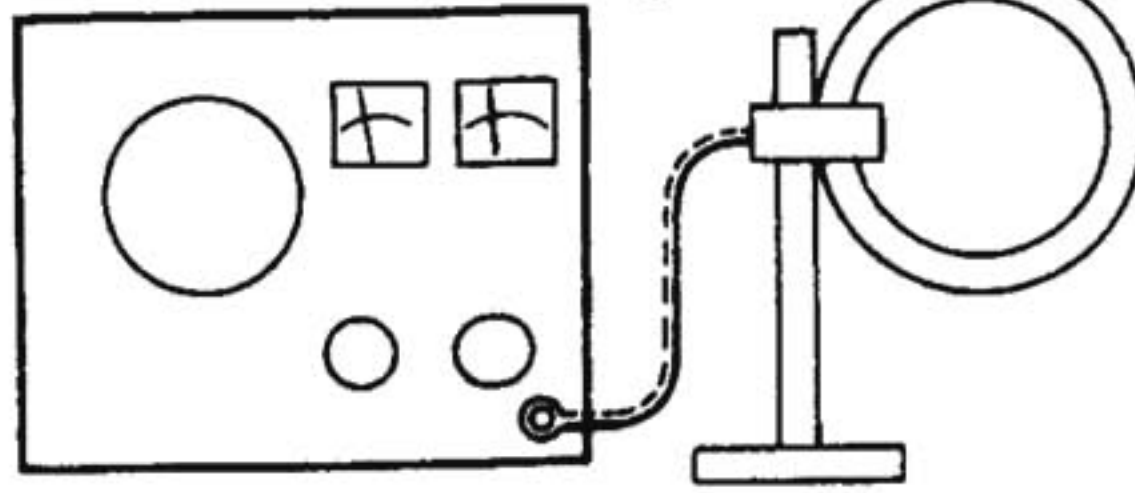

Loop antenna  
Rahmenantenne  
Antenne en boucle

AC Voltmeter  
Wechselspannungsmesser  
Voltmètre à courant alternatif

Oscilloscope

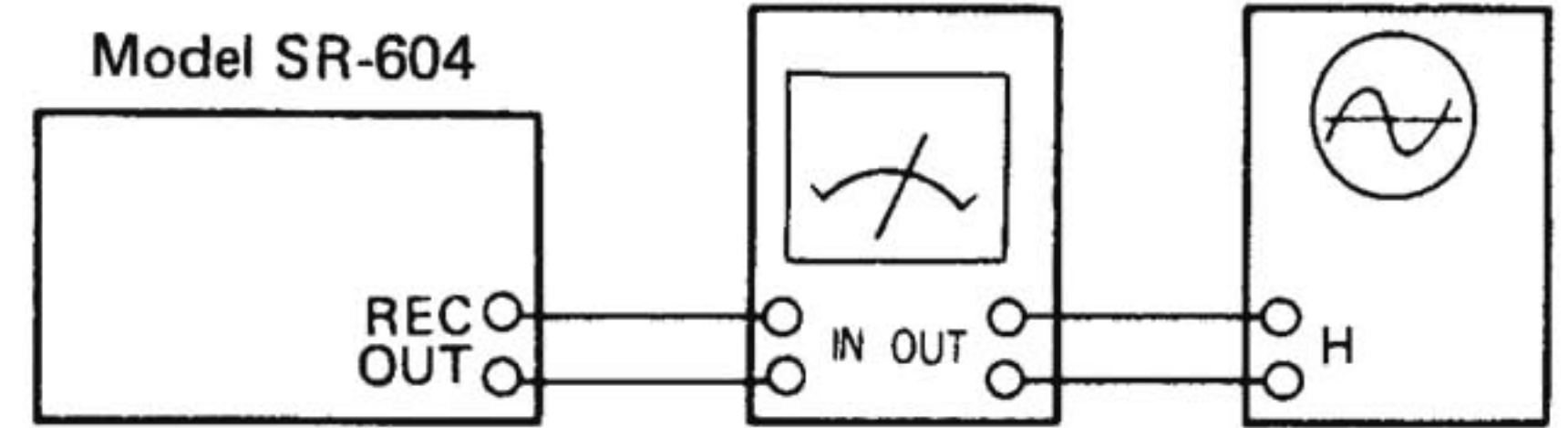
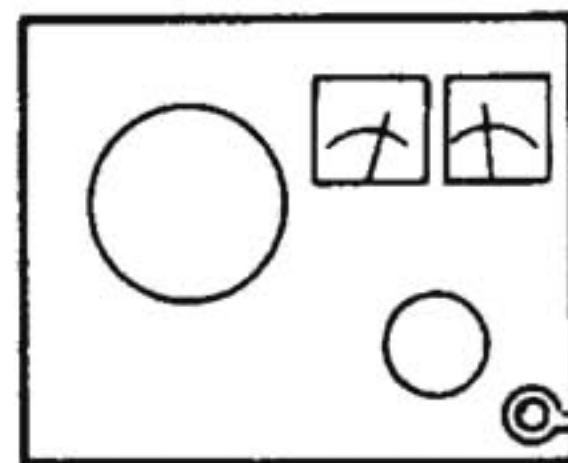

Fig. 11 AM frequency covering and tracking alignments  
(Step.2 and 3)

Abb. 11 AM-Bereich- und Nachführungsabgleich  
(Schritte 2 und 3)

Fig. 11 Réglages de poursuite et d'étendue de fréquence AM  
(Operations 2 et 3)

FM Signal generator  
UKW Signalgenerator  
Générateur de signal FM



ANT. DUMMY  
Kunstantenne  
Antenne fictive

DC Balance Meter  
Gleichspannungsmesser  
Indicateur d'équilibrage à C.C.

Model SR-604



AC Voltmeter  
Wechselspannungsmesser  
Voltmètre à courant alternatif

Oscilloscope

Distortion meter  
Klirrmesser  
Distortiomètre

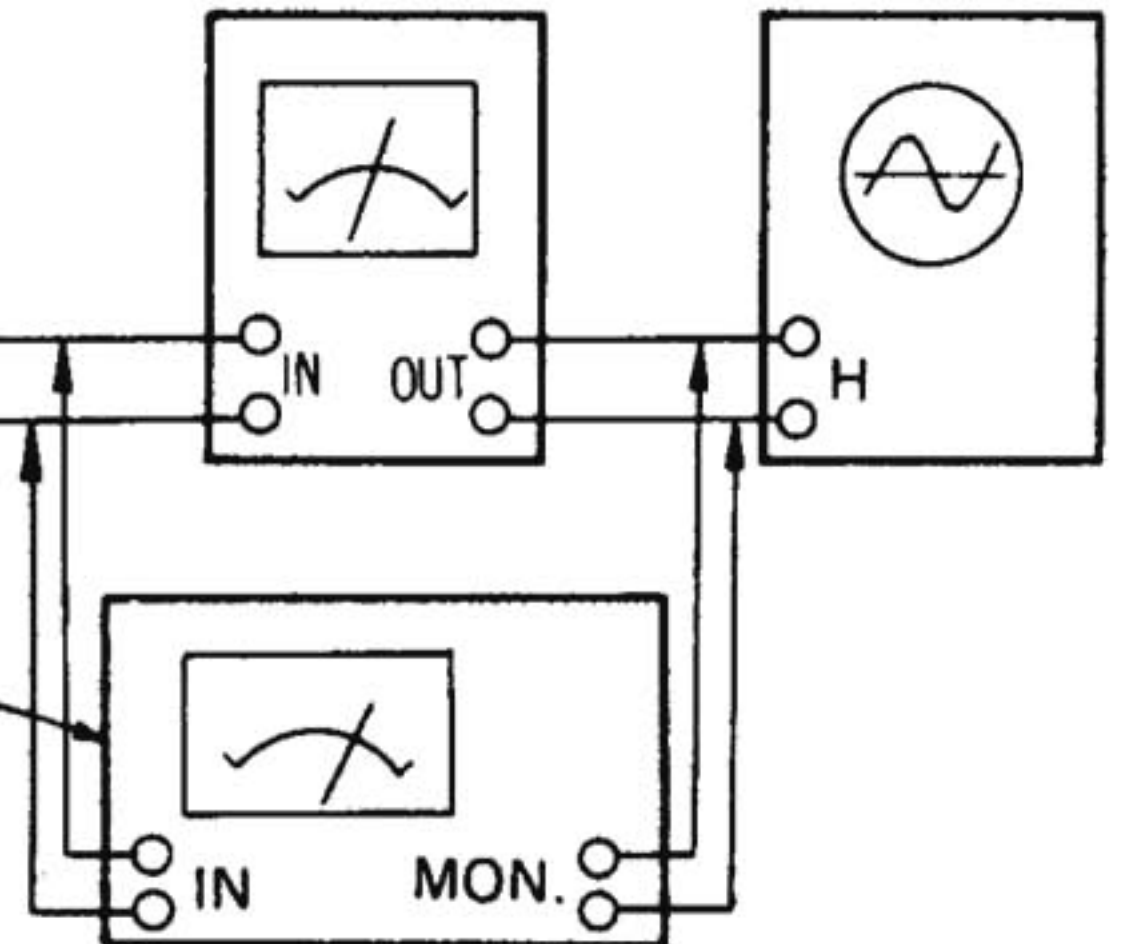

Fig. 12 FM frequency covering, tracking and other alignments (Step.3 to 7)  
Abb. 12 UKW-Bereich-, -Nachführungs- und andere Abgleiche  
(Schritte 3 bis 7)

Fig. 12 Réglages de poursuite, d'étendue de fréquence FM et autres  
(Operations 3 à 7)

Fig. 13 FM MPX 76kHz adjustment  
(Step. 8)

Abb. 13 UKW-Dekoder 76-kHz-Abgleich  
(Schritt 8)

Fig. 13 Réglage de 76kHz MPX FM  
(Operation 8)

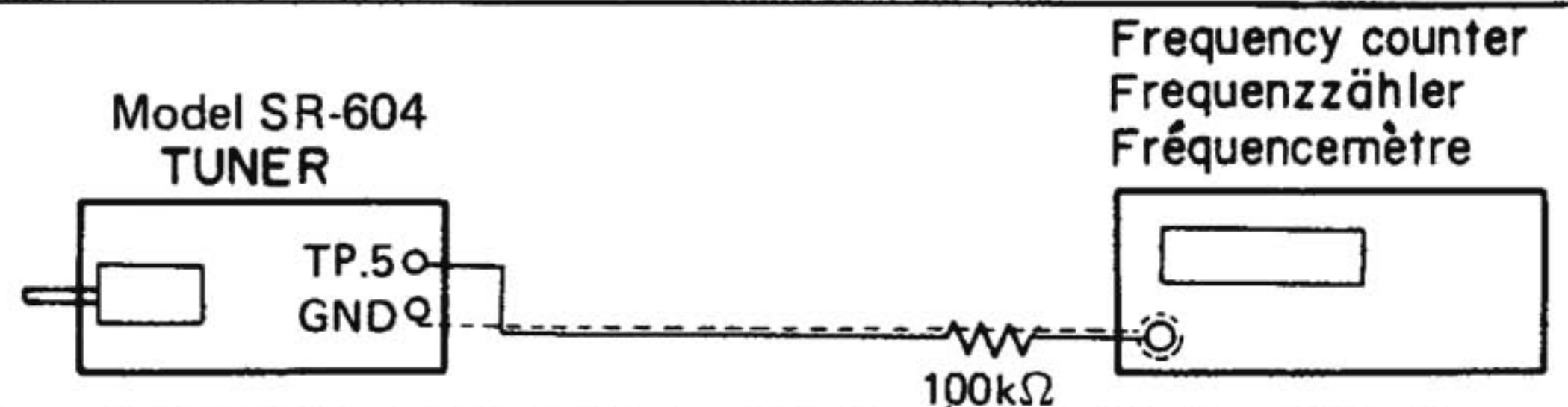

FM Stereo Signal generator  
UKW Stereo signalgenerator  
Générateur de signal stéréo FM

FM Signal generator  
UKW Signalgenerator  
Générateur de signal FM



ANT. DUMMY  
Kunstantenne  
Antenne fictive

Model SR-604



AC Voltmeter  
Wechselspannungsmesser  
Voltmètre à courant alternatif

Oscilloscope

Fig. 14 FM MPX alignments (Step.9)

Abb. 14 UKW-Dekoder-Abgleich (Schritt 9)

Fig. 14 Réglage de MPX FM (Operation 9)

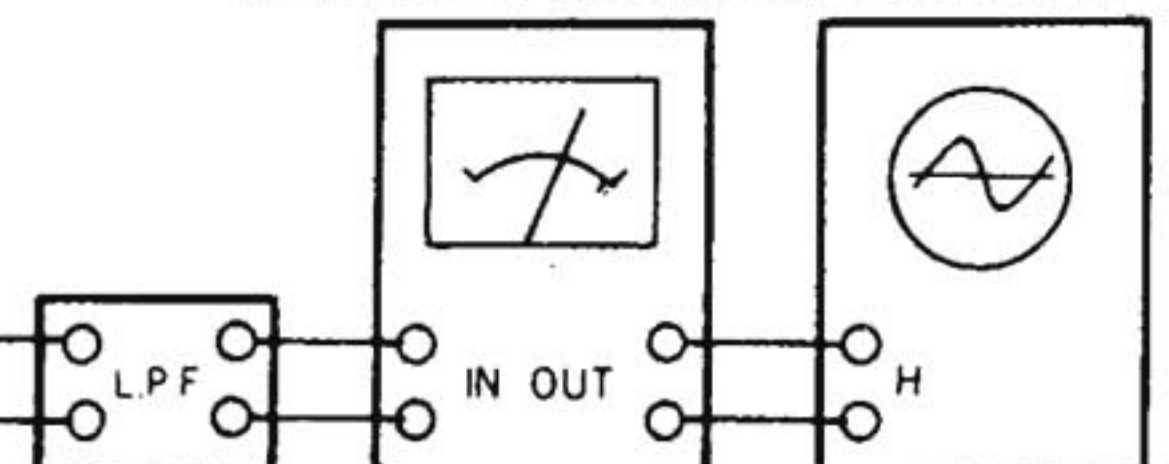

# PRINTED WIRING BOARD · PRINTPLATTEN · PLAN DE BASE

AUDIO · Verstärker · Audio

[ : +B, : -B, : Earth, : Other ]

The circuit symbol ( ) means a fuse resistor. When replacing it with new one, refer to the CAUTION on page 13.  
 Das Schaltsymbol ( ) steht für Schmelzwiderstand. Beim Austausch bitte Seite 13 ZUR BEACHTUNG nachlesen.  
 Le symbole de circuit ( ) signifie qu'il s'agit d'une résistance à fusible. Consulter les instructions "ATTENTION" de la page 13 pour effectuer son remplacement.



3SK45	2SC535 2SC454 2SC461 2SC458	2SC2389 2SA1038 2SD756 2SB716	2SC1740LN 2SB647 2SD667	2SB616 2SD586	2SD478	1S2076 AW08-13 HZ-12 HZ-16 IN34A	S4VB20	LED	U06C	MV-5W

The terminal No. shows the stamp on the printed wiring board. This number matches the number in the circuit diagram.

Die Anschlussklemmen sind auf der gedruckten Schaltung nummeriert. Die Nummern stimmen mit den Nummern im Schaltplan überein.

Le N° de borne correspond à l'indication de la plaquette à circuit imprimé. Ce numéro correspond au numéro du schéma de montage.

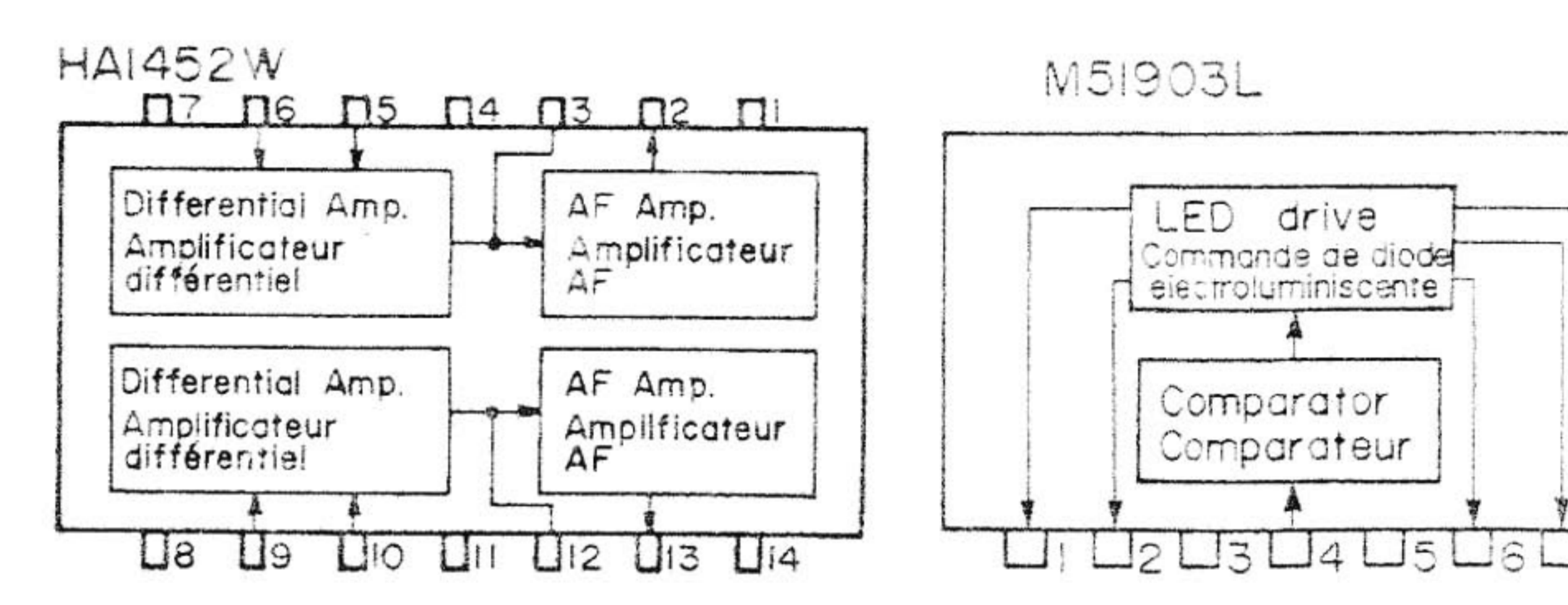
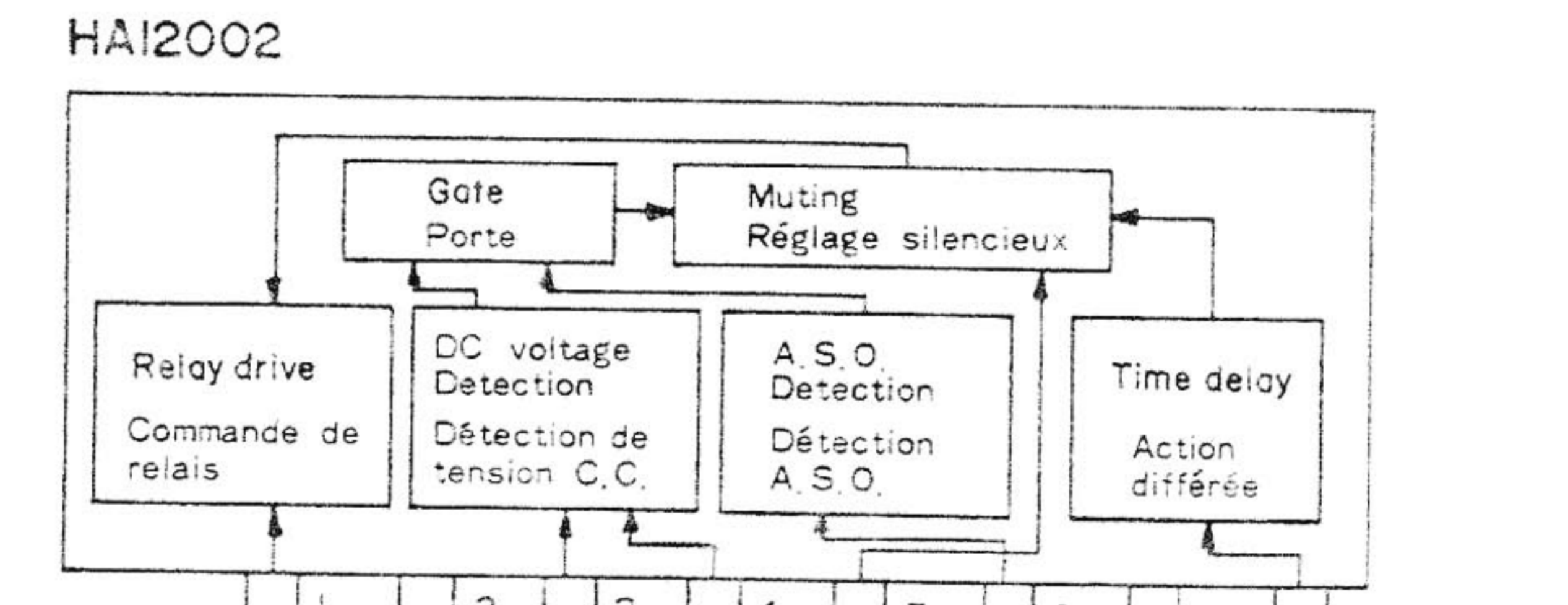
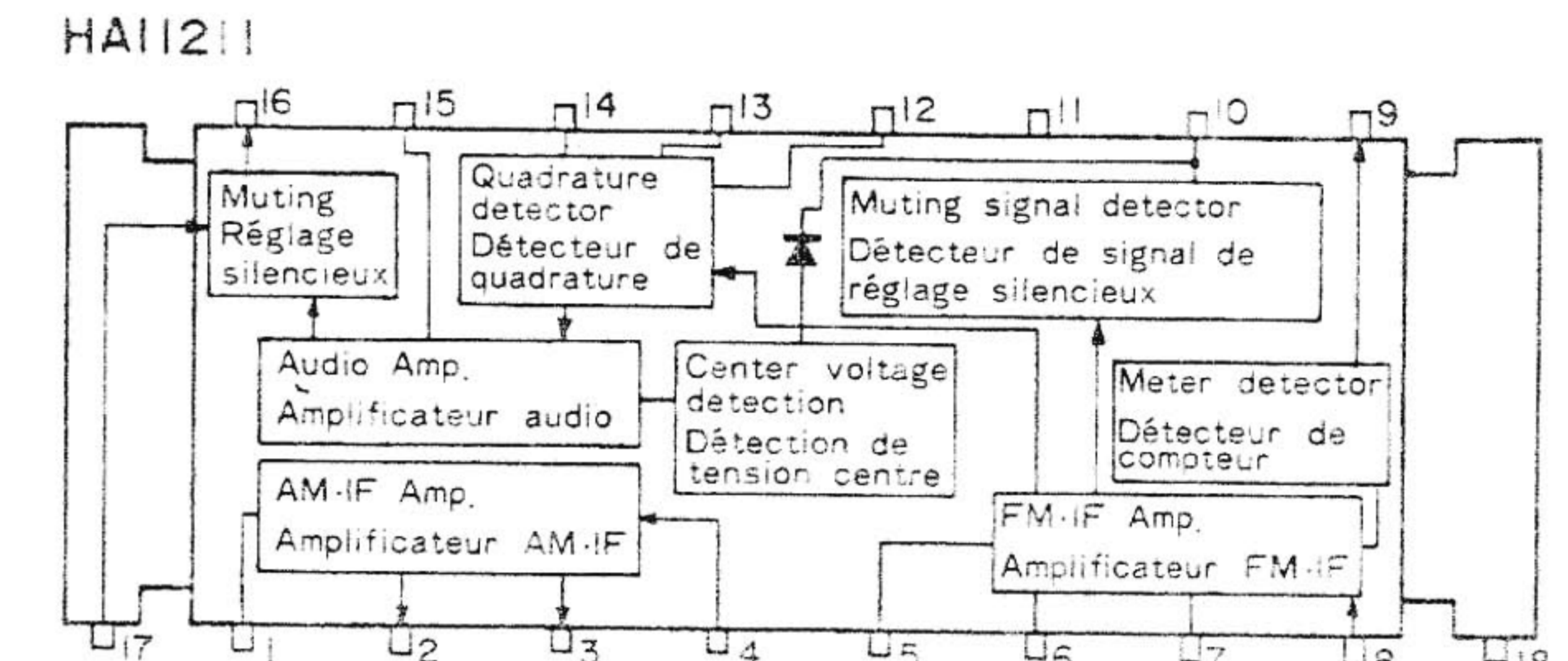
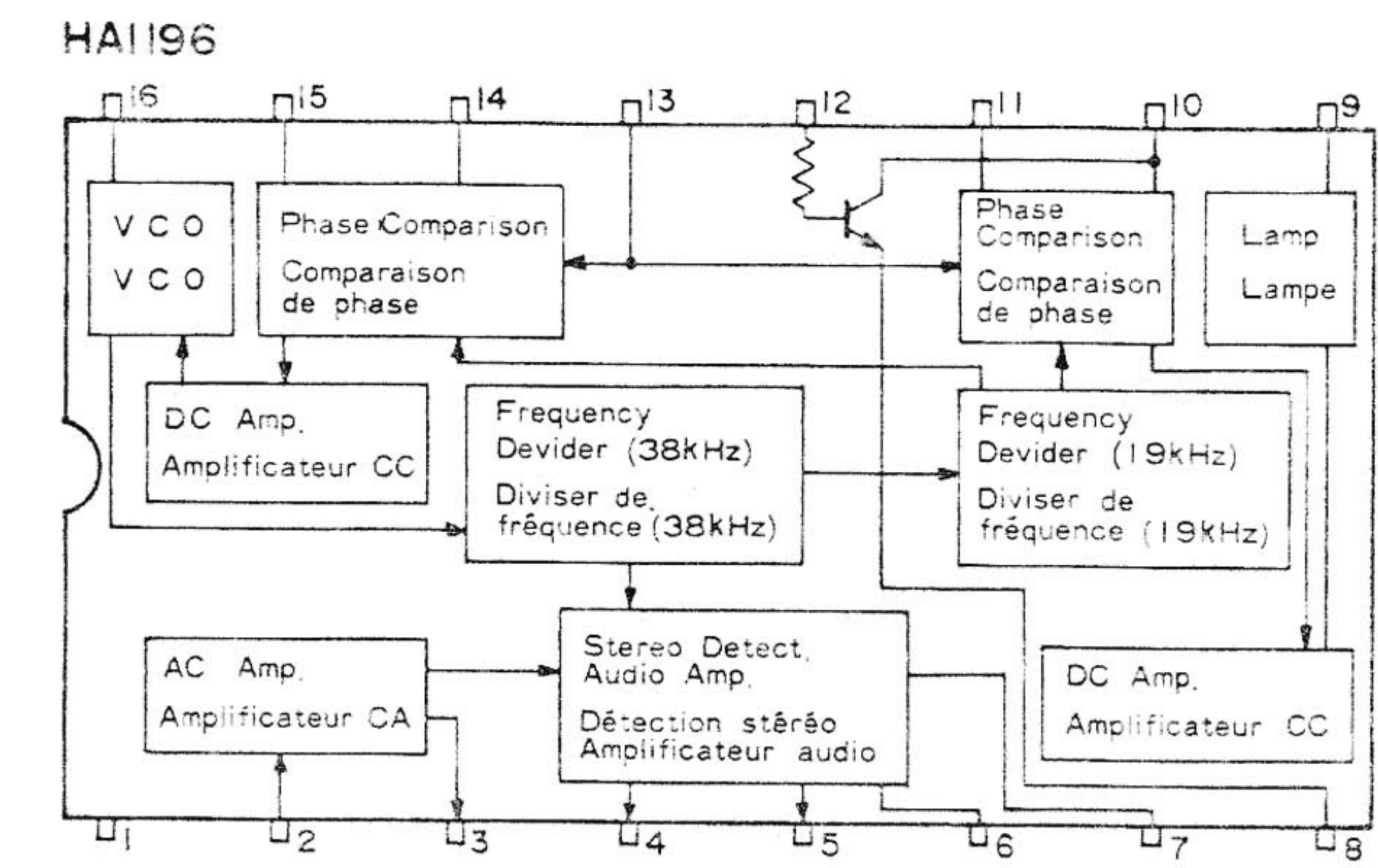
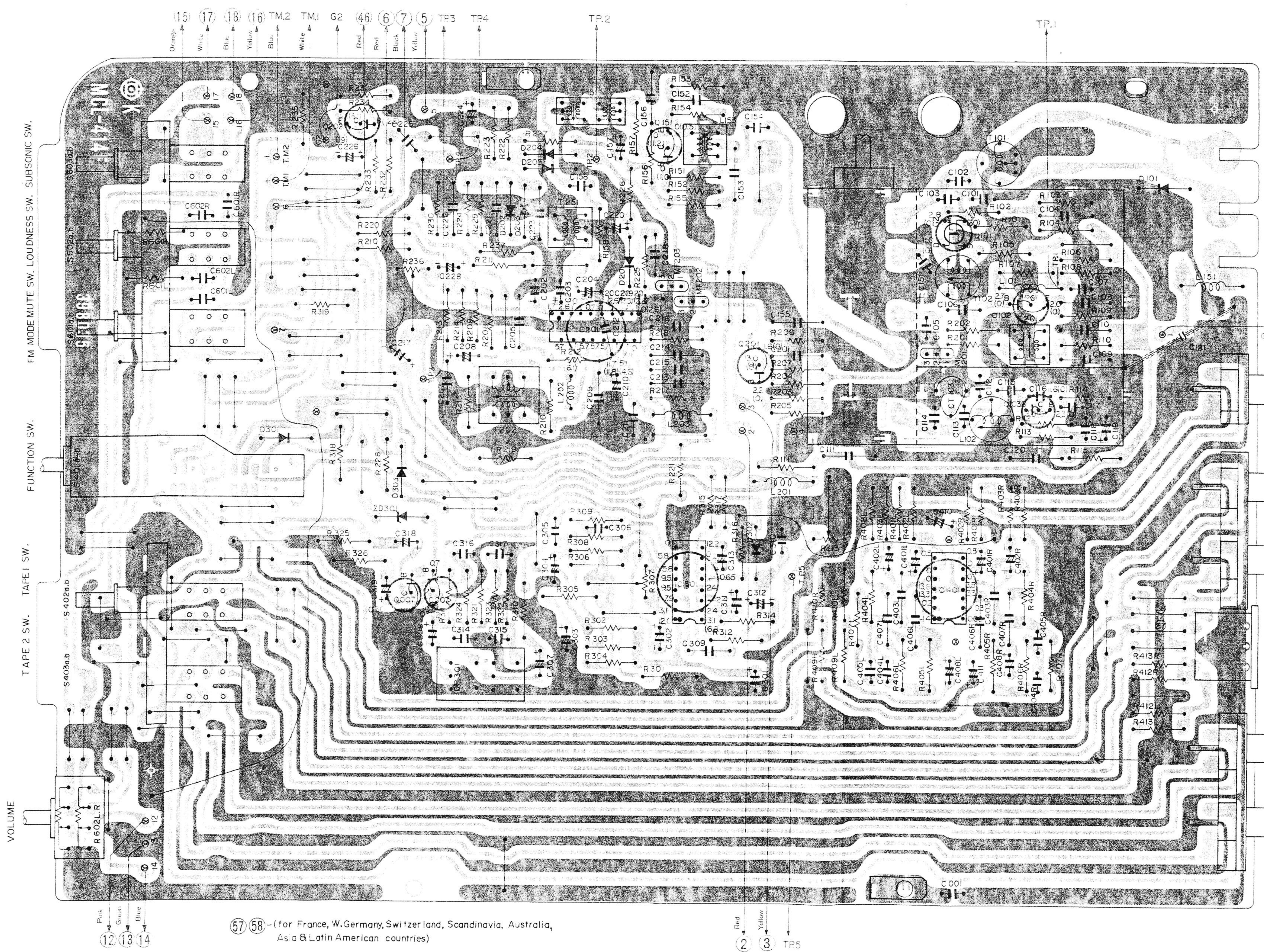

CAUTION (For Asia & Latin American countries only)  
 The power supply voltage of this set can be changed by the VOLTAGE SELECTER. If you want to change-over the set voltage from 220V or 240V to 120V, the primary fuse must also be changed. See table of following figure.

	FUSE (FOG 1)	Position of Voltage selector	Connection of Primary circuit
AC 120V	T3.15A 250V	120V	—
~ 220V	T1.6A 250V	220V or 240V	(A)
~ 240V	T1.6A 250V	220V or 240V	(B)

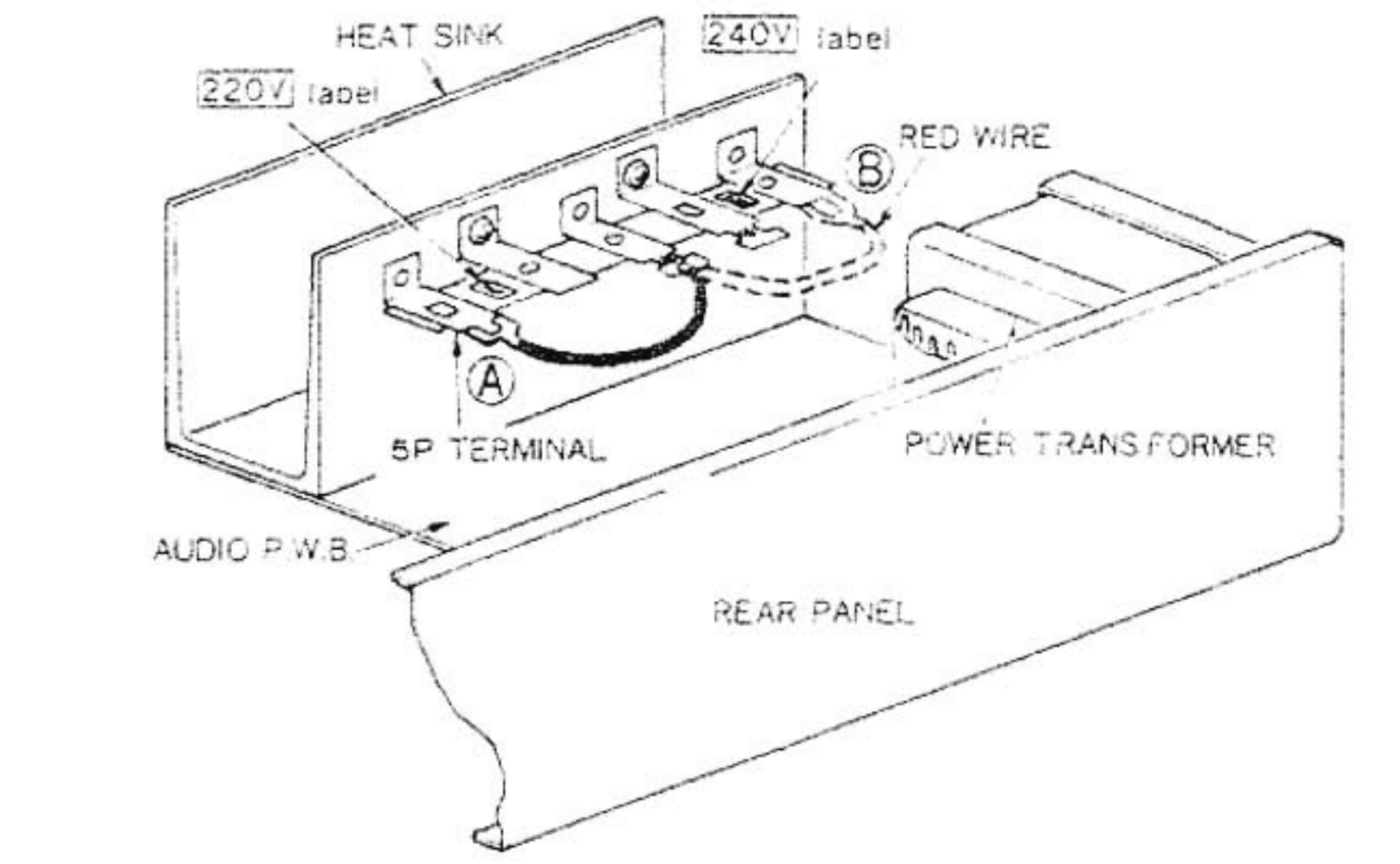

The terminal No. shows the stamp on the printed wiring board. This number matches the number in the circuit diagram.

Die Anschlussklemmen sind auf der gedruckten Schaltung numeriert. Die Nummern stimmen mit den Nummern im Schaltplan überein.

Le N° de borne correspond à l'indication de la plaquette à circuit imprimé. Ce numéro correspond au numéro du schéma de montage.

# CIRCUIT DIAGRAM · SCHALTPLAN · PLAN DE CIRCUIT

**PRODUCT SAFETY NOTE:** Components marked with a  $\Delta$  have special characteristics important to safety.  
**SICHERHEITSHINWEIS:** Die mit  $\Delta$  gekennzeichneten Komponenten haben wichtige Sicherheitsaufgaben.  
**NOTICE DE SECURITE DE FABRICATION:** Les composants qui sont accompagnés du symbole  $\Delta$  possèdent des caractéristiques spéciales.



BLOCK DIAGRAM · BLOCK SCHEMA · SCHEMA

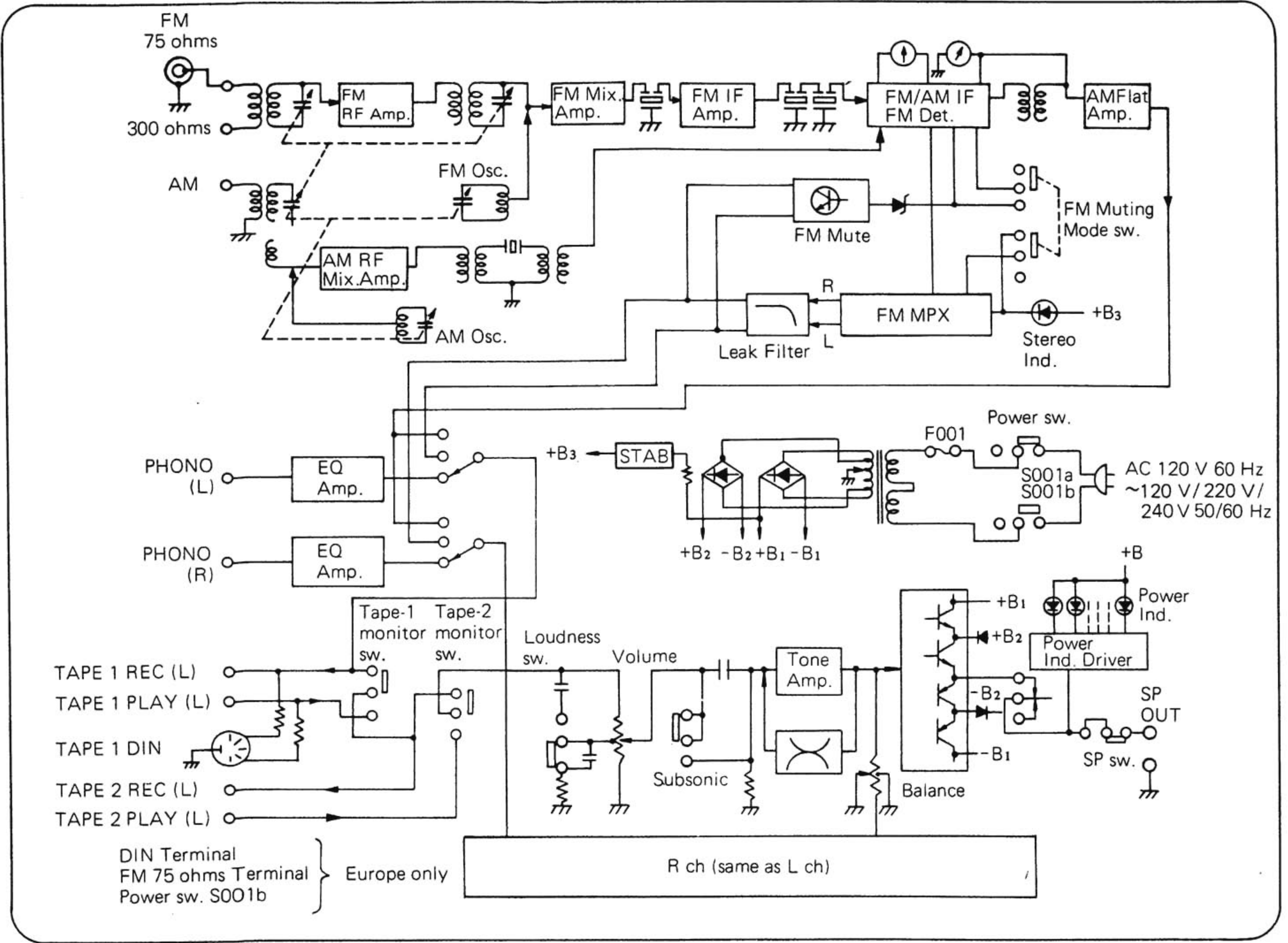

# PRINTED WIRING BOARD · PRINTPLATTEN · PLAN DE BASE

SUB · Vorverstärker · Amplificateur secondaire [  : +B,  : Earth,  : Other ]

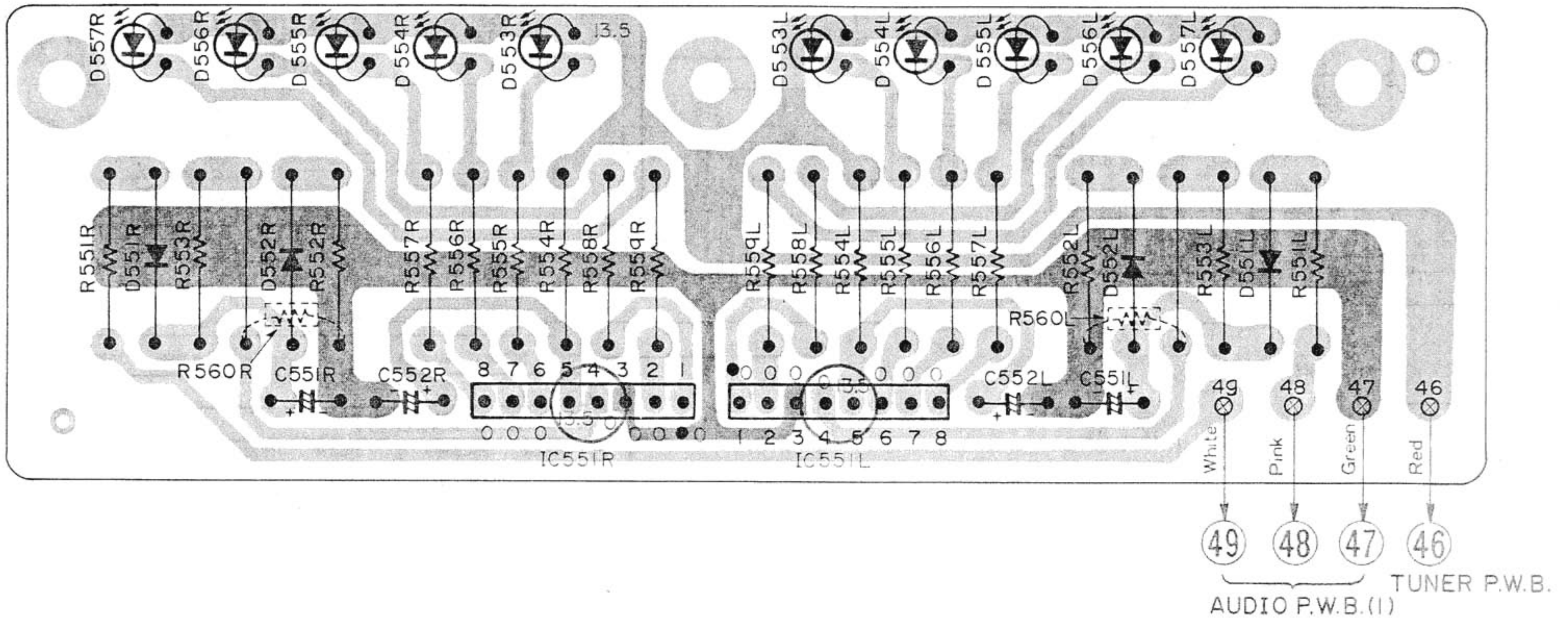

## PRIMARY CIRCUIT DIAGRAM (FOR ASIA & LATIN AMERICAN COUNTRIES)

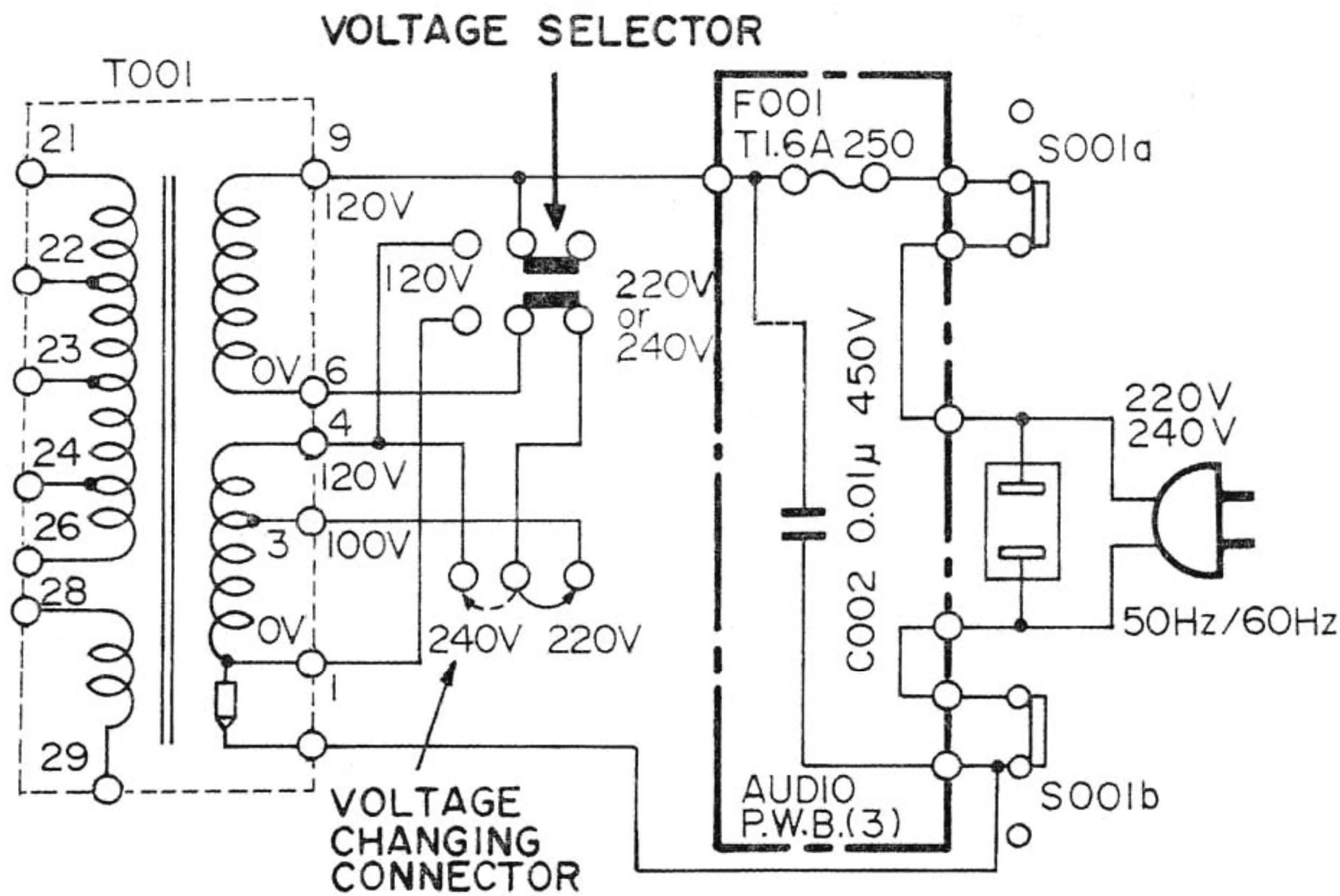

Volt	FUSE (FOO1)
AC120V	T3.15A 250V
AC220/240V	T1.6A 250V

# FRONT AND REAR PANEL · VORDERE UND HINTERE BEDIENUNGS TAFEL · PANNEAUX AVANT ET ARRIERE

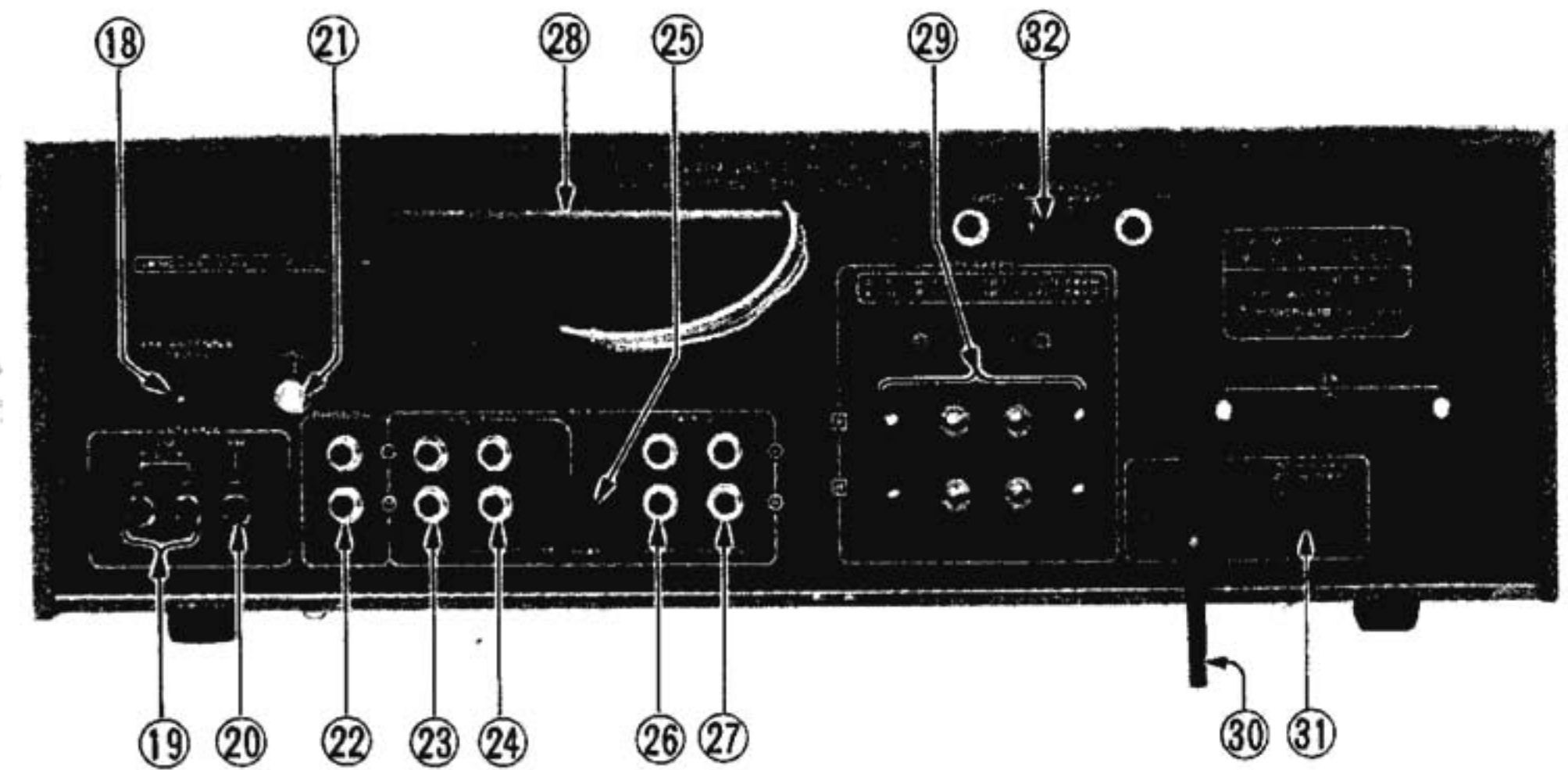
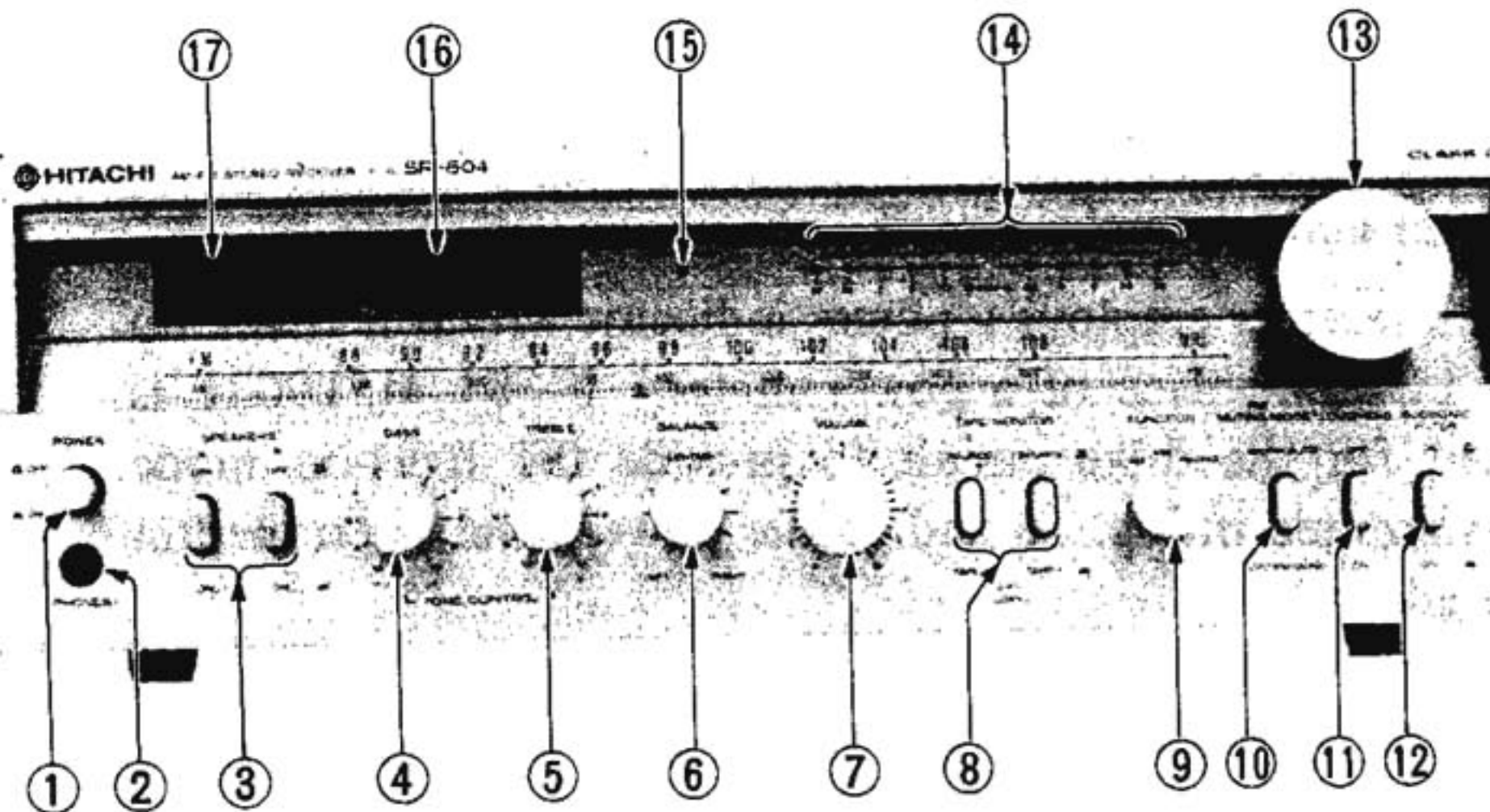

- ① POWER switch
- ② PHONES jack
- ③ SPEAKERS switches (A, B)
- ④ BASS control
- ⑤ TREBLE control
- ⑥ BALANCE control
- ⑦ VOLUME control
- ⑧ TAPE MONITOR switches
- ⑨ FUNCTION switch
- ⑩ FM MUTING/MODE switch
- ⑪ LOUDNESS switch
- ⑫ SUBSONIC FILTER switch
- ⑬ Tuning knob
- ⑭ POWER LEVEL indicators
- ⑮ FM STEREO indicator
- ⑯ TUNING meter
- ⑰ SIGNAL meter
- ⑱ FM ANTENNA socket (75 ohms)  
(Except for U.S.A. & Canada set)
- ⑲ FM ANTENNA terminals (300 ohms)
- ⑳ AM ANTENNA terminal
- ㉑ Ground terminal (GND)
- ㉒ PHONO input terminals
- ㉓ TAPE-1 PLAY terminals
- ㉔ TAPE-1 REC OUT terminals
- ㉕ TAPE-1 DIN REC/PLAY socket  
(Except for U.S.A. & Canada set)
- ㉖ TAPE-2 PLAY terminals
- ㉗ TAPE-2 REC OUT terminals
- ㉘ AM bar antenna
- ㉙ SPEAKERS terminals
- ㉚ AC line cord
- ㉛ AC outlet  
(For U.S.A., Canada, Asia & Latin  
American countries)
- ㉜ VOLTAGE SELECTOR  
(For Asia & Latin American countries)

- ① Netzschalter (POWER)
- ② Kopfhörerbuchse (PHONES)
- ③ Lautsprecherschalter (SPEAKERS) (A, B)
- ④ BASS-Regler
- ⑤ Höhenregler (TREBLE)
- ⑥ BALANCE-Regler
- ⑦ Lautstärkereglern (VOLUME)
- ⑧ Schalter für Hinterbandkontrolle  
(TAPE MONITOR)
- ⑨ Funktionsschalter (FUNCTION)
- ⑩ UKW-Stillabstimmung (FM MUTING)/  
Betriebsarten (MODE)-Schalter
- ⑪ Schalter für gehörriichtige Lautstärkekontur  
(LOUDNESS)
- ⑫ Unterfrequenzfilter-Schalter  
(SUBSONIC FILTER)
- ⑬ Abstimmknopf
- ⑭ Leistungspegel-Anzeigen (POWER LEVEL)
- ⑮ UKW-STEREO-Anzeige
- ⑯ Abstimmanzeige (TUNING)
- ⑰ Feldstärke-Meßinstrument (SIGNAL)
- ⑱ UKW-Antennenklemme (75 Ohm)  
(Außer U.S.A. und Kanada-Modell)
- ⑲ UKW-Antennenklemme (300 Ohm)  
(FM ANTENNA)
- ⑳ MW-Antennenklemme  
(AM ANTENNA)
- ㉑ Erdungsklemme (GND)
- ㉒ Plattenspieler-Eingangsbuchse (PHONO)
- ㉓ Eingang für Tonbandgerät 1  
(TAPE-1 PLAY)
- ㉔ Ausgang für Tonbandgerät 1  
(TAPE-1 REC OUT)
- ㉕ DIN-Normbuchse  
(TAPE-1 DIN REC/PLAY)  
(Außer U.S.A. und Kanada-Modell)
- ㉖ Eingang für Tonbandgerät 2  
(TAPE-2 PLAY)
- ㉗ Ausgang für Tonbandgerät 2  
(TAPE-2 REC OUT)
- ㉘ MW-Ferritstabantenne
- ㉙ Lautsprecher-Klemmen (SPEAKERS)
- ㉚ Wechselstrom-Netzkabel
- ㉛ Wechselstromausgang  
(Für U.S.A., Kanada, Asien und Südamerika)
- ㉜ Netzspannungswähler  
(VOLTAGE SELEKTOR)  
(Für Asien und Südamerika)

- ① Interrupteur d'alimentation (POWER)
- ② Casque stéréophonique (PHONES)
- ③ Commutateurs d'enceintes (A, B)  
(SPEAKERS)
- ④ Commande de graves (BASS)
- ⑤ Commande d'aiguës (TREBLE)
- ⑥ Commande d'équilibrage (BALANCE)
- ⑦ Commande de VOLUME
- ⑧ Interrupteurs de contrôle de bande  
(TAPE MONITOR)
- ⑨ Commutateur de fonction (FUNCTION)
- ⑩ Commutateur de soudrine FM  
(FM MUTING/MODE)
- ⑪ Commutateur de correction physiologique  
(LOUDNESS)
- ⑫ Commutateur de filtre subsonique  
(SUBSONIC FILTER)
- ⑬ Bouton d'accord
- ⑭ Témoins de niveau de puissance  
(POWER LEVEL)
- ⑮ Indicateur FM STEREO
- ⑯ Indicateur d'accord FM (TUNING)
- ⑰ Indicateur de SIGNAL
- ⑱ Prise d'antenne FM (75 ohms)  
(FM ANTENNA)  
(Sauf appareil pour U.S.A. et Canada)
- ⑲ Bornes d'antenne FM (300 ohms)  
(FM ANTENNA)
- ⑳ Borne d'antenne AM (AM ANTENNA)
- ㉑ Prise de terre (GND)
- ㉒ Bornes d'entrée PHONO
- ㉓ Bornes de reproduction de bande 1  
(TAPE-1 PLAY)
- ㉔ Bornes d'enregistrement de bande 1  
(TAPE-1 REC OUT)
- ㉕ Prise DIN de bande 1  
(TAPE-1 DIN REC/PLAY)  
(Sauf appareil pour U.S.A. et Canada)
- ㉖ Borne de reproduction de bande 2  
(TAPE-2 PLAY)
- ㉗ Borne d'enregistrement de bande 2  
(TAPE-2 REC OUT)
- ㉘ Antenne de ferrite AM
- ㉙ Bornes d'enceintes (SPEAKERS)
- ㉚ Cordon d'alimentation CA
- ㉛ Sortie CA (Pour les U.S.A., le Canada,  
l'Asie et l'Amérique du Sud)
- ㉜ Sélecteur de tension  
(VOLTAGE SELECTOR)  
(Pour l'Asie et l'Amérique du Sud)



## DESCRIPTION OF THE NEW CIRCUIT

### Dynaharmony (Class G Amplifier) output circuit

The level of the music source changes momentarily, the percentage of high level (over 1/2 of peak value) is very small, it is only less than 2% of the total music signals. Large output amplifiers have been used conventionally to playback at high levels without distortion; however, in this case, high voltage is impressed to the output transistor, so the power consumption is large.

Studies have been made, how to obtain high output powers without the increase of the output transistors' consumption in order to improve the efficiency. Thus, the new dynaharmony output circuit (Class G Amplifier) was developed.

The principle circuit is shown in Fig. 15. Q1 – Q4 are drivers at the output stage, and Q6 and Q7 operate with normal small input signals. When the input signal is large, Q5 and Q8 operate in addition. When the positive input signal at normal level is impressed, Q2 and Q6 turn ON and current flows from the +B1 power source. When the input signal level increases and reaches more than +B1, Q1 and Q5 also turn on. At this time, since the emitter potential of Q5 exceeds +B1, the current does not flow from +B1 but only from +B2. When the input signal

level decreases, Q1 and Q5 are turned off, current does not flow from +B2 and current is supplied from +B1 again. When the input signal is negative, Q2 and Q6 turn off and Q3 and Q7 turn on. The operation, when input signal is negative, is the same as that of positive.

### Power indicator drive circuit

This receiver employs a power indicator which is made up of LEDs in place of a power meter. IC551 M51903L is used for the drive circuit to provide the light-on mode represented in Fig. 16 and so the power level is grasped in detail.

Fig. 17 shows the power indicator drive circuit. The power output signal from the power amplifier enters pin ④ of IC551.

The comparator circuit serves to detect the number of LEDs which light up and their intensity. The results of this detection are transmitted to the drive circuit, and the LEDs come on.

## BESCHREIBUNG DES NEUEN SCHALTKREISES

### Ausgangsschaltkreis des Dynaharmony-Verstärkers (Betriebsklasse G)

Bei den momentanen Pegelschwankungen einer Programmquelle (Musik) liegt der Prozentsatz der hohen Pegel (mehr als die Hälfte des Spitzenwertes) bei weniger als 2% des gesamten Musiksignale. Bei herkömmlichen Leistungsverstärkern sind Endstufen extrem hoher Ausgangsleistung nötig, um die Spitzenpegel ohne Verzerrungen reproduzieren zu können; dabei muß jedoch den Ausgangstransistoren ständig eine relativ hohe Spannung zugeführt werden, was zu einer hohen Leistungsaufnahme führt.

Intensive Forschungsarbeiten wurden unternommen, um einen Verstärker zu entwickeln, der trotz hoher Ausgangsleistung bei niedriger Leistungsaufnahme der Ausgangstransistoren arbeitet und einen besseren Wirkungsgrad aufweist. Es entstand die neue Dynaharmony-Endstufe (Leistungsverstärker der Betriebsklasse G). Das Prinzip dieser Schaltkreisauslegung ist in Abb. 15 dargestellt. Q1 bis Q4 sind die Treiber der Ausgangsstufe, wogegen Q6 und Q7 mit den normalerweise niedrigen Eingangssignalpegeln betrieben werden. Bei hohen Signalpegeln werden zusätzlich die Transistoren Q5 und Q8 in den Signalweg geschaltet. Wird ein positives Eingangssignal mit normalem Pegel angelegt, dann werden Q2 und Q6 leitend und ein Strom fließt von der Stromversorgung +B1 durch den Schaltkreis. Sobald der Eingangssignalpegel über den Wert von +B1 ansteigt, werden auch Q1 und Q5 leitend. Zu diesem Zeitpunkt liegt das Emitterpotential von Q5 über dem Wert von +B1, so daß die Stromversorgung nicht von +B1, sondern von +B2 erfolgt. Sinkt der Eingangssignalpegel ab, dann sperren Q1 und Q5, so daß die Stromversorgung von

+B2 abgeschaltet und die von +B1 eingeschaltet wird. Bei negativem Eingangssignal sperren Q2 und Q6, wogegen Q3 und Q7 leitend werden. Danach erfolgt der gleiche Vorgang wie bei positiven Eingangssignalen.

### Treiberschaltkreis des Leistungsmessers

Dieser Receiver ist mit einem aus Leuchtdioden (LED) gebildeten Leistungsmesser ausgerüstet. Der integrierte Schaltkreis IC551 M51903L dient als Treiberkreis des in Abb. 16 dargestellten Schaltkreises zum Ansteuern der Leuchtdioden, um die Ausgangsleistung genau anzuzeigen zu können. In Abb. 17 ist der Treiberschaltkreis des Leistungsmessers dargestellt. Die Ausgangsleistung der Endstufe gelangt an Stift ④ des Schaltkreises IC551, wonach der Komparator in Abhängigkeit von der Ausgangsleistung die Anzahl der einzuschaltenden Leuchtdioden und deren Lichtstärke bestimmt. Diese Werte werden anschließend dem Treiberkreis übermittelt, der dann die entsprechenden Leuchtdioden (LED) einschaltet.

# RENSEIGNEMENTS CONCERNANT LE NOUVEAU CIRCUIT

## Circuit de sortie dynaharmonique (Amplificateur classe G)

Le niveau du message sonore change momentanément, le pourcentage de signaux à haut niveau (plus de 1/2 de valeur de crête) est très faible, il est seulement inférieur de 2% du total des signaux du message musical. Les amplificateurs à grande puissance ont toujours été employés pour reproduire des messages à haut niveau sans distorsion; cependant et dans ce cas, une haute tension est appliquée au transistor de sortie pour que l'alimentation soit plus large. Des études ont été faites pour savoir comment on peut parvenir à des puissances de sortie élevées sans augmenter la consommation des transistors de sortie pour assurer une plus grande efficacité. C'est la raison pour laquelle le circuit de sortie dynaharmonique (amplificateur classe G) a été mis au point.

Le circuit principal est illustré par la Fig. 15. Q1 à Q4 sont alimentés au niveau de l'étage de sortie de Q6 et Q7 fonctionnent pour des signaux d'entrée à niveau normal. Quand le signal d'entrée est puissant, Q5 et Q8 fonctionnent en complément. Quand un signal d'entrée positif à niveau normal est appliqué à l'appareil, Q2 et Q6 sont commandés et le courant parvient de la source d'alimentation +B1. Quand le niveau du signal d'entrée augmente et atteint un niveau tel qu'il dépasse +B1, Q1 et Q5 sont également commandés. Dès lors, étant donné que le potentiel d'émetteur de Q5 dépasse +B1, le courant ne provient plus de +B1 mais seulement de +B2. Quand le

niveau du signal d'entrée diminue, Q1 et Q5 sont mis hors fonction, le courant ne circule plus de +B2 tandis qu'il provient maintenant de +B1. Quand le signal d'entrée est négatif, Q2 et Q6 sont mis hors fonction et Q3 et Q7 sont en fonction. Quand le signal d'entrée est négatif, le fonctionnement est identique à celui obtenu pour un signal positif.

## Circuit de commande d'indicateur de puissance

Cet ampli-tuner fait appel à un indicateur de puissance se composant de diodes électroluminescentes remplaçant le classique indicateur de puissance. Un IC551 M51903L est employé pour le circuit de commande pour assurer le mode lumineux représenté par la Figure 16 de sorte que la puissance voulue puisse être connue avec précision.

La figure 17 illustre le circuit de commande de l'indicateur de puissance. Le niveau de sortie de l'amplificateur de puissance atteint la broche ④ du IC551. Le circuit de comparaison a pour rôle de détecter le nombre de diodes électroluminescentes à allumer et leur intensité. Le résultat de cette détection est transmis au circuit de commande et les diodes électroluminescentes s'allument.

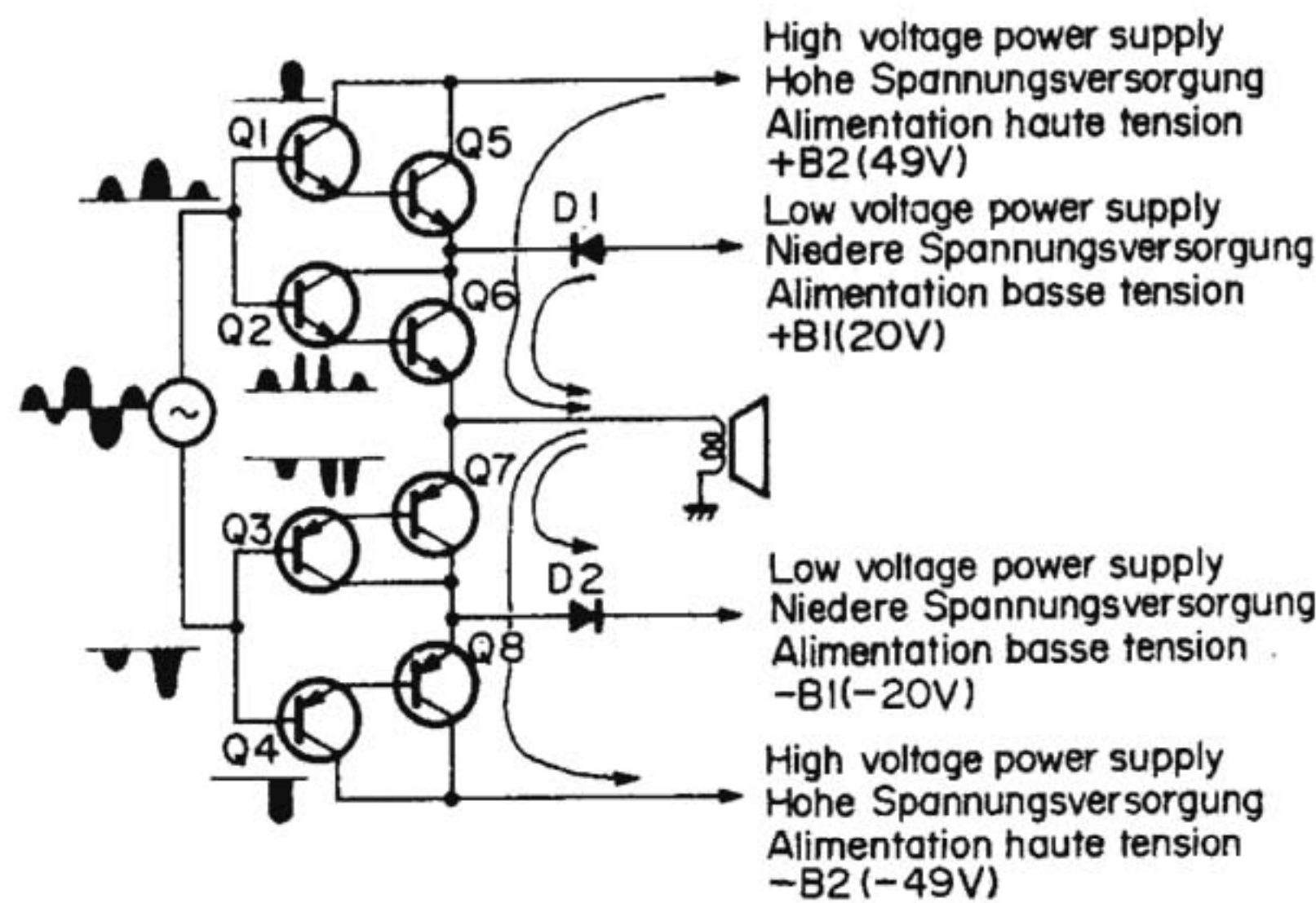
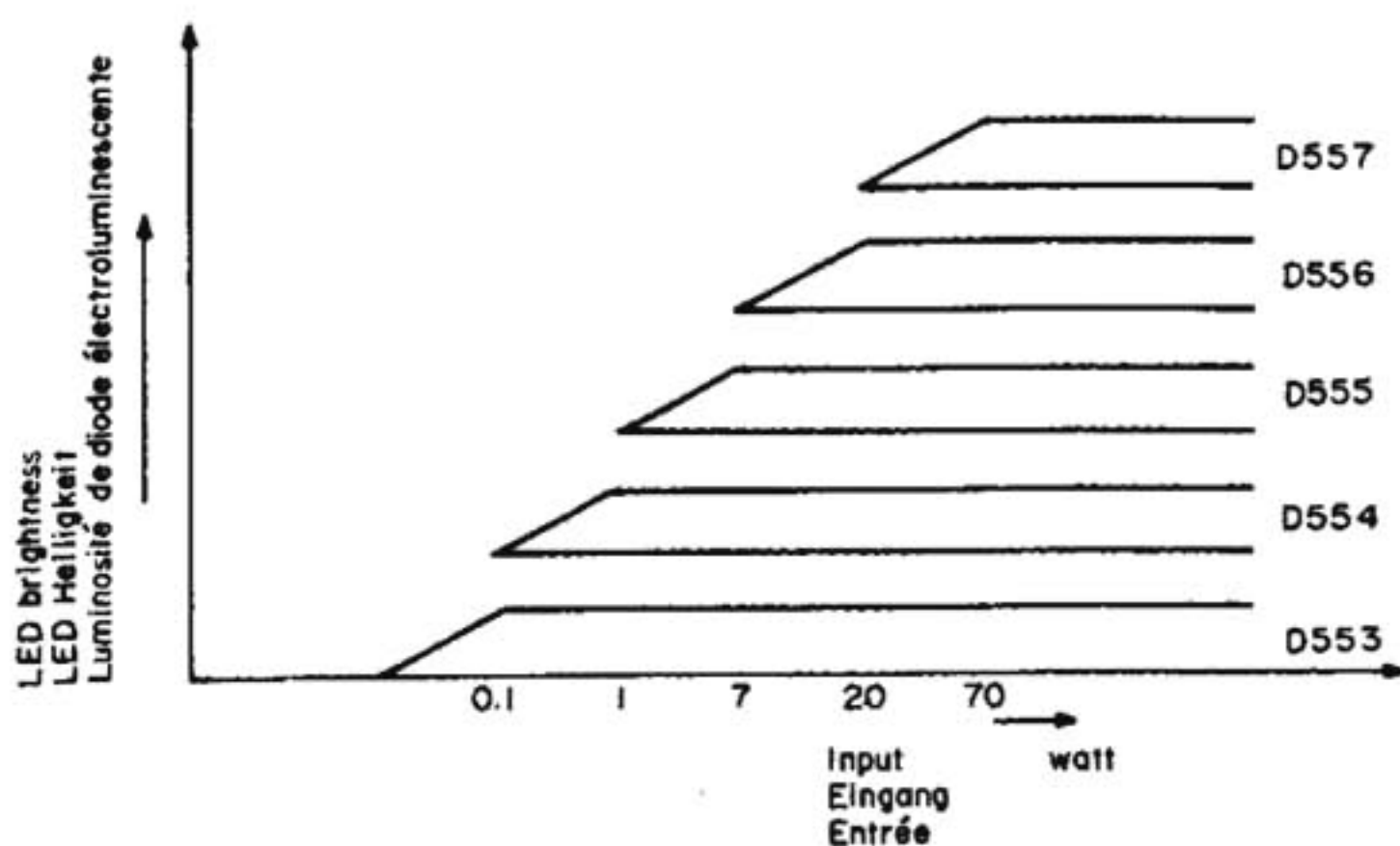
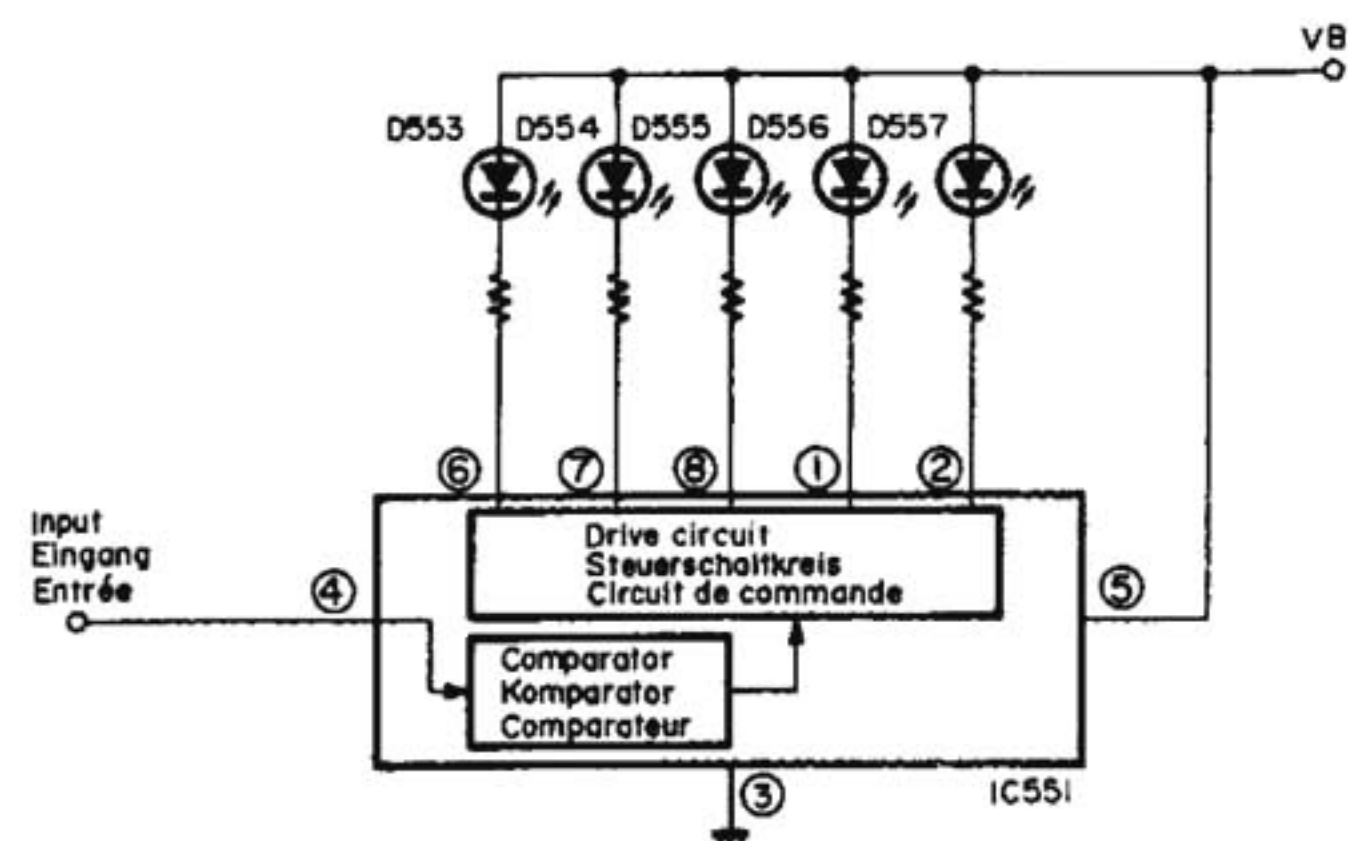

Fig. 15  
Abb. 15



Light-on mode of power indicator  
Leistungsanzeiger eingeschaltet  
Mode lumineux d'indicateur de puissance

Fig. 16  
Abb. 16



Power indicator drive circuit  
Treiberschaltkreis des Leistungsmessers  
Circuit de commande d'indicateur de puissance

Fig. 17  
Abb. 17

REPLACEMENT PARTS LIST · ERSATZTEILLISTE · TABLEAU DES PIECE

SYMBOL NO.	STOCK NO.	DESCRIPTION			SYMBOL NO.	STOCK NO.	DESCRIPTION		
<b>CAPACITORS</b>									
<b>for TUNER PRINTED WIRING BOARD</b>									
C101	1248005	Ceramic, discal	5pF ± 0.25pF	50V	C306	1274222	Mylar, film	1600pF ± 5%	50V
C102	1248362	Ceramic, discal	220pF ± 5%	50V				(for U.S.A. & Canada)	
C103	1248684	Ceramic, discal	100pF ± 5%	50V	C306	1274231	Mylar, film	1200pF ± 5%	50V
C104	H240106	Ceramic, discal	0.01μF ± 30%	25V				(except U.S.A. & Canada)	
C105	1248335	Ceramic, discal	16pF ± 5%	50V	C307	1252813	Electrolytic	3.3μF	50V
C106	1248632	Ceramic, discal	2pF ± 0.25pF	50V	C308	H252813	Electrolytic	3.3μF	50V
C107	1248362	Ceramic, discal	220pF ± 5%	50V	C309	0244175	Ceramic, discal	0.047μF ± <sup>80%</sup> / <sub>20%</sub>	50V
C108	H240106	Ceramic, discal	0.01μF ± 30%	25V	C310	0221523	Styrol	360pF ± 5%	50V
C109	H240106	Ceramic, discal	0.01μF ± 30%	25V	C311	1252811	Electrolytic	1μF	50V
C110	H240106	Ceramic, discal	0.01μF ± 30%	25V	C312	H252812	Electrolytic	2.2μF	50V
C111	H240106	Ceramic, discal	0.01μF ± 30%	25V	C313	1252873	Electrolytic	0.22μF	50V
C112	1246411	Ceramic, discal	1pF ± 0.25pF	50V	C314	1274216	Mylar, film	6800pF ± 5%	50V
C113	1246446	Ceramic, discal	18pF ± 5%	50V				(for U.S.A. & Canada)	
C114	1246707	Ceramic, discal	20pF ± 0.25%	50V	C315	1274216	Mylar, film	6800pF ± 5%	50V
C115	1246448	Ceramic, discal	22pF ± 5%	50V				(for U.S.A. & Canada)	
C116	1248044	Ceramic, discal	39pF ± 5%	50V	C316	1274222	Mylar, film	1600pF ± 5%	50V
C117	1248310	Ceramic, discal	10pF ± 5%	50V				(for U.S.A. & Canada)	
C118	0245017	Ceramic, discal	0.01μF ± <sup>80%</sup> / <sub>20%</sub>	25V	C316	1274211	Mylar, film	1000pF ± 5%	50V
C119	H252522	Electrolytic	22μF	16V				(except U.S.A. & Canada)	
C120	H240106	Ceramic, discal	0.01μF ± 30%	25V	C317	1274222	Mylar, film	1600pF ± 5%	50V
C121	0248676	Ceramic, discal	47pF ± 5%	50V				(for U.S.A. & Canada)	
C151	1248482	Ceramic, discal	2pF ± 1pF	50V	C317	1274211	Mylar, film	1000pF ± 5%	50V
C152	H240106	Ceramic, discal	0.01μF ± 30%	25V				(except U.S.A. & Canada)	
C153	H240106	Ceramic, discal	0.01μF ± 30%	25V	C318	H252811	Electrolytic	1μF	50V
C154	0228324	Styrol	360pF ± 5%	50V	C319	H252811	Electrolytic	1μF	50V
C155	H230168	Ceramic, discal	18pF ± 5%	50V	C401(L,R)	1252813	Electrolytic	3.3μF	50V
C156	H240106	Ceramic, discal	0.01μF ± 30%	25V	C402(L,R)	1252225	Electrolytic	47μF	6.3V
C157	1252811	Electrolytic	1μF	50V	C403(L,R)	H230036	Ceramic, discal	100pF ± 5%	50V
C158	H245017	Ceramic, discal	0.01μF ± <sup>80%</sup> / <sub>20%</sub>	25V	C404(L,R)	H274236	Mylar, film	8200pF ± 5%	50V
C201	H240106	Ceramic, discal	0.01μF ± 30%	25V	C405(L,R)	H274213	Mylar, film	2200pF ± 5%	50V
C202	H252812	Electrolytic	2.2μF	50V	C406(L,R)	H240002	Ceramic, discal	150pF ± 10%	50V
C203	H252813	Electrolytic	3.3μF	50V	C407(L,R)	H240101	Ceramic, discal	1500pF ± 30%	25V
C204	H252812	Electrolytic	2.2μF	50V	C408R	1252813	Electrolytic	3.3μF	50V
C205	H240106	Ceramic, discal	0.01μF ± 30%	25V	C408L	H252813	Electrolytic	3.3μF	50V
C207	0244175	Ceramic, discal	0.047μF ± <sup>80%</sup> / <sub>20%</sub>	50V	C410	1252521	Electrolytic	10μF	16V
C208	H252811	Electrolytic	1μF	50V	C411	H252521	Electrolytic	10μF	16V
C209	H240106	Ceramic, discal	0.01μF ± 30%	25V	C601(L,R)	0248688	Ceramic, discal	150pF ± 5%	50V
C210	H252811	Electrolytic	1μF	50V	C602R	H275214	Mylar, film	0.033μF ± 5%	50V
C211	1275015	Mylar, film	0.047μF ± 10%	50V	C602L	1275214	Mylar, film	0.033μF ± 5%	50V
C212	0275015	Mylar, film	0.047μF ± 10%	50V	C603(L,R)	H240020	Ceramic, discal	1000pF ± 20%	50V
C213	H240106	Ceramic, discal	0.01μF ± 30%	25V	C001	1245018	Ceramic, discal	0.022μF ± <sup>80%</sup> / <sub>20%</sub>	25V
C214	H240106	Ceramic, discal	0.01μF ± 30%	25V	<b>for AUDIO PRINTED WIRING BOARD (1)</b>				
C215	H240106	Ceramic, discal	0.01μF ± 30%	25V	C501	1252232	Electrolytic	220μF	6.3V
C216	H240106	Ceramic, discal	0.01μF ± 30%	25V	C502	1252331	Electrolytic	100μF	10V
C217	1252812	Electrolytic	2.2μF	50V	C503	H252521	Electrolytic	10μF	16V
C218	0244175	Ceramic, discal	0.047μF ± <sup>80%</sup> / <sub>20%</sub>	50V	C504	H252521	Electrolytic	10μF	16V
C219	0244175	Ceramic, discal	0.047μF ± <sup>80%</sup> / <sub>20%</sub>	50V	C505	1252873	Electrolytic	0.22μF	50V
C220	1252815	Electrolytic	4.7μF	50V	C506	H252811	Electrolytic	1μF	50V
C221	H240106	Ceramic, discal	0.01μF ± 30%	25V	C603L,R	1276011	Mylar, film	0.1μF ± 10%	50V
C222	H240106	Ceramic, discal	0.01μF ± 30%	25V	C604L,R	1276011	Mylar, film	0.1μF ± 10%	50V
C223	H240106	Ceramic, discal	0.01μF ± 30%	25V	C605L,R	1252873	Electrolytic	0.22μF ± 20%	50V
C224	H252231	Electrolytic	100μF	6.3V	C606L,R	H230036	Ceramic, discal	100pF ± 5%	50V
C225	1275013	Mylar, film	0.022μF ± 10%	50V	C607L,R	H252521	Electrolytic	10μF	16V
C226	1252811	Electrolytic	1μF	50V	C608L,R	H252521	Electrolytic	10μF	16V
C228	H252522	Electrolytic	22μF	16V	C609L,R	1276013	Mylar, film	0.22μF ± 10%	50V
C301	1252535	Electrolytic	470μF	16V	C610L,R	1275034	Mylar, film	0.039μF ± 10%	50V
C302	H252521	Electrolytic	10μF	16V	C611L,R	1275033	Mylar, film	0.027μF ± 10%	50V
C303	H252521	Electrolytic	10μF	16V	C612L,R	1274035	Mylar, film	5600pF ± 10%	50V
C304	1252521	Electrolytic	10μF	16V	C613L,R	H230036	Ceramic, discal	100pF ± 5%	50V
C305	1274222	Mylar, film	1600pF ± 5%	50V	C614L,R	H252521	Electrolytic	10μF	16V
			(for U.S.A. & Canada)		C615L,R	H240005	Ceramic, discal	270pF ± 10%	50V
C305	1274231	Mylar, film	1200pF ± 5%	50V	C715L,R	1275515	Mylar, film	0.047μF ± 10%	100V
			(except U.S.A. & Canada)						

PRODUCT SAFETY NOTE: Components marked with a  $\Delta$  have special characteristics important to safety.

SICHERHEITSHINWEIS: Die mit  $\Delta$  gekennzeichneten Komponenten haben wichtige Sicherheitsaufgaben.

NOTICE DE SECURITE DE FABRICATION: Les composants qui sont accompagnés du symbole  $\Delta$  possèdent des caractéristiques spéciales.

SYMBOL NO.	STOCK NO.	DESCRIPTION			SYMBOL NO.	STOCK NO.	DESCRIPTION		
C716L,R	1276513	Mylar, film	0.22 $\mu$ F $\pm$ 10%	100V	R151	H129567	Carbon film	180 $\Omega$ $\pm$ 5%	SRD1/8P
C801	0245408	Ceramic, discal	0.01 $\mu$ F $\pm$ 20%	500V	R152	H129621	Carbon film	6.8K $\Omega$ $\pm$ 5%	SRD1/8P
C802	0245408	Ceramic, discal	0.01 $\mu$ F $\pm$ 20%	500V	R153	H129605	Carbon film	1.5K $\Omega$ $\pm$ 5%	SRD1/8P
C803	0245408	Ceramic, discal	0.01 $\mu$ F $\pm$ 20%	500V	R154	H129549	Carbon film	56 $\Omega$ $\pm$ 5%	SRD1/8P
C804	0245408	Ceramic, discal	0.01 $\mu$ F $\pm$ 20%	500V	R155	H129651	Carbon film	68K $\Omega$ $\pm$ 5%	SRD1/8P
C805	0250338	Electrolytic	4700 $\mu$ F	63V	R156	H129609	Carbon film	2.2K $\Omega$ $\pm$ 5%	SRD1/8P
C806	0250338	Electrolytic	4700 $\mu$ F	63V	R157	H129673	Carbon film	330K $\Omega$ $\pm$ 5%	SRD1/8P
C807	0250308	Electrolytic	4700 $\mu$ F	25V	R158	H129581	Carbon film	680 $\Omega$ $\pm$ 5%	SRD1/8P
C808	0250308	Electrolytic	4700 $\mu$ F	25V	R201	H129551	Carbon film	68 $\Omega$ $\pm$ 5%	SRD1/8P
C809	H252521	Electrolytic	10 $\mu$ F	16V	R202	H129601	Carbon film	1K $\Omega$ $\pm$ 5%	SRD1/8P
C810	H252521	Electrolytic	10 $\mu$ F	16V	R203	H129575	Carbon film	390 $\Omega$ $\pm$ 5%	SRD1/8P
C811	1252631	Electrolytic	100 $\mu$ F	25V	R204	H129547	Carbon film	47 $\Omega$ $\pm$ 5%	SRD1/8P
C812	1276511	Mylar, film	0.1 $\mu$ F $\pm$ 10%	100V	R205	H129609	Carbon film	2.2K $\Omega$ $\pm$ 5%	SRD1/8P
$\Delta$ C001	0243897	Oil	0.01 $\mu$ F $\pm$ 20% (for U.S.A. & Canada)	125V	R206	H129607	Carbon film	1.8K $\Omega$ $\pm$ 5%	SRD1/8P
$\Delta$ C002	0214481	Paper	0.01 $\mu$ F $\pm$ 20% (except for U.S.A. & Canada)	450V	R207	H129575	Carbon film	390 $\Omega$ $\pm$ 5%	SRD1/8P
<b>for AUDIO PRINTED WIRING BOARD (2)</b>					R208	H129561	Carbon film	100 $\Omega$ $\pm$ 5%	SRD1/8P
C701L,R	1252877	Electrolytic	1 $\mu$ F	50V	R209	H129623	Carbon film	8.2K $\Omega$ $\pm$ 5%	SRD1/8P
C702L,R	1248732	Ceramic, discal	220pF $\pm$ 10%	50V	R210	H129635	Carbon film	15K $\Omega$ $\pm$ 5%	SRD1/8P
C703L,R	1252225	Electrolytic	47 $\mu$ F	6.3V	R211	H129665	Carbon film	150K $\Omega$ $\pm$ 5%	SRD1/8P
C704L,R	0247802	Ceramic, discal	2pF $\pm$ 0.25pF	500V	R212	H129561	Carbon film	100 $\Omega$ $\pm$ 5%	SRD1/8P
C705L,R	0247834	Ceramic, discal	15pF $\pm$ 5%	500V	R213	H129621	Carbon film	6.8K $\Omega$ $\pm$ 5%	SRD1/8P
C706L,R	0247854	Ceramic, discal	100pF $\pm$ 5%	500V	R214	H129569	Carbon film	220 $\Omega$ $\pm$ 5%	SRD1/8P
C707L,R	0243449	Ceramic, discal	470pF $\pm$ 10%	500V	R215	H129609	Carbon film	2.2K $\Omega$ $\pm$ 5%	SRD1/8P
C708L,R	1275015	Mylar, film	0.047 $\mu$ F $\pm$ 10%	50V	R216	H129619	Carbon film	5.6K $\Omega$ $\pm$ 5%	SRD1/8P
C709L,R	1275011	Mylar, film	0.01 $\mu$ F $\pm$ 10%	50V	R217	H129647	Carbon film	47K $\Omega$ $\pm$ 5%	SRD1/8P
C710L,R	1275011	Mylar, film	0.01 $\mu$ F $\pm$ 10%	50V	R218	H129635	Carbon film	15K $\Omega$ $\pm$ 5%	SRD1/8P
C711L,R	1248732	Ceramic, discal	220pF $\pm$ 10%	50V	R219	H129609	Carbon film	2.2K $\Omega$ $\pm$ 5%	SRD1/8P
C712L,R	1248732	Ceramic, discal	220pF $\pm$ 10%	50V	R220	H129561	Carbon film	100 $\Omega$ $\pm$ 5%	SRD1/8P
C713L,R	1274711	Mylar, film	1000pF $\pm$ 10%	200V	R221	H129549	Carbon film	56 $\Omega$ $\pm$ 5%	SRD1/8P
C714L,R	1274711	Mylar, film	1000pF $\pm$ 10%	200V	R222	H129605	Carbon film	1.5K $\Omega$ $\pm$ 5%	SRD1/8P
C751	1252811	Electrolytic	1 $\mu$ F	50V	R223	H129613	Carbon film	3.3K $\Omega$ $\pm$ 5%	SRD1/8P
C752	1252811	Electrolytic	1 $\mu$ F	50V	R224	H129669	Carbon film	220K $\Omega$ $\pm$ 5%	SRD1/8P
<b>for SUB PRINTED WIRING BOARD</b>					R225	H129575	Carbon film	390 $\Omega$ $\pm$ 5%	SRD1/8P
C551L,R	1252871	Electrolytic	0.1 $\mu$ F	50V	R226	H129643	Carbon film	33K $\Omega$ $\pm$ 5%	SRD1/8P
C552L,R	1252521	Electrolytic	10 $\mu$ F	16V	R227	H129609	Carbon film	2.2K $\Omega$ $\pm$ 5%	SRD1/8P
<b>RESISTORS</b>					R228	H129631	Carbon film	10K $\Omega$ $\pm$ 5%	SRD1/8P
<b>for TUNER PRINTED WIRING BOARD</b>					R229	H129609	Carbon film	2.2K $\Omega$ $\pm$ 5%	SRD1/8P
R101	H129661	Carbon film	100K $\Omega$ $\pm$ 5%	SRD1/8P	R230	H129619	Carbon film	5.6K $\Omega$ $\pm$ 5%	SRD1/8P
R102	H129563	Carbon film	120 $\Omega$ $\pm$ 5%	SRD1/8P	R231	H129651	Carbon film	68K $\Omega$ $\pm$ 5%	SRD1/8P
R103	H129607	Carbon film	1.8K $\Omega$ $\pm$ 5%	SRD1/8P	R232	H129671	Carbon film	270K $\Omega$ $\pm$ 5%	SRD1/8P
R104	H129619	Carbon film	5.6K $\Omega$ $\pm$ 5%	SRD1/8P	R233	H129615	Carbon film	3.9K $\Omega$ $\pm$ 5%	SRD1/8P
R105	H129547	Carbon film	47 $\Omega$ $\pm$ 5%	SRD1/8P	R234	H129601	Carbon film	1K $\Omega$ $\pm$ 5%	SRD1/8P
R106	H129635	Carbon film	15K $\Omega$ $\pm$ 5%	SRD1/8P	R235	H129661	Carbon film	100K $\Omega$ $\pm$ 5%	SRD1/8P
R107	H129601	Carbon film	1K $\Omega$ $\pm$ 5%	SRD1/8P	R237	H129621	Carbon film	6.8K $\Omega$ $\pm$ 5%	SRD1/8P
R108	H129617	Carbon film	4.7K $\Omega$ $\pm$ 5%	SRD1/8P	R301	H129645	Carbon film	39K $\Omega$ $\pm$ 5%	SRD1/8P
R109	H129601	Carbon film	1K $\Omega$ $\pm$ 5%	SRD1/8P	R302	H129553	Carbon film	82 $\Omega$ $\pm$ 5%	SRD1/8P
R110	H129561	Carbon film	100 $\Omega$ $\pm$ 5%	SRD1/8P	R303	H129643	Carbon film	33K $\Omega$ $\pm$ 5%	SRD1/8P
R111	H129553	Carbon film	82 $\Omega$ $\pm$ 5%	SRD1/8P	R304	H129643	Carbon film	33K $\Omega$ $\pm$ 5%	SRD1/8P
R112	H129623	Carbon film	8.2K $\Omega$ $\pm$ 5%	SRD1/8P	R305	H129631	Carbon film	10K $\Omega$ $\pm$ 5%	SRD1/8P
R113	H129639	Carbon film	22K $\Omega$ $\pm$ 5%	SRD1/8P	R306	H129631	Carbon film	10K $\Omega$ $\pm$ 5%	SRD1/8P
R114	H129601	Carbon film	1K $\Omega$ $\pm$ 5%	SRD1/8P	R308	H129647	Carbon film	47K $\Omega$ $\pm$ 5%	SRD1/8P
R115	H129561	Carbon film	100 $\Omega$ $\pm$ 5%	SRD1/8P	R309	H129647	Carbon film	47K $\Omega$ $\pm$ 5%	SRD1/8P
					R310	H129605	Carbon film	1.5K $\Omega$ $\pm$ 5%	SRD1/8P
					R311	H129605	Carbon film	1.5K $\Omega$ $\pm$ 5%	SRD1/8P
					R312	0110820	Metal	24K $\Omega$ $\pm$ 1%	RN1/4B
					R314	H129601	Carbon film	1K $\Omega$ $\pm$ 5%	SRD1/8P
					R315	H129665	Carbon film	150K $\Omega$ $\pm$ 5%	SRD1/8P
					R316	H129665	Carbon film	150K $\Omega$ $\pm$ 5%	SRD1/8P
					R317	H134373	Composition	1K $\Omega$ $\pm$ 10%	RC1/2GF
					R318	H129631	Carbon film	10K $\Omega$ $\pm$ 5%	SRD1/8P
					R319	H129631	Carbon film	10K $\Omega$ $\pm$ 5%	SRD1/8P
					R321	H129613	Carbon film	3.3K $\Omega$ $\pm$ 5%	SRD1/8P
					R322	H129613	Carbon film	3.3K $\Omega$ $\pm$ 5%	SRD1/8P
					R323	H129615	Carbon film	3.9K $\Omega$ $\pm$ 5%	SRD1/8P
					R324	H129615	Carbon film	3.9K $\Omega$ $\pm$ 5%	SRD1/8P
					R325	H129639	Carbon film	22K $\Omega$ $\pm$ 5%	SRD1/8P
					R326	H129639	Carbon film	22K $\Omega$ $\pm$ 5%	SRD1/8P
					R401(L,R)	H129605	Carbon film	1.5K $\Omega$ $\pm$ 5%	SRD1/8P

# HITACHI SR-604

SYMBOL NO.	STOCK NO.	DESCRIPTION			SYMBOL NO.	STOCK NO.	DESCRIPTION							
R402(L,R)	H129647	Carbon film	47KΩ ± 5%	SRD1/8P	R709L,R	H114203	Carbon film	12KΩ ± 5%	SRD1/4P					
R403(L,R)	H129581	Carbon film	680Ω ± 5%	SRD1/8P	R710L,R	H114133	Carbon film	120Ω ± 5%	SRD1/4P					
R404(L,R)	H129631	Carbon film	10KΩ ± 5%	SRD1/8P	R711L,R	0110609	Metal	47Ω ± 5%	RN1/4B					
R405(L,R)	H129601	Carbon film	1KΩ ± 5%	SRD1/8P	↑		(Fuse resistor)							
R406(L,R)	0129676	Carbon film	430KΩ ± 5%	SRD1/8P			R712L,R	H114139	Carbon film	220Ω ± 5%	SRD1/4P			
R407(L,R)	H129643	Carbon film	33KΩ ± 5%	SRD1/8P			R713L,R	0117390	Metal oxide	820Ω ± 5%	RS1/4B			
R408(L,R)	H129565	Carbon film	150Ω ± 5%	SRD1/8P			↑		(Fuse resistor)					
R409(L,R)	H129617	Carbon film	4.7KΩ ± 5%	SRD1/8P					R714L,R	0117391	Metal oxide	1KΩ ± 5%	RS1/4B	
R410(L,R)	H129661	Carbon film	100KΩ ± 5%	SRD1/8P			↑		(Fuse resistor)					
R412(L,R)	H129663	Carbon film	120KΩ ± 5%	SRD1/8P					R715L,R	0110628	Metal	390Ω ± 5%	RN1/4B	
							(except for U.S.A. & Canada)							
R413(L,R)	H129671	Carbon film	270KΩ ± 5%	SRD1/8P			↑		(Fuse resistor)					
									R716L,R	H114289	Carbon film	220KΩ ± 5%	SRD1/4P	
					R717L,R	H114223			Carbon film	82KΩ ± 5%	SRD1/4P			
					R718L,R	H114223			Carbon film	82KΩ ± 5%	SRD1/4P			
					R719L,R	H114207			Carbon film	18KΩ ± 5%	SRD1/4P			
R601(L,R)	H129633	Carbon film	12KΩ ± 5%	SRD1/8P	R720L,R	H114207	Carbon film	18KΩ ± 5%	SRD1/4P					
					R721L,R	0110628	Metal	390Ω ± 5%	RN1/4B					
R603	0129663	Carbon film	120KΩ ± 5%	SRD1/8P	↑		(Fuse resistor)							
for AUDIO PRINTED WIRING BOARD (1)					R722L,R	0110628	Metal	390Ω ± 5%	RN1/4B					
					R723L,R	H114201	Carbon film	10KΩ ± 5%	SRD1/4P					
					R724L,R	H114201	Carbon film	10KΩ ± 5%	SRD1/4P					
					R725L,R	H114131	Carbon film	100Ω ± 5%	SRD1/4P					
					R726L,R	H114131	Carbon film	100Ω ± 5%	SRD1/4P					
					R727L,R	0110621	Metal	100Ω ± 5%	SRD1/4P					
					R501	H114219	Carbon film	56KΩ ± 5%	SRD1/4P	↑		(Fuse resistor)		
												R728L,R	0110621	Metal
					R502	H114219	Carbon film	56KΩ ± 5%	SRD1/4P	↑		(Fuse resistor)		
					R503	H114289	Carbon film	220KΩ ± 5%	SRD1/4P			R729L,R	1119123	Metal
R504	H114211	Carbon film	27KΩ ± 5%	SRD1/4P	R730L,R	1119123	Metal	0.22Ω ± 10%	RN2B					
R505	H134379	Composition	3.3KΩ ± 10%	RC1/2GF	R751	H134381	Composition	4.7KΩ ± 10%	RC1/2GF					
R506	H134379	Composition	3.3KΩ ± 10%	RC1/2GF	R752	H134381	Composition	4.7KΩ ± 10%	RC1/2GF					
R507	H134379	Composition	3.3KΩ ± 10%	RC1/2GF	R801	1119542	Metal oxide	1.2KΩ ± 10%	RS2B					
R508	H134379	Composition	3.3KΩ ± 10%	RC1/2GF										
R509	H134385	Composition	10KΩ ± 10%	RC1/2GF										
R510	H134385	Composition	10KΩ ± 10%	RC1/2GF										
R511	H134385	Composition	10KΩ ± 10%	RC1/2GF										
R512	H134385	Composition	10KΩ ± 10%	RC1/2GF										
R513	H134381	Composition	4.7KΩ ± 10%	RC1/2GF										
R514	H114161	Carbon film	1KΩ ± 5%	SRD1/4P										
R515	H114205	Carbon film	15KΩ ± 5%	SRD1/4P										
R516	H114281	Carbon film	100KΩ ± 5%	SRD1/4P										
R604L,R	H114161	Carbon film	1KΩ ± 5%	SRD1/4P	for AUDIO PRINTED WIRING BOARD (3)									
R606L,R	H114219	Carbon film	56KΩ ± 5%	SRD1/4P	R001	0139005	Composition	2.7MΩ ± 10%	RC1/2GF					
R607L,R	H114311	Carbon film	1MΩ ± 5%	SRD1/4P	(for U.S.A. & Canada)									
R608L,R	H114283	Carbon film	120KΩ ± 5%	SRD1/4P	for SUB PRINTED WIRING BOARD									
R609L,R	H114213	Carbon film	33KΩ ± 5%	SRD1/4P	R551L,R	H114177	Carbon film	4.7KΩ ± 5%	SRD1/4P					
R610L,R	H114171	Carbon film	2.7KΩ ± 5%	SRD1/4P	R552L,R	H114135	Carbon film	150Ω ± 5%	SRD1/4P					
R611L,R	H114153	Carbon film	820Ω ± 5%	SRD1/4P	R553L,R	H114161	Carbon film	1KΩ ± 5%	SRD1/4P					
R612L,R	H114203	Carbon film	12KΩ ± 5%	SRD1/4P	R554L,R	H114041	Carbon film	10Ω ± 5%	SRD1/4P					
R613L,R	H114205	Carbon film	15KΩ ± 5%	SRD1/4P	R555L,R	H114165	Carbon film	1.5KΩ ± 5%	SRD1/4P					
R614L,R	H114281	Carbon film	100KΩ ± 5%	SRD1/4P	R556L,R	H114165	Carbon film	1.5KΩ ± 5%	SRD1/4P					
R615L,R	H114151	Carbon film	680Ω ± 5%	SRD1/4P	R557L,R	H114165	Carbon film	1.5KΩ ± 5%	SRD1/4P					
R616L,R	H114175	Carbon film	3.9KΩ ± 5%	SRD1/4P	R558L,R	H114165	Carbon film	1.5KΩ ± 5%	SRD1/4P					
R619L,R	H114177	Carbon film	4.7KΩ ± 5%	SRD1/4P	R559L,R	H114165	Carbon film	1.5KΩ ± 5%	SRD1/4P					
					R560L,R	0114209	Carbon film	22KΩ ± 5%	SRD1/4P					
R732L,R	H134289	Composition	10Ω ± 10%	RC1/2GF	FET, ICs & TRANSISTORS									
R733L,R	1119045	Metal	22Ω ± 10%	RN1B	for TUNER PRINTED WIRING BOARD									
R734L,R	1119025	Metal	2.2Ω ± 10%	RN1B	IC201	2367281	HA11211							
R735L,R	H134370	Composition	560Ω ± 10%	RC1/2GF	IC301	2367271	HA1196							
R736L,R	H134370	Composition	560Ω ± 10%	RC1/2GF	IC401	2367152	HA1452W							
for AUDIO PRINTED WIRING BOARD (2)					Q101	2327433	FET - 3SK45 (B) BK							
R701L,R	H114161	Carbon film	1KΩ ± 5%	SRD1/4P	Q102	0573510	2SC535 (B)							
R702L,R	H114281	Carbon film	100KΩ ± 5%	SRD1/4P	Q103	0573507	2SC461 (B)							
R703L,R	H114183	Carbon film	8.2KΩ ± 5%	SRD1/4P	Q151	0573491	2SC454 (B)							
R704L,R	H114281	Carbon film	100KΩ ± 5%	SRD1/4P										
R705L,R	H114139	Carbon film	220Ω ± 5%	SRD1/4P										
R706L,R	H114139	Carbon film	220Ω ± 5%	SRD1/4P										
R707L,R	H114139	Carbon film	220Ω ± 5%	SRD1/4P										
R708L,R	H114183	Carbon film	8.2KΩ ± 5%	SRD1/4P	Q201	0573486	2SC460 (B)							

SYMBOL NO.	STOCK NO.	DESCRIPTION	SYMBOL NO.	STOCK NO.	DESCRIPTION
Q202	2328653	2SC1740LN (E)	D711L,R	2328031	U06C
Q301	2328282	2SC458 (C)	D712L,R	2328031	U06C
Q302	2328282	2SC458 (C)	ZD751	2337184	HZ - 16 - 1
			ZD752	2337184	HZ - 16 - 1
<b>for AUDIO PRINTED WIRING BOARD (1)</b>			D801	2337461	S4VB20
IC501	2367372	HA12002	D802	2337461	S4VB20
IC601	2367152	HA1452W	ZD801	2337483	AW08 - 13
Q501	2328773	2SA1038 (E)	ZD802	2337483	AW08 - 13
Q801	2328422	2SD478 (C)	ZD803	2337103	HZ - 12 (C)
<b>for AUDIO PRINTED WIRING BOARD (2)</b>			VA701L,R	2347042	MV - 5W
Q701L,R	2328783	2SC2389 (E)	<b>for SUB PRINTED WIRING BOARD</b>		
Q702L,R	2328783	2SC2389 (E)	D551L,R	0575002	1N34A
Q703L,R	2328773	2SA1038 (E)	D552L,R	2337011	1S2076
Q704L,R	2328862	2SB716 (E)	D553L,R	2337721	LED (Red)
Q705L,R	2328872	2SD756 (E)	D554L,R	2337721	LED (Red)
Q706L,R	2328783	2SC2389 (E)	D555L,R	2337721	LED (Red)
Q707L,R	2328773	2SA1038 (E)	D556L,R	2337721	LED (Red)
Q708L,R	2328635	2SD667 (C)	D557L,R	2337721	LED (Red)
Q709L,R	2328625	2SB647 (C)	<b>for MECHANICAL PLATE ASSEMBLY</b>		
Q710L,R	2328635	2SD667 (C)	D001	2337721	LED (Stereo indicator)
Q711L,R	2328625	2SB647 (C)	<b>VARIABLE RESISTORS</b>		
Q712L,R	2328118	2SD586 (1) (R)	<b>for TUNER PRINTED WIRING BOARD</b>		
Q713L,R	2328108	2SB616 (1) (R)	R236	0151225	50K $\Omega$ - (B) (FM output adj.)
Q714L,R	2328112	2SD586 (R)	R307	0151284	300K $\Omega$ - (B) (Separation adj.)
Q715L,R	2328102	2SB616 (R)	R313	0151224	10K $\Omega$ - (B) (VCO adj.)
<b>for SUB PRINTED WIRING BOARD</b>			R602L,R	0151856	200K $\Omega$ - (B) (VOLUME)
IC551L,R	2367391	M51903L	<b>for AUDIO PRINTED WIRING BOARD (1)</b>		
<b>DIODES</b>			R605	0151679	200K $\Omega$ - (W) (BALANCE)
<b>for TUNER PRINTED WIRING BOARD</b>			R617L,R	0151673	50K $\Omega$ - (C) (TREBLE)
D101	2337011	1S2076	R618L,R	0151673	50K $\Omega$ - (C) (BASS)
D201	2337011	1S2076	<b>for AUDIO PRINTED WIRING BOARD (2)</b>		
D202	0575002	1N34A	R731 L,A	0151306	300 $\Omega$ - (B) (Idle current adj.)
D203	0575002	1N34A	<b>COILS &amp; TRANSFORMERS</b>		
D204	2337011	1S2076	<b>for TUNER PRINTED WIRING BOARD</b>		
D205	2337011	1S2076	L101	2227351	Choke coil (1 $\mu$ H)
D301	2337011	1S2076	L102	2134471	FM OSC coil
D302	2337011	1S2076	L151	2227353	Choke coil (100 $\mu$ H)
D303	2337011	1S2076	L153	2134431	AM OSC coil
ZD301	2337431	HZ - 3 (A)	L201	2227351	Choke coil (1 $\mu$ H)
<b>for AUDIO PRINTED WIRING BOARD (1)</b>			L202	2227271	Choke coil (18 $\mu$ H)
D501	2337151	1S2076A	L203	2227351	Choke coil (1 $\mu$ H)
D502	2337151	1S2076A	T101	2134741	FM antenna coil
<b>for AUDIO PRINTED WIRING BOARD (2)</b>			T102	2134743	FM RF coil
D701L,R	2337011	1S2076	T151	2154341	AM IF transformer
D702L,R	2337011	1S2076	T201	2154291	FM IF transformer
D703L,R	2337641	1SS81			
D704L,R	2337011	1S2076			
D705L,R	2337641	1SS81			
D706L,R	2337641	1SS81			
D707L,R	2337011	1S2076			
D708L,R	2337011	1S2076			
D709L,R	2337011	1S2076			

SYMBOL NO.	STOCK NO.	DESCRIPTION	SYMBOL NO.	STOCK NO.	DESCRIPTION
T202	2154271	FM discriminating transformer		2647587	LED holder
T251	2154122	AM IF transformer		2577431	Meter (Tuning)
				2577432	Meter (Signal)
				4093671	Lamp cover ass'y
<b>for AUDIO PRINTED WIRING BOARD (1)</b>			<b>for REAR PLATE ASSEMBLY</b>		
L701L,R	2227143	Audio trap coil (2.2 $\mu$ H)		4567432	3 $\phi$ x 8DT bind screw ⑭
				4567444	4 $\phi$ x 12DT bind screw ⑮
				4770255	4 $\phi$ flanged nut
				4090092	Ground screw
				4567432	3 $\phi$ x 8DT bind screw (Black) ⑰
				4567412	3 $\phi$ x 8DT bind screw (Yellow) ⑱
				4784106	3 $\phi$ x 10 bind tapping screw (for Asia & Latin American countries) (VOLTAGE SELECTOR)
				4567432	3 $\phi$ x 8DT bind screw ⑲ (except for U.S.A. & Canada)
				4567411	3 $\phi$ x 6DT bind screw ⑳
				2687653	3P antenna terminal
<b>MISCELLANEOUS</b>			<b>for FINAL ASSEMBLY</b>		
CV101-103 CV151, 152	0281169	Variable capacitor		3285474	Knob-push knob (for POWER)
CT103	0283122	Trimmer capacitor		3284973	Knob-push knob (SPEAKERS, others)
MF201	2134547	Ceramic filter		3284871	Knob (TUNING)
MF202	2134547	Ceramic filter		3285291	Knob (VOLUME)
MF203	2134547	Ceramic filter		3284851	Knob (BASS, others)
CP301	2134791	Leak filter		3160391	Bottom plate ass'y ⑤
S401	2617603	Switch-rotary switch (for FUNCTION)		4743392	Ring
S402, 403	2637995	Switch-push switch (for TAPE MONITOR 1, 2)		4743393	Ring (L)
S601-603	2638004	Switch-push switch (for FM MODE, LOUDNESS, SUBSONIC FILTER)		2507551	SUB P.W.B. ass'y
S701-702	2638013	Switch-push switch (for SPEAKERS)		4567413	3 $\phi$ x 10DT bind screw ⑥
	2677391	2P US pin jack		0812114	3 $\phi$ flanged nut
	2677392	4P US pin jack		4567411	3 $\phi$ x 6DT bind screw ⑦
	2777011	Ferrite core		4567442	4 $\phi$ x 8DT bind screw ⑧
	2748792	Cord with 4P connector		4399021	Washer ⑨
	2688051	Speaker terminal		4567438	3 $\phi$ x 25DT bind screw
PL501	2647112	Power relay			
J001	2677501	Headphone jack			
	2667283	4P minature connector			
	2667251	4P pin connector			
	2667321	6P pin connector			
	4405651	Transistor holder ⑳			
	3929062	Bushing (for transistor)			
	2667264	Connector-4P connector			
	2667265	Connector-6P connector			
<b>for DIAL MECHANISM ASSEMBLY</b>			<b>for ACCESSORY</b>		
	3387281	Dial pointer ass'y		2748832	FM antenna
	0666704	Wire clip			
	3337201	Spring			
	4567412	3 $\phi$ x 8DT bind screw			
<b>for CHASSIS ASSEMBLY</b>					
	3920803	Pulley			
	4567411	3 $\phi$ x 6DT bind screw (Yellow) ⑯			
	4567452	3 $\phi$ x 8DT bind screw (Silver) ⑩			
	4567412	3 $\phi$ x 8DT bind screw (Yellow) ⑪			
	4567432	3 $\phi$ x 8DT bind screw (Black) ⑫			
	4784106	3 $\phi$ x 10 bind tapping screw ⑬			
<b>for MECHANICAL PLATE ASSEMBLY</b>					
	4574321	Flywheel ass'y			
	4113441	9 $\phi$ nut			
	4407483	Dial scale			

SYMBOL NO.	STOCK NO.	DESCRIPTION	U.S.A.	Canada	France & W. Germany	U.K.	Australia	Asia & Latin American countries
	2507255	Tuner P.W. B. ass'y ①	○	○				
	2507256	Tuner P.W.B. ass'y ①	○	○	○	○	○	○
	2507541	Audio P.W.B. ass'y ②	○	○	○	○	○	○
	2507542	Audio P.W.B. ass'y ②	○	○	○	○	○	○
	3245952	Escutcheon ass'y ③	○	○	○	○	○	○
	3245951	Escutcheon ass'y ③	○	○	○	○	○	○
	4093341	Top cover ass'y(Walnut)④	○	○	○	○	○	○
	4093342	Top cover ass'y (Black) ④	○	○	○	○	○	○
▲ S001	2638222	Power switch	○	○	○	○	○	○
▲ S001	2638221	Power switch	○	○	○	○	○	○
	3913006	Bushing	○	○	○	○	○	○
	0043793	Bushing	○	○	○	○	○	○
	3913001	Bushing	○	○	○	○	○	○
	3715183	Bushing	○	○	○	○	○	○
▲	2748862	AC line cord	○	○	○	○	○	○
▲	2748751	AC line cord	○	○	○	○	○	○
▲	2748741	AC line cord	○	○	○	○	○	○
▲	2747302	AC line cord	○	○	○	○	○	○
	3920381	AC outlet cover	○	○	○	○	○	○
▲ T001	2218871	Power transformer	○	○	○	○	○	○
▲ T001	2218872	Power transformer	○	○	○	○	○	○
	2657281	AC outlet	○	○	○	○	○	○
	2677461	Antenna socket	○	○	○	○	○	○
	2627221	Switch-slide switch	○	○	○	○	○	○
	2657401	DIN 5P socket	○	○	○	○	○	○
▲ F001	2727566	Fuse-4A, 125V	○	○	○	○	○	○
▲ F001	2727194	Fuse-T1.6A, 250V	○	○	○	○	○	○
	2657371	E socket adaptor	○	○	○	○	○	○
	2727196	Fuse-T3.15A } for ACCESSORY	○	○	○	○	○	○