

**TRANSISTOR CASSETTE
TAPE PLAYER
MODEL TPQ-201
SERVICE MANUAL**

No. 278

1970

SPECIFICATIONS

TRANSISTORS

Q1 2SB75Pre. Amp.
 Q2 2SC458Pre. Amp.
 Q3 2SC458AF Amp.
 Q4 2SB156 }Power Amp.
 Q5 2SB156 }

THRMISTORS

TH1 D-1E }Temperature Compensator
 TH2 D-1E }

TAPECompact cassette

TAPE SPEED1 $\frac{7}{8}$ ips (4.75cm/s)

TRACK SYSTEMMonaural dual track

SPEAKER3" (7.7cm) P.M.

AUDIO OUTPUT500mW

FREQUENCY RANGE100 - 7,000Hz

OUTPUT IMPEDANCE8 ohms

POWER SUPPLYDC:6V (JIS "UM-2" \times 4 or equivalent)

DIMENSIONS2 $\frac{3}{8}$ "(H) \times 4 $\frac{3}{4}$ "(W) \times 8 $\frac{2}{3}$ "(D)
 (6.3 \times 12 \times 22cm)

WEIGHT2 lbs. 14 oz. (1.3kg) with batteries

CONTROLS

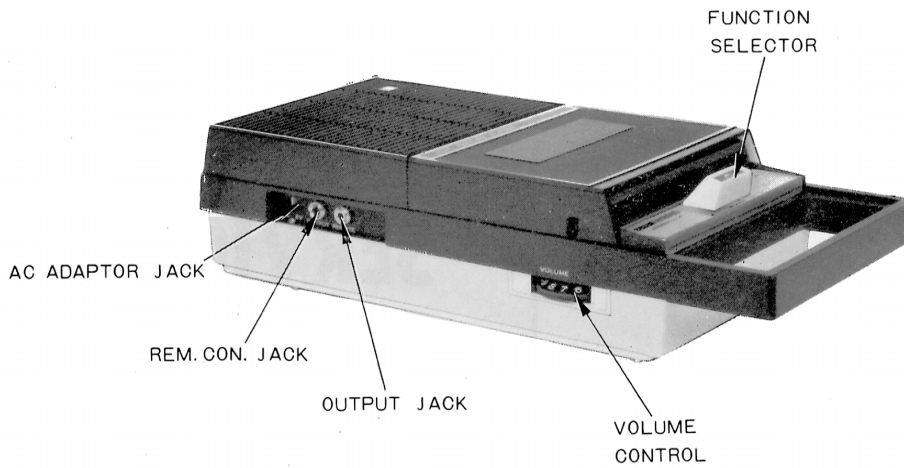

Fig. 1

DISASSEMBLY

When inspecting, repairing and lubricating, disassemble the tape player in the following manner.

1. Removal of bottom case

Remove two screws holding bottom case as shown in Fig. 2.

2. Removal of upper case

Pull out function selector.

Remove two screws holding upper case as shown in Fig. 3, and the one screw holding chassis shown in Fig. 4.

Since the speaker and its wire are attached to this case, be careful not to cut wires accidentally.

3. Removal of circuit board

Remove two screws holding circuit board as shown in Fig. 4. Also remove one screw holding power transistor (tightened to the chassis with bolt and nut).

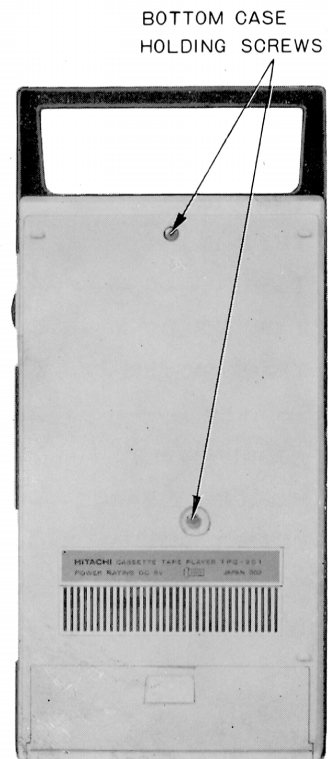

Fig. 2

UPPER CASE HOLDING SCREWS

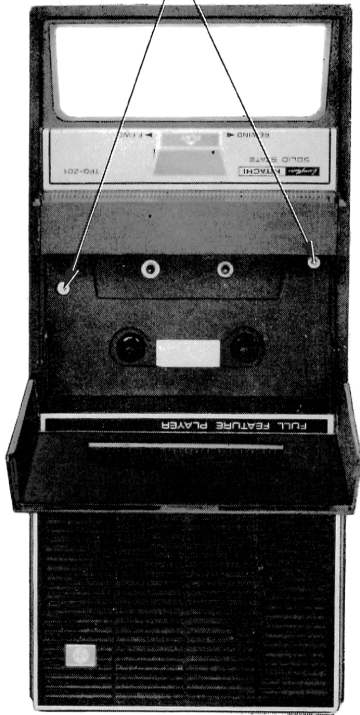

Fig. 3

CIRCUIT BOARD HOLDING SCREWS

POWER TRANSISTOR HOLDING SCREW

CHASSIS HOLDING SCREW

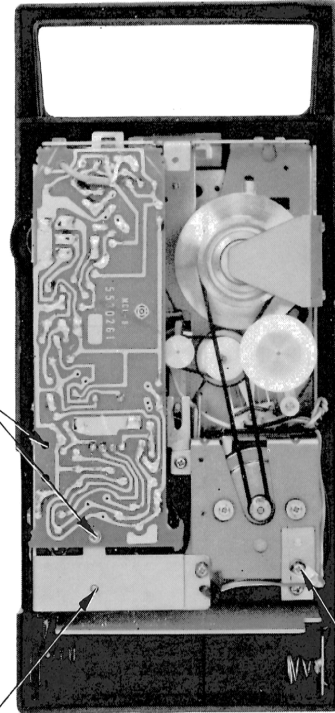

Fig. 4

LUBRICATION

Oil the parts shown in Fig. 5 and 6.

NOTE: When lubricating be sure to keep the pressure roller, the tape contacting face of the capstan, belt and idler from oil. If oil is deposited on belt, idler, capstan, pressure roller and so on, they will slip. Be sure to wipe the oil with alcohol.

(G) : Grease (P) : Pan motor oil No. 30

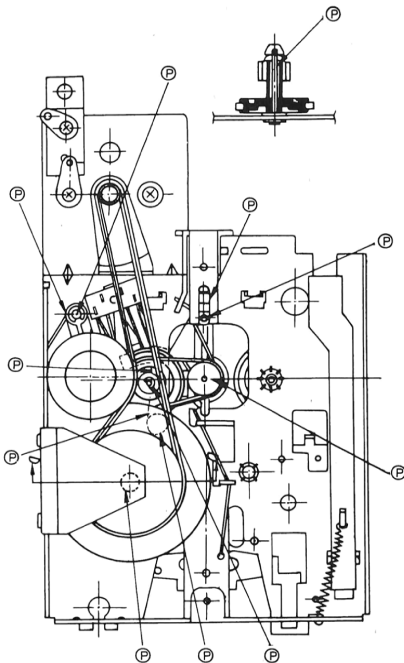

Fig. 5

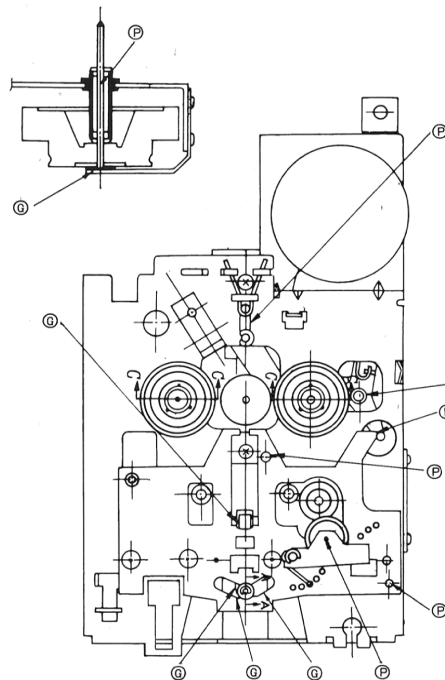
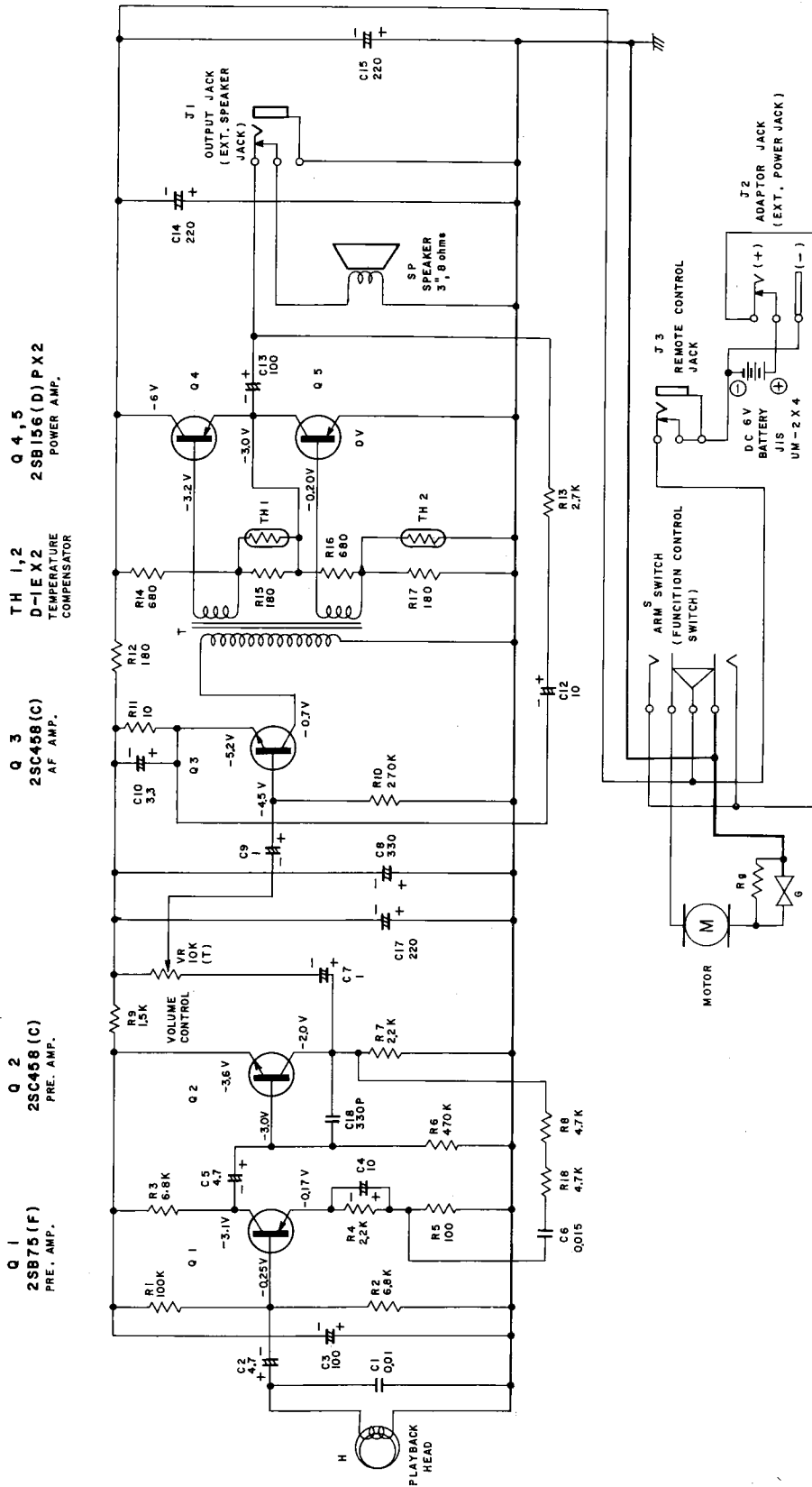

Fig. 6

CIRCUIT DIAGRAM



NOTE: 1. VOLTAGE MEASURED WITH VOLTMETER AT 6V DC, BASE OF ⊕ SIDE POWER SUPPLY, VOLUME CONTROL AT MINIMUM AND NO SIGNAL.

2. ALL RESISTANCE VALUES IN OHMS. K=1000

3. ALL CAPACITANCE VALUES IN μF EXCEPT "P" NOTED. P=μμF = PF

CIRCUIT BOARD DIAGRAM

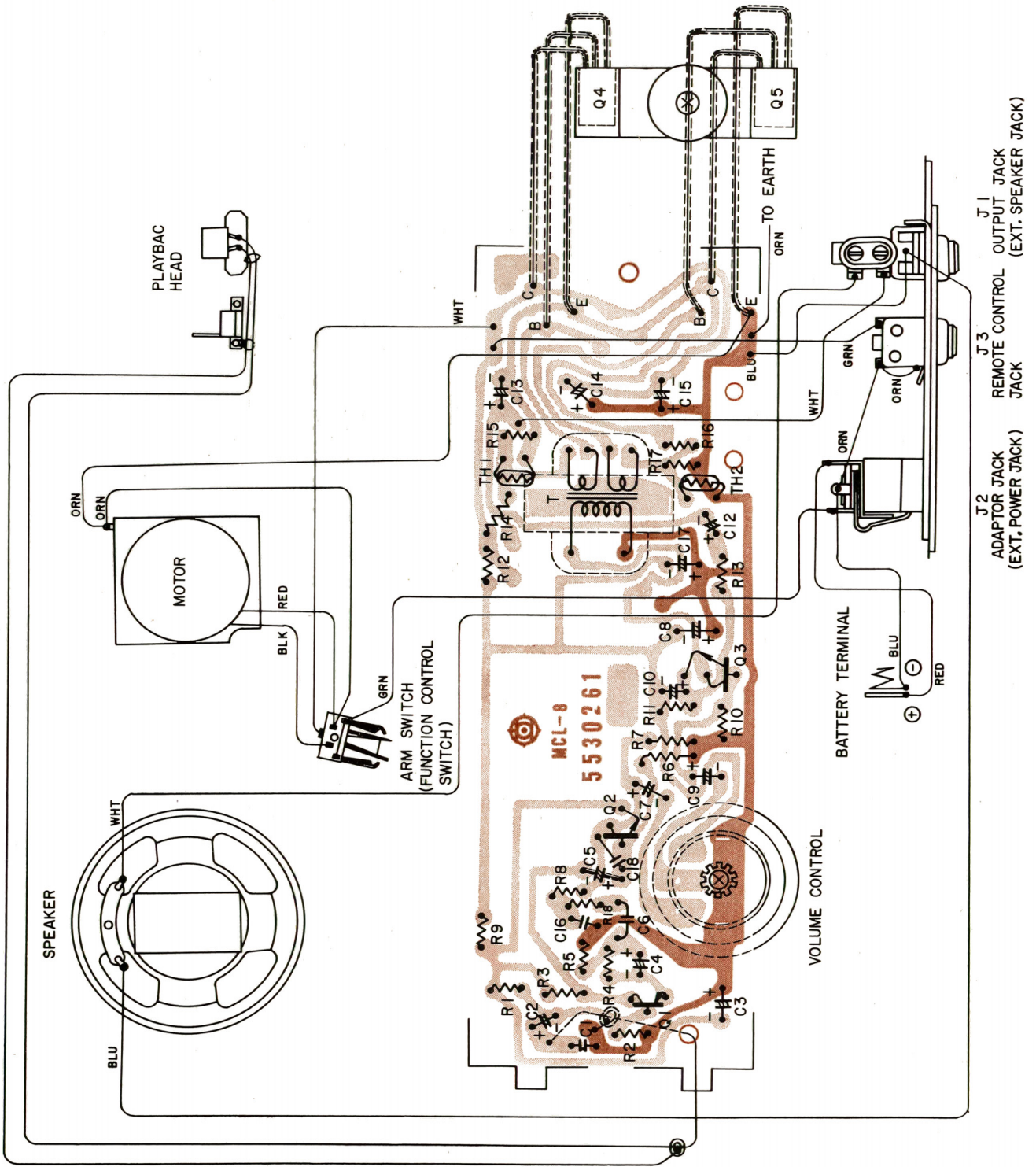

MODEL TPQ-201 SERVICE MANUAL

DISASSEMBLED DIAGRAM

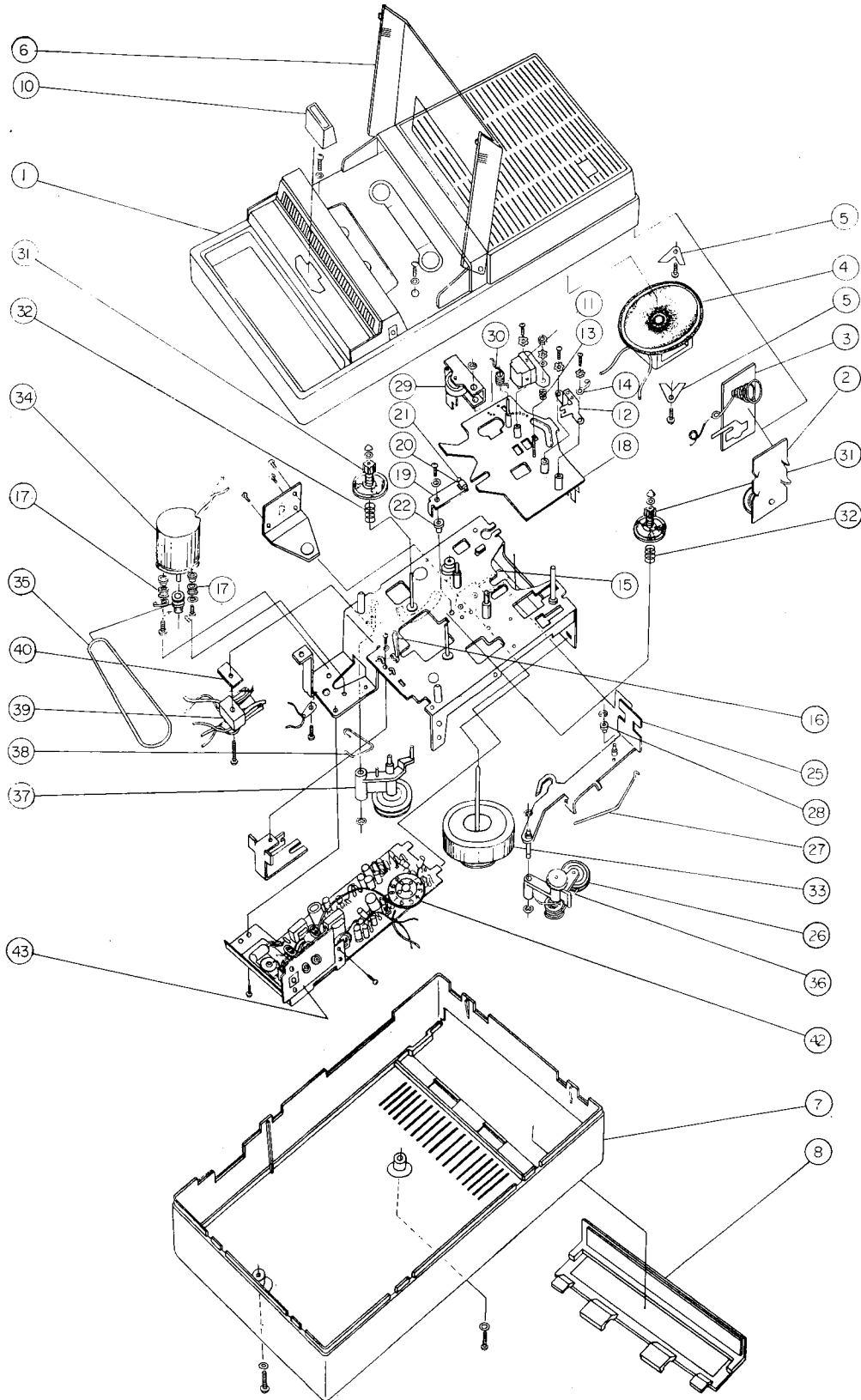

REPLACEMENT PARTS

Symbol No.	Stock No.	Description	Symbol No.	Stock No.	Description
CAPACITORS:					
C 1	0275111	Mylar			0.01 μ F \pm 20%
C 2	0252115	Electrolytic			4.7 μ F
C 3	0252231	Electrolytic			100 μ F
C 4	0252121	Electrolytic			10 μ F
C 5	0252115	Same as C2			
C 6	0275112	Mylar			0.015 μ F \pm 20%
C 7	0252111	Electrolytic			1 μ F
C 8	0252233	Electrolytic			330 μ F
C 9	0252111	Same as C7			
C 10	0252113	Electrolytic			3.3 μ F
C 12	0252221	Electrolytic			10 μ F
C 13	0252231	Same as C3			
C 14	0252332	Electrolytic			220 μ F
C 15	0252332	Same as C14			
C 17	0252232	Electrolytic			220 μ F
C 18	0249513	Ceramic, discal			330pF \pm 10%
RESISTORS:					
R 1	1037951	Carbon film			100k Ω \pm 10%
R 2	0137861	Carbon film			6.8k Ω \pm 10%
R 3	0137861	Same as R2			
R 4	0137855	Carbon film			2.2k Ω \pm 10%
R 5	0137801	Carbon film			100 Ω \pm 10%
R 6	0137959	Carbon film			470k Ω \pm 10%
R 7	0137855	Same as R4			
R 8	0137859	Carbon film			4.7k Ω \pm 10%
R 9	0137853	Carbon film			1.5k Ω \pm 10%
R 10	0137956	Carbon film			270k Ω \pm 10%
R 11	0137759	Carbon film			10 Ω \pm 10%
R 12	0137804	Carbon film			180 Ω \pm 10%
R 13	0137856	Carbon film			2.7k Ω \pm 10%
R 14	0137811	Carbon film			680 Ω \pm 10%
R 15	0137804	Same as R12			
R 16	0137811	Same as R14			
R 17	0137804	Same as R12			
R 18	0137859	Carbon film			4.7k Ω \pm 10%
V R	0151161	Variable			10k Ω (T)
TRANSISTORS:					
Q 1	0573125				2SB75(F)
Q 2	0573481				2SC458(C)
Q 3	0573481	Same as Q2			
Q 4	5320101				2SB156(D)P
Q 5	5320101	Same as Q4			
TH1	0576056	Thermistor			D-1E
TH2	0576056	Same as TH1			
TRANSFORMERS:					
T	0441058	Driver			
for Final assembly					
⑥	6111964	Upper cover			
⑧	6165251	Battery cover ass'y			
⑦	6164873	Bottom case ass'y			
⑩	6260788	Playback knob ass'y			
	0745312	Bind screw-2.6mm ϕ \times 12mm (4 req'd)			
	8815123	Lock washer-2.6mm ϕ (4req'd)			
	8711404	Pan head screw-3mm ϕ \times 4mm			
	8813124	Spring washer-3mm ϕ			
①	6120661	Front case ass'y			
④	0522049	Speaker 3"			
⑤	0680023	Speaker holder			
	8781436	Tapping screw-3mm ϕ \times 6mm (2 req'd) for speaker mounting			
for Chassis assembly					
	7771852	Bind screw with spring washer-2.6mm ϕ \times 4mm (2 req'd) for P.C.B. mounting			
	0711310	Pan head screw-2.6mm ϕ \times 10mm (2 req'd)			
	8811113	Washer-2.6mm ϕ for motor mounting			
⑰	0948783	Rubber plate 8mm ϕ			
	0948808	Collar			
⑪	0513312	Playback head			
⑫	7186531	Tape guide			
	8715104	Pan head screw-2mm ϕ \times 4mm (3 req'd)			
⑬	6310610	Head spring			
	8815121	Lock washer (4 req'd)			
	8812231	Washer-2mm ϕ			
	8821231	Nut-2mm ϕ			
⑲	6310512	Spring for head plate			
⑳	0015595	Roller-5mm ϕ			
㉑	0942042	Roller shaft			
㉒	7501351	Collar for head plate			
	7771855	Bind screw with spring washer-2.6mm ϕ \times 8mm			
㉔	7166441	Function plate ass'y			
㉕	6706743	F.F. arm ass'y			
㉖	0941257	"E" ring 2mm ϕ			
㉗	6310745	Lever spring			
㉘	7505342	Collar			
	0942010	"E" ring			
	7187541	F.R roller stopper			
	0711303	Pan head screw-2.6mm ϕ \times 3mm			
	8811113	Washer-2.6mm ϕ for roller stopper mounting			
㉚	7177321	Pressure roller arm ass'y			
㉛	6310561	Pressure roller spring			
㉜	7662261	Turn table ass'y (A)			
㉝	0662220	Back tension spring			
㉞	0948831	Polyester washer			
㉟	0930002	Cap			
	7771852	Bind screw with spring washer			
	0544186	Lug terminal			
	7179541	Reinforcement plate			
	7174653	Guide plate ass'y			
㊳	6370393	Flywheel ass'y			
	0942094	Flywheel supporting plate ass'y			
	0711304	Pan head screw-2.6mm ϕ \times 4mm (3 req'd)			
㊴	5570291	Micromotor			
㊵	6350141	Belt 1.2 \square			
㊶	7660854	FR belt			
㊷	6709471	Takeup arm ass'y			
㊸	6330173	Takeup arm spring			
㊹	5630223	Arm switch			
㊺	7730602	Switch plate			
	8711110	Pan head screw 2mm ϕ \times 10mm			
for P.C.B. assembly					
	7172423	Jack holder			
J 1	0543082	Jack (red)Mic. jack			
J 2	5670272	JackExternal speaker jack			
J 3	0543113	Jack (B)Remote control jack			
㊻	6701522	Volume control knob			
	8715105	Pan head screw-2mm ϕ \times 5mm			
	8815121	Lock washer-2mm ϕ for knob mounting			
	0941856	Volume cushion			
	5530261	Print P.C.B.			
	0948771	Insulating washer			
	0940826	Radiator plate			
	0645587	Washer			
	0711305	Pan head screw-2.6mm ϕ \times 5mm for transistor mounting			
	0711304	Pan head screw-2.6mm ϕ \times 4mm			
	8811113	Washer-2.6mm ϕ for P.C.B. mounting			
	8715106	Pan head screw-2.6mm ϕ (2 req'd) for jack plate mounting			
	7710721	Insulating fiber			
㊼	6711431	Jack plate			
	7620301	Operating instructions			
	7802616	Carton box			
	7811301	Cushion (right)			
	7811311	Cushion (left)			



Head Office : 4, 1-chome, Marunouchi, Chiyoda-ku, Tokyo
Tel. Tokyo (212) 1111 (80 lines)
Cable Address : "HITACHY" TOKYO
Codes : All Codes Used

Printed in Japan
(NT-H, K)