



Cascade Series

Model Twelve Subwoofer

SERVICE MANUAL



Infinity Systems, Inc.
250 Crossways Park Dr.
Woodbury, New York 11797

Rev1 8/2006

- CONTENTS -

BASIC SPECIFICATIONS	1
DETAILED SPECIFICATIONS.....	2
PACKAGING	4
CONTROLS AND CONNECTIONS.....	5
OPERATION.....	7
EXPLODED VIEW.....	8
TEST SET UP AND PROCEDURE.....	9
BLOCK DIAGRAM.....	10
TROUBLESHOOTING FLOW CHART.....	11
ELECTRICAL PARTS LIST (120v)	12
PCB DRAWINGS.....	18
SEMICONDUCTOR PINOUTS.....	22
SCHEMATICS (120v).....	23

Basic Specifications Cascade Model Twelve Powered Subwoofer

Frequency Response	32Hz – 150Hz (–3dB) 28Hz – 150Hz (–6dB)
Maximum Amplifier Output	300 watts RMS (20Hz – 150Hz, no more than 0.1% THD)
Crossover Frequencies	50Hz – 150Hz, continuously variable or LFE
Drivers	10" (250mm) MMD®, Dual 10" (250mm) MMD passive radiators
Dimensions (H x W x D)	20" x 15" x 13-7/8" (508mm x 381mm x 352mm)
Weight	42 lb (19kg)

Infinity continually strives to update and improve existing products, as well as create new ones. The specifications and construction details in this and related Infinity publications are therefore subject to change without notice.

Cascade Model Twelve subwoofer 300 W Powered Sub/ Plate Amp					
LINE VOLTAGE	Yes/No	Hi/Lo Line	Nom.	Unit	Notes
NA 120vac/60Hz	Yes	108-132	120	Vrms	Normal Operation
EU 230vac/50-60Hz	Yes	207-264	230	Vrms	Normal operation, MOMS required
Parameter	Specification	Unit	QA Test Limits	Conditions	Notes
Amp Section					
Type (Class AB, D, other)	D	---			
Load Impedance (speaker)	4	Ohms		Nominal	Z-curve required
Rated Output Power	300	Watts		Regulated 120 V line	
THD@ Rated Power	1	%		22k filter, 50Hz	300W
THD @ 1 Watt	0.5	%		22k filter, 50Hz	
DC Offset	undefined	mV-DC	< 20	@ Speaker Outputs	
Damping factor	20	N/A	> 15		measured at 50 Hz
Input Sensitivity					
Line Input	260 mV	mVrms		300 W @ 50Hz	1 input driven
Signal to Noise					
SNR-A-Weighted	100	dBA		relative to rated power	A-Weighting filter
SNR-unweighted	70	dBr		relative to rated power	22k filter
SNR rel. 1W-unweighted	60	dBr		relative to 1W Output	22k filter
Residual Noise Floor	2	mVrms		Volume @max, using RMS reading DMM/VOM (or A/P)	
Residual Noise Floor	1	mVrms(max)		Volume @max, w/ A/P Swept Bandpass Measurement (Line freq.+ harmonics)	
Input Impedance					
Line Input	6.5 k	ohms		Nominal	
Active Filters					
Low Pass (fixed or variable)					
Frequency	VARIABLE	--			
Frequency	50 - 150	Hz			
Slope	24	dB/Octave			
Q	Butterworth	--			
High Pass (HPF)					
Frequency	FIXED	--			
Frequency	31	Hz			
Slope	12	dB/Octave			
Q	1.5	--			
Line Out (BUFFERED)					
	STEREO	--			~ Unity Gain
Friend Circuit					
Frequency	FIXED	--			
Frequency	60	Hz		notch filter	
Slope	6	dB/Octave			
Q	2.5	--			
Special filter					
	RABOS	--			
Switches					
Main Power ON/OFF					
	YES	--			
Type	rocker	--		Located on amp plate	TV-5
Rabos ON/OFF					
	YES	--			
Type	mini toggle	--		Located on amp plate	
Line/Spkr Input Select Switch					
	NO	--			
Type	--	--			
Polarity Switch					
	YES	--		"Off": 0°; "On": 180°	
Type	mini toggle	--		Located on amp plate	
Limiter (yes/no)					
	YES	--			compressor and limiter
THD at Max. Output Power	less than 2	%		Maximum Output Power	Maximum THD as a result of limiting.
Output Level Control					
Volume Control Pot					
	YES	--		gain control mounted on amp panel	
Taper (lin/log)	log A taper	--			
@ minimum setting	no output				
Input/Output Configuration					
Line In	Stereo	--		RCA phono jack, gold plated	
LFE In	YES	--		Shared with "R" Line In jack	
Line Outputs (L,R)	YES	--		Buffered all-pass line level L & R	

Parameter	Specification	Unit	QA Test Limits	Conditions	Notes
Signal Sensing (ATO)					
Auto-Turn-On (yes/no)	YES	--			
ATO Input Test Frequency	100	Hz			
ATO Input Threshold	1	mV	typ.		LPF "On", BOS "Off"
ATO Low Pass cutoff	1	kHz	450	ATO-LPF for noise immunity	LPF "On", BOS "Off"
ATO Turn-on time	2	s	10	Amp connected and AC on, then input signal applied (1 W output)	
Auto Mute / Turn-OFF Time	10	minutes	5 < t < 15	Time before muting, after signal is removed	
Power on Features					
Power on Delay time	greater than 2	sec.		AC Power Applied	
Power on LED	YES	--		Bi-color LED located on front of cabinet	
Normal On/Off	green / red	color		ATO mode only	
ATO	--	color		"Active": green; "Standby": red	
Transients/Pops					
ATO Transient	5	mV-peak		@ Speaker Outputs	
Turn-on Transient	30	mV-peak		@ Speaker Outputs	AC Line cycled from OFF to ON
Turn-off Transient	30	mV-peak		@ Speaker Outputs	AC Line cycled from ON to OFF
Efficiency					
Stand-by Input Power	10	Watts	typ.	@ nom. line voltage	
AC Power Cons. @1W	12	Watts	typ.	@ nom. line voltage	
Power Cons. @rated power	473	Watts	typ.	@ nom. line voltage	Input power measured is REAL Watts, not VA
Efficiency	63	%	typ.	@ nom. line voltage	
Protection					
Short Circuit Protection	YES	--		Direct short at output	
Thermal Protection	YES	--		threshold ~ 65 deg. C at panel	
DC Offset Protection	YES	--		DC present at Speaker Out leads	Relay for driver/fire protection
Line Fuse Rating (120 V)	3.15	Amps		Type ADL or MDL	Fuse holder on inside surface of amp panel

MODEL TWELVE PACKAGE

Item#	Description	Part Number	Qty
1	Warranty Card	405-000-05110-E	1
2	Owner's Manual	406-000-05338-E	1
3	Packing Set	431-000-05577-E	1
4	Cotton Packing		1
5	RABOS Kit	373-000-00128-E	1
6	Dessicant		1
7	15" RCA Input Cable	166-015F011-E	1
8	Cardboard Packing		1
9	Outer Carton (Black)	400-000-06653-E	1
	Outer Carton (Silver)	400-000-06655-E	1
	Outer Carton (Cherry)	400-000-06651-E	1

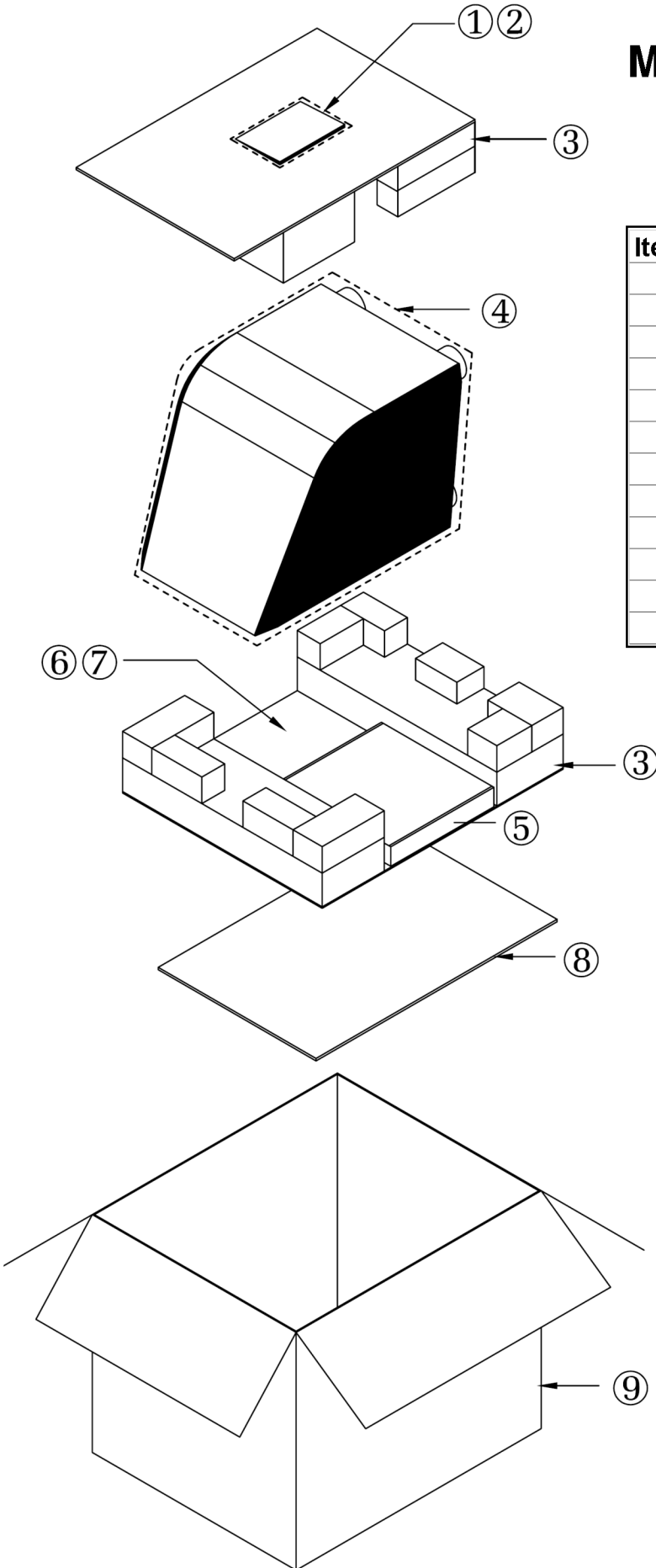

CONTROLS AND CONNECTIONS

Rear Panel

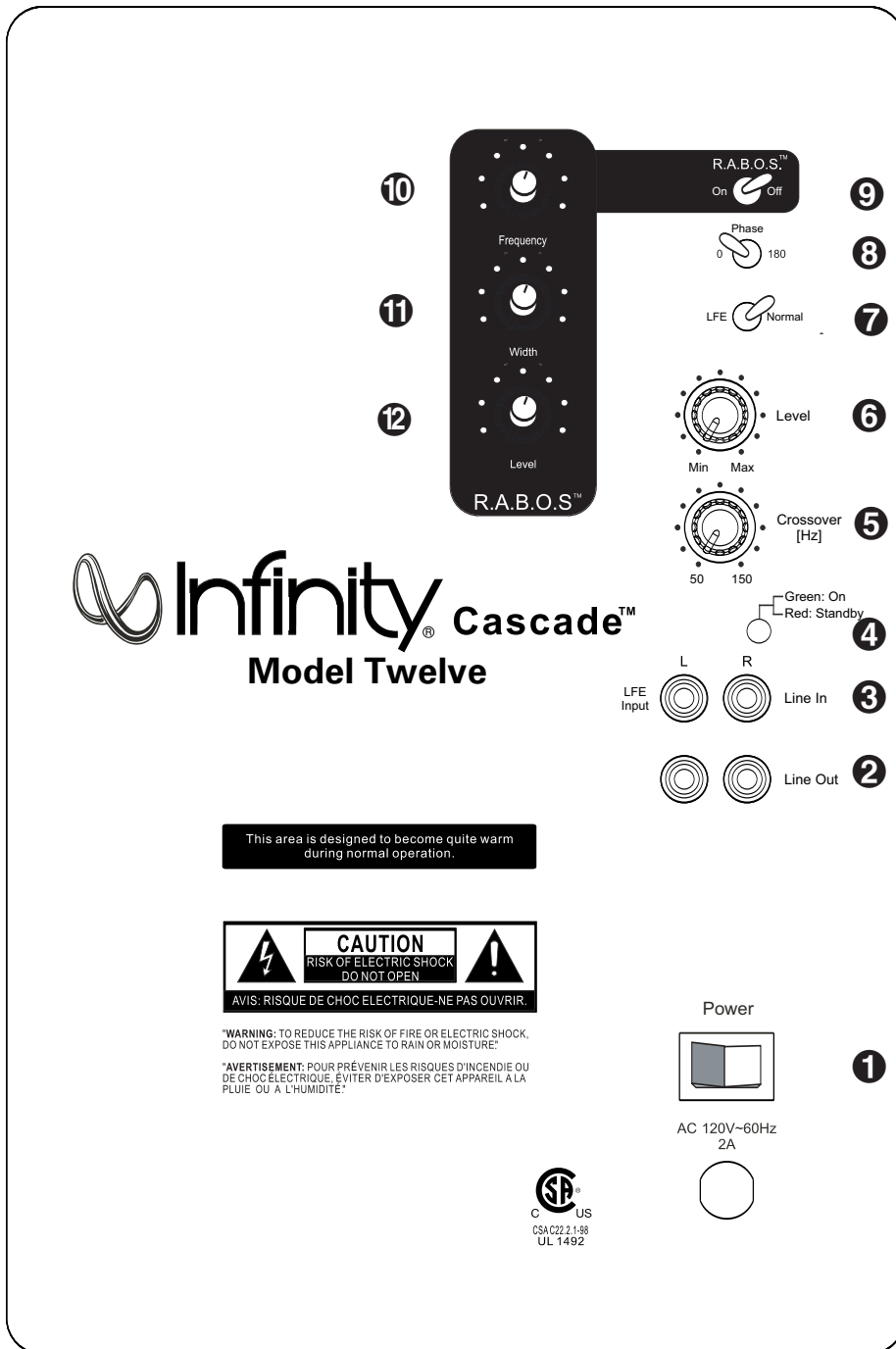

- ❶ Power Switch
- ❷ Line-Level Outputs
- ❸ Line-Level Inputs
- ❹ Power Indicator
- ❺ Crossover Adjustment
- ❻ Subwoofer Level (Volume) Control
- ❼ Normal/LFE Selector
- ❽ Phase Switch
- Bass Optimization Controls** (see page 5)
- ❾ Bass Optimization System Selector
- ❿ Center-Frequency Adjustment
- ⓫ Bass Optimization System Level Adjustment
- ⓬ Bass Optimization System Bandwidth Adjustment

This area is designed to become quite warm during normal operation.

CAUTION
RISK OF ELECTRIC SHOCK
DO NOT OPEN
AVIS: RISQUE DE CHOC ELECTRIQUE-NE PAS OUVRIR.

WARNING: TO REDUCE THE RISK OF FIRE OR ELECTRIC SHOCK, DO NOT EXPOSE THIS APPLIANCE TO RAIN OR MOISTURE.
*AVERTISSEMENT: POUR PREVENIR LES RISQUES D'INCENDIE OU DE CHOC ELECTRIQUE, EVITER D'EXPOSER CET APPAREIL A LA PLUIE OU A L'HUMIDITE'.

SP
C US
CSAC221.1-08
UL 1492

Power

AC 120V~60Hz
2A

CONNECTIONS

If you have a Dolby® Digital or DTS® receiver/processor with a low-frequency-effects (LFE) output:

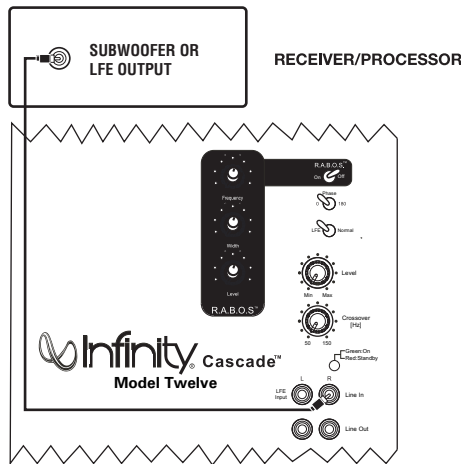

- Set Normal/LFE Switch to LFE.

NOTE: In this case, you do not need to use a Y connector. Simply connect the LFE output on your receiver/processor to either the left or right input on the subwoofer.

If your receiver/processor has subwoofer outputs for the left and right channels:

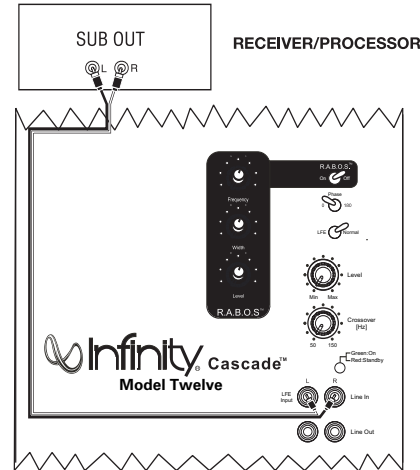

- Set Normal/LFE Switch to Normal.

NOTE: Some receivers have a single subwoofer output (do not confuse this with a single LFE output as described to the left). In that case, it is recommended that you use a Y connector (not included) to maximize performance.

The Cascade Model Twelve also includes a set of line outputs. These outputs allow you to “daisy-chain” one Model Twelve to multiple Model Twelve subwoofers. Simply connect the first subwoofer as described above and then run a subwoofer cable from the line output(s) to the line input(s) on the next sub.

NOTE: This line output is before the R.A.B.O.S. circuit. Each subwoofer’s R.A.B.O.S. controls must be individually adjusted during the R.A.B.O.S. setup.

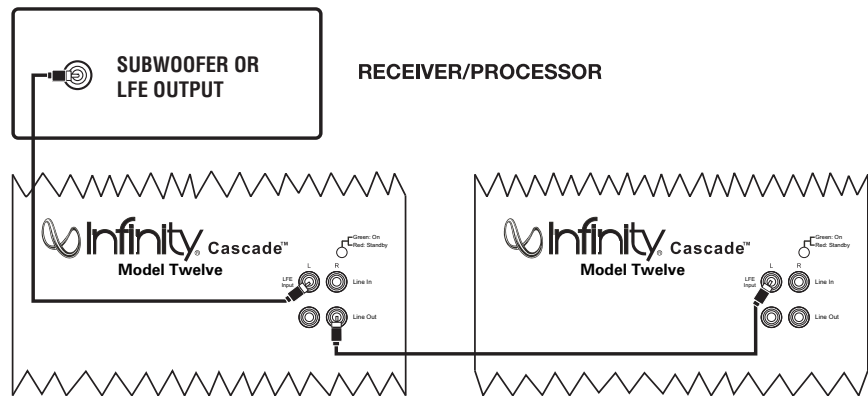

OR

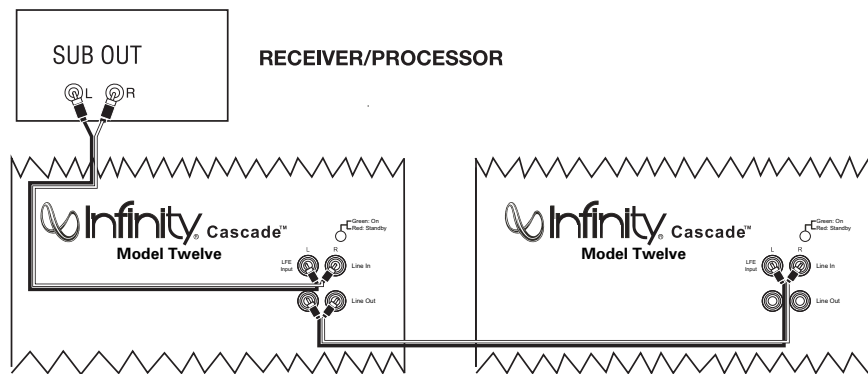

OPERATION

Power On

Plug your subwoofer's AC cord into a wall outlet. Do not use the outlets on the back of the receiver.

Initially set the Subwoofer Level (Volume) Control **6** to the "min" position.

Turn on your sub by pressing the Power Switch **1** on the rear panel.

Auto On/Standby

With the Power Switch **1** in the ON position, the Power Indicator LED **4** will remain backlit in red or green to indicate the On/Standby mode of the subwoofer.

RED = STANDBY (No signal detected, Amp Off)

GREEN = ON (Signal detected, Amp On)

The subwoofer will automatically enter the Standby mode after approximately 10 minutes when no signal is detected from your system. The subwoofer will then power ON instantly when a signal is detected. During periods of normal use, the Power Switch **1** can be left on. You may turn off the Power Switch **1** for extended periods of nonoperation, e.g., when you are away on vacation.

Adjust Gain

Turn on your entire audio system and start a CD or movie soundtrack at a moderate level. Turn up the Subwoofer Level (Volume) Control **6** about half way. If no sound emanates from the subwoofer, check the AC-line cord and input cables. Are the connectors on the cables making proper contact? Is the AC plug connected to a "live" receptacle? Has the Power Switch **1** been pressed to the "On" position? Once you have confirmed that the subwoofer is active, proceed by playing a CD, record or cassette. Use a selection that has ample bass information.

Set the overall volume control of the preamplifier or stereo to a comfortable level. Adjust the Subwoofer Level (Volume) Control **6** until you obtain a pleasing blend of bass. Bass response should not overpower the room but rather be adjusted so there is a harmonious blend across the entire musical range. Many users have a tendency to set the subwoofer volume too loud, adhering to the belief that a subwoofer is there to produce lots of bass. This is not entirely true. A subwoofer is there to enhance bass, extending the response of the entire system so the bass can be felt as well as heard. However, overall balance must be maintained or the music will not sound natural. An experienced listener will set the volume of the subwoofer so its impact on bass response is always there but never obtrusive.

Crossover Adjustments

NOTE: This control will have no effect if the Normal/LFE Selector Switch **7** is set to "LFE." If you have a Dolby Digital or DTS processor/receiver, the Crossover Frequency is set by the processor/receiver. Consult your owner's manual to learn how to view or change this setting.

The Crossover Adjustment Control **5** determines the highest frequency at which the subwoofer reproduces sounds. If your main speakers can comfortably reproduce some low-frequency sounds, set this control to a lower frequency setting, between 50Hz and 100Hz. This will concentrate the subwoofer's efforts on the ultradeep bass sounds required by today's films and music. If you are using smaller bookshelf speakers that do not extend to the lower bass frequencies, set the Crossover Adjustment Control to a higher setting, between 120Hz and 150Hz.

Phase Control

The Phase Switch **3** determines whether the subwoofer speaker's piston-like action moves in and out with the main speakers, 0° or opposite the main speakers, 180°. Proper phase adjustment depends on several variables such as room size, subwoofer placement and listener position. Adjust the phase switch to maximize bass output at the listening position.

MODEL TWELVE EXPLODED VIEW

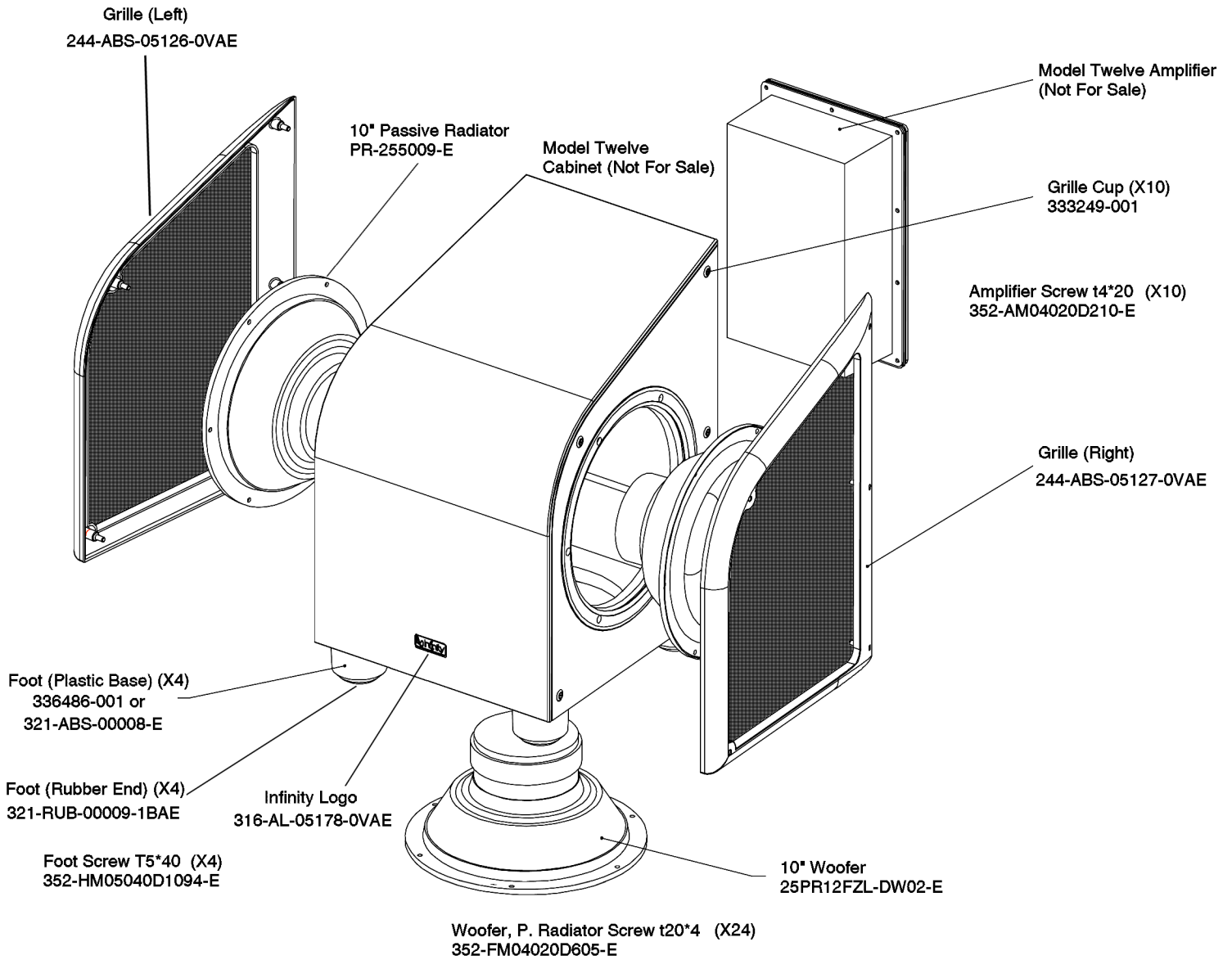

Cascade Model Twelve TEST PROCEDURE

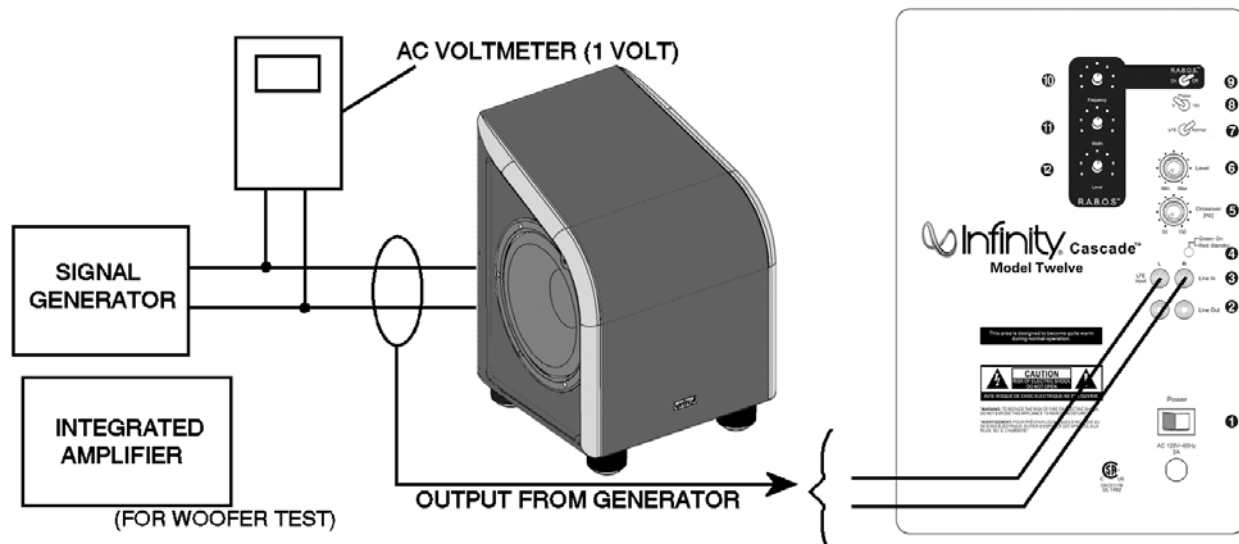

The operation of the Cascade Model Twelve subwoofer, and the proper settings for the Room Adaptive Bass Optimization System, or R.A.B.O.S., is thoroughly covered in the Owner's guide, part# 406-000-05338-E. For service purposes, the R.A.B.O.S. system is canceled when all three front panel controls (F) (L) (W) are turned fully CW (Clockwise), or if the R.A.B.O.S. On/Off switch is OFF. The only other control of concern is the Main Level Control on the front panel, which operates like a traditional potentiometer.

Equipment needed:

- Function/signal generator/sweep generator
- Integrated Amplifier
- Multimeter
- RCA cables; Speaker cables

General Unit Function (UUT = Unit Under Test)

Switch/Controls:

MAIN LEVEL control full Counterclockwise (Min)
 CROSSOVER (Hz) Full Clockwise (150)
 R.A.B.O.S. On/Off switch OFF
 PHASE switch - either position
 (3) R.A.B.O.S. controls – do not matter

- 1) From the signal generator, connect one line level (RCA) cable to the Line In jacks (L/R) on the UUT. Use a Y-cable from a mono source if necessary to connect to both inputs.
- 2) Turn on generator; adjust to **150mV, 50 Hz**.
- 3) Plug AC power cord in UUT, turn power switch ON.
- 4) LED should be ON (faceplate). Turn up LEVEL control to full Clockwise (Max).
- 5) LED should be Green; Bass response should be heard and felt from woofer at bottom of cabinet.
- 6) Turn LEVEL control full Counterclockwise (Min). Turn power switch OFF.

Sweep Function

- 1) Follow steps 1-5 above, using a sweep generator as a signal source – adjust the generator to **100mV, 50 Hz**.
- 2) Sweep generator from 20Hz to 300Hz. Listen for any rattles, clicks, buzzes or any other noises. If any unusual noises are heard, test woofer according to the instructions below.

Driver Function

- 1) Remove woofer from the enclosure. Check DC resistance of woofer; it should be **3.4Ω ±10%**,
- 2) Connect a pair of speaker cables to woofer terminals. Cables should be connected to an integrated amplifier fed by a signal generator. Turn on generator and adjust so that speaker level output is **6.0V**.
- 3) Sweep generator from 20Hz to 1kHz. Listen to driver for any rubbing, buzzing, or other unusual noises.

BLOCK DIAGRAM

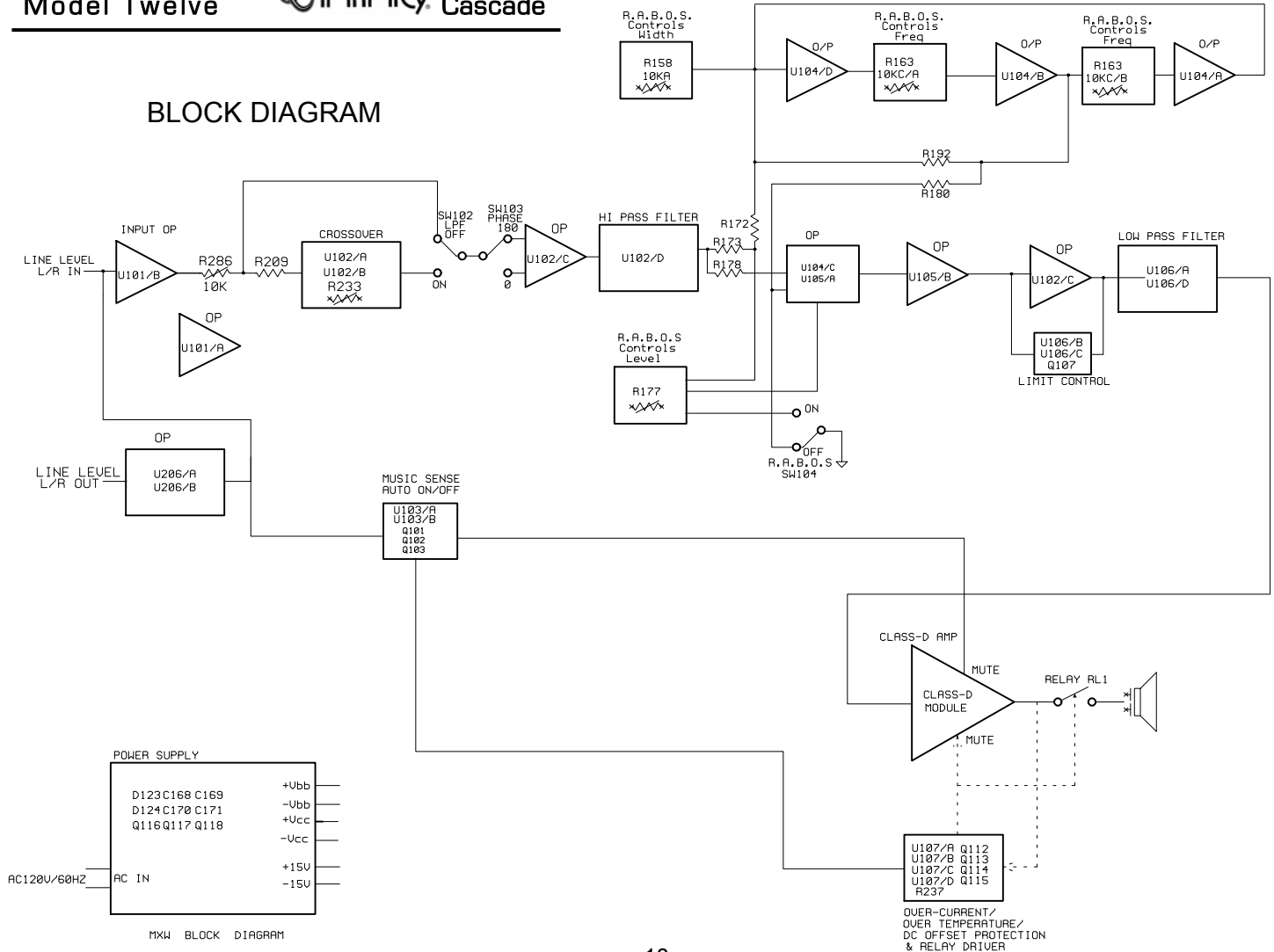

MXW BLOCK DIAGRAM

OVER-CURRENT /
OVER-TEMPERATURE /
DC-OFF-SET PROTECTION
& RELAY DRIVER

MODEL12 Test Flow Chart

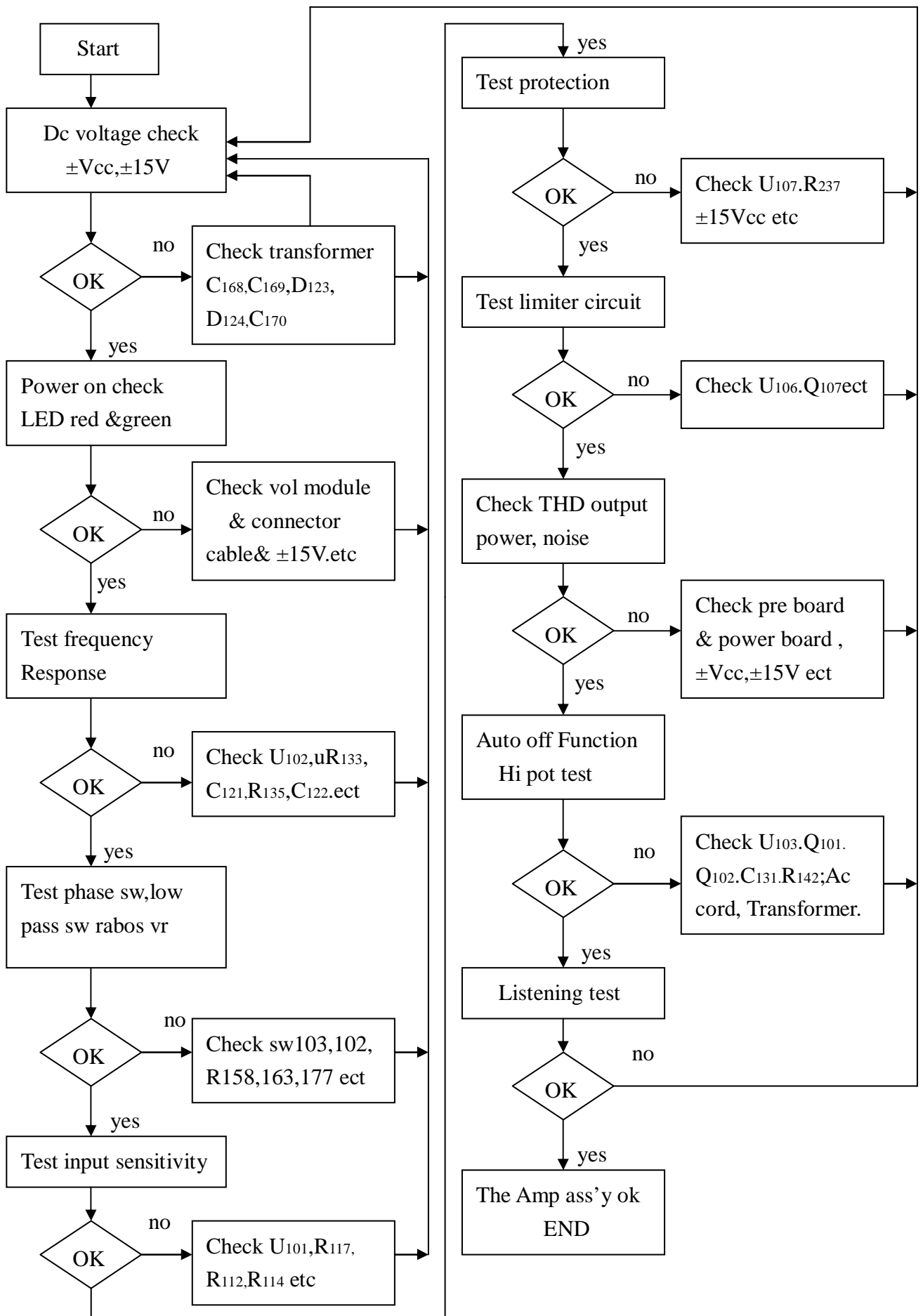

Cascade Model Twelve Electrical Parts List 120v			
Part Number	Description	Q'ty	Reference Designator
MAIN/POWER SUPPLY PCB			
<i>Resistors</i>			
110-16102j26-e	CARBON RESISTOR 1K 1/6W ±5% CF 26mm (RoHS)	3	R210,R239,R264
110-16103j26-e	CARBON RESISTOR 10K 1/6W ±5% CF 26mm (RoHS)	9	R216,R227,R229,R230,R231,R232,R233,R260,R261
110-16153j26-e	CARBON RESISTOR 15K 1/6W ±5% CF 26mm (RoHS)	2	R247,R249
110-16182j26-e	CARBON RESISTOR 1.8K 1/6W ±5% CF 26mm (RoHS)	1	R248
110-16222j26-e	CARBON RESISTOR 2.2K 1/6W ±5% CF 26mm (RoHS)	2	R242,R245
110-16223j26-e	CARBON RESISTOR 22K 1/6W ±5% CF 26mm (RoHS)	3	R218,R220,R223
110-16274j26-e	CARBON RESISTOR 270K 1/6W ±5% CF 26mm (RoHS)	1	R240
110-16333j26-e	CARBON RESISTOR 33K 1/6W ±5% CF 26mm (RoHS)	1	R211
110-16391j26-e	CARBON RESISTOR 390Ω 1/6W CF 26mm (RoHS)	2	R243,R246
110-16472j26-e	CARBON RESISTOR 4.7K 1/6W ±5% CF 26mm (RoHS)	4	R213,R217,R219,R222
110-16473j26-e	CARBON RESISTOR 47K 1/6W ±5% CF 26mm (RoHS)	1	R221
110-16683j26-e	CARBON RESISTOR 68K 1/6W ±5% CF 26mm (RoHS)	1	R212
112-14101j26-e	FUSE RESISTOR 1/4W 100ohm 5%(RoHS)	2	R241,R244
116-141r00j26x-e	MTL FILM RESISTOR 1.00Ω 1/4W ±5% MO 26mm (RoHS)	2	R255,R256
116-161002f26-e	MTL FILM RESISTOR 10K 1/6W ±1% MF 26mm (RoHS)	2	R234,R235
116-161301f26-e	MTL FILM RESISTOR1.30K 1/6W MF 26mm (RoHS)	3	R226,R228,R236
116-161692f26-e	MTL FILM RESISTOR16.9K 1/6W MF 26mm (RoHS)	1	R214
116-162001f26-e	MTL FILM RESISTOR 2.00K 1/6W ±1% MF 26mm (RoHS)	1	R215
116-162492f26-e	MTL FILM RESISTOR 24.9K 1/6W ±1% MF 26mm (RoHS)	2	R257,R258
116-166813f26-e	MTL FILM RESISTOR 681K 1/6W ±1% MF 26mm (RoHS)	1	R262
110-12621j15-e	CARBON RESISTOR 620Ω 1/2W ±5% 15mm(RoHS)	1	R238
110-20152j20-e	CARBON RESISTOR 1.5K 2W ±5% CF 20mm KINK(RoHS)	1	R208
113-500r1j10-e	CEMENT RESISTOR 0.1Ω 5W ±5% (RoHS)	2	R224,R225
116-142003f26-e	MTL FILM RESISTOR 200K 1/4W ±1% MF 26mm (RoHS)	1	R209
<i>Capacitors</i>			
130-2b102k503-e	DISC CAPACITOR 1000P 50V ±10% (RoHS)	1	C165
130-3f104z503-e	DISC CAPACITOR 0.1U 50V +80/-20% (RoHS)	2	C163,C164
130-ch101j503-e	DISC CAPACITOR 100P 50V ±5% (RoHS)	2	C159,C160
135-3107m16-e	ELECTROLYTIC CAP 100uF 16V ±20% (RoHS)	2	C166,C167
135-3226m50-e	ELECTROLYTIC CAP 22U 50V ±20% (RoHS)	2	C161,C162
135-3227m10-e	ELECTROLYTIC CAP 220U 10V ±20% (RoHS)	2	C156,C157
139-3227m16-e	LOW LEAKAGE EC 220uF 16V ±20% (RoHS)	1	C155
140-rx103ka03-e	MULTY LAYER CAP 10nF 100V X7R 10%(RoHS)	1	C174
140-rx473kb03-e	MULTY LAYER CAP 47NF 200V X7R ±10% (RoHS)	2	C172,C173
135-4228m35-e	ELECTROLYTIC CAP 2200uF 35V ±20%(RoHS)	2	C170,C171
135-4688m80-e	ELECTROLYTIC CAP 6800U 80V ±20%(RoHS)	2	C168,C169
<i>Semiconductors</i>			
190-161431clp1-e	IC TL431CLP(RoHS) Adjustable precision shunt regulator	1	D115
192-027c1815gr-e	TRANSISTOR 2SC1815GR (RoHS) NPN	4	Q110,Q112,Q114,Q117
192-028a1015gr-e	TRANSISTOR 2SA1015GR (RoHS) PNP	3	Q111,Q113,Q115
192-1572n5551-e	TRANSISTOR FSC 2N5551 (RoHS) NPN	1	Q109
192-1582n5401-e	TRANSISTOR FSC 2N5401 AI-PNP 350V 500mA TO-92(RoHS)	1	Q108
197-031n4148-e	DIODE 100mA 75V SIGNAL 1N4148 ROHM (RoHS)	7	D117,D118,D119,D120,D121,D125,D126
199-15000565-e	ZENER DIODE 5.6V 1/2W 52mm (RoHS)	1	D116
199-15001505-e	ZENER DIODE 15V 1/2W 52mm (RoHS)	1	D122

Part Number	Description	Q'ty	Reference Designator
MAIN/POWER SUPPLY PCB			
199-15002005-e	ZENER DIODE 20V 1/2W 52mm (RoHS)	1	D129
109-1tsc103j0-e	THERMISTOR TSC05103J(RoHS)	1	R237
190-16lm324n-e	I.C. LM324N(RoHS) DUAL OP-AMP	1	U107
192-991d669a-e	TRANSISTOR HI-SINCERITY HSD669A(RoHS) NPN	1	Q116
192-992b649t-e	TRANSISTOR HSB649T(RoHS) PNP	1	Q118
197-00db103g-e	DIODE 1A 200V DF02M DB103G(RoHS) BRIDGE	1	D124
197-00kbu1003-e	DIODE 10A 200V BRIDGE	1	D123
197-101n4002-e	DIODE 1N4002 (RoHS)	1	D114
<i>Miscellaneous</i>			
171-udhss124d-e	RELAY 5A 24V UDH-SS124D(RoHS)	1	K101
175-1c02p01-e	WIRE CONNECTOR&BASE 2PIN PITCH=2.5mm(RoHS)	1	P108
175-1c06v01-e	WIRE CONNECTOR&BASE 6 PIN PITCH=2.5mm(RoHS)	1	P107
175-1d02v01-e	WIRE CONNECTOR&BASE 2PIN PITCH=3.96mm(RoHS)	1	P112
175-1d05v01-e	WIRE CONNECTOR&BASE 5PIN 3.96mm(RoHS)	1	P113
PREAMP PCB			
<i>Resistors</i>			
110-14152j26-e	CARBON RESISTOR 1.5K 1/4W ±5% CF 26mm (RoHS)	1	R150
110-16101j26-e	CARBON RESISTOR 100Ω 1/6W ±5% CF 26mm (RoHS)	4	R112,R113,R151,R152
110-16102j26-e	CARBON RESISTOR 1K 1/6W ±5% CF 26mm (RoHS)	1	R140
110-16103j26-e	CARBON RESISTOR 10K 1/6W ±5% CF 26mm (RoHS)	7	R263,R118,R133,R136,R146,R149,R199
110-16105j26-e	CARBON RESISTOR 1M 1/6W ±5% CF 26mm (RoHS)	2	R145,R181
110-16151j26-e	CARBON RESISTOR 150Ω 1/6W ±5% CF 26mm (RoHS)	1	R139
110-16183j26-e	CARBON RESISTOR 18K 1/6W ±5% CF 26mm (RoHS)	1	R147
110-16203j26-e	CARBON RESISTOR 20K 1/6W ±5% CF 26mm (RoHS)	1	R200
110-16221j26-e	CARBON RESISTOR 220Ω 1/6W ±5% CF 26mm (RoHS)	2	R119,R120
110-16223j26-e	CARBON RESISTOR 22K 1/6W ±5% CF 26mm (RoHS)	2	R141,R148
110-16274j26-e	CARBON RESISTOR 270K 1/6W ±5% CF 26mm (RoHS)	1	R138
110-16331j26-e	CARBON RESISTOR 330Ω 1/6W ±5% CF 26mm (RoHS)	2	R284,R285
110-16432j26-e	CARBON RESISTOR 4.3K 1/6W ±5% CF 26mm (RoHS)	1	R254
110-16472j26-e	CARBON RESISTOR 4.7K 1/6W ±5% CF 26mm (RoHS)	1	R144
110-16473j26-e	CARBON RESISTOR 47K 1/6W ±5% CF 26mm (RoHS)	1	R137
110-16474j26-e	CARBON RESISTOR 470K 1/6W ±5% CF 26mm (RoHS)	1	R143
110-164r7j26-e	CARBON RESISTOR 4.7Ω 1/6W ±5% CF 26mm (RoHS)	1	R153
110-16621j26-e	CARBON RESISTOR 620Ω 1/6W ±5% CF 26mm (RoHS)	2	R287,R288
116-161001f26-e	MTL FILM RESISTOR 1K 1/6W ±1% MF26mm (RoHS)	1	R194
116-161002f26-e	MTL FILM RESISTOR 10K 1/6W ±1% MF 26mm (RoHS)	3	R130,R131,R132
116-161504f26-e	MTL FILM RESISTOR 1.5M 1/6W ±1% MF 26mm (RoHS)	1	R142
116-161693f26-e	MTL FILM RESISTOR 169K 1/6W ±1% MF 26mm (RoHS)	1	R195
116-162001f26-e	MTL FILM RESISTOR 2.00K 1/6W ±1% MF 26mm (RoHS)	1	R202
116-162052f26-e	MTL FILM RESISTOR 20.5K 1/6W ±1% MF 26mm (RoHS)	2	R197,R198
116-162212f26-e	MTL FILM RESISTOR 22.1K 1/6W ±1% MF 26mm (RoHS)	3	R193,R204,R206
116-162262f26-e	MTL FILM RESISTOR 22.6K 1/6W ±1% MF 26mm (RoHS)	4	R209,R231,R232,R296
116-163322f26-e	MTL FILM RESISTOR 33.2K 1/6W ±1% MF 26mm (RoHS)	2	R220,R225
116-163923f26-e	MTL FILM RESISTOR 392K 1/6W ±1% MF 26mm (RoHS)	1	R201
116-164320f26-e	MTL FILM RESISTOR 432Ω 1/6W ±1% MF 26mm (RoHS)	1	R265
116-164421f26-e	MTL FILM RESISTOR 4.42K 1/6W ±1% MF 26mm (RoHS)	2	R205,R207
116-164751f26-e	MTL FILM RESISTOR 4.75K 1/6W MF 26mm (RoHS)	2	R109,R110
116-164752f26-e	MTL FILM RESISTOR 47.5K 1/6W ±1% MF 26mm (RoHS)	2	R121,R122

Part Number	Description	Q'ty	Reference Designator
PREAMP PCB			
116-166491f26-e	MTL FILM RESISTOR 6.49K 1/6W ±1% MF 26mm (RoHS)	2	R114,R115
116-166812f26-e	MTL FILM RESISTOR 68.1K 1/6W ±1% MF 26mm (RoHS)	1	R135
116-168061f26-e	MTL FILM RESISTOR 8.06K 1/6W ±1% MF 26mm (RoHS)	1	R134
115-h103a101-e	VARIABLE RESISTOR A10K (RoHS)	1	R286
115-h503b405-e	VARIABLE RESISTOR B50K (RoHS) 4 GANG	1	R233
<i>Capacitors</i>			
129-a104j633-e	MTLIZE CAP 0.1U 63V ±5% MSC (RoHS)	3	C137,C138,C139
129-a224j633-e	MTLIZE CAP 0.22uF 63V ±5% MSC (RoHS)	2	C121,C122
129-a333j633-e	MTLIZE CAP 0.033U 63V MSC (RoHS)	2	C209,C218
129-a473j633-e	MTLIZE CAP 0.047U 63V ±5% MSC (RoHS)	1	C149
129-a683j633-e	MTLIZE CAP 0.068uF 63V ±5% MSC (RoHS)	2	C201,C213
130-2b102k503-e	DISC CAPACITOR 1000P 50V ±10% (RoHS)	2	C181,C182
130-2b221k503-e	DISC CAPACITOR 220P 50V ±10% (RoHS)	5	C107,C108,C110,C228,C231
130-3f104z503-e	DISC CAPACITOR 0.1U 50V +80/-20% (RoHS)	11	C112,C114,C124,C125,C130,C133,C135,C153,C154,C232,C233
130-3f473m503-e	DISC CAPACITOR 0.047U 50V ±20% (RoHS)	1	C180
130-sl101k503-e	DISC CAPACITOR 100P 50V SL ±10% (RoHS)	2	C120,C148
130-sl470k503-e	DISC CAPACITOR 47P 50V ±10% (RoHS)	1	C128
135-3105m50-e	ELECTROLYTIC CAP 1U 50V ±20% (RoHS)	1	C126
135-3106m50-e	ELECTROLYTIC CAP 10uF 50V ±20% (RoHS)	4	C109,C111,C123,C129
135-3107m16-e	ELECTROLYTIC CAP 100uF 16V ±20% (RoHS)	5	C113,C115,C132,C134,C136
135-3107m25-e	ELECTROLYTIC CAP 100U 25V ±20% (RoHS)	1	C152
135-3226m50-e	ELECTROLYTIC CAP 22U 50V ±20% (RoHS)	1	C151
139-3227m16-e	LOW LEAKAGE EC 220uF 16V ±20% (RoHS)	1	C131
129-a223j633-e	MTLIZE CAP 0.022U 63V ±5% MSC (RoHS)	1	C150
<i>Semiconductors</i>			
192-027c1815gr-e	TRANSISTOR 2SC1815GR (RoHS) NPN	3	Q101,Q102,Q103
197-031n4148-e	DIODE 100mA 75V SIGNAL 1N4148 ROHM (RoHS)	7	D105,D106,D108,D109,D110,D112,D113
199-15000825-e	ZENER DIODE 8.2V 1/2W 52mm (RoHS)	1	D130
190-06m4558d-e	I.C. OPA 4558D (RoHS) DUAL OP-AMP	1	U101,U103
190-16t072n-e	I.C. TL072N @6.5 (RoHS) DUAL OP-AMP	2	U206
190-16t074cn-e	I.C TL074CN ST (RoHS) QUAD OP-AMP	2	U102,U106
192-153mpf102-e	TRANSISTOR FAIRCHILD MPF102 (RoHS) FET	1	Q107
195-10107egw-e	L.E.D φ5 HL-50107EGW (RoHS)	1	D201
<i>Miscellaneous</i>			
162-10169003-e	WIRE 160mm AWG28 WHT/BLK (RoHS)	1	P105
162-a013d001-e	WIRE UL1007#28 130mm WHT/BLK (RoHS)	1	P104A
174-0rcb204vg-e	RCA-204VG(GOLDEN) (RoHS)	1	JK102
175-1c02p01-e	WIRE CONNECTOR&BASE 2PIN PITCH=2.5mm (RoHS)	1	P106
175-9c08v01-e	WIRE CONNECTOR&BASE 8PIN PITCH=2.5mm (RoHS)	1	P104
180-t000ts81-e	TACT SWITCH L101 (RoHS) PHASE,LFE,RABOS	3	SW102,SW103,SW104
RABOS PCB			
<i>Resistors</i>			
110-16105j26-e	CARBON RESISTOR 1M 1/6W ±5% CF 26mm TAP (RoHS)	1	R181

Part Number	Description	Q'ty	Reference Designator
RABOS PCB			
110-16106j26-e	CARBON RESISTOR 10M 1/6W ±5% CF 26mm TAP (RoHS)	1	R186
116-161000f26-e	METAL FILM RESISTOR 100Ω 1/6W ±1% MF 26mm TAP (RoHS)	1	R154
116-161001f26-e	METAL FILM RESISTOR 1K 1/6W ±1% MF 26mm TAP (RoHS)	1	R180,R187,R252
116-161002f26-e	METAL FILM RESISTOR 10K 1/6W ±1% MF 26mm TAP (RoHS)	8	R171,R159,R160,R166,R192,R173,R178
116-161103f26-e	METAL FILM RESISTOR 110K ±1% MF 1/6W 26mm TAP (RoHS)	1	R174
116-161502f26-e	METAL FILM RESISTOR 15.0K 1/6W ±1% MF 26mm TAP (RoHS)	2	R162,R168
116-161652f26-e	METAL FILM RESISTOR 16.5K 1/6W ±1% MF 26mm TAP (RoHS)	1	R188
116-162051f26-e	METAL FILM RESISTOR 2.05K 1/6W MF 26mm TAP (RoHS)	1	R253
116-162211f26-e	METAL FILM RESISTOR 2.21K 1/6W ±1% MF 26mm TAP (RoHS)	1	R172
116-162671f26-e	METAL FILM RESISTOR 2.67K 1/6W ±1% MF 26mm TAP (RoHS)	1	R155
116-163161f26-e	METAL FILM RESISTOR 3.16K 1/6W MF 26mm TAP ±1% (RoHS)	1	R251
116-163400f26-e	METAL FILM RESISTOR 340Ω 1/6W ±1% MF 26mm TAP (RoHS)	2	R164,R169
116-163571f26-e	METAL FILM RESISTOR 3.57K 1/6W 1% MF 26mm TAP (RoHS)	1	R157
116-165400f26-e	METAL FILM RESISTOR 540Ω 1/6W MF 26mm TAP (RoHS)	1	R175
116-166041f26-e	METAL FILM RESISTOR 6.04K 1/6W ±1% MF TAP 26mm (RoHS)	2	R165,R170
116-166341f26-e	METAL FILM RESISTOR 6.34K 1/6W±1%MF (RoHS)	1	R189
116-166800f26-e	METAL FILM RESISTOR 680Ω 1/6W ±1% MF 26mm TAP (RoHS)	1	R176
116-168250f26-e	METAL FILM RESISTOR 825Ω 1/6W ±1% MF 26mm TAP (RoHS)	2	R161,R167
116-169092f26-e	METAL FILM RESISTOR 90.9K 1/6W MF 26mm TAP (RoHS)	1	R190
116-169311f26-e	METAL FILM RESISTOR 9.31K 1/6W ±1% MF 26mm TAP (RoHS)	1	R179
115-h103c201-e	VAR RESISTOR RV16A01-20-15K-C10K-3E (RoHS) FREQ	1	R163
115-h103a203-e	VAR RESISTOR RV16A01-20-15K-A10K-3E (RoHS) LEVL,WIDTH	2	R158,R177
<i>Capacitors</i>			
129-a104j633-e	METALIZE CAP 0.1U 63V ±5% MSC TAP (RoHS)	3	C138,C139,C137
129-a683j633-e	METALIZE CAP 0.068uF 63V ±5% MSC TAP (RoHS)	2	C142,C143
130-3f104z503-e	DISC CAPACITOR 0.1U 50V +80/-20% TAP (RoHS)	4	C144,C145,C146,C147
<i>Semiconductors</i>			
190-16t072n-e	I.C. TL072N @6.5 (RoHS) DUAL OP-AMP	1	U105
190-16t074cn-e	I.C TL074CN ST (RoHS) QUAD OP-AMP	1	U104
CLASS D PCB ASS'Y (RECOMMENDED REPLACE ENTIRE MODULE PART# 051-A05022C-E)			
<i>Resistors</i>			
112-10180j00-e	FUSE RESISTOR FMF 1W 18Ω 5%(RoHS)	1	
118-12061001f-e	SMD RESISTOR 1K 1206 1%(RoHS)	1	R2
118-12061002f-e	SMD RESISTOR 10K 1206 1%(RoHS)	1	R25
118-12061002j-e	SMD RESISTOR 10.0K 1206 5%(RoHS)	5	R29,R30,R30B,R7,R9
118-120610r0j-e	SMD RESISTOR 10.0Ω 1206 5%(RoHS)	4	R20,R20B,R22,R23
118-12062002f-e	SMD RESISTOR 20K 1206 1%(RoHS)	1	R26
118-12062201j-e	SMD RESISTOR 2.20K 1206 5%(RoHS)	18	R13,R16,R31,R33,R34,R35,R36,R37,R38,R39,R40,R41,R42,R43,R44,R45,R46,R32
118-12062204j-e	SMD RESISTOR 2.20M 1206 5% (RoHS)	1	R4
118-12062211f-e	SMD RESISTOR 2.21K 1206 1% (RoHS)	1	R6
118-12062550f-e	SMD RESISTOR 1206 255Ω 1%(RoHS)	1	R24
118-12062701j-e	SMD RESISTOR 2.70K 1206 5%(RoHS)	1	R10
118-12063301j-e	SMD RESISTOR 3.30K 1206 5%(RoHS)	4	R14,R15,R27,R28
118-12063321f-e	SMD RESISTOR 3.32K 1206 1%(RoHS)	1	R1
118-12063922f-e	SMD RESISTOR 1206 39.2K±1%(RoHS)	1	R3

Part Number	Description	Q'ty	Reference Designator
CLASS D PCB ASS'Y (RECOMMENDED REPLACE ENTIRE MODULE PART# 051-A05022C-E)			
118-12064700j-e	SMD RESISTOR 470Ω 1206 5%(RoHS)	3	R8,R11,R21
118-12064701j-e	SMD RESISTOR 4.70K 1206 5%(RoHS)	1	R12
118-12064751f-e	SMD RESISTOR 4.75K 1206 1%(RoHS)	1	R5
<i>Capacitors</i>			
130-sl681kb03-e	DISC CAPACITOR SL 680PF 200V(RoHS)	1	
132-104kb50-e	MYLAR CAPACITOR 0.1U ±10% 250V LS-10.mm MD (RoHS)	1	C20
132-105kb50-e	MYLAR CAPACITOR 1uF 250V ±10% (RoHS)	1	C40
128-e106ma01-se	CROSSVER CAP 10uF 100V 20% (RoHS)	2	C16,C17
141-c0101k50-e	SMD CAPACITOR 100pF 50V 10% 1206 NPO(RoHS)	1	C4
141-c0220k50-e	SMD CAPACITOR 22pF 50V 10% 1206 SMT NPO(RoHS)	1	C5
141-c0561k50-e	SMD CAPACITOR 560pF 50V 10% 1206 NPO(RoHS)	1	C6
141-c5104m50-e	SMD CAPACITOR 1206 Y5V 0.1uF 50V ±20%(RoHS)	8	C2,C3,C7,C8,C9,C10,C11,C15
141-c7103k50-e	SMD CAPACITOR 0.01uF 50V 10% 1206 X7R(RoHS)	1	C13
141-d7104ka0-e	SMD CAPACITOR 0.1uF 100V 10% 1210 X7R(RoHS)	4	C12,C14,C18,C19
<i>Semiconductors</i>			
190-16tl072dts-e	SMD I.C. TL072CDT SGS THOMSON(RoHS)	1	IC1
192-09124126qs-e	SMD TRANSISTOR 2SC2412K-T146Q/R ROHM(RoHS)	2	Q1,Q4
192-09139066rs-e	SMD TRANSISTOR 2SC3906K-T146R ROHM(RoHS)	2	Q2,Q8
192-091sc4672-e	TRANSISTOR 2SC4672(MPT3) ROHM(RoHS)	1	Q5B
192-09210376qs-e	SMD TRANSISTOR 2SA1037K-T146Q/R ROHM(RoHS)	2	Q7,Q9
192-09215146rs-e	SMD TRANSISTOR 2SA1514K-T146R ROHM(RoHS)	1	Q3
192-1582n5401-e	TRANSISTOR FSC 2N5401 AI-PNP 350V 500mA TO-92(RoHS)	1	Q6B
197-03rls4148s-e	SMD DIODE RLS4148-TE11 ROHM(RoHS)	8	D1,D2,D3,D4,D5,D5B,D6,D20
199-15000563s-e	SMD ZENER 5.6V 5% PHILIPS BZX84-C5V6(RoHS)	2	Z1,Z2
199-1500120s-e	SMD ZENER 12V 5% PHILIPS BZX84-C12 (RoHS)	4	Z3,Z4,Z5,Z6
192-232irf9640-e	FET IRF9640 IR P-CH TO220 (RoHS)	2	Q10,Q10B
192-233f640n-e	TRANSISTOR IRF640N INTERNATIONAL (RoHS)	1	Q11
<i>Miscellaneous</i>			
122-13151k0190-e	CHOKE SA-500-280 (PT1601B*151MAA) (RoHS)	1	L1
122-14300k4-e	Ferrite core LD1215*300KU ±10%(RoHS)	1	L2
175-9f40hr2-e	WIRE CONNECTOR&BASE 40PIN PITCH=2.54mm HR2*40(RoHS)	0.2	
MISCELLANEOUS/MECHANICAL			
150-r1107011-e	POWER TRANSFORMER TT0930505260	1	
152-u602015 -e	LINE CORD SVT FT-2 6FT	1	
154-k31505t0 -e	FUSE 3.15A 250V 30mm UL/CSA/PSE	1	
155-630r345b-e	FUSE HOLDER UL/CSA φ6*30mm R3-45B	1	
162-10100023 -e	WIRE UL/CSA 1617 #22 100mm BLK	1	
162-5016d001-e	WIRE 24# 160mm BLK (RoHS)	1	P108
166-5070a4bd-e	SPEAKER WIRE 700mm #18 UL1015 #205*0.5t BLK /#250*0.8t RED(RoHS)	1	
176-wjce2-e	WIRE CONNECTOR PIN CE-2	1	
180-p21f2bbd2-e	PUSH SWITCH MR-21F-2BB-D2 (RoHS)	1	
193-0s4211-e	INSULATOR (INSULATION SPACER) 42*11	1	
193-201612tr-e	INSULATOR T0-220 16mm*12mm	1	
193-201815t2-e	INSULATOR	2	

Part Number	Description	Q'ty	Reference Designator
MISCELLANEOUS/MECHANICAL			
236-AL-05001-0LAE	Aluminium bar band (RoHS)	1	
302-AL-05066-0BAE	Aluminium Panel 300*200*2.5mm ,White and Black	1	
306-ABS-00177	Plastic rear cover , 198*298*102mm	1	
311-ABS-00028-0BAE	Plastic knob, 46077-W P.V.C.	5	
323-AL-05000-0LAE	Heatsink (RoHS)	1	
325-FE-00400-0LAE	PCB bracket , 58*9*13.5T (RoHS)	1	
333-EVA-00220-0BAE	EVA Gasket ,225*15*1t UL	1	
333-EVA-00783-0BAE	EVA W 198*12*2.0T	2	
333-EVA-00807-0BAE	EVA L 274*12*2.0T (RoHS)	2	
333-EVA-00826-0BAE	EVA W 198*12*1.0T (RoHS)	2	
333-EVA-00835-0BAE	EVA L 274*12*1.0T (RoHS)	2	
333-EVA-00866	Flame prevention EVA 48*18*1.5T	2	
335-NYL-00002-0BAE	Power cord, 4K-4 NO-BB(RoHS)	2	
336-RUB-05103-0BAE	RUB gasket, 97*16*3.0T ,Black	2	
350-EM04012D024-E	4 \varnothing *12, wooden screw, crossed round head, electronic black,	4	
351-AM03008A078-E	M3*8 mechanical screw ,crossed	4	
351-AM03008A079-E	M3*8 mechanical screw ,crossed, electronic black	7	
351-AM03018A364-E	M3*8 mechanical screw ,crossed, electronic black	2	
351-HM03006A308-E	M3*6mm mechanical screw ,crossed, electronic black	1	
351-HM04010A217-E	M4 * 10 mechanical screw ,crossed, electronic black	4	
352-AM03008D040-E	\varnothing 3*8 B Screw ,crossed	2	
352-AM03008D041-E	\varnothing 3*8 B Screw ,crossed	2	
352-AM03010D065-E	\varnothing 3*10 P screw, crossed	1	
355-P07049-E	flat washer 7.2*12*0.5t	2	
361-FE-00002-0LAE	Holder of transformer 90*70*15mm (RoHS)	1	
361-FE-05016-0LAE	SECC bracket 36*12.5*8.5 (RoHS)	1	
362-FE-00013-0LAE	PCB bracket L TYPE t=1.6mm S.P.C.C 89*9*1.6T (RoHS)	1	
128-c117ja01-e	capacitor, 110uF \pm 5% DF3% 100V ψ 22*37	1	at Woofer Terminal

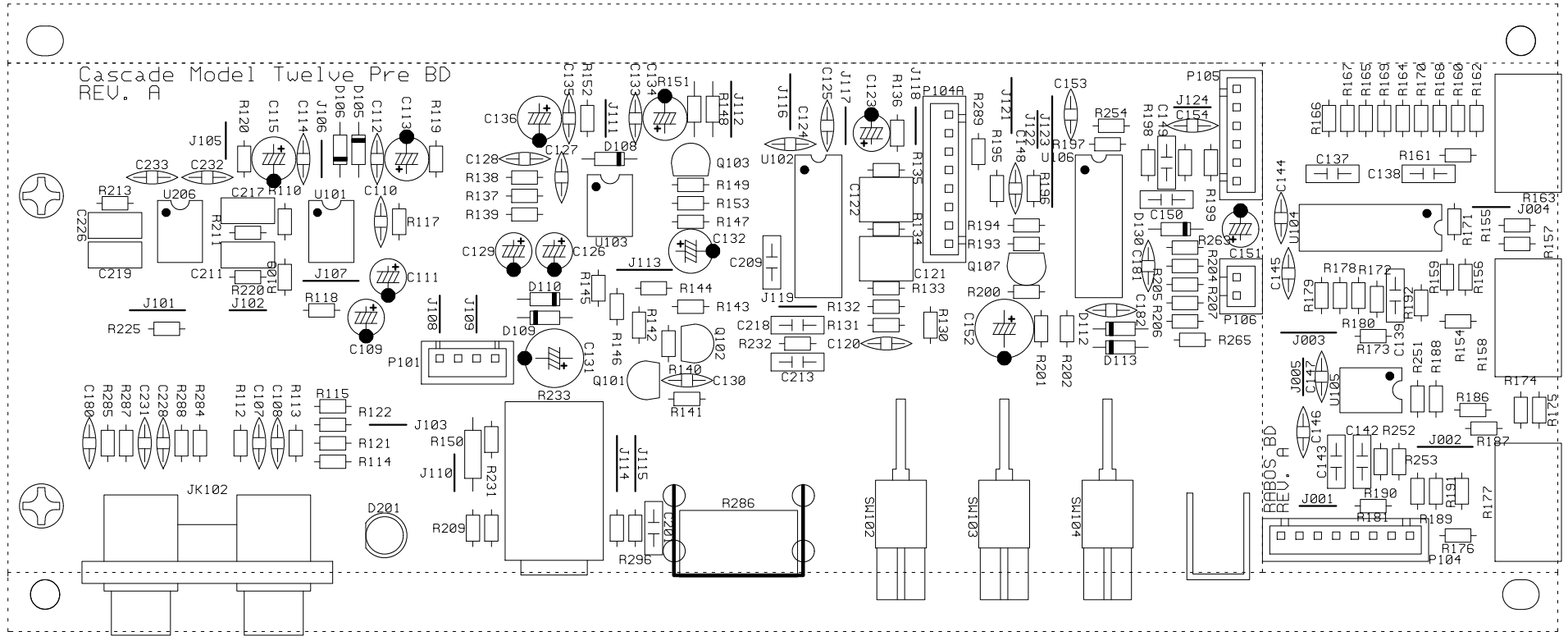

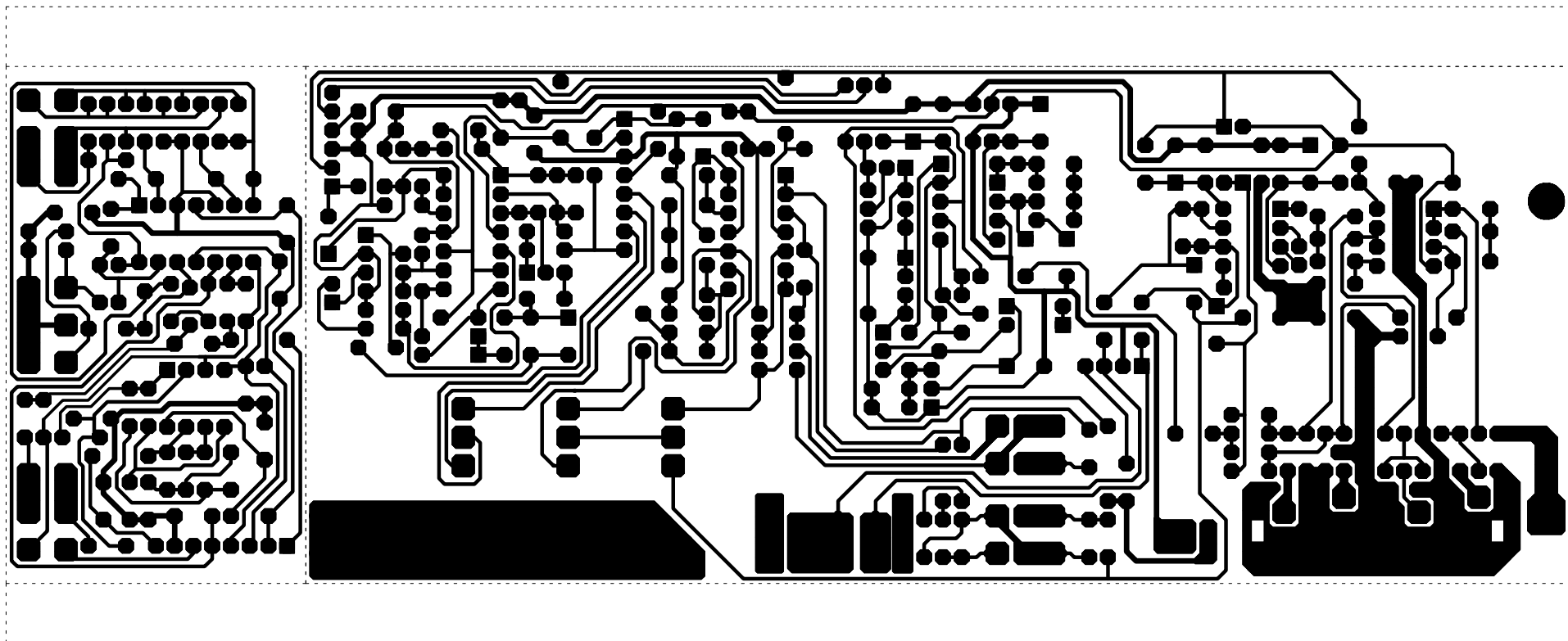

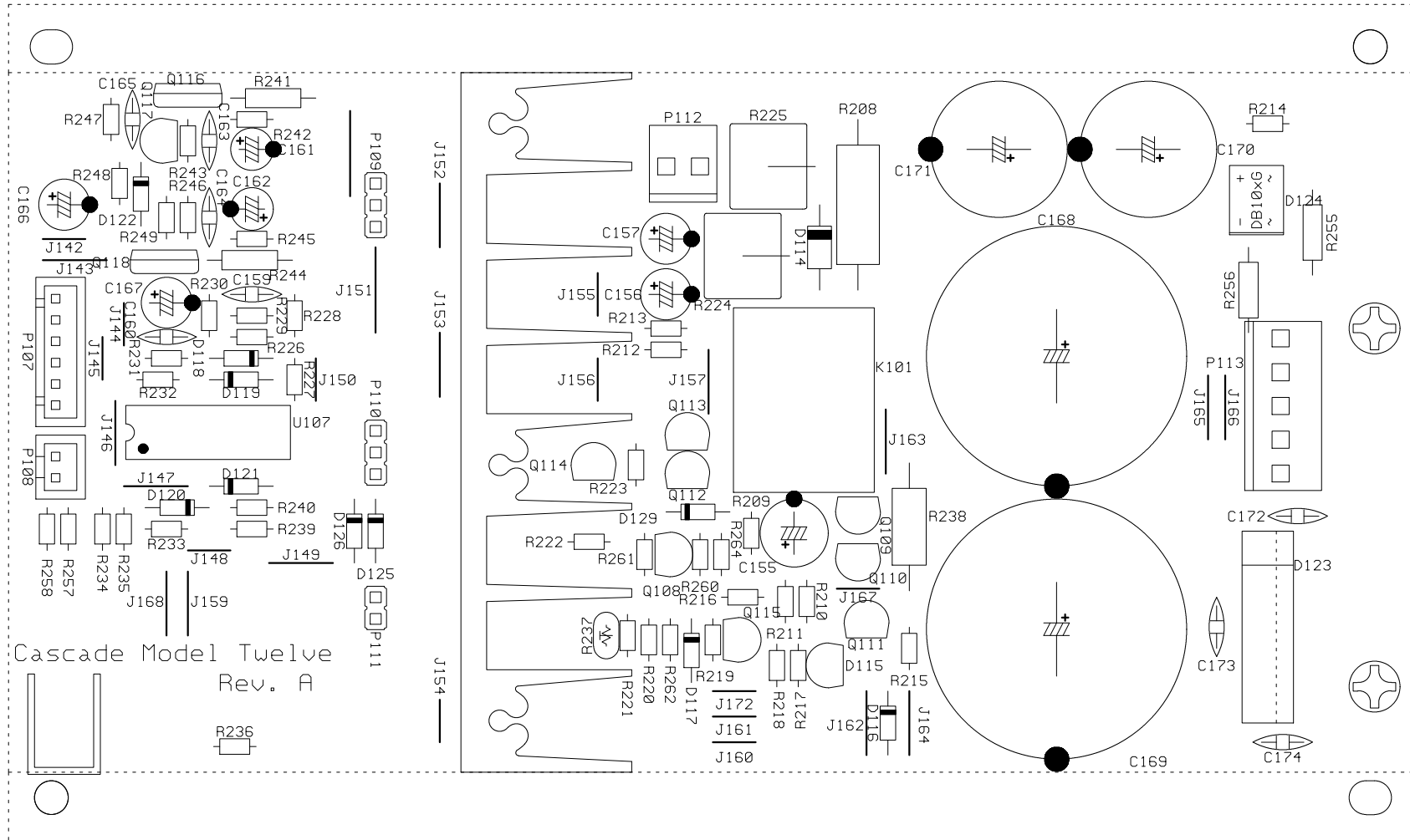

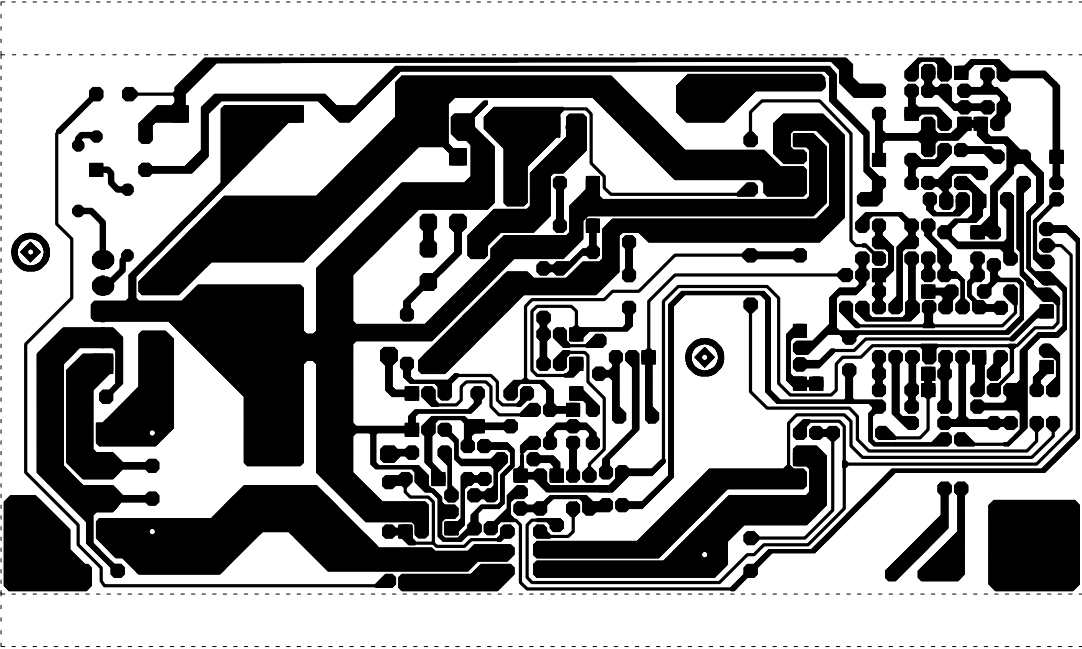

Integrated Circuit/Transistor Diagrams

2SC2412K, 2SC3906K,
2SC4672, 2SA1037K,
2SA1514

Q1-4, 5B, 7, 8, 9

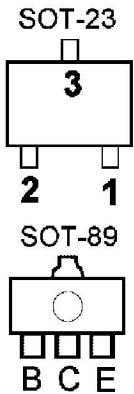

1) Emitter
2) Base
3) Collector

OPAMP, QUAD
14P DIL TLO74, LM324
U102, 104, 106, 107

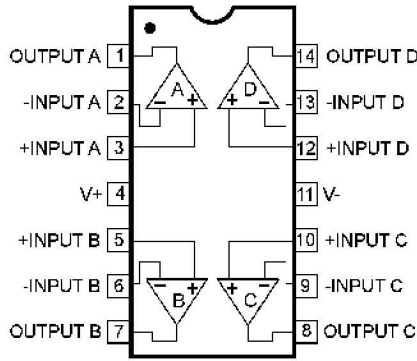

OPAMP, DUAL
TL072, 4558

U101, 103, 105, 206, IC1

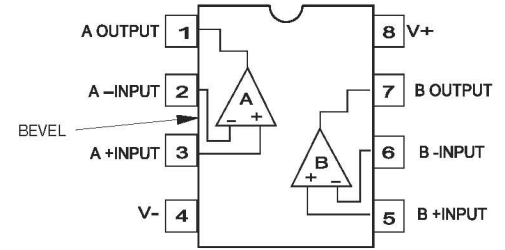

* PREFIX MAY BE "FMMT"

HSD669A, HSB649T

Q116, 118

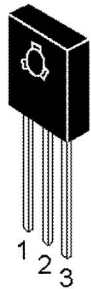

1. Emitter
2. Collector
3. Base

2N5401

Q6B, 108

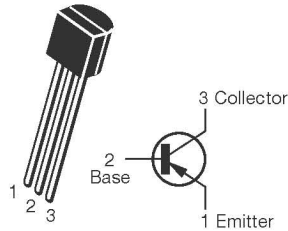

MPF102

Q107

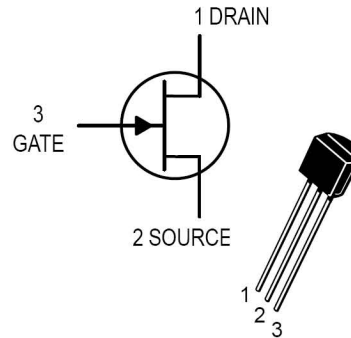

MOSFET
IRF640, 9640

Q10, 10B, 11

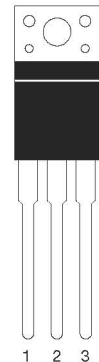

1. G
2. D
3. S

TL431 D115

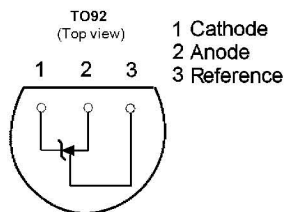

2SA1015
Q111, 113, 115

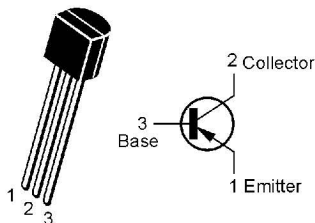

2SC1815
Q101, 102, 103, 110,
112, 114, 117

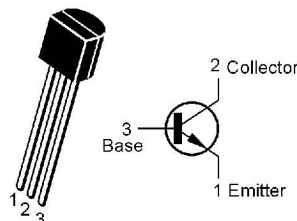

2N5551
Q109

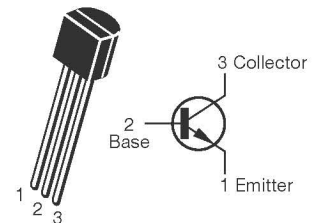

Model Twelve

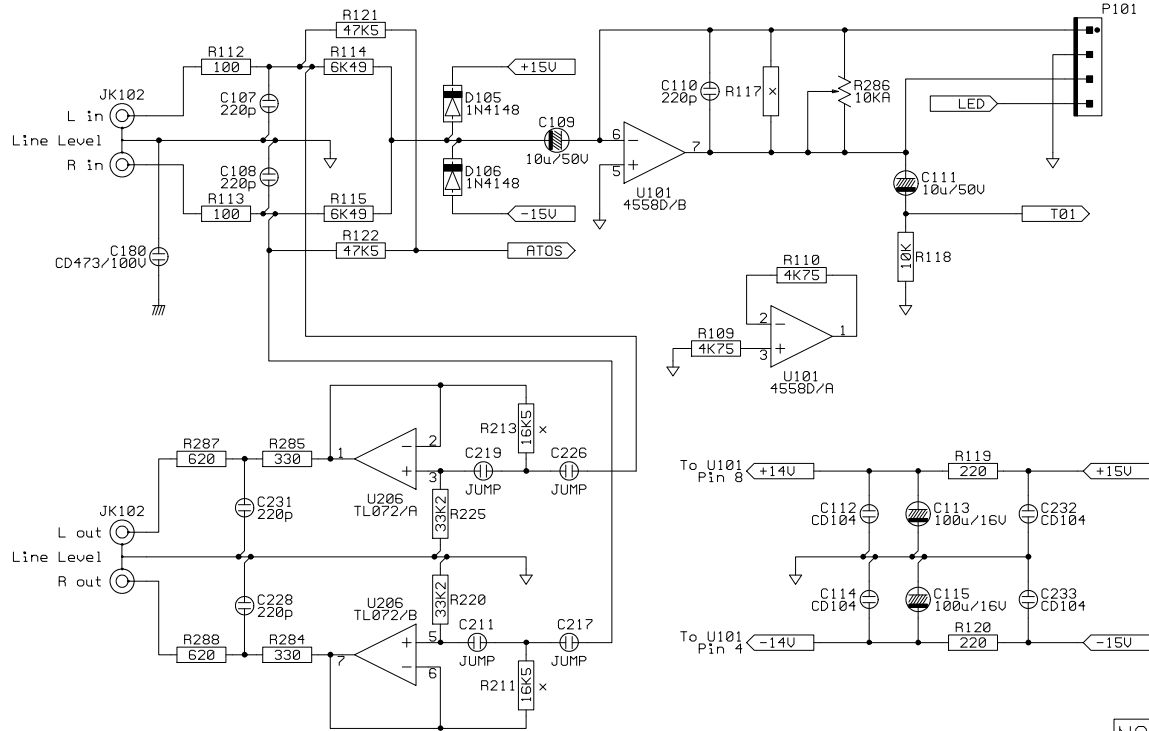

NAME : Input/PRE	1/10
MODEL : CCM12	REV: 0
CUSTOMER : Infinity	
DATE : 2006-06-10	
APPROVE BY	CHECK BY DRAWING BY

Model Twelve

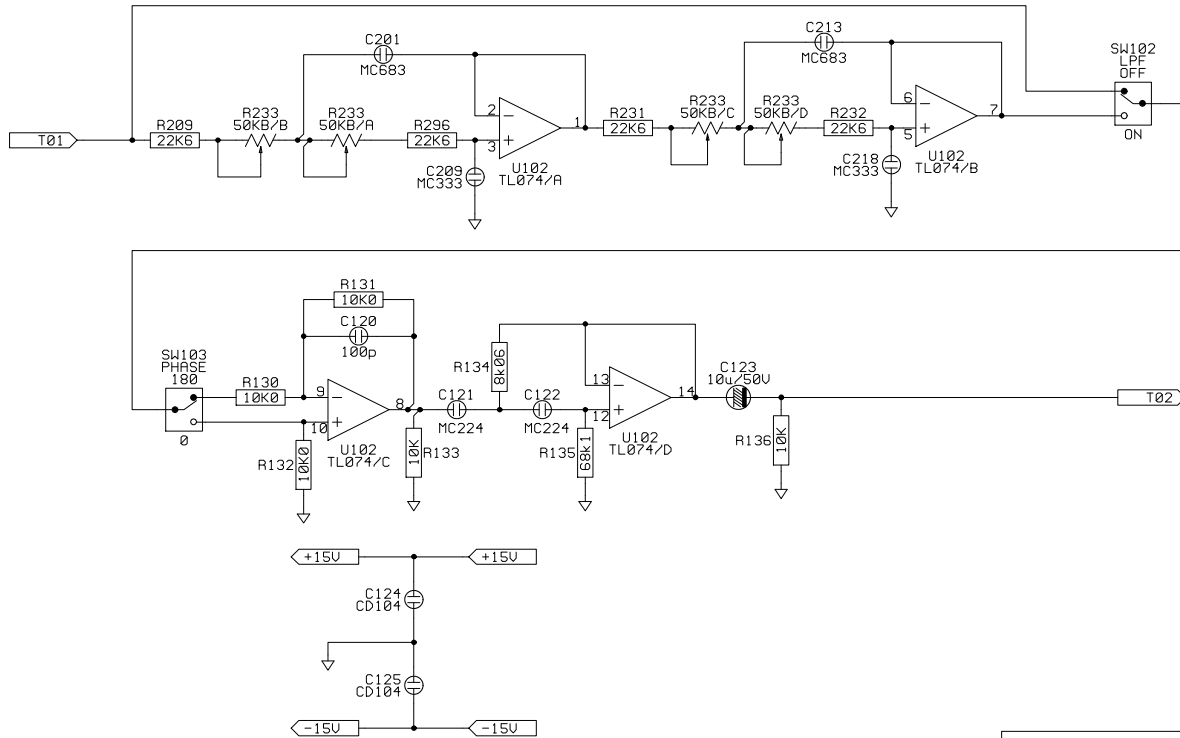

NAME : Filter/PRE	2/10
MODEL : CCM12	REV: 0
CUSTOMER : Infinity	
DATE : 2006-06-10	
APPROVE BY	CHECK BY DRAWING BY

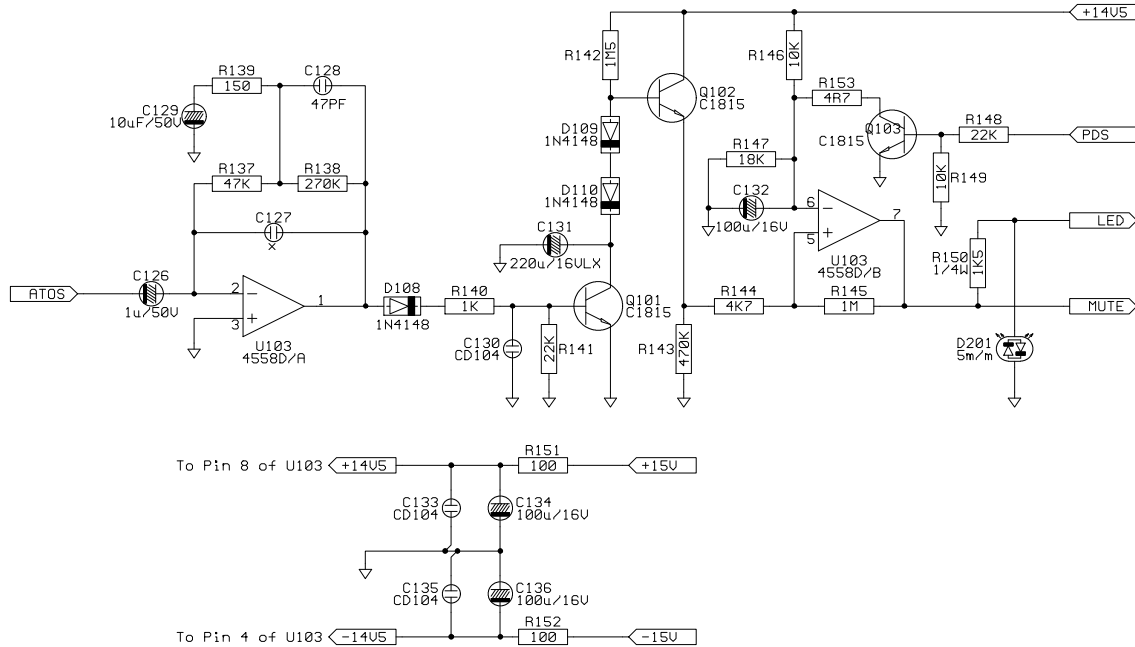

NAME :Auto on/PRE	3/10
MODEL :CCM12	REV: 0
CUSTOMER :Infinity	
DATE : 2006-06-10	
APPROVE BY	CHECK BY DRAWING BY

Model Twelve

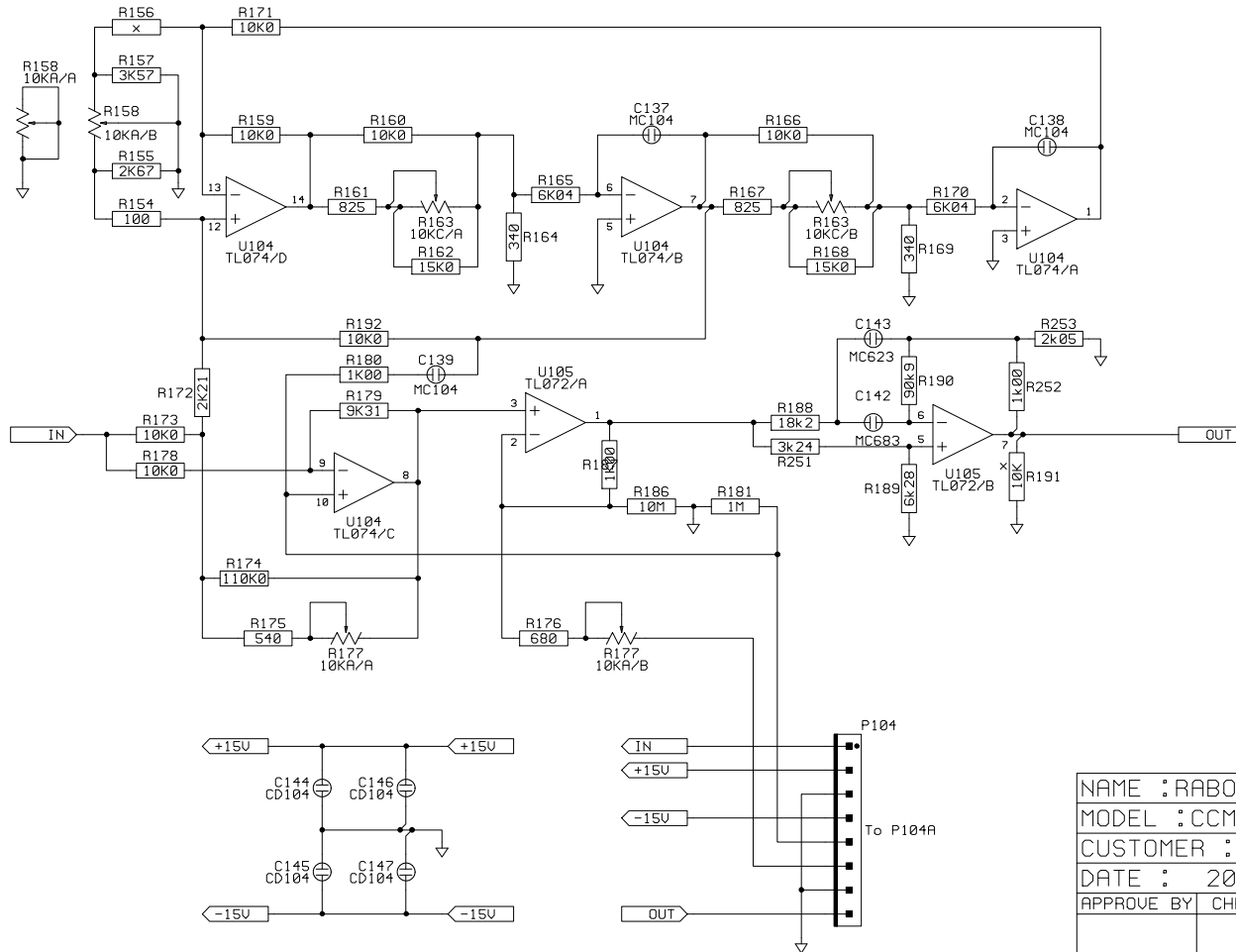

NAME :RABOS/RABOS	4/10
MODEL :CCM12	REV:0
CUSTOMER : Infinity	
DATE : 2006-06-10	
APPROVE BY	CHECK BY DRAWING BY

Model Twelve

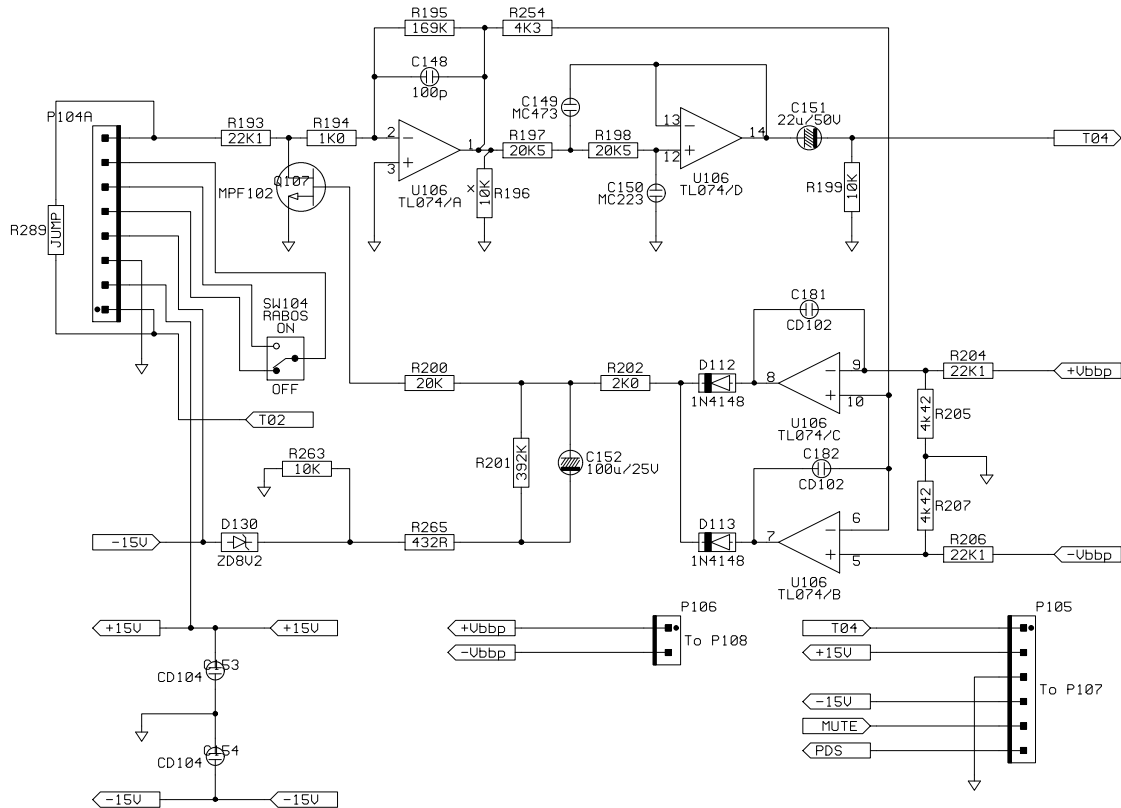

NAME : Limiter/PRE	5/10
MODEL : CCM12	REV: 0
CUSTOMER : Infinity	
DATE : 2006-06-10	
APPROVE BY	CHECK BY DRAWING BY

Model Twelve

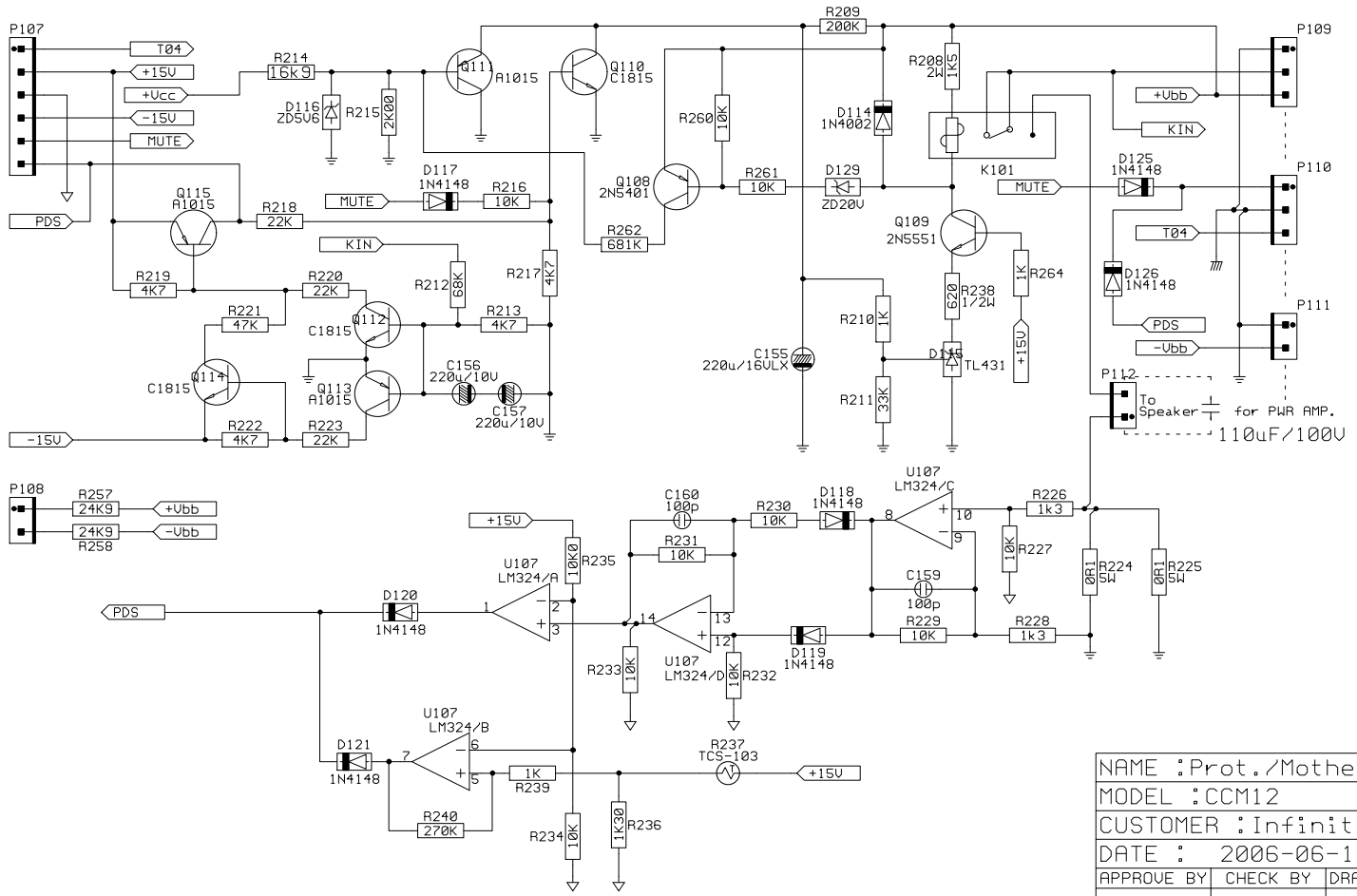

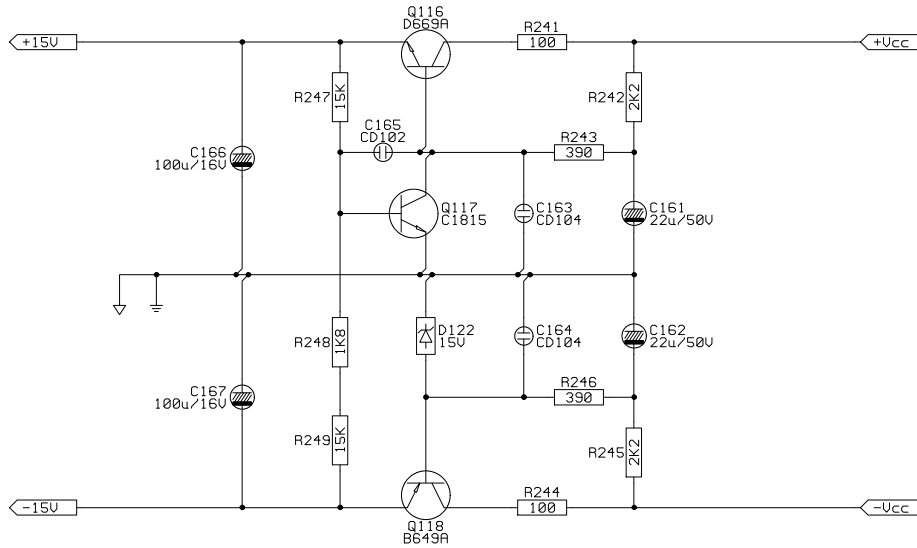

NAME : PN15U/Mother	7/10
MODEL : CCM12	REV:0
CUSTOMER : Infinity	
DATE : 2006-06-10	
APPROVE BY	CHECK BY DRAWING BY

Model Twelve

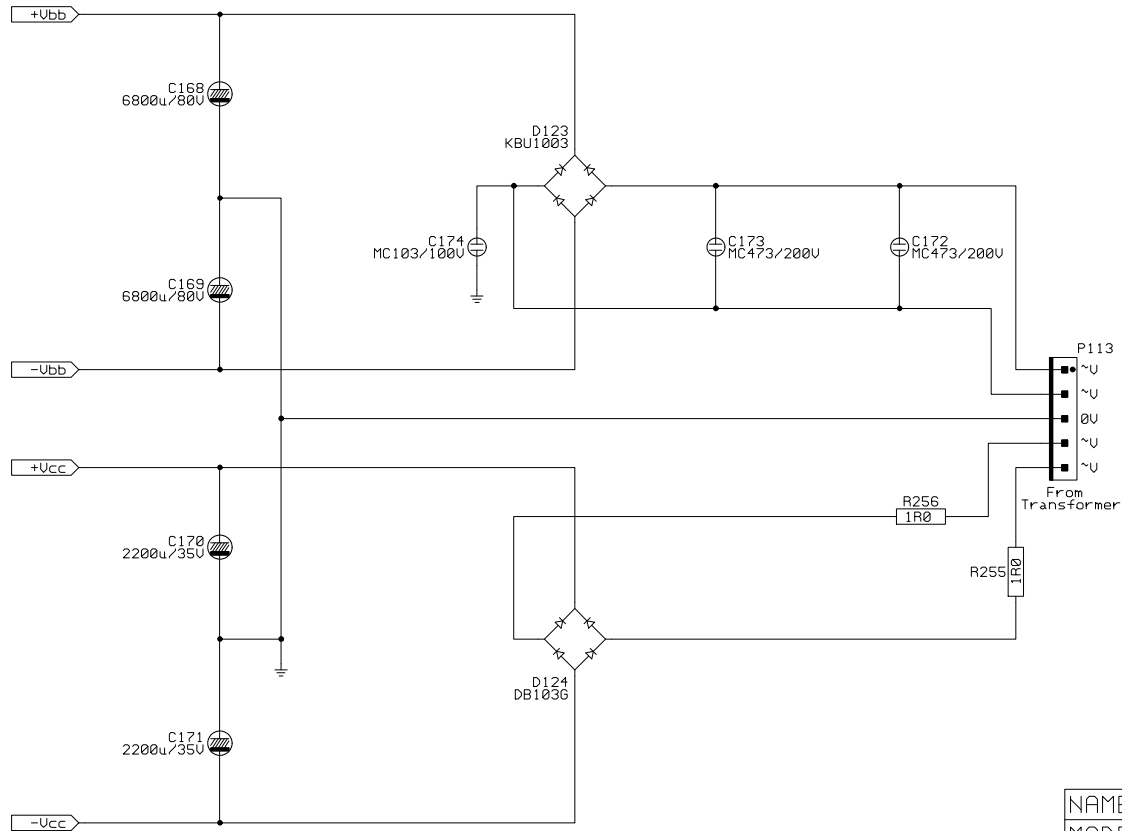

NAME : DCPWR/Mother	8/10
MODEL : CCM12	REV: 0
CUSTOMER : Infinity	
DATE : 2006-06-10	
APPROVE BY	CHECK BY DRAWING BY

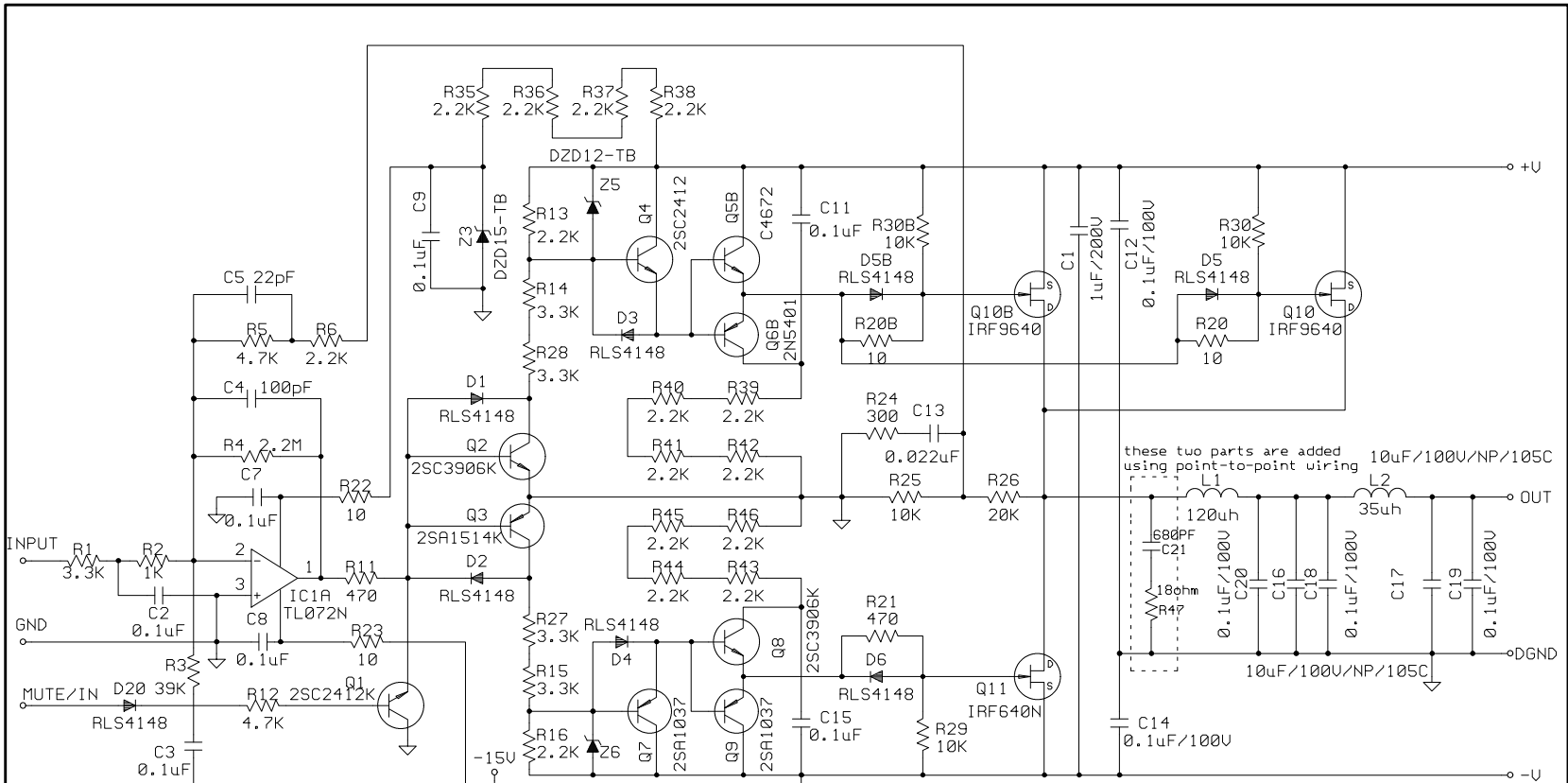

these two parts are added using point-to-point wiring

10uF/100V/NP/105C

120uH

35uH

10uF/100V/NP/105C

10uF/100V/NP/105C

10uF/100V/NP/105C

NAME : PWA/CDPWA	9/10
MODEL : CCM12	REV: 0
CUSTOMER : Infinity	
DATE : 2006-06-10	
APPROVE BY	CHECK BY DRAWING BY

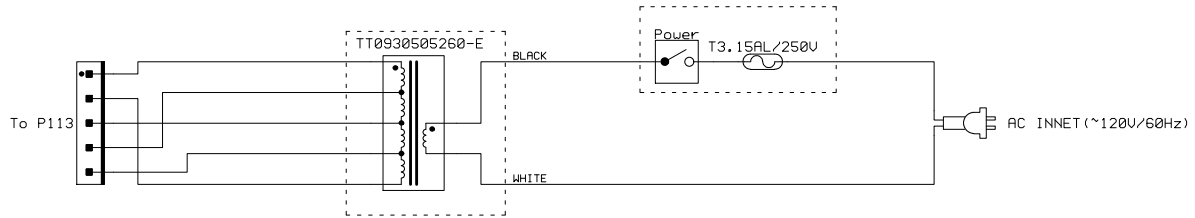

APPROVE BY	CHECK BY	DRAWING BY	NAME : AC INLET	9/10
			MODEL : CCM12	REV: 0
			CUSTOMER : Infinity	
			DATE : 2006-06-10	