



BU80

BU80E

HTS-10

POWERED SUBWOOFER

SERVICE MANUAL



Infinity Systems, Inc.
250 Crossways Park Dr.
Woodbury, New York 11797

Rev H 11/2001

SAFETY INFORMATION/VERSION DIFFERENCES

Warning

Any person performing service of this unit will be exposed to hazardous voltages and the risk of electric shock. It is assumed that any person who removes the amplifier from this cabinet has been properly trained in protecting against avoidable injury and shock. Therefore, any service procedures are to be performed by qualified service personal ONLY!

Caution

This unit does not have a power switch. Hazardous voltages are present within the unit whenever it is plugged in.

Before the amplifier is plugged in, be sure its rated voltage corresponds to the voltage of the AC power source to be used. Incorrect voltage could cause damage to the amplifier when the AC power cord is plugged in. Do not exceed rated voltage by more than 10%: operation below 90% of rated voltage will cause poor performance or may shut the unit off.

List of Safety Components Requiring Exact Replacements

F1 **	Fuse SLO BLO 0.50A or 1.0A 250V 5 x 20mm. UL approved See Bulletin (INF2000-02) page 16.
PWRCORD	SPT-2 or better with polarized plug, UL approved wired with the hot side to fused side. Use with factory replacement panel strain relief only.
T1 **	Transformer. Use only factory Replacement.
DBR or D001	Bridge diode. Use only factory replacement.
C1, 2	3300uF, 50V electrolytic filter caps. Be sure replacement part is at least the same working voltage and capacitance rating. Also the lead spacing is important. Incorrect spacing may cause premature failure due to internal cabinet pressure and vibration.
C6 *	10uF 50V electrolytic radial (BU80 and HTS-10 version "A", "B" only)
S53AMI or CON101	Power output module. Use only factory replacement
Faceplate	Use only factory replacement
Air leak cover	Use only factory replacement
CMC1	Use only factory replacement
L1	Use only factory replacement
Fuse PCB	Use only factory replacement
Main PCB	Use only factory replacement
R29	470 ohm 1/4W METAL OXIDE, non flammable

Leakage/Resistance Check

Before returning the unit to the customer, perform a leakage or resistance test as follows:

Leakage Current. Note there is no power switch on this unit. When the power plug is plugged in, the unit is live. Connect the unit to its rated power source. Using an ammeter, measure the current between the neutral side of the AC supply and chassis ground of the unit under test. If leakage current exceeds 0.5mA, the unit is defective. Reverse the polarity of the AC supply and repeat.

Resistance. Measure the resistance from either side of the line cord to chassis ground. If it is less than 500k ohms, the unit is defective.

WARNING! DO NOT return the unit to the customer if it fails one of these tests until the problem is located and corrected.

* See **Service Bulletin (INF2000-01)** page 15.

** See **Service Bulletin (INF2000-02)** page 16.

Rev A version of the BU-80/HTS-10 subwoofer uses the following SAFETY PARTS:

#80103 - **T1** Power Transformer #4300
#80104 - **F1** Line fuse 0.5A 250V T type slo-blo

Rev B version of the BU-80/HTS-10 subwoofer uses the following SAFETY PARTS:

#80127 - **T1** Power Transformer #4300F
#80111 - **F1** Line fuse 1.0A 250V T type slo-blo

Either **Rev A** or **Rev B** can be identified by:

The correct fuse rating will be printed on the amplifier label, also:

BU-80: Rev A version

serial #AM0011-29474 and below;

Rev B version serial #AM0011-29475 and above.

HTS-10: Rev A version serial #AM0011-07400 and below;

Rev B version serial #AM0011-07401 and above.

HTS-10 subwoofer only

There is a third version, "C", with minor internal differences.

Data for this version is included, and differences are noted in the manual.

Units can be identified for service as follows:

Amplifier faceplate says "Made in Canada" on the "B" version.

Amplifier faceplate says "Made in China" on the "C" version.

BU80E = HTS-10 version, "C"

TABLE OF CONTENTS

SAFETY INFORMATION/VERSION DIFFERENCES...2	BU80/BU80E/HTS-10 AMPLIFIER ASSEMBLY EXPLODED VIEW18
GENERAL SPECIFICATIONS3	BU80/BU80E/HTS-10 PACKING & CABINET PARTS..20
DETAILED SPECIFICATIONS.....4	BU-80/HTS-10 rev. A, B PCB (version 5)21
CONTROLS AND THEIR FUNCTION.....5	BU-80/HTS-10 rev A, B PCB (version 5.1)22
BU80/BU80E/HTS-10 CONNECTIONS6	BU-80/HTS-10 rev A, B ELECTRICAL PARTS LIST ...23
OPERATION10	BU80/BU80E/HTS-10 INTEGRATED CIRCUIT/ TRANSISTORS DIAGRAM24
BU80/BU80E/HTS-10 TEST SET UP PROCEDURE...11	BU-80/HTS-10 rev A, B SCHEMATIC 1 of 225
BU-80/HTS-10 POWER AMP TEST PROCEDURE FLOW CHART13	BU-80/HTS-10 rev A, B SCHEMATIC 2 of 226
SERVICE BULLETIN INF9902 - APRIL 199914	BU80E/HTS-10 REV C ELECTRICAL PARTS LIST ...27
SERVICE BULLETIN INF2000-01rev2 - FEBRUARY 200115	BU80E/HTS-10 REV C CIRCUIT BOARDS29
SERVICE BULLETIN INF2000-02 - MARCH16	BU80E/HTS-10 REV C SCHEMATIC32
TECH TIPS17	BU80E/HTS-10 REV C POWER AMP MODULE SCHEMATIC33

GENERAL SPECIFICATIONS

- Frequency Response (± 3 db).....45Hz - 150Hz
 - Output (RMS)75W
 - Driver8" Woofer
 - Crossover Frequency50Hz ~ 150Hz (continuously variable)
 - Dimensions (H x W x D)11½" (29.2cm) x 11½" (29.2cm) x 11½" (29.2cm)
Add 1¾" (4.5cm) for feet.
 - Weight26 lbs/11.8 kg,
- Refinements may be made on occasion to existing products without notice, but will always meet or exceed original specifications unless otherwise stated.

IMPORTANT SERVICE NOTES: When testing the BU Series amplifier, a load must always be connected to the output terminals, whether the woofer, or a 4 to 8 ohm resistive load. All AC powered test instruments (meters, oscilloscopes, etc.) must have a floating ground, i.e. be connected to an isolation transformer.

DETAILED SPECIFICATIONS

LINE VOLTAGE	Yes/No	Hi/Lo Line	Nom.	Unit	Notes
US 120vac/60Hz	Yes	108-132	120	Vrms	Normal Operation
EU 230vac/50-60Hz	Yes	207-264	230	Vrms	Normal operation, MOMS required
Asia 100vac/50Hz	No	90-110	100	Vrms	Normal Operation
Parameter	Specification	Unit	QA Test Limits	Conditions	Notes
Type (Class AB, D, other)	D	n/a	n/a		
Load Impedance (speaker)	4	Ohms	n/a	Nominal	
Rated Output Power	50	Watts	50	1 input driven	
THD @ Rated Power	0.3	%	1	22k filter	50w (Power Bandwidth 30-100Hz)
THD @ 1 Watt	0.8	%	1	22k filter	
DC Offset	10	mV-DC	20	@ Speaker Outputs	
Damping factor	100	DF			
Input Sensitivity					
Input Frequency	45	Hz	40	Nominal Freq.	1 input driven
Line Input	86	mVrms	±2dB	To Rated Power/ Vol @ Max	1 input driven: AP source Z = 600 ohms
Speaker/Hi Level Input	2.3	Vrms	±2dB	To Rated Power/ Vol @ Max	1 input driven: AP source Z = 25 ohms
Signal to Noise					
SNR-A-Weighted	95	dBA	85	Relative to rated output	A-Weighting filter
SNR-unweighted	75	dBr	65	Relative to rated output	22k filter
SNR rel. 1W-unweighted	55	dBr	50	relative to 1W Output	22k filter
Residual Noise Floor	2.5	mVrms	4	Volume @max, using RMS reading on A/P	22k filter required due to 100kHz switching noise present at speaker output
Input Impedance					
Line Input	10k	ohms		Nominal	
Speaker/Hi Level Input	200	ohms		Nominal	
Filters					0dBr = 1w @ 50Hz
Low Pass (fixed or variable)	Variable				
Low Pass filter (point or range)	50-150	Hz	±2dB	-3dB Point	
Slope	18	dB/Octave	n/a		
Q	n/a	n/a	n/a		
Subsonic filter (HPF)	35	Hz	±2dB	-3dB Point	
Slope	18	dB/Octave	n/a		
Limiter (yes/no)	yes				
Max. Output Power/THD=10%	62w @ 10%	P-max/THD	functional	Maximum Output Power	Maximum THD as a result of limiting.
Features					
Phase Switch (yes/no)	yes	--	functional		
Volume pot Taper (lin/log)	linear	--	functional		
Input Configuration					
Line In (L,C,R,AC3,Mono)	L,R	--	functional	Enabled w/Line/Spkr Input Select Switch	
Line Outputs (L,C,R)	L,R	--	functional		Buffered Output / Pre-Volume control
Line-Out Adj. X-over	no	Hz	n/a	n/a	n/a
Spkr/Hi Level In (L,C,R,mono)	L,R	--	functional	Enabled w/Line/Spkr Input Select Switch	
Spkr Out: Hi Pass Filter	100	Hz	functional	8 ohm Satellite: 6dB/oct passive xover	Driven from zero ohms source impedance
Signal-Present LED	Yes	--	--	--	Bi-Color LED (green=signal/ red=no signal)
Signal-Present Input Freq.	100	Hz	functional	Nominal	200uF Series Cap on PCB
Signal-Present Level	7	mV	functional	100Hz into Line Input w/ 1 ch. driven	
Power on Delay time	<2	sec.		AC Power Applied	
Transients/Pops					
Turn-on Transient	500	mV-peak	2v-pp	@ Speaker Outputs	AC Line cycled from OFF to ON
Turn-off Transient	500	mV-peak	2v-pp	@ Speaker Outputs	AC Line cycled from ON to OFF
Efficiency					
Stand-by Input Power	12	Watts	n/a	@ nom. line voltage	
Power Cons. @rated power	80	Watts	n/a	@ nom. line voltage	
Efficiency	63%	%	n/a	Relative to rated output	
Protection					
Short Circuit Protection	yes		functional	Direct short at output	
Line Fuse Rating	0.5 or 1.0A*	Amps		Type-T or Slo Blo	* See Line fuse note on Page 2

CONTROLS AND THEIR FUNCTION

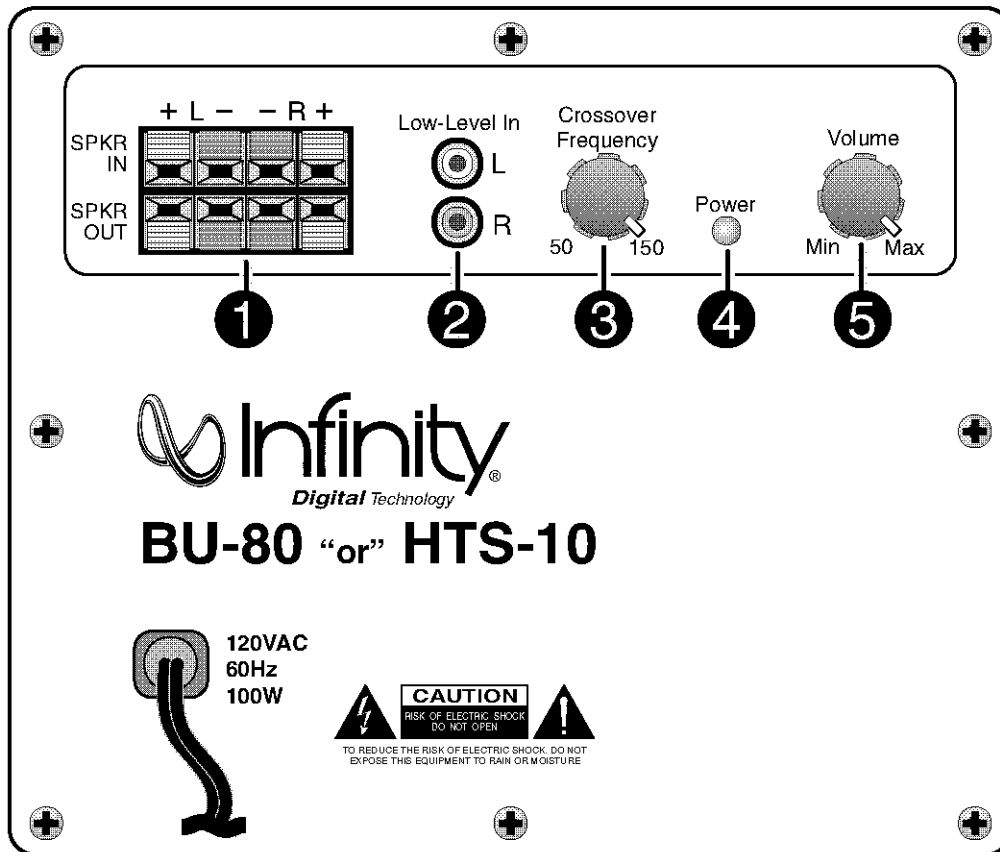

00502-1_P

1. High-Level input and Output terminals
2. Low-Level Input Jacks: connect to preamplifier outputs
3. Crossover Frequency: controls upper-corner roll-off points.
4. Power-On indicator
5. Volume Control: controls volume of subwoofer.

BU-80/BU80E/HTS-10 CONNECTIONS

When connecting your subwoofer make sure you turn all the power off.

There are several ways to connect your subwoofer. Read this section carefully to determine which method is best suited for your installation.

The subwoofer may be fed directly with a low-level signal taken from a preamplifier's output by using the second set of output jacks on the rear of the preamplifier (See Figure 1). If a preamplifier has only one set of outputs, you may use two (2) "Y" connectors (See Figure 2) to connect the subwoofer. Use standard shielded leads terminated at each end with male RCA connectors. Connect one end of each stereo pair of leads to the preamplifier's left and right outputs and connect the other end to the corresponding left and right LOW-LEVEL INPUTS (1) on the subwoofer.

If you are using a tube preamplifier and the connecting leads will be longer than 10 feet (3 meters), we recommend not using the above connection method. A tube preamplifier may not be able to handle the capacitance introduced by leads more than 10 feet in length. Instead, try using the high-level connection methods listed on pages 5-7.

Figure 1. - A low-level signal can be used from a preamp's output by connecting second set of output jacks to the rear of your amplifier.

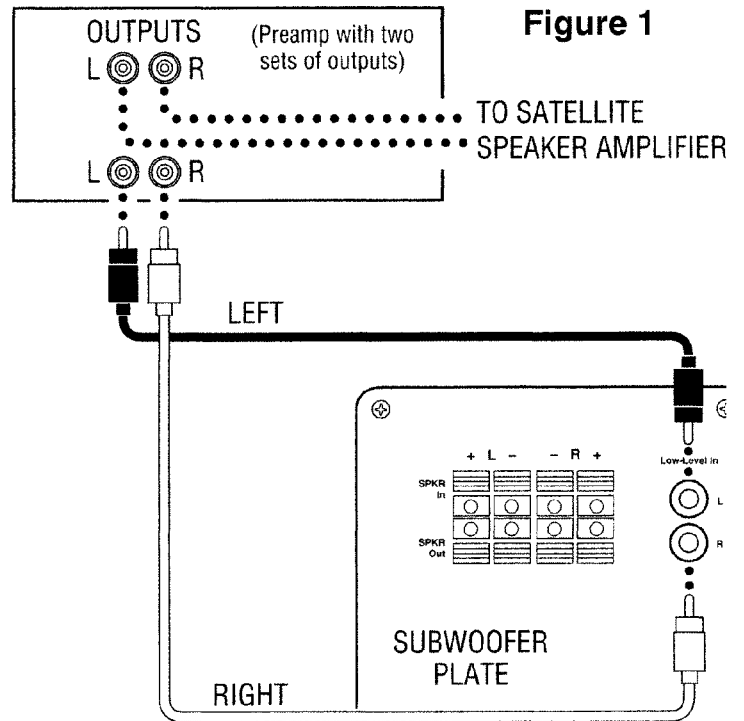
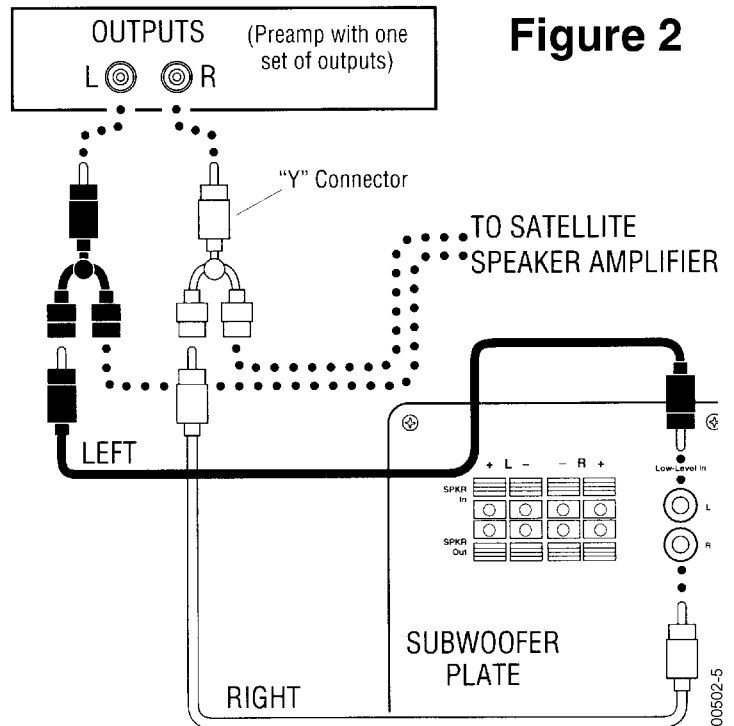

Figure 2. - You can use this method (2"Y" connectors) if your preamp has only one set of outputs.



BU-80/BU80E/HTS-10 CONNECTIONS (Cont.)

When using a single subwoofer, you MUST use a pair of stereo low-level leads from your preamplifier's outputs. When using two subwoofers, one for the left and another for the right channels, connect the left preamplifier output to BOTH the left and right LOW-LEVEL INPUTS of the subwoofer used for the left channel by using a Female-to-Male "Y" connector at the subwoofer's output. Connect the right-channel preamplifier output to both jacks of the right-channel subwoofer in the same manner (See Figure 3). If the preamplifier has a mono subwoofer output, you'll also need a Male-to-Female "Y" connector to split the mono signal to the subwoofer pair (See Figure 3).

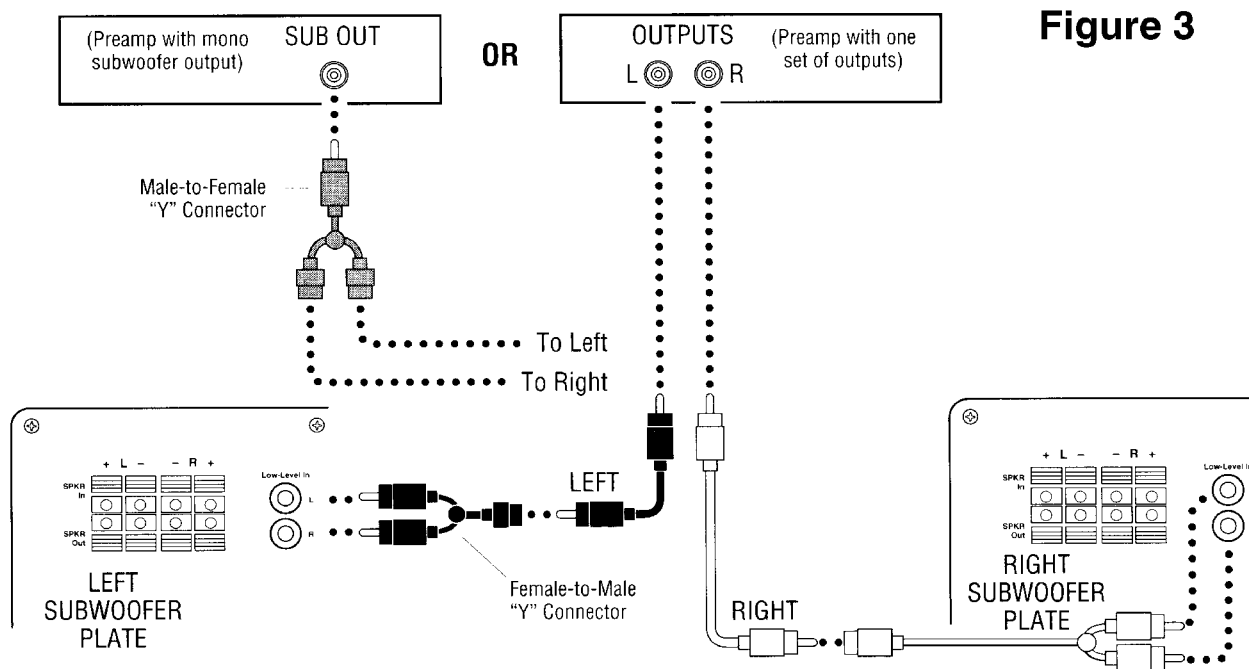

Figure 3

Figure 3. - Use this method when using single subwoofer or two subwoofers.

The subwoofer may be connected to your system using the HIGH-LEVEL INPUTS (4) on the plate located on the rear panel of the subwoofer. Use speaker wire, maintaining proper polarity (+ to + and - to -). Attach the speaker wire to the left and right HIGH-LEVEL INPUTS on the subwoofer and the other ends to the proper left and right OUTPUTS on your amplifier or receiver (See Figure 4).

If you plan to use two subwoofers (one for the left and the other for the right channel), connect wires from the left and right OUTPUT on your power amplifier or receiver and attach the other ends to the corresponding HIGH-LEVEL INPUTS on each subwoofer. Observe polarity (See Figure 5).

Figure 4. - Use this method when using a single subwoofer.

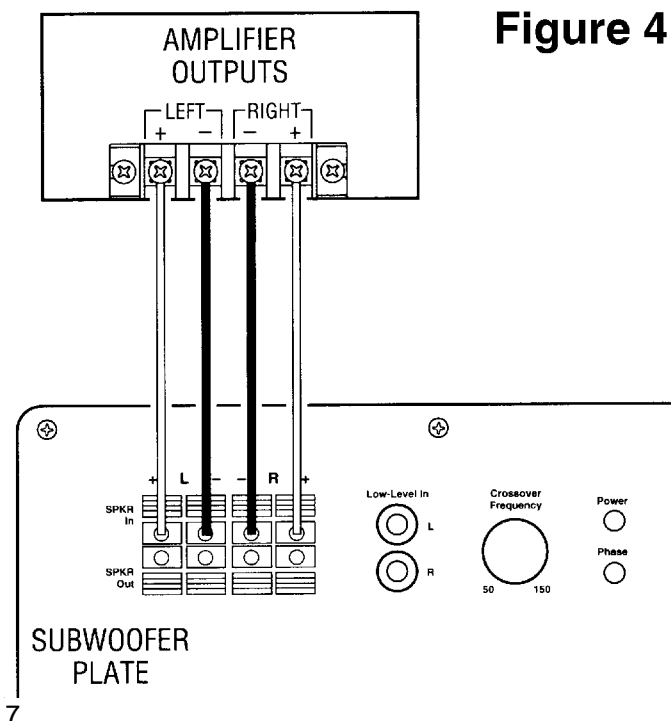

Figure 4

BU-80/BU80E/HTS-10 CONNECTIONS (Cont.)

Figure 5. - Use this method when using two subwoofers.

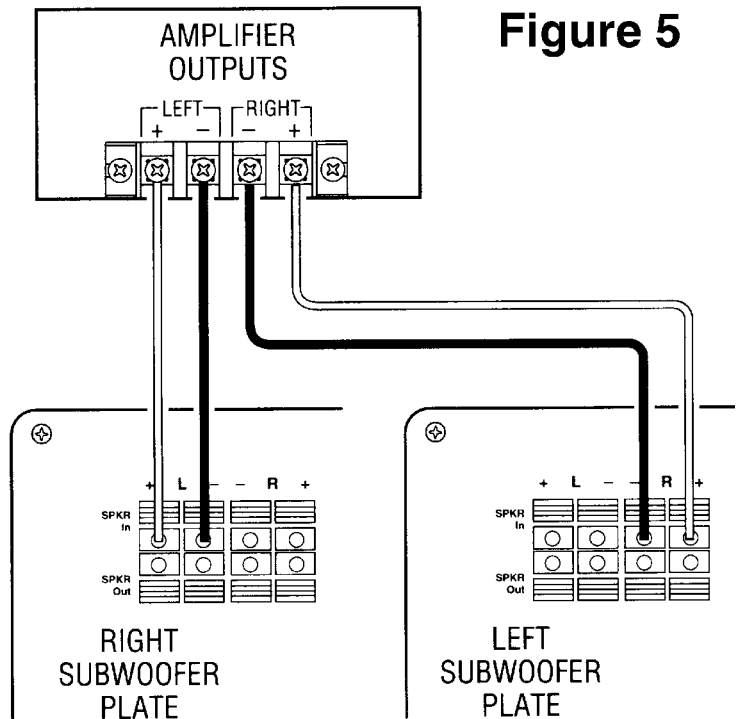

Figure 5

Figure 6. - Use this method when connecting one subwoofer to satellites.

Depending on whether you are using one or two subwoofers, connecting your satellites can be accomplished in one of two ways. If you are using a single subwoofer with a pair of satellites, connect them as shown in Figure 6.

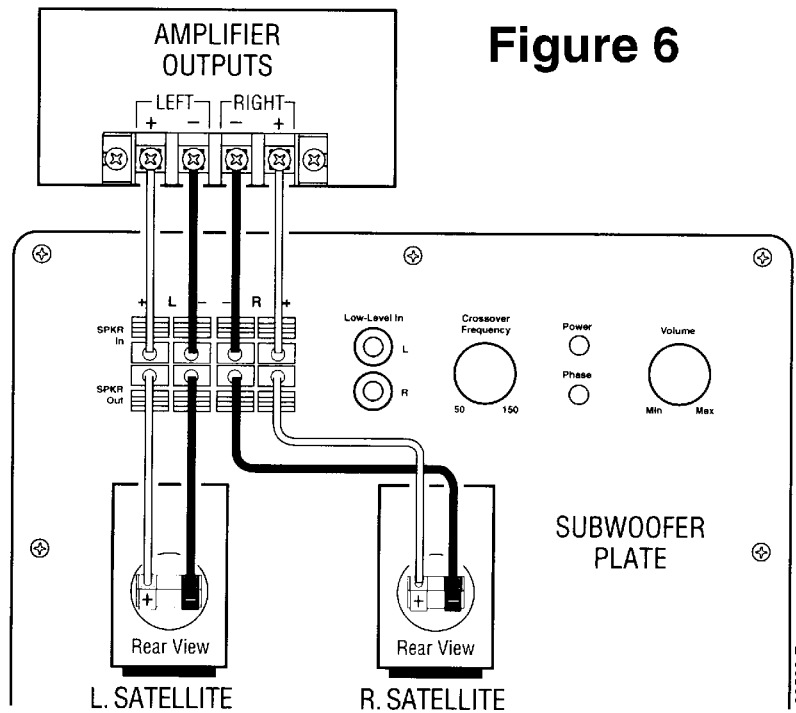

Figure 6

BU-80/BU80E/HTS-10 CONNECTIONS (Cont.)

Figure 7. - Use this method when connecting two subwoofers to satellites.

If you are using two subwoofers as a stereo pair with a pair of satellites, connect them as shown in Figure 7.

The subwoofer has a variable frequency control that can be used to block unwanted frequencies (between 50 - 150Hz) from being reproduced by the subwoofer. When you set this control depends on the low-frequency capabilities of your satellite speakers. Adjust this knob to the lowest frequency that you satellite speakers were designed to reproduce (refer to Operation, step 7).

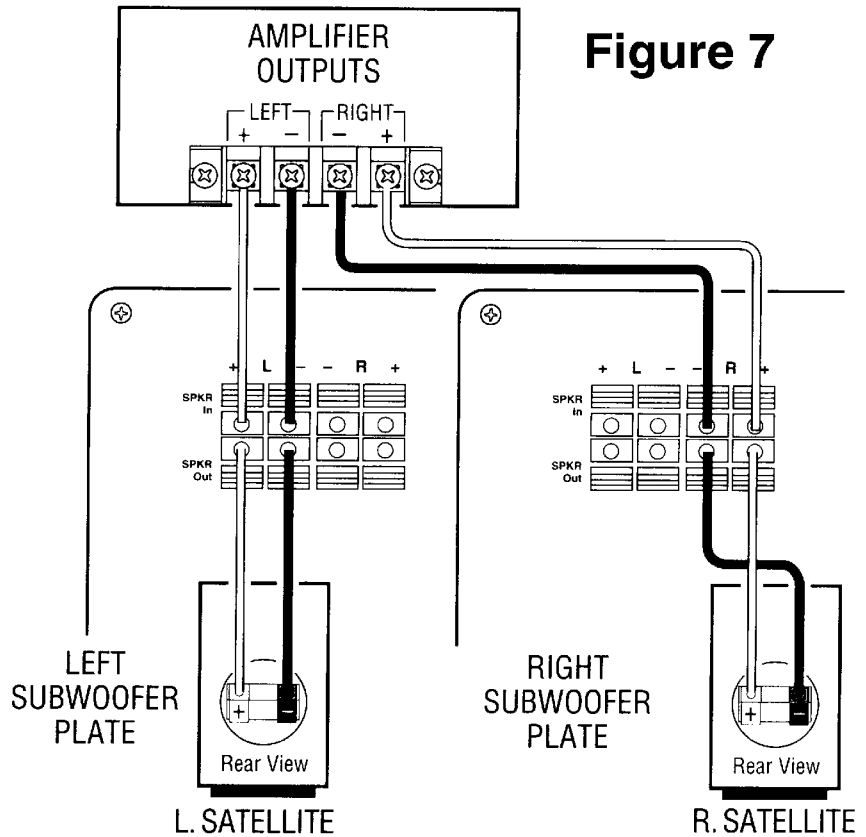

00502-8

OPERATION

Setting the Controls

1. Initially set the subwoofer's Volume control to the minimum position.
2. Initially set the subwoofer's Crossover Frequency control to 12 o'clock.

Turn the Power On

4. Turn on the entire audio system and play any music source.
5. Turn the Volume control to its mid position. If no sound emanates from the subwoofer, check the AC line cord and input cables. Are the connectors on the cables making proper contact? Is the AC plug connected to a "live" receptacle?

Adjusting the Volume

6. Set the overall volume control of the preamplifier or stereo to a comfortable level. Adjust the subwoofer's Volume control until you obtain a pleasing blend of bass. Bass response should not overpower the room but rather be adjusted so there is a harmonious blend across the entire musical range. Many users have a tendency to set the subwoofer volume too loud following the belief that a subwoofer is there to produce lots of bass. This is not entirely true. A subwoofer is there to enhance bass, extending the response of the entire system so the bass can be felt as well as heard. However, overall balance must be maintained; otherwise, the music will not sound natural. An experienced listener will set the volume of the subwoofer so its impact on bass response is always there but is never obtrusive.

The Crossover Frequency Controls

7. The Crossover Frequency control sets the high-frequency roll-off, adjustable from 50 to 150Hz. Where you set this control depends on the low-frequency capabilities of your satellite speakers, system placement, and other factors affecting the mid-bass region. Turn the control UP (clockwise) until you feel there is too much mid-bass information (around 100Hz), then back the control down a bit until that area sounds more natural. To hear more low bass, turn the Crossover Frequency control DOWN a bit and the Volume control UP by about the same amount. This will increase low bass while leaving the mid-bass sounding the same as it did before the adjustment. To reduce low bass without changing midbass, turn the Crossover Frequency control UP and the Volume control DOWN.

Room Placement

8. The room placement of the subwoofer is the most critical aspect of its installation. It will be necessary for you to try various locations in your listening room before you choose the final location. Some possible starting points include: behind the right channel satellite speaker, along the back wall between the satellites, along a side wall (but not too close to a corner), or behind a couch or a chair.

In general, the closer the subwoofer is to wall and corners, the greater the effect of low-frequency enhancement. Experiment with the Crossover Frequency and Volume controls in different locations until you are pleased with the result you obtain from your particular application.

A Word of Advice

The Low-Frequency Roll-off and Volume controls may be set anywhere within their rotation. However, it will be a most unusual circumstance if you have to set the Volume control completely clockwise. This may indicate an unbalanced condition in your system (too much bass) or an especially large room, or room placement may not be correct. Try several other locations before concluding that the Volume control must be set at maximum.

A Word About Tone Controls

The tone controls on your electronic components (preamplifier, receiver, etc.) should be used with the utmost discretion. Excessive boost can create severe power demands on your power amplifier. Maximum bass boost can create a demand for literally hundreds of watts in the bass region, whereas in the "flat" position, or with the tone controls switched out of the system, your average listening level may be impressively and realistically loud at less than 10 watts. The remaining power capacity required is on reserve for power peaks on sharp transients and powerful crescendos.

BU-80/BU80E/HTS-10 TEST SET UP AND PROCEDURE

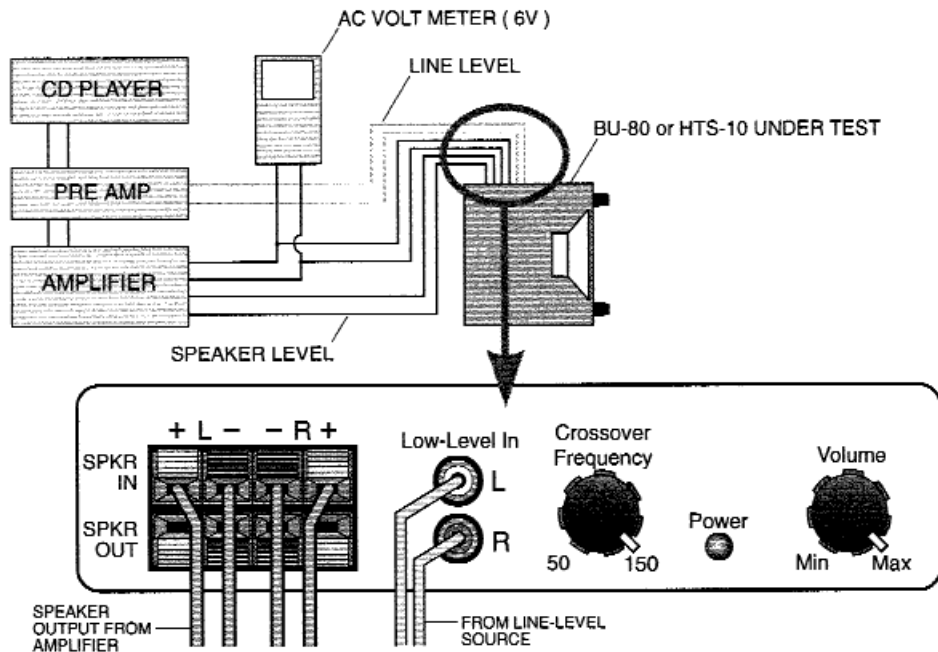

General Function

UUT = Unit Under Test

1. Connect both right and left line level inputs (RCA) to signal generator and UUT. Use Y-cable if necessary from mono source. VOLUME control should be full counterclockwise.
2. Turn on generator, adjust to **50mV, 50 Hz**.
3. Plug in UUT; red LED should be ON. Turn VOLUME control full clockwise.
4. LED should turn Green; immediate bass response should be heard and felt from port tube opening.
5. Turn off generator, turn VOLUME control fully counterclockwise, disconnect RCA cables.
6. Connect one pair of speaker cables to either high level input terminal on UUT. Cables should be connected to an integrated amplifier fed by the signal generator.
7. Turn on generator and adjust so that speaker level output is 2.0V, 50 Hz. Turn VOLUME control full clockwise.
8. Green LED should light, immediate bass response should be heard and felt from the port tube opening.

Sweep Function

1. Follow steps 1-4 above, using a sweep generator as a signal source.
2. Sweep generator from 20Hz to 300Hz. Listen to the cabinet and drivers for any rattles, clicks, buzzes or any other noises. If any unusual noises are heard, remove driver and test.

Driver Function

1. Remove driver from cabinet; detach + and - wire clips.
2. Check DC resistance of driver; it should be **3.4 ohms**.
3. Connect a pair of speaker cables to driver terminals. Cables should be connected to an integrated amplifier fed by a signal generator and adjust so that speaker level output is **5.0V**.
4. Sweep generator from 20Hz to 1kHz. Listen to driver for any rubbing, buzzing, or other unusual noises.

NOTE: When testing the BU80/HTS-10 amplifier, a load must always be connected to the output terminals, whether the woofer, or a 4 to 8 ohm resistive load.

BU80/HTS rev. "A, B"

A. Power Amp Section

1. Resistance Check Resistance from O/P of the module to GND should be >30K (NO LOAD)
 Resistance from V+ of the module to V- of the module should read >5k
 Resistance from V+ of the module to O/P of the module should read >30K
 Resistance from V- of the module to O/P of the module should read >30K
2. Power Up LED RED
3. D.C. Operation

Voltage measurements (DVM)

Between	+6V	V+	O/P	V-	+15V	S/D	FR	I/P	GND	-15V
And	V-	GND	GND	GND	GND	V-	GND	GND	GND	GND
Should be Reading	+6.2V	+38.7v	0V	-38.7V	+15.5V	+5.75V	0V	0V	0V	-15.5V

4. Check Switching Frequency

Use scope (EITHER USES AN ISOLATION TRANSFORMER OR ATTACHES THE PROBE TIP TO SPK- and REFERENCE LEAD TO SPK+)
 -Reading 100kHz +/-10%,1Vpp

B. Pre Amp Section

1. Low Level Input Sensitivity
 -Set up Turn level and Low-Pass Pot Fully CW
 Generator set at 50mV@43Hz
 Signal to Low level input

-Voltage measurements

OP AMP				SPEAKER O/P
U1(1)	U1(14)	U1(7)	U1(8)	
342mV	572mV	2.88V	2.63V	13.6V

2. High Level Input Sensitivity
 -Set up Turn level and Lo Pass Pot Fully CW
 Set Generator at 507mV@43Hz
 Signal to High level input

Voltage measurements 13.6V at speaker output

3. Low-Pass

Set upSet Generator at 100mV@100Hz
 Signal to Low level input
 Measure voltage at speaker output

Voltage measurements

Low-Pass Pot Setting	Output
CW	6.92V
CCW	3.53V

00602-11

4. LED With a 35mV input signal at a single Low level input, LED should change to green

Power Amp Test Procedure Flow Chart BU80/HTS-10 rev. "A, B"

CAUTION : MODULE OUTPUT IS FLOATING AND IS **NOT** PROTECTED AGAINST A SHORT TO GROUND. ALL TEST INSTRUMENTS CONNECTED TO THE OUTPUT **MUST** BE FLOATING. ATTACH THE SCOPE PROBE TIP TO SPK - and REFERENCE LEAD TO SPK+.

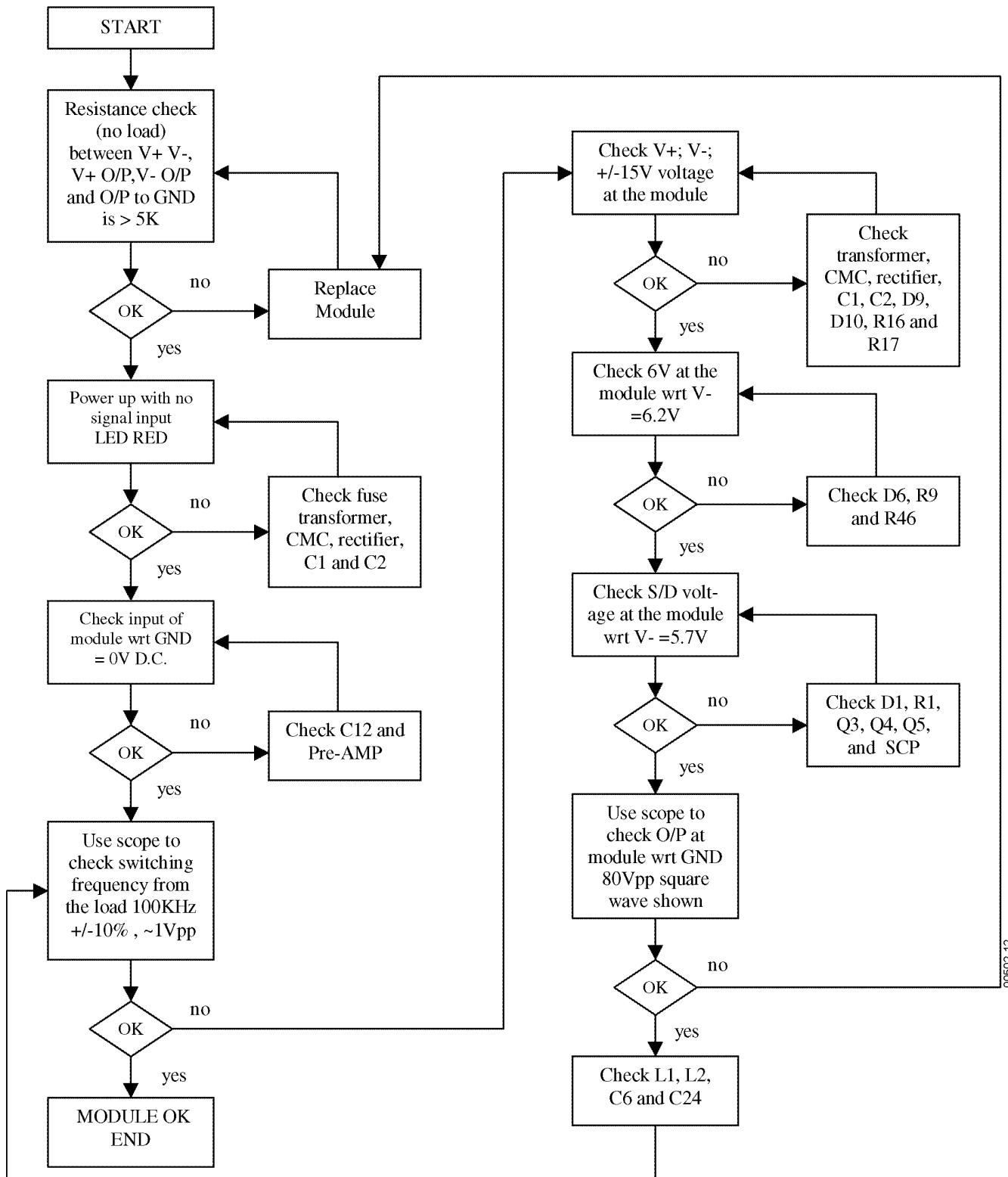

Service Bulletin INF9902 - APRIL 1999

This is considered a Minor repair

To: All Infinity Service Centers

Models: BU-80/HTS-10 (rev. "A,B")

Subject: Check Solder Joints in Event of Failure

Some performance related complaints in the BU-80 powered Subwoofers may be caused by cold solder connections between the 28 pins of the Power Amp Module and the main circuit board. When troubleshooting, failure to check these joints can result in erroneous conclusions or wasted time.

In the event you receive a Subwoofer with the complaints "Dead, or No Output, or Motorboating (Oscillation)", perform the steps listed below first before any further troubleshooting takes place:

- 1) Unplug all cables, lay the subwoofer on a padded surface.
- 2) Remove all Philips screws around the outer perimeter of the amplifier faceplate.
- 3) Remove amplifier assembly; you should be able to remove the amplifier far enough out of the cabinet to service it without removing the woofer wires.
- 4) Locate the Power Amp Module; it is the large gray component with a metal case. On the solder side of the circuit board are the 28 soldered connections to the Module.
- 5) Regardless of whether you can visibly see breaks in any of the connections or not, carefully re-solder all 28 pin connections, adding 60/40 rosin core solder. Take care not "bridge" any connections on the board with solder.
- 6) Inspect the solder joints to the main filter capacitors C1 and C2 on the main PCB and re-solder if needed.
- 7) Replace the amplifier assembly back into the cabinet; replace the screws.
- 8) Test the unit by applying a signal from a music source, adjust the volume to a moderate level and confirm the original problem has been corrected.

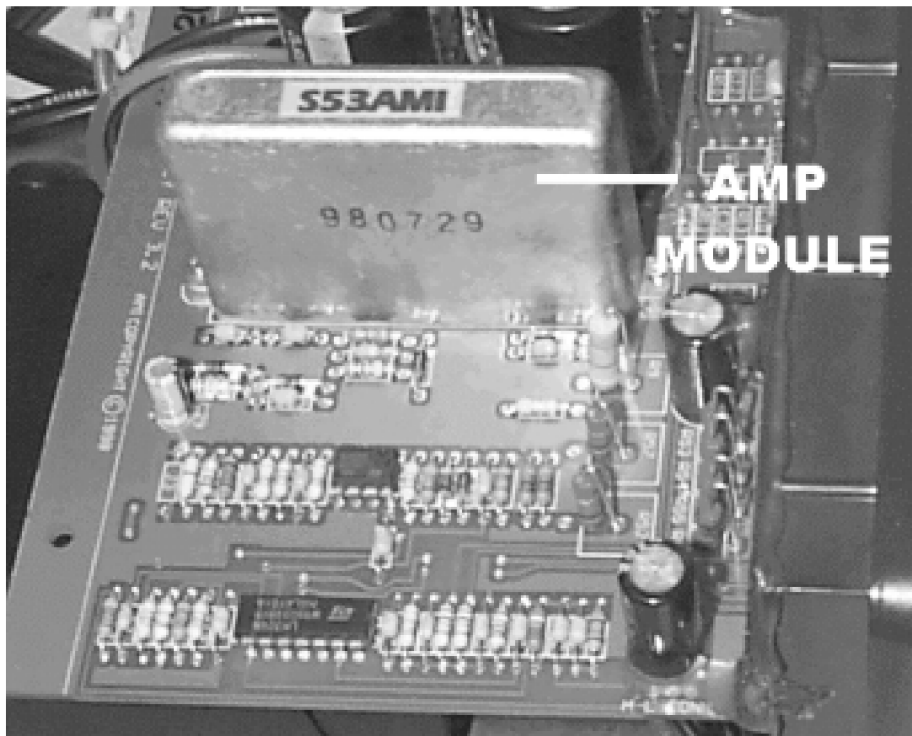

00502-13



Service Bulletin

Service Bulletin INF2000-01 Rev2 - February 2001

Warranty labor rate: MINOR repair

To: All Infinity Service Centers

Models: BU80, BU120, HTS-10 revA, HTS-20 revA subwoofers

Subject: Failure of C6

In the event you receive a BU80, BU120, HTS-10 or HTS-20 subwoofer with the complaint “no output” and capacitor C6 (10uf 50v NPE) is damaged in the amplifier:

Order kit Infinity part# 30722 and replace the following included parts:

- C6 – (10uf 100v NPE cap) C24 – (100nF 50v cap) R46 – (47 1/4W resistor)
- R23 – (20k 1/2W resistor – used only on models BU120, HTS-20 revA)

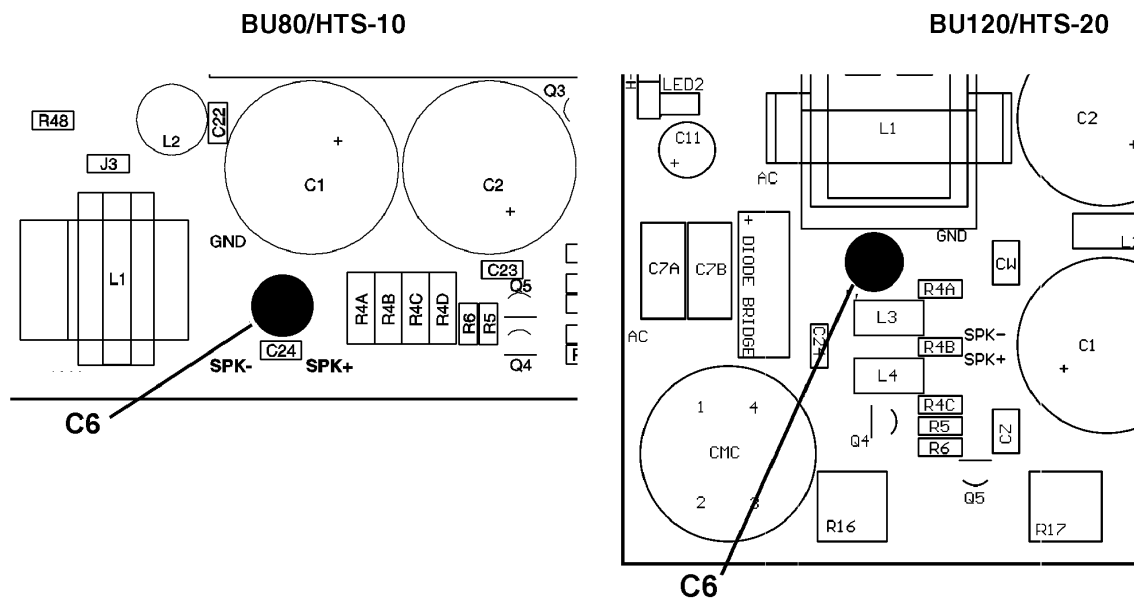

General reference for location only; not all parts or designators may conform to these drawings.

FOLLOWING THE REPAIR:

Follow instructions included in bulletin #INF9902.

IMPORTANT SERVICE NOTES: When testing the BU or HTS Series amplifier, a load must always be connected to the output terminals, whether the woofer, or a 4 to 8 ohm resistive load. All AC powered test instruments (meters, oscilloscopes, etc.) must have a floating ground, i.e. be connected to an isolation transformer.

Models	Serial number 120/230V	Status	Action
BU80 BU120 HTS-10 revA HTS-20 revA	All serial numbers affected	Replace if damaged	Replace C6,R23, C24, R46 with Infinity part# 30722

SERVICE BULLETIN INF2000-02 - MARCH 2000

Warranty labor rate: MINOR repair

To: All Infinity Service Centers

Model: BU-80/HTS-10 (rev. "A,B")

Subject: Blowing fuses

Early versions of the BU80 subwoofer, if driven near maximum output for an extended period of time, may repeatedly blow the internal line fuse.

In the event you receive a BU80 or HTS-10 subwoofer with the complaint "no output" or "dead", and fuse F1 (0.5A) is blown, and has blown more than once in the past,* replace the following new parts:

F1: 1.0A 250v T type fuse, Infinity part# 80111

T1: Power transformer #4300F, Infinity part# 80127

Fuse Label, Infinity part# 80127A

After the part replacement, affix the new fuse label to the amplifier faceplate, covering up the former label.

CAUTION: All parts must be replaced at the same time; do NOT attempt to just replace original fuse F1 (0.5A) with the new 1.0A rated fuse alone, without replacing original power transformer #4300.

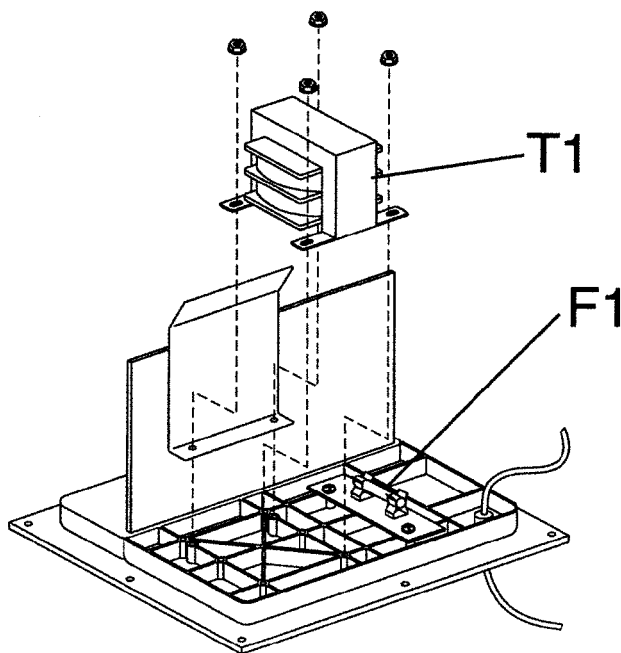

* This bulletin defines "blown fuses" as: fuse F1 blowing when the unit is powered up and has played normally for several minutes or more. If the unit is blowing fuse F1 instantly upon power-up, chances are another problem is involved, and the instructions in this bulletin will not help. For this condition, see Bulletins #INF9902, #INF2000-01, and obtain the BU80/HTS-10 service manual.

Models	Serial number 120/230V	Status	Action
BU80 HTS-10	#AM0011-29474 and below #AM0011-07400 and below	Has blown F1 fuse more than once. Faceplate labeled 0.5A	Replace: F1 Fuse T1 Transformer Fuse Label
BU80 HTS-10	#AM0011-29475 and above #AM0011-07401 and above	Changed by Factory Faceplate labeled 1.0A	NONE REQUIRED

00502-15

TECH TIPS

Troubleshooting tips and solutions to common service problems

For models: BU80/HTS-10

TIP# INFTT2000-01

Complaint:

How do you replace or service any of the front panel components on the Subwoofer faceplate for model BU80/HTS-10.

Probable Cause:

The High level Input terminals, potentiometers and RCA jack are behind a sealed cover to protect the air-tight integrity of the cabinet enclosure.

Solution:

- 1) Unplug all external cables from the subwoofer; place the cabinet on a padded surface.
- 2) Remove any subwoofer grille; remove the woofer from the cabinet. Detach the two connections from the woofer terminals.
- 3) Remove all Phillips screws holding the amplifier to the cabinet; remove the amplifier.
- 4) Remove all knobs, nuts, and Philips screws from the outer control section of the amplifier faceplate.
- 5) Locate the sealed cover on the inside of the amplifier faceplate (see illustration); the bead of adherent must be broken to remove the main PCB with front panel components from the plastic faceplate. This is most easily accomplished by CAREFULLY using a box cutter, exacto knife, or similar sharp instrument. First scrape all excess material from the three surfaces; then force the blade into the groove between the rear cover and the faceplate. DO NOT attempt to remove the rear cover from the main PCB.
- 6) When enough material is removed, the main PCB with cover should pull away from the faceplate, exposing the components.
- 7) After servicing a bead of silicon seal or similar adherent must be applied to all surfaces where it was removed. Reassemble the rest of the components in reverse order.

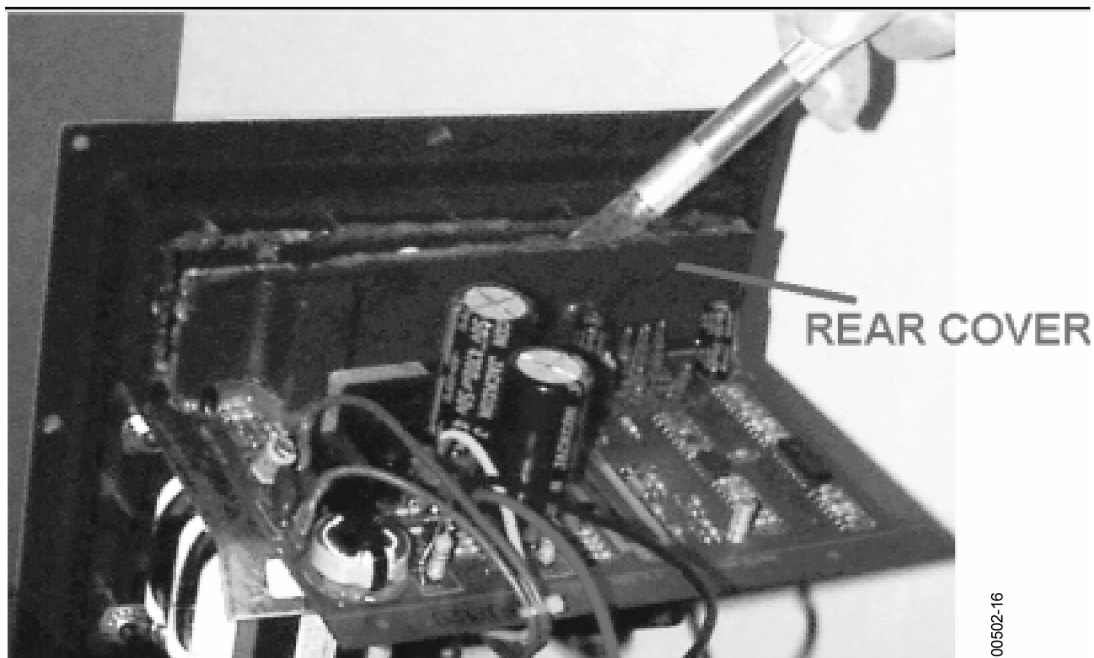

00502-16

BU-80/BU80E/HTS-10 AMPLIFIER ASSEMBLY EXPLODED VIEW

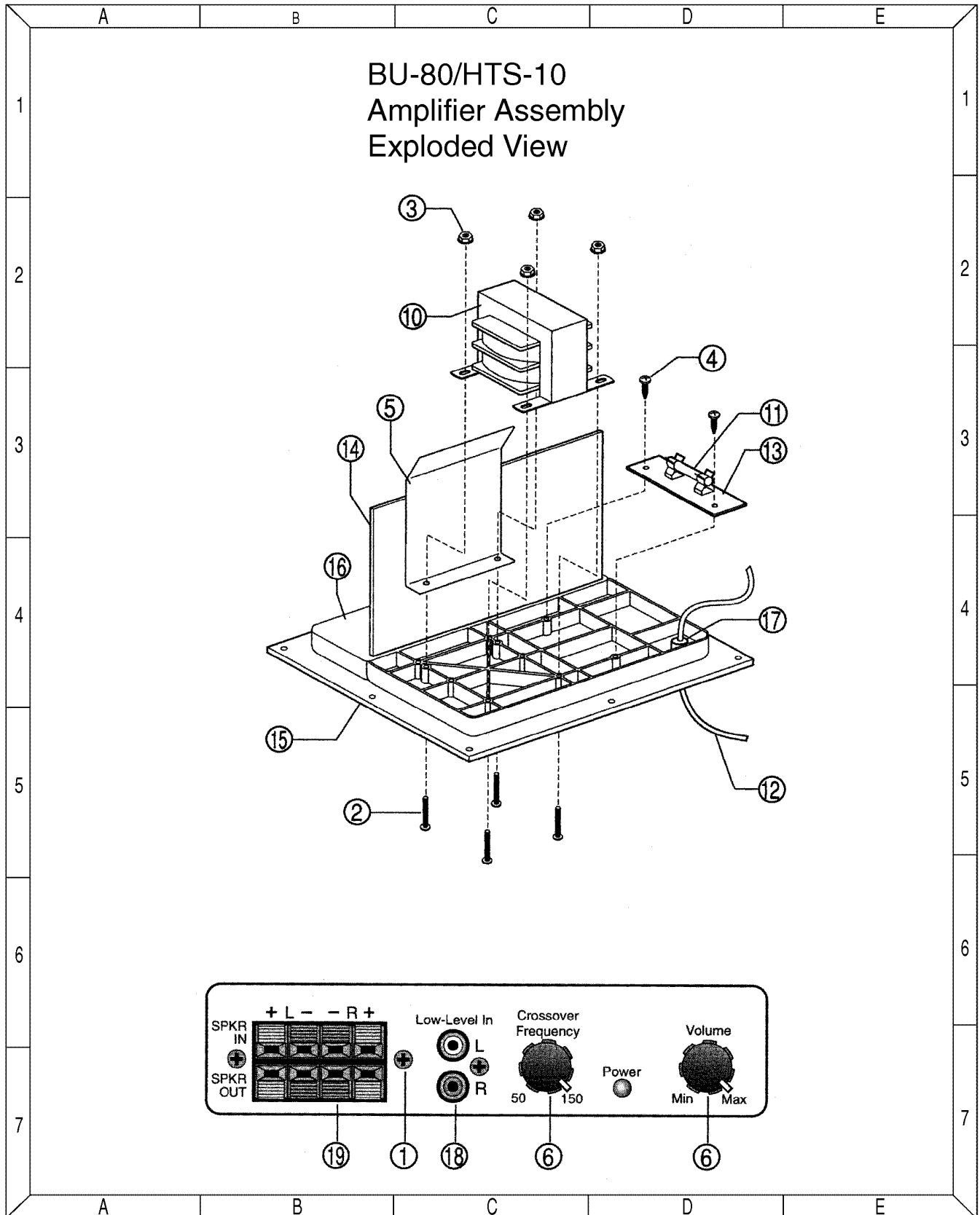

00502-17

BU-80/BU80E/HTS-10 AMPLIFIER ASSEMBLY EXPLODED VIEW (Cont.)

Ref#	Part#	Description	Qty
1	70170	#4x0.5" screws to secure input jacks	3
2	70171	#10 x 1" machine screw bolts for 4transformer 4 per unit	4
3	70172	#10 keps nuts for transformer	4
4	70173	#6 x 0.5" screws for fuse PCB	2
5	70301	Hum Shield Metal bracket mounted on transformer BU-80 and HTS-10 rev "A,B" ONLY	1
6	A70302 V	Volume Control/Crossover Knob BU-80 and HTS-10 rev "A,B" ONLY	2/1
6	061-020000-000	Volume Control Knob HTS-10 rev "C" ONLY	1
10	80103	T1 Transformer #4300 SAFETY PART BU-80 and HTS-10 rev "A," ONLY	1
10	80127	T1 Transformer #4300F SAFETY PART BU-80 and HTS-10 rev "B" ONLY	1
10	042-017607-004	T1 Transformer SAFETY PART HTS-10 rev "C" ONLY	1
11	80104 or 870-0226	F1 Fuse 250V, 0.5A, T type slo blo fuse SAFETY PART BU-80 and HTS-10 rev "A" ONLY	1
11	80111	F1 Fuse 250V, 1.0A, T type slo blo fuse SAFETY PART BU-80 and HTS-10 rev "B" ONLY	1
11	091-000097-000	F1 Fuse 250V, 1.0A, T type slo blo fuse SAFETY PART HTS-10 rev "C" ONLY	1
12	80105	Power cord, 2 conductor SAFETY PART BU-80 and HTS-10 rev "A,B" ONLY	1
12	083-041802-017	Power cord, 2 conductor SAFETY PART HTS-10 rev "C" ONLY	1
13	80106	Fuse PCB complete with connectors SAFETY PART BU-80 and HTS-10 rev "A,B" ONLY	1
13	011-080203-000	Fuse PCB complete with connectors SAFETY PART HTS-10 rev "C" ONLY	1
14	80107	Main PCB SAFETY PART BU-80 and HTS-10 rev "A,B" ONLY	1
14	015-161000-102	Main PCB SAFETY PART HTS-10 rev "C" ONLY	1
15	200203	Faceplate with labels SAFETY PART	1
16	A70304	Air leak cover SAFETY PART	1
17	70305	Pwr cord strain relief SAFETY PART BU-80 and HTS-10 rev "A,B" ONLY	1
17	061-314002-000	Pwr cord strain relief SAFETY PART HTS-10 rev "C" ONLY	1
18	108320	Dual RCA input jacks BU-80 and HTS-10 rev "A,B" ONLY	1
18	072-010058-000	Dual RCA input jacks HTS-10 rev "C" ONLY	1
19	108115	High level Input and Output terminals BU-80 and HTS-10 rev "A,B" ONLY	1
19	062-050800-000	High level Input and Output terminals HTS-10 rev "C" ONLY	1

00502-18

BU-80/BU-80E/HTS-10 PACKING & CABINET PARTS

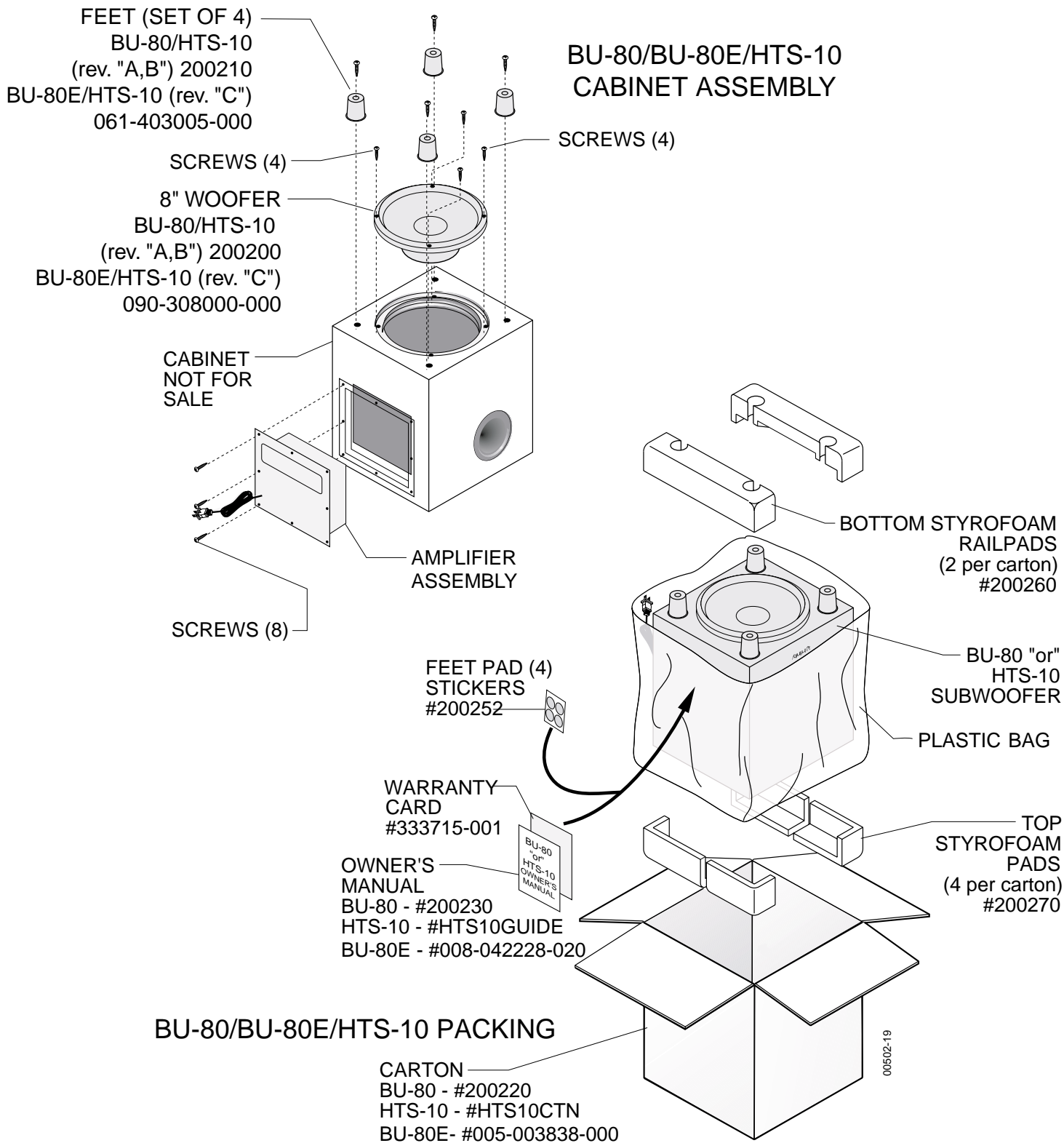

NOTE: The HTS-10 subwoofer is part of the HTS-10 system and packaged with 5 satellite speakers; the master carton is not shown.

BU-80/HTS-10 (rev. A, B) PCB

The PLAIN 5 PCB was used in early 120V versions only

PLAIN 5 - Component Side Trace

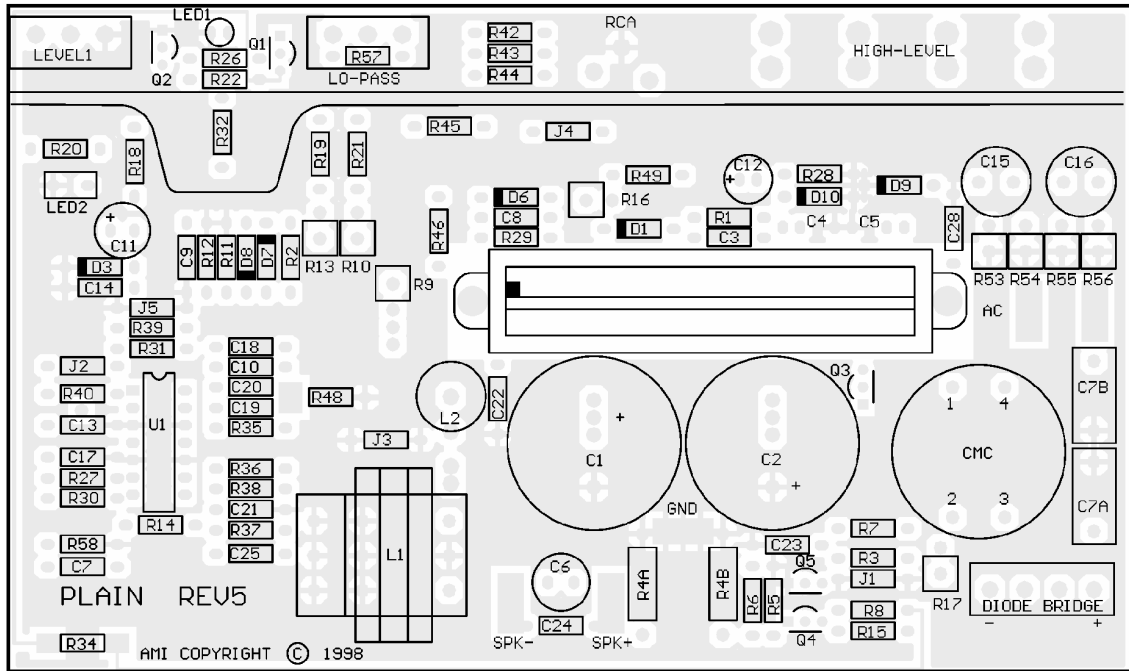

PLAIN 5 - Solder Side Trace Layer as viewed through the board

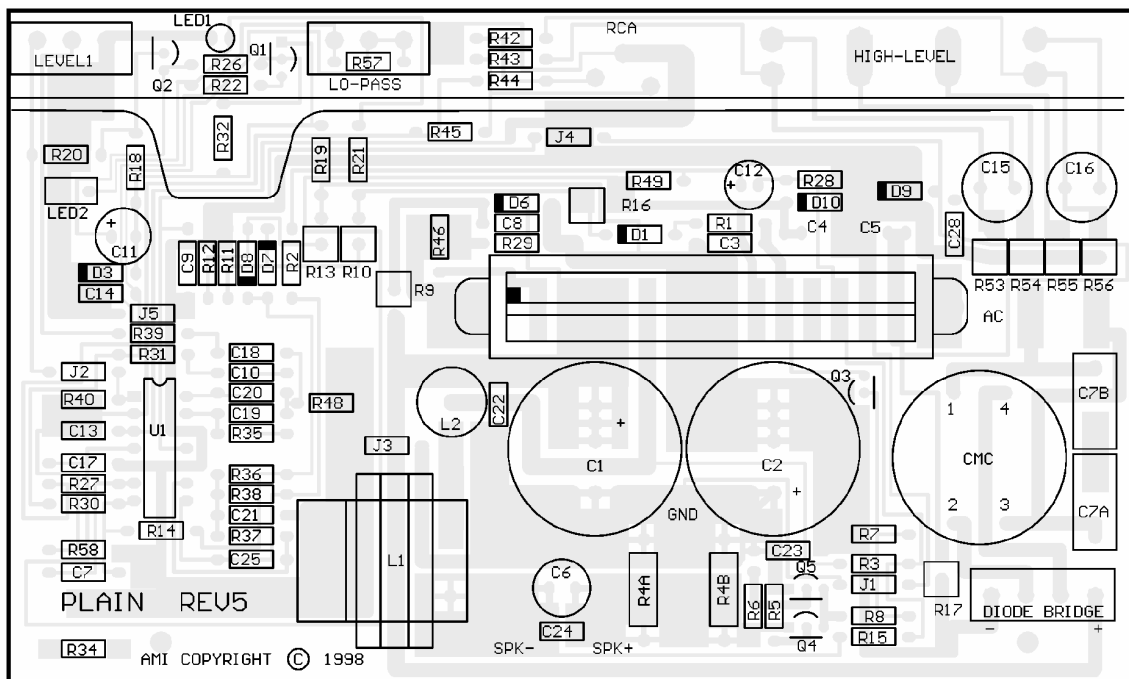

BU-80/HTS-10 (rev. A, B) PCB

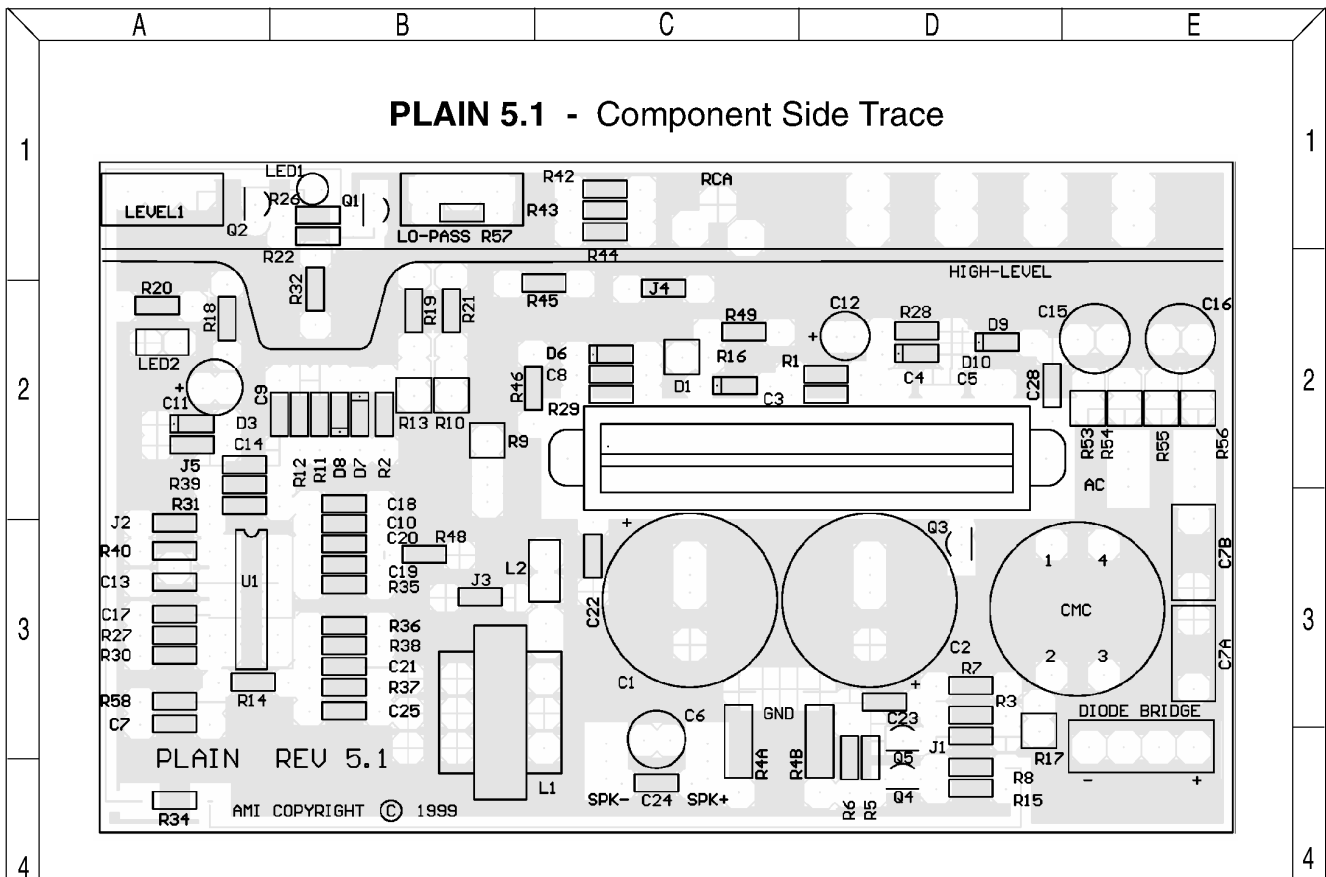

PLAIN 5.1 - Solder Side Trace Layer as viewed through the board

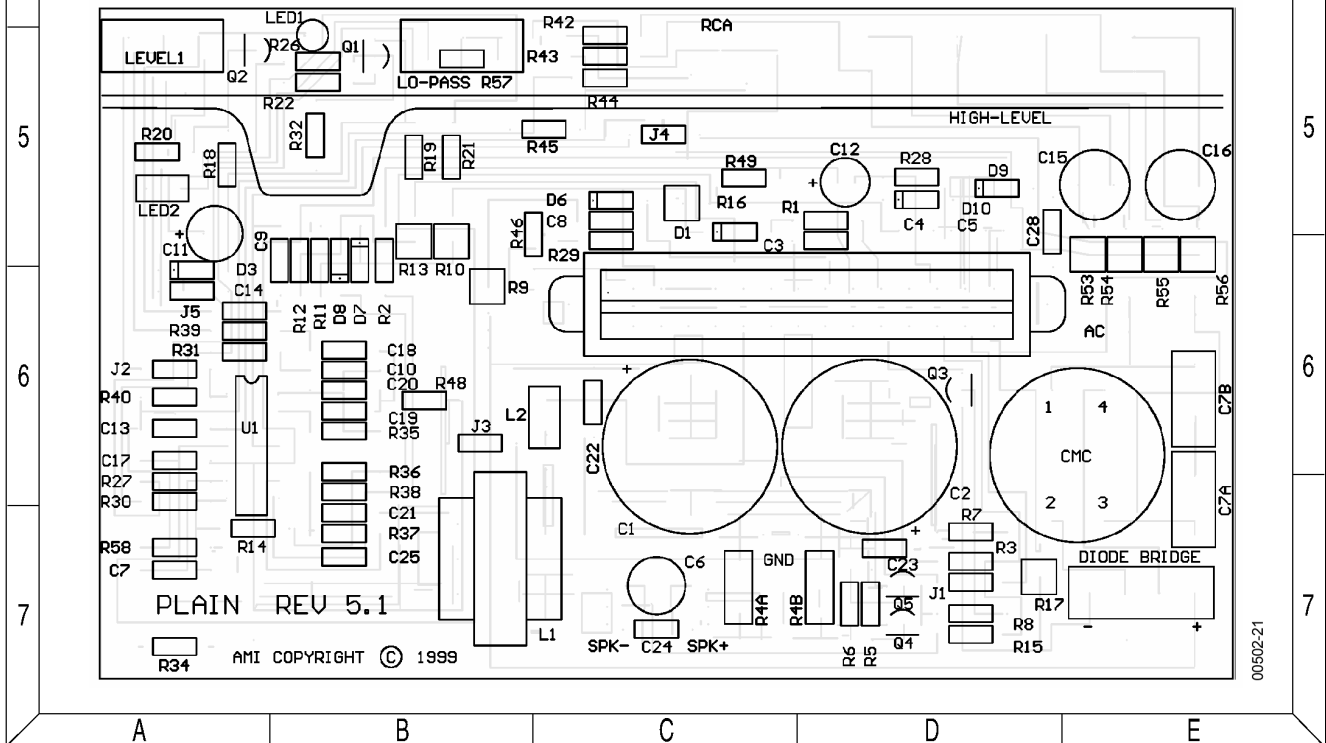

BU-80/HTS-10 (rev. A, B) ELECTRICAL PARTS LIST

REF#	PART#	DESCRIPTION	QTY	REF#	PART#	DESCRIPTION	QTY
Capacitors				R35	40416	221k 1/4W 1% metal film	1
C1, 2	30701	3300uF 50V □20% Electrolytic Radial SAFETY PART	2	R36	40406	100k 1/4W 5% carbon film	1
C3	30504	100nF 50V 10% Mono-ceramic axial	1	R37	40417	47k 1/4W 5% carbon film	1
C4, 5	30502	100nF 50V 20% Mono-cer rad 0.2"ax 0.3"	2	R38	40406	100k 1/4W 5% carbon film	1
C6	30705	10uF 50V 20% Electrolytic Radial NP SAFETY PART See page 15 (ServiceBulletinINF2000-01)	1	R39	40448	28k 1/4W 5% carbon film	1
C7	30503	2.2nF 50V 10% Mono-ceramic axial	1	R40	40431	68k 1/4W 5% carbon film	1
C8, 10	30504	100nF 50V 10 Mono-ceramic axial	2	R42, 43	40406	100k 1/4W 5% carbon film	2
C9	30502	100nF 50V 20% Mono-ceramic axial	1	R44, 45	40409	10k 1/4W 5% carbon film	2
C11	30702	100uF 35V 20% Electrolytic Radial	1	R46	40104	4.7 1/4W 5% carbon film	1
C12	30703	4.7uF 35V 20% Electrolytic Radial	1	R48	40428	8.2k 1/4W 1% metal film	1
C13	30506	1nF 50V 10% Mono-ceramic axial	1	R49	40431	68k 1/4W 5% carbon film	1
C14	30504	100nF 50V 10% Mono-ceramic axial	1	R4A, 4B	40105	0.1 1/2W 5% 2pcs.	2
C15, 16	30704	220uF 50V 20% Electrolytic Radial Bipolar	2	R53, 54, 55, 56	40106	100 2W 5% carbon film	4
C17	30502	100nF 50V 20% Mono-ceramic axial	1	R57	40406	100k 1/4W 5% carbon film	1
C18, 19, 20	30504	100nF 50V 10% Mono-ceramic axial	3	FRQ pot	40401	100k 1/4W 10% Single Log Pot	1
C21	30508	10nF 50V 10% Mono-ceramic axial	1	VOL Level pot	40402	5k 1/4W 10% Single Linear Pot	1
C24	30502	100nF 50V 20% Mono-ceramic axial	1	Diodes			
C25	30503	2.2nF 50V 10% Mono-ceramic axial	1	D1	50101	ZENER 1N5256B 30V 5% 0.5W	1
C28	30507	10nF 50V 20% Mono-ceramic axial	1	D3	50102	ZENER 1N4749A 24V 5% 1W	1
C7A, 7B	30505	100nF 100V 20% Metal Polyester Rad	2	D6	50103	ZENER 1N5234B 6.2V 5% 0.5W	1
Resistors				D7, 8	50104	1N4148 100V 5% 0.1A	2
R1	40403	2200k 1/4W 5% carbon film	1	D9, 10	50105	ZENER 1N4744A 15V 5% 1W	1
R2	40447	4.32k 1/4W 1% metal film	1	DBR	50100	Bridge Rect 200V 4A SAFETY PART	1
R3	40412	33.2k 1/4W 1% metal film	1	LED 1 or 2	50106	Dual Cir LED (2 legged)	2
R5, 6	40420	1k 1/4W 5% carbon film	2	Integrated Circuit			
R7	40409	10k 1/4W 5% carbon film	1	U1	60100	LM324 Quad OpAmp +/-15%	1
R8	40406	100k 1/4W 5% carbon film	1	S53AMI	60301	Power Amp module SAFETY PART	1
R9	40421	3.9k 5W 5%, 3W can be used	1	Transistors			
R10	40404	1k 2W 5% carbon film	1	Q1	60151	MPS A13 30V NPN(Darl) Transistor	1
R11, 12	40107	150 1/2W 5% carbon film	2	Q2	60152	2N3906 40V PNP Transistor	1
R13	40404	1k 2W 5% carbon film	1	Q3	60153	2N3904 40V NPN Transistor	1
R14	40405	4.7k 1/4W 5% carbon film	1	Q4, 5	60154	MPS A56 80V PNP Transistor	2
R15	40406	100k 1/4W 5% carbon film	1	Miscellaneous			
R16, 17	40101	820 2W 5% carbon film	2	CMC1	80100	mc4438 Neosid 28-523C36 2X 2.2mH #23 awg @ 2X 24 SAFETY PART	00502-22
R18	40423	270k 1/4W 5% carbon film	1	L1	80101	mc4436 Neosid 32-192-44 200uH #18SNSR @ 3 6 SAFETY PART	
R19	40422	1k 1/2W 5% carbon film	1	L2	80102	BL02RN2-R62	
R20	40405	4.7k 1/4W 5% carbon film	1				
R21	40409	10k 1/4W 5% carbon film	1				
R22	40449	3.3k 1/2W 5% carbon film	1				
R26	40701	1000k 1/4W 5% carbon film	1				
R27	40411	24.9k 1/4W 1% metal film	1				
R28	40409	10k 1/4W 5% carbon film	1				
R29	40103	470 1/4W 1% METAL SAFETY PART	1				
R30	40413	274k 1/4W 1% metal film	1				
R31	40414	49.9k 1/4W 1% metal film	1				
R32	40415	470k 1/4W 5% carbon film	1				

BU-80/HTS-10 INTEGRATED CIRCUIT/TRANSISTORS DIAGRAM

S53AM/S64AMI - Power Amp module SAFETY PART

BU-80 and HTS-10 rev "A, B" ONLY

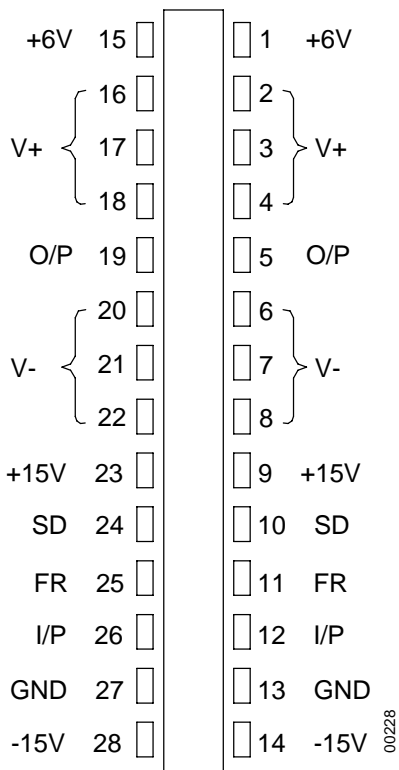

NOTE: THE FOLLOWING PROCEDURES MUST BE FOLLOWED WHEN INSTALLING NEW AMP MODULES:
FAILURE TO FOLLOW ONE OR MORE OF THESE STEPS MAY RESULT IN THE INSTANT DESTRUCTION OF THE MODULE WHEN POWERED UP.

- 1) Align white indent marker on Amp Module with indent marker on main PCB; alternately position of label on the top of the module; incorrectly replacing the Module 180° in the PCB slot will result in its destruction.
- 2) All AC powered test instruments (meters, oscilloscopes, etc.) must have a floating ground, i.e. be connected to an isolation transformer.
- 3) Align and position the Amp Module before soldering.
- 4) Attach the amp Module with the mounting screws before soldering or powering up.
- 5) Use only rosin-core or non-acid core solder; thoroughly de-flux the surfaces after soldering.

If the new Amp Module has larger mounting hole(s) in the case, and the stock screws no longer will fit, and screws of the proper type cannot be obtained locally order:

(2) part# 60301S (screws)

(2) part# 60301N (nuts)

QUAD OP AMP, LM324, TL074 U1, IC101

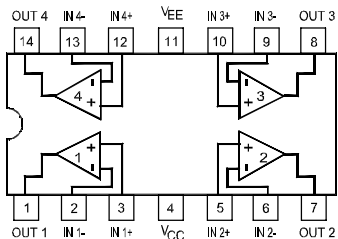

BU-80E & HTS-10 rev "C" ONLY

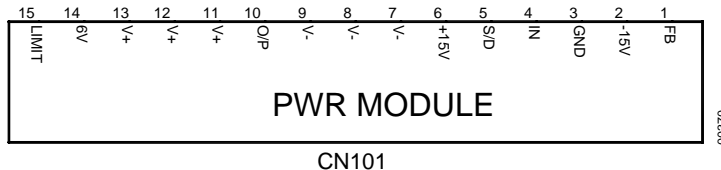

TRANS, NPN
MPS A13 (Darl)
Q1

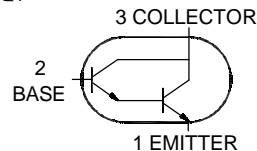

MOSFET TRANS
IRF530
Q2, 3

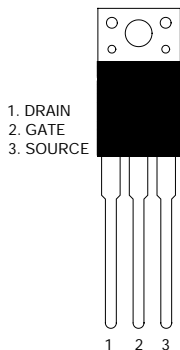

TRANS, PNP, 2SA1015
Q101, 104, 105

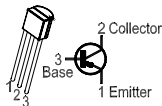

TRANS, PNP, 2N3906
MPS A56
Q2, 4, 5

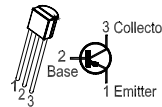

TRANS, NPN, KSP113
2SC1815
Q102, 103

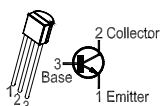

TRANS, NPN, 2N5551
2N3904
Q1, 3

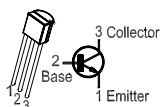

IC 74HC14N HEX SCHMITT
TRIGGER INVERTER
U2, 3

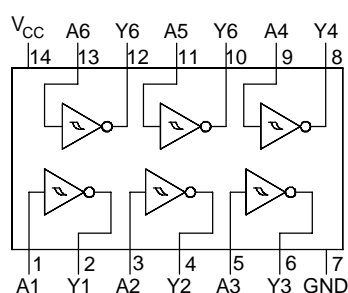

JFET DUAL OPAMP
LF353N U1

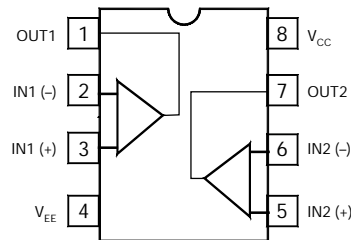

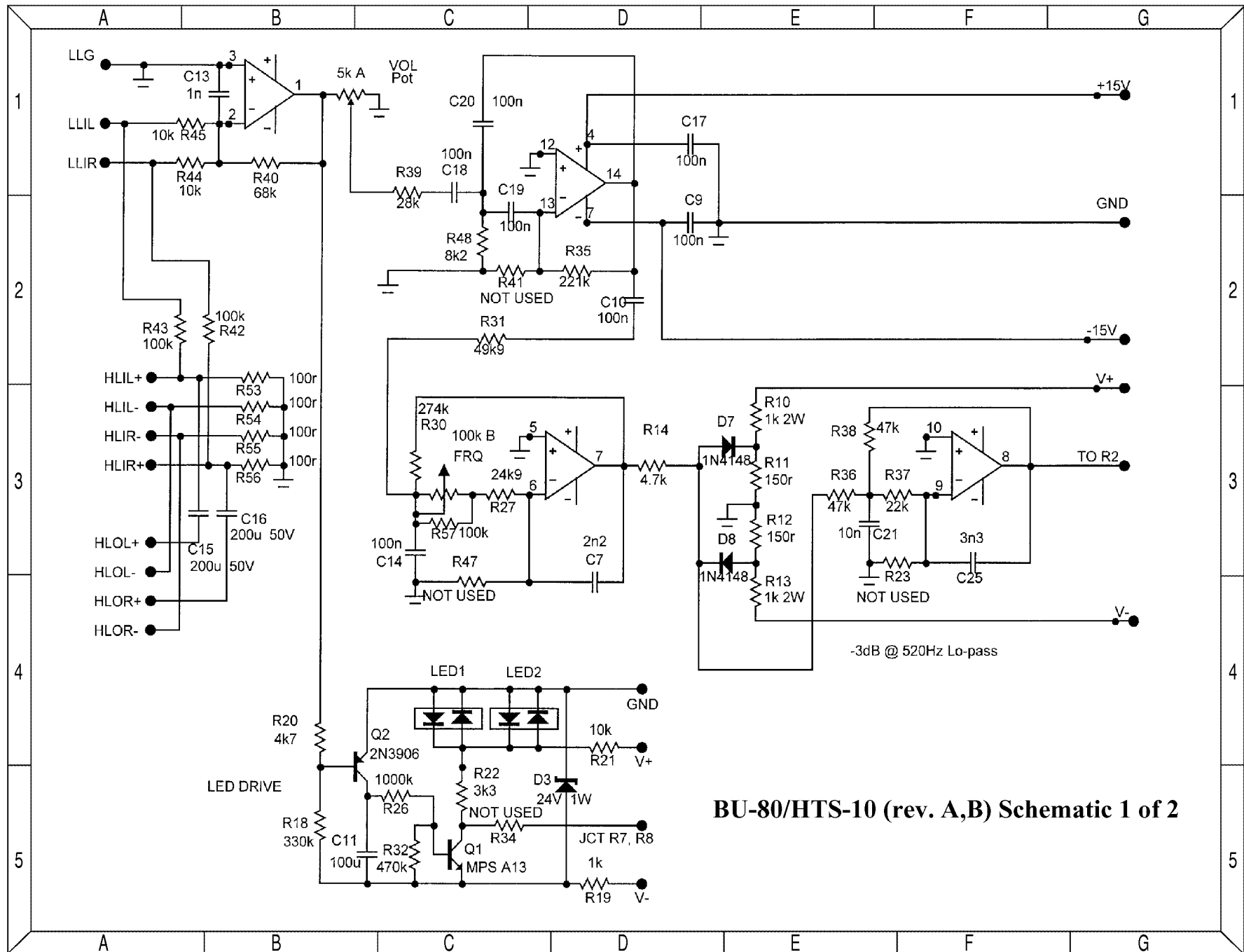

BU-80/HTS-10 (rev. A,B) Schematic 1 of 2

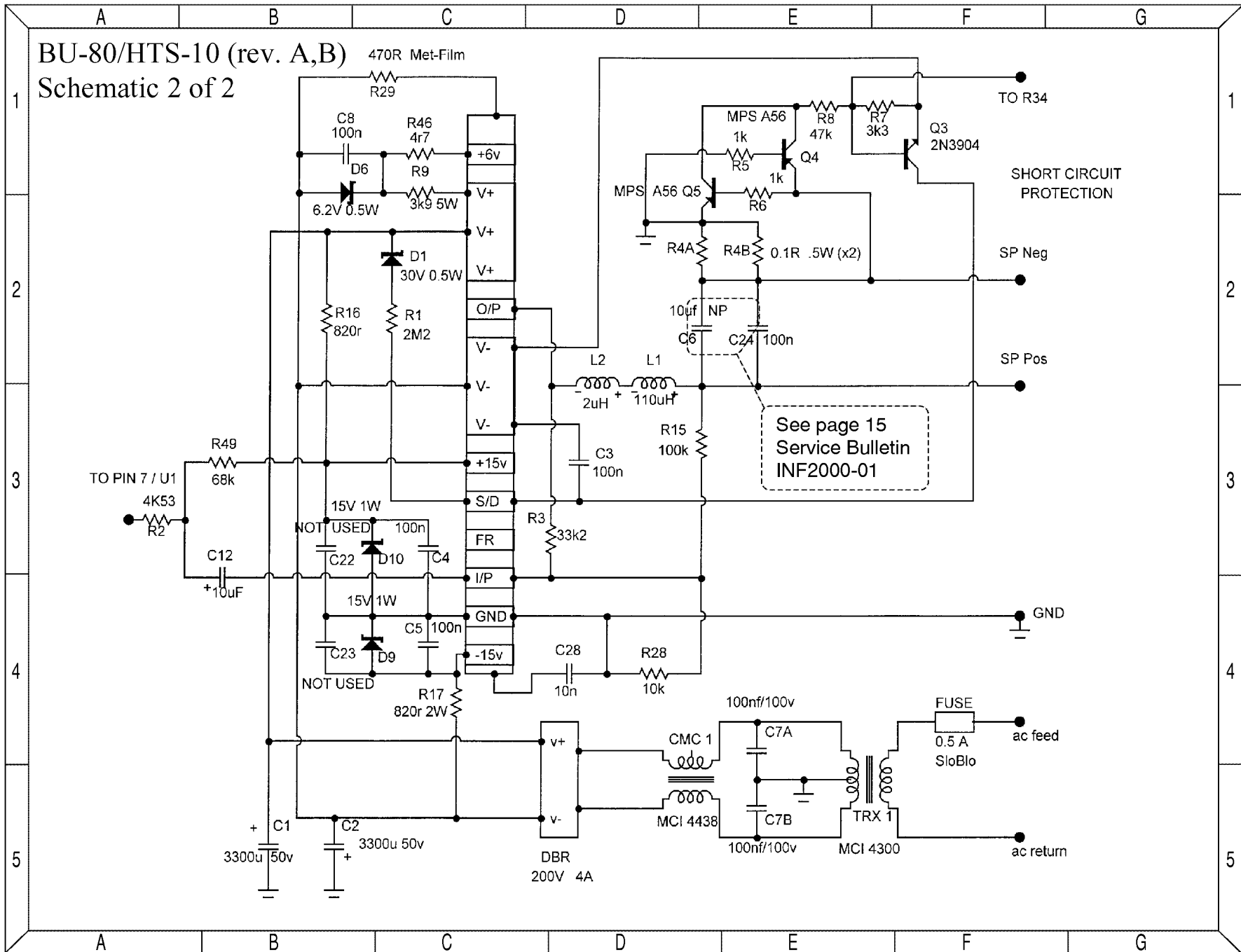

HTS-10 ELECTRICAL PARTS LIST (Rev C version)

Part Number	Description	Ref. Designator	Qty
MAIN PCB			
Semiconductors			
050-002400-100	ZENER DIODE 24V	D103	1
050-003000-100	ZENER DIODE 30V	D104	1
050-006200-100	ZENER DIODE 6.2V	D002	1
050-414802-100	1N4148 DIODE	D101,102,105,106	4
050-524500-200	ZENER DIODE 15V/1W	D003,004	2
051-001300-100	TRANSISTOR KSP113	Q102	1
051-101501-000	TRANSISTOR 2SA1015	Q101,104,105	3
051-181501-100	TRANSISTOR 2SC1815	Q103	1
052-401001-000	KBU4A/100V Bridge Regulator	D001	1
053-007400-000	IC TL074 Dual Op-Amp	IC101	1
Resistors			
020-100497-120	Carbon resistor 1K 1/4W J	R132,139,140	3
020-100597-120	Carbon resistor 10K 1/4W J	R107,108,R131,133,136	5
020-100697-120	Carbon resistor 100K 1/4W J	R105,106,114,122,124,134,137	7
020-100797-120	Carbon resistor 1M 1/4W J	R128	1
020-220797-120	Carbon resistor 2M2 1/4W J	R138	1
020-330397-120	Carbon resistor 330R 1/4W J	R118,119	2
020-330497-120	Carbon resistor 3K3 1/4W J	R130	1
020-330597-120	Carbon resistor 33K 1/4W J	R135	1
020-430497-121	Carbon resistor 4K3 1/4W J	R125	1
020-470197-121	Carbon resistor 4R7 1/4W J	R002	1
020-470497-120	Carbon resistor 4K7 1/4W J	R117	1
020-470597-120	Carbon resistor 47K 1/4W J	R123	1
020-470697-120	Carbon resistor 470K 1/4W J	R129	1
020-680597-120	Carbon resistor 68K 1/4W J	R109,143	2
021-100096-120	MOF RESISTOR 0R1 1/2W	R141,142	2
021-100301-120	MOF RESISTOR 100R/1W	R101-104	4
021-220401-021	MOF RESISTOR 2K2 1W	R120,121	2
021-220402-020	MOF RESISTOR 2K2 2W	R001	1
021-221597-100	MF RESISTOR 221K 1/4W F	R112	1
021--249597-100	MF RESISTOR 24K9 1/4W F	R115	1
021-270697-100	MF RESISTOR 270K 1/4W F	R127	1
021-274697-100	MF RESISTOR 274K 1/4W F	R116	1
021-280597-100	MF RESISTOR 28K 1/4W F	R110	1
021-470497-100	MF RESISTOR 4K7 1/4W F	R126	1
021-499597-100	MF RESISTOR 49K9 1/4W F	R113	1
021-820302-020	MO 820OHM/2W	R003,004	2
021-820497-100	MO 8K2 OHM/1W	R111	1
026-100695-251	VR 100KB Crossover Frquency Pot	VR102	1
026-500495-252	VR 5K ohm Volume Pot	VR101	1
Capacitors			
030-100247-300	Ceramic capacitor 0u1/50V Z P:5	C114,115,006,009,010	5
032-100163-300	mylar capacitor 0u001/100V J P:5	C103	1
032-100263-301	mylar capacitor 0u01/100V J P:5	C110	1
032-100364-300	mylar capacitor 0u1/100V K R	C001,002,003,007,008, 104105106107108, 118	11
032-180364-300	mylar capacitor 0u18/100V J P:5	C116	1
032-220163-300	mylar capacitor 0u0022/100V J P:5	C109,111	2
033-220543-200	elec capacitor 22uF/50V J6R 1020	C117	1
033-220644-281	NPE capacitor 220uF/50V K10R1326 VIE	C101,102	2

Part Number	Description	Ref. Designator	Qty
034-100635-300	elec capacitor 100uF/35V MR 0811 P5	C113	1
034-330745-310	elec capacitor 3300uF/50V MR 1840 P7.5	C004,005	2
034-470425-300	elec capacitor 4u7/25V MR 0511 P5	C112	1
	POWER AMP MODULE		1
050-414802-100	1N4148 DIODE	D1-D9	9
051-530000-100	MOSFET N-CHANNEL IRF530	Q2,3	2
051-555100-000	TRANSISTOR 2N5551	Q1	1
053-035301-000	IC LF353N Dual Op-Amp	U1	1
053-741400-000	IC 74HC14N Hex Schmitt Trigger Inverter	U2,3	2
020-100297-120	Carbon resistor 10R 1/4W J	R11,12	2
020-100397-120	Carbon resistor 100R 1/4W J	R7	1
020-100497-120	Carbon resistor 1K 1/4W J	R3,4,5,9	4
020-100697-120	Carbon resistor 100K 1/4W J	R2	1
020-100797-120	Carbon resistor 1M 1/4W J	R10	1
020-220397-121	Carbon resistor 220R 1/4W J	R6	1
020-330497-120	Carbon resistor 3K3 1/4W J	R8	1
020-680497-120	Carbon resistor 6K8 1/4W J	R1	1
032-100394-302	MND mylar capacitor 0u1/100V K P:7.5	C9	1
034-100525-303	elec capacitor 10uF/25V M SM 4*7	C7	1
039-100343-100	mylar capacitor(axial) 100pF/50V J NPO	C1,2,3,5	4
039-100345-100	mylar capacitor(axial) 0u1/50V M Z5U	C4	1
039-100464-100	mylar capacitor(axial) 0u001/50V K X7R	C8	1
039-330344-101	mylar capacitor(axial) 330pF/50V K X7R	C6	1
072-040170-000	CONNECTOR 15PIN		1
073-014023-900	SHIELD 103.9*14*0.3t		1
073-032050-000	HEAT SINK 102.3*58mm		1
061-700012-000	Silicon Sleeves for Q2, Q3		2
FUSE PCB ASS'y			
011-080203-000	FUSE PCB BOARD SWD80 82*21*1.6m/m		
072-040039-000	Terminal (PCB TYPE) PC205 (t=0.8mm)	J3,4,5,6	4
091-000097-000	FUSE T1A/250V 5*20mm		1
091-000130-000	FUSE HOLDER CQ-203SP(C) (0)		
Miscellaneous			
042-017607-004	Transformer YT-9161-2 75W-120Vac		1
073-014026-000	Metal Shield Plate		1
061-020000-000	knob 20x15mm ul94V-0		1
061-314002-000	cord bushing P/N SB4F-2		1
062-160400-001	Rear cover 168.6x36.8x19.9mm		1
062-211800-000	Front cover 213x178x31.5mm		1
083-041802-017	power cord spt-2 blk #18		1
043-240130-010	CHOKE COIL 2.4mH YT-8719	L001	1
043-260330-001	CHOKE COIL 0.11mH YT-8713-1	L104	1
050-505200-001	LED LT-2402-25	LED101	1
008-061007-200	GASKET MODULE BLK CR C4305 1x7x80mm		1
008-061610-201	GASKET PCB PU FOAM SM-55 3x6x200mm		1
062-050800-000	PUSH TERMINAL 8P	JK101	1
070-560891-108	SCREW BTS-3 2.6x8m/m		
072-010058-000	RCA JACK 2P P/N:052000W1G (Red,Wht)	JK102	1
072-040032-000	Terminal P:3.96 3P	CN001	1
072-040039-000	Terminal PCB TYPE PC205 (t=0.8mm)	J101,102	2
091-000143-000	EMI BEAD		2

BU80E/HTS-10 REV C POWER AMP MODULE PCB

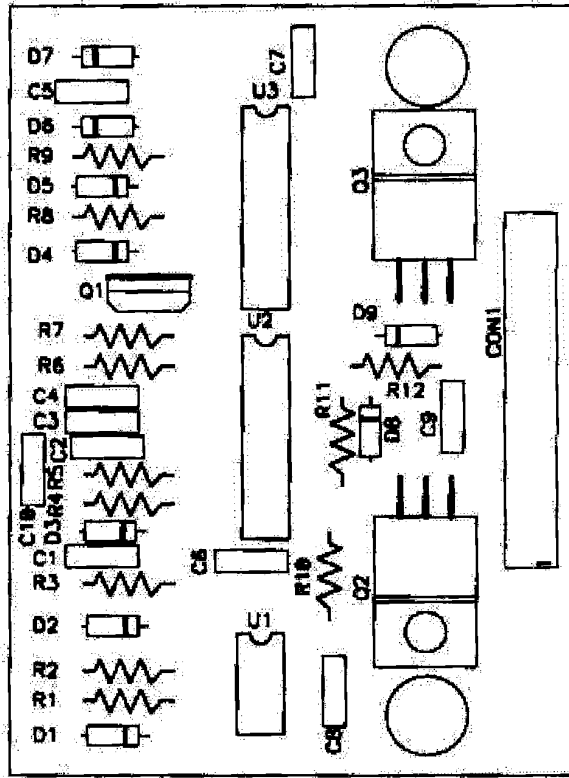

00362-1

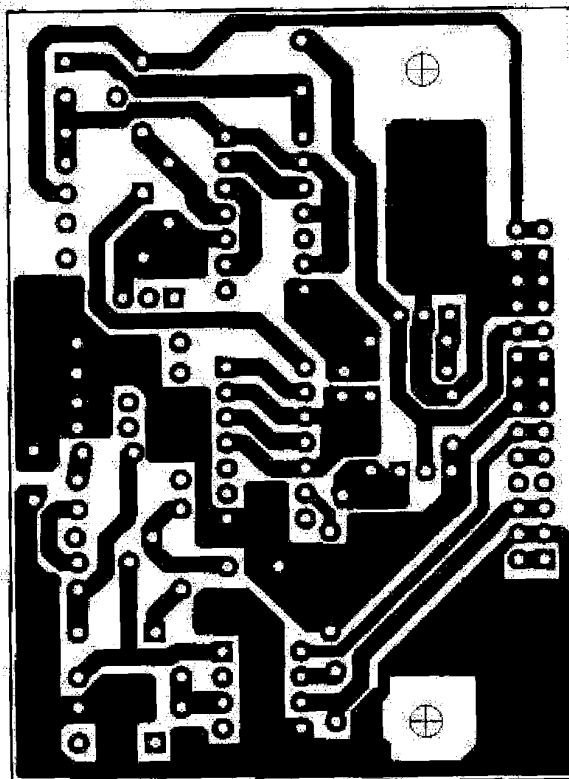

00362-2

00502-29

TOP SILK SCREEN

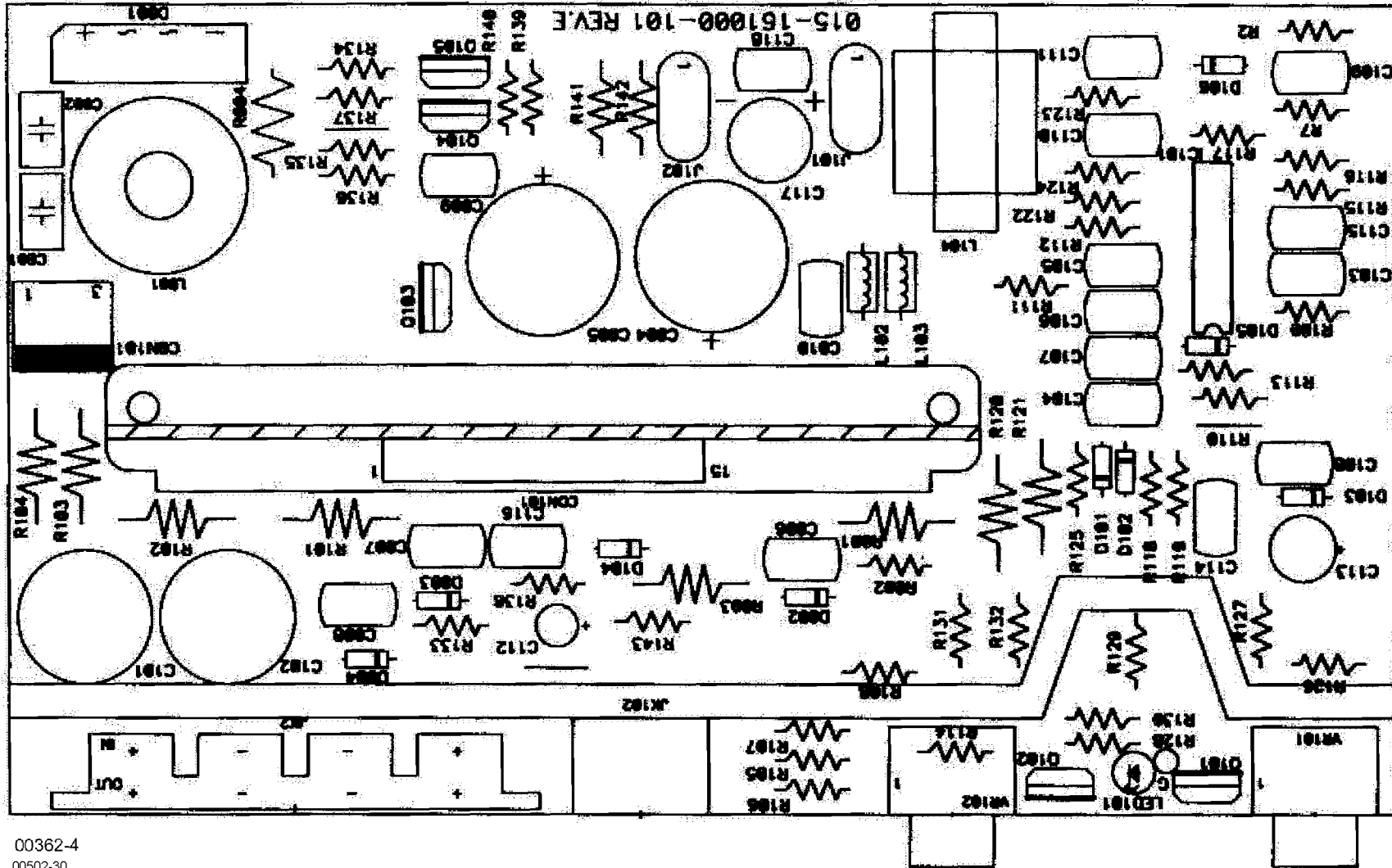

00362-4
00502-30

BU80E/HTS-10 REV C CIRCUIT BOARD (Cont.)

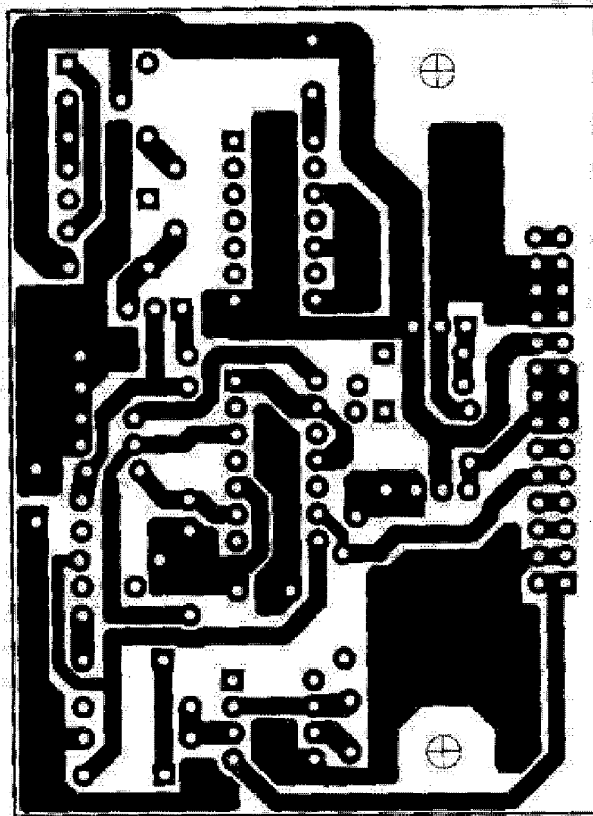
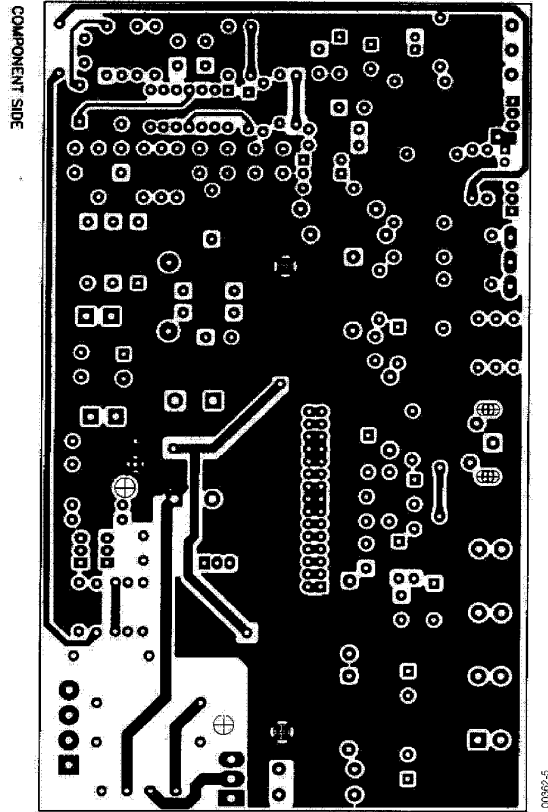

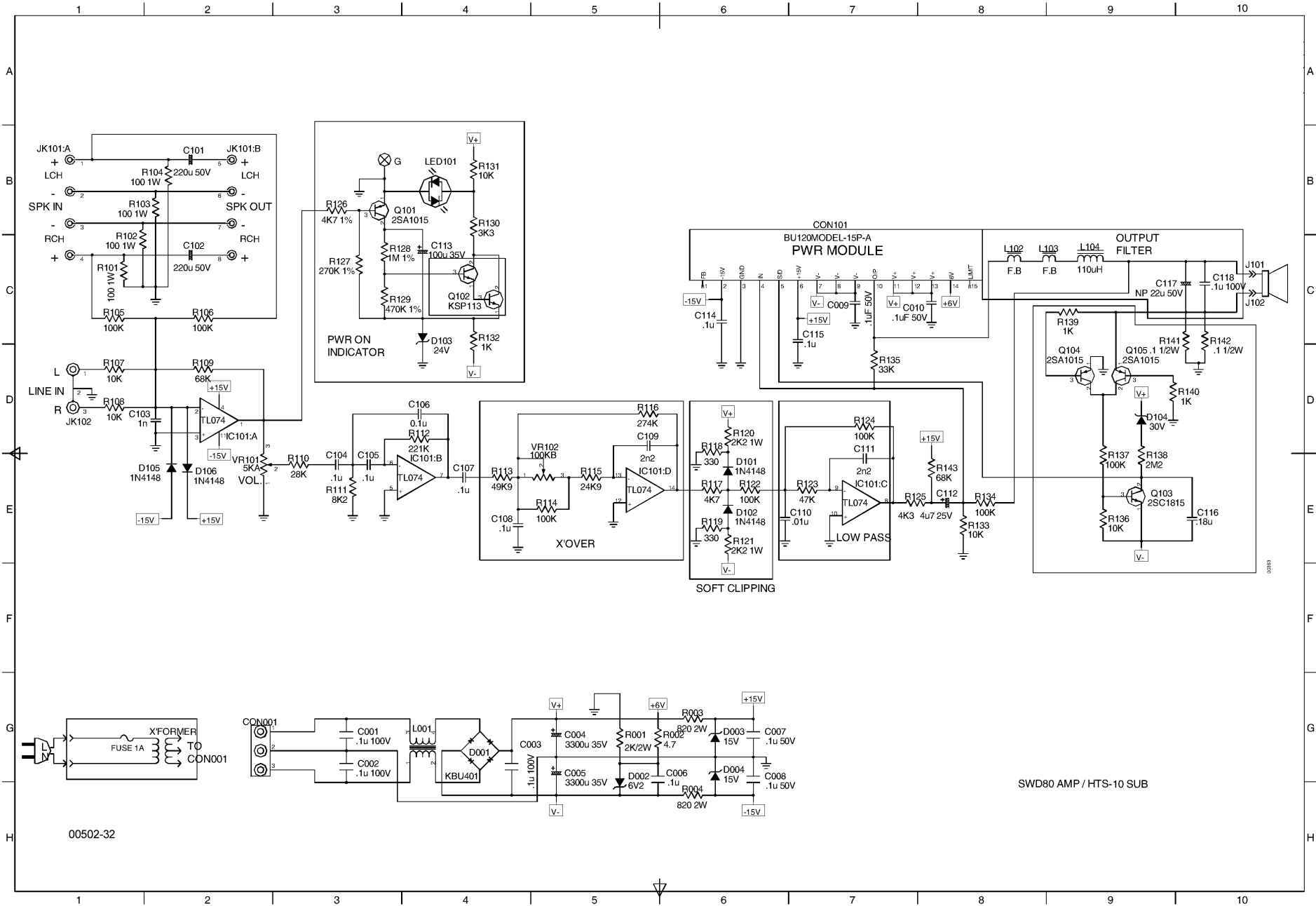

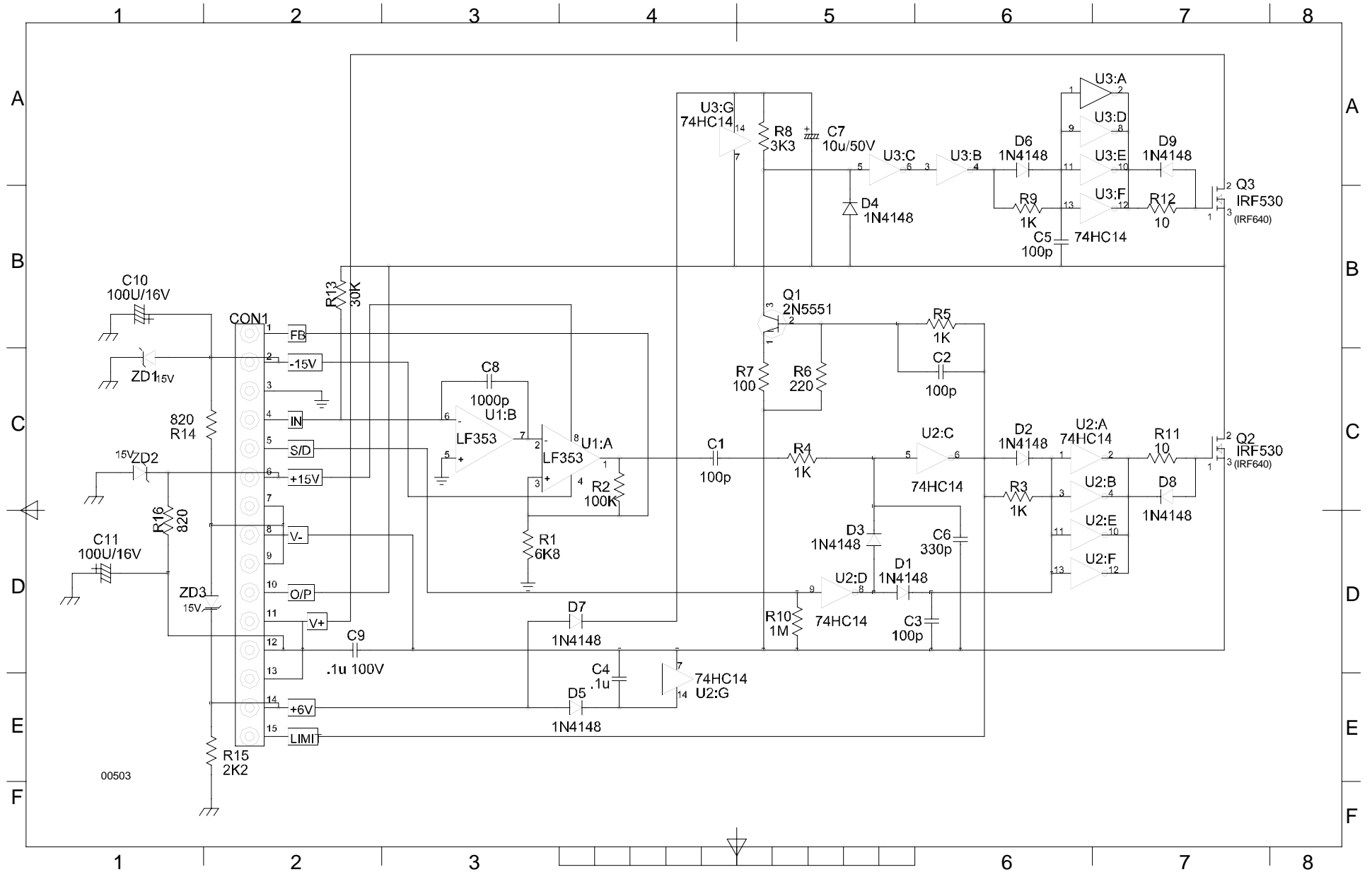

BU80E/HTS-10 rev C POWER AMP MODULE

