



**ENTRA**

**ENTRA POINT FIVE HTS**

**POWERED SUBWOOFER**

**SERVICE MANUAL**



Infinity Systems, Inc.  
250 Crossways Park Dr.  
Woodbury, New York 11797

Rev 2 12/2002

## TABLE OF CONTENTS

SPECIFICATIONS . . . . .	.3
DETAILED SPECIFICATIONS . . . . .	.4
CONTROLS and CONNECTIONS . . . . .	.5
OPERATION . . . . .	.7
MECHANICAL/PACKAGING PARTS LIST . . . . .	.8
EXPLODED VIEW . . . . .	.9
PACKAGING . . . . .	.10
TEST SETUP AND PROCEDURES . . . . .	.11
ELECTRICAL PARTS LIST . . . . .	.12
INTEGRATED CIRCUIT DIAGRAMS . . . . .	.17
BLOCK DIAGRAM . . . . .	.19
PCB DRAWINGS. . . . .	.20
SCHEMATICS . . . . .	.23

## Specifications

<b>Frequency Response:</b>	34Hz- 150Hz ( $\pm 3$ dB)
<b>Maximum Amplifier Power</b>	150 watts*, RMS, 500 watts peak, (20Hz - 150Hz with no more than 0.1% THD)
<b>Crossover Frequencies:</b>	50Hz - 150Hz, 24dB/octave, continuously variable
<b>Driver:</b>	10" (245mm) C.M.M.D. shielded DCR = 3.3 ohms $\pm 10\%$
<b>Dimensions (H x W x D):</b>	15" x 14-1/2" x 17" (381mm x 368mm x 432mm)
<b>Weight:</b>	47 lb (21.4kg) Each

Infinity continually strives to update and improve existing products, as well as create new ones. The specifications and construction details in this and related Infinity publications are therefore subject to change without notice.

## Detailed Specifications

### Entra Subwoofer 150W Powered Sub/ Plate Amp

LINE VOLTAGE	Yes/No	Hi/Lo Line	Nom.	Unit	Notes
US 120vac/60Hz	Yes	108-132	120	Vrms	Normal Operation
Parameter	Specification	Unit	Test Limits	Conditions	Notes
<b>Amp Section</b>					
Type (Class AB, D, other)	A/B	---			
Load Impedance (speaker)	4	Ohms		Nominal	Z-curve required
Rated Output Power	150	Watts		1 input driven, 50Hz	continuous for 3 sec.
THD @ 150W	1	%		22k filter, 50Hz	
THD @ 1 Watt	0.1	%		22k filter, 50Hz	
DC Offset	1	mV-DC		@ Speaker Outputs	
Damping factor	>100	DF			5-800Hz
<b>Input Sensitivity</b>					
Line Input	36	dBr		At max gain level, @50Hz	1 input driven
Speaker/Hi Level Input	10	dBr		At max gain level, @50Hz	1 input driven
<b>Signal to Noise</b>					
SNR-A-Weighted	100	dBA		relative to rated power	A-Weighting filter
SNR-unweighted	70	dBr		relative to rated power	22k filter
SNR rel. 1W-unweighted	60	dBr		relative to 1W Output	22k filter
Residual Noise Floor	1	mVrms		Volume @max, using RMS reading DMM/VOM (or A/P)	
Residual Noise Floor	1	mVrms(max)		Volume @max, w/ A/P Swept Bandpass Measurement (Line freq.+ harmonics)	
<b>Input Impedance</b>					
Line Input	10k	ohms		Nominal	
Speaker/Hi Level Input	1k	ohms		Nominal	
<b>Active Filters</b>					
<b>Low Pass (fixed or variable)</b>					
Frequency	150	Hz			
Slope	12	dB/Octave			
Q	1.4	Damping			
<b>Low Pass (fixed or variable)</b>					
Frequency	35-150	Hz			20k linear taper pot
Slope	12	dB/Octave			
Q	1	Damping			
<b>High Pass (fixed or variable)</b>					
Frequency	30	Hz			
Slope	12	dB/Octave			
Q	2	Damping			
<b>Switches</b>					
Main Power On/Off Switch	Rocker	--		"Auto": LED green; "Off": LED red	Locate at amp plate
Phase Switch	toggle				Locate at amp plate
<b>Limiters (yes/no)</b>					
yes	yes			Maximum Output Power	Maximum THD as a result of limiting.
<b>Output Volume Control</b>					
Volume Control Pot	yes	--			Locate at amp plate
Taper (lin/log)	A-taper	--			
<b>Input/Output Configuration</b>					
Line In	Normal	--		Single RCA phono jack, goes thru both fix and variable L.P.F., and H.P.F.	
Line In	Direct	--		Single RCA phono jack, bypasses variable L.P.F, goes thru fixed H.P.F. and L.P.F.	
Spkr / Hi Level In (L,R)	L,R	--		Spring-loaded terminal	
Spkr / Hi Level Out (L,R)	L,R	--		Spring-loaded terminal	Directly connect to Hi Level In, internally
<b>Signal Sensing (ATO)</b>					
Auto-Turn-On (yes/no)	yes	--			
ATO Level	5	mV		Line Input w/ 1 ch. driven	
Auto Mute/ Turn-OFF Time	15	minutes			Time before muting, after signal is removed
<b>Power on Features</b>					
Power on Delay time	>2	sec.		AC Power Applied	
Power on LED	yes	--		Bi-color LED located on amp plate	
<b>Transients/Pops</b>					
ATO Transient	5	mV-peak		@ Speaker Outputs	
Turn-on Transient	30	mV-peak		@ Speaker Outputs	AC Line cycled from OFF to ON
Turn-off Transient	30	mV-peak		@ Speaker Outputs	AC Line cycled from ON to OFF
<b>Efficiency</b>					
Stand-by Input Power	10	Watts		@ nom. line voltage	
AC Power Cons. @1W	26	Watts		@ nom. line voltage	
Power Cons. @rated power	250	Watts		@ nom. line voltage	
Efficiency	50	%			
<b>Protection</b>					
Short Circuit Protection		--		Direct short at output	
Thermal Protection	yes	--		@ 1/8 max unclipped Power	
DC Offset Protection	yes	--		DC present at Speaker Out leads	Relay or crowbar (for driver/fire protection)
Line Fuse Rating	3	Amps		Type-T or Slo Blo	Internal fuse behind amp plate

# Controls and Connections

## CONTROLS AND CONNECTIONS

Rear Panel

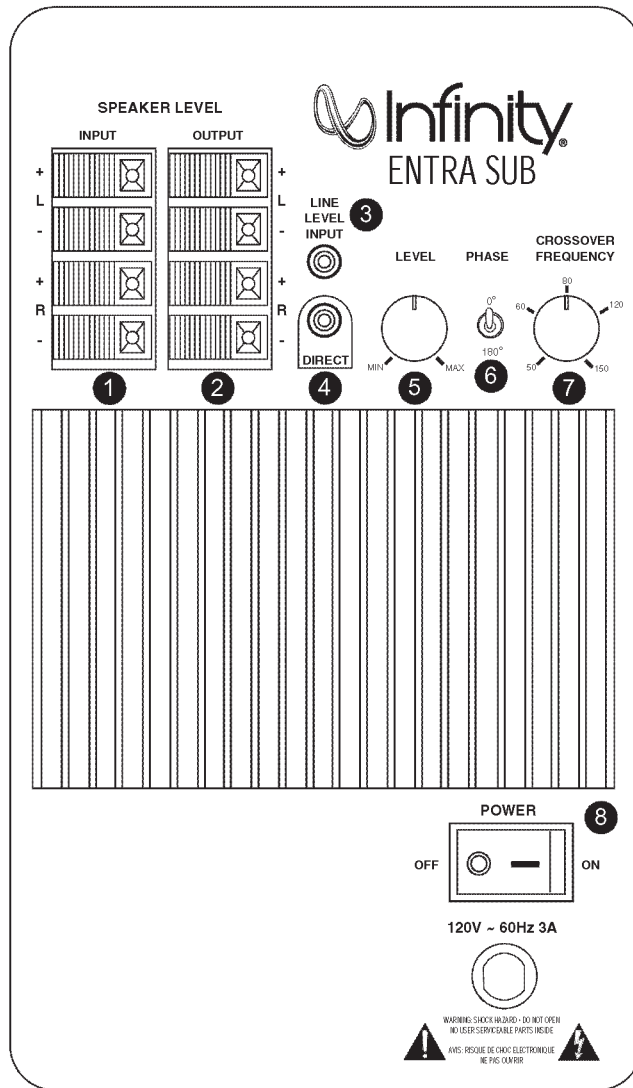

- 1 Speaker-Level Inputs
- 2 Speaker-Level Outputs
- 3 Line-Level Input
- 4 Direct (LFE) Input
- 5 Subwoofer-Level Control
- 6 Phase Switch
- 7 Low-Pass Frequency Adjustment
- 8 Power Switch

00305-1

## Controls and Connections (Cont.)

### SYSTEM CONNECTIONS

If your receiver/processor does not have subwoofer outputs for the left and right channels or an LFE output:

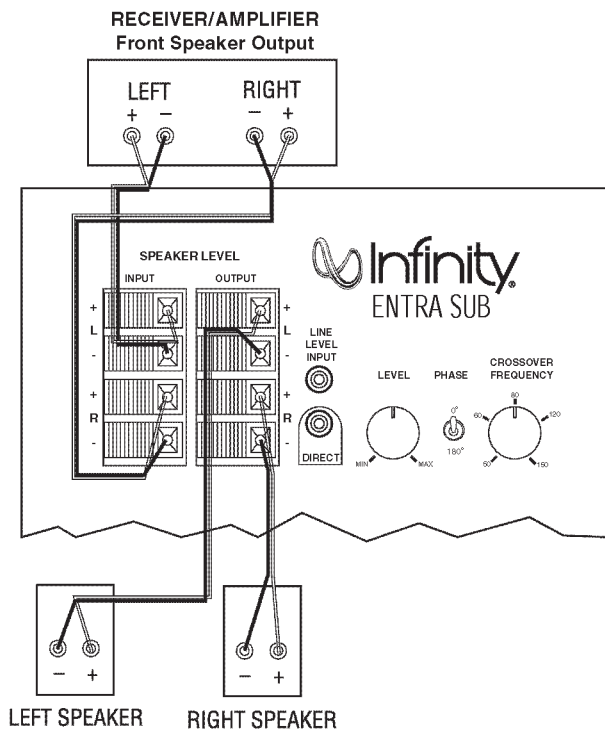

If you have a Dolby\* Digital or DTS® receiver/processor with a low-frequency-effect (LFE) or subwoofer output:

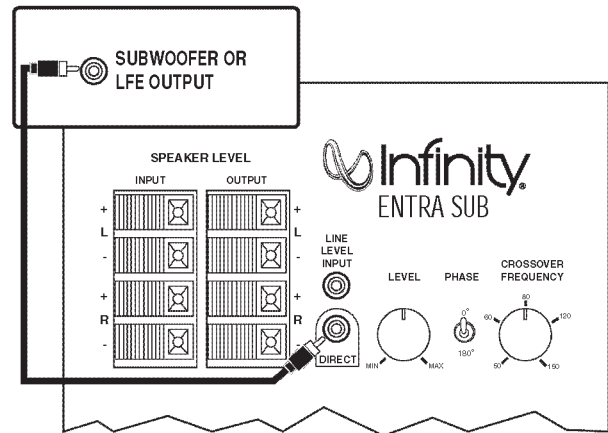

If your receiver/processor does not contain a Dolby Digital or DTS processor but has a subwoofer output:

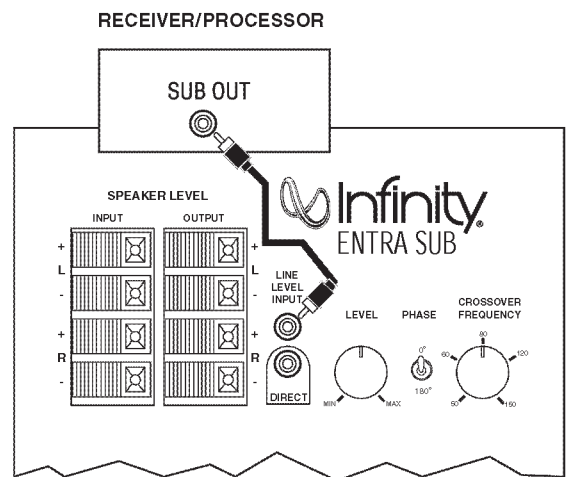

NOTE: Some receivers have two subwoofer outputs. In that case, it is recommended that you use a Y connector (not included) to maximize performance.

## Operation

### OPERATION

#### Power On

Plug your subwoofer's AC cord into a wall outlet. Do not use the outlets on the back of the receiver.

Initially set the subwoofer's Level control **5** to the "0" position.

Turn on your sub by pressing the Power button **8** on the rear panel.

Turn on your entire audio system and start a CD or movie soundtrack at a moderate level.

#### Adjust Gain

Turn your subwoofer's Level control **5** up to the "5" position (half way). If no sound emanates from the subwoofer, check the AC-line cord and input cables. Are the connectors on the cables making proper contact? Is the AC plug connected to a "live" receptacle? Has the Power button **8** been pressed to the "On" position? Once you have confirmed that the subwoofer is active, proceed by playing a CD, record or cassette. Use a selection that has ample bass information.

Set the overall volume control of the preamplifier or stereo to a comfortable level. Adjust the subwoofer's Level control **5** until you obtain a pleasing blend of bass. Bass response should not overpower the room but rather be adjusted so there is a harmonious blend across the entire musical range. Many users have a tendency to set the subwoofer volume too loud, adhering to the belief that a subwoofer is there to produce lots of bass. This is not entirely true. A subwoofer is there to enhance bass, extending the response of the entire system so the bass can be felt as well as heard. However, overall balance must be maintained or the music will not sound natural. An experienced listener will set the volume of the subwoofer so its impact on bass response is always there but never obtrusive.

#### Crossover Adjustments

Low-Pass Frequency Adjustment control **7** – The Low-Pass control determines the highest frequency at which the subwoofer reproduces sounds. If your main speakers can comfortably reproduce some low-frequency sounds, set this control to a lower frequency setting, between 50Hz – 100Hz. This will concentrate the subwoofer's efforts on the ultradeep bass sounds required by today's films and music. If you are using smaller bookshelf speakers that do not extend to the lower bass frequencies, set the Low-Pass Frequency Adjustment control to a higher setting, between 120Hz – 150Hz.

Note: This control will have no effect if the Direct Input is used. If you have a Dolby Digital or DTS processor/receiver, the Low-Pass Frequency is set by the processor/receiver. Consult your owner's manual to learn how to view or change this setting.

#### Phase Control

The Phase switch **6** determines whether the subwoofer speaker's piston-like action moves in and out with the main speakers, 0°, or opposite the main speakers, 180°. Proper phase adjustment depends on several variables such as room size, subwoofer placement and listener position. Adjust the phase switch to maximize bass output at the listening position.

00305-5

**Mechanical/Packaging Parts List****MECHANICAL PARTS LIST**

1	SCREW, (16), #8 x .75, BLK, PB TRPH	336806-001
	AMPLIFIER	NOT FOR SALE
2	WOOFER, 10" (254mm)C.M.M.D. SHIELDED DCR = 3.3 ohms $\pm$ 10%	336649-001
3	GRILLE CUP (6)	333249-001
4	SCREW, (6), #6 x .75, BLK, PB PPH	903401-012
5	GRILLE	336454-001
6	FRONT BAFFLE	336452-001
7	FOOT (4)	330163-001
8	PORT TUBE	336806-001

**PACKAGING**

9	OWNERS MANUAL	336422-002
10	WARRANTY CARD	335841-001
11	SURVEY CARD	335868-002
12	PAD, TOP, END (2)	336457-001
13	CARTON	336458-001



## Exploded View

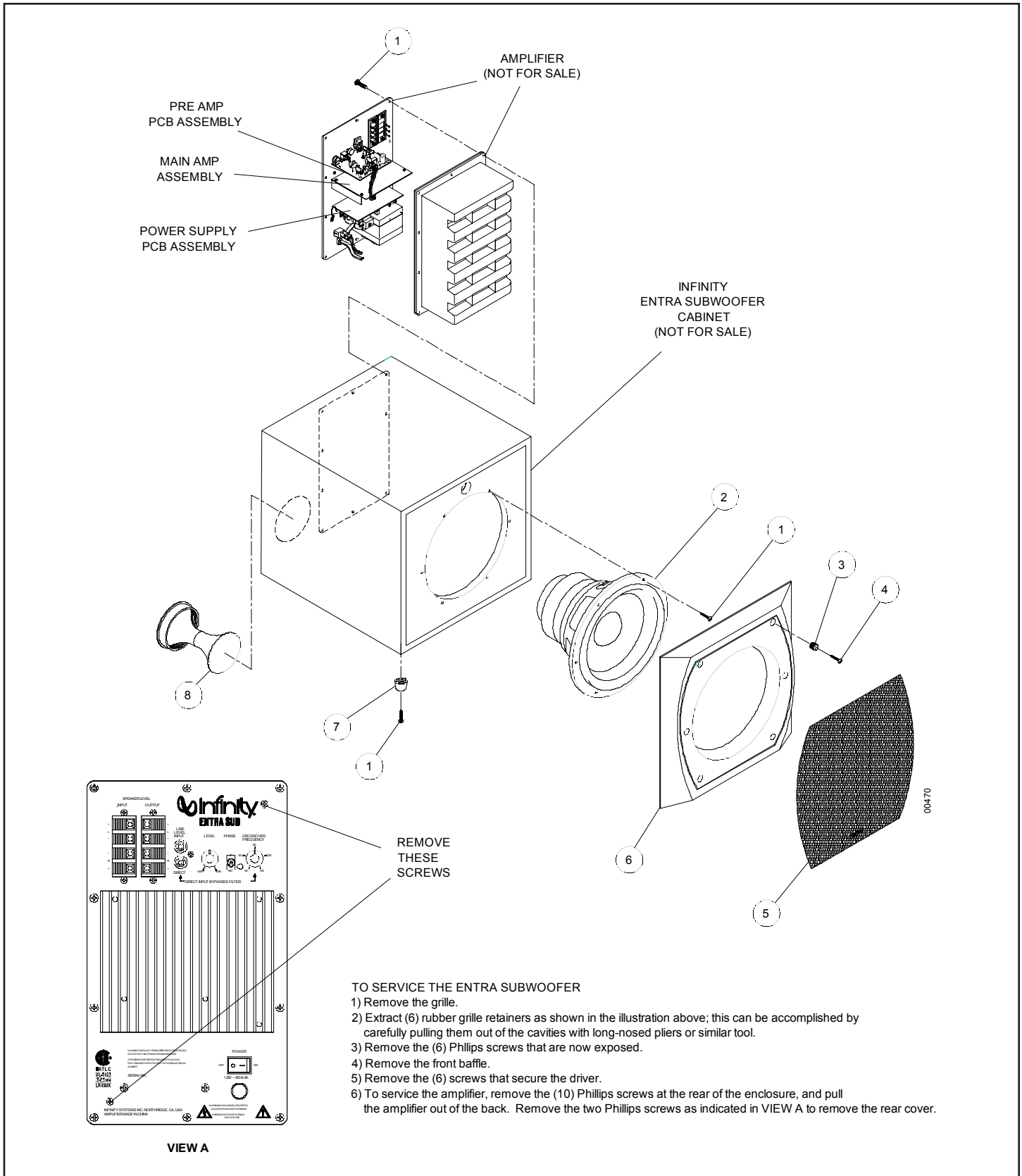

# Packaging

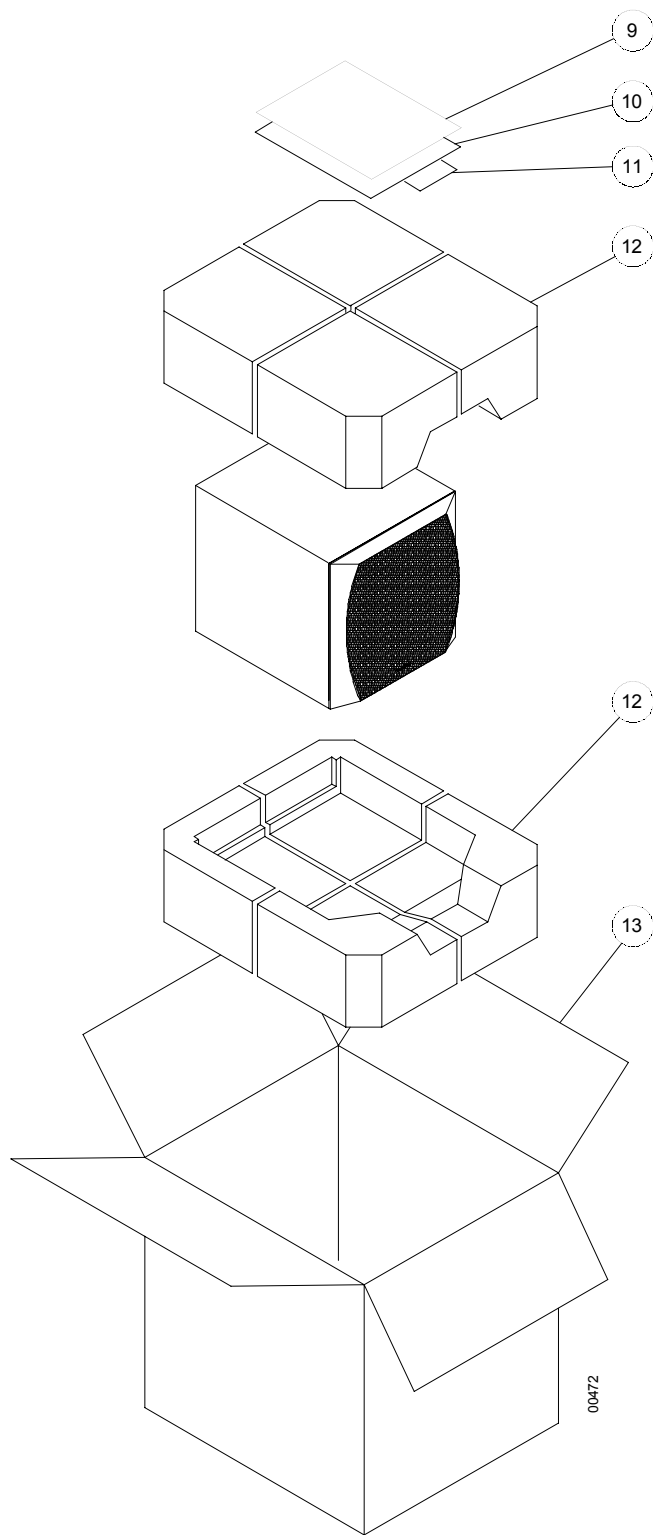

## Test Setup and Procedure

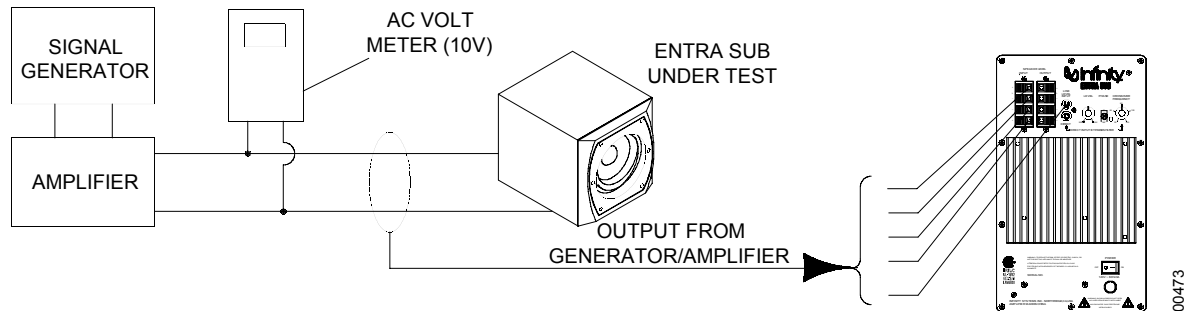

### SYSTEM AURAL SWEEP TEST

#### Equipment needed:

- Function/signal generator/sweep generator
- Integrated Amplifier
- Multimeter
- Speaker cables

#### General Unit Function (UUT = Unit Under Test)

Switches/knobs on the amplifier faceplate:

Crossover Frequency adjust full CW (150Hz)

Phase switch – either position

1. From the signal generator, Connect single line level input (RCA) cable to “Line Level Input” jack on UUT.
2. Turn the LEVEL control full counterclockwise (Min).
3. Turn on generator, adjust to **400mV, 30 Hz**.
4. Plug in UUT; turn the power switch ON. Turn LEVEL control full clockwise (Max)
5. LED should now be Green; immediate bass response should be heard and felt from rear port tube opening.
6. Turn off generator, turn LEVEL control fully counterclockwise (Min), disconnect RCA cable.
7. Connect two pairs of speaker cables to Speaker Level input terminal on UUT. Cables should be connected to an integrated amplifier fed by the signal generator. Observe polarity.
8. Turn on generator and adjust so that speaker level input at the amplifier is **6.0V, 30 Hz**. Turn LEVEL control full clockwise (Max)
9. Green LED should light, immediate bass response should be heard and felt from the port tube opening.

#### Sweep Function

1. Follow steps 7-10 above, using a sweep generator as a signal source.
2. Sweep generator from 20Hz to 20kHz. Listen to the cabinet and drivers for any rattles, clicks, buzzes or any other noises. If any unusual noises are heard, remove woofer and test.

#### Driver Function (Woofer)

1. Remove woofer from cabinet; detach + and - wire clips. See page 9 for removal instructions.
2. Check DC resistance of woofer; it should be **3.3 ohms±10%**.
3. Connect a pair of speaker cables to driver terminals. Cables should be connected to an integrated amplifier fed by a signal generator. Turn on generator and adjust so that speaker level output is **5.0V**.
4. Sweep generator from 20Hz to 1kHz. Listen to driver for any rubbing, buzzing, or other unusual noises.

## Electrical Parts List

Part No.	Description	Designator	Quantity
<b>PRE AMP PCB ASSEMBLY</b>			
Resistors			
020-100498-120	CARBON FILM RESISTOR 1K 1/8W J	R107,123,138	3
020-100598-120	CARBON FILM RESISTOR 10K 1/8W J	R136,127,121, 135,124,125	6
020-100698-120	CARBON FILM RESISTOR 100K 1/8W J	R133	1
020-110598-120	CARBON FILM RESISTOR 11K 1/8W J	R122	1
020-150598-120	CARBON FILM RESISTOR 15K 1/8W J	R118	1
020-180698-120	CARBON FILM RESISTOR 180K 1/8W J	R128	1
020-220698-120	CARBON FILM RESISTOR 220K 1/8W J	R126,129	2
020-330498-120	CARBON FILM RESISTOR 3K3 1/8W J	R132,134	2
020-750498-120	CARBON FILM RESISTOR 7K5 1/8W J	R110,112	2
021-100401-120	M.O.F. RESISTOR 1K 1W J MO-100	R101,102	2
021-100598-100	METAL FILM RESISTOR 10K 1/8W F	R109	1
021-154598-100	METAL FILM RESISTOR 15K4 1/8W F (MF)	R137	1
021-169598-100	METAL FILM RESISTOR 16K9 1/8W F (MF)	R120	1
021-200698-100	METAL FILM RESISTOR 200K 1/8W F	R103,104,105,106	4
021-215598-100	METAL FILM RESISTOR 21K5 1/8W F (MF)	R111	1
021-280498-100	METAL FILM RESISTOR 2K8 1/8W F	R130	1
021-442598-100	METAL FILM RESISTOR 44K2 1/8W F	R131	1
021-511498-100	METAL FILM RESISTOR 5K11 1/8W F	R116,117	2
Capacitors			
030-100247-300	CERAMIC CAPACITOR 0u1/50V Z P:5	C110,109,121,122, 118,119	6
030-220223-300	CERAMIC CAPACITOR 220P/50V K P:5	C105,106,107	3
032-100243-301	PE CAPACITOR 0u1/63V J P:5m/m	C114	1
032-220353-300	PE CAPACITOR 0u22/63V J P:5m/m	C104,108	2
032-470353-303	PE CAPACITOR 0u47/63V J P:5m/m	C113,125,123	3
034-100525-300	ELEC. CAPACITOR 10uF/25V M (R) P:5	C102,103,120	3
034-100614-300	ELEC. CAPACITOR 100uF/16V M (R)2.5	C127,128	2
034-100715-200	ELEC. CAPACITOR PC 1000uF/16V M (R)P:5	C124	1
034-220515-300	ELEC. CAPACITOR PC 22uF/16V M (R) P:5	C111	1
Semiconductors			
050-414802-100	DIODE 1N4148	D101,102,103, 104,109	5
050-505200-000	LED P/N:UDC-5052W LED	D110	1
051-101501-000	TRANSISTOR PNP 2SA1015GR TO-92	Q102,103	2
051-181502-000	TRANSISTOR NPN 2SC1815GR TO-92	Q101	1
053-007200-000	IC TL072 CP DIP DUAL OP-AMP	IC102	1
053-007400-000	IC TL074CN QUAD OP-AMP	IC101	1
053-455801-000	I.C PC BA4558 (ROHM) DUAL OP-AMP	IC103	1

## Electrical Parts List

Part No.	Description	Designator	Quantity
Miscellaneous			
072-010058-000	RCA JACK 2P P/N:052000W1G(Red,White)	JK101	1
074-030002-000	TOGGLE SW P/N L101	SW101	1
083-031605-000	CONNECTOR LEAD WIRE #26 L:60mm #18 L:70mm	CN1	1
083-052618-000	CONNECTOR LEAD WIRE EH2.5-7P+SCN2.5P+7 LEAD WIRE	CN101	1
026-200595-263	VR P/N:R1210G-2A1-B20Kx2 10%	VR101	1
026-200595-264	VR P/N:R1210N-2A1-B20K 10%	VR102	1

### MAIN AMP ASSEMBLY

Resistors			
020-100398-120	CARBON RESISTOR 100R 1/8W J	R511,714,719	3
020-100498-120	CARBON RESISTOR 1K 1/8W J	R506,721,507,702	4
020-100598-120	CARBON RESISTOR 10K 1/8W J	R503,610,504,510, 512,601,606	7
020-100698-120	CARBON RESISTOR 100K 1/8W J	R712,725,731	3
020-150498-120	CARBON RESISTOR 1K5 1/8W J	R713,718,721	3
020-150598-120	CARBON RESISTOR 15K 1/8W J	R607,709,711	3
020-220498-120	CARBON RESISTOR 2K2 1/8W J	R710,742	2
020-220598-120	CARBON RESISTOR 22K 1/8W J	R502,508,701,703	4
020-220698-120	CARBON RESISTOR 220K 1/8W J	R603	1
020-270398-120	CARBON RESISTOR 270R 1/8W J	R715,717	2
020-270698-120	CARBON RESISTOR 270K 1/8W J	R611	1
020-330297-120	CARBON RESISTOR 33R 1/4W J	R723,724	2
020-390598-120	CARBON RESISTOR 6 39K 1/8W J	R716	1
020-470498-120	CARBON RESISTOR 4K7 1/8W J	R602	1
021-470597-120	M.O.F. RESISTOR 47K 1/4W J	R728	1
020-470598-120	CARBON RESISTOR 47K 1/8W J	R505,604,605	3
020-560398-120	CARBON RESISTOR 560R 1/8W J	R743	1
021-100003-020	M. O. F. RESISTOR 0R1 3WS J	R734,735	2
021-100201-121	M. O. F. RESISTOR 10R 1W J MO	R608,609	2
021-100397-120	M. O. F. RESISTOR 100R 1/4W J	R726,730	2
021-100401-120	M. O. F. RESISTOR 1K 1W J	R739	1
021-100496-120	M. O. F. RESISTOR 1K 1/2W	R727,729	2
021-330498-120	M. O. F. RESISTOR 3K3 1/8W J	R720	1
021-499698-100	METAL FILM RESISTOR 499K 1/8W F	R513,509	2
021-680296-120	M. O. F. RESISTOR 68R 1/2W J	R732,733	2
Capacitors			
030-100264-300	CERAMIC CAPACITOR 0u1/100V K NPO	C718,707,708,719	4
030-220223-300	CERAMIC CAPACITOR 220P/50V K P:5	C703,702,717,716	4
030-220244-261	CERAMIC CAPACITOR 22pF/50V J NPO	C712,713	2
030-470344-200	CERAMIC CAPACITOR PC 470pF/50V 10	C715,714,711,710	4

## Electrical Parts List (Cont.)

Part No.	Description	Designator	Quantity
032-100393-300	PE CAPACITOR 0u1/63V J P:5	C606,607,601,709	4
034-100515-301	ELEC. CAPACITOR PC 10uF/16V M (R)0511	C701,723	2
034-100615-301	ELEC. CAPACITOR 100uF/16V M (R)0611	C605	1
034-100695-300	ELEC. CAPACITOR 100uF/63V M (R)1012	C720,721	2
034-470415-300	ELEC. CAPACITOR 4u7/50V M (R)0511 P:	C501,603	2
034-470515-000	ELEC. CAPACITOR 47uF/16V M (R)0511	C502,604,704	3
035-220143-100	PE CAPACITOR FE-M 0u0022/63V J P:5m/m	C608	1
035-220243-100	PE CAPACITOR FE-M 0u022/63V J P:5m/m	C503	1
Semiconductors			
050-003000-100	ZENER DIODE 30V HZ-30-2 05000881	D807	1
050-400201-100	DIODE 1N4002 100V/1A TAPING	D710,711,601, 717, 712, 806	6
050-414802-100	DIODE 1N4148	D501,713,715,716, 714,708,709	7
053-123700-100	IC PC UPC 1237HA LIMITER	IC601	1
053-455801-000	I.C PC BA4558 (ROHM) OP-AMP	IC501,701	2
051-003100-000	TRANSISTOR TIP 31C TO-220	Q707	1
051-003200-000	TRANSISTOR TIP 32C TO-220	Q708	1
051-046900-000	TRANSISTOR 4 BF469	Q704	1
051-047000-000	TRANSISTOR BF470	Q703	1
051-066900-000	TRANSISTOR 1 2SD669A (C class)	Q711	1
051-138600-000	TRANSISTOR 2SA 1386(SANKEN) TO-3P	Q710	1
051-181500-000	TRANSISTOR PC 2SC1815GR	Q501,502,602,603	4
051-351900-000	TRANSISTOR 2SC 3519(SANKEN) TO-3P	Q709	1
051-540100-000	TRANSISTOR 2N5401	Q702,706,601	3
051-555100-000	TRANSISTOR 2N5551 TO-92	Q701,705	2
Miscellaneous			
061-700011-101	SLICON RUBBER PCS P/N:1877 110x30mm t=0.19mm		1
072-040007-000	7P WAFER SWA101 BC501 JS-1001-07		1
072-040039-000	TERMINAL (PCB) PC205 (t=0.8m/m)T205MA	J602	1
072-040041-000	TERMINAL(PCB) T250MA (P/N 0635R-BL2)	J601	1
072-040206-000	CONNECTOR P/N:3PIN JS-1001-4 P:2.5	CON802	1
073-014005-600	BRACKET(LEFT SIDE) PCS 72x19m/m t=1mm		1
073-014006-600	BRACKET(RIGHT SIDE) PCS 72x19m/m t=1mm		1
074-300004-000	RELAY 48VDC P/N PCE-148D1H	RLY601	1
083-022547-000	CONNECTOR WIRE #18 VH3.96+SCN2.5	CN302	1
025-050001-000	VARISTOR TSA-104	TH601	1

**Electrical Parts List (Cont.)**

<b>Part No.</b>	<b>Description</b>	<b>Designator</b>	<b>Quantity</b>
<b>POWER SUPPLY PCB ASS'Y</b>			
Resistors			
020-820497-120	CARBON RESISTOR 8K2 1/4W J	R301,304	2
021-470301-120	MO RESISTOR 470R 1W J MB TYPE MO-100	R303,302	2
Capacitors			
030-100264-300	CERAMIC CAPACITOR 0u1/100V K NPO TAPING	C2,3	2
030-100295-201	UL SAFETY CAPACITOR YS-SC103Z2 10000pF/400V	C309	1
034-220515-300	ELEC. CAPACITOR PC,308 22uF/16V M (R)0511	C307	1
034-220615-301	ELEC.CAPACITOR 220uF/16V M (R)0611 P:5	C305,306	2
034-470763-301	ELEC.CAPACITOR 4700uF/63V M (R) 25*40	C303,304	2
Semiconductors			
050-001500-000	DIODE 15V 1/2W HZ15-3	ZD301,302	2
051-118900-100	TRANSISTOR 2SD882P(TO-220)	Q301	1
051-677000-000	TRANSISTOR 2SB772 (TO-220)	Q302	1
Miscellaneous			
052-602000-000	RECTIFY DIODE KBU8D(SUB-100W) 8A/200V	BD2	1
072-040032-000	WAFER 2 P:3.96 3P MALE VH	CN30	1
073-032027-000	HEAT SINK PCS 40x24x2.0m/m		1
083-021805-000	LEAD WIRE #22 GND WIRE L:80mm 5TT+5TT		1
083-022548-000	LEAD WIRE #18 UL1015 PCS T187(t0.8)+ B1811T0P-2		2
083-031603-000	4Px120mm CONNECTOR 1 LEAD WIRE #22 +5TT	CN30	1
091-000130-000	FUSE HOLDER PCS P/N:CQ-203SP		2
093-105203-300	FUSE:UL GSL(2AG) FUSE:3A,250V,5*20mm	F301	1
<b>MISCELLANEOUS</b>			
005-009885-000	GASKET 97.5x85x36cm		1
005-033420-000	STYROFOAM 335.0x191.0x65.0mm		40
008-068701-000	GASKET SM-55 GASKET 860.0x5.0 t=2.0mm		2
042-010042-000	TRANSFORMER P/N:PT-1739		1
061-020000-000	KNOB ABS HTS-10/20 p20x15m/m UL94V-0 BLK		2
061-314002-000	CORD BUSHING P/N SB4F-2		1
061-800000-000	TRANSISTOR COVER P/N:TW-1		2
062-050400-000	PUSH TERMINAL 4P JK102A,JK102B P/N E405		2
062-261313-000	BUCKET(HI PS 94VO)304.8x177.8x124.2m/m BLK		1
063-062512-000	PLATE 304.8x177.8 t=2.5mm (SPCC)		1
066-120300-900	CABLE TIE PCCV-120S		3
070-000030-410	SCREW TRANSFORMERx4,HEAT SINKx6 M4;4x10m/m BLK		10
070-040010-210	SCREW PC TRAN.x5,TH601x1,GROND WIREx1 PMS M3x10m/m BLK		7
070-400010-206	SCREW PCB VS BRACKETx4,BRACKET VS HEAT SINKx23x6m/m BLK		6
070-400010-212	SCREW 3x12m/m BLK		1
070-400010-812	SCREW RCA JACKx1 PTS-4 3x12 BLK		1

**Electrical Parts List (Cont.)**

<b>Part No.</b>	<b>Description</b>	<b>Designator</b>	<b>Quantity</b>
071-060031-400	NUT WITH GEAR TRANS FOR MERx2 K-NUT 4p		2
071-100810-100	FLAT WASHER PC TRANS FOR MERx4 ID=4.3 OD=9.5 t=0.8m/m		4
071-140031-901	GEAR WASHER BACK PANEL VS GROUND WIRE M3 BLK		1
072-050002-000	GROUND WASHER GROUND WIRE VS PANEL GND-1		1
073-032306-600	HEAT SINK ALUM. 154x125x34mm		1
074-020015-000	ROCKER SW 125V/5A P/N:R19-33A(SPST)PIN LOCK TYPE		1
083-041600-004	AC CORD SPT-2 #16 12 FEET+5TT DOUBLE INSULATE		1



# Integrated Circuit Diagrams

OPAMP, QUAD 14P DIL TI074  
IC101

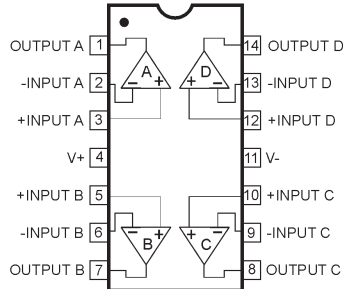

OPAMP, DUAL 8PIN DIL TL072/BA4558/BA5532  
IC102, IC103, IC501, 701

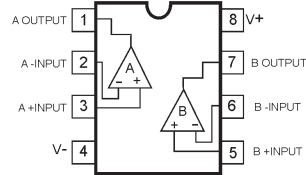

TRANS 2SA1386, 2SC3519  
Q710, Q709

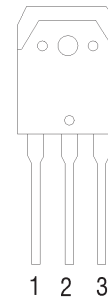

TRANS, NPN, 2SA1015,  
TIP31F/32F, 2SD882P  
Q102, 103, 710, 707, 708, 301

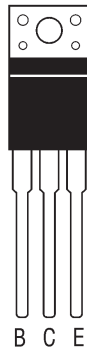

TRANS, PNP 2SB772,  
Q302



TRANS BF469/70,  
Q704, Q703

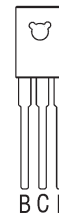

TRANS, PNP 150V 0.6A  
2N5401,  
Q102, 103

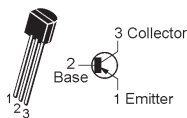

TRANS, NPN 150V 0.6A  
2SC1815  
Q101, 501, 502, 602, 603

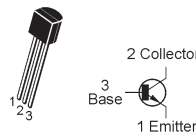

TRANS, PNP 150V 0.6A  
2SC1815GR,  
702, 706, 601

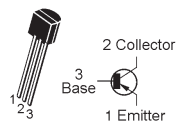

TRANS, NPN 150V 0.6A  
2N5551,  
701, 705

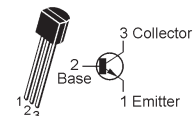

00328-2

## Integrated Circuit Diagrams (Cont.)

μPC1237HA IC601

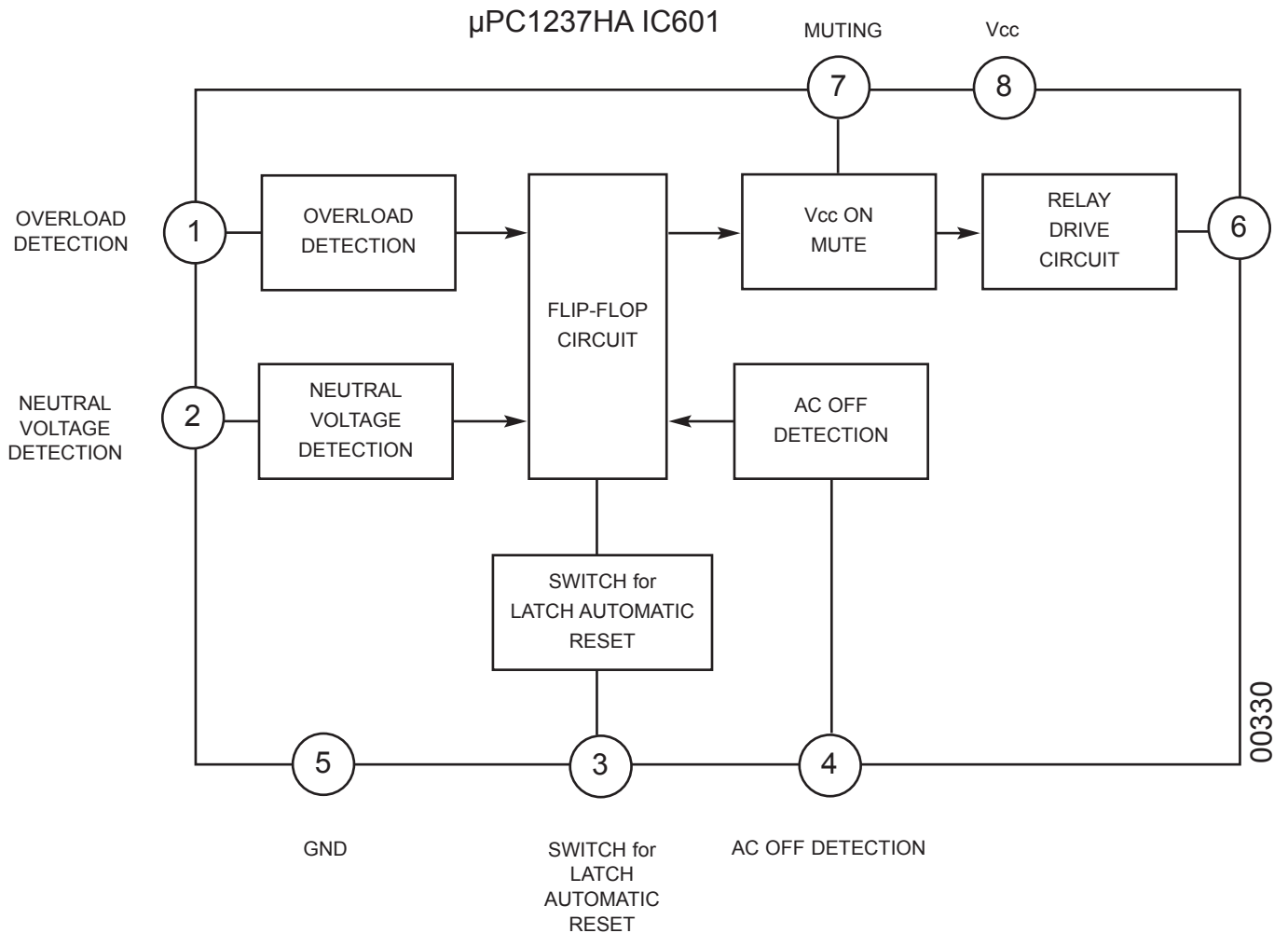
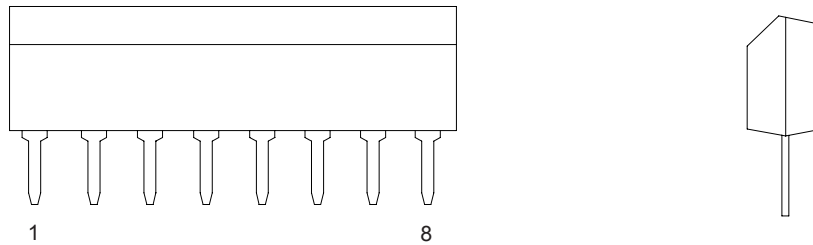

## Block Diagram

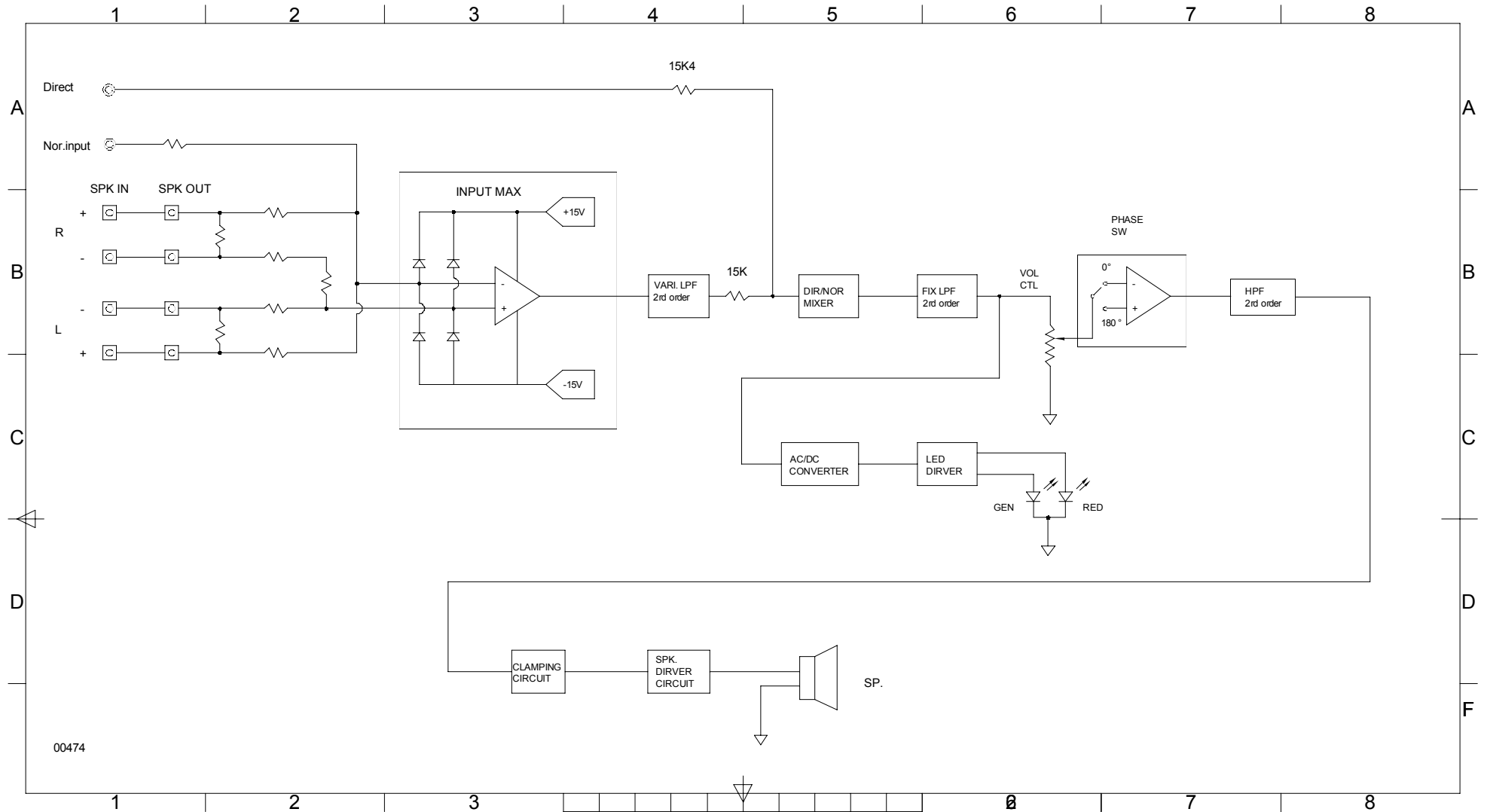

# Entra Subwoofer



TOP SILK SCREEN

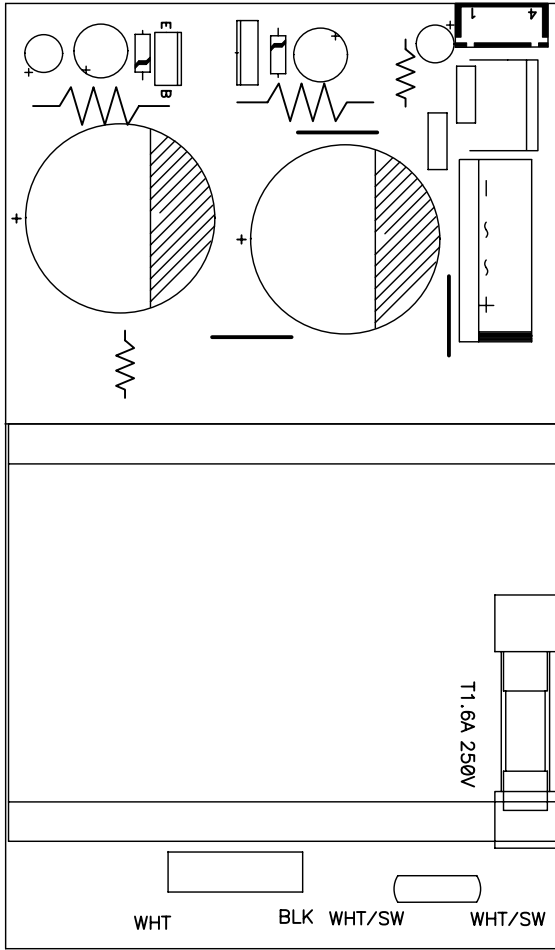

SOLDER SIDE

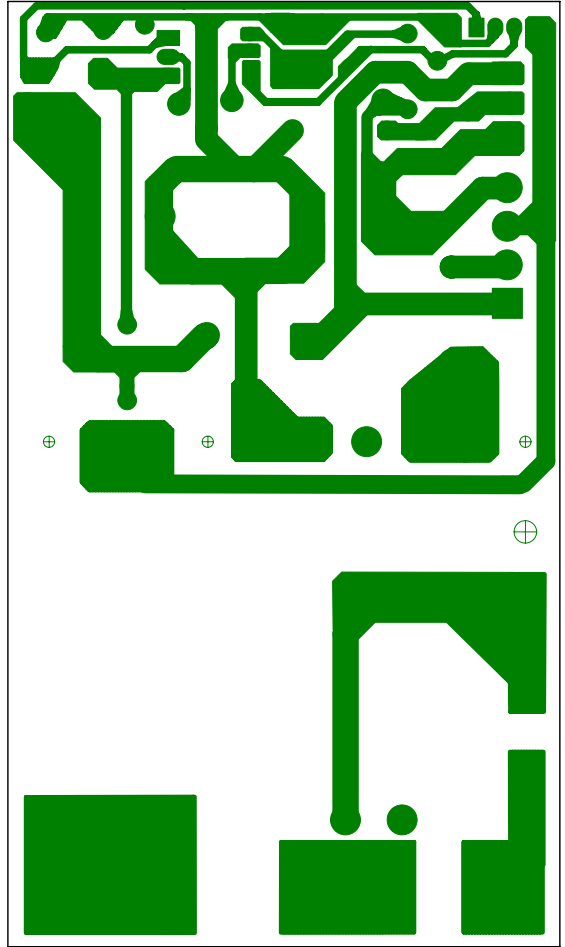

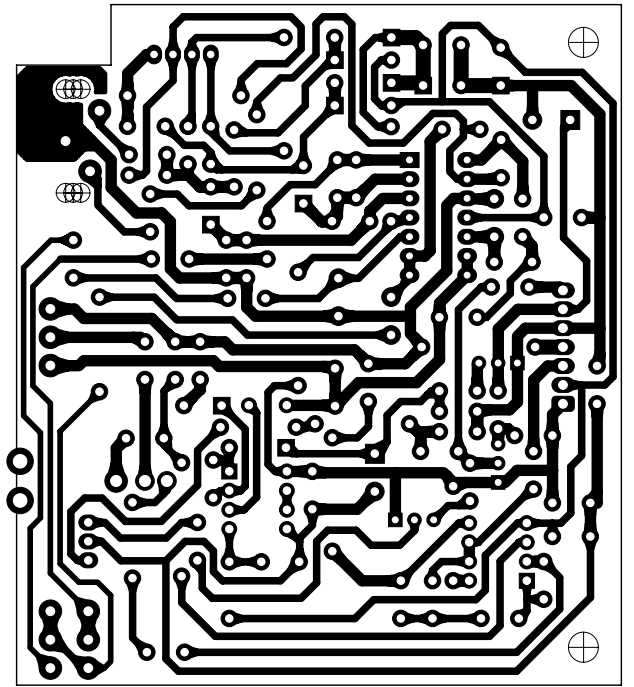

SOLDER SIDE

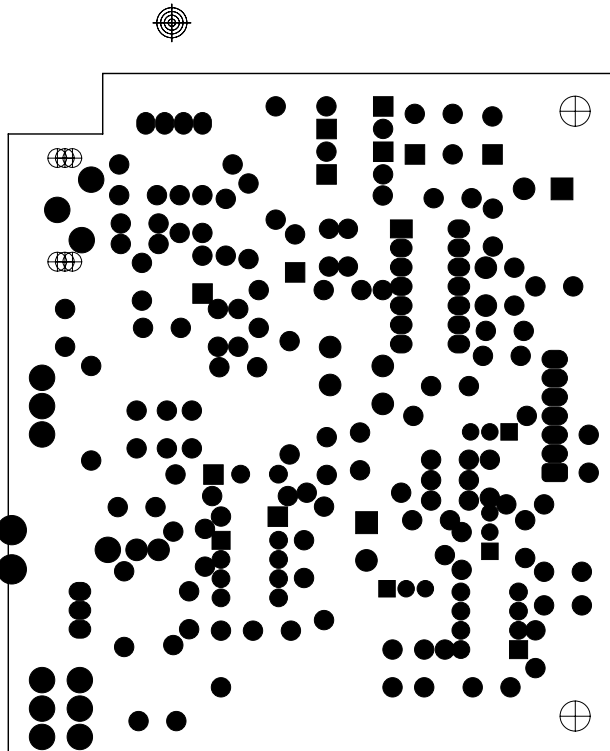

SOLDER MASK

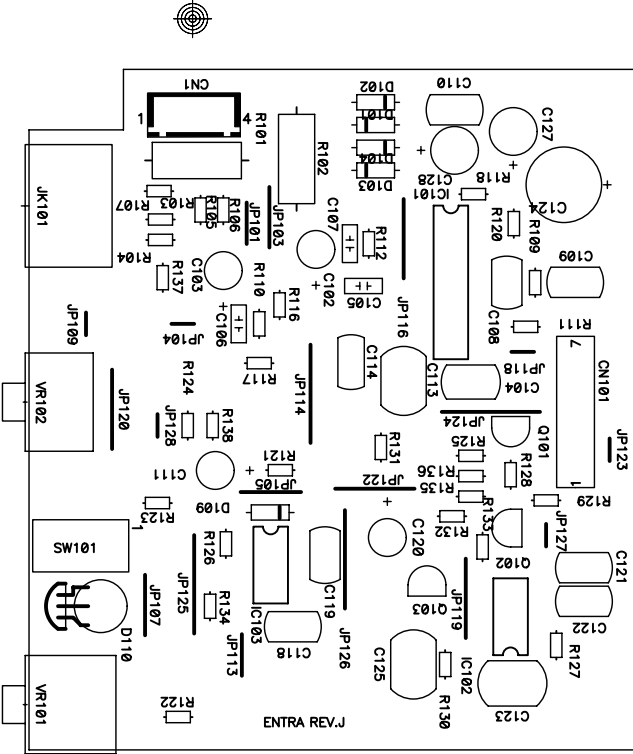

TOP SILK SCREEN

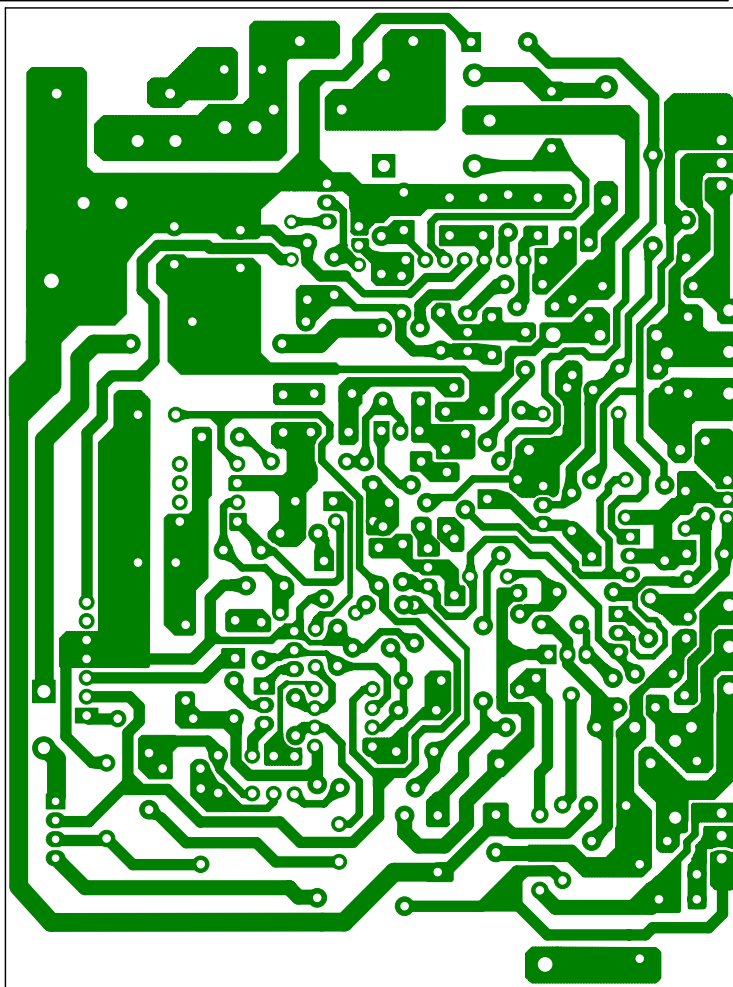
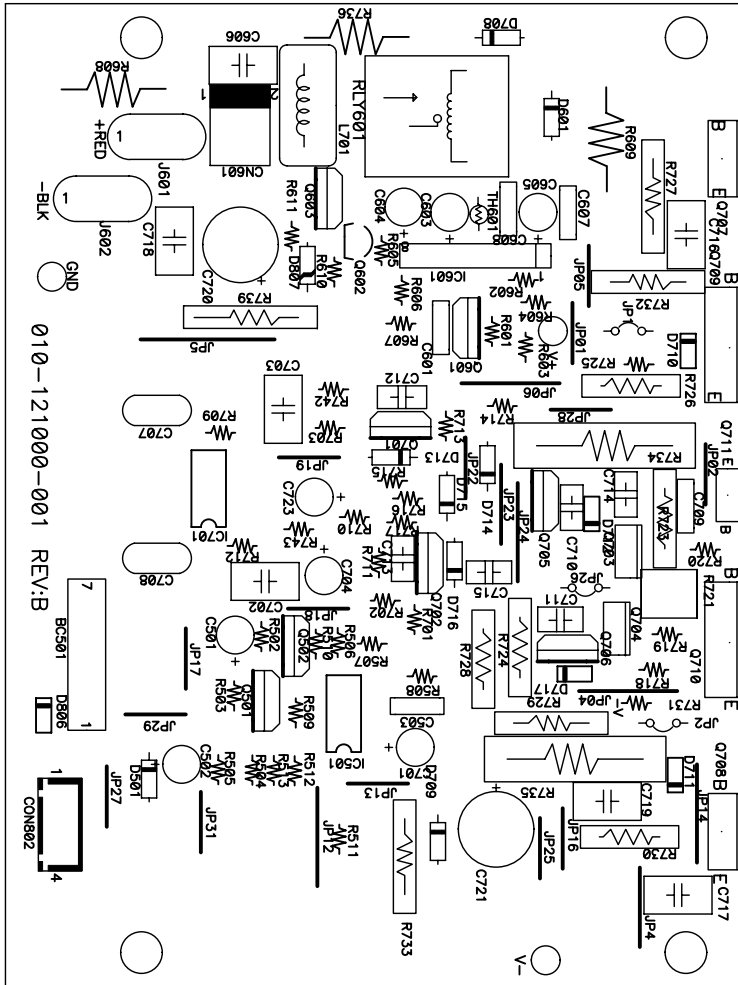

## Preamp Schematic

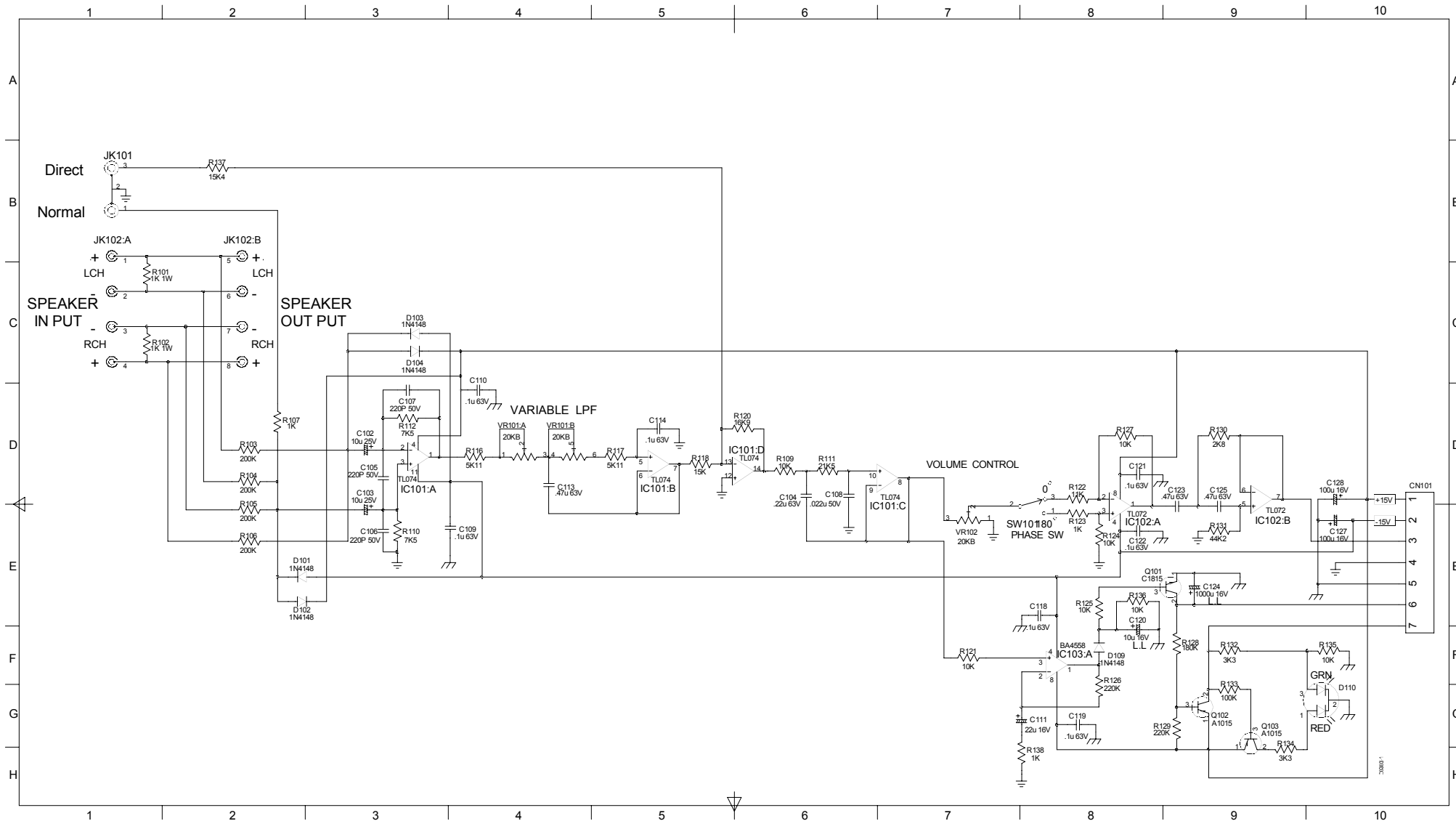

# Power Amp Schematic

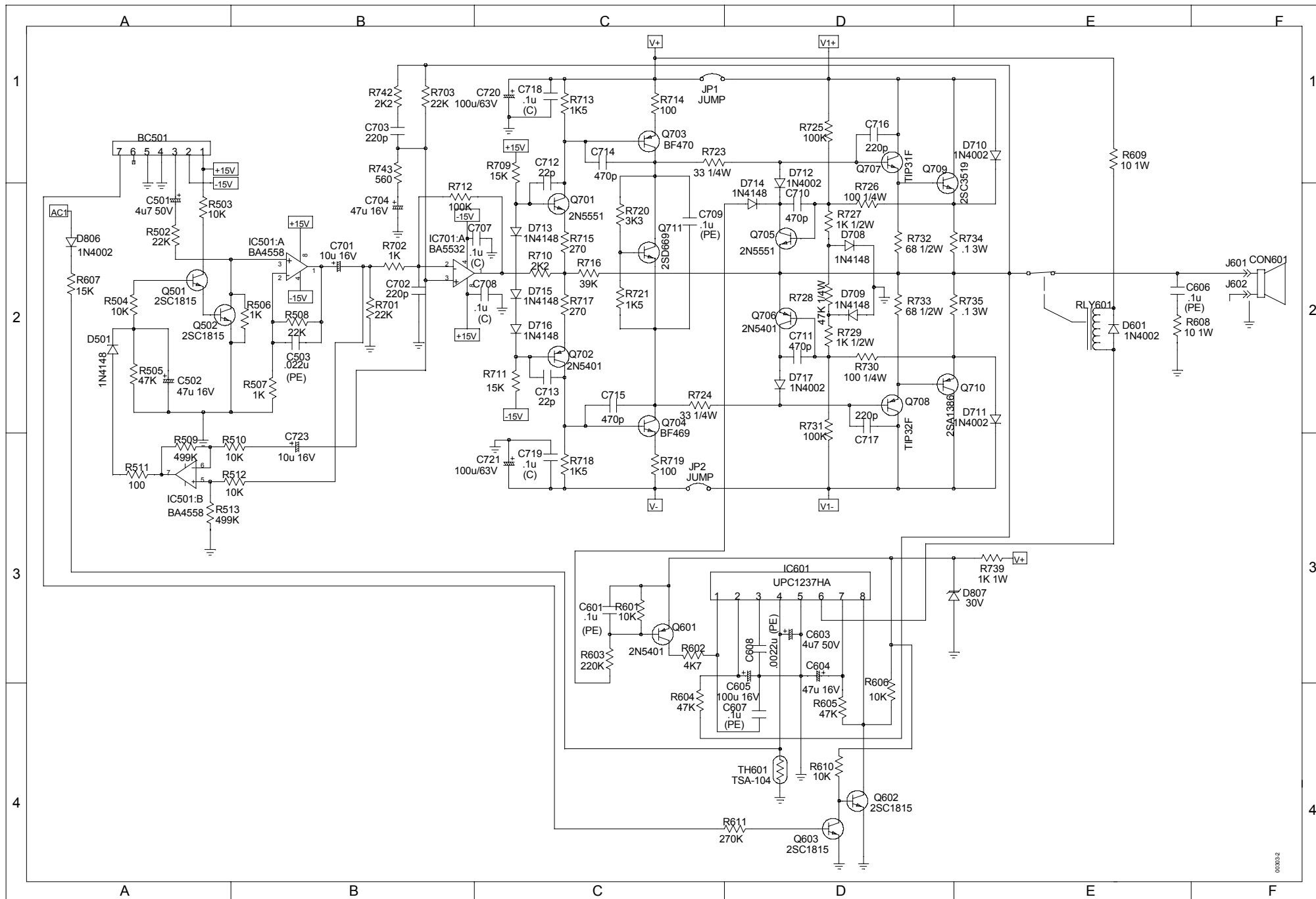



# Power Supply Schematic

