



PS Series

PS210 Subwoofer

SERVICE MANUAL



Infinity Systems, Inc.
250 Crossways Park Dr.
Woodbury, New York 11797

Rev1 8/2007

- CONTENTS -

BASIC SPECIFICATIONS	1
DETAILED SPECIFICATIONS.....	2
PACKAGING.....	4
CONTROLS AND CONNECTIONS.....	5
OPERATION.....	7
EXPLODED VIEW/PARTS LIST	8
TEST SET UP AND PROCEDURE.....	9
BLOCK DIAGRAM.....	10
ELECTRICAL PARTS LIST (120v)	11
PCB DRAWINGS.....	14
SEMICONDUCTOR PINOUTS.....	16
SCHEMATICS (120v).....	17

Basic Specifications PS210 Powered Subwoofer

Frequency Response:	27Hz – 150Hz (± 3 dB)
Maximum Amplifier Output:	300 Watts RMS; 500 Watts Peak (20Hz – 150Hz with no more than 0.1% THD)
Crossover Frequencies:	50Hz – 150Hz, 24dB/octave, continuously variable
Driver:	10" (254mm) MMD®
Dimensions (H x W x D): (with grille)	15-3/4" x 12-1/2" x 16-1/2" (400mm x 318mm x 419mm)
Weight:	38.6 lb (17.6kg)

Infinity continually strives to update and improve existing products, as well as create new ones. The specifications and construction details in this and related Infinity publications are therefore subject to change without notice.

Primus PS210		150W Powered Sub Amp				
LINE VOLTAGE						
	Yes/No	Hi/Lo Line	Nom.	Unit	Notes	
US 120vac/60Hz	Yes	108-132	120	Vrms	Normal Operation	
EU 230vac/50-60Hz	Yes	207-253	230	Vrms	Normal operation, MOMS required	
Parameter						
	Specification	Unit	QA Test Limits	Conditions	Notes	
Amp Section						
Type (Class AB, D, o her)	D	n/a	n/a			
Load Impedance (speaker)	4	Ohms	n/a	Nominal		
Rated Output Power (120VAC)	150	Watts	145		Domestic version only 120 VAC-60 Hz	
Rated Output Power (230VAC)	150	Watts			EU Version only 230 VAC-50-60 Hz	
AVG RMS Dynamic Power	210	Watts	200		Average RMS power, 3/20 Cycles 50 Hz, Driven 6dB above its input sensitivity, average of the first 4 consecutive peaks	
THD @ Rated Power	0.5	%	1	22K filter		
THD @ 1 Watt	0.2	%	0.3	22K filter		
DC Offset	10	mV-DC	30	Sub amp output		
Damping factor	>50	DF	35	Measured at amplifier board	Measured at the speaker cable. 150 Watts @ THD < 0.1 % @ 50 Hz	
Input Sensitivity-120V						
Input Frequency	50	Hz	50	Nominal Freq.		
L&R	9.5	mVrms	±1dB	To 1 Watt	Single input driven	
LFE input	9.5	mVrms	±1dB	To 1 Watt	Single input driven, LFE switch ON	
System Gain	46.72	dB	Reference		Single input driven Normal mode	
Input Sensitivity-230V						
Input Frequency	50	Hz	50	Nominal Freq.		
L&R	TBD	mVrms	±1dB	To 1 Watt	Single input driven	
LFE input	TBD	mVrms	±1dB	To 1 Watt	Single input driven, LFE switch ON	
System Gain	TBD	dB	Reference		Single input driven Normal mode	
Signal to Noise						
SNR-A-Weighted	90	dBA	85	relative to rated power	A-Weighting filter	
SNR-unweighted	80	dBr	75	relative to rated power	22K filter	
SNR rel. 1W-unweighted	-57	dBr	-55	relative to 1W Output	22K filter	
Residual Noise Floor	1.5	mVrms(max)	2.5	Volume @max, w/ A/P Swept Bandpass Measurement (Line freq.+ harmonics) (BW=20 KHz)	Line level inputs must be terminated using 1KOHM	
Input Impedance						
Line Input (L, R,LFE)	10K	ohms	n/a	Nominal		
Filters						
LP filter Variable	50-150	Hz	± 10		2nd order variable + 2nd order fix-24 db/Octave	
Subsonic filter (HPF) 2rd Order	Fixed				12dB/Octave F=31Hz, Q=2	
Friend circuit	Fixed				60Hz, Q=2, Av=-3.9dB	
LFE Low pass	200>LP<500	Hz		LFE input driven only		
Limiter						
THD at Max. Output Power	N/A	N/A	functional	Maximum Output Power	Maximum THD as a result of limiting.	
Features						
Volume pot Taper (lin/log)	LOG	--	functional		A Taper	
Phase switch	0-180	deg	functional			
LP Filter defeat switch	YES		functional		Disables LP filter, intended for LFE	
Input Configuration						
Line In (L,R) & LFE	YES	--	functional		Dual RCA jack	
Signal Sensing (ATO)						
Auto-Turn-On (yes/no)	YES		functional			
ATO Input test frequency	50	Hz	functional			
ATO Level LFE Input	2.5	mV	functional		Maximum acceptable level.	
ATO Turn-on time	5	ms	functional	Amp connected and AC on, then input signal applied		
Auto Mute/ Turn-OFF Time	5-15	minutes	5-15	T before muting, after signal is removed	Auto turn of time (T) must be 5 > T < 15 Minutes	
Power on Delay time						
	3	sec.	4	AC Power Applied		
Transients/Pops						
ATO Transient	0.5	V-peak	0.5V	@ Sub amp output	Amplifier activated by signal presence at the Line input	
Turn-on Transient	0.5	V-peak	0.8V	@ Sub amp output	AC Line cycled from OFF to ON	

Parameter	Specification	Unit	QA Test Limits	Conditions	Notes
Turn-off Transient	0.5	V-peak	0.8V	@ Sub amp output	AC Line cycled from ON to OFF
Efficiency					
Efficiency	60	%	58	Test conducted at rated power 150V	Nominal Line voltage
Efficiency at 1/8 of rated power	38	%	37	Test conducted at 18.75 WRMS	Nominal Line voltage-Rated impedance 4 Ohms
Off state input power	16	Watts	18		Nominal Line voltage RED LED
Stand-by Input Power	24	Watts	26	@ nom. line voltage	Maximum allowable input power under nominal Input voltage and frequency, HOT or COLD operation.LED GREEN no signal applied
Power Cons. @ rated power	250	Watts	260	@ nom. line voltage	150 Watts @ 4 Ohms nominal line voltage
Protections					
Short Circuit Protection	YES		functional	Direct short at output	Amplifier should resume operation after short circuit condition removal
Thermal Protection	YES		functional	@1/8 max unclipped Power at 1.06 times the input voltage	Temperature rise in accessible metal parts should not exceed 35K rise for domestic version or 30K rise for European versions (refer to requirements sheet).
DC Offset Protection	YES		-	DC present at Speaker Out leads	Design must insure no Offset at the speaker output under any operating condition including abnormal operation
Line Fuse Rating					
USA-Domestic	2	Amps	2	Type-T or Slo Blo-250 V	Internal fuse with UL/SEMKO rated holder
EU	1.25	Amps	1.25	Type-T or Slo Blo-250 V, Low Breaking capacity	Internal fuse with UL/SEMKO rated holder

PS210 PACKAGING

Owner's Manual
120v - 406-000-05520-E
230v - 406-000-05521-E

EPE Polyfoam: 431-000-05958-E 1PCS

Pearl PE Bag: 1PCS

EPE Polyfoam : 431-000-05959-E 1PCS

Outer Carton

PS210BE.....	400-000-07239-E	1PCS
PS210BE/230...	400-000-07240-E	1PCS
PS210BK.....	400-000-07247-E	1PCS
PS210BK/230...	400-000-07248-E	1PCS
PS210CH.....	400-000-07241-E	1PCS
PS210CH/230...	400-000-07242-E	1PCS

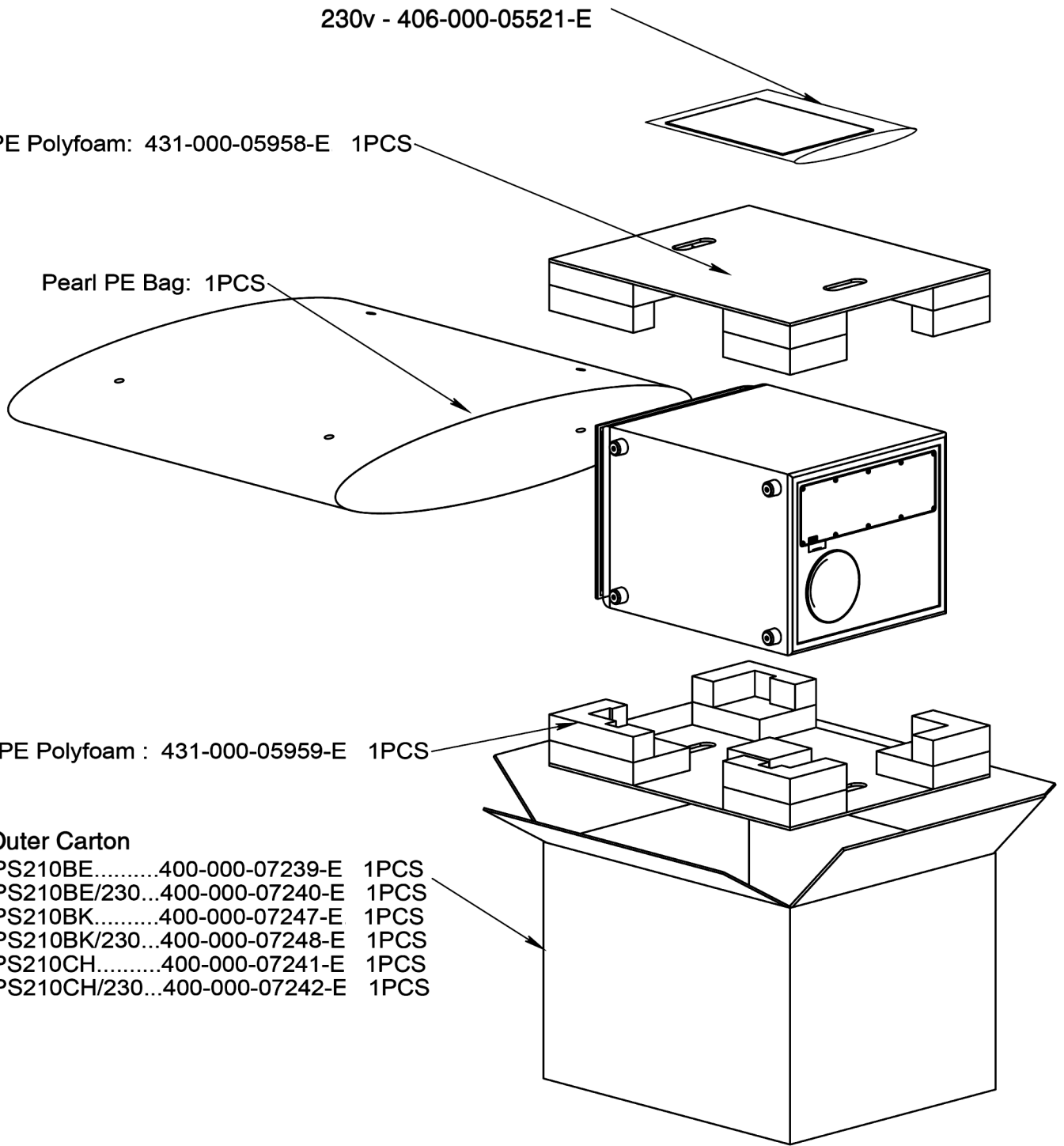

CONTROLS AND CONNECTIONS

Rear Panel

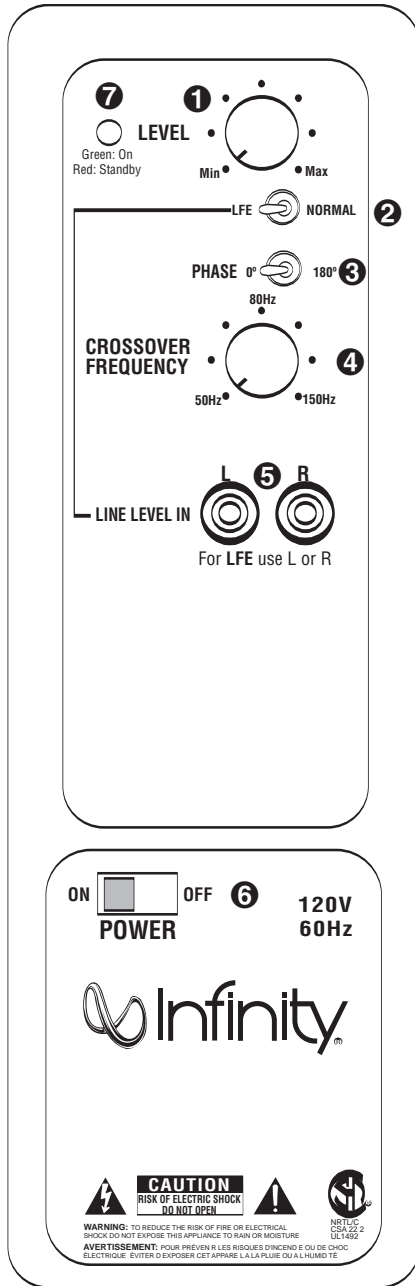

- 1 Subwoofer-Level Control
- 2 LFE/Normal Selector
- 3 Phase Switch
- 4 Crossover Adjustment
- 5 Line-Level/LFE Input
- 6 Power Switch
- 7 Status LED

SYSTEM CONNECTIONS

If you have a Dolby® Digital or DTS® receiver/processor with a low-frequency effects (LFE) or subwoofer output:

Set LFE/Normal switch to "LFE."

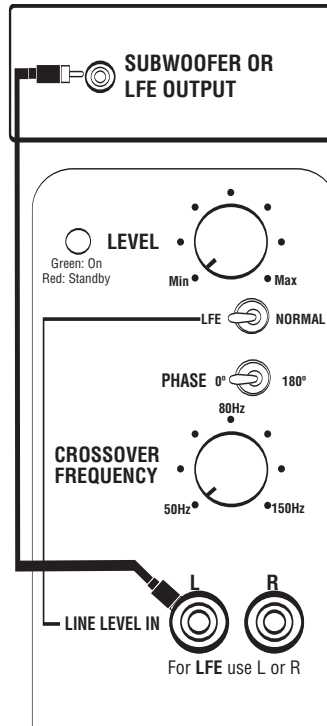

If your receiver/processor does not contain a Dolby Digital or DTS processor but has subwoofer outputs:

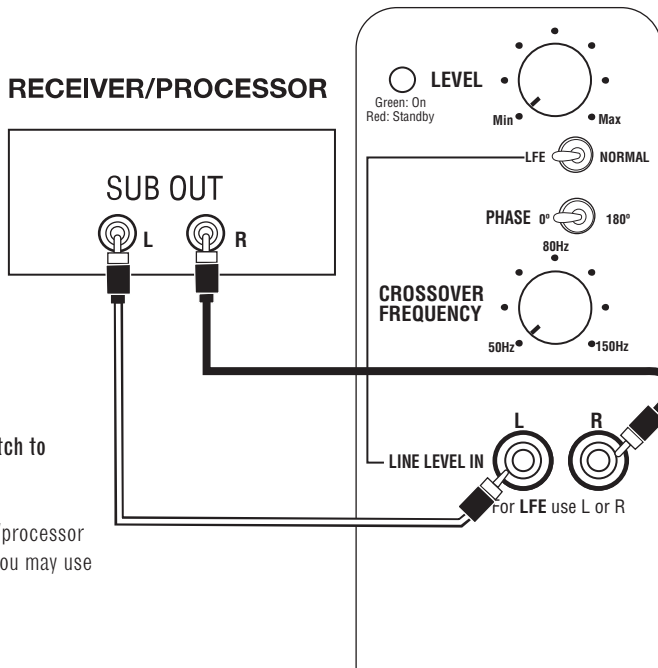

Set line-level/LFE switch to "Normal."

NOTE: If your receiver/processor has only one sub out, you may use either the L or R input.

OPERATION

Power On

Plug your subwoofer's AC cord into a wall outlet. Do not use the outlets on the back of the receiver.

Initially set the Subwoofer-Level Control **1** to the "min" position.

Turn on your sub by pressing the Power Switch **6** on the rear panel. Turn on your entire audio system and start a CD or movie soundtrack at a moderate level.

Auto On/Standby

With the Power Switch **6** in the ON position, the Status LED **7** on the back panel will remain lit in red or green to indicate the On/Standby mode of the subwoofer.

RED = STANDBY (No signal detected, Amp Off)

GREEN = ON (Signal detected, Amp On)

The subwoofer will automatically enter the Standby mode after approximately 10 minutes when no signal is detected from your system. The subwoofer will then power ON instantly when a signal is detected. During periods of normal use, the Power Switch **6** can be left on. You may turn off the Power Switch **6** for extended periods of nonoperation, e.g., when you are away on vacation.

Adjust Gain

Turn your Subwoofer-Level Control **1** up to the halfway position. If no sound emanates from the subwoofer, check the AC-line cord and input cables. Are the connectors on the cables making proper contact? Is the AC plug connected to a "live" receptacle? Has the Power Switch **6** been pressed to the "On" position? Once you have confirmed that the subwoofer is active, proceed by playing a CD, record or cassette. Use a selection that has ample bass information.

Set the overall volume control of the preamplifier or stereo to a comfortable level. Adjust the Subwoofer-Level Control **1** until you obtain a pleasing blend of bass. Bass response should not overpower the room but rather be adjusted so there is a harmonious blend across the entire musical range. Many users have a tendency to set the subwoofer volume too loud, adhering to the belief that a subwoofer is there to produce lots of bass. This is not entirely true. A subwoofer is there to enhance bass, extending the response of the entire system so the bass can be felt as well as heard. However, overall balance must be maintained or the music will not sound natural. An experienced listener will set the volume of the subwoofer so its impact on bass response is always there but is never obtrusive.

Phase Control

The Phase Switch **3** determines whether the subwoofer speaker's piston-like action moves in and out with the main speakers, 0°, or opposite the main speakers, 180°. Proper phase adjustment depends on several variables such as room size, subwoofer placement and listener position. Adjust the phase switch to maximize bass output at the listening position.

Crossover Adjustment

The Crossover Adjustment Control **4** determines the highest frequency at which the subwoofer reproduces sounds. If your main speakers can comfortably reproduce some low-frequency sounds, set this control to a lower frequency setting, between 50Hz and 100Hz. This will concentrate the subwoofer's efforts on the ultradeep bass sounds required by today's films and music. If you are using smaller bookshelf speakers that do not extend to the lower bass frequencies, set the Crossover Adjustment control to a higher setting, between 120Hz and 150Hz.

NOTE: This control will have no effect if the LFE/Normal Selector **2** is set to LFE. If you have a Do by Digital or DTS processor/receiver, the Low-Pass Frequency is set by the processor/receiver. Consult your owner's manual to learn how to view or change this setting.

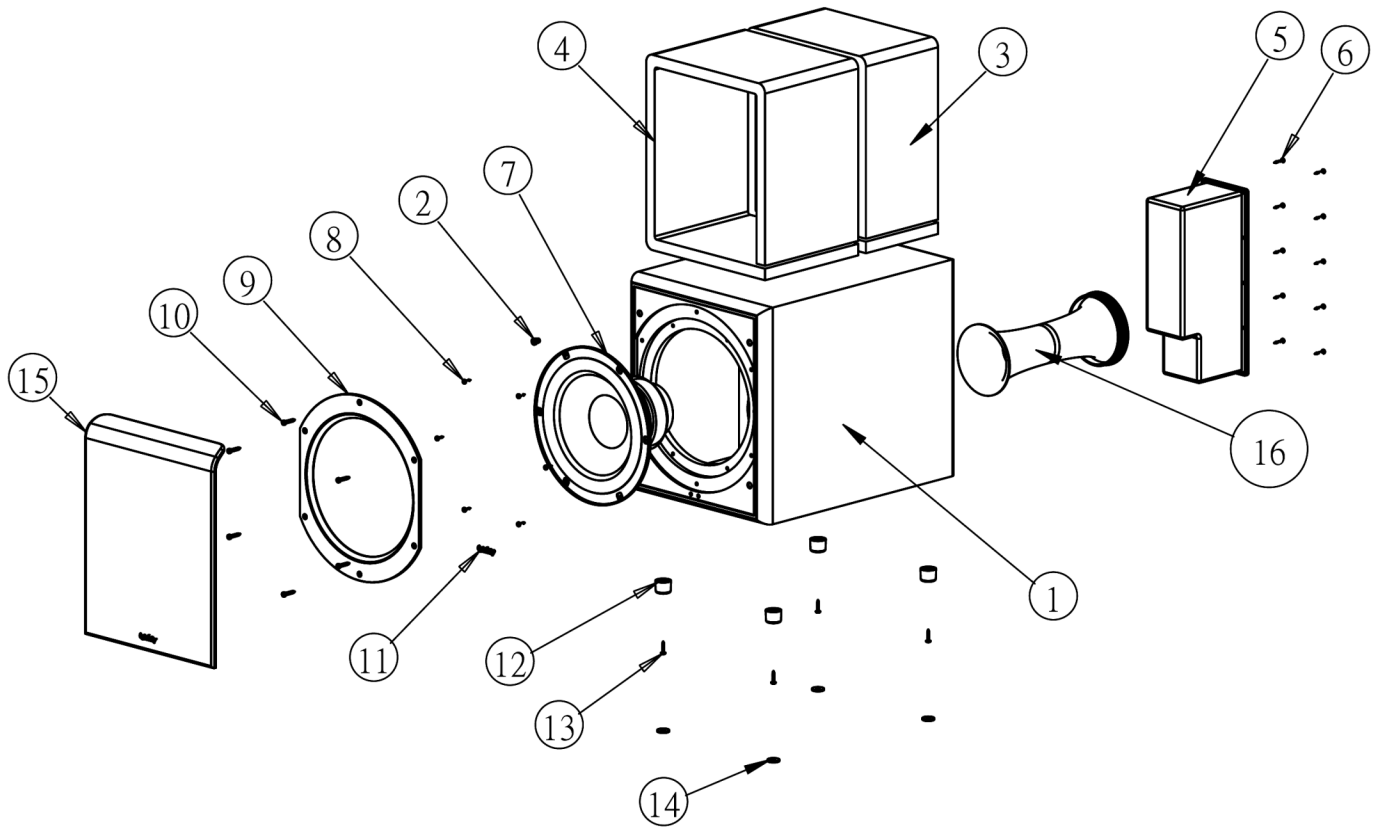

Item	Part Number	Description	Qty
1	Not for Sale	PS210 Cabinet BE/BK/CH	1
2	327-010-00624-E	Grille Cup	4
3	Not for Sale	Dacron (Acoustic damping)	1
4	Not for Sale	Dacron (Acoustic damping)	1
5	Not for Sale	PS210 Amplifier	1
6	352-AM04020D210-E	Screw, Amplifier	10
7	351510-001	10" Woofer DCR=3.4 ohms ±10%	1
8	352-FM04014D609-E	Screw, Woofer	6
9	213-100-05147-0VAE	10" Trim ring	1
10	352-DM04525D597-E	Screw, Trim ring	6
11	316-ABS-05218-0VAE	Infinity Logo	1
12	320-ABS-00195-E	Plastic Foot	4
13	352-CM04025D604-E	Screw, Plastic Foot	4
14	320-RUB-00199-E	Rubber Foot Cushion for Feet	4
15	244-100-05227-0VAE	Front Grille (Platinum)	1
	244-100-05227-0BAE	Front Grille (Black)	1
16	Not for Sale	Port Tube	1

PS210 sub Test Set Up and Procedure

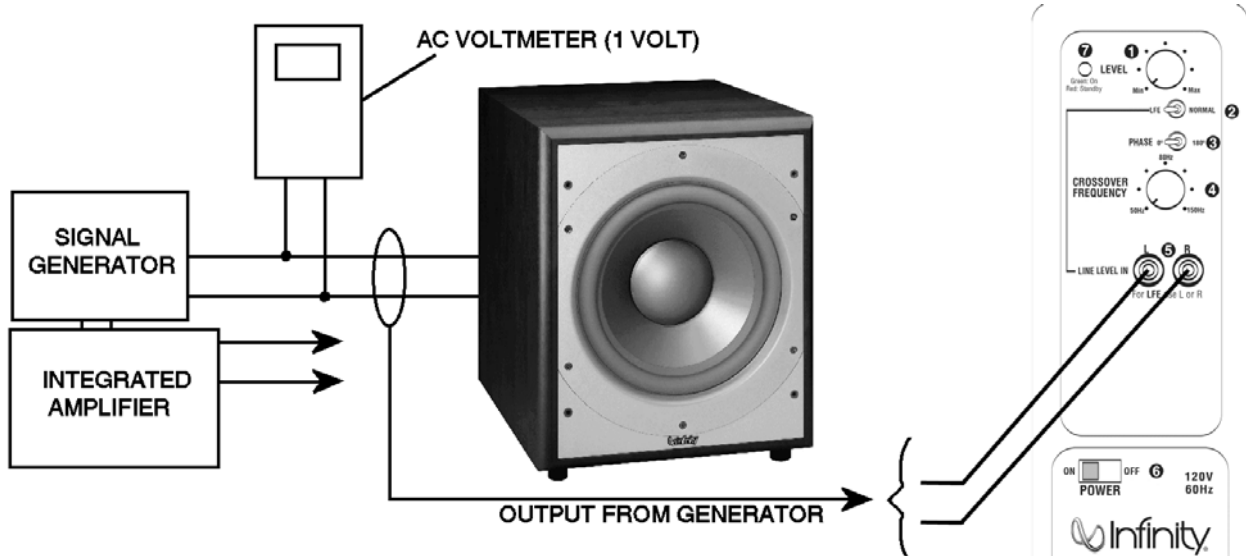

SYSTEM AURAL SWEEP TEST

Equipment needed:

- Function/signal generator/sweep generator
- Integrated Amplifier
- Multimeter
- Speaker cables

General Unit Function (UUT = Unit Under Test)

Switches/knobs on the amplifier faceplate:

Crossover Frequency Adjust full CW (Max)

Phase switch – either position

Normal/LFE switch - Normal

1. From the signal generator, Connect both right and left line level inputs (RCA jacks) – to signal generator and UUT. Use Y-cable if necessary from mono source.
2. On the amplifier, turn the LEVEL control full Counterclockwise (Min).
3. Turn on generator, adjust to **75mV, 50 Hz**.
4. Plug in UUT; turn the power switch ON. Turn LEVEL control full Clockwise (Max).
5. LED (on amp panel) should now be Green; immediate bass response should be heard and felt from rear port tube opening.

Sweep Function

1. Follow steps 1-5 above, using a sweep generator as a signal source.
2. Sweep generator from 20Hz to 1kHz. Listen to the cabinet and drivers for any rattles, clicks, buzzes or any other noises. If any unusual noises are heard, remove woofer and test.

Driver Function (Woofer)

1. Remove woofer from cabinet; detach + and - wire clips.
2. Check DC resistance of woofer; it should be **3.4 ohms \pm 10%**.
3. Connect a pair of speaker cables to driver terminals. Cables should be connected to an integrated amplifier fed by a signal generator. Turn on generator and adjust so that speaker level output is **5.0V**.
4. Sweep generator from 20Hz to 1kHz. Listen to driver for any rubbing, buzzing, or other unusual noises.

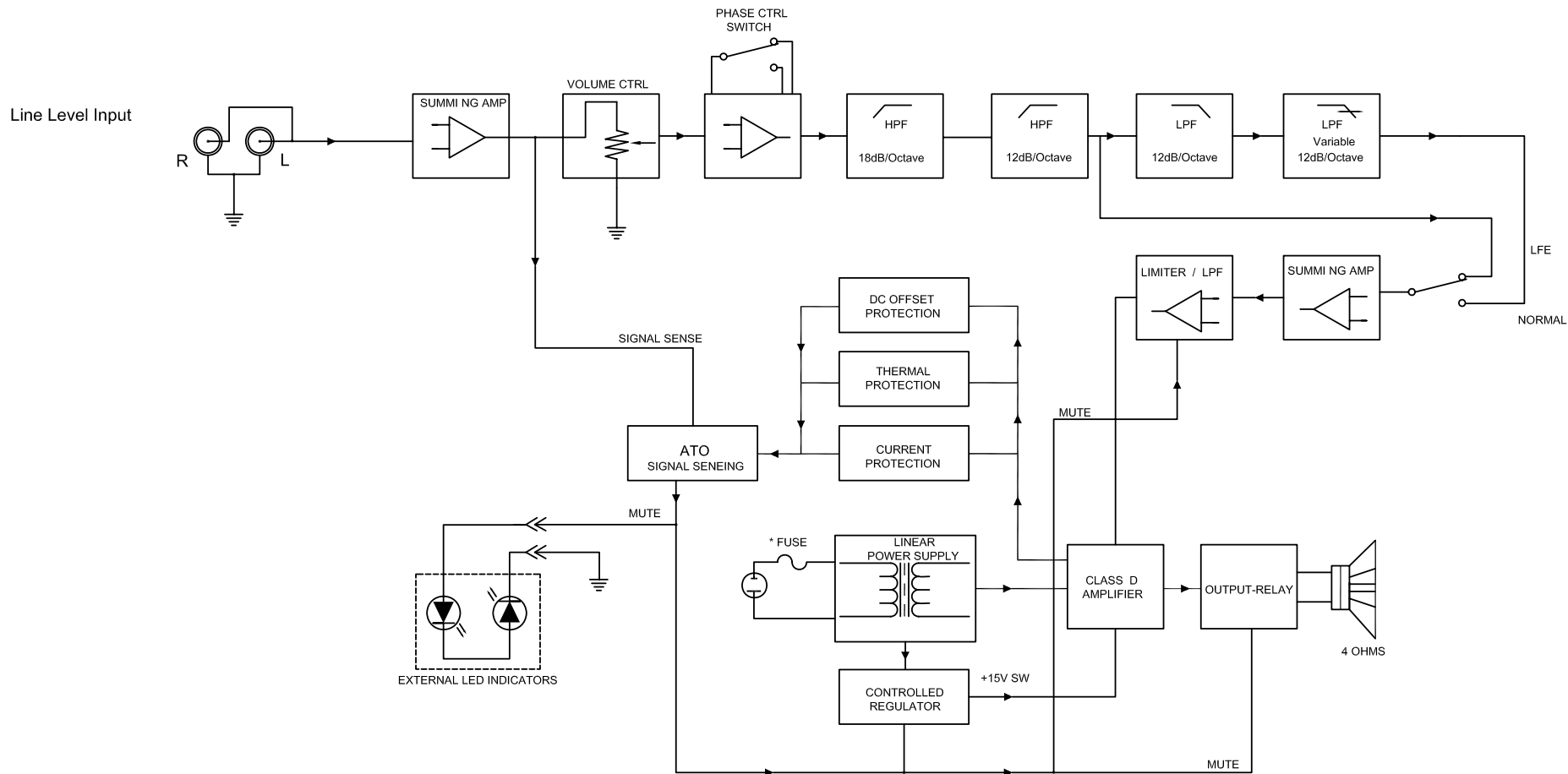

NOTE :
 120 VAC T1.25A-250V
 230 VAC T0.8A-250V

PS210 Electrical Parts List			
Part number	Qty	Description	Reference Designator
PREMAP/MAIN/POWER PCB			
<i>Capacitors</i>			
034-330525-300ZR	1	GR Electrolytic cap. 33uF/25V M (R)0511 P:5	C1
033-680464-270ZS	1	GS NPE Cap. 甲ELYTONE 6u8/100V K10 (R)1020 GNE	C72
032-100484-200ZS	1	GS END Mylar cap. 1uF/250V K P:15	C70,
033-470464-270ZS	1	GS NPE Cap.(甲ELYTONE)1K 4u7/100V K10 (R)1015 GNE	C73
031-100343-100ZS	1	GS SMD Cap. 100pF/50V J 0805 NPO	C58
034-220525-301ZS	2	GS Electrolytic cap. 22uF/25V M (R)5x11 P:5	C50,53
031-560243-100ZS	2	GS SMD Cap. 56pF/50V J 0805 NPO	C57,61
031-220243-103AZ	1	GS SMD Cap. 0u022/50V J 0805 X7R	C84,
031-100344-100ZS	17	GS SMD Cap. 0u1/50V K 0805 X7R	C42-44,46-49,52,55,60,63,71,74,77,100,101,80
031-100244-100ZS	4	GS SMD Ceramic cap. 0u01/50V K 0805 X7R	C45,51,66,67,
034-470515-307ZR	1	GR Electrolytic cap.LOW ESR 85°C 47uF/16V M (R)0511 P:5	C65
031-100344-100ZS	1	GS SMD Cap. 0u1/50V K 0805 X7R	C54
034-100625-300ZS	1	GS Electrolytic cap. 100uF/25V M (R)6.3x11 P:5	C64
031-470244-102ZS	2	GS SMD Cap. 0u047/50V K 0805 X7R	C62,59
031-560343-102ZS	1	GS SMD Cap. 560pF/50V J 0805 NPO	C56
034-330615-300ZS	1	GS Electrolytic cap. 330uF/16V M (R)0812 P:5	C78
031-100344-100AZ	2	GS SMD Cap. 0u1/50V K 0805 X7R	C81,82
035-100393-301ZR	2	GR Mylar cap.(ESK TYPE) 0u1/63V J P:5 PN:ESK063S10JT	C28,2A,
035-220393-300ZR	1	GR PE Cap. 0u22/63V J P:5	C27,
034-470415-301ZS	1	GS Elect. Cap. 4u7/50V M (R)0511 P:5	C2
034-100525-300ZS	3	GS Electrolytic cap. 10uF/25V M (R)0511 P:5	C35,237,238,
031-100244-100ZS	2	GS SMD Ceramic cap. 0u01/50V K 0805 X7R	C5,10
031-100343-100ZS	2	GS SMD Cap. 100pF/50V J 0805 NPO	C16,36
031-100344-100ZS	1	GS SMD Cap. 0u1/50V K 0805 X7R	C11
031-100384-100RZ	2	GS SMD Cap. 0u1/250V K 1206 X7R	C3,7
031-220243-103AZ	1	GS SMD Cap. 0u022/50V J 0805 X7R	C40
031-220344-100ZS	5	GS SMD Cap. 220pF/50V J 0805 NPO	C14,15,20,21,19
031-330244-100ZR	1	GR SMD Cap. 0u033/50V K 0805 X7R	C33,
031-680444-102ZR	2	GR SMD Cap. 6800pF/50V K X7R 0805	C32,34,
032-270343-301ZS	3	GS Mylar cap. (MP) 0u27/63V J P:5	C29,26,25
032-820244-200ZR	1	GR Mylar cap. 0u082/100V K (R)	C30
034-220515-302ZR	2	GR elect. Cap. 22uF/16V M (R)0511 P:5	C39,75
034-220525-301ZS	4	GS 22uF/25V M (R)5x11 P:5	C4,9,41,76
034-330615-300ZS	1	GS 330uF/16V M (R)0812 P:5	C12
034-330780-300ZR	2	GR 85°C SNAPIN 330uF/80V M (R)22x48	C6,8
034-470515-200ZR	1	GR 47uF/16V M (R)0511 P:2.5	C37
039-100384-100ZR	1	GR Safety cap. (0u1/250V) .1K275VACx2 18x6x12mm	CXAC1
034-100615-301ZS	1	GS electrolytic cap. 100uF/16V M (R)0611 P:5	C83
031-100344-100ZS	2	GS SMD Capacitor 0u1/50V K 0805 X7R	C102,103,
031-100444-104ZR	1	GR SMD Capacitor 1000pF/50V K 0805 X7R	C104
<i>Resistors</i>			
024-100398-120ZR	1	GR SMD Resistor 100R 1/8W J 0805	R62
020-220497-120ZR	1	GR Carbon Resistor 2K2 1/4W J	R11
024-100298-120ZR	2	GR SMD Resistor 10R 1/8W J 0805	R81,82
021-100401-120ZR	1	GR MOF Resistor 1K 1W J INK MO-100	R103
024-470498-120ZR	2	GR SMD Resistor 4K7 1/8W J 0805	R85,86
022-500003-020ZR	1	GR Resistor KNP 0R05 3WS J FK TYPE	R104
024-220798-120ZR	1	GR SMD Resistor 2M2 1/8W J 0805	R80
024-430498-120ZR	1	GR SMD 4K3 1/8W J 0805	R78
024-300498-120LZ	1	GR SMD 3K 1/8W J 0805	R105,
024-470598-120ZR	1	GR SMD 47K 1/8W J 0805	R107
024-220598-120ZR	1	GR SMD 22K 1/8W J 0805	R118,
024-680498-120ZR	6	GR SMD 6K8 1/8W J 0805	R91
024-110598-100ZR	1	GR SMD 11K 1/8W F 0805	R98
024-200598-120ZR	1	GR SMD 20K 1/8W J 0805	R94
024-100698-120ZR	2	GR SMD 100K 1/8W J 0805	R3,112
024-100598-120ZR	18	GR SMD 10K 1/8W J 0805	R2,74,75,84,88,89,97,106,113-117,119,120, 141,138,139,

Part number	Qty	Description	Reference Designator
PREMAP/MAIN/POWER PCB			
024-100498-120ZR	7	GR SMD 1K 1/8W J 0805	R79,83,92,95,96,110,145,
024-590498-100ZR	1	GR SMD 5K9 1/8W F 0805	R140,
024-270498-120ZR	1	GR SMD 2K7 1/8W J 0805	R73
024-442498-100ZR	1	GR SMD 4K42 1/8W F 0805	R128
024-200498-120ZR	1	GR SMD 2K 1/8W J 0805	R108
024-300598-120ZR	1	GR SMD 30K 1/8W J 0805	R131,
024-150598-100ZR	2	GR SMD 15K 1/8W F 0805	R132,133,
024-470698-120ZR	2	GR SMD 470K 1/8W J 0805	R129,130,
024-390598-120ZR	1	GR SMD 39K 1/8W J 0805	R77
024-470298-120ZR	2	GR SMD 47R 1/8W J 0805	R101,102
024-390498-120ZR	1	GR SMD 3K9 1/8W J 0805	R93
024-220398-120ZR	1	GR SMD 220R 1/8W J 0805	R90
024-470398-120ZR	3	GR SMD 470R 1/8W J 0805	R76,99,100
024-330498-100ZR	2	GR SMD 3K3 1/8W F 0805	R127,137,
024-220498-121ZR	2	GR SMD 2K2 1/8W J 0805	R1,87,
024-162598-100ZR	4	GR SMD 16K2 1/8W F 0805	R125,126,135,136,
024-000098-120ZR	1	GR SMD Resistor 0R 1/8W J 0805	R68
024-100498-120ZR	3	GR SMD Resistor 1K 1/8W J 0805	R65,44,151,
024-100598-100ZR	5	GR SMD 10K 1/8W F 0805	R146,147,30,31,33,
024-100598-120ZR	11	GR SMD 10K 1/8W J 0805	R17,19,,54,58,63,71,72,111,123,124,134,
024-100898-120ZR	1	GR SMD 10M 1/8W J 0805	R121
024-130498-100ZR	1	GR SMD 1K3 1/8W F 0805	R5A
024-150498-120ZR	1	GR SMD 1K5 1/8W J 0805	R67
024-150598-100ZR	3	GR SMD 15K 1/8W F 0805	R29,
024-160698-120ZR	1	GR SMD 160K 1/8W J 0805	R152,
024-220498-121ZR	2	GR SMD 2K2 1/8W J 0805	R61,57,
024-237598-120ZR	1	GR SMD 23K7 1/8W F 0805	R48
024-243498-100ZR	1	GR SMD 2K43 1/8W F 0805	R36
024-270498-120ZR	1	GR SMD 2K7 1/8W J 0805	R64
024-300598-120ZR	1	GR SMD 30K 1/8W J 0805	R56,
024-330498-120ZR	8	GR SMD 3K3 1/8W J 0805	R7,8,12-15,59,55,
024-330598-120ZR	2	GR SMD 33K 1/8W J 0805	R4,5
024-332498-100ZR	2	GR SMD 3K32 1/8W F 0805	R26,27
024-470498-121ZR	3	GR SMD 4K7 1/4W J 1206	R148-150,
024-470598-120ZR	2	GR SMD 47K 1/8W J 0805	R47,49
024-470698-120ZR	1	GR SMD 470K 1/8W J 0805	R70,
024-470798-120ZR	1	GR SMD 4M7 1/8W J 0805	R60
024-475498-100ZR	1	GR SMD 4K75 1/8W F 0805	R38
024-511398-100ZR	1	GR SMD 511R 1/8W F 0805	R6A
024-560598-120ZR	1	GR SMD 56K 1/8W J 0805	R122
024-619498-100ZR	2	GR SMD 6K19 1/8W F 0805	R51,53
024-619598-100ZR	1	GR SMD 61K9 1/8W F 0805	R4A
024-620398-100ZR	2	GR SMD 620R 1/8W F 0805	R16,18
024-680498-120ZR	5	GR SMD 6K8 1/8W J 0805	R46,40-43
024-680598-120ZR	1	GR SMD 68K 1/8W J 0805	R66,
024-681598-100ZR	2	GR SMD 68K1 1/8W F 0805	R50,52,
024-750398-101ZR	1	GR SMD 750R 1/8W F 0805 TPAING	R2A
024-750498-100ZR	1	GR SMD 7K5 1/8W F 0805	R35A
024-750598-100ZR	1	GR SMD 75K 1/8W F 0805	R45
024-820598-120ZR	2	GR SMD 82K 1/8W J 0805	R69,39,
026-200595-269ZS	1	GS VR PN:RD163121R03D-20KBx2(EJ) FREQUENCY	VR2
026-500495-005ZS	1	GS VR 5K PN:RD163111R22B-5K15A-EJ LEVEL	VR1
024-100598-120ZR	2	GR SMD Resistor 10K 1/8W J 0805	R142,144
024-270598-120ZR	1	GR SMD Resistor 27K 1/8W J 0805	R143
Semiconductors			
054-033904-100ZR	1	GR SMD (TRANSISTOR) PN:MMBT3904LT1G SOT23 (O	Q28
054-055500-100ZR	1	GR SMD IC: PN:NE555DR S08 (TI) TMER	U10
054-033906-100ZR	3	GR SMD Transistor (ON) PN:MMBT3906LT1G SOT23	Q10,12,15
051-640001-000ZR	2	GR MOSFET N-Channel PN:IRF640NPBF TO-220 (IR)	Q18,22
054-033904-100ZR	4	GR SMD (TRANSISTOR) PN:MMBT3904LT1G SOT23 (O	Q11,14,13,27
051-222200-100ZR	1	GR Transistor NPN (ON SEM) PN:MPS2222ARLRAR TO-92	Q21
051-000600-100ZR	1	GR Transistor NPN PN:MPSW06RLRA TO-92 (ON)	Q16

Part number	Qty	Description	Reference Designator
PREMAP/MAIN/POWER PCB			
054-540100-100ZR	3	GR SMD Transistor PNP (ON SEN) MMBT5401 LT1 SOT-23	Q20
051-555100-000ZR	1	GR Transistor NPN PN:2N5551 TO-92	Q17
051-290700-100ZR	2	GR Transistor PNP (ON) PN:MPS2907A RLRAR TO-92	Q19,23
051-540101-000ZR	1	GR Transistor PNP(FAIRCHILD PN:2N5401 TO-92	Q1
054-414803-100ZS	13	GS SMD DIODE: PN:LL4148 MINI-MELF	D1,2,27,31,34,44,40-43,46,47,45,
054-008409-000ZR	1	GR SMD ZENER DIODE: PN:BZX84C3V0-7-F SOT-23	D25
054-008406-000ZR	1	GR SMD ZENER DIODE:PN:BZX84C10-7-F SOT-23	D35
054-008408-000ZR	2	GR SMD ZENER DIODE: PN:BZX84C5V6-7-F SOT-23	D36,37
054-000100-100ZR	4	GR GS SMD DIODE: PN:ES1D 200V 1A (PANJIT)	D5,26,29,33
054-007200-100ZR	3	GR SMD IC PN:TL072CDR SO-8 (TI) DUAL OP-AMP	U6,8,1,
053-211100-000ZR	1	GR IC:DIP,PN:IR2111 8PIN (IR) HALF-BRIDGE DRIVER	U7
051-011100-100ZR	1	GR JFET N-Channel PN:J111 TO-92 (FAIRCHILD	Q200
054-000100-100ZR	1	GR GS SMD DIODE: PN:ES1D 200V 1A (PANJIT)	D38
054-007200-100ZR	4	GR SMD IC PN:TL072CDR SO-8 (TI)	U5
054-007400-100ZR	2	GR SMD IC:(OP) PN:TL074CDR (TI)	U2,3
054-008407-000ZR	3	GR SMD ZENER DIODE: PN:BZX84C15-7-F SOT-23	D6,7,9
054-011400-100ZR	1	GR SMD Transistor PN:DTC114TKA SMT3 (ROHM	Q7
054-033904-100ZR	4	GR SMD (TRANSISTOR) PN:MMBT3904LT1G SOT23 (O	Q5,8,25,9
054-033906-100ZR	1	GR SMD Transistor (ON) PN:MMBT3906LT1G SOT23	Q6,
054-045580-100ZS	1	GS SMD IC:(OP) PN:NJM4558M-TE3- DUAL OP-AMP	U4
054-414803-100ZS	15	GS SMD DIODE: PN:LL4148 MINI-MELF	D3,4,8,30,39,11,14,16,17,20,22,18,19,28,32,
054-524201-100ZR	1	GS SMD ZENER DIODE: PN:MMBZ5242B 12V SOT-23	D206,
054-540100-100ZR	2	GR SMD Transistor PNP (ON SEN) MMBT5401 LT1 SOT-23	Q24,26
051-024100-000ZR	1	GR Transistor DIP PN:MJE241 TO-126 (CENTRAL) NPN	Q2
051-025100-000ZR	1	GR Transistor DIP PN:MJE251 TO-126 (CENTRAL) PNP	Q3
052-400080-000ZR	1	GR Bridge Rectifier PN:RS804 400V,8A	BR1
051-003100-000ZS	1	GS Transistor NPN PN:TIP 31C TO-220 (MOSPEC)	Q4
050-505200-001ZS	1	GS LED PN:LT-2402-21	
Miscellaneous/Mechanical			
025-010300-000ZR	1	GR Thermister PN:NTSE103KZ072 K L:50mm	TH1,
074-300018-000ZR	1	GR RELAY PN:943-1C-48D	K1
043-560200-000ZR	1	GR INDUCTOR 56uH YT-10779	L1
043-300101-000ZR	1	GR INDUCTOR PN:YT-10033 30uH	L2
043-700101-000ZR	1	GR TOROIDAL INDUCTOR 70uH YT-10682	L3
041-115001-000ZR	1	GR BEAD COIL PN:YT-10911	L5
044-100100-000ZR	2	GR SMD FERRITE BEAD PN:321611 600R/100MHz 1206	FB1,FB2
074-020018-000ZR	1	GR ROCKER SW (POWER) PN:RF1003-BB4-0	
093-105202-300ZR	1	GR FUSE:UL GSL(2AG) FUSE:2A,250V,5*20mm 120V	F1 (120V)
093-205001-320ZR	1	GR FUSE: VBS UTE1.25A,250V,5*20mm 230V	F1 (230V)
042-010053-003ZR	1	GR Transformer YT-10616-4 for 120V	(120V)
042-018600-000ZR	1	GR Transformer YT-10913 for 230V	(230V)
061-020000-000ZS	2	GS Knob ABS HTS-10/20 φ20x15m/m UL94V-0 BLK	LEVEL, FREQUENCY
061-314002-000ZS	2	GS Strain Relief PN:SB4F-2	
061-400014-000BZ	4	GR RUBBER FOOT ID:6.2 OD:11.5 t:2mm 55 BLK	for Transformer
061-700044-000ZR	3	GR Mica 13x18mm TO-220	
063-010012-000ZR	4	GR Bracket for Transistor P/N:TRK-1	
063-321101-000ZR	1	GR Panel 322x105.7x15mm BLK ABS-94VC	
063-531808-000ZR	1	GR bucket (PB-10/12) ABS 322x105.7x146.5mm BLK (94VO)	
073-011006-400ZR	1	GR BRACKET 16x34mm t:0.8mm	PCB
073-032315-601ZS	1	GS Heatsink black anodized 70x58x20mm	
082-022607-000BZ	1	GR Wire set #26 UL1007 L:74mm 2P HOUSING	CON3B1,
086-021818-005ZR	1	GR Power Cord NISPT-2 18AWGx2 L:1830mm 105C+T187	(120V)
086-021820-001ZR	1	GRPower cord L:2.0M H05VV-F2x0.75WS019+002E for 230V	(230V)
043-000051-000ZR	1	GR COIL PN:YT-53015	L6
043-324300-000ZR	1	GR INDUCTOR 324uH YT-10778	L4
072-010305-000ZS	1	GS RCA JACK PN:B217BK 2P INPUT	CONN1
072-040169-000ZR	1	GR CONNECTOR PN:JS-1001-2 2P P:2.5mm	CON3A1
073-050001-000ZS	2	GS FUSE CLIP P/N:CT-FH1206	
074-030002-000ZR	2	GR TOGGLE SW PN:L101-T2B4QE LFE, PHASE	SW5,SW6
072-040720-000ZR	1	GR HEADER Right Angle PN:JS-1109R-04(S1)	

PS series PS210 subwoofer



ELYTONE (LIGHTION)

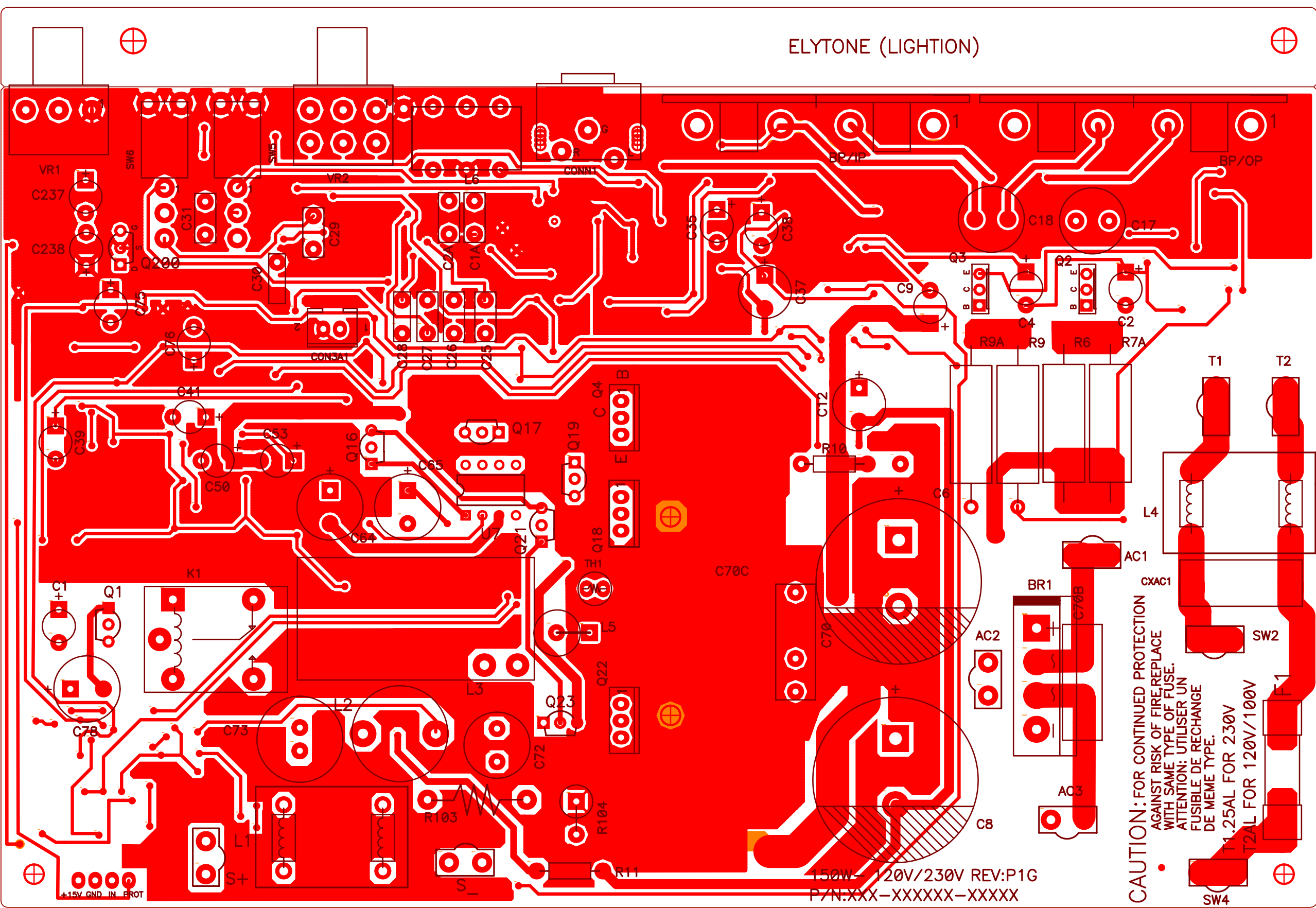

CAUTION: FOR CONTINUED PROTECTION
AGAINST RISK OF FIRE, REPLACE
WITH SAME TYPE OF FUSE.
ATTENTION: UTILISER UN
FUSIBLE DE RECHANGE
DE MEME TYPE.
T1: 25A FOR 230V
T2: 2A FOR 120V/100V

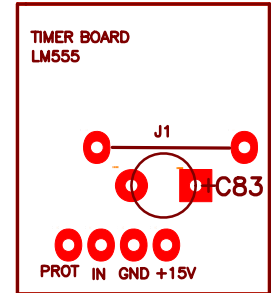

RECOMPONENTESIDEONCOMPONENT SIDE

Integrated Circuit Diagrams

IR2111 HALF BRIDGE DRIVER

Functional Block Diagram

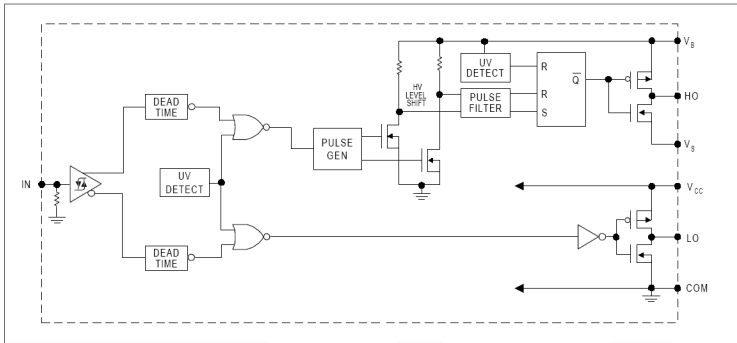

OPAMP, QUAD 14P TL074
U2,3

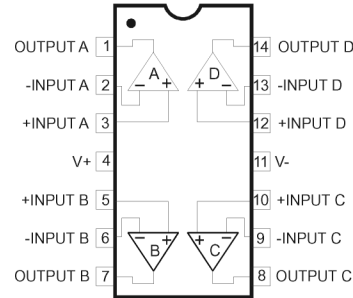

MOSFET,
IRF640 T0220
Q18,22

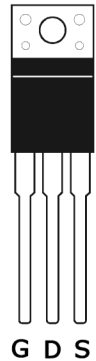

TRANS, NPN T0220
TIP31C Q4

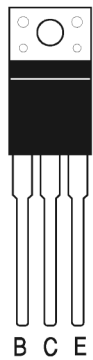

IR2111 U7

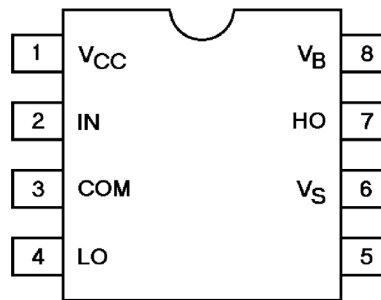

OPAMP, DUAL 8PIN
TL072, NJM4558M
U1,4-6,8

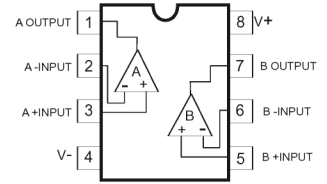

MJE241, MJE251
Q2,3



1. Emitter
2. Collector
3. Base

NE555 timer
U10

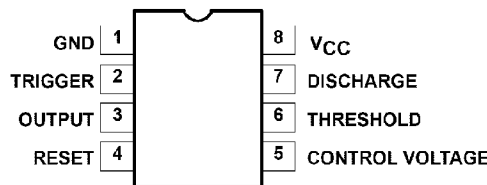

- * MMBT3904LTI SOT23,
- * MMBT3906LTI SOT23,
- DTC114TK SMT3
- * MMBT5401 LTI

Q5-15,20,24-27,28

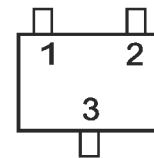

- 1) Emitter
- 2) Base
- 3) Collector

* PREFIX MAY BE "FMMT"

TRANS NPN
MPS2222A, 2N5551
Q17,21

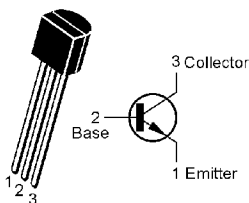

TRANS NPN
MPSW06
Q16

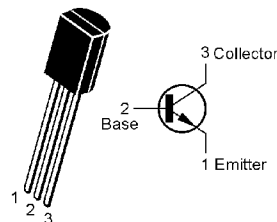

J111 FET
Q200

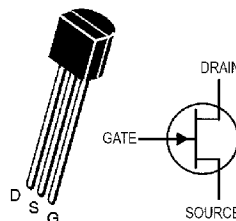

TRANS PNP
MPS2709A, 2N5401
Q1,19,23

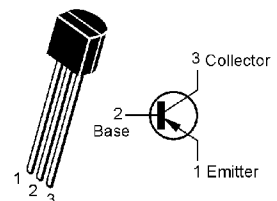

PS series PS210 subwoofer



Note:
No speaker input or outputs
are used in this model

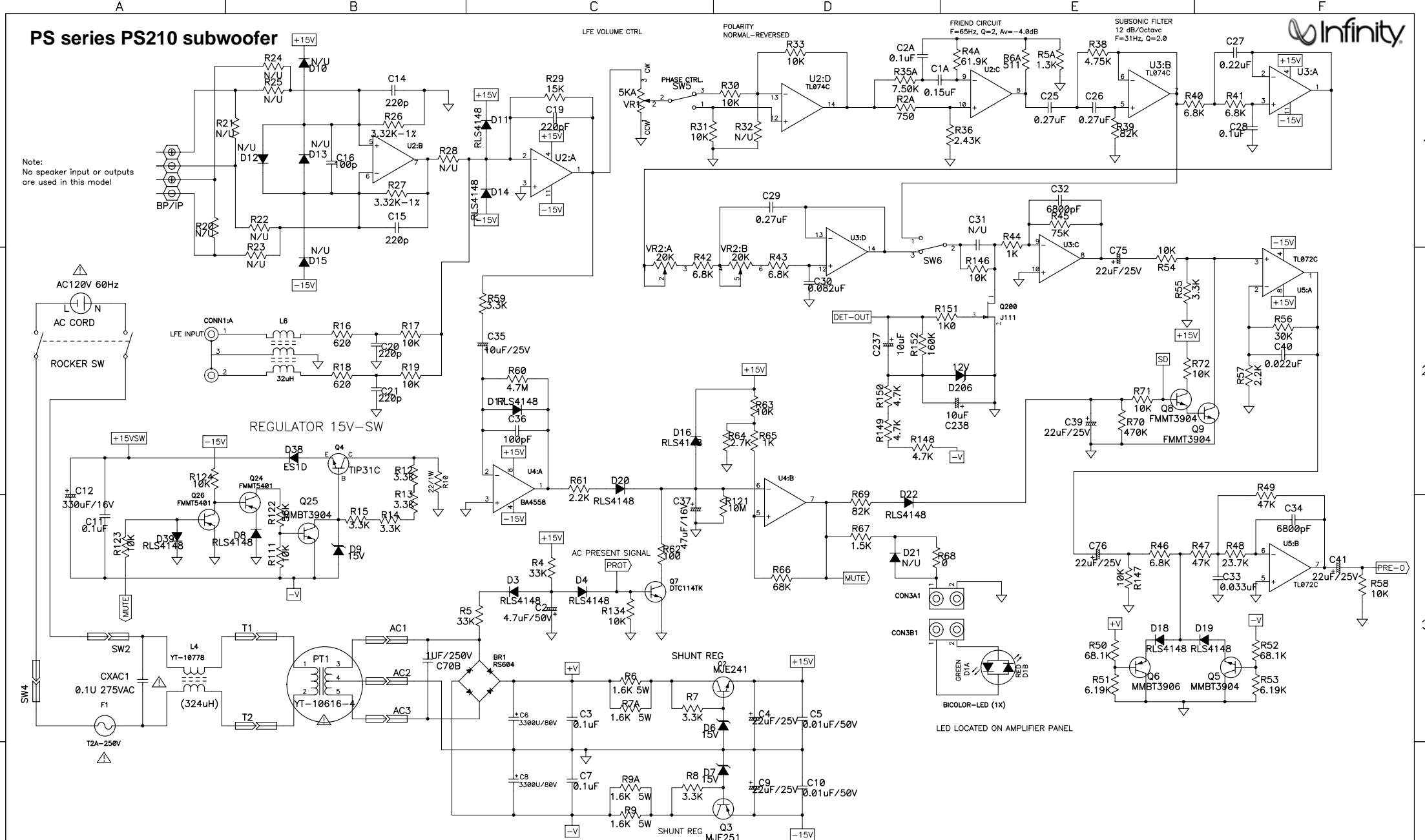

Rev:	Notes:	Date:	Rev:	Notes:	Draw by	Designed by	Checked by	Harman Consumer Group
01	New design	2006/08/17			陳宗志	丁明松	李婉慧	416-0641301
02	Modify R105,108,110,140,35A,4A,2A,5A,36,6A,134,29-33,D21,25	2006/10/04		PS210-120V				
03	Modify C104,R78,PT1	2006/10/27		PS210-120V PRE AMP				
								Issue no: ET-01-21-4256
								Date: 2007/02/15
								Sheet: 15-1 Rev: 03
								Author: AMM/GEORGE

PS series PS210 subwoofer

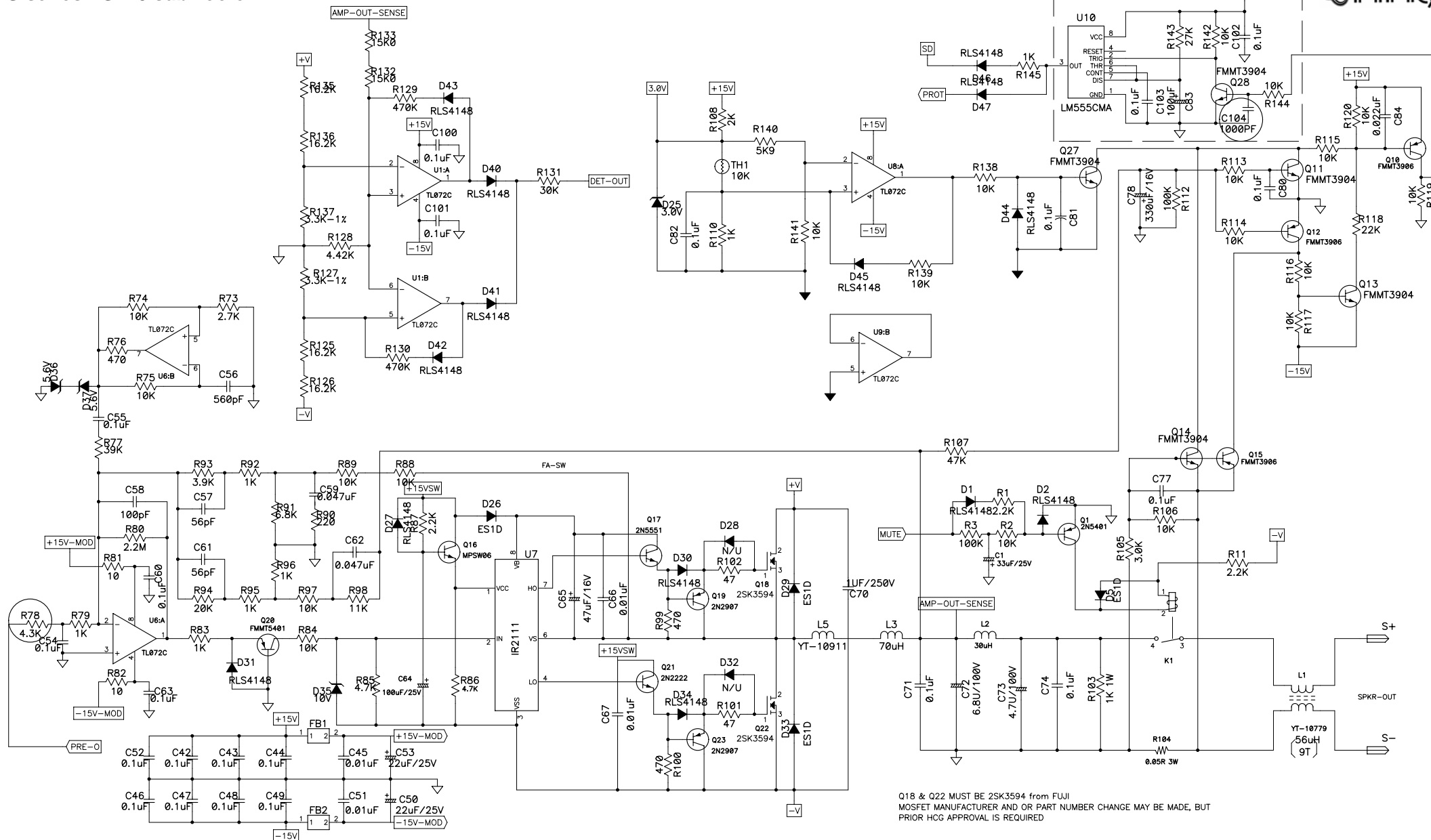

Q18 & Q22 MUST BE 2SK3594 from FUJI MOSFET MANUFACTURER AND OR PART NUMBER CHANGE MAY BE MADE, BUT PRIOR HCG APPROVAL IS REQUIRED

Rev:	Notes:	Date:	Rev:	Notes:	Draw by	Designed by	Checked by	Harman Consumer Group
01	New design	2006/08/17			陳宗志	丁明松	李婉慧	416-0641301
02	Modify R105,108,110,140,35A,4A,2A,5A,36,6A,134,29-33,D21,25	2006/10/04		PS210-120V				
03	Modify C104,R78,PT1	2006/10/27		PS210-120V POWER AMP				
								Issue no: ET-01-21-4256
								Date: 2007/02/15
								Sheet: 15-2 Rev: 03
								Author: AMM/GEORGE