



PS-8

PS Series

SERVICE MANUAL



Infinity Systems Incorporated
250 Crossways Park Dr.
Woodbury, New York 11797

Rev2 10/2006

CONTENTS

BASIC SPECIFICATIONS	1
DETAILED SPECIFICATIONS	2
CONTROLS & CONNECTIONS	3
OPERATION.....	5
UNIT EXPLODED VIEW	6
AMPLIFIER EXPLODED VIEW.....	7
BLOCK DIAGRAM	8
PS-8 TEST SET UP AND PROCEDURE	9
ELECTRICAL PARTS LIST	10
PCB DRAWINGS (serial # ME0683-16316 and below).....	13
PCB DRAWINGS (serial # ME0683-16317 and above)	15
IC – TRANSISTOR PINOUTS	17
SCHEMATIC DIAGRAMS (serial # ME0683-16316 and below).....	18
SCHEMATIC DIAGRAMS (serial # ME0683-16317 and above)	20
SCHEMATIC DIAGRAMS (Rev 2)	22
PACKAGE.....	25

PS-8 SPECIFICATIONS

Frequency Response:	35Hz – 150Hz (± 3 dB)
Maximum Amplifier Output:	100 watts RMS (20Hz – 150Hz with no more than 0.1% THD)
Crossover Frequencies:	50Hz – 150Hz, 24dB/octave, continuously variable
Driver:	8" (203mm) MMD™ DCR = 4.3 Ω
Dimensions	17-1/2" x 10-5/8" x 16-3/4" (H x W x D) (445mm x 270mm x 426mm)
Weight:	33 lb (15kg)

Infinity continually strives to update and improve existing products, as well as create new ones. The specifications and construction details in this and related Infinity publications are therefore subject to change without notice.

INFINITY PRIMUS PS-8 100W Powered Sub/ Plate Amp

LINE VOLTAGE	Yes/No	Hi/Lo Line	Unit	Notes	
US 120VAC/60Hz	Yes	108-132	Vrms	Normal Operation	
Europe 220-240VAC, 50-60Hz	Yes	220-240	Vrms	Normal Operation	
Parameter	Specification	Unit	QA Test Limits	Conditions	Notes
Amp Section					
Type (Class AB, D, other)	AB	AB	n/a		
Load Impedance (speaker)	4	Ohms	n/a	Nominal	
Rated Output Power	100	Watts	95	Single input driven	
THD@ Rated Power	0.5	%	1	22K filter	
THD @ 1 Watt	0.1	%	0.5	22K filter	
DC Offset	10	mV-DC	50	@ Speaker Output	
Damping factor	>100	DF	50	Measured at speaker terminals	Output power 90 Watts THD 0.1 %
Input Sensitivity					
Input Frequency	50	Hz	50	Nominal Freq.	
Line Input (L&R)	171	mVrms	±2dB	To Rated Power	Single input driven, AP Zo=600 Ohms
LFE Input	117	mVrms	±2dB	To Rated Power	LFE input driven only, AP Zo=600 Ohms
Speaker/Hi Level Input	2.4	Vrms	±2dB	To Rated Power	Single input driven
Signal to Noise					
SNR-A-Weighted	100	dBa	85	rel. to rated power	A-Weighting filter
SNR-unweighted	80	dBr	80	rel. to rated power	22K filter
SNR @ 1W-unweighted	60	dBr	60	rel. to 1W Output	22K filter
Residual Noise Floor	1.5	mVrms	2.5	Volume @max, using RMS reading	
Residual Noise Floor	1	mVrms(max)	2	Volume @max, w/ A/P Swept Bandpass Measurement (Line freq.+ harmonics)	
Input Impedance					
Line input L&R, LFE	>10	K ohms	n/a	Nominal	
Speaker/Hi Level Input	4.7	K ohms	n/a	Nominal	
Filters					
Low Pass (fixed or variable)	Variable	--	±2dB		
Subsonic filter (HPF)		Hz	±2dB		
Limiter (yes/no)					
	NO	--	n/a		
Features					
LFE Input, Phase Switch, ATO	YES		functional		
Volume pot Taper (lin/log)	LOG	--	functional		
Input Configuration					
Line In (L,R)	L, R	--	functional		RCA inputs: L, R Summed to Mono
Line level in LFE	LFE		functional		
Spkr/Hi Level In (L,R)	L,R	--	functional		L, R Summed to Mono
Spkr Out: Level out (L,R) Hi Pass Filter					
120 VAC Version	NO			120VAC version is not provided with Spkr. Output connectors	
230 VAC Version	YES		functional	This feature exists in 230VAC Model	Direct by pass from Speaker in
Signal Sensing (ATO)					
Auto-Turn-On (yes/no)	YES	--	functional		
ATO Input Frequency	50	Hz	functional		
ATO Level	2	mV	functional	2mV@50Hz into Line Input w/ 1 ch. driven	
ATO Level Speaker in	35	mV	functional	35mV @ 50 Hz into the speaker input, single input driven.	
ATO Turn-on time	5	ms	functional	Amp connected and AC on, then input signal applied	
Auto Mute/ Turn-OFF Time	10	minutes	functional	T before muting, after signal removed	Auto turn of time (T) must be 5 > T < 15
Power on Delay time					
	3	sec.	functional	AC Power Applied	
Transients/Pops					
ATO Transient	5	mV-peak	10	@ Speaker Outputs	
Turn-on Transient	50	mV-peak	100	@ Speaker Outputs	AC Line cycled from OFF to ON
Turn-off Transient	50	mV-peak	100	@ Speaker Outputs	AC Line cycled from ON to OFF
Efficiency					
Stand-by Input Power	12	Watts	15	@ nom. line voltage	Maximum allowable input power under nominal Input voltage and frequency, HOT or COLD operation.
Power Cons.@rated power	195	Watts	210	@ nom. line voltage	100 Watts @ 4 Ohms
Protection					
Short Circuit Protection	YES	--	functional	Direct short at output	
Thermal Protection	65 deg. C	--	functional	@ 1/8 max unclipped Power	Temperature rise should not exceed 35K rise
DC Offset Protection	YES	--	functional	DC present at Speaker Out leads	Relay or crowbar (for driver/fire protection)
Line Fuse Rating					External fuse with UL/SEMKO rated holder
120 VAC	2.5	Amps		Type-T or Slo Blo	
230 VAC	1.25	Amps		Type-T, Low breaking capacity	
ALL SPECS SHOULD BE MEASURED AT NOMINAL LINE VOLTAGE.					

CONTROLS AND CONNECTIONS

Rear Panel

- 1 Subwoofer-Level Control
- 2 Crossover Adjustment
- 3 Phase Switch
- 4 LFE Input
- 5 Line-Level Inputs
- 6 High-Level Inputs
- 7 Power Switch

Infinity Systems
H A Harman International Company

LEVEL

1

CROSSOVER

2

PHASE

3

LINE LEVEL IN

4

5

HIGH LEVEL INPUT

6

POWER

7

FUSE
T 2.5A L 250V
TYPE

AC-
120V
60HZ
200 Watts

CAUTION
RISK OF ELECTRIC SHOCK - DO NOT OPEN

WARNING: SHOCK HAZARD - DO NOT OPEN
AVIS: RISQUE DE CHOC ELECTRIQUE - NE PAS OUVRIIR

WARNING: TO REDUCE THE RISK OF FIRE OR ELECTRIC SHOCK,
DO NOT EXPOSE THIS APPLIANCE TO RAIN OR MOISTURE!

AVERTISSEMENT: POUR PREVENIR LES RISQUES D'INCENDIE OU
DE CHOC ELECTRIQUE, EVITER D'EXPOSER CET APPAREIL A LA
 PLUIE OU A L'HUMIDITE.

WARNING: FOR CONTINUED PROTECTION AGAINST
RISK OF FIRE, REPLACE ONLY WITH SAME TYPE OF FUSE*
AVERTISSEMENT: UTILISER UN FUSIBLE DE RECHANGE DE MEME TYPE*

PS-8

3

SUBWOOFER CONNECTIONS

CHOOSE THE SUBWOOFER CONNECTION THAT IS MOST SUITABLE FOR YOUR RECEIVER/PROCESSOR

If you have a Dolby® Digital or DTS® receiver/processor with a low-frequency-effects (LFE) or subwoofer output:

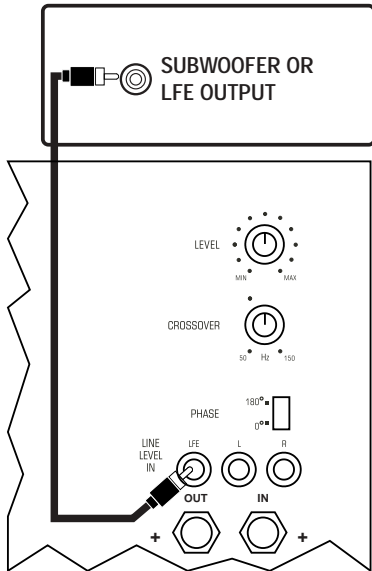

If your receiver/processor does not contain a Dolby Digital or DTS processor but has a subwoofer output:

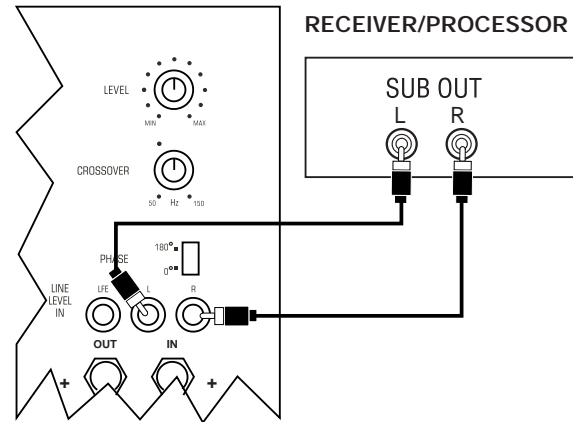

NOTE: Some receivers have one subwoofer output. In that case, it is recommended that you use a Y connector (not included) to maximize performance.

If your receiver/processor does not have subwoofer outputs for the left and right channels or an LFE output, connect speaker wire from your receiver/amplifier to your speakers and subwoofer using two sets of speaker wire:

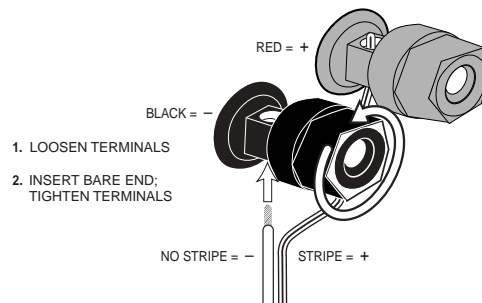
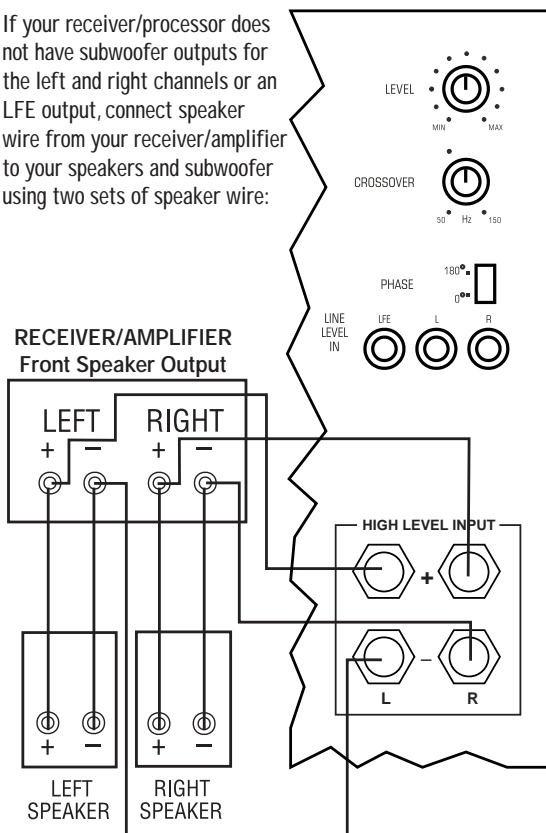

1. LOOSEN TERMINALS
2. INSERT BARE END; TIGHTEN TERMINALS

This figure shows how to connect bare wires to the terminals.

OPERATION

Power On

Plug your subwoofer's AC cord into a wall outlet. Do not use the outlets on the back of the receiver.

Initially set the Subwoofer-Level Control **1** to the "min" position.

Turn on your sub by pressing the Power Switch **7** on the rear panel.

Turn on your entire audio system and start a CD or movie sound-track at a moderate level.

Auto On/Standby

With the Power Switch **7** in the ON position, the LED on the front panel will remain lit in red or green to indicate the On/Standby mode of the subwoofer.

RED = STANDBY (No signal detected, Amp Off)

GREEN = ON (Signal detected, Amp On)

The subwoofer will automatically enter the Standby mode after approximately 10 minutes when no signal is detected from your system. The subwoofer will then power ON instantly when a signal is detected. During periods of normal use, the Power Switch **7** can be left on. You may turn off the Power Switch **7** for extended periods of nonoperation, e.g., when you are away on vacation.

Adjust Level

Turn your Subwoofer-Level Control **1** up to the "5" position (halfway). If no sound emanates from the subwoofer, check the AC-line cord and input cables. Are the connectors on the cables making proper contact? Is the AC plug connected to a "live" receptacle? Has the Power Switch **7** been pressed to the "On" position? Once you have confirmed that the subwoofer is active, proceed by playing a CD, record or cassette. Use a selection that has ample bass information.

Set the overall volume control of the preamplifier or stereo to a comfortable level. Adjust the Subwoofer-Level Control **1** until you obtain a pleasing blend of bass. Bass response should not overpower the room but rather be adjusted so there is a harmonious blend across the entire musical range. Many users have a tendency to set the subwoofer volume too loud, adhering to the belief that a subwoofer is there to produce lots of bass. This is not entirely true. A subwoofer is there to enhance bass, extending the response of the entire system so the bass can be felt as well as heard. However, overall balance must be maintained or the music will not sound natural. An experienced listener will set the volume of the subwoofer so its impact on bass response is always there but never obtrusive.

Phase Control

The Phase Switch **3** determines whether the subwoofer speaker's piston-like action moves in and out with the main speakers, 0°, or opposite the main speakers, 180°. Proper phase adjustment depends on several variables such as room size, subwoofer placement and listener position. Adjust the phase switch to maximize bass output at the listening position.

Crossover Adjustments

The Crossover Adjustment control **2** determines the highest frequency at which the subwoofer reproduces sounds. If your main speakers can comfortably reproduce some low-frequency sounds, set this control to a lower frequency setting, between 50Hz and 100Hz. This will concentrate the subwoofer's efforts on the ultradeep bass sounds required by today's films and music. If you are using smaller bookshelf speakers that do not extend to the lower bass frequencies, set the Crossover Adjustment control to a higher setting, between 120Hz and 150Hz.

NOTE: This control will have no effect if the LFE Input **4** is used. If you have a Dolby Digital or DTS processor/receiver, the Low-Pass Frequency is set by the processor/receiver. Consult your owner's manual to learn how to view or change this setting.

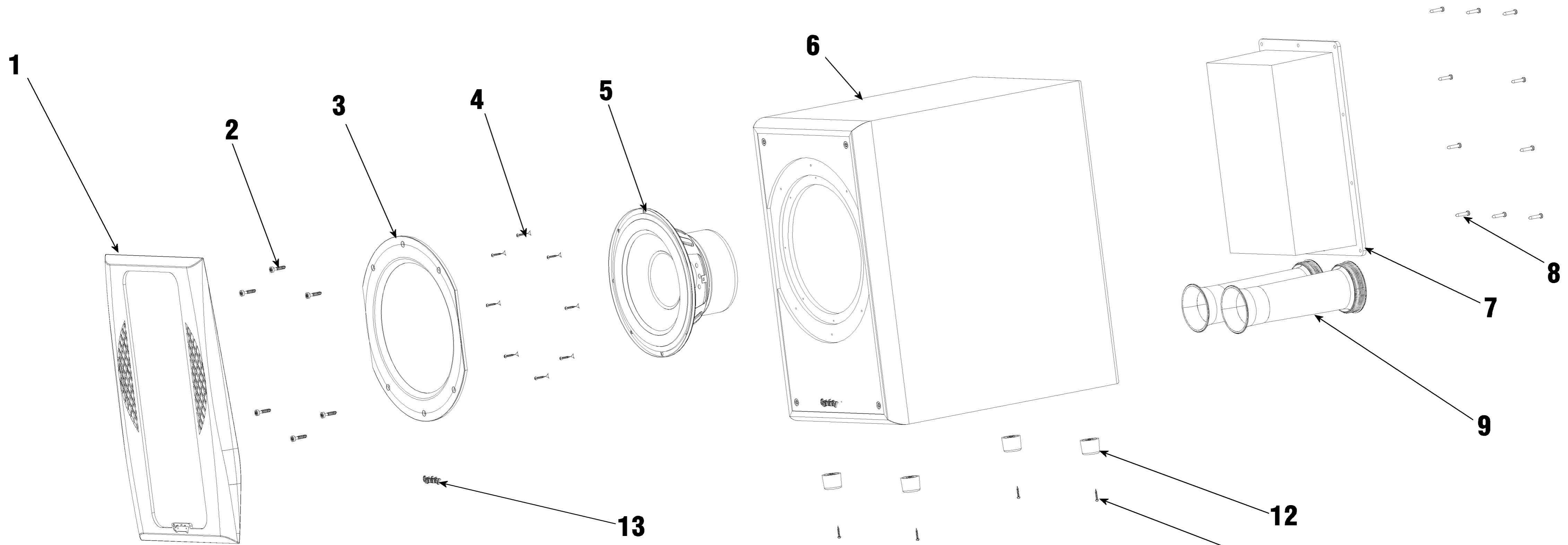

Ref#	Description	Part Number	Qty
1	Grille	244-080-0025	1
2	Screw (Trim Ring)	352-DM04525D597	6
3	Woofer Trim Ring	213-080-00488	1
4	Screw (Woofer)	352-FM04014D609	8
5	8" Woofer	20PR10DAG-FW04	1
6	PS-8 Cabinet	Not for sale	1
7	PS-8 Amplifier	Not for sale	1
8	Screw (Amplifier)	352-AM04020D210	10
9	Port Tube	249-HIPS-01003	2
10	Foot Pad	320-RUB-00199	4
11	Screw (Foot)	352-CM04025D604	4
12	Feet (Main)	320-ABS-00195	4
13	Logo	316-ABS-00532	1

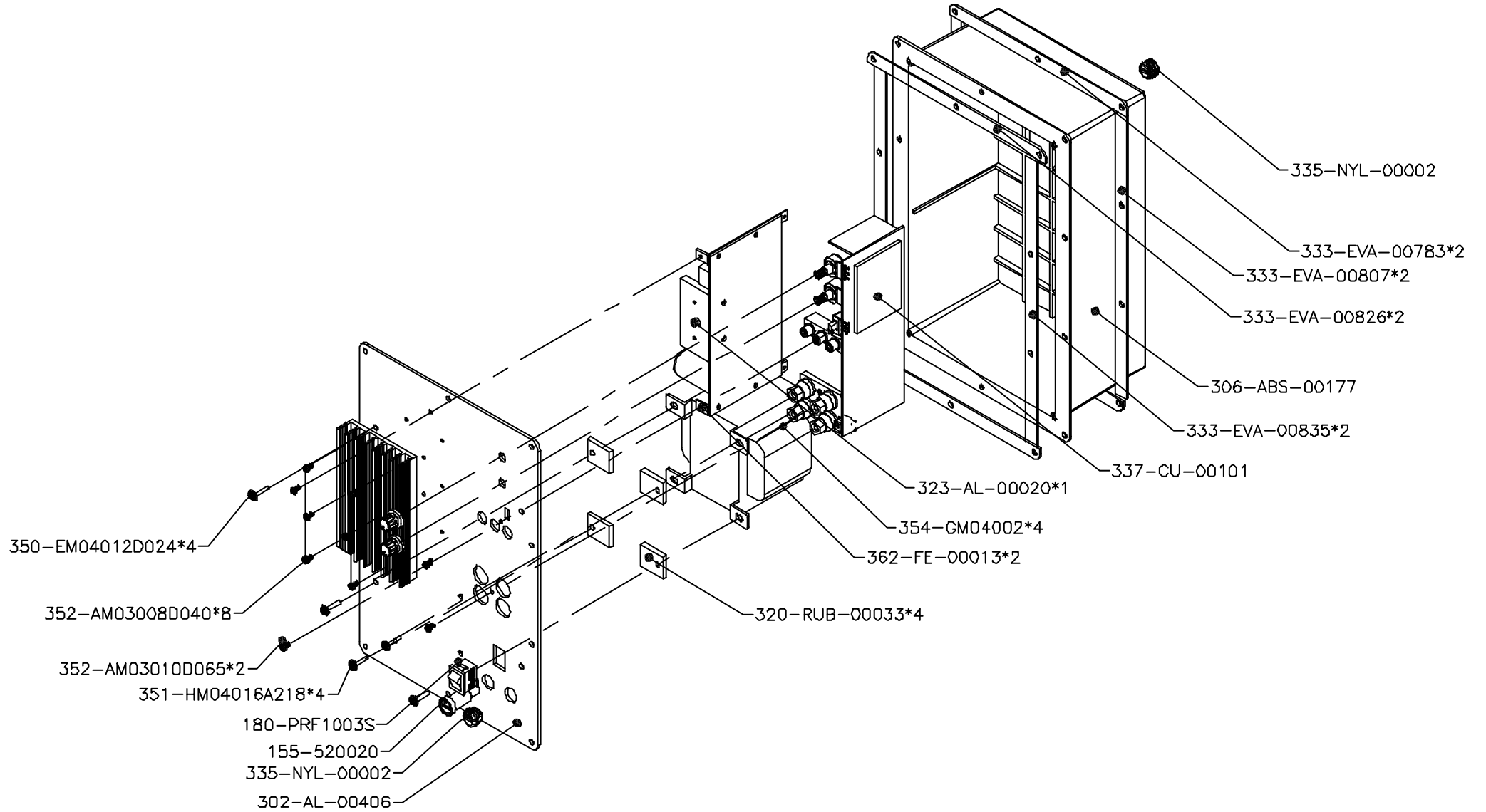

PS-8 U/E BLOCK DIAGRAM

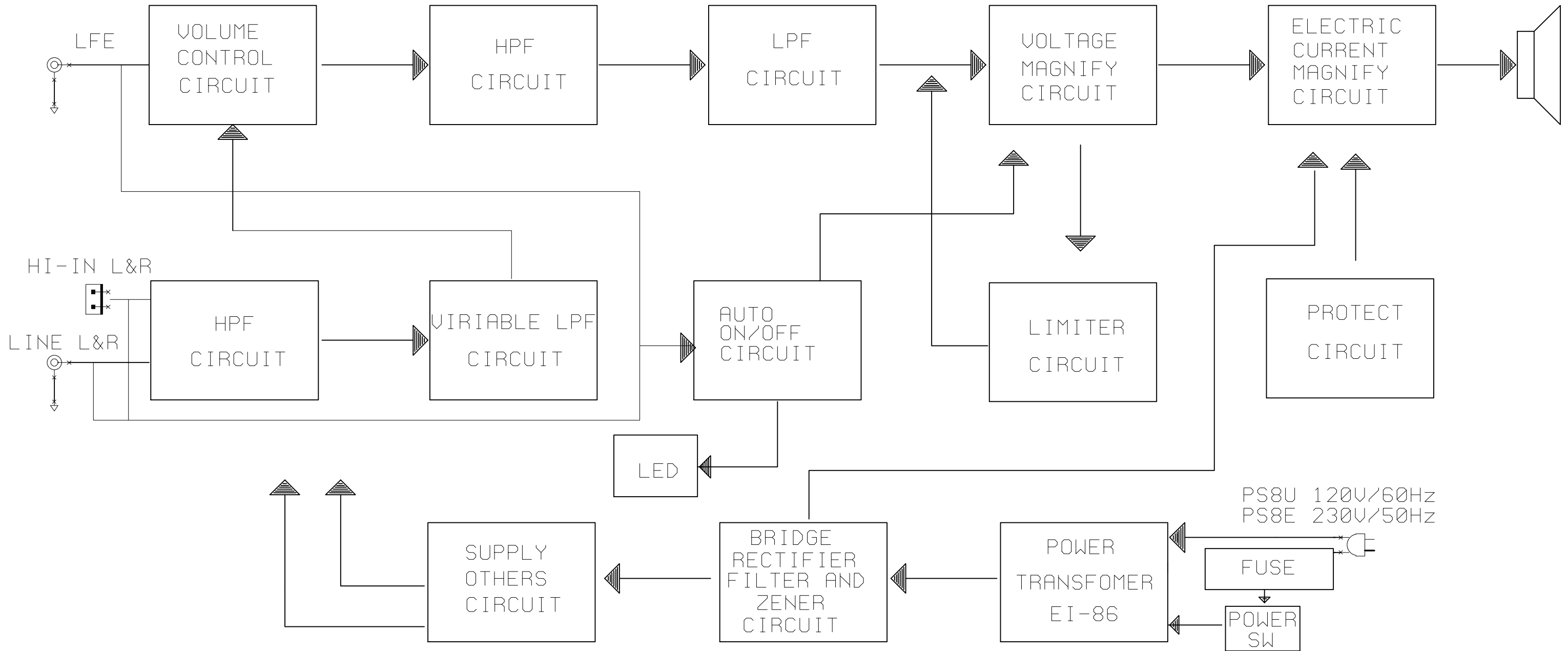

PS8U 120V/60Hz
PS8E 230V/50Hz

PS-8 Test Set Up and Procedure

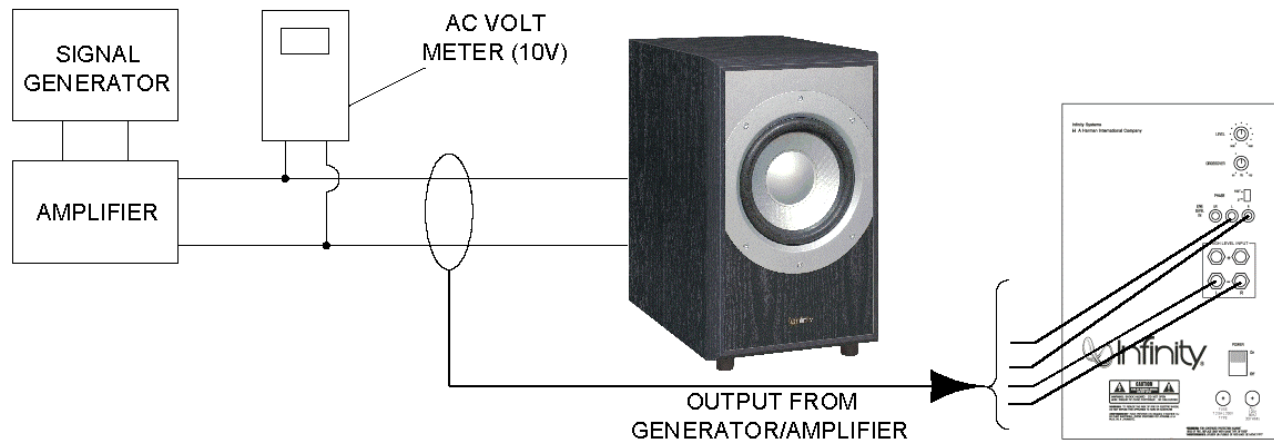

SYSTEM AURAL SWEEP TEST

Equipment needed:

- Function/signal generator/sweep generator
- Integrated Amplifier
- Multimeter
- Speaker cables

General Unit Function (UUT = Unit Under Test)

Switches/knobs on the amplifier faceplate:

Low Pass Frequency Adjust full CW (150Hz)

Phase switch – either position

1. From the signal generator, Connect both right and left line level inputs (RCA) – not the LFE jack - to signal generator and UUT. Use Y-cable if necessary from mono source.
2. On the amplifier, turn the LEVEL control full Counterclockwise (Min).
3. Turn on generator, adjust to **75mV, 50 Hz**.
4. Plug in UUT; turn the power switch ON. Turn LEVEL control full Clockwise (Max).
5. LED should now be Green; immediate bass response should be heard and felt from rear port tube opening.
6. Turn off generator, turn LEVEL control fully Counterclockwise (Min), disconnect RCA cable.
7. Connect one pair of speaker cables to one set of High Level input terminals on UUT. Cables should be connected to an integrated amplifier fed by the signal generator.
8. Turn on generator and adjust so that speaker level input at the amplifier is **1.5V, 50 Hz**. Turn LEVEL control full Clockwise (Max).
9. Green LED should light; immediate bass response should be heard and felt from the port tube opening.

Sweep Function

1. Follow steps 7-10 above, using a sweep generator as a signal source.
2. Sweep generator from 20Hz to 1kHz. Listen to the cabinet and drivers for any rattles, clicks, buzzes or any other noises. If any unusual noises are heard, remove woofer and test.

Driver Function (Woofer)

1. Remove woofer from cabinet; detach + and - wire clips.
2. Check DC resistance of woofer; it should be **4.5 ohms \pm 10%**.
3. Connect a pair of speaker cables to driver terminals. Cables should be connected to an integrated amplifier fed by a signal generator. Turn on generator and adjust so that speaker level output is **5.0V**.
4. Sweep generator from 20Hz to 1kHz. Listen to driver for any rubbing, buzzing, or other unusual noises.

PS-8 Electrical Parts List (See addendum for serial # ME0683-16317 and above)			
Part number	Description	Reference Designator	Qty
<i>Resistors</i>			
110-14122j26	Resistor 1.2K 1/4W ±5% CF 26mm	R270	1
110-10821jk2	Resistor 820Ω 1W ±5% 10mm	R132	1
110-122r2j15	Resistor 2.2Ω 1/2W ±5% 15mm	R127	1
113-50r10j10	Cement resistor 0.1Ω 5W ±5%	R121,122	2
114-03302m0	Semi-fixed resistor 3K 0.3W ±20%	R138	1
115-h203b208	Variable resistor B20K FREQUENCY	VR202	1
115-h503a104	Variable resistor D16 50K/1 A LEVEL	VR201	1
110-20331jk2	Resistor 330Ω 2W ±5% 5mm	R146	1
110-12472j52	Resistor 4.7K 1/2W ±5% CF 52mm	R201,R202	2
110-14681j26	Resistor 680Ω 1/4W ±5% CF 26mm	R148,R151	2
110-16101j26	Resistor 100Ω 1/6W ±5% CF 26mm	R120	1
110-16102j26	Resistor 1K 1/6W ±5% CF 26mm	R124,213,214,215,254	5
110-16103j26	Resistor 10K 1/6W ±5% CF 26mm	R134,209,212,216,217,220,221,222,225,226,228,232,235,240,2	15
110-16104j26	Resistor 100K 1/6W ±5% CF 26mm	R231,266	2
110-16105j26	Resistor 1M 1/6W ±5% CF 26mm	R143,259,	2
110-16123j26	Resistor 12K 1/6W ±5% CF 26mm	R135,139,227	3
110-16151j26	Resistor 150Ω 1/6W ±5% CF 26mm	R253	1
110-16152j26	Resistor 1.5K 1/6W ±5% CF 26mm	R103,123,136,137,141,142	6
110-16153j26	Resistor 15K 1/6W ±5% CF 26mm	R118,145,152,154	4
110-16154j26	Resistor 150K 1/6W ±5% CF 26mm	R131,203,204,205,206,252	6
110-16181j26	Resistor 180Ω 1/6W ±5% CF 26mm	R111,114	2
110-16183j26	Resistor 18K 1/6W ±5% CF 26mm	R262	1
110-16205j26	Resistor 2M 1/6W ±5% CF 26mm	R257	1
110-16223j26	Resistor 22K 1/6W ±5% CF 26mm	R128,129,133,238,247,250,255,233	8
110-16273j26	Resistor 27K 1/6W ±5% CF 26mm	R237	1
110-16332j26	Resistor 3.3K 1/6W ±5% CF 26mm	R106,R107,144	3
110-16392j26	Resistor 3.9K 1/6W ±5% CF 26mm	R105,108	2
110-16393j26	Resistor 39K 1/6W ±5% CF 26mm	R126	1
110-16470j26	Resistor 47Ω 1/6W ±5% CF 26mm	R112,113,115,116	4
110-16471j26	Resistor 470Ω 1/6W ±5% CF 26mm	R140	1
110-16472j26	Resistor 4.7K 1/6W ±5% CF 26mm	R110,125,130,200,207,258,260	7
110-16473j26	Resistor 47K 1/6W ±5% CF 26mm	R101,219,251	3
110-16512j26	Resistor 5.1K 1/6W ±5% CF 26mm	R210,211,229,230	4
110-16563j26	Resistor 56K 1/6W ±5% CF 26mm	R104	1
110-14472j26	Resistor 4.7K 1/4W ±5% CF 26mm	R147,150	2
110-16682j26	Resistor 6.8K 1/6W ±5% CF 26mm	R109	1
110-16333j26	Resistor 33K 1/6W ±5% CF 26mm	R249	1
110-16182j26	Resistor 1.8K 1/6W ±5% CF 26mm	R153	1
110-16103j26	Resistor 10K 1/6W ±5% CF 26mm	R301,303,304,308,309,314,340,344	8
110-16223j26	Resistor 22K 1/6W ±5% CF 26mm	R310,312	2
110-16273j26	Resistor 27K 1/6W ±5% CF 26mm	R341	1
110-16472j26	Resistor 4.7K 1/6W ±5% CF 26mm	R342,43	2
110-16474j26	Resistor 470K 1/6W ±5% CF 26mm	R307	1
110-16751j26	Resistor 750Ω 1/6W ±5% CF 26mm	R311,313	2
110-20331jk3	Resistor 330Ω 2W ±5%	R149	1
110-16183j26	Resistor 18K 1/6W ±5% CF 26mm	R302	1
110-16560j26	Resistor 56Ω 1/6W ±5% CF 26mm	R117	1
110-16562j26	Resistor 5.6K 1/6W ±5% CF 26mm	R224,234	2
116-164531f26	Resistor 4.53K 1/6W ±1% MF26mm	R223	1

Part number	Description	Reference Designator	Qty
<i>Semiconductors</i>			
192-027c1815gr	Transistor 2SC1815GR NPN	Q102,111,112,113,118,201,206,207	8
192-028a1015gr	Transistor 2SA1015GR PNP	Q114,116	2
192-1672n5551	Transistor 2N5551 NPN	Q103,109	2
192-1682n5401	Transistor 2N5401 PNP	Q104,110	2
197-131n4148	Diode 1N4148 26mm	D101,103,105,108	4
199-15000335	Zener diode 3.3V 1/2W 52mm	D102,213	2
199-15000625	Zener diode 6.2V 1/2W 52mm	D106,107	2
199-15001605	Zener diode 16V 1/2W 52mm	D109	1
192-027c1815gr	Transistor 2SC1815GR NPN	Q301,302	2
197-131n4148	Diode 1N4148 26mm	D301,302	2
190-16t1074cn	I.C TL074CN ST QUAD OP-AMP	U301	1
190-06m4558d	I.C. OPA 4558D DUAL OP-AMP	U101,203	2
190-16t1074cn	I.C TL074CN ST QUAD OP-AMP	U201,202	2
192-991d669a	Transistor HI-SINCERITY HSD669A NPN	Q106	1
192-992b649t	Transistor HSB649T PNP	Q105	1
192-021c1815gr	Transistor 2SC1815GR NPN	Q101,115	2
192-021tip35c	Transistor TIP35C NPN	Q107	1
192-022tip36c	Transistor TIP36C PNP	Q108	1
192-201d882y	Transistor KSD882Y NPN	Q117	1
192-202b772y	Transistor KSB772Y PNP	Q119	1
197-00kb1405	Bridge rectifier 4A 500V KBL405	D110	1
197-101n4002	Diode 1N4002	D104	1
197-131n4148	Diode 1N4148 26mm	D117,118	2
197-131n4148	Diode 1N4148 26mm	D116	1
195-10204hgw	LED 204HGW 3□		1
190-16t1074cn	I.C TL074CN ST QUAD OP-AMP	U201,202	2
<i>Capacitors</i>			
132-104kb70	CAPACITOR 0.1uF 275v+/-10%	POWER SW	1
129-a474j633	Plastic cap. 0.47U 63V ±5% MSC	C221,222	2
135-4688m50	Electronic cap. 6800U/50V	C121,122	2
135-3107m16	Electronic cap. 100uF 16V ±20%	C110	1
132-223ja03	Mylar capacitor 0.022uF 100V ±5%	C123,127	2
130-2b102k503	Disc capacitor 1000P 50V ±10%	C116	1
130-2b221k503	Disc capacitor 220P 50V ±10%	C204,205,207,208,210,211,212,214,220,230,200,249	12
130-2f104z503	Disc capacitor 0.1U 50V +80/-20%	C108,113,115,119,232,242,244,245,246,252,254	11
130-3f473m503	Disc capacitor 0.047U 50V ±20%	C106	1
130-sl470k503	Disc capacitor 47P 50V ±10%	C229	1
132-103j503	Mylar capacitor 0.01U 50V ±5%	C223,224	2
132-104j503	Mylar capacitor 0.1U 50V ±5%	C107,215,217	3
132-223ja03	Mylar capacitor 0.022uF 100V ±5%	C124,125,126,128	4
135-3105m50	Electronic cap. 1U 50V ±20%	C105,112,228	3
135-3106m50	Electronic cap. 10uF 50V ±20%	C201,202,206,213,219,231,241,243,251,253	10
135-3107m16	Electronic cap. 100uF 16V ±20%	C109,117,120,233,234	5
135-3226m50	Electronic cap. 22U 50V ±20%	C114,118,225	3
135-3227m10	Electronic cap. 220U 10V ±20%	C129,130	2
135-3227m16	Electronic cap. 220U 16V ±20%	C111	1
135-3476m25	Electronic cap. 47U 25V ±20%	C103	1
129-a224j633	Plastic cap. 0.22uF 63V ±5% MSC	C218	1
129-a564j633	Plastic cap. 0.56uF 63V ±5%	C216	1
130-2f104z503	Disc capcitor 0.1U 50V +80/-20%	C305,306	2
132-103j503	Mylar capcitor 0.01U 50V ±5%	C302,303	2
135-3226m50	Electronic cap. 22U 50V ±20%	C301,340	2
135-3476m25	Electronic cap. 47U 25V ±20%	C304	1

Part number	Description	Reference Designator	Qty
<i>Miscellaneous</i>			
193-3m2520	Piezo TO-3P 25x20mm	Q107,108	2
162-50259201	WIRE ASS'Y 2 PIN 250mm red/white	LED1	1
351-AM03014A094	Screw M3*14		
352-AM03008D040	Screw □3*8		
361-FE-00051	Transistor 14.2*8.0*5.2t=1.6mm		
323-AL-00020	HEAT SINK 65*32*31		
361-NYL-00054	Transistor SW06002		
174-2psz406g1	JACK S-8071	JK203	1
162-80098201	Single line wire 90mm grey 28AWG	SW301	1
162-50289001	Cable ass'y 280mm AWG26WHT		
175-9f40hr2	Contacto 40pin pitch=2.54mm	P301	1
171-udhss124d	Relay 5A 24V UDH-SS124D	RY101	1
174-0300390g	JACK JE0300390G	JK202	1
175-1c07v01	Contacto 7PIN PITCH=2.5mm	P101	1
175-1d02v01	Contacto 2PIN PITCH=3.96mm	P102	1
175-1d03v01	Contacto 3 PIN PITCH=3.96mmJST-VH	P103	1
180-tms7210v	SWITCH SLIDE 6PIN MS7210V	SW201	1
150-e8604107	TRANSFORMER EI-86 60Hz 120v		
152-u602015	PWR CABLE/W/ POLARITY SVT FT-26FT		
154-u25006t0	FUSE 2.5A 250V 20MM	FS101	1
155-520020	FUSE HOLDER R3-11		
162-10082007	WIRE RED 18AWG 80MM 8MM#1015		
162-50652003	WRIE 650MM RED=205# 0.5TBLK=110# 0.5t		
176-wjcel	CLOSE TERMINAL CE-1		
180-prf1003S	POWER SWITCHER ROCK RF-1003-BB2-OHA	SW101	1
350-EM04012D024	4□*12 SCREW		
351-HM04016A218	M4*16 SCREW		
351-AM03008A079	M3*8 SCREW		
352-AM03010D065	□3*10 SCREW P		
352-AM03008D040	□3*8 SCREW B		
354-GM04002	M4 SCREW CAP WITH DENT GASKET		
302-AL-00406	AL BACK BOARD 300*200*2.5t		
362-FE-00013	PCB BRACKET L TYPE T=1.6MM		
323-AL-00106	HEAT SINK 117.5*71.5*25 POLARITY		
311-ABS-00028	PLASTIC KNOB 46077-W, SOFT PVC		
306-ABS-00177	BACK BOARD 198*298*102MM		
333-EVA-00783	GASKET W 198*12*2.0T		
333-EVA-00807	GASKET L 274*12*2.0T		
333-EVA-00826	GASKET W 274*12*1.0T		
333-EVA-00835	GASKET L 274*12*1.0T		
320-RUB-00033	RUBBER GASKET 25*21*4T		
123-14j70d	FERRITE CORE U-16.3*8.2*13(J70)+CASE		
337-CU-00101	BRASS BAR 65L*50W		
333-EVA-00761	GASKET 18*9*2T		
ADDENDUM: Changes to serial # ME0683-16317 and above			
		Comment included	
135-3225m50	Electronic cap. 2.2uF 50V	C219 (Change in Value)	1
110-16562j26	Resistor 11.3k 1%	R224 (Now attached from U301 pin 10 or 13 to GRND)	1
116-164991f26	Resistor 4.99K 1%	R234 (Change in Value)	1
110-16333j26	Resistor 33K	R305 (New - not previously installed)	1

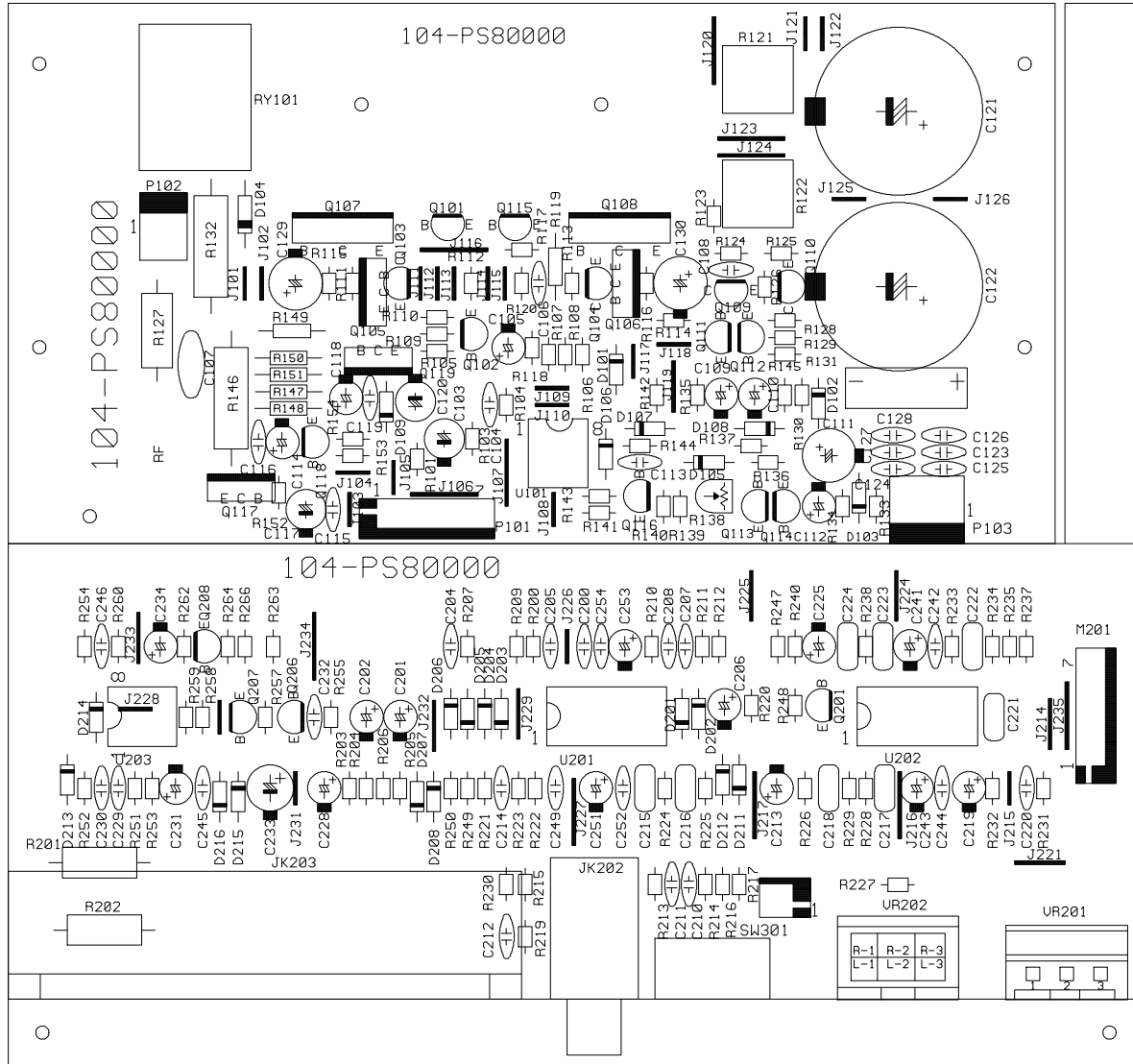

DRAWN.	FILENAME :	REVISION:
	MODEL NO.	1
	MATERIAL :	2
	LAYER SILK SCREEN	3
DSGN.		
APUD.		

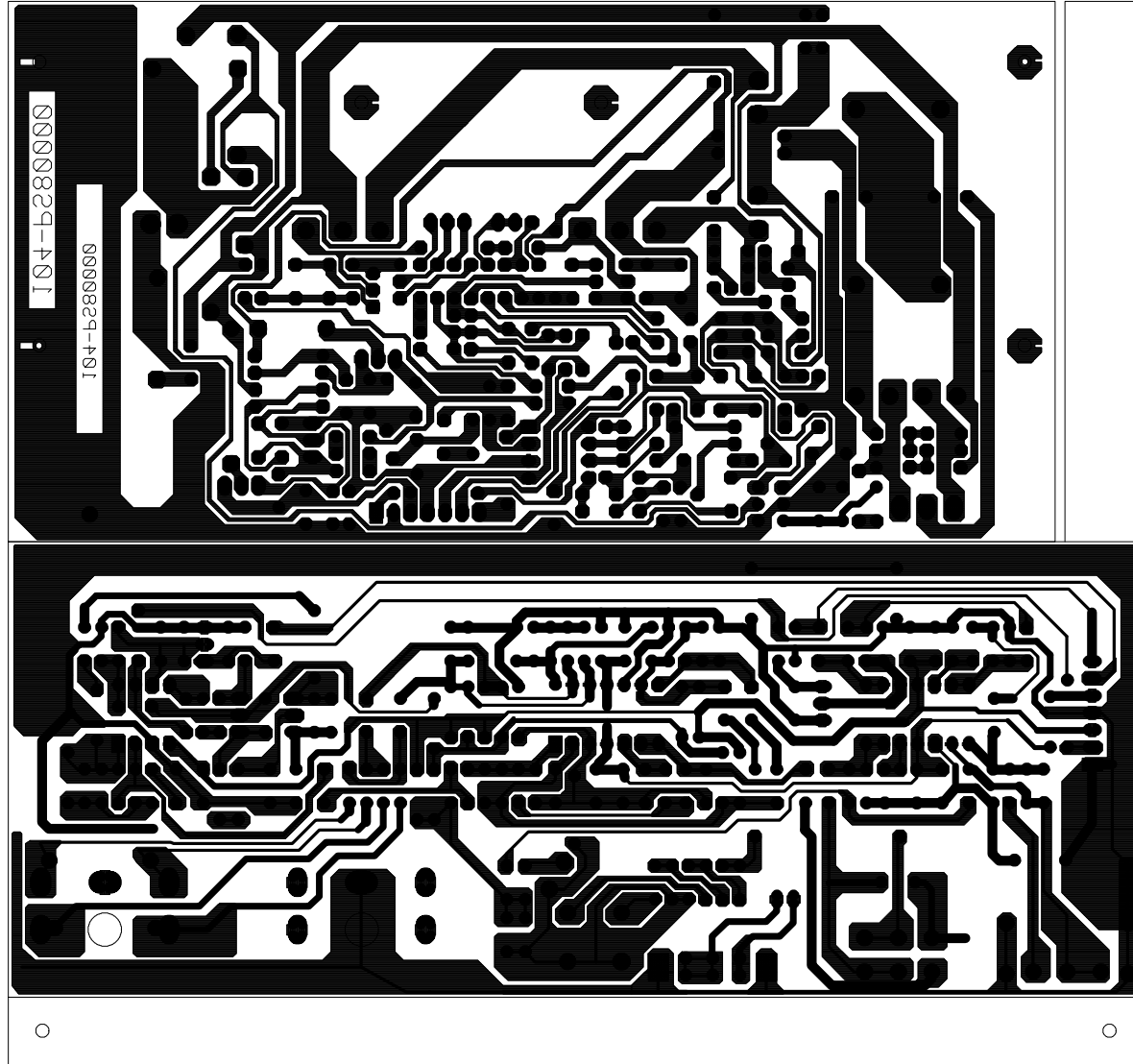

			FILENAME :	REVISION:
DRAW.			MODEL NO.	1
	DSGN.		MATERIAL :	2
		APUD.	LAYER	SOLDER PATTERN 3

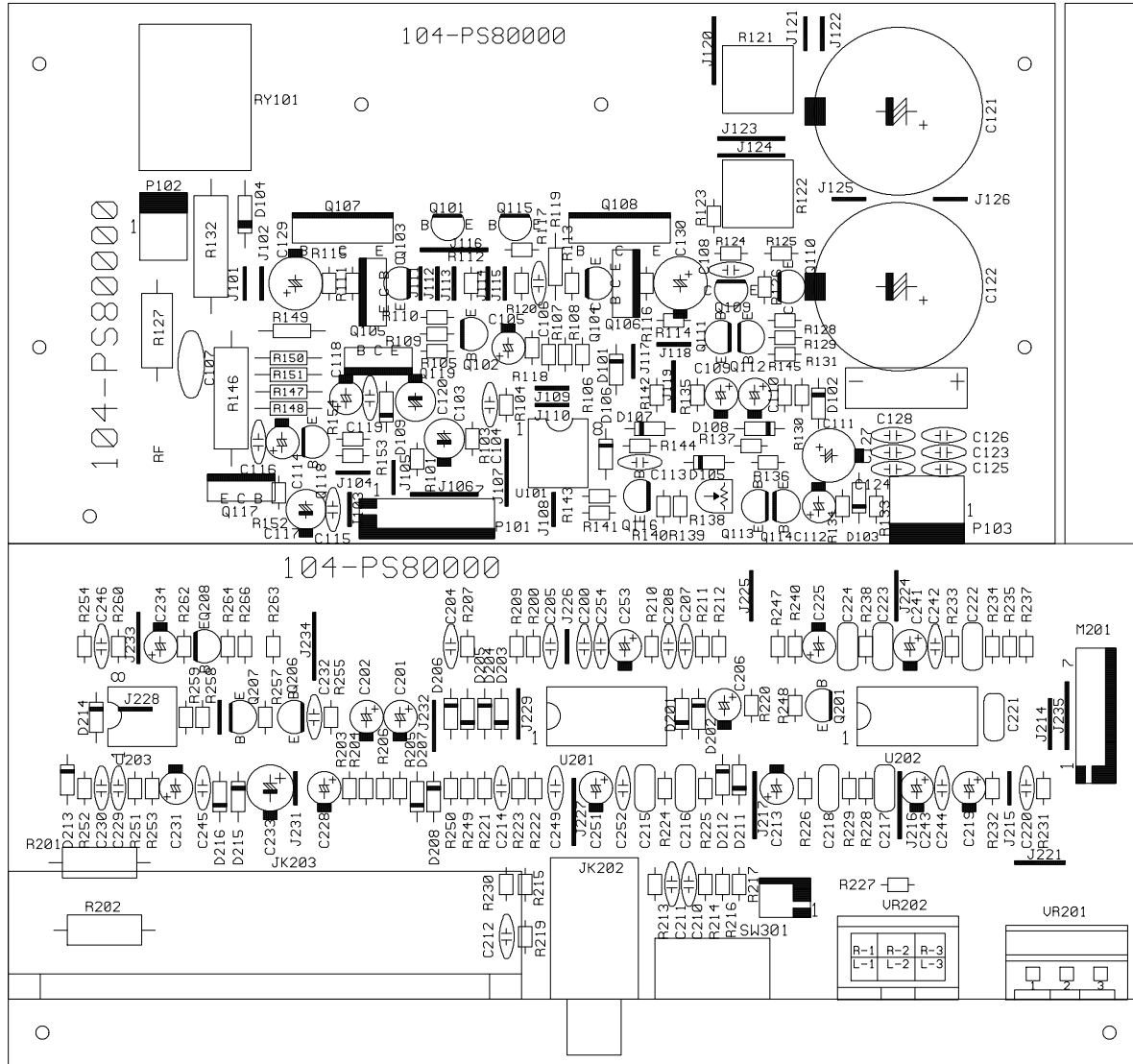

DRAWN.	FILENAME :	REVISION:
	MODEL NO.	1
	MATERIAL :	2
	LAYER SILK SCREEN	3
DSGN.		
APUD.		

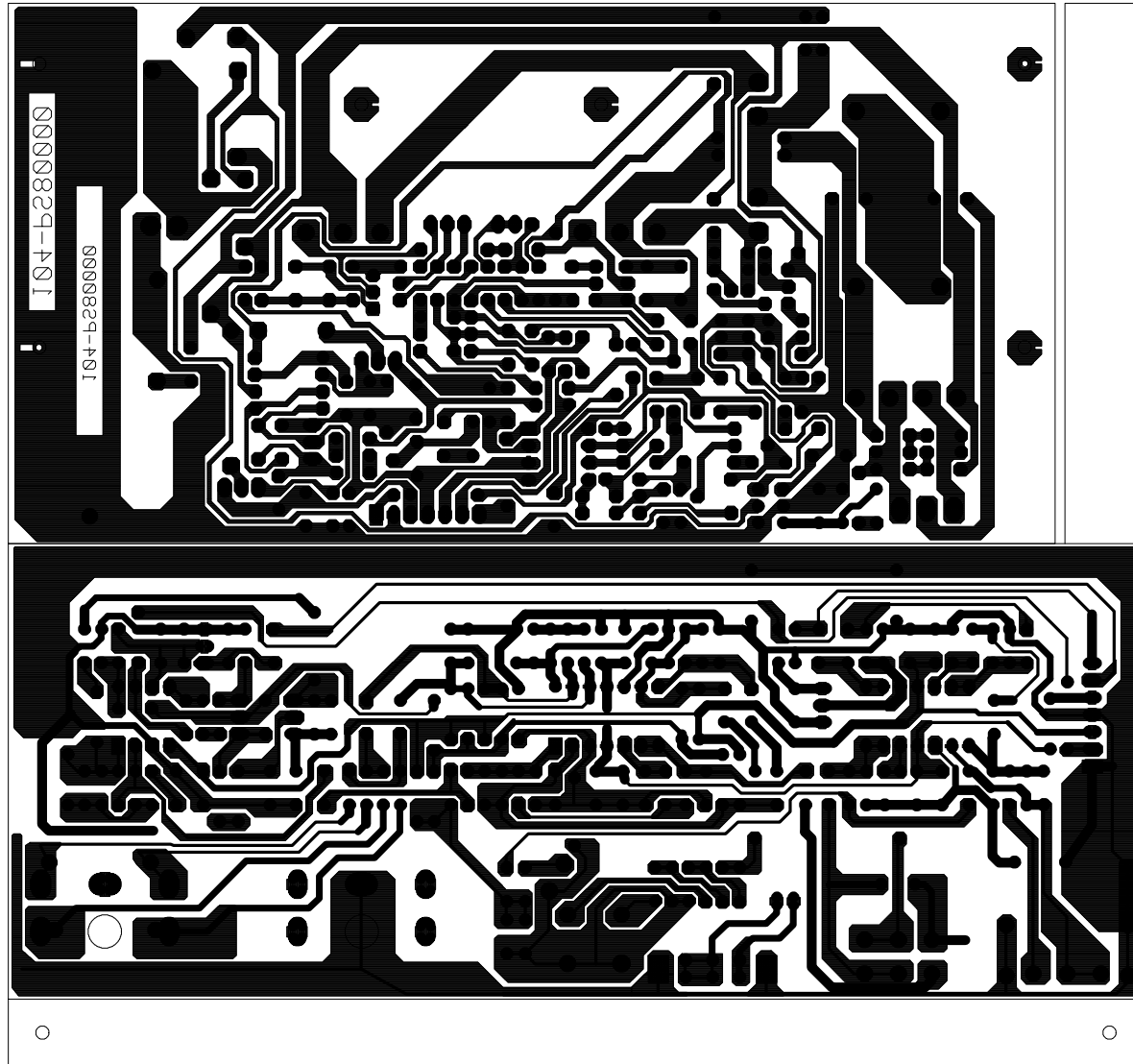

			FILENAME :	REVISION:
DRAW.			MODEL NO.	1
DSGN.			MATERIAL :	2
APUD.			LAYER	3
			SOLDER PATTERN	

Integrated Circuit Diagrams

4558 Dual Op Amp
U101,203

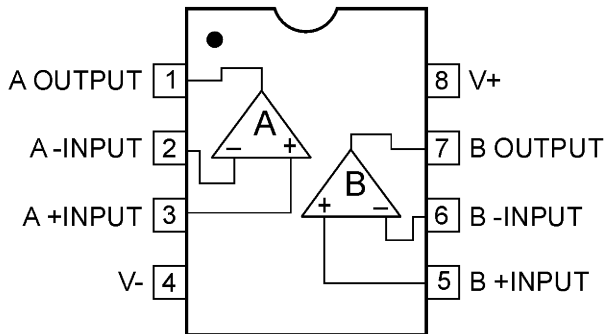

OPAMP, QUAD 14P DIL TL074
U201, 202, 301

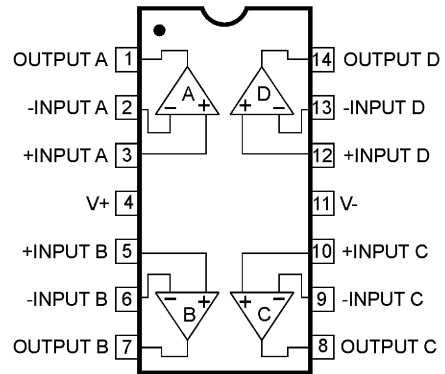

2SA1015
Q114,116

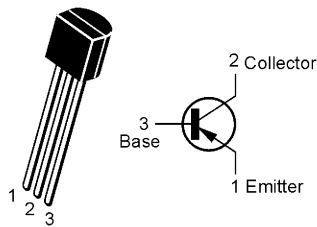

2SC1815
Q101,102,111,112,113,115,118,201,
206,207,301,302

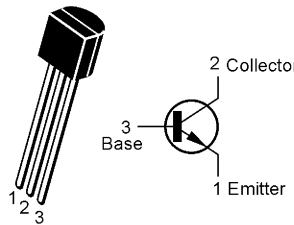

TIP35C, TIP36C
Q107,108

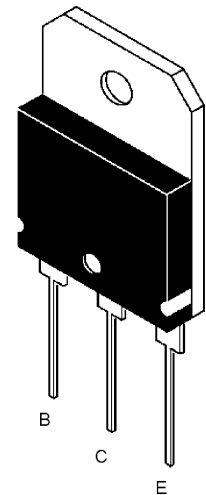

HSD669, HSB649,
KSD882, KSB772

Q105,106,117,119

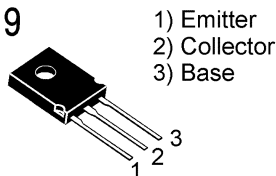

2N5401

Q104, 110

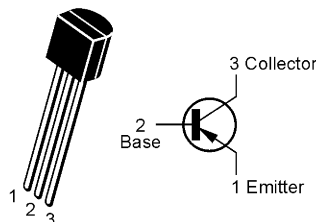

2N5551

Q103, 109

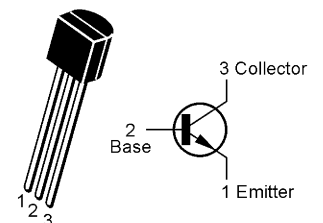

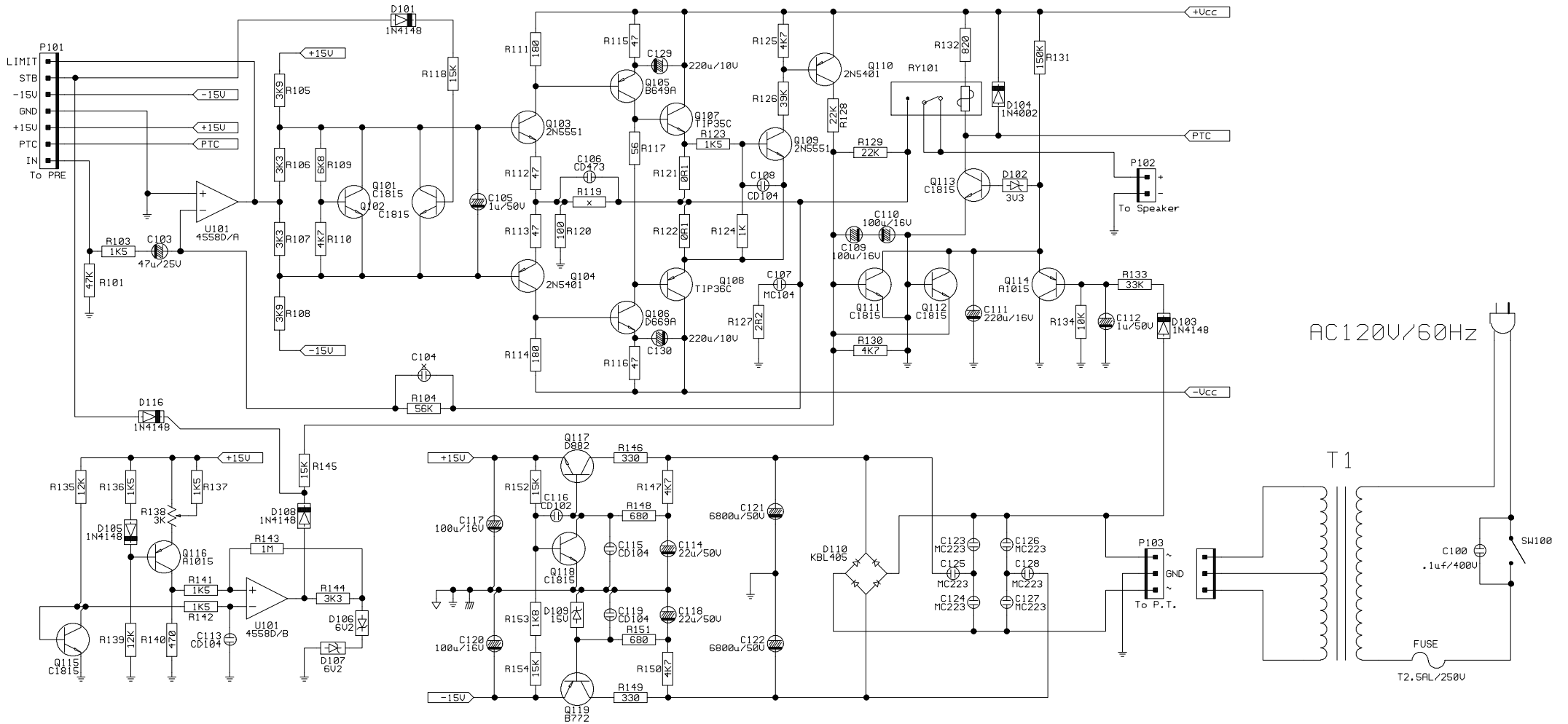

Infinity primus ps-8

DRAW.	DSGN.	APVD.	FILENAME : PS8U.SCH	REVISION : 2
			MODEL NO. 010-7510-00326	1
			DWN BY : C.S.WANG	2
			DATE : 2003-4-16	3

PS-8 (serial # ME0683-16317 and above)

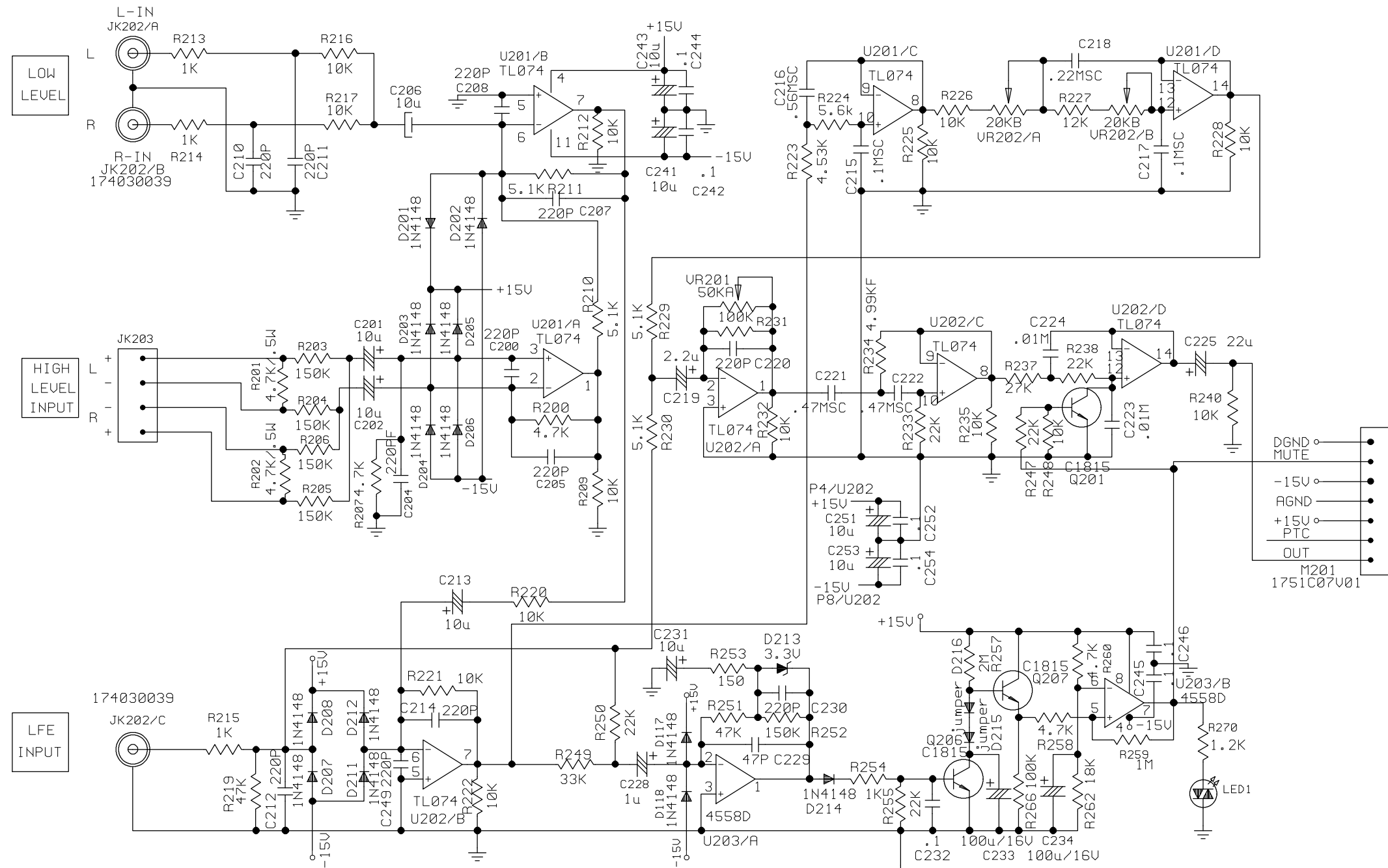

Infinity primus ps-8
120U

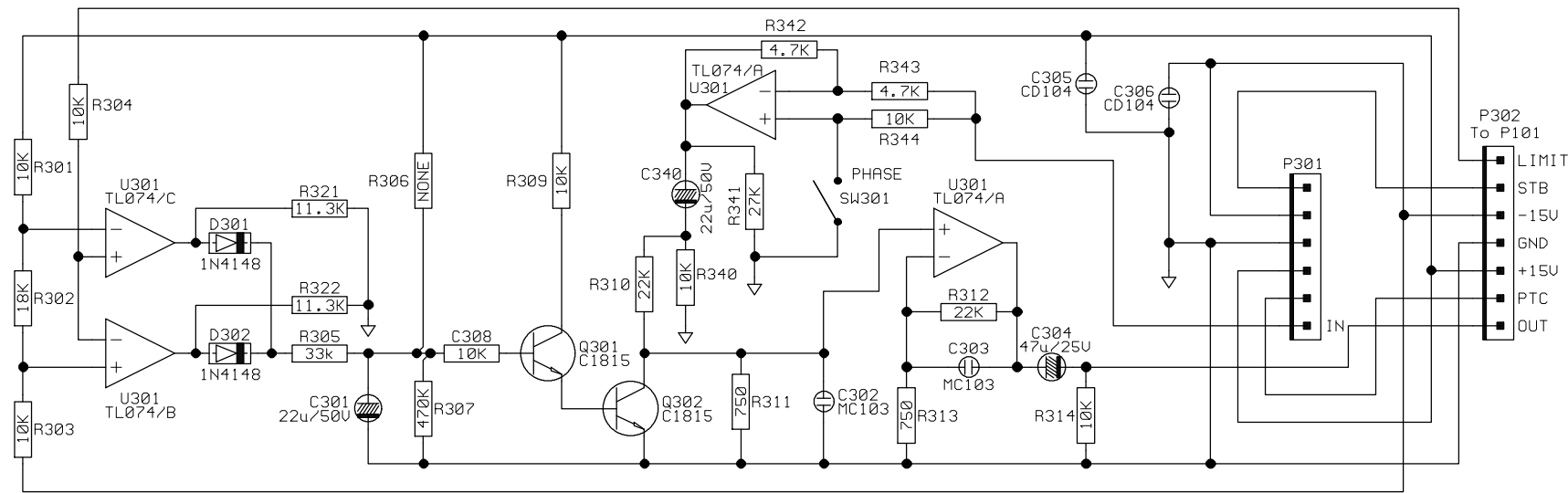

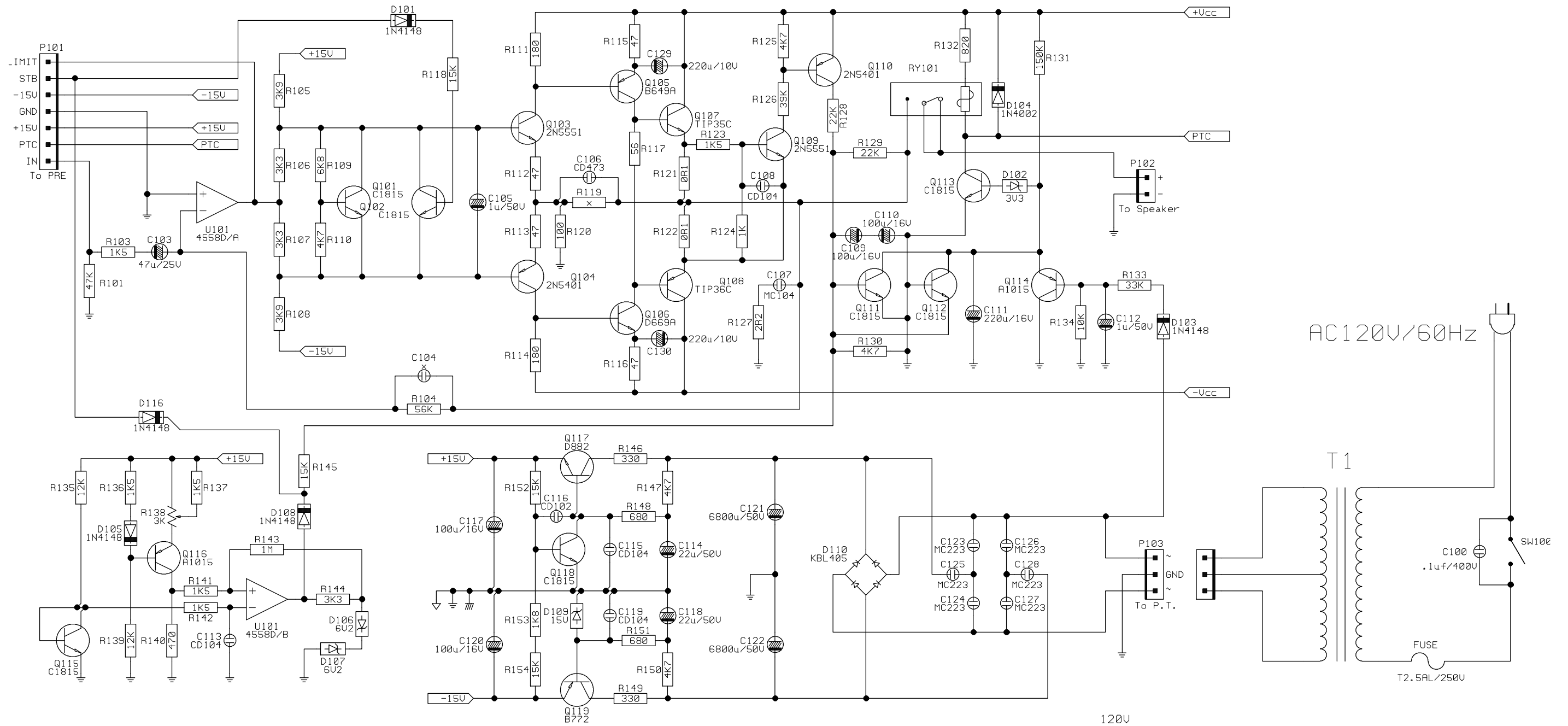

Infinity primus ps-8

DRAW.	DSGN.	APVD.	FILENAME : PS8U.SCH	REVISION :
			MODEL NO. 010-7510-00326	1
			DWN BY : C.S.WANG	2
			DATE : 2004-2-20	3

PS-8

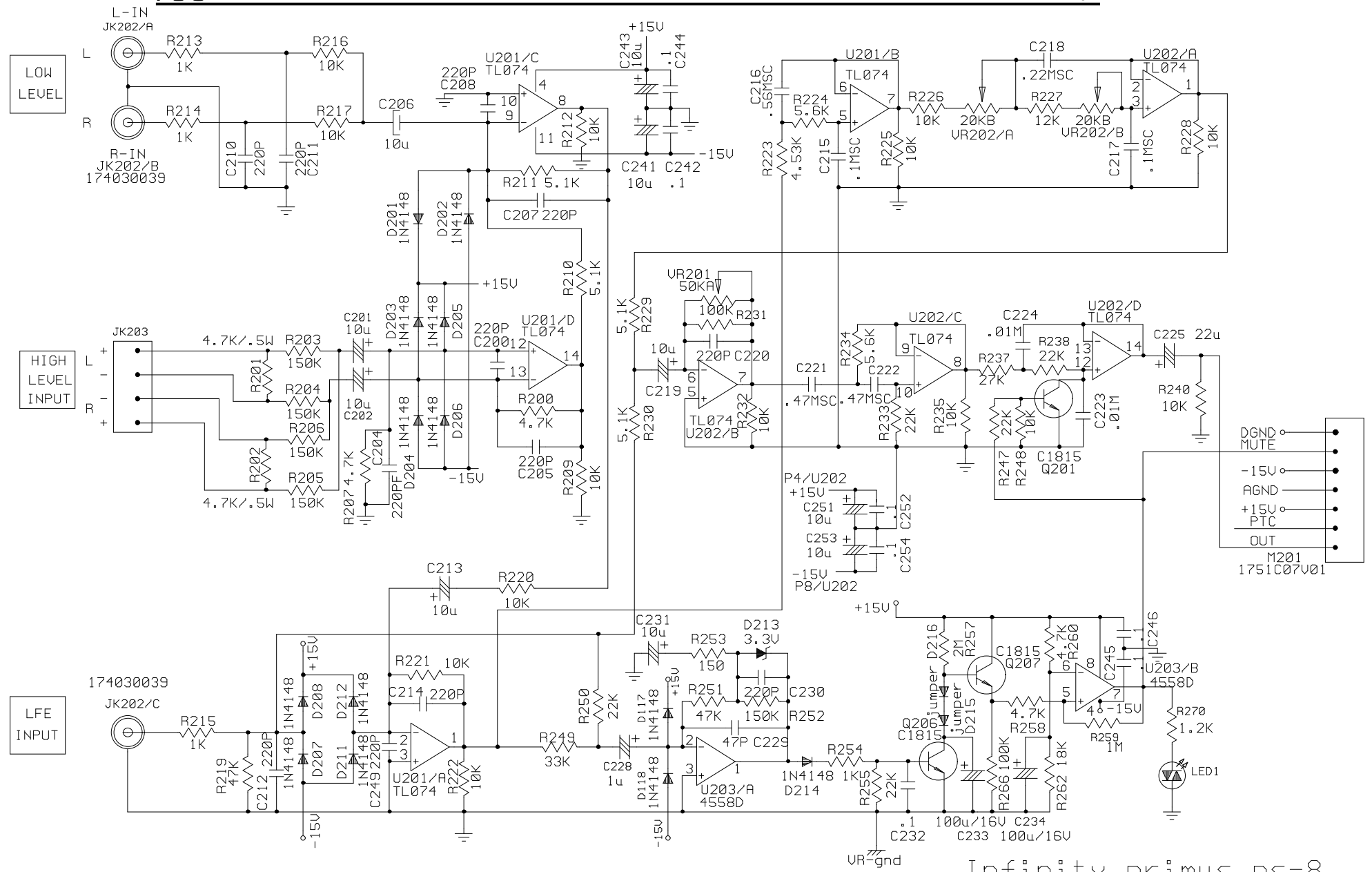

Infinity primus ps-8

REV:2

APPROVE BY	CHECK BY	DRAWING BY	NAME:	PRE-AMP	2 / 3
			MODEL:	PS-8	REV:A2
			CUSTOMER:	INFINITY	
			DATE:	2006.8.30	

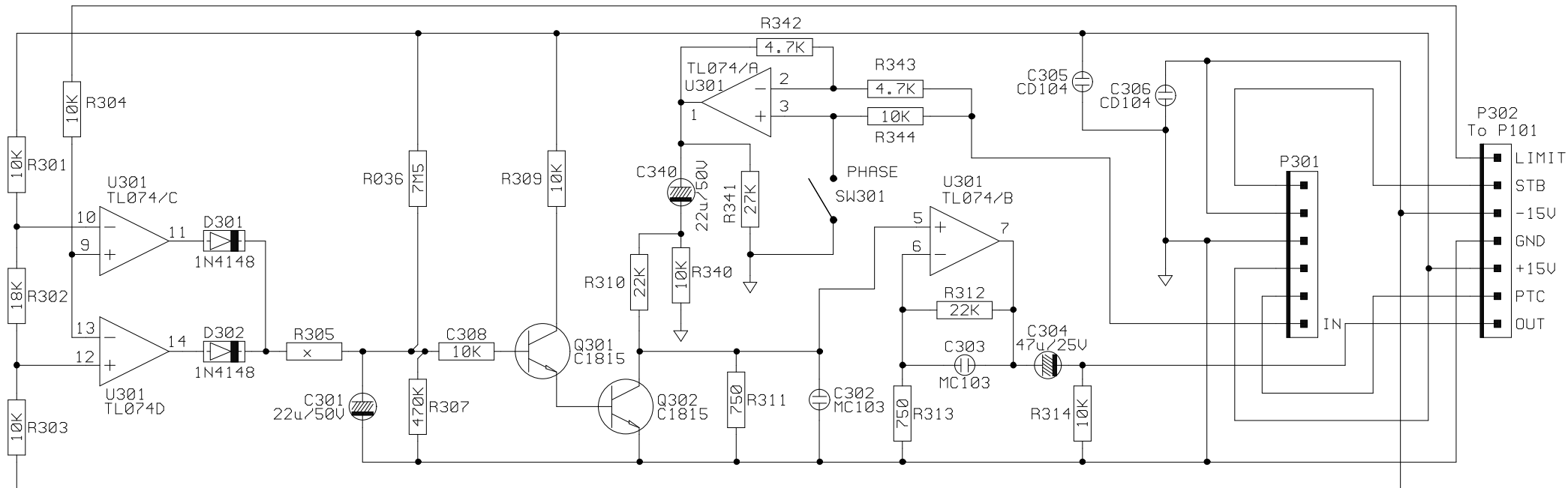

Infinity primus ps-8
REV:2

APPROVE BY	CHECK BY	DRAWING BY	NAME: LIMIT	2 / 3
			MODEL: PS-8	REV:A2
			CUSTOMER: INFINITY	
			DATE: 2006.8.30	

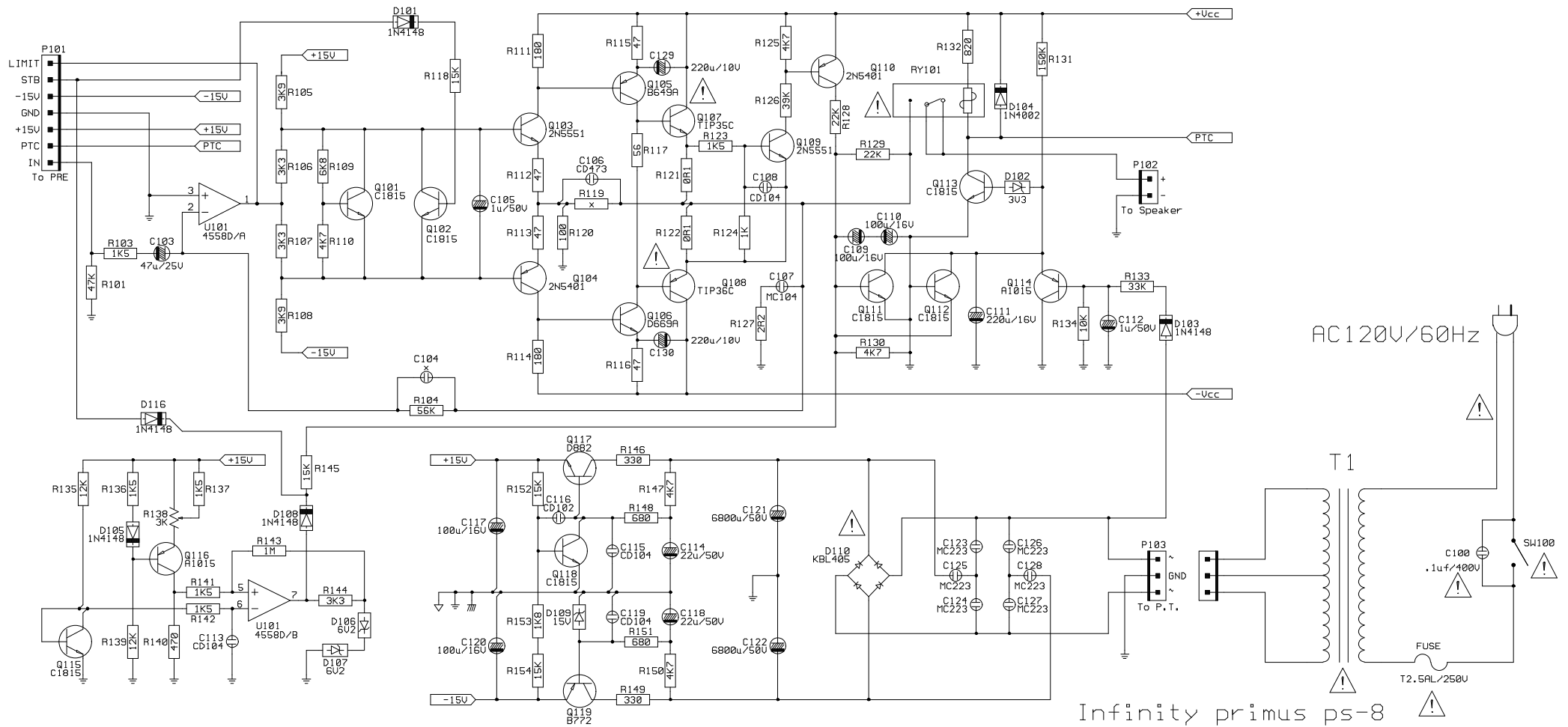

Infinity primus ps-8

REV:2

APPROVE BY	CHECK BY	DRAWING BY	NAME: POWER-AMP	3 / 3
			MODEL: PS-8	REV:A2
			CUSTOMER: INFINITY	
			DATE: 2006.8.30	

PS-8 PACKAGE

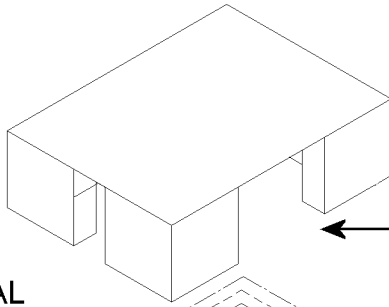

431-000-00944T

OWNER'S MANUAL
398-PAP-00291

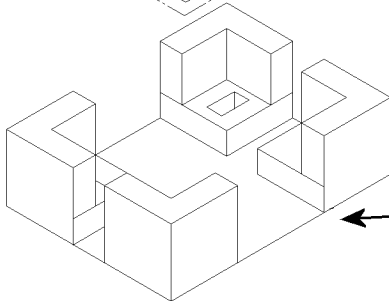
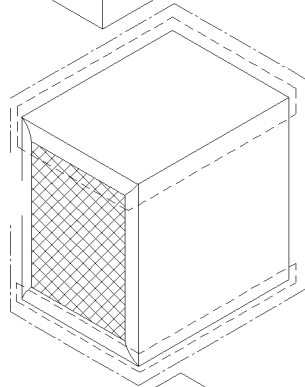

431-000-00944B

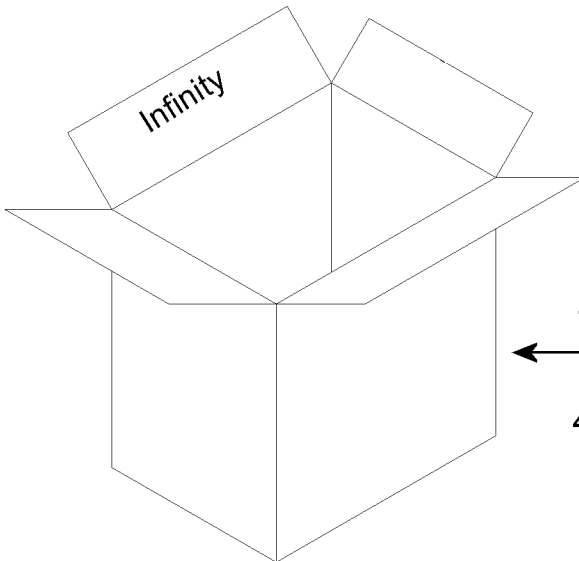

400-000-04575
(BEECH)

400-000-04346
(BLACK)