



Classia Series

PSW310W

Wireless Powered Subwoofer

Service Manual



Infinity Systems, Inc.
250 Crossways Park Dr.

Woodbury, New York 11797

Released 2008

Discontinued XXXX

Rev3 3/2009

- CONTENTS -

BASIC SPECIFICATIONS	1
DETAILED SPECIFICATIONS	2
PACKAGING.....	5
CONTROLS/CONNECTIONS.....	6
OPERATION	8
SUBWOOFER EXPLODED VIEW/PARTS LIST	9
TRANSMITTER EXPLODED VIEW/PARTS LIST	10
TEST SET-UP AND PROCEDURE.....	11
AMPLIFIER BLOCK DIAGRAM.....	13
SUBWOOFER AMP TROUBLESHOOTING.....	14
TRANSMITTER TROUBLESHOOTING.....	15
RECEIVER PCB TROUBLESHOOTING.....	16
P.C.B. DRAWINGS.....	17
ELECTRICAL PARTS LIST	26
IC/TRANSISTOR PINOUTS.....	32
SCHEMATICS.....	46

Basic Specifications Infinity Classia PSW310W

Frequency Response:	32Hz – 150Hz (–3dB) 28Hz – 150Hz (–6dB)
Amplifier RMS Power:	400 Watts
Amplifier Peak Dynamic Power *:	700 Watts
Crossover Frequencies:	50Hz – 150Hz, continuously adjustable when activated
Driver:	10" (254mm) CMMD® Dual 10" (254mm) CMMD passive radiators
RF Operating Frequency:	2.4GHz
Operating Range:	Up to 75' (22m), depending upon conditions
Subwoofer Dimensions (H x W x D):	17-1/2" x 14" x 16-3/4" (445mm x 356mm x 426mm)
Subwoofer Weight:	49.8 lb (22.6kg)
Transmitter Dimensions:	3-3/4" x 4-7/8" x 3-15/16" (95mm x 124mm x 100mm)
Transmitter Weight:	0.5 lb (0.2kg)

Infinity continually strives to update and improve existing products, as well as create new ones. The specifications and construction details in this and related Infinity publications are therefore subject to change without notice.

* The peak dynamic power is measured by recording the highest center-to-peak voltage measured across the output of a resistive load equal to minimum impedance of the transducer, using a 50Hz sine wave burst, 3 cycles on, 17 cycles off.

PSW310W		250W Powered Sub Amp				
LINE VOLTAGE	Yes/No	Hi/Lo Line	Nom.	Unit	Notes	
US 120vac/60Hz	Yes	108-132	120	Vrms	Normal Operation	
EU 230vac/50-60Hz	Yes	207-253	230	Vrms	Normal operation, MOMS required	
Parameter	Specification	Unit	QA Test Limits	Conditions	Notes	
Amp Section						
Type (Class AB, D, other)	D	n/a	n/a			
Load Impedance (speaker)	4	Ohms	n/a	Nominal		
AVG System impedance	5.3	Ohms	n/a	AP Computed BW from 20 to 500Hz		
Min System impedance	3.6	Ohms	n/a	@ 100 Hz		
Rated Output Power (120VAC)	250	Watts	250		Domestic version only 120 VAC-60 Hz	
AVG RMS Dynamic Power	300	312	Reference	800mV driven into a single input L or R	Average RMS power, 3/20 Cycles 50 Hz, Driven 6dB above its input sensitivity , average of the RMS value for the first 4 consecutive peaks	
THD @ Rated Power	0.5	%	1	22K filter		
THD @ 1 Watt	0.2	%	0.3	22K filter		
DC Offset	10	mV-DC	30	@ Speaker Outputs		
Damping factor	>50	DF	20	Measured at amplifier board 90% of full power	Measured at the speaker cable. 225 Watts @ THD < 0.1 % @ 50 Hz	
Input Sensitivity						
Input Frequency	50	Hz	50	Nominal Freq.		
L or R	28.69	mVrms	±1dB	To 1 Watt	Single input driven	
LFE input	14.93	mVrms	±1dB	To 1 Watt	Single input driven, LFE switch ON	
System Gain (L or R inputs)	36.86	dB	Reference		Single input driven L or R inputs (Local inputs)	
System Gain (LFE input)	42.53	dB	Reference		Single input driven LFE Mode local input	
Signal to Noise						
SNR-A-Weighted	80	dBA	75	relative to 1W	A-Weighting filter	
SNR-unweighted	70	dBr	65	relative to 1W	22K filter	
Residual Noise Floor	<1.5	mVrms(max)	2.5	Volume @max, w/ A/P Swept Bandpass Measurement (Line freq.+ harmonics) (BW=20 KHz)	Line level inputs must be terminated using 1KOHM	
Input Impedance						
Line Input (L, R,LFE)	10K	ohms	n/a	Nominal		
Filters						
LP filter Variable	50-150	Hz	± 10		4th Order variable-24 db/Octave	
Subsonic filter (HPF) 2nd Order	Fixed					
Friend circuit	Fixed					
LFE Low pass	200>LP<500	Hz		LFE input driven only		
Limiters						
THD at Max. Output Power	5	%	functional	Drive unit 6dB above the required level to obtain full power Approximately 800mV single input driven, L or R input	Maximum THD as a result of limiting.	
Features						
Volume pot Taper (lin/log)	LOG	--	functional		A Taper	
Phase switch	0-180	deg	functional			
LP Filter defeat switch	YES		functional		Disables LP filter, Wireless mode only, it has no effect when using local inputs	
Wireless ready	YES		functional		Refer to Wireless section below	
Wireless channels	4	n/a	functional		System is provided with 4 wireless channels, which can be selected via a rear panel switch, channel should match ID at	
LED Indicator	YES		functional		RED-Standby, GRN-Active, ORG-Wireless link and subwoofer are active.	
Input Configuration						
Line in (L,R) & LFE	YES	--	functional		Dual RCA jack	

Parameter	Specification	Unit	QA Test Limits	Conditions	Notes
Signal Sensing (ATO)					
Auto-Turn-On (yes/no)	YES		functional		
ATO Input test frequency	50	Hz	functional		
ATO Level LFE Input	2	mV	functional		Maximum acceptable level.
ATO Turn-on time	5	ms	functional	Amp connected and AC on, then input signal applied	
Auto Mute/ Turn-OFF Time	5-15	minutes	5-15	T before muting, after signal is removed	Auto turn of time (T) must be 5 > T < 15 Minutes
Power on Delay time	3	sec.	4	AC Power Applied	
Transients/Pops					
ATO Transient	0.5	V-peak	0.5V	@ Speaker Output	Amplifier activated by signal presence at the Line input
Turn-on Transient	0.5	V-peak	0.8V	@ Speaker Output	AC Line cycled from OFF to ON
Turn-off Transient	0.5	V-peak	0.8V	@ Speaker Output	AC Line cycled from ON to OFF
Efficiency					
Efficiency	65	%	60	Test conducted at rated power 250W	Nominal Line voltage
Efficiency at 1/8 of rated power	48	%	45	Test conducted at 31.25 WRMS	Nominal Line voltage-Rated impedance 4 Ohms
Standby Input power	10	Watts	12		Nominal Line voltage RED LED
Idle input power	14	Watts	20	@ nom. line voltage	Maximum allowable input power under nominal Input voltage and frequency, HOT or COLD operation. LED GREEN no signal applied
Power Cons. @ rated power	393	Watts	416	@ nom. line voltage	250 Watts @ 4 Ohms nominal line voltage
Protections					
Short Circuit Protection	YES		functional	Direct short at output	Amplifier should resume operation after short circuit condition removal
Thermal Protection	YES		functional	@1/8 max unclipped Power at 1.06 times the input voltage	Temperature rise in accessible metal parts should not exceed 35K rise for domestic version or 30K rise for European versions (refer to requirements sheet).
DC Offset Protection	YES		-	DC present at Speaker Out leads	Design must insure no Offset/DC Voltage at the speaker output under any operating condition including abnormal operation
Line Fuse Rating					
USA-Domestic	3.15	Amps	3.15	Type-T or Slo Blo-250 V	Internal fuse with UL/SEMKO rated holder
EU	2	Amps	2	Type-T or Slo Blo-250 V, Low Breaking capacity	Internal fuse with UL/SEMKO rated holder
Mechanical					
System weight	55	Lbs	Reference		
Dimensions WxHxD	14x17.5x 15.5	inches	Reference		
SYSTEM PERFORMANCE USING WIRELESS Tx					
THD @ 1 Watt	0.2	%	0.3	22K filter	
Tx Input Impedance					
Line Input (LFE)	7.3K	ohms	n/a	Nominal @ 1KHz	
System Sensitivity					
Input Frequency	50	Hz	50	Nominal Freq.	System level, using Tx
LFE Input	15.84	mVrms	±1dB	To 1 Watt	System level, using Tx
System gain	42	dB	±1dB	To 1 Watt	System level, using Tx
System Signal to Noise					
SNR-A-Weighted	65	dBA	65	relative to 1W	A-Weighting filter
SNR-unweighted	55	dBr	55	relative to 1W	22K filter
Filters					
System filter	None	Hz		Should not have any effect on the FR of the system	
Tx Limiter					
THD at Max. Output Power	5.7	Vrms	functional		Max input voltage Tx front end can handle without exceeding 1% THD

Parameter	Specification	Unit	QA Test Limits	Conditions	Notes
Tx-Signal Sensing (ATO)					
Auto-Turn-On (yes/no)	YES		functional		
ATO Input test frequency	50	Hz	functional		
ATO Level LFE Input	2	mV	functional		
Auto Mute/ Turn-OFF Time	5-15	minutes	5-15	T before muting, after signal is removed	Auto turn of time (T) must be 5 > T < 15 Minutes
Tx Features					
LFE Input	YES	--	functional		Single RCA Connector
Channel ID switch	YES		functional		4 Position switch, to select wireless channels
External power supply requirements	18	VDC	functional		System provided with Power supply model GPE-152, delivering 18VDC @ 500mA
Power consumption					
Tx Power supply requirements	18	V	Reference		
Tx Current consumption		Amperes	Reference		
Tx Standby Input Power	1	Watts	Reference	120VAC line voltage	RED LED
Tx Standby input current	0.019	Amperes	Reference	120VAC line voltage	RED LED
Tx Idle Power	2.34	Watts	Reference	120VAC line voltage	Unit in operation Locked to Rx section Solid GRN
Tx Idle Power	1.64	Watts	Reference	120VAC line voltage	Unit in operation NOT locked to Rx section
Other Parameters/Notes:					
Volume control should be <i>at the input buffer stage</i> in order to lessen the possibility of clipping the input section with highly dynamic audio material.					
ALL SPECS SHOULD BE MEASURED AT NOMINAL LINE VOLTAGE.					

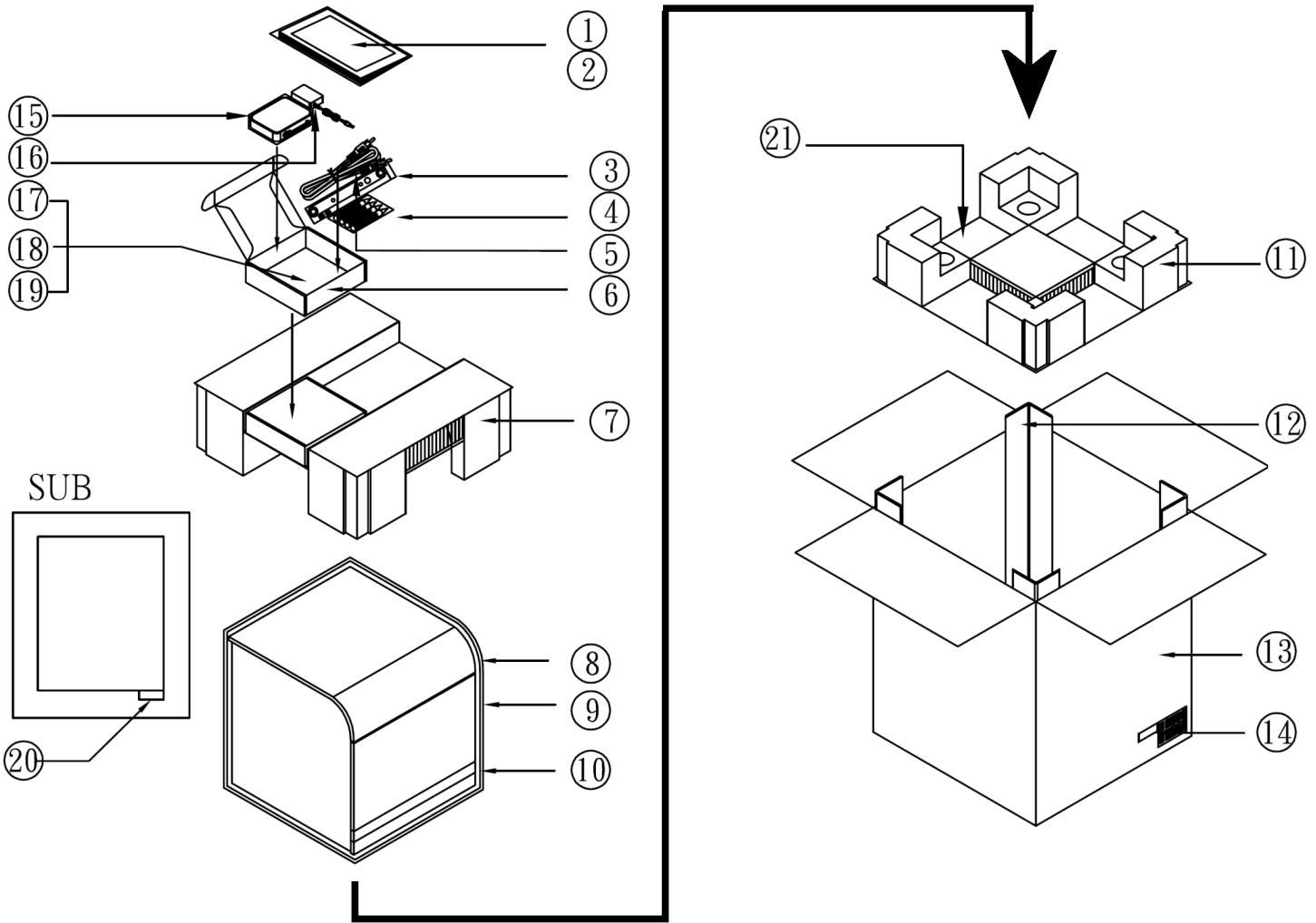

ITEM #	PART NUMBER	DESCRIPTION	QTY
1	405-000-05110-E	Warranty Card	1
2	Visit www.infinitysystems.com	Owner's Manual	1
3	376-000-01092-E	Wall Mount Bracket w/ 2 screws, for transmitter	1
4	373-000-05099-E	Spiked feet for subwoofer (set 4)	1
5	165-02000101-E	6' Audio cable, RCA-RCA	1
6		Accessory Box	1
7	431-000-06470-E	Top End Pad	1
8		Packing Bag	1
9		Plastic Bag	1
10		Label	1
11	431-000-06471-E	Bottom End Pad	1
12		L-shaped corner guards	1
13	400-000-08120-E	Outer Carton PSW310W (Black)	1
	400-000-08621-E	Outer Carton PSW310W (Cherry)	1
14		Serial Number Label	1
15	PSW310W120V-LAUNCH or 015-7500-00036-E	Transmitter	1
16	151-OGPE15200-E	Power Supply, transmitter, 120v AC cord for Power Supply	1
17	373-000-05067-E	Adhesive feet, round, (set 4)	1
18	370-000-05068-E	15' Audio cable, RCA-RCA	1
19	152-U602015A-E	120v AC cord for PSW310W	1
20		Serial Number Label	1
21		Desiccant	1

CONTROLS AND CONNECTIONS

Rear Panel

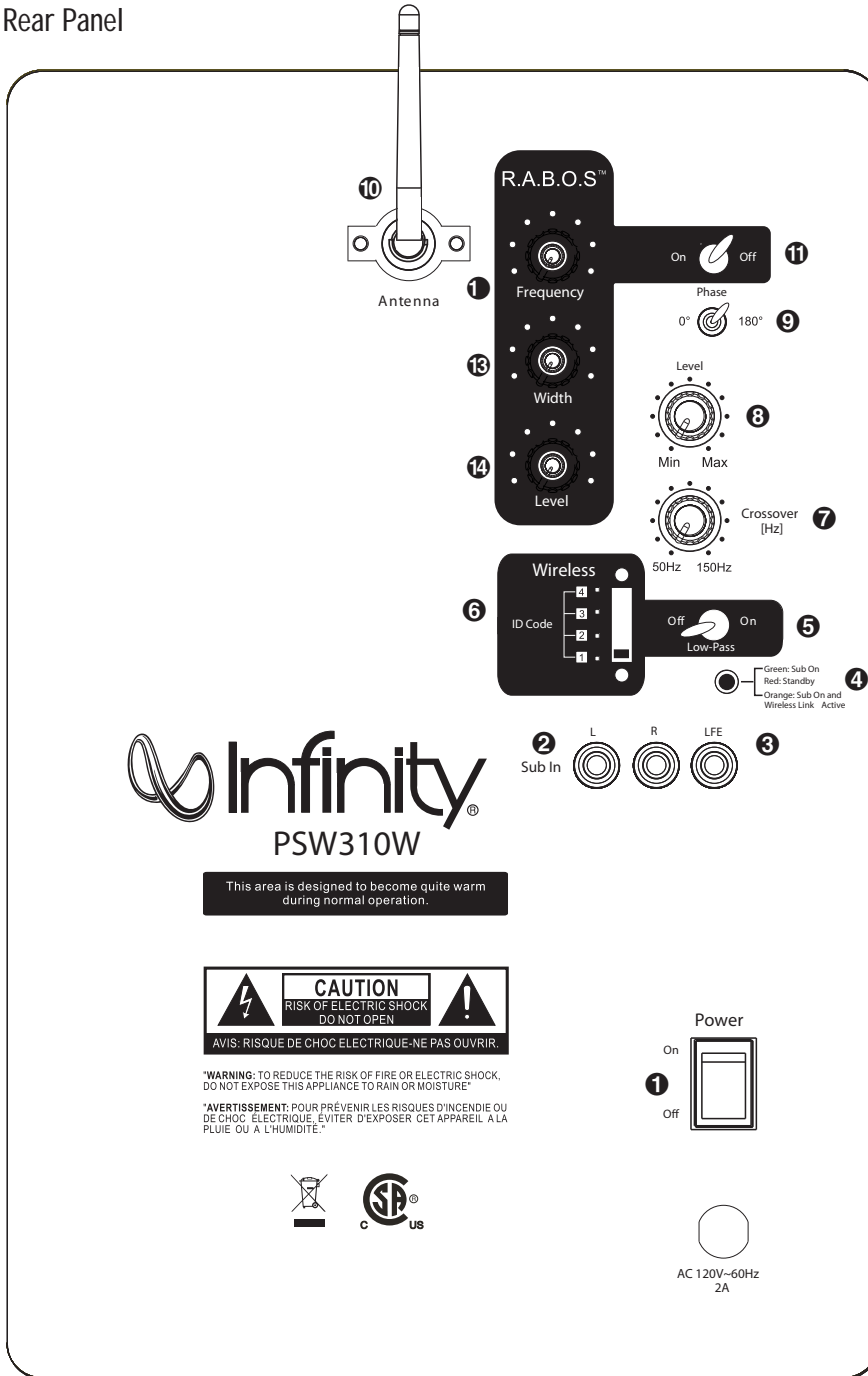

- 1 Power Switch
 - 2 Line-Level Inputs
 - 3 LFE Input
 - 4 Power Indicator LED
 - 5 Low-Pass Selector
 - 6 ID-Code Selector
 - 7 Crossover Adjustment Control
 - 8 Subwoofer-Level (Volume) Control
 - 9 Phase Switch
 - 10 Wireless Antenna
- Room Adaptive Bass Optimization Controls (see page 5)
- 11 R.A.B.O.S. Selector
 - 12 R.A.B.O.S. Center-Frequency Adjustment
 - 13 R.A.B.O.S. Bandwidth Adjustment
 - 14 R.A.B.O.S. Level Adjustment
- Transmitter
- 15 Transmitter Antenna
 - 16 Transmitter Power-Supply Input
 - 17 Transmitter ID-Code Selector
 - 18 Transmitter Sub Input

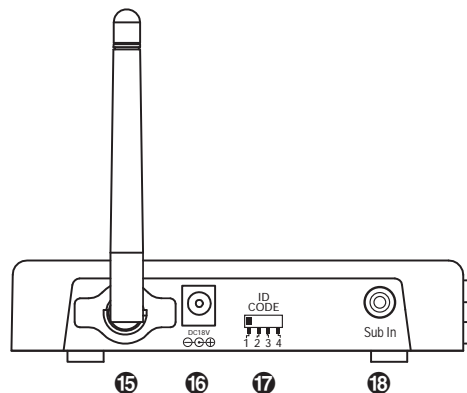

SYSTEM CONNECTIONS

Choose either Wireless or Wired connection, then follow the appropriate instructions.

WIRELESS

Connecting the Subwoofer for Wireless Applications

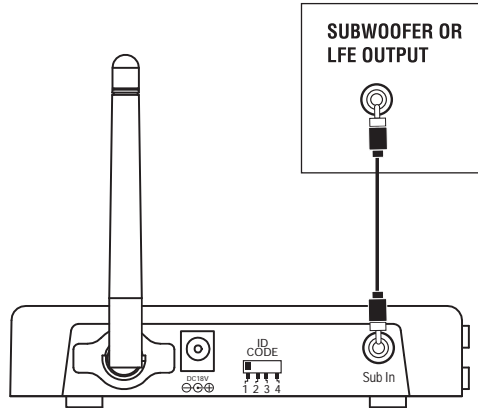

Step 1.
Connect a subwoofer cable from the subwoofer or LFE output of your receiver to the Sub In 13 on the transmitter.

Step 2.
Plug the transmitter module into the wall outlet, and connect the included power supply and power cord to the transmitter 16. Make sure the Transmitter Antenna 15 is extended upward.

Step 3.
Set the ID code on the transmitter and subwoofer (17 and 6) to the same position, as described on page 4. When connected properly, the LED 4 on the rear of the subwoofer will be orange.

Step 4.
Set the Low-Pass Selector 5 to the "Off" position.

NOTE: Some receivers have two subwoofer outputs. In that case, use either one of the connectors.

WIRED

Connecting the Subwoofer for Wired Applications

If you have a Dolby® Digital or DTS® receiver/processor with a low-frequency effects (LFE) or subwoofer output:

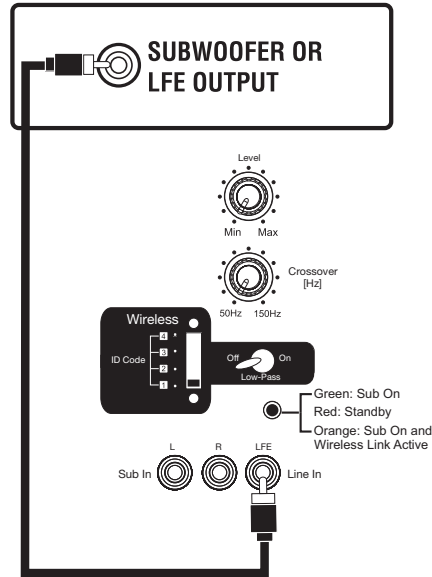

If your receiver/processor does not contain a Dolby Digital or DTS processor but has subwoofer outputs:

RECEIVER/PROCESSOR

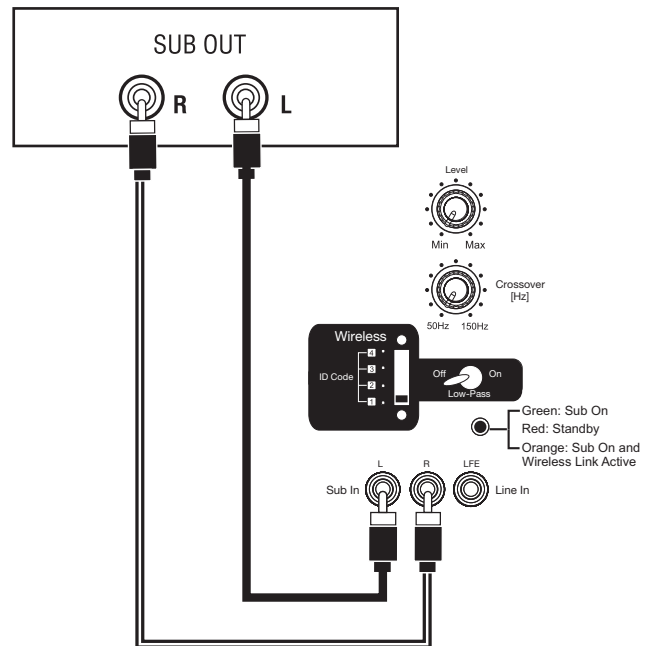

NOTE: If your receiver/processor has only one sub out, you may use either the L or R input.

OPERATION

Power On

Connect your signal source (such as an A/V receiver or preamplifier) to the transmitter (if using wireless connection) or to the subwoofer (if using wired connection). Two single-RCA cords are provided. While you would ordinarily use the short cable to connect to the transmitter or the long one to connect to the subwoofer, either cable can be used, depending on proximity to the signal source. There is no need or benefit gained from connecting the same source to both the transmitter and the subwoofer. However, you could connect two separate sources to this subwoofer by utilizing both its wired and wireless connections. Both signals will essentially be mixed and outputted by the subwoofer. Plug your transmitter's (if using wireless connection) and subwoofer's AC cord into a wall outlet. Do not use the outlets on the back of the receiver for the subwoofer.

Initially set the Subwoofer-Level Control **8** to the "Min" position. Turn on your sub by pressing the Power Switch **1** on the rear panel. Turn on your entire audio system and start a CD or movie soundtrack at a moderate level.

Auto On/Standby

Transmitter (wireless connection only): The Power Indicator LED (not shown) will be lit in red when the unit is in standby. When the transmitter receives an audio signal from the source, it will immediately turn on and the LED will turn to blinking green or solid green:

RED = STANDBY (No signal detected, transmitter off)

GREEN (BLINKING) = Transmitter is on but has not established a link with the wireless sub.

GREEN (SOLID) = Transmitter is on and has already established a link with the wireless sub.

The transmitter will automatically enter Standby mode after approximately 10 minutes when no signal is detected from your system.

Subwoofer: With the Power Switch **1** in the "On" position, the Power Indicator LED **4** on the back panel will remain lit to indicate the On/Standby mode of the subwoofer.

RED = STANDBY (No signal detected, amp off)

GREEN = SUB ON (Wired signal detected, amp on)

ORANGE = SUB ON (Wireless link with transmitter active)

The subwoofer will automatically enter Standby mode after approximately 10 minutes when no signal is detected from your system. The subwoofer will then power on instantly when a signal is detected. During periods of normal use, the Power Switch **1** can be left on. You may turn off the Power Switch **1** for extended periods of nonoperation, e.g., when you are away on vacation.

Getting Started

Confirm that the Status LED on the transmitter (not shown) is on (red or green) and the Status (Power Indicator) LED **4** on the subwoofer is on (red, orange or green) and that an RCA cable is connected from a source unit to either the LFE Input **3** of the subwoofer or transmitter **18** or L and R inputs **2** on the subwoofer. Play a CD or video. Use a selection that has ample bass information. If using a wireless connection, the Status LED on the transmitter should be lit in solid green, and the Status LED **4** on the subwoofer should turn orange if connected wirelessly. If the LED on the transmitter is blinking in green and the LED on the subwoofer is in red or green, a wireless link has not been established between the transmitter and the subwoofer. If connecting directly to the subwoofer without using the wireless link, the Status LED **4** on the subwoofer should be lit green. If the LED on the subwoofer remains red, check that the RCA cable from the source to the subwoofer (wired connection) or transmitter (wireless connection) is functioning properly (wired connection) and that it is fully inserted at both ends, or that the Transmitter ID-Code Selector **17** and the Subwoofer ID-Code Selector **6** are set to the same channel.

Once you have a green or orange LED on the subwoofer, turn your Subwoofer-Level Control **8** up halfway so that the knob indicator points up. You should now be hearing bass information coming from the subwoofer.

Adjust Level

Set the overall volume control of the preamplifier or stereo to a comfortable level. Adjust the Subwoofer-Level Control **8** until you obtain a pleasing blend of bass. Bass response should not overpower the room but rather be adjusted so there is a harmonious blend across the entire musical range. Many users have a tendency to set the subwoofer volume too loud, adhering to the belief that a subwoofer is there to produce lots of bass. This is not entirely true. A subwoofer should enhance bass, extending the response of the entire system so the bass can be felt as well as heard. However, overall balance must be maintained or the music will not sound natural. An experienced listener will set the volume of the subwoofer so its impact on bass response is always there but is never obtrusive.

Phase Control

The Phase Switch **9** determines whether the subwoofer driver's piston-like action moves in and out with the main speakers, 0°, or opposite the main speakers, 180°. Proper phase adjustment depends on several variables such as room size, subwoofer placement and listener position. Adjust the Phase Switch **9** to maximize bass output at the listening position.

Crossover Adjustment

The Crossover Adjustment Control **7** determines the highest frequency at which the subwoofer reproduces sounds. If your main speakers can comfortably reproduce some low-frequency sounds, set this control to a lower frequency setting, between 50Hz and 100Hz. This will concentrate the subwoofer's efforts on the ultradeep bass sounds required by today's films and music. If you are using smaller bookshelf speakers that do not extend to the lower bass frequencies, set the Crossover Adjustment Control **7** to a higher setting, between 120Hz and 150Hz.

NOTE: This control will have no effect if the LFE Input **3** is used (wired connection) or if the Low-Pass Selector **5** is in the "OFF" position (wireless connection). If you have a Dolby Digital or DTS processor/receiver, the low-pass frequency is set by the processor/receiver. Consult your owner's manual to learn how to view or change this setting.

ID Codes

In the unlikely event that you experience interference when operating the system, or if you have more than one set of subwoofer transmitters and receivers in operation, you may change the channel in which the system operates. On the transmitter module and the subwoofer, there is a four-position ID-Code Selector (**17** and **6**). Simply set the selectors to one of the other positions. The transmitter and subwoofer (**17** and **6**) selectors must be set to the same position for the system to function correctly. You can also set up a maximum of two subwoofers to be receiving from the same transmitter by setting the channel selector on the transmitter and both of the subwoofers to the same channel.

A Word About Wireless Products

The Infinity Classia PSW310W wireless subwoofer utilizes advanced wireless transceivers operating in the 2.4GHz frequency band. This is the same frequency band that is used for wireless home networks and high-quality cordless phones. It also allows for the transmission of high-performance, full-spectrum sound to remote locations, wirelessly.

Like all wireless devices, the Infinity PSW310W wireless subwoofer's operating range may vary, depending upon variables such as building construction methods and materials, atmospheric conditions and other sources of interference. Please consult your Infinity dealer or distributor, or visit www.infinitysystems.com, for further information or assistance.

EXPLODED VIEW

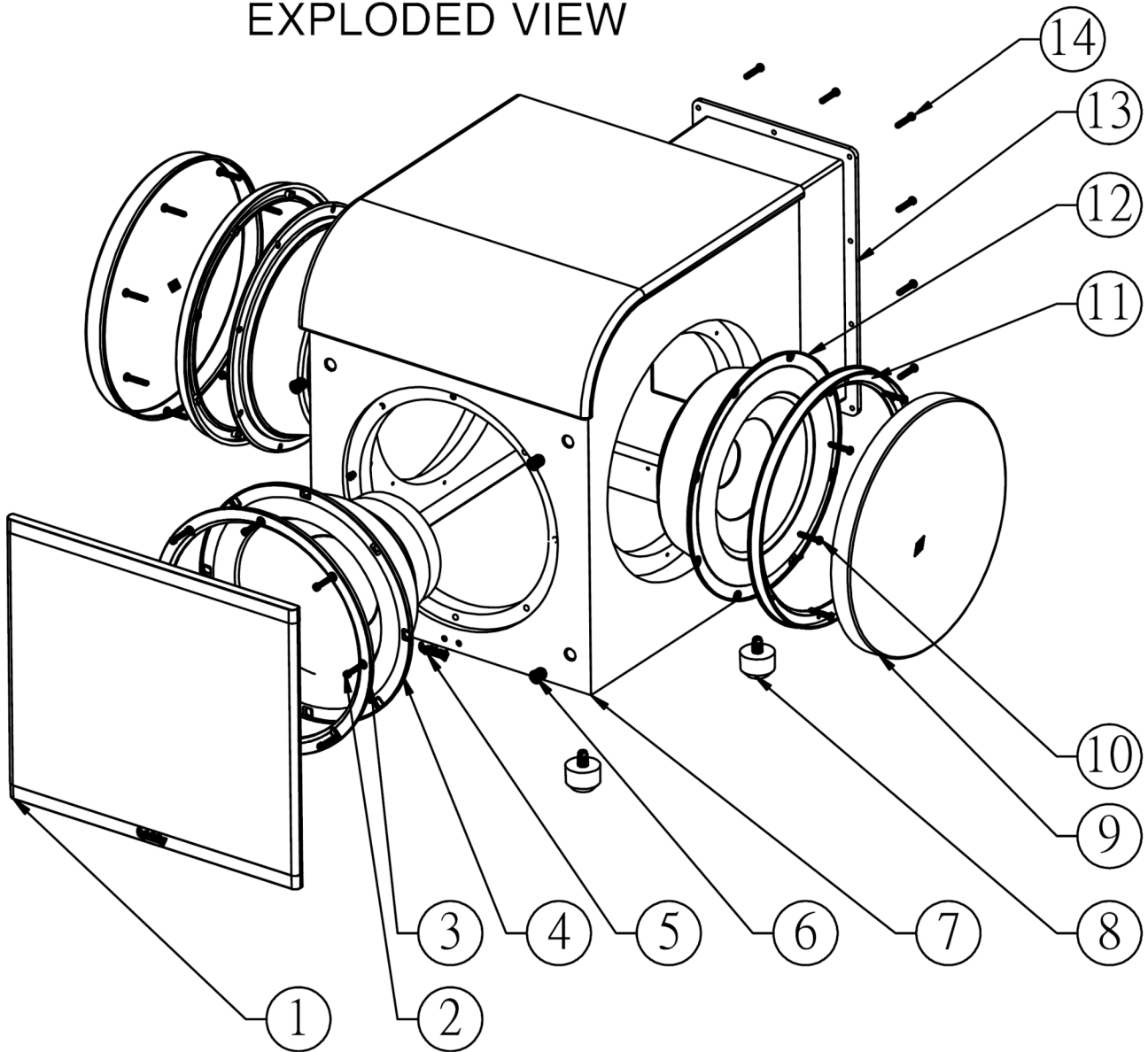

ITEM	DESCRIPTION	PART NUMBER	QTY
1	Front Grille	363833-001	1
2	Screw, woofer	352-KM04027D344-E	8
3	Trim ring, woofer	213-100-05157-0VAE	1
4	10" (254mm) CMMD ® Woofer	25PR12FZL-DW05-E	1
5	Infinity Logo	316-ABS-00550-E	1
6	Grille cup	327-010-05039-0BAE	4
7	PSW310W Cabinet BK,CH	Not for Sale	1
8	Foot	321-RUB-05118-0BAE	4
9	Round Grille, passive, side	328-100-05342-2BAE	2
10	Screw, passive radiator	352-FM04020D605-E	16
11	Trim ring, passive radiator	213-100-05159-0BAE	2
12	10" (254mm) Passive Radiator	PR-255012-E	2
13	PSW310W Amplifier	Not for Sale	1
14	Screw, amplifier	352-AM04020D210-E	10

PSW310W TRANSMITTER

Part #

PSW310W120V-LAUNCH

or 015-7500-00036-E

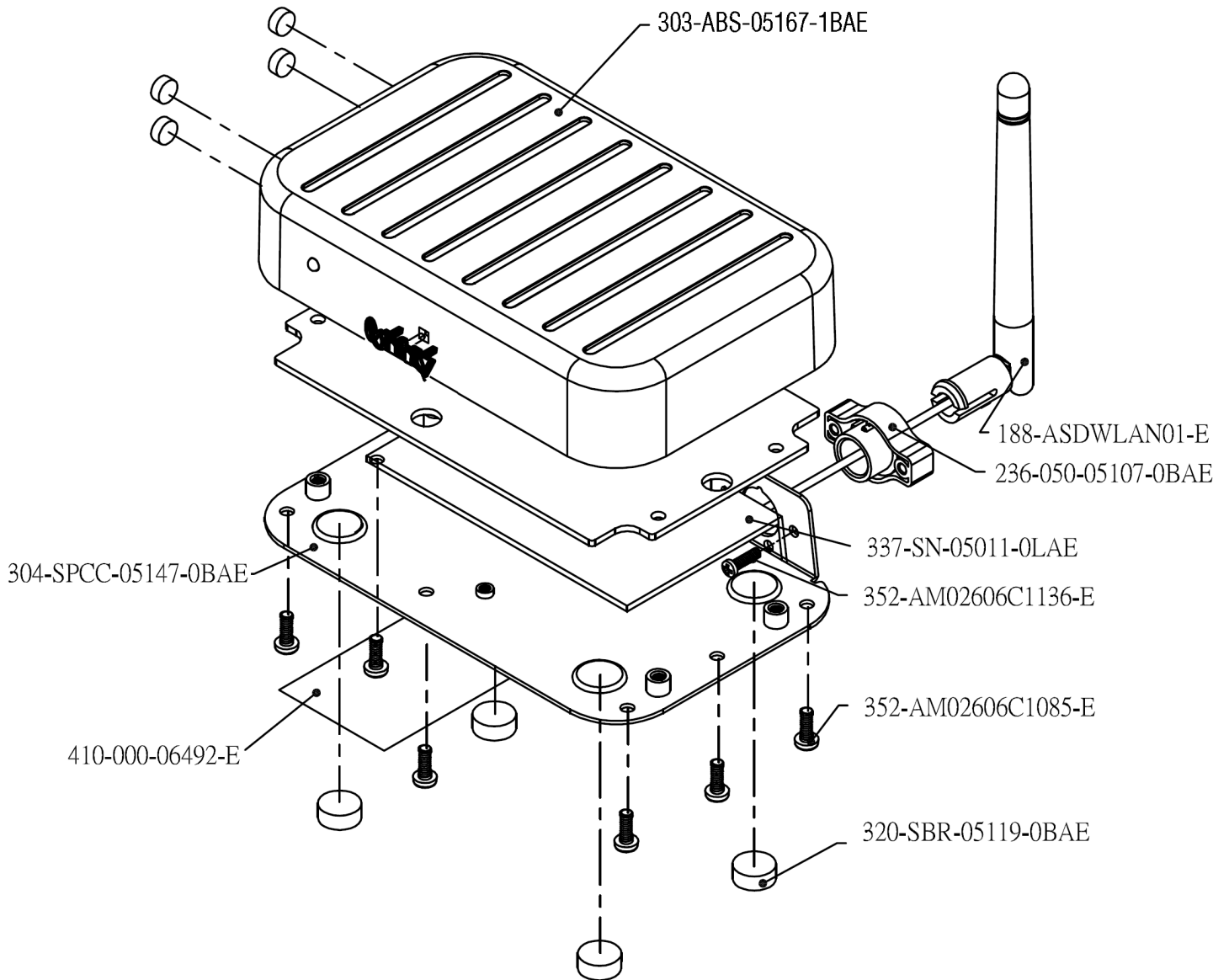

PSW310W Test Set Up and Procedure

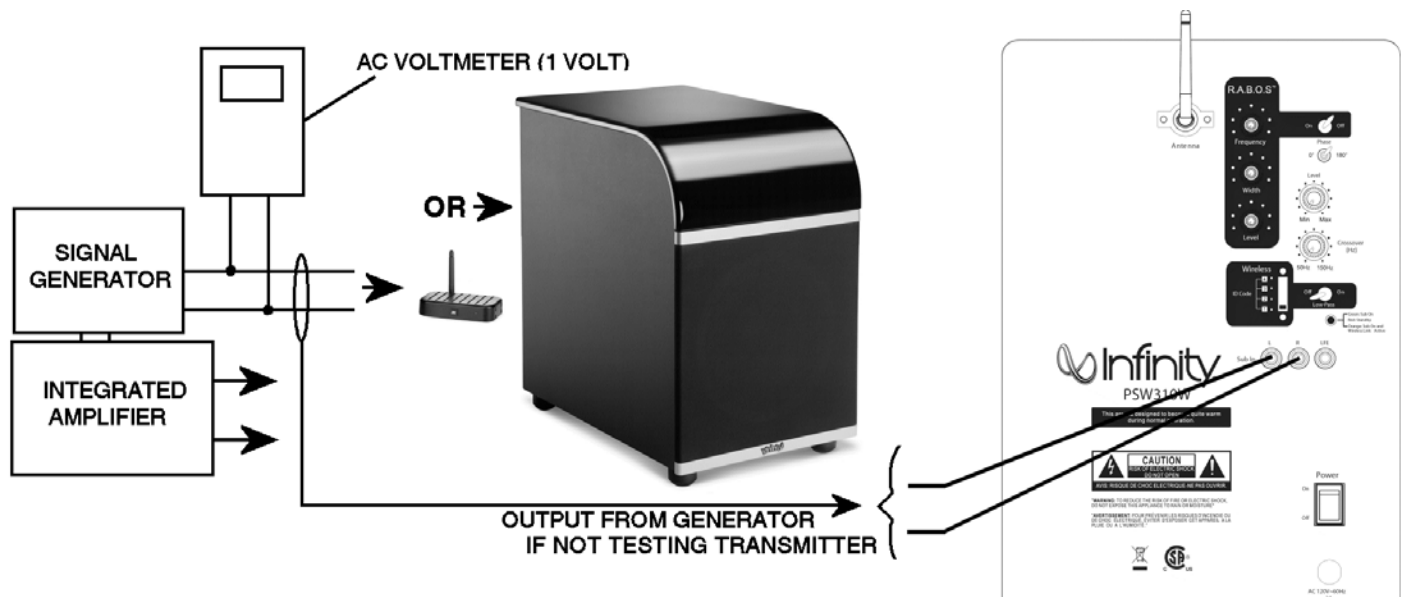

The operation of the PSW310W subwoofer, and the proper settings for the Room Adaptive Bass Optimization System, or R.A.B.O.S., is thoroughly covered in the Owner's guide, available from www.infinitysystems.com. For service purposes, the R.A.B.O.S. system is canceled when all three front panel controls (F) (L) (W) are turned fully CW (Clockwise), or if the R.A.B.O.S. On/Off switch is OFF. The only other control of concern is the Main Level Control on the front panel, which operates like a traditional potentiometer.

Equipment needed:

- Function/signal generator/sweep generator
- Integrated Amplifier
- Multimeter
- Speaker cables
- PSW310W Transmitter, power supply

General Unit Function + Transmitter (UUT = Unit Under Test)

- 1) From a mono output signal generator, OFF at this time, connect an RCA cable to the "Sub in" jack on the PSW310W Transmitter. Assure the power supply has been plugged in and a Red or blinking Green LED is now showing on the transmitter. Default "ID Code" switch position is 1.
- 2) Position and plug in the PSW310W Subwoofer nearby (less than 75' away), power switch should be OFF.
- 3) CROSSOVER, PHASE controls do not matter for this test. Low Pass switch should be OFF. "ID Code" switch position should be 1. RABOS On/Off switch should be OFF.
- 4) Turn the LEVEL control on the UUT to completely counterclockwise (MIN).
- 5) Turn on signal generator; adjust to **125mV, 50 Hz**. LED on Transmitter should now be steady Green.
- 6) Turn Subwoofer power switch ON. LED on faceplate should be momentarily Green, then Orange.
- 7) Turn LEVEL control full clockwise (MAX); immediate and vigorous bass response should be heard and felt from main woofer at front of cabinet.
- 8) Turn off generator, turn LEVEL control full counterclockwise (MIN), and disconnect RCA cable.

General Unit Function (Direct connection - No Transmitter)

- 9) From a mono output signal generator, OFF at this time, connect an RCA cable to the L/R jacks on the PSW310W Subwoofer; Use a Y-cable to connect to both inputs; power switch should be OFF.
- 10) PHASE switch position does not matter. CROSSOVER control should be set at "150Hz". Low Pass switch position does not matter. RABOS On/Off switch should be OFF.
- 11) Turn the LEVEL control on the UUT to completely counterclockwise (MIN).
- 12) Turn on signal generator; adjust to **125mV, 50 Hz**.
- 13) Turn the power switch ON. LED on top of Subwoofer should be momentarily Red, then Green.
- 14) Turn LEVEL control full clockwise (MAX); immediate and vigorous bass response should be heard and felt from port tube opening on the bottom.
- 15) Turn off generator, turn LEVEL control full counterclockwise (MIN), and disconnect RCA cable.

Sweep Function

- 1) Follow steps 9-14 above, using a sweep generator as a signal source.
- 2) Sweep generator from 20Hz to 300Hz. Listen to the cabinet and drivers for any rattles, clicks, buzzes or any other noises. If any unusual noises are heard, remove woofer and test.

Driver Function

- 1) Remove woofer from cabinet; detach + and - wire clips.
- 2) Check DC resistance of woofer; it should be **3.4 ohms ±10%**
- 3) Connect a pair of speaker cables to driver terminals. Cables should be connected to an integrated amplifier fed by a signal generator. Turn on generator and adjust so that speaker level output is **5.0V**.
- 4) Sweep generator from 20Hz to 1kHz. Listen to driver for any rubbing, buzzing, or other unusual noises.

PSW310W subwoofer Classia Series

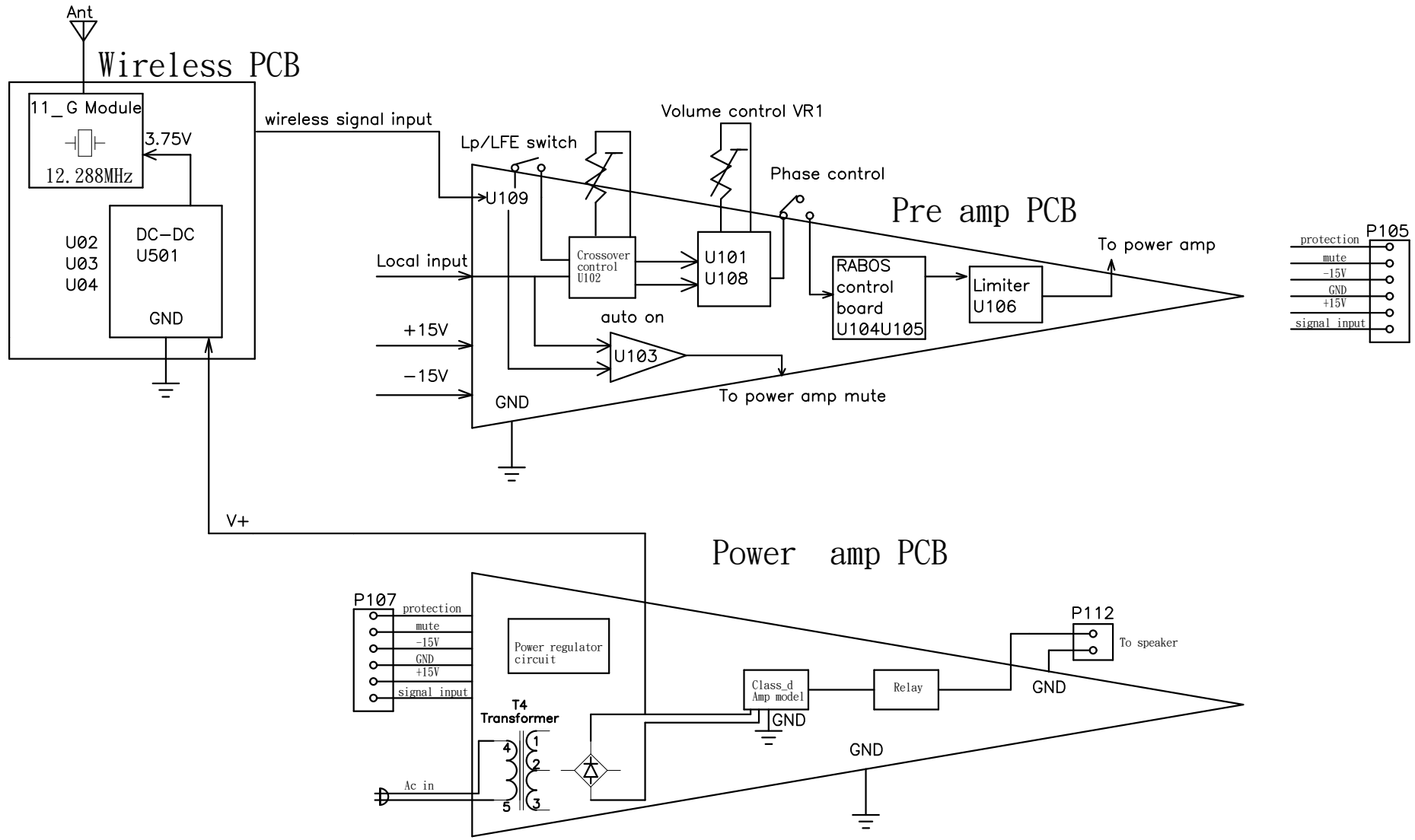

Draw.

Dsgn.

Apvd.

Filename	Rev
Model No. PSW310W-block	1
Drawn by 13	2
Date	3

Size A4

PSW310W Test Flow Chart

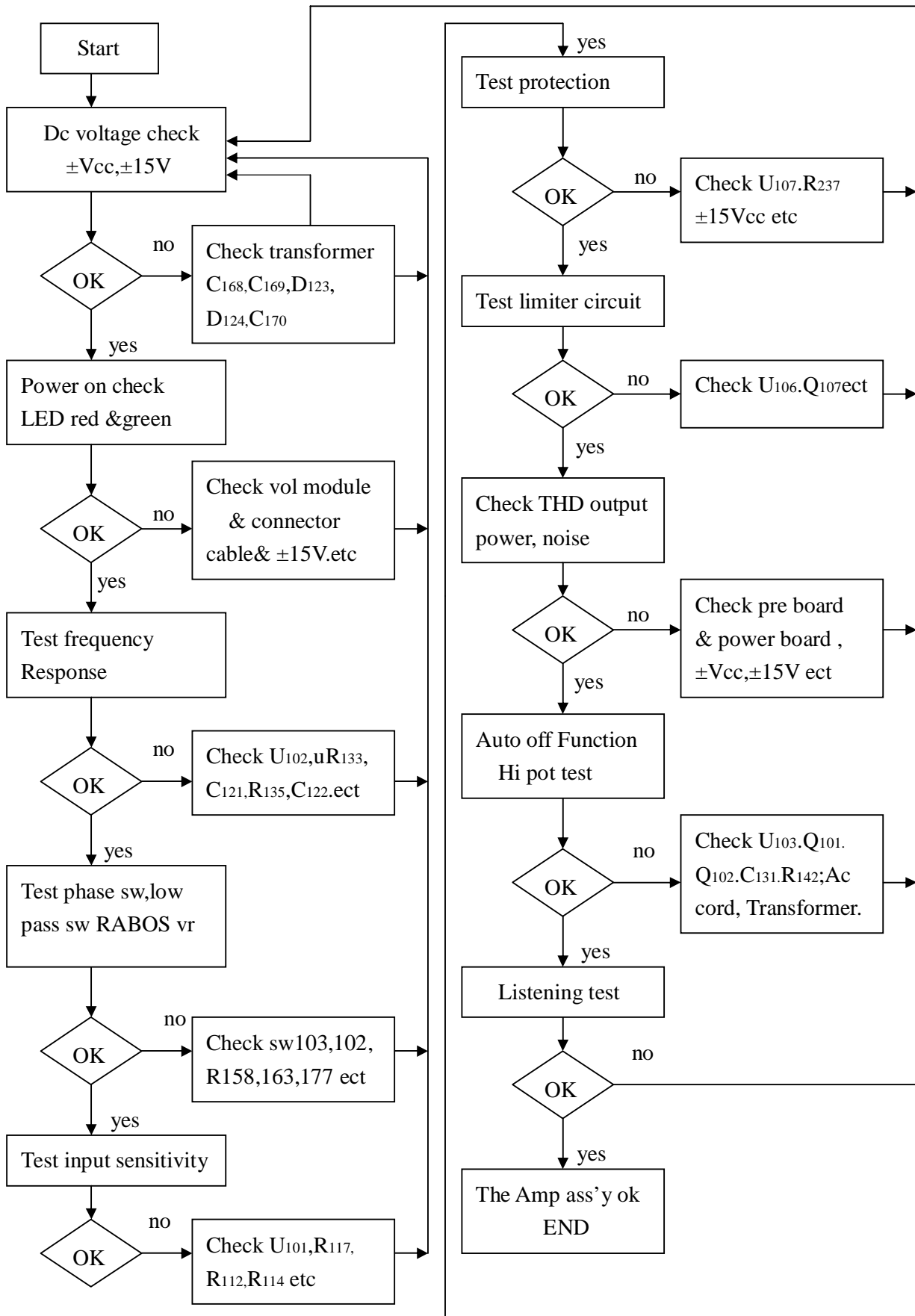

Transmitter

Troubleshooting Flow Chart

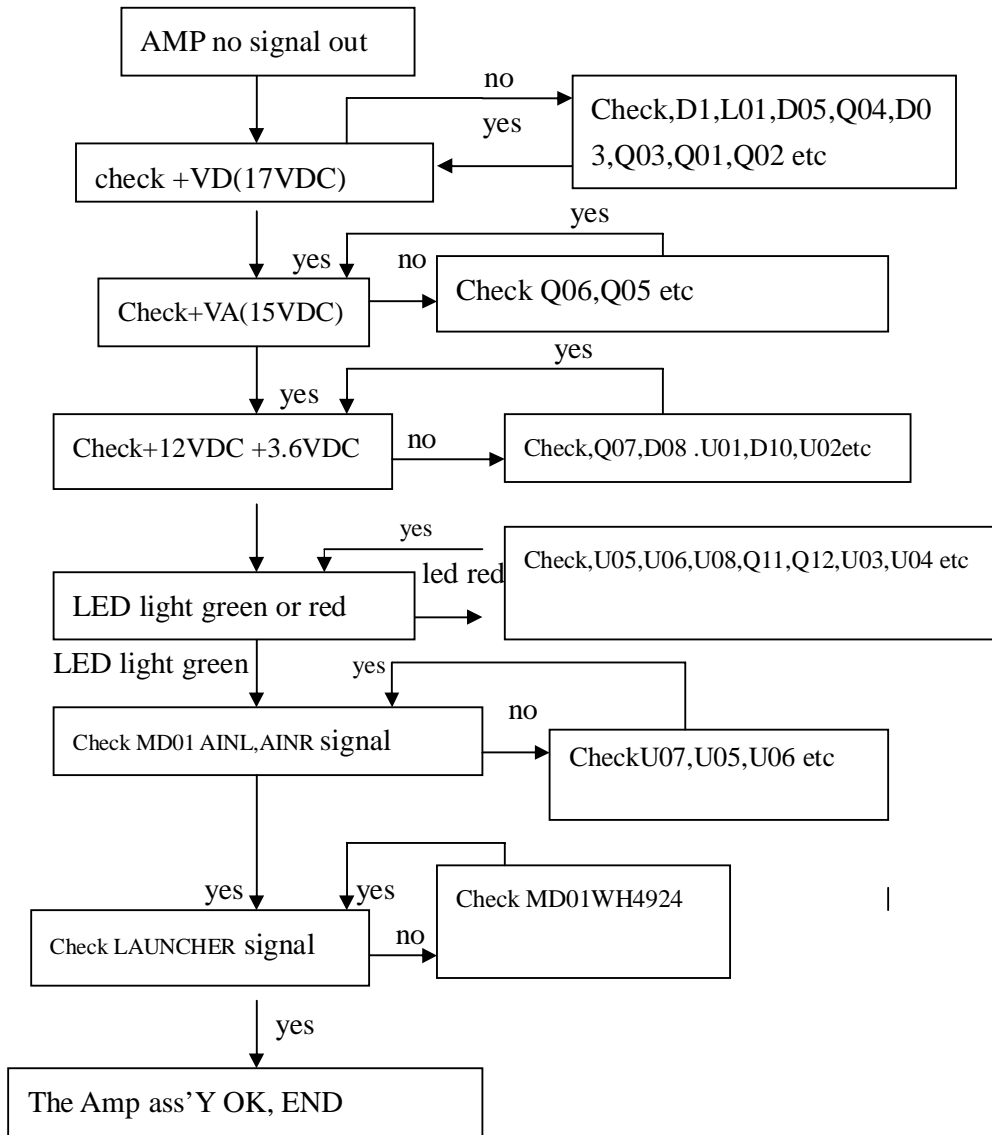

Wireless Receiver board Troubleshooting Flow Chart

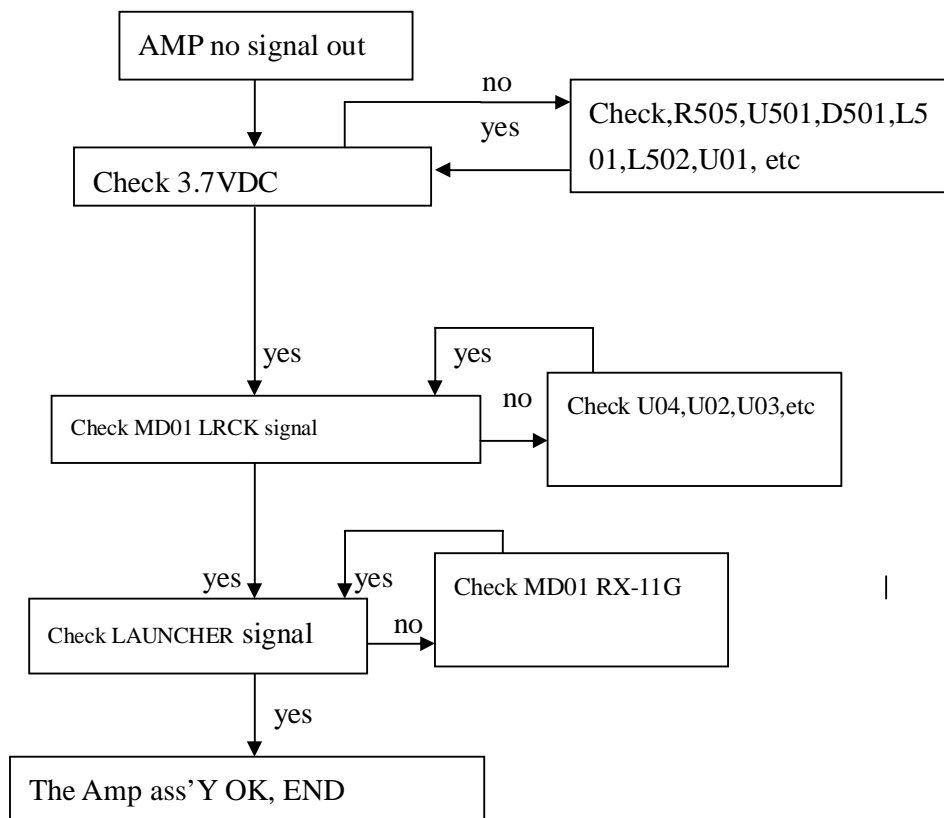

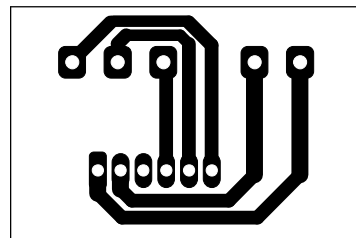
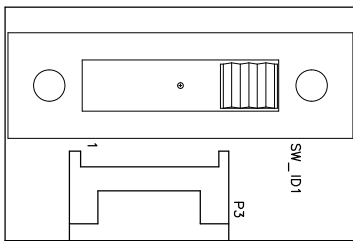
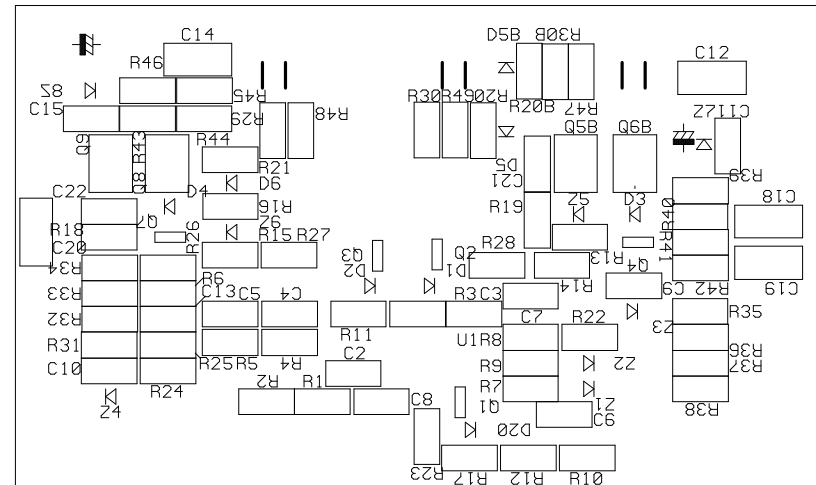
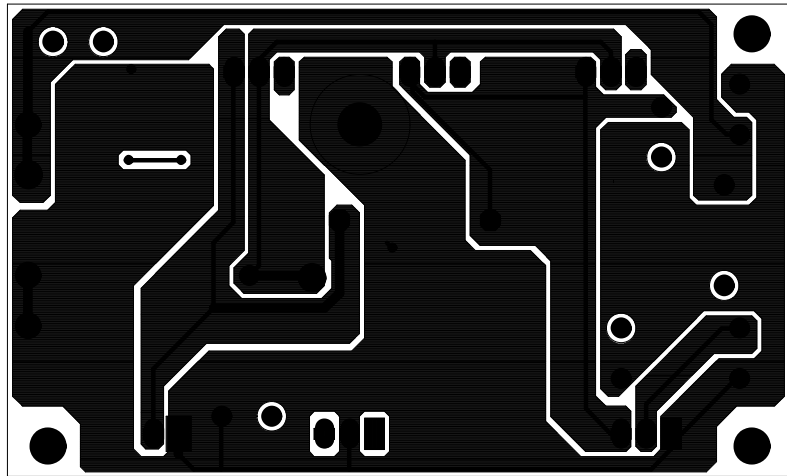
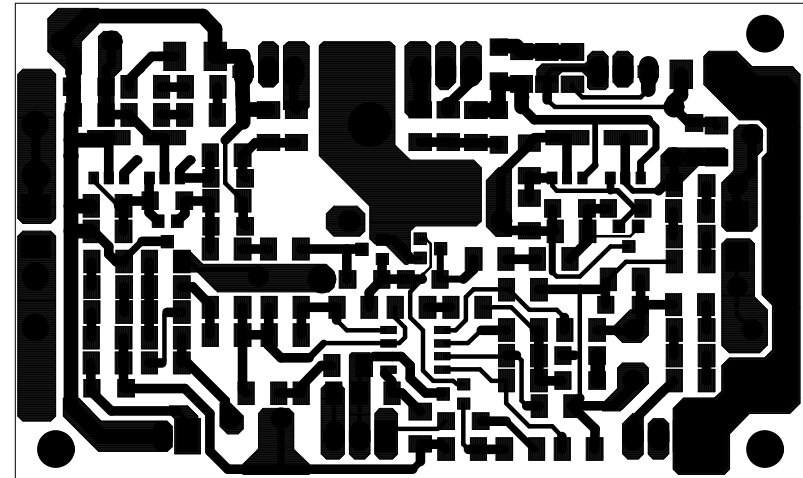
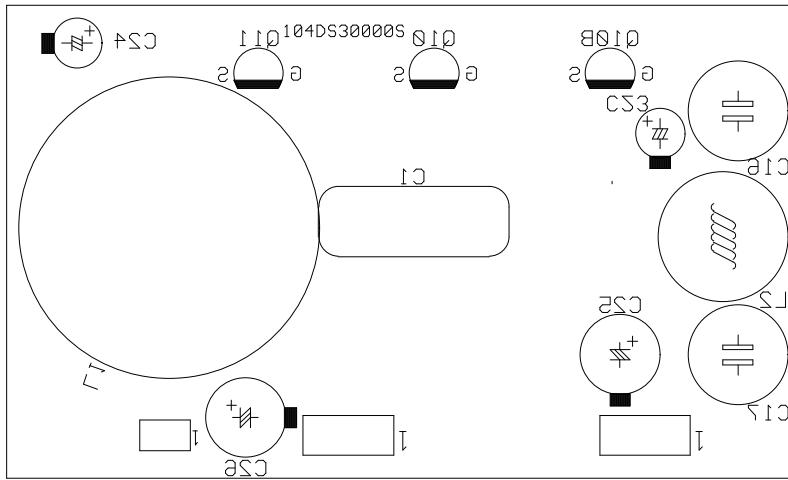

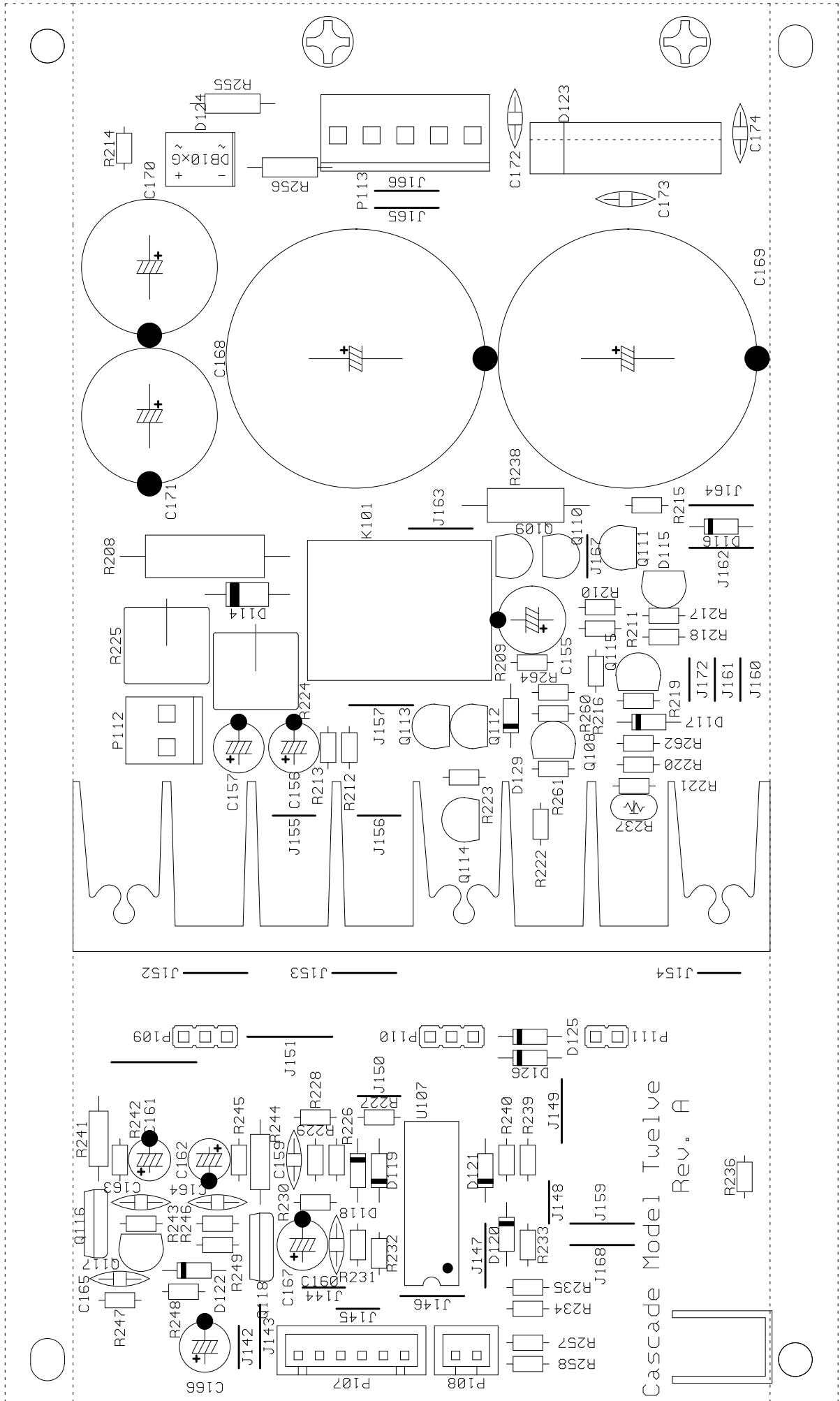

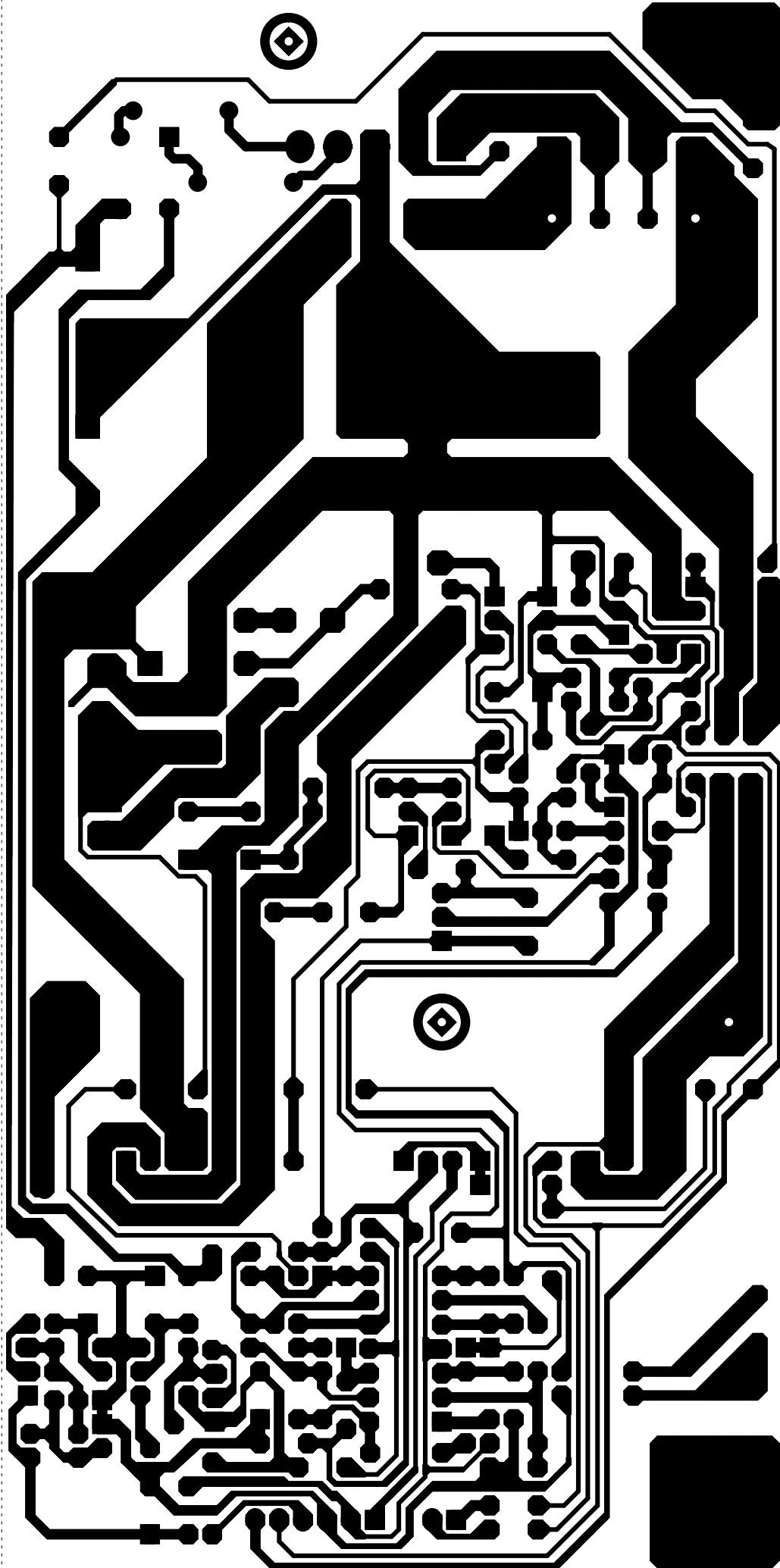

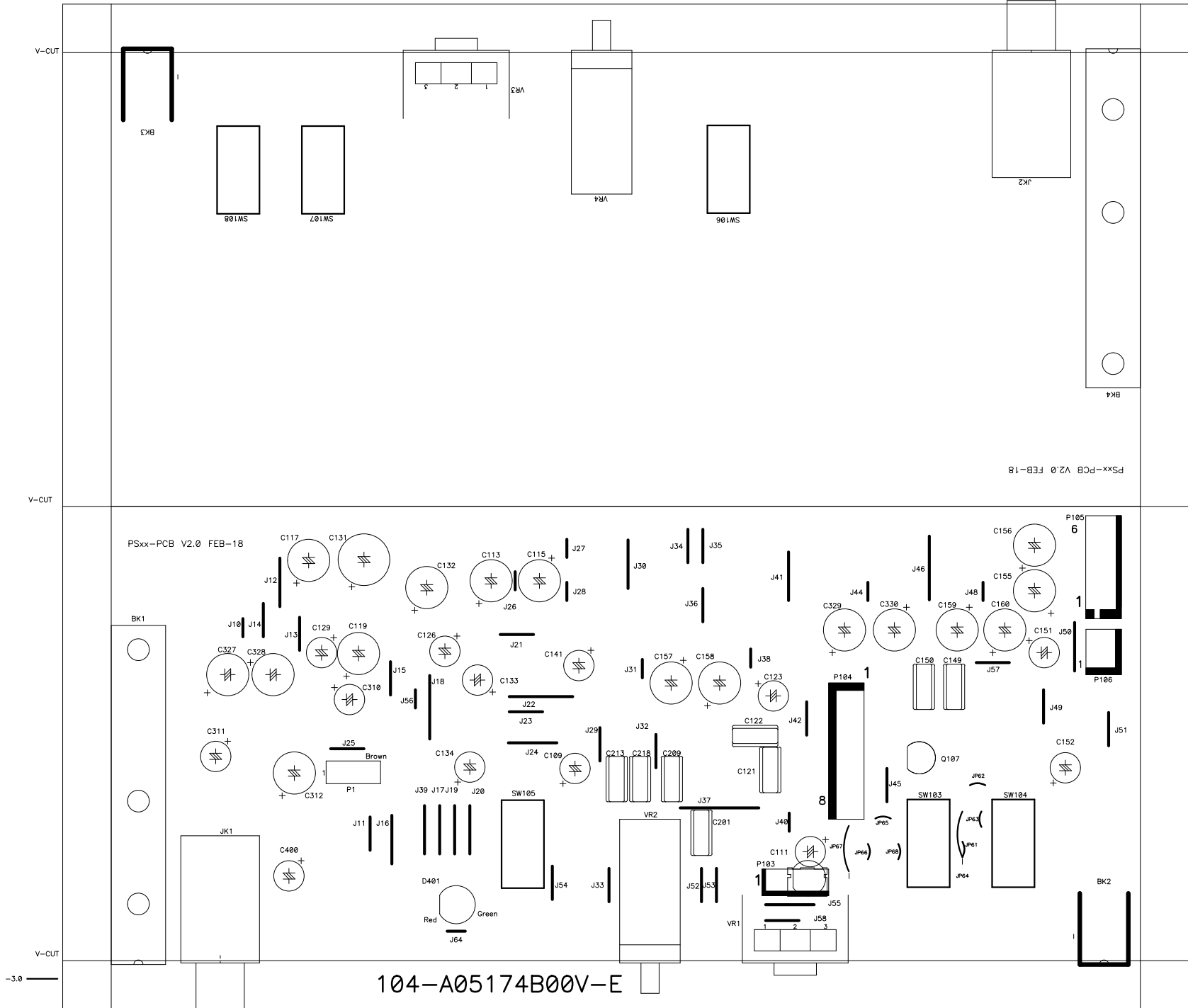

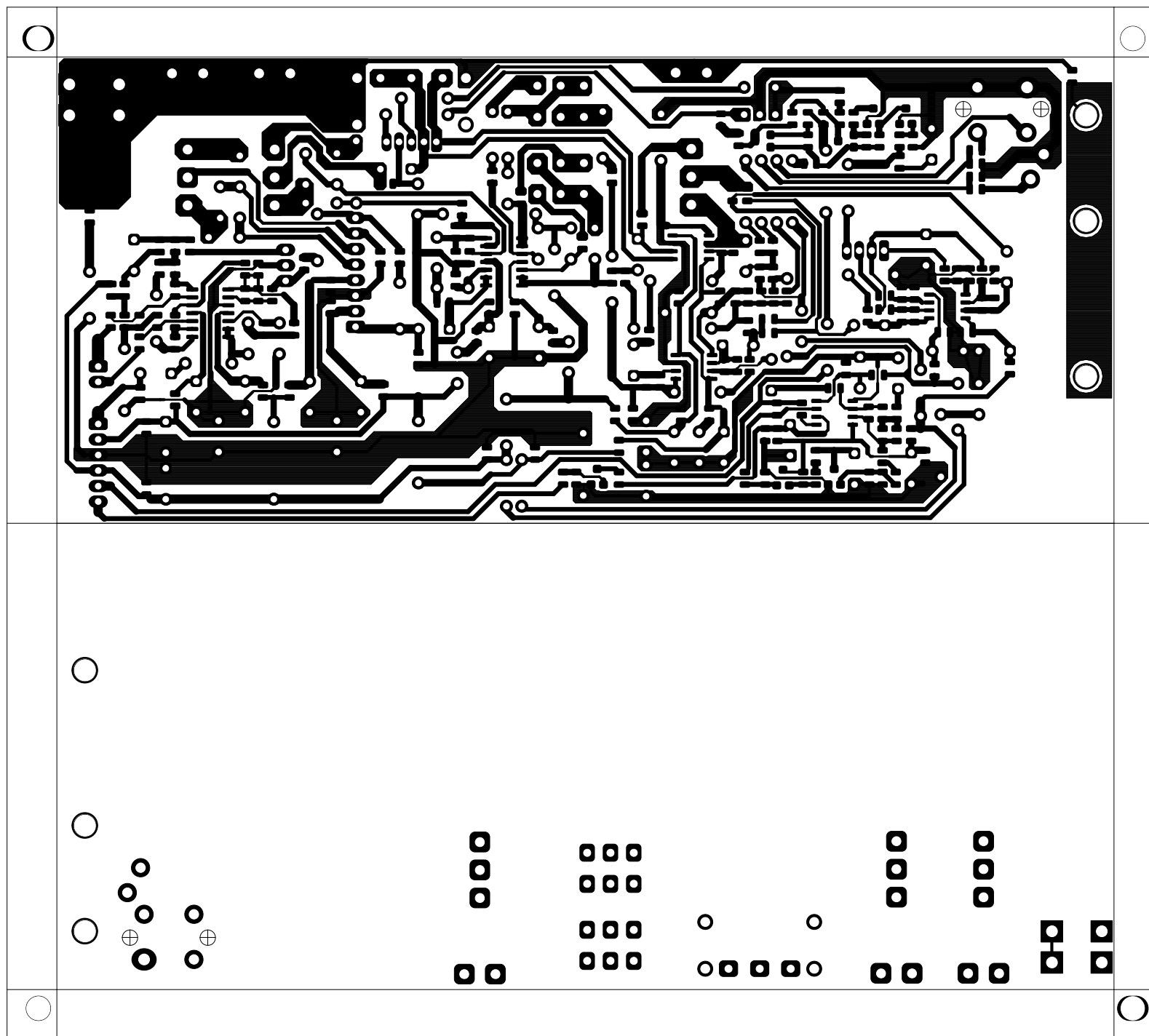

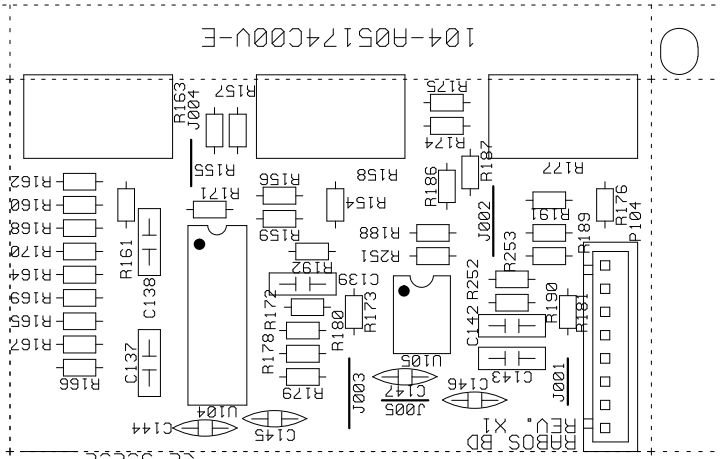
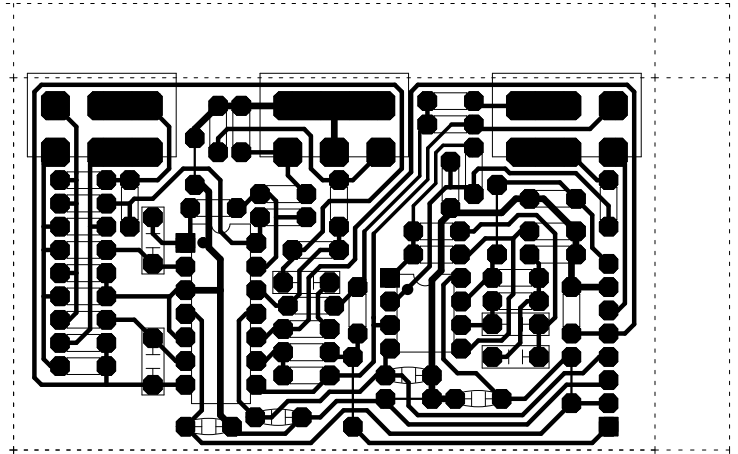

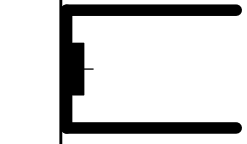

BK04

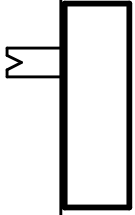

SW02



BK03

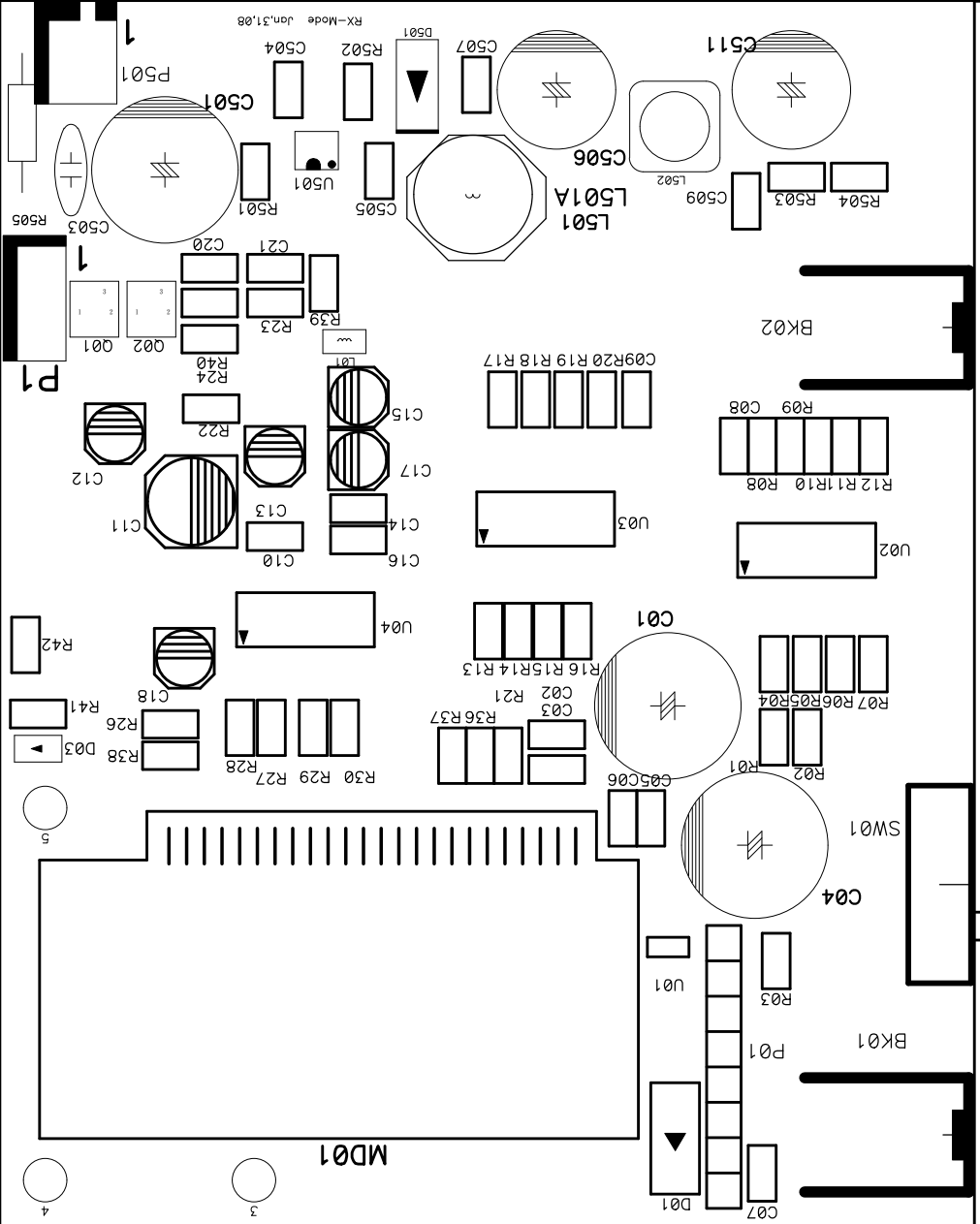

104-A05174D00V-E

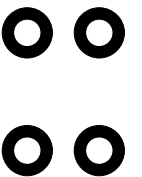
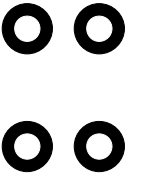
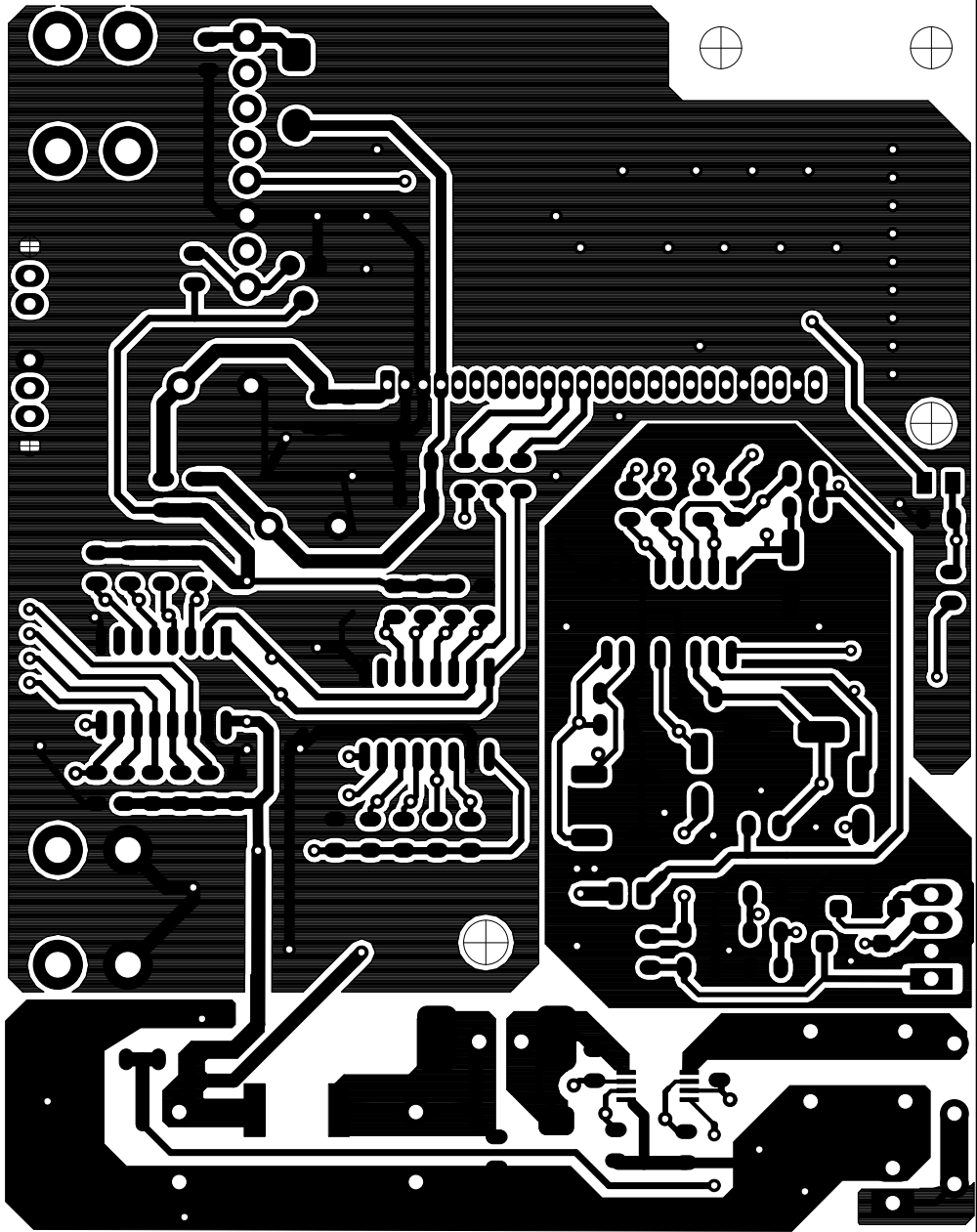

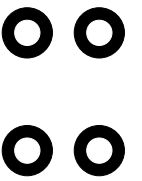
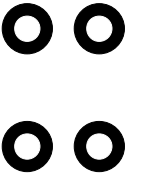
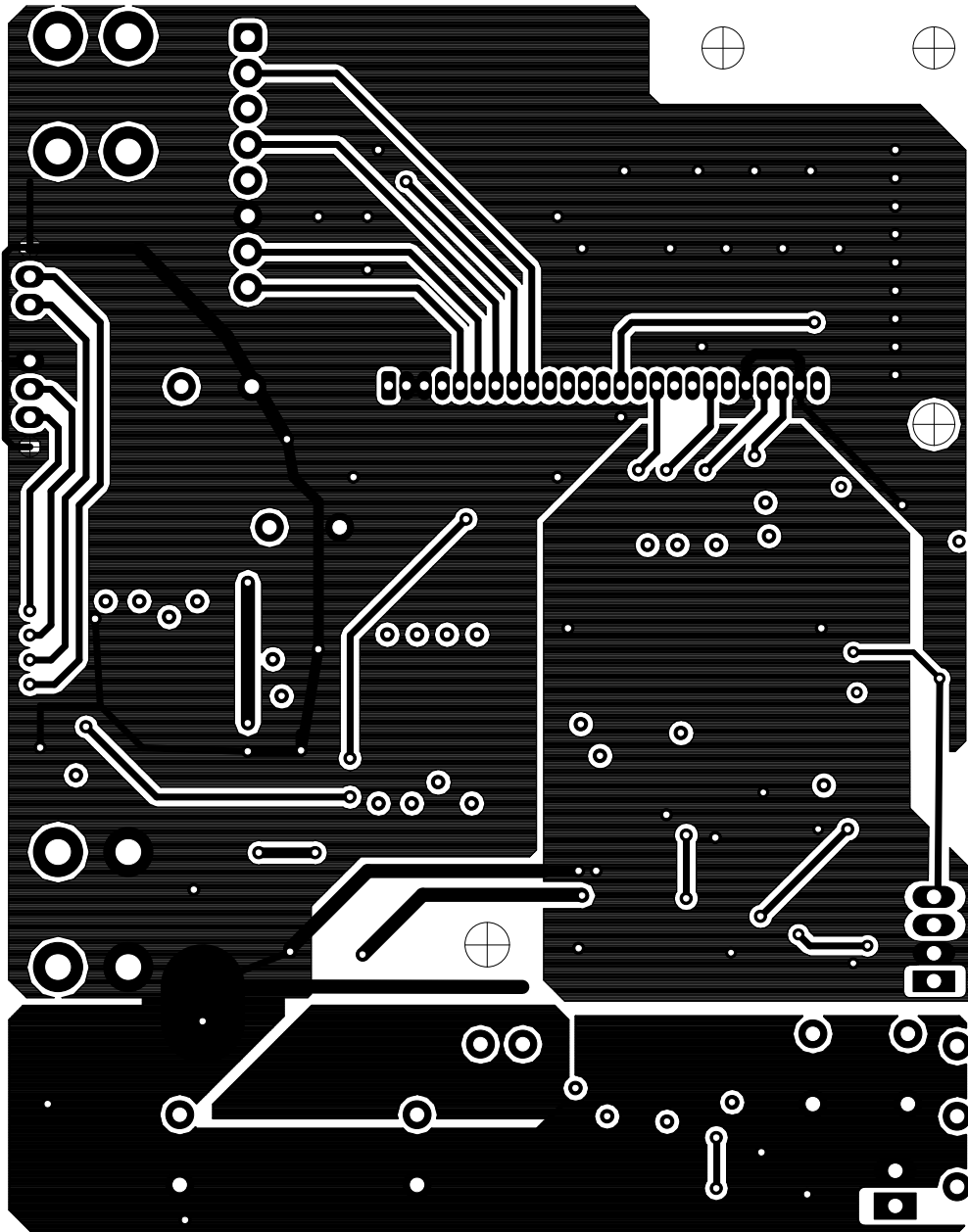

PSW310W (120v) Electrical Parts List			
Part Number	Description	Qty	Reference Designator
MAIN/POWER SUPPLY PCB			
<i>Resistors</i>			
109-1TSC103J0-E	Resistor TSC05103J 10K +/-5% (RoHS)	1	R237,
110-12621J15-E	Resistor 620Ω 1/2W ±5% 15mm(RoHS)	1	R238,
110-20152J20-E	Resistor 1.5K 2W ±5% CF 20mm KINK(RoHS)	1	R208,
113-50R10J10-E	Resistor 0.1Ω 5W ±5% (RoHS)	2	R224,R225,
116-142003F26-E	Resistor 200K 1/4W ±1% MF26mm (RoHS)	1	R209,
110-16103J26-E	Resistor 10K 1/6W ±5% CF 26mm (RoHS)	9	R216,R227,R229,R230,R231,R232,R233,R260,R261,
110-16153J26-E	Resistor 15K 1/6W ±5% CF 26mm (RoHS)	2	R247,R249,
110-16182J26-E	Resistor 1.8K 1/6W ±5% CF 26mm(RoHS)	1	R248,
110-16222J26-E	Resistor 2.2K 1/6W ±5% CF 26mm(RoHS)	2	R242,R245,
110-16223J26-E	Resistor 22K 1/6W ±5% CF 26mm(RoHS)	3	R218,R220,R223,
110-16274J26-E	Resistor 270K 1/6W ±5% CF 26mm(RoHS)	1	R240,
110-16333J26-E	Resistor 33K 1/6W ±5% CF 26mm (RoHS)	1	R211,
110-16391J26-E	Resistor 390Ω 1/6W CF 26mm (RoHS)	2	R243,R246,
110-16472J26-E	Resistor 4.7K 1/6W ±5% CF 26mm (RoHS)	4	R213,R217,R219,R222,
110-16473J26-E	Resistor 47K 1/6W ±5% CF 26mm (RoHS)	1	R221,
110-16683J26-E	Resistor 68K 1/6W ±5% CF 26mm (RoHS)	1	R212,
112-14101J26-E	Resistor 1/4W100ohm 5% (RoHS)	2	R241,R244,
116-141R00J26X-E	Resistor 1.00Ω 1/4W±5% MO 26mm	2	R255,R256,
116-161002F26-E	Resistor 10K 1/6W ±1% MF 26mm (RoHS)	2	R234,R235,
116-161301F26-E	Resistor1.30K 1/6W MF 26mm (RoHS)	3	R226,R228,R236,
116-161692F26-E	Resistor16.9K 1/6W MF 26mm (RoHS)	1	R214,
116-162001F26-E	Resistor 2.00K 1/6W ±1% MF26mm (RoHS)	1	R215,
116-162492F26-E	Resistor 24.9K 1/6W ±1% MF26mm (RoHS)	2	R257,R258,
116-166813F26-E	Resistor 681K 1/6W ±1% MF26mm (RoHS)	1	R262,
110-16102J26-E	Resistor 1K 1/6W ±5% CF 26mm (RoHS)	3	R210,R239,R264
140-RX103KA03-E	Resistor 10nF 100V X7R 10% (RoHS)	1	C174,
<i>Capacitors</i>			
130-3F104ZA03-E	Capacitor 0.1U 100V (RoHS)	2	C168A,C169A
135-4228M35-E	Capacitor 2200uF 35V ±20%(RoHS)	2	C170,C171,
135-4688M80-E	Capacitor 6800U 80V ±20%(RoHS)	2	C168,C169,
130-2b102k503-e	Capacitor 1000P 50V ±10% (RoHS)	1	C165,
130-3F104Z503-E	Capacitor 0.1U 50V +80/-20% (RoHS)	2	C163,C164,
130-CH101J503-E	Capacitor 100P 50V ±5% (RoHS)	2	C159,C160,
135-3107M16-E	Capacitor 100uF 16V ±20% (RoHS)	2	C166,C167,
135-3226M50-E	Capacitor 22U 50V ±20% (RoHS)	2	C161,C162,
135-3227M10-E	Capacitor 220U 10V ±20% (RoHS)	2	C156,C157,
139-3227M16-E	Capacitor 220uF 16V±20% (RoHS)	1	C155,
140-RX473KB53-E	Capacitor47NF 250V X7R±10% (RoHS)	2	C172,C173,
<i>Semiconductors</i>			
190-16LM324N-E	I.C. LM324N (RoHS) QUAD OP-AMP	1	U107,
192-991d669a-e	transistor HI-SINCERITY HSD669A (RoHS) NPN	1	Q116,
192-992B649T-E	transistor HSB649T (RoHS) PNP	1	Q118,
197-00DB103G-E	Rectifier 1A 200V DF02MDB103G (RoHS)		D124,
197-00KBU1003-E	Rectifier 10A 200V KBU1003(RoHS)	1	D123,
197-101N4002-E	Diode 1N4002TB (RoHS)	1	D114,
190-16L431CLP1-E	IC TL431CLP (RoHS) PROGRAMMABLE VOLTAGE REFERENCE	1	D115,
192-027C1815GR-E	transistor 2SC1815GR TOSHIBA(RoHS) NPN	4	Q110,Q112,Q114,Q117,
192-028A1015GR-E	transistor 2SA1015GR TOSHIBA(RoHS) PNP	3	Q111,Q113,Q115,
192-1572N5551-E	transistor FSC 2N5551 (RoHS) NPN	1	Q109,
192-1582N5401-E	Transistor FSC 2N5401 AI-PNP 350V500mA TO-92 (RoH	1	Q108,
197-631N4148-E	Diode 500mW 75V 1N4148 Panjit (RoHS)	7	D117,D118,D119,D120,D121,D125,D126
199-65000563G-E	Diode GDZJ5.6B 500mW 5.6V26mm 2% (RoHS)	1	D116,
199-65001503G-E	Diode GDZJ15C500mW 15V 2% 52mm 1N5245B (RoHS)	1	D122,
199-65002003G-E	Diode GDZJ20D 500mW 20V26mm 2% (RoHS)	1	D129,
<i>Miscellaneous</i>			
120-1000003-E	Inductor 10W AI YT-C3104-0051CRHW354708LTBS LF	2	J161,J165,
171-UDHSS124D-E	Relay 5A 24V UDH-SS124D(RoHS)	1	K101,
175-1C02V01-E	Connector 2PIN PITCH=2.5mm (RoHS)	1	P108,
175-1c06v01-e	Connector 6 PIN PITCH=2.5mm(RoHS)	1	P107,

Part Number	Description	Qty	Reference Designator
MAIN/POWER SUPPLY PCB			
175-1d02v01-e	Connector 2PIN PITCH=3.96mm(RoHS)	1	P112,
175-1d05v01-e	Connector 5PIN 3.96mm (RoHS)	1	P113,
362-FE-00041-0LAE	PCB stand 11.75*8.5*12.5H(RoHS)	1	
INPUT/PREAMP PCB			
<i>Resistors</i>			
118-0805000J-E	SMD Resistor 0805 1/10W 0Ω±5%LF	2	JP1,JP3,
118-08051000F-E	SMD Resistor 0805 1/10W 100 ±1% LF	6	R314,R315,R125,R151,R152,R215,
118-08051001F-E	SMD Resistor 0805 1/10W 1K ±1% LF	2	R140,R194,
118-08051001J-E	SMD Resistor 0805 1/10W 1K ±5% LF	5	R400,R401,R405,R406,R410,
118-08051002F-E	SMD Resistor 10.0K 0805 1/10W 1%(RoHS)	16	R330,R331,R111,R118,R122,R124,R133,R136,R146,R149 R308,R130,R131,R132,R199,R263,
118-08051002J-E	SMD Resistor 0805 1/10W 10KΩ ±5%LF	2	R402,R403,
118-08051004J-E	SMD Resistor 1M 0805 1/10W 5%(RoHS)	1	R145,
118-08051201J-E	SMD Resistor 1.2K 0805 1/10W 5%(RoHS)	1	R409,
118-08051500F-E	SMD Resistor 0805 150ohm 1% (RoHS)	1	R139,
118-08051504J-E	SMD Resistor 1.5M 0805 1/10W 5%(RoHS)	1	R142,
118-08051693F-E	SMD Resistor169K 0805 1/10W 1%(RoHS)	1	R195,
118-08051802J-E	SMD Resistor 18K 0805 1/10W 5%(RoHS)	1	R147,
118-08052001F-E	SMD Resistor 0.1W 1% 2K (RoHS)	1	R202,
118-08052002F-E	SMD Resistor 0805 20.0K 1% (RoHS)	1	R200,
118-08052052F-E	SMD Resistor20.5K 0805 1/10W 1%(RoHS)	2	R197,R198,
118-08052200J-E	SMD Resistor 0805 1/10W 220Ω 5%(RoHS)	11	R411,R332,R333,R119,R120,R154A,R155A,R159A,R160A R334,R335,
118-08052202F-E	SMD Resistor 0805 1/10W 22K±1%(RoHS)	2	R141,R148,
118-08052202J-E	SMD Resistor 0805 1/10W 22KΩ ±5%LF	1	R404,
118-08052212F-E	SMD Resistor 0805 22.1K 1% (RoHS)	3	R193,R204,R206,
118-08052262F-E	SMD Resistor 0805 22.6K 1% (RoHS)	4	R209,R296,R297,R298,
118-08052402F-E	SMD Resistor 24K 0805 1% (RoHS)	1	R117,
118-08053301J-E	SMD Resistor 0805 1/10W 3.3K ±5%(RoHS)	1	R407,
118-08053401F-E	SMD Resistor 3.4K 0805 1/10W 1%(RoHS)	1	R128,
118-08053923F-E	SMD Resistor392K 0805 1/10W 1%(RoHS)	1	R208,
118-08054301F-E	SMD Resistor 0.1W 1% 4.3K(RoHS)	1	R254,
118-08054320F-E	SMD Resistor432Ω 0805 1/10W 1%(RoHS)	1	R265,
118-08054421F-E	SMD Resistor 0.1W 1% 4.42K(RoHS)	2	R205,R207,
118-08054701J-E	SMD Resistor 0805 1/10W 4.7K ±5%LF	1	R144,
118-08054702J-E	SMD Resistor 47K 0805 1/10W 5%RoHS	9	R109,R114,R115,R116,R121,R137,R138,R219,R412,
118-08054703J-E	SMD Resistor 470K 0805 1/10W 5%(RoHS)	1	R143,
118-08054R70J-E	SMD Resistor 4R7 0805 1/10W 5%(RoHS)	1	R153,
118-08055101F-E	SMD Resistor 5.1K 0805 1/10W 1%(RoHS)	8	R316,R317,R318,R319,R320,R321,R322,R323,
118-08056801F-E	SMD Resistor 6.8K 0805 1/10W 1%(RoHS)	6	R300,R301,R110,R112,R113,R123,
118-08056812F-E	SMD Resistor 0805 68.1K 1% (RoHS)	1	R135,
118-08058061F-E	SMD Resistor8.06K 0805 1/10W 1%(RoHS)	1	R134,
115-H203A106-E	Variable Resistor A20K (RoHS) LEVEL	1	VR1,
115-H503B405-E	Variable Resistor B50K (RoHS) CROSSOVER	1	VR2,
<i>Capacitors</i>			
141-B0101J50-E	CAP CERAMIC/CHIP 100PF 50V CHJNPO 0805 RoHS	6	C318,C319,C331,C332,C110B,C148,
141-B0221J50-E	SMD Cer capacitor 220P 50V NPO 0805(RoHS)	3	C304,C305,C212,
141-B0470J50-E	SMD Cer capacitor 47pF 0805 NPO 50V(RoHS)	1	C128,
141-B0680J50-E	SMD Cer capacitor 68pF 0805 NPO 50VRoHS	1	C127,
141-B5104Z50-E	Cer capacitor CAP SMD 0805 Y5V0.1uF +80/-20% 50V L	19	C320,C322,C112,C114,C116,C118,C124,C125,C130,C232 C233,C153,C154,C184,C185,C206,C205,C144,C145,
141-B7102J50-E	SMD Cer capacitor 0805 X7R 1nF 50V5% (RoHS)	2	C181,C182,
141-B7272K50-E	SMD Cer capacitor0805 2700PF 50V X7R(RoHS)	1	C110,
141-B7332J50-E	SMD Cer capacitor 0805 X7R 3300pF 5%(RoHS)	2	C120,C317,
141-B7472J50-E	SMD capacitor 0805 X7R 4700PF 5% 50V(RoHS)	1	C110A,
129-A223J633-E	Capacitor 0.022U 63V ±5% MSC (RoHS)	1	C150,
129-A224J633-E	Capacitor 0.22uF 63V ±5% MSC(RoHS)	2	C121,C122,
129-A333J633-E	Capacitor 0.033U 63V MSC (RoHS)	2	C209,C218,
129-A473J633-E	Capacitor 0.047U 63V ±5% MSC (RoHS)	1	C149,
129-A683J633-E	Capacitor 0.068U 63V ±5% MSC RoHS	2	C201,C213,
135-3106M25-E	Capacitor 10uF 25V ±20% (RoHA)	10	C310,C311,C109,C111,C123,C126,C129,C133,C134,C141
135-3107M16-E	Capacitor 100uF 16V ±20% (RoHS)	16	C152,C159,C160,C327,C328,C155,C156,C113,C115,C117 C119,C132,C157,C158,C329,C330,
135-3226M25-E	Capacitor 85°C 22uF ±20%25V LF	2	C312,C151,

Part Number	Description	Qty	Reference Designator
INPUT/PREAMP PCB			
139-3227M16-E	Capacitor 220uF 16V±20% (RoHS)	1	C131,
<i>Semiconductors</i>			
190-16TL072DTS-E	I.C. TL072N @6.5 (RoHS) DUAL OP-AMP	4	U109,U101,U103,U108,
190-16TL074CDS-E	I.C TL074CN ST (RoHS) QUAD OP-AMP	2	U102,U106,
192-027C1815GRS-E	SMT Transistor MMBT1815 SOT-23(RoHS)	5	Q402,Q403,Q101,Q102,Q103,
192-998A1015GRS-E	SMD Transistor MMBT1015 CJ SOT-23(RoHS)	2	Q400,Q401,
197-0S4148WSP-E	SMD Diode LL4148WSP 0805SHAWELL	10	D400,D108,D109,D110,D207,D208,D303,D304,D112,D113
199-6200082D-E	Diode 8.2V BZT52-C8V2SSOD-323(RoHS)	1	D130,
192-153MPF102-E	Transistor FAIRCHILD MPF102 (RoHS)TO-92	1	Q107,
<i>Miscellaneous</i>			
162-10169003-E	Wire 160mm AWG28 (RoHS)	1	P105,
162-8008D001-E	Wire 80mm 4pin P=2.0mm(RoHS)	1	P1,
162-A013D001-E	WIRE UL1007#28 130mm (RoHS)	1	P104,
174-ORCA313G-E	RCA Jack RCA-313G (RoHS)	1	JK1,
175-1C02V01-E	Connector 2PIN PITCH=2.5mm (RoHS)	1	P106,
180-T000TS81-E	TACT Switch L101 T2 T8019L-SNQ-E-H+U RoHS	3	SW103,SW104,SW105,
362-FE-00041-0LAE	PCB stand 11.75*8.5*12.5H(RoHS)	1	BK2,
RABOS PCB			
<i>Resistors</i>			
115-H103A203-E	Variable Resistor RV16A01-20-15K-A10K-3E (RoHS) LEVEL, WIDTH	2	R158,R177
115-H103C201-E	Variable Resistor RV16A01-20-15K-C10K-3E (RoHS) FR	1	R163
110-16105J26-E	Resistor 1M 1/6W ±5% CF 26mm (RoHS)	1	R181,
110-16106J26-E	Resistor 10M 1/6W ±5% CF 26mm (RoHS)	1	R186,
116-161000F26-E	Resistor 100Ω 1/6W ±1% MF26mm (RoHS)	1	R154,
116-161001F26-E	Resistor 1K 1/6W ±1% MF26mm (RoHS)	3	R180,R187,R252,
116-161002F26-E	Resistor 10K 1/6W ±1% MF 26mm (RoHS)	7	R159,R160,R171,R173,R178,R192,R166,
116-161103F26-E	Resistor 110K ±1% MF 1/6W26mm (RoHS)	1	R174,
116-161502F26-E	Resistor 15.0K 1/6W ±1% MF26mm (RoHS)	2	R162,R168,
116-161652F26-E	Resistor 16.5K 1/6W ±1% MF26mm (RoHS)	1	R188,
116-162051F26-E	Resistor 2.05K 1/6W MF 26mm (RoHS)	1	R253,
116-162211F26-E	Resistor 2.21K 1/6W ±1% MF26mm (RoHS)	1	R172,
116-162671F26-E	Resistor 2.67K 1/6W ±1% MF26mm (RoHS)	1	R155,
116-163161F26-E	Resistor3.16K 1/6W±1% MF 26mm (RoHS)	1	R251,
116-163400F26-E	Resistor 340Ω 1/6W ±1% MF26mm (RoHS)	2	R164,R169,
116-163571F26-E	Resistor 3.57K 1/6W 1% MF 26mm (RoHS)	1	R157,
116-165400F26-E	Resistor540Ω 1/6W MF 26mm (RoHS)	1	R175
116-166041F26-E	Resistor 6.04K 1/6W ±1% MF 26mm (RoHS)	2	R165,R170,
116-166341F26-E	Resistor 6.34K±1%MF 1/6W	1	R189,
116-166800F26-E	Resistor 680Ω 1/6W ±1% MF26mm (RoH	1	R176,
116-168250F26-E	Resistor 825Ω 1/6W ±1% MF26mm (RoHS)	2	R161,R167,
116-169092F26-E	Resistor 90.9K 1/6W MF 26mm (RoHS)	1	R190,
116-169311F26-E	Resistor 9.31K 1/6W ±1% MF26mm (RoHS)	1	R179,
<i>Capacitors</i>			
129-A104J633-E	Capacitor 0.1U 63V ±5% MSC (RoHS)	3	C137,C138,C139,
129-A683J633-E	Capacitor 0.068U 63V ±5% MSC RoHS	2	C142,C143,
130-3F104Z503-E	Capacitor 0.1U 50V +80/-20% (RoHS)	4	C144,C145,C146,C147,
<i>Semiconductors</i>			
190-16TL072N-E	I.C. TL072N @6.5 (RoHS) DUAL OP-AMP	1	U105
190-16TL074CN-E	I.C TL074CN ST (RoHS) QUAD OP-AMP	1	U104
<i>Miscellaneous</i>			
175-9C08V01-E	Connector 8PIN PITCH=2.5mm (RoHS)	1	P104

Part Number	Description	Qty	Reference Designator
WIRELESS RECEIVER PCB			
<i>Resistors</i>			
118-08050000J-E	SMD Resistor 0805 1/10W 0Ω±5%LF	8	R21,R27,R28,R29,R30,R36,R37,R22,
118-08051002J-E	SMD Resistor 0805 1/10W 10KΩ ±5%LF	3	R26,R12,R13,
118-08051200F-E	SMD Resistor 120Ω 0805 1% RoHS	1	R503,
118-08052002J-E	SMD Resistor 20K 0805 1/10W 5%(RoHS)	15	R04,R05,R06,R07,R08,R09,R10,R11,R14,R15,R16,R17,R18, R19,R20,
118-08052400F-E	SMD Resistor 240Ω0805 1% ROHS	1	R504,
118-08052703J-E	SMD Resistor 270K 0805 5% (RoHS)	1	R502,
118-08053303J-E	SMD Resistor 330K 0805 5% (RoHS)	1	R501,
118-08054701J-E	SMD Resistor 0805 1/10W 4.7K ±5%LF	1	R38,
118-08054702J-E	SMD Resistor 47K 0805 1/10W 5%(RoHS)	1	R03,
118-08054R70J-E	SMD Resistor 4R7 0805 1/10W 5%(RoHS)	2	R01,R02,
118-080556R0J-E	SMD Resistor 0805 56Ω 1/10W 5%(RoHS)	1	L01,
118-08056200J-E	SMD Resistor 0805 620Ω ±5% (RoHS)	2	R39,R40,
116-1410R0J5VX-E	Resistor 10Ω 1/4W ±5% (RoHS)	1	R505,
<i>Capacitors</i>			
141-B7102J50-E	SMD Cer Capacitor 0805 X7R 1nF 50V5% (RoHS)	1	C06,
141-B7103K50-E	SMD Cer Capacitor 0.01U 50V X7R 0805(RoHS)	2	C03,C505,
141-B7104K50-E	Cer Capacitor CAP SMD 0805 X7R0.1uF ±10% 50V LF/R	10	C02,C05,C08,C09,C10,C14,C16,C504,C507,C509,
141-B7332J50-E	SMD Cer Capacitor 0805 X7R 3300pF 5%(RoHS)	2	C20,C21,
142-AV107M16H-E	SMD capacitor 100UF 16V φ6.3*5.4mm (RoHS)	1	C11,
142-SV105M50H-E	SMD capacitor 1uF 50V 4.3*4.3mm(RoHS)	2	C15,C17,
142-SV106M16H-E	SMD capacitor 10U 16V (RoHS)	3	C12,C13,C18,
130-2B104KA03-E	Cer capacitor 0.1uf 100V 10% (RoHS)	1	C503,
135-3476M100-E	Capacitor 47uF 100V±20% 10*16 5mm (RoHS)	1	C501,
135-3477M16-E	Capacitor 85°C 470uF ±20%16V LF	4	C01,C04,C511,C506,
<i>Semiconductors</i>			
190-145008MMS-E	SMD IC LM5008MM/NOPB(NATIONAL)(RoHS) High Voltage (100V) Step Down Switching Regulator	1	U501,
190-19HCT165S-E	SMD IC 74HC/HCT165(RoHS)PHILIPS 8-bit parallel-in/serial-out shift register	2	U02,U03,
190-99CS4340KS-E	IC CS4340-KS 16Pin SoIC(RoHS) 24-Bit, 96 kHz Stereo DAC	1	U04,
190-99IMP809S-E	SMD IC IMP809SEUR-T(IMP)(RoHS) RESET	1	U01,
197-63S110-E	Diode S100 100V 1A SMAD0-214AC(RoHS)	1	D501,
051-WH4927-E	Wireless HI-FI Audio RX ModuleWH4927 (RoHS)	1	MD01
<i>Miscellaneous</i>			
175-1B04V01A-E	Connector 4PIN PITCH2.0mm (RoHS)	1	P1,
175-1C02V01-E	Connector 2PIN PITCH=2.5mm (RoHS)	1	P501,
175-9B06V03-E	Connector 6Pin PITCH=2.0mm(RoHS)	1	SW01,
175-9Y25V2201-E	PIN HEADER 25PH=1.27mm(RoHS)	1	
333-EVA-05425-0BAE	Gasket EVA 13*10*3MM CONTROL 2.4G (RoHS)	2	
362-FE-00041-0LAE	PCB stand 11.75*8.5*12.5H(RoHS)	2	BK01,BK02,
162-5009D006-E	Wire 90mm P=2.0mm(RoHS)	1	
180-SS14H03GT-E	SLIDE SW SS14H03GT-GP(RoHS) Wireless ID Code 1,2	1	SW01,
121-COMM220M-E	SMD Inductor22UH±20%YC5D18T*220MS(RoHS)	1	L502,
121-COMM221M-E	SMD Inductor220UH±20% YC8D43T*221MS(RoHS)	1	L501,
CLASS D PCB ASS'Y (RECOMMENDED REPLACE ENTIRE MODULE PART# 051-A05022C-E)			
<i>Resistors</i>			
118-12061001F-E	SMD Resistor 1K 1206 1% (RoHS)	1	R2,
118-12061002F-E	SMD Resistor 10K 1206 1% (RoHS)	1	R25,
118-12061002J-E	SMD Resistor 10.0K 1206 5% (RoHS)	5	R29,R30,R30B,R7,R9,
118-120610R0J-E	SMD Resistor 10.0Ω 1206 5% (RoHS)	4	R20,R20B,R22,R23,
118-12062002F-E	SMD Resistor 20K 1206 1% (RoHS)	1	R26,
118-12062201J-E	SMD Resistor 2.20K 1206 5% (RoHS)	18	R13,R16,R31,R33,R34,R35,R36,R37,R38,R39,R40,R41,R42, R43,R44,R45,R46,R32,
118-12062204J-E	SMD Resistor 2.20M 1206 5% (RoHS)	1	R4,
118-12062211F-E	SMD Resistor 2.21K 1206 1% (RoHS)	1	R6,
118-12062550F-E	SMD Resistor 1206 255Ω 1% (RoHS)	1	R24,
118-12062701J-E	SMD Resistor 2.70K 1206 5% (RoHS)	1	R10,

Part Number	Description	Qty	Reference Designator
CLASS D PCB ASS'Y (RECOMMENDED REPLACE ENTIRE MODULE PART# 051-A05022C-E)			
118-12063301J-E	SMD Resistor 3.30K 1206 5% (RoHS)	4	R14,R15,R27,R28,
118-12063321F-E	SMD Resistor 3.32K 1206 1% (RoHS)	1	R1,
118-12063922F-E	SMD Resistor 1206 39.2K±1% (RoHS)	1	R3,
118-12064700J-E	SMD Resistor 470Ω 1206 5% (RoHS)	3	R8,R11,R21,
118-12064701J-E	SMD Resistor 4.7K 5% 1206(RoHS)	1	R12,
118-12064751F-E	SMD Resistor 4.75K 1206 1% (RoHS)	1	R5,
112-10180J00-E	Fuse resistor FMF 1W 18Ω 5%(RoHS)	1	R47
<i>Capacitors</i>			
141-C0101K50-E	SMD Cer capacitor 100pF 50V 10%1206 NP0 (RoHS)	1	C4,
141-C0220K50-E	SMD Cer capacitor 22pF 50V 10% 1206SMT NPO (RoHS)	1	C5,
141-C0561K50-E	SMD Cer capacitor 560pF 50V 10%1206 NPO (RoHS)	1	C6,
141-C5104M50-E	SMD Cer capacitor 1206 Y5V 0.1uF50V ±20% (RoHS)	8	C2,C3,C7,C8,C9,C10,C11,C15,
141-C7103K50-E	SMD Cer capacitor 10nF 50V 1%1206 X7R (RoHS)	1	C13,
141-D7104KB5-E	SMD Cer capacitor 0.1uF 250V 10%1210 X7R (RoHS)	2	C18,C19,
128-E106MA01-SE	Capacitor 10uF 100V 20%(RoHS)	2	C16,C17,
129-A104JA03-E	Capacitor 0.1U 100V ±5% MSC (RoHS)	2	C12B,C14,
130-SL681KB03-E	Capacitor SL 680PF 200V (RoHS)	1	C21
132-104KB50-E	Capacitor 0.1U ±10% 250V (RoHS)	1	C20,
132-105KB50-E	Capacitor 1uF 250V ±10% (RoHS)	1	C40,
<i>Semiconductors</i>			
192-1582N5401-E	Transistor FSC 2N5401 AI-PNP 350V500mA TO-92 (RoH	1	Q6B,
192-232IRF9640-E	FET IRF9640 IR P-CH TO220(RoHS)	2	Q10,Q10B,
192-233F640N-E	Transistor IRF640N INTERNATIONAL(RoHS)	1	Q11,
190-16t072dts-e	SMD I.C. TL072CDT SGS THOMSON(RoHS) DUAL OP-AMP	1	IC1,
192-09124126qs-e	SMD Transistor 2SC2412K-T146Q/RROHM (RoHS)	2	Q1,Q4,
192-09139066rs-e	SMD Transistor 2SC3906K-T146R ROHM(RoHS)	2	Q2,Q8,
192-091SC4672-E	Transistor 2SC4672(MPT3) ROHM(RoHS)	1	Q5B,
192-09210376qs-e	SMD Transistor 2SA1037K-T146Q/RROHM (RoHS)	2	Q7,Q9,
192-09215146rs-e	SMD Transistor 2SA1514K-T146R ROHM(RoHS)	1	Q3,
197-03r1s4148s-e	*SMD diode RLS4148-TE11 ROHM(RoHS)	8	D1,D2,D3,D4,D5,D5B,D6,D20,
199-15000563S-E	SMD ZENER 5.6V 5% PHILIPSBZX84-C5V6(RoHS)	2	Z1,Z2,
199-1500120s-e	SMD ZENER 12V 5% PHILIPSBZX84-C12 (RoHS)	4	Z3,Z4,Z5,Z6,
<i>Miscellaneous</i>			
122-13151K0190-E	CHOKE SA-500-280(PT1601B*151MAA) (RoHS)	1	L1,
122-14300K4-E	Ferrite core LD1215*300KU±10% RoHS	1	L2,
175-9F02H02-E	Connector 2PIN PITCH=2.54mm(RoHS)	1	HDR3,
175-9F03H020-E	Connector 3PIN PITCH=2.54mm(RoHS)	2	HDR1,HDR2,
359-FIB-00125-E	Gasket 10*5*0.5T (RoHS)	2	2
EMI/FUSE PCB			
154-K31505T0-E	Fuse 3.15A 250V 30mm UL/CSA/PSE (RoHS)	1	
155-630R345B-E	Fuse holder UL/CSA φ6*30mm R3-45B (RoHS)	1	
122-14103M4200-E	Inductor RT251510*103N 10mH (RoHS)	1	L02
122-14501M0650-E	Inductor 0.5mH φ0.65 (RoHS)	1	L01
130-3F102MB50-E	Capacitor Y1 1NF 20%250V (RoHS)	2	C03,C04
132-334KB70-E	Capacitor 0.33U 275V +/-10% (RoHS)	1	C02
132-334KB74-E	Capacitor 0.33uF 275V +/-10% LS=15mm (RoHS)	1	C01
162-10099003-E	Wire 90mm20AWG (RoHS)	1	
162-10100007-E	Wire 100mm20AWG (RoHS)	1	
MISCELLANEOUS/MECHANICAL			
195-443391EV-E	Bipolar LED (Cabinet) 339-1EVGW(339-1SURSYGW/S350-A3	1	D401
128-C117JA01-E	electrolytic CAP 110uf 100V	1	Soldered to Woofer terminals
123-11K4DRH-E	Ferrite core K4DRH 16*28.5*9 (RoHS)	3	
123-11RH633215-E	Ferrite coreK5ARH 6.35*3.2*15.8(RoHS)	1	
150-R1107011A-E	Power Transformer TT0930505260120V(RoHS)	1	
152-U602015A-E	Power cord SVTFT-2 6FT#187 BLK (RoHS)	1	
162-10090003-E	WIRE 90mm20AWG (RoHS)	1	
162-5016D001-E	WIRE 24# 160mm (RoHS)	1	
162-5018D007-E	WIRE 180mm 2pin Red/BLK22AWG(RoHS)	1	
166-5070A4BD-E	Speaker wire #18 UL1015#205*0.5t BLK/#250*0.8t Red(R	1	

Part Number	Description	Qty	Reference Designator
MISCELLANEOUS/MECHANICAL			
180-P3024DB-E	Power Switch ROCKER 3024-DB(RoHS)	1	
188-ASDWLAN01-E	RF ANTENNA ASSEMBLYASD-WLAN-01 (RoHS)	1	
193-0S4211-E	(INSULATION SPACER)42*11 (RoHS)	1	
193-201612TR-E	NSULATION SPACER T0-220 16mm*12mm(RoHS)	3	
236-050-05017-0BAE	Fixer ABS 28*Φ12*12H BLK	1	
236-AL-05001-0LAE	RITAINER (RoHS)	1	
302-AL-05167-0BAE	Rear panel 300*200*2.5mm PSW310W120V(RoHS)	1	
306-ABS-05079-0BAE	Rear plastic enclosure 198*298*102H(RoHS)	1	
311-ABS-00028-0BAE	Plastic knob 46077-W P.V.C.(RoHS) Control Knobs	5	
323-AL-05000-0LAE	Heat sink (RoHS)	1	
325-FE-00400-0LAE	PCB stand 58*9*13.5T (RoHS)	1	
333-EVA-00188-0BAE	EVA 170x5x1t (RoHS)	2	
333-EVA-00220-0BAE	EVA 225*15*1t UL(RoHS)	1	
333-EVA-00866-0BAE	Fireproof EVA 48*18*1.5T (RoHS)	1	
333-EVA-05782-0BAE	EVA 90*5*1mm(RoHS)	1	
333-SPG-00860-0BAE	Fireproof damping material 450*50*5T (RoHS)	1	
333-SPG-00863-0BAE	Fireproof damping material 100*50*5T (RoHS)	5	
335-NYL-05015-0BAE	WIRE CLKP SB4F-2 BLK(RoHS)	2	
336-RUB-05103-0BAE	RUB 97*16*3.0T BLK(RoHS)	2	
350-EM04012D024-E	4 ϕ *12 WOOD SCREW BLACK(RoHS)	4	
351-AM02606A011-E	M2.6*6 Mechanical screw cross BLK(RoHS)	2	
351-AM03008A078-E	M3*8 Mechanical screw with nickel(RoHS)	10	
351-AM03008A079-E	M3*8 Mechanical screw cross BLK(RoHS)	9	
351-AM03018A364-E	Mechanical screw cross M3*18 BLK (RoHS)	2	
351-HM03006A308-E	Mechanical screw cross M3*6mm BLK (RoHS)	1	
351-HM04010A217-E	M4*10 Mechanical screw cross BLK	4	
352-AM02606C1136-E	Screw T26*6 BLK	2	
352-AM03008D040-E	ϕ 3*8 B type ping screw cross BLK (RoHS)	2	
352-AM03008D041-E	ϕ 3*8 B type ping screw cross with nickel (RoHS)	2	
352-AM03010D065-E	ϕ 3*10 P type ping screw cross BLK(RoHS)	1	
354-HM03005-E	M3 nut BLK (RoHS)	1	
355-P07049-E	Washer 7.2*12*0.5t (RoHS)	2	
361-FE-00002-0LAE	Bracket for Transformer 90*70*15mm (RoHS)	1	
362-FE-00013-0LAE	PCB stand L TYPE t=1.6mmS.P.C.C 89*9*1.6T (RoHS)	3	
362-NYL-05049-0LAE	PCB post M3 10H (RoHS)	2	



October 2004

LM5008

High Voltage (100V) Step Down Switching Regulator

General Description

The LM5008 Step Down Switching Regulator features all of the functions needed to implement a low cost, efficient, Buck bias regulator. This high voltage regulator contains an 100 V N-Channel Buck Switch. The device is easy to implement and is provided in the MSOP-8 and the thermally enhanced LLP-8 packages. The regulator is based on a hysteretic control scheme using an ON time inversely proportional to V_{IN} . This feature allows the operating frequency to remain relatively constant. The hysteretic control requires no loop compensation. An intelligent current limit is implemented with forced OFF time, which is inversely proportional to V_{out} . This scheme ensures short circuit protection while providing minimum foldback. Other protection features include: Thermal Shutdown, V_{CC} under-voltage lockout, Gate drive under-voltage lockout, and Max Duty Cycle limiter

Features

- Integrated 100V, N-Channel buck switch
- Internal V_{CC} regulator
- No loop compensation required
- Ultra-Fast transient response
- On time varies inversely with line voltage
- Operating frequency remains constant with varying line voltage and load current
- Adjustable output voltage
- Highly efficient operation
- Precision internal reference
- Low bias current
- Intelligent current limit protection
- Thermal shutdown

Typical Applications

- Non-Isolated Telecommunication Buck Regulator
- Secondary High Voltage Post Regulator
- +42V Automotive Systems

Package

- MSOP - 8
- LLP - 8 (4mm x 4mm)

Connection Diagram

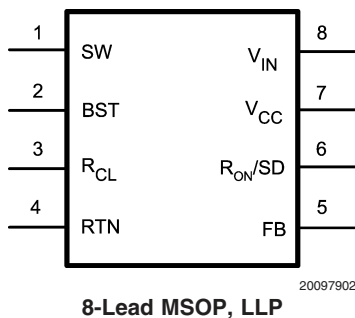

Ordering Information

Order Number	Package Type	NSC Package Drawing	Supplied As
LM5008MM	MSOP-8	MUA08A	1000 Units on Tape and Reel
LM5008SD	LLP-8	SDC08A	1000 Units on Tape and Reel

LM5008 High Voltage (100V) Step Down Switching Regulator

Pin Description

PIN	NAME	DESCRIPTION	APPLICATION INFORMATION
1	SW	Switching Node	Power switching node. Connect to the output inductor, re-circulating diode, and bootstrap capacitor.
2	BST	Boost Pin (Boot-strap capacitor input)	An external capacitor is required between the BST and the SW pins. A 0.01µF ceramic capacitor is recommended. An internal diode charges the capacitor from V _{CC} .
3	R _{CL}	Current Limit OFF time set pin $T_{off} = 10^{-5} / (0.285 + (FB / 6.35 \times 10^{-6} \times R_{CL}))$	A resistor between this pin and RTN sets the off-time when current limit is detected. The off-time is preset to 35µs if FB = 0V.
4	RTN	Ground pin	Ground for the entire circuit.
5	FB	Feedback input from Regulated Output	This pin is connected to the inverting input of the internal regulation comparator. The regulation threshold is 2.5V.
6	R _{ON} /SD	On time set pin $T_{on} = 1.25 \times 10^{-10} R_{ON} / V_{IN}$	A resistor between this pin and V _{IN} sets the switch on time as a function of V _{IN} . The minimum recommended on time is 400ns at the maximum input voltage. This pin can be used for remote shutdown.
7	V _{CC}	Output from the internal high voltage series pass regulator. Regulated at 7.0V.	If an auxiliary voltage is available to raise the voltage on this pin, above the regulation setpoint (7V), the internal series pass regulator will shutdown, reducing the IC power dissipation. Do not exceed 14V. This voltage provides gate drive power for the internal Buck switch. An internal diode is provided between this pin and the BST pin. A local 0.1µF decoupling capacitor is recommended. Series pass regulator is current limited to 10mA.
8	V _{IN}	Input voltage	Recommended operating range: 9.5V to 95V.

LM5008

Typical Application Circuit and Block Diagram

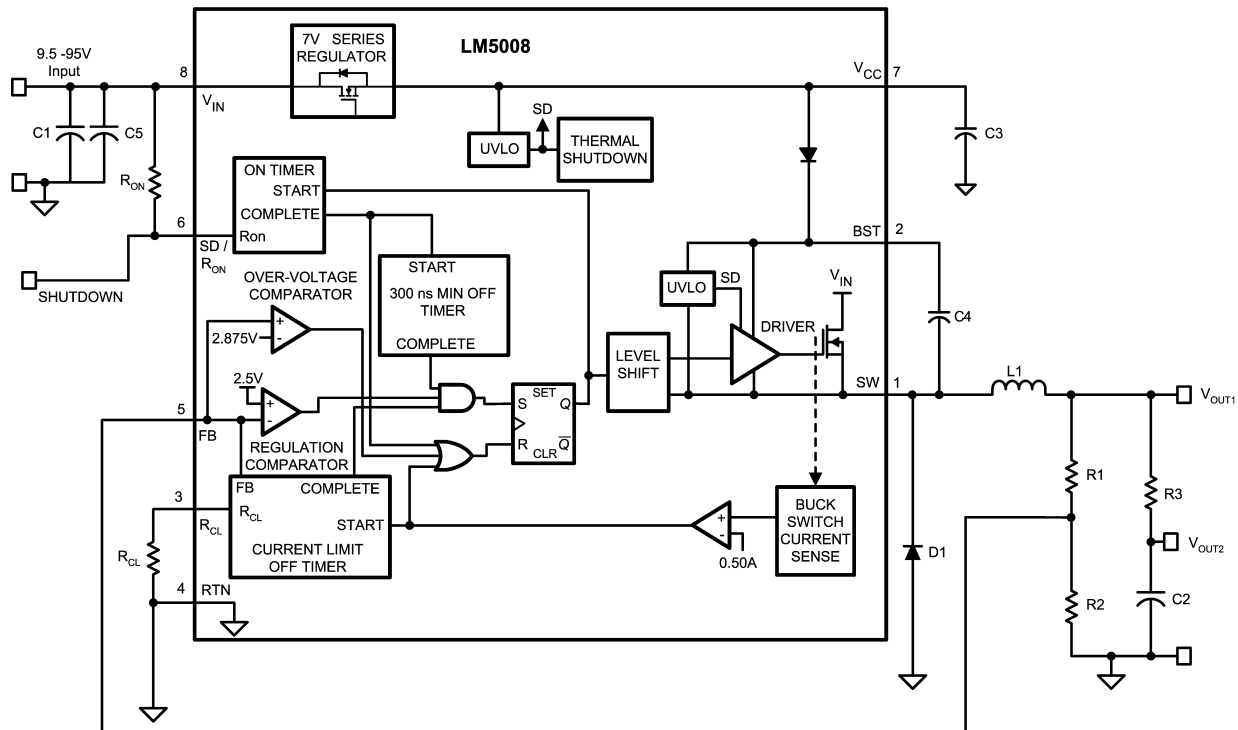

20097901

8-bit parallel-in/serial-out shift register

74HC/HCT165

FEATURES

- Asynchronous 8-bit parallel load
- Synchronous serial input
- Output capability: standard
- I_{CC} category: MSI

GENERAL DESCRIPTION

The 74HC/HCT165 are high-speed Si-gate CMOS devices and are pin compatible with low power Schottky TTL (LSTTL). They are specified in compliance with JEDEC standard no. 7A.

The 74HC/HCT165 are 8-bit parallel-load or serial-in shift registers with complementary serial outputs (Q_7 and $\overline{Q_7}$) available from the last stage. When the parallel load (\overline{PL}) input is LOW, parallel data from the D_0 to D_7 inputs are loaded into the register asynchronously.

When \overline{PL} is HIGH, data enters the register serially at the D_s input and shifts one place to the right ($Q_0 \rightarrow Q_1 \rightarrow Q_2$, etc.) with each positive-going clock transition. This feature allows parallel-to-serial converter expansion by tying the Q_7 output to the D_s input of the succeeding stage.

The clock input is a gated-OR structure which allows one input to be used as an active LOW clock enable (\overline{CE}) input. The pin assignment for the CP and \overline{CE} inputs is arbitrary and can be reversed for layout convenience. The LOW-to-HIGH transition of input \overline{CE} should only take place while CP HIGH for predictable operation. Either the CP or the \overline{CE} should be HIGH before the LOW-to-HIGH transition of \overline{PL} to prevent shifting the data when \overline{PL} is activated.

APPLICATIONS

- Parallel-to-serial data conversion

QUICK REFERENCE DATA

GND = 0 V; T_{amb} = 25 °C; t_r = t_f = 6 ns

SYMBOL	PARAMETER	CONDITIONS	TYPICAL		UNIT
			HC	HCT	
t _{PHL} / t _{PLH}	propagation delay	C _L = 15 pF; V _{CC} = 5 V			
	CP to $Q_7, \overline{Q_7}$		16	14	ns
	\overline{PL} to $Q_7, \overline{Q_7}$		15	17	ns
	D ₇ to $Q_7, \overline{Q_7}$		11	11	ns
f _{max}	maximum clock frequency		56	48	MHz
C _I	input capacitance		3.5	3.5	pF
C _{PD}	power dissipation capacitance per package	notes 1 and 2	35	35	pF

Notes

1. C_{PD} is used to determine the dynamic power dissipation (P_D in μ W):

$$P_D = C_{PD} \times V_{CC}^2 \times f_i + \sum (C_L \times V_{CC}^2 \times f_o) \text{ where:}$$

f_i = input frequency in MHz

f_o = output frequency in MHz

$\sum (C_L \times V_{CC}^2 \times f_o)$ = sum of outputs

C_L = output load capacitance in pF

V_{CC} = supply voltage in V

2. For HC the condition is V_I = GND to V_{CC}
For HCT the condition is V_I = GND to V_{CC} – 1.5 V

ORDERING INFORMATION

See "74HC/HCT/HCU/HCMOS Logic Package Information".

8-bit parallel-in/serial-out shift register

74HC/HCT165

PIN DESCRIPTION

PIN NO.	SYMBOL	NAME AND FUNCTION
1	\overline{PL}	asynchronous parallel load input (active LOW)
7	$\overline{Q_7}$	complementary output from the last stage
9	Q_7	serial output from the last stage
2	CP	clock input (LOW-to-HIGH edge-triggered)
8	GND	ground (0 V)
10	D_s	serial data input
11, 12, 13, 14, 3, 4, 5, 6	D_0 to D_7	parallel data inputs
15	\overline{CE}	clock enable input (active LOW)
16	V_{CC}	positive supply voltage

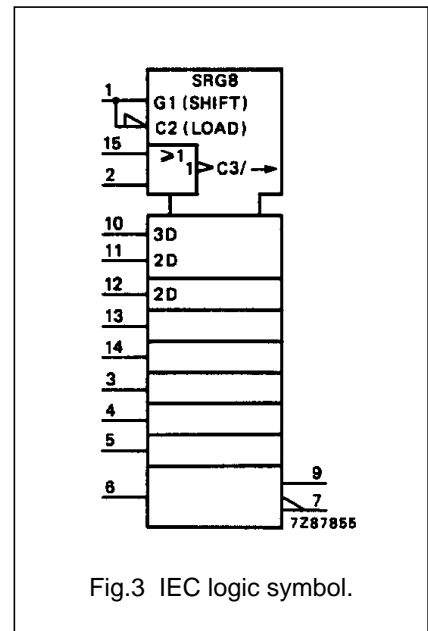
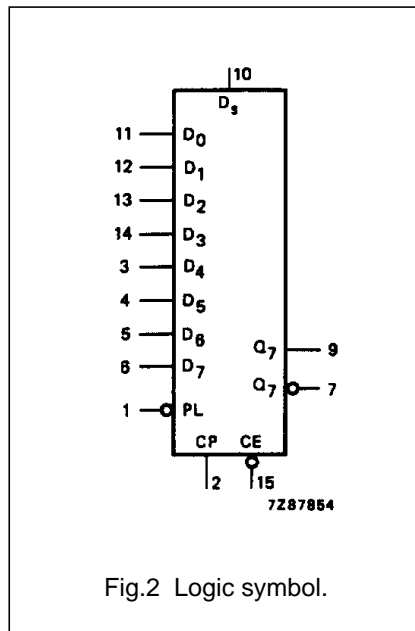
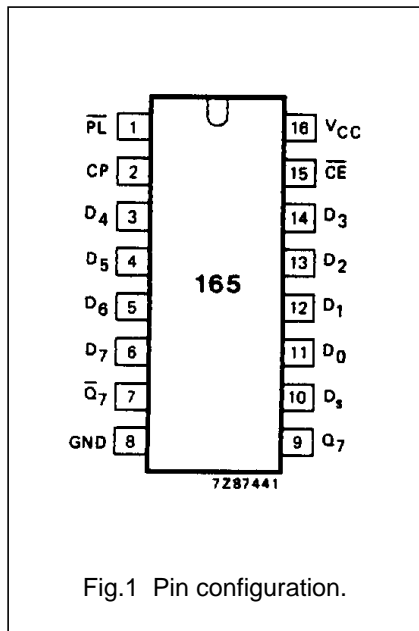

8-bit parallel-in/serial-out shift register

74HC/HCT165

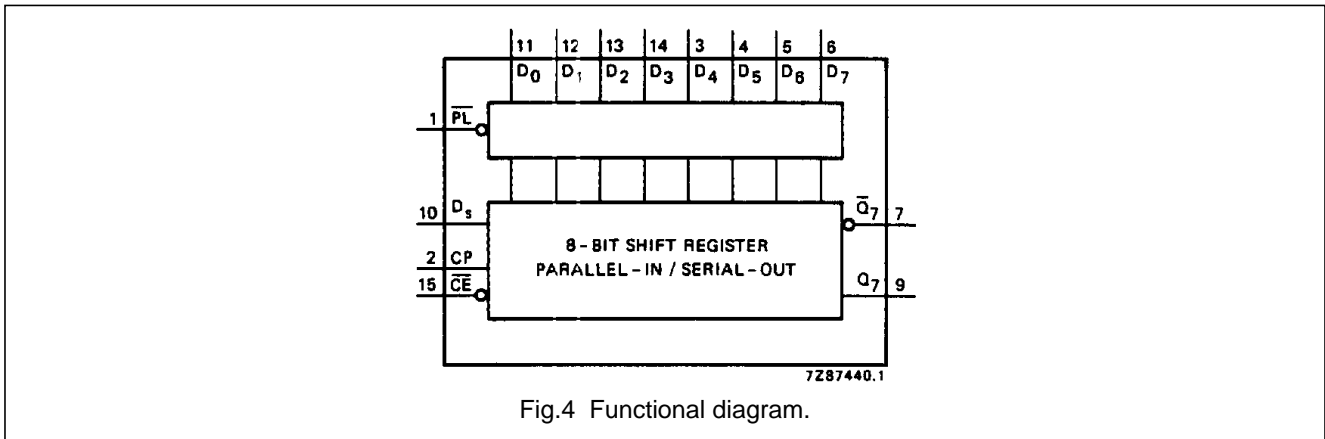

Fig.4 Functional diagram.

FUNCTION TABLE

OPERATING MODES	INPUTS					Q _n REGISTERS		OUTPUTS	
	\overline{PL}	\overline{CE}	CP	D _s	D ₀ -D ₇	Q ₀	Q ₁ -Q ₆	Q ₇	$\overline{Q_7}$
parallel load	L	X	X	X	L	L	L - L	L	H
	L	X	X	X	H	H	H - H	H	L
serial shift	H	L	↑	l	X	L	q ₀ -q ₅	q ₆	$\overline{q_6}$
	H	L	↑	h	X	H	q ₀ -q ₅	q ₆	q ₆
hold "do nothing"	H	H	X	X	X	Q ₀	Q ₁ -Q ₆	Q ₇	Q ₇

Note

- H = HIGH voltage level
 h = HIGH voltage level one set-up time prior to the LOW-to-HIGH clock transition
 L = LOW voltage level
 l = LOW voltage level one set-up time prior to the LOW-to-HIGH clock transition
 q = lower case letters indicate the state of the referenced output one set-up time prior to the LOW-to-HIGH clock transition
 X = don't care
 ↑ = LOW-to-HIGH clock transition

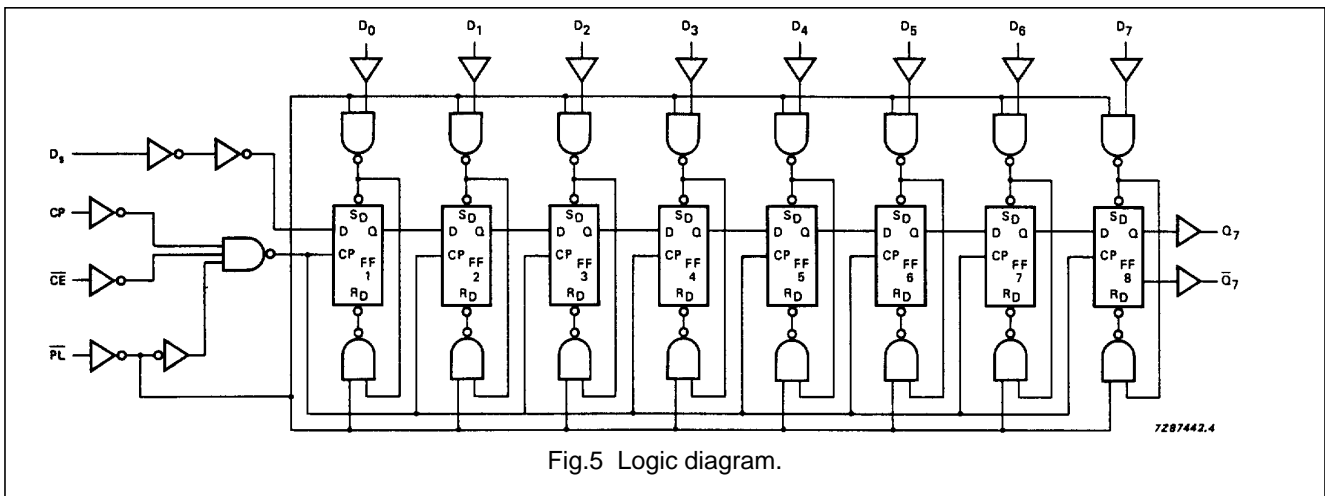

Fig.5 Logic diagram.



CS4340

24-Bit, 96 kHz Stereo DAC for Audio

Features

- Complete Stereo DAC System: Interpolation, D/A, Output Analog Filtering
- 101 dB Dynamic Range
- 91 dB THD+N
- Low Clock Jitter Sensitivity
- +3 V to +5 V Power Supply
- Filtered Line Level Outputs
- On-Chip Digital De-emphasis for 32, 44.1, and 48 kHz
- 30 mW with 3 V supply
- Popguard[®] Technology for Control of Clicks and Pops

Description

The CS4340 is a complete stereo digital-to-analog system including digital interpolation, fourth-order delta-sigma digital-to-analog conversion, digital de-emphasis and switched capacitor analog filtering. The advantages of this architecture include: ideal differential linearity, no distortion mechanisms due to resistor matching errors, no linearity drift over time and temperature and a high tolerance to clock jitter.

The CS4340 accepts data at audio sample rates from 2 kHz to 100 kHz, consumes very little power, and operates over a wide power supply range. The features of the CS4340 are ideal for DVD players, CD players, set-top box and automotive systems.

ORDERING INFORMATION

CS4340-KS	16-pin SOIC, -10 to 70 °C
CS4340-BS	16-pin SOIC, -40 to 85 °C
CDB4340	Evaluation Board

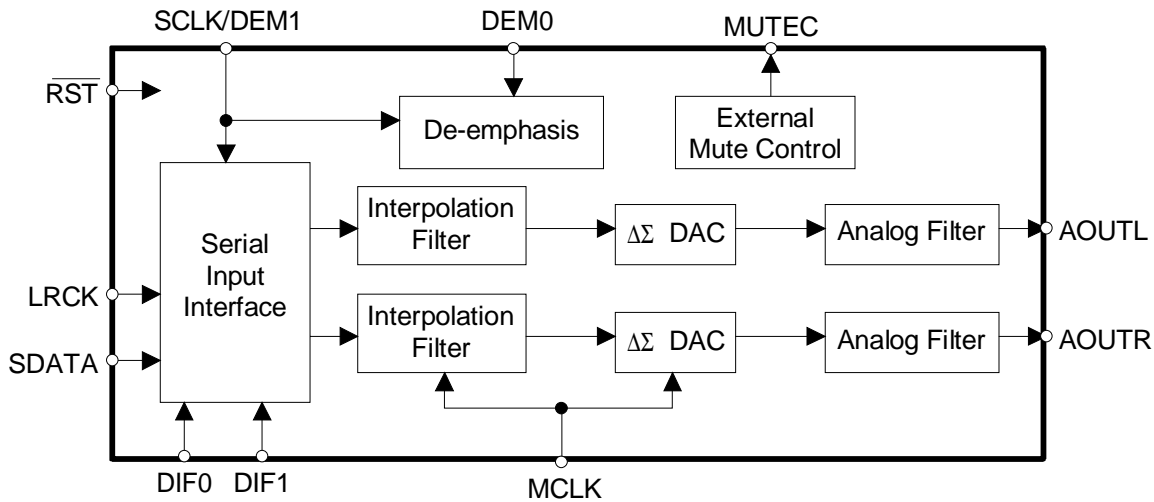

Preliminary Product Information

This document contains information for a new product. Cirrus Logic reserves the right to modify this product without notice.



CS4340

3. PIN DESCRIPTION

Reset	$\overline{\text{RST}}$	1	16	MUTEC	Mute Control
Serial Data	SDATA	2	15	AOUTL	Left Analog Output
Serial Clock / De-emphasis	SCLK/DEM1	3	14	VA	Analog Power
Left/Right Clock	LRCK	4	13	AGND	Analog Ground
Master Clock	MCLK	5	12	AOUTR	Right Analog Output
Digital Interface Format	DIF1	6	11	REF_GND	Reference Ground
Digital Interface Format	DIF0	7	10	VQ	Quiescent Voltage
De-emphasis	DEM0	8	9	FILT+	Positive Voltage Reference

$\overline{\text{RST}}$	1	Reset (Input) - The device enters a low power mode and all internal state machines are reset to the default settings when low. $\overline{\text{RST}}$ should be held low during power-up until the power supply, master and left/right clocks are stable.
SDATA	2	Serial Audio Data (Input) - Two's complement MSB-first serial data is input on this pin. The data is clocked into SDATA via the serial clock and the channel is determined by the Left/Right clock. The required relationship between the Left/Right clock, serial clock and serial data is defined by the DIF1-0 pins. The options are detailed in Figures 16-19.
SCLK	3	Serial Clock (Input) - Clocks the individual bits of the serial data into the SDATA pin. The required relationship between the Left/Right clock, serial clock and serial data is defined by the DIF1-0 pins. The options are detailed in Figures 16-19. The CS4340 supports both internal and external serial clock generation modes. Internal SCLK mode is used to gain access to extra de-emphasis modes. <u>Internal Serial Clock Mode</u> - In the Internal Serial Clock Mode, the serial clock is internally derived and synchronous with the master clock and left/right clock. The SCLK/LRCK frequency ratio is either 32, 48, or 64 depending upon the DIF1-0 pins as shown in Figures 16-19. Operation in this mode is identical to operation with an external serial clock synchronized with LRCK. <u>External Serial Clock Mode</u> - The CS4340 will enter the External Serial Clock Mode whenever 16 low to high transitions are detected on the SCLK pin during any phase of the LRCK period. The device will revert to Internal Serial Clock Mode if no low to high transitions are detected on the SCLK pin for 2 consecutive periods of LRCK.



STM809, STM810 STM811, STM812

Reset Circuit

FEATURES SUMMARY

- PRECISION MONITORING OF 3V, 3.3V, and 5V SUPPLY VOLTAGES
- TWO OUTPUT CONFIGURATIONS
 - Push-pull $\overline{\text{RST}}$ Output (STM809/811)
 - Push-pull RST Output (STM810/812)
- 140ms RESET PULSE WIDTH (MIN)
- LOW SUPPLY CURRENT - 6 μ A (TYP)
- GUARANTEED $\overline{\text{RST}}$ /RST ASSERTION DOWN TO $V_{\text{CC}} = 1.0\text{V}$
- OPERATING TEMPERATURE:
 - 40°C to 85°C (Industrial Grade)
- LEAD-FREE, SMALL SOT23 and SOT143 PACKAGE

Table 1. Device Options

	Active-Low RESET	Active-High RESET	Manual RESET Input	Package
STM809	✓			SOT23-3
STM810		✓		SOT23-3
STM811	✓		✓	SOT143-4
STM812		✓	✓	SOT143-4

Figure 1. Packages

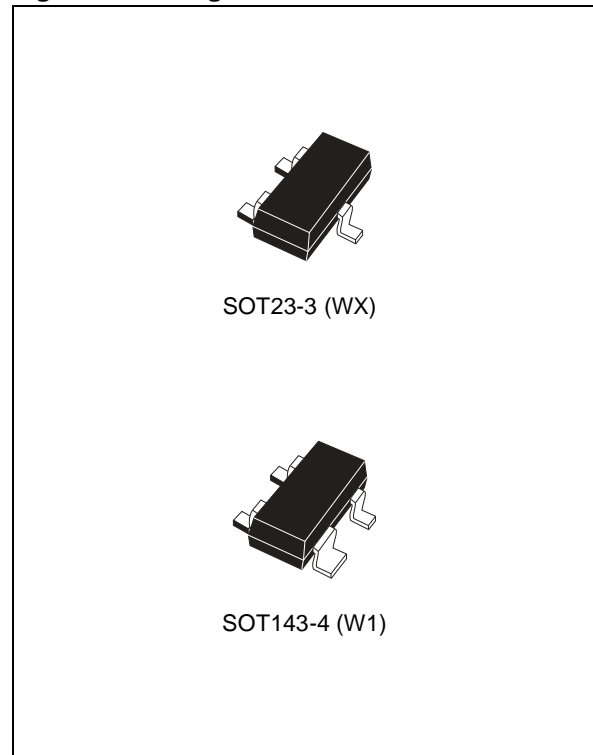

STM809/810/811/812

SUMMARY DESCRIPTION

The STM809/810/811/812 MICROPROCESSOR RESET Circuits are low-power supervisory devices used to monitor power supplies. They perform a single function: asserting a reset signal whenever the V_{CC} supply voltage drops below a preset

value and keeping it asserted until V_{CC} has risen above the preset threshold for a minimum period of time (t_{rec}). The STM811/812 also provide a push-button reset input (MR).

Figure 2. Logic Diagram (STM809/810)

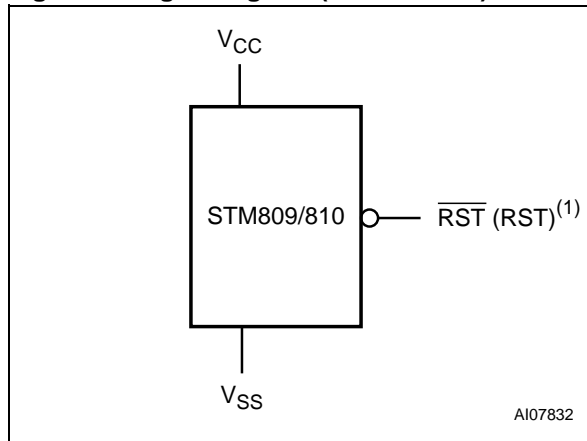

Note: 1. For STM810

Figure 3. Logic Diagram (STM811/812)

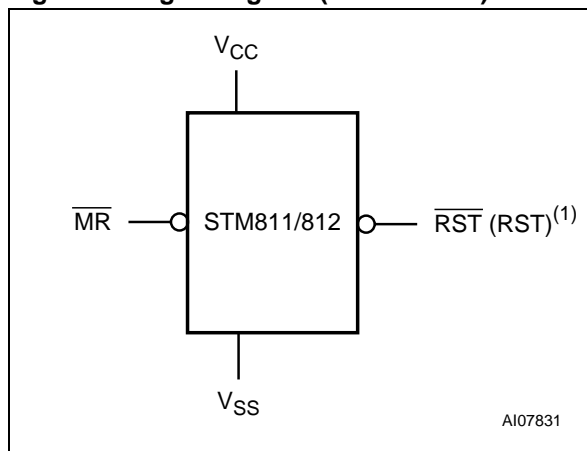

Note: 1. For STM812

Table 2. Signal Names

V_{SS}	Ground
\overline{RST}	Active-Low RESET Output
RST ⁽¹⁾	Active-High RESET Output
V_{CC}	Supply Voltage
\overline{MR} ⁽²⁾	Manual Reset Input

Note: 1. STM810/812 only
2. STM811/812 only

Figure 4. SOT23-3 Connections

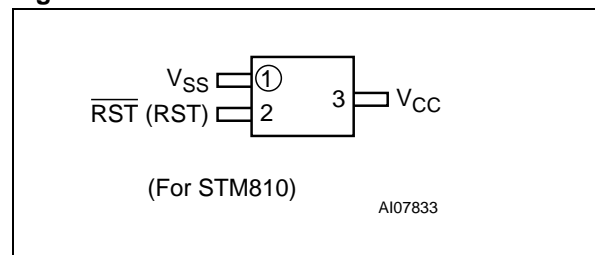

Figure 5. SOT143-4 Connections

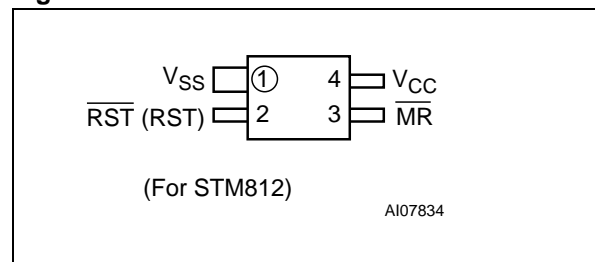
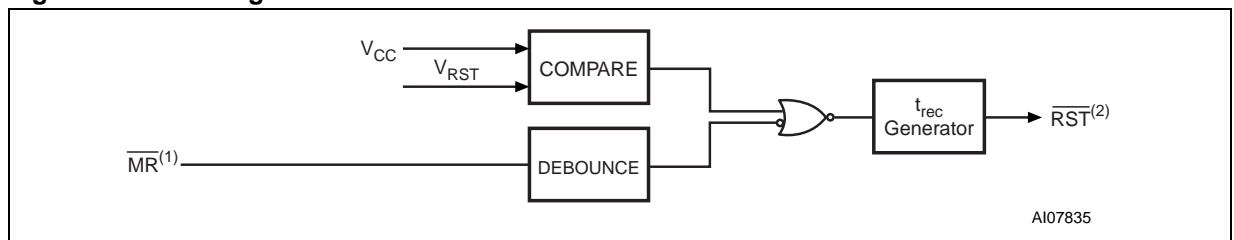
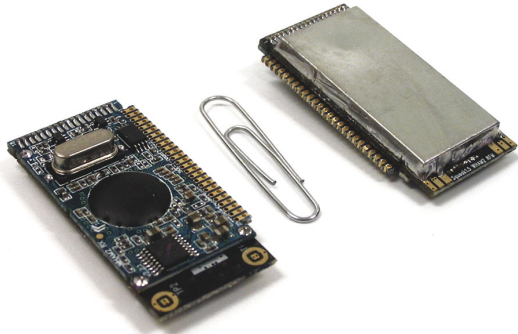

Figure 6. Block Diagram



Note: 1. STM811/812 only
2. RST for STM810/812

High-Performance 2.4 GHz Digital Wireless Audio Solution



GENERAL DESCRIPTION

The Squeak 1.5 WHAM2 (Wireless HiFi Audio Module) is a highly integrated module package that provides a complete solution for wireless audio. Squeak 1.5, using the Micro Linear ML2724 radio transceiver front end and the XInC2 wireless processor, is ideal for high performance wireless audio applications such as home theater, stereo and outdoor speakers, and microphones. Squeak 1.5 is available in either a 25 or 50 meter indoor range WHAM2 module.

The WHAM2 digitizes a 2-channel stereo input signal, sends it across a robust 2.4 GHz radio frequency link, and converts the signal back to a stereo analog signal for use at a remote location. WHAM2 is also available with a Digital Audio Serial Interface (DASI) port that can be configured to interface with any SPI supporting device (I²S, left- or right-justified), including ADCs, DACs, digital audio streams such as S/P-DIF or USB. A development kit is required to modify the DASI port and/or to modify application source code firmware.

FEATURES

- Analog or Digital Audio Input/Output
- 48 kHz, 16-bit digital, stereo audio transmission
- Digital volume control, manual mute
- Auto mute (when signal lost), digital noise gate
- 2.4 GHz wireless at 1.536 Mbps
- Robust Quality of Service (QoS)
- Advanced error protection protocols with hardware forward error correction, adaptive frequency hopping, and walking frequency diversity
- 25 or 50 meter indoor range
- Up to 6 transmitters in specified range area
- Low latency; firmware selectable 15 – 64 ms
- Duplex utility control channel at 1.5 kbps
- Programmable for custom features (with development kit)

ORDERING INFORMATION

		25 meter	50 meter
Analog I/O	TX	WH4924	WH4928
	RX	WH4925	WH4929
Digital I/O	TX	WH4926	WH4930
	RX	WH4927	WH4931
Evaluation Kit	2-node	EV4931	EV4937
	Add-on node	EV4933	EV4939
Dev. Kit	Upgrade from any eval. kit	DK4909	

BLOCK DIAGRAM

Squeak 1.5 WHAM2 TX

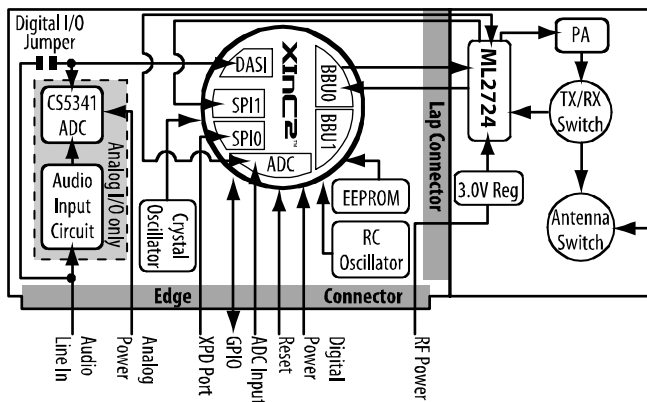

Squeak 1.5 WHAM2 RX

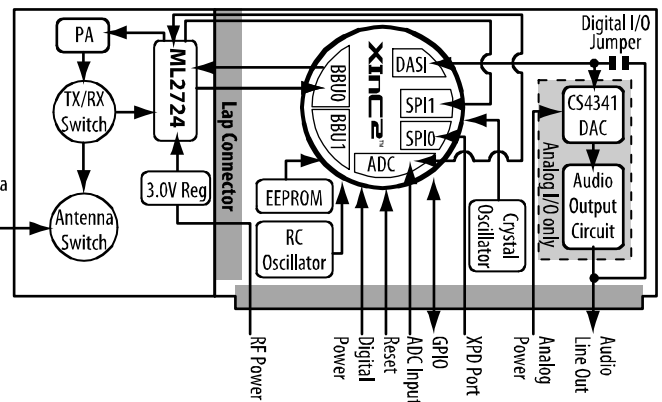

WHAM2 Receiver Pinout

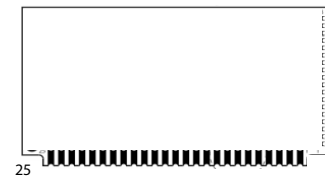

Pin#	Pin Name	Analog I/O Default	Digital I/O Default	Description
1	RFVCC	RFVCC	RFVCC	RF Voltage Power Input
2	RFGND	RFGND	RFGND	RF Ground
3	GND	GND	GND	Digital Ground
4	VCC	VCC	VCC	Digital Power Input
5	/RESET	/RESET	/RESET	Reset input (active low)
6	PB1	PB1	PB1	SPI0 Chip Select (CS0) PB1
7	MISO0/ PG0	MISO0	MISO0	SPI0 Master Data Input MISO0 (FW default), or GPIO port PG0
8	MOSI0/ PG1	MOSI0	MOSI0	SPI0 Master Data Output MOSI0 (FW default), or GPIO port PG1
9	SCK0/ PG2	SCK0	SCK0	SPI0 Clock output SCK0 (FW default), or GPIO port PG2
10	PF0/ SDIO1	PF0	PF0	General Purpose IO port PF0 (FW default), or Digital Audio Serial Interface1 (DASI)
11	PF1/ SDIO2	PF1	PF1	General Purpose IO port PF1 (FW default), or Digital Audio Serial Interface2 (DASI)
12	PC7	PC7	PC7	General Purpose IO port PC7
13	PC6	PC6	PC6	General Purpose IO port PC6
14	PC5	PC5	PC5	General Purpose IO port PC5
15	PC4	PC4	PC4	General Purpose IO port PC4
16	PC0/ MCLK	PC0	MCLK	General Purpose IO port PC0, or MCLK output
17	PC1/ AN2	PC1	PC1	General Purpose IO port PC1 (HW default), or XInC2 ADC Analog Input #2
18	PI0/ BB1CLK/ AN1	PI0	PI0	General Purpose IO port PI0 (HW & FW default), or Baseband Unit1 Clock, or XInC2 ADC Analog Input #1
19	PI1/ BB1O/ LRCK	PI1	LRCK	General Purpose IO PI1, or Baseband Unit1 Output, or Left-Right Clock (LRCK)
20	PI2/ BB1I	PI2	PI2	General Purpose IO PI2 (HW & FW default), or Baseband Unit1 Input
21	AGND	AGND	GND	Analog Ground
22	AOUTR/ SDIO0	AOUTR	SDIO0	Audio line-out for Right Channel AOUTR, or Serial DASI Data input/output SDIO0
23	AOUTL/ BCLK	AOUTL	BCLK	Audio line-out for Left Channel AOUTL, or Serial DASI Bit Clock output BCLK
24	AGND	AGND	GND	Analog Ground
25	AVDD	AVDD	(no connect)	Analog Power Input

Table 6 – WHAM2 RX Pinouts

1.4 ADVANCED PINOUT CONFIGURATION

The WHAM2 pinout can be configured differently than above for certain applications. This customization can be performed at the time of production or during product assembly.

The following two diagrams and two tables describe how to configure the WHAM2 for different operations by changing jumpers and components on the modules themselves.

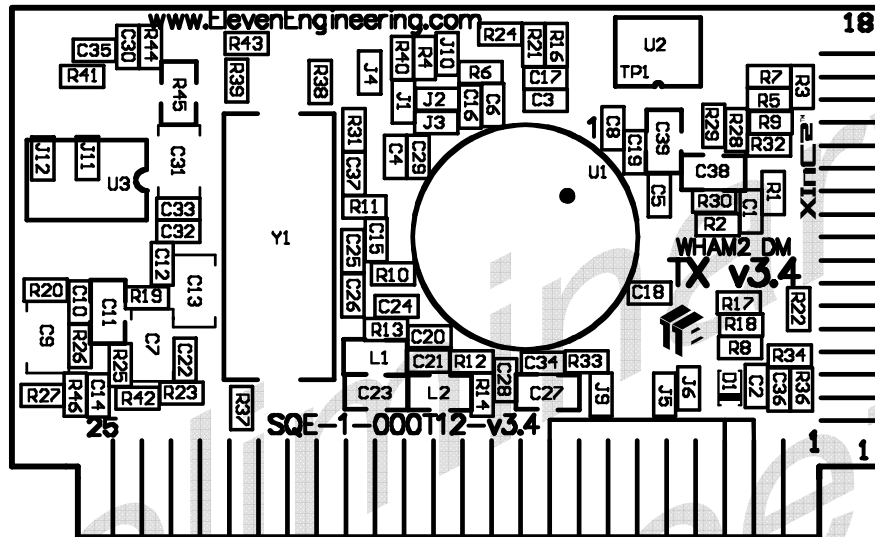

Figure 1 - WHAM2 Transmitter DM Layout

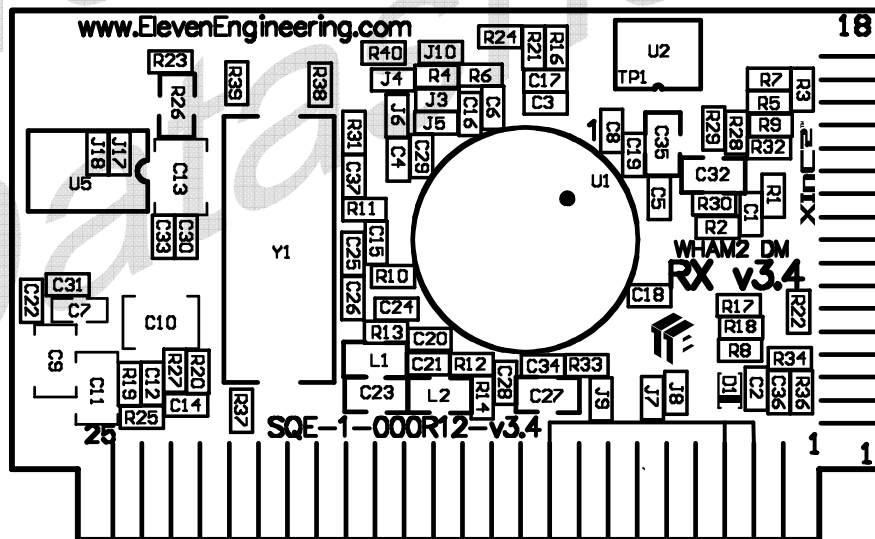

Figure 2 - WHAM2 Receiver DM Layout

WHAM2 RX Jumpers and Options

Pin Name	Jumpers/ Components	Pin Function	WH4925/29 Default config.	WH4927/31 Default config.
Edge pin-16	J3 = 0R J4 = DNP	Pin 16 is GPIO port pin PC0 (FW configurable as input or output.)	★	
	J3 = DNP J4 = 0R	Pin 16 is MCLK (output) (FW programmable frequency: typically 12.288, 24.576, or 49.152 MHz.)		★
Edge pin-17	J5 = 0R J6 = DNP	Pin 17 is GPIO port pin PC1 (FW configurable as input or output)	★	★
	J5 = DNP J6 = 0R	Pin 17 is AN2 (XInC2 muxed analog input #2.) (Input voltage range of ADC is 0V to 1.8V.)		
Edge pin-18	J7 = 0R J8 = DNP	Pin 18 is FW selectable as either GPIO port pin PI0 or baseband unit #1 clock pin BB1CLK. (PI0 is FW configurable as input or output.)	★	★
	J7 = DNP J8 = 0R	Pin 18 is AN1 (XInC2 muxed analog input #1.) (Input voltage range of ADC is 0V to 1.8V.)		
Edge pin-19	J9 = 0R J10 = DNP	Pin 19 is FW selectable as either GPIO port pin PI1 or baseband unit #1 data input/output pin BB1O. (PI1 is FW configurable as input or output.)	★	
	J9 = DNP J10 = 0R	Pin 19 is Left-Right Clock pin LRCK (output)		★
Edge pins 22 & 23	J17, J18 = DNP U5 = CS4341, R19, R20 = 10K, R23 = 47K, R25, R27 = 100R, R26 = 0R, C7 = 1uF, C9, C13 = 10uF, C12, C14 = 8200pF, C22, C30, C31 = 0.1uF, C33 = 470pF.	Pin 22 is Right channel Analog Audio Output: AOUTR Pin 23 is Left channel Analog Audio Output: AOUL	★	
	J17, J18 = 0R U5 = DNP, R19, R20, R23 = DNP, R25-R27 = DNP, C7 = DNP, C9, C13 = DNP, C12, C14 = DNP, C22, C30, C31 = DNP, C33 = DNP	Pin 22 is serial digital data I/O port pin SDIO0 Pin 23 is Serial digital audio clock SCLK		★

Table 8 – WHAM2 RX Jumper Configurations

Integrated Circuit Diagrams

TL072 DUAL OP-AMP
IC1, U101,103,105,108,109

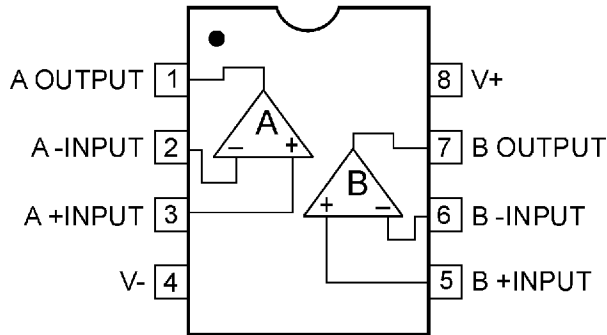

QUAD OPAMP,
14P DIL TL074 LM324
U102,104,106,107

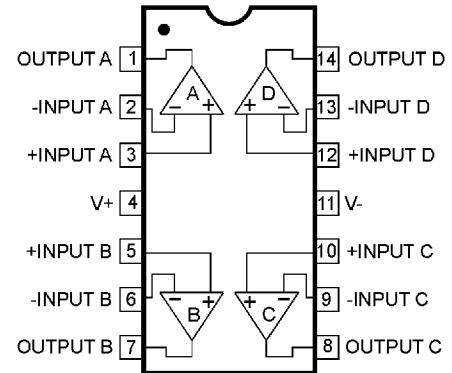

- MMBT3906
- MMBT1015
- MMBT1815
- 2SC4672K(MPT3)
- 2Sa1037K-T146Q/r
- 2SC2412K
- 2SA1514K

2N5401
Q6B, 108

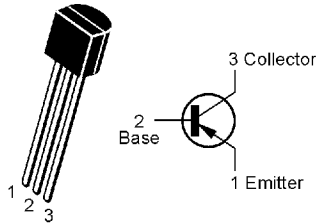

MOSFET IRF640, 9640
Q10,10B,11

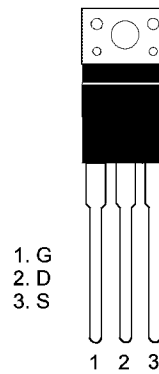

FET J111
Q107

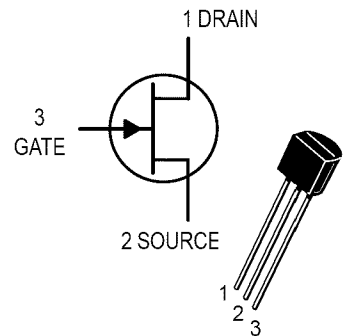

Q1,2,3,4,5B,7,8,9
Q101-103, Q400-403

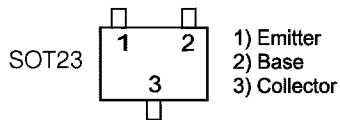

* PREFIX MAY BE "FMMT"

TL431 D115

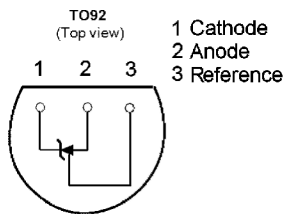

2N5551
Q109

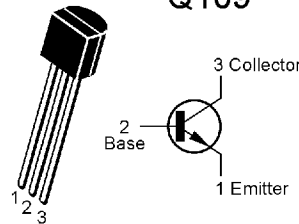

2SA1015
Q111,113,115

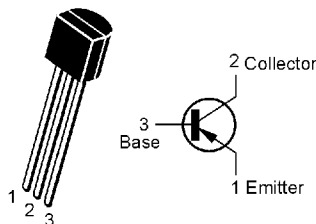

HSD669A, HSB649A
Q116,118

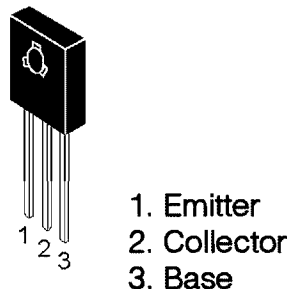

2SC1815
Q110,112,114,117

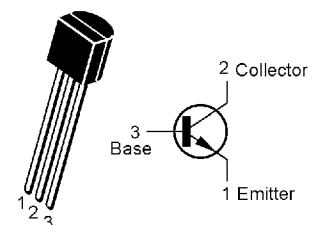

PSW310W subwoofer Classia Series

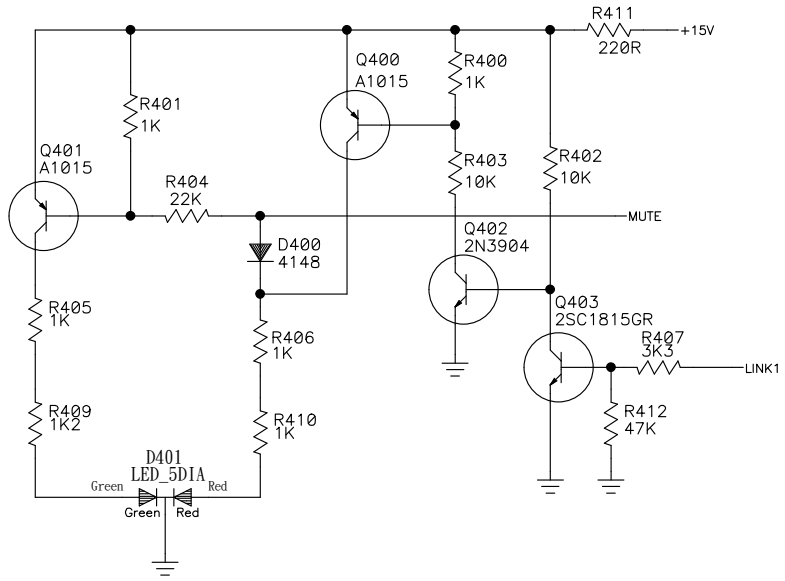

Draw.

Dsgn.

Apvd.

Filename	LDE	Rev	A0	Size	A4
Model No.	PSW310W 120V	1	PAGE:7/12		
Drawn by	HUAJIAN 46	2	CUSTOMER:Infinity		
Date	2008-04-24	3			

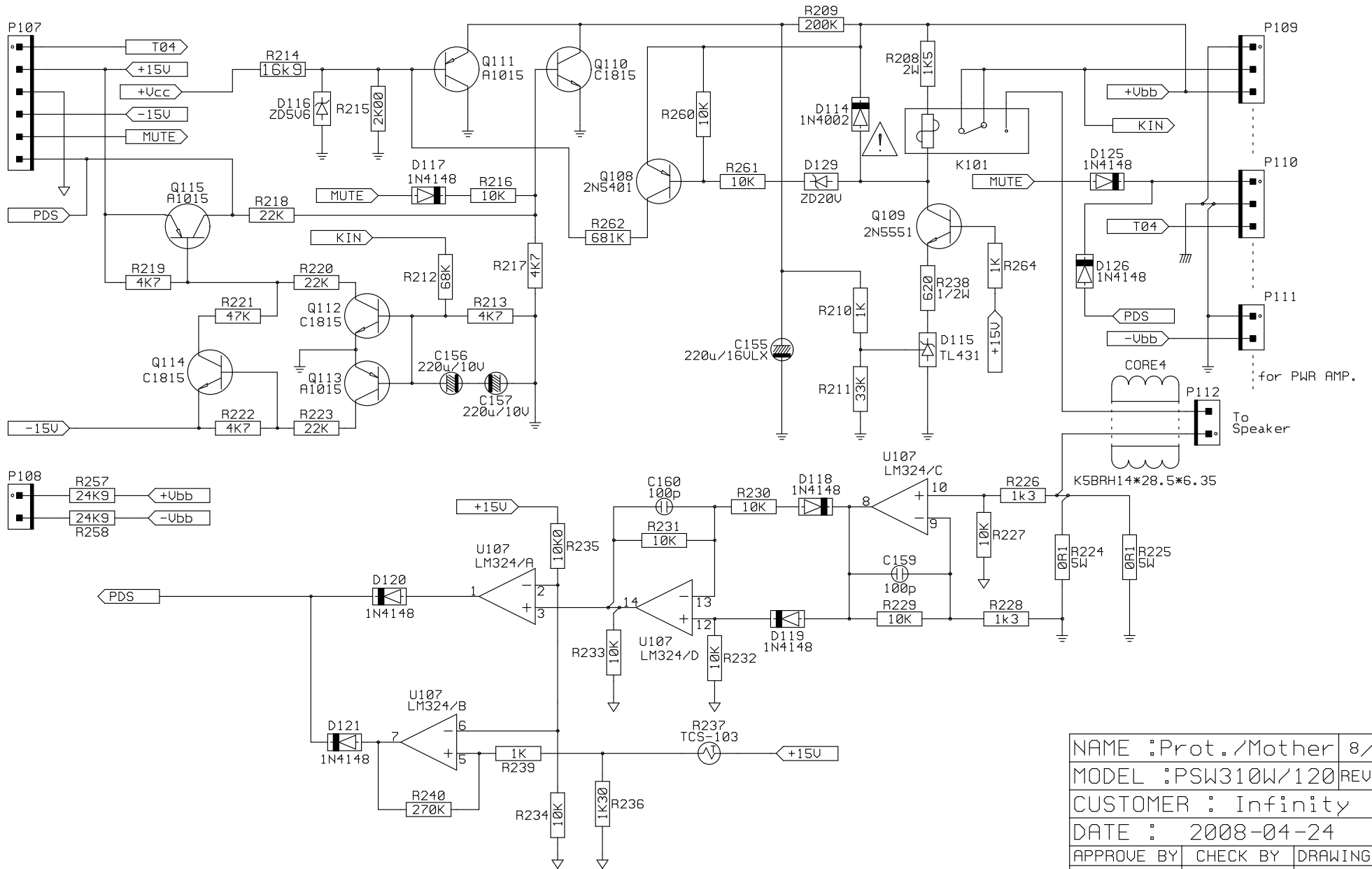

NAME : Prot./Mother	8/12
MODEL : PSW310W/120	REV:A0
CUSTOMER : Infinity	
DATE : 2008-04-24	
APPROVE BY	CHECK BY
DRAWING BY	

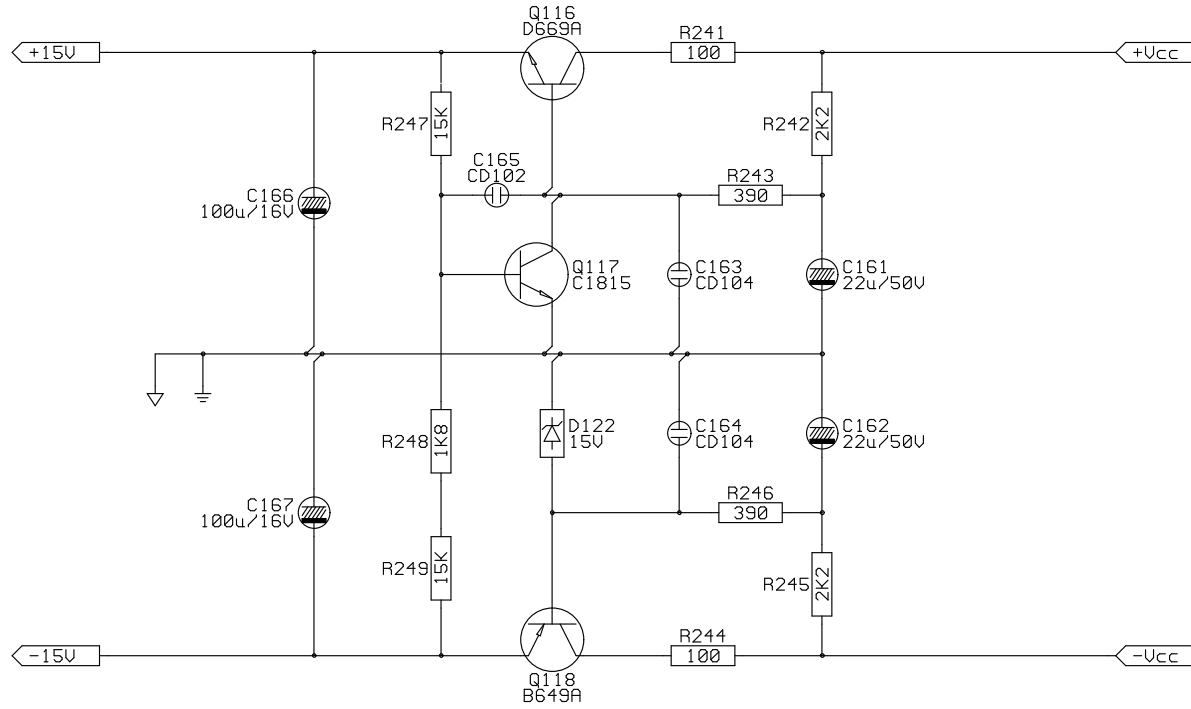

NAME : PN15U/Mother	9/12
MODEL : PSW310W/120	REV:A0
CUSTOMER : Infinity	
DATE : 2008-04-24	
APPROVE BY	CHECK BY DRAWING BY

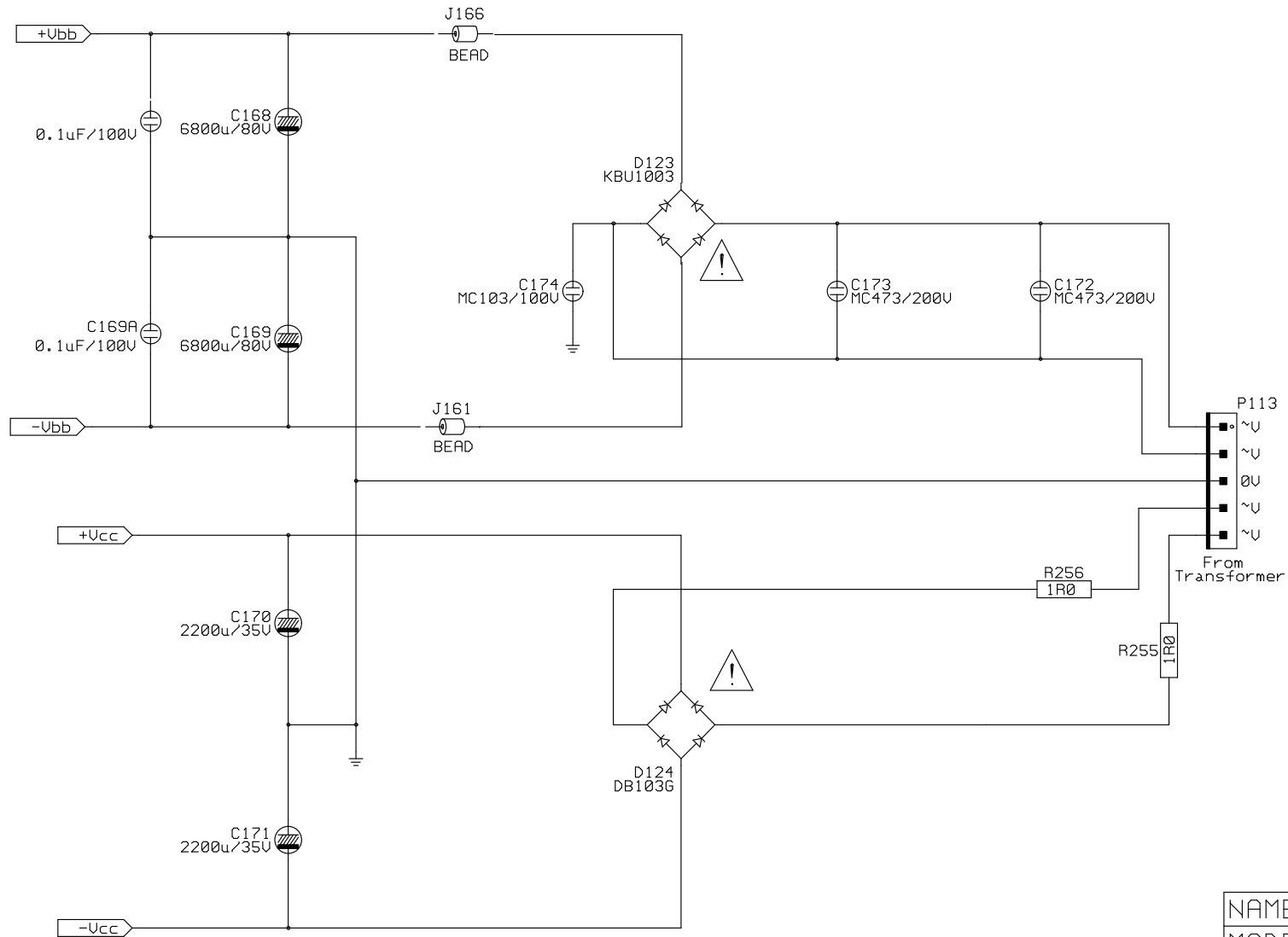

NAME : DCPWR/Mother	10/12
MODEL : PSW310W/120	REV:A0
CUSTOMER : Infinity	
DATE : 2008-04-23	
APPROVE BY	CHECK BY
DRAWING BY	

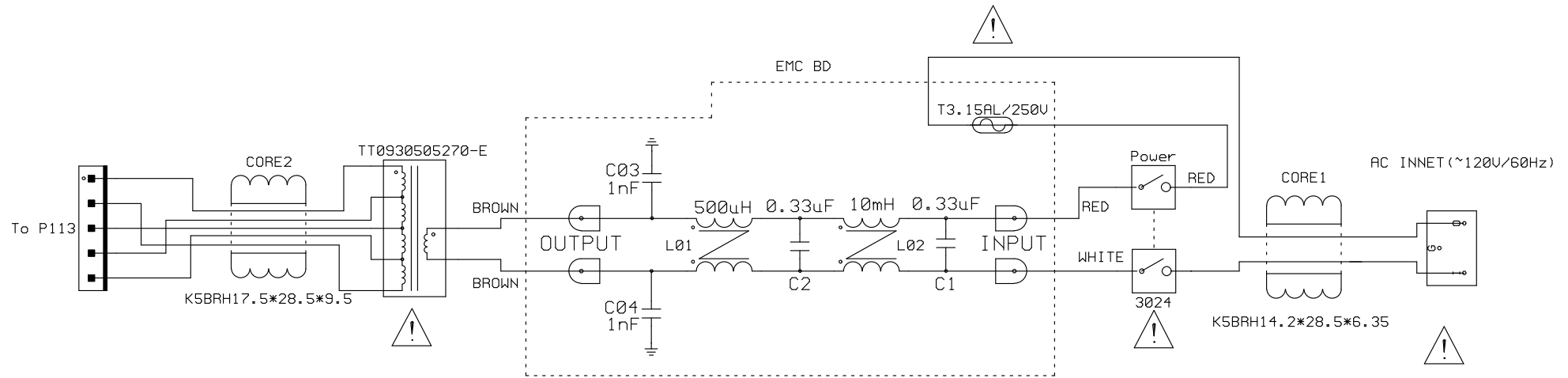

APPROVE BY	CHECK BY	DRAWING BY	NAME : AC INNET	12/12
			MODEL : PSW310W/120	REV:A0
			CUSTOMER : Infinity	
			DATE : 2008-04-24	

PSW310W subwoofer Classia Series

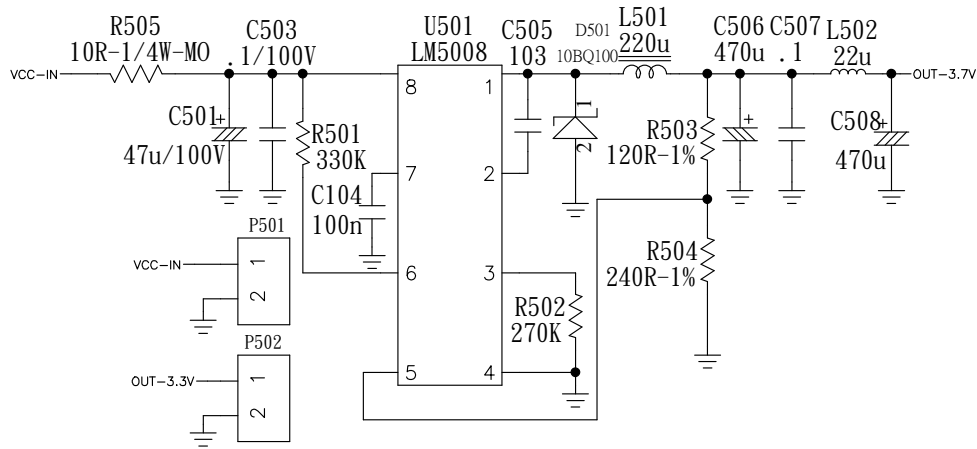

Draw.

Dsgn.

Apvd.

Filename	DC-DC
Model No.	PSW310W 120V
Drawn by	HUAIJIAN 51
Date	2008-04-24

Rev	A0
1	PAGE:1/12
2	CUSTOMER:Infinity
3	

Size A4

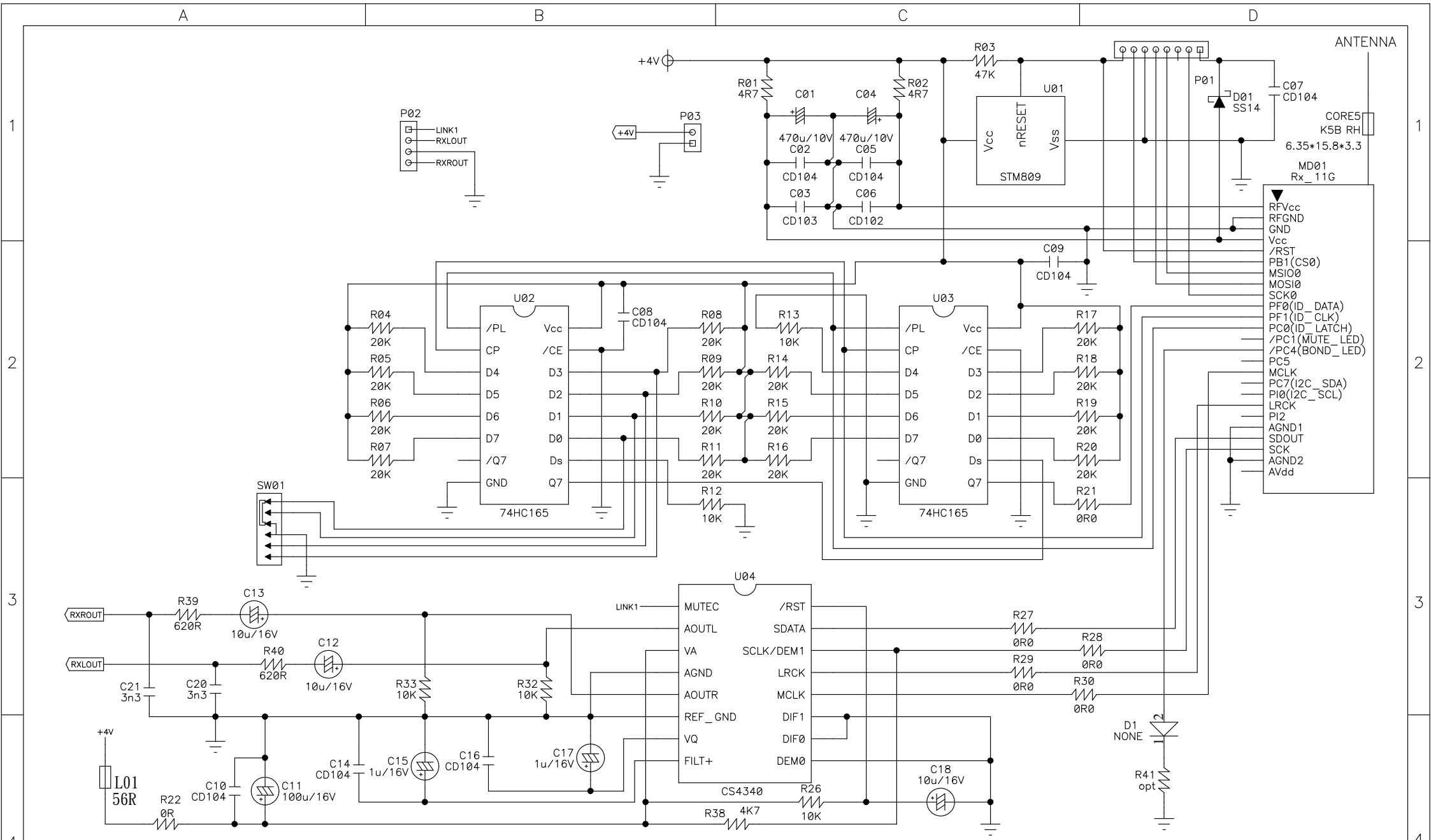

ANTENNA

RFVcc
RFGND
GND
Vcc
/RST
PB1(CS0)
MSIO0
MOSI0
SCK0
PF0(ID_DATA)
PF1(ID_CLK)
PC0(ID_LATCH)
/PC1(MUTE_LED)
/PC4(BOND_LED)
PC5
MCLK
PC7(I2C_SDA)
PI0(I2C_SCL)
LRCK
PI2
AGND1
SDOUT
SCK
AGND2
AVdd

Draw.

Dsgn.

Apvd.

Filename	Wireless	Rev	A0	Size	A4
Model No.	PSW310W 120V	1	PAGE:2/12		
Drawn by	HUAIJIAN 52	2	CUSTOMER:Infinity		
Date	2008-04-24	3			

PSW310W subwoofer Classia Series

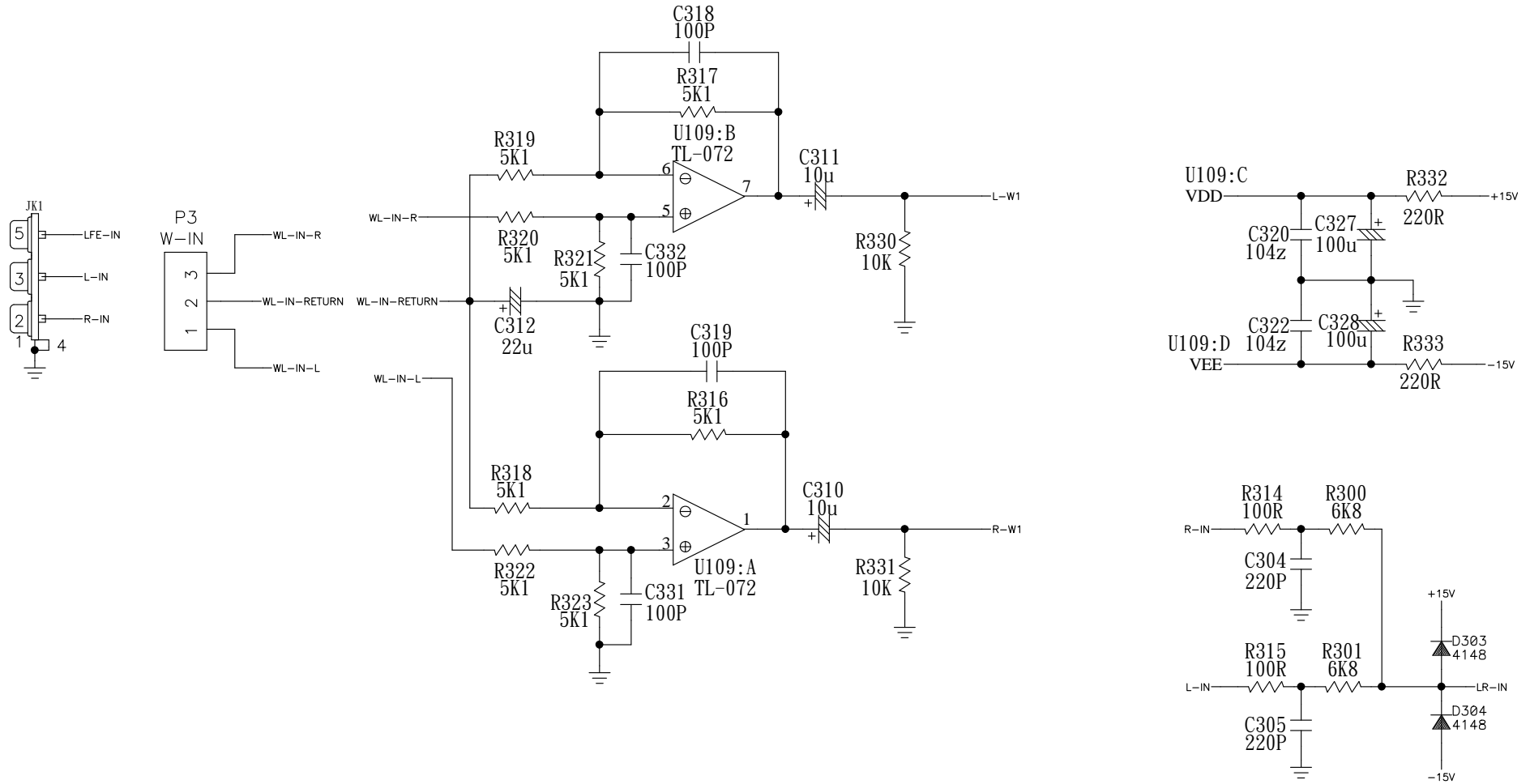

Draw.

Dsgn.

Apvd.

Filename	MIX	Rev	A0	Size	A4
Model No.	PSW310W 120V	1	PAGE:3/12		
Drawn by	HUAJIAN 53	2	CUSTOMER:Infinity		
Date	2008-04-24	3			

PSW310W subwoofer Classia Series

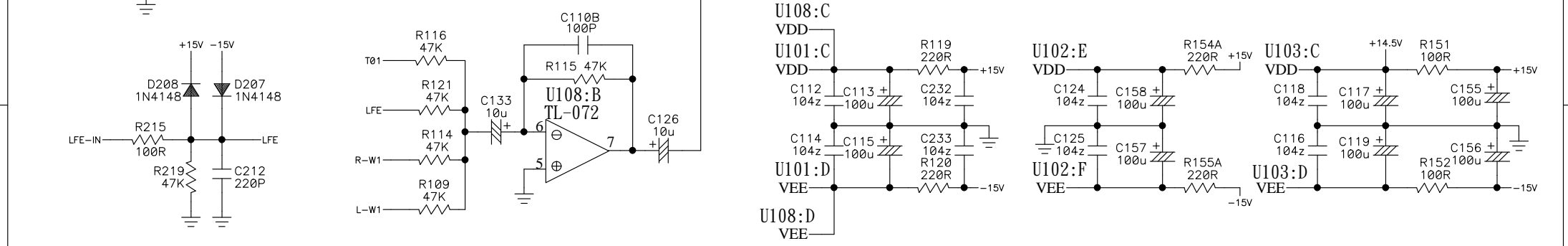
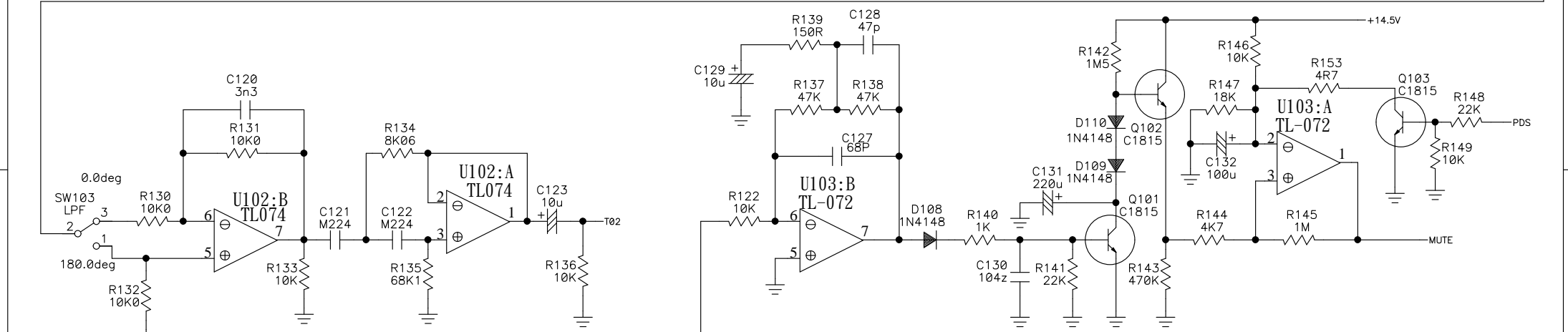
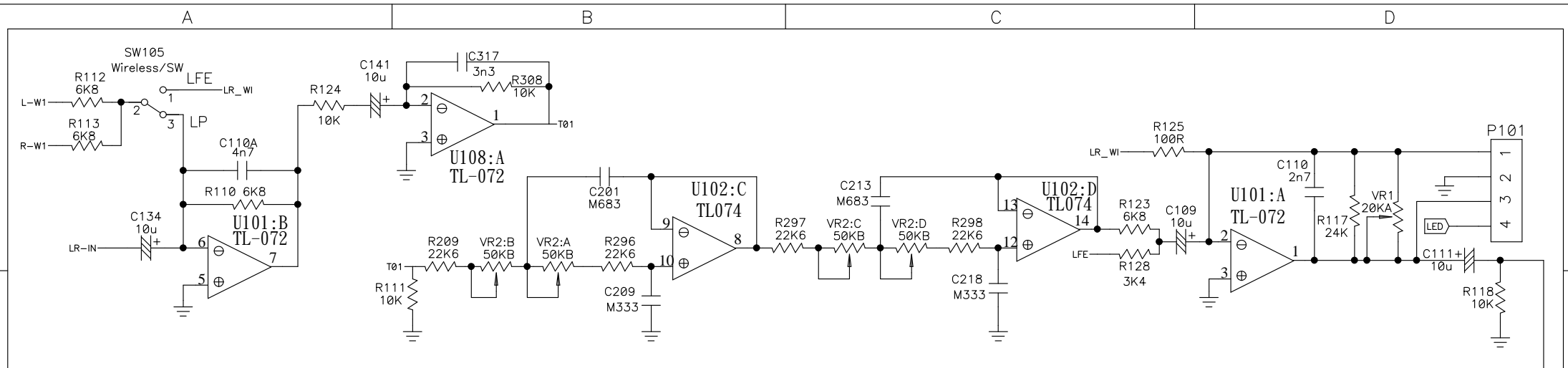

Draw.	Dsgn.	Apvd.	Filename PRE	Rev A0	Size A4
			Model No. PSW310W 120V	1 PAGE:4/12	
			Drawn by HUAJIAN 54	2 COSTOMER:Infinity	
			Date 2008-04-24	3	

PSW310W subwoofer Classia Series

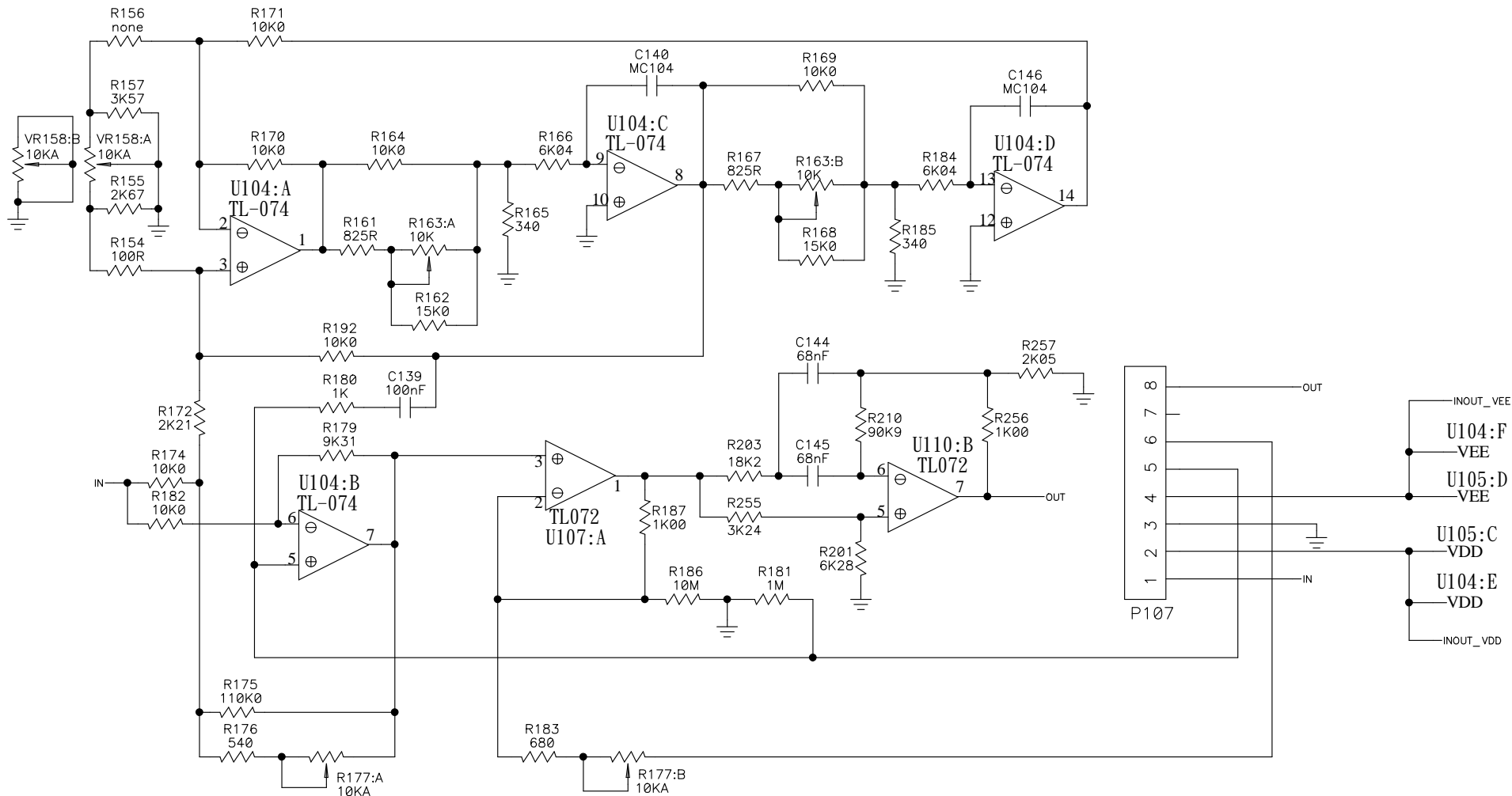

Drawn by

Dsgn.

Apvd.

Filename	IN/OUT	Rev	A0	Size	A4
Model No.	PSW310W 120V	1	PAGE:5/12		
Drawn by	HUAJIAN 55	2	CUSTOMER:Infinity		
Date	2008-04-24	3			

PSW310W subwoofer Classia Series

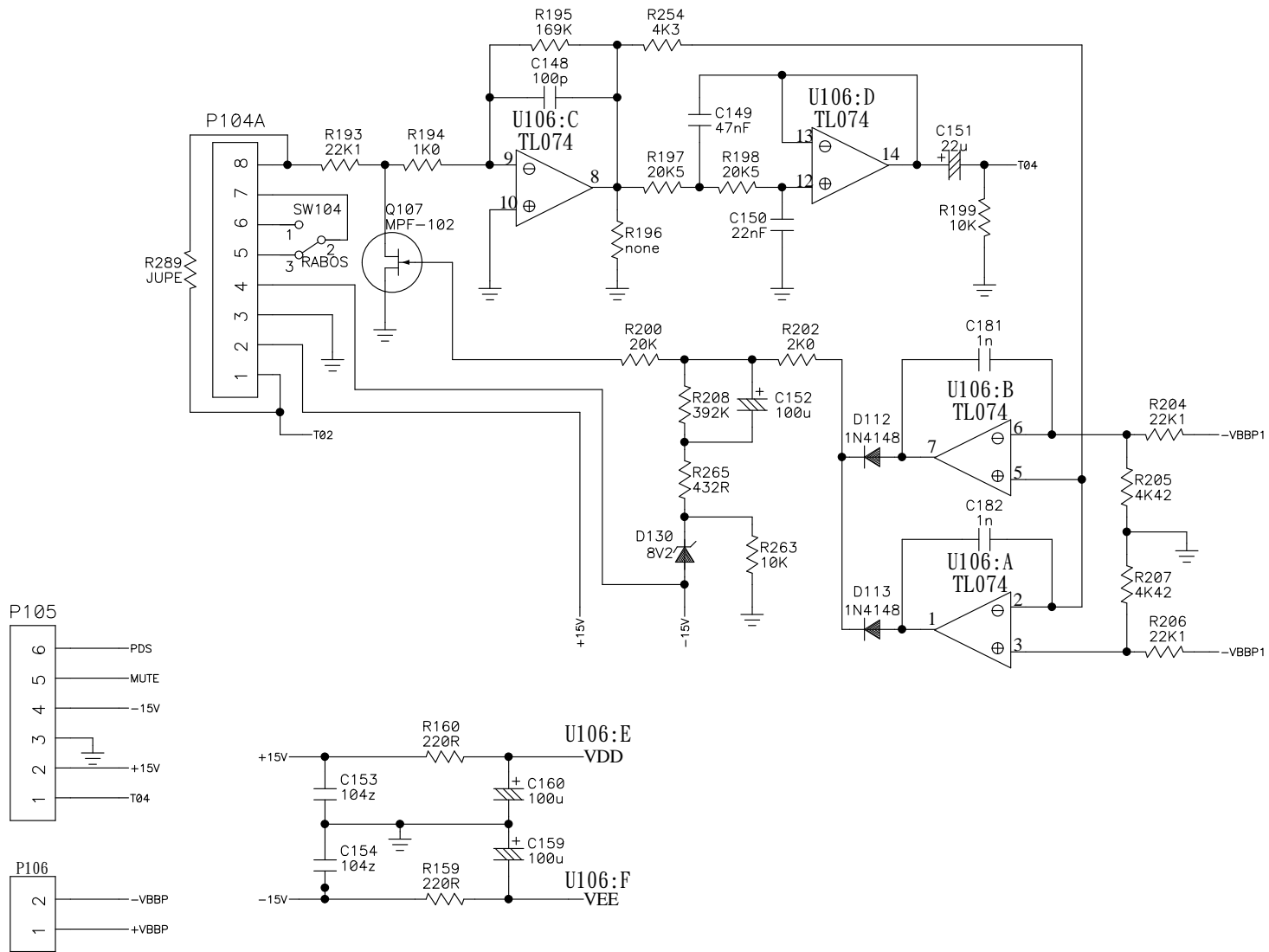

Draw. _____
 Dsgn. _____
 Apvd. _____

Filename	Limiter	Rev	A0	Size	A4
Model No.	PSW310W 120V	1	PAGE:6/12		
Drawn by	HUAJIAN 56	2	CUSTOMER:ifinity		
Date	2008-04-24	3			

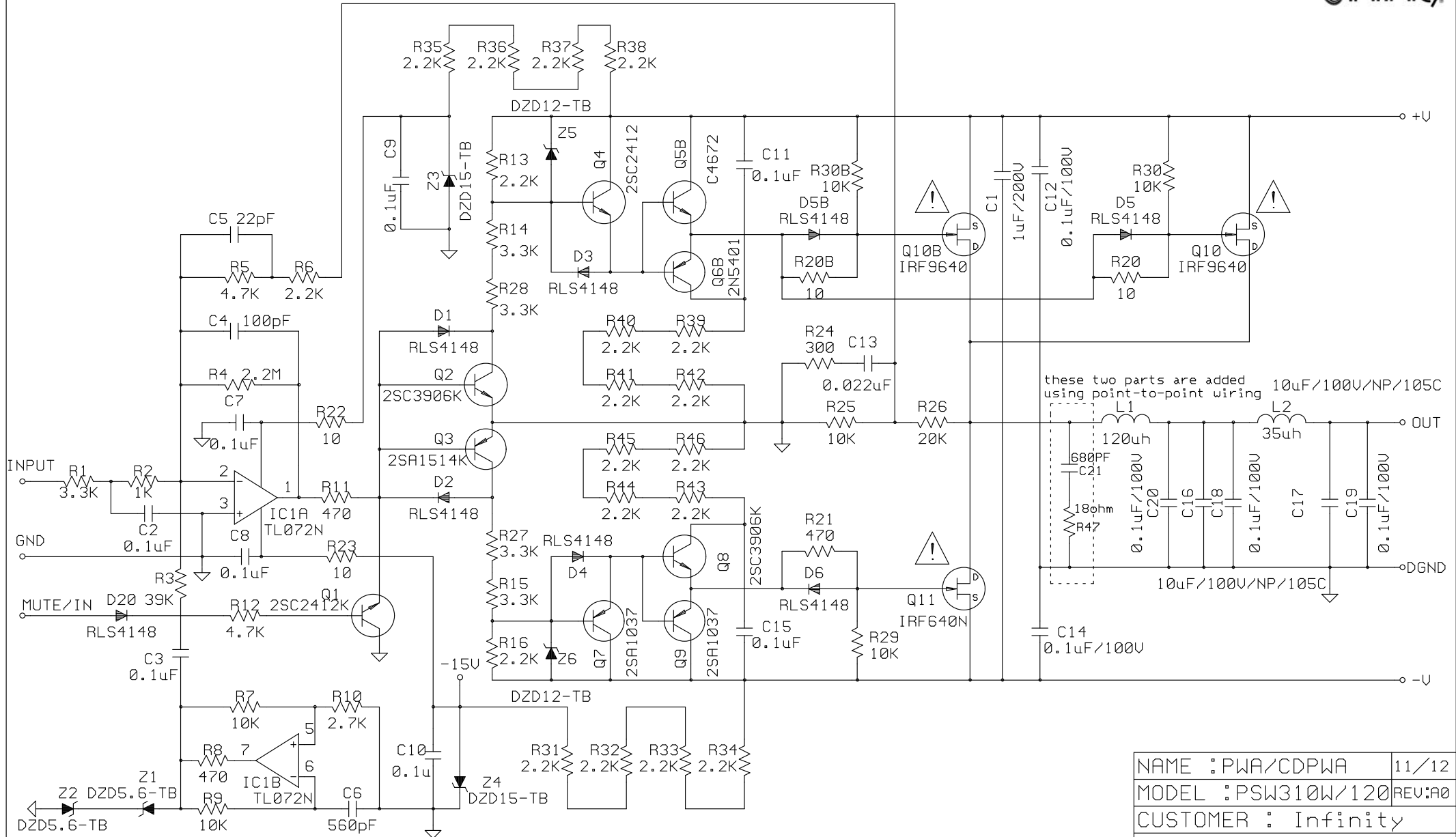

NAME : PWA/CDPWA	11/12
MODEL : PSW310W/120	REV:A0
CUSTOMER : Infinity	
DATE : 2008-04-24	
APPROVE BY	CHECK BY DRAWING BY