



TSS-Sub500 (TSS-500 SYSTEM)

SERVICE MANUAL



Note: The TSS-Sub500 is part of the TSS-500 system

Satellite loudspeakers:
(Charcoal) order Infinity part# TSS-SAT500CHR
(Platinum) order Infinity part# TSS-SAT500PLT
Center channel: Call Infinity Systems parts department
(Charcoal) (Platinum)

CONTENTS

BASIC SPECIFICATIONS 1
 PACKAGING/ACCESSORIES. 2
 DETAILED SPECIFICATIONS 3
 CONTROLS. 5
 CONNECTIONS 6
 OPERATION..... 7
 EXPLODED VIEW-MECHANICAL PARTS LIST.....8
 TEST SET-UP/PROCEDURE. 9
 BLOCK DIAGRAM. 10
 TROUBLESHOOTING FLOW CHART.....11
 PCB DRAWINGS.12
 ELECTRICAL PARTS LIST 20
 IC – TRANSISTOR PINOUTS 24
 SCHEMATIC DIAGRAMS 25

TSS-Sub500 Specifications

Frequency Range:	39Hz – 150Hz (±3dB)
Amplifier Output:	100 watts RMS
Low-Frequency Driver:	8" (203mm)
Crossover Frequency:	120Hz, 24dB/Octave (line-level [non-LFE] input)
Dimensions (H x W x D):	15-7/8" x 13-5/8" x 14-5/8" (403mm x 346mm x 371mm)
Weight:	31.7 lb (14.4kg)

Infinity continually strives to update and improve existing products, as well as create new ones. The specifications and construction details in this and related Infinity publications are therefore subject to change without notice.

TSS-500 PACKING/ACCESSORIES

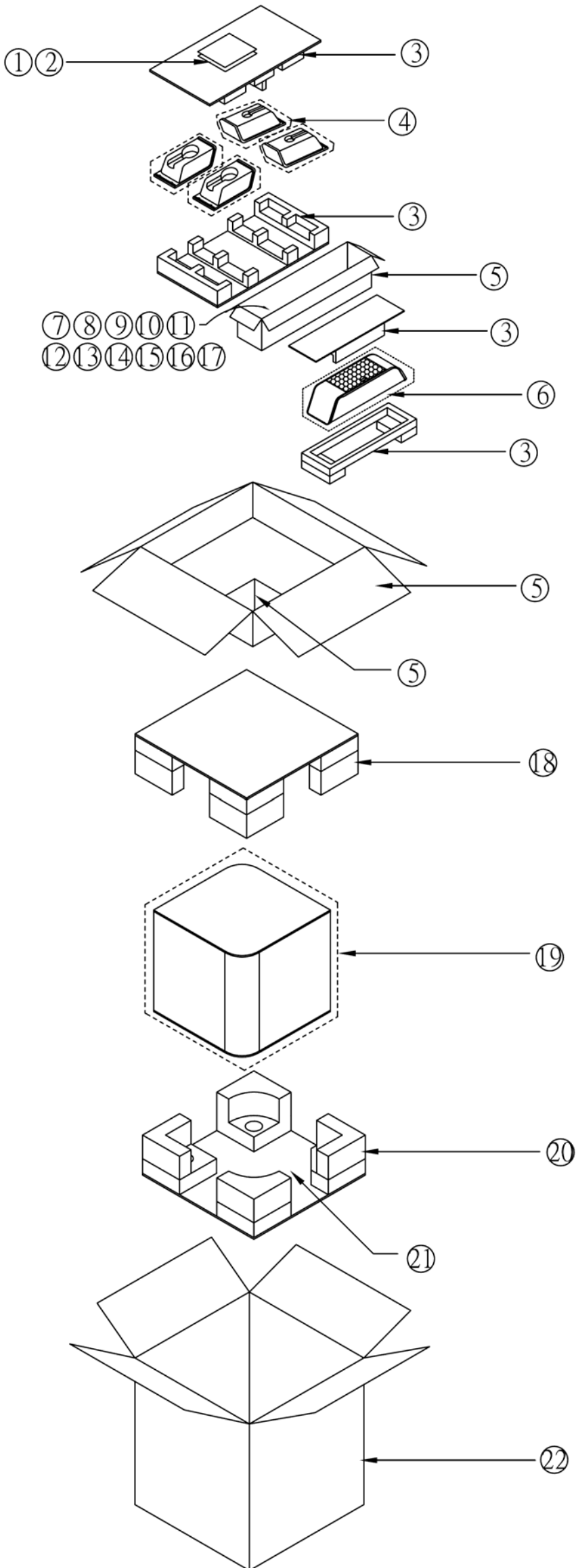

Item #	Description	Part Number	Qty
1	Warranty Card	405-000-05110-E	1
2	Owner's Manual	406-000-05307-E	1
3	Packing	Not for Sale	1
4	Packing Bag	Not for Sale	4
5	Inner Carton	Not for Sale	1
6	Packing Bag	Not for Sale	1
7	Nut wrench (metal bar)	399-FE-00630-E	1
8	15' RCA cable	370-000-00273-E	1
9	Rubber feet for stands (Platinum)	373-000-05051-E	1
	Rubber feet for stands (Charcoal)	373-000-05050-E	1
10	Screw for stands (5) ¼ x 20 x1" (Platinum)	371-000-05108-E	1
	Screw for stands (5) ¼ x 20 x1" (Charcoal)	371-000-05114-E	1
11	Wall Bracket ball end (5) (Platinum)	373-000-05054-E	1
	Wall Bracket ball end (5) (Charcoal)	373-000-05055-E	1
12	40' Wire set (2)	370-000-00276G-E	2
13	20' Wire set (3)	370-000-00277G-E	3
14	Satellite stand (Platinum)	325-ABS-05126-0VAE	4
	Satellite stand (Charcoal)	325-ABS-05127-0BAE	4
15	Wall bracket	398-ABS-00317-0VAE	5
16	Center table stand (Platinum)	325-ABS-05127-0VAE	1
	Center table stand (Charcoal)	325-ABS-05126-0BAE	1
17	Rubber gasket for stand	336-RUB-05200-0VAE	1
18	Subwoofer Top Packing	431-000-05639-E	1
19	Packing Bag	Not for Sale	1
20	Subwoofer Btm Packing	431-000-05640-E	1
21	Desiccant	Not for Sale	3
22	Outer Carton (Platinum)	402-000-05533-E	1
	Outer Carton (Charcoal)	402-000-05534-E	1

TSS-Sub500		100W Powered Sub/ Plate Amp				
LINE VOLTAGE	Yes/No	Hi/Lo Line	Unit	Notes		
US 120VAC/60Hz	Yes	108-132	Vrms	Normal Operation		
Europe 220-240VAC, 50-60Hz	Yes	220-240	Vrms	Normal Operation		
Parameter	Specification	Unit	QA Test Limits	Conditions	Notes	
Amp Section						
Type (Class AB, D, other)	AB	AB	n/a	120V Model	External Sink required	
Type (Class AB, D, other)	G	G	n/a	230V Model	External Sink required	
Load Impedance (speaker)	4	Ohms	n/a	Nominal		
Rated Output Power	100	Watts	95	Single input driven		
THD@ Rated Power	0.5	%	1	22K filter		
THD @ 1 Watt	0.1	%	0.5	22K filter		
DC Offset	10	mV-DC	50	@ Speaker Output		
Damping factor	>100	DF	100	50Hz, 4 Ohms load	Measured at amplifier board speaker output terminals, Output power 90 Watts	
Input Sensitivity						
Input Frequency	50	Hz	50	Nominal Freq.		
Line Input (L&R)	13.8	mVrms	±2dB	To 1 Watt	Single input driven, AP Zo=600 Ohms	
LFE Input	8.62	mVrms	±2dB	To 1 Watt	LFE input driven only, AP Zo=600 Ohms	
Signal to Noise						
SNR-A-Weighted	100	dBa	85	rel. to rated power	A-Weighting filter	
SNR-unweighted	80	dBr	80	rel. to rated power	22K filter	
SNR @ 1W-unweighted	60	dBr	60	rel. to 1W Output	22K filter	
Residual Noise Floor	1	mVrms	2	Volume @max, using RMS reading DMM/VOM (or A/P)		
Residual Noise Floor	1	mVrms(max)	2	Volume @max, w/ A/P Swept Bandpass Measurement (Line freq.+ harmonics)		
Input Impedance						
Line input L&R , LFE	>10	K ohms	n/a	Nominal		
Filters						
Low Pass (fixed or variable)	4th order fix	--	±2dB			
Subsonic filter (HPF)	2nd order	Hz	±2dB			
Limiter (yes/no)						
THD at Max. Output Power	YES	--	Functional			
THD at Max. Output Power	1	%	Functional			
Features						
LFE Input	YES	--	Functional			
Volume pot Taper (lin/log)	LOG	--	Functional			
ATO	YES	--	Functional			
Input Configuration						
Line In (L,R)	L ,R	--	Functional	RCA inputs		
Line level in LFE	LFE	--	Functional			
Signal Sensing (ATO)						
Auto-Turn-On (yes/no)	YES	--	Functional			
ATO Input Frequency	50	Hz	Functional			
ATO Level	2	mV	Functional	2mV@50Hz into Line Input w/ 1 ch. driven		
ATO Turn-on time	5	ms	Functional	Amp connected and AC on, then input signal applied		
Auto Mute/ Turn-OFF Time	10	minutes	Functional	T before muting, after signal is removed		Auto turn of time (T) must be 5 > T <15
Power on Delay time	3	sec.	Functional	AC Power Applied		
Transients/Pops						
ATO Transient	5	mV-peak	10	Speaker Outputs		
Turn-on Transient	50	mV-peak	100	Speaker Output		AC Line cycled from OFF to ON
Turn-off Transient	50	mV-peak	100	Speaker Output		AC Line cycled from ON to OFF
Efficiency						
Stand-by Input Power	12	Watts	15	@ nom. line voltage		
Power Cons.@rated power	195	Watts	210	@ nom. line voltage		
				100 Watts @ 4 Ohms nominal line voltage		

Parameter	Specification	Unit	QA Test Limits	Conditions	Notes
Protection					
Short Circuit Protection	YES	--	Functional	Direct short at output	
Thermal Protection	65 deg. C	--	Functional	@1/8 max unclipped Power	Temperature rise should not exceed 35K rise
DC Offset Protection	YES	--	Functional	DC present at Speaker Out leads	Relay or crowbar (for driver/fire protection)
Line Fuse Rating					External fuse with UL/SEMKO rated holder
120 VAC	2.5	Amps		Type-T or Slo Blo, Fuse Markings T2.5A, 250V	
230 VAC	1.25	Amps		Type-T, Low breaking capacity, Fuse markings T1.25AL, 250V	



- 1 Subwoofer Level Control
- 2 LFE Input
- 3 Line-Level Inputs
- 4 Power Switch

SUBWOOFER CONTROLS

Rear Panel

A Few Suggestions

We recommend that you do not operate your speakers or subwoofer with the bass, treble and loudness controls set to full boost. This will place undue strain on your electronics and speakers and could damage them.

The volume control setting on your processor/preamp or receiver is not a specific indication of the overall loudness level of the speakers. The only important consideration is the loudness level at which the system can be played, regardless of where the volume control is set.

Always turn down the volume control setting on your processor/preamp or receiver when changing a cassette or CD, or switching inputs to AM or FM operation. Excessively loud transients (clicks or popping sounds) can damage the satellite speakers and possibly the subwoofer.

Important!

Whenever changing cables, pulling plugs, etc., ALWAYS TURN OFF ALL EQUIPMENT, including the subwoofer.

SUBWOOFER CONNECTIONS

If you have a Dolby® Digital or DTS® receiver/processor with a low-frequency-effects (LFE) or subwoofer output:

15' (4.6m) subwoofer cable included

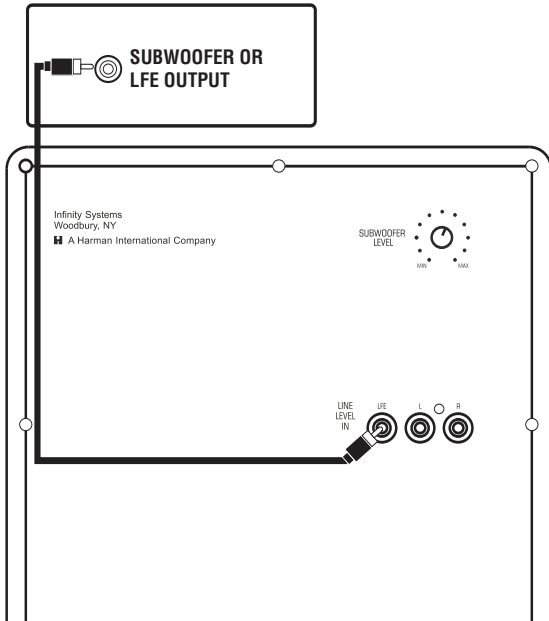

If your receiver/processor does not contain a Dolby Digital or DTS processor but has a subwoofer output:

15' (4.6m) subwoofer cable included

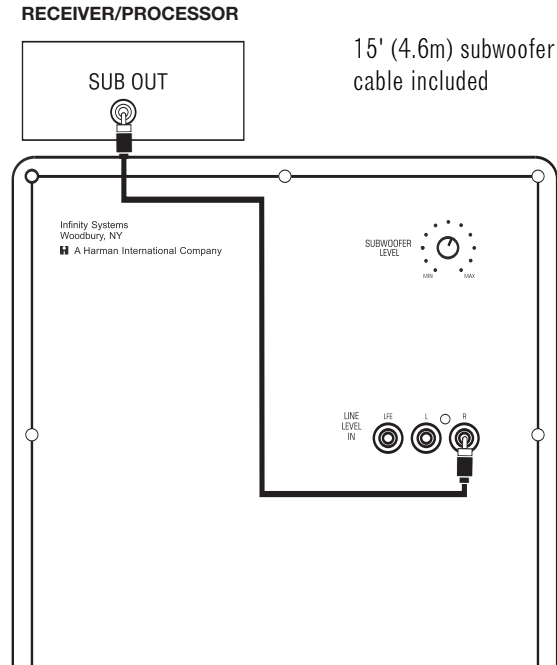

NOTE: If your receiver/processor has only one sub out, you may use either the L or R input.

OPERATION

Surround Modes

When using the TSS-500 in a Dolby Digital or DTS home theater system, make sure all speakers are set to "Small". When using the system in a Dolby Pro Logic® home theater system, make sure the receiver's center channel mode is set to "Normal".

Some Dolby Digital-equipped receivers/processors offer different setup options for each source or surround mode (e.g., CD-stereo, videotape, Dolby Digital, Pro Logic). In each case, follow your equipment's instructions to ensure that the subwoofer output is turned on and that the speakers are set to "Small" in each mode.

If your receiver has adjustable crossover settings, we recommend the subwoofer crossover be set between 100Hz and 120Hz.

Power On

Plug your subwoofer's AC cord into a wall outlet. Do not use the outlets on the back of the receiver.

Initially set the Subwoofer Level Control **1** to the "MIN" position.

Turn on the subwoofer by pressing the Power Switch **4** on the rear panel.

Turn on your entire audio system and start a CD or movie soundtrack at a moderate level.

Auto On/Standby

With the Power Switch **4** in the ON position, the LED on the back will remain lit in green or red to indicate the ON/STANDBY mode of the subwoofer.

RED = STANDBY (No signal detected, Amp Off)

GREEN = ON (Signal detected, Amp On)

The subwoofer will automatically enter the Standby mode after approximately 10 minutes when no signal is detected from your system. The subwoofer will then power ON instantly when a signal is detected. During periods of normal use, the Power Switch **4** can be left on. You may turn off the Power Switch **4** for extended periods of nonoperation, e.g., when you are away on vacation.

Adjust Level

Turn the Subwoofer Level Control **1** up about halfway. If no sound emanates from the subwoofer, check the AC-line cord and input cables. Are the connectors on the cables making proper contact? Is the AC plug connected to a "live" receptacle? Has the Power Switch **4** been pressed to the "On" position? Once you have confirmed that the subwoofer is active, proceed by playing a CD or DVD. Use a selection that has ample bass information.

Set the overall volume control of the receiver/processor to a comfortable level. Adjust the Subwoofer Level Control **1** until you obtain a pleasing blend of bass. Bass response should not overpower the room but rather be adjusted so there is a harmonious blend across the entire musical range. Many users have a tendency to set the subwoofer volume too loud, adhering to the belief that a subwoofer is there to produce lots of bass. This is not entirely true. A subwoofer is there to

enhance bass, extending the response of the entire system so the bass can be felt as well as heard. However, overall balance must be maintained or the music will not sound natural. An experienced listener will set the volume of the subwoofer so its impact on bass response is always there but never obtrusive.

Final Positioning

After correctly connecting the TSS-500 system and verifying that both the subwoofer and all satellite speakers are playing, it is time to optimize the system for your particular listening room. Earlier, you placed the subwoofer in its general location. Finding the exact location for optimum performance sometimes only involves moving the speakers up to a few inches in any direction. We urge you, therefore, to experiment with placement, if possible, until your speakers deliver their full potential.

MAINTENANCE AND SERVICE

The satellite and subwoofer enclosures may be cleaned using a soft cloth to remove fingerprints or to wipe off dust.

All wiring connections should be inspected and cleaned or remade periodically. The frequency of maintenance depends on the metals involved in the connections, atmospheric conditions and other factors, but once per year is the minimum.

If a problem occurs, make sure that all connections are properly made and clean. If a problem exists in one loudspeaker, reverse the connection wires to the left and right system. If the problem remains in the same speaker, then the fault is with the loudspeaker. If the problem appears in the opposite speaker, the cause is in another component or cable. In the event that your TSS-500 ever needs service, contact your local Infinity dealer or visit www.infinitysystems.com for a service center near you.

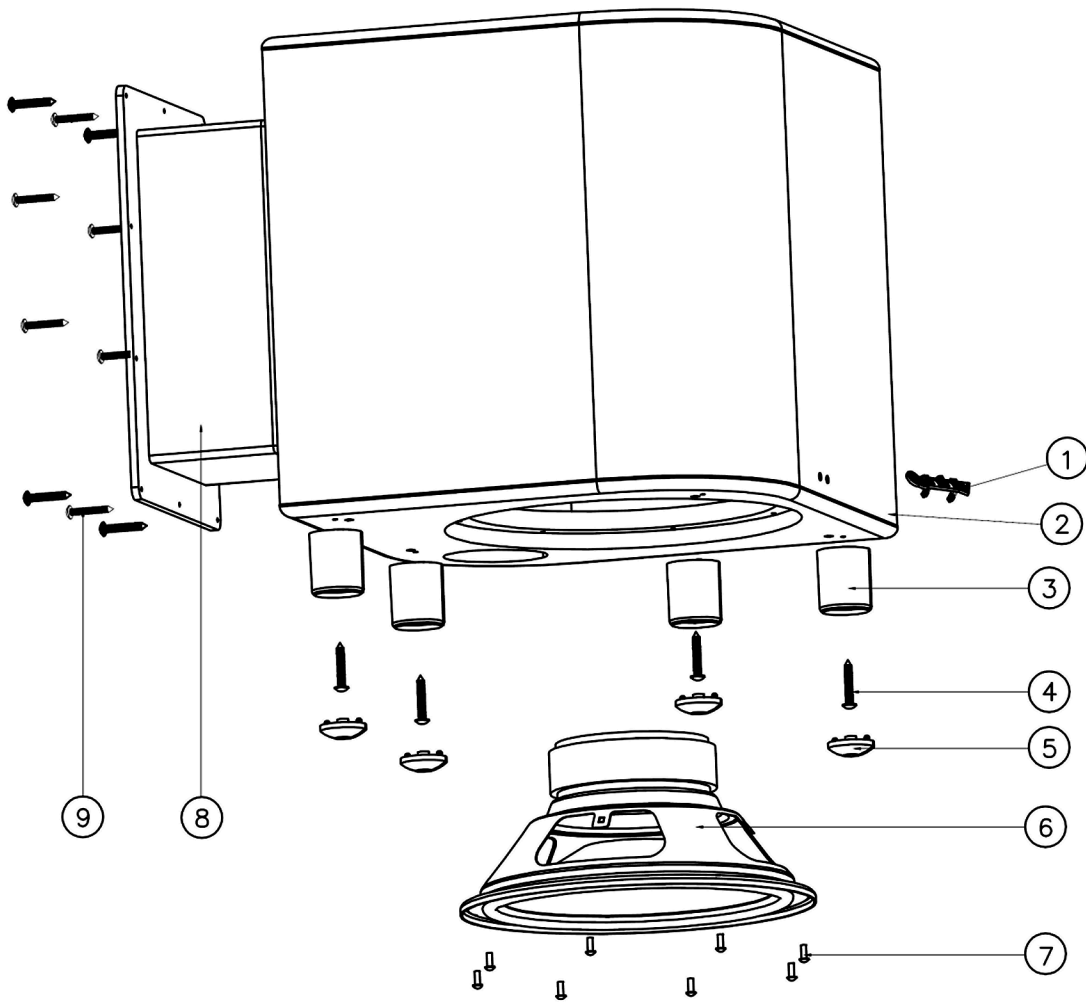

Item No.	Description	Part Number	Qty
1	Infinity Logo	316-ABS-00550-E	1
2	TSS-500 Cabinet	Not for Sale	1
3	Feet (Main,Plastic) Platinum	321-ABS-05055-0AAE	4
	Feet (Main Plastic) Charcoal	321-ABS-05055-0BAE	4
4	Foot Screw	352-HM04070D998-E	4
5	Rubber Foot Pad	320-RUB-05051-0BAE	4
6	10" Woofer DCR = 3.3Ω	20MF10DAG-DW01	1
7	Woofer Screw - Platinum	352-FM04020D605	8
	Woofer Screw - Charcoal	352-FM04020D605-E	8
8	TSS-500 Amplifier	Not for Sale	1
9	Amplifier Screws	352-AM04020D210-E	10

Test Set Up and Procedure

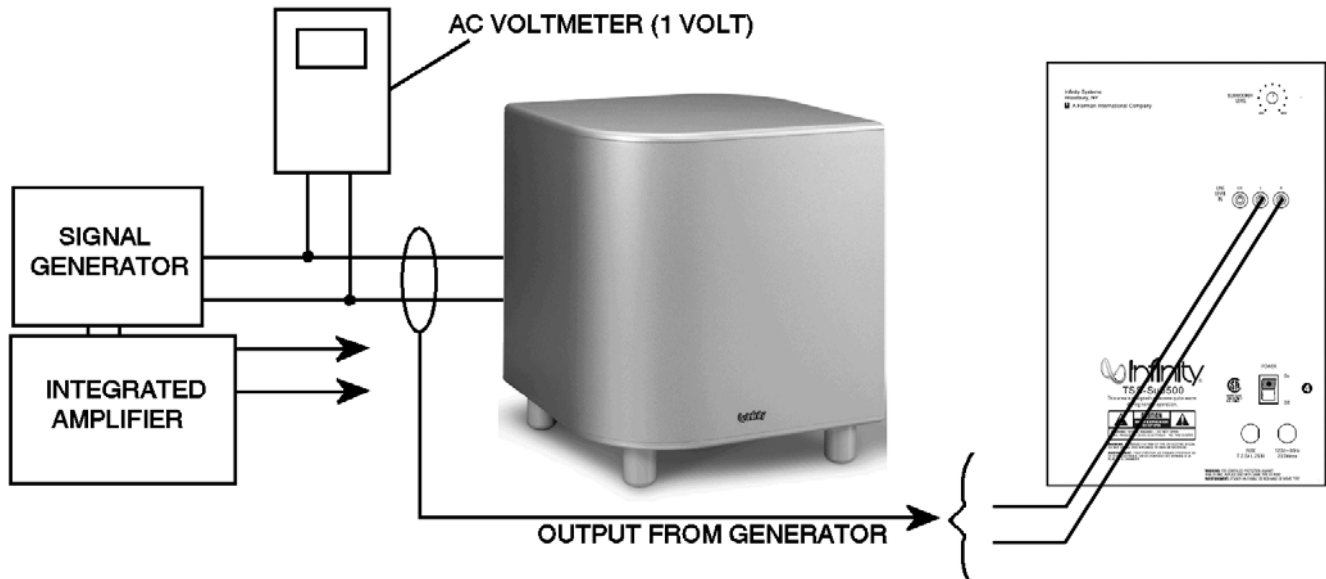

Equipment needed:

- Function/signal generator/sweep generator
- Integrated Amplifier
- Multimeter
- Speaker cables

General Unit Function (UUT = Unit Under Test)

- 1) From the signal generator, connect one line level (RCA) cable to the Subwoofer Line Level Input jacks L/R on the UUT. Use a Y-cable from a mono source if necessary to connect to both inputs. Do not connect to the single LFE input.
- 2) On the front of the unit, turn the LEVEL control full counterclockwise.
- 3) Turn on generator, adjust to **100mV, 50 Hz**.
- 4) Plug in UUT; turn the power switch ON. LED should be Red. Turn LEVEL control full clockwise (MAX)
- 5) LED should now be Green; immediate bass response should be heard and felt from port tube opening.
- 6) Turn off generator, turn LEVEL control fully counterclockwise, disconnect RCA cable.

Sweep Function

- 1) Follow steps 3-6 above, using a sweep generator as a signal source.
- 2) Sweep generator from 20Hz to 300Hz. Listen to the cabinet and drivers for any rattles, clicks, buzzes or any other noises. If any unusual noises are heard, remove woofers and test.

Driver Function

- 1) Remove woofer from cabinet; detach + and - wire clips.
- 2) Check DC resistance of woofer; it should be **3.3 ohms ±10%**
- 3) Connect a pair of speaker cables to driver terminals. Cables should be connected to an integrated amplifier fed by a signal generator. Turn on generator and adjust so that speaker level output is **5.0V**.
- 4) Sweep generator from 20Hz to 1kHz. Listen to driver for any rubbing, buzzing, or other unusual noises.

BLOCK DIAGRAM

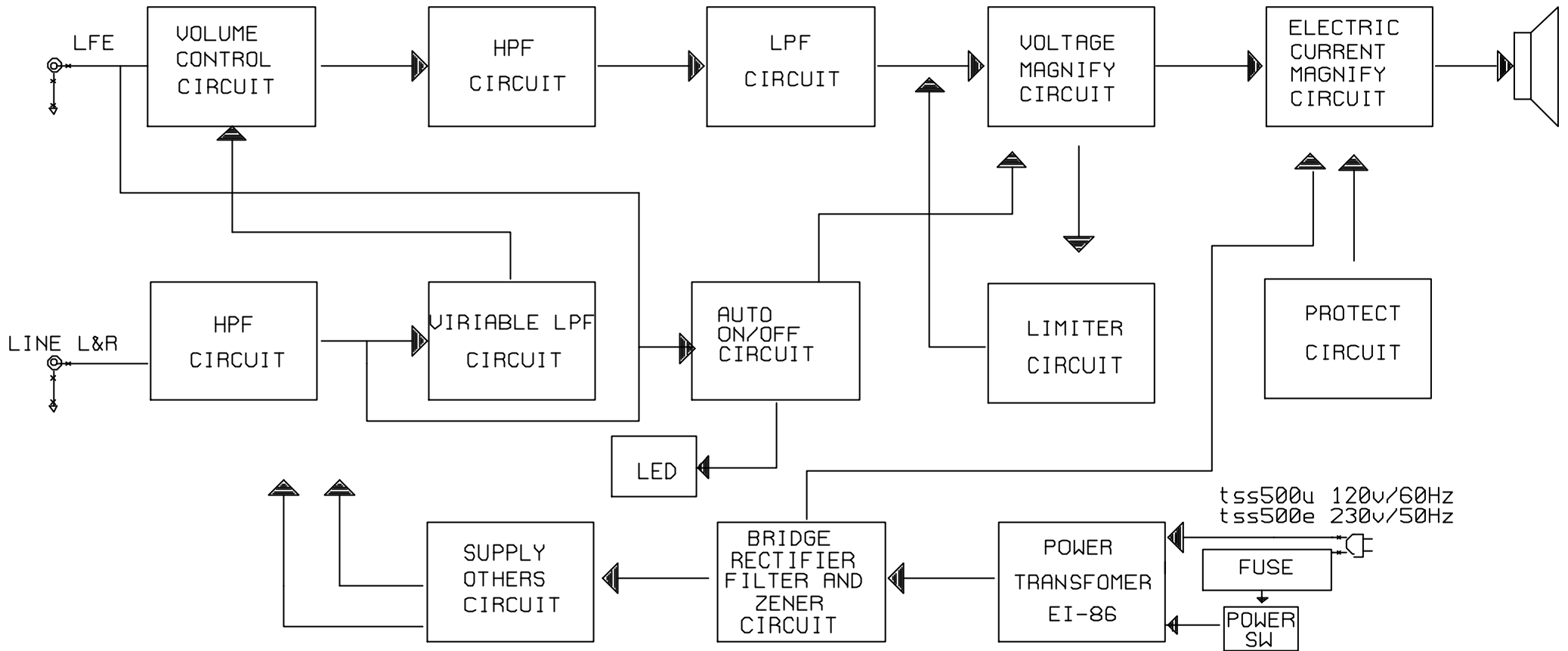

TSS500

Troubleshooting Flow Chart

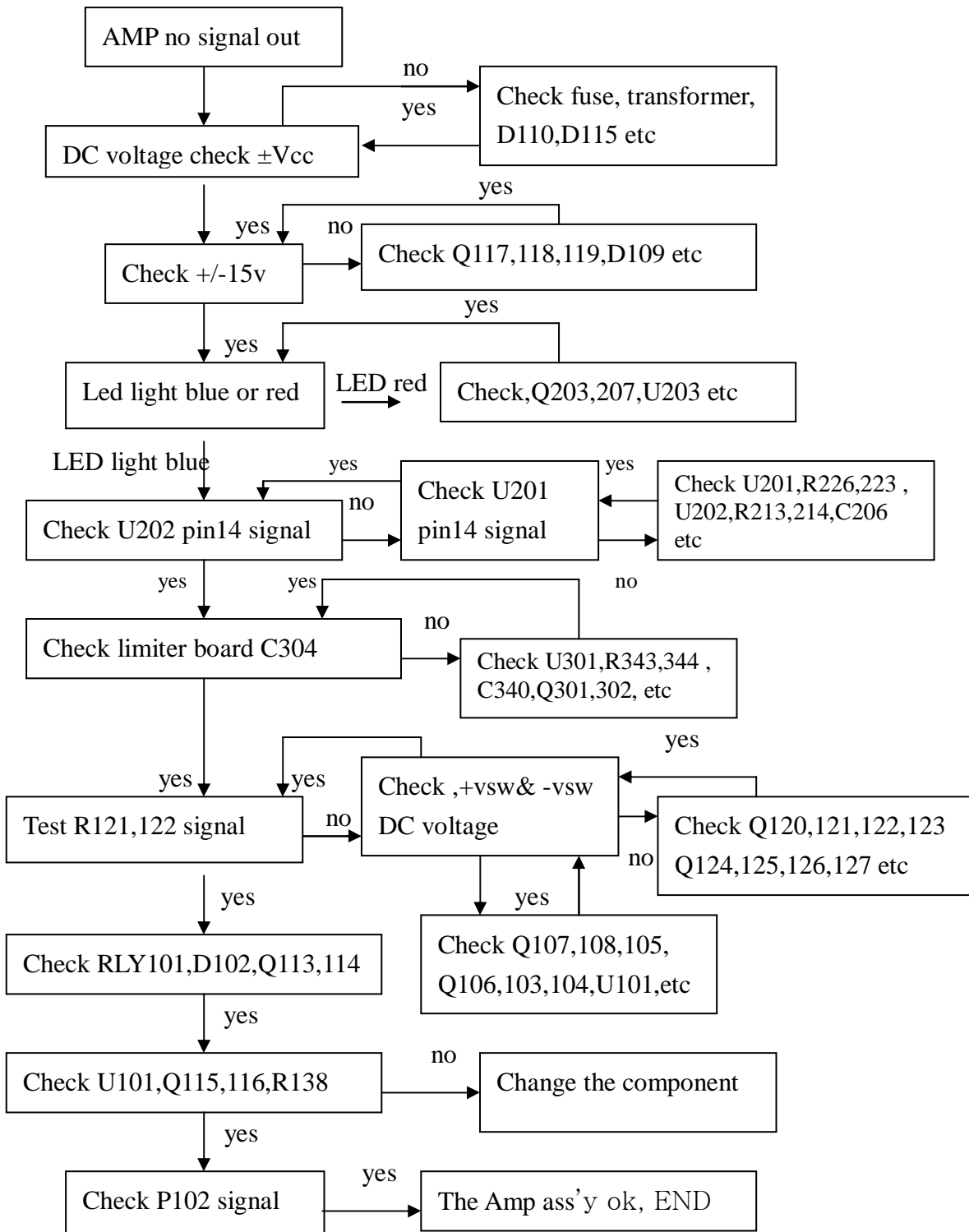

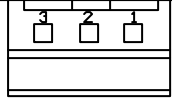

104-A00498A00V-E TSS500PRE BD VER:1.0

ML OCT.21.05

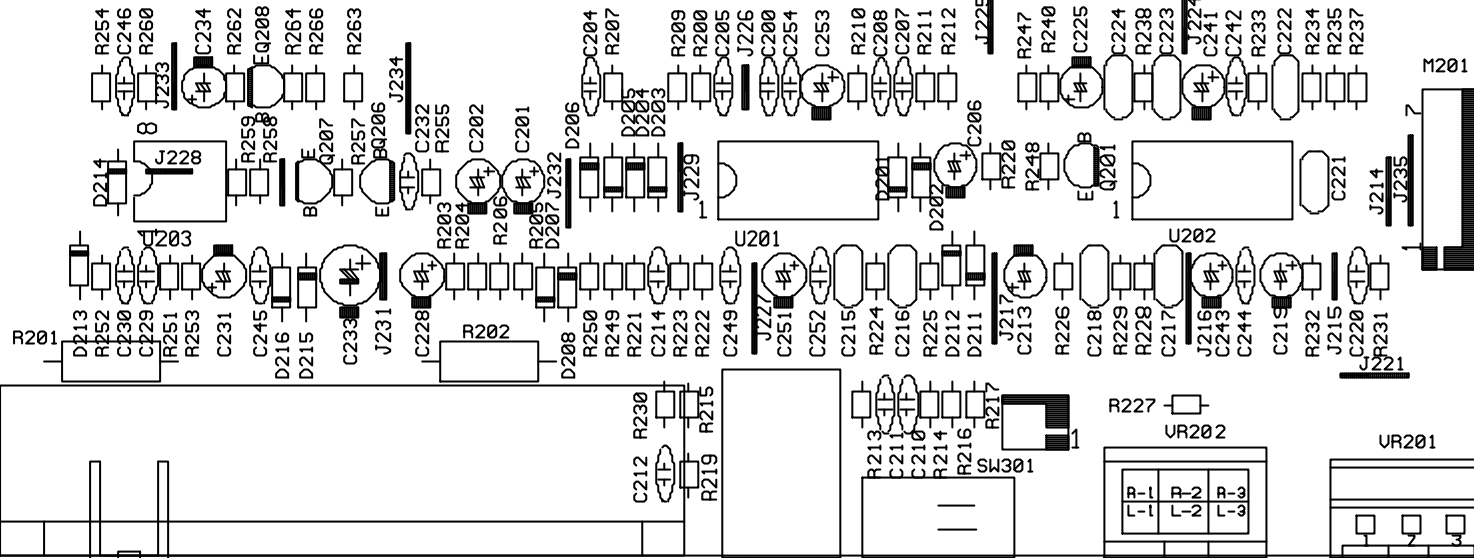

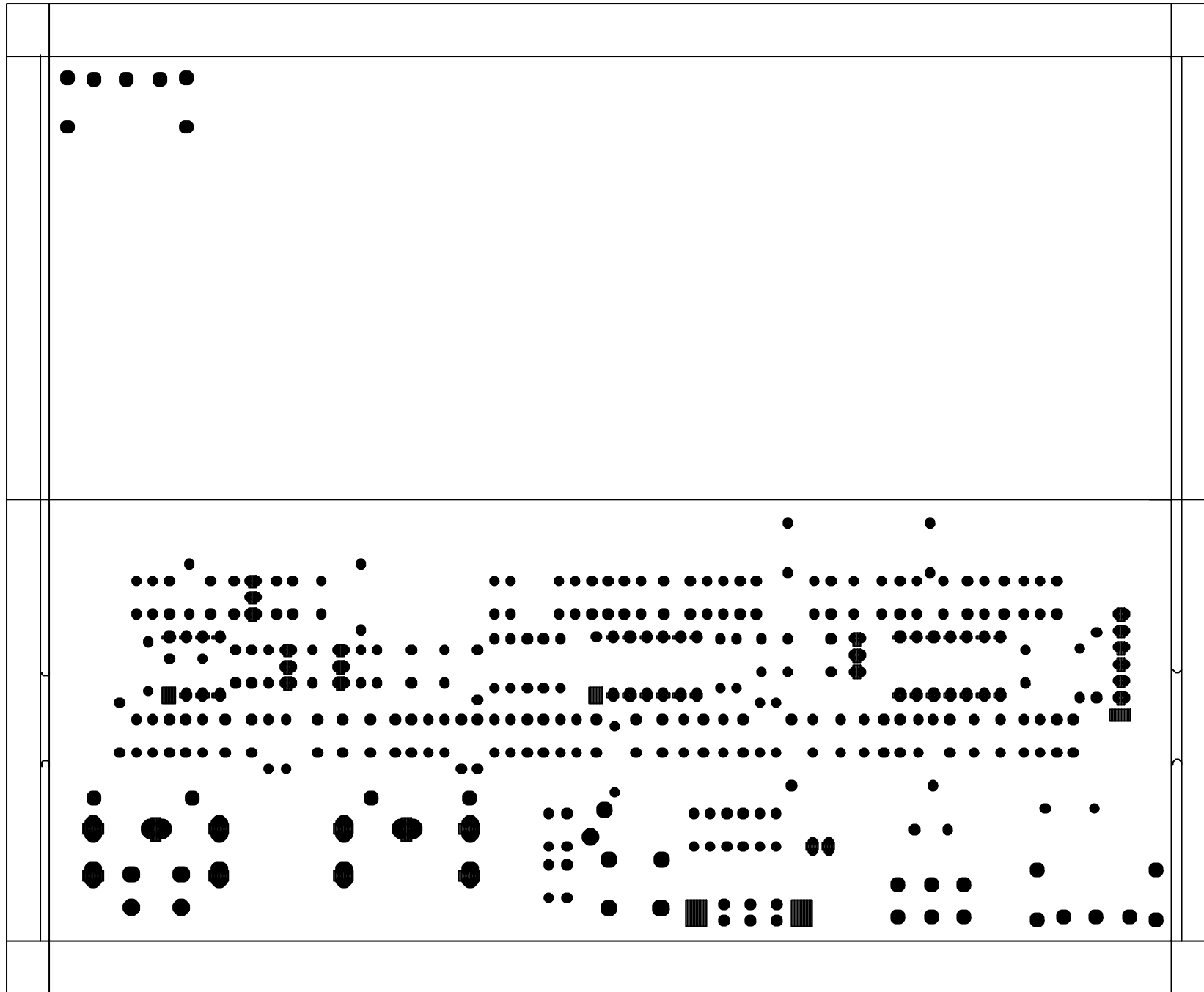

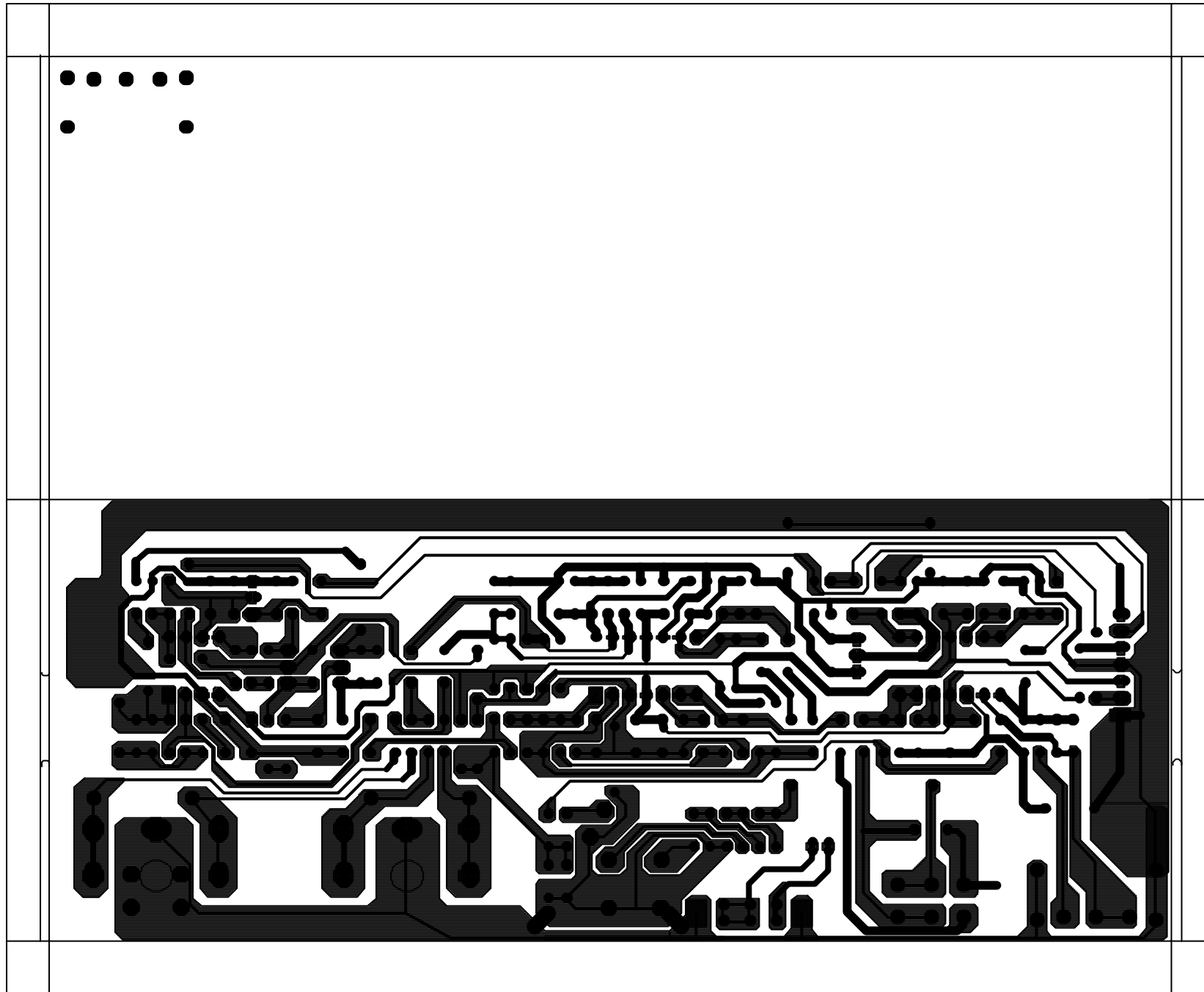

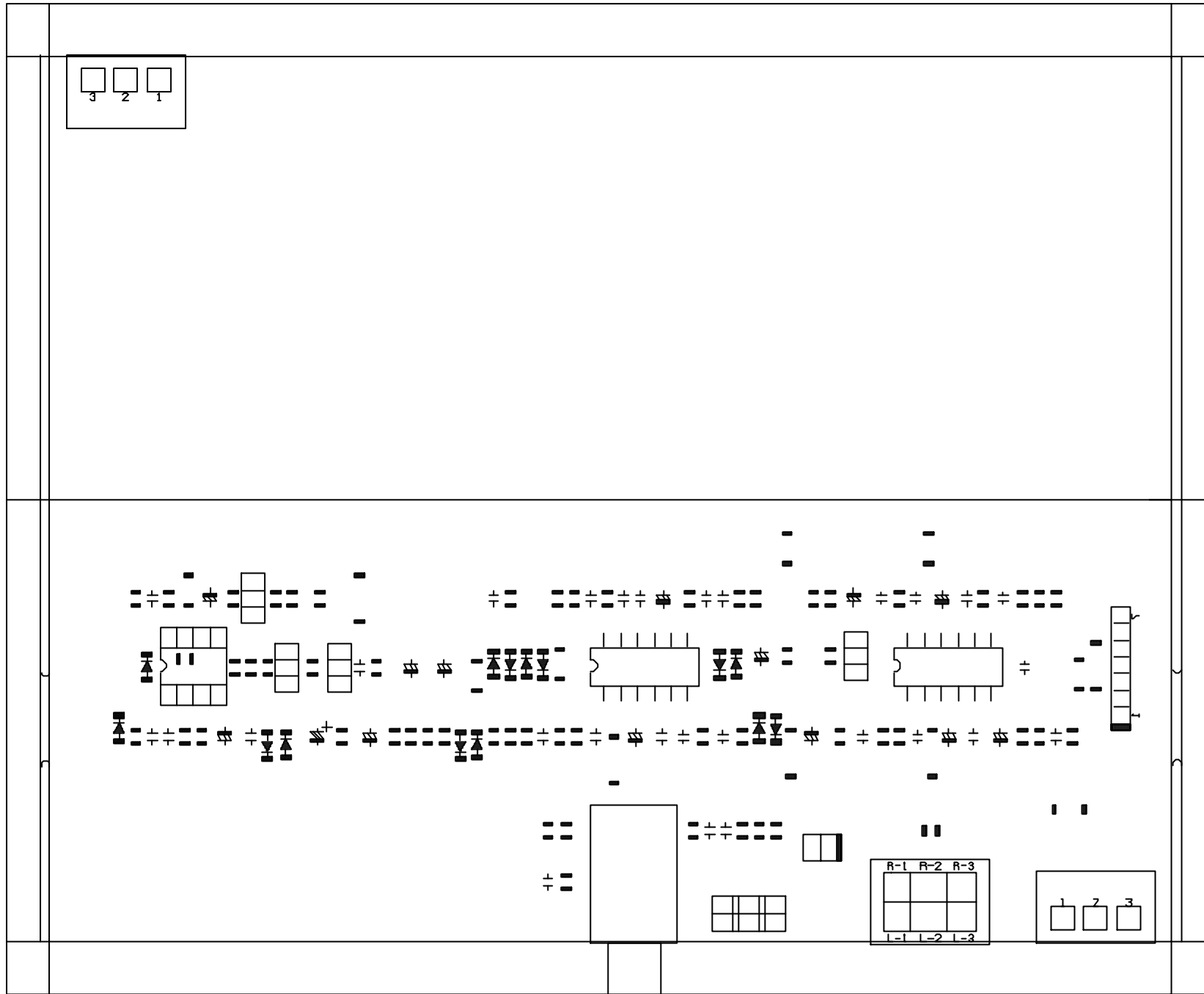

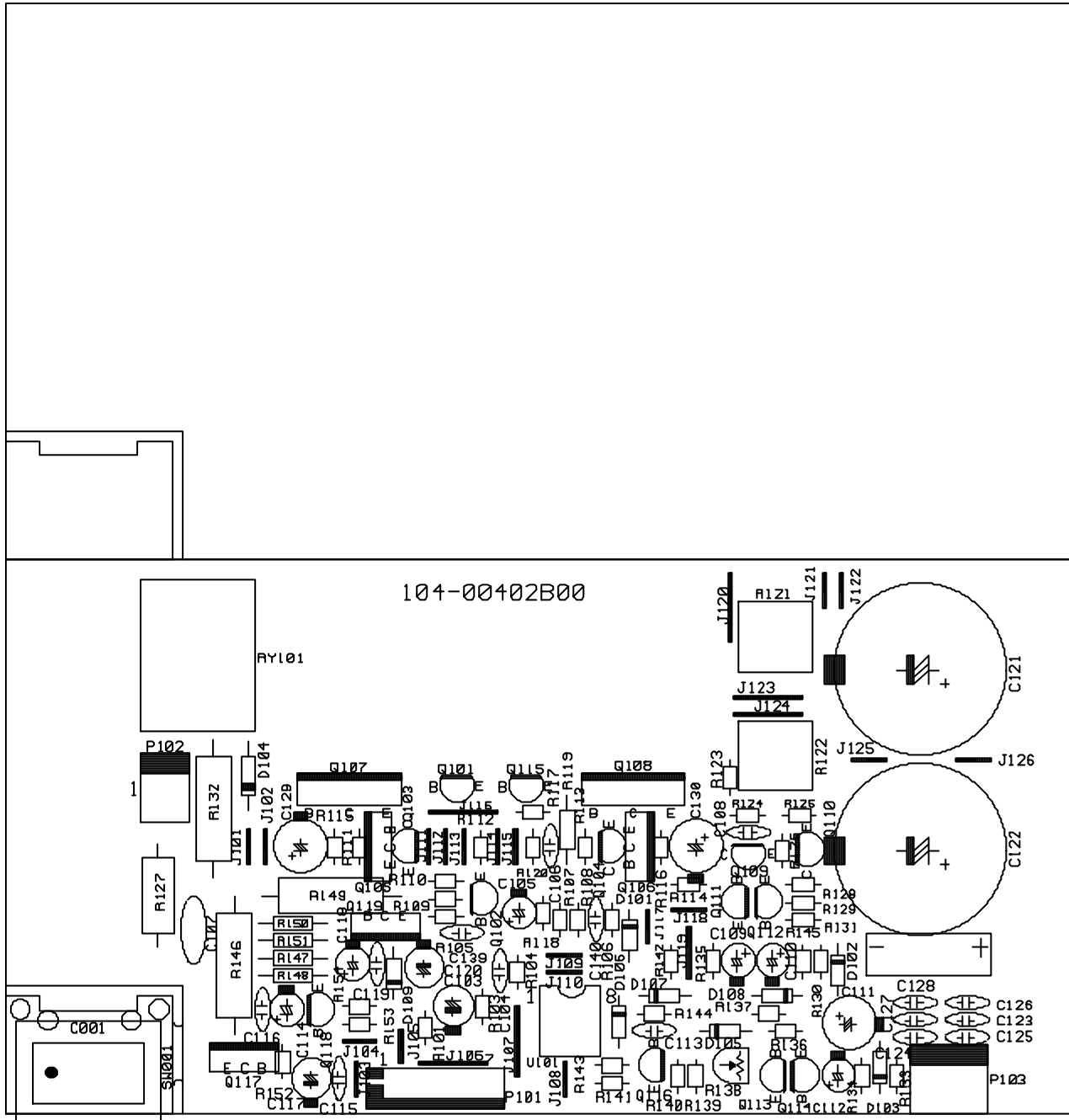

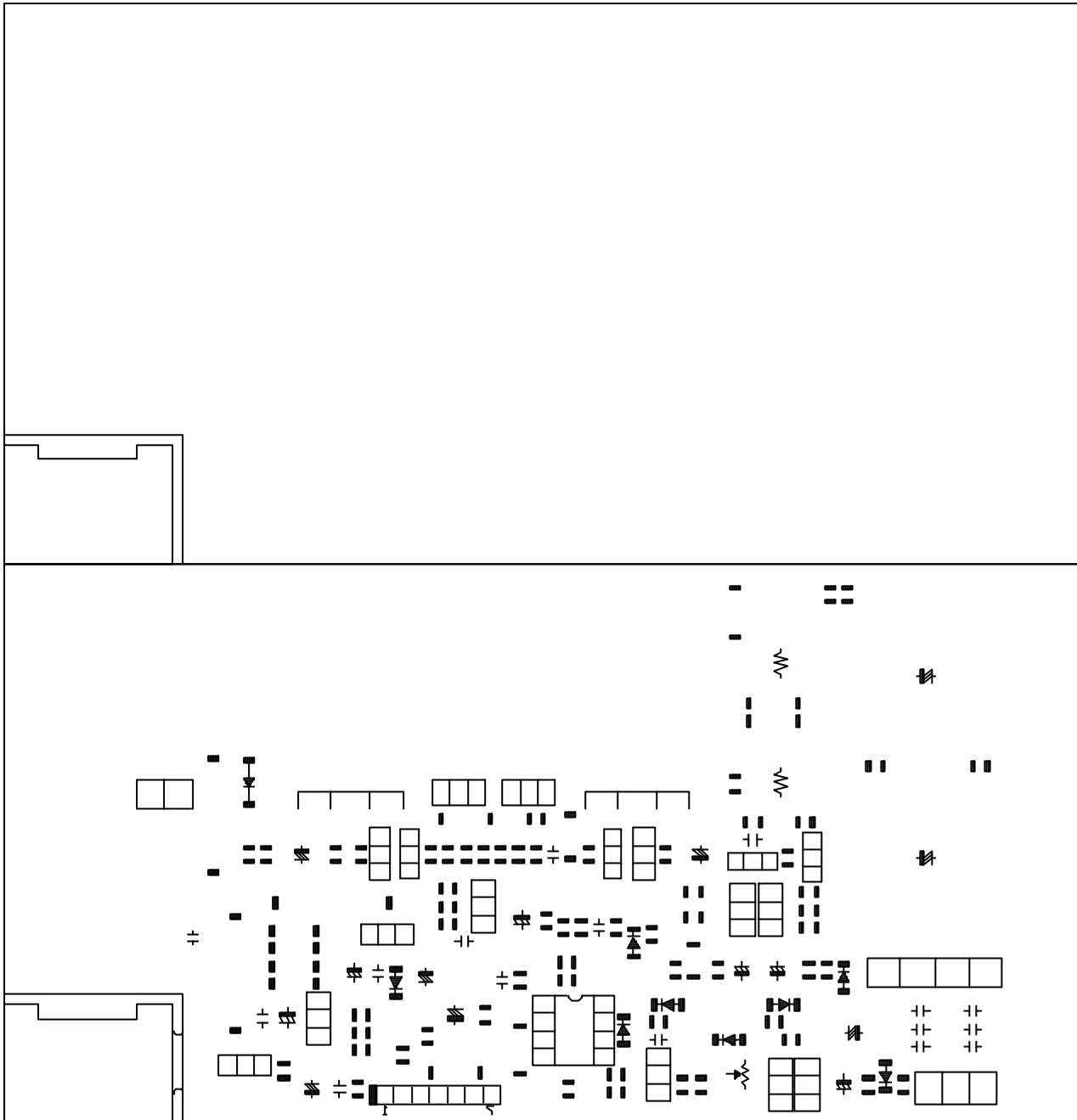

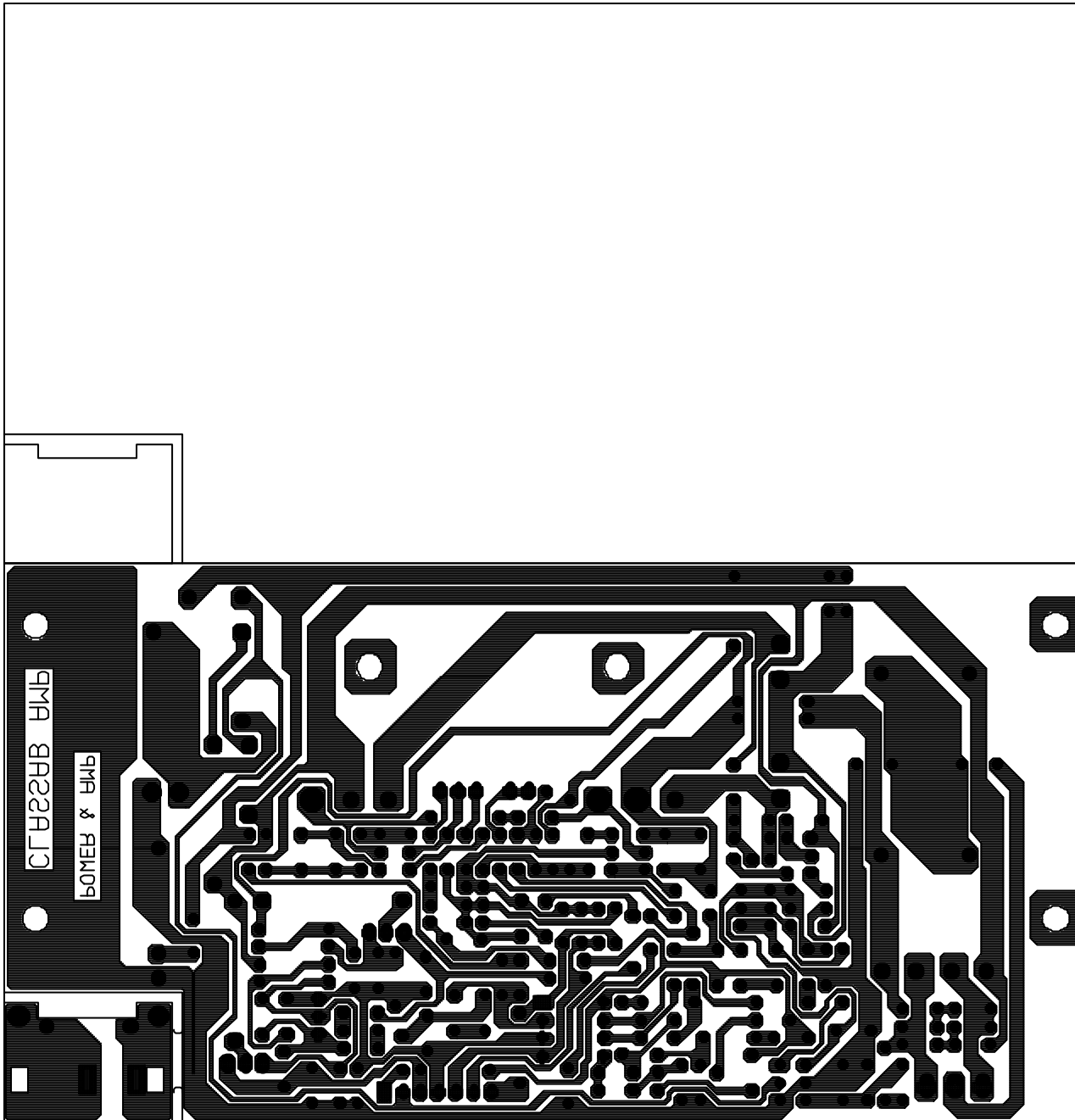

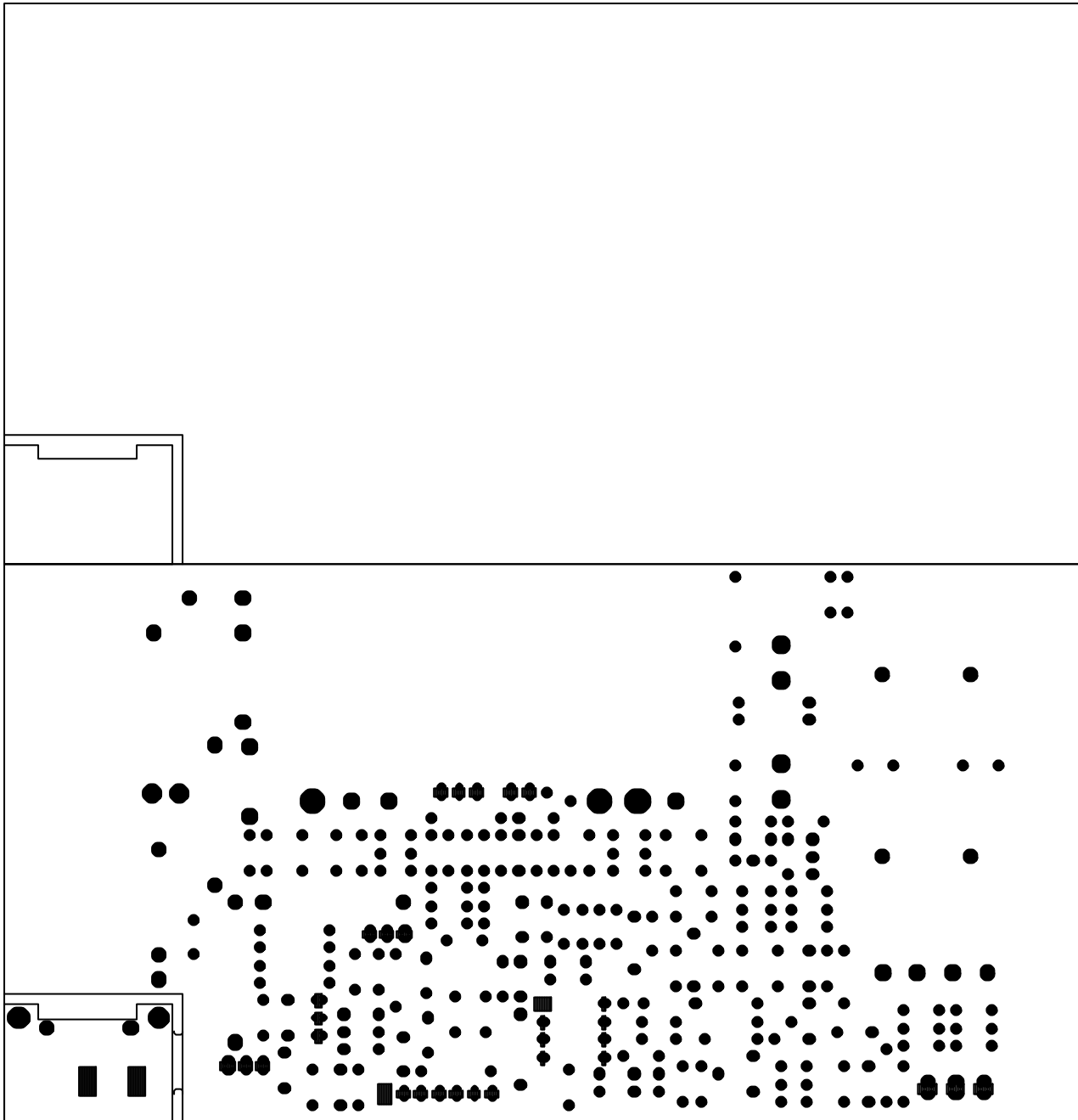

TSS-Sub500 (120v) Electrical Parts List			
Part Number	Description	Qty	Reference Designator
PREAMP PCB			
<i>Resistors</i>			
110-16102j26	Resistor 1K 1/6W ±5% CF 26mm	4	R213,214,215,254
110-16103j26	Resistor 10K 1/6W ±5% CF 26mm	13	R212,216,217,220,221,222,225,228,226,232,235,240,248
110-16104j26	Resistor 100K 1/6W ±5% CF 26mm	2	R231,266
110-16105j26	Resistor 1M 1/6W ±5% CF 26mm	1	R259
110-16122j26	Resistor 1.2K 1/6W ±5% CF 26mm	1	R264
110-16124j26	Resistor 120K 1/6W ±5% CF 26mm	1	R233
110-16151j26	Resistor 150Ω 1/6W ±5% CF 26mm	1	R253
110-16153j26	Resistor 15K 1/6W ±5% CF 26mm	1	R234
110-16154j26	Resistor 150K 1/6W ±5% CF 26mm	1	R252
110-16183j26	Resistor 18K 1/6W ±5% CF 26mm	2	R262,227
110-16205j26	Resistor 2M 1/6W ±5% CF 26mm	1	R257
110-16223j26	Resistor 22K 1/6W ±5% CF 26mm	4	R238,247,250,255
110-16273j26	Resistor 27K 1/6W ±5% CF 26mm	2	R223,237
110-16333j26	Resistor 33K 1/6W ±5% CF 26mm	1	R249
110-16472j26	Resistor 4.7K 1/6W ±5% CF 26mm	2	R258,260
110-16473j26	Resistor 47K 1/6W ±5% CF 26mm	2	R219,251
110-16512j26	Resistor 5.1K 1/6W ±5% CF 26mm	3	R211,229,230
110-16513j26	Resistor 51K 1/6W ±5% CF 26mm	1	R224
115-h503a104	variable Resistor D16 50K/1 A LEVEL	1	VR201
<i>Capacitors</i>			
130-2b221k503	disc Capacitor 220P 50V ± 10%	9	C207,208,210,211,212,214,220,230,249
130-3f104z503	disc Capacitor 0.1U 50V +80/-20%	7	C232,242,244,245,246,252,254
130-sl470k503	disc Capacitor 47P 50V ± 10%	1	C229
132-103j503	electrolytic 0.01U 50V ± 5%	2	C223,224
132-104j503	electrolytic 0.1U 50V ± 5%	3	C218,221,222
132-223ja03	electrolytic 0.22uF 100V ± 5%	1	C215
132-473j503	electrolytic 0.047U 50V ± 5%	2	C216,217
135-3105m50	electrolytic 1U 50V ± 20%	1	C228
135-3106m50	electrolytic 10uF 50V ± 20%	8	C206,213,219,231,241,243,251,253
135-3107m16	electrolytic 100uF 16V ± 20%	2	C233,234
135-3226m50	electrolytic 22U 50V ± 20%	1	C225
<i>Semiconductors</i>			
192-027c1815gr	Transistor 2SC1815GR NPN	3	Q201,206,207
197-031n4148	diode 100mA 75V SIGNAL 1N4148 ROHM	7	D201,202,207,208,211,212,214
199-15000335	zener diode 3.3V 1/2W 52mm	1	D213
190-06m4558d	I.C OPA 4558D DUAL OP-AMP	1	U203
190-16t1074cn	I .C TL074cm QUAD OP-AMP	2	U201,202
195-10204hgw	LED 204HGW 3c	1	D209
<i>Miscellaneous</i>			
162-50159201	WIRE ASS'Y 2PIN 150mm	1	for D209
174-0rca326p	JACK RCA-326	1	JK202
POWER/MAIN PCB			
<i>Resistors</i>			
110-14472j26	Resistor 4.7K 1/4W ±5% 26mm	2	R147,150
110-14681j26	Resistor 680Ω 1/4W ±5% 26mm	2	R148,151

Part Number	Description	Qty	Reference Designator
POWER/MAIN PCB			
110-16101j26	Resistor 10 0Ω 1/6W ±5% CF 26mm	1	R120
110-16102j26	Resistor 1K 1/6W ±5% CF 26mm	1	R124
110-16103j26	Resistor 10K 1/6W ±5% CF 26mm	1	R134
110-16105j26	Resistor 1M 1/6W ±5% CF 26mm	1	R143
110-16123j26	Resistor 12K 1/6W ±5% CF 26mm	2	R135,139
110-16152j26	Resistor 1.5K 1/6W ±5% CF 26mm CF	6	R103,123,136,137,141,142
110-16153j26	Resistor 15K 1/6W ±5% CF 26mm	4	R118,145,152,154
110-16154j26	Resistor 150K 1/6W ±5% CF 26mm	1	R131
110-16181j26	Resistor 18Ω 1/6W ±5% CF 26mm	2	R111,114
110-16182j26	Resistor 1.8K 1/6W ±5% CF 26mm	1	R153
110-16223j26	Resistor 22K 1/6W ±5% CF 26mm	3	R128,129,133
110-16332j26	Resistor 3.3K 1/6W ±5% CF 26mm	3	R106,107,144
110-16392j26	Resistor 3.9K 1/6W ±5% CF 26mm	2	R105,108
110-16393j26	Resistor 39K 1/6W ±5% CF 26mm	1	R126
110-16470j26	Resistor 47Ω 1/6W ±5% CF 26mm	4	R112,113,115,116
110-16471j26	Resistor 470Ω 1/6W ±5% CF 26mm	1	R140
110-16472j26	Resistor 4.7K 1/6W ±5% CF 26mm	3	R110,125,130
110-16473j26	Resistor 47K 1/6W ±5% CF 26mm	1	R101
110-16560j26	Resistor 56Ω 1/6W ±5% CF 26mm	1	R117
110-16563j26	Resistor 56K 1/6W ±5% CF 26mm	1	R104
110-16682j26	Resistor 6.8K 1/6W ±5% CF 26mm	1	R109
110-10821jk2	Resistor 820Ω 1W ±5% 10mm	1	R132
110-122r2j15	Resistor 2.2Ω 1/2W ±5% 15mm	1	R127
110-20331jk2	Resistor 330Ω 2W ±5% 5mm	2	R146,149
113-50r10j10	cement Resistor 0.1Ω 5W ±5%	2	R121,122
114-03302m0	semi-fixed Resistor 3K 0.3W 1±20%	1	R138
Capacitors			
130-2b102k503	disc Capacitor 1000p 50V±10%	1	C116
130-2f104z503	disc Capacitor 0.1u 50V+80/-20%	4	C108,113,115,119
130-3f473m503	disc Capacitor 0.047u 50V±20%	1	C106
130-s1101k503	disc Capacitor 100p 50V SL±10%	2	C139,140
132-104j503	mylar Capacitor 0.1u 50V ±5%	1	C107
132-223ja03	mylar Capacitor 0.022uF 100V ±5%	4	C124,125,126,128
135-3105m50	mylar Capacitor 1U 50V ±20%	2	C105,112
135-3107m16	mylar Capacitor 100uF 16V ±20%	3	C109,117,120
135-3226m50	mylar Capacitor 22U 50V ±20%	2	C114,118
135-3227m10	mylar Capacitor 220U 10V ±20%	2	C129,130
135-3227m16	mylar Capacitor 220U 16V ±20%	1	C111
135-3476m25	mylar Capacitor 47U 25V ±20%	1	C103
132-223ja03	mylar Capacitor 0.022uF 100V ±5%	2	C123,127
135-3107m16	electrolytic 100uF 16V ±20%	1	C110
135-4688m50	electrolytic 6800U/50V ±20% D25X45mm	2	C121,122
Semiconductors			
192-027c1815gr	Transistor 2SA1815GR NPN	5	Q102,111,112,113,118
192-028a1015gr	Transistor 2SA1015GR PNP	2	Q114,116
192-1572n5551	Transistor 2N5551 NPN	2	Q103,109
192-1582n5401	Transistor 2N5401 AI-PNP 350V 500MA TO-92	2	Q104,110
197-031n4148	diode 100mA 75V SIGNAL 1N4148 ROHM	4	D101,103,105,108
199-15000335	zener diode 3.3V 1/2W 52mm	1	D102
199-15000625	zener diode 6.2V 1/2W 52mm	2	D106,107
199-15001605	zener diode 16V 1/2W 52mm	1	D109
190-06m4558d	IC OPA 4558D DUAL OP-AMP	1	U101
192-021tip35c	Transistor TIP35C NPN	1	Q107
192-022tip36c	Transistor TIP36C PNP	1	Q108
192-027c1815gr	Transistor 2SC1815GR NPN	2	Q101,115
192-201d882Y	Transistor KSD882Y PNP	1	Q117

Part Number	Description	Qty	Reference Designator
POWER/MAIN PCB			
192-202b772y	TransistorKSD772Y PNP	1	Q119
192-991d669a	TransistorHI-SINCERITY HSD669A NPN	1	Q106
192-992b649t	Transistor HSB649T PNP	1	Q105
197-00kb1405	diode 4A500V KBL405 BRIDGE	1	D110
197-101n4002	diode IN4002	1	D104
<i>Miscellaneous</i>			
162-10202001	wire 26AWC 1007 200mm RED	1	
171-udhss124d	relay 5A 24V UDH-SS124D	1	RY101
175-1c07v01	wire connector 7PIN PITCH=2.5mm	1	P101
175-1d02v01	wire connector 2PIN PITCH=3.96mm	1	P102
175-1d03v01	wire connector 3PIN PITCH=3.96mm	1	P103
193-3m2520	insulator TO-3P 25x20mm	2	for Q107,108
LIMITER PCB			
110-16103j26	Resistor 10K 1/6W ±5% CF 26mm	8	R301,303,304,308,309,314,340,344
110-16183j26	Resistor 18K 1/6W ±5% CF 26mm	1	R302
110-16223j26	Resistor 22K 1/6W ±5% CF 26mm	2	R310,312
110-16273j26	Resistor 27K 1/6W ±5% CF 26mm	1	R341
110-16333j26	Resistor 33K 1/6W ±5% CF 26mm	1	R305
110-16472j26	Resistor 4.7K 1/6W ±5% CF 26mm	2	R342,343
110-16474j26	Resistor 470K 1/6W ±5% CF 26mm	1	R307
110-16751j26	Resistor 750Ω 1/6W ±5% CF 26mm	2	R311,313
110-16755j26	Resistor 7.5k 1/6W ±5% CF 26mm	1	R306
130-2f104z503	disc Capacitor 0.1u 50V +80/-20%	2	C305,306
132-103j503	mylar Capacitor 0.01U 50V ± 5%	2	C302,303
135-3226m50	electrolytic 22U 50V ± 20%	2	C301,340
135-3476m25	electrolytic 47U 25V ± 20%	1	C304
192-027c1815gr	Transistor 2SC1815gr NPN	2	Q301,302
197-031n4148	diode 100mA 75V SIGNAL 1N4148	2	D301,302
162-50289001	CABLE ASS'Y wire's 280mm AWG26 WHT	1	
175-9f40hr2	coupling 40PIN PITCH=2.54mm HR2*40	0.15	P301
190-16tl074cn	I.C TL074cm st QUAD OP-AMP	1	U301
MISCELLANEOUS/MECHANICAL			
123-14j70d	Ferrite Core U-16.3*8.2*13(J70)+CASE	1	
130-3f472md00	disc Capacitor 4700P 400V ± 20%	1	C001
150-e8604107	Power Transformer EI-86 60HZ 120V TT086996580	1	T1
152-u602015	LineCord SVT FT-2 6FT	1	
154-u25006t0	Fuse 2.5A 250V 20mm	1	
155-520020	Fuse Holder R3-11	1	
162-10082007	WIRE RED 18AWG 80mm 8mm#1015	1	
162-50652003	WIRE 650mm RED=205# 0.5T BLK=110# 0.5T	1	
176-wjcel	wire connector Pin CE-1	1	
180-prf1003S	switch ROCK RF-1003-BB2-OHA POWER	1	SW100
176-wjce1	wire connector pin CE-1	1	
350-EM04012D024	4 ∅*12 wood screw black	4	
351-HM04016A218	M4*16 machine screw black	4	
351-AM03008A079	M3*8 machine screw black	6	
352-AM03010D065	∅3*10 P type tapping screw black	2	
352-AM03008D040	∅3*8 B type tapping screw black	8	
354-GM04002	M4 nut black	4	
362-FE-00013	PCB support L TYPE t=1.6mmS.P.C.C 89*9*1.6T	2	
311-ABS-00028	plastic knob 46077-W soft matetial P.V.C. LEVEL	1	
335-NYL-00002	wire clip 4K-4 NO-BB	2	

Part Number	Description	Qty	Reference Designator
MISCELLANEOUS/MECHANICAL			
333-EVA-00783	EVA W 198*12*2.0T	2	
333-EVA-00807	EVA L 274*12*2.0T	2	
333-EVA-00826	EVA W 198*12*1.0T	2	
333-EVA-00835	EVA L 274*12*1.0T	2	
320-RUB-00033	rubber foot pad 25*21*4t	4	
337-CU-00101	copper foil 65L*50W	1	
306-ABS-00177	rear Plastic housing 198*298*102mm	1	
162-50552003	WIRE UL1007 #16 550mm#110/#205 0.5T	1	
302-AL-05048-0BAE	rear board 300*200*2.5T black(RoHS)	1	
323-AL-00106-0BB	HEAT SINK 117.5*71.5*25 anode is black	1	

Integrated Circuit Diagrams

4558 Dual Op Amp
U101,203

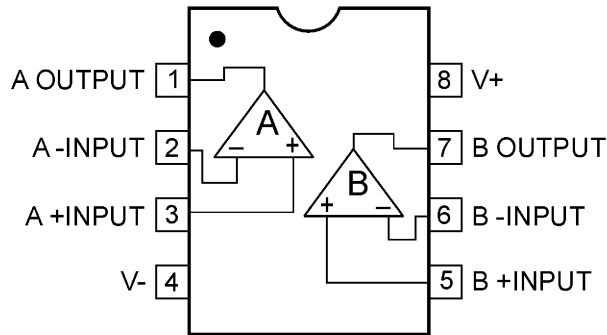

OPAMP, QUAD 14P DIL TL074
U201, 202, 301

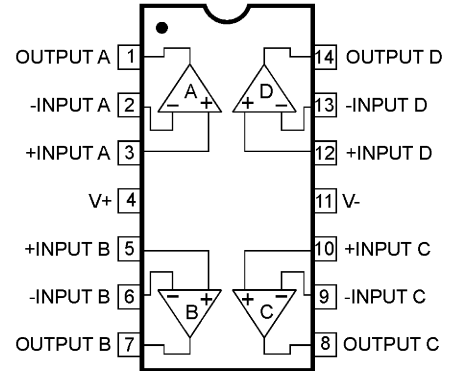

TIP35C, TIP36C
Q107,108

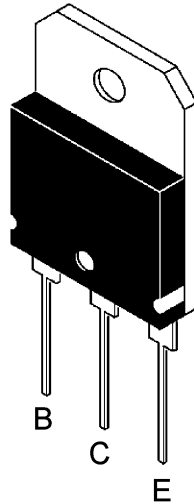

2N5401
Q104, 110

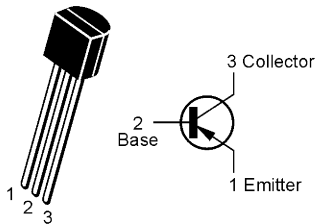

2N5551
Q103, 109

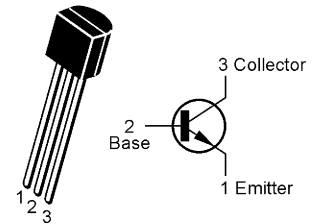

2SD669A, 2SB649A
KSB772, KSD882
Q105, 106, 117, 119



1. Emitter
2. Collector
3. Base

2SA1015
Q114, 116

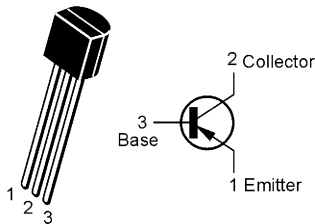

2SC1815
Q101, 102, 111, 112, 113, 115, 118,
201, 206, 207, 301, 302.

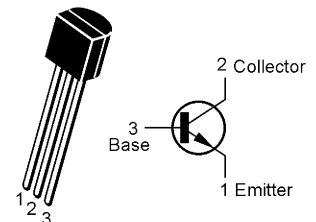

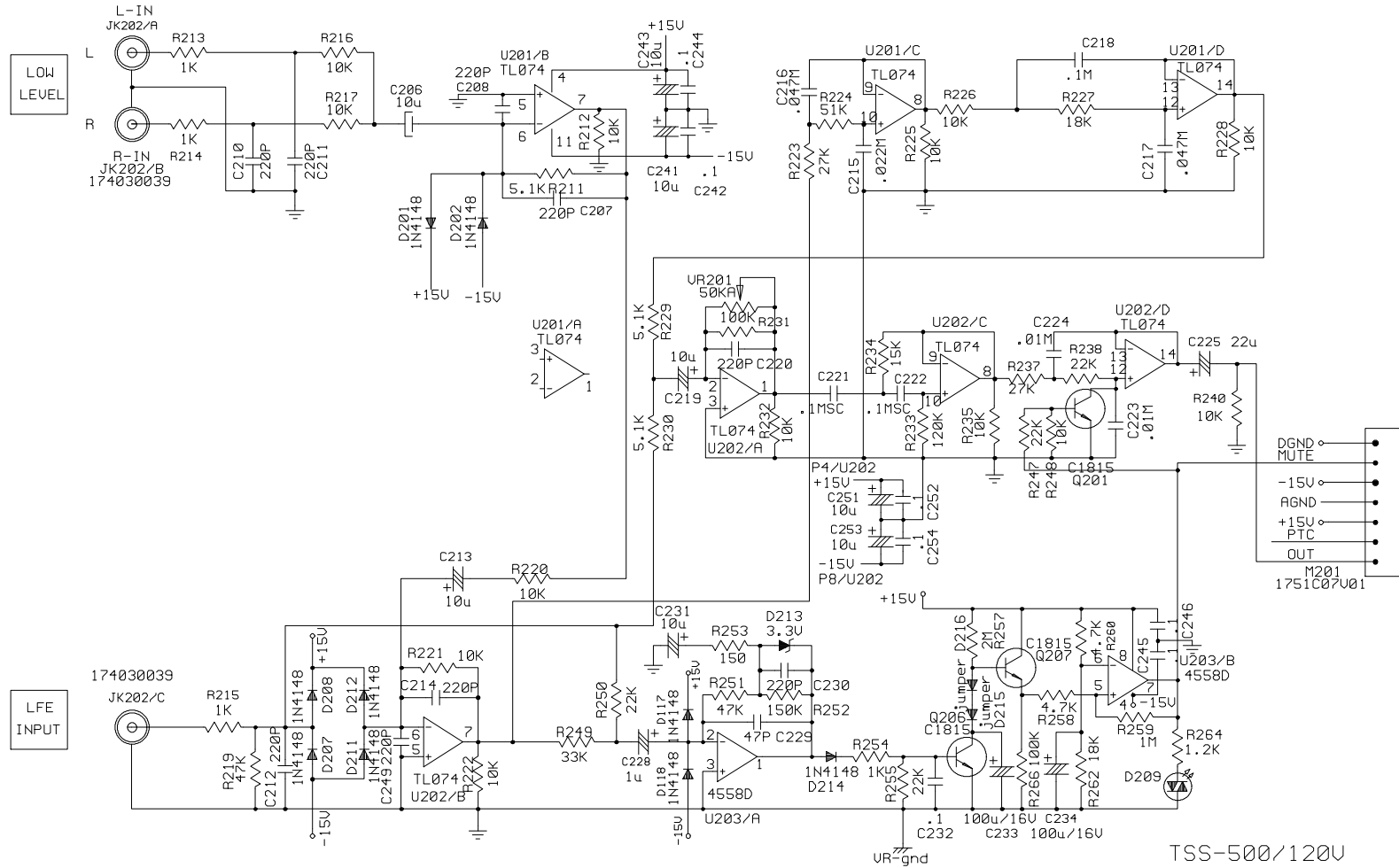

TSS-500/120U

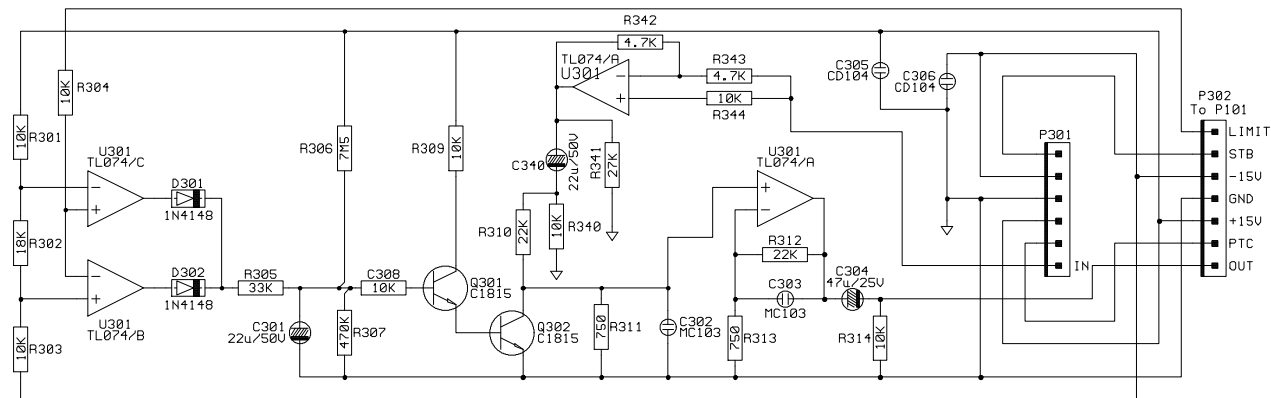

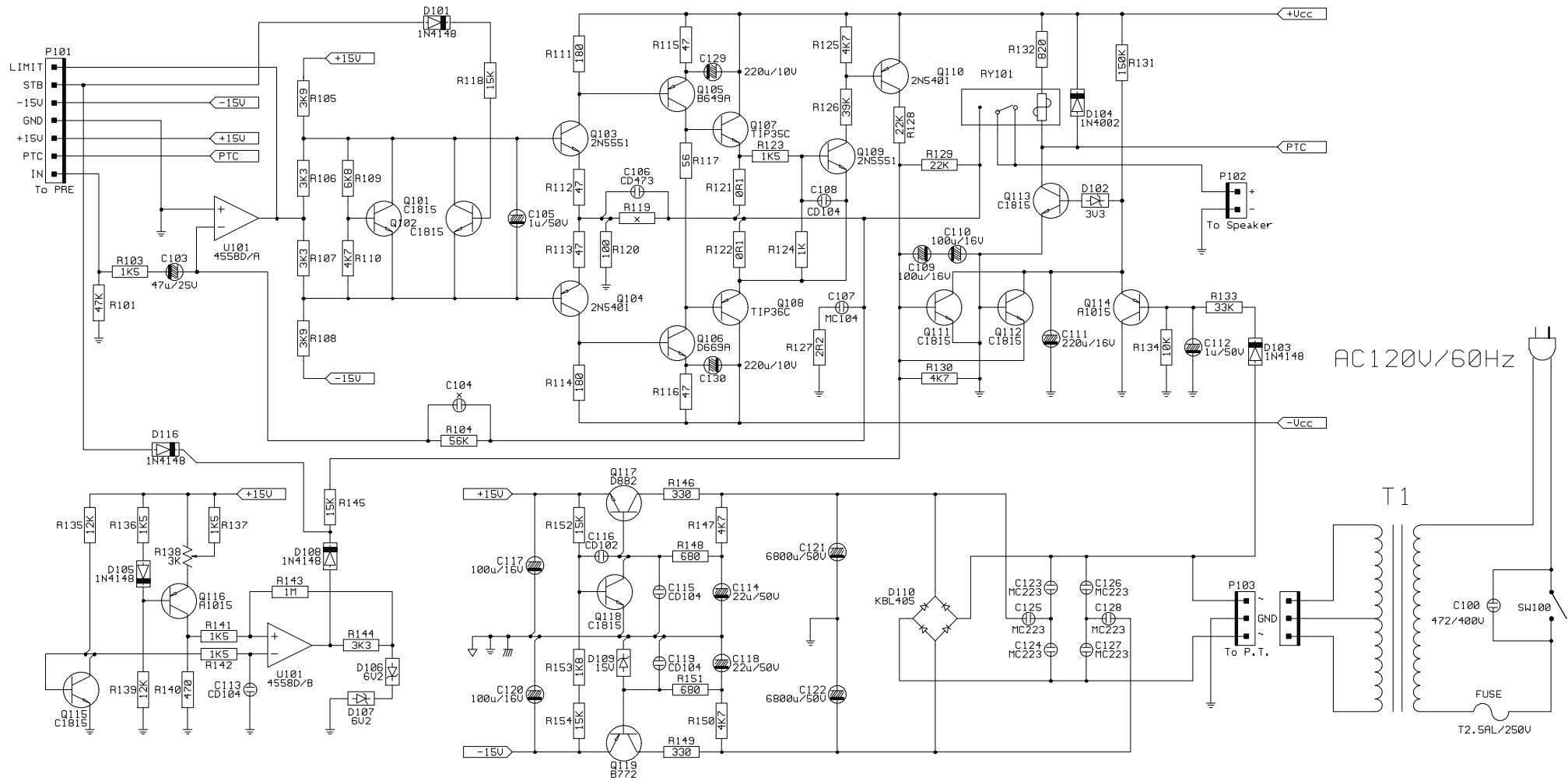

Temperature protect voltage set:
Adj.UR138,changed the voltage of
R140 to 510+/-2mVdc

DRAW.	DSGN.	APVD.	FILENAME :TSS-500/120V	REVISION :
			MODEL NO.	1
			DWN BY :Q.H.PENG	2
			DATE :2005.03.09	3