



# PS-10

# PS-12

## PS Series Powered Subwoofers

# SERVICE MANUAL



Infinity Systems Incorporated  
250 Crossways Park Dr.  
Woodbury, New York 11797

Rev1 10/2004

# CONTENTS

BASIC SPECIFICATIONS . . . . . 1

PS-10 DETAILED SPECIFICATIONS . . . . . 2

PS-12 DETAILED SPECIFICATIONS . . . . . 4

CONTROLS & CONNECTIONS . . . . . 6

OPERATION..... 8

PS-10 BLOCK DIAGRAM..... 9

PS-12 BLOCK DIAGRAM..... 10

PS-10/12 TEST SET-UP AND PROCEDURE.....11

TECH TIP INFTT2003-02..... 12

PS-10 EXPLODED VIEW . . . . . 13

PS-12 EXPLODED VIEW . . . . . 14

PS-10 PACKING.....15

PS-12 PACKING.....16

PS-10 ELECTRICAL PARTS LIST . . . . . 17

PS-12 ELECTRICAL PARTS LIST . . . . . 21

PCB DRAWINGS. . . . . 25

IC – TRANSISTOR PINOUTS . . . . . 28

PS-10 SCHEMATIC DIAGRAMS . . . . . 29

PS-12 SCHEMATIC DIAGRAMS . . . . . 31

## SPECIFICATIONS

### PS-10

### PS-12

Frequency Response:	27Hz – 150Hz (±3dB)	25Hz – 150Hz (±3dB)
Maximum Amplifier Output: (20Hz – 150Hz with no more than 0.1% THD)	250 watts RMS	300 watts RMS
Crossover Frequencies: 24dB/octave, continuously variable	50Hz – 150Hz,	50Hz – 150Hz
Driver:	10" (254mm) MMD™	12" (305mm) MMD™
Dimensions (H x W x D):	14 3/4" x 12-1/2" x 16" (375mm x 318mm x 406mm)	16-1/2" x 14-3/8" x 17-1/2" (419mm x 365mm x 445mm)
Weight:	38 lb (17.3kg)	45 lb (20.5kg)

Infinity continually strives to update and improve existing products, as well as create new ones. The specifications and construction details in this and related Infinity publications are therefore subject to change without notice.

PS-10 Powered Sub/ Plate Amp					
LINE VOLTAGE	Yes/No	Hi/Lo Line	Nom.	Unit	Notes
US 120vac/60Hz	Yes	108-132	120	Vrms	Normal Operation
EU 230vac/50-60Hz	Yes	207-264	230	Vrms	Normal operation, MOMS required
Parameter	Specification	Unit	QA Test Limits	Conditions	Notes
<b>Amp Section</b>					
Type (Class AB, D, other)	D	n/a	n/a		
Load Impedance (speaker)	5.6	Ohms	n/a	Nominal	
Rated Output Power (120VAC)	150	Watts	138		Domestic version only 120 VAC-60 Hz
Rated Output Power (230VAC)	150	Watts	128		EU Version only 230 VAC-50 Hz
AVG RMS Dynamic Power	250	Watts	225		Average RMS power, 3/20 Cycles 50 Hz, Driven 6dB above its input sensitivity sensitivity
THD @ Rated Power	0.5	%	1	22K filter	145 Watts
THD @ 1 Watt	0.1	%	0.5	22K filter	
DC Offset	10	mV-DC	30	Amplifier output	
Damping factor	>50	DF	20	Measured at amplifier board	Measured at the amplifier board. 150 Watts @ 50 Hz, THD must be less than 0.1%
<b>Input Sensitivity</b>					
Input Frequency	35	Hz	35	Nominal Freq.	
L&R	300	mVrms	±2dB	To 150 Watts, Ap Zo=600 Ohms	Single input driven
L or R input	300	mVrms	±2dB	To 150 Watts, Ap Zo=600 Ohms	Single input driven, LFE switch ON
Speaker/Hi Level Input	2.6	Vrms	±2dB	To 150 Watts	Single input driven
<b>Signal to Noise</b>					
SNR-A-Weighted	90	dBA	85	relative to rated power	A-Weighting filter
SNR-unweighted	85	dBr	75	relative to rated power	22K filter
SNR rel. 1W-unweighted	65	dBr	60	relative to 1W Output	22K filter
Residual Noise Floor	1	mVrms	1.5	Volume @max, using RMS reading DMM/VOM (or A/P) BW=20 Khz.	Line level inputs must be terminated using 1KOHM
Residual Noise Floor	1.5	mVrms(max)	1.5	Volume @max, w/ A/P Swept Bandpass Measurement (Line freq.+ harmonics) (BW=20 Khz)	Line level inputs must be terminated using 1KOHM
<b>Input Impedance</b>					
Line Input (L, R,LFE)	10K	ohms	n/a	Nominal	
Speaker/Hi Level Input	> 4.7K	ohms	n/a	Nominal	
<b>Filters</b>					
LP filter 4th order fixed	50-150	Hz	± 10	2nd Order variable and 2nd order fix	2nd order variable + 2nd order fix-24 db/Octave
HP Filter 2nd order	Fixed			F=32 Hz, Q=0.95	
LFE Low pass 2nd order	200>LP<1K	Hz		LFE input driven only	
Notch filter (Friend circuit)				F=61.6 Hz, Q=4, Av=-3.5dB	
HP speaker out connector					
Left & Right	200	Hz	± 10	Speaker input driven - 4 Ohms	(Applies to 230VAC model only)
Left & Right	100	Hz	± 10	Speaker input driven - 8 Ohms	(Applies to 230VAC model only)
<b>Limiter</b>					
THD at Max. Output Power	n/a	n/a	functional	Maximum Output Power	Maximum THD as a result of limiting.
<b>Features</b>					
Volume pot Taper (lin/log)	LOG	--	functional		A Taper
Speaker input connectors	YES		functional		L&R Speaker input binding post connectors
HP Speaker out	YES		functional		L&R Speaker out with HP applies only to 230VAC models
Phase switch	0-180	deg	functional		
LP Filter defeat switch	YES		functional		Disables LP filter, intended for LFE
<b>Input Configuration</b>					
Line In (L,R) & LFE	YES	--	functional		Dual RCA jack
Spkr/Hi Level In	YES	--	functional		Binding post connector L&R
<b>Signal Sensing (ATO)</b>					
Auto-Turn-On (yes/no)	YES		functional		
ATO Input test frequency	50	Hz	functional	"	
ATO Level LFE Input	2	mV	functional	"	Maximum acceptable level.
ATO Level Speaker in	40	mV	functional	"	Maximum acceptable level.
ATO Turn-on time	5	ms	functional	Amp connected and AC on, then input signal applied	
Auto Mute/ Turn-OFF Time	15	minutes	18	T before muting, after line or speaker level signal is removed	Auto turn of time (T) must be 5 > T < 18 Minutes
<b>Power on Delay time</b>					
	3	sec.	4	AC Power Applied	
<b>Transients/Pops</b>					
ATO Transient	5	mV-peak	n/a	@ Speaker Outputs	

Turn-on Transient	50	mV-peak	2V-pk-pk	@ Speaker Outputs	AC Line cycled from OFF to ON
Turn-off Transient	50	mV-peak	2V-pk-pk	@ Speaker Outputs	AC Line cycled from ON to OFF
<b>Efficiency</b>					
Efficiency	65	%	65		Nominal Line voltage 120 VAC
Stand-by Input Power	18	Watts	20	@ nom. line voltage	Maximum allowable input power under nominal Input voltage and frequency, HOT or COLD operation.
Power Cons. @ rated power	230	Watts	240	@ nom. line voltage	150 Watts into 5.6 Ohms @ nominal line voltage
<b>Protections</b>					
Short Circuit Protection	YES		functional	Direct short at output	Amplifier should resume operation after short circuit condition removal
Thermal Protection	YES		functional	@ 1/8 max unclipped Power at 1.06 times the input voltage	Temperature rise in accessible metal parts should not exceed 35K rise for domestic version or 30K rise for European versions (refer to requirements sheet).
DC Offset Protection	YES		-	DC present at Speaker Out leads	Design must insure no Offset at the speaker output under any operating condition including abnormal operation
Line Fuse Rating					
USA-Domestic	2	Amps	2	Type-T or Slo Blo-250 V	Internal fuse with UL/SEMKO rated holder
EU (230v)	1.25	Amps	1.25	Type-T or Slo Blo-250 V, Low Breaking capacity	Internal fuse with UL/SEMKO rated holder
4. ALL SPECS SHOULD BE MEASURED AT NOMINAL LINE VOLTAGE.					
5.- EUROPEAN VERSION MUST BE PROVIDED WITH PLASTIC PLUGS ON THE BINDING POST CONNECTORS					

PS-12 Powered Sub/ Plate Amp					
LINE VOLTAGE	Yes/No	Hi/Lo Line	Nom.	Unit	Notes
US 120vac/60Hz	Yes	108-132	120	Vrms	Normal Operation
EU 230vac/50-60Hz	Yes	207-264	230	Vrms	Normal operation, MOMS required
Parameter	Specification	Unit	QA Test Limits	Conditions	Notes
<b>Amp Section</b>					
Type (Class AB, D, other)	D	n/a	n/a		
Load Impedance (speaker)	5.6	Ohms	n/a	Nominal	
Rated Output Power (120VAC)	150	Watts	138		Domestic version only 120 VAC-60 Hz
Rated Output Power (230VAC)	150	Watts	128		EU Version only 230 VAC-50 Hz
AVG RMS Dynamic Power	250	Watts	225		Average RMS power, 3/20 Cycles 50 Hz, Driven 6dB above its input sensitivity sensitivity
THD @ Rated Power	0.5	%	1	22K filter	140 Watts
THD @ 1 Watt	0.1	%	0.5	22K filter	
DC Offset	10	mV-DC	30	Amplifier output	
Damping factor	>50	DF	20	Measured at amplifier board	Measured at the amplifier board. 140 Watts @ 50 Hz, THD must be less than 0.1%
<b>Input Sensitivity</b>					
Input Frequency	35	Hz	35	Nominal Freq.	
L&R	250	mVrms	±2dB	To 150 Watts, Ap Zo=600 Ohms	Single input driven
L or R input	250	mVrms	±2dB	To 150 Watts, Ap Zo=600 Ohms	Single input driven, LFE switch ON
Speaker/Hi Level Input	2.3	Vrms	±2dB	To 150 Watts	Single input driven
<b>Signal to Noise</b>					
SNR-A-Weighted	90	dBA	85	relative to rated power	A-Weighting filter
SNR-unweighted	85	dBr	75	relative to rated power	22K filter
SNR rel. 1W-unweighted	65	dBr	60	relative to 1W Output	22K filter
Residual Noise Floor	1	mVrms	1.5	Volume @max, using RMS reading DMM/VOM (or A/P) BW=20 Khz.	Line level inputs must be terminated using 1KOHM
Residual Noise Floor	1.5	mVrms(max)	1.5	Volume @max, w/ A/P Swept Bandpass Measurement (Line freq.+ harmonics) (BW=20 Khz)	Line level inputs must be terminated using 1KOHM
<b>Input Impedance</b>					
Line Input (L, R,LFE)	10K	ohms	n/a	Nominal	
Speaker/Hi Level Input	> 4.7K	ohms	n/a	Nominal	
<b>Filters</b>					
LP filter 4th order fixed	50-150	Hz	± 10	2nd Order variable and 2nd order fix	2nd order variable + 2nd order fix-24 db/Octave
HP Filter 2nd order	Fixed			F=29 Hz, Q=1.5	
LFE Low pass 2nd order	200>LP<1K	Hz		LFE input driven only	
Notch filter (Friend circuit)				54 Hz, Q=1.738, Av=-5.0dB	
HP speaker out connector					
Left & Right	200	Hz	± 10	Speaker input driven - 4 Ohms	(Applies to 230VAC model only)
Left & Right	100	Hz	± 10	Speaker input driven - 8 Ohms	(Applies to 230VAC model only)
<b>Limiters</b>					
THD at Max. Output Power	n/a	n/a	functional	Maximum Output Power	Maximum THD as a result of limiting.
<b>Features</b>					
Volume pot Taper (lin/log)	LOG	--	functional		A Taper
Speaker input connectors	YES		functional		L & R Binding post connector
HP Speaker out	YES		functional		L & R Binding post connectors and High pass filter (Applies only to 230V model)
Phase switch	0-180	deg	functional		
LP Filter defeat switch	YES		functional		Disables LP filter, intended for LFE
<b>Input Configuration</b>					
Line In (L,R) & LFE	YES	--	functional		Dual RCA jack
Spkr/Hi Level In	YES	--	functional		Binding post connector L&R
<b>Signal Sensing (ATO)</b>					
Auto-Turn-On (yes/no)	YES		functional		
ATO Input test frequency	50	Hz	functional	"	
ATO Level LFE Input	2	mV	functional	"	Maximum acceptable level.
ATO Level Speaker in	40	mV	functional	"	Maximum acceptable level.
ATO Turn-on time	5	ms	functional	Amp connected and AC on, then input signal applied	
Auto Mute/ Turn-OFF Time	15	minutes	18	T before muting, after line or speaker level signal is removed	Auto turn of time (T) must be 5 > T < 18 Minutes
<b>Power on Delay time</b>					
	3	sec.	4	AC Power Applied	

Parameter	Specification	Unit	QA Test Limits	Conditions	Notes
<b>Transients/Pops</b>					
ATO Transient	5	mV-peak	n/a	@ Speaker Outputs	
Turn-on Transient	50	mV-peak	2V-pk-pk	@ Speaker Outputs	AC Line cycled from OFF to ON
Turn-off Transient	50	mV-peak	2V-pk-pk	@ Speaker Outputs	AC Line cycled from ON to OFF
<b>Efficiency</b>					
Efficiency	65	%	65		Nominal Line voltage 120 VAC
Stand-by Input Power	18	Watts	20	@ nom. line voltage	Maximum allowable input power under nominal input voltage and frequency, HOT or COLD operation.
Power Cons. @ rated power	230	Watts	240	@ nom. line voltage	150 Watts into 5.6 Ohms @ nominal line voltage
<b>Protections</b>					
Short Circuit Protection	YES		functional	Direct short at output	Amplifier should resume operation after short circuit condition removal
Thermal Protection	YES		functional	@1/8 max unclipped Power at 1.06 times the input voltage	Temperature rise in accessible metal parts should not exceed 35K rise for domestic version or 30K rise for European versions (refer to requirements sheet).
DC Offset Protection	YES		-	DC present at Speaker Out leads	Design must insure no Offset at the speaker output under any operating condition including abnormal operation
<b>Line Fuse Rating</b>					
USA-Domestic	2	Amps	2	Type-T or Slo Blo-250 V	Internal fuse with UL/SEMKO rated holder
EU (230v)	1.25	Amps	1.25	Type-T or Slo Blo-250 V, Low Breaking capacity	Internal fuse with UL/SEMKO rated holder
4. ALL SPECS SHOULD BE MEASURED AT NOMINAL LINE VOLTAGE.					
5.- EUROPEAN VERSION MUST BE PROVIDED WITH PLASTIC PLUGS ON THE BINDING POST CONNECTORS					

# CONTROLS AND CONNECTIONS

## Rear Panel

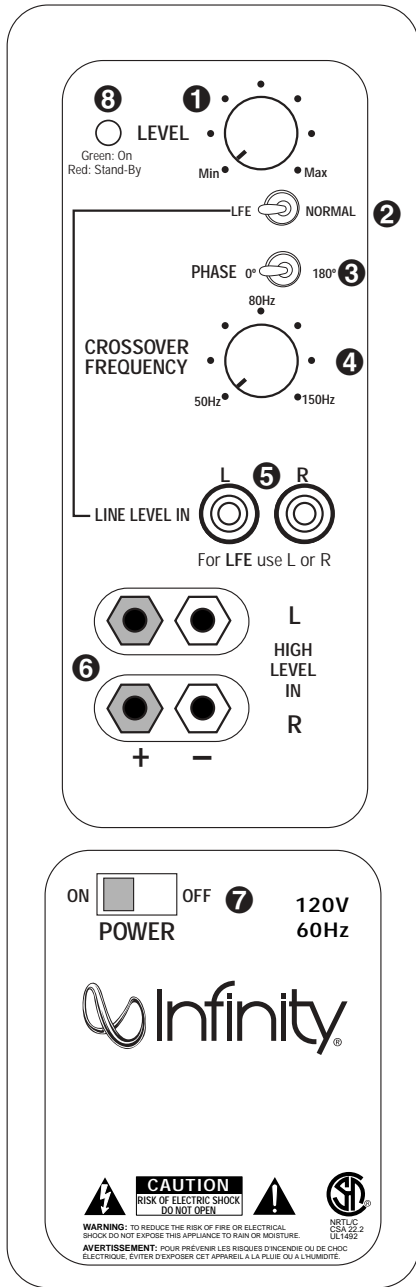

- 1 Subwoofer-Level Control
- 2 LFE/Normal Selector
- 3 Phase Switch
- 4 Crossover Adjustment
- 5 Line-Level/LFE Input
- 6 Speaker-Level Inputs
- 7 Power Switch
- 8 Status LED

# SYSTEM CONNECTIONS

If you have a Dolby® Digital or DTS® receiver/processor with a low-frequency-effects (LFE) or subwoofer output:

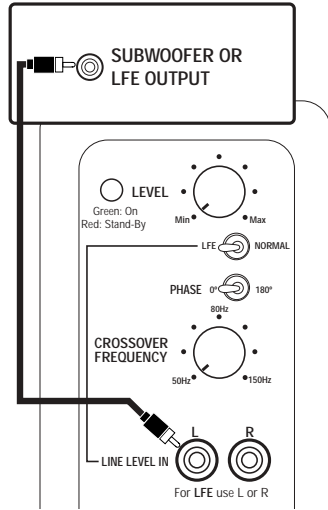

Set LFE/Normal switch to "LFE."

If your receiver/processor does not have subwoofer outputs for the left and right channels or an LFE output, connect speaker wire from your receiver/amplifier to your speakers and subwoofer using two sets of speaker wire:

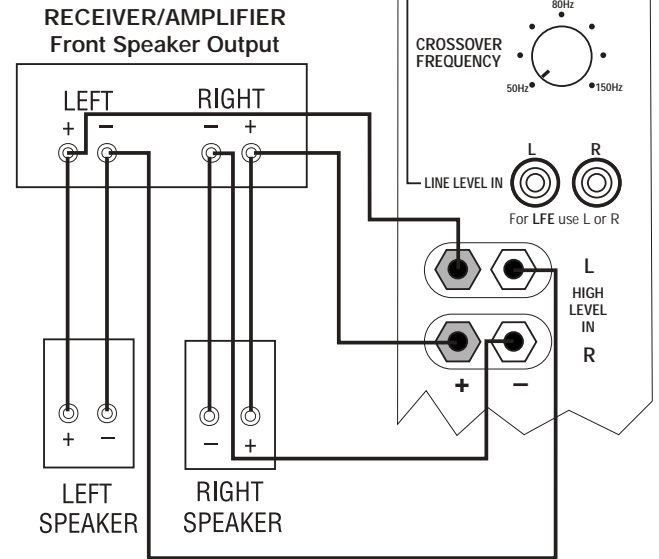

If your receiver/processor does not contain a Dolby Digital or DTS processor but has subwoofer outputs:

## RECEIVER/PROCESSOR

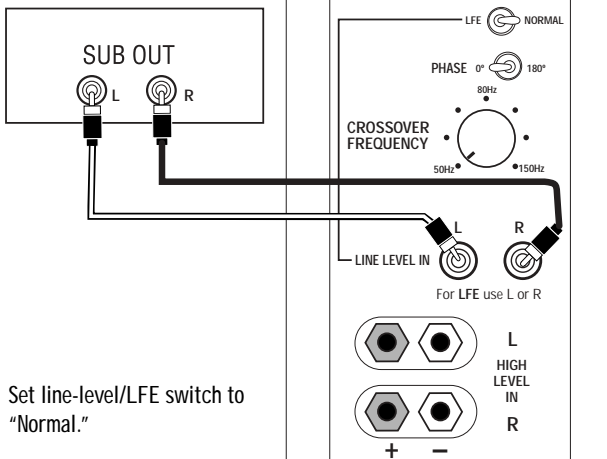

Set line-level/LFE switch to "Normal."

NOTE: If your receiver/processor has only one sub out, you may use either the L or R input.

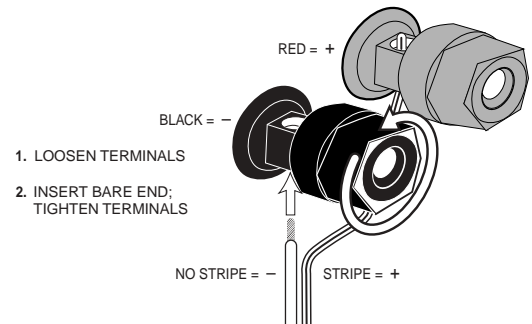

This figure shows how to connect bare wires to the terminals.



## OPERATION

### Power On

Plug your subwoofer's AC cord into a wall outlet. Do not use the outlets on the back of the receiver.

Initially set the Subwoofer-Level Control ❶ to the "min" position.

Turn on your sub by pressing the Power Switch ❷ on the rear panel.

Turn on your entire audio system and start a CD or movie soundtrack at a moderate level.

### Auto On/Stand-By

With the Power Switch ❷ in the ON position, the Status LED ❸ on the back panel will remain lit in red or green to indicate the On/Standby mode of the subwoofer.

RED = STANDBY (No signal detected, Amp Off)

GREEN = ON (Signal detected, Amp On)

The subwoofer will automatically enter the Standby mode after approximately 10 minutes when no signal is detected from your system. The subwoofer will then power ON instantly when a signal is detected. During periods of normal use, the Power Switch ❷ can be left on. You may turn off the Power Switch ❷ for extended periods of nonoperation, e.g., when you are away on vacation.

### Adjust Gain

Turn your Subwoofer-Level Control ❶ up to the halfway position. If no sound emanates from the subwoofer, check the AC-line cord and input cables. Are the connectors on the cables making proper contact? Is the AC plug connected to a "live" receptacle? Has the Power Switch ❷ been pressed to the "On" position? Once you have confirmed that the subwoofer is active, proceed by playing a CD, record or cassette. Use a selection that has ample bass information.

Set the overall volume control of the preamplifier or stereo to a comfortable level. Adjust the Subwoofer-Level Control ❶ until you obtain a pleasing blend of bass. Bass response should not overpower the room but rather be adjusted so there is a harmonious blend across the entire musical range. Many users have a tendency to set the subwoofer volume too loud, adhering to the belief that a subwoofer is there to produce lots of bass. This is not entirely true. A subwoofer is there to enhance bass, extending the response of the entire system so the bass can be felt as well as heard. However, overall balance must be maintained or the music will not sound natural. An experienced listener will set the volume of the subwoofer so its impact on bass response is always there but never obtrusive.

### Phase Control

The Phase Switch ❹ determines whether the subwoofer speaker's piston-like action moves in and out with the main speakers, 0°, or opposite the main speakers, 180°. Proper phase adjustment depends on several variables such as room size, subwoofer placement and listener position. Adjust the phase switch to maximize bass output at the listening position.

### Crossover Adjustment

The Crossover Adjustment Control ❺ determines the highest frequency at which the subwoofer reproduces sounds. If your main speakers can comfortably reproduce some low-frequency sounds, set this control to a lower frequency setting, between 50Hz and 100Hz. This will concentrate the subwoofer's efforts on the ultradeep bass sounds required by today's films and music. If you are using smaller bookshelf speakers that do not extend to the lower bass frequencies, set the Crossover Adjustment control to a higher setting, between 120Hz and 150Hz.

**NOTE:** This control will have no effect if the LFE/Normal Selector ❷ is set to LFE. If you have a Dolby Digital or DTS processor/receiver, the Low-Pass Frequency is set by the processor/receiver. Consult your owner's manual to learn how to view or change this setting.

## MAINTENANCE AND SERVICE

The enclosure may be cleaned using a soft cloth to remove fingerprints or to wipe off dust.

The grille may be gently vacuumed. Stains may be removed with an aerosol cleaner, following its instructions. Do not use any solvents on the grille.

All wiring connections should be inspected and cleaned or remade periodically. The frequency of maintenance depends on the metals involved in the connections, atmospheric conditions, and other factors, but once per year is the minimum.

If a problem occurs, make sure that all connections are properly made and clean. If a problem exists in one loudspeaker, reverse the connection wires to the left and right system. If the problem remains in the same speaker, then the fault is with the loudspeaker. If the problem appears in the opposite speaker, the cause is in another component or cable. In the event that your subwoofer ever needs service, contact your local Infinity dealer or Infinity directly at 1.516.674.4INF or [www.infinitysystems.com](http://www.infinitysystems.com) for a service center near you.

# PS-10 BLOCK DIAGRAM



## PS-10/PS-12

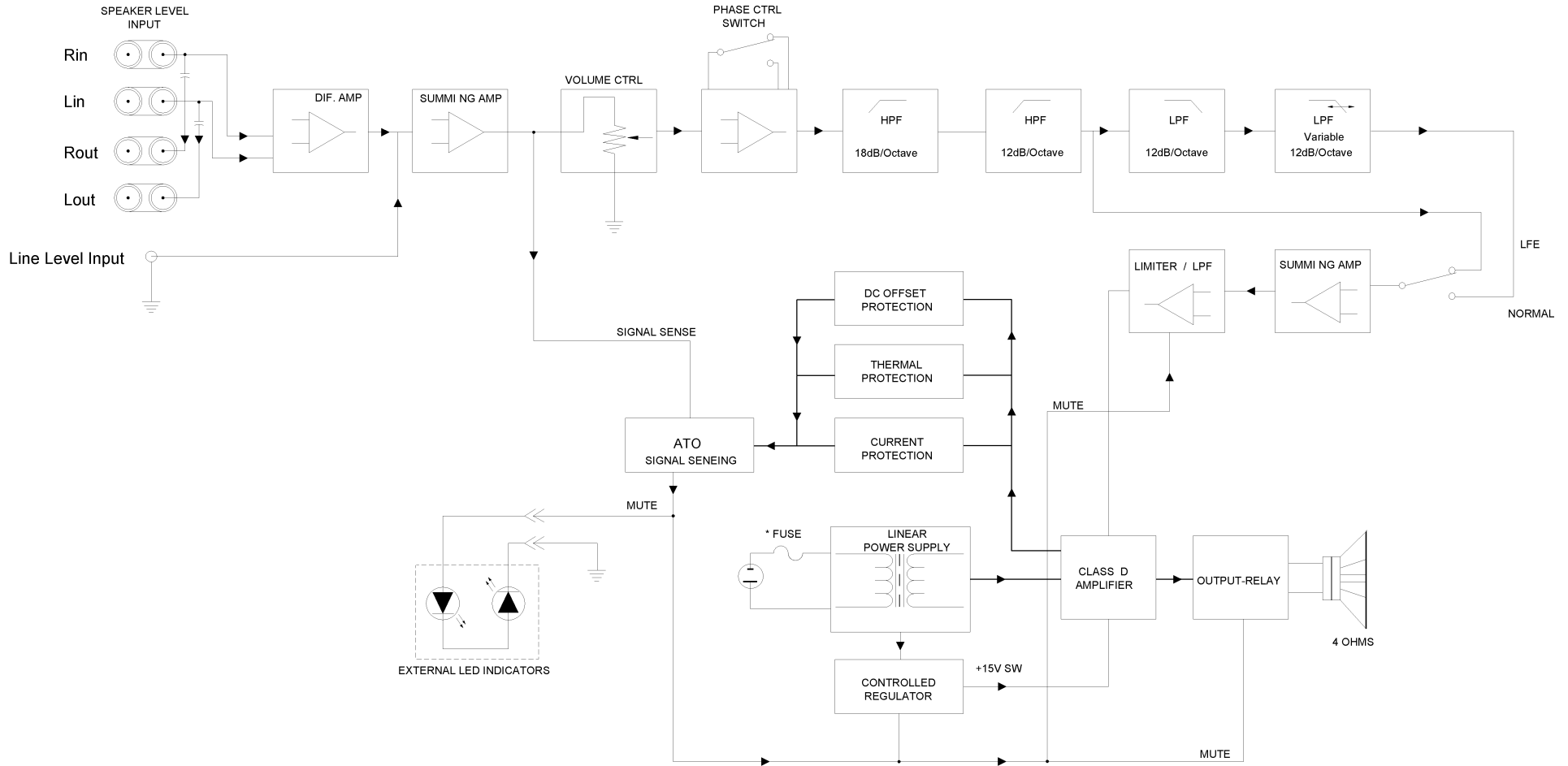

NOTE :  
 120 VAC T1.25A-250V  
 230 VAC T0.8A-250V

# PS-12 BLOCK DIAGRAM

PS-10/PS-12

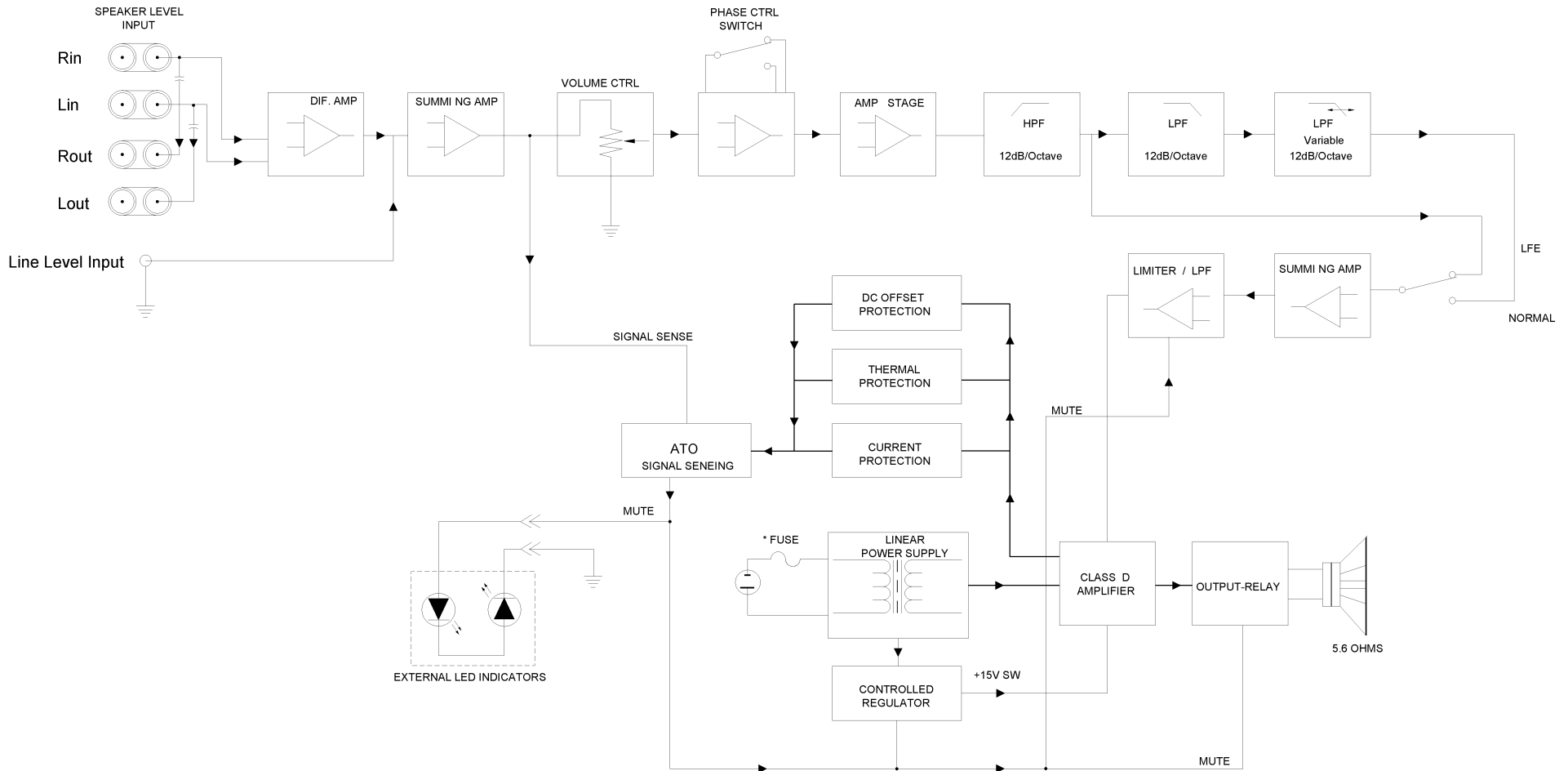

NOTE :  
 120 VAC T2A-250V  
 230 VAC T1.25A-250V

## PS-10/12 Test Set Up and Procedure

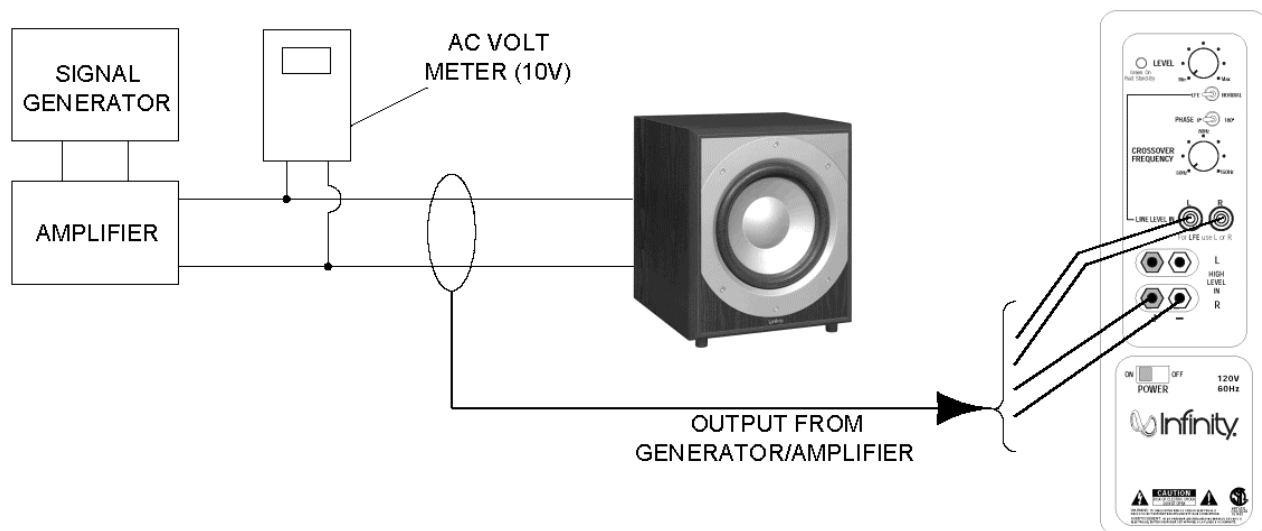

### SYSTEM AURAL SWEEP TEST

#### Equipment needed:

- Function/signal generator/sweep generator
- Integrated Amplifier
- Multimeter
- Speaker cables

#### General Unit Function (UUT = Unit Under Test)

Switches/knobs on the amplifier faceplate:

LFE/Normal to "Normal"

Low Pass Frequency Adjust full CW (150Hz)

Phase switch – either position

1. From the signal generator, Connect both right and left line level inputs (RCA) to signal generator and UUT. Use Y-cable if necessary from mono source.
2. On the amplifier, turn the LEVEL control full Counterclockwise (Min).
3. Turn on generator, adjust to **100mV, 50 Hz**.
4. Plug in UUT; turn the power switch ON. Turn LEVEL control full Clockwise (Max).
5. LED should now be Green; immediate bass response should be heard and felt from rear port tube opening.
6. Turn off generator, turn LEVEL control fully Counterclockwise (Min), disconnect RCA cable.
7. Connect one pair of speaker cables to one set of Speaker Level input terminals on UUT. Cables should be connected to an integrated amplifier fed by the signal generator.
8. Turn on generator and adjust so that speaker level input at the amplifier is **1.3V, 50 Hz**. Turn LEVEL control full Clockwise (Max).
9. Green LED should light; immediate bass response should be heard and felt from the port tube opening.

#### Sweep Function

1. Follow steps 7-10 above, using a sweep generator as a signal source.
2. Sweep generator from 20Hz to 1kHz. Listen to the cabinet and drivers for any rattles, clicks, buzzes or any other noises. If any unusual noises are heard, remove woofer and test.

#### Driver Function (Woofer)

1. Remove woofer from cabinet; detach + and - wire clips.
2. Check DC resistance of woofer; it should be **3.4 ohms ± 10%**.
3. Connect a pair of speaker cables to driver terminals. Cables should be connected to an integrated amplifier fed by a signal generator. Turn on generator and adjust so that speaker level output is **5.0V**.
4. Sweep generator from 20Hz to 1kHz. Listen to driver for any rubbing, buzzing, or other unusual noises.



## TECH TIPS

### Troubleshooting tips and solutions to common service problems

For models: PS-10, PS-12, SUB750, SW-10

TIP# INFTT2003-02 Rev2

**Subject:** Replacing Output MOSFETS

In the event you need to replace MOSFET transistors Q18 or Q22 as part of a repair:

It is important to use ONLY the Infinity part# FE106401110, 051-640001-000, *or* only the brands: International Rectifier, or Fairchild.

Replace both Q18 and Q22 MOSFET's in the circuit, even if only one seems to be damaged.

Do NOT mix & match these components from different manufacturers, or batches. They should be identical.

# Infinity®

## PS-10 Exploded View

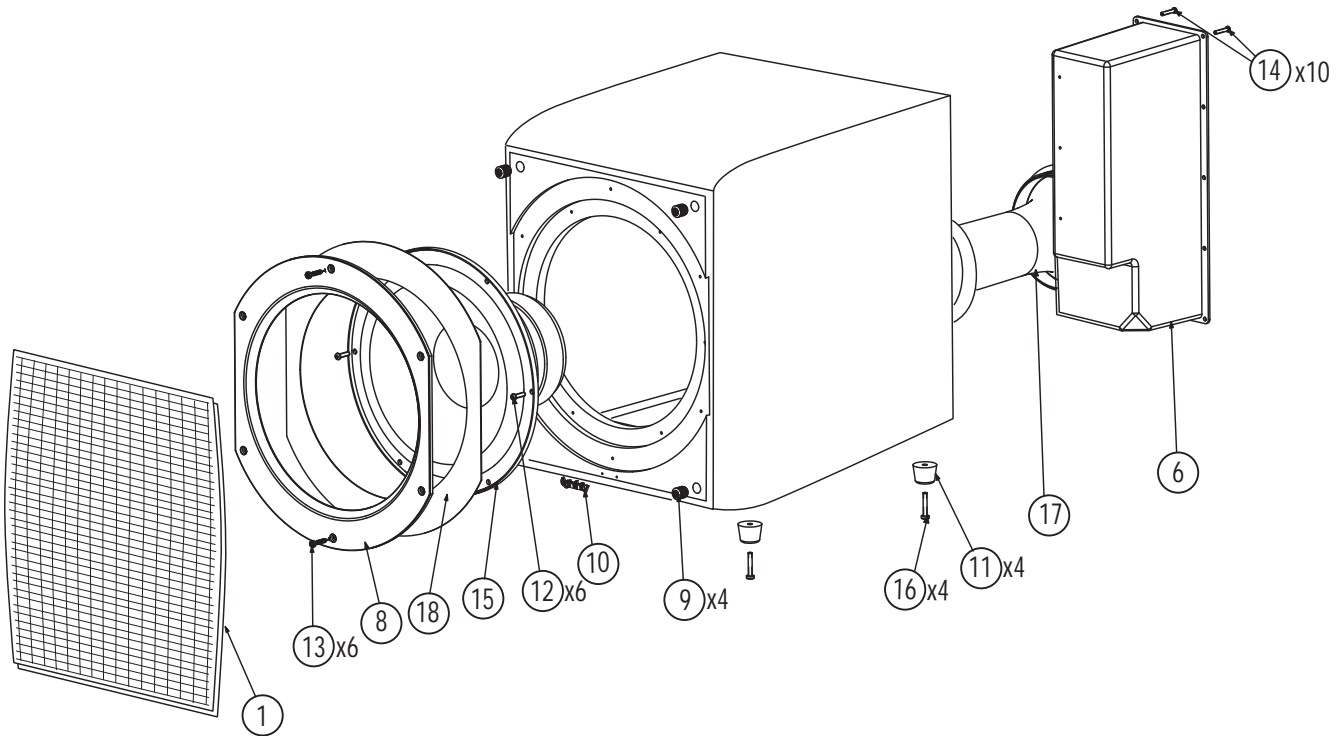

Ref. #	Part Number	Description	Qty
6	Not For Sale	PS-10 AMPLIFIER	1 EA
7	Not For Sale	PS-10 CABINET	1 EA
8	351650-001	TRIM RING, 10"-PS10	1 EA
9	333249-001	CUP, GRILLE	4 EA
10	351781-001	LOGO - PS10/PS12	1 EA
11	330163-001	FOOT, PLASTIC, 1" x 3/4	4 EA
12	883-41110-12	SCR, 8 X 3/4, PAN,PH,PB,BLK ZINC,LCS WFR	6 EA
13	9412730	SCR,TORX HD,3.9X30mm PLATE	6 EA
14	882-41110-12	SCR, 6 X 3/4,PAN,PH,PB,BLK ZINC,LCS AMP	10 EA
15	336649-001	WOOFER, 10" (254mm)C.M.M.D. SHIELDED DCR = 3.3 ohms ±10%	1 EA
16	883-31116-16	SCR, 8 X 1,TR,PH,PB,BLK ZINC,SS FEET	4 EA
17	336079-001	ASY,PORT TUBE	1 EA
18	351515-001	GASKET,FACEPLATE - PS10	1 EA



# PS-12 Exploded View

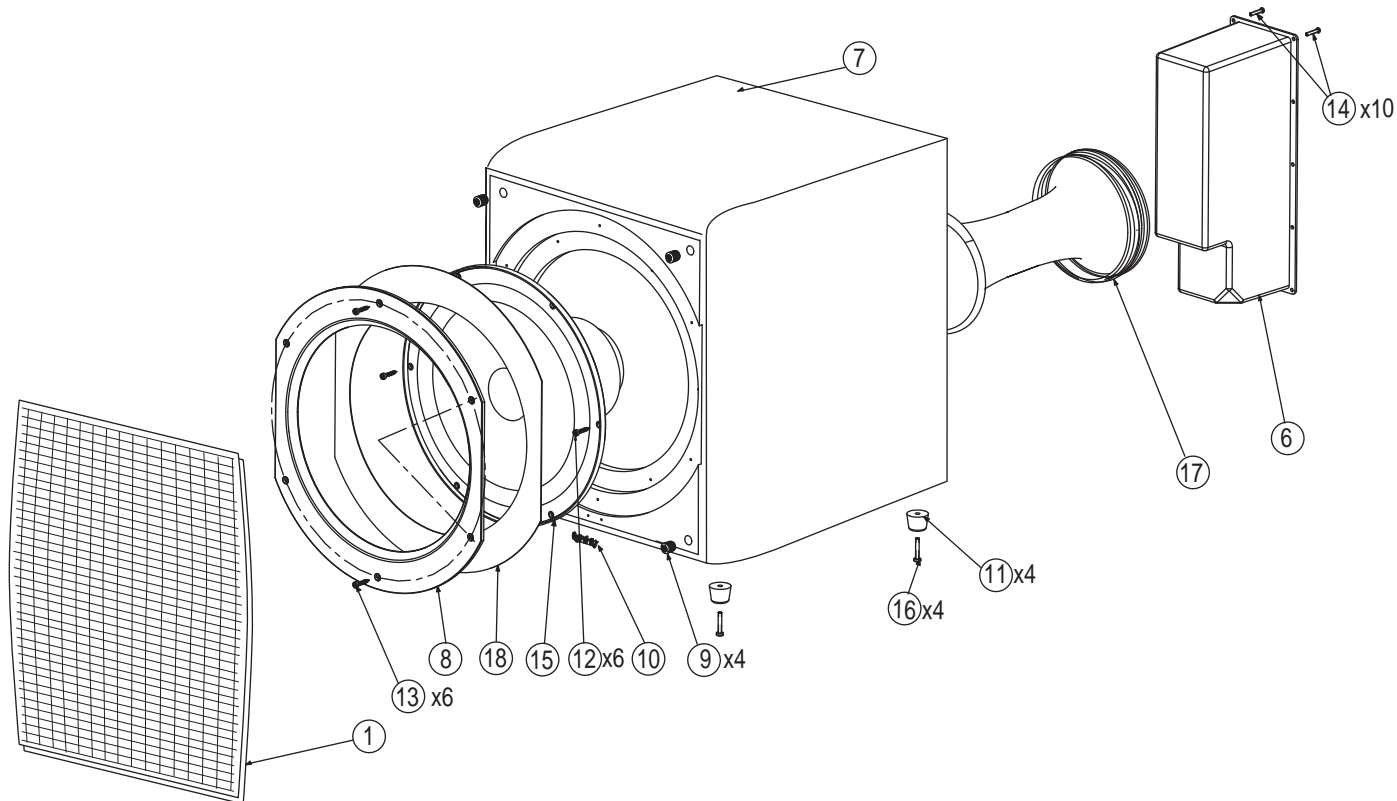

Ref. #	Part Number	Description	Qty
6	Not For Sale	PS-12 AMPLIFIER	1 EA
7	Not For Sale	PS-12 CABINET	1 EA
8	351651-001	TRIM RING, 12"-PS12	1 EA
9	333249-001	CUP, GRILLE	4 EA
10	351781-001	LOGO - PS12/PS12	1 EA
11	330163-001	FOOT, PLASTIC, 1" x 3/4	4 EA
12	883-41110-12	SCR, 8 X 3/4, PAN,PH,PB,BLK ZINC,LCS WFR	6 EA
13	9412730	SCR,TORX HD,3.9X30mm PLATE	6 EA
14	882-41110-12	SCR, 6 X 3/4,PAN,PH,PB,BLK ZINC,LCS AMP	10 EA
15	336056-001	WOOFER,12",SUB DCR = 3.4 ohms ±10%	1 EA
16	883-31116-16	SCR, 8 X 1,TR,PH,PB,BLK ZINC,SS FEET	4 EA
17	336805-001	ASY,PORT TUBE	1 EA
18	352049-001	GASKET,FACEPLATE - PS12	1 EA



# PS-10 Package

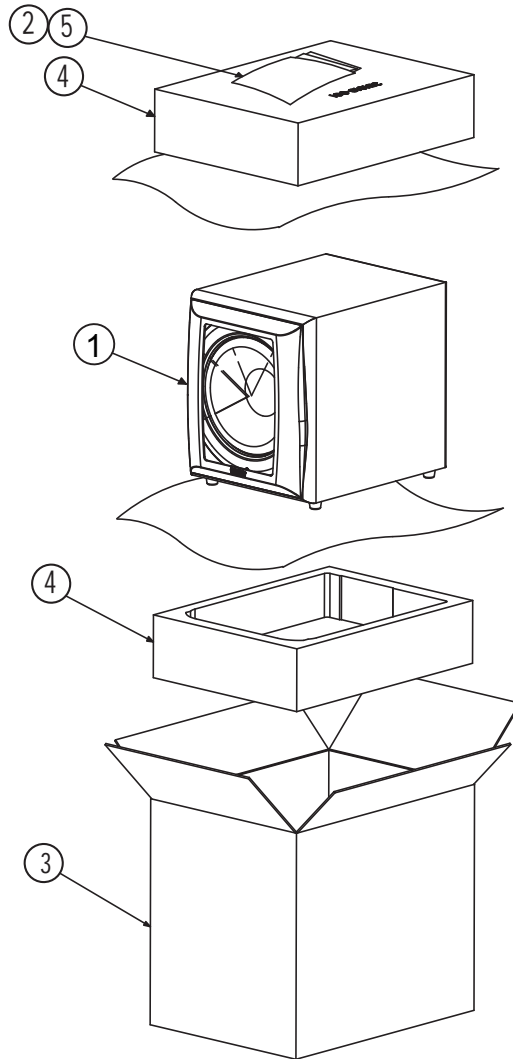

Ref. #	Part Number	Description	Qty
1	351689-001	ASY,GRILLE, BLK, FRNT, PS10BK	1 EA
2	351740-001	MANUAL,OWNERS -PS10/12	1 EA
3	351741-001	CARTON, OUTER - PS10BK-	1 EA
4	351810-001	PAD,END,TOP & BOT-PS10	2 EA
5	352004-001	WARRANTY,CARD, 3/5YR,INFINITY	1 EA





# PS-12 Package

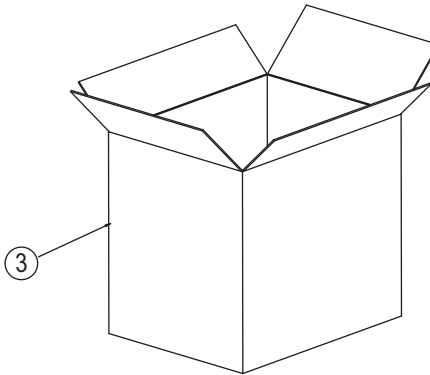
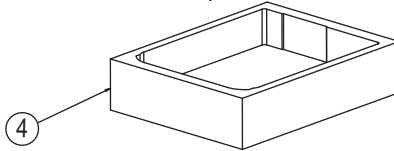
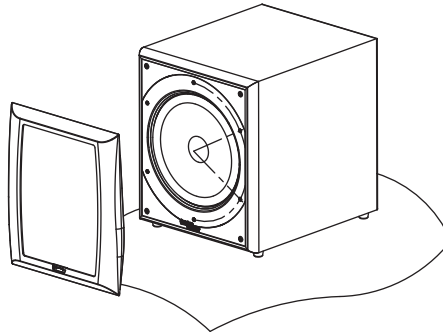
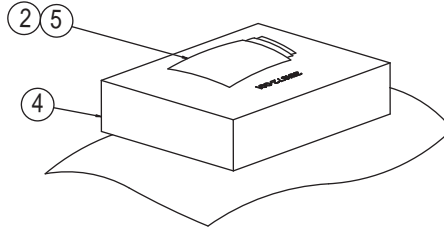

Ref. #	Part Number	Description	Qty
1	351690-001	ASY,GRILLE, BLK, FRNT, PS12BK	1 EA
2	351740-001	MANUAL,OWNERS -PS12/12	1 EA
3	351742-001	CARTON, OUTER - PS12BK-	1 EA
4	351872-001	PAD,END,TOP & BOT-PS12	2 EA
5	352004-001	WARRANTY,CARD, 3/5YR,INFINITY	1 EA

PS-10 Electrical Parts List 120V				
Part Number	Description		Qty	Reference Designator
<i>Resistors</i>				
020-000098-400	Carbon Film	0R 1/8W	4	C22-C24,C31
020-220497-120	Carbon Film	2K2 1/4W J	1	R11
021-100401-120	MOF Resistor	1K 1W J	1	R103
021-220202-120	MOF Resistor	22R 2W(S) J MB Type 15x8	1	R10
021-240405-020	MOF Resistor	2K4/5WS J 17x6	4	R6,9,R7A,R9A
022-500003-020	Resistor KNP	0R05 3WS J FK Type	1	R104
024-000098-120	SMD Resistor	0R 1/8W J 0805	1	R68
024-100298-120	SMD Resistor	10R 1/8W J 0805	2	R81,82
024-100398-120	SMD Resistor	100R 1/8W J 0805	1	R62
024-100498-120	SMD Resistor	1K 1/8W J 0805	8	R79,83,92,95,96,105,108,,65
024-100598-100	SMD Resistor	10K 1/8W F 0805	2	R20,21
024-100598-120	SMD Resistor	10K 1/8W J 0805	8	R2,17,19,37,54,58,63,71
024-100698-100	SMD Resistor	100K 1/8W F 0805	4	R22-25
024-100698-120	SMD Resistor	100K 1/8W J 0805	2	R3,112
024-110598-100	SMD Resistor	11K 1/8W F 0805	1	R98
024-137698-100	SMD Resistor	137K 1/8W F 0805	1	R32
024-150498-120	SMD Resistor	1K5 1/8W J 0805	1	R67
024-160798-120	SMD Resistor	1M6 1/8W J 0805	1	R121
024-162398-101	SMD Resistor	162R 1/8W F 0805	1	R6A
024-169698-100	SMD Resistor	169K 1/8W F 0805	1	R4A
024-180598-100	SMD Resistor	18K 1/8W F 0805	1	R29
024-187698-100	SMD Resistor	187K 1/8W F 0805	1	R45
024-200598-120	SMD Resistor	20K 1/8W J 0805	1	R94
024-220398-120	SMD Resistor	220R 1/8W J 0805	1	R90
024-220498-121	SMD Resistor	2K2 1/8W J 0805	3	R1,87,61
024-220598-120	SMD Resistor	22K 1/8W J 0805	2	R118,39
024-220798-120	SMD Resistor	2M2 1/8W J 0805	1	R80
024-221498-100	SMD Resistor	2K21 1/8W F 0805	1	R5A
024-237598-120	SMD Resistor	23K7 1/8W F 0805	1	R48
024-270498-120	SMD Resistor	2K7 1/8W J 0805	2	R73,64
024-300398-120	SMD Resistor	300R 1/8W J 0805	1	R55
024-300598-120	SMD Resistor	30K 1/8W J 0805	1	R56
024-309398-100	SMD Resistor	309R 1/8W F 0805	1	R2A
024-330498-120	SMD Resistor	3K3 1/8W J 0805	8	R7,8,12-15,59,28
024-330598-120	SMD Resistor	33K 1/8W J 0805	2	R4,5
024-332498-100	SMD Resistor	3K32 1/8W F 0805	2	R26,27
024-390498-120	SMD Resistor	3K9 1/8W J 0805	1	R93
024-390598-120	SMD Resistor	39K 1/8W J 0805	1	R77
024-430498-120	SMD Resistor	4K3 1/8W J 0805	1	R78
024-432498-100	SMD Resistor	4K32 1/8W F 0805	1	R36
024-453598-100	SMD Resistor	45K3 1/8W F 0805	1	R30
024-470298-120	SMD Resistor	47R 1/8W J 0805	2	R101,102
024-470398-120	SMD Resistor	470R 1/8W J 0805	3	R76,99,100
024-470498-120	SMD Resistor	4K7 1/8W J 0805	2	R85,86
024-470598-120	SMD Resistor	47K 1/8W J 0805	4	R44,47,49,107
024-470698-120	SMD Resistor	470K 1/8W J 0805	1	R70
024-470798-120	SMD Resistor	4M7 1/8W J 0805	1	R60
024-510398-120	SMD Resistor	510R 1/8W J 0805	1	R57
024-549498-100	SMD Resistor	5K49 1/8W F 0805	1	R38

Part Number	Description		Qty	Reference Designator
024-560598-120	SMD Resistor	56K 1/8W J 0805	1	R122
024-620398-100	SMD Resistor	620R 1/8W F 0805	2	R16,18
024-680498-120	SMD Resistor	6K8 1/8W J 0805	6	R46,91,40-43
024-680598-120	SMD Resistor	68K 1/8W J 0805	6	R33,34A,31,50,52,66
024-820598-120	SMD Resistor	82K 1/8W J 0805	1	R69
024-887498-100	SMD Resistor	8K87 1/8W F 0805	1	R35A
024-910398-100	SMD Resistor	910R 1/8W F 0805	1	R110
025-010300-000	Thermister	TSE-103 K L:50mm	1	
026-200595-269	VR LEVEL	PN:RD163121R03D-20KBx2(EJ)	1	VR2
026-500495-252	VR 5KA FREQUENCY	PN:RK163111R52B-5KA (EJ)	1	VR1
<i>Capacitors</i>				
031-100244-100	SMD Ceramic Capacitor	0u01/50V K 0805 X7R	7	C33,45,51,66,67,5,10
031-100343-100	SMD Capacitor	100pF/50V J 0805 NPO	3	C16,36,58
031-100344-100	SMD Capacitor	0u1/50V K 0805 X7R	12	C11,42-44,46-49,52,54,55,60
031-100384-100R	SMD Capacitor	0u1/250V K 1206 X7R	2	C3,7
031-220243-103	SMD Capacitor	0u022/50V J 0805 X7R	1	C40
031-220344-100	SMD Capacitor	220pF/50V J 0805 NPO	5	C14,15,20,21,19
031-330444-300	SMD Capacitor	3300pF/50V K 0805 X7R	1	C34
031-470244-102	SMD Capacitor	0u047/50V K 0805 X7R	2	C62,59
031-560243-100	SMD Capacitor	56pF/50V J 0805 NPO	2	C57,61
031-560343-102	SMD Capacitor	560pF/50V J 0805 NPO	1	C56
032-100484-200	Mylar Capacitor	1uF/250V K P:15	2	C70,C70B
032-270343-301	Mylar Capacitor	0u27/63V J P:5	1	C29
032-820244-200	Mylar Capacitor	0u082/100V K (R)	1	C30
033-470464-270	NPE Capacitor	4u7/100V K10 (R)1015 GNE	1	C73
033-680464-270	NPE Capacitor	6u8/100V K10 (R)1020 GNE	1	C72
034-100525-300	Electrolytic Capacitor	10uF/25V M (R)0511 P:5	1	C35
034-100625-300	Electrolytic Capacitor	100uF/25V M (R)6.3x11 P:5	1	C64
034-220525-301	Electrolytic Capacitor	22uF/25V M (R)5x11 P:5	5	C4,9,41,50,53
034-220615-301	Electrolytic Capacitor	220uF/16V M (R)0611 P:5	1	C37
034-330515-000	Electrolytic Capacitor	33uF/16V M (R)0511 P:5	1	C39
034-330525-300	Electrolytic Capacitor	33uF/25V M (R)0511 P:5	1	C1
034-330615-300	Electrolytic Capacitor	330uF/16V M (R)0812 P:5	2	C12,78
034-330780-300	Electrolytic Capacitor	3300uF/80V M (R)22x48	2	C6,8
034-470415-301	Electrolytic Capacitor	4u7/50V M (R)0511 P:5	1	C2
034-470615-301	Electrolytic Capacitor	470uF/16V M (R)0812 P:5	1	C65
035-100393-301	Mylar Capacitor	0u1/63V J P:5	2	C28,C2A
035-220393-300	PE Capacitor	0u22/63V J P:5	1	C27
035-470293-300	PE Capacitor	0u047/63V J P:5	1	C1A
035-470353-301	ESKCapacitor	0u47/63V J P:5m/m	2	C25,26
038-100363-300	MPE Capacitor	0u1/100V J	2	C68,69
039-100390-100	Safety Capacitor	0u1/275V PN:XG275M104VSL7	1	
<i>Semiconductors</i>				
050-505200-001	LED	PN:LT-2402-21	1	
051-000600-100	NPN Transistor	PN:MPSW06RLRA TO-92	2	Q2,Q16
051-003100-000	NPN Transistor	PN:TIP 31C TO-220 (MOSPEC)	1	Q4
051-005600-100	PNP Transistor	PN:MPSW56RLRA TO-92	1	Q3
051-222200-100	NPN Transistor	PN:MPS2222ARLRA TO-92	1	Q21
051-290700-100	PNP Transistor	PN:MPS2907A RLRA TO-92	2	Q19,23

Part Number	Description		Qty	Reference Designator
051-540101-000	PNP Transistor	PN:2N5401 TO-92	1	Q1
051-555100-000	NPN Transistor	PN:2N5551 TO-92	1	Q17
051-640001-000	MOSFET N-Channel	PN:IRF640N TO-220 (IR)	2	Q18,22
052-400080-000	Bridge Regulator	PN:RS804 400V,8A	1	BR1
053-211100-000	IC;DIP,Driver	PN:IR2111 8PIN (IR)	1	U7
054-000100-100	SMD DIODE	PN:ES1D 200V 1A	5	D5,26,29,33,38
054-001002-100	SMD ZENER DIODE	PN:BZX84C10 10V SOT-23	1	D35
054-001501-100	SMD ZENER DIODE	PN:BZX84C15 15V SOT-23	3	D6,7,9
054-007200-100	SMD IC Dual Op-amp	PN:TL072CDR SO-8	2	U5,6,
054-007400-100	SMD IC; Quad Op-amp	PN:TL074CDR	2	U2,3
054-011400-100	SMD Transistor	PN:DTC114TKA SMT3	1	Q7
054-033904-100	SMD Transistor	PN:MMBT3904LT1 SOT23	7	Q11,14,13,5,8,25,9
054-033906-100	SMD Transistor	PN:MMBT3906LT1 SOT23	4	Q6,10,12,15
054-045580-100	SMD IC; Dual Op-amp	PN:NJM4558M-TE3 DMP-8	1	U4
054-050601-100	SMD ZENER DIODE	PN:BZX84C5V6 5.6V SOT-23	3	D24,36,37
054-414803-100	SMD DIODE	PN:LL4148 (Wishay)	12	D1-4,8,27,28,30-32,34,39,
054-540100-100	SMD Transistor	PN:MMBT5401 LT1 SOT-23	3	Q20,24,26
<i>Miscellaneous</i>				
041-115001-000	Bead Coil	YT-10911	1	L5
042-010053-003	Transformer	YT-10616-4	1	PT1
043-300101-000	Inductor	30uH YT-10033	1	L2
043-324300-000	Inductor	324uH YT-10778	1	L4
043-560200-000	Inductor	56uH YT-10779	1	L1
043-700101-000	Toroidal Inductor	70uH YT-10682	1	L3
044-100100-000	SMD Ferrite Bead	PN:321611 600R/100MHz 1206	1	
061-020000-000	Knob ABS	φ20x15m/m UL94V-0 blk	2	
061-314002-000	Strain Relief	P/N SB4F-2	1	
061-400014-000	Rubber Foot	ID:6.2 OD:11.5 t=2mm blk	1	
061-700044-000	Mycar	13x18mm TO-220	1	
063-010012-000	Bracket for Power Transisto	P/N:TRK-1	1	
063-321101-000	Plate	322x105.7x15mm BLK ABS-94V0	1	
063-531808-000	Bucket	322x105.7x146.5mm blk (94VO)	1	
065-100200-000	UL Sleeve	φ2.5 F32-2.5(blk) 125□	1	
071-100851-000	Washer	ID=5.1 OD=12 t=1m/m	1	
072-010007-000	RCA	SCJ-1020 2P(G) WHT,RED	1	
072-040039-000	Terminal	PC205 (t=0.8m/m) T205MA	1	
072-040064-000	Terminal	PC250(t=0.8),T250MA	1	
072-040096-000	Terminal	(t=0.8mm) PC187(0.8)	1	
072-040169-000	Connector	2 PIN JS-1001-2 P:2.5mm	1	
072-060170-000	B.P.	W / Accessory Parts	1	
072-060213-000	BP Plug	PN:A414B-3A Blk	1	
072-060214-000	BP Plug	PN:A414R-3A Red	1	
073-032088-600	Black anodized	58x32x70mm	1	
073-050001-000	Fuse Clip	P/N:CFFH1206	1	
074-020018-000	Rocker SW	PN:RF1003-BB4-0	1	
074-030002-000	Tolggle SW	PN:L101-T2B4QE	1	
074-300018-000	Relay	PN:943-1C-48D	1	
082-022607-000	Wire Set #26 UL1007	L=74mm Black/Wht 2P Housing	1	
083-041802-009	UL Power Cord	SPT-2 Black	1	
093-105202-300	Fuse:UL GSL(2AG)	FUSE:2A,250V,5*20mm	1	F1
181-911600-161	Wire set #16AWG UL1007	Black L=610mm	1	

Part Number	Description		Qty	Reference Designator
181-911655-135	Wire set #16AWG UL1007	Green L=610mm	1	
181-921600-000	BLK Wire #16 UL1015	T187 L:140mm	1	
181-921699-000	WHT Wire #16 UL1015	T187 L:160mm	1	
008-061215-000	Gasket C4305	12x15 t=5mm CR	1	
008-062002-002	Gasket	PN:L-32 200x20mm t=5mm PORON	1	
008-062002-012	Gasket C4305	200x20mm t=2mm CR4305	1	
008-063208-000	Gasket C4305	321x8 t=1mm CR	1	
008-069304-000	Gasket C4305	93x4 t=1mm CR	1	

<b>PS-12 Electrical Parts List 120V</b>				
<b>Part Number</b>	<b>Description</b>		<b>Qty</b>	<b>Reference Designator</b>
<i>Resistors</i>				
020-000098-400	Carbon Film	0R 1/8W	4	C22-C24,31
020-220497-120	Carbon Film	2K2 1/4W J	1	R11
021-100401-120	MOF Resistor	1K 1W J	1	R103
021-220202-120	MOF Resistor	22R 2W(S) J MB TYPE 15x8	1	R10
021-240405-020	MOF Resistor	2K4/5WS J 17x6	4	R6,9,R7A,R9A
022-500003-020	KNP Resistor	0R05 3WS J FK TYPE	1	R104
024-000098-120	SMD Resistor	0R 1/8W J 0805	1	R68
024-100298-120	SMD Resistor	10R 1/8W J 0805	2	R81,82
024-100398-120	SMD Resistor	100R 1/8W J 0805	1	R62
024-100498-120	SMD Resistor	1K 1/8W J 0805	8	R79,83,92,95,96,105,108,65
024-100598-100	SMD Resistor	10K 1/8W F 0805	2	R20,21
024-100598-120	SMD Resistor	10K 1/8W J 0805	8	R2,17,19,37,54,58,63,71
024-100698-100	SMD Resistor	100K 1/8W F 0805	4	R22-25
024-100698-120	SMD Resistor	100K 1/8W J 0805	2	R3,112
024-110598-100	SMD Resistor	11K 1/8W F 0805	1	R98
024-137698-100	SMD Resistor	137K 1/8W F 0805	1	R32
024-150498-120	SMD Resistor	1K5 1/8W J 0805	1	R67
024-160798-120	SMD Resistor	1M6 1/8W J 0805	1	R121
024-174398-100	SMD Resistor	174R 1/8W F 0805	1	R6A
024-180598-100	SMD Resistor	18K 1/8W F 0805	1	R29
024-187698-100	SMD Resistor	187K 1/8W F 0805	1	R45
024-200598-120	SMD Resistor	20K 1/8W J 0805	1	R94
024-205598-100	SMD Resistor	20K5 1/8W F 0805	1	R35A
024-220398-120	SMD Resistor	220R 1/8W J 0805	1	R90
024-220498-121	SMD Resistor	2K2 1/8W J 0805	3	R1,87,61
024-220598-120	SMD Resistor	22K 1/8W J 0805	1	R118
024-220798-120	SMD Resistor	2M2 1/8W J 0805	1	R80
024-237598-120	SMD Resistor	23K7 1/8W F 0805	1	R48
024-243498-100	SMD Resistor	2K43 1/8W F 0805	1	R36
024-270498-120	SMD Resistor	2K7 1/8W J 0805	2	R73,64
024-300398-120	SMD Resistor	300R 1/8W J 0805	1	R55
024-300598-120	SMD Resistor	30K 1/8W J 0805	1	R56
024-330498-120	SMD Resistor	3K3 1/8W J 0805	8	R7,8,12-15,59,28
024-330598-120	SMD Resistor	33K 1/8W J 0805	2	R4,5
024-332498-100	SMD Resistor	3K32 1/8W F 0805	2	R26,27
024-348598-100	SMD Resistor	34K8 1/8W F 0805	1	R39
024-390498-120	SMD Resistor	3K9 1/8W J 0805	2	R93,38
024-390598-120	SMD Resistor	39K 1/8W J 0805	1	R77
024-430498-120	SMD Resistor	4K3 1/8W J 0805	1	R78
024-453598-100	SMD Resistor	45K3 1/8W F 0805	1	R30
024-470298-120	SMD Resistor	47R 1/8W J 0805	2	R101,102

Part Number	Description		Qty	Reference Designator
024-470398-120	SMD Resistor	470R 1/8W J 0805	3	R76,99,100
024-470498-120	SMD Resistor	4K7 1/8W J 0805	2	R85,86
024-470598-120	SMD Resistor	47K 1/8W J 0805	4	R44,47,49,107
024-470698-120	SMD Resistor	470K 1/8W J 0805	1	R70
024-470798-120	SMD Resistor	4M7 1/8W J 0805	1	R60
024-510398-120	SMD Resistor	510R 1/8W J 0805	1	R57
024-560598-120	SMD Resistor	56K 1/8W J 0805	1	R122
024-562398-100	SMD Resistor	562R 1/8W F 0805	1	R5A
024-620398-100	SMD Resistor	620R 1/8W F 0805	2	R16,18
024-680498-120	SMD Resistor	6K8 1/8W J 0805	6	R46,91,40-43
024-680598-120	SMD Resistor	68K 1/8W J 0805	6	R33,34A,31,50,52,66
024-768398-100	SMD Resistor	768R 1/8W F 0805	1	R2A
024-820598-120	SMD Resistor	82K 1/8W J 0805	1	R69
024-909598-100	SMD Resistor	90K9 1/8W F 0805	1	R4A
024-910398-100	SMD Resistor	910R 1/8W F 0805 TPAING	1	R110
025-010300-000	Thermister	TSE-103 K L:50mm	1	
026-200595-269	VR FREQUENCY	PN:RD163121R03D-20KBx2(EJ)	1	VR2
026-500495-252	VR 5KA LEVEL	PN:RK163111R52B-5KA (EJ)	1	VR1
<i>Capacitors</i>				
031-100244-100	SMD Ceramic Capacitor	0u01/50V K 0805 X7R	7	C33,45,51,66,67,5,10
031-100343-100	SMD Capacitor	100pF/50V J 0805 NPO	3	C16,36,58
031-100344-100	SMD Capacitor	0u1/50V K 0805 X7R	12	C11,42-44,46-49,52,54,55,60
031-100384-100F	SMD Capacitor	0u1/250V K 1206 X7R	2	C3,7
031-220243-103	SMD Capacitor	0u022/50V J 0805 X7R	1	C40
031-220344-100	SMD Capacitor	220pF/50V J 0805 NPO	5	C14,15,20,21,19
031-330444-300	SMD Capacitor	3300pF/50V K 0805 X7R	1	C34
031-470244-102	SMD Capacitor	0u047/50V K 0805 X7R	2	C62,59
031-560243-100	SMD Capacitor	56pF/50V J 0805 NPO	2	C57,61
031-560343-102	SMD Capacitor	560pF/50V J 0805 NPO	1	C56
032-100484-200	Mylar Capacitor	1uF/250V K P:15	2	C70,C70B
032-330363-200	Mylar Capacitor	0u33/100V J P:10 (R)	1	C29
032-820244-200	Mylar Capacitor	0u082/100V K (R)	1	C30
033-470464-270	NPE Capacitor	4u7/100V K10 (R)1015 GNE	1	C73
033-680464-270	NPE Capacitor	6u8/100V K10 (R)1020 GNE	1	C72
034-100525-300	Electrolytic Capacitor	10uF/25V M (R)0511 P:5	1	C35
034-100625-300	Electrolytic Capacitor	100uF/25V M (R)6.3x11 P:5	1	C64
034-220525-301	Electrolytic Capacitor	22uF/25V M (R)5x11 P:5	5	C4,9,41,50,53
034-220615-301	Electrolytic Capacitor	220uF/16V M (R)0611 P:5	1	C37
034-330515-000	Electrolytic Capacitor	33uF/16V M (R)0511 P:5	1	C39
034-330525-300	Electrolytic Capacitor	33uF/25V M (R)0511 P:5	1	C1
034-330615-300	Electrolytic Capacitor	330uF/16V M (R)0812 P:5	2	C12,78
034-330780-300	Electrolytic Capacitor	3300uF/80V M (R)22x48	2	C6,8
034-470415-301	Electrolytic Capacitor	4u7/50V M (R)0511 P:5	1	C2

Part Number	Description		Qty	Reference Designator
034-470615-301	Electrolytic Capacitor	470uF/16V M (R)0812 P:5	1	C65
035-100393-301	Mylar Capacitor	0u1/63V J P:5	2	C28,2A
035-220393-300	PE Capacitor	0u22/63V J P:5	1	C27
035-470293-300	PE Capacitor	0u047/63V J P:5	1	C1A
035-470353-301	ESK Capacitor	0u47/63V J P:5m/m	2	C25,26
038-100363-300	MPE Capacitor	0u1/100V J	2	C68,69
039-100390-100	Safety Capacitor	0u1/275V PN:XG275M104VSL7	1	
<i>Semiconductors</i>				
050-505200-001	LED	PN:LT-2402-21	1	
051-000600-100	NPN Transistor	PN:MPSW06RLRA TO-92 (ON)	2	Q2,Q16
051-003100-000	NPN Transistor	PN:TIP 31C TO-220 (MOSPEC)	1	Q4
051-005600-100	PNP Transistor	PN:MPSW56RLRA TO-92 (ON)	1	Q3
051-222200-100	NPN Transistor	PN:MPS2222ARLRA TO-92	1	Q21
051-290700-100	PNP Transistor	PN:MPS2907A RLRA TO-92	2	Q19,23
051-540101-000	PNP Transistor	PN:2N5401 TO-92	1	Q1
051-555100-000	NPN Transistor	PN:2N5551 TO-92	1	Q17
051-640001-000	MOSFET N-Channel	PN:IRF640N TO-220 (IR)	2	Q18,22
052-400080-000	Bridge Regulator	PN:RS804 400V,8A	1	BR1
053-211100-000	IC;DIP, Driver	PN:IR2111 8PIN (IR)	1	U7
054-000100-100	SMD DIODE	PN:ES1D 200V 1A	5	D5,26,29,33,38
054-001002-100	SMD ZENER DIODE	PN:BZX84C10 10V SOT-23	1	D35
054-001501-100	SMD ZENER DIODE	PN:BZX84C15 15V SOT-23	3	D6,7,9
054-007200-100	SMD IC	PN:TL072CDR SO-8 (TI)	2	U5,6
054-007400-100	SMD IC;(OP)	PN:TL074CDR (TI)	2	U2,3
054-011400-100	SMD Transistor	PN:DTC114TKA SMT3 (ROHM)	1	Q7
054-033904-100	SMD Transistor	PN:MMBT3904LT1 SOT23 (ON)	7	Q11,14,13,5,8,25,9
054-033906-100	SMD Transistor	PN:MMBT3906LT1 SOT23 (ON)	4	Q6,10,12,15
054-045580-100	SMD IC;(OP)	PN:NJM4558M-TE3 DMP-8	1	U4
054-050601-100	SMD ZENER DIODE	PN:BZX84C5V6 5.6V SOT-23	3	D24,36,37
054-414803-100	SMD DIODE	PN:LL4148 (Wishay)	12	D1-4,8,27,28,30-32,34,39,
054-540100-100	SMD Transistor	PN:MMBT5401 LT1 SOT-23	3	Q20,24,26
<i>Miscellaneous</i>				
061-020000-000	Knob ABS	φ20x15m/m UL94V-0 BLK	2	
061-314002-000	Strain Relief	P/N SB4F-2	1	
061-400014-000	Rubber Foot	ID:6.2 OD:11.5 t=2mm BLK	1	
061-700044-000	Mycar	13x18mm TO-220	1	
063-010012-000	Bracket - Power Transistor	P/N:TRK-1	1	
063-321101-000	Plate	322x105.7x15mm BLK ABS-94V0	1	
063-531808-000	Bucket	322x105.7x146.5mm BLK (94VO)	1	
065-100200-000	UL Sleeve	φ2.5 F32-2.5 125□	1	
071-100608-100	Fiber Washer	OD=8mm ID=3.2 t=1 (red)	1	



Part Number	Description		Qty	Reference Designator
071-100851-000	Washer	ID=5.1 OD=12 t=1m/m	1	
072-010007-000	RCA	SCJ-1020 2P(G) WHT,RED	1	CONN1
072-040039-000	Terminal	PC205 (t=0.8m/m) T205MA	1	S-
072-040064-000	Terminal	PC250(t=0.8),T250MA	1	S+
072-040096-000	Terminal	(t=0.8mm) PC187(0.8)	1	AC1,AC3,T1,T2,AC2,SW2,SW4
072-040169-000	Connector	2 PIN JS-1001-2 P:2.5mm	1	
072-060170-000	B.P.	W / Accessory Parts	1	BP/IP
072-060213-000	BP Plug	PN:A414B-3A RCA JAM blk	1	
072-060214-000	BP Plug	PN:A414R-3A RCA JAM red	1	
073-032088-600	Black anodized	58x32x70mm	1	
073-050001-000	Fuse Clip	P/N:CFFH1206	1	
074-020018-000	Rocker SW	PN:RF1003-BB4-0	1	
074-030002-000	Toggle SW	PN:L101-T2B4QE	1	SW5,SW6
074-300018-000	Relay	PN:943-1C-48D	1	K1
082-022607-000	Wire Set #26 UL1007	L=74mm blk/whe 2P Housing	1	
083-041802-009	UL Power Cord	SPT-2 blk	1	
093-105202-300	Fuse:UL GSL(2AG)	FUSE:2A,250V,5*20mm	1	F1
181-911600-161	Wire Set #16AWG UL1007	Black L=610mm	1	
181-911655-135	Wire Set #16AWG UL1007	Green L=610mm	1	
181-921600-000	BLK Wire #16 UL1015	T187 L:140mm	1	
181-921699-000	WHT Wire #16 UL1015	T187 L:160mm	1	
008-061215-000	Gasket C4305	12x15 t=5mm CR	1	
008-062002-002	Gasket	L-32 200x20mm t=5mm PORON	1	
008-062002-012	Gasket C4305	200x20mm t=2mm CR4305	1	
008-063208-000	Gasket C4305	321x8 t=1mm CR	1	
008-069304-000	Gasket C4305	93x4 t=1mm CR	1	
041-115001-000	Bead Coil	YT-10911	1	L5
042-010053-003	Transformer	YT-10616-4	1	PT1
043-300101-000	Inductor	30uH YT-10033	1	L2
043-324300-000	Inductor	324uH YT-10778	1	L4
043-560200-000	Inductor	56uH YT-10779	1	L1
043-700101-000	Toroidal Inductor	70uH YT-10682	1	L3
044-100100-000	SMD Ferrite Bead	PN:321611 600R/100MHz 1206	2	FB1,FB2

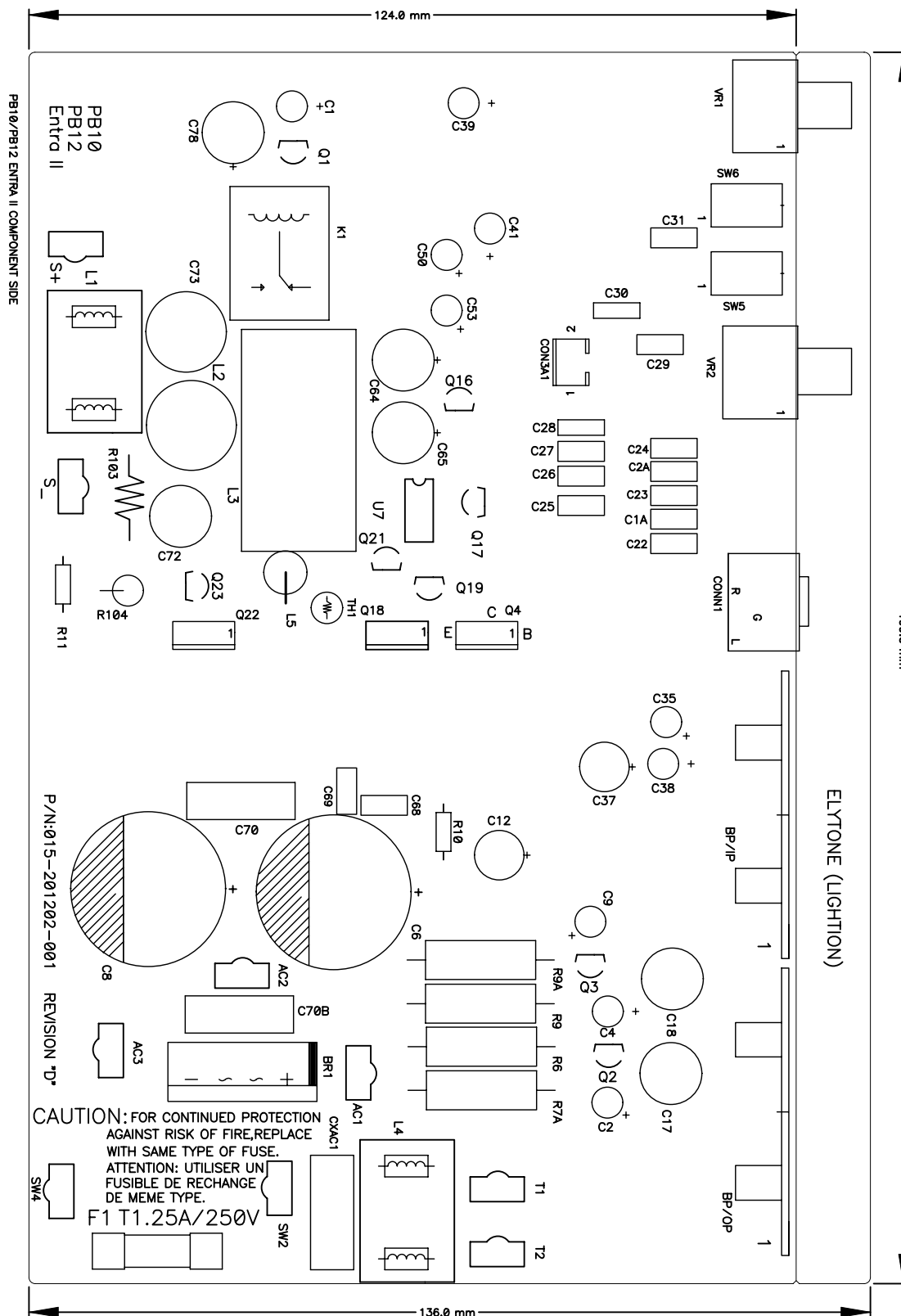

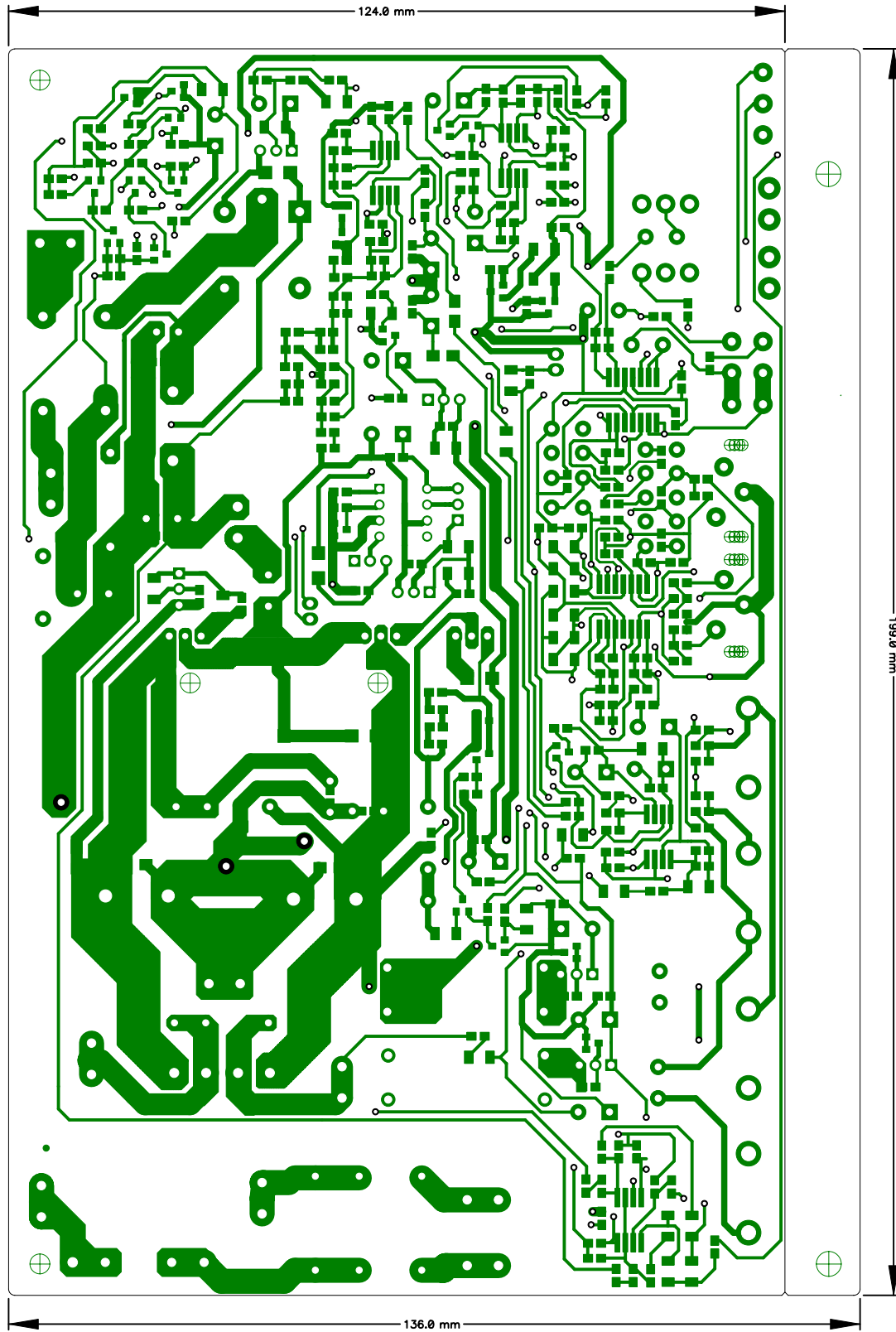

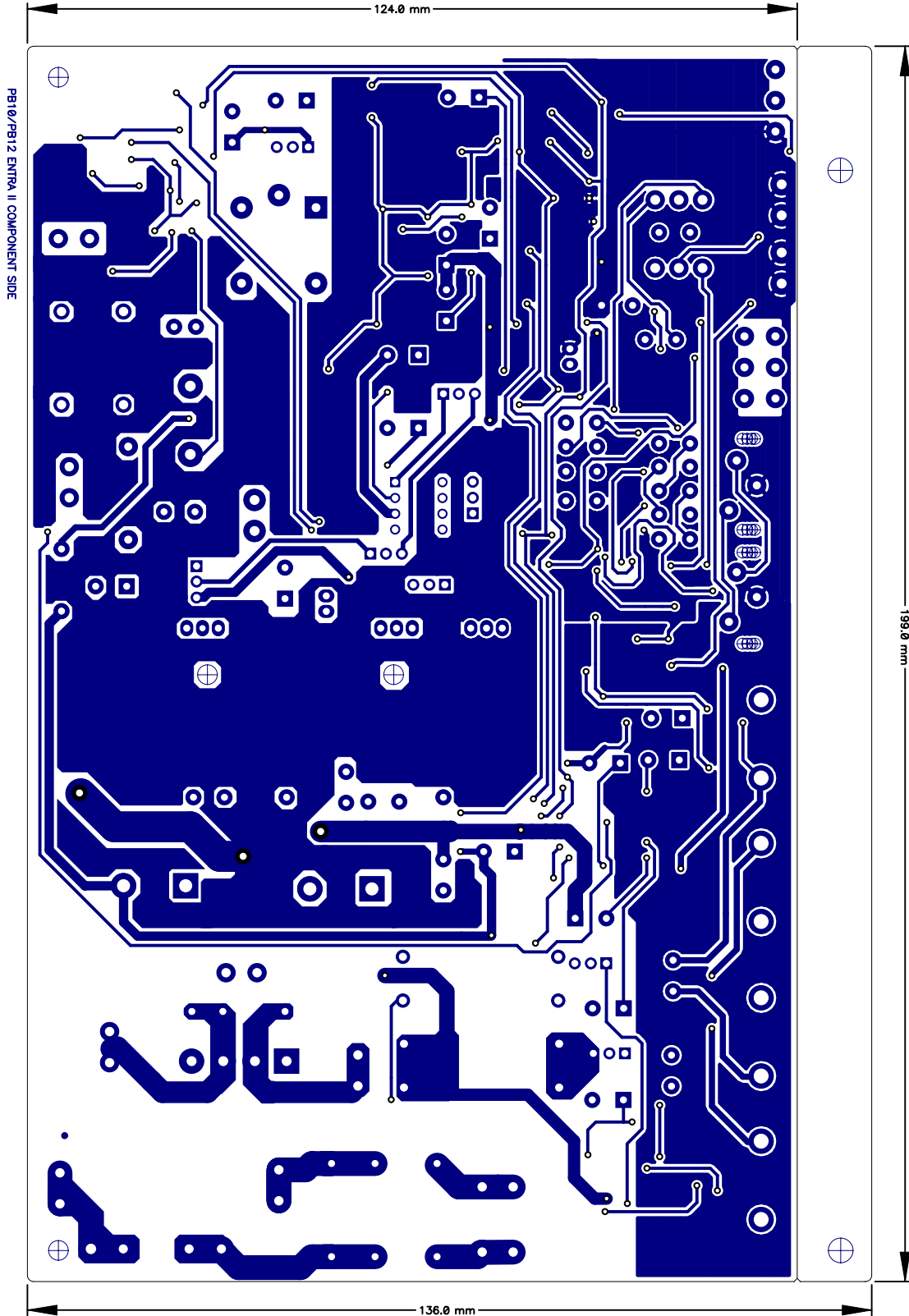

# Integrated Circuit Diagrams

OPAMP, QUAD 14P TL074  
U2,3

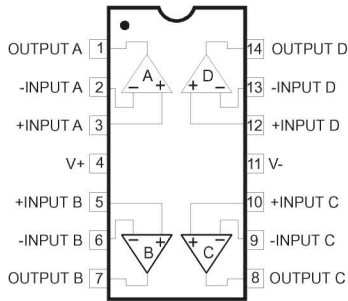

OPAMP, DUAL 8PIN  
TL072, NJM4558M  
U4-6

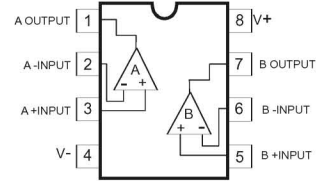

IR2111 U7

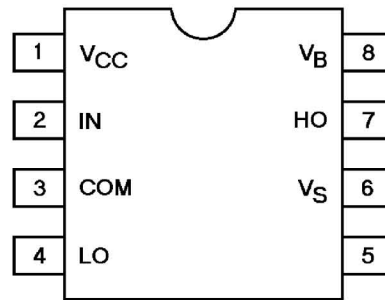

TRANS, NPN T0220  
TIP31C Q4

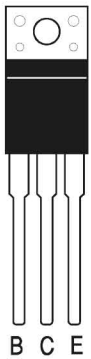

MOSFET, IRF640 T0220  
Q18,22

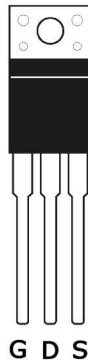

- \* MMBT3904LTI SOT23,
- \* MMBT3906LTI SOT23,
- \* DTC114TK SMT3
- \* MMBT5401 LTI

Q5-15,20,24,26

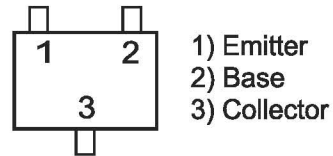

\* PREFIX MAY BE "FMMT"

TRANS NPN MPSW06,  
MPS2222A, 2N5551

Q2,16,17,21

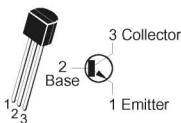

TRANS PNP MPSW56, MPS2709A, 2N5401

Q1,3,19,23

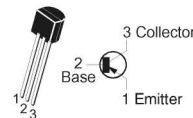

PS-10/PS-12

PS-10 SCHEMATICS

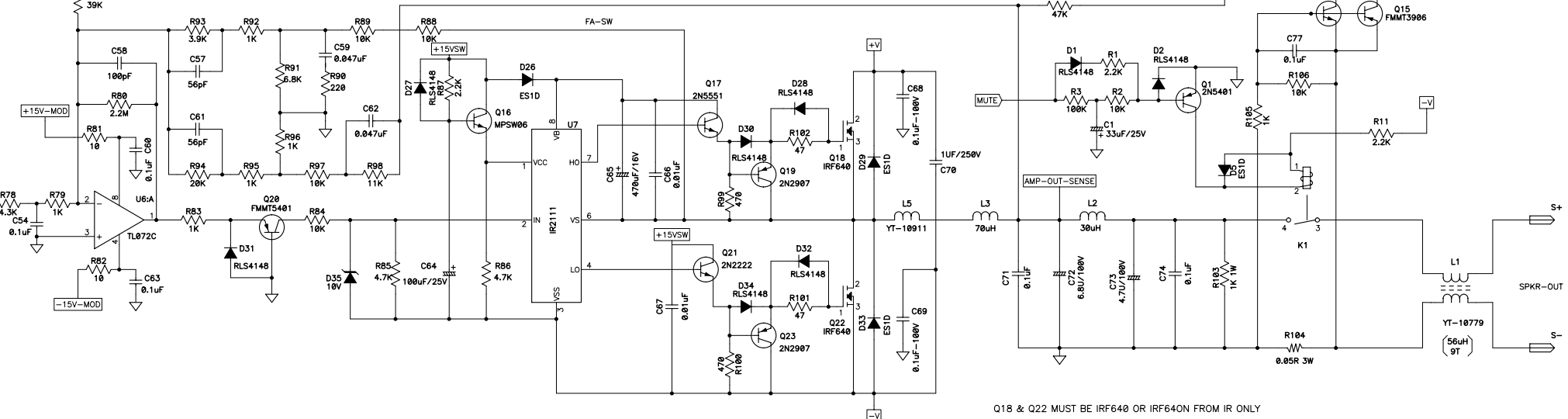
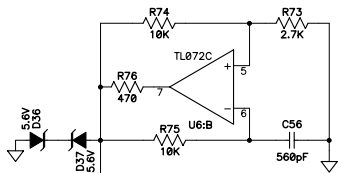
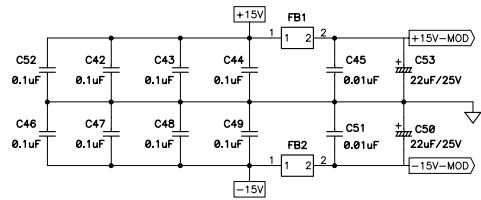

Q18 & Q22 MUST BE IRF640 OR IRF640N FROM IR ONLY

SCH : Rev.P1E, PCB : Rev.P1B.

351647-001

Rev:	Notes:	Date:	Rev:	Notes:	Date:	Draw by	Designed by	Checked by	Approved By	Customer:	INFINITY
P1A	SUB DESIGN CREATED FROM PB12 AMP	2003/03/18								P/N:	416-0321105
										Model no:	PS-10/120V
										Sch name:	POWER AMP PCB
										Issue no:	ET-01-21-4256
										Date:	2003/05/20
										Sheet:	12 Rev: 01
										Size:	A2 Author:VITA

音律電子股份有限公司  
 ELYTONE ELECTRONIC CO.,LTD.  
 TEL:+886-2-2671-2071  
 FAX:+886-2-2672-5943

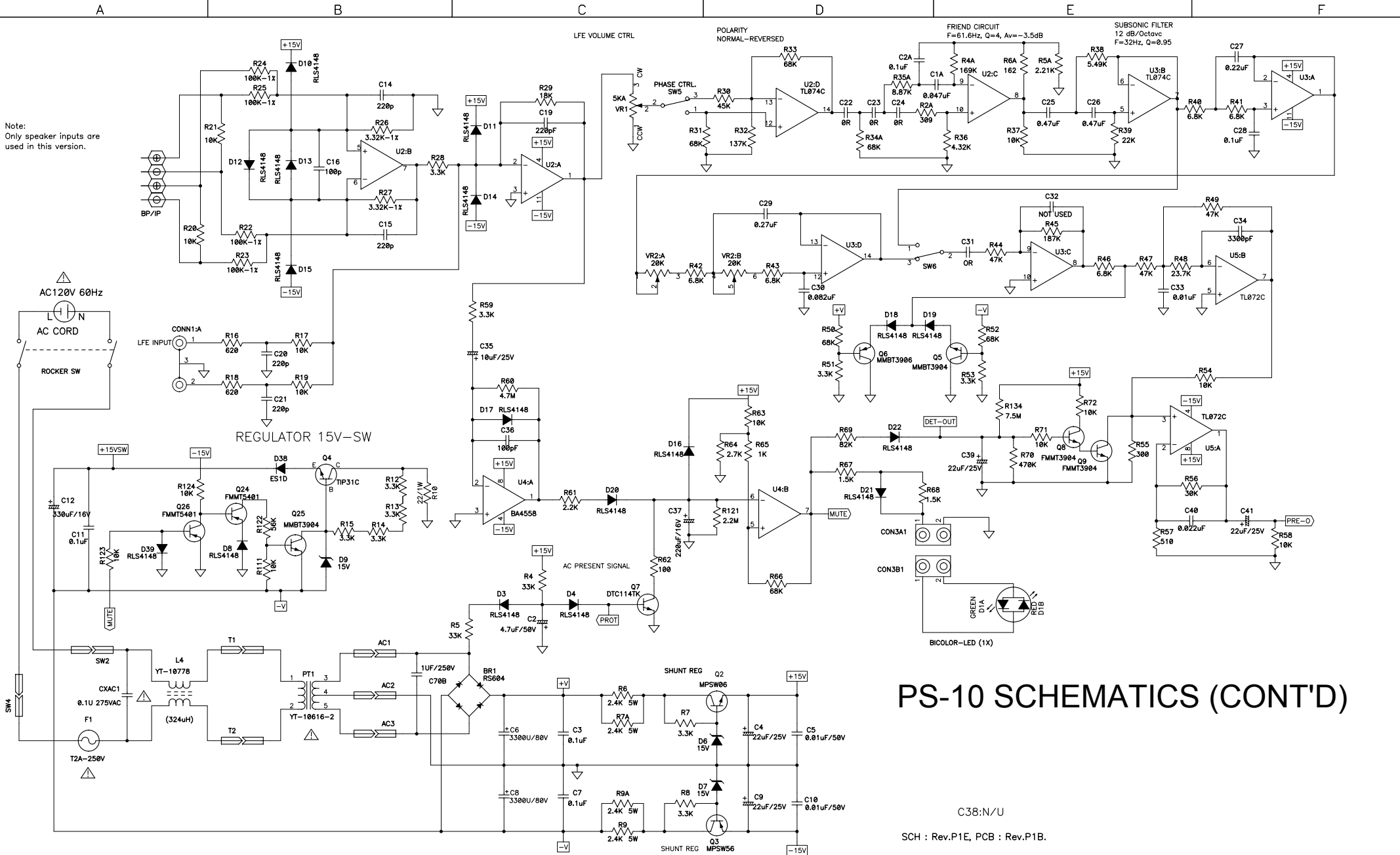

# PS-10 SCHEMATICS (CONT'D)

C38:N/U  
SCH : Rev.P1E, PCB : Rev.P1B.

Rev: P1A	Notes: SUB DESIGN ORIGINATED FROM PB12	Date: 2003/03/18	Rev:	Notes:	Date:	Draw by	Designed by	Checked by	Approved By	Customer: INFINITY
										P/N: 416-0321105
										Model no: PS-10/120V
										Sch name: PRE AMP PCB
										Issue no: ET-01-21-4256
										Date: 2003/05/20
										Sheet: 13 Rev: 01
										Size: A2 Author: VITA

音律電子股份有限公司  
ELYTONE ELECTRONIC CO.,LTD.  
TEL:+886-2-2671-2071  
FAX:+886-2-2672-5943

PS-12 SCHEMATICS

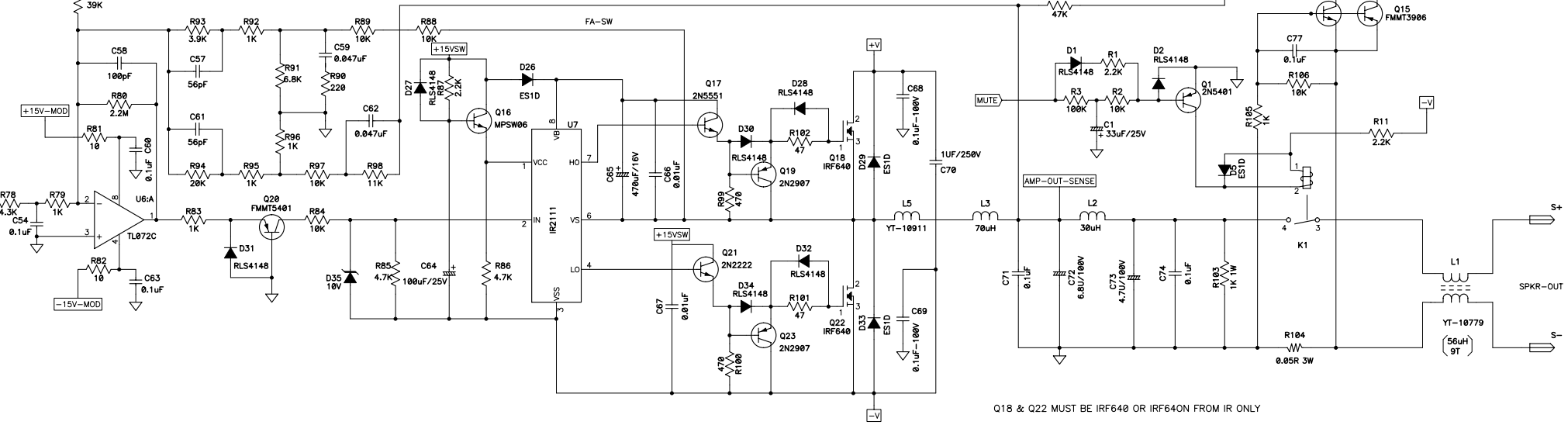
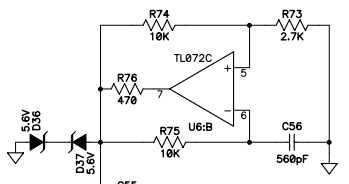
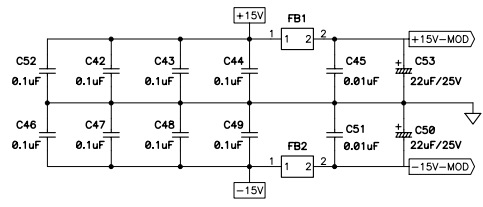

Q18 & Q22 MUST BE IRF640 OR IRF640N FROM IR ONLY

SCH : Rev.P1E, PCB : Rev.P1B.

351648-001

Rev:	Notes:	Date:	Rev:	Notes:	Date:	Draw by	Designed by	Checked by	Approved By	Customer:	HARMAN
P1A	SUB DESIGN ORIGINATED FROM PB12 AMP	2003/03/18								P/N:	416-0321103
										Model no:	PS-12/120V
										Sch name:	POWER AMP PCB
										Issue no:	ET-01-21-4258
										Date:	2003/05/20
										Sheet:	13 Rev: P1A
										Size:	A2 Author: VITA

音律電子股份有限公司  
 ELYTONE ELECTRONIC CO.,LTD.  
 TEL:+886-2-2671-2071  
 FAX:+886-2-2672-5943



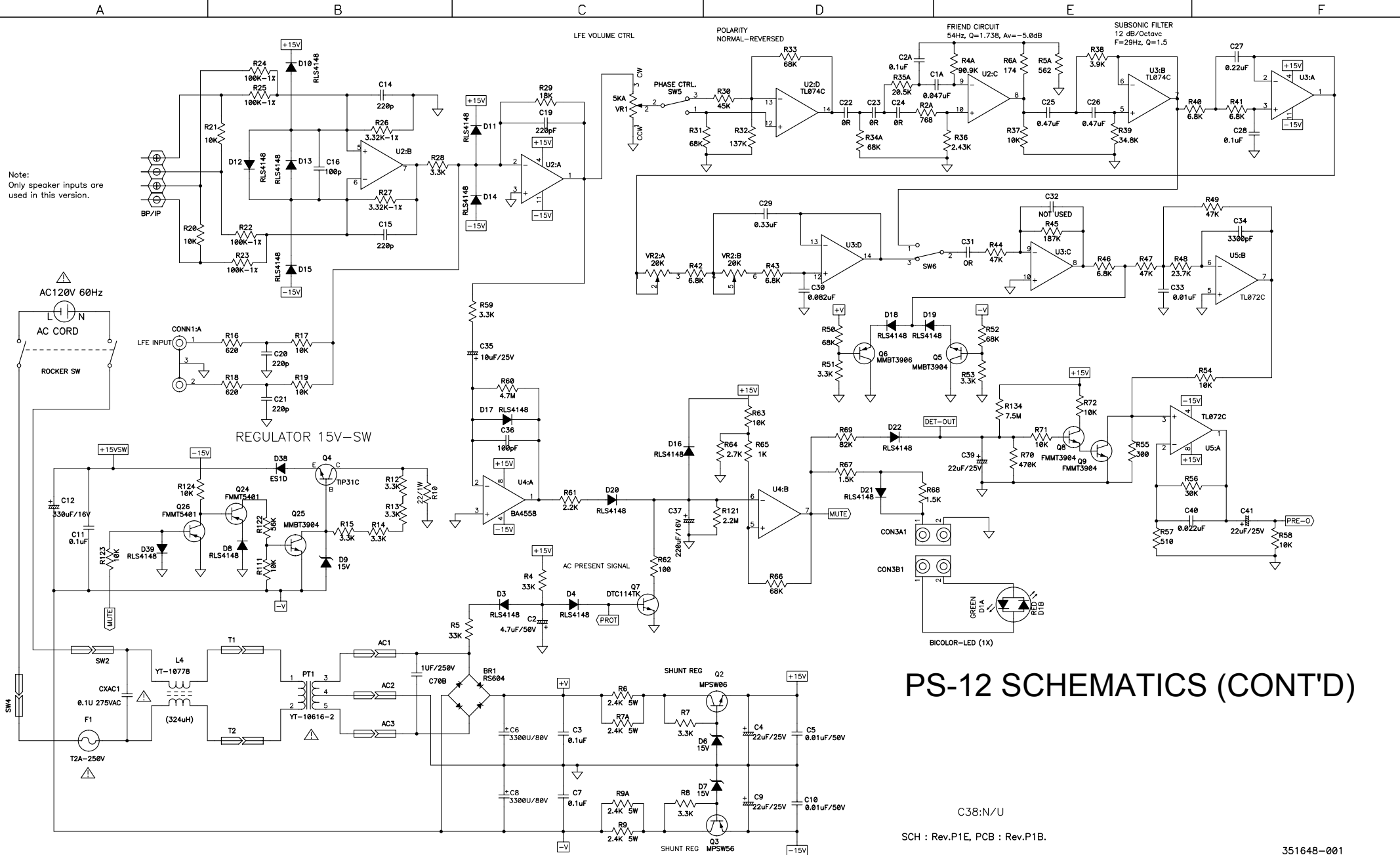

# PS-12 SCHEMATICS (CONT'D)

C38:N/U

SCH : Rev.P1E, PCB : Rev.P1B.

351648-001

Rev:	Notes:	Date:	Rev:	Notes:	Date:	Draw by	Designed by	Checked by	Approved By	Customer:
P1A	SUB DESIGN	2003/03/18								HARMAN
										P/N: 416-0321103
										Model no: PS-12/120V
										Sch name: PRE AMP PCB
										Issue no: ET-01-21-4258
										Date: 2003/05/20
										Sheet: 12 Rev: P1A
										Size: A2 Author: VITA

音律電子股份有限公司  
ELYTONE ELECTRONIC CO.,LTD.  
TEL:+886-2-2671-2071  
FAX:+886-2-2672-5943