

Integra® SERVICE MANUAL

DVD CHANGER DPC-6



Black model 120V AC, 60Hz

SAFETY-RELATED COMPONENT WARNING!!



COMPONENTS IDENTIFIED BY MARK  ON THE SCHEMATIC DIAGRAM AND IN THE PARTS LIST ARE CRITICAL FOR RISK OF FIRE AND ELECTRIC SHOCK. REPLACE THESE COMPONENTS WITH ONKYO PARTS WHOSE PART NUMBERS APPEAR AS SHOWN IN THIS MANUAL.

MAKE LEAKAGE-CURRENT OR RESISTANCE MEASUREMENTS TO DETERMINE THAT EXPOSED PARTS ARE ACCEPTABLY INSULATED FROM THE SUPPLY CIRCUIT BEFORE RETURNING THE APPLIANCE TO THE CUSTOMER.

TABLE OF CONTENTS

Operating instructions Safety precautions-----	2
Specifications-----	3
Front panel/ Rear panel views-----	4
DVD display/ Remote controller views-----	5
Block diagram-----	6
Parts replacement and adjustment procedure-----	7-17
Replacement of optical pickup-----	18
Exploded view-----	19-20
Exploded parts list-----	21
Exploded view (Roulette mecha.)-----	22
Exploded view (Mechanism)-----	23
Roulette mechanism parts list-----	24
Location of mechanism parts-----	25-26
Electric parts list-----	27-28, 37
Schematic diagram-----	29-36
Printed circuit board view(Roulette mecha.)-----	38
Microprocessor terminal description-----	39-40
IC Block diagram-----	41-42
Trouble shooting-----	43-50
Printed circuit board view-----	51-56
PC board connection diagram-----	57-58
Main PC board view-----	59-62
DVD mechanism/ Main PC board parts list-----	63-64
Upgrade firmware-----	65-66
Memo-----	67
Packing view-----	68

OPERATING INSTRUCTIONS SAFETY PRECAUTIONS

	WARNING RISK OF ELECTRIV SHOCK DO NOT OPEN	
AVIS	RISQUE DE CHOC ELECTRIQUE NE PAS OUVRIR	
WARNING : TO REDUCE THE RISK OF ELECTRIC SHOCK, DO NOT REMOVE COVER (OR BACK). NO USERSERVICEABLE PART INSIDE, REFER SERVICING TO QUALIFIED SERVICE PERSONNEL.		

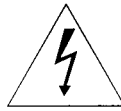

The lightning flash with arrowhead symbol, within an equilateral triangle, is intended to alert the user to the presence of uninsulated "dangerous voltage" within the product's enclosure that may be of sufficient magnitude to constitute a risk of electric shock to persons.



The exclamation point within an equilateral triangle is intended to alert the user to the presence of important operating and maintenance (servicing) instruction in the literature accompanying the appliance.

WARNING : TO REDUCE THE RISK OF FIRE OR ELECTRIC SHOCK, DO NOT EXPOSE THIS APPLIANCE TO RAIN OR MOISTURE. DANGEROUS HIGH VOLTAGES ARE PRESENT INSIDE THE ENCLOSURE. DO NOT OPEN THE CABINET. REFER SERVICING TO QUALIFIED PERSONNEL ONLY.

CAUTION : TO PREVENT ELECTRIC SHOCK, MATCH WIDE BLADE OF PLUG TO WIDE SLOT, FULLY INSERT.

ATTENTION : POUR EVITER LES CHOCS ELECTRIQUE, INTRODUIRE LA LAME LA PLUS LARGE DA LA FICHE DANS LA BORNE CORRESPONDANTE DA LA PRISE ET POUSSER JUSQU' AU FOND.

PRECAUTIONS

Replacing the fuses

For continued protection against risk fire, replace only with same type and same rating fuse.

CIRCUIT No.	PART No.	DESCRIPTION
F901	252157	1.25A-UL/T-237

 This symbol located near the fuse indicates that the fuse used is fast operating type. For continued protection against fire hazard, replace with same type fuse. For fuse rating refer to the marking adjacent to the symbol.

 Ce symbole indique que le fusible utilise est a rapide. Pour une protection permanente, n'utiliser que des fusibles de meme type. Ce darmier est indique la qu le present symbol est appose.

LASER BEAM CAUTION LABEL

 <p>WAVE LENGTH: 650nm LASER POWER: 5mW 波 長 : 650nm 激光功率 : 5mW 90763400</p>	<p>CAUTION -VISIBLE LASER RADIATION WHEN OPEN AND INTERLOCK DEFEATED. DO NOT STARE INTO BEAM.</p> <p>ADVARSEL -LASERSTRÅLING VED ÅPNING NÅR SPERRMEKANISME/REKKE AV FUNKTION SE IKKE PÅ I STRÅLEN.</p> <p>ADVARSEL -LASERSTRÅLING NÅR DEKSEL ÅPNET OG SPERRMEKANISME/REKKE SEES IKKE PÅ I STRÅLEN.</p> <p>VARNING -OBSYNT LASERSTRÅLING NÅR DENNA DEL ÄR ÖPPNAD OCH SPÄRRMEKANISME/REKKE SEES IKKE PÅ I STRÅLEN.</p> <p>VARNING -AVTÄTTASER JA SUOJALUKITUS OIRELLIÄSSÄ KÄYTTÄÄ LASER-SÄTELYÄ. ÄLÄ TÄKOTÄ SÄTELYÄ.</p> <p>注意 -レーザー光線はカバーを開けたとき、遮光機構が正常に動作しない場合に発生する可能性があります。直射光線に目を近づけないでください。</p>
---	--

When the power supply is being turned on, you may not remove this laser cautions label, radiation of a laser may be received. Pickup Head consists of a laser diode that is very susceptible to external static electricity. Although it operates properly after replacement, if it was subject to electrostatic discharge during replacement, its life might be shortened. When replacing, use a conductive mat, soldering iron with ground wire, etc. to protect the laser diode from damage by static electricity. And also, the LSI and IC are same as above.

SPECIFICATIONS

DVD Changer

Power supply	AC 120 V, 60 Hz
Power consumption	19 W
Weight	6.9 kg
External dimensions	435 x 131 x 433 mm (W/H/D)
Signal system	Standard NTSC
Laser	Semiconductor laser ,wavelength 650 nm
Frequency range (digital audio)	DVD linear sound : 48 kHz sampling 4 Hz to 22 kHz 96 kHz sampling 4 Hz to 44 kHz Audio CD : 4 Hz to 20 kHz
Signal-to-noise ratio (digital audio)	More than 96 dB (EIAJ)
Audio dynamic range (digital audio)	More than 90 dB (EIAJ)
Harmonic distortion (digital audio)	Less than 0.01 %
Wow and flutter	Below measurable level (less than ± 0.001 % (W .PEAK)) (EIAJ)
Operating conditions	Temperature: 5°C to 35°C (41 to 95 degrees), Operation status: Horizontal

Outputs

Video output	1.0 V (p-p), 75 Ω , negative sync., pin jack x 1
S video output	(Y) 1.0 V (p-p), 75 Ω , negative sync., Mini DIN 4-pin x 1 (C) 0.286 V (p-p), 75 Ω
Digital Audio output (optical)	Optical connector x 1
Digital Audio output (coaxial)	0.5 V (p-p), 75 Ω , pin jack x 1
Audio output (analog audio)	2.0 V (rms), 470 Ω , pin jack (L, R) x 1

* Design and specifications are subject to change without notice.

BLOCK DIAGRAM

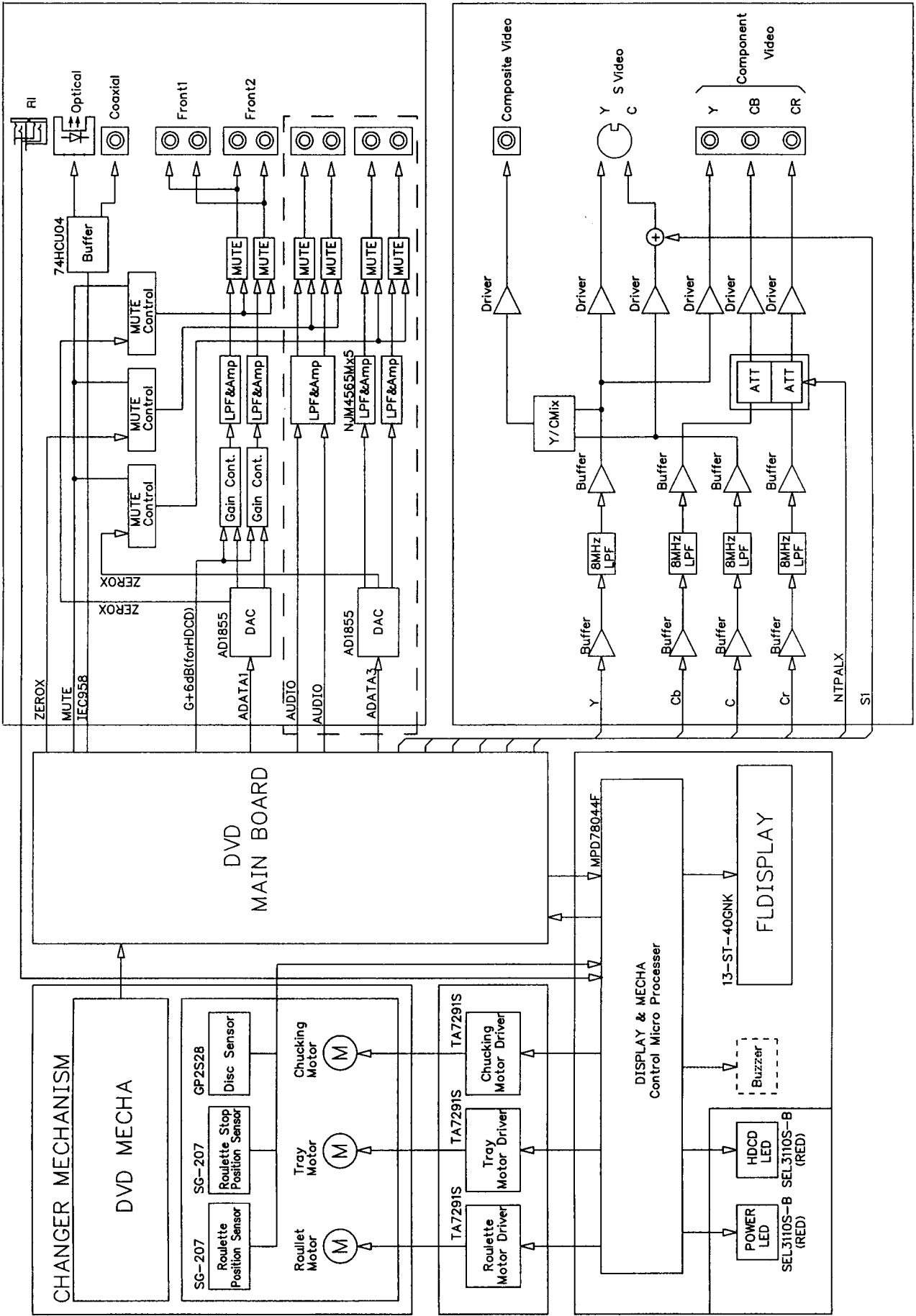

1. REPLACEMENT OF MECHANICAL PARTS

1-1. Cabinet Replacement

1-1-1. Top Cover

1. Remove 7 screws (1) and remove the top cover (2).

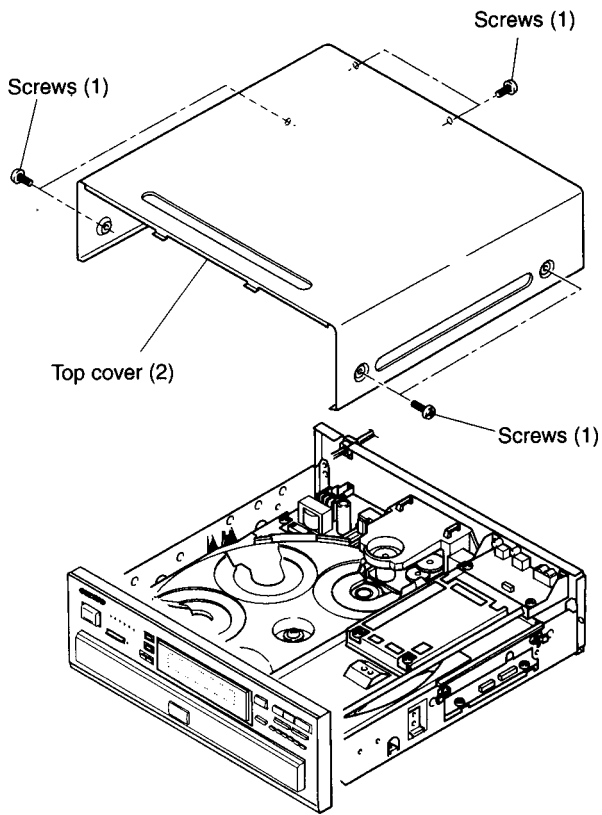

Fig. 2-1-1

1-1-2. Tray Panel

1. Eject the tray (1).
2. Twist the tray panel (2) a little in the arrow A direction with the tray (1) held to release two claws and lift up the tray panel (2) in the arrow B direction, then the tray panel (2) is removed.
3. When mounting the tray panel (2), insert the tray panel (2) along the groove of the both sides of the tray (1) until it clicks.

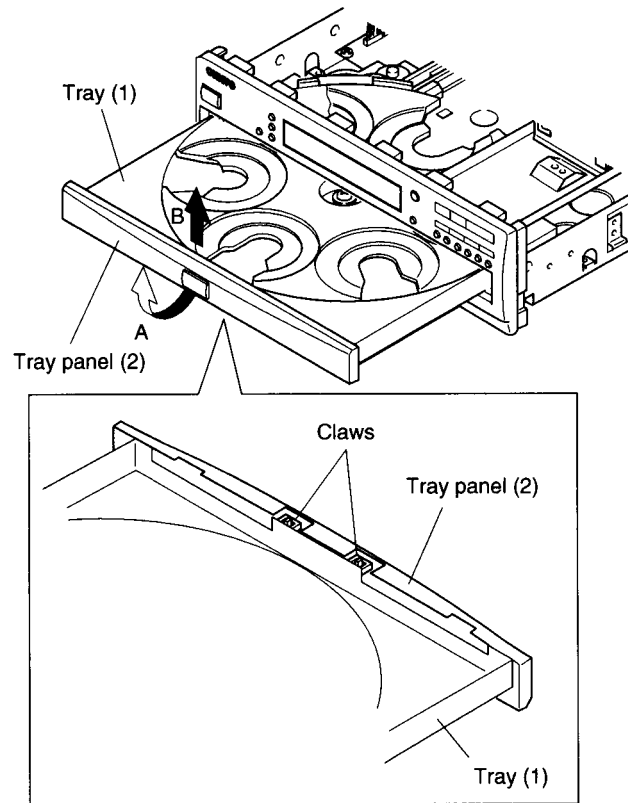

Fig. 2-1-2

1-1-3. Front Panel

1. Remove three screws(4) of the aluminum front panel.
2. Pull out the tray and remove the tray panel.
(Refer to item Fig.2-1-2)
3. Remove three screws(6) of the front bracket.
4. Peel off the tape(1) and disconnect the FFC(2).
5. Disconnect the FFC(3).
6. Remove the bosses of the front panel(9).

NOTE:

- When connecting the FFC(2), be sure to insert it to the connector after passing through the FFC band.

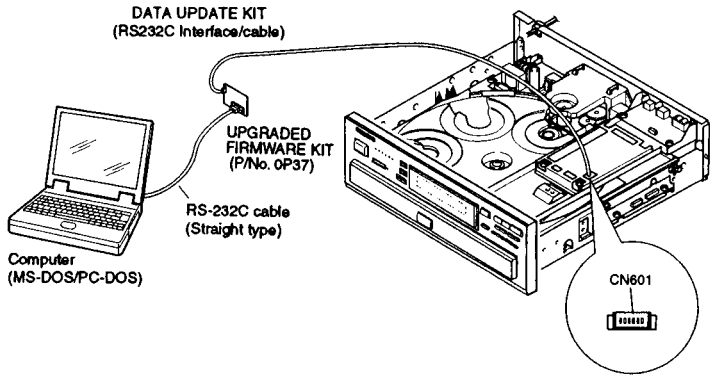

Fig. 2-1-3

1-2. PC Board Replacement

1-2-1. Main PC Board

1. Peel off the tape(1).
2. Disconnect five FFCs(4) and one connector(3).

Note:

Before disconnecting the FFC from the main PC board, pull out the round bottom cover (attached with both-side adhesive tape) and be sure to short-circuit the LD-SHORT J019 by a clip or soldering.

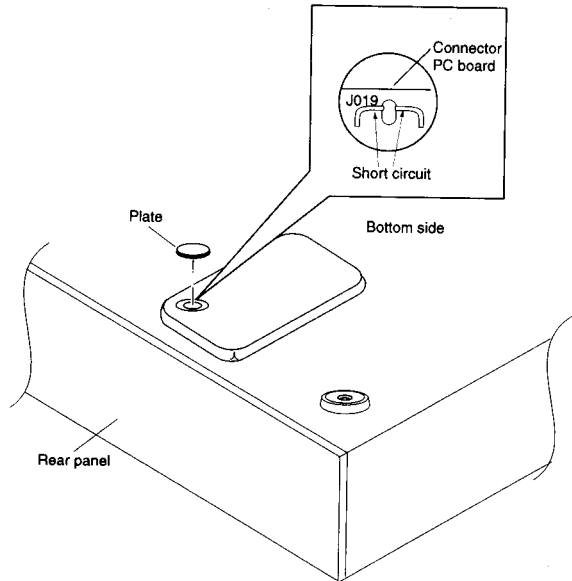

Fig. 2-1-5

1-1-4. Rear panel

1. Remove the AC cord bushing(1).
2. Remove the 17 screws(2) and remove the rear panel(3).

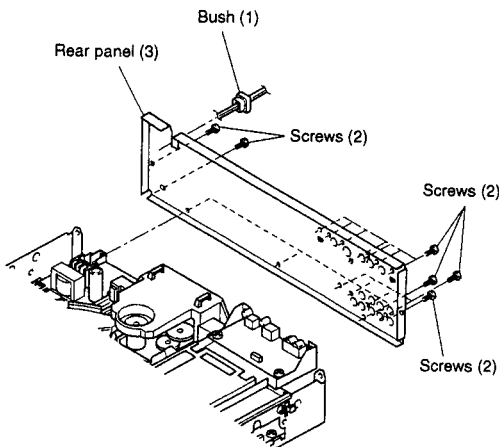

Fig. 2-1-4

1-2-2. Video Output PC Board

1. Disconnect one FFC (1) and one connector (2).
2. Remove two screws (3).
3. Remove four screws (4) and remove the video output PC board (5).

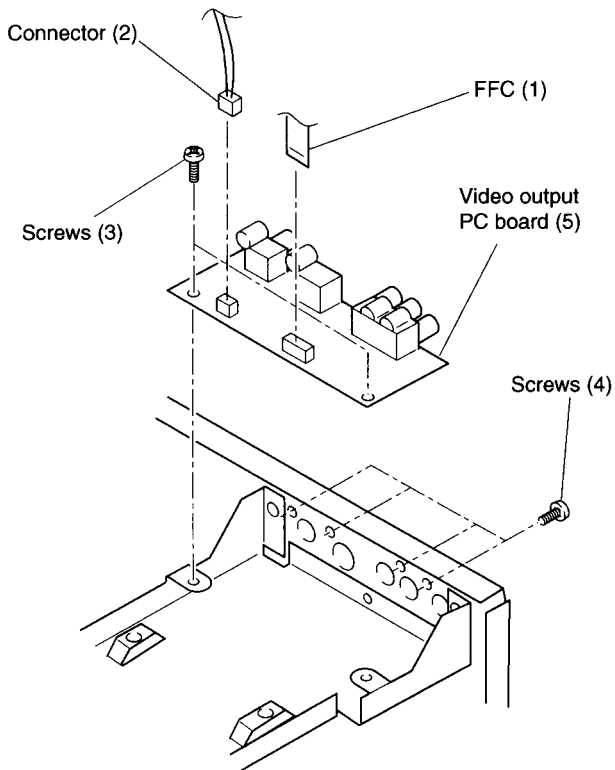

Fig. 2-1-6

1-2-3. Mechanism Drive/Audio Output PC Board

1. Peel off the tape (1).
2. Disconnect five FFCs (2) and two connectors (3).
3. Remove seven screws (6) and remove the stay (7).
4. Pull out the tray (8) to this side until it stops.
5. Disconnect two FFCs (9) and three connectors (10).
6. Remove four screws (11) and four screws (12) and remove mechanism drive/audio output PC board (13).

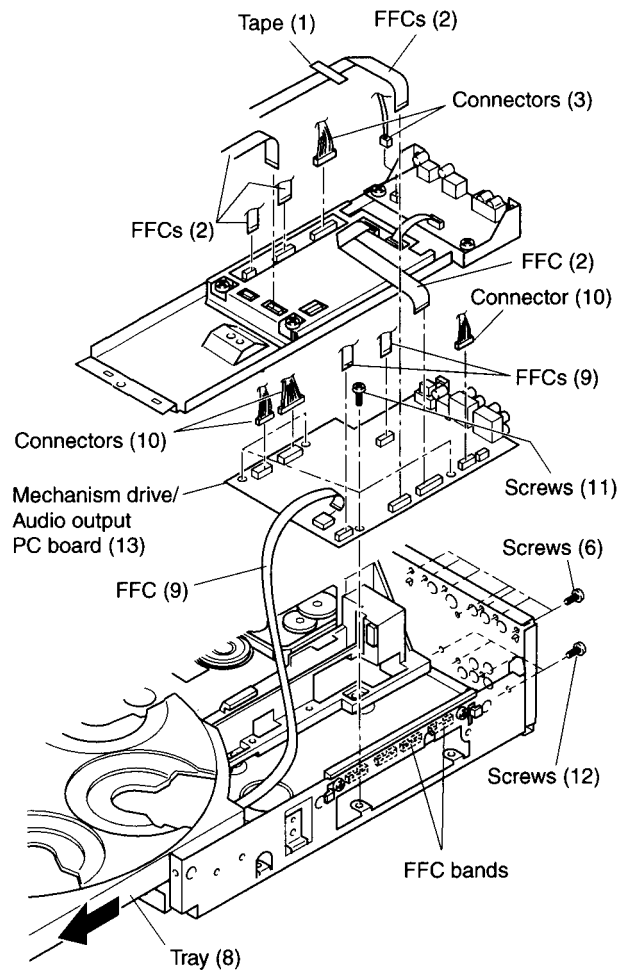

Fig. 2-1-7

1-2-4. Power Supply PC Board

1. Pull out the tray to this side until it stops.
2. Remove one screw (1).
3. Disconnect one connector (2).
4. Remove the PC board clip (3) and remove the power supply PC board (4) by lifting upward.

(The power supply PC board (4) is connected to the DC power PC board (5) with the connector (6).)

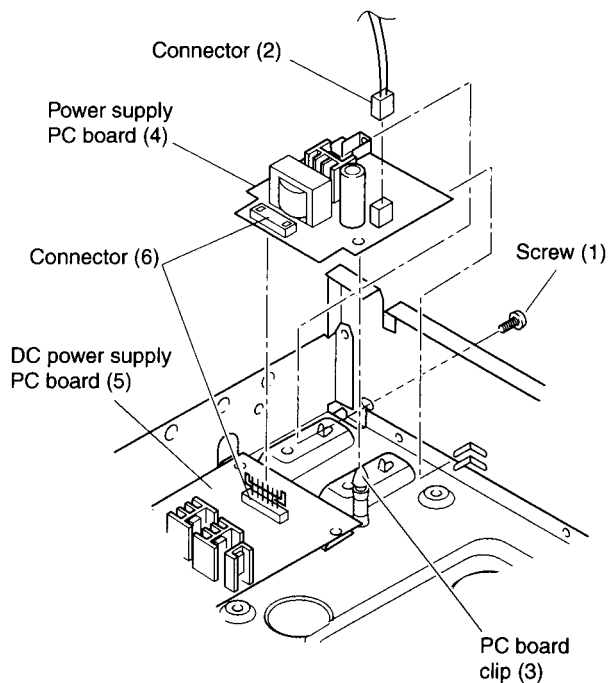

Fig. 2-1-8

1-2-5. DC Power Supply PC Board

1. Remove the power supply PC board.
 2. Cut off three cord bands (1).
 3. Remove four screws (2) and remove the DC power supply PC board (3).
- (Refer to Figure A when mounting the cord band (1).)

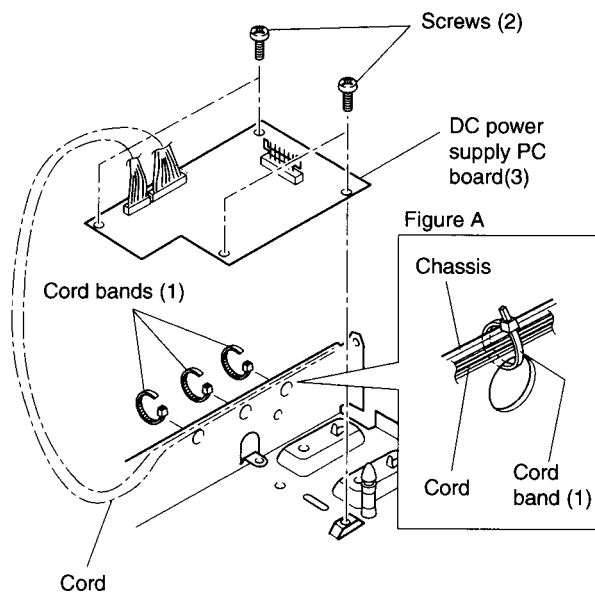

Fig. 2-1-9

1-2-6. Front PC Board and Power Switch PC Board

1. Remove the front panel.
2. Remove six screws (1), and remove the metal plate (2) and the front PC board (3).
3. Remove three screws (4) and remove the power switch PC board (5).

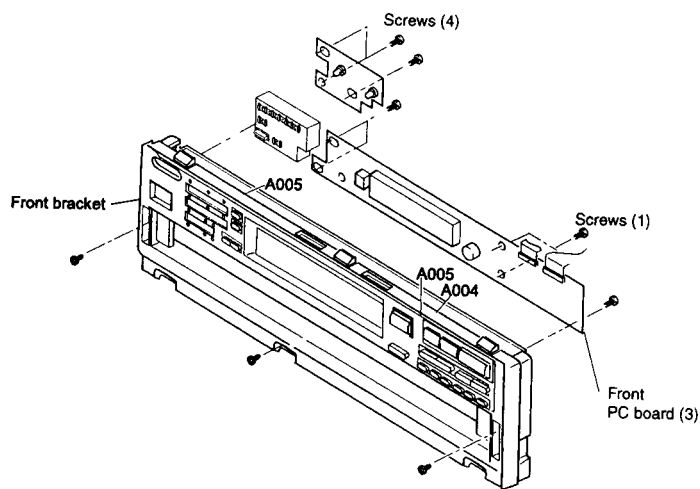

Fig. 2-1-10

1-3. Tray Replacement

1-3-1. Tray

1. Remove the front panel. (Refer to item 1-1-3.)
2. Pull out the tray (1) until it stops.
3. Disconnect one FFC (2).
4. Push the claw and pull out the tray to this side.

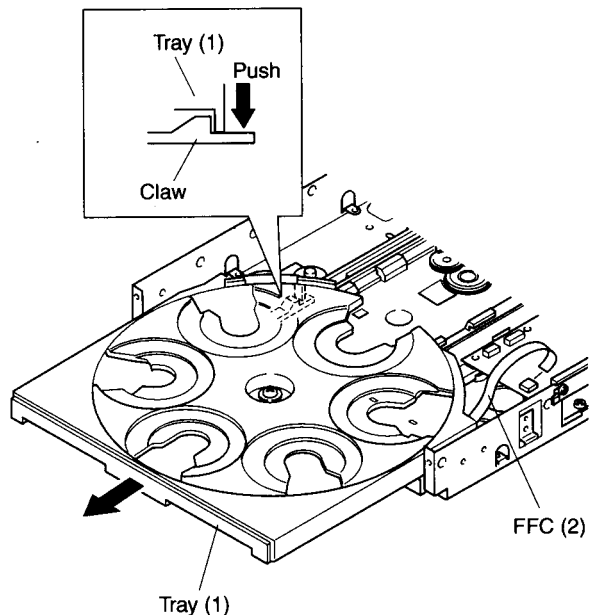

Fig. 2-1-11

1-3-2. Roulette

1. Remove the tray. (Refer to item 1-3-1.)
2. Remove one screw (1) and remove the roulette (2).

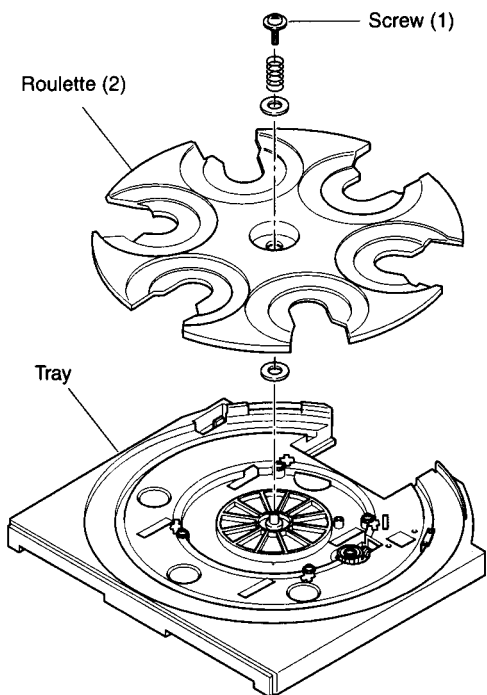

Fig. 2-1-12

1-3-3. Wheel Gear, Worm Gear, Disc Sensor PC Board, Position Sensor PC Board, Loading Motor

1. Remove the tray roulette. (Refer to item 1-3-2.)
2. Remove one screw (1) and remove the wheel gear (2).

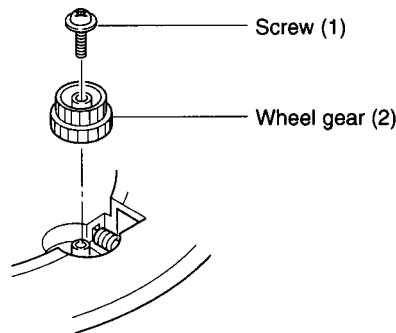

Fig. 2-1-13

3. Turn over the tray.
4. Remove one screw (3), and remove the worm gear (4), pin (5), and belt (6).
5. Remove one screw (7) and remove the disc sensor PC board (8).
6. Remove two screws (9) and remove the motor cover (10).
7. Remove one screw (11) and release three claws, and remove the position sensor PC board (12).
8. Desolder and remove the loading motor (13).

Note:

- Be sure to pass the cords through the cord clamps when wiring.

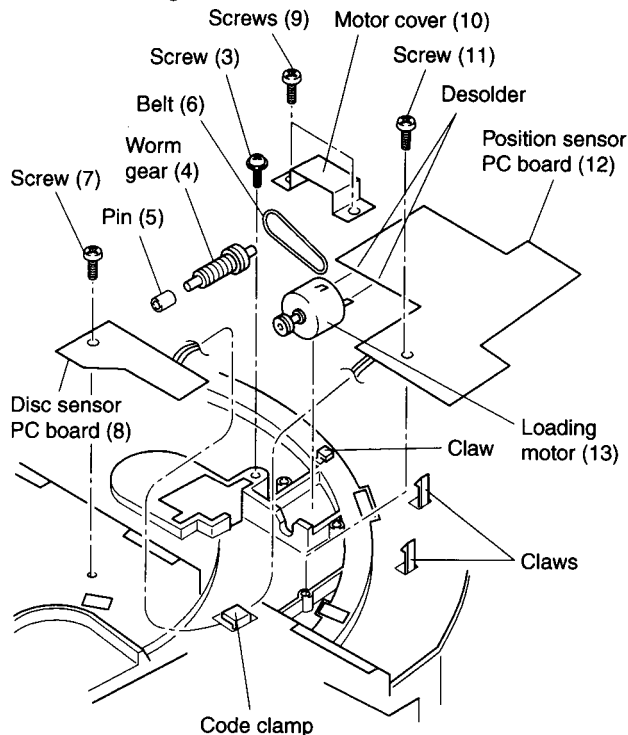

Fig. 2-1-14

1-4. Mechanism Parts Replacement

1-4-1. Mechanism Chassis Assembly

1. Remove the tray.
2. Remove two cords (2) from the cord clamps (1).
3. Disconnect one FFC (4) and two connectors (5).
4. Remove seven screws (6).
5. Remove two screws (7) and remove the mechanism chassis assembly (8).

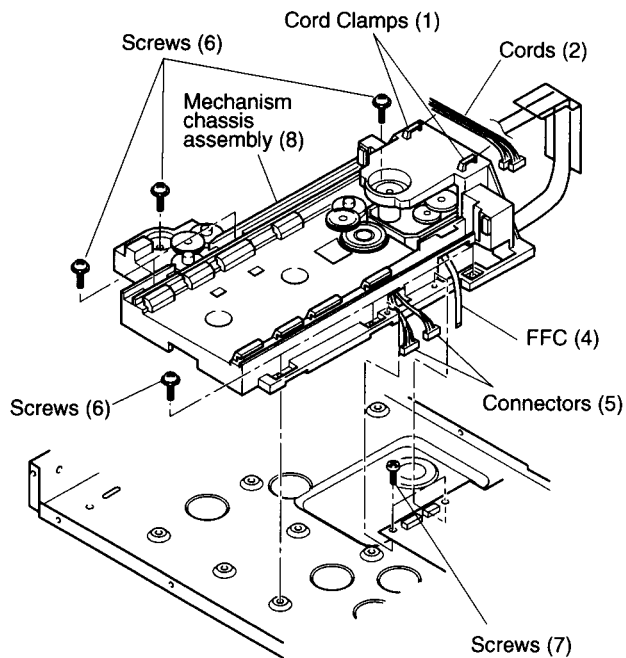

Fig. 2-1-15

1-4-2. Sub Chassis Assembly

1. Remove the mechanism chassis assembly.
2. Turn over the mechanism chassis assembly.
3. Remove one screw (1) and remove the sub chassis assembly (2).

Note:

- When mounting, tighten the screw (1) after fitting the boss with the cam groove.

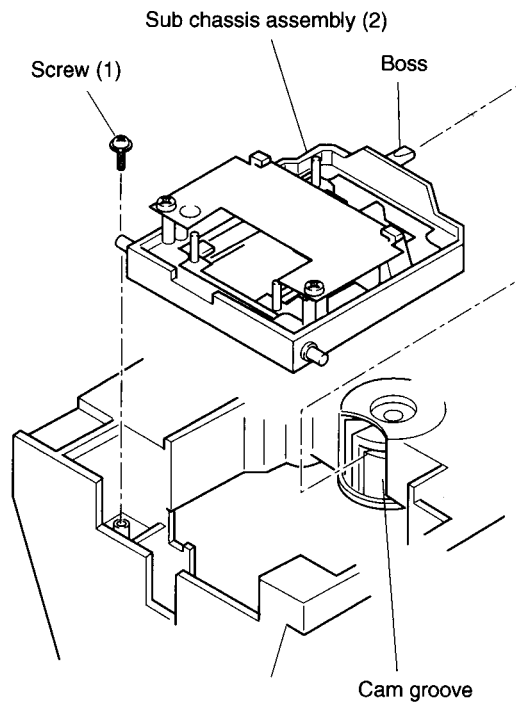

Fig. 2-1-16

1-4-3. LD Short PC Board

1. Remove the sub chassis assembly.
2. Remove two screws (1) and remove the LD short PC board (2).

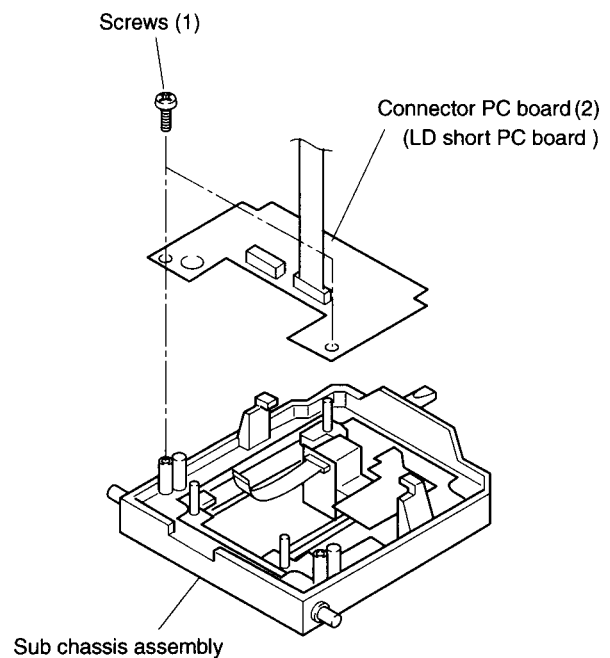

Fig. 2-1-17

1-4-4. Pickup Mechanism Assembly

1. Remove the sub chassis assembly.
2. Disconnect the FFC (1).
3. Remove four screws (2) and remove the pickup mechanism assembly. (3).

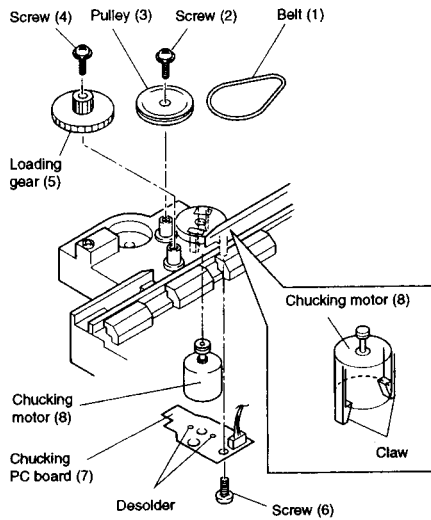

Fig. 2-1-18

Note:

The dampers' color differs when used for the front side and the rear.

when mounting the pickup mechanism assembly (3) with the screws (1), push the pickup mechanism assembly (3) downward without being caught and tighten the screws (1) after placing the washer with the damper bent.

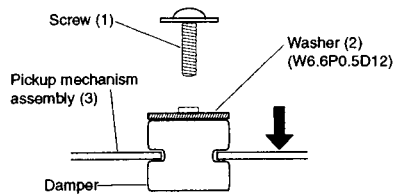

Fig. 2-1-19

1-4-5. Gear B Assembly, Gear A and Rack Gear

Assembly

<Removal>

1. Release one claw and remove the gear B assembly (1).
2. Remove the gear A (2).
3. Remove one screw (3) and remove the rack gear assembly (4).

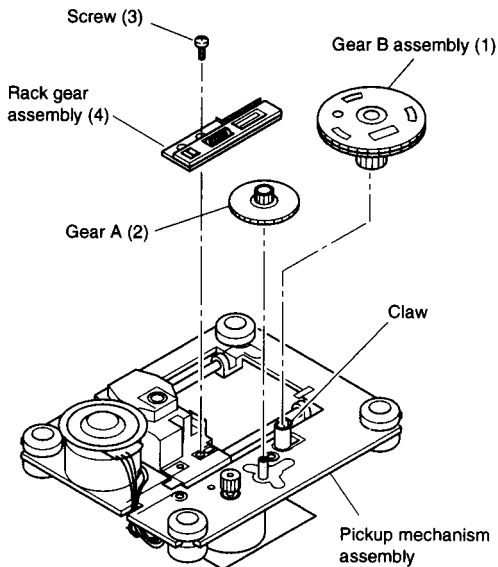

Fig. 2-1-20

<Mounting>

1. When mounting, perform the reverse order of the removal.
2. Mount the gear B assembly (1) by pushing the pickup head (5) to the disc motor side (arrow A direction) and shifting the upper gear of the rack gear assembly (4) in the arrow B direction. (Refer to Fig.2-1-22)
3. Fit the positioning holes on the upper gear and lower gear of the gear B assembly (1) and mount on the pickup mechanism assembly with the phase matched. At this time, note that the phase of the gear B assembly (1) and the gear A (2) show's the status in the Fig.2-1-23.

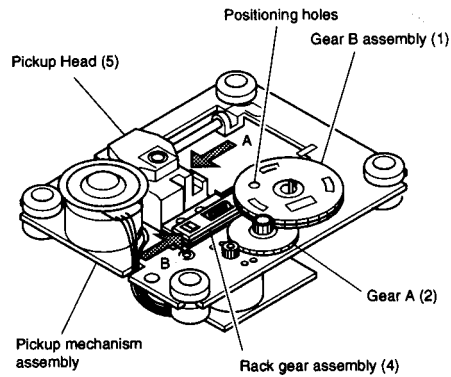

Fig. 2-1-21

Note:

- Mount the gear B assembly (1) and the gear a (2) with their gear teeth placed more than on tooth at least inside the shaded portion.

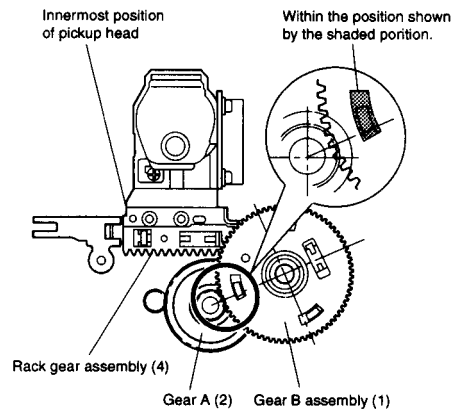

Fig. 2-1-22

1-4-6. Feed Motor

<Removal>

1. Remove the gear B assembly (1) and the gear A (2).
2. Remove two screws (1) and remove the feed motor (2) (with the feed motor PC board (3) attached.)
3. Desolder the terminals of the feed motor (2) and remove the feed motor PC board (3).

<Mounting>

1. Tighten the feed motor (2) on the pickup mechanism assembly with two screws (1).
2. Insert the feed motor PC board (3) with the positioning pin on the chassis matched and solder the terminals.
3. Perform the reverse order of the removal.

Note:

- After mounting, put the lead wires through the notch of the pickup mechanism assembly.
- When replacing the loading motor, meet the polarity phase of the terminals.

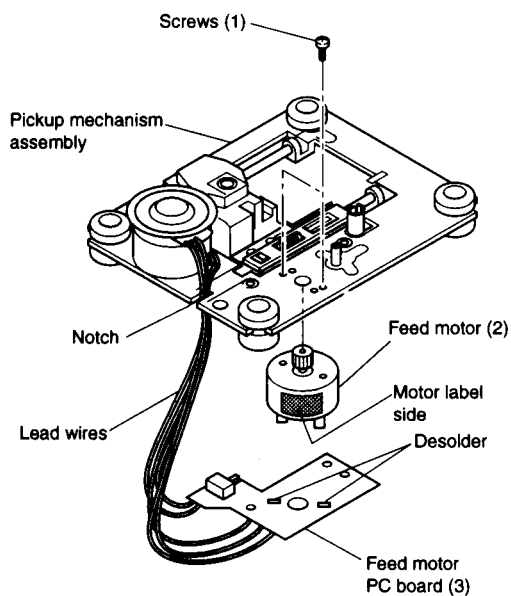

Fig. 2-1-23

1-4-7. Chucking Motor

1. Remove the mechanism chassis assembly.
2. remove the belt (1).
3. Remove one screw (2) and remove the pulley (3).
4. Remove one screw (4) and remove the loading gear.
5. Turn over the mechanism chassis assembly.
6. remove one screw (6).
7. De-solder and remove the chucking PC board (7).
8. Release two claws and remove the chucking motor (8).

Note:

When mounting, be sure to fix the cords with the cord clamps specified locations.

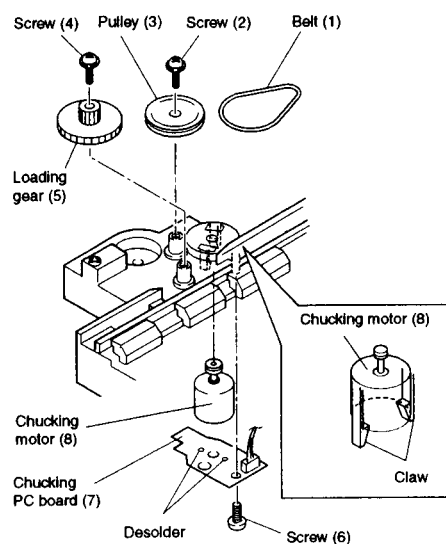

Fig. 2-1-24

1-4-8. Chucking sw PC Board

1. Remove the mechanism chassis assembly.
2. Turn over the mechanism chassis assembly.
3. Remove one screw (1) and remove the chucking SW PC board (2).

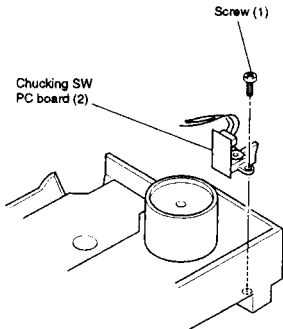

Fig. 2-1-25

1-4-9. Loading Motor PC Board

1. Remove the mechanism chassis assembly.
2. Remove the belt (1).
3. Remove one screw (2) and remove the pulley (3).
4. remove one screw (4) and remove the cam gear (5).
5. Turn over the mechanism chassis assembly.
6. Remove one screw (6).
7. De-solder and remove the loading motor PC board (7).
8. Release two claws and remove the loading motor (8).

Note:

The cam gear (5) is divided in upper and lower sides by releasing two claws.

When mounting, be sure fix the cords with the cord clamps at specified locations.

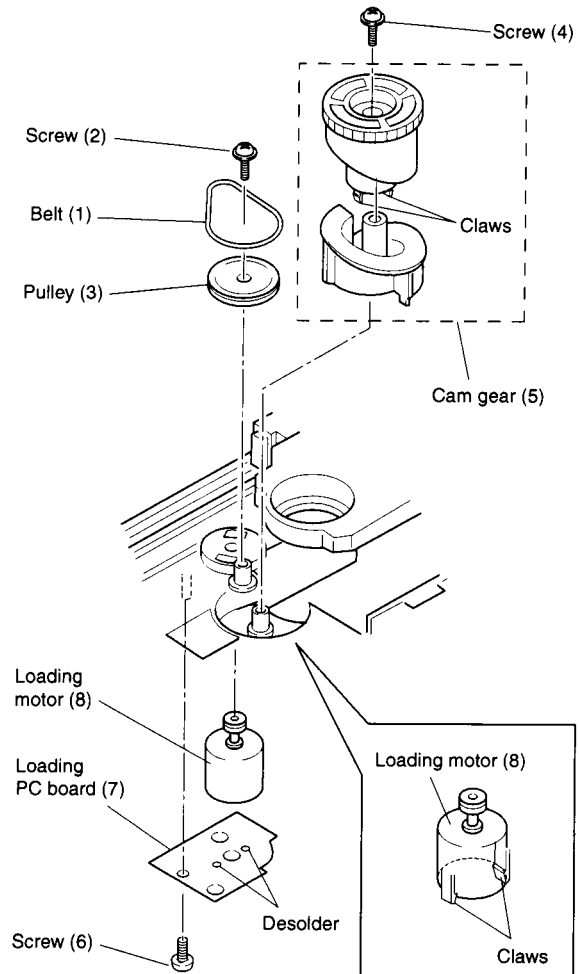

Fig. 2-1-26

1-4-10. Roulette IN/ OUT PC Board

1. Remove the tray rail.
2. Turn over the mechanism chassis assembly.
3. Remove one screw (1) and remove the roulette IN/ OUT PC board (2).

When mounting, be sure to fix the cords with the cord clamps at specified locations.

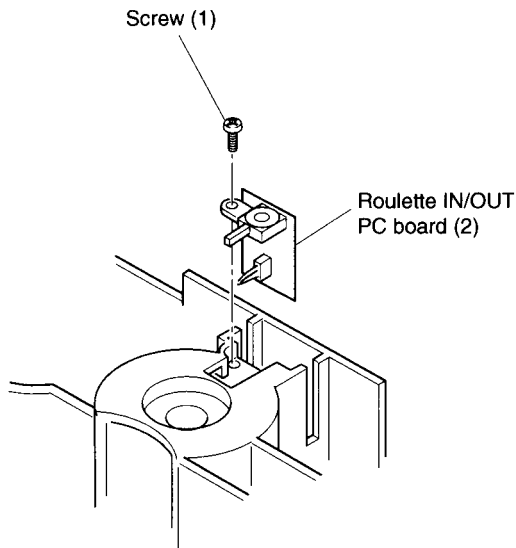

Fig. 2-1-27

1-4-11. Cord Wiring

Note:

- When removing the PC boards located on the bottom side of the mechanism chassis, switches, etc., wire the cords shown in the figure below and fix with the cord clamps

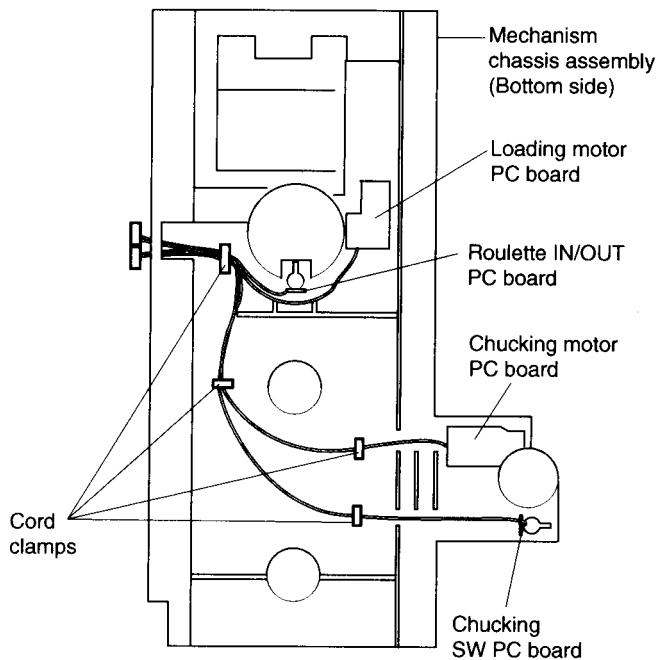

Fig. 2-1-28

REPLACEMENT OF OPTICAL PICKUP

The laser diode in the optical pickup block is so sensitive to static electricity, surge current and etc. That the components are liable to be broken down or its reliability remarkably deteriorated. During repair, carefully take the following precautions.
Do not touch the optical pickup object lens with the hands.

1. Remove the spacer on bottom side of the chassis. (Fig. A)
When replacing the optical pick up, first short J019 on Connector PC board(NAAR-3397).
2. Solder the LD terminal on the DVD mechanism.
(Fig. B)
3. Disconnect the flexible flat cable E101 and E103..
4. Replace the optical pickup.
5. Connect the flexible flat cable E101 and E103.
6. Unsolder the LD terminal on Mechanism.
(Fig. C)
7. Cutting the J019.

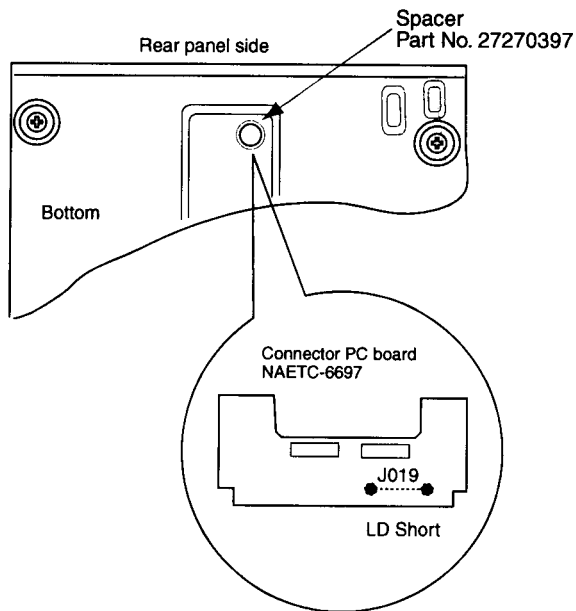

Fig. A

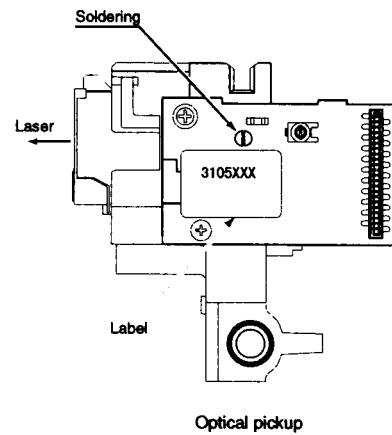

Fig. B

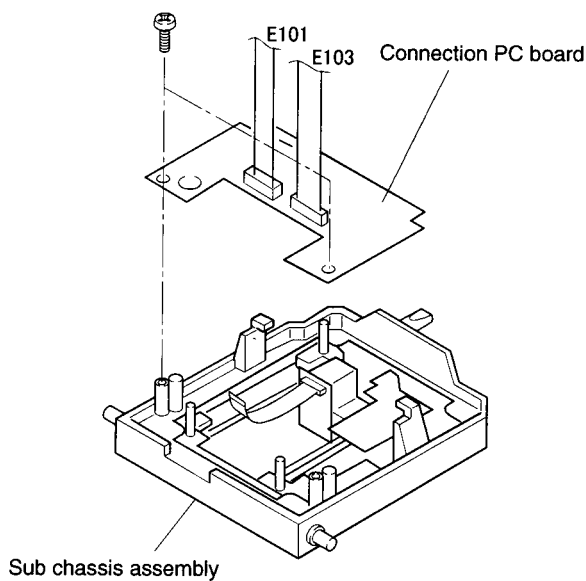
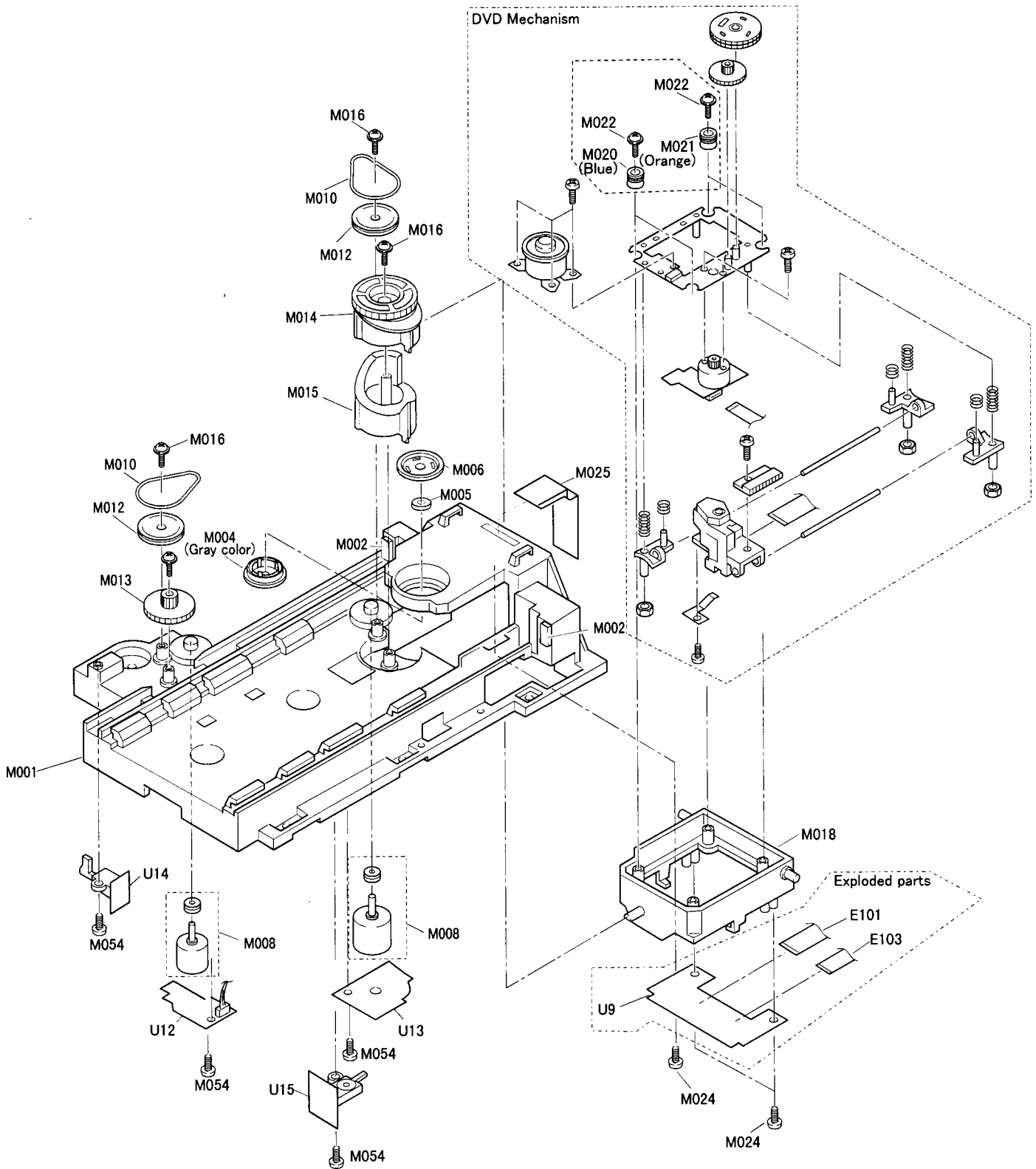

Fig. C

PARTS LIST

REF.NO. PART NO.	DESCRIPTION	REF.NO. PART NO.	DESCRIPTION
A001 27111129A	Front bracket	E101 2042180512	NCFC2-180512, Flexible flat cable
A002 27141746	Retainer F	E103 2042183512	NCFC2-183512, Flexible flat cable
A003 838130088	3TTB+8B, Self-tapping screw	E104 2042080812	NCFC2-080812, Flexible flat cable
A004 29110138	Tape,Copper	E105 2045082012	NCFC5-082012, Flexible flat cable
A005 28141400	Cushion	E106 2046072022	NCFC6-072022, Flexible flat cable
A006 27100327B	Chassis	E201 2045130512	NCFC5-130512, Flexible flat cable
A007 28175252B	Isolated plate	E202 2044180122	NCFC4-180122, Flexible flat cable
A008 27190511	KGLS-16RF, Holder	E701 2045132512	NCFC5-132512, Flexible flat cable
A010 27191089	WLS-10-0.,Holder	E702 2045194512	NCFC5-194512, Flexible flat cable
A011 27191084	Holder FFC	E711 27190608-1	Holder
A014 27130828	Bracket PC	E910 27301396	HL-28-0, Clamper
A015 27225143A	Shield case	F901 252157	△ 1.25A-UL/T-237, Fuse
A016 28141387	Cushion	U1 1H418589-2	NAAF-6689-2A, Output terminal PC board ass'y
A018 27191000	MFS-1000,Holder	U2 1H418590-2A	NAAF-6690-2A, Video amplifier PC board ass'y
A020 831430088	3TTW+8B(BC),Self-tapping screw	U3 1H418591-2A	NADIS-6691-2A,Display circuit PC board ass'y
A023 260208	Wire tie	U4 1H418592-2A	NADIS-6692-2A,LED indicator PC board ass'y
A024 29362584	Label	U5 1H418593-2A	NASW-6693-2A,Power switch PC board ass'y
A026 838430107	3TTB+10S(BC),Self-tapping screw	U6 1H418594-2A	NAETC-6694-2A,PC board ass'y
A051 27212131	Front panel	U7 1H418595-2A	NAPS-6695-2A,Power supply PC board ass'y(1)
A052 28135275	Badge	U8 1H418596-2A	NAPS-6696-2A,Power supply PC board ass'y(2)
A057 838440089	4TTB+8C(BC), Self-tapping screw	U9 1H418597-2A	NAETC-6697-2A,Connector PC board ass'y
A055 27122652	Rear panel	U10 24150011	SD-20D1,Main circuit PC board ass'y
A205 28198896	Facet 6	U11 1H418509-2A	NAPS-6709-2A,Inlet terminal PC board ass'y
A206 28198897	Facet 1		
A208 28191864	Clear plate		
A210 28148417A	Door		
A211 27262641	Plate DVD		
A213 28325465	Knob, POWER		
A214 28325686	Knob, ST		
A216 27175316B	Leg		
A217 28141332	Cushion for leg		
A220 28184680A	Top cover		
A221 838430088	3TTB+8B(BC), Self-tapping screw		
A607 27270397	Spacer		
A950 253295KAW	△ AS-UC-1#18, Power supply cord		

MECHANICAL EXPLODED VIEW (1)



MECHANICAL EXPLODED VIEW (2)

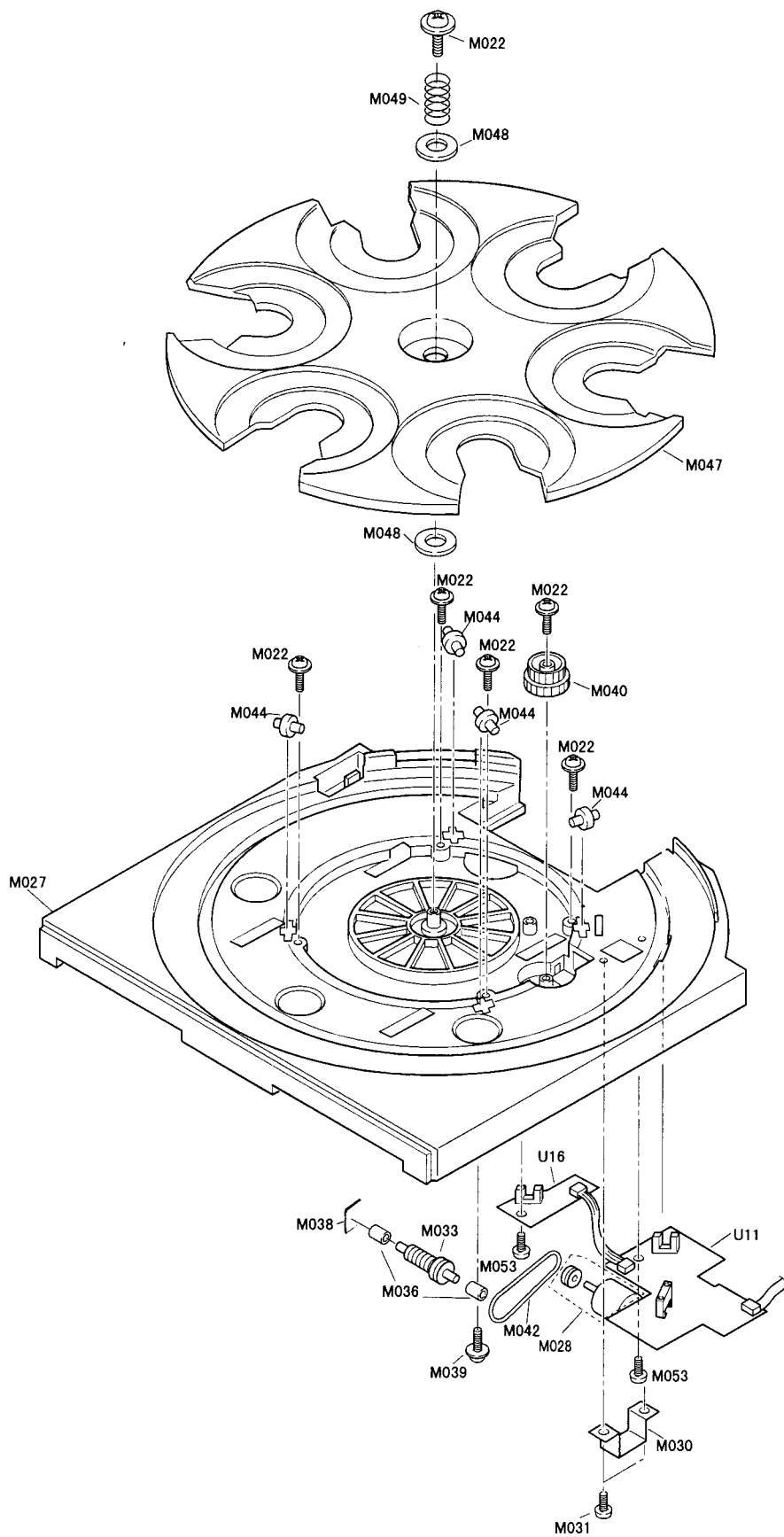

ROULETTE MECHANISM PARTS LIST

REF. NO.	PART NO.	DESCRIPTION	REF. NO.	PART NO.	DESCRIPTION
M001	24840109B	Rail	M036	24834017A	Spacer
M002	28141337Y	Cushion	M038	28141340Y	Cushion
M004	24824028	Cap CHD	M039	831430088	3TTW+8B(BC),Self-tapping screw
M005	24832028	Magnet CHC	M040	24810043Y	Gear, wheel
M006	24830028	Yoke CHC	M041	24840111	Special screw
M008	1H412901	RF-500TB-14415,Loading motor ass'y	M042	24816035	Rubber belt
M010	24816010AY	Rubber belt	M044	24840110Y	Roller
M012	24810040Y	Gear, pulley	M045	24840111	Special screw
M013	24810039A	Gear, load	M047	24840108A	Roulette
M014	24810041Y	Cam gear A	M048	24834016	Washer A
M015	24810042Y	Cam gear B	M049	24820033Y	Spring A
M016	831430088	3TTW+8B(BC),Self-tapping screw	M050	24840111	Special screw
M018	24802046A	Sub chassis	M053	838130088	3TTB+8B,Self-tapping screw
M019	24801003	SD-2109K1-ZX,DVD mechanism	M054	838426088	2.6TTB+8B(BC),Self-tapping screw
M020	24818013Y	Insulator A	U11	1H412554-2	NAETC-5854-2,Position sensor PC board ass'y
M021	24818014Y	Insulator B	U12	1H412555-2	NAETC-5855-2,Chucking motor PC board ass'y
M022	24840111	Special screw	U13	1H412556-2	NAETC-5856-2,Loading motor PC board ass'y
M024	838130088	3TTB+8B,Self-tapping screw	U14	1H412557-2	NASW-5857-2,Chucking switch PC board ass'y
M025	28175255	Isolated plate	U15	1H412558-2	NASW-5858-2,Roulette in/out PC board ass'y
M027	24840142	Tray	U16	1H412559-2	NAETC-5859-2,Disc sensor PC board ass'y
M028	1H412902	RF-310TA-11400,Roulette motor ass'y			
M030	24822018Y	Retainer			
M031	838130088	3TTB+8B,self-tapping screw			
M033	24810045A	Worm ass'y			

LOCATION OF MECHANISM PARTS

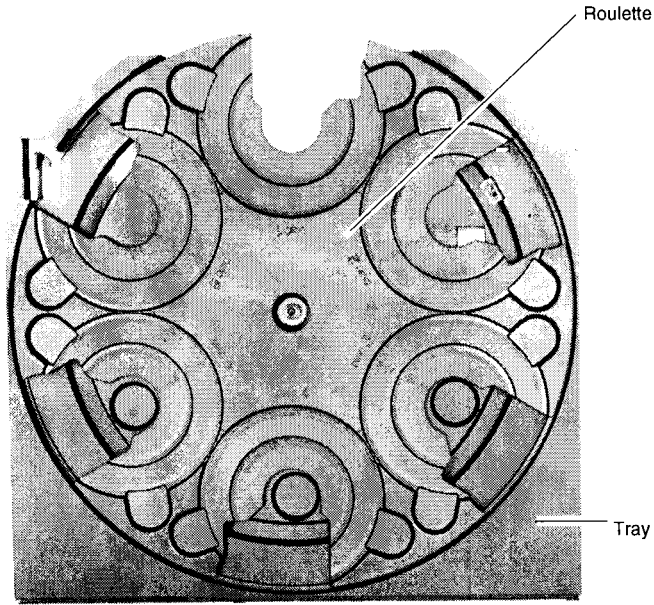

Mechanism chassis ass'y (Top side)

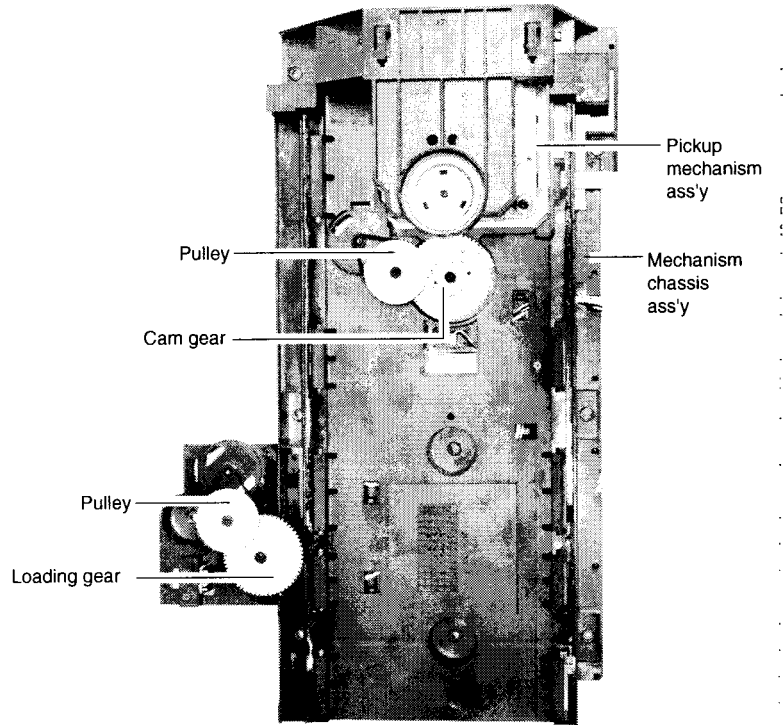

Mechanism chassis ass'y (Top side)

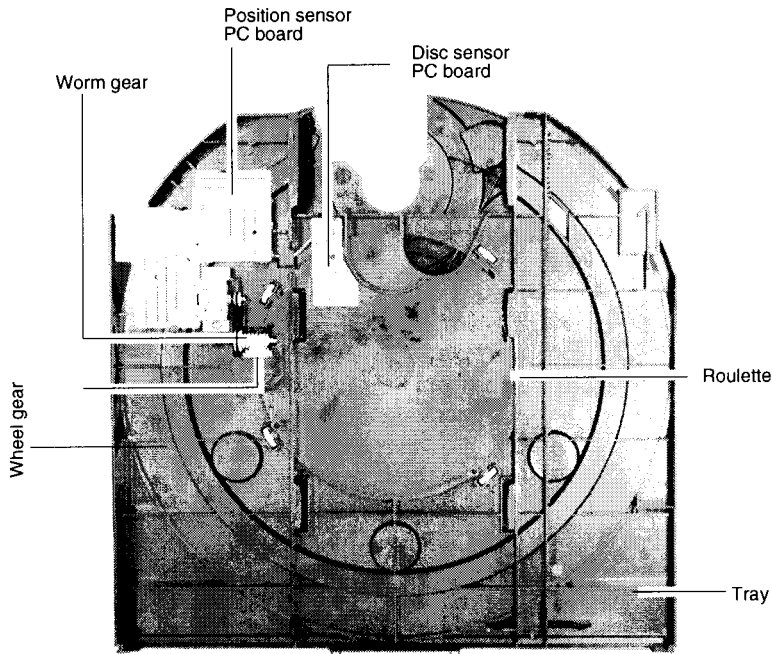

Mechanism chassis ass'y (Bottom side)

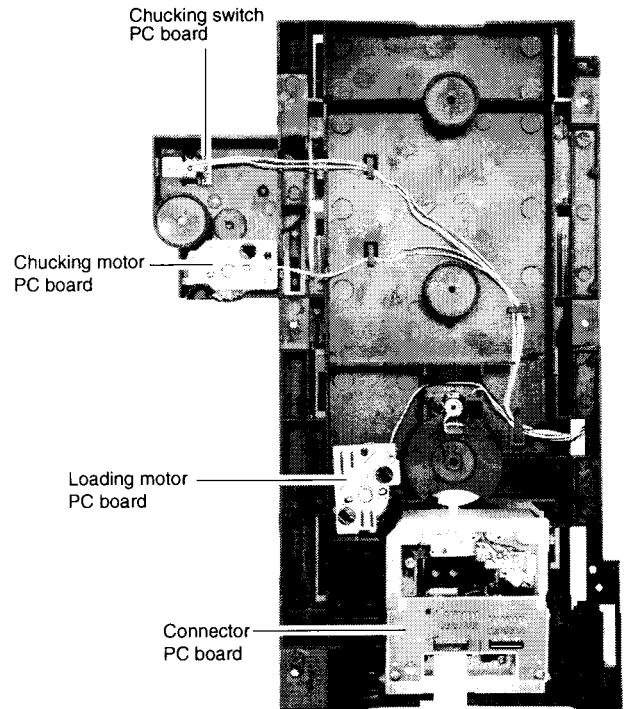

Mechanism chassis ass'y (Bottom side)

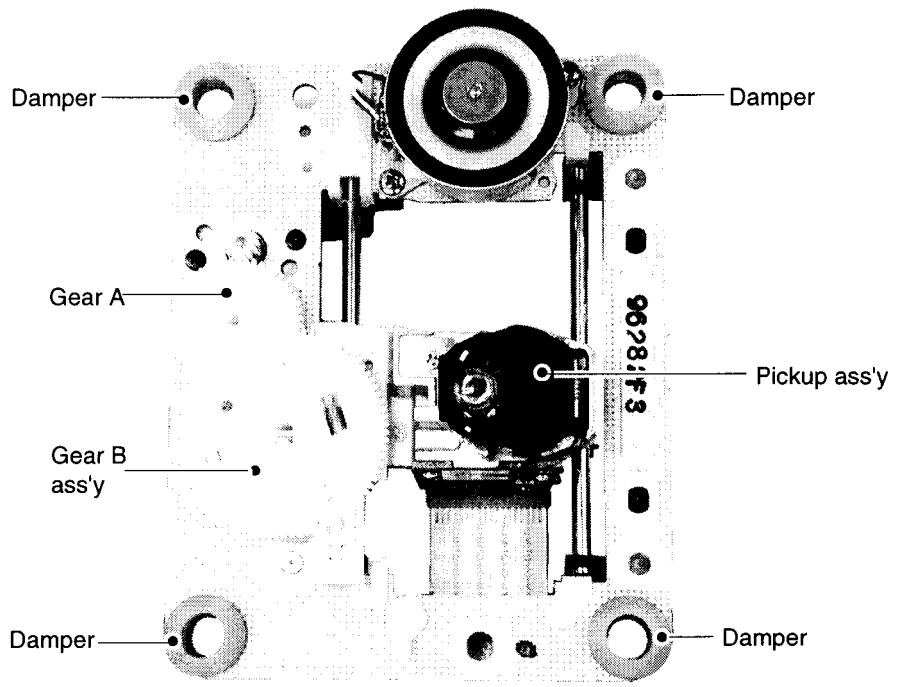

DVD pickup mechanism chassis ass'y (Top side)

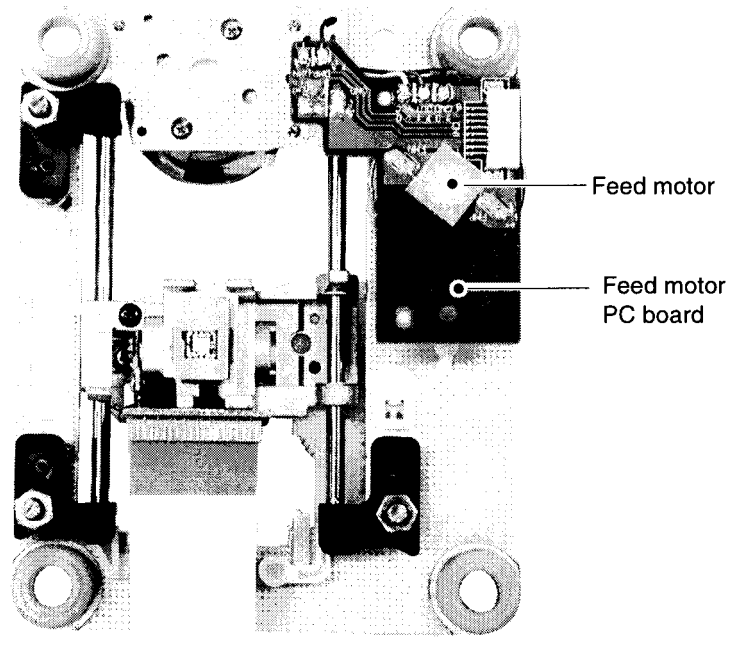

DVD pickup mechanism chassis ass'y (Bottom side)

SCHEMATIC DIAGRAM

A B C D E F G

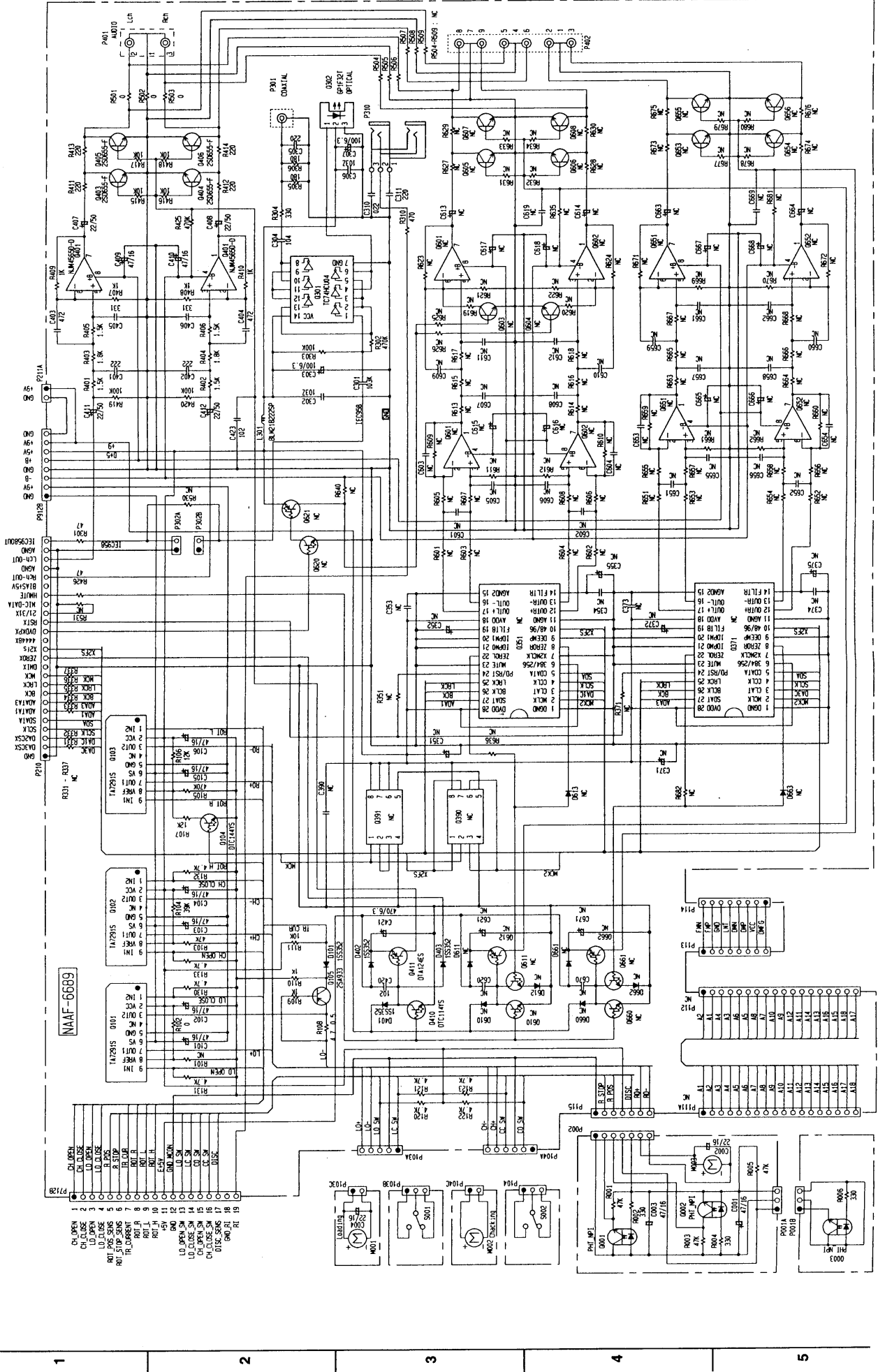

DPC-6

SCHEMATIC DIAGRAM

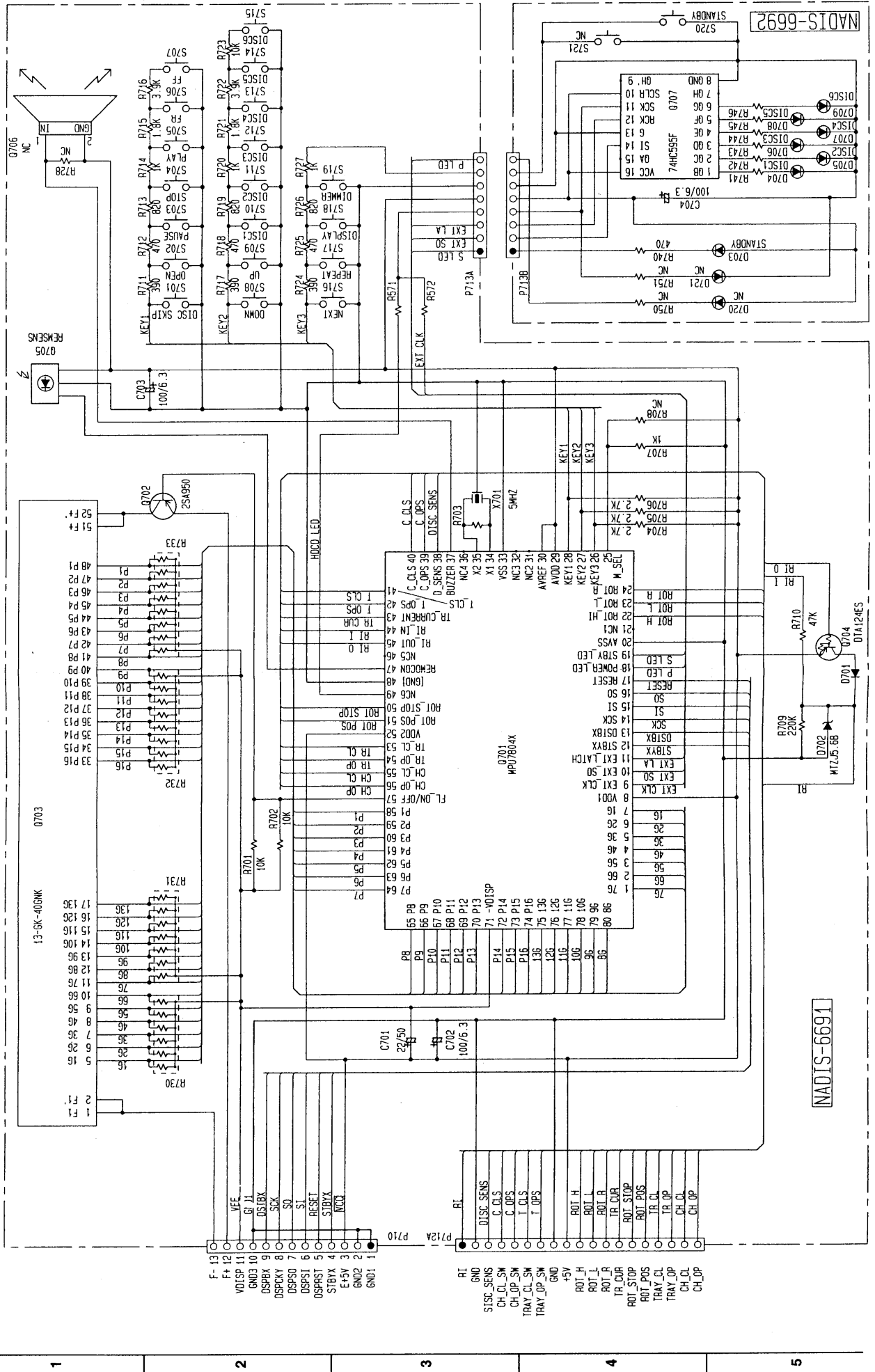

A B C D E F G

SCHEMATIC DIAGRAM

CAUTION

FOR CONTINUED PROTECTION AGAINST FIRE HAZARD, REPLACE ONLY WITH FUSE OF SAME TYPE AND RATING INDICATED.

THIS SYMBOL LOCATED NEAR THE FUSE INDICATES THAT THE FUSE USED IS SLOW OPERATING TYPE. FOR CONTINUED PROTECTION AGAINST FIRE HAZARD, REPLACE WITH SAME TYPE FUSE. FOR FUSE RATING REFER TO THE MARKING ADJACENT TO THE SYMBOL.

ATTENTION

AFIN D'ASSURER UNE PROTECTION PERMANENTE CONTRE LES RISQUES D'INCENDIE, REMPLACER UNIQUEMENT PAR UN FUSIBLE DE MEME TYPE ET CALIBRATION COMME INDIQUE.

CE SYMBOLE

INDIQUE QUE LE FUSIBLE UTILISE EST A LENT, E POUR UNE PROTECTION PERMANENTE, N'UTILISER QUE DES FUSIBLES DE MEME TYPE. CE DERNIER EST INDIQUE LA OUI LE PRESENT SYMBOLE EST ADJESSE.

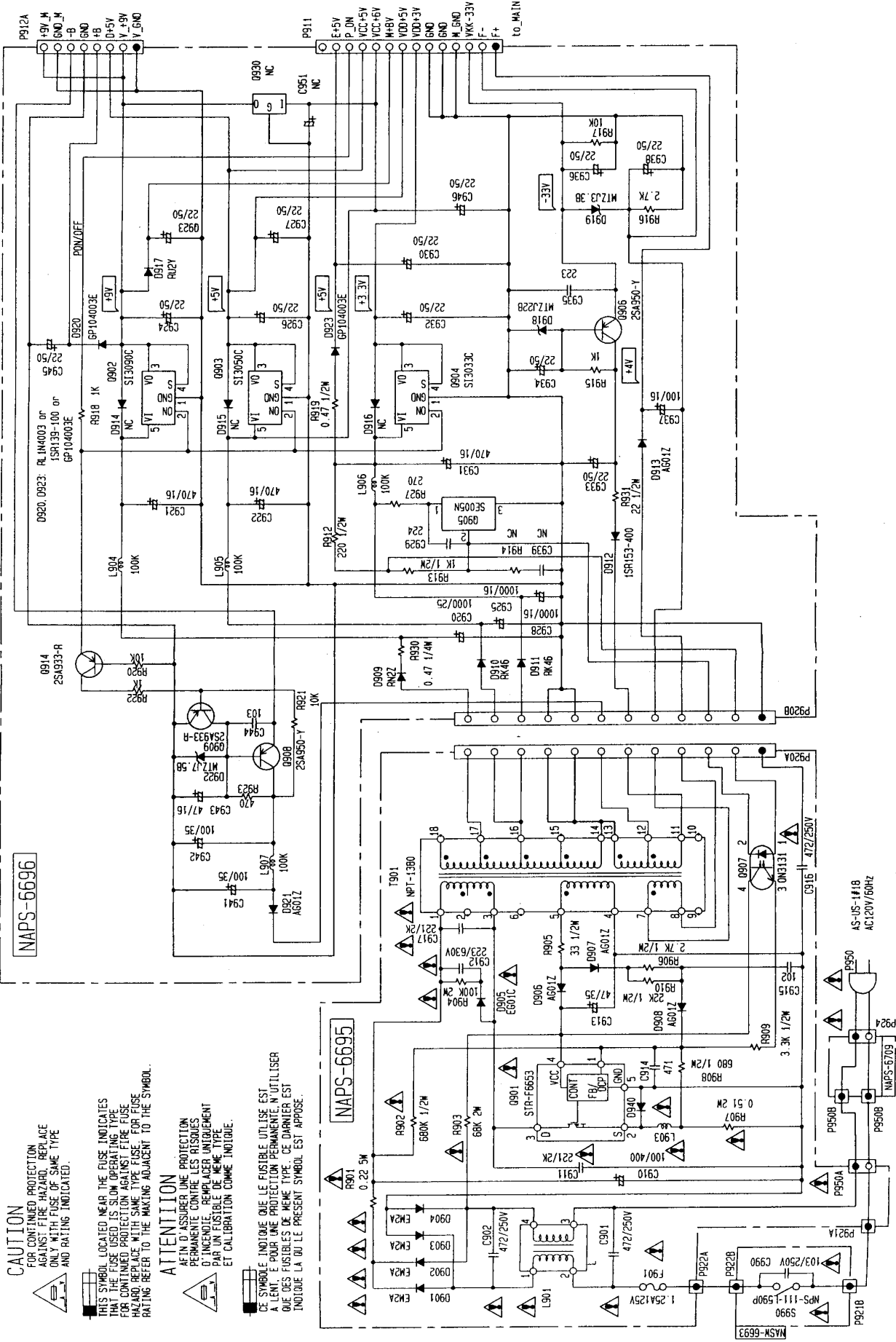

A B C D E F G

SCHEMATIC DIAGRAM

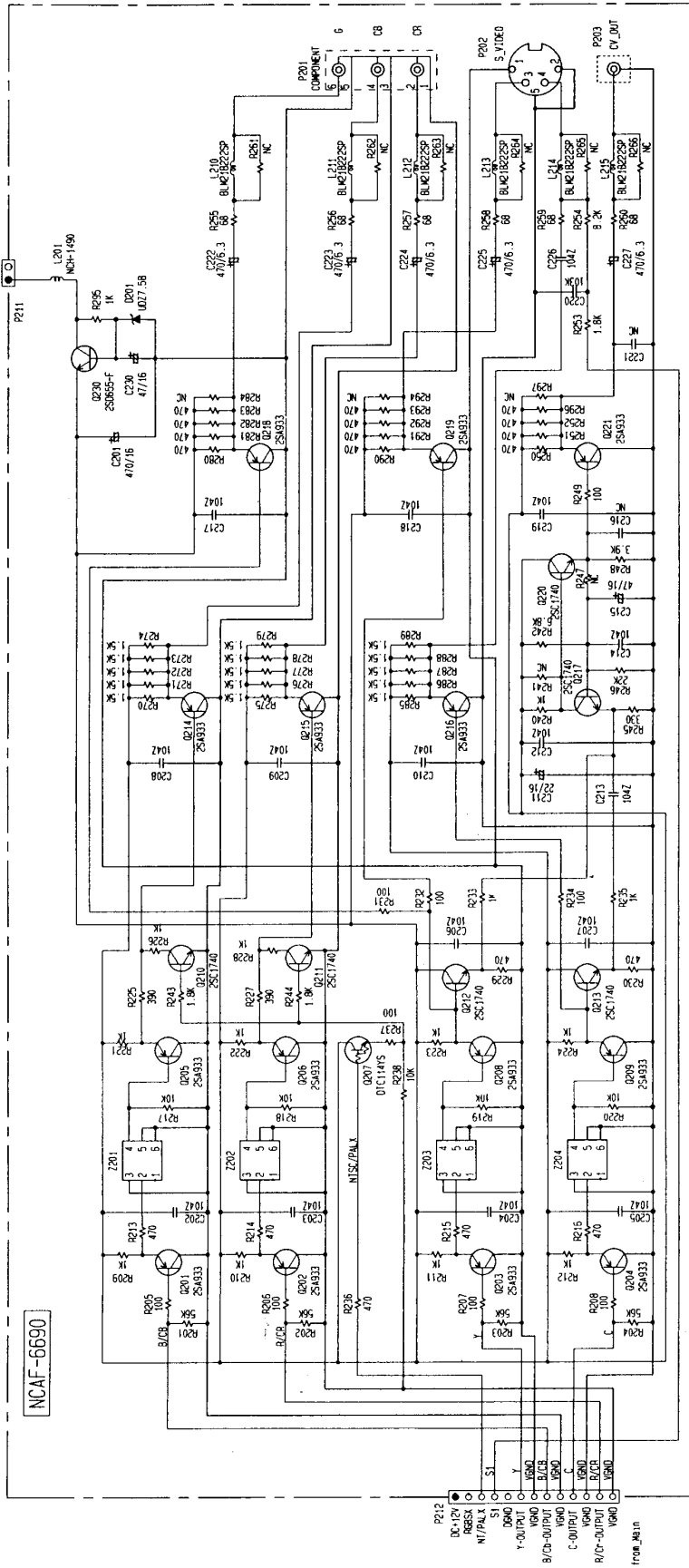

NOTE

- THE COMPONENTS IDENTIFIED BY MARK Δ ARE CRITICAL FOR SAFETY. REPLACE ONLY WITH PART NUMBER SPECIFIED.
- VOLTAGE MEASURED WITH VOLTMETER \square IS DC VOLTAGE, (NO INPUT SIGNAL).
- ALL Δ AND TRANSISTORS ARE EQUIVALENT TO 2SA1015-001 UNLESS OTHERWISE NOTED.
- ALL \square AND CAPACITORS ARE EQUIVALENT TO 2SA1015-001 UNLESS OTHERWISE NOTED.
- ALL DIMENSIONS ARE EQUIVALENT TO 1/8" UNLESS OTHERWISE NOTED.
- ELECTROLYTIC CAPACITORS (\square) ARE IN μ F/WV.
- ALL CAPACITORS ARE IN P/500V UNLESS OTHERWISE NOTED.
- EMI 0.2 μ -30F 331-8300F 333 μ 0.033 μ F.
- ALL RESISTORS ARE IN OHMS \square UNLESS OTHERWISE NOTED.
- THE THICK LINES ON P.C. BOARD ARE THE PRINTING SIDE OF THE PARTS.
- EMI \square PRINTING SIDE
- CIRCUIT IS SUBJECT TO CHANGE FOR IMPROVEMENT.

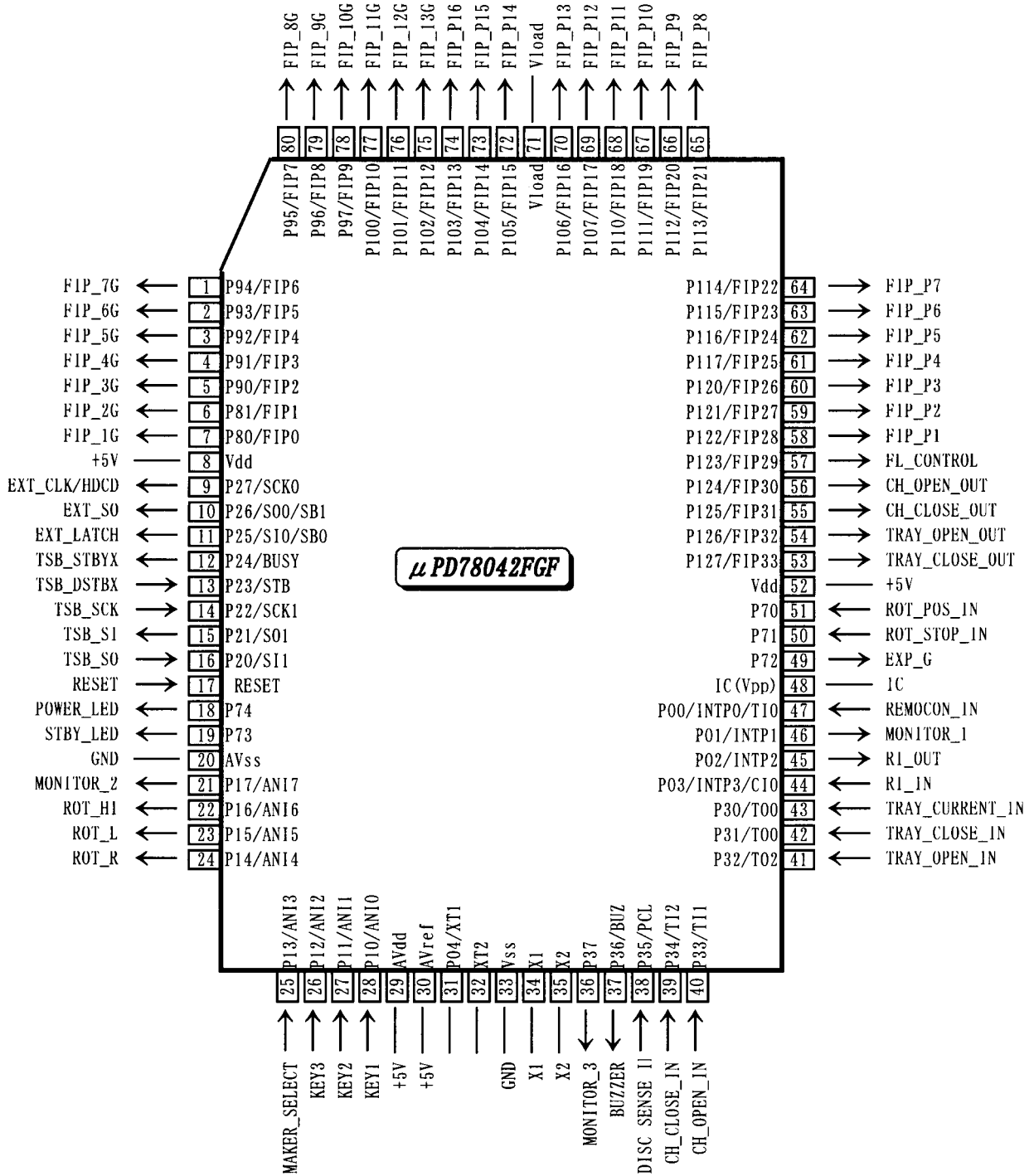

TC74HC595AF (8-Bit Shift Register/ Latch)

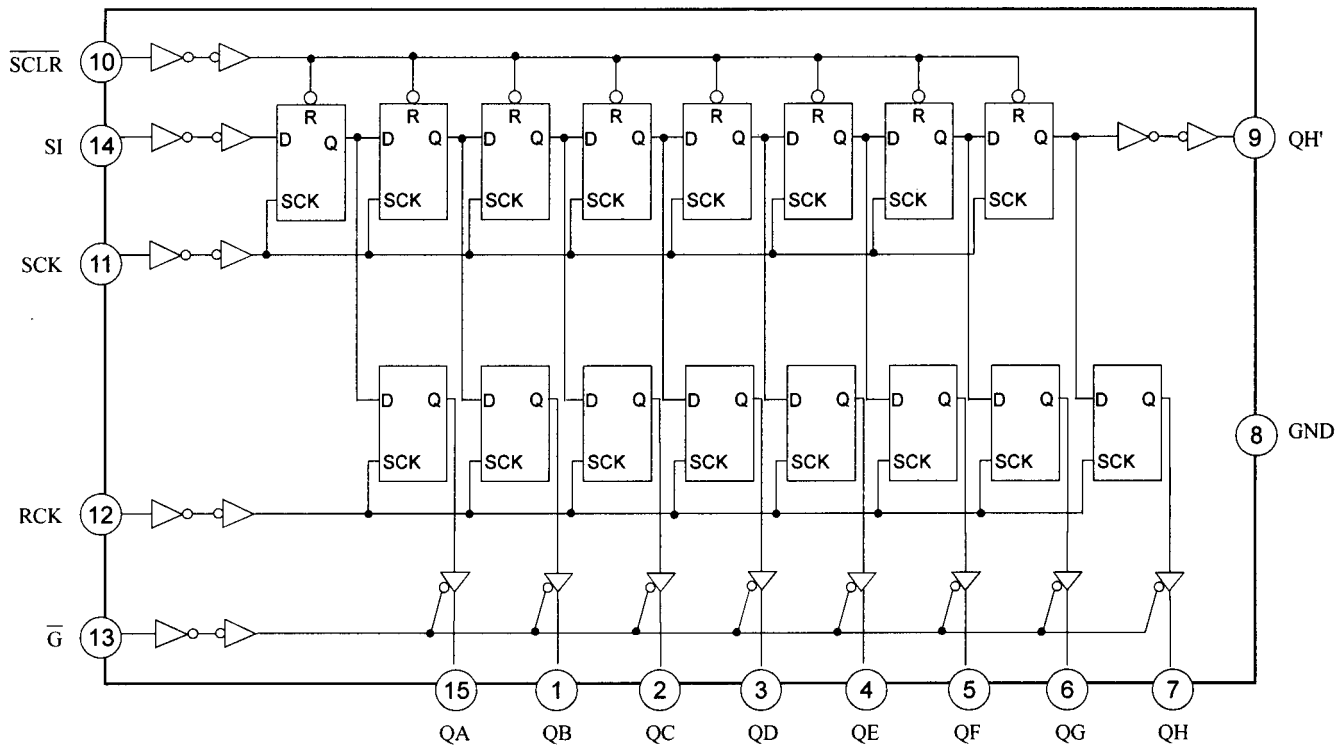

Truth Table

INPUT					FUNCTION
SI	SCK	$\overline{\text{SCLR}}$	SCK	$\overline{\text{G}}$	
X	X	X	X	H	QA thru QH outputs disable
X	X	X	X	L	QA thru QH outputs enable
X	X	L	X	X	Shift register is cleared.
L	\uparrow	H	X	X	First stage of S. R. becomes "L". Other stages store the data of previous stage, respectively.
H	\uparrow	H	X	X	First stage of S. R. becomes "H". Other stages store the data of previous stage, respectively.
X	\downarrow	H	X	X	State of S. R. is not changed.
X	X	X	\uparrow	X	S. R. data is stored into storage register.
X	X	X	\downarrow	X	Storage register stage is not changed.

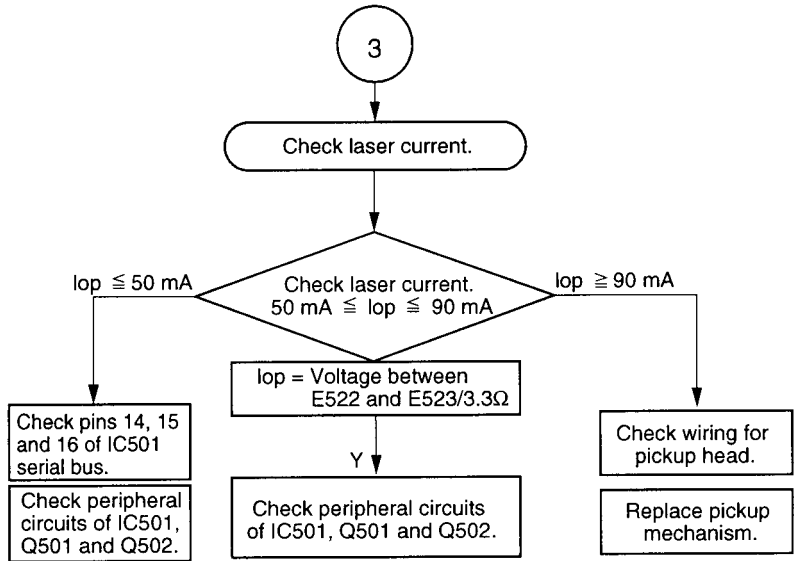
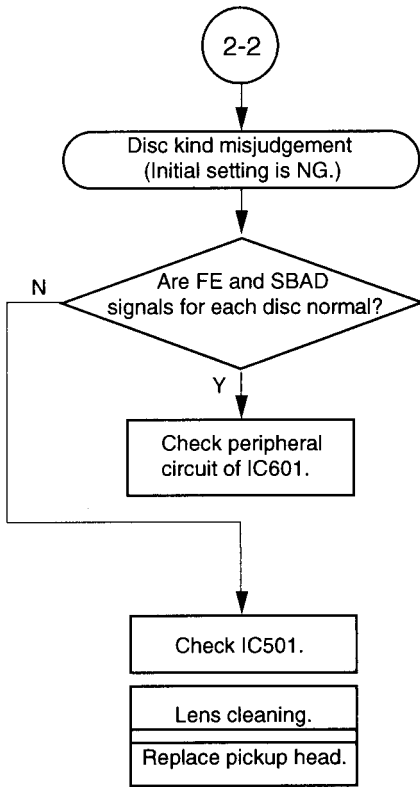

**DVD single (single-layer) disc
detection waveform**

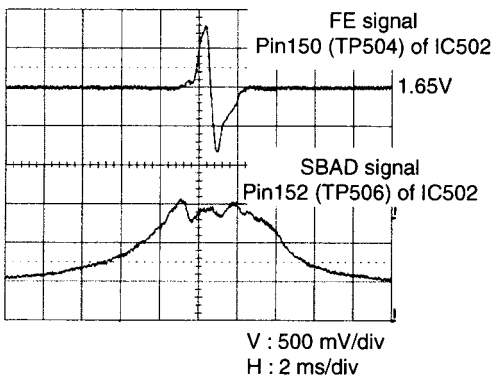

**DVD dual (dual-layer) disc
detection waveform**

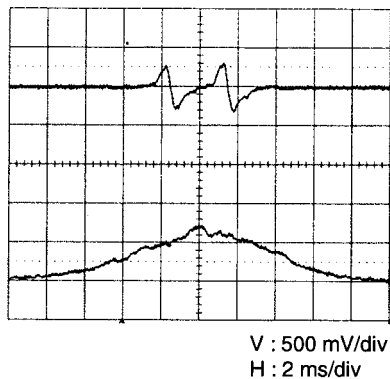

**CD disc
detection waveform**

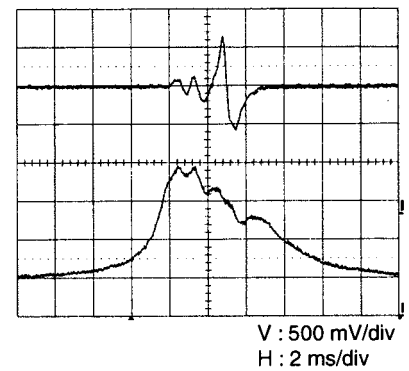

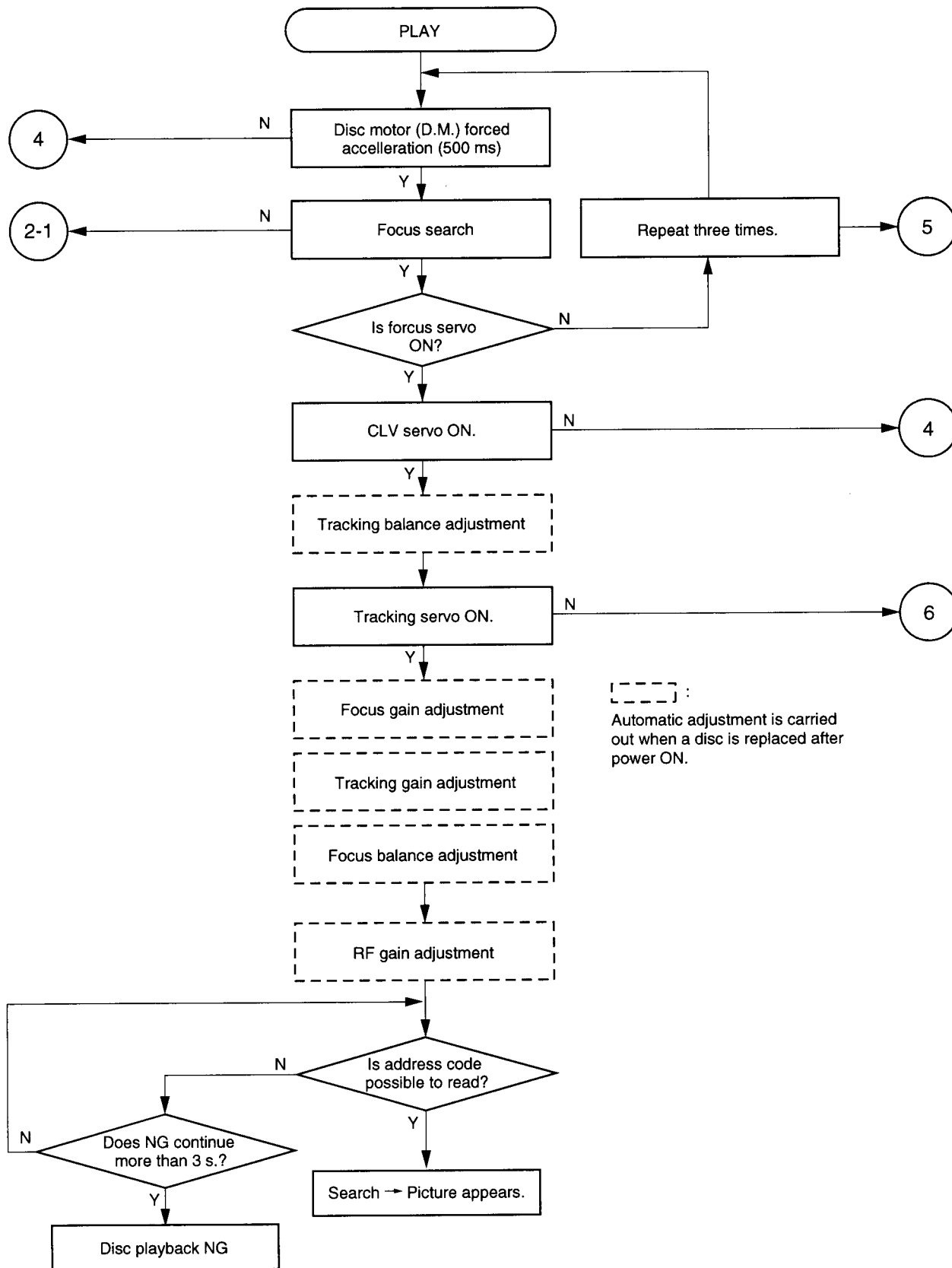

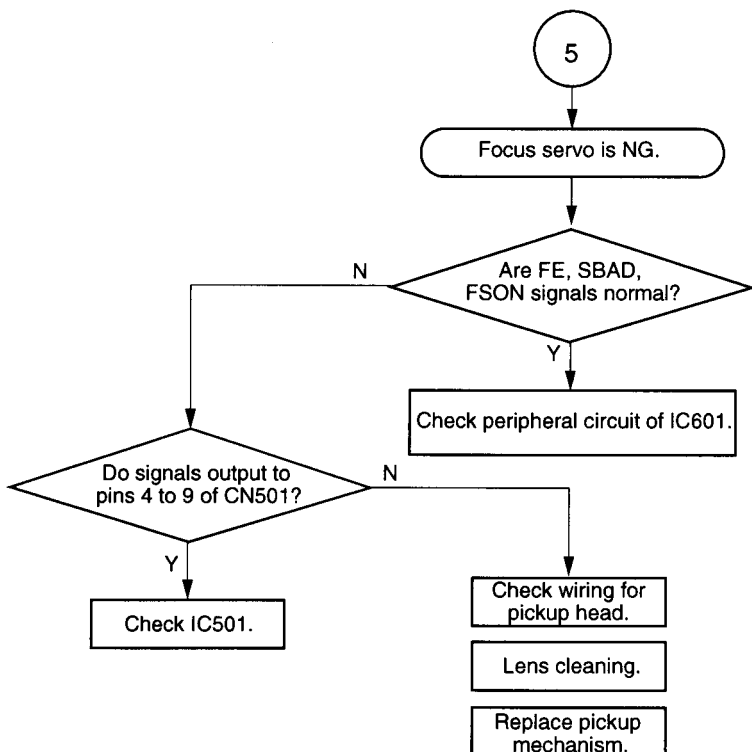
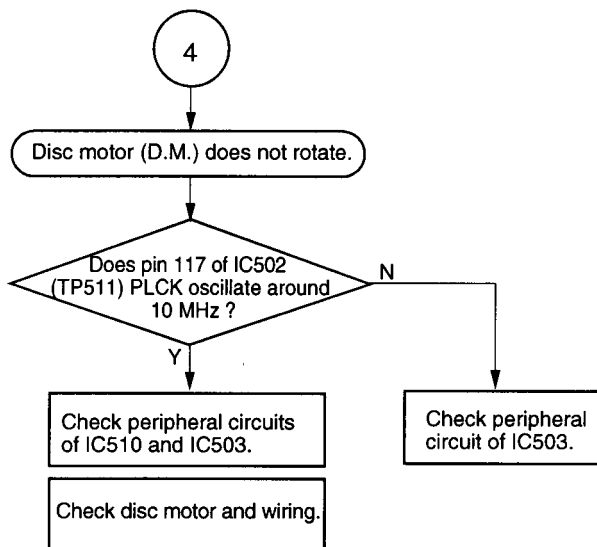

Focus servo ON signal waveform

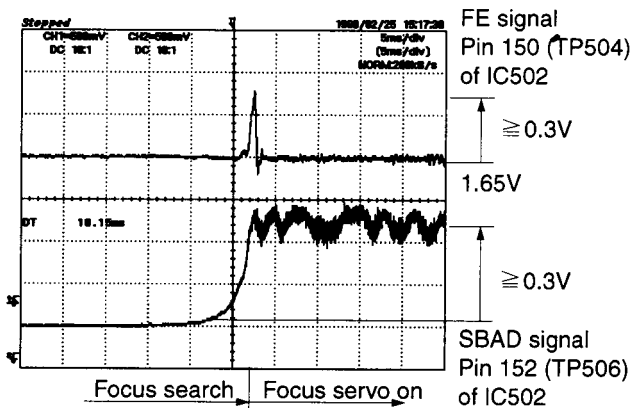

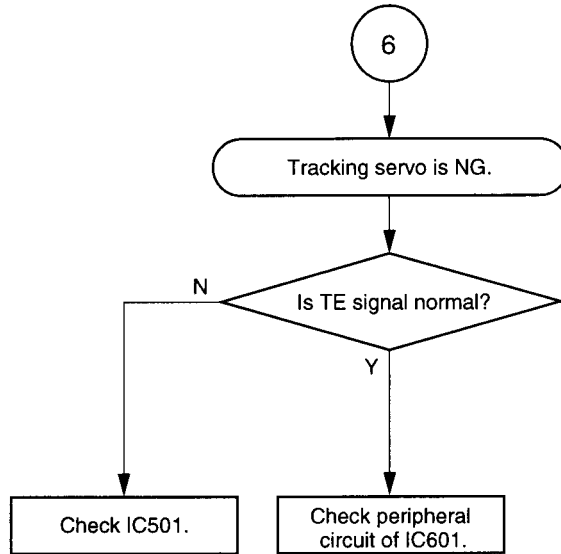

Signal waveform at tracking servo ON (CD)

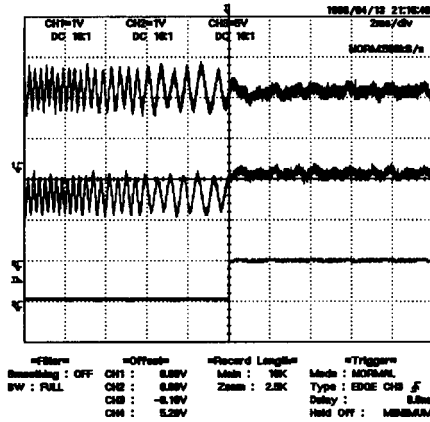

ON search Tracking servo on

Signal waveform at tracking servo ON (DVD)

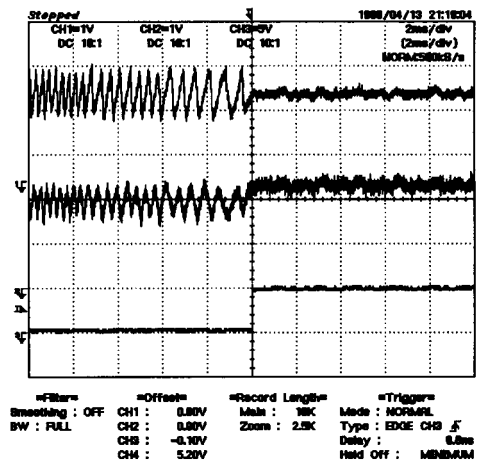

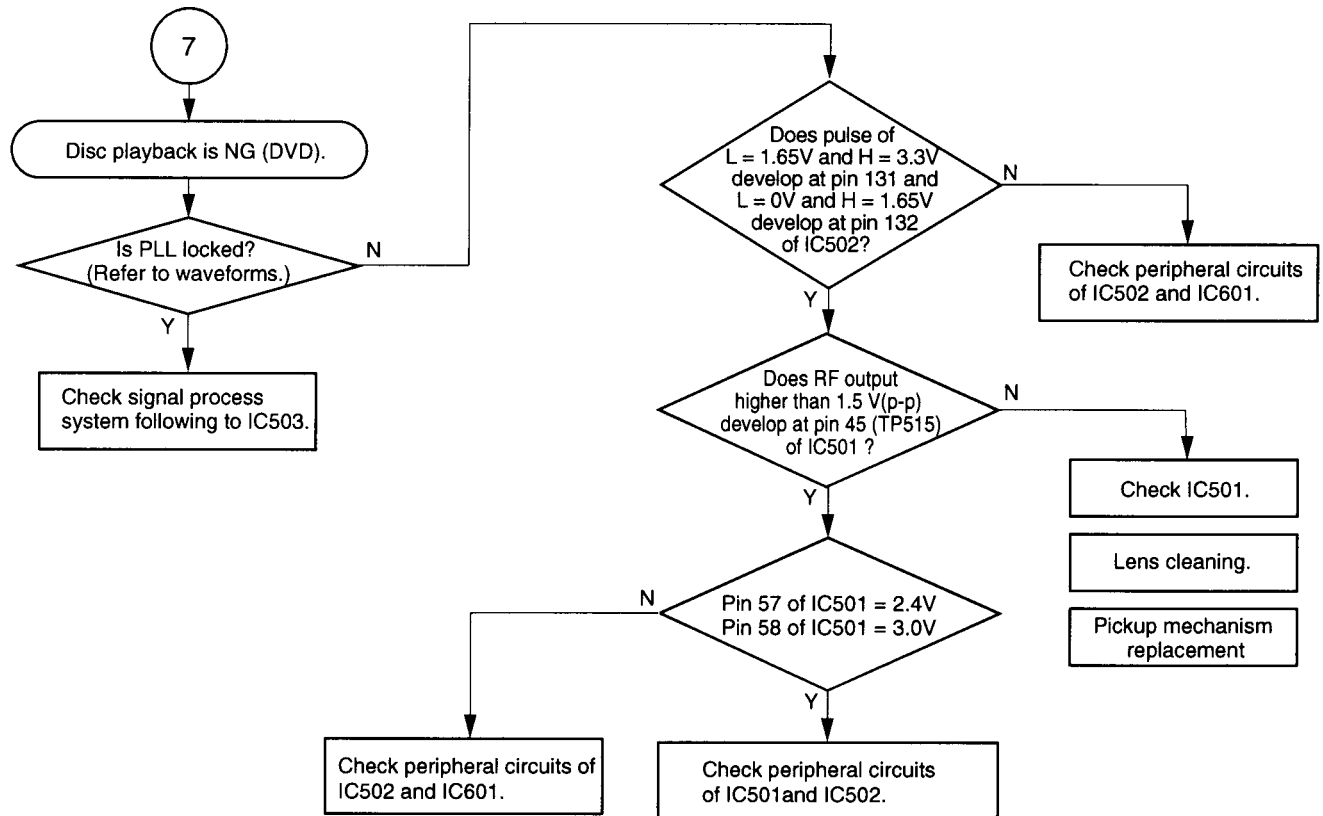

DVD RF signal

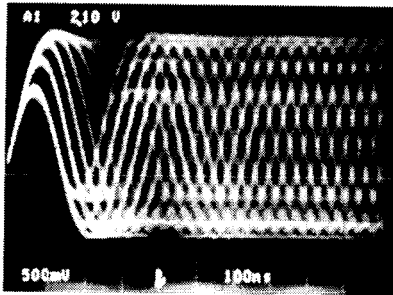

DVD RF signal
Pin 45 (TP515) of IC501

V : 500 mV/div
H : 50 ns/div

DVD playback waveform

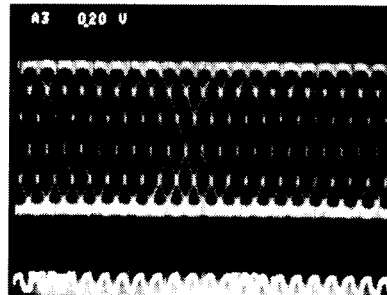

DVD RF signal
Pin 45 (TP515) of IC501

DVD PLCK
Pin 117 (TP511) of IC502

CH1 : TP515 DVDRF 500 mV/div
CH2 : TP511 DVDPLCK 5 V/div
50 ns/div

CD RF signal

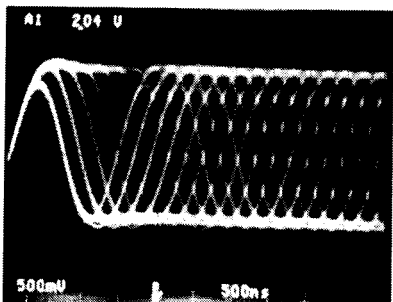

CD RF signal
Pin 45 (TP515) of IC501

V : 500 mV/div
H : 100 ns/div

CD playback waveform

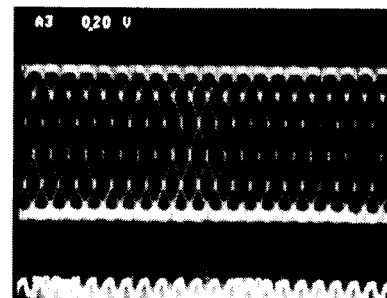

CD RF signal
Pin 45 (TP515) of IC501

CD PLCK
Pin 117 (TP511) of IC502

CH1 : TP515 CDRF 500 mV/div
CH2 : TP511 CDPLCK 5 V/div
100 ns/div

LOCATION DIAGRAM OF SERVO TEST POINT

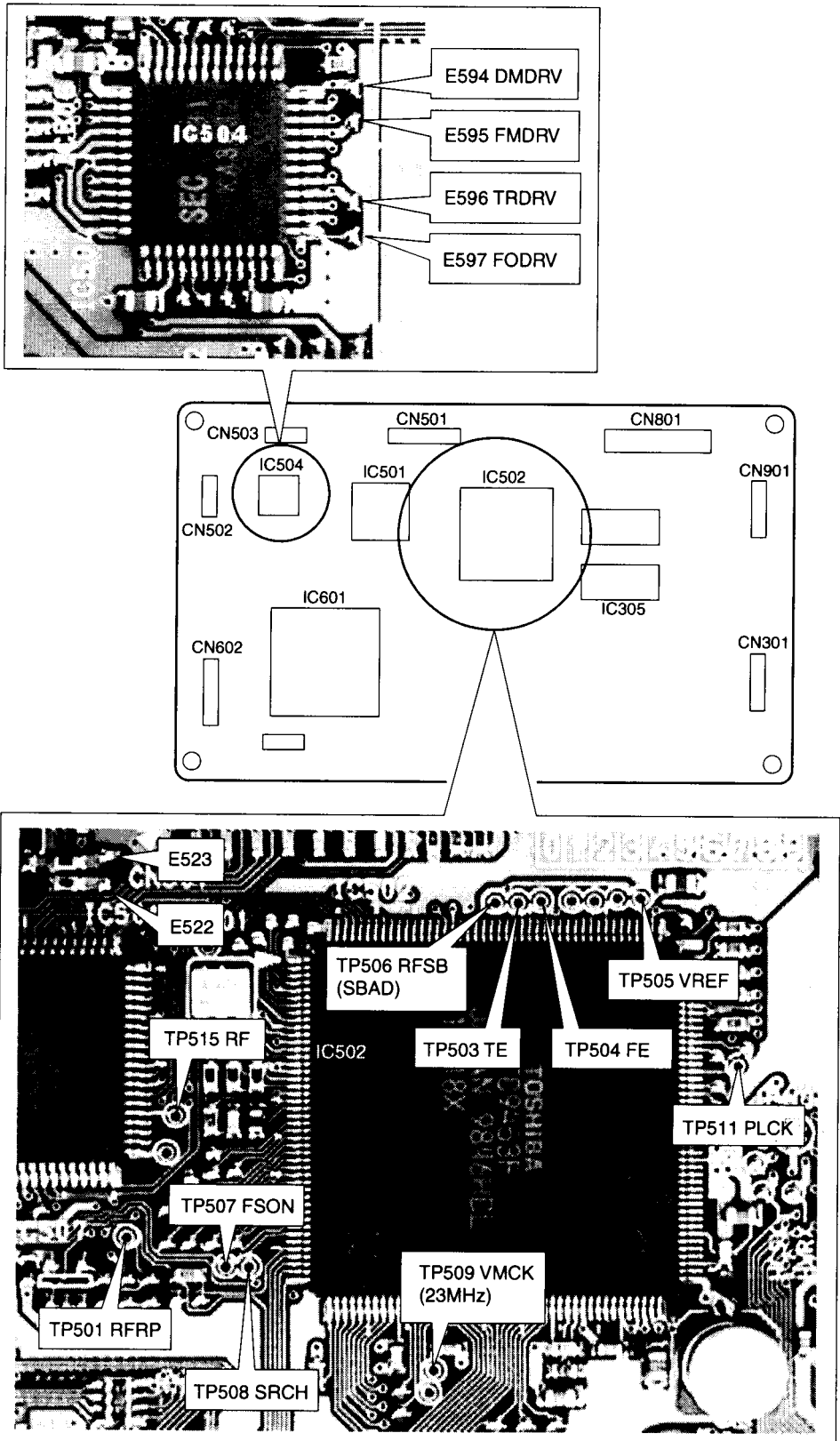

MECHANICAL PARTS LIST

REF. No.	PART No.	DESCRIPTION
MP01	79070415	MECHA ASSY-PU
MP36	79070417	RUBBER,DUMPER,FRONT
MP37	79070418	RUBBER,DUMPER,REAR
MP91	79070419	GEAR ASSY,KIT,B
MP92	79070420	GEAR ASSY,RACK
FM01	79070421	MOTOR ASSY,FEED, DC
MP16	79070422	GEAR A
RM01	79070427	MOTOR ASSY,LOADING, DC
MC14	79070428	BELT,LOAD
MC01	79070416	CHASSIS ASSY,MECHANISM

PARTS LIST (Main PC board)

LOCATION No.	PART No.	DESCRIPTION	LOCATION No.	PART No.	DESCRIPTION
Integrated circuits					
IC201	NSP 79040154	IC TC203G08AF-0103(Z)	IC616	NSP 79040007	IC TC7S08F
IC202	NSP 79010145	IC NN514800AJ-G0T	IC617	NSP 79040087	IC TC7W241FU
IC301	NSP 79040122	IC MD36710X	IC901	NSP 79040151	IC PCM1727E
IC302	NSP 79040063	IC HY57V16160ATC-10	IC902	NSP 79040119	IC TC7SH86F
IC305	NSP 79040063	IC HY57V16160ATC-10	IC903	NSP 79040102	IC NJM2370U50
IC306	NSP 79040096	IC ADV7170KS	IC904	NSP 79040087	IC TC7W241FU
IC307	NSP 79040130	IC NJU6321PE-TE1	Transistors		
IC308	NSP 79040011	IC TC7W04F	Q501	NSP 79050036	Transistor, Chip 2SA1832-GR
IC311	NSP 79040013	IC TC7W74F	Q502	NSP 79050042	Transistor, Chip 2SC2883-Y
IC312	NSP 79040119	IC TC7SH86F	Q503	NSP 79050014	Transistor, Chip HN1C03F
IC313	NSP 79040119	IC TC7SH86F	Q601	NSP 79050031	Transistor, Chip DTA114EKA
IC314	NSP 79040119	IC TC7SH86F	Miscellaneous		
IC501	NSP 79040152	IC TA1293F	X301	NSP 79089003	Oscillator SMD49.27MHz
IC502	NSP 79040149	IC TC9453F	X501	NSP 79089021	Ceramic Oscillator 22.58MHz
IC503	NSP 79040148	IC V53C16128HK-30	X601	NSP 79089022	Ceramic Oscillator 9.00MHz
IC504	NSP 79040150	IC KA3032			
IC506	NSP 79040006	IC TC7S04F	EU01	79083019	PC Board Assy Main PCB
IC508	NSP 79040066	IC UPC29L33T	NSP : Not spare part		
IC601	NSP 79040158	IC TMP94CS40AF-4401			
IC602	NSP 79040041	IC PST591-IDT			
IC607	NSP 79040007	IC TC7S08F			
IC613	NSP 79040070	IC S-2401AFJ-TB			
IC614	NSP 79040148	IC V53C16128HK-30			
IC615	NSP 79040153	IC MBM29F800BA55TN			

4. Confirmation of content of writing (all destinations)

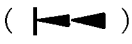
- 4-1. The power supply is turned on, and press the STANDBY/ON button to turn on the DVD player.
- 4-2. The "STOP" key and the "SKIP-DOWN" key are pushed at the same time in the state of No Disc. ()
- 4-3. It is confirmed that the display of monitor is as follow.

ROM1	Version	V*.*	-R1
ROM2	Version	V*.*	
OSD	Eng/Fre/spa		
VCD	On	BUZZER	Off
A.3D	Off	RANDOM	On
KARA	Off	DTS	On
VOCAL	Setup	DIMMER	3typ
V.3D	Off	V-FMT	Ntsc
JOG	Off	MPEG-A	On

5. Display confirmation of FL tube

All lighting of the FL tube only while "STOP" is being pushed when "STOP" key is pushed while pushing "SKIP-UP" key to the main body key.

6. Setting of the first setup screen mode

- 6-1. The "STOP" key and the "DIMMER" key on the main body key are pushed at the same time in the state of No Disc.
- 6-2. It is confirmed that the Setup screen goes out, and the character of "First Setup ON" has come out in lower right.
- 6-3. The power supply again by On after turning off the power supply, and it is confirmed that the first setup screen goes out by Standby/ON mode. (Never push the Setup key here)
- 6-4. The power supply is turned off, and the AC cord is pulled out.

7. Others

Factory setting confirmation

"SETUP" as follows each setting of the screen is confirmed.

LANGUAGE	
On-screen Language	ENG
Disc Menu Language	ENG
Audio Language	ENG
Subtitle Language	---
PICTURE	
TV Sharp	4:3LB
Black Level	NRML
AUDIO	Analog 2ch

MD area

LANGUAGE	
On-screen Language	ENG
Disc Menu Language	ENG
Audio Language	ENG
Subtitle Language	---
PICTURE	
TV Sharp	4:3LB
Black Level	NRML
AUDIO	Analog 2ch

PACKING VIEW

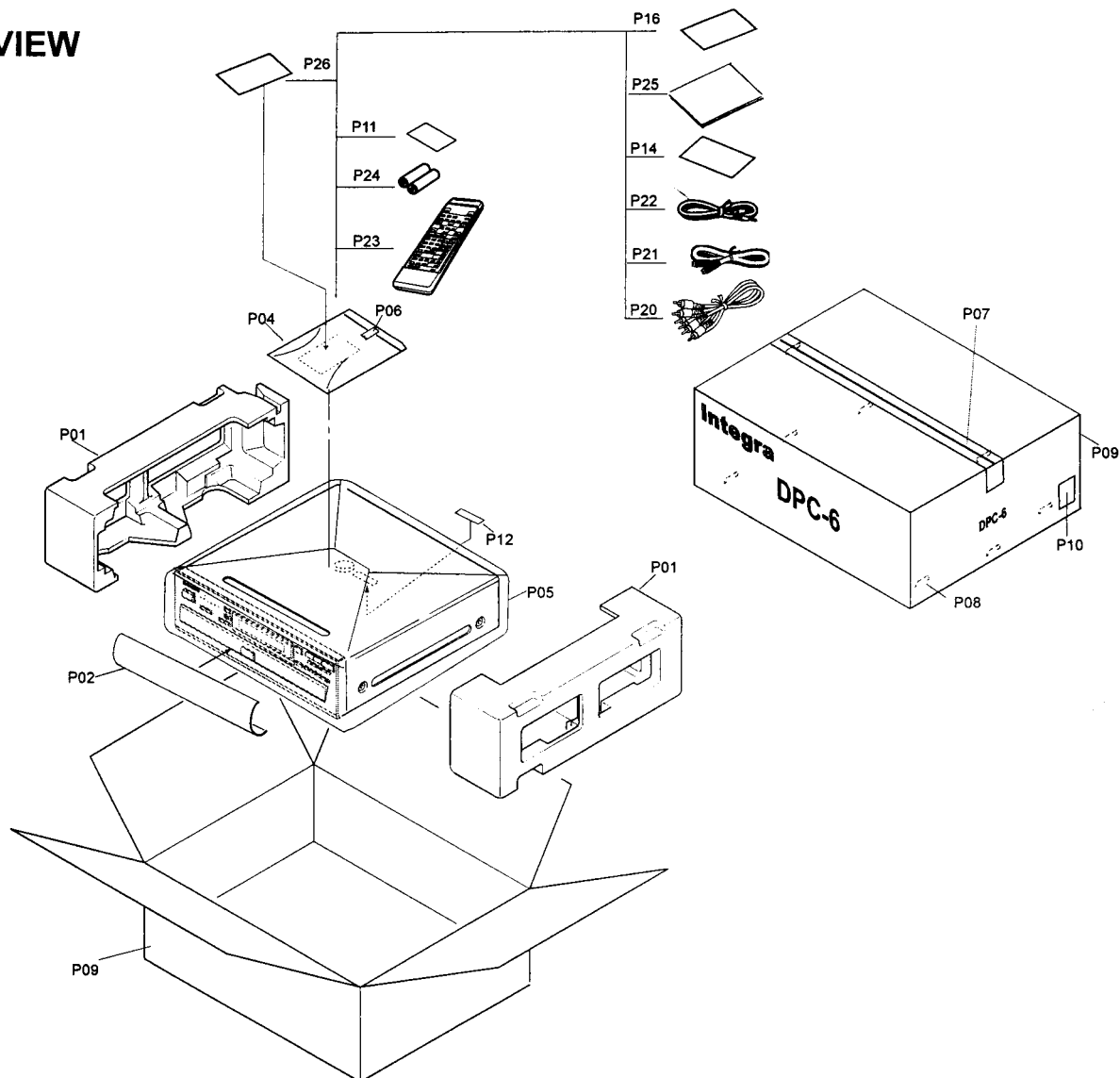

PARTS LIST

REF.NO.	PART NO.	DESCRIPTION	REF.NO.	PART NO.	DESCRIPTION
	P01	Pad AS		P14	Instruction sheet,(PAC)
	P02	Sheet, Door		P16	Sheet
	P04	Polybag,,350*250		P20	Pin cord,RCA3P(YWR)
	P05	Polybag,,1020x720		P21	Cord AS
	P06	Paper tape		P22	Remote controller cord
	P07	PP tape		P23	Remote controller,RC-406DV
	P08	Staple		P24	Battery,UM-3
	P09	Carton box		P25	Instruction manual,E(DPC-6)
	P10	UPC label		P26	Instruction sheet
	P11	Warranty card			Label
	P12	ROM label			

ONKYO CORPORATION

Sales & Product Planning Div. : 2-1, Nisshin-cho, Neyagawa-shi, OSAKA 572-8540, JAPAN
 Tel: 0720-31-8111 Fax: 0720-33-5222

ONKYO U.S.A. CORPORATION

200 Williams Drive, Ramesy, N.J. 07446, U.S.A.
 Tel: 201-825-7950 Fax : 201-825-8150 E-mail: onkyo@onkyousa.com

