

Integra SERVICE MANUAL

Aug, 2008

DVD CHANGER MODEL DPC-7.9

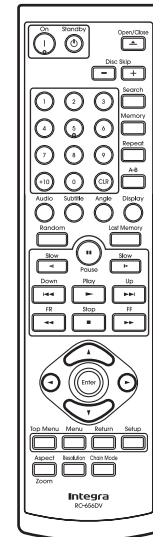
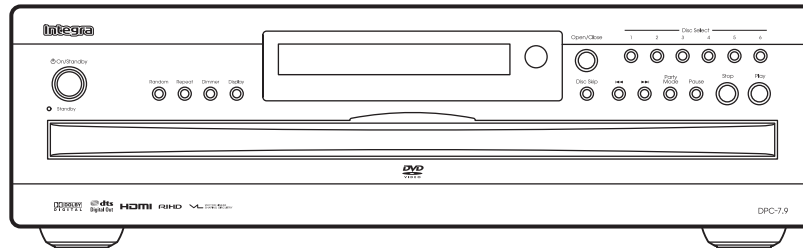

RC-656DV

Black model

BMDD	120V AC, 60Hz
BMUA, BMUP	100 - 240V AC, 50Hz

SAFETY-RELATED COMPONENT WARNING!!

COMPONENTS IDENTIFIED BY MARK  ON THE SCHEMATIC DIAGRAM AND IN THE PARTS LIST ARE CRITICAL FOR RISK OF FIRE AND ELECTRIC SHOCK. REPLACE THESE COMPONENTS WITH ONKYO PARTS WHOSE PART NUMBERS APPEAR AS SHOWN IN THIS MANUAL.

MAKE LEAKAGE-CURRENT OR RESISTANCE MEASUREMENTS TO DETERMINE THAT EXPOSED PARTS ARE ACCEPTABLY INSULATED FROM THE SUPPLY CIRCUIT BEFORE RETURNING THE APPLIANCE TO THE CUSTOMER.

EXPLODED VIEW-1

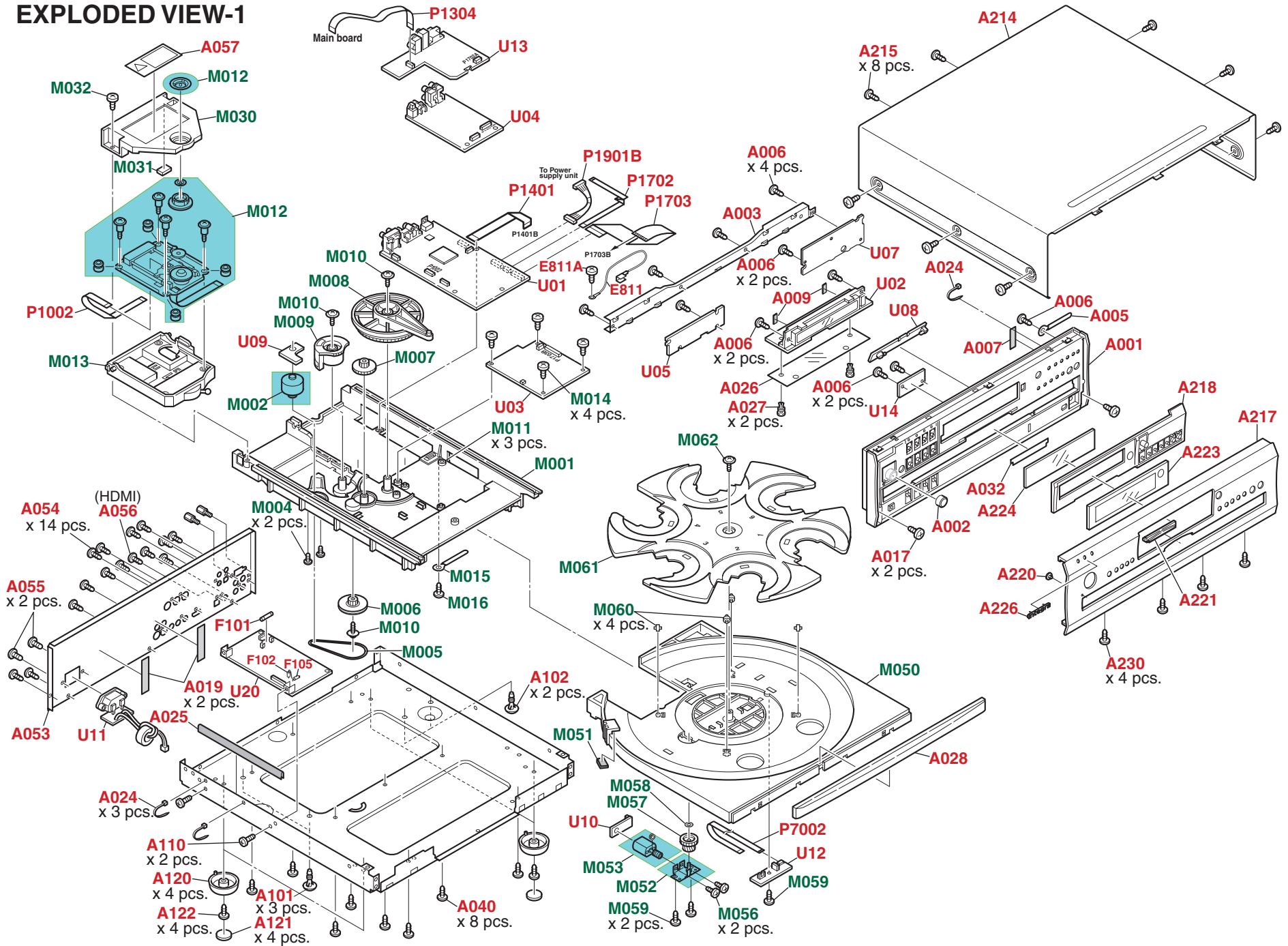

**EXPLODED VIEW
TRAVERSE MECHANISM**

**TRAVERSE MECHANISM A'SSY
TDT-2100SF-02
PART Number: 24801035**

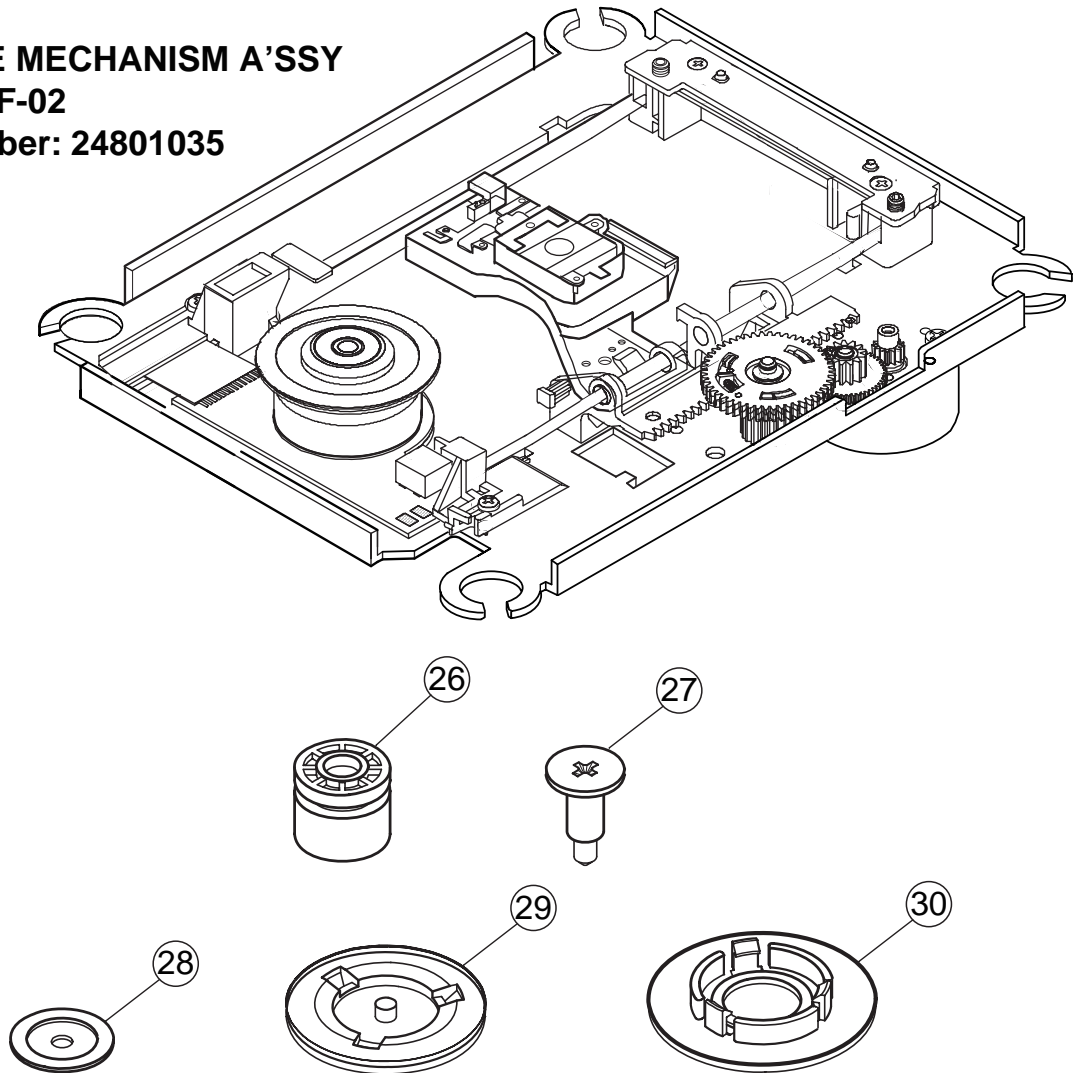

PARTS LIST

NO.	PART CODE	PART NAME
26	C2G083	DAMPER-IDLE
27	C1H012	SCREW-DAMPER-CR3
28	A7P085	CLAMP-T-M12H
29	A7G202	CLAMPER-H
30	A7G203	CLAMPER-L

BLOCK DIAGRAM

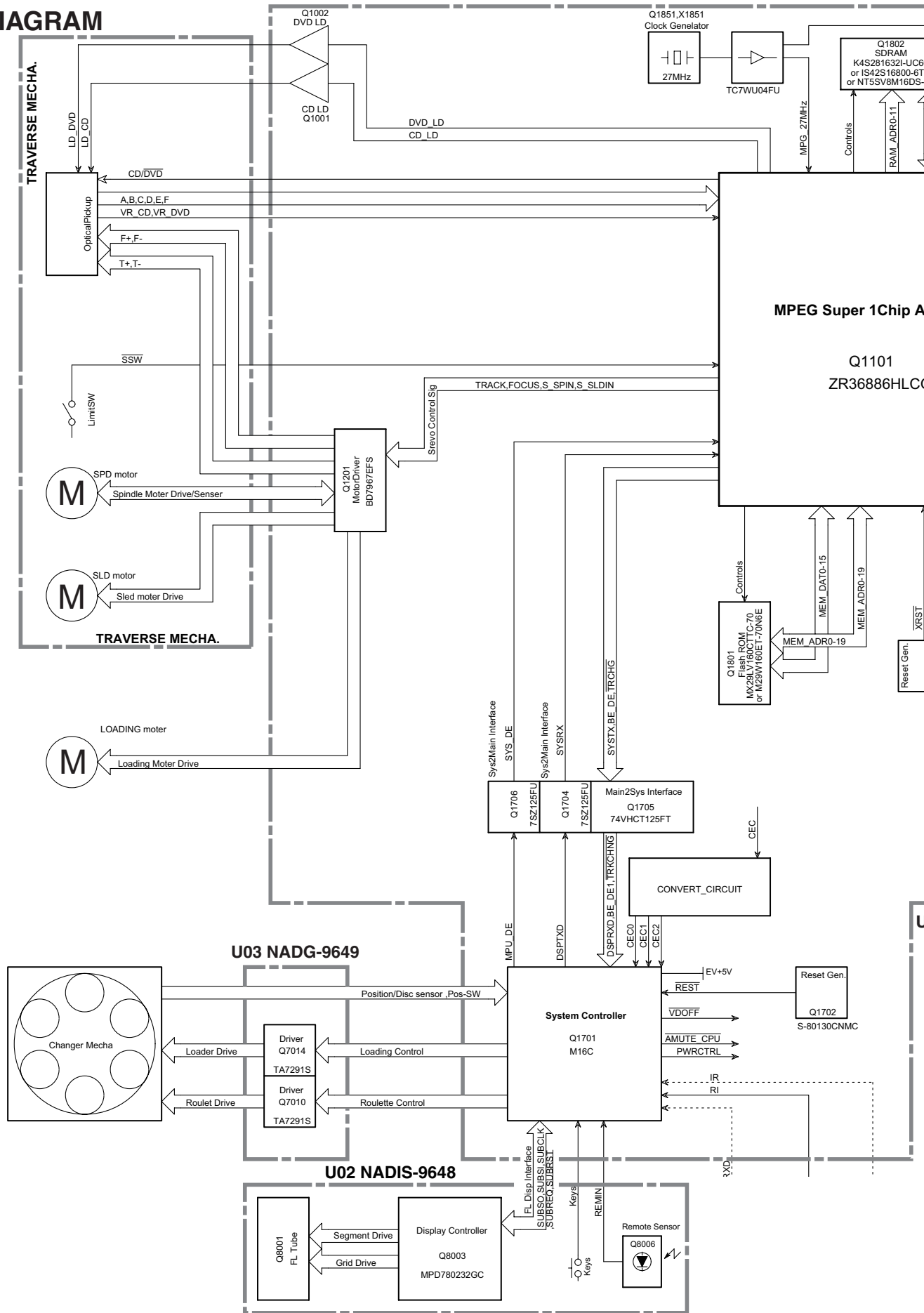

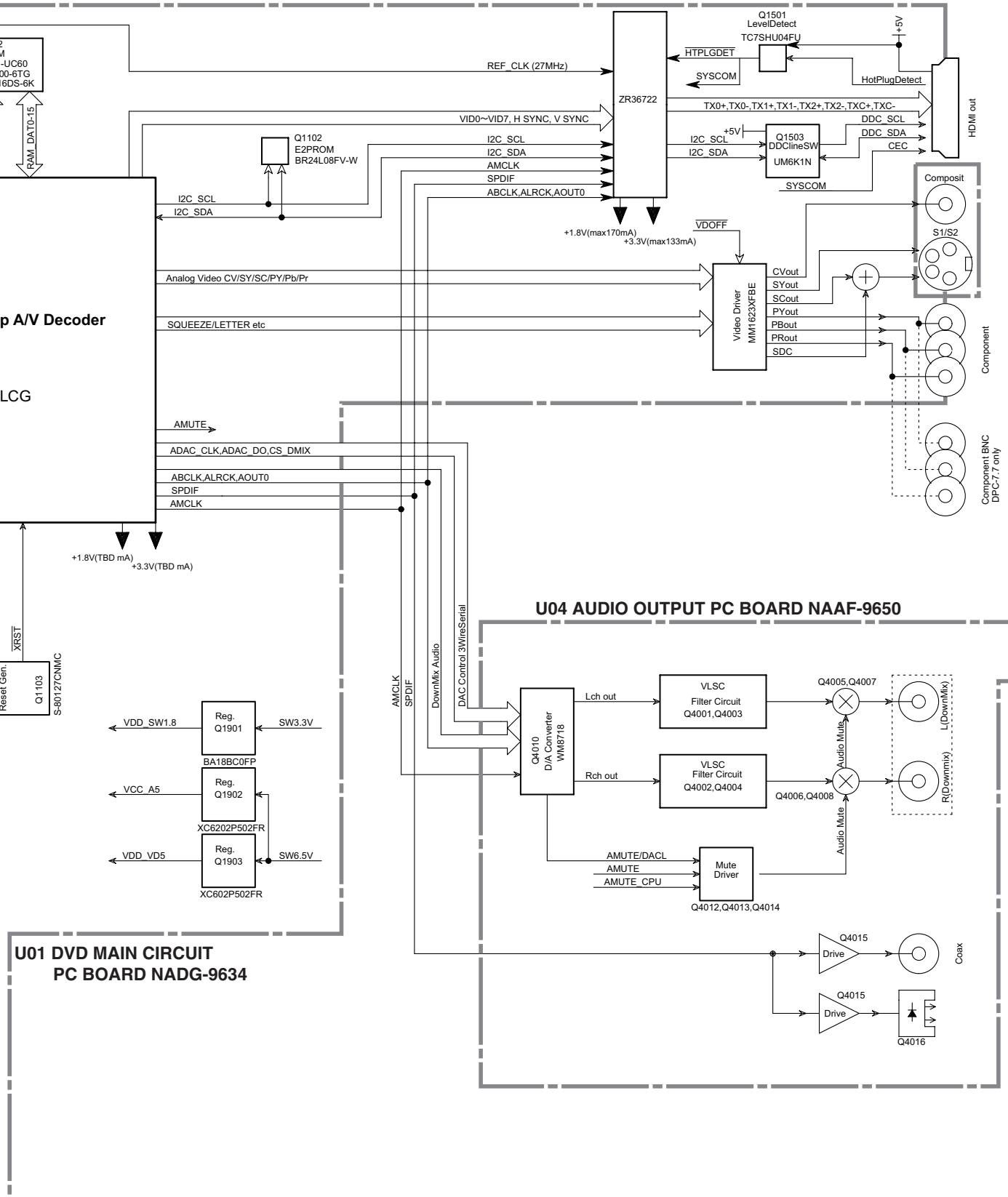

U01 DVD MAIN CIRCUIT PC BOARD NADG-9634

U04 AUDIO OUTPUT PC BOARD NAAF-9650

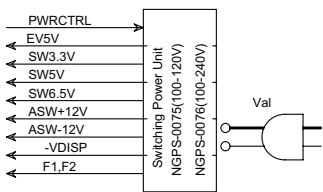

BLOCK DIAGRAM

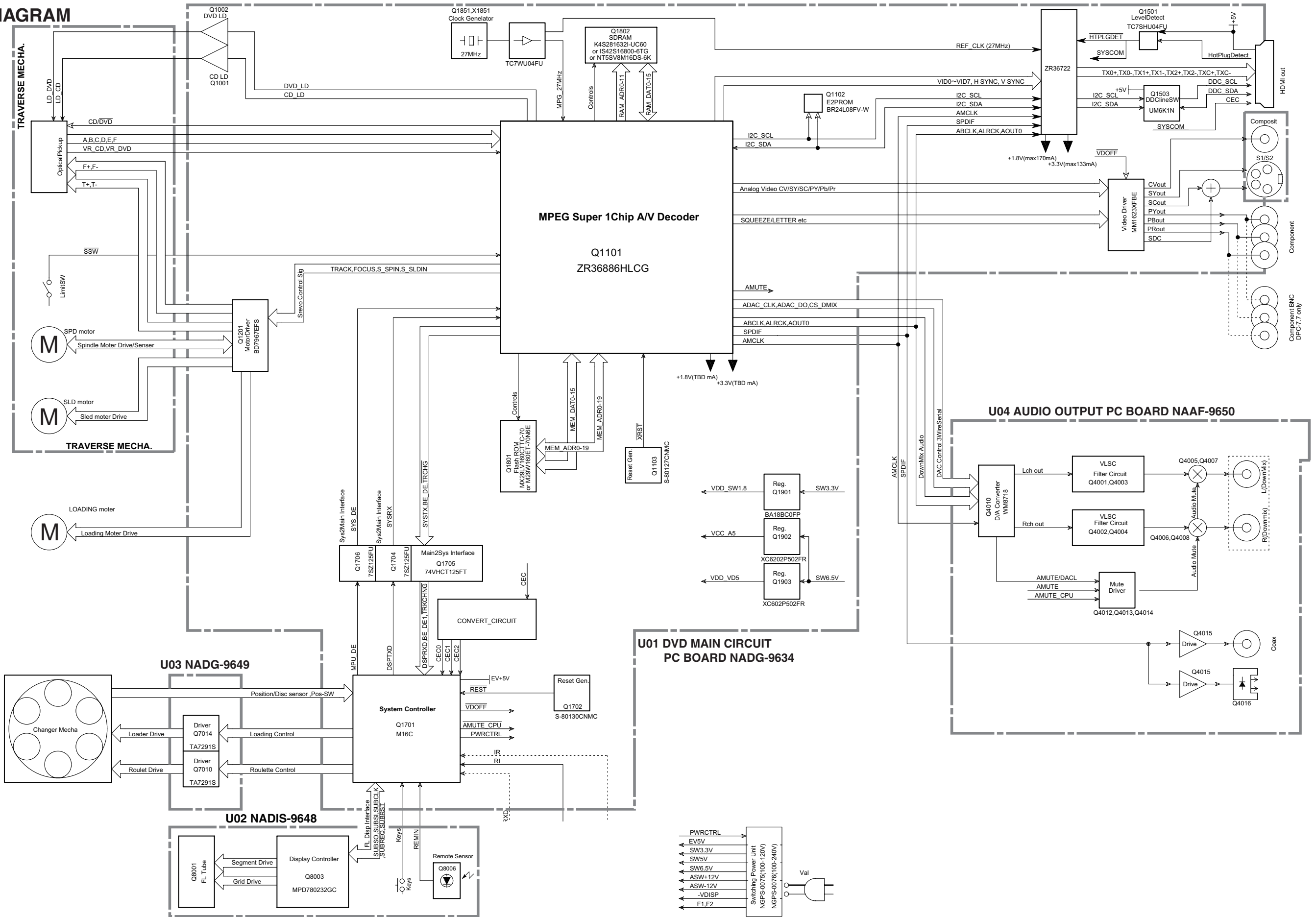

A

B

C

D

SHEMATIC DIAGRAM-1

DVD MAIN

CIRCUIT PC BOARD-1

NADG-9634

1

2

3

4

5

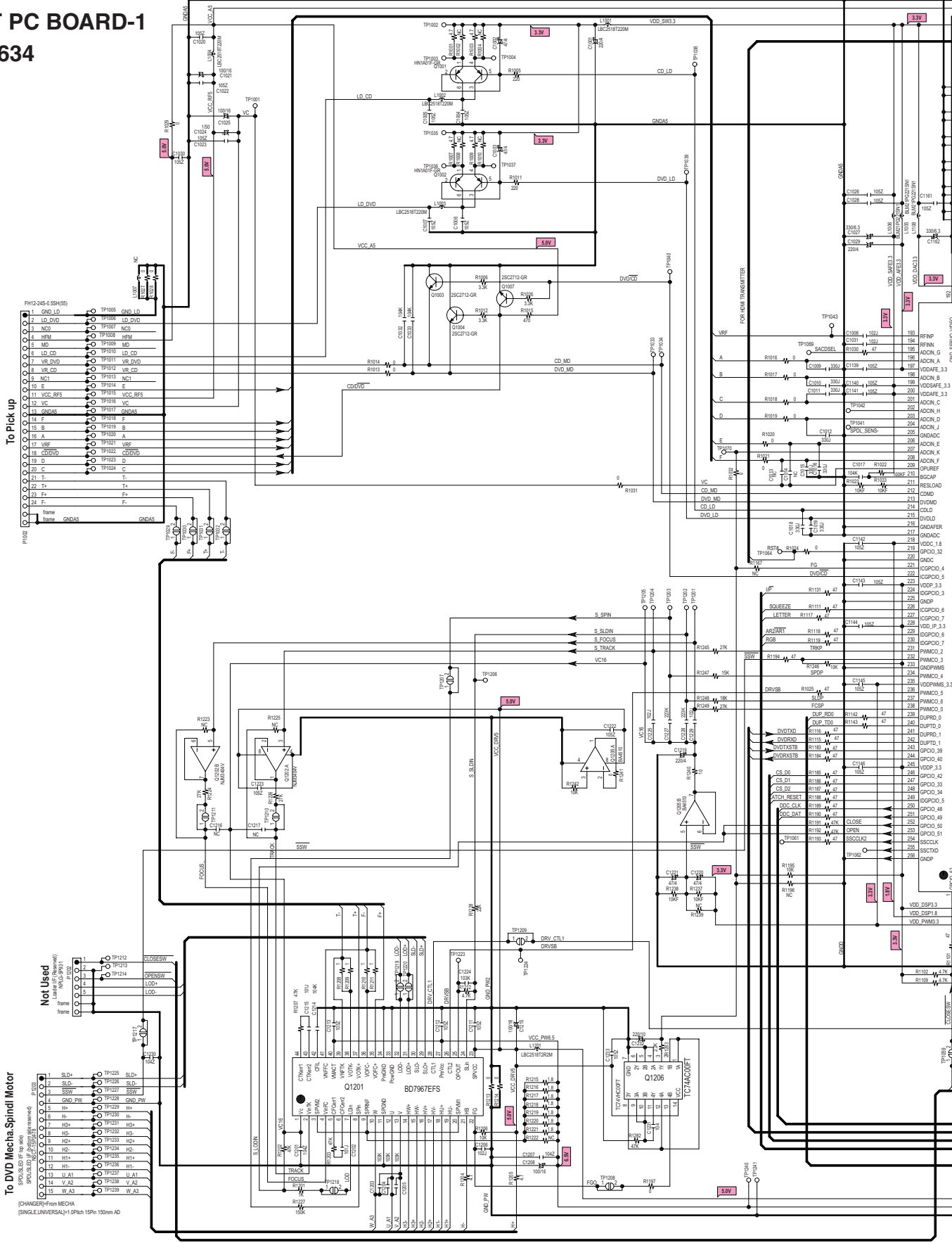

To Pick up

Not Used

To DVD Mecha Spindl Motor

CHANGES FROM MECHA
[SINGLE UNIVERSAL] 1.5Pin 15Pin 10mm AD

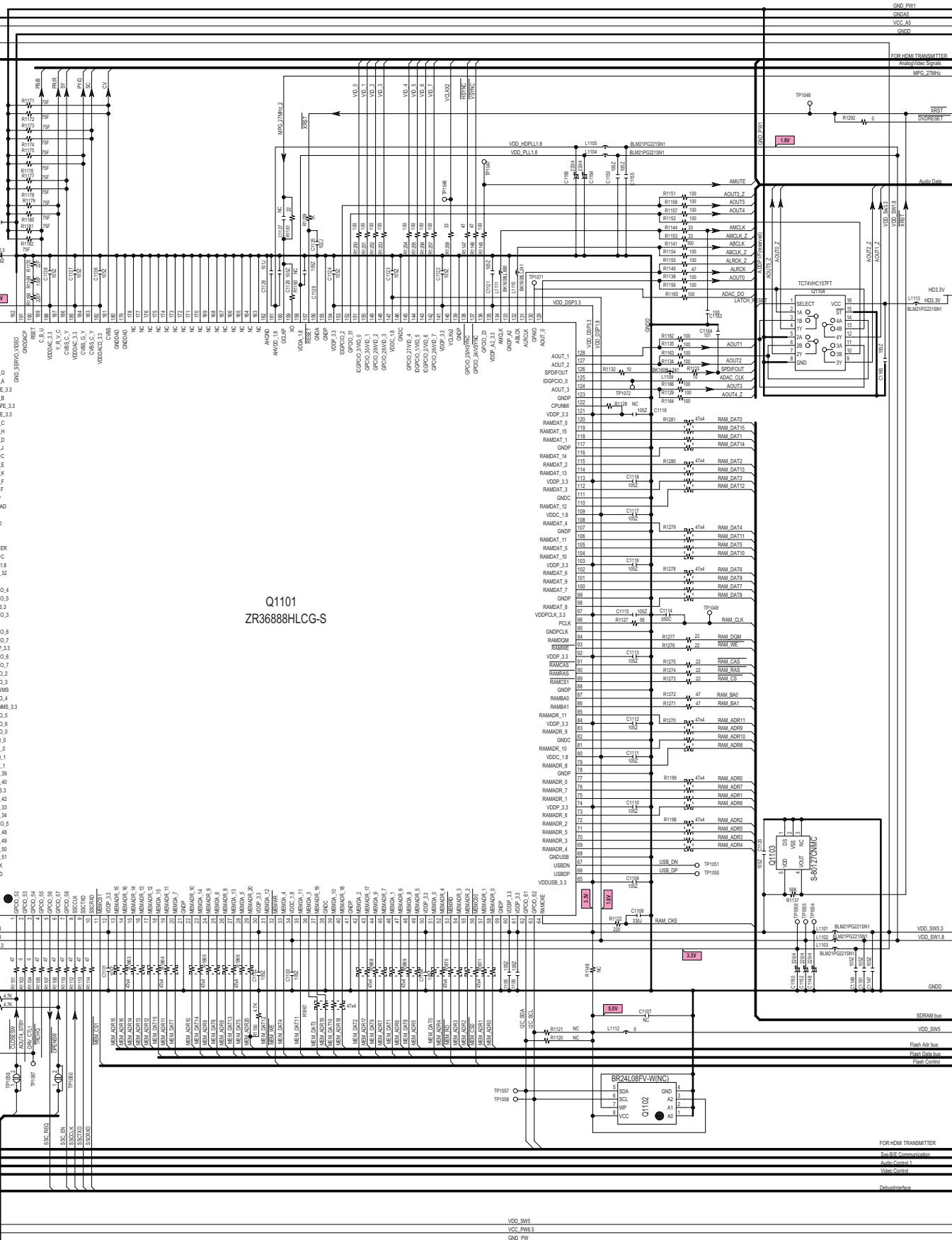

Q1101
ZR36888HLCG-S

SCHEMATIC DIAGRAM-2

DVD MAIN CIRCUIT PC BOARD-2 NADG-6934

1

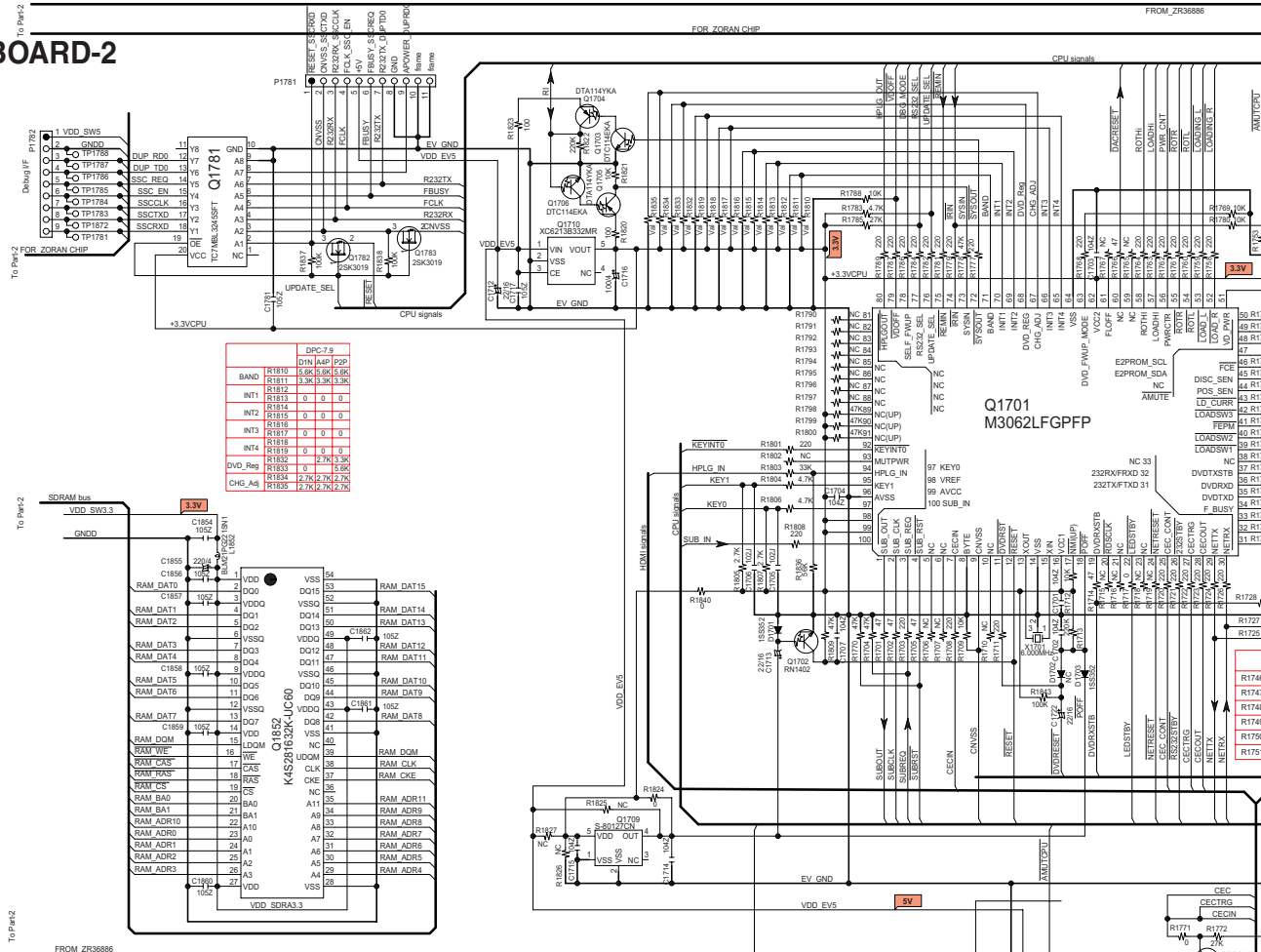

2

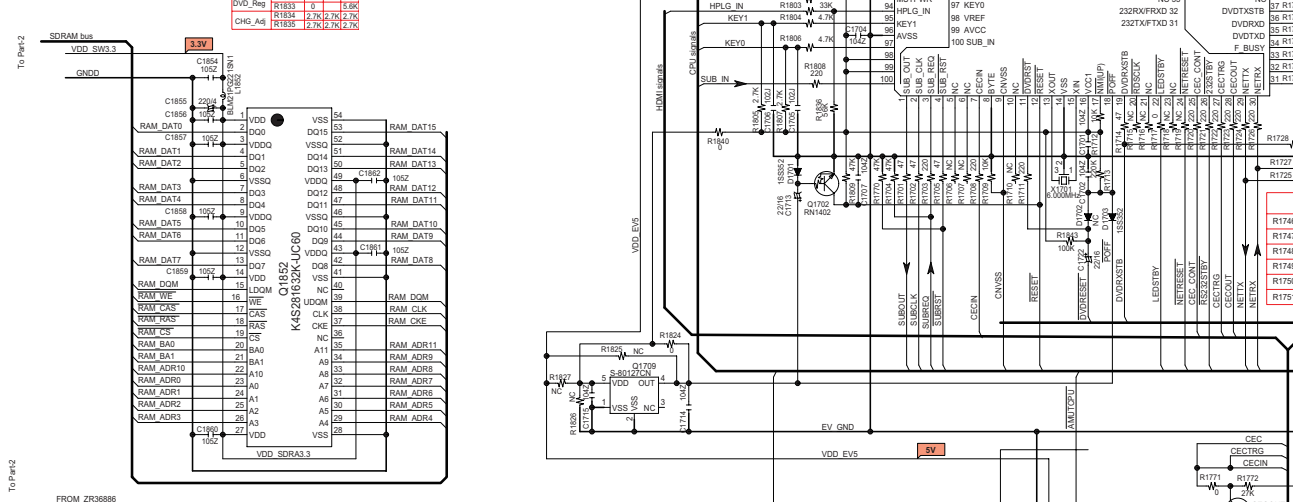

3

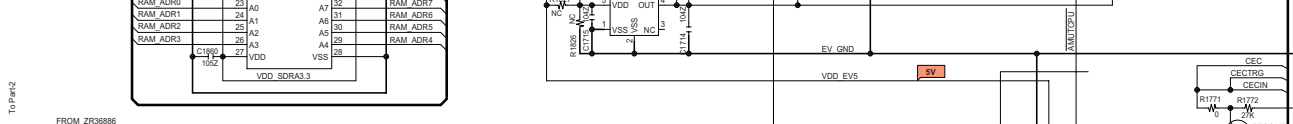

4

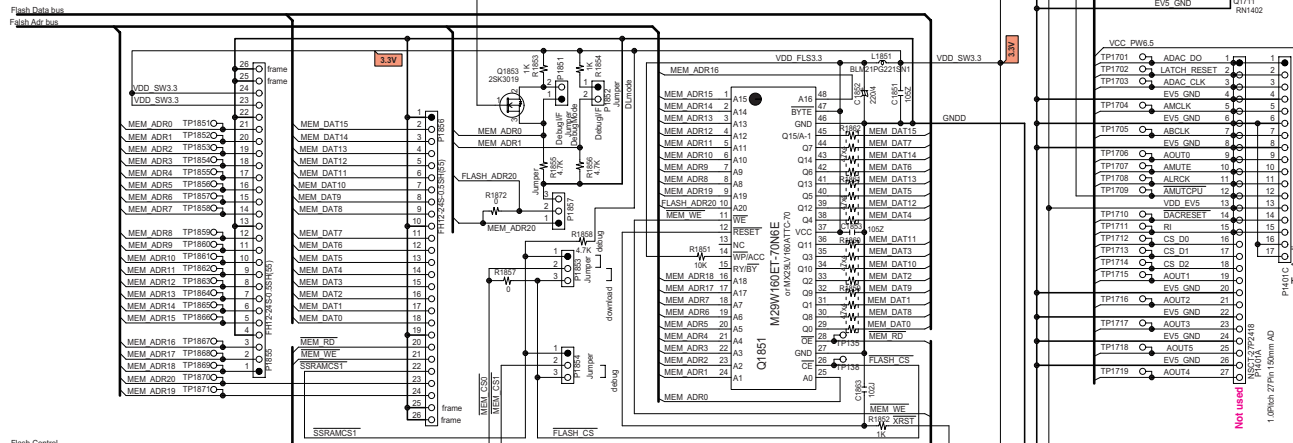

5

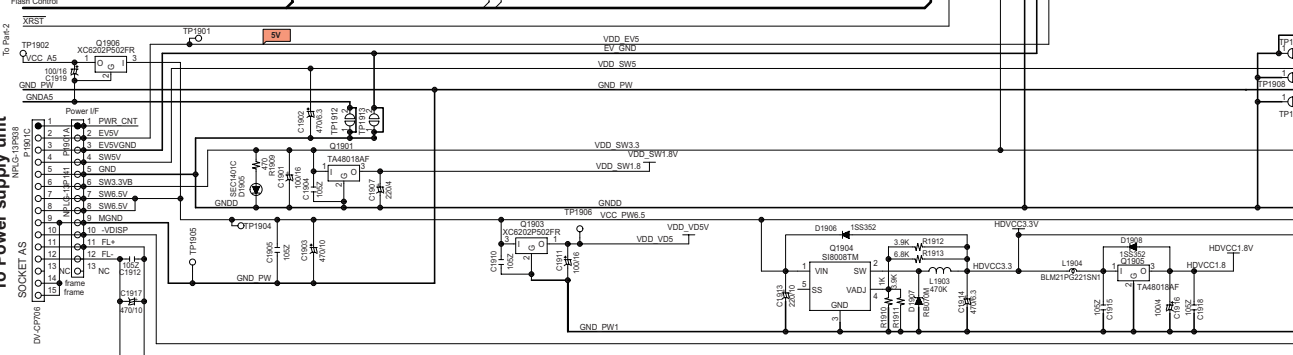

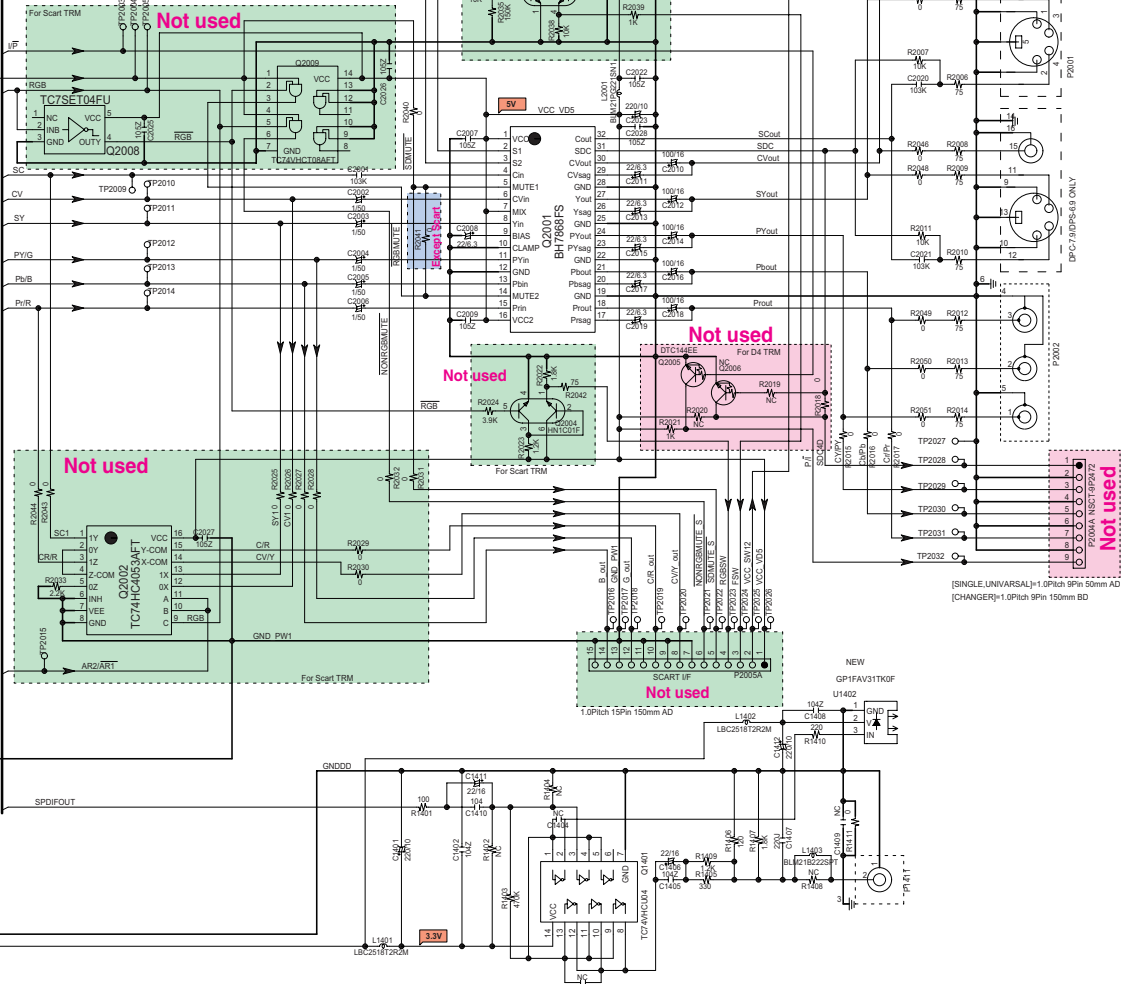
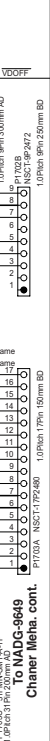
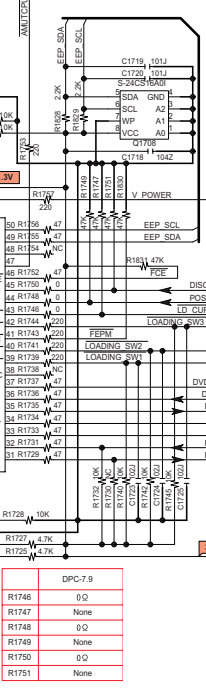
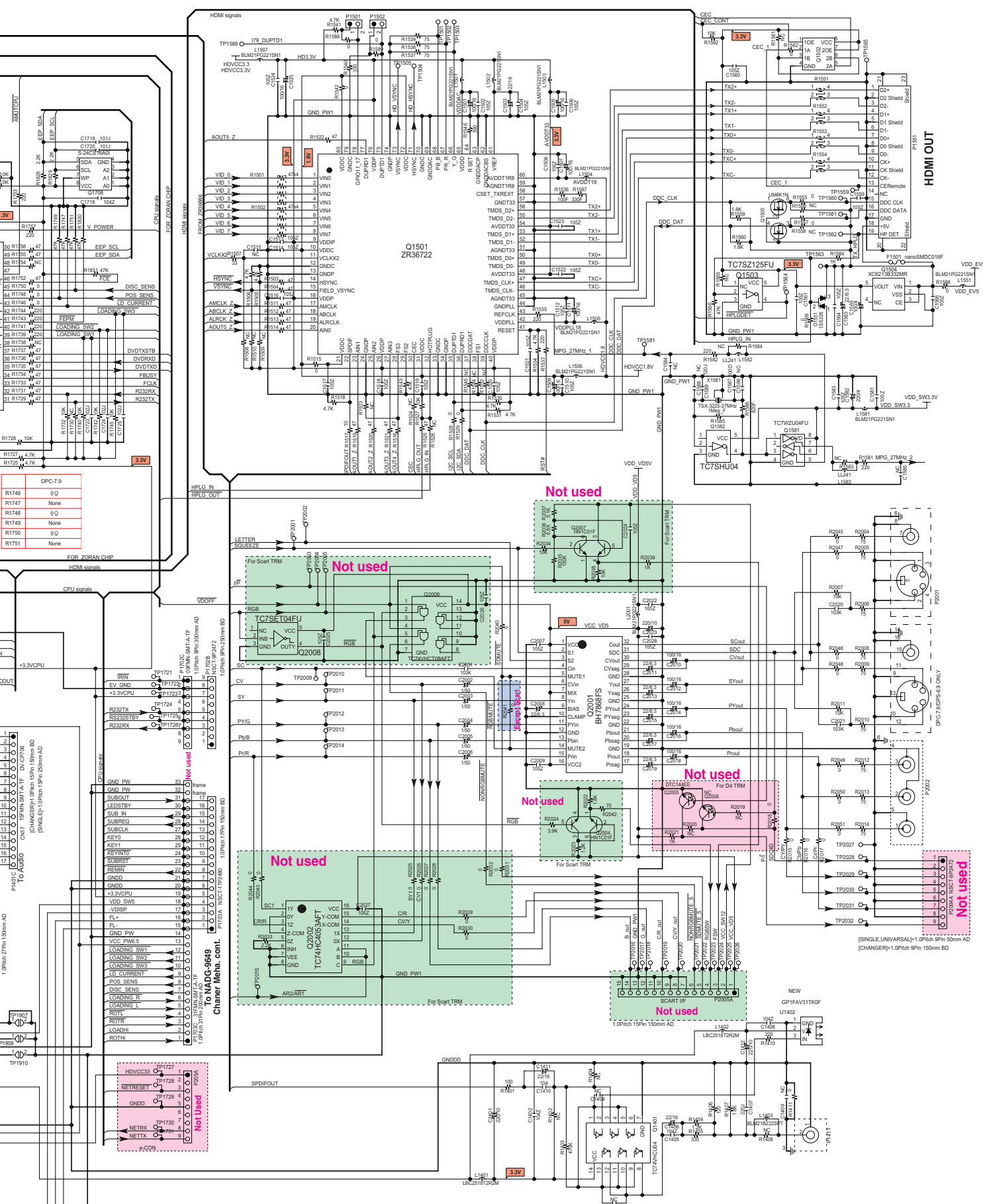

SCHEMATIC DIAGRAM-2

DVD MAIN CIRCUIT PC BOARD-2 NADG-9634

1

2

3

4

5

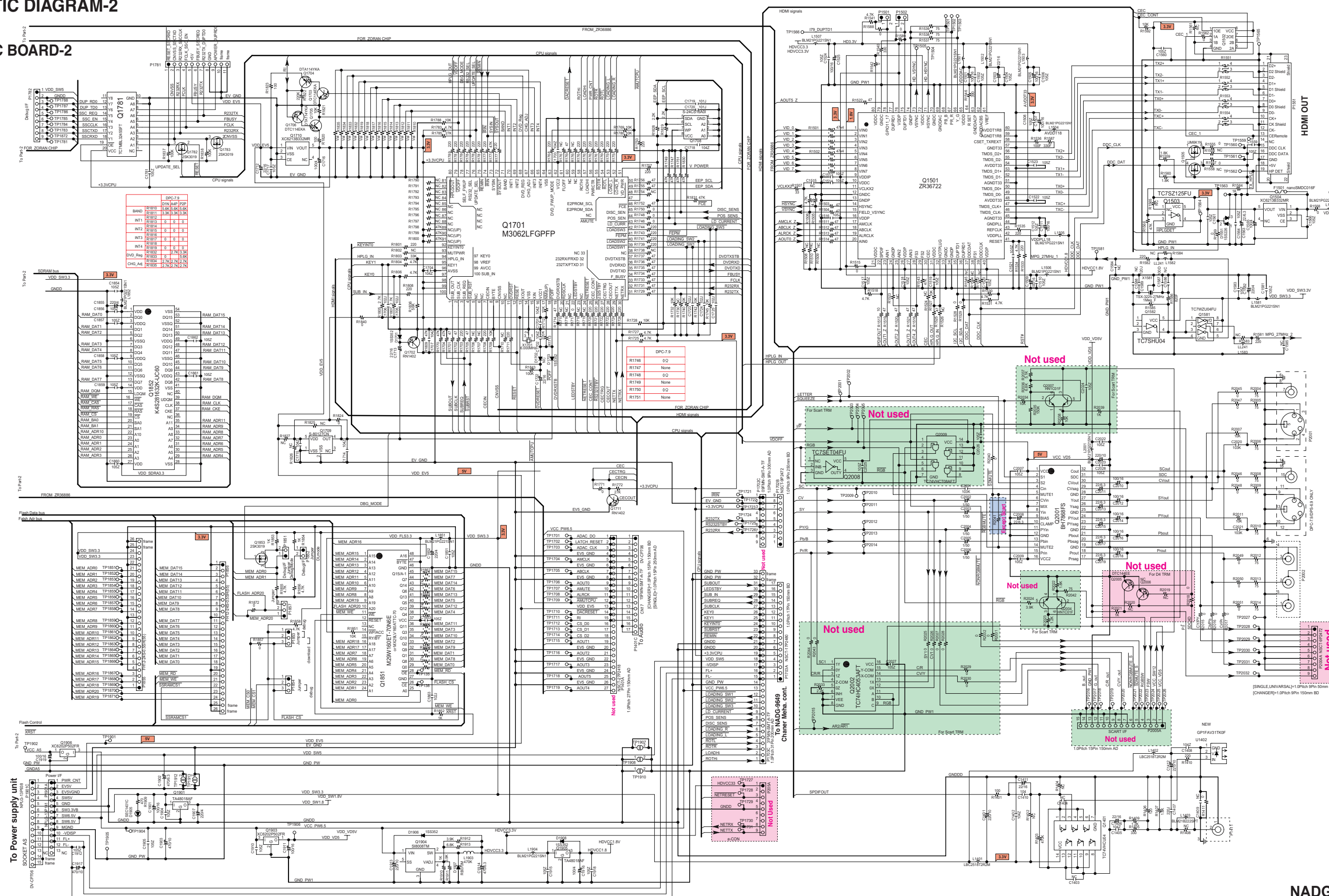

SCHEMATIC DIAGRAM-3

U12 DISC SENSOR PC BOARD

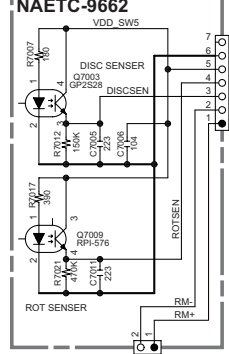

U10 ROULETTE MOTOR PC BOARD

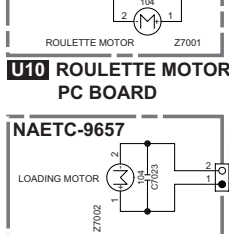

U09 LOADING MOTOR PC BOARD



U03 MECHA. CONTROL PC BOARD NADG-9649

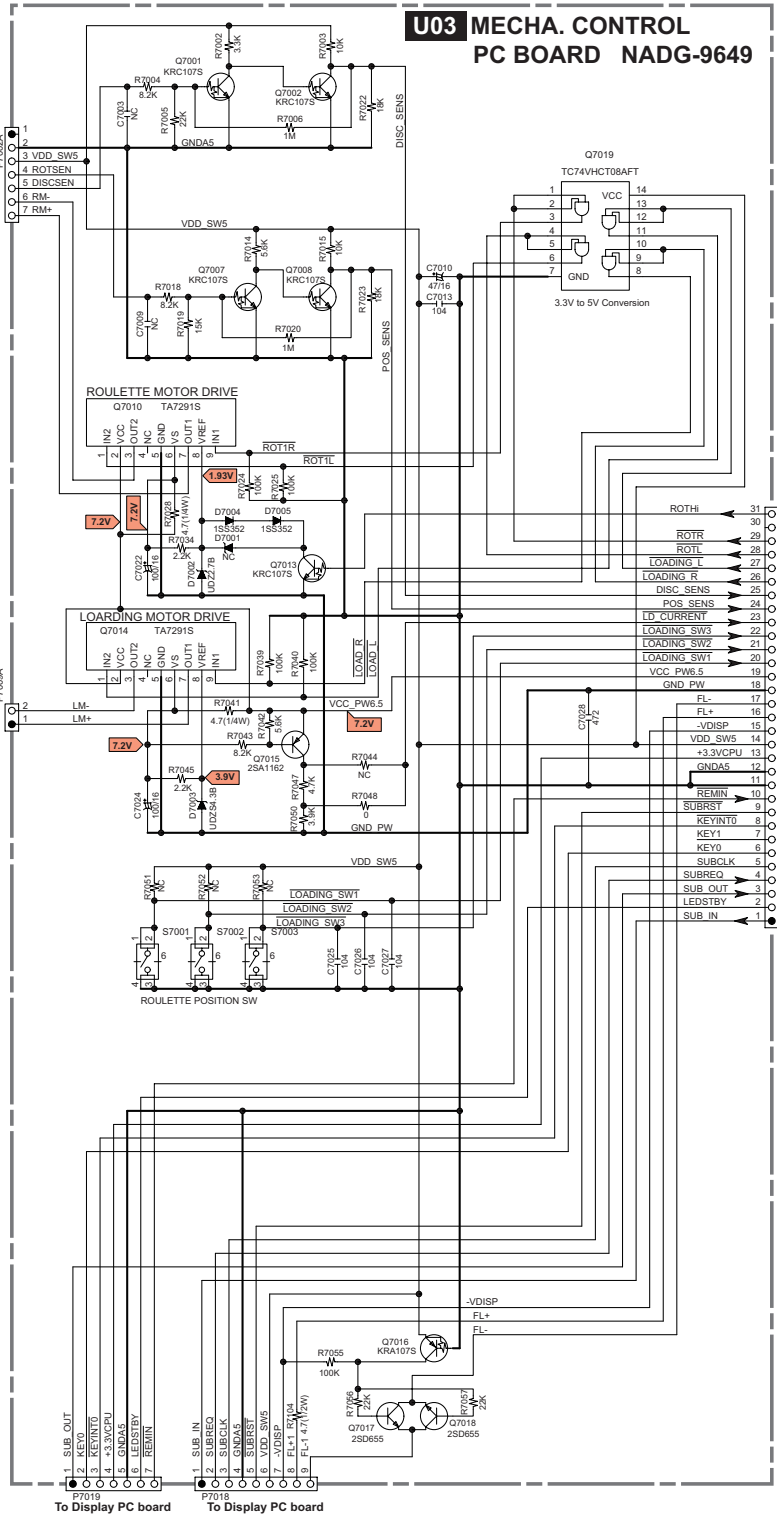

U13 RS-232C TERMINAL PC BOARD

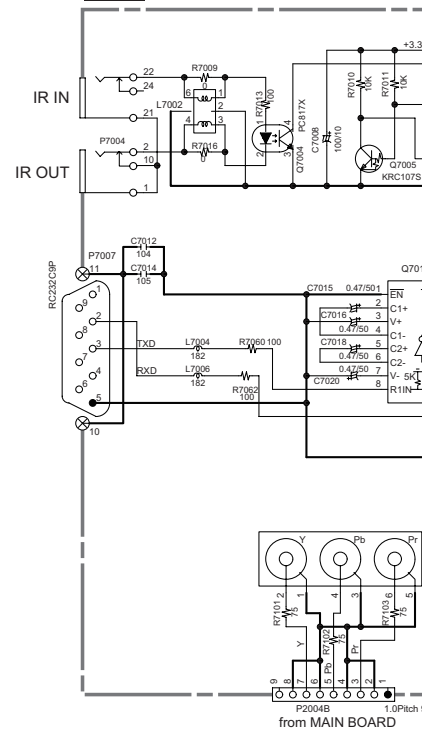

U04 AUDIO OUTPUT TERMINAL PC BOARD

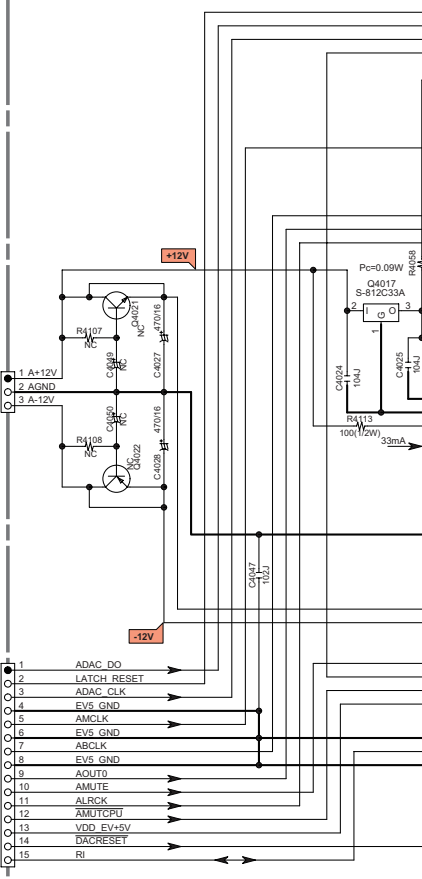

To Display PC board

from DVD Main PC Board

from Power supply unit

from DVD Main PC board

PC BOARD NAPS-9651

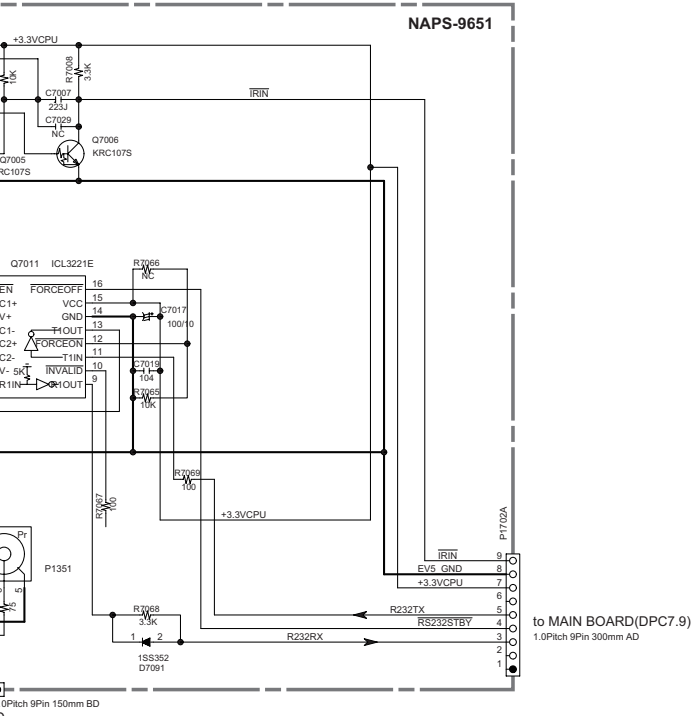

NOTE

- THE COMPONENTS IDENTIFIED BY MARK ARE CRITICAL FOR SAFETY. REPLACE ONLY WITH PART NUMBER SPECIFIED.
- VOLTAGE (MEASURED WITH VOLTMETER) IS DC VOLTAGE, (NO INPUT SIGNAL)
- ELECTROLYTIC CAPACITORS () ARE IN uF/WV.
- ALL CAPACITORS ARE IN pF/50WV UNLESS OTHERWISE NOTED.
EX) 030 = 3pF 330 = 33pF 331 = 330pF 333 = 0.033uF
- ALL RESISTORS ARE IN OHMS 1/4WATTS UNLESS OTHERWISE NOTED.
THE THICK LINES ON PC BOARD ARE THE PRINTING SIDE OF THE PARTS.
EX) PRINTING SIDE
- CIRCUIT IS SUBJECT TO CHANGE FOR IMPROVEMENT.



THIS SYMBOL LOCATED NEAR THE FUSE INDICATES THAT THE FUSE USED IS SLOW OPERATING TYPE FOR CONTINUED PROTECTION AGAINST FIRE HAZARD. REPLACE WITH SAME TYPE FUSE. FOR FUSE RATING REFER TO THE MAKING ADJACENT TO THE SYMBOL.

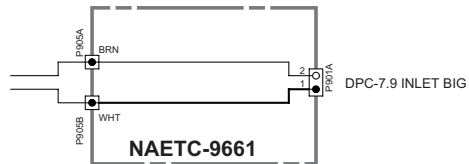

U11 AC INLET TERMINAL PC BOARD

PC BOARD NAAF-9650

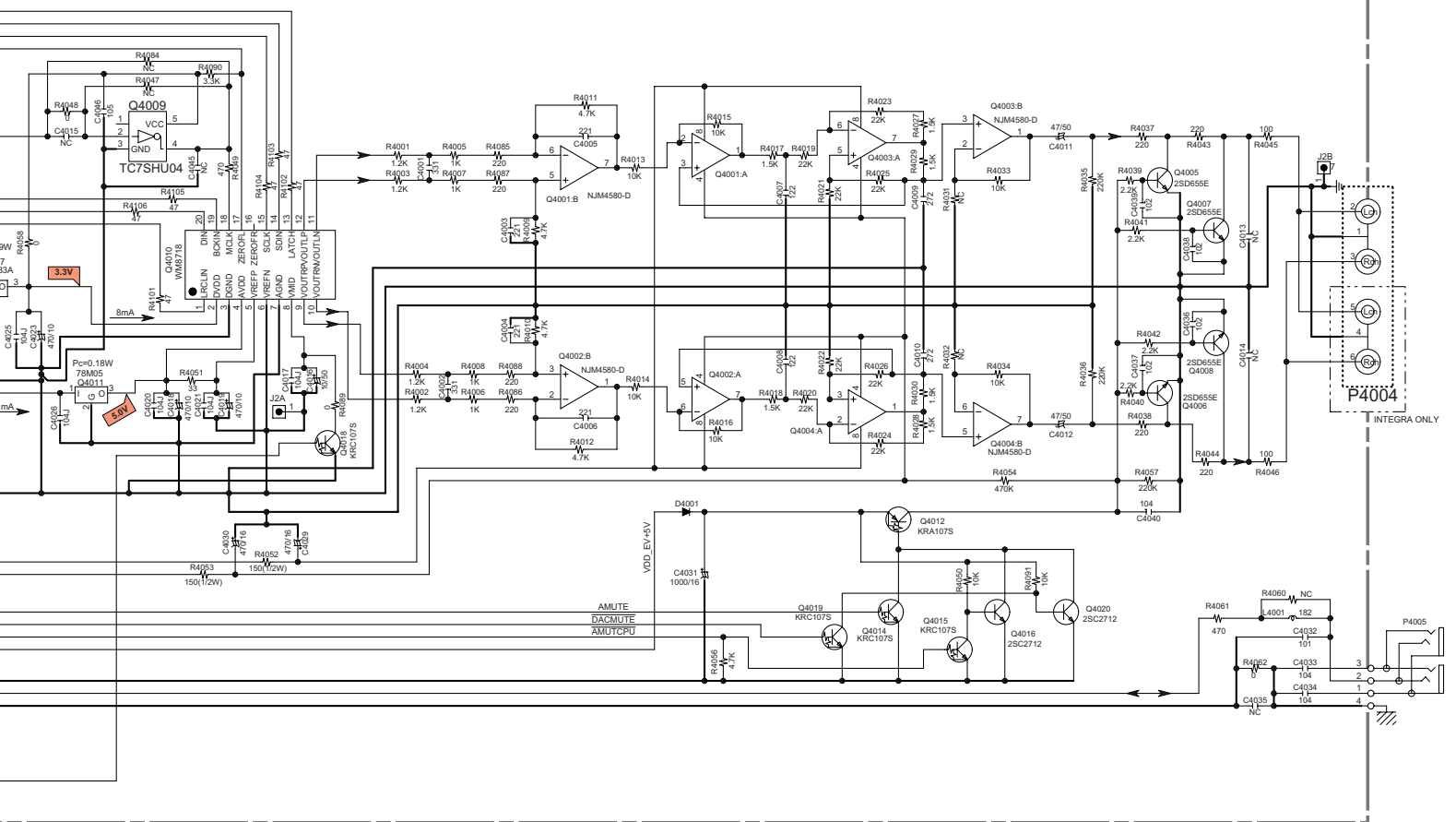

SCHEMATIC DIAGRAM-3

U12 DISC SENSOR PC BOARD
NAETC-9662

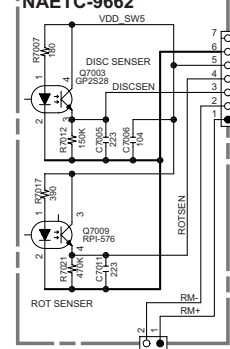

NAETC-9659

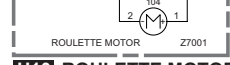

U10 ROULETTE MOTOR PC BOARD
NAETC-9657

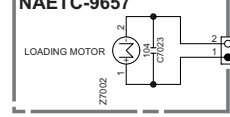

U09 LOADING MOTOR PC BOARD



U03 MECHA. CONTROL PC BOARD
NADG-9649

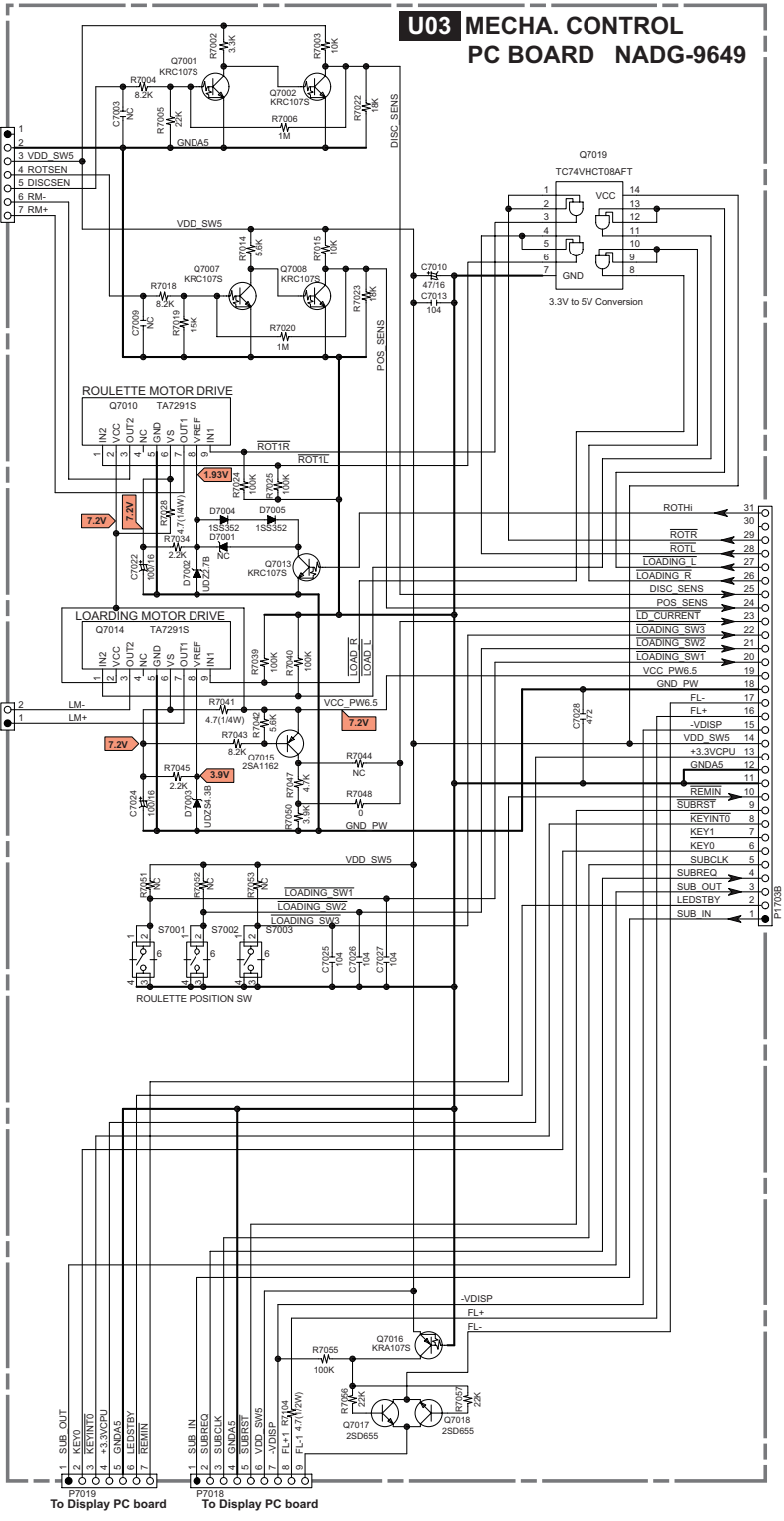

To Display PC board
To Display PC board

U13 RS-232C TERMINAL PC BOARD
NAPS-9651

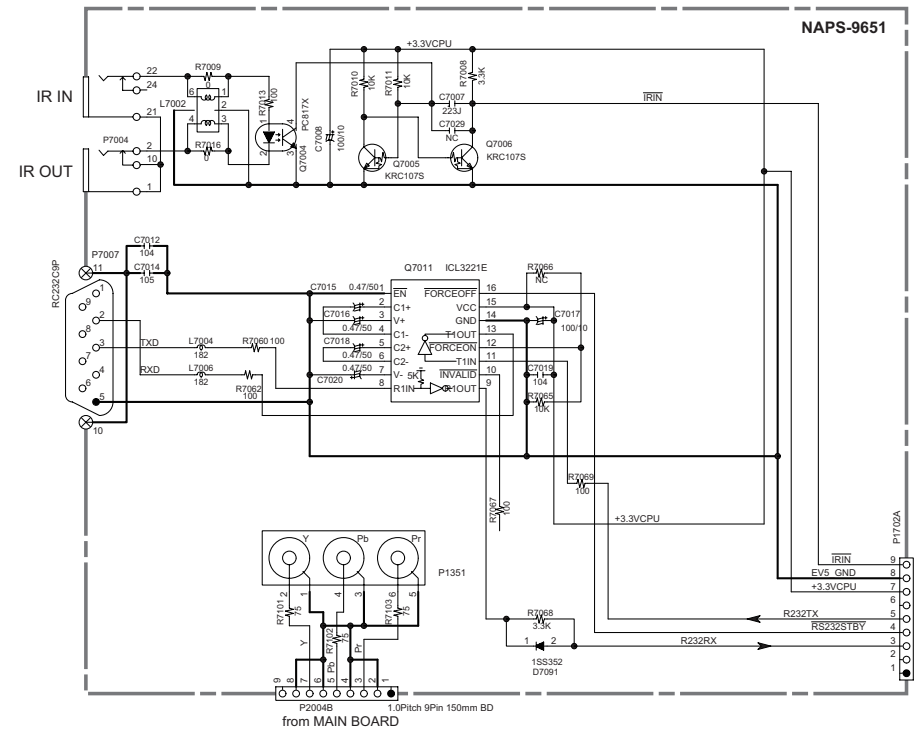

to MAIN BOARD(DPC7.9)
1.0Pitch 9Pin 300mm AD

NOTE

- THE COMPONENTS IDENTIFIED BY MARK Δ ARE CRITICAL FOR SAFETY. REPLACE ONLY WITH PART NUMBER SPECIFIED.
- VOLTAGE (MEASURED WITH VOLTMETER) \triangleleft IS DC VOLTAGE. (NO INPUT SIGNAL)
- ELECTROLYTIC CAPACITORS $\left(\begin{matrix} \text{---} \\ | \\ \text{---} \end{matrix} \right)$ ARE IN μF UNLESS OTHERWISE NOTED.
- ALL CAPACITORS ARE IN pF UNLESS OTHERWISE NOTED.
- EX) 030 = 30pF 330 = 330pF 511 = 510pF 333 = 0.033 μF
- ALL RESISTORS ARE IN OHMS 1/4WATTS UNLESS OTHERWISE NOTED.
- THE THICK LINES ON PC BOARD ARE THE PRINTING SIDE OF THE PARTS.
- EX) \square \square \square PRINTING SIDE
- CIRCUIT IS SUBJECT TO CHANGE FOR IMPROVEMENT.

THIS SYMBOL LOCATED NEAR THE FUSE INDICATES THAT THE FUSE USED IS SLOW OPERATING TYPE FOR CONTINUED PROTECTION AGAINST FIRE HAZARD. REPLACE WITH SAME TYPE FUSE. FOR FUSE RATING REFER TO THE MAKING ADJACENT TO THE SYMBOL.

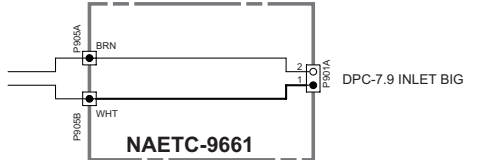

U11 AC INLET TERMINAL PC BOARD

U04 AUDIO OUTPUT TERMINAL PC BOARD
NAAF-9650

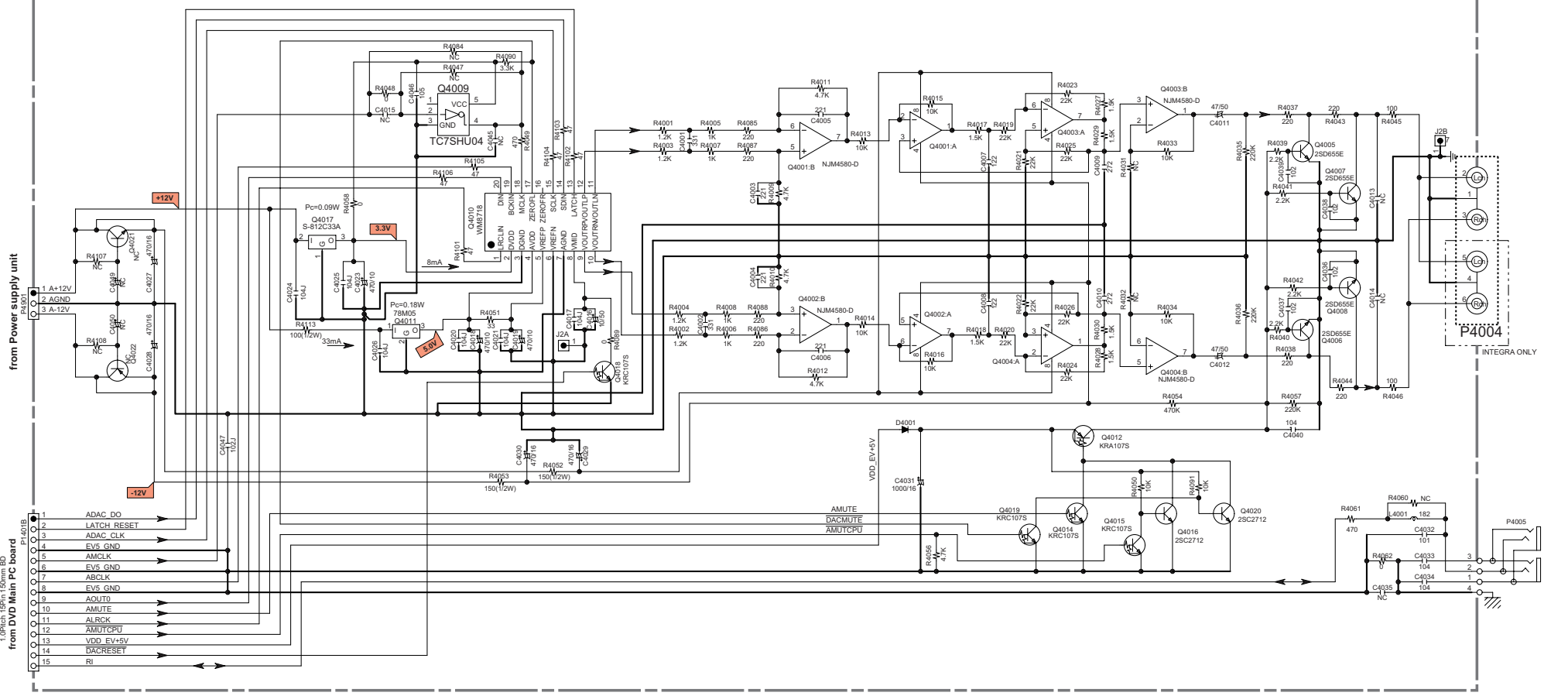

from Power supply unit

from DVD Main PC board
1.0Pitch 15Pin 150mm AD

INTEGRA ONLY

A

B

C

D

SHEMATIC DIAGRAM-4

U02 : DISPLAY CIRCUIT PC BOARD NADIS-9648

1

2

3

4

5

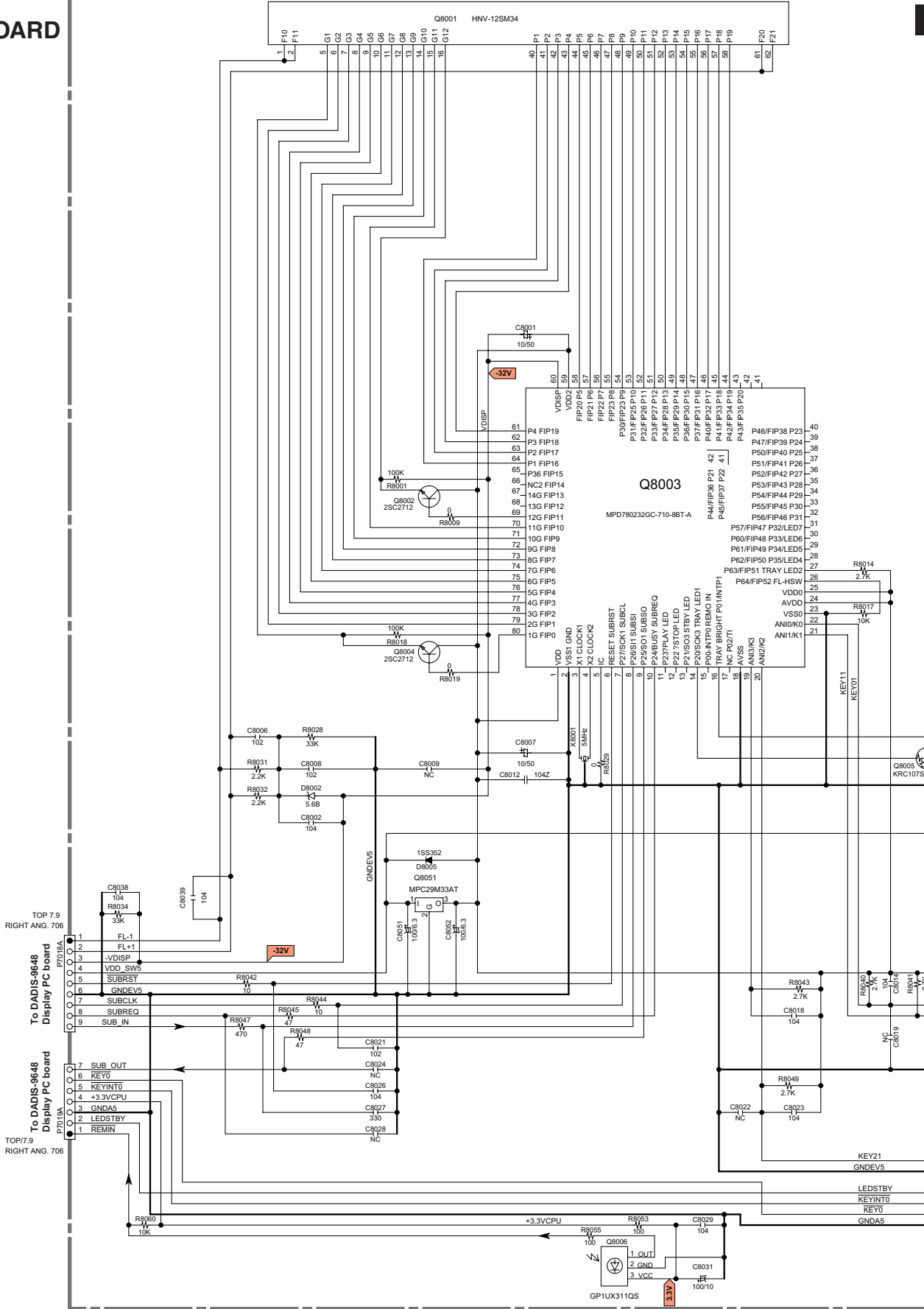

U

Q8005

KRC107S

R8040

R8041

R8042

R8043

R8044

R8045

R8046

R8047

R8048

R8049

R8050

R8051

R8052

R8053

R8054

U02

NADIS-9648

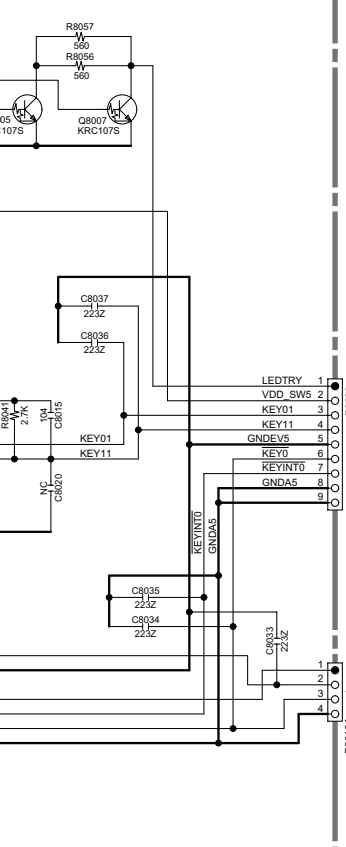

U07 DISC OPERATION PC BOARD NASW-9655

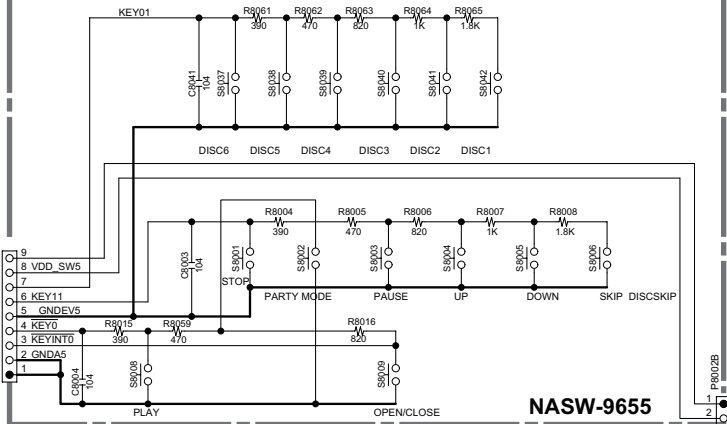

NASW-9652

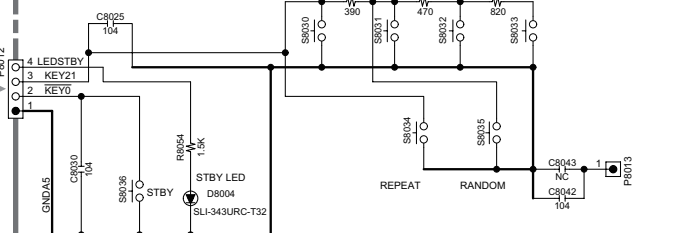

U05 STANDBY SWITCH PC BOARD

U08 ILLUMINATION PC BOARD

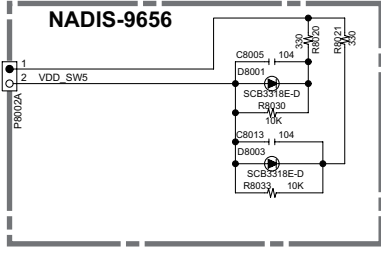

A B C D E F G H

SHEMATIC DIAGRAM-4

U02 : DISPLAY CIRCUIT PC BOARD NADIS-9648

1

2

3

4

5

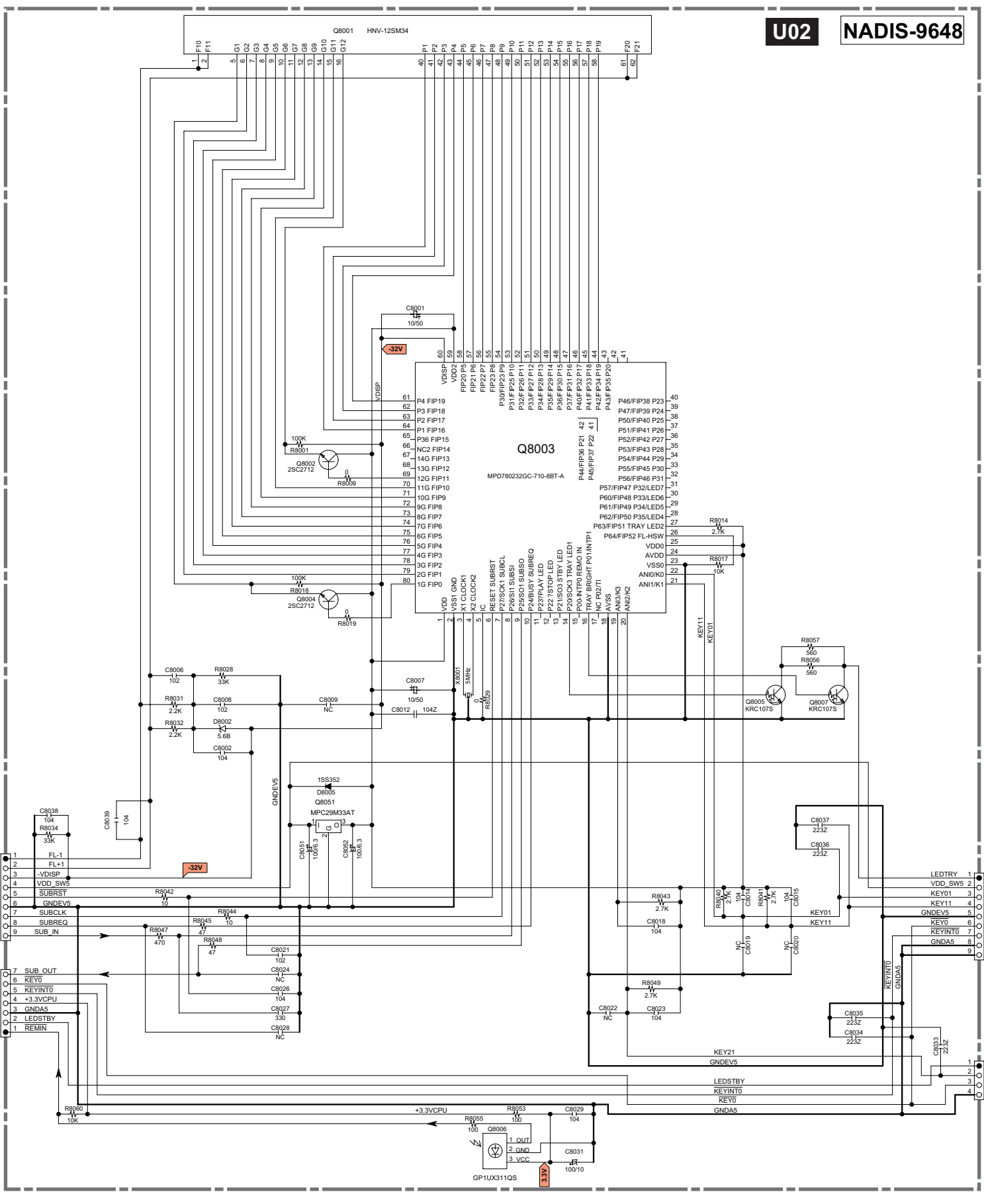

U02 NADIS-9648

U07 DISC OPERATION PC BOARD NASW-9655

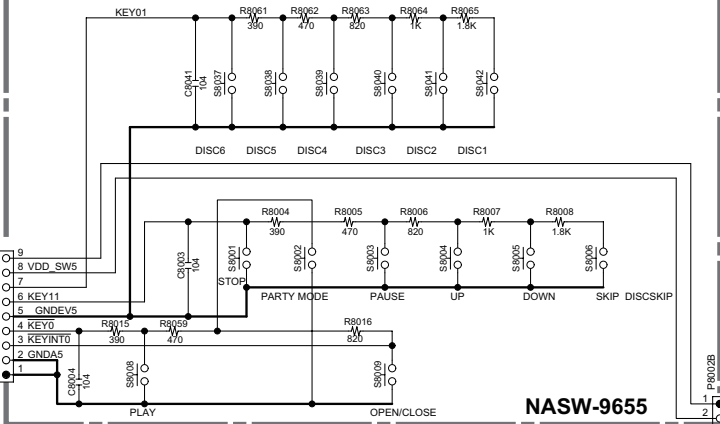

U03 ILLUMINATION PC BOARD NADIS-9656

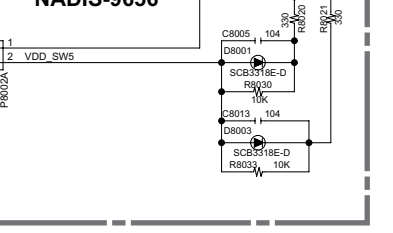

NASW-9652

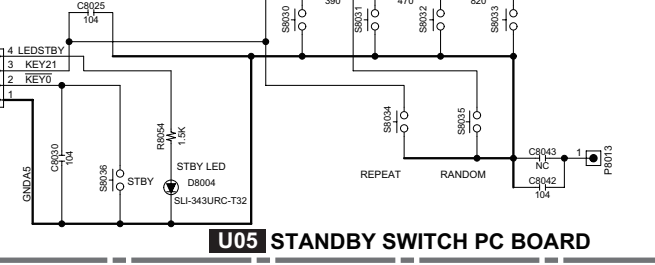

U05 STANDBY SWITCH PC BOARD

A

B

C

D

E

SCHEMATIC DIAGRAM-5

POWER SUPPLY UNIT

U20 : NGPS-0074-100-120V (MUD)

NGPS-0075-100-240V (MUA/MUP)

Color is MUA and MUP

1

2

3

4

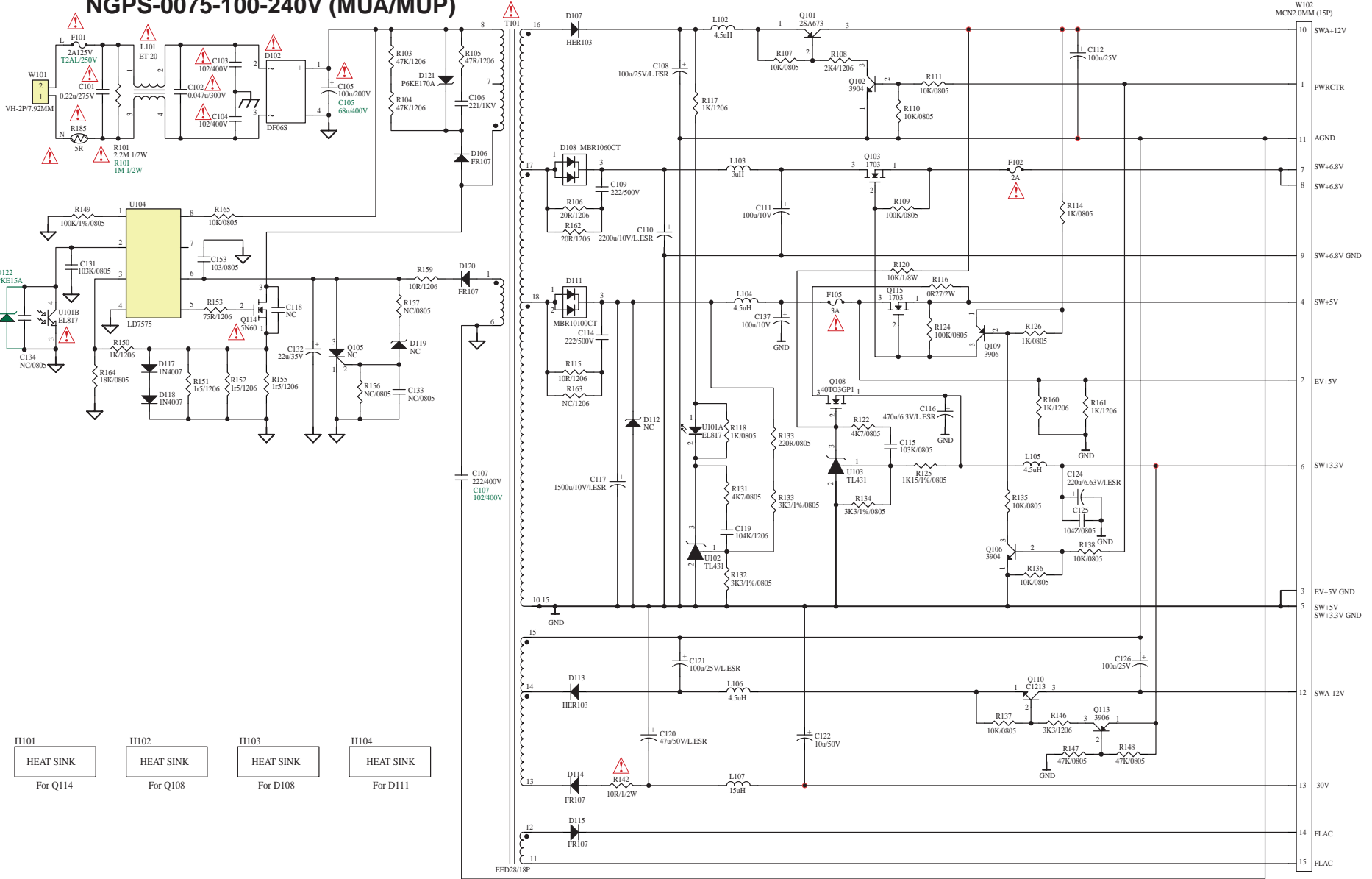

- H101 HEAT SINK For Q114
- H102 HEAT SINK For Q108
- H103 HEAT SINK For D108
- H104 HEAT SINK For D111

PACKING VIEW

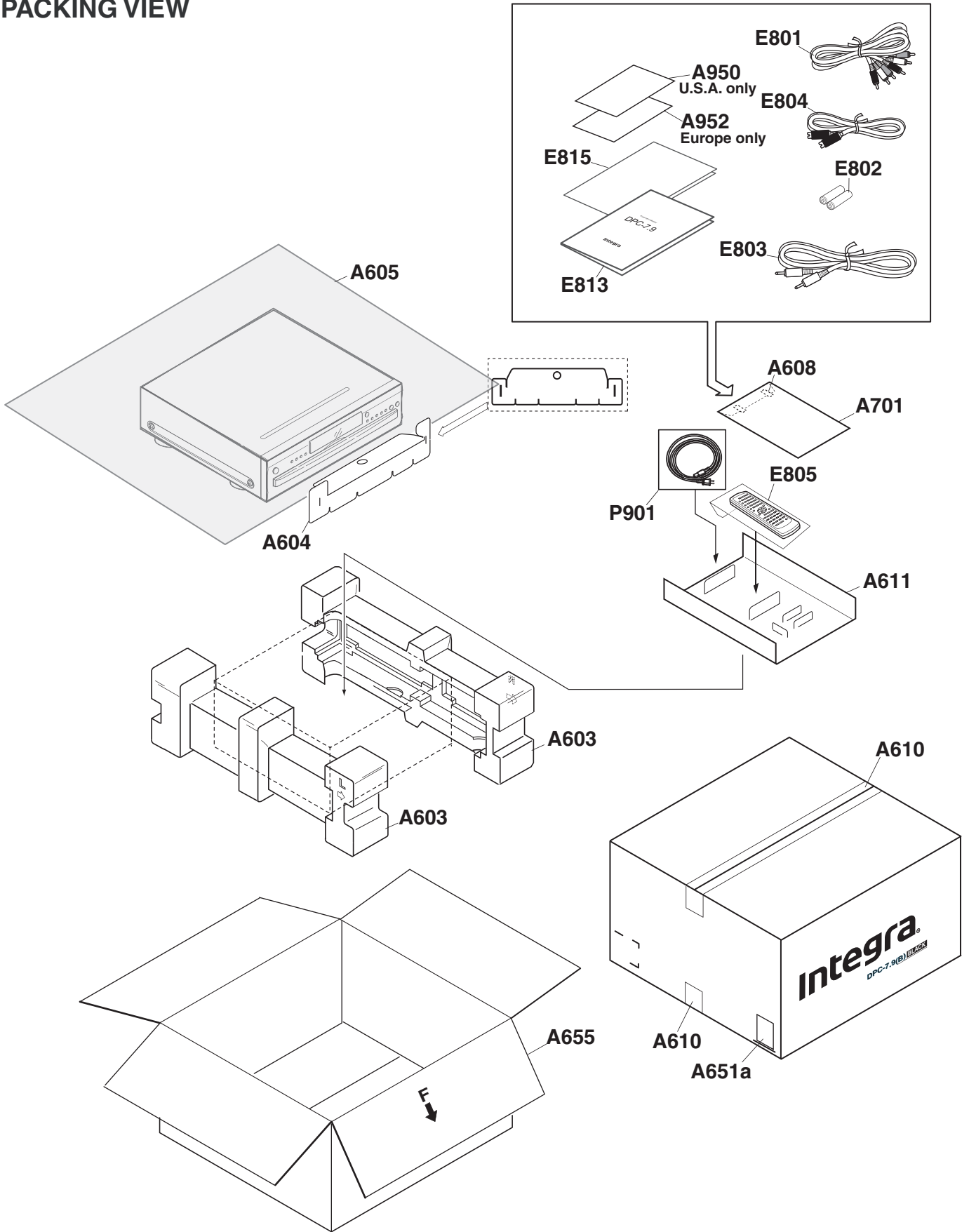

PARTS LIST

DPC-7.9

<Note>

Parts marked by "NSP" are generally unavailable because they are not in our Master Spare Parts List.

<NOTE>

! : Safety part

<MDD>: North American model

<MUA> : Australian model

<MUP> : European model

REF. NO.	PART NAME	DESCRIPTION	PART NO.	REMARKS
A001	F BRACKET	--	27111317B	
A002	KNOB	(STANDBY)	28325756	
A003	BRACKET	--	27130903A	
A005	CLIP	CS-1U	27255004	A001
A006	SCREW	3TTB+8B(3CM)	838130088GR	A003x4 A005x1 PWBx6 FLx2
A007	CUSHION	--	28141597-1	N
A009	IB CUSHION	W15*3t TAPE	28141585	FLx2:0.012:MT
A017	SCREW	3TTB+8B(3CM)	838130088GR	A001x2
A019	TAPE	TAPE(CLOTH-8U)	29110082	PWB(MAIN)0.05,PWB(LED)0.05:0.1 :MT
A024	WIRE TIE	BSK-1	260208	F BRAX2,CHASSISx3
A025	TAPE	TAPE(CLOTH-16U)	29110083	A100:0.3:MT
A026	ISO PLT	--	28175293-1	
A027	P RIVET	P-3055B-8L	880048	
A028	DOOR	(TRAY)	28148537C	
A032	SHEET	(F)	29095947-1	N A001
A040	SCREW	3TTW+8B(3BC)	831430088GR	MECHAx8
A053	REAR PANEL	DPC-7.9DD1N	27123957	N <MDD>
A053	REAR PANEL	DPC-7.9UA4P	27123958	<MUA>
A053	REAR PANEL	DPC-7.9UP2P	27123959	N <MUP>
A054	SCREW	3TTB+8B(3BC)	838430088GR	A053x14
A055	SCREW	4TTB+8C(3BC)	838440089GR	A053x2 AC INLET
A056	SCREW	3P+6FN(3BC)	82143006GR	A053x1 HDMI
A057	LABEL	(DVD3)	29364728	
	CHASSIS	--	27100478B	NSP
A101	HOLDER	KGLS-10RT	27190428A	
A102	HOLDER	KGLS-12RT	27190266	
A110	SCREW	3P+6FN(3BC)	82143006GR	PWBx2

A120	BOTTOM LEG	.DV-SP504	27175433	
A121	CUSHION	--	28141664	LEGx2
A122	SCREW	3TTB+8B(3CM)	838130088GR	LEGx4
A214	COVER	DPC-7.9(B)	28184968-1AZ	N Not bent
A214	COVER	DPC-7.9(B)	28184968-1A	N Bent
A215	SCREW	3TTB+8B(3BC)	838430088GR	A214x8
A217	F PANEL	DPC-7.9(B)M	27213185	N
A218	GUIDE	(KNOB)	27262697	
A220	FACET	--	28198905	
A221	FACET	(L)	28198961A	
A223	CLEAR PLT	DPC-7.9	28192222	N
A224	B PLATE	--	28133409GR	
A226	BADGE	--	28135278	
A230	SCREW	3TTB+8B(3BC)	838430088GR	A217x4
E811	CRIMP AS	CRIMP AS TCW21M	2061112060UL	
E811A	SCREW	3TTB+8B(3CM)	838130088GR	
F101	FUSE	2A-UL/T-233	252320GR	! <MDD>
F101	FUSE	2A-SE-EAK FUSE	252074GR	! <MUA><MUP>
P1002	FFC	NCFC5-242012	204C242012	
P1304	FFC	NCFC5-091512	2045091512	N
P1401	FFC	NCFC5-151512	2045151512	
P1702	FFC	NCFC5-093022	2045093022	N
P1703	FFC	NCFC5-312022	2045312022	
P1901B	SOCKET AS	NSAS-30P1786	2009991146UL	N
P7002	FFC	NCFC3-07037	204307037	
U01	DVD Main circuit PC board a'ssy	NADG-9634-1C	1H554534-1C	N <MDD>
U01	DVD Main circuit PC board a'ssy	NADG-9634-1D	1H554534-1D	N <MUA>
U01	DVD Main circuit PC board a'ssy	NADG-9634-1T	1H554534-1T	N <MUP>
U02	Display circuit PC board a'ssy	NADIS-9648-1B	1H554548-1B	N <MDD><MUA><MUP>
U03	Mecha. Control PC board assy	NADG-9649-1B	1H554549-1B	N <MDD><MUA><MUP>
U04	Audio output terminal PC board assy	NAAF-9650-1B	1H554550-1B	N <MDD><MUA><MUP>
U05	Standby switch PC board assy	NASW-6952-1B	1H554552-1B	N <MDD><MUA><MUP>
U07	Disc operation PC board assy	NASW-9655-1B	1H554555-1B	N <MDD><MUA><MUP>
U08	Illumination PC board assy	NADIS-9656-1B	1H554556-1B	N <MDD><MUA><MUP>
U09	Loading motor PC board assy	NAETC-9657-1B	1H554557-1B	N <MDD><MUA><MUP>

U10	Roulette motor PC board assy	NAETC-9659-1B	1H554559-1B	N <MDD><MUA><MUP>
U11	AC Inlet terminal PC board assy	NAETC-9661-1B	1H554561-1B	N <MDD><MUA><MUP>
U12	DISC Sensor PC board assy	NAETC-9662-1B	1H554562-1B	N <MDD><MUA><MUP>
U13	RS-232C terminal PC board assy	NAPS-9651-1B	1H554551-1B	N <MDD><MUA><MUP>
U14	Connection PC board	NAETC-9660-1B	1H554560-1B	N <MDD><MUA><MUP>
U20	Power supply unit	NGPS-0075-100-240V	24150075A	! <MUA><MUP>
U20	Power supply unit	NGPS-0074-100-120V	24150074B	! <MDD>
F102	Quick action micro fuse	MQ2A/125V	OP66	!
F105	Quick action micro fuse	MQ3A/125V	OP67	!

CHANGER MECHANICAL PARTS

M001	RAIL	--	24840172B	MP010:
M002	Loading motor assy	M002+M003	1H498602A	
M002	MOTOR	CCM07B-045R1-1A	--	NSP
M003	PULLEY	.	--	NSP
M003 or	PULLEY	.	--	NSP
M004	SCREW	2.6P+4FN	82112604	M001*2
M005	RBR BELT	DVCP701	24816039	
M006	GEAR	(PULLEY)	24810085	
M007	GEAR	(A)	24810086	
M008	GEAR	(MAIN)	24810087B	
M009	GEAR	(CAM)	24810088	
M010	SCREW	3*8*w11	801633	M006*1,M008*1,M009*1
M011	HOLDER	KGLS-8RT	27190503A	
M012	DVD Mechanism a'ssy	TDT-2100SF-O2	24801035	
M012a	DAMPER-IDLE	C2G083	--	NSP
M012b	SCW-DAMPER-CR3	C1H012	--	NSP
M012c	CLAMPER-H	A7G202	--	NSP
M012d	CLUMPER-L	A7G203	--	NSP
M012e	CLAMP-T-M12H	A7P085	--	NSP
M013	CHASSIS	(SUB)	24802059	
M014	SCREW	3TTB+8B(3CM)	838130088GR	PCB*4
M015	CLIP	CS-1U	27255004-1	
M015 or	CLIP	CS-1U	27255004	
M016	SCREW	3TTB+8B(3CM)	838130088GR	M015*1

M018	CUSHION	--	28141708-1	M001*2
M018 or	CUSHION	--	28141708	M001*2
M030	ARM	--	24814027A	
M031	CUSHION	--	28141561-1	M030*1
M031 or	CUSHION	--	28141561	M030*1
M032	SCREW	3TTB+8B(3CM)	838130088GR	M030*1
M033	TAPE	TAPE(CLOTH-16U)	29110083	0.05:MT
M050	TRAY	--	24840158I	
M051	CUSHION	--	28141561-1	
M051 or	CUSHION	--	28141561	
M052	BRACKET AS	(M)	24840160B	
M052a	BRACKET	(M)	--	NSP
M052b	SHAFT	(M)	--	NSP
M053	Roulette motor assy	M053+M054+M055	1H498603	
M053	MOTOR	PWN10EA02D	--	NSP
M054	WASHER	0.5t*2.1*6	--	NSP
M054 or	WASHER	0.5t*2.1*6	--	NSP
M055	GEAR	(WORM)	--	NSP
M055	GEAR	(WORM)	--	NSP
M056	SCREW	2P+3FN(3CM)	82112003GR	M052*2
M057	GEAR	(WHEEL)	24810089	
M058	WASHER	(B)	24834040	M057*1
M059	SCREW	3TTB+8B(3CM)	838130088GR	M052*2,PCB*1
M060	ROLLER	DVCP701	24840162	M050*4
M061	ROULETTE	(HS)	24840174	
M062	SCREW	3*8*w11	801633	M061*1

PACKING PARTS LIST**DPC-7.9**

REF. NO.	PART NAME	DESCRIPTION	PART NO.	REMARKS
A603	PAD	AS	29092185-1	N
A603a	PAD	(L)	29092186-1	N
A603b	PAD	(R)	29092187-1	N
A604	SHEET	(DR)	29095795	
A605	SHEET	--	29095847	
A608	TAPE	(SEROHAN)NITTO NO.29	29110149	0.3m

A610	PP TAPE	W50 SBT-70	29110200	1.5m
A611	SHEET	(PAD)	29096050-1	
A651a	UPC LABEL	DPC-7.9(B)	29390565	<MDD>
A651a	EAN LABEL	DPC-7.9(B)MUA	29390581	N <MUA>
A651a	EAN LABEL	DPC-7.9(B)MUP	29390582	N <MUP>
A655	CARTON	DPC-7.9MDD	29054960	<MDD>
A655	CARTON	DPC-7.9MUA	29054961	N <MUA>
A655	CARTON	DPC-7.9MUP	29054962	N <MUP>
A701	POLY BAG	w250xd350	29100250A	
A950	WRNTY CARD	(INTEGRA)	29365136	<MDD>
A952	INST SHEET	WEEE	29355537	<MUP>
E801	PIN CORD AS	RCA3P(YWR)	2010379	
E801 or	PIN CORD AS	RCA-3P(YWR)	2010359TAIDA	
E802	BATTERY	R6/AA(UM-3)	3010194	
E802 or	BATTERY	R6/AA(UM-3)	3010054	
E803	PLUG CORD	3.5-MINI PLUG (RI)	2010200	
E804	CORD AS	RCA-1P(O)	2010424	
E805	REMO CON	RC-656DV	24140656	
E813	INS MANUAL	En(DPC7.9)	29344789	N
E815	INS MANUAL	En(DPC7.9)HDMI	29344791	N
P901	AC CORD	AS-UC-2	253352ATES	! <MDD>
P901	AC CORD	AS-SAA	253391VOL	! <MUA>
P901	AC CORD	AS-CEE-3	253298VOL	! <MUP>

PRITED CIRCUIT BOARD PARTS LIST

DPC-7.9

U01 :	DVD Main circuit PC board NADG-9634-1C	1H554534-1C	N	<MDD>
U01 :	DVD Main circuit PC board NADG-9634-1D	1H554534-1D	N	<MUA>
U01 :	DVD Main circuit PC board NADG-9634-1T	1H554534-1T	N	<MUP>

CIRCUIT NO	PART NAME	DESCRIPTION	PART NO.	REMARKS
C1001	CHIP ELECT C	CEWX4V-220M	3981G2217R2	
C1002	CHIP ELECT C	CEWX4V-47M	3981G4707R2	
C1003	CHIP ELECT C	CEWX4V-47M	3981G4707R2	
C1004	C-CERA C	CK725F1A-105Z1	332181050R1	

C1005	C-CERA C	CK725F1A-105Z1	332181050R1
C1006	C-CERA C	CK725F1A-105Z1	332181050R1
C1007	C-CERA C	CK725F1A-105Z1	332181050R1
C1008	C-CERA C	CC725CH1H-102J1	342101024R1
C1009	C-CERA C	CC725CH1H-330J1	342103304R1
C1010	C-CERA C	CC725CH1H-330J1	342103304R1
C1011	C-CERA C	CC725CH1H-330J1	342103304R1
C1012	C-CERA C	CC725CH1H-330J1	342103304R1
C1013	C-CERA C	CC725CH1H-102J1	342101024R1
C1014	C-CERA C	CC725CH1H-102J1	342101024R1
C1015	C-CERA C	CC725CH1H-330J1	342103304R1
C1016	C-CERA C	CC725CH1H-330J1	342103304R1
C1017	C-CERA C	CK725B1C-104K1	332121045R1
C1018	C-CERA C	CC725CH1H-330J1	342103304R1
C1019	C-CERA C	CC725CH1H-330J1	342103304R1
C1020	C-CERA C	CK725F1A-105Z1	332181050R1
C1021	CHIP ELECT C	CEWX16V-100M	398141017R2
C1022	C-CERA C	CK725F1A-105Z1	332181050R1
C1023	C-CERA C	CK725F1A-105Z1	332181050R1
C1024	CHIP ELECT C	CEWX50V-1M	398180107R2
C1025	CHIP ELECT C	CEWX16V-100M	398141017R2
C1026	C-CERA C	CK725F1A-105Z1	332181050R1
C1027	CHIP ELECT C	CEWX6.3V-330M	398123317R2
C1028	C-CERA C	CK725F1A-105Z1	332181050R1
C1029	CHIP ELECT C	CEWX4V-220M	3981G2217R2
C1030	C-CERA C	CK725F1A-105Z1	332181050R1
C1031	C-CERA C	CC725CH1H-102J1	342101024R1
C1032	C-CERA C	CK725B1C-104K1	332121045R1
C1033	C-CERA C	CK725B1C-104K1	332121045R1
C1101	C-CERA C	CK725F1A-105Z1	332181050R1
C1102	C-CERA C	CK725F1A-105Z1	332181050R1
C1103	C-CERA C	CK725F1A-105Z1	332181050R1
C1104	C-CERA C	CK725F1A-105Z1	332181050R1
C1105	C-CERA C	CK725F1A-105Z1	332181050R1
C1106	C-CERA C	CK725F1A-105Z1	332181050R1

C1108	C-CERA C	CC725CH1H-330J1	342103304R1
C1109	C-CERA C	CK725F1A-105Z1	332181050R1
C1110	C-CERA C	CK725F1A-105Z1	332181050R1
C1111	C-CERA C	CK725F1A-105Z1	332181050R1
C1112	C-CERA C	CK725F1A-105Z1	332181050R1
C1113	C-CERA C	CK725F1A-105Z1	332181050R1
C1115	C-CERA C	CK725F1A-105Z1	332181050R1
C1116	C-CERA C	CK725F1A-105Z1	332181050R1
C1117	C-CERA C	CK725F1A-105Z1	332181050R1
C1118	C-CERA C	CK725F1A-105Z1	332181050R1
C1119	C-CERA C	CK725F1A-105Z1	332181050R1
C1120	C-CERA C	CK725F1A-105Z1	332181050R1
C1121	C-CERA C	CK725F1A-105Z1	332181050R1
C1122	C-CERA C	CK725F1A-105Z1	332181050R1
C1123	C-CERA C	CK725F1A-105Z1	332181050R1
C1124	C-CERA C	CK725F1A-105Z1	332181050R1
C1125	C-CERA C	CC725CH1H-102J1	342101024R1
C1126	C-CERA C	CK725F1A-105Z1	332181050R1
C1128	C-CERA C	CK725F1A-105Z1	332181050R1
C1129	C-CERA C	CC725CH1H-101J1	342101014R1
C1136	C-CERA C	CK725F1A-105Z1	332181050R1
C1137	C-CERA C	CK725F1A-105Z1	332181050R1
C1138	C-CERA C	CK725F1A-105Z1	332181050R1
C1139	C-CERA C	CK725F1A-105Z1	332181050R1
C1140	C-CERA C	CK725F1A-105Z1	332181050R1
C1141	C-CERA C	CK725F1A-105Z1	332181050R1
C1142	C-CERA C	CK725F1A-105Z1	332181050R1
C1143	C-CERA C	CK725F1A-105Z1	332181050R1
C1144	C-CERA C	CK725F1A-105Z1	332181050R1
C1145	C-CERA C	CK725F1A-105Z1	332181050R1
C1146	C-CERA C	CK725F1A-105Z1	332181050R1
C1147	C-CERA C	CK725F1A-105Z1	332181050R1
C1148	CHIP ELECT C	CEWX4V-220M	3981G2217R2
C1149	C-CERA C	CK725F1A-105Z1	332181050R1
C1150	CHIP ELECT C	CEWX4V-220M	3981G2217R2

C1151	C-CERA C	CK725F1A-105Z1	332181050R1	
C1152	CHIP ELECT C	CEWX4V-220M	3981G2217R2	
C1153	C-CERA C	CK725F1A-105Z1	332181050R1	
C1154	CHIP ELECT C	CEWX4V-220M	3981G2217R2	
C1155	C-CERA C	CK725F1A-105Z1	332181050R1	
C1156	CHIP ELECT C	CEWX4V-220M	3981G2217R2	
C1161	C-CERA C	CK725F1A-105Z1	332181050R1	
C1162	CHIP ELECT C	CEWX6.3V-330M	398123317R2	
C1165	C-CERA C	CK725F1A-105Z1	332181050R1	
C1201	C-CERA C	CK725F1E-104Z1	332161040R1	
C1202	C-CERA C	CC725CH1H-101J1	342101014R1	
C1203	C-CERA C	CK725B1H-103K1	332101035R1	
C1204	C-CERA C	CK725B1H-103K1	332101035R1	
C1205	C-CERA C	CK725B1H-103K1	332101035R1	
C1206	C-CERA C	CC725CH1H-102J1	342101024R1	
C1207	C-CERA C	CK725F1E-104Z1	332161040R1	
C1208	CHIP ELECT C	CEWX16V-100M	398141017R2	
C1210	CHIP ELECT C	CEWX16V-100M	398141017R2	
C1211	C-CERA C	CK725F1A-105Z1	332181050R1	
C1212	C-CERA C	CK725F1A-105Z1	332181050R1	
C1213	C-CERA C	CK725F1A-105Z1	332181050R1	
C1214	C-CERA C	CK725B1C-104K1	332121045R1	
C1215	C-CERA C	CC725CH1H-101J1	342101014R1	
C1219	CHIP ELECT C	CEWX4V-220M	3981G2217R2	
C1220	CHIP ELECT C	CEWX4V-47M	3981G4707R2	
C1221	CHIP ELECT C	CEWX4V-47M	3981G4707R2	
C1222	C-CERA C	CK725F1A-105Z1	332181050R1	
C1223	C-CERA C	CK725F1A-105Z1	332181050R1	
C1224	C-CERA C	CK725B1H-103K1	332101035R1	
C1225	C-CERA C	CC725CH1H-102J1	342101024R1	
C1227	C-CERA C	CK725B1H-223K1	332102235R1	
C1228	C-CERA C	CK725B1H-223K1	332102235R1	
C1229	C-CERA C	CC725CH1H-102J1	342101024R1	
C1230	C-CERA C	CK725F1E-104Z1	332161040R1	
C1231	C-CERA C	CK725B1C-104K1	332121045R1	SPINDLE DETECT

C1232	CHIP ELECT C	CEWX10V-220M	398132217R2	SPINDLE DETECT
C1233	C-CERA C	CK725F1A-105Z1	332181050R1	SPINDLE DETECT
C1401	CHIP ELECT C	CEWX10V-220M	398132217R2	
C1402	C-CERA C	CK725F1E-104Z1	332161040R1	
C1405	C-CERA C	CK725F1E-104Z1	332161040R1	
C1406	CHIP ELECT C	CEWX16V-22M	398142207R2	
C1407	C-CERA C	CC725CH1H-220J1	342102204R1	
C1408	C-CERA C	CK725F1E-104Z1	332161040R1	
C1410	C-CERA C	CK725F1E-104Z1	332161040R1	
C1411	CHIP ELECT C	CEWX16V-22M	398142207R2	
C1412	CHIP ELECT C	CEWX10V-220M	398132217R2	
C1501	CHIP ELECT C	CEWX16V-100M	398141017R2	
C1502	C-CERA C	CK725F1A-105Z1	332181050R1	
C1503	CHIP ELECT C	CEWX16V-22M	398142207R2	
C1504	C-CERA C	CK725F1A-105Z1	332181050R1	
C1505	CHIP ELECT C	CEWX16V-100M	398141017R2	
C1506	C-CERA C	CK725F1A-105Z1	332181050R1	
C1507	CHIP ELECT C	CEWX16V-100M	398141017R2	
C1508	C-CERA C	CK725F1A-105Z1	332181050R1	
C1509	CHIP ELECT C	CEWX16V-100M	398141017R2	
C1510	C-CERA C	CK725F1A-105Z1	332181050R1	
C1511	CHIP ELECT C	CEWX16V-100M	398141017R2	
C1512	C-CERA C	CK725F1A-105Z1	332181050R1	
C1513	C-CERA C	CK725F1A-105Z1	332181050R1	
C1514	C-CERA C	CK725F1A-105Z1	332181050R1	
C1516	C-CERA C	CK725F1A-105Z1	332181050R1	
C1517	C-CERA C	CK725F1A-105Z1	332181050R1	
C1518	C-CERA C	CK725F1A-105Z1	332181050R1	
C1519	C-CERA C	CK725F1A-105Z1	332181050R1	
C1520	C-CERA C	CK725F1A-105Z1	332181050R1	
C1521	C-CERA C	CK725F1A-105Z1	332181050R1	
C1522	C-CERA C	CK725F1A-105Z1	332181050R1	
C1523	C-CERA C	CK725F1A-105Z1	332181050R1	
C1524	C-CERA C	CK725F1A-105Z1	332181050R1	
C1525	CHIP ELECT C	CEWX16V-100M	398141017R2	

C1559	C-CERA C	CK725F1A-105Z1	332181050R1
C1560	C-CERA C	CK725F1A-105Z1	332181050R1
C1561	C-CERA C	CK725F1A-105Z1	332181050R1
C1563	CHIP ELECT C	CEWX6.3V-22M	398122207R2
C1564	C-CERA C	CK725F1A-105Z1	332181050R1
C1565	CHIP ELECT C	CEWX4V-100M	3981G1017R2
C1566	C-CERA C	CK725F1A-105Z1	332181050R1
C1581	C-CERA C	CK725F1A-105Z1	332181050R1
C1582	CHIP ELECT C	CEWX4V-220M	3981G2217R2
C1583	C-CERA C	CK725F1A-105Z1	332181050R1
C1587	C-CERA C	CC725CH1H-100D1	342101002R1
C1589	C-CERA C	CC725CH1H-120J1	342101204R1
C1701	C-CERA C	CK725F1E-104Z1	332161040R1
C1702	C-CERA C	CK725F1E-104Z1	332161040R1
C1703	C-CERA C	CK725F1E-104Z1	332161040R1
C1704	C-CERA C	CK725F1E-104Z1	332161040R1
C1705	C-CERA C	CC725CH1H-102J1	342101024R1
C1706	C-CERA C	CC725CH1H-102J1	342101024R1
C1707	C-CERA C	CK725F1E-104Z1	332161040R1
C1712	CHIP ELECT C	CEWX16V-22M	398142207R2
C1713	CHIP ELECT C	CEWX16V-22M	398142207R2
C1714	C-CERA C	CK725F1E-104Z1	332161040R1
C1715	C-CERA C	CK725F1E-104Z1	332161040R1
C1716	CHIP ELECT C	CEWX4V-100M	3981G1017R2
C1717	C-CERA C	CK725F1A-105Z1	332181050R1
C1718	C-CERA C	CK725F1E-104Z1	332161040R1
C1719	C-CERA C	CC725CH1H-101J1	342101014R1
C1720	C-CERA C	CC725CH1H-101J1	342101014R1
C1722	CHIP ELECT C	CEWX16V-22M	398142207R2
C1723	C-CERA C	CC725CH1H-102J1	342101024R1
C1724	C-CERA C	CC725CH1H-102J1	342101024R1
C1725	C-CERA C	CC725CH1H-102J1	342101024R1
C1781	C-CERA C	CK725F1A-105Z1	332181050R1
C1851	C-CERA C	CK725F1A-105Z1	332181050R1
C1852	CHIP ELECT C	CEWX4V-220M	3981G2217R2

C1853	C-CERA C	CK725F1A-105Z1	332181050R1	
C1854	C-CERA C	CK725F1A-105Z1	332181050R1	
C1855	CHIP ELECT C	CEWX4V-220M	3981G2217R2	
C1856	C-CERA C	CK725F1A-105Z1	332181050R1	
C1857	C-CERA C	CK725F1A-105Z1	332181050R1	
C1858	C-CERA C	CK725F1A-105Z1	332181050R1	
C1859	C-CERA C	CK725F1A-105Z1	332181050R1	
C1860	C-CERA C	CK725F1A-105Z1	332181050R1	
C1861	C-CERA C	CK725F1A-105Z1	332181050R1	
C1862	C-CERA C	CK725F1A-105Z1	332181050R1	
C1863	C-CERA C	CC725CH1H-102J1	342101024R1	
C1901	CHIP ELECT C	CEWX16V-100M	398141017R2	
C1902	PW C	CE04W6.3V-470M(PW)	393724717	
C1903	CD C	UCD1A471MNL1GS	396634717R2	
C1904	C-CERA C	CK725F1A-105Z1	332181050R1	
C1905	C-CERA C	CK725F1A-105Z1	332181050R1	
C1907	CHIP ELECT C	CEWX4V-220M	3981G2217R2	
C1910	C-CERA C	CK725F1A-105Z1	332181050R1	
C1911	CHIP ELECT C	CEWX16V-100M	398141017R2	
C1912	C-CERA C	CK725F1A-105Z1	332181050R1	For Changer
C1913	CHIP ELECT C	CEWX10V-220M	398132217R2	
C1914	PW C	CE04W6.3V-470M(PW)	393724717	
C1915	C-CERA C	CK725F1A-105Z1	332181050R1	
C1916	CHIP ELECT C	CEWX4V-100M	3981G1017R2	
C1918	C-CERA C	CK725F1A-105Z1	332181050R1	For Changer
C1919	CHIP ELECT C	CEWX16V-100M	398141017R2	
C2001	C-CERA C	CK725B1H-103K1	332101035R1	
C2002	CHIP ELECT C	CEWX50V-1M	398180107R2	
C2003	CHIP ELECT C	CEWX50V-1M	398180107R2	
C2004	CHIP ELECT C	CEWX50V-1M	398180107R2	
C2005	CHIP ELECT C	CEWX50V-1M	398180107R2	
C2006	CHIP ELECT C	CEWX50V-1M	398180107R2	
C2007	C-CERA C	CK725F1A-105Z1	332181050R1	
C2008	CHIP ELECT C	CEWX6.3V-22M	398122207R2	
C2009	C-CERA C	CK725F1A-105Z1	332181050R1	

C2010	CHIP ELECT C	CEWX16V-100M	398141017R2	
C2011	CHIP ELECT C	CEWX6.3V-22M	398122207R2	
C2012	CHIP ELECT C	CEWX16V-100M	398141017R2	
C2013	CHIP ELECT C	CEWX6.3V-22M	398122207R2	
C2014	CHIP ELECT C	CEWX16V-100M	398141017R2	
C2015	CHIP ELECT C	CEWX6.3V-22M	398122207R2	
C2016	CHIP ELECT C	CEWX16V-100M	398141017R2	
C2017	CHIP ELECT C	CEWX6.3V-22M	398122207R2	
C2018	CHIP ELECT C	CEWX16V-100M	398141017R2	
C2019	CHIP ELECT C	CEWX6.3V-22M	398122207R2	
C2020	C-CERA C	CK725B1H-103K1	332101035R1	
C2021	C-CERA C	CK725B1H-103K1	332101035R1	
C2022	C-CERA C	CK725F1A-105Z1	332181050R1	
C2023	CHIP ELECT C	CEWX10V-220M	398132217R2	
C2028	C-CERA C	CK725F1A-105Z1	332181050R1	
D1551	C-DIODE	1SS226(TE85L_F)	223266R2	
D1701	C-DIODE	1SS352	223234R2	
D1701 or	C-DIODE	1SS355	223269R2	
D1701 or	C-DIODE	MA2J1110GL	223302R2	
D1703	C-DIODE	1SS352	223234R2	
D1703 or	C-DIODE	1SS355	223269R2	
D1703 or	C-DIODE	MA2J1110GL	223302R2	
D1905	LED	SEC1401C	225383R2	For power supply
D1906	C-DIODE	1SS352	223234R2	
D1906 or	C-DIODE	1SS355	223269R2	
D1906 or	C-DIODE	MA2J1110GL	223302R2	
D1907	DIODE	RB070M-30	22380361R2	
D1908	C-DIODE	1SS352	223234R2	
D1908 or	C-DIODE	1SS355	223269R2	
D1908 or	C-DIODE	MA2J1110GL	223302R2	
D1909	C-DIODE	1SS352	223234R2	
D1909 or	C-DIODE	1SS355	223269R2	
D1909 or	C-DIODE	MA2J1110GL	223302R2	
F1501	RESISTOR	nanoSMD C016F	4000239R2	
L1001	CHOKE COIL	LBC2518T220M	231364M220R2	

L1002	CHOKE COIL	LBC2518T220M	231364M220R2	
L1003	CHOKE COIL	LBC2518T220M	231364M220R2	
L1004	CHOKE COIL	LBC2518T220M	231364M220R2	
L1005	CHOKE COIL	BLM21PG221SN1	230949R2	
L1006	CHOKE COIL	BLM21PG221SN1	230949R2	
L1101	CHOKE COIL	BLM21PG221SN1	230949R2	
L1102	CHOKE COIL	BLM21PG221SN1	230949R2	
L1103	CHOKE COIL	BLM21PG221SN1	230949R2	
L1104	CHOKE COIL	BLM21PG221SN1	230949R2	
L1105	CHOKE COIL	BLM21PG221SN1	230949R2	
L1108	CHOKE COIL	BLM21PG221SN1	230949R2	
L1109	EMIFIL	BK1608LL241-T	230959R1	
L1110	EMIFIL	BK1608LL241-T	230959R1	
L1111	EMIFIL	BK1608LL680-T	2350013R1	N
L1112	C-CARBON R	RN72K1J-000JE	435030004R1	
L1113	CHOKE COIL	BLM21PG221SN1	230949R2	
L1201	CHOKE COIL	LBC2518T2R2M	231364M022R2	
L1401	CHOKE COIL	LBC2518T2R2M	231364M022R2	
L1402	CHOKE COIL	LBC2518T2R2M	231364M022R2	
L1403	CHOKE COIL	BLM21B222SPT	230921R2	
L1501	CHOKE COIL	BLM21PG221SN1	230949R2	
L1502	CHOKE COIL	BLM21PG221SN1	230949R2	
L1503	CHOKE COIL	BLM21PG221SN1	230949R2	
L1504	CHOKE COIL	BLM21PG221SN1	230949R2	
L1505	CHOKE COIL	BLM21PG221SN1	230949R2	
L1506	CHOKE COIL	BLM21PG221SN1	230949R2	
L1507	CHOKE COIL	BLM21PG221SN1	230949R2	
L1551	CHOKE COIL	BLM21PG221SN1	230949R2	
L1581	CHOKE COIL	BLM21PG221SN1	230949R2	
L1582	EMIFIL	BK1608LL241-T	230959R1	
L1583	EMIFIL	BK1608LL241-T	230959R1	
L1851	CHOKE COIL	BLM21PG221SN1	230949R2	
L1852	CHOKE COIL	BLM21PG221SN1	230949R2	
L1903	CHOKE COIL	NCH-2541	231363K470A	
L1903 or	COIL	0182-7310-470K-RB	231389	

L1904	CHOKE COIL	BLM21PG221SN1	230949R2	
L2001	CHOKE COIL	BLM21PG221SN1	230949R2	
P1002	FFC SOCKET	FH12-24S-0.5SH(55)	25053125R2	
P1203	SOCKET	NSCT-15P2478	25052581R2	
P1401C	SOCKET	15FMN-SMT-A-TF	25052832R2	To Audio 706
P1411	PIN JACK	NPJ-IPDOR403	25045592	COAX/Gold
P1551	SOCKET	YKF45-7037V	25053253R3	
P1702C	SOCKET	09FMN-SMT-A-TF	25052826R2	For RS232 IR
P1703C	SOCKET	31FMN-SMT-A-TF	25052848R2	To Display Changer
P1781	SOCKET	09FMN-SMT-A-TF	25052826R2	
P1901C	PLUG	NPLG-13P938	25055985R2	power I/F Changer
P2001	PIN JACK	NPJ-10PDBY518	25045730	10P/Gold
P2002	PIN JACK	NPJ-3PDGLR460	25045661	Component/Gold
P2004A	SOCKET	NSCT-9P2472	25052575R2	For D4 & Integra
Q1001	TR	HN1A01F-GR	2215915R2	
Q1002	TR	HN1A01F-GR	2215915R2	
Q1003	TR	2SC2712-GR	2213145R2	
Q1004	TR	2SC2712-GR	2213145R2	
Q1007	TR	2SC2712-GR	2213145R2	
Q1101	IC	ZR36886HLCG	22242536R3	CANNOT SACD
Q1101 or	IC	ZR36886HLCG-A	22242536AR3	
Q1103	IC	S-80127CNMC-JKM-T2	22241642R2	
Q1104	IC	TC74VHC157FT	22274157ER2TO	DSD SW
Q1201	IC	BD7967EFS	22242328R2	
Q1202	IC	NJM3404V	22241677R2	
Q1205	IC	BA4510FV	22241907R2	
Q1206	IC	TC74AC00FT	22242244R2	SPINDLE DETECT
Q1401	IC	TC74VHCU04FT	22274004HR2TO	
Q1501	IC	ZR36722PQCG	22242538R3	N
Q1502	IC	SN74CB3Q3305PWR	22242258R2	
Q1503	IC	TC7SZ125FU(TE85L_F)	22241895R2	
Q1504	IC	XC6213B332MR	22242277R2	
Q1505	TR ARRAY	UM6K1N	226066R2	
Q1581	IC	TC7WZU04FU(TE12L_F)	22242078R2TO	
Q1582	IC	TC7SHU04FU	22241638R2	

Q1701	IC	M3062LFGPPF U5	222W0048R3	
Q1702	TR	RN1402	2214470R2	
Q1702 or	TR	KRC102S	2216190R2	
Q1703	TR	DTC114EKA	2216250R2	
Q1704	TR	DTA114YKA	2216480R2	
Q1705	TR	DTA114YKA	2216480R2	
Q1706	TR	DTC114EKA	2216250R2	
Q1708	IC	S-24CS16A0I-J8V1G	22242326R2	
Q1710	IC	XC6213B332MR	22242277R2	
Q1711	TR	RN1402	2214470R2	
Q1711 or	TR	KRC102S	2216190R2	
Q1781	IC	TC7MBL3245SFT	22242539R2TO	N
Q1782	TR	2SK3019	2216520R2	
Q1783	TR	2SK3019	2216520R2	
Q1851	IC	M29W160ET-70N6E	222W0049R3	FOR CHANGER+single
Q1852	IC	K4S281632K-UC60	22242489R3	
Q1853	TR	2SK3019	2216520R2	
Q1901	IC	TA48018AF(TE16L_NQ)	22278018DR2TO	
Q1903	IC	XC6202P502FR	22242331R2	
Q1904	IC	SI8008TM	22242323R2	
Q1905	IC	TA48018AF(TE16L_NQ)	22278018DR2TO	
Q1906	IC	XC6202P502FR	22242331R2	
Q2001	IC	BH7868FS	22242329R2	
R1001	C-CARBON R	RN72K1J-047JE	435030474R1	
R1003	C-CARBON R	RN72K1J-047JE	435030474R1	
R1005	C-CARBON R	RN72K1J-221JE	435032214R1	
R1006	C-CARBON R	RN72K1J-332JE	435033324R1	
R1007	C-CARBON R	RN72K1J-047JE	435030474R1	
R1009	C-CARBON R	RN72K1J-047JE	435030474R1	
R1011	C-CARBON R	RN72K1J-221JE	435032214R1	
R1012	C-CARBON R	RN72K1J-332JE	435033324R1	
R1013	C-CARBON R	RN72K1J-000JE	435030004R1	
R1014	C-CARBON R	RN72K1J-000JE	435030004R1	
R1015	C-CARBON R	RN72K1J-471JE	435034714R1	
R1016	C-CARBON R	RN72K1J-000JE	435030004R1	

R1017	C-CARBON R	RN72K1J-000JE	435030004R1
R1018	C-CARBON R	RN72K1J-000JE	435030004R1
R1019	C-CARBON R	RN72K1J-000JE	435030004R1
R1020	C-CARBON R	RN72K1J-000JE	435030004R1
R1021	C-CARBON R	RN72K1J-000JE	435030004R1
R1022	C-CARBON R	RN72K1J-104FE	435031042R1
R1023	C-CARBON R	RN72K1J-103FE	435031032R1
R1024	C-CARBON R	RN72K1J-000JE	435030004R1
R1025	C-CARBON R	RN72K1J-470JE	435034704R1
R1026	C-CARBON R	RN72K1J-332JE	435033324R1
R1027	C-CARBON R	RN72K1J-000JE	435030004R1
R1028	C-CARBON R	RN72K1J-000JE	435030004R1
R1029	C-CARBON R	RN72K1J-000JE	435030004R1
R1030	C-CARBON R	RN72K1J-470JE	435034704R1
R1031	C-CARBON R	RN72K1J-000JE	435030004R1
R1032	C-CARBON R	RN72K1J-000JE	435030004R1
R1033	C-CARBON R	RN72K1J-103FE	435031032R1
R1101	C-CARBON R	RN72K1J-470JE	435034704R1
R1102	C-CARBON R	RN72K1J-472JE	435034724R1
R1103	C-CARBON R	RN72K1J-000JE	435030004R1
R1104	C-CARBON R	RN72K1J-000JE	435030004R1
R1105	C-CARBON R	RN72K1J-470JE	435034704R1
R1107	C-CARBON R	RN72K1J-470JE	435034704R1
R1108	C-CARBON R	RN72K1J-470JE	435034704R1
R1109	C-CARBON R	RN72K1J-472JE	435034724R1
R1110	C-CARBON R	RN72K1J-470JE	435034704R1
R1111	C-CARBON R	RN72K1J-470JE	435034704R1
R1112	C-CARBON R	RN72K1J-470JE	435034704R1
R1113	C-CARBON R	RN72K1J-470JE	435034704R1
R1114	C-CARBON R	RN72K1J-470JE	435034704R1
R1115	C-CARBON R	RN72K1J-470JE	435034704R1
R1116	C-CARBON R	RN72K1J-470JE	435034704R1
R1117	C-CARBON R	RN72K1J-470JE	435034704R1
R1118	C-CARBON R	RN72K1J-470JE	435034704R1
R1119	C-CARBON R	RN72K1J-470JE	435034704R1

R1122	C-CARBON R	RN72K1J-221JE	435032214R1	
R1127	C-CARBON R	RN72K1J-101JE	435031014R1	
R1131	C-CARBON R	RN72K1J-470JE	435034704R1	
R1132	C-CARBON R	RN72K1J-101JE	435031014R1	
R1133	C-CARBON R	RN72K1J-101JE	435031014R1	
R1137	C-CARBON R	RN72K1J-563JE	435035634R1	
R1138	C-CARBON R	RN72K1J-101JE	435031014R1	
R1140	C-CARBON R	RN72K1J-470JE	435034704R1	
R1141	C-CARBON R	RN72K1J-101JE	435031014R1	
R1142	C-CARBON R	RN72K1J-470JE	435034704R1	
R1143	C-CARBON R	RN72K1J-470JE	435034704R1	
R1144	C-CARBON R	RN72K1J-101JE	435031014R1	
R1145	C-CARBON R	RN72K1J-101JE	435031014R1	
R1146	C-CARBON R	RN72K1J-470JE	435034704R1	
R1147	C-CARBON R	RN72K1J-470JE	435034704R1	
R1153	C-CARBON R	RN72K1J-221JE	435032214R1	
R1154	C-CARBON R	RN72K1J-101JE	435031014R1	
R1155	C-CARBON R	RN72K1J-101JE	435031014R1	
R1156	C-CARBON R	RN72K1J-101JE	435031014R1	
R1159	C-CARBON R	RN72K1J-102JE	435031024R1	
R1161	C-CARBON R	RN72K1J-220JE	435032204R1	
R1165	C-CARBON R	RN72K1J-101JE	435031014R1	DAC CONTOROL DATA
R1166	C-CARBON R	RN72K1J-101JE	435031014R1	DAC CONTOROL CLK
R1168	C-CARBON R	RN72K1J-221FE	435032212R1	
R1169	C-CARBON R	RN72K1J-151FE	435031512R1	
R1170	C-CARBON R	RN72K1J-220FE	435032202R1	
R1171	C-CARBON R	RN72K1J-750FE	435037502R1	
R1172	C-CARBON R	RN72K1J-750FE	435037502R1	
R1173	C-CARBON R	RN72K1J-750FE	435037502R1	
R1174	C-CARBON R	RN72K1J-750FE	435037502R1	
R1175	C-CARBON R	RN72K1J-750FE	435037502R1	
R1176	C-CARBON R	RN72K1J-750FE	435037502R1	
R1177	C-CARBON R	RN72K1J-750FE	435037502R1	
R1178	C-CARBON R	RN72K1J-750FE	435037502R1	
R1179	C-CARBON R	RN72K1J-750FE	435037502R1	

R1180	C-CARBON R	RN72K1J-750FE	435037502R1
R1181	C-CARBON R	RN72K1J-750FE	435037502R1
R1182	C-CARBON R	RN72K1J-750FE	435037502R1
R1183	C-CARBON R	RN72K1J-470JE	435034704R1
R1184	C-CARBON R	RN72K1J-470JE	435034704R1
R1185	C-CARBON R	RN72K1J-470JE	435034704R1
R1186	C-CARBON R	RN72K1J-470JE	435034704R1
R1187	C-CARBON R	RN72K1J-470JE	435034704R1
R1188	C-CARBON R	RN72K1J-470JE	435034704R1
R1189	C-CARBON R	RN72K1J-470JE	435034704R1
R1190	C-CARBON R	RN72K1J-470JE	435034704R1
R1191	C-CARBON R	RN72K1J-473JE	435034734R1
R1192	C-CARBON R	RN72K1J-473JE	435034734R1
R1193	C-CARBON R	RN72K1J-470JE	435034704R1
R1194	C-CARBON R	RN72K1J-470JE	435034704R1
R1195	C-CARBON R	RN72K1J-103JE	435031034R1
R1197	C-CARBON R	RN72K1J-000JE	435030004R1
R1198	C-R NET	RM7LJ470X04	43484747004R2
R1199	C-R NET	RM7LJ470X04	43484747004R2
R1201	C-CARBON R	RN72K1J-102JE	435031024R1
R1202	C-CARBON R	RN72K1J-473JE	435034734R1
R1203	C-CARBON R	RN72K1J-473JE	435034734R1
R1204	C-CARBON R	RN72K1J-047JE	435030474R1
R1205	C-CARBON R	RN72K1J-047JE	435030474R1
R1206	C-CARBON R	RN72K1J-103JE	435031034R1
R1207	C-CARBON R	RN72K1J-473JE	435034734R1
R1208	C-CARBON R	RN72K1J-010JE	435030104R1
R1209	C-CARBON R	RN72K1J-010JE	435030104R1
R1210	C-CARBON R	RN72K1J-010JE	435030104R1
R1211	C-CARBON R	RN72K1J-010JE	435030104R1
R1212	C-CARBON R	RN72K1J-472JE	435034724R1
R1213	C-CARBON R	RN72K1J-000JE	435030004R1
R1214	C-CARBON R	RN72K1J-000JE	435030004R1
R1215	C-CARBON R	RN72K1J-018JE	435030184R1
R1216	C-CARBON R	RN72K1J-018JE	435030184R1

R1217	C-CARBON R	RN72K1J-018JE	435030184R1
R1218	C-CARBON R	RN72K1J-018JE	435030184R1
R1219	C-CARBON R	RN72K1J-018JE	435030184R1
R1220	C-CARBON R	RN72K1J-018JE	435030184R1
R1221	C-CARBON R	RN72K1J-018JE	435030184R1
R1224	C-CARBON R	RN72K1J-273JE	435032734R1
R1226	C-CARBON R	RN72K1J-273JE	435032734R1
R1227	C-CARBON R	RN72K1J-154JE	435031544R1
R1228	C-CARBON R	RN72K1J-223JE	435032234R1
R1237	C-CARBON R	RN72K1J-103FE	435031032R1
R1238	C-CARBON R	RN72K1J-103FE	435031032R1
R1240	C-CARBON R	RN72K1J-100JE	435031004R1
R1241	C-CARBON R	RN72K1J-000JE	435030004R1
R1242	C-CARBON R	RN72K1J-103JE	435031034R1
R1245	C-CARBON R	RN72K1J-273JE	435032734R1
R1246	C-CARBON R	RN72K1J-103JE	435031034R1
R1247	C-CARBON R	RN72K1J-153JE	435031534R1
R1248	C-CARBON R	RN72K1J-183JE	435031834R1
R1249	C-CARBON R	RN72K1J-273JE	435032734R1
R1250	C-CARBON R	RN72K1J-101JE	435031014R1
R1251	C-CARBON R	RN72K1J-101JE	435031014R1
R1252	C-CARBON R	RN72K1J-101JE	435031014R1
R1253	C-CARBON R	RN72K1J-101JE	435031014R1
R1254	C-CARBON R	RN72K1J-101JE	435031014R1
R1255	C-CARBON R	RN72K1J-101JE	435031014R1
R1256	C-CARBON R	RN72K1J-101JE	435031014R1
R1257	C-CARBON R	RN72K1J-101JE	435031014R1
R1258	C-CARBON R	RN72K1J-330JE	435033304R1
R1270	C-R NET	RM7LJ470X04	43484747004R2
R1271	C-CARBON R	RN72K1J-470JE	435034704R1
R1272	C-CARBON R	RN72K1J-470JE	435034704R1
R1273	C-CARBON R	RN72K1J-220JE	435032204R1
R1274	C-CARBON R	RN72K1J-220JE	435032204R1
R1275	C-CARBON R	RN72K1J-220JE	435032204R1
R1276	C-CARBON R	RN72K1J-220JE	435032204R1

R1277	C-CARBON R	RN72K1J-220JE	435032204R1	
R1278	C-R NET	RM7LJ470X04	43484747004R2	
R1279	C-R NET	RM7LJ470X04	43484747004R2	
R1280	C-R NET	RM7LJ470X04	43484747004R2	
R1281	C-R NET	RM7LJ470X04	43484747004R2	
R1282	C-CARBON R	RN72K1J-473JE	435034734R1	SPINDLE DETECT
R1283	C-CARBON R	RN72K1J-222JE	435032224R1	SPINDLE DETECT
R1290	C-CARBON R	RN72K1J-000JE	435030004R1	
R1291	C-CARBON R	RN72K1J-000JE	435030004R1	
R1292	C-CARBON R	RN72K1J-000JE	435030004R1	DVD RESET
R1401	C-CARBON R	RN72K1J-101JE	435031014R1	
R1403	C-CARBON R	RN72K1J-474JE	435034744R1	
R1405	C-CARBON R	RN72K1J-331JE	435033314R1	
R1406	C-CARBON R	RN72K1J-121JE	435031214R1	
R1407	C-CARBON R	RN72K1J-182JE	435031824R1	
R1409	C-CARBON R	RN72K1J-122JE	435031224R1	
R1410	C-CARBON R	RN72K1J-221JE	435032214R1	
R1411	C-CARBON R	RN72K1J-000JE	435030004R1	
R1501	C-R NET	RM7LJ470X04	43484747004R2	
R1502	C-R NET	RM7LJ470X04	43484747004R2	
R1503	C-CARBON R	RN72K1J-470JE	435034704R1	
R1504	C-CARBON R	RN72K1J-470JE	435034704R1	
R1505	C-CARBON R	RN72K1J-472JE	435034724R1	
R1506	C-CARBON R	RN72K1J-472JE	435034724R1	
R1507	C-CARBON R	RN72K1J-330JE	435033304R1	
R1511	C-CARBON R	RN72K1J-470JE	435034704R1	
R1512	C-CARBON R	RN72K1J-470JE	435034704R1	
R1513	C-CARBON R	RN72K1J-470JE	435034704R1	
R1514	C-CARBON R	RN72K1J-470JE	435034704R1	
R1515	C-CARBON R	RN72K1J-000JE	435030004R1	
R1516	C-CARBON R	RN72K1J-470JE	435034704R1	
R1517	C-CARBON R	RN72K1J-100JE	435031004R1	
R1518	C-CARBON R	RN72K1J-472JE	435034724R1	
R1519	C-CARBON R	RN72K1J-470JE	435034704R1	
R1520	C-CARBON R	RN72K1J-470JE	435034704R1	

R1521	C-CARBON R	RN72K1J-470JE	435034704R1
R1522	C-CARBON R	RN72K1J-470JE	435034704R1
R1525	C-CARBON R	RN72K1J-470JE	435034704R1
R1527	C-CARBON R	RN72K1J-103JE	435031034R1
R1528	C-CARBON R	RN72K1J-000JE	435030004R1
R1529	C-CARBON R	RN72K1J-000JE	435030004R1
R1530	C-CARBON R	RN72K1J-472JE	435034724R1
R1531	C-CARBON R	RN72K1J-472JE	435034724R1
R1533	C-CARBON R	RN72K1J-221JE	435032214R1
R1534	C-CARBON R	RN72K1J-472JE	435034724R1
R1535	C-CARBON R	RN72K1J-221JE	435032214R1
R1536	C-CARBON R	RN72K1J-101FE	435031012R1
R1537	C-CARBON R	RN72K1J-750JE	435037504R1
R1538	C-CARBON R	RN72K1J-750JE	435037504R1
R1539	C-CARBON R	RN72K1J-750JE	435037504R1
R1540	C-CARBON R	RN72K1J-331JE	435033314R1
R1541	C-CARBON R	RN72K1J-472JE	435034724R1
R1542	C-CARBON R	RN72K1J-000JE	435030004R1
R1543	C-CARBON R	RN72K1J-473JE	435034734R1
R1546	C-CARBON R	RN72K1J-391JE	435033914R1
R1551	C-R NET	MNR12E0APJ000	43464900002R2
R1552	C-R NET	MNR12E0APJ000	43464900002R2
R1553	C-R NET	MNR12E0APJ000	43464900002R2
R1554	C-R NET	MNR12E0APJ000	43464900002R2
R1555	C-CARBON R	RN72K1J-000JE	435030004R1
R1557	C-CARBON R	RN72K1J-000JE	435030004R1
R1559	C-CARBON R	RN72K1J-182JE	435031824R1
R1560	C-CARBON R	RN72K1J-182JE	435031824R1
R1562	C-CARBON R	RN72K1J-000JE	435030004R1
R1564	C-CARBON R	RN72K1J-102JE	435031024R1
R1566	C-CARBON R	RN72K1J-473JE	435034734R1
R1568	C-CARBON R	RN72K1J-000JE	435030004R1
R1569	C-CARBON R	RN72K1J-000JE	435030004R1
R1581	C-CARBON R	RN72K1J-221JE	435032214R1
R1582	C-CARBON R	RN72K1J-221JE	435032214R1

R1585	C-CARBON R	RN72K1J-105FE	435031052R1
R1586	C-CARBON R	RN72K1J-821FE	435038212R1
R1587	C-CARBON R	RN72K1J-331FE	435033312R1
R1588	C-CARBON R	RN72K1J-000JE	435030004R1
R1589	C-CARBON R	RN72K1J-000JE	435030004R1
R1592	C-CARBON R	RN72K1J-103JE	435031034R1
R1701	C-CARBON R	RN72K1J-470JE	435034704R1
R1702	C-CARBON R	RN72K1J-470JE	435034704R1
R1703	C-CARBON R	RN72K1J-221JE	435032214R1
R1704	C-CARBON R	RN72K1J-473JE	435034734R1
R1705	C-CARBON R	RN72K1J-470JE	435034704R1
R1708	C-CARBON R	RN72K1J-221JE	435032214R1
R1709	C-CARBON R	RN72K1J-103JE	435031034R1
R1711	C-CARBON R	RN72K1J-470JE	435034704R1
R1712	C-CARBON R	RN72K1J-103JE	435031034R1
R1713	C-CARBON R	RN72K1J-224JE	435032244R1
R1714	C-CARBON R	RN72K1J-470JE	435034704R1
R1717	C-CARBON R	RN72K1J-000JE	435030004R1
R1720	C-CARBON R	RN72K1J-221JE	435032214R1
R1721	C-CARBON R	RN72K1J-221JE	435032214R1
R1722	C-CARBON R	RN72K1J-221JE	435032214R1
R1723	C-CARBON R	RN72K1J-221JE	435032214R1
R1724	C-CARBON R	RN72K1J-221JE	435032214R1
R1725	C-CARBON R	RN72K1J-472JE	435034724R1
R1726	C-CARBON R	RN72K1J-221JE	435032214R1
R1727	C-CARBON R	RN72K1J-472JE	435034724R1
R1728	C-CARBON R	RN72K1J-103JE	435031034R1
R1729	C-CARBON R	RN72K1J-470JE	435034704R1
R1731	C-CARBON R	RN72K1J-470JE	435034704R1
R1732	C-CARBON R	RN72K1J-103JE	435031034R1
R1733	C-CARBON R	RN72K1J-470JE	435034704R1
R1734	C-CARBON R	RN72K1J-470JE	435034704R1
R1735	C-CARBON R	RN72K1J-470JE	435034704R1
R1736	C-CARBON R	RN72K1J-470JE	435034704R1
R1737	C-CARBON R	RN72K1J-470JE	435034704R1

R1739	C-CARBON R	RN72K1J-221JE	435032214R1	
R1740	C-CARBON R	RN72K1J-103JE	435031034R1	
R1741	C-CARBON R	RN72K1J-221JE	435032214R1	
R1742	C-CARBON R	RN72K1J-103JE	435031034R1	
R1743	C-CARBON R	RN72K1J-221JE	435032214R1	
R1744	C-CARBON R	RN72K1J-221JE	435032214R1	
R1745	C-CARBON R	RN72K1J-103JE	435031034R1	
R1746	C-CARBON R	RN72K1J-000JE	435030004R1	LD_CURRENT
R1748	C-CARBON R	RN72K1J-000JE	435030004R1	POS_SENS
R1750	C-CARBON R	RN72K1J-000JE	435030004R1	DISC_SENS
R1752	C-CARBON R	RN72K1J-470JE	435034704R1	
R1753	C-CARBON R	RN72K1J-221JE	435032214R1	
R1755	C-CARBON R	RN72K1J-470JE	435034704R1	
R1756	C-CARBON R	RN72K1J-470JE	435034704R1	
R1757	C-CARBON R	RN72K1J-221JE	435032214R1	
R1758	C-CARBON R	RN72K1J-221JE	435032214R1	
R1759	C-CARBON R	RN72K1J-221JE	435032214R1	
R1760	C-CARBON R	RN72K1J-221JE	435032214R1	
R1761	C-CARBON R	RN72K1J-221JE	435032214R1	
R1762	C-CARBON R	RN72K1J-221JE	435032214R1	
R1763	C-CARBON R	RN72K1J-221JE	435032214R1	
R1764	C-CARBON R	RN72K1J-221JE	435032214R1	
R1766	C-CARBON R	RN72K1J-470JE	435034704R1	
R1768	C-CARBON R	RN72K1J-221JE	435032214R1	
R1769	C-CARBON R	RN72K1J-103JE	435031034R1	
R1770	C-CARBON R	RN72K1J-473JE	435034734R1	
R1771	C-CARBON R	RN72K1J-000JE	435030004R1	
R1772	C-CARBON R	RN72K1J-273JE	435032734R1	
R1777	C-CARBON R	RN72K1J-221JE	435032214R1	
R1778	C-CARBON R	RN72K1J-473JE	435034734R1	
R1779	C-CARBON R	RN72K1J-221JE	435032214R1	
R1780	C-CARBON R	RN72K1J-103JE	435031034R1	
R1781	C-CARBON R	RN72K1J-221JE	435032214R1	
R1782	C-CARBON R	RN72K1J-221JE	435032214R1	
R1783	C-CARBON R	RN72K1J-472JE	435034724R1	

R1784	C-CARBON R	RN72K1J-221JE	435032214R1	
R1785	C-CARBON R	RN72K1J-273JE	435032734R1	
R1786	C-CARBON R	RN72K1J-221JE	435032214R1	
R1787	C-CARBON R	RN72K1J-221JE	435032214R1	
R1788	C-CARBON R	RN72K1J-103JE	435031034R1	
R1789	C-CARBON R	RN72K1J-221JE	435032214R1	
R1798	C-CARBON R	RN72K1J-473JE	435034734R1	
R1799	C-CARBON R	RN72K1J-473JE	435034734R1	
R1800	C-CARBON R	RN72K1J-473JE	435034734R1	
R1801	C-CARBON R	RN72K1J-221JE	435032214R1	
R1803	C-CARBON R	RN72K1J-333JE	435033334R1	
R1804	C-CARBON R	RN72K1J-472JE	435034724R1	
R1805	C-CARBON R	RN72K1J-272JE	435032724R1	
R1806	C-CARBON R	RN72K1J-472JE	435034724R1	
R1807	C-CARBON R	RN72K1J-272JE	435032724R1	
R1808	C-CARBON R	RN72K1J-221JE	435032214R1	
R1809	C-CARBON R	RN72K1J-473JE	435034734R1	
R1810	C-CARBON R	RN72K1J-562JE	435035624R1	BAND
R1811	C-CARBON R	RN72K1J-332JE	435033324R1	BAND
R1813	C-CARBON R	RN72K1J-000JE	435030004R1	INT1
R1815	C-CARBON R	RN72K1J-000JE	435030004R1	INT2
R1817	C-CARBON R	RN72K1J-000JE	435030004R1	INT3
R1819	C-CARBON R	RN72K1J-000JE	435030004R1	INT4
R1820	C-CARBON R	RN72K1J-101JE	435031014R1	
R1821	C-CARBON R	RN72K1J-103JE	435031034R1	
R1822	C-CARBON R	RN72K1J-224JE	435032244R1	
R1823	C-CARBON R	RN72K1J-101JE	435031014R1	
R1824	C-CARBON R	RN72K1J-000JE	435030004R1	
R1828	C-CARBON R	RN72K1J-222JE	435032224R1	
R1829	C-CARBON R	RN72K1J-222JE	435032224R1	
R1830	C-CARBON R	RN72K1J-473JE	435034734R1	
R1831	C-CARBON R	RN72K1J-473JE	435034734R1	
R1832	C-CARBON R	RN72K1J-272JE	435032724R1	<MUA>
R1832	C-CARBON R	RN72K1J-332JE	435033324R1	<MUP>
R1833	C-CARBON R	RN72K1J-103JE	435031034R1	<MDD>

R1833	C-CARBON R	RN72K1J-562JE	435035624R1	<MUP> DVD_REG
R1834	C-CARBON R	RN72K1J-272JE	435032724R1	CHG_ADJ
R1835	C-CARBON R	RN72K1J-272JE	435032724R1	CHG_ADJ
R1836	C-CARBON R	RN72K1J-563JE	435035634R1	
R1837	C-CARBON R	RN72K1J-104JE	435031044R1	
R1838	C-CARBON R	RN72K1J-104JE	435031044R1	
R1840	C-CARBON R	RN72K1J-000JE	435030004R1	
R1843	C-CARBON R	RN72K1J-104JE	435031044R1	
R1844	C-CARBON R	RN72K1J-104JE	435031044R1	
R1851	C-CARBON R	RN72K1J-103JE	435031034R1	
R1852	C-CARBON R	RN72K1J-102JE	435031024R1	
R1853	C-CARBON R	RN72K1J-102JE	435031024R1	
R1854	C-CARBON R	RN72K1J-102JE	435031024R1	
R1855	C-CARBON R	RN72K1J-472JE	435034724R1	
R1856	C-CARBON R	RN72K1J-472JE	435034724R1	
R1857	C-CARBON R	RN72K1J-000JE	435030004R1	
R1858	C-CARBON R	RN72K1J-472JE	435034724R1	
R1859	C-R NET	RM7LJ470X04	43484747004R2	
R1860	C-R NET	RM7LJ470X04	43484747004R2	
R1861	C-R NET	RM7LJ470X04	43484747004R2	
R1862	C-R NET	RM7LJ470X04	43484747004R2	
R1863	C-R NET	RM7LJ470X04	43484747004R2	
R1864	C-R NET	RM7LJ470X04	43484747004R2	
R1865	C-R NET	RM7LJ470X04	43484747004R2	
R1866	C-R NET	RM7LJ470X04	43484747004R2	
R1867	C-R NET	RM7LJ470X04	43484747004R2	
R1868	C-R NET	RM7LJ470X04	43484747004R2	
R1869	C-R NET	RM7LJ470X04	43484747004R2	
R1870	C-R NET	RM7LJ470X04	43484747004R2	
R1871	C-R NET	RM7LJ470X04	43484747004R2	
R1909	C-CARBON R	RN72K1J-471JE	435034714R1	
R1910	C-CARBON R	RN72K1J-102JE	435031024R1	
R1911	C-CARBON R	RN72K1J-392JE	435033924R1	
R1912	C-CARBON R	RN72K1J-392JE	435033924R1	
R1913	C-CARBON R	RN72K1J-682JE	435036824R1	

R2004	C-CARBON R	RN72K1J-750JE	435037504R1	
R2005	C-CARBON R	RN72K1J-750JE	435037504R1	
R2006	C-CARBON R	RN72K1J-750JE	435037504R1	
R2007	C-CARBON R	RN72K1J-103JE	435031034R1	
R2008	C-CARBON R	RN72K1J-750JE	435037504R1	
R2009	C-CARBON R	RN72K1J-750JE	435037504R1	
R2010	C-CARBON R	RN72K1J-750JE	435037504R1	
R2011	C-CARBON R	RN72K1J-103JE	435031034R1	
R2012	C-CARBON R	RN72K1J-750JE	435037504R1	
R2013	C-CARBON R	RN72K1J-750JE	435037504R1	
R2014	C-CARBON R	RN72K1J-750JE	435037504R1	
R2015	C-CARBON R	RN72K1J-000JE	435030004R1	
R2016	C-CARBON R	RN72K1J-000JE	435030004R1	
R2017	C-CARBON R	RN72K1J-000JE	435030004R1	
R2040	C-CARBON R	RN72K1J-000JE	435030004R1	
R2041	C-CARBON R	RN72K1J-000JE	435030004R1	For Except Scart
R2045	C-CARBON R	RN72K1J-000JE	435030004R1	
R2046	C-CARBON R	RN72K1J-000JE	435030004R1	
R2047	C-CARBON R	RN72K1J-000JE	435030004R1	
R2048	C-CARBON R	RN72K1J-000JE	435030004R1	
R2049	C-CARBON R	RN72K1J-000JE	435030004R1	
R2050	C-CARBON R	RN72K1J-000JE	435030004R1	
R2051	C-CARBON R	RN72K1J-000JE	435030004R1	
U1402	PHT CP	GP1FAV31TK0F	24120157	N
X1581	CRYSTAL	TSX-3225-27MHz	3010465R2	N
X1701	CERA LOCK	CR06000-CG-K0R	3010462R2	N

PRITED CIRCUIT BOARD PARTS LIST

DPC-7.9

U02 :	Display circuit PC board NADIS-9648-1B	1H554548-1B	<MDD><MUA><MUP>
U03 :	Mecha. Control PC board NADG-9649-1B	1H554549-1B	<MDD><MUA><MUP>
U04 :	Audio output terminal PC board NAAF-9650-1B	1H554550-1B	<MDD><MUA><MUP>
U05 :	Standby switch PC board NASW-6952-1B	1H554552-1B	<MDD><MUA><MUP>
U07 :	Disc operation PC board NASW-9655-1B	1H554555-1B	<MDD><MUA><MUP>
U08 :	Illumination PC board NADIS-9656-1B	1H554556-1B	<MDD><MUA><MUP>

U09 :	Loading motor PC board NAETC-9657-1B	1H554557-1B	<MDD><MUA><MUP>
U10 :	Roulette motor PC board NAETC-9659-1B	1H554559-1B	<MDD><MUA><MUP>
U11:	AC Inlet terminal PC board NAETC-9661-1B	1H554561-1B	<MDD><MUA><MUP>
U12 :	DISC Sensor PC board NAETC-9662-1B	1H554562-1B	<MDD><MUA><MUP>
U13 :	RS-232C terminal PC board NAPS-9651-1B	1H554551-1B	<MDD><MUA><MUP>
U14 :	Connection PC board NAETC-9660-1B	1H554560-1B	<MDD><MUA><MUP>

CIRCUIT NO	PART NAME	DESCRIPTION	PART NO.	REMARKS
C4001	TF C	ECQ-B50V-331K	374723315T	
C4002	TF C	ECQ-B50V-331K	374723315T	
C4003	TF C	ECQ-B50V-221K	374722215T	
C4004	TF C	ECQ-B50V-221K	374722215T	
C4005	TF C	ECQ-B50V-221K	374722215T	
C4006	TF C	ECQ-B50V-221K	374722215T	
C4007	TF C	ECQ-B50V-122J	374721224T	
C4008	TF C	ECQ-B50V-122J	374721224T	
C4009	TF C	ECQ-B50V-272J	374722724T	
C4010	TF C	ECQ-B50V-272J	374722724T	
C4011	UTSP C	CE04W50V-47M(UTSP)	397584707T	
C4012	UTSP C	CE04W50V-47M(UTSP)	397584707T	
C4016	UTSP C	CE04W50V-10M(UTSP)	397581007T	
C4017	TF C	ECQ-V50V-104J	374721044T	
C4018	UTSP C	CE04W10V-470M(UTSP)	397534717T	
C4019	UTSP C	CE04W10V-470M(UTSP)	397534717T	
C4020	TF C	ECQ-V50V-104J	374721044T	
C4021	TF C	ECQ-V50V-104J	374721044T	
C4023	UTSP C	CE04W10V-470M(UTSP)	397534717T	
C4024	TF C	ECQ-V50V-104J	374721044T	
C4025	TF C	ECQ-V50V-104J	374721044T	
C4026	TF C	ECQ-V50V-104J	374721044T	
C4027	UTSP C	CE04W16V-470M(UTSP)	397544717T	
C4028	UTSP C	CE04W16V-470M(UTSP)	397544717T	
C4029	UTSP C	CE04W16V-470M(UTSP)	397544717T	
C4030	UTSP C	CE04W16V-470M(UTSP)	397544717T	
C4031	VR C	CE04W16V-1000M(VR)	394641027T	

C4032	C-CERA C	CC725CH1H-101J1	342101014R1
C4033	C-CERA C	CK725F1E-104Z1	332161040R1
C4034	C-CERA C	CK725F1E-104Z1	332161040R1
C4036	TF C	ECQ-B50V-102J	374721024T
C4037	TF C	ECQ-B50V-102J	374721024T
C4038	TF C	ECQ-B50V-102J	374721024T
C4039	TF C	ECQ-B50V-102J	374721024T
C4040	TF C	ECQ-V50V-104J	374721044T
C4046	C-CERA C	CK725F1A-105Z1	332181050R1
C4047	TF C	ECQ-B50V-102J	374721024T
C7005	C-CERA C	CK725B1H-223K1	332102235R1
C7006	C-CERA C	CK725F1E-104Z1	332161040R1
C7007	TF C	ECQ-B50V-223J	374722234T
C7008	VR C	CE04W16V-100M(VR)	394641017T
C7010	ELECT C	CE04W16V-47M	355744709T
C7011	C-CERA C	CK725B1H-223K1	332102235R1
C7012	C-CERA C	CK725F1E-104Z1	332161040R1
C7013	C-CERA C	CK725F1E-104Z1	332161040R1
C7014	C-CERA C	CK725F1A-105Z1	332181050R1
C7015	VR C	CE04W50V-0.47M(VR)	394684797T
C7016	VR C	CE04W50V-0.47M(VR)	394684797T
C7017	VR C	CE04W16V-100M(VR)	394641017T
C7018	VR C	CE04W50V-0.47M(VR)	394684797T
C7019	C-CERA C	CK725F1E-104Z1	332161040R1
C7020	VR C	CE04W50V-0.47M(VR)	394684797T
C7021	C-CERA C	CK725F1E-104Z1	332161040R1
C7022	ELECT C	CE04W16V-100M	355741019T
C7023	C-CERA C	CK725F1E-104Z1	332161040R1
C7024	ELECT C	CE04W16V-100M	355741019T
C7025	C-CERA C	CK725F1E-104Z1	332161040R1
C7026	C-CERA C	CK725F1E-104Z1	332161040R1
C7027	C-CERA C	CK725F1E-104Z1	332161040R1
C7028	TF C	ECQ-B50V-472J	374724724T
C8001	VR C	CE04W50V-10M(VR)	394681007T
C8002	C-CERA C	CK725F1E-104Z1	332161040R1

C8003	C-CERA C	CK725F1E-104Z1	332161040R1
C8004	C-CERA C	CK725F1E-104Z1	332161040R1
C8005	C-CERA C	CK725F1E-104Z1	332161040R1
C8006	C-CERA C	CC725CH1H-102J1	342101024R1
C8007	VR C	CE04W50V-10M(VR)	394681007T
C8008	C-CERA C	CC725CH1H-102J1	342101024R1
C8010	C-CERA C	CK725F1E-104Z1	332161040R1
C8012	C-CERA C	CK725F1E-104Z1	332161040R1
C8013	C-CERA C	CK725F1E-104Z1	332161040R1
C8014	C-CERA C	CK725F1E-104Z1	332161040R1
C8015	C-CERA C	CK725F1E-104Z1	332161040R1
C8018	C-CERA C	CK725F1E-104Z1	332161040R1
C8021	C-CERA C	CC725CH1H-102J1	342101024R1
C8023	C-CERA C	CK725F1E-104Z1	332161040R1
C8025	C-CERA C	CK725F1E-104Z1	332161040R1
C8026	C-CERA C	CK725F1E-104Z1	332161040R1
C8027	C-CERA C	CC725CH1H-330J1	342103304R1
C8029	C-CERA C	CK725F1E-104Z1	332161040R1
C8030	C-CERA C	CK725F1E-104Z1	332161040R1
C8031	VR C	CE04W16V-100M(VR)	394641017T
C8033	CERA C	CK45F50V-223Z	335622230T
C8034	CERA C	CK45F50V-223Z	335622230T
C8035	CERA C	CK45F50V-223Z	335622230T
C8036	CERA C	CK45F50V-223Z	335622230T
C8037	CERA C	CK45F50V-223Z	335622230T
C8038	C-CERA C	CK725F1H-104Z1	332151040R1
C8039	C-CERA C	CK725F1E-104Z1	332161040R1
C8042	C-CERA C	CK725F1H-104Z1	332151040R1
C8051	VR C	CE04W16V-100M(VR)	394641017T
C8052	VR C	CE04W16V-100M(VR)	394641017T
D4001	C-DIODE	1SS352	223234R2
D4001 or	C-DIODE	1SS355	223269R2
D4001 or	C-DIODE	KDS4148U	223283R2
D4001 or	C-DIODE	MA2J111	223279R2
D4001 or	C-DIODE	MA2J1110GL	223302R2

D7002	ZENER D	UDZS 2.7B	224550270R2	
D7003	ZENER D	UDZS4.3B	224550430R2	
D7004	C-DIODE	1SS352	223234R2	
D7004 or	C-DIODE	1SS355	223269R2	
D7004 or	C-DIODE	KDS4148U	223283R2	
D7004 or	C-DIODE	MA2J111	223279R2	
D7004 or	C-DIODE	MA2J1110GL	223302R2	
D7005	C-DIODE	1SS352	223234R2	
D7005 or	C-DIODE	1SS355	223269R2	
D7005 or	C-DIODE	KDS4148U	223283R2	
D7005 or	C-DIODE	MA2J111	223279R2	
D7005 or	C-DIODE	MA2J1110GL	223302R2	
D7091	C-DIODE	1SS352	223234R2	
D7091 or	C-DIODE	1SS355	223269R2	
D7091 or	C-DIODE	KDS4148U	223283R2	
D7091 or	C-DIODE	MA2J111	223279R2	
D7091 or	C-DIODE	MA2J1110GL	223302R2	
D8001	LED	SCB3318E-D	225481	N
D8001A	HOLDER	(LED)LA-5-6	27191190	
D8002	ZENER D	UDZS5.6B	224550560R2	
D8003	LED	SCB3318E-D	225481	N
D8003A	HOLDER	(LED)LA-5-6	27191190	
D8004	LED	SLI-343URC3F(S,T,U,V)	225483	N
D8005	C-DIODE	1SS352	223234R2	
D8005 or	C-DIODE	1SS355	223269R2	
D8005 or	C-DIODE	KDS4148U	223283R2	
D8005 or	C-DIODE	MA2J111	223279R2	
D8005 or	C-DIODE	MA2J1110GL	223302R2	
E4001	WS CLAMP	CB-71683(L=50)	260261	
L4001	EMIFIL	BK1608LM182-T	230958R1	
L7004	EMIFIL	BK1608LM182-T	230958R1	
L7006	EMIFIL	BK1608LM182-T	230958R1	
L901	CORE	TR-25-15-12(Dot)	230997	
P1351	BNC JACK	YKC31-0157	25045739	
P1401B	SOCKET	NSCT-15P2406	25052509	

P1702A	SOCKET	NSCT-9P2206	25052309	
P1703B	SOCKET	NSCT-31P2265	25052368	N
P1703B or	SOCKET	9615S-31C-PP	25053319	N
P2004B	SOCKET	NSCT-9P2206	25052309	
P4004	PIN JACK	NPJ-4PDRW469	25045671	
P4005	ST JACK	SM0505-0021	25045857	
P4901	PLUG	NPLG-3P131	25055147	
P7002A	SOCKET	NSCT-7P2100	25052203	
P7002B	SOCKET	NSCT-7P2137	25052240	
P7004	ST JACK	HSJ1002-01-6020	25045647	RI:
P7005	SOCKET AS	NSAS-4P0867	2002E390415	
P7005A	PLUG	NPLG-2P130	25055146	
P7007	SOCKET	7906-09FHA	25053103	
P7007 or	SOCKET	NSCT-9P2277	25052379	
P7009	SOCKET AS	NSAS-4P0754	2002A390420UL	
P7009A	PLUG	NPLG-2P349	25055366	PH-SIDE POST
P7018	SOCKET AS	NSAS-18P1766	2002E391815AUL	N
P7018A	PLUG	NPLG-9P137	25055153	
P7018C	PLUG	NPLG-9P137	25055153	
P7018D	SOCKET AS	NSAS-18P1769	2002E391845AUL	N
P7019	SOCKET AS	NSAS-14P0954	2002E391415UL	
P7019A	PLUG	NPLG-7P135	25055151	
P7019C	PLUG	NPLG-7P135	25055151	
P7019D	SOCKET AS	NSAS-14P1770	2002E391440UL	N
P8002B	SOCKET AS	NSAS-4P1767	200EE390415UL	
P8008	PLUG	NPLG-9P137	25055153	ph top
P8008B	SOCKET AS	NSAS-18P1768	2002E391805UL	
P8012	SOCKET AS	NSAS-8P1012	2009990721UL	
P8012A	PLUG	NPLG-4P132	25055148	
P8013	CRIMP AS	CRIMP AS	2067A12060UL	N
P901A	AC INLET	NPLG-2P913	25055960	
P905	SOCKET AS	NSAS-4P1779	2009991139UL	N L=230
Q4001	IC	NJM4580M-D	22241448R2	
Q4002	IC	NJM4580M-D	22241448R2	
Q4003	IC	NJM4580M-D	22241448R2	

Q4004	IC	NJM4580M-D	22241448R2
Q4005	TR	2SD655-E	2211705T
Q4005 or	TR	2SD655-F	2211706T
Q4006	TR	2SD655-E	2211705T
Q4006 or	TR	2SD655-F	2211706T
Q4007	TR	2SD655-E	2211705T
Q4007 or	TR	2SD655-F	2211706T
Q4008	TR	2SD655-E	2211705T
Q4008 or	TR	2SD655-F	2211706T
Q4009	IC	TC7SHU04FU	22241638R2
Q4010	IC	WM8718SEDS/RV	22241991R2
Q4011	IC	78M05(NJM78M05FA)	222780055JRC
Q4012	TR	KRA107S	2216350R2
Q4012 or	TR	RN2407(TE85L_F)	2216360R2
Q4014	TR	KRC107S	2216340R2
Q4014 or	TR	RN1407	2216260R2
Q4015	TR	KRC107S	2216340R2
Q4015 or	TR	RN1407	2216260R2
Q4016	TR	2SC2712-GR	2213145R2
Q4017	IC	S-812C33AUA-C2N	22242222R2
Q4018	TR	KRC107S	2216340R2
Q4018 or	TR	RN1407	2216260R2
Q4019	TR	KRC107S	2216340R2
Q4019 or	TR	RN1407	2216260R2
Q4020	TR	2SC2712-GR	2213145R2
Q7001	TR	KRC107S	2216340R2
Q7001 or	TR	RN1407	2216260R2
Q7002	TR	KRC107S	2216340R2
Q7002 or	TR	RN1407	2216260R2
Q7003	PHT INT	GP2S28	24190046
Q7004	PHT CP	PS2501AL-1	24120141R2
Q7005	TR	KRC107S	2216340R2
Q7005 or	TR	RN1407	2216260R2
Q7006	TR	KRC107S	2216340R2
Q7006 or	TR	RN1407	2216260R2

Q7007	TR	KRC107S	2216340R2	
Q7007 or	TR	RN1407	2216260R2	
Q7008	TR	KRC107S	2216340R2	
Q7008 or	TR	RN1407	2216260R2	
Q7009	PHT CP	RPI-576	24120107	
Q7010	IC	TA7291SG(5_J)	22240239	
Q7011	IC	ICL3221ECVZ	22242268R2	
Q7013	TR	KRC107S	2216340R2	
Q7013 or	TR	RN1407	2216260R2	
Q7014	IC	TA7291SG(5_J)	22240239	
Q7015	TR	2SA1162-GR	2214375R2	
Q7016	TR	KRA107S	2216350R2	
Q7016 or	TR	RN2407(TE85L_F)	2216360R2	
Q7017	TR	2SD655-E	2211705T	
Q7017 or	TR	2SD655-F	2211706T	
Q7018	TR	2SD655-E	2211705T	
Q7018 or	TR	2SD655-F	2211706T	
Q7019	IC	TC74VHCT08AFT (EKJ)	22274008G1R2TO	
Q8001	FL TUBE	HNV-12SM34	212236	
Q8001A	HOLDER	(FL)	27191195	
Q8001B	SCREW	3TTB+6B(3BC)	838430068GR	
Q8002	TR	2SC2712-GR	2213145R2	
Q8003	IC	MPD780232GC-710-8BT-A	22242286R3	
Q8004	TR	2SC2712-GR	2213145R2	
Q8005	TR	KRC107S	2216340R2	
Q8005 or	TR	RN1407	2216260R2	
Q8006	REMO SENS	GPIUX311QS	24130015	N
Q8007	TR	KRC107S	2216340R2	
Q8007 or	TR	RN1407	2216260R2	
Q8051	IC	MPC29M33AT-E1-A	22278033EAR2NE	
R4001	C-CARBON R	RN72K1J-122JE	435031224R1	
R4002	C-CARBON R	RN72K1J-122JE	435031224R1	
R4003	C-CARBON R	RN72K1J-122JE	435031224R1	
R4004	C-CARBON R	RN72K1J-122JE	435031224R1	
R4005	C-CARBON R	RN72K1J-102JE	435031024R1	

R4006	C-CARBON R	RN72K1J-102JE	435031024R1
R4007	C-CARBON R	RN72K1J-102JE	435031024R1
R4008	C-CARBON R	RN72K1J-102JE	435031024R1
R4009	C-CARBON R	RN72K1J-472JE	435034724R1
R4010	C-CARBON R	RN72K1J-472JE	435034724R1
R4011	C-CARBON R	RN72K1J-472JE	435034724R1
R4012	C-CARBON R	RN72K1J-472JE	435034724R1
R4013	C-CARBON R	RN72K1J-103JE	435031034R1
R4014	C-CARBON R	RN72K1J-103JE	435031034R1
R4015	C-CARBON R	RN72K1J-103JE	435031034R1
R4016	C-CARBON R	RN72K1J-103JE	435031034R1
R4017	C-CARBON R	RN72K1J-152JE	435031524R1
R4018	C-CARBON R	RN72K1J-152JE	435031524R1
R4019	C-CARBON R	RN72K1J-223JE	435032234R1
R4020	C-CARBON R	RN72K1J-223JE	435032234R1
R4021	C-CARBON R	RN72K1J-223JE	435032234R1
R4022	C-CARBON R	RN72K1J-223JE	435032234R1
R4023	C-CARBON R	RN72K1J-223JE	435032234R1
R4024	C-CARBON R	RN72K1J-223JE	435032234R1
R4025	C-CARBON R	RN72K1J-223JE	435032234R1
R4026	C-CARBON R	RN72K1J-223JE	435032234R1
R4027	C-CARBON R	RN72K1J-152JE	435031524R1
R4028	C-CARBON R	RN72K1J-152JE	435031524R1
R4029	C-CARBON R	RN72K1J-152JE	435031524R1
R4030	C-CARBON R	RN72K1J-152JE	435031524R1
R4033	C-CARBON R	RN72K1J-103JE	435031034R1
R4034	C-CARBON R	RN72K1J-103JE	435031034R1
R4035	C-CARBON R	RN72K1J-224JE	435032244R1
R4036	C-CARBON R	RN72K1J-224JE	435032244R1
R4037	C-CARBON R	RN72K1J-221JE	435032214R1
R4038	C-CARBON R	RN72K1J-221JE	435032214R1
R4039	C-CARBON R	RN72K1J-222JE	435032224R1
R4040	C-CARBON R	RN72K1J-222JE	435032224R1
R4041	C-CARBON R	RN72K1J-222JE	435032224R1
R4042	C-CARBON R	RN72K1J-222JE	435032224R1

R4043	C-CARBON R	RN72K1J-221JE	435032214R1
R4044	C-CARBON R	RN72K1J-221JE	435032214R1
R4045	C-CARBON R	RN72K1J-101JE	435031014R1
R4046	C-CARBON R	RN72K1J-101JE	435031014R1
R4048	C-CARBON R	RN72K1J-000JE	435030004R1
R4049	C-CARBON R	RN72K1J-471JE	435034714R1
R4050	C-CARBON R	RN72K1J-103JE	435031034R1
R4051	C-CARBON R	RN72K1J-330JE	435033304R1
R4052	METAL O R	RS1/2WBJ-150	443521514T
R4053	METAL O R	RS1/2WBJ-150	443521514T
R4054	C-CARBON R	RN72K1J-474JE	435034744R1
R4056	C-CARBON R	RN72K1J-472JE	435034724R1
R4057	C-CARBON R	RN72K1J-224JE	435032244R1
R4058	C-CARBON R	RN72K1J-000JE	435030004R1
R4061	C-CARBON R	RN72K1J-471JE	435034714R1
R4062	C-CARBON R	RN72K1J-000JE	435030004R1
R4085	C-CARBON R	RN72K1J-221JE	435032214R1
R4086	C-CARBON R	RN72K1J-221JE	435032214R1
R4087	C-CARBON R	RN72K1J-221JE	435032214R1
R4088	C-CARBON R	RN72K1J-221JE	435032214R1
R4089	C-CARBON R	RN72K1J-000JE	435030004R1
R4090	C-CARBON R	RN72K1J-332JE	435033324R1
R4091	C-CARBON R	RN72K1J-103JE	435031034R1
R4101	C-CARBON R	RN72K1J-470JE	435034704R1
R4102	C-CARBON R	RN72K1J-470JE	435034704R1
R4103	C-CARBON R	RN72K1J-470JE	435034704R1
R4104	C-CARBON R	RN72K1J-470JE	435034704R1
R4105	C-CARBON R	RN72K1J-470JE	435034704R1
R4106	C-CARBON R	RN72K1J-470JE	435034704R1
R4113	METAL O R	RS1/2WBJ-100	443521014T
R7002	C-CARBON R	RN72K1J-332JE	435033324R1
R7003	C-CARBON R	RN72K1J-103JE	435031034R1
R7004	C-CARBON R	RN72K1J-822JE	435038224R1
R7005	C-CARBON R	RN72K1J-223JE	435032234R1
R7006	C-CARBON R	RN72K1J-105JE	435031054R1

R7007	C-CARBON R	RN72K1J-181JE	435031814R1
R7008	C-CARBON R	RN72K1J-332JE	435033324R1
R7009	C-CARBON R	RN72K1J-000JE	435030004R1
R7010	C-CARBON R	RN72K1J-103JE	435031034R1
R7011	C-CARBON R	RN72K1J-103JE	435031034R1
R7012	C-CARBON R	RN72K1J-154JE	435031544R1
R7013	C-CARBON R	RN72K1J-101JE	435031014R1
R7014	C-CARBON R	RN72K1J-562JE	435035624R1
R7015	C-CARBON R	RN72K1J-103JE	435031034R1
R7016	C-CARBON R	RN72K1J-000JE	435030004R1
R7017	C-CARBON R	RN72K1J-391JE	435033914R1
R7018	C-CARBON R	RN72K1J-822JE	435038224R1
R7019	C-CARBON R	RN72K1J-153JE	435031534R1
R7020	C-CARBON R	RN72K1J-105JE	435031054R1
R7021	C-CARBON R	RN72K1J-474JE	435034744R1
R7022	C-CARBON R	RN72K1J-183JE	435031834R1
R7023	C-CARBON R	RN72K1J-183JE	435031834R1
R7024	C-CARBON R	RN72K1J-104JE	435031044R1
R7025	C-CARBON R	RN72K1J-104JE	435031044R1
R7028	NF CARBON R	R25J-4.7	415470474T
R7034	C-CARBON R	RN72K1J-222JE	435032224R1
R7039	C-CARBON R	RN72K1J-104JE	435031044R1
R7040	C-CARBON R	RN72K1J-104JE	435031044R1
R7041	NF CARBON R	R25J-4.7	415470474T
R7042	C-CARBON R	RN72K1J-562JE	435035624R1
R7043	C-CARBON R	RN72K1J-822JE	435038224R1
R7045	C-CARBON R	RN72K1J-222JE	435032224R1
R7047	C-CARBON R	RN72K1J-472JE	435034724R1
R7048	C-CARBON R	RN72K1J-000JE	435030004R1
R7050	C-CARBON R	RN72K1J-392JE	435033924R1
R7055	C-CARBON R	RN72K1J-104JE	435031044R1
R7056	C-CARBON R	RN72K1J-223JE	435032234R1
R7057	C-CARBON R	RN72K1J-223JE	435032234R1
R7060	C-CARBON R	RN72K1J-101JE	435031014R1
R7062	C-CARBON R	RN72K1J-101JE	435031014R1

R7065	C-CARBON R	RN72K1J-103JE	435031034R1
R7067	C-CARBON R	RN72K1J-101JE	435031014R1
R7068	C-CARBON R	RN72K1J-332JE	435033324R1
R7069	C-CARBON R	RN72K1J-101JE	435031014R1
R7101	C-CARBON R	RN72K1J-750JE	435037504R1
R7102	C-CARBON R	RN72K1J-750JE	435037504R1
R7103	C-CARBON R	RN72K1J-750JE	435037504R1
R7104	METAL R	RNU1/2WCJ-4.7	453530474T
R7502	C-CARBON R	RN72K1J-000JE	435030004R1
R7503	C-CARBON R	RN72K1J-000JE	435030004R1
R7504	C-CARBON R	RN72K1J-000JE	435030004R1
R7505	C-CARBON R	RN72K1J-000JE	435030004R1
R7506	C-CARBON R	RN72K1J-000JE	435030004R1
R7507	C-CARBON R	RN72K1J-000JE	435030004R1
R7509	C-CARBON R	RN72K1J-000JE	435030004R1
R7511	C-CARBON R	RN72K1J-000JE	435030004R1
R7512	C-CARBON R	RN72K1J-000JE	435030004R1
R8001	C-CARBON R	RN72K1J-104JE	435031044R1
R8004	C-CARBON R	RN72K1J-391JE	435033914R1
R8005	C-CARBON R	RN72K1J-471JE	435034714R1
R8006	C-CARBON R	RN72K1J-821JE	435038214R1
R8007	C-CARBON R	RN72K1J-102JE	435031024R1
R8008	C-CARBON R	RN72K1J-182JE	435031824R1
R8009	C-CARBON R	RN72K1J-000JE	435030004R1
R8014	C-CARBON R	RN72K1J-272JE	435032724R1
R8015	C-CARBON R	RN72K1J-391JE	435033914R1
R8016	C-CARBON R	RN72K1J-821JE	435038214R1
R8017	C-CARBON R	RN72K1J-103JE	435031034R1
R8018	C-CARBON R	RN72K1J-104JE	435031044R1
R8019	C-CARBON R	RN72K1J-000JE	435030004R1
R8020	C-CARBON R	RN72K1J-331JE	435033314R1
R8021	C-CARBON R	RN72K1J-331JE	435033314R1
R8028	C-CARBON R	RN72K1J-333JE	435033334R1
R8029	C-CARBON R	RN72K1J-000JE	435030004R1
R8030	C-CARBON R	RN72K1J-103JE	435031034R1

R8031	C-CARBON R	RN72K1J-222JE	435032224R1
R8032	C-CARBON R	RN72K1J-222JE	435032224R1
R8033	C-CARBON R	RN72K1J-103JE	435031034R1
R8034	C-CARBON R	RN72K1J-333JE	435033334R1
R8040	C-CARBON R	RN72K1J-272JE	435032724R1
R8041	C-CARBON R	RN72K1J-272JE	435032724R1
R8042	C-CARBON R	RN72K1J-100JE	435031004R1
R8043	C-CARBON R	RN72K1J-272JE	435032724R1
R8044	C-CARBON R	RN72K1J-100JE	435031004R1
R8045	C-CARBON R	RN72K1J-470JE	435034704R1
R8047	C-CARBON R	RN72K1J-471JE	435034714R1
R8048	C-CARBON R	RN72K1J-470JE	435034704R1
R8049	C-CARBON R	RN72K1J-272JE	435032724R1
R8050	C-CARBON R	RN72K1J-391JE	435033914R1
R8051	C-CARBON R	RN72K1J-471JE	435034714R1
R8052	C-CARBON R	RN72K1J-821JE	435038214R1
R8053	C-CARBON R	RN72K1J-101JE	435031014R1
R8054	C-CARBON R	RN72K1J-152JE	435031524R1
R8055	C-CARBON R	RN72K1J-101JE	435031014R1
R8056	C-CARBON R	RN72K1J-561JE	435035614R1
R8057	C-CARBON R	RN72K1J-561JE	435035614R1
R8059	C-CARBON R	RN72K1J-471JE	435034714R1
R8060	C-CARBON R	RN72K1J-103JE	435031034R1
R8061	C-CARBON R	RN72K1J-391JE	435033914R1
R8062	C-CARBON R	RN72K1J-471JE	435034714R1
R8063	C-CARBON R	RN72K1J-821JE	435038214R1
R8064	C-CARBON R	RN72K1J-102JE	435031024R1
R8065	C-CARBON R	RN72K1J-182JE	435031824R1
R8501	C-CARBON R	RN72K1J-000JE	435030004R1
R8502	C-CARBON R	RN72K1J-000JE	435030004R1
R8503	C-CARBON R	RN72K1J-000JE	435030004R1
R8504	C-CARBON R	RN72K1J-000JE	435030004R1
R8506	C-CARBON R	RN72K1J-000JE	435030004R1
R8507	C-CARBON R	RN72K1J-000JE	435030004R1
R8508	C-CARBON R	RN72K1J-000JE	435030004R1

S7001	PUSH SW	NPS-111-S679	25035716
S7002	PUSH SW	NPS-111-S679	25035716
S7003	PUSH SW	NPS-111-S679	25035716
S8001	PUSH SW	NPS-111-S681	25035718T
S8002	PUSH SW	NPS-111-S681	25035718T
S8003	PUSH SW	NPS-111-S681	25035718T
S8004	PUSH SW	NPS-111-S681	25035718T
S8005	PUSH SW	NPS-111-S681	25035718T
S8006	PUSH SW	NPS-111-S681	25035718T
S8008	PUSH SW	NPS-111-S681	25035718T
S8009	PUSH SW	NPS-111-S681	25035718T
S8032	PUSH SW	NPS-111-S681	25035718T
S8033	PUSH SW	NPS-111-S681	25035718T
S8034	PUSH SW	NPS-111-S681	25035718T
S8035	PUSH SW	NPS-111-S681	25035718T
S8036	PUSH SW	NPS-111-S681	25035718T
S8037	PUSH SW	NPS-111-S681	25035718T
S8038	PUSH SW	NPS-111-S681	25035718T
S8039	PUSH SW	NPS-111-S681	25035718T
S8040	PUSH SW	NPS-111-S681	25035718T
S8041	PUSH SW	NPS-111-S681	25035718T
S8042	PUSH SW	NPS-111-S681	25035718T
X8001	CERA LOCK	CSTLS5M00G56-A0	3010406T

Integra Division of

ONKYO CORPORATION

Sales & Product Planning Div. : 2-1, Nisshin-cho, Neyagawa-shi, OSAKA 572-8540, JAPAN

Tel: 072-831-8023 Fax: 072-831-8163 <http://www.onkyo.com/>

Integra Division of

ONKYO U.S.A. CORPORATION

18 Park Way, Upper Saddle River, N.J. 07458, U.S.A.

Tel: 201-785-2600 Fax: 201-785-2650 <http://www.integrahometheater.com>