

Integra® SERVICE MANUAL

DVD PLAYER

DPS-5

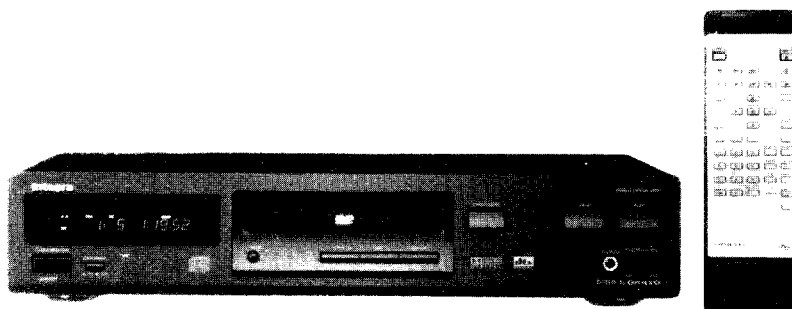

Black model 120V AC, 60Hz

SAFETY-RELATED COMPONENT WARNING!!

COMPONENTS IDENTIFIED BY MARK \triangle ON THE SCHEMATIC DIAGRAM AND IN THE PARTS LIST ARE CRITICAL FOR RISK OF FIRE AND ELECTRIC SHOCK. REPLACE THESE COMPONENTS WITH ONKYO PARTS WHOSE PART NUMBERS APPEAR AS SHOWN IN THIS MANUAL.

MAKE LEAKAGE-CURRENT OR RESISTANCE MEASUREMENTS TO DETERMINE THAT EXPOSED PARTS ARE ACCEPTABLY INSULATED FROM THE SUPPLY CIRCUIT BEFORE RETURNING THE APPLIANCE TO THE CUSTOMER.

TABLE OF CONTENTS

Service safety precautions/ Specifications-----	2
Front panel/ Rear panel views-----	3
Display view/ Remote controller views-----	4
Microprocessor terminal description-----	5
Exploded view parts list-----	6
Exploded view-----	7-8
IC Block diagram-----	9
Firmware upgrade-----	10-11
Memo-----	12
Printed circuit board view-----	13-16
Schematic diagram-----	17-22
Printed circuit board parts list-----	23-24
Main PC board view-----	25-28
DVD mechanism view-----	29
DVD mechanism/ Main PC board parts list-----	30
Replacement mechanical parts-----	31-35
Trouble shooting-----	36-43
Wiring diagram-----	44
Assemble the packing form-----	45-46
Packing view-----	47

OPERATING INSTRUCTIONS

SAFETY PRECAUTIONS

	WARNING RISK OF ELECTRIC SHOCK DO NOT OPEN	
AVIS	RISQUE DE CHOC ELECTRIQUE NE PAS OUVRIR	
WARNING : TO REDUCE THE RISK OF ELECTRIC SHOCK, DO NOT REMOVE COVER (OR BACK). NO USER SERVICEABLE PART INSIDE. REFER SERVICING TO QUALIFIED SERVICE PERSONNEL.		

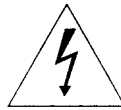

The lightning flash with arrowhead symbol, within an equilateral triangle, is intended to alert the user to the presence of uninsulated "dangerous voltage" within the product's enclosure that may be of sufficient magnitude to constitute a risk of electric shock to persons.



The exclamation point within an equilateral triangle is intended to alert the user to the presence of important operating and maintenance (servicing) instruction in the literature accompanying the appliance.

WARNING : TO REDUCE THE RISK OF FIRE OR ELECTRIC SHOCK, DO NOT EXPOSE THIS APPLIANCE TO RAIN OR MOISTURE. DANGEROUS HIGH VOLTAGES ARE PRESENT INSIDE THE ENCLOSURE. DO NOT OPEN THE CABINET. REFER SERVICING TO QUALIFIED PERSONNEL ONLY.

CAUTION : TO PREVENT ELECTRIC SHOCK, MATCH WIDE BLADE OF PLUG TO WIDE SLOT, FULLY INSERT.

ATTENTION : POUR EVITER LES CHOCS ELECTRIQUE, INTRODUIRE LA LAME LA PLUS LARGE DA LA FICHE DANS LA BORNE CORRESPONDANTE DA LA PRISE ET POUSSER JUSQU' AU FOND.

PRECAUTIONS

Replacing the fuses

For continued protection against risk fire, replace only with same type and same rating fuse.

CIRCUIT No.	PART No.	DESCRIPTION
F901 <UD>	252146	1.25A-TSC
F901 <UP/UWT,UPA>	252071	1.25A-SE-EAWK

This symbol located near the fuse indicates that the fuse used is fast operating type. For continued protection against fire hazard, replace with same type fuse. For fuse rating refer to the marking adjacent to the symbol.

Ce symbole indique que le fusible utilise est a rapide. Pour une protection permanente, n'utiliser que des fusibles de meme type. Ce dernier est indique la qu le present symbol est appose.

LASER BEAM CAUTION LABEL

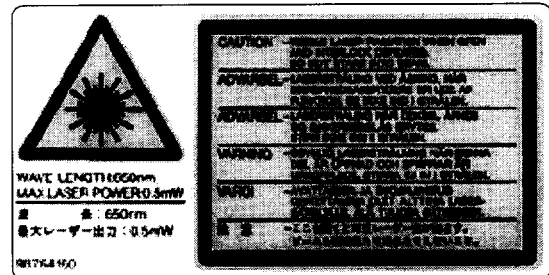

When the power supply is being turned on, you may not remove this laser cautions label, radiation of a laser may be received. Pickup Head consists of a laser diode that is very susceptible to external static electricity. Although it operates properly after replacement, if it was subject to electrostatic discharge during replacement, its life might be shortened. When replacing, use a conductive mat, soldering iron with ground wire, etc. to protect the laser diode from damage by static electricity. And also, the LSI and IC are same as above.

SPECIFICATIONS

DVD Player

Power supply	UD : AC 120 V, 60Hz UP, UPA : AC230 V, 50Hz UWT: AC220V-230V, 50/60Hz
Power consumption	25 W
Weight	2.8 kg, 8.4lbs.
External dimensions	45 x 91 x 306 mm(W/H/D), 17-1/8" x 3-9/16" x 12-1/16" (W/H/D)
Signal system	Standard NTSC
Laser	Semiconductor laser, wavelength 650nm
Frequency range(digital audio)	DVD linear sound: 48 kHz sampling 4 Hz to 22 kHz 96 kHz sampling 4 Hz to 44 kHz Audio CD : 4 Hz to 20 kHz
Signal to noise ratio(digital audio)	More than 90 dB (EIAJ)
Audio dynamic range(digital audio)	More than 87 dB (EIAJ)
Harmonic distortion(digital audio)	Less than 0.1 %
Wow and flutter	Below measurable level (less than ±0.001 % (W.PEAK)) (EIAJ)
Operating conditions	Temperature : 5 °C to 35 °C(41 to 95 Degree), Operation status: Horizontal

Outputs

Video output	1.0 V (p-p), 75 Ω, negative sync., pin jack x 1
S video output	(Y) 1.0 V (p-p), 75 Ω (C) 0.286 V (p-p), 75 Ω
Color different output	(Y) 1.0 V (p-p), 75 Ω, negative sync., pin jack x 1 (Cb)(Cr) 0.7 V (p-p), 75 Ω
Audio output (Optical audio)	Optical connector x 1
Audio output (Digital audio)	0.5 V (p-p), 75 Ω, pin jack x 1
Audio output (Analog audio)	2.0 V (rms), 470 Ω, pin jack(L, R) x 1
Headphone terminal	32 Ω (10mW), Impedance; more than 8 Ω

* Designs and specifications are subject to change without notice.

MICROPROCESSOR TERMINAL DESCRIPTION

PIN No.	TERMINAL	I/O	DESCRIPTION	PIN No.	TERMINAL	I/O	DESCRIPTION
1	7G	O	Grid output pins	30	AVREF	I	Reference voltage terminal for A/D converter
2	6G	O	Grid output pins	31	XT1	I	To connect the VSS terminal
3	5G	O	Grid output pins	32	XT2	O	Not used
4	4G	O	Grid output pins	33	VSS	I	Vss
5	3G	O	Grid output pins	34	X1	I	Crystal connection terminal for main system
6	2G	O	Grid output pins	35	X2	O	Crystal connection terminal for main system
7	1G	O	Grid output pins	36	P37	O	Not used
8		-	Power supply pin (+VDD)	37	BUZZER	O	Buzzer signal output terminal
9	DVDPOFF	O	Not used	38	STANDBY_LED	O	Control the standby indicator
10	DVDPOWER	O	Not used	39	POWER_LED	O	Control the Power indicator (Not used)
11	STBYX	O	Strobe signal output terminal	40	TII	O	Not used
12	DVCS	O	Not used	41	TO2	O	Not used
13	DSTBX	I	Main strobe output signal	42	TO1	O	Not used
14	DSPCKX	I	Main clock output signal	43	~SYSOUT	O	RI system code output terminal
15	DSPSI	O	To change the main input signal from the sub output signal	44	SYSIN	I	RI system code input terminal
16	DSPSO	I	To change the sub output signal from the main input signal	45	~POFF	O	Not used
17	DSPRST	I	Reset terminal	46	INTP1	O	Not used
18		O	Not used	47	~REMIN	I	Input terminal of the remote control sensor
19		O	Not used	48	IC	I	Internal connection pin
20	AVSS	I	Ground terminal for A/D converter	49	P72	O	Not used
21	ANI7	O	Not used	50	P71	O	Not used
22	ANI6	O	Not used	51	P70	O	Not used
23	ANI5	O	Not used	52	VDD	I	Power supply pin (+VDD)
24	ANI4	O	Not used	53	FL_ON/OFF	O	Connect to the FL tube
25	ANI3	I	Analog input pin for A/D converter	54		O	Not used
26	ANI2	I	Analog input pin for A/D converter	55		O	Not used
27	K1	I	Operation switch connection terminal	56		O	Not used
28	K0	I	Operation switch connection terminal	57		O	Not used
29	AVDD	I	Analog power supply terminal for A/D converter	58-70	P1	O	Segment output pins
				71	VKK-24V	I	Power supply pin for FL controller
				72-74	P14	O	Segment output pins
				75-80	13G	O	Grid output pins

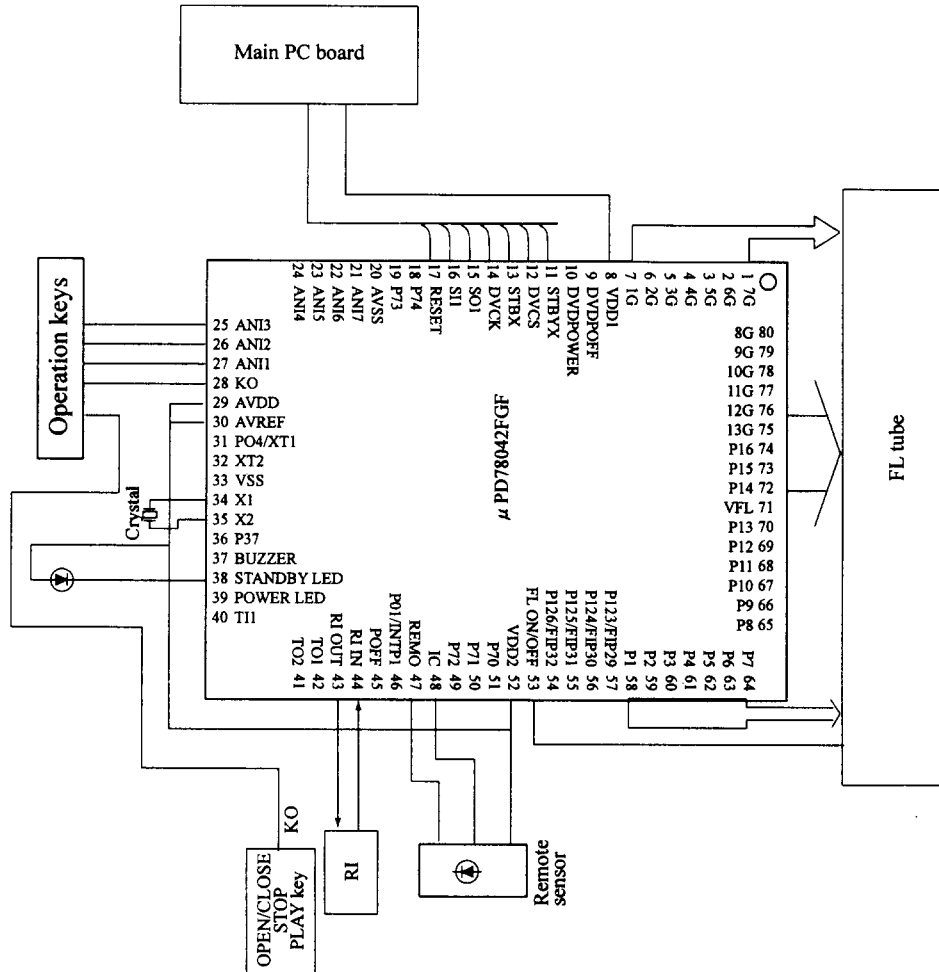

EXPLODED PARTS LIST

REF. No.	PARTS No.	DESCRIPTION	REF. No.	PARTS No.	DESCRIPTION
A001	27111130B	Front bracket	A305	27212128	Front panel
A003	27150441	Shield plate, (F)	A306	28135275	Badge (Integra)
A005	28159040A	Decorative frame	E703	29362526	Label ROM
A006	27100378A	Chassis	E801	2045131512	NCFC5-131512, Flexible flat cable
A007	29362541	Bottom label	E802	2045131012	NCFC5-131012, Flexible flat cable
A008	27190266	KGLS-12RF, Holder	E803	2044190102	NCFC5-190102, Flexible flat cable
A011	27150440A	Shield plate	E804	260208	Wire tie
A012	29110083	Cloth tape	E805	2042183012	NCFC2-183012, Flexible flat cable
A014	27225143	Shield case	E806	2042081012	NCFC2-081012, Flexible flat cable
A201	28191865	Clear plate	E807	2047061212	NCFC7-061212, Flexible flat cable
A203	28148418	Door (Tray)	F901	△ 252146	1.25A-TSC,Fuse
A204	27262643	Plate, DVD	P901	△ 253295KAW	AS-UC-1#18, Power supply cord
A206	28198864	Facet	U01	1H417599-2	NAPS-6699-2, Power supply circuit PC board ass
A209	28325687	Knob, POWER	U02	1H417500-2	NAAF-6700-2, Output Terminal PC board ass'y
A210	27273121B	Joint, POWER	U03	1H417501-2	NADIS-6701-2, Display circuit PC board ass'y
A212	28325452	Knob, PHONE	U04	1H417502-2	NASW-6702-2, Open/close switch PC board ass'y
A214	28184764	Top cover	U05	1H417503-2	NAETC-6703-2, Headphone terminal PC board as
A217	27175311A	Leg ass'y	U06	1H417504-2	NAETC-6704-2, Inlet terminal PC board
A301	27122644	Rear panel	U10	24150006	SD-20B1, Main PC board ass'y
A215	838430088	3TTB+8B(BC), Self-tapping screw	A701	24801002	SD-2109K2-ZX, DVD Mechanism
A019	831430088	3TTW+8B(BC), Self-tapping screw			
A002	838130088	3TTB+8B, Self-tapping screw			
A303	838440089	4TTB+8C(BC), Self-tapping screw			

NOTE:
 THE COMPONENT IDENTIFIED BY MARK △
 ARE CRITICAL FOR RISK OF FIRE AND
 ELECTRIC SHOCK. REPLACE ONLY WITH
 PART NUMBER SPECIFIED.

UNLOADED VIEW

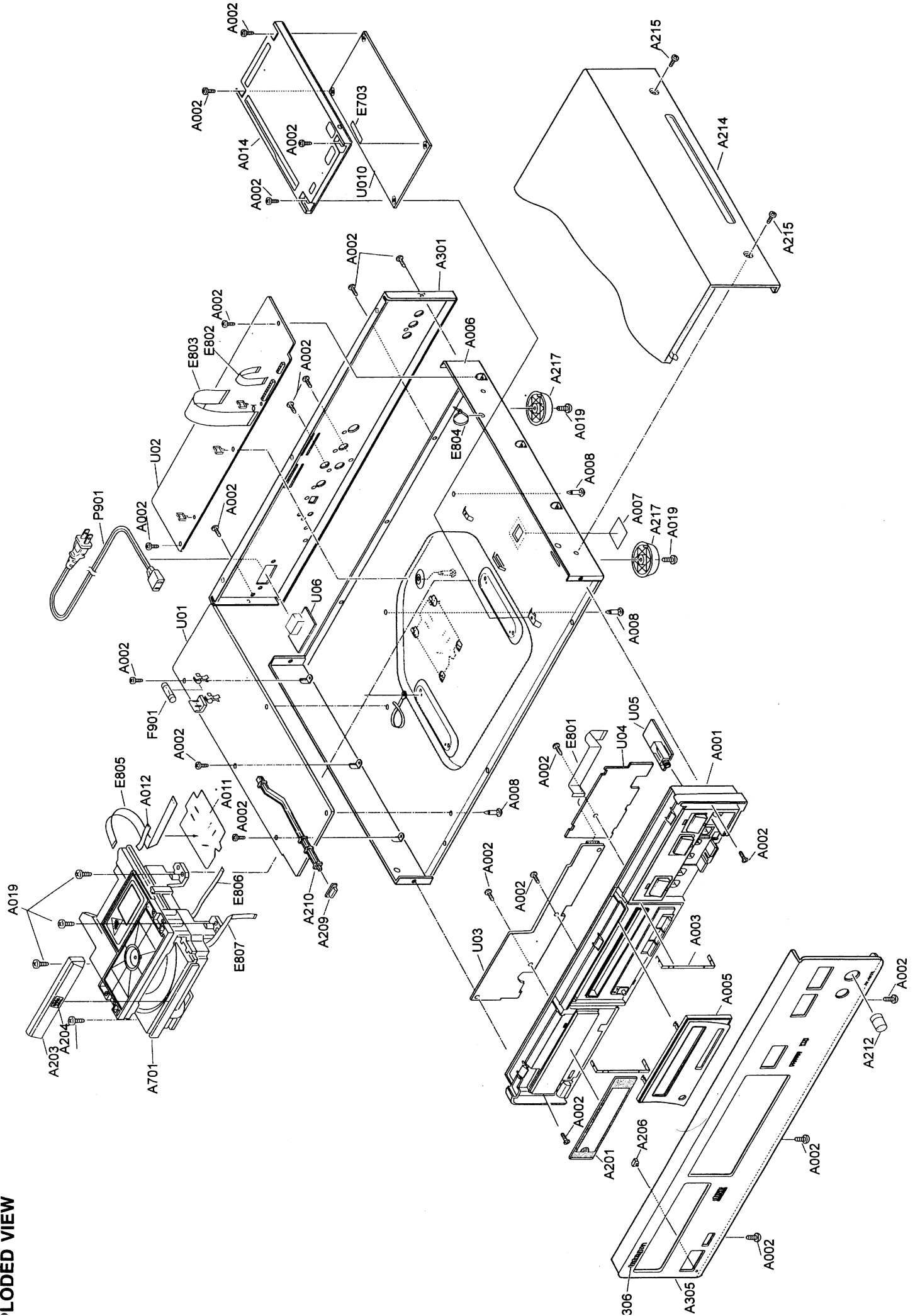

When Upgraded Firmware

1. When the firmware is upgraded, rewriting the new firmware into IC615 may be requested for servicing.
2. Connect a computer to the main PC board of the DVD video player with using UPGRADED FIRMWARE KIT (P/No. 0P37)

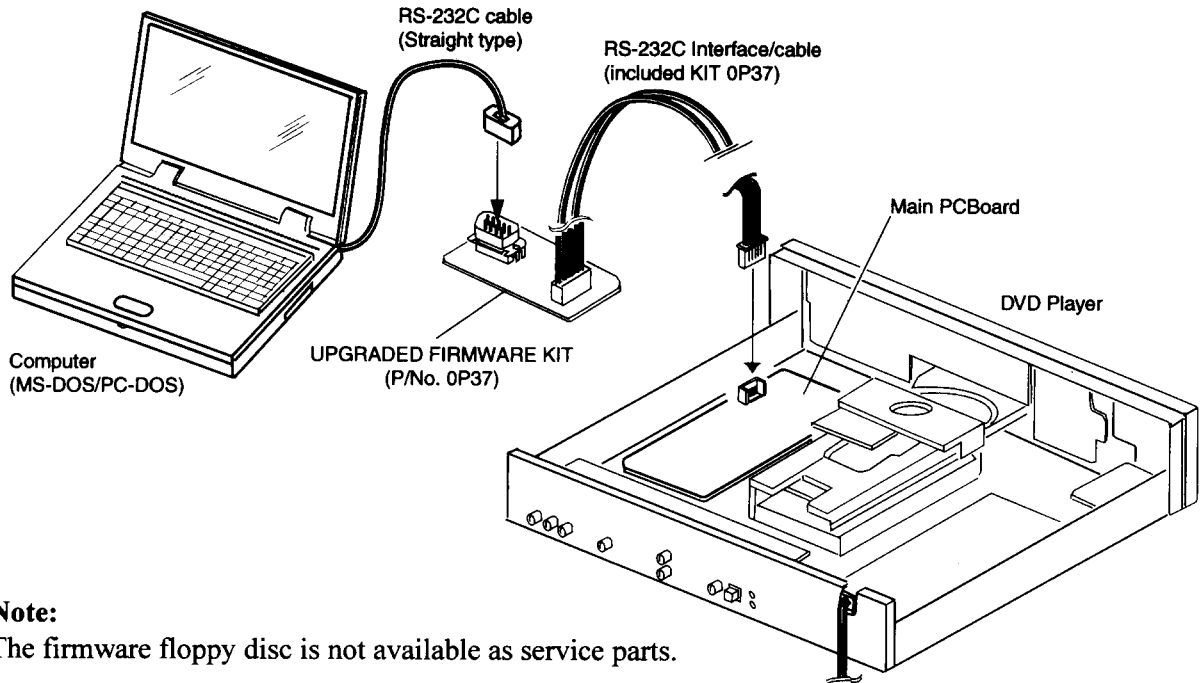

Note:
The firmware floppy disc is not available as service parts.

3. Writing of firmware (all destinations) in main board

- 3-1 The power supply is turned on and press the STANDBY/ON button to turn on the DVD player.
- 3-2. Connect a computer to the main PC board of the DVD video player with using UPGRADED FIRMWARE KIT (P/No. 0P37)
- 3-3. The program for the data writing is executed with the personal computer.
- 3-4. Type the following command in DOS prompt mode.
Flash5 "firmware filename"
- 3-5. Select [1.WRITE] when the MENU appeared on your screen.

```

C:\> flash5 v3100 v34
-----
Flash Writer Ver5.0 (c)TOSHIBA 1997
Please Select Mode: 1.WRITE 2.VERIFY 3.WRITE&VERIFY E.End
    
```

After about 10 min.

<screen>

```

00000000000000000000000000000000
ALL CHECK SUM (Send: 0xF8AC340E vs Receive: 0xF8AC340E)----0000
Continue? [Y/N]
    
```

It is confirmed that the end of ALL CHECK SUM is "0000". (Write it again, except for this)

4. Confirmation of content of writing

4-1. The "STOP" key and the "SKIP-DOWN" key are pushed at the same time in the state of No Disc.

4-2. It is confirmed that the display of monitor is as follows.

USA area

```

ROM Version V*.*** -R1
OSD      ENG/FRE/SPA
VCD      ON      BUZZER    OFF
A.3D     OFF     RANDOM    ON
KARA     OFF     DTS      ON
VOCAL    SETUP   DIMMER   3TYP
C.S.     ON      V-FMT    NTSC
JOG      OFF     MPEG-A   ON
V.3D     ON

```

5. Display confirmation of FL tube

All lighting of the FL tube only while "STOP" is being pushed when "STOP" key is pushed while pushing "SKIP-UP" key to the main body key.

6. Setting of the first setup screen mode

6-1. The "STOP" key and the "DIMMER" key on the main body key are pushed at the same time in the state of No Disc.

6-2. It is confirmed that the Setup screen goes out, and the character of "First Setup ON" has come out in lower right.

6-3. The power supply again by On after turning off the power supply, and it is confirmed that the first setup screen goes out by Standby/ON mode. (Never push the Setup key here)

6-4. The power supply is turned off, and the AC code is pulled out.

7. Others

7-1. The factory setting of DIMMER must be normal.

7-2. The hollow becomes the horizontal position at the position of JOG by factory setting.

Factory setting confirmation

"SETUP" as follows each setting of the screen is confirmed.

USA area

LANGUAGE SETTING	
On-Screen Language	ENG
Disc Menu Language	ENG
Audio Language	ENG
Sub Title	---

PICTURE	
TV Shape	4:3LB
Black Level	Enh.

AUDIO	
Audio out sel. Anal 2ch	

CHEMATIC DIAGRAM

A B C D E F G

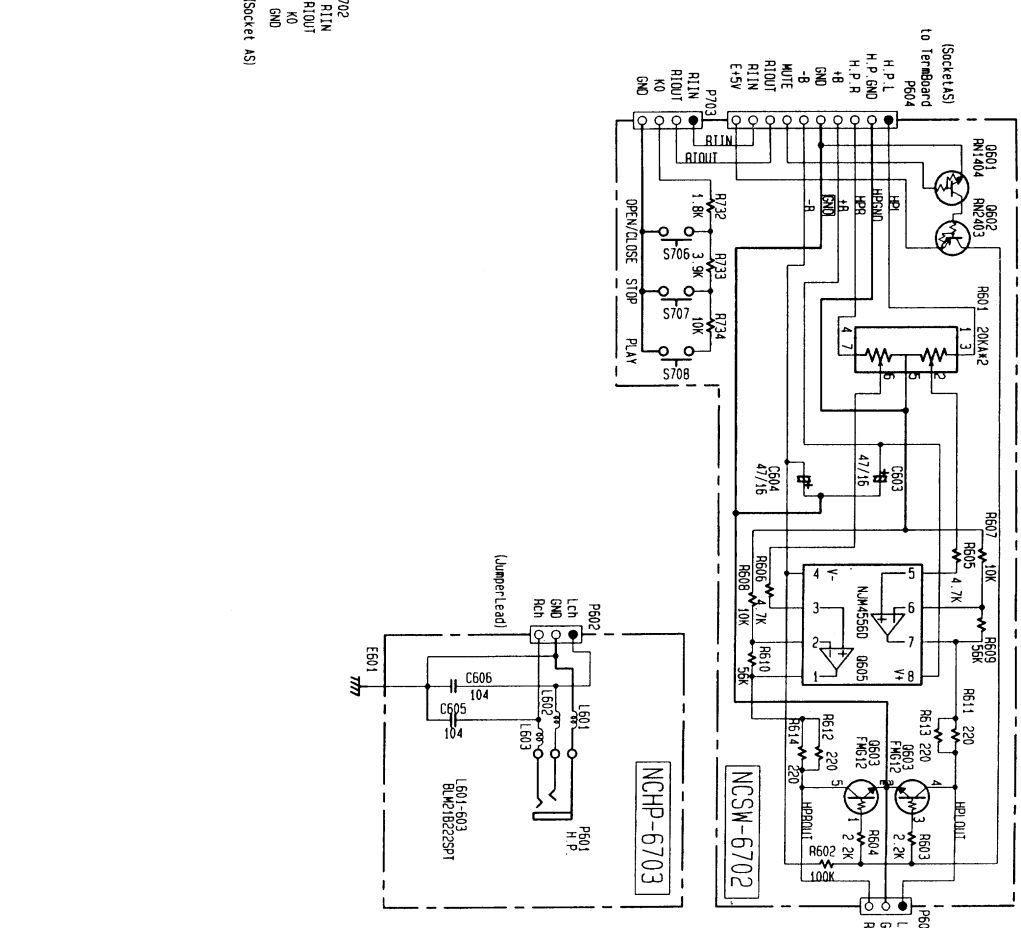
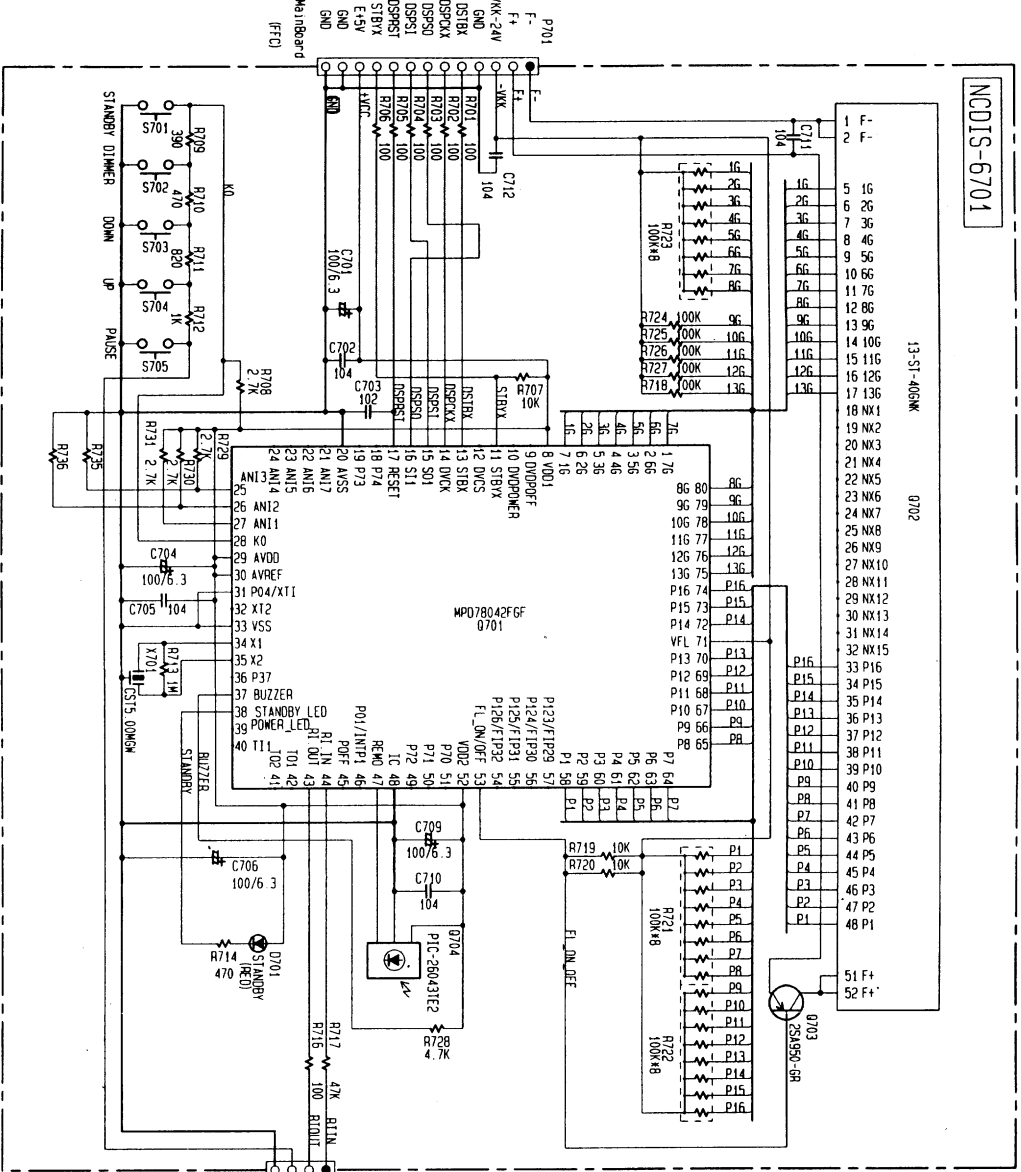

NOTE
 THE COMPONENTS IDENTIFIED BY MARK Δ ARE CRITICAL FOR SAFETY.
 REPLACE ONLY WITH PART NUMBER SPECIFIED.
 VOLTAGE MEASURED WITH VOLTMETER. \square IS DC VOLTAGE (NO INPUT SIGNAL).
 ALL PNP TRANSISTORS ARE EQUIVALENT TO 2SA1015-SR UNLESS OTHERWISE NOTED.
 ALL NPN TRANSISTORS ARE EQUIVALENT TO 2SC1815-SR UNLESS OTHERWISE NOTED.
 ALL DIODES ARE EQUIVALENT TO 1SS133 UNLESS OTHERWISE NOTED.
 ELECTROLYTIC CAPACITORS (\square) ARE IN μ F/V.
 ALL CAPACITORS ARE IN OF/50WV UNLESS OTHERWISE NOTED.
 ALL RESISTORS ARE IN OHMS \square /4Watts UNLESS OTHERWISE NOTED.
 EX) 030-9P 330-330P 331-330P 333-0 0334F
 THE THICK LINES ON PC BOARD ARE THE PRINTING SIDE OF THE PARTS
 EX) \square PRINTING SIDE
 CIRCUIT IS SUBJECT TO CHANGE FOR IMPROVEMENT.

SCHEMATIC DIAGRAM

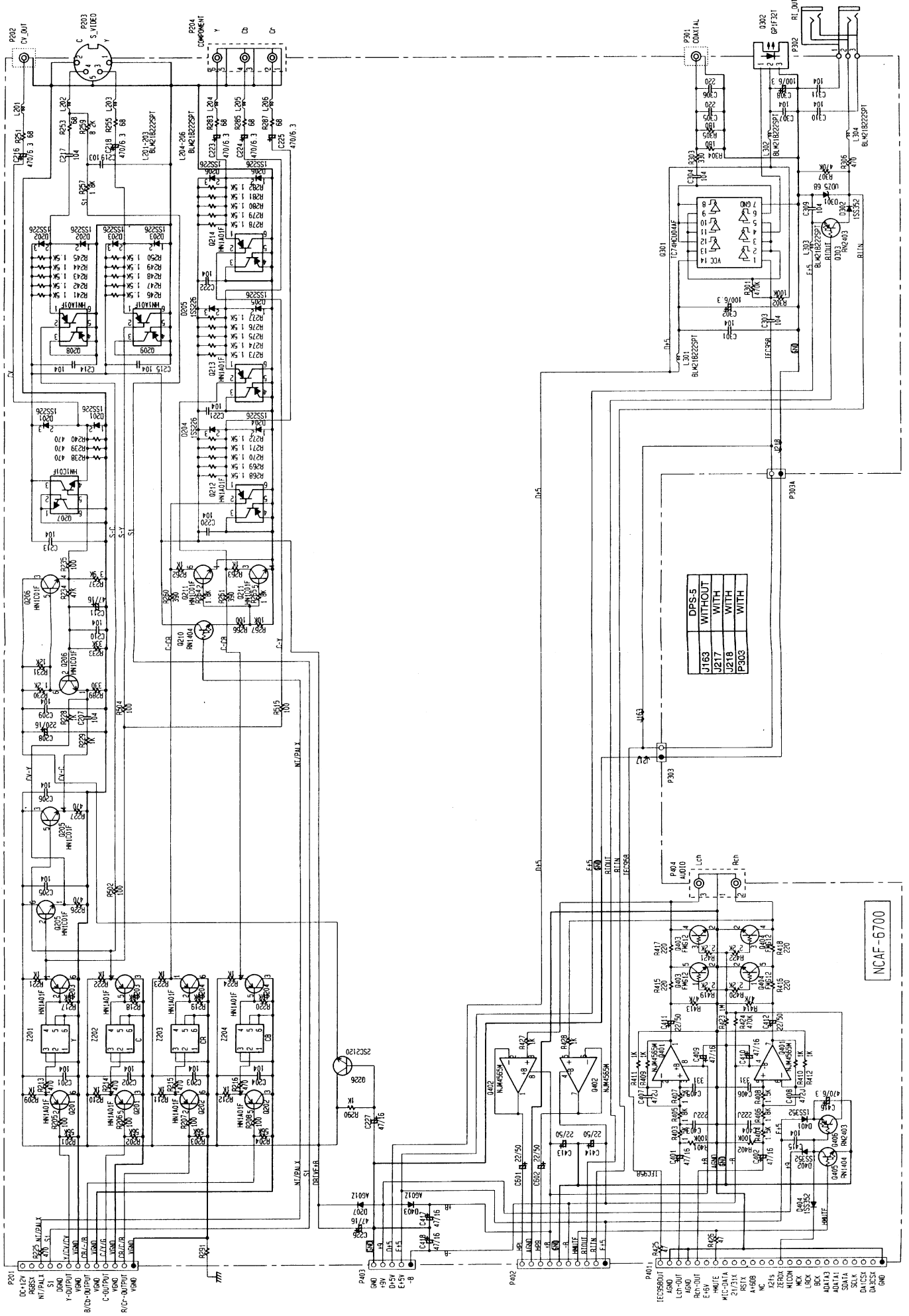

CHEMATIC DIAGRAM

NCP5-6699

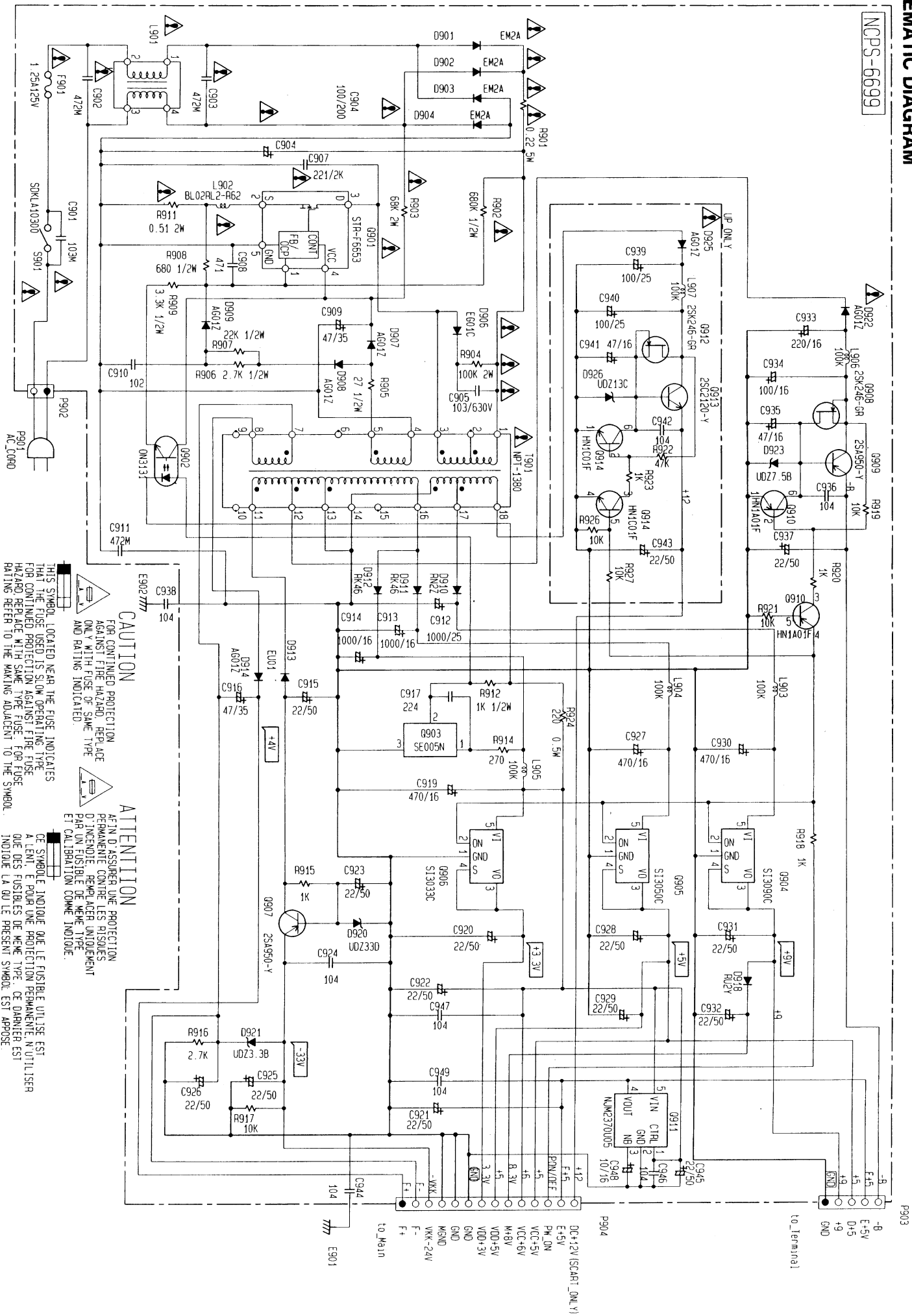

CAUTION
 FOR CONTINUED PROTECTION
 AGAINST FIRE HAZARD, REPLACE
 ONLY WITH FUSE OF SAME TYPE
 AND RATING INDICATED.

ATTENTION
 AFIN D'ASSURER UNE PROTECTION
 PERMANENTE CONTRE LES RISQUES
 D'INCENDIE, REMPLACER UNIQUEMENT
 PAR UN FUSIBLE DE MÊME TYPE
 ET CALIBRÉ COMME INDICÉ.

THIS SYMBOL LOCATED NEAR THE FUSE INDICATES
 THAT THE FUSE USED IS SLOW OPERATING TYPE
 FOR CONTINUED PROTECTION AGAINST FIRE HAZARD
 HAZARD REPLACE WITH SAME TYPE FUSE FOR FUSE
 RATING REFER TO THE MAKING ADJACENT TO THE SYMBOL.

A B C D E F G

PC BOARD PARTS LIST

Power supply circuit PC board ass'y

CIRCUIT No.	PART No.	DESCRIPTION
	ICs	
Q901	△ 22241229	STR-F6653
Q904	22241230	SI3090C
Q905	22241231	SI3050C
Q906	22241232	SI3033C
Q903	22241233	SE005N
Q911	22241289R2	NJM2370U05
	Transistors	
Q907,Q909	2211504 or	2SA950-Y or
Q907,Q909	2211503	2SA950-O
Q908	2211945	2SK246-GR
Q910	2215915R2	HN1A01F-GR
	Diodes	
D901-D904	△ 22380287F	EM2A
D910	22380295F	RN2Z
D911,D912	22380296F	RK46
D918	22380300F	RU2YX
D921	224490330R2	UDZ3.3B
D923	224490750R2	UDZ7.5B
D920	224493300R2	UDZ33B
D906	△ 22380291	EG01C
D907-D909, D914	22380294	AG01Z
D922	△ 22380294	AG01Z
D913	22380297	EU01
	Photo coupler	
Q902	24120044	ON3131-R
	Coils	
L902	230906	BL02RN2-R62,FR core
L903-L906	231253K100	NCH-1490,Choke coil
L901	△ 231280	NCH-3561,Choke coil
	Resistors	
R912	443521024	1k ohm,1/2W,Metal oxide
R913	443522204	22 ohm,1/2W,Metal oxide
R924	443522214	220 ohm,1/2W,Metal oxide
R907	443522234	22k ohm,1/2W,Metal oxide
R905	443522704	27 ohm,1/2W,Metal oxide
R906	443522724	2.7k ohm,1/2W,Metal oxide
R909	443523324	3.3k ohm,1/2W,Metal oxide
R908	443526814	680 ohm,1/2W,Metal oxide
R901	△ 4000076	0.22 ohm,5W,Metal plate
R902	△ 411516844	680k ohm,1/2W,Carbon
R904	△ 441721044NF	100k ohm,2W,Metal oxide
R903	△ 441726834NF	68k ohm,2W,Metal oxide
R910	4500163	0.47 ohm,1/4W,Metal
R911	△ 451735194F	0.51 ohm,2W,Metal
	Capacitors	
C905	△ 3000114S	0.01 μ F+/-10%,630V,Plastic(XJ C)
C907	△ 3000115	220pF+/-10%,2kV,Plastic(HR C)
C902,C903	△ 3500077	4700pF+/-20% 50V,Plastic(IS C)
C911	3500077	4700pF+/-20%50V,Plastic(IS C)
C901	△ 3500196S	0.01 μ F+/-20%,75V,Plastic(IS C)
C904	△ 3500198S	100 μ F,200V, Plastic(YXA C)
C913,C914	393341027S	1000 μ F+/-20%,16V,Plastic(VX)
C912	393751027S	1000 μ F+/-20%,25V,Plastic(PW)

CIRCUIT No.	PART No.	DESCRIPTION
	Power transformer	
T901	△ 2301432	NPT-1380
	Switch	
S901	△ 25035702	NPS-121-L665P
	Plug	
P902	25055675	NPLG-2P631
	Socket AS	
P903	2002341020	NSAS-10P0034
P904	2002A392840	NSAS-28P0772
	Crimp AS	
P906	2065543304	
P907	2065543309	
	Fuse holder	
F901	25050065	YSH403T
	Fuse label	
E910	29362309	1.25A/125V
	Heat sinks	
Q904A,Q905A, Q906A	27160145-1	RAD-51
Q901A	27160412	RAD-111
	Screws	
Q901B,Q904B, Q905B,Q906B	838430107	3TTB+10S(BC)
	Output Terminal PC board ass'y	
CIRCUIT No.	PART No.	DESCRIPTION
	IC	
Q301	222740046R1O	74HCU04(TC74HCU04F)
Q401,Q402, Q403	22241383R2	NJM4565M-D
	Transistors	
Q226	2211164 or	2SC2120-Y or
Q226 or	2211163	2SC2120-O
Q404	2215940R2	FMG12
Q201-Q209	2215915R2	HN1A01F-GR
Q211-Q214	2215925R2	HN1C01F-GR
Q210,Q405	2214490R2	RN1404
Q303,Q406	2214540R2	RN2403
	Diodes	
D201-D206	223266R2	1SS226
D302,D401, D402,D404	223234R2	1SS352,Chip
D207,D403	22380294	AG01Z
D301	224490560R2	UDZ5.6B,Zener
	Choke coils	
L201-L206, L301-L304	230921R2	BLM21B222SPT

CIRCUIT No.	PART No.	DESCRIPTION
	Photo coupler	
Q302	24120076	JFJ1000
	Jacks	
P202	25045591	NPJ-1PDYE402
P204	25045546	NPJ-3PDRE367
P301	25045592	NPJ-1PDOR403
P302	25045330	NPJ-2PDBL184
P404	25045593	NPJ-2PDWR404
	Plugs	
P402	25055154	NPLG-10P138
P403	25055149	NPLG-5P133
	Socket AS	
P303	2009990562	NSAS-4P0755
	Sockets	
P201	25051937	NSCT-13P1724
P401	25051949	NSCT-25P1736
P203	25051955	NSCT-4P1742
	Filters	
Z201-Z204	3030041	Y-5(8.00MHz),LC block

Display circuit PC board ass'y

CIRCUIT No.	PART No.	DESCRIPTION
	IC	
Q701	22241388R3	MPD78042GF-112-3B9
	Transistors	
Q703	2211504 or	2SA950-Y or
Q703 or	2211503	2SA950-O
	LED	
D701	225370	SLR-342VRTB7
	Remote sensor	
Q704	241330	PIC-26043TE2
	Switches	
S701-S705	25035699	NPS-111-S662
	FL tube	
Q702	212201	13-ST-40GNK
	Ceramic filter	
X701	3010242	CST5.00MGW
	Socket	
P701	25051895	NSCT-13P1682
	Plug	
P702	25055368	NPLG-4P351
	Others	
E701	27191085	FL holder

Open/close switch PC board ass'y

CIRCUIT No.	PART No.	DESCRIPTION
	IC	
Q605	222654	NJM4556D
	Transistors	
Q601	2214490R2	RN1404
Q602	2214540R2	RN2403
Q603	2215940R2	FMG12

CIRCUIT No.	PART No.	DESCRIPTION
	Switches	
S706-S708	25035699	NPS-111-S662
	Resistor	
R601	5132436	N14RGL20KA17Z,Variable
	Socket AS	
P604	2002A392055	NSAS-20P0749
P703	2002320810	NSAS-8P0025
	Other	
P603	25051107	NSCT-3P894,Wire holder
	Headphone terminal PC board ass'y	
	CIRCUIT No. PART No. DESCRIPTION	
N L601-L603	230921R2	BLM21B222SPT,Choke coil
P601	25045443	YKB26-5803,Head phone jack
P602	25051107	NSCT-3P894,Wire holder
	Inlet PC board ass'y	
	CIRCUIT No. PART No. DESCRIPTION	
P905	25055960	NPLG-2P913

NOTE: THE COMPONENT IDENTIFIDE BY MARK  ARE CRITICAL FOR RISK OF FIRE AND ELECTRIC SHOCK. REPLACE ONLY WITH PART NUMBER SPECIFIDE.

SCHEMATIC DIAGRAM (MAIN PC BOARD)

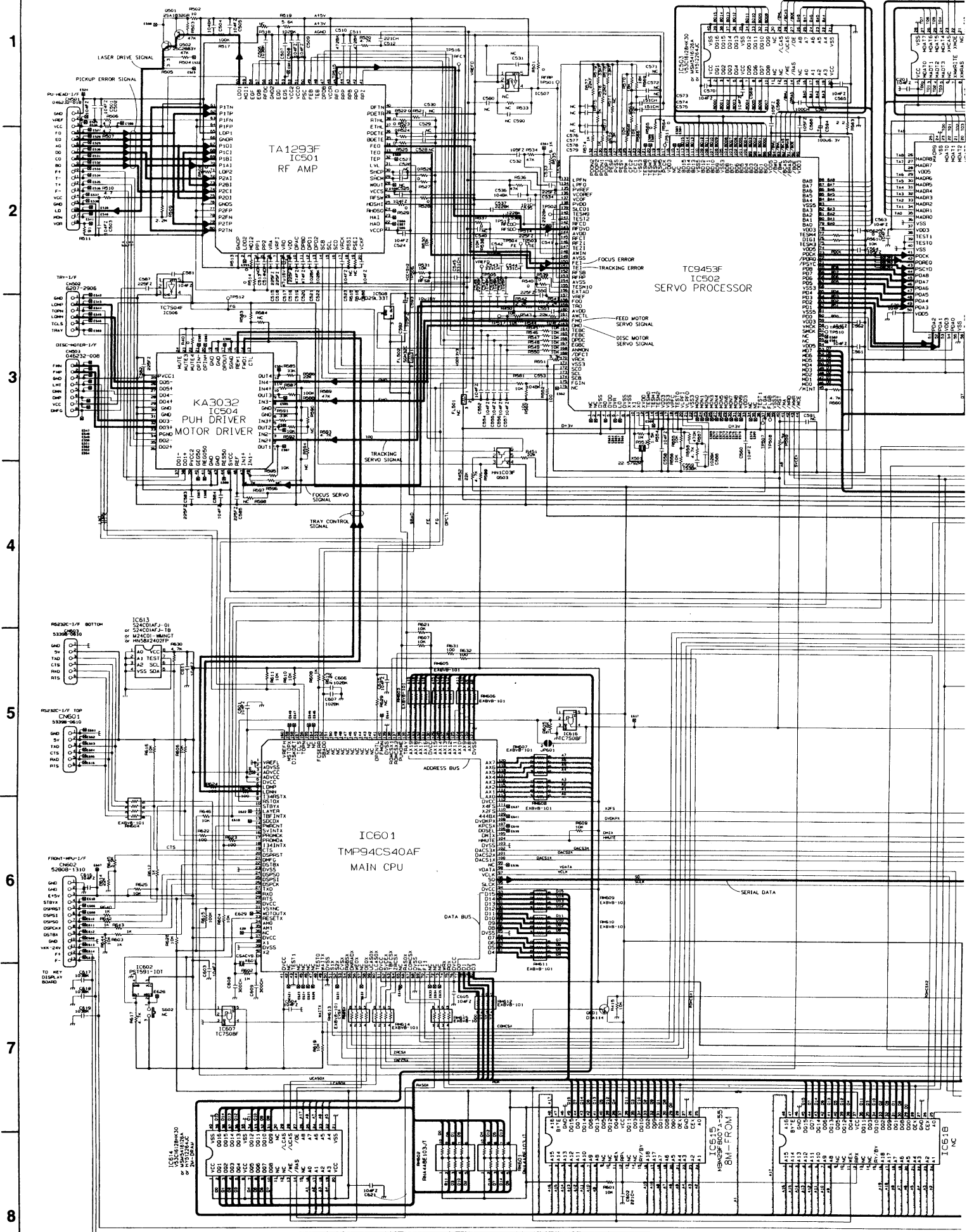

MECHANISM ASSEMBLY

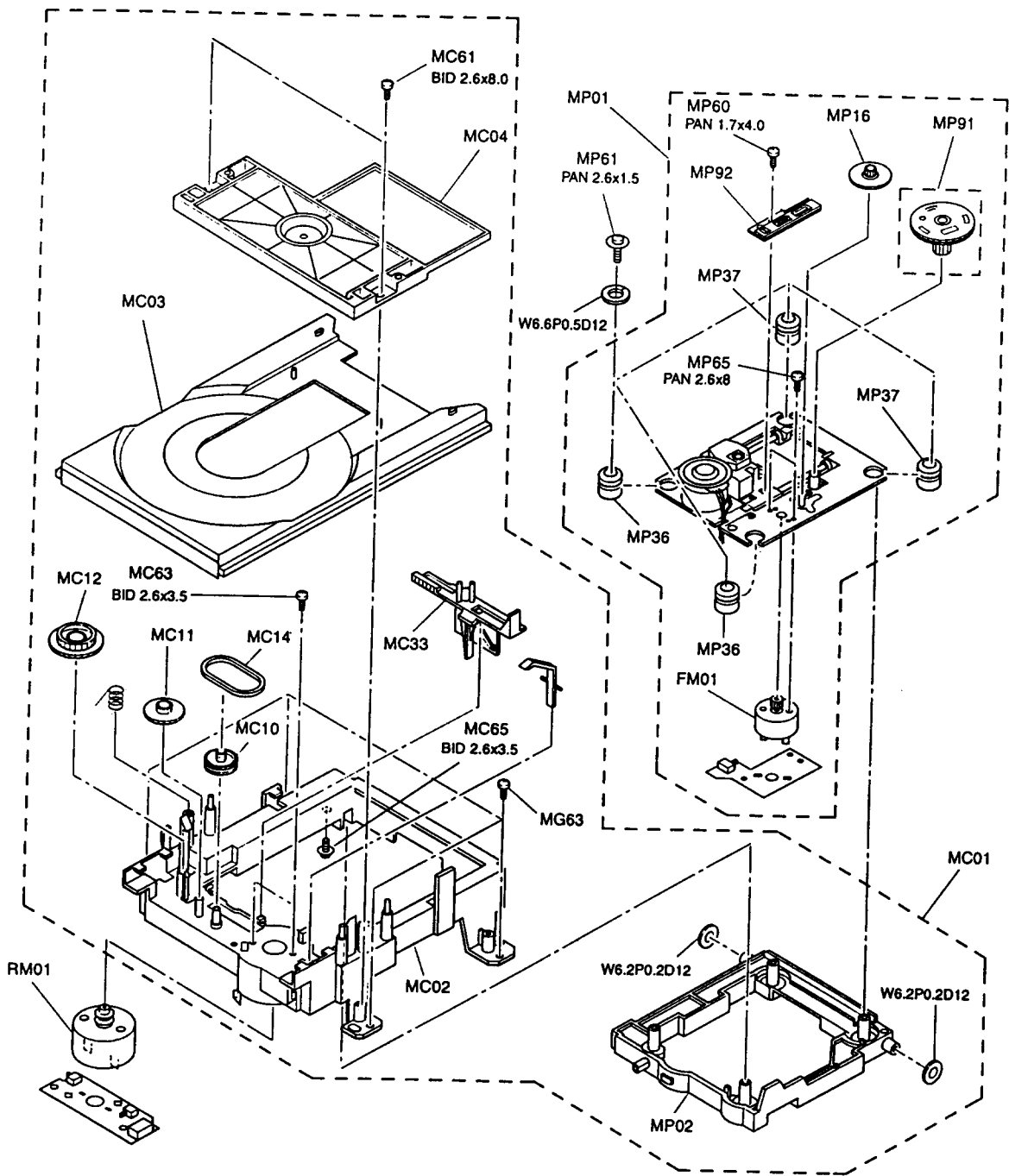

MECHANICAL PARTS LIST

REF. No.	CORD	DESCRIPTION
MP01	79070415	Mecha assy-pu
MP36	79070417	Rubber, Dumper, Front
MP37	79070418	Rubber, Dumper, Rear
MP91	79070419	Gear assy, Kit, B
MP92	79070420	Gear assy, Rack
FM01	79070421	Motor assy, Feed, DC
MP16	79070422	Gear A
RM01	79070427	Motor assy, Loading, DC
MC14	79070428	Belt, Load
MC01	79070416	Chassis assy, Mechanism

MAIN PC Board

EU01	79083019	PC Board assy Main PCB
------	----------	------------------------

1. REPLACEMENT OF MECHANICAL PARTS

Cabinet Replacement

1-1. Top Cover

1. Remove the top cover.

1-2. Clamper Stay

<Removal>

1. Remove two screws(1).
2. Release two claws and remove the clamper stay(2).

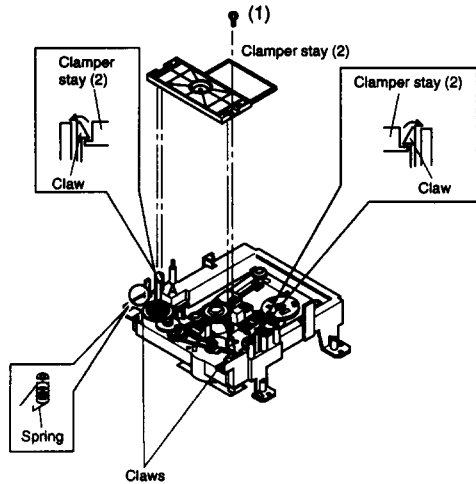

Fig. 1-1

<Mounting>

3. The spring for tray side pressure is inserted into the portion "A".
4. By referring to Fig 1-2, insert the spring normally and mount the clamper stay.

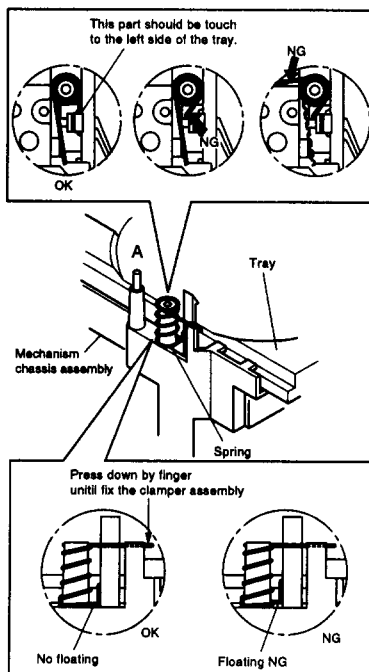

Fig. 1-2

1-3. Tray Eject

1. Slide the slider(2) of the mechanism chassis assembly (1) with a screwdriver, etc. in the arrow direction, so that the tray(3) is ejected.

Note:

Take care not to damage the pickup and other parts.

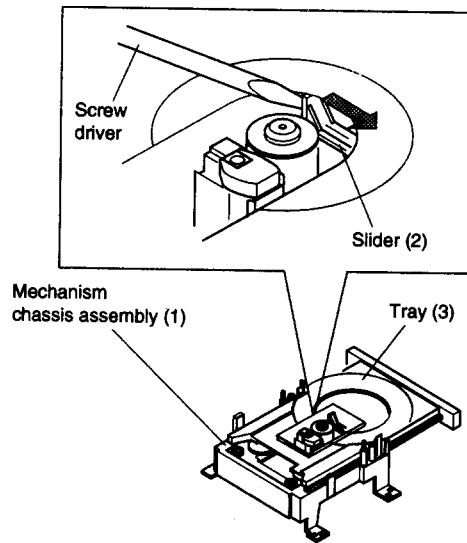

Fig. 1-3

1-4. Tray Panel Removal

1. Eject the tray(3).
2. Twist the tray panel(4) a little in the arrow A direction with the tray(3) hole by hand to release two claws and lift up tray panel (4) in the arrow B direction, then the tray panel(4) is removed.

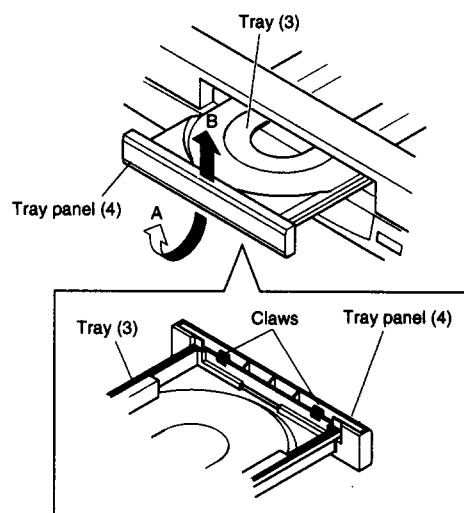

Fig. 1-4

Note

Insert the tray(3) with the front side of the pickup mechanism assembly descended. (The slider position to the left side.)

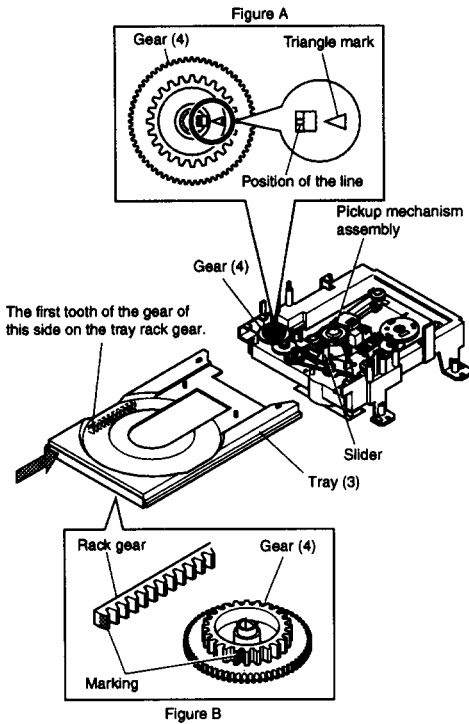

Fig. 1-5

1-5. PC Board Replacement

1. Before removing the main PC board, be sure to short-circuit the laser diode output land. After replacing, open the land as it was after inserting the flexible cables.
2. Remove six flexible cables and remove one connector.
3. Remove four screws.
4. Release two claws and remove the main PC board.

Mechanism Parts

2-1. Loading Belt

1. Remove the gear(1) by releasing the claw.
2. Remove the gear(2).
3. Remove the gear(3) and the loading belt(4).
4. Replace the loading belt(4) with a new one.
5. when mounting, perform the reverse order of the removal.

Note:

When mounting the loading belt(4), twisting and attaching of a grease, etc. not allowed.

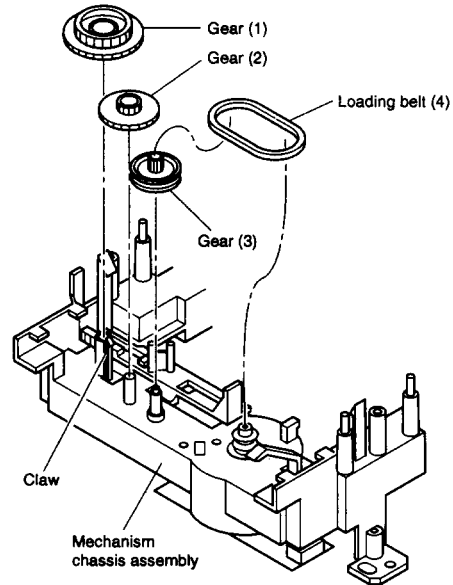

Fig. 2-1

2-2. Loading Motor

1. Remove the loading belt.
2. Remove two screw(1) and two claws. Then remove the loading motor(2)(with the loading motor PC board(3) attached).
3. Desolder the terminal section of the loading motor(2)
4. Replace the loading motor(2) with a new one.
5. When mounting, perform the reverse order of the removal.

Note:

When replacing the loading motor, meet the polarity phase of the terminals.

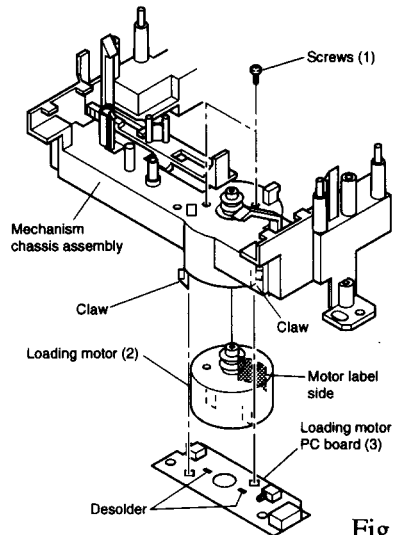

Fig. 2-2

2-3. Sub Chassis (with a pickup mechanism)

1. Turn the mechanism chassis assembly (1) upside down.
2. Remove one screw (2) and release the boss "A" from the claw. Then remove the sub chassis (3) (with the pickup mechanism) by sliding in the arrow direction.
3. when mounting, perform the reverse order of the removal.

Note:

- When mounting the sub chassis (3) (with the pickup mechanism), first, insert the boss "C" along the groove of the cam slider up/down cam (4) and next, the boss "B" and "A".
- The boss "A" and "B" may be used with washers. (one or two washers are used to prevent from the thrust rattling. In some cases, no washer is used.) When the washer(s) is used, be sure to assemble as it was without losing.

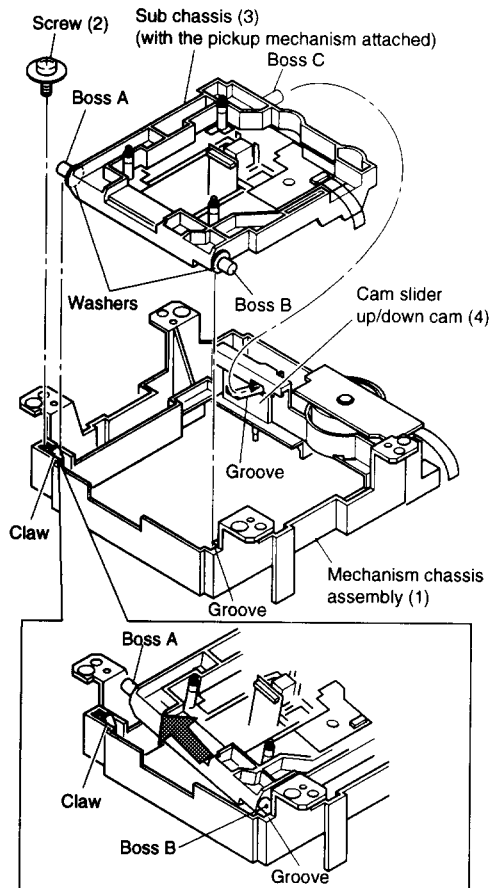

Fig. 2-3

2-4. Pickup Mechanism Assembly

<Removal>

1. Remove four screws (1) and four washers (2) and then remove the pickup mechanism assembly (3).

<Mounting>

1. Replace the pickup mechanism assembly (3) with a new one.
2. when mounting perform the reverse order of the removal.

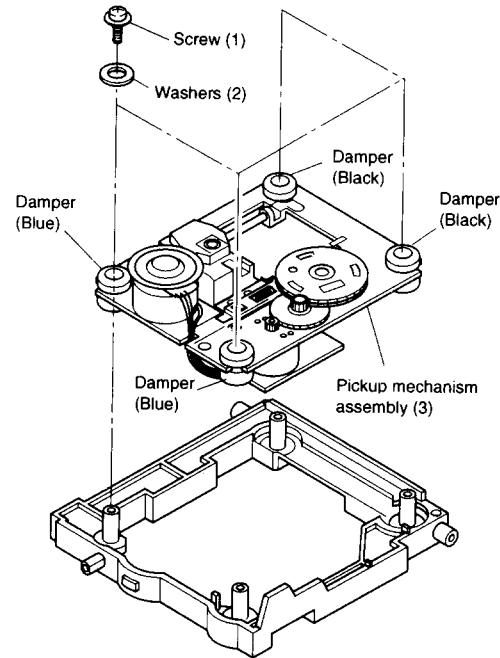

Fig. 2-4-1

Note:

- The damper's color differs when used for the front side and the rear.
- When mounting the pickup mechanism assembly (2) with the screws (1), push the pickup mechanism assembly (2) downward being caught and tighten the screws (1) after placing the washer with the damper bent.

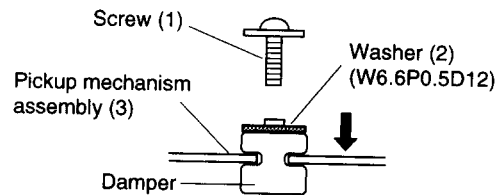

Fig. 2-4-2

2-5. Gear B Assembly, Gear A and Rack Gear Assembly

<Removal>

1. Release one claw and remove the gear B assembly (1).
2. Remove the gear A (2).
3. Remove one screw (3) and remove the rack gear assembly (4).

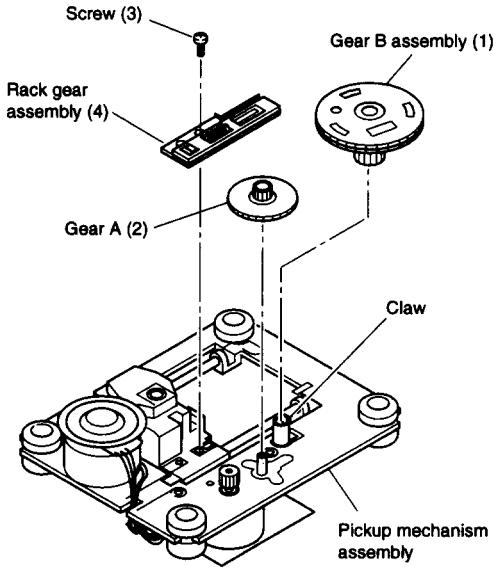

Fig. 2-5-1

<Mounting>

1. When mounting, perform the reverse order of the removal.
2. Mount the gear B assembly (1) by pushing the pickup head (5) to the disc motor side (arrow A direction) and shifting the upper gear of the rack gear assembly (4) in the arrow B direction.
3. Fit the positioning holes on the upper gear and lower gear of the gear B assembly (1) and mount on the pickup mechanism assembly with the phase matched. At this time, note that the phase of the gear B assembly (1) and the gear A (2) show's the status in the Fig. 2-5-3.

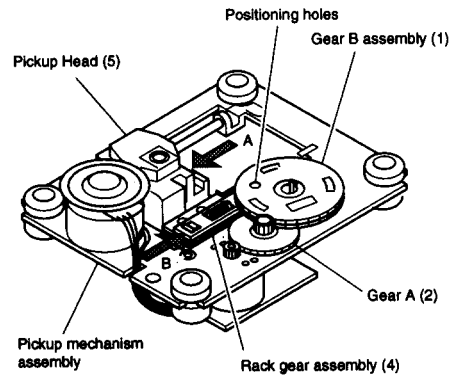

Fig. 2-5-2

Note:

- Mount the gear B assembly (1) and the gear a (2) with their gear teeth placed more than on tooth at least inside the shaded portion.

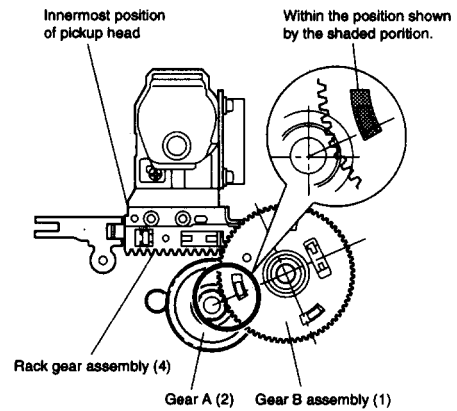

Fig. 2-5-3

2-6. Feed Motor

<Removal>

1. Remove the gear B assembly (1) and the gear A (2).
2. Remove two screws (1) and remove the feed motor (2) (with the feed motor PC board (3) attached.)
3. Desolder the terminals of the feed motor (2) and remove the feed motor PC board (3).

<Mounting>

1. Tighten the feed motor (2) on the pickup mechanism assembly with two screws (1).
2. Insert the feed motor PC board (3) with the positioning pin on the chassis matched and solder the terminals.
3. Perform the reverse order of the removal.

Note:

- After mounting, put the lead wires through the notch of the pickup mechanism assembly.
- When replacing the loading motor, meet the polarity phase of the terminals.

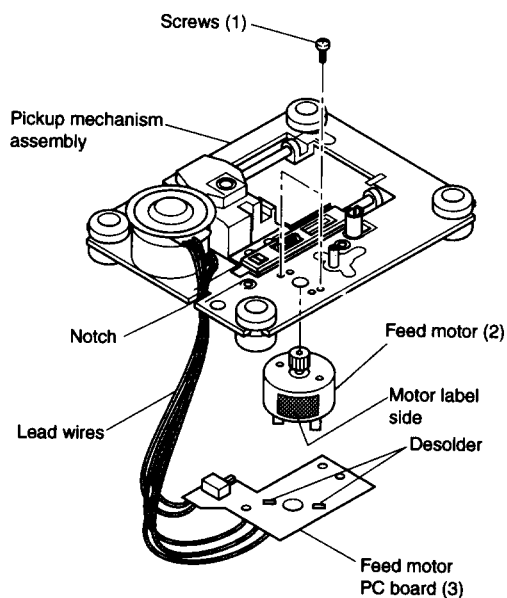

Fig. 2-6

3. TROUBLESHOOTING

3-1. Servo System

(1) Initial Operation after Power ON

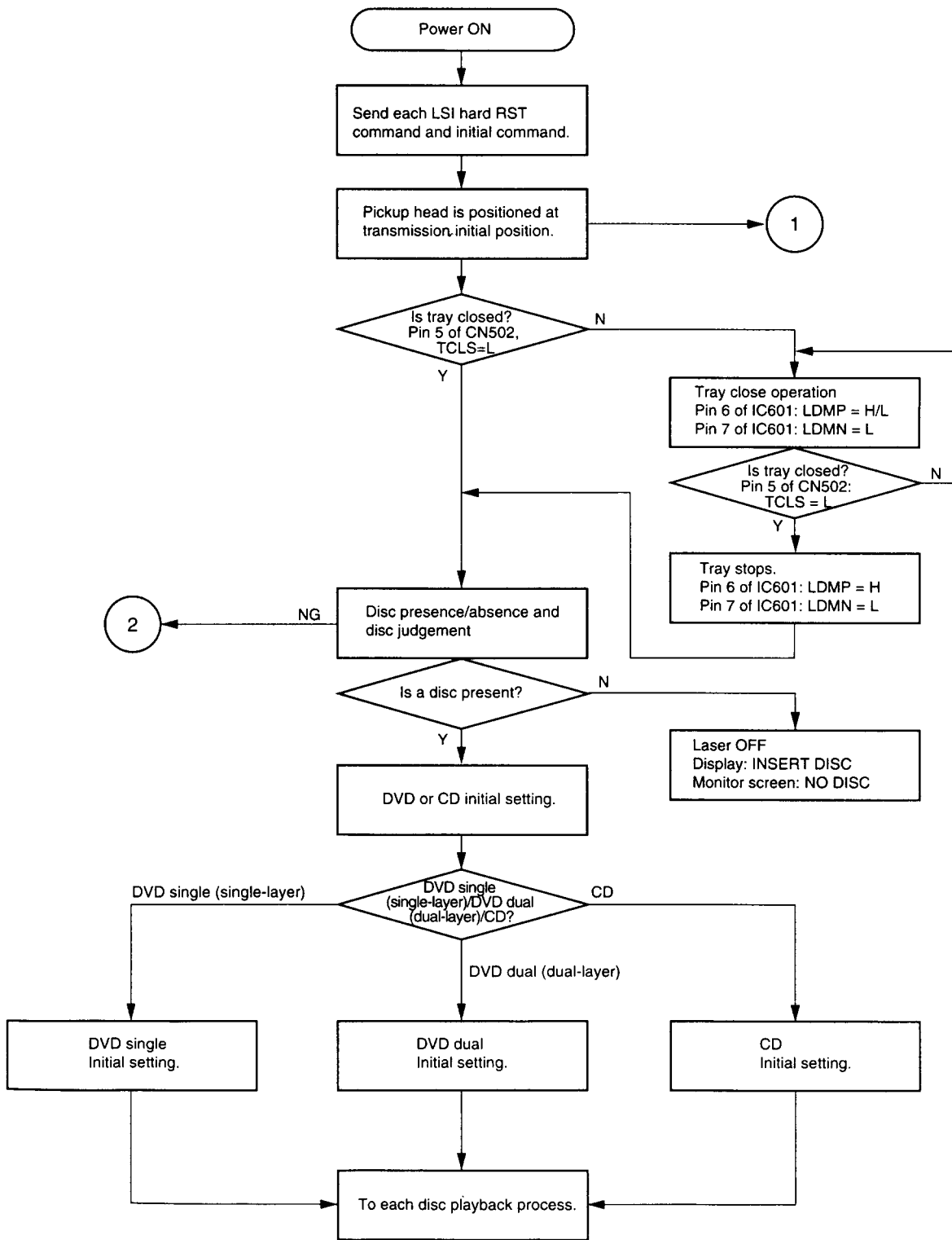

Fig.3-1

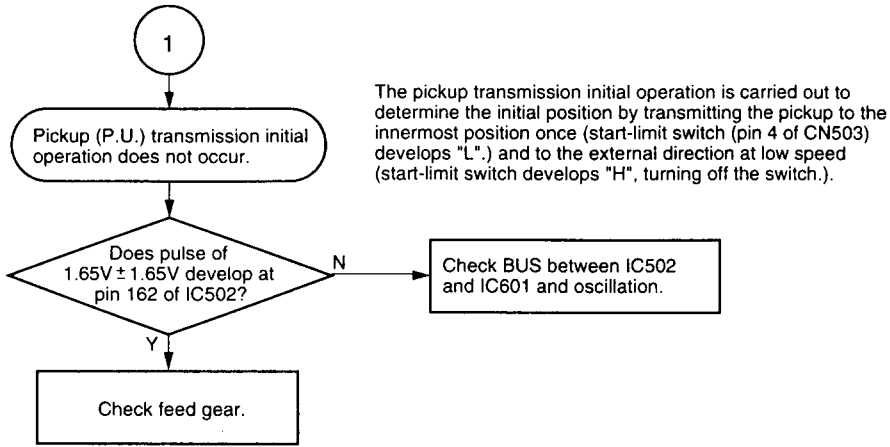

Fig. 3-2

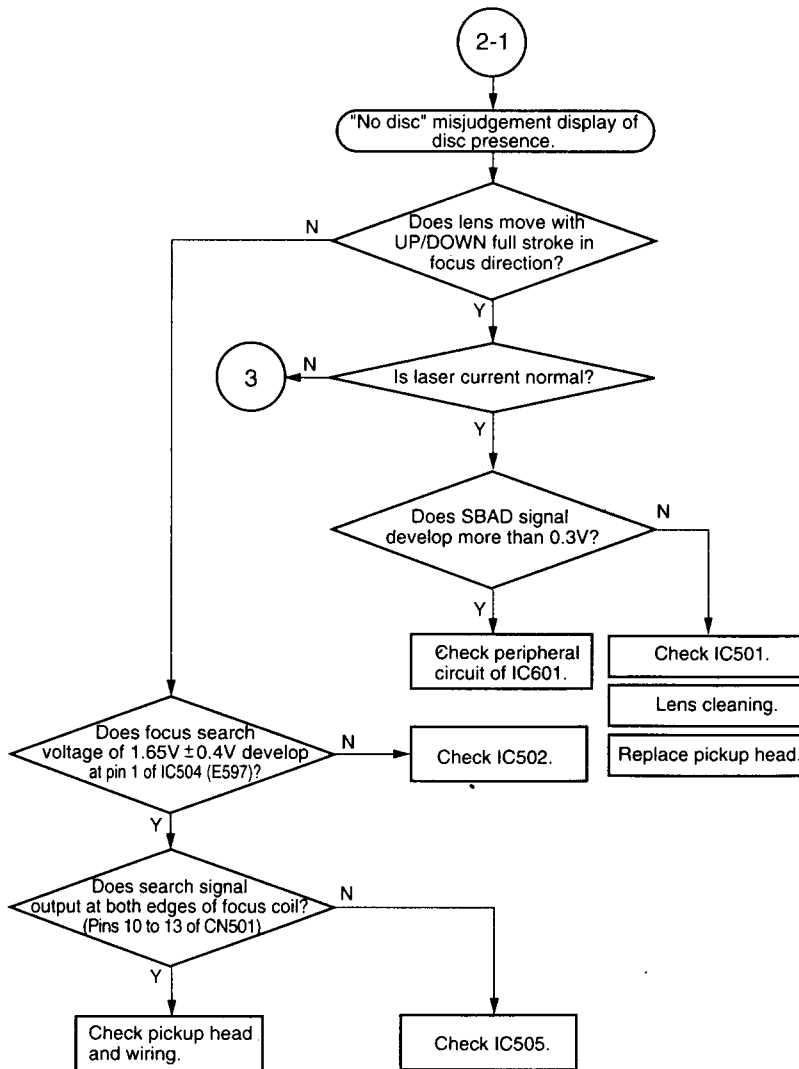

Fig. 3-3

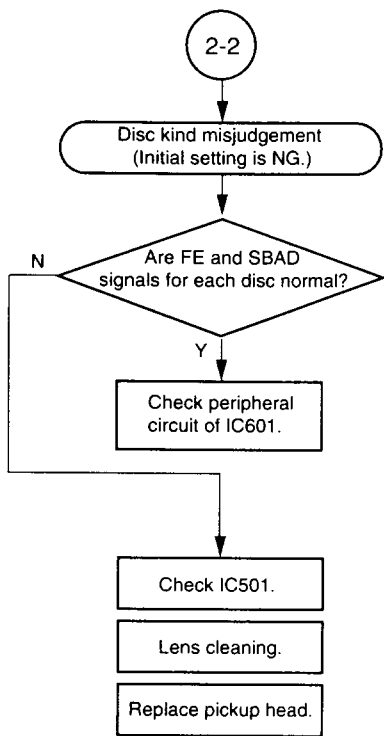

Fig. 3-4

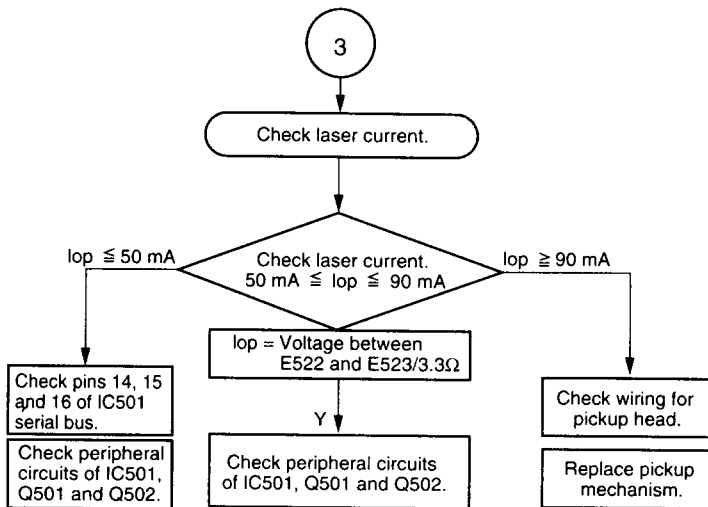

Fig. 3-5

DVD single (single-layer) disc
detection waveform

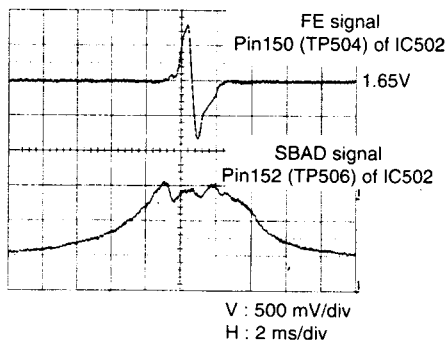

Fig. 3-6

DVD dual (dual-layer) disc
detection waveform

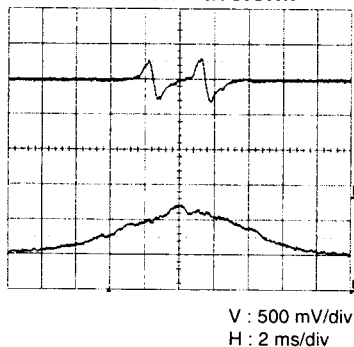

Fig. 3-7

CD disc
detection waveform

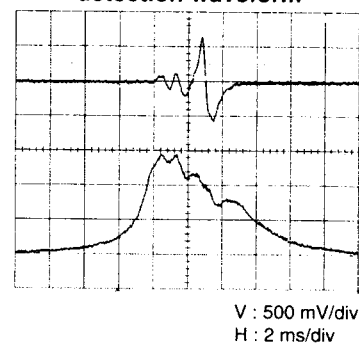

Fig. 3-8

(2) Picture appears (PLAY)

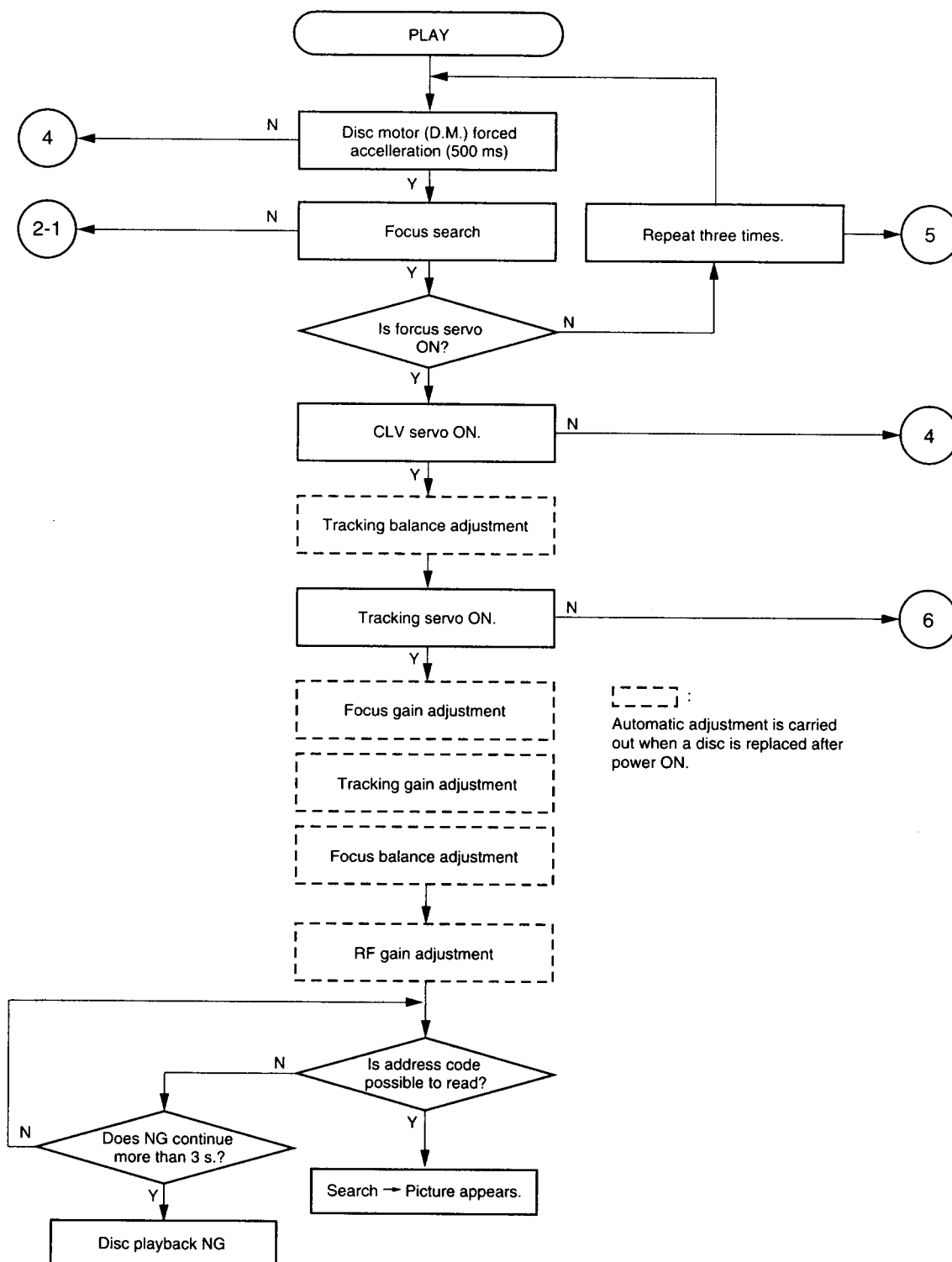

Fig. 3-9

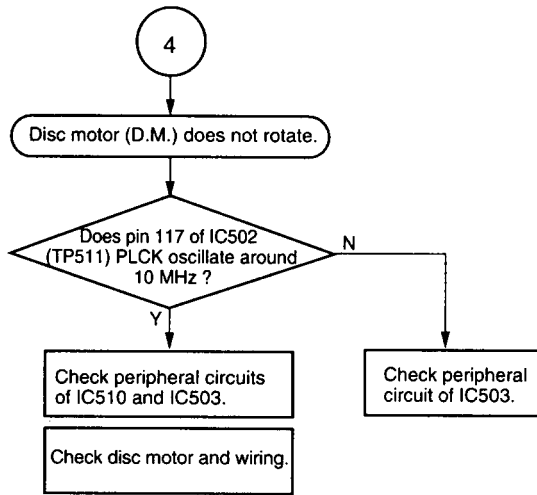

Fig. 3-10

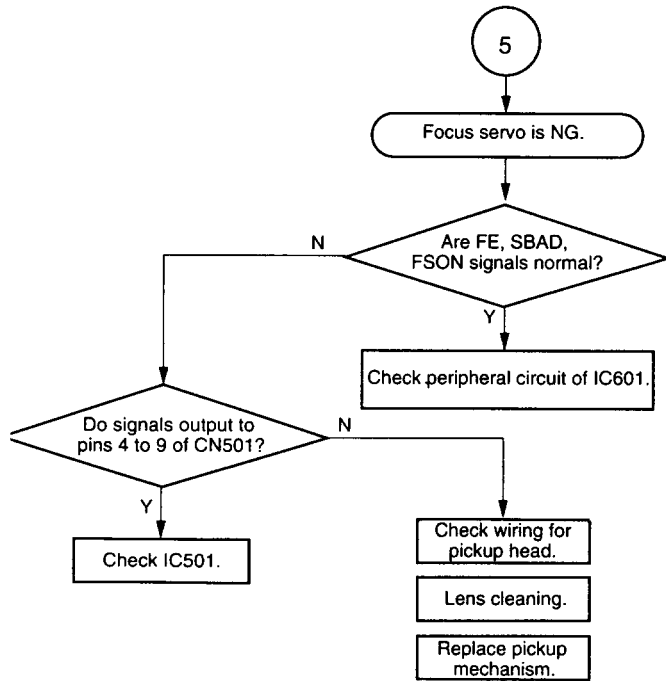

Fig. 3-11

Focus servo ON signal waveform

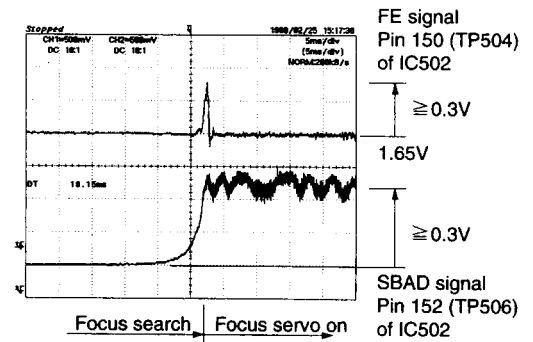

Fig.3-12

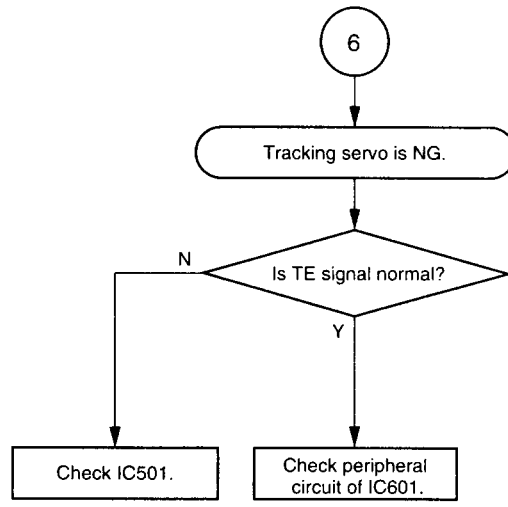
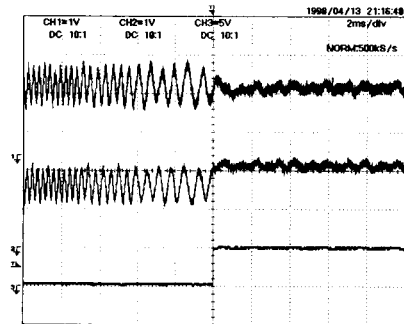

Fig. 3-13

Signal waveform at tracking servo ON (CD)



TE signal
Pin 151 (TP503) of IC502
1.65V

RFRP signal
Pin 153 (TP501) of IC502

Search ON (SRCH)
Pin 38 (TP508) of IC502

Filter: OFF
Smoothing: OFF
BW: FULL

Offset: CH1: 0.00V
CH2: 0.00V
CH3: -0.10V
CH4: 5.20V

Record Length: Main: 10K
Zoom: 2.5K

Trigger: Mode: NORMAL
Type: EDGE CH3
Delay: 0.0ns
Hold Off: MINIMUM

ON search | Tracking servo on

Fig. 3-14

Signal waveform at tracking servo ON (DVD)

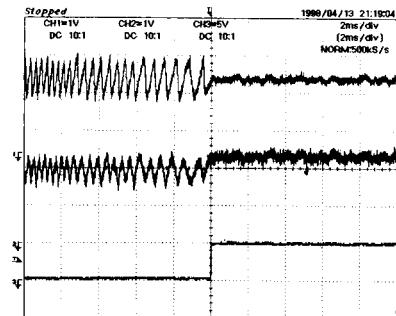

Filter: OFF
Smoothing: OFF
BW: FULL

Offset: CH1: 0.00V
CH2: 0.00V
CH3: -0.10V
CH4: 5.20V

Record Length: Main: 10K
Zoom: 2.5K

Trigger: Mode: NORMAL
Type: EDGE CH3
Delay: 0.0ns
Hold Off: MINIMUM

Fig.3-15

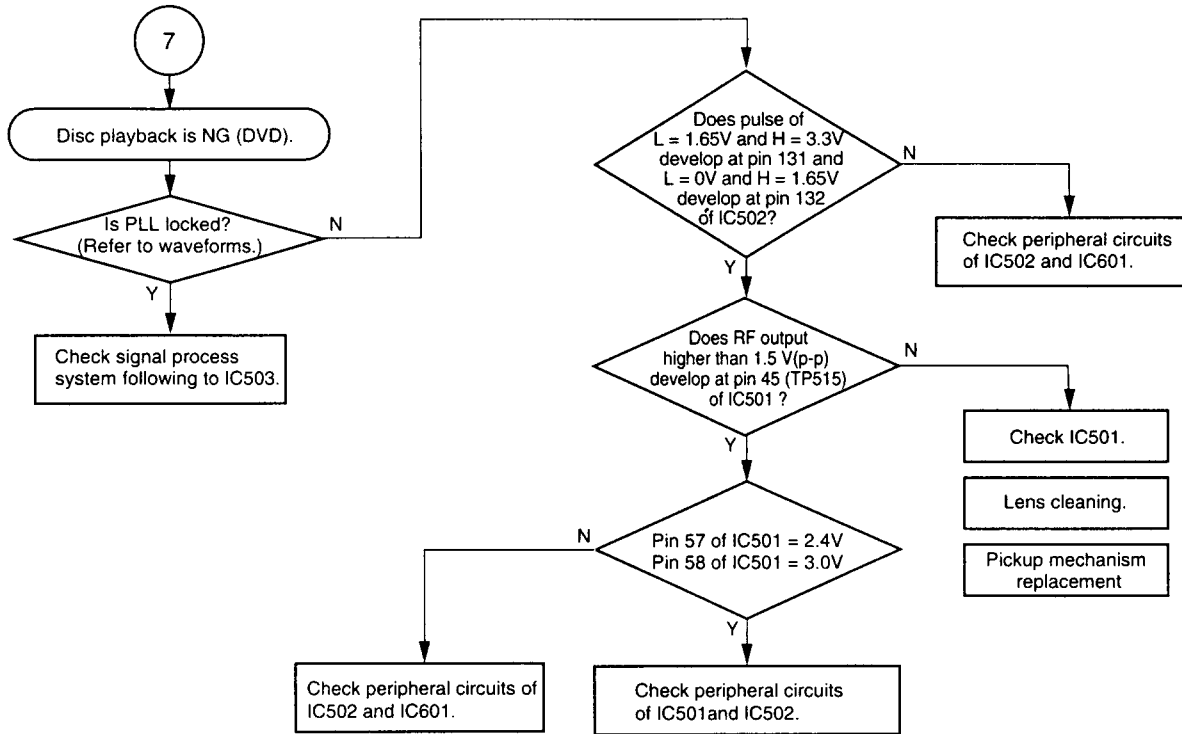

Fig. 3-16

PLL works as a servo loop to generate a clock signal for reading RF signal binary data. With the PLL locked, the eye pattern is identified clearly when triggered with the read clock PLCK.

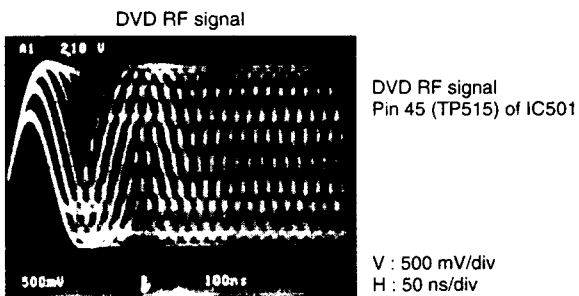

Fig. 3-17

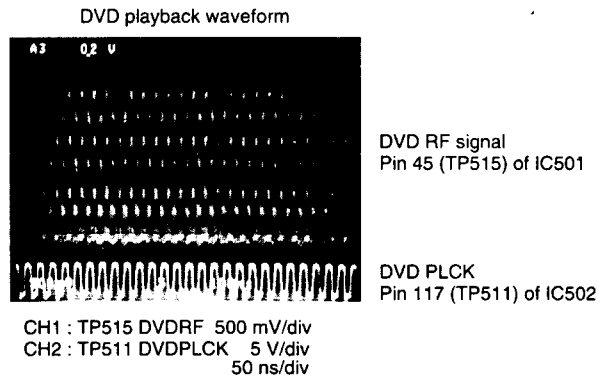

Fig. 3-19

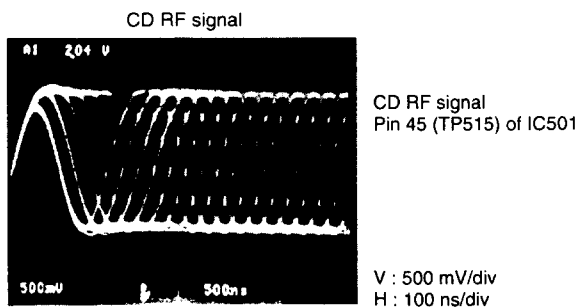

Fig.3-18

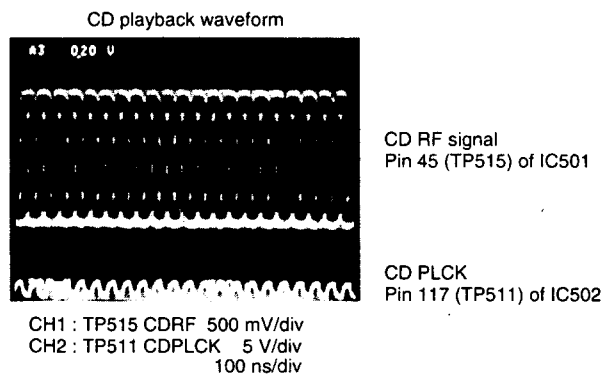

Fig. 3-20

(3) Location Diagram of Servo Test Point

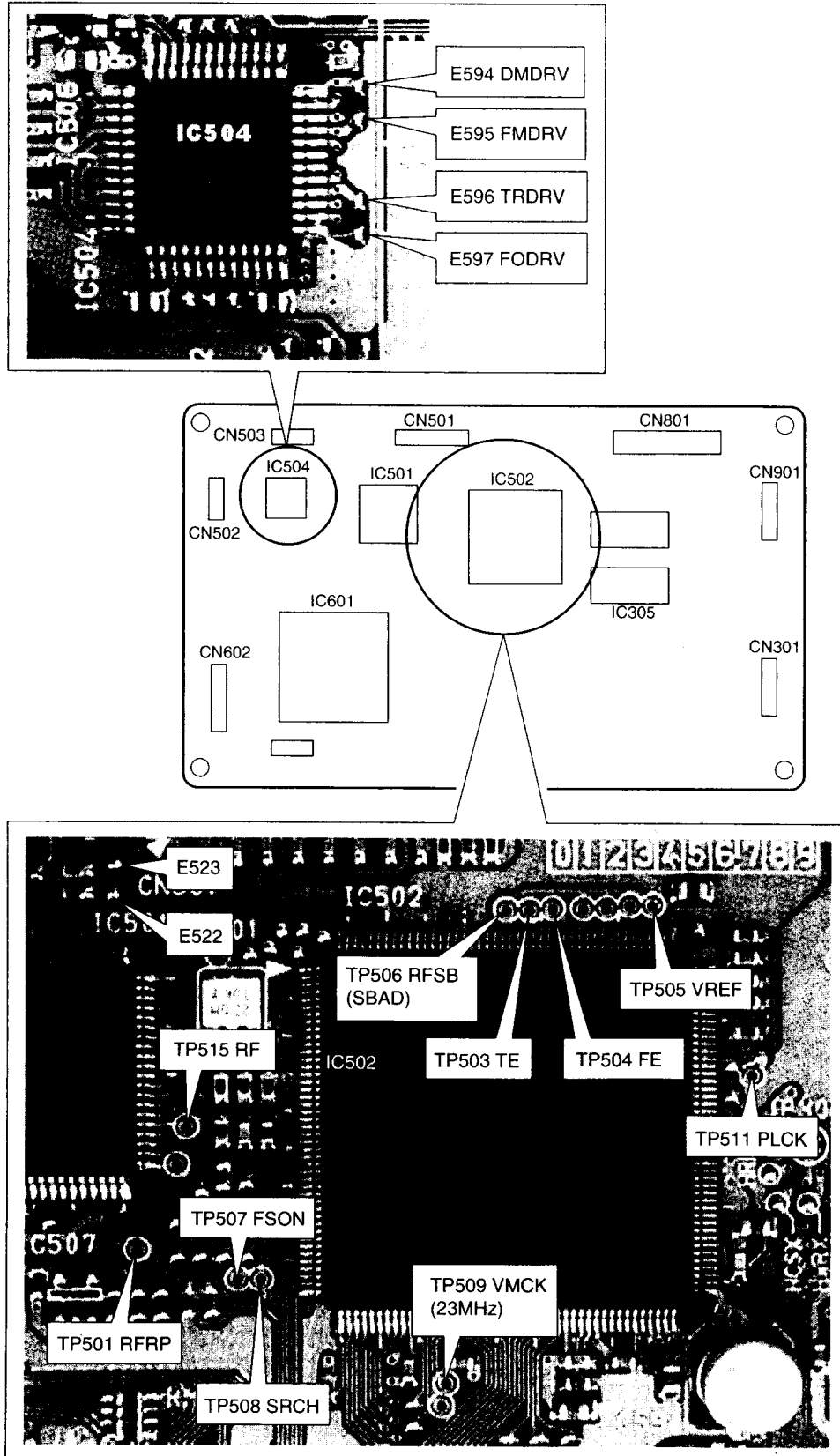
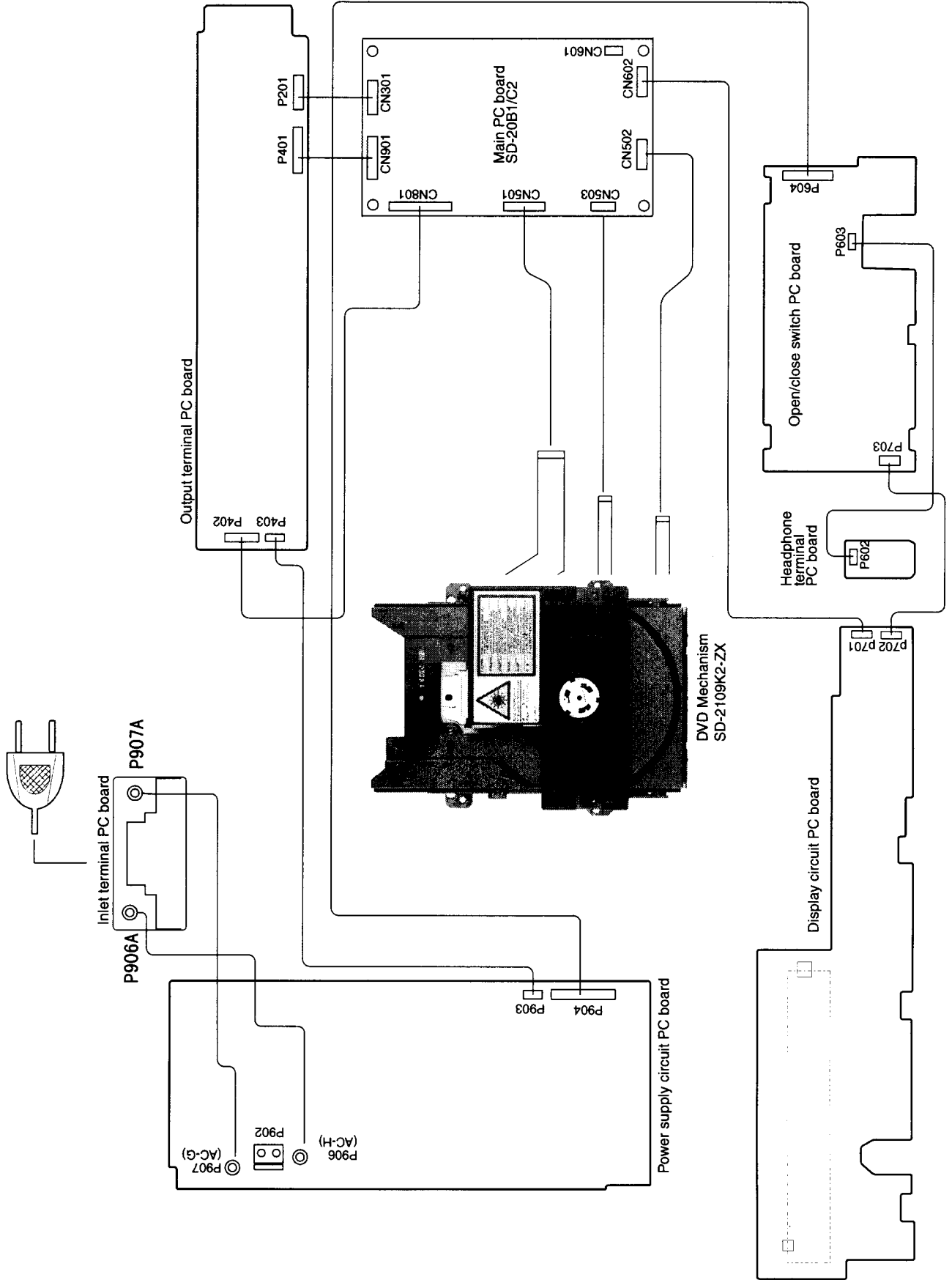
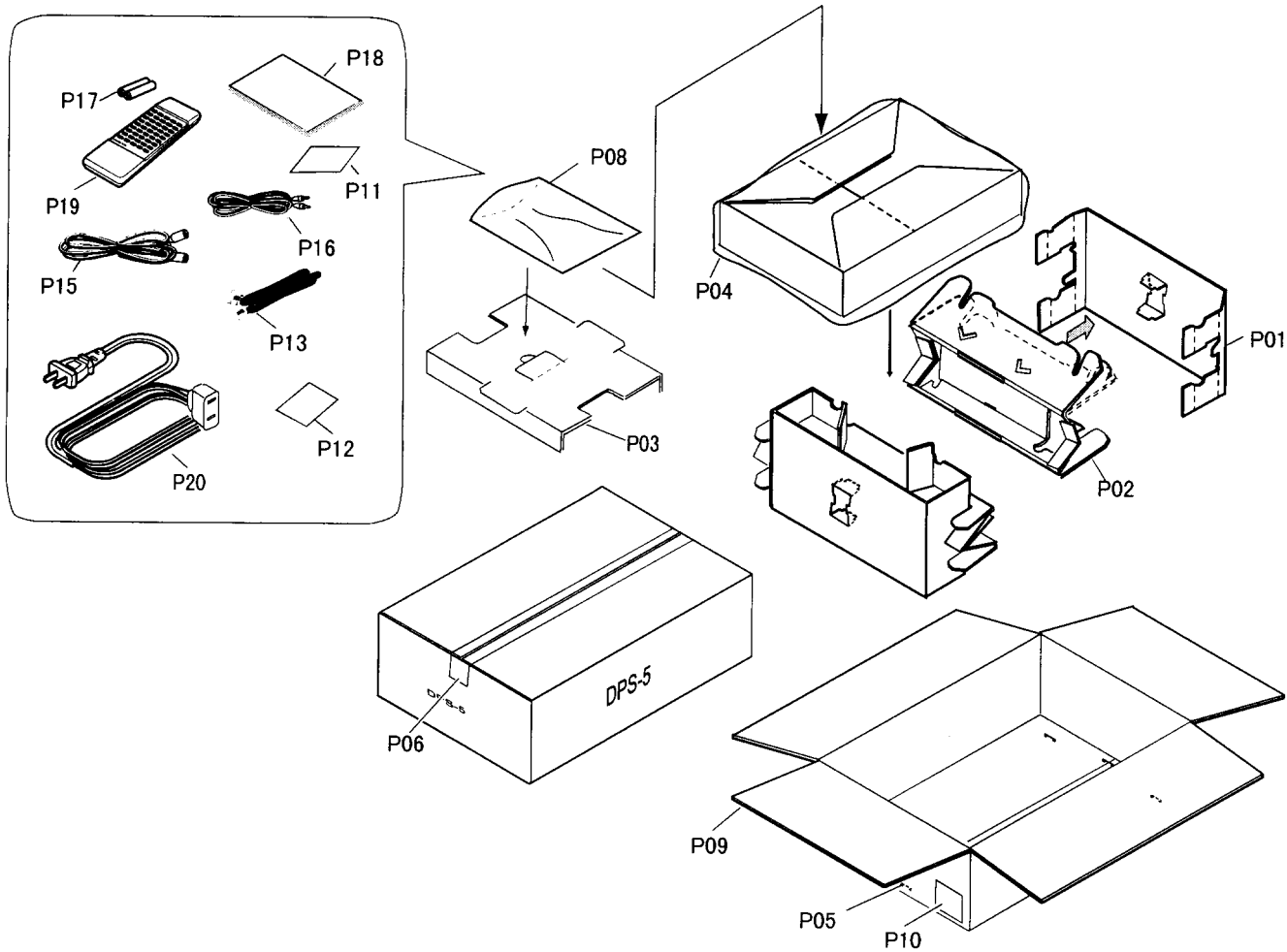

Fig. 3-21

WIRING DIAGRAM



PACKING VIEW



PARTS LIST

REF. No.	PARTS No.	DESCRIPTION
P01	29091892A	Pad
P02	29091893	Pad(S)
P03	29095872	Sheet, ACCE
P04	29095847	Sheet
P05	282321	Staple
P06	29110141	PP tape
P08	29100097-1A	350*250, Polybag
P09	29053494	Carton box
P10	29362510	Label UPC
P11	29365080A	Warranty card
P12	29095865	Sheet, (INTEGRA)
P13	2010359 or 2010359TAIDA	RCA-3P(YWR) or RCA-3P(YWR), Pin cord
P15	2010360	TPX3000, Cord ass'y
P16	2010200	Remote controller cord
P17	3010054	Battery, UM-3
P18	29342791A	Instruction manual E
P19	24141417A	Remote controller
P20	253295KAW	AC cord

ONKYO CORPORATION

Sales & Product Planning Div. : 2-1, Nisshin-cho, Neyagawa-shi, OSAKA 572-8540, JAPAN
Tel: 0720-31-8111 Fax: 0720-33-5222

ONKYO U.S.A. CORPORATION

200 Williams Drive, Ramsey, N.J. 07446, U.S.A.
Tel: 201-825-7950 Fax : 201-825-8150 E-mail: onkyo@onkyousa.com

