

# Integra SERVICE MANUAL

## DVD PLAYER MODEL DPS-6.5

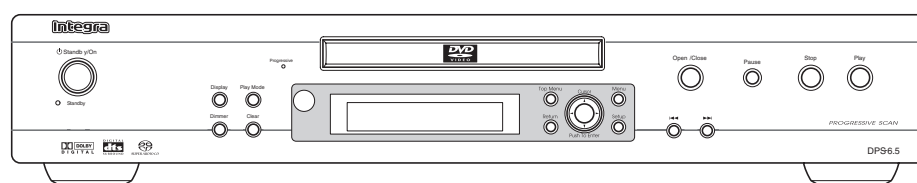

RC-583DV

### Black model

MDD	120V AC, 60Hz
MUA	100-240V AC 50/60Hz

### SAFETY-RELATED COMPONENT WARNING!!

COMPONENTS IDENTIFIED BY MARK  ON THE SCHEMATIC DIAGRAM AND IN THE PARTS LIST ARE CRITICAL FOR RISK OF FIRE AND ELECTRIC SHOCK. REPLACE THESE COMPONENTS WITH ONKYO PARTS WHOSE PART NUMBERS APPEAR AS SHOWN IN THIS MANUAL.

MAKE LEAKAGE-CURRENT OR RESISTANCE MEASUREMENTS TO DETERMINE THAT EXPOSED PARTS ARE ACCEPTABLY INSULATED FROM THE SUPPLY CIRCUIT BEFORE RETURNING THE APPLIANCE TO THE CUSTOMER.

# SPECIFICATION

## DPS-6.5

Signal System		North American model: NTSC Australian model: PAL/NTSC
Composite Video Output/Impedance		1.0 V (p-p)/75 $\Omega$ negative sync, RCA
S Video Output/Impedance		Y: 1.0 V (p-p)/75 $\Omega$ negative sync, 4-pin mini DIN C: 0.286 V (p-p)/75 $\Omega$
Component Video Output/Impedance		Y: 1.0 V (p-p)/75 $\Omega$ PB/PR: 0.7 V (p-p)/75 $\Omega$ RCA/ phono
Component Video Frequency Response		5 Hz-50 MHz
Frequency response	DVD Audio	4 Hz-88 kHz (192 kHz)
	DVD Linear Sound	4 Hz-44 kHz (96kHz) 4 Hz-22 kHz (48kHz)
	Audio CD	4 Hz-20 kHz (44.1kHz)
S/N Ratio		106 dB
Audio Dynamic Range		96 dB
THD (Total Harmonic Distortion)		0.003 % (1kHz)
Wow and Flutter		Below threshold of measurability
Audio Output (Digital/Optical)		-22.5 dBm
Audio Output/Impedance (Digital/Coaxial)		0.5 p-p/75 $\Omega$
Audio Output/Impedance (Analog)		2.0 V (rms)/440 $\Omega$

### ■ General

Power Supply	North American model: AC 120 V, 60 Hz Australian model: AC 100-240 V, 50/60 Hz
Power Consumption	11 W
Stand-by Power Consumption	North American model: 0.6 W Australian model: 0.8 W
Dimensions (W x H x D)	435 W x 81 H x 312 D mm (17 1/8 W x 3 3/16 H x 12 5/16 D inches)
Weight	3.5 kg (7.7 lbs)
Operation Condition Temperature/Humidity	5 °C-35 °C (41 F-95 F)/5 %-85%
Disc Compatibility	SACD, DVD-Audio, DVD-video, DVD-R/RW (VR, VIDEO), CD, CD-R/RW, Video CD, SVCD, WMA, MP3, WMA, JPEG Disc that have not been property finalized may only be partially playable or not playable at all

Specifications and features subject to change without notice.

# SERVICE PROCEDURES-1

## PROTECTION OF EYES FROM LASER BEAM DURING SERVICING

This set employs a laser. Therefore, be sure to follow carefully the instructions below when servicing.

**WARNING!!**

**SERVICE WARNING : DO NOT APPROACH THE LASER EXIT WITH THE EYE TOO CLOSELY. IN CASE IT IS NECESSARY TO CONFIRM LASER BEAM EMISSION, BE SURE TO OBSERVE FROM A DISTANCE OF MORE THAN 30cm FROM THE SURFACE OF THE OBJECTIVE LENS ON THE OPTICAL PICKUP BLOCK.**

**Laser Diode Properties**

Wavelength: 650/780nm (DVD/CD)

### WARNING

**WARNING:**

TO REDUCE THE RISK OF FIRE OR ELECTRIC SHOCK, DO NOT EXPOSE THIS APPLIANCE TO RAIN OR MOISTURE.

**CAUTION:**

TO REDUCE THE RISK OF ELECTRIC SHOCK, DO NOT REMOVE COVER (OR BACK). NO USER-SERVICEABLE PARTS INSIDE. REFER SERVICING TO QUALIFIED SERVICE PERSONNEL.



**WARNING**  
RISK OF ELECTRIC SHOCK  
DO NOT OPEN

**AVIS**  
RISQUE DE CHOC ELECTRIQUE  
NE PAS OUVRIR



The lightning flash with arrowhead symbol, within an equilateral triangle, is intended to alert the user to the presence of uninsulated "dangerous voltage" within the product's enclosure that may be of sufficient magnitude to constitute a risk of electric shock to persons.



The exclamation point within an equilateral triangle is intended to alert the user to the presence of important operating and maintenance (servicing) instructions in the literature accompanying the appliance.

### LASER WARNING

This unit contains a semiconductor laser system and is classified as a "CLASS 1 LASER PRODUCT". So, to use this model properly, read this Instruction Manual carefully. In case of any trouble, please contact the store where you purchased the unit. To prevent being exposed to the laser beam, do not try to open the enclosure.

**CAUTION:**

VISIBLE LASER RADIATION WHEN OPEN AND INTERLOCK FAILED OR DEFEATED. DO NOT STARE INTO BEAM.

**CAUTION:**

THIS PRODUCT UTILIZES A LASER. USE OF CONTROLS OR ADJUSTMENTS OR PERFORMANCE OF PROCEDURES OTHER THAN THOSE SPECIFIED HEREIN MAY RESULT IN HAZARDOUS RADIATION EXPOSURE.

The label on the right is applied on the rear panel except for USA and Canadian models.

**"CLASS 1 LASER PRODUCT"**

1. This unit is a CLASS 1 LASER PRODUCT and employs a laser inside the cabinet.
2. To prevent the laser from being exposed, do not remove the cover. Refer servicing to qualified personnel.

### SERVICE PROCEDURE

#### 1. Replacing the fuses

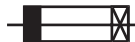

This symbol located near the fuse indicates that the fuse used is show operating type, For continued protection against fire hazard, replace with same type fuse , For fuse rating, refer to the marking adjust to the symbol.

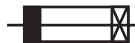

Ce symbole indique que le fusible utilise est e lent. Pour une protection permanente, n'utiliser que des fusibles de meme type. Ce demier est indique la qu le present symbol est appose.

#### LASER BEAM CAUTION LABEL



WAVE LENGTH:650nm  
MAX LASER POWER:0.5mW  
波 長 : 650nm  
最大レーザー出力 : 0.5mW

98764160



REF. NO.	PART NO.	DESCRIPTION
F1	252252 or 252147	1.6A-TL/T-ST2 <MDD>> 1.6A-TSC
F1	252310	2.5A-TH250V Except <MUA>

<MDD> : North American model

<MUA> : Australian model

## SERVICE PROCEDURES-2

### 2. Safety-check out

(Only U.S.A. model)

After correcting the original service problem perform the following safety check before releasing the set to the customer  
Connect the insulating-resistance tester between the plug of power supply cord and terminal GND on the back panel.

Specifications: More than 10M ohm at 500V

## INITIALIZING

Factory-shipped condition.

Connect the power cord to inlet terminal lighting the LED

Press the [STOP] and [STANDBY] same time with NO DISC condition.

Push button "STANDBY".

Pull out the power cord.

## REMOVE THE SOLDER OF LASER DIODE SHORT

When replace the mechanism or DVD main PC board.

Shorting the solder of Shot-circuit land. (2 positions)

Mechanism

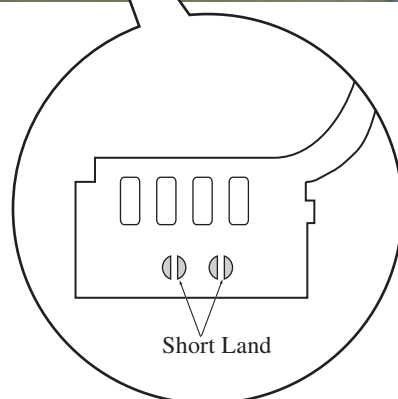
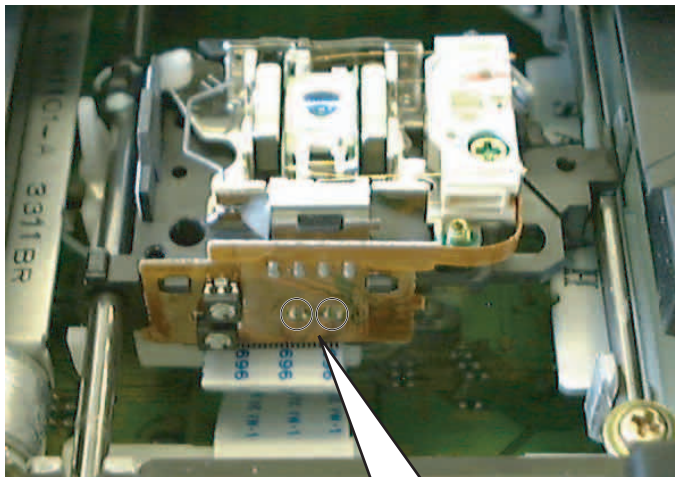

# EXPLODED VIEW

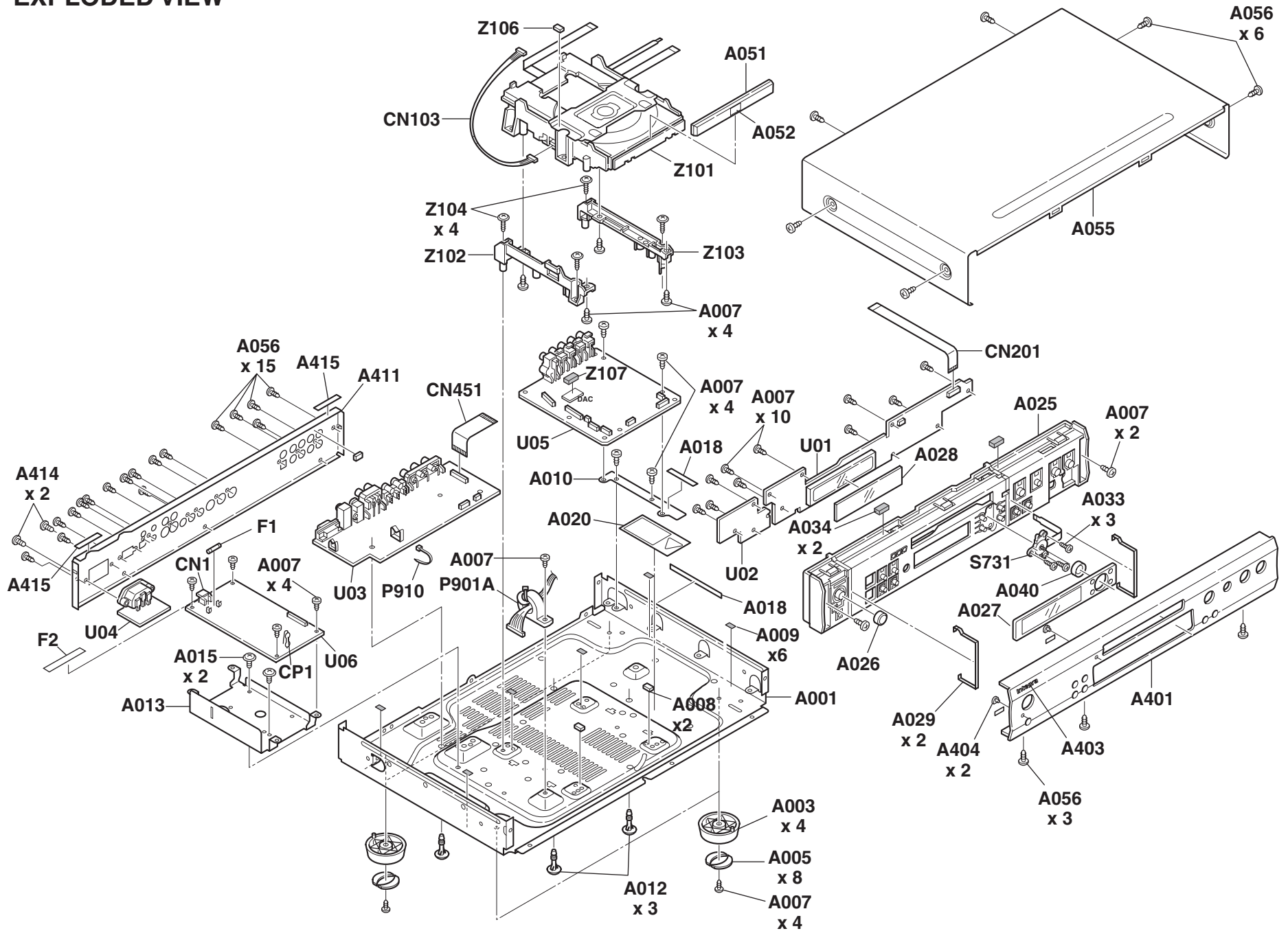



A B C D

# SCHEMATIC DIAGRAMS-1

1

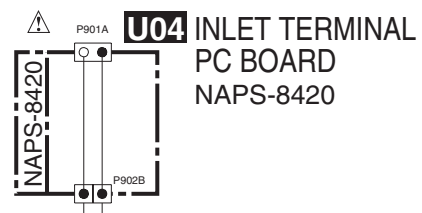

2

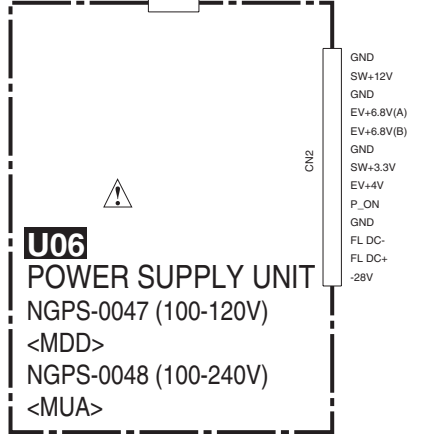

3

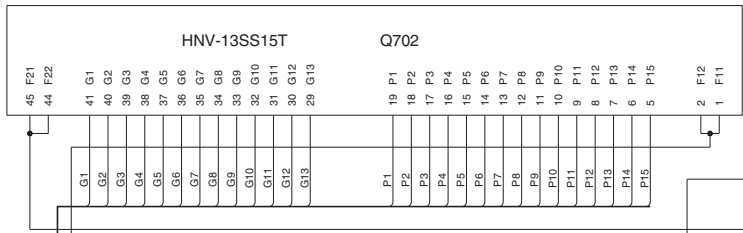

4

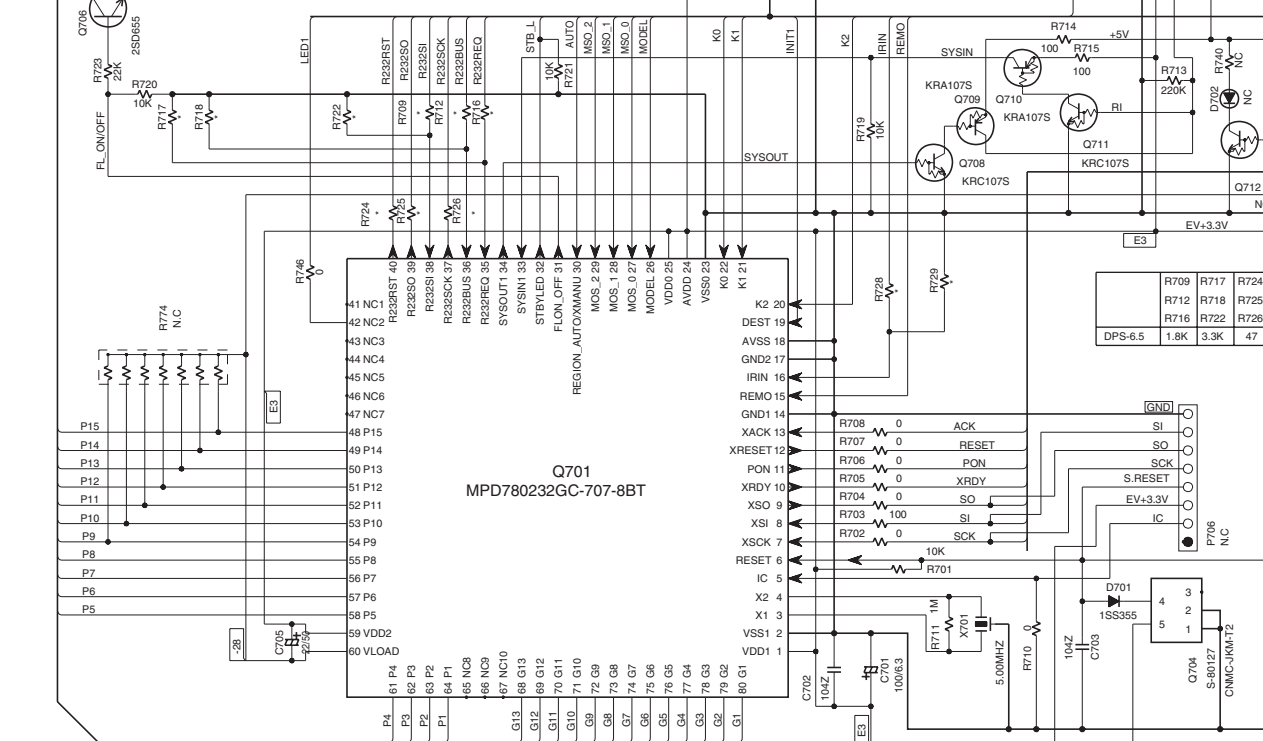

5

**U01** FRONT DISPLAY PC BOARD NADIS-8416

E

F

G

H

C  
GND  
Y  
ASPECT  
V/Y  
BLANK/IP  
R/C/Pr  
GND  
G/Py  
SQUEEZE  
B/Pb  
GND  
AUDIO L  
GND  
AUDIO R  
V+5V  
GND

GND  
SW+12V  
GND  
EV+6.8V(A)  
EV+6.8V(B)  
GND  
SW+3.3V  
EV+4V  
P\_ON  
GND  
FL DC-  
FL DC+  
-28V

**U05 DVD MAIN PC BOARD**  
DB-VPB613

PU SYSTEM

SPINDLE  
MOTER

CARRIAGE MOTOR

LOADING MOTOR

**U02 STANDBY LED PC BOARD**  
NADIS-8417

NADIS-8316

NADIS-8417

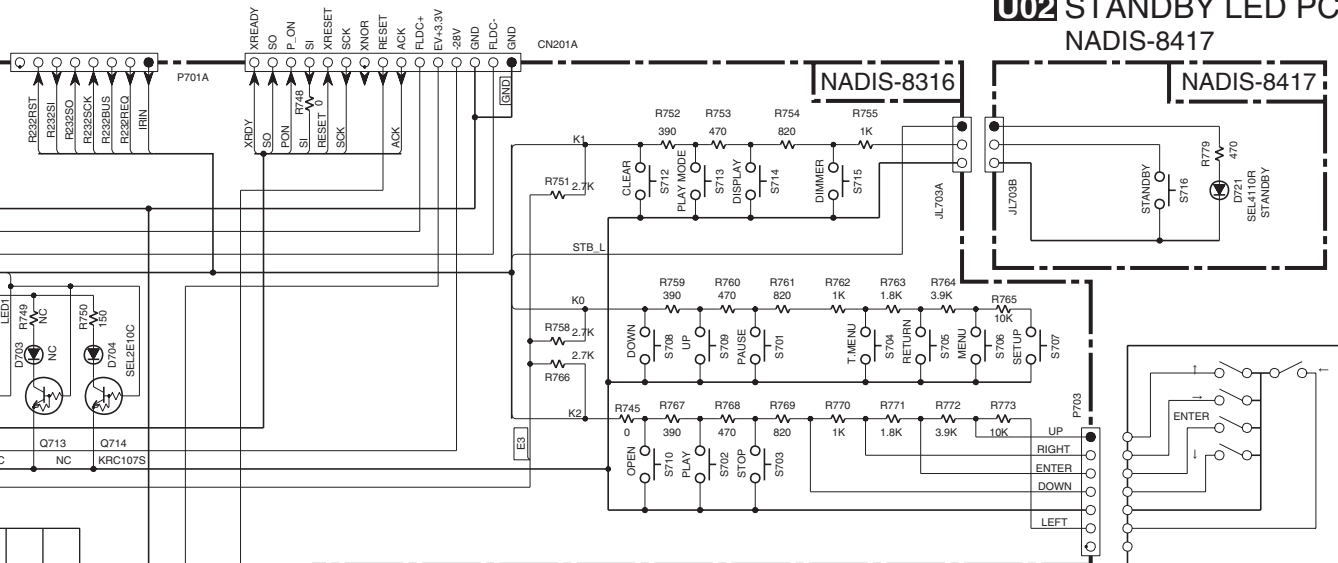

R728	R729
1K	8.2K

R744  
NC

**CAUTION**  
FOR CONTINUED PROTECTION AGAINST FIRE HAZARD, REPLACE ONLY WITH FUSE OF SAME TYPE AND RATING INDICATED.

**ATTENTION**  
AFIN D'ASSURER UNE PROTECTION PERMANENTE CONTRE LES RISQUES D'INCENDIE, REMPLACER UNIQUEMENT PAR UN FUSIBLE DE MEME TYPE ET CALIBRATION COMME INDIQUE.

THIS SYMBOL LOCATED NEAR THE FUSE INDICATES THAT THE FUSE USED IS SLOW OPERATING TYPE FOR CONTINUED PROTECTION AGAINST FIRE HAZARD. REPLACE WITH SAME TYPE FUSE. FOR FUSE RATING REFER TO THE MARKING ADJACENT TO THE SYMBOL.

CE SYMBOLE INDIQUE QUE LE FUSIBLE UTILISE EST LENT. POUR UNE PROTECTION PERMANENTE, UTILISER QUE DES FUSIBLES DE MEME TYPE. CE DERNIER EST INDIQUE LA QU LE PRESENT SYMBOLE EST OPPOSE.

- NOTE**
- THE COMPONENTS IDENTIFIED BY MARK ARE CRITICAL FOR SAFETY FOR SAFETY REPLACE ONLY WITH PART NUMBER SPECIFIED.
  - VOLTAGE (MEASURED WITH VOLTMETER) IS DC VOLTAGE.(NO INPUT SIGNAL)
  - ELECTROLYTIC CAPACITORS () ARE IN uF/WV.
  - ALL CAPACITORS ARE IN pF/50WV UNLESS OTHERWISE NOTED.  
EX) 030> 3pF 330> 33pF 331> 330pF 333> 0.033uF
  - THE THICK LINES ON PC BOARD ARE THE PRINTING SIDE OF THE PARTS.  
EX) PRINTING SIDE
  - CIRCUIT IS SUBJECT TO CHANGE FOR IMPROVEMENT.



# SCHEMATIC DIAGRAMS-2

**U03** AUDIO/VIDEO OUTPUT  
PC BOARD  
NAAR-8419

RS-232C Connector

NAAR-8419

To Fron display board

From Power supply unit CN2

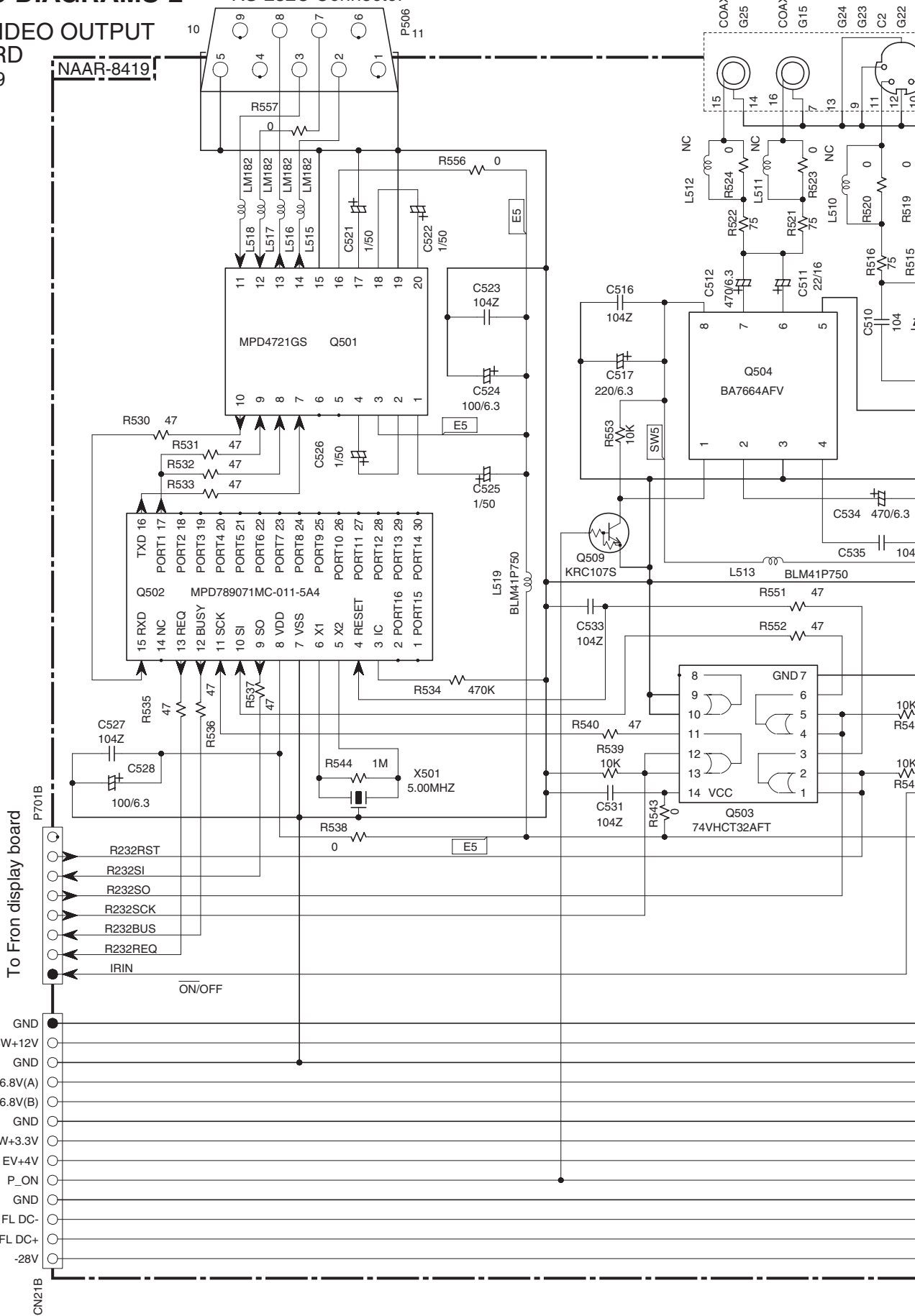

1

2

3

4

5

E

F

G

H

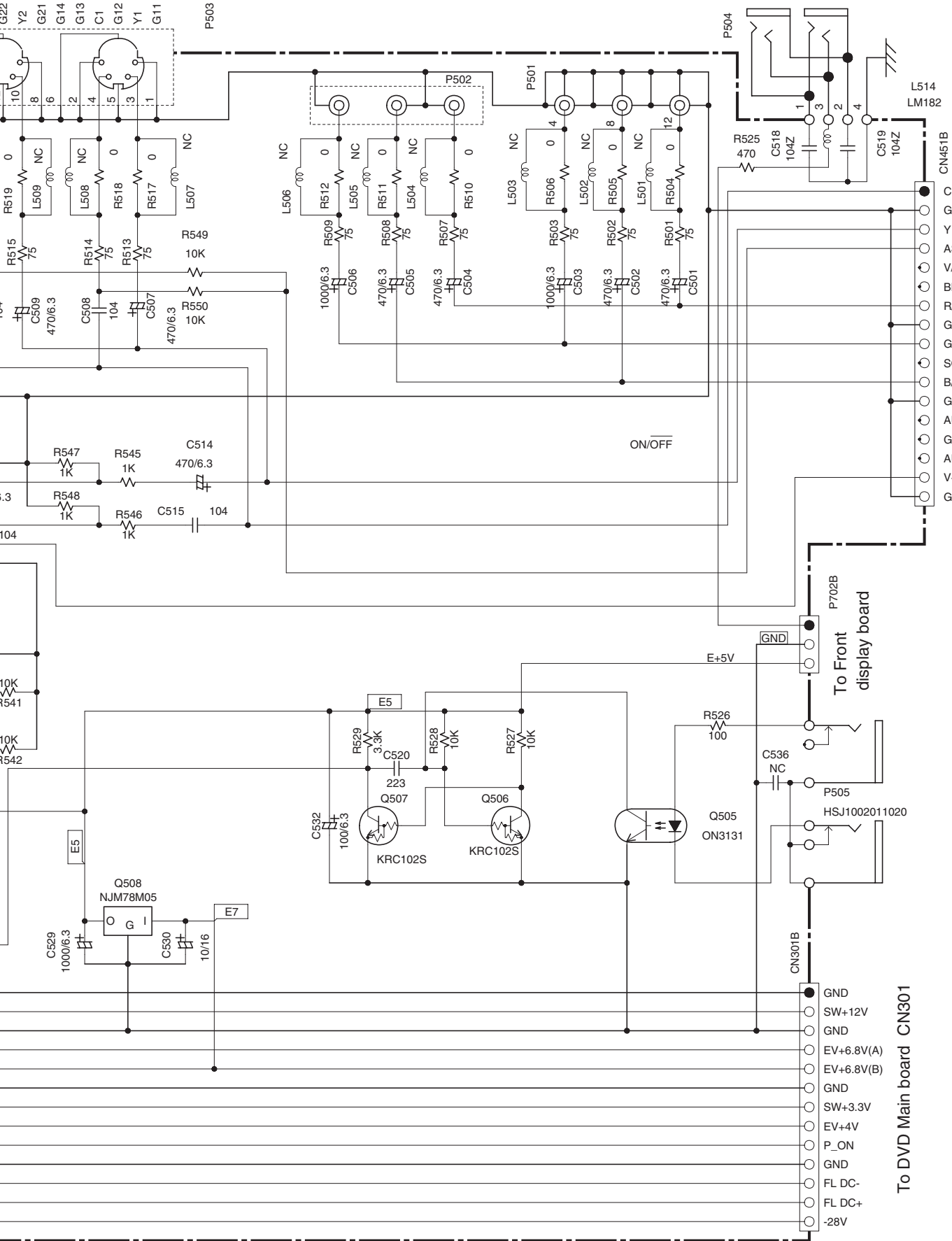

To DVD Main board CN541

To Front display board

To DVD Main board CN301

**SCHEMATIC DIAGRAMS-3**

**B 1/3** U05 DVD MAIN PC BOARD-1  
DB-VP613

1

2

3

4

5

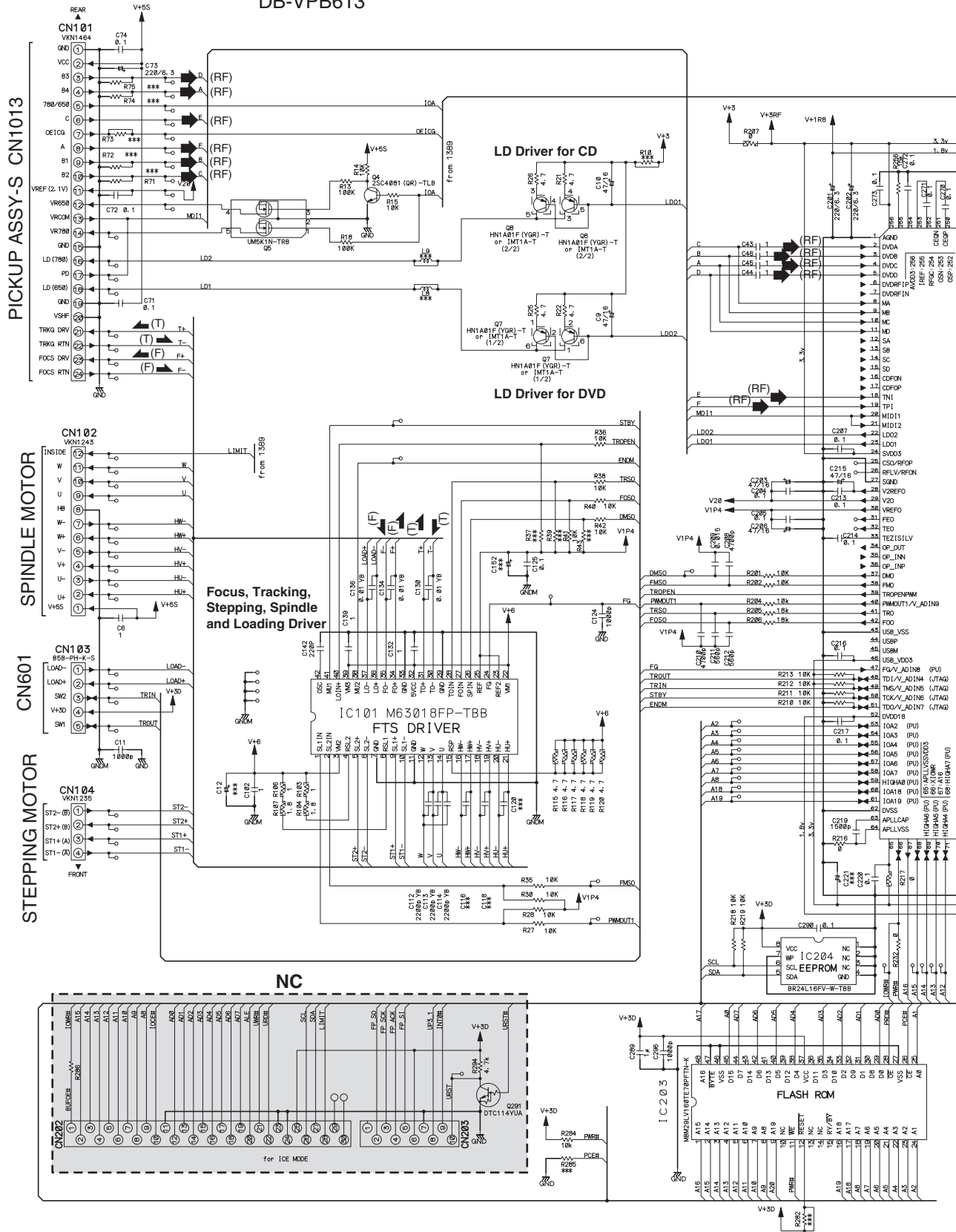

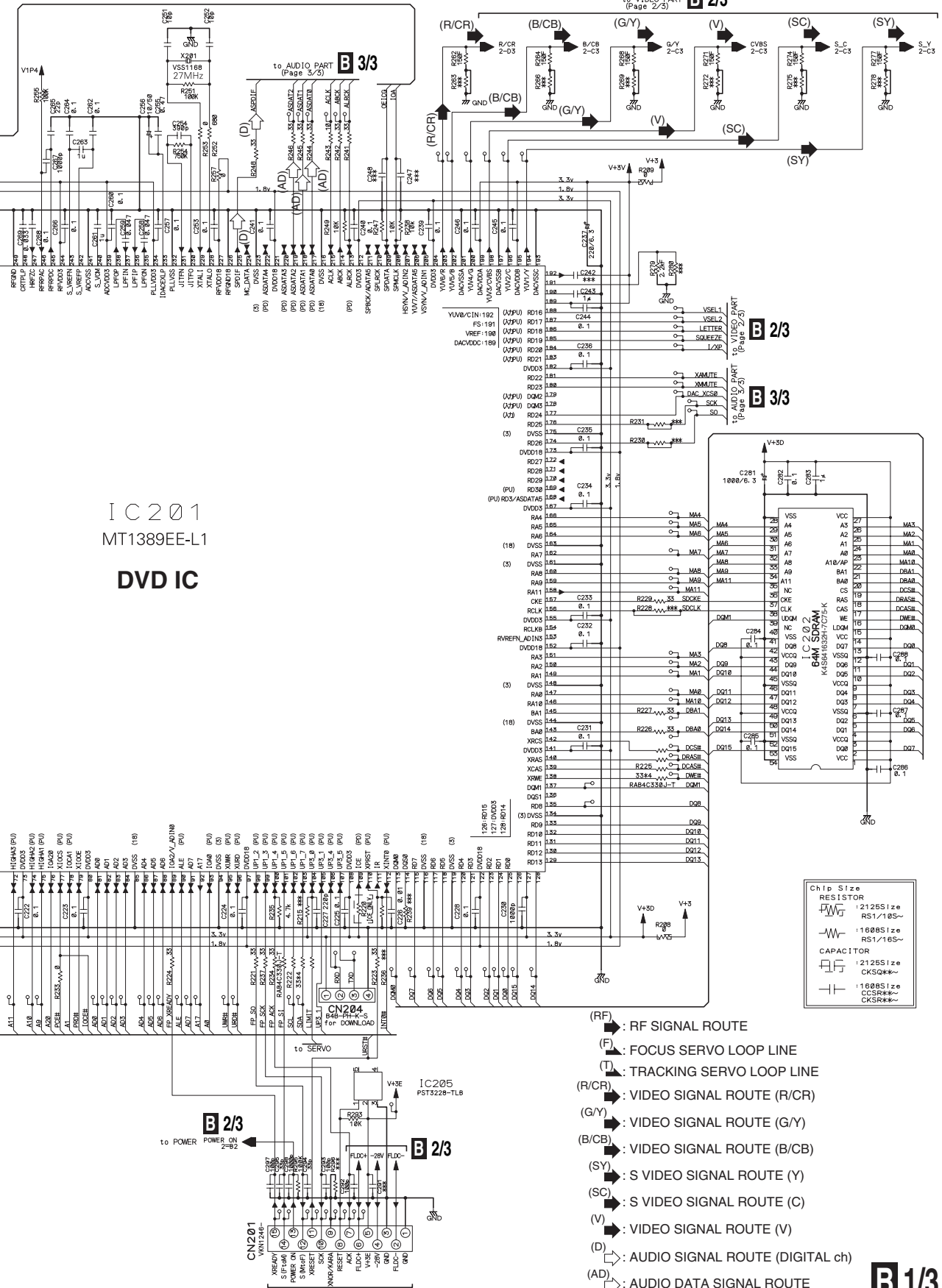

B 2/3

B 2/3

B 2/3

B 2/3

B 3/3

B 1/3

To Front Display PC (NADIS-8316)



E

F

G

H

VIDEO

- (R/CR) : VIDEO SIGNAL ROUTE (R/CR)
- (G/Y) : VIDEO SIGNAL ROUTE (G/Y)
- (B/CB) : VIDEO SIGNAL ROUTE (B/CB)
- (SY) : S VIDEO SIGNAL ROUTE (Y)
- (SC) : S VIDEO SIGNAL ROUTE (C)
- (V) : VIDEO SIGNAL ROUTE (V)

(FL) : AUDIO SIGNAL ROUTE (Front L ch)

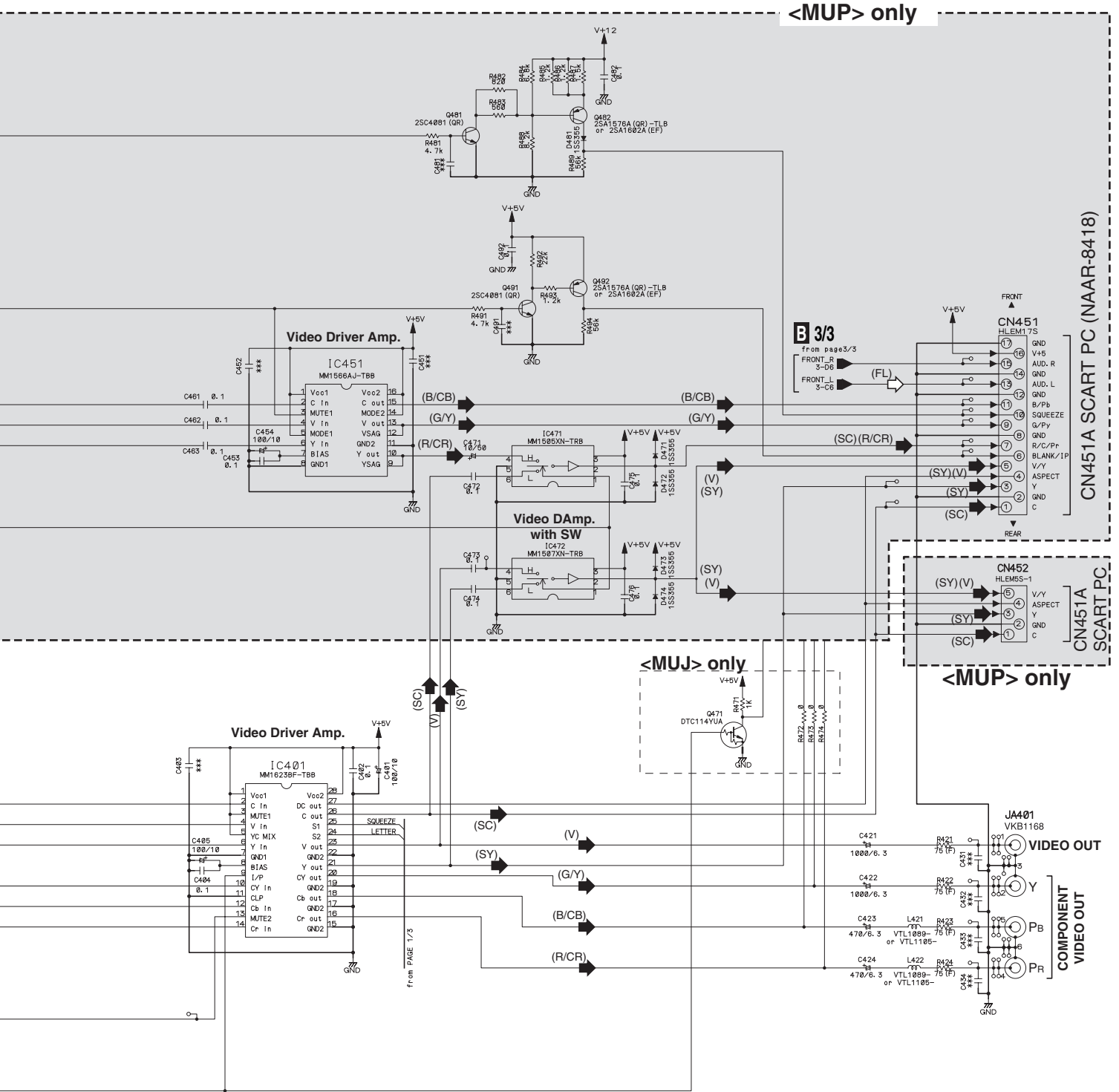

<MUP> only

B 3/3  
From page 3/3  
FRONT\_R 3-D6  
FRONT\_L 3-C6

<MUJ> only

<MUP> only

CN451A SCART PC (NAAR-8418)

CN452 SCART PC

COMPONENT VIDEO OUT



SW for Mute Control

B 1/3

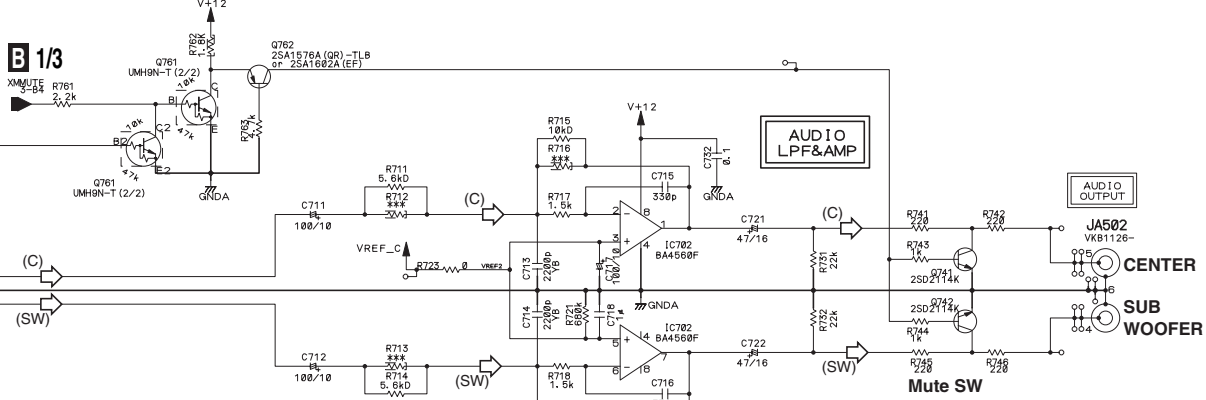

SW for Mute Control

B 1/3

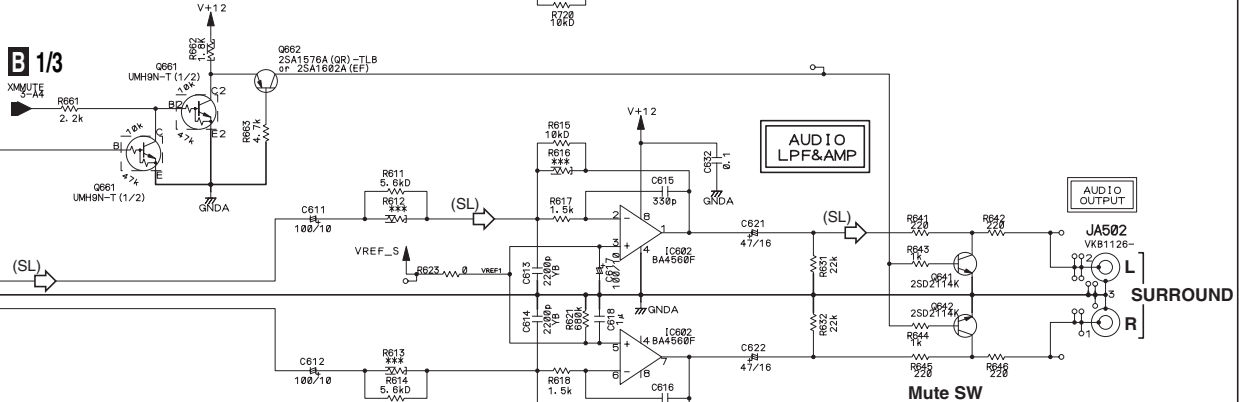

SW for Mute Control

B 1/3

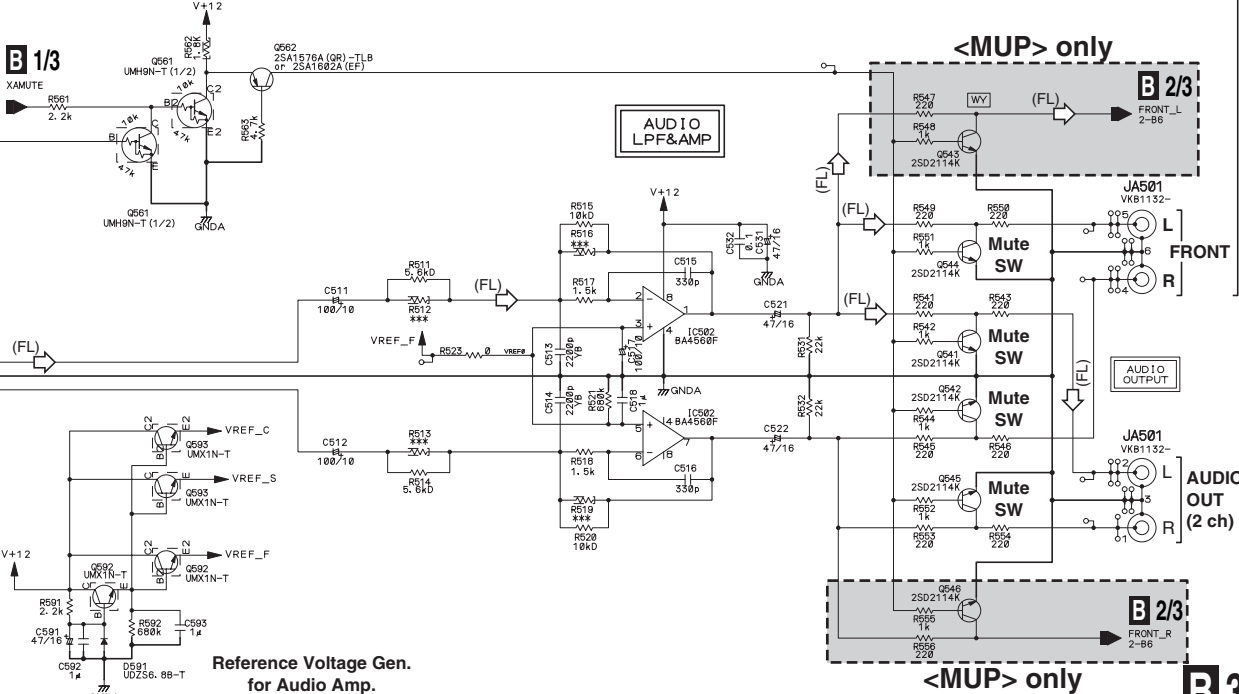

Reference Voltage Gen. for Audio Amp.

AUDIO OUT (5.1 ch)

B 3/3

<MUP> only

<MUP> only



SCHEMATIC DIAGRAMS-6

**U06** POWER SUPPLY UNIT

NGPS-0047 (100-120V) <MDD>  
 NGPS-0048 (100-240V) <MUA>

To NAAR-8418 (AUDIO/ VIDEO BOARD)  
 CN301

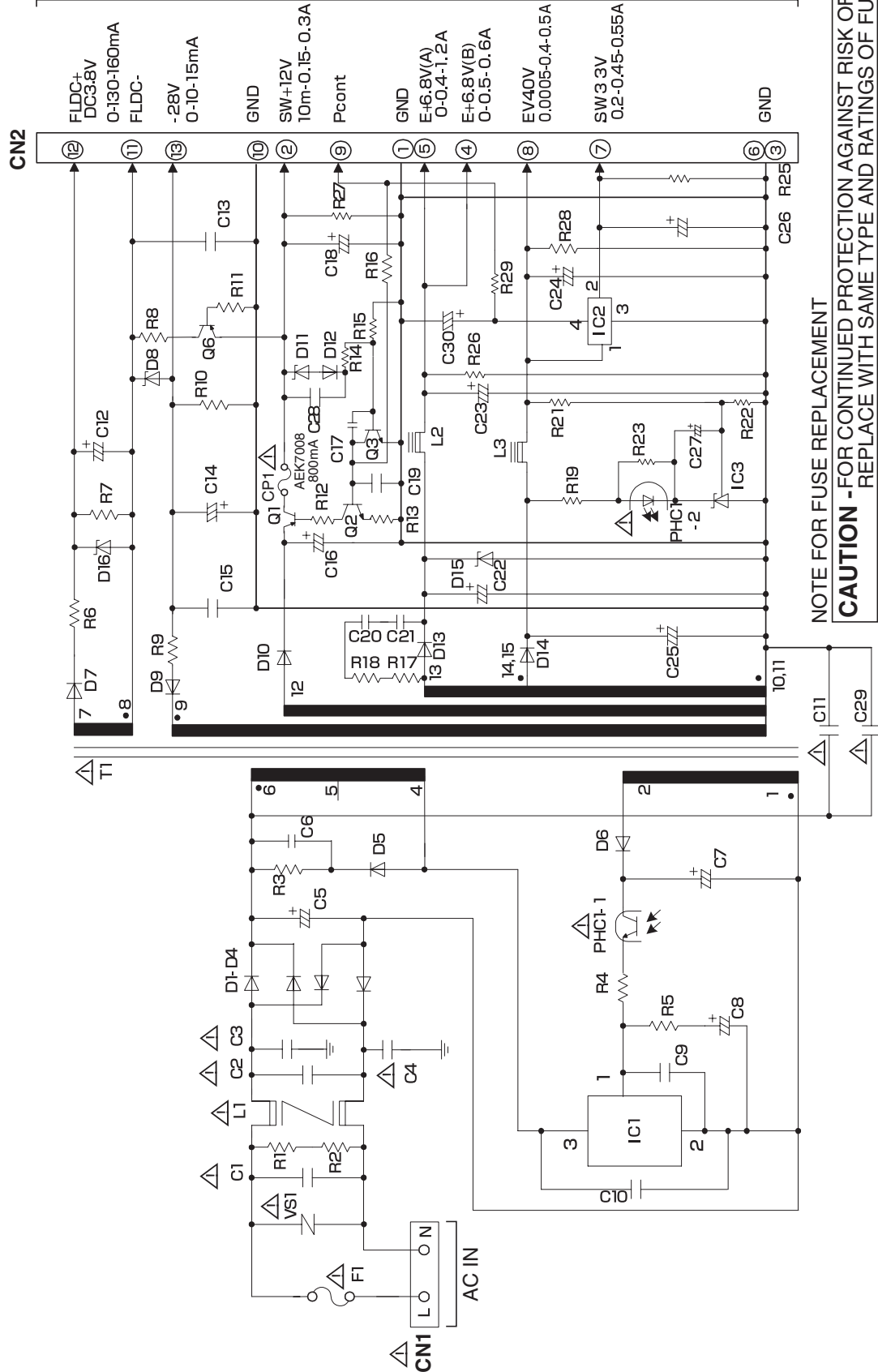

NOTE FOR FUSE REPLACEMENT

**CAUTION** - FOR CONTINUED PROTECTION AGAINST RISK OF FIRE:  
 REPLACE WITH SAME TYPE AND RATINGS OF FUSE.

1  
2  
3  
4  
5

A B C D

SCHEMATIC DIAGRAMS-1

1

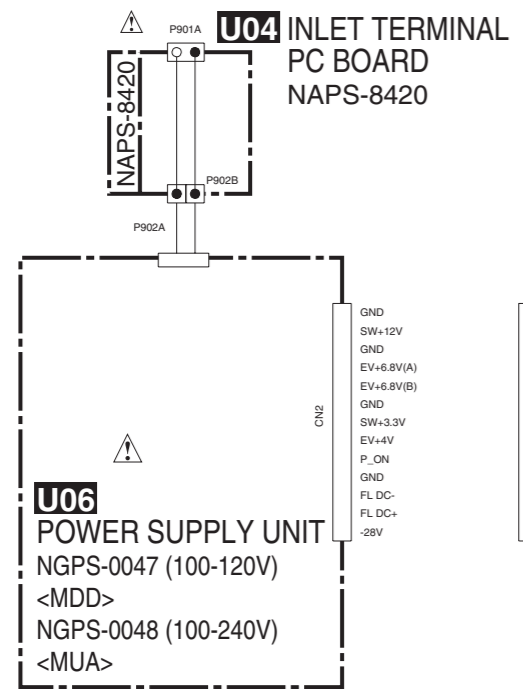

2

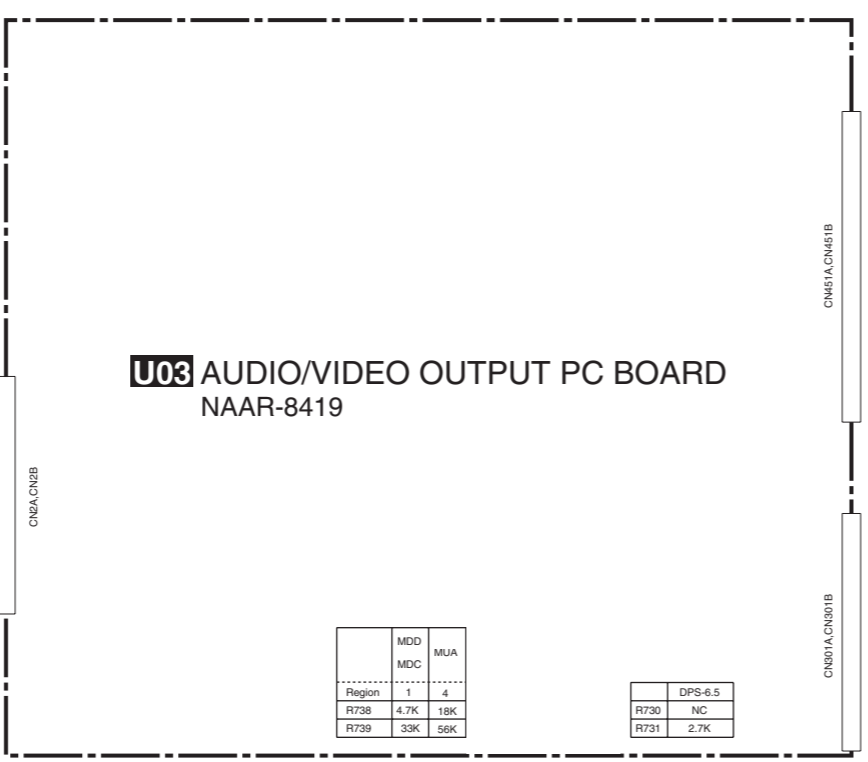

3

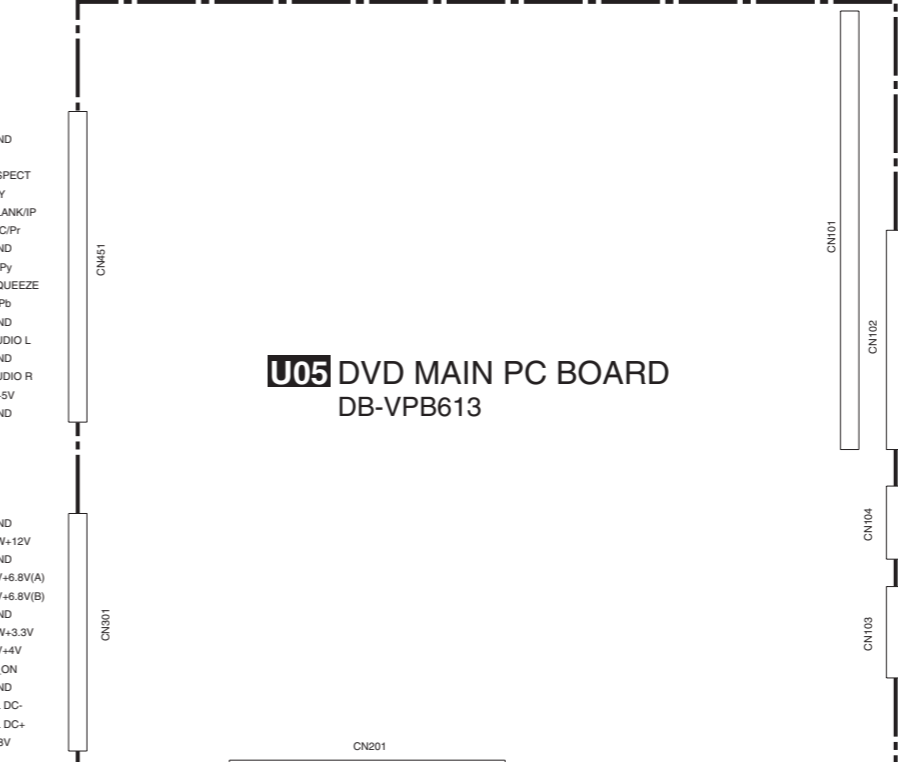

4

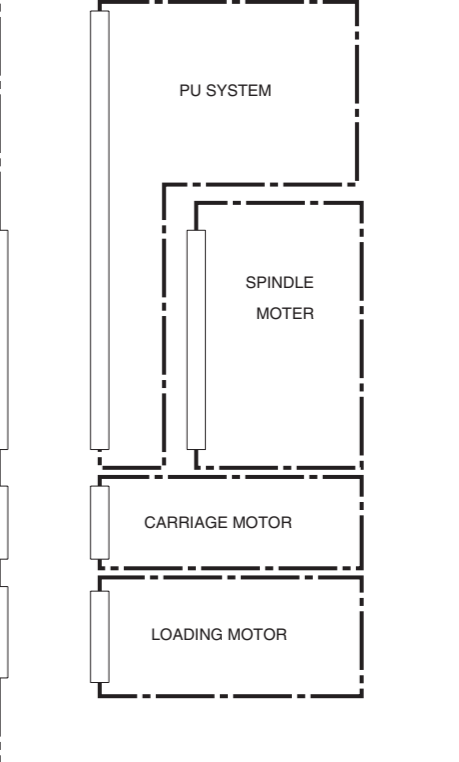

5

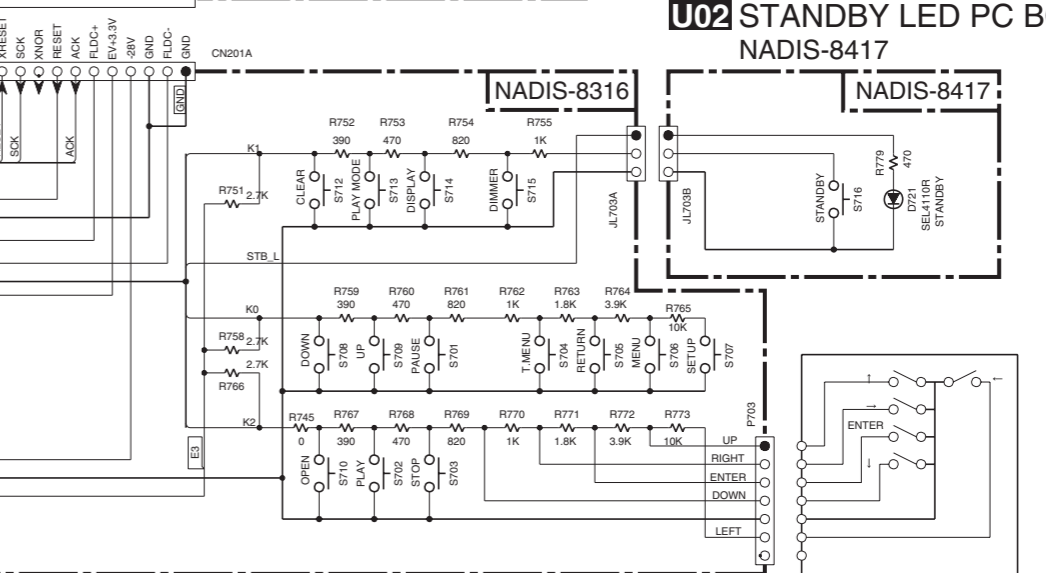
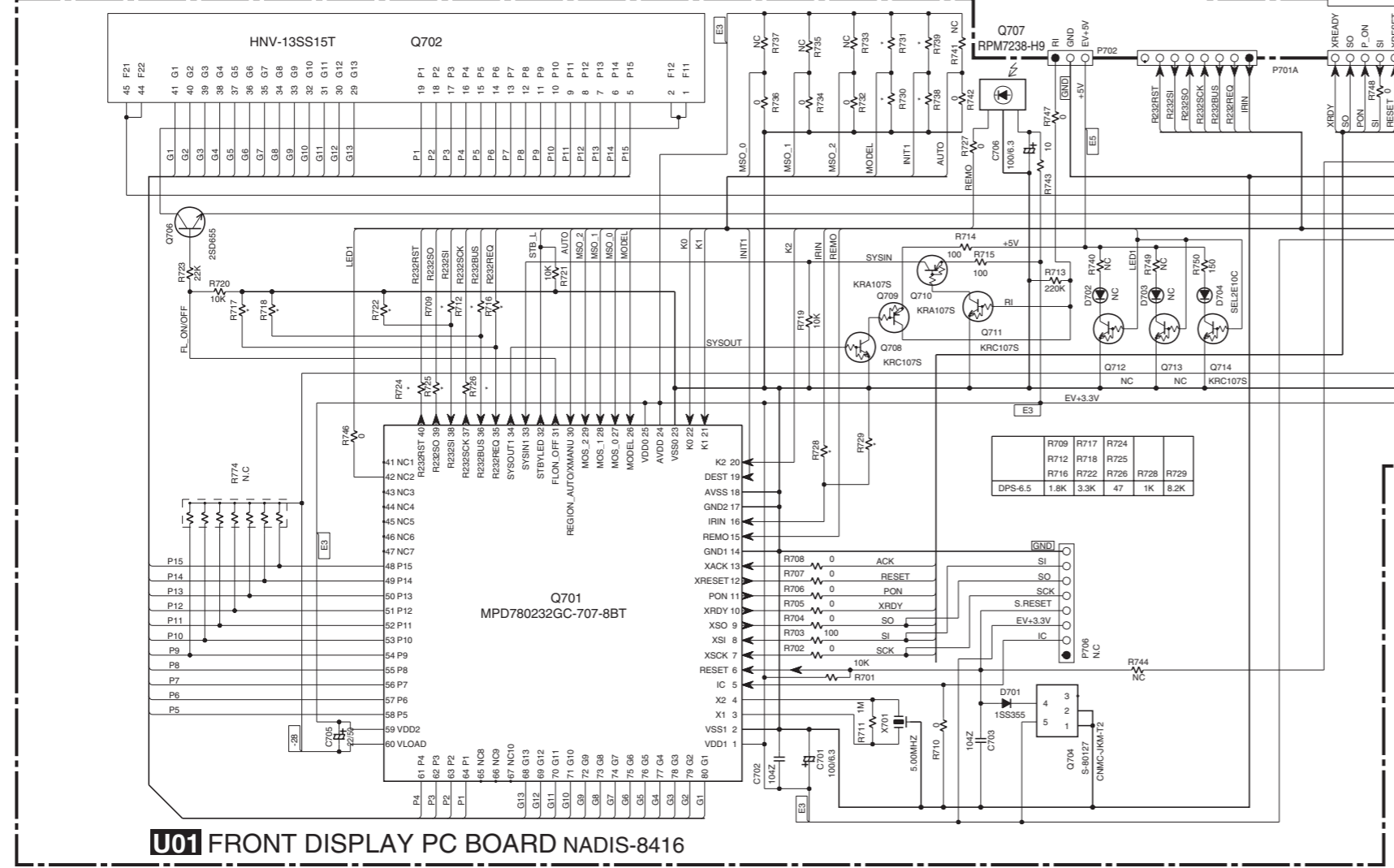

**NOTE**

- THE COMPONENTS IDENTIFIED BY MARK ARE CRITICAL FOR SAFETY FOR SAFETY. REPLACE ONLY WITH PART NUMBER SPECIFIED.
- VOLTAGE (MEASURED WITH VOLTMETER) IS DC VOLTAGE.(NO INPUT SIGNAL)
- ELECTROLYTIC CAPACITORS ( ) ARE IN uF/WV.
- ALL CAPACITORS ARE IN pF/50WV UNLESS OTHERWISE NOTED.
- EX) 030+3pF 330+33pF 331+330pF 333+0.033uF
- THE THICK LINES ON PC BOARD ARE THE PRINTING SIDE OF THE PARTS.
- EX) PRINTING SIDE
- CIRCUIT IS SUBJECT TO CHANGE FOR IMPROVEMENT.

**CAUTION**  
FOR CONTINUED PROTECTION AGAINST FIRE HAZARD, REPLACE ONLY WITH FUSE OF SAME TYPE AND RATING INDICATED.

**ATTENTION**  
AFIN D'ASSURER UNE PROTECTION PERMANENTE CONTRE LES RISQUES D'INCENDIE, REMPLACER UNIQUEMENT PAR UN FUSIBLE DE MEME TYPE ET CALIBRATION COMME INDIQUE.

THIS SYMBOL LOCATED NEAR THE FUSE INDICATES THAT THE FUSE USED IS SLOW OPERATING TYPE FOR CONTINUED PROTECTION AGAINST FIRE HAZARD. REPLACE WITH SAME TYPE FUSE. FOR FUSE RATING REFER TO THE MARKING ADJACENT TO THE SYMBOL.

CE SYMBOLE INDIQUE QUE LE FUSIBLE UTILISE EST E LENT.POUR UNE PROTECTION PERMANENTE,UTILISER QUE DES FUSIBLES DE MEME TYPE. CE DERNIER EST INDIQUE LA QU LE PRESENT SYMBOLE EST APPOSE.

# SCHEMATIC DIAGRAMS-2

## U03 AUDIO/VIDEO OUTPUT PC BOARD NAAR-8419

1  
2  
3  
4  
5

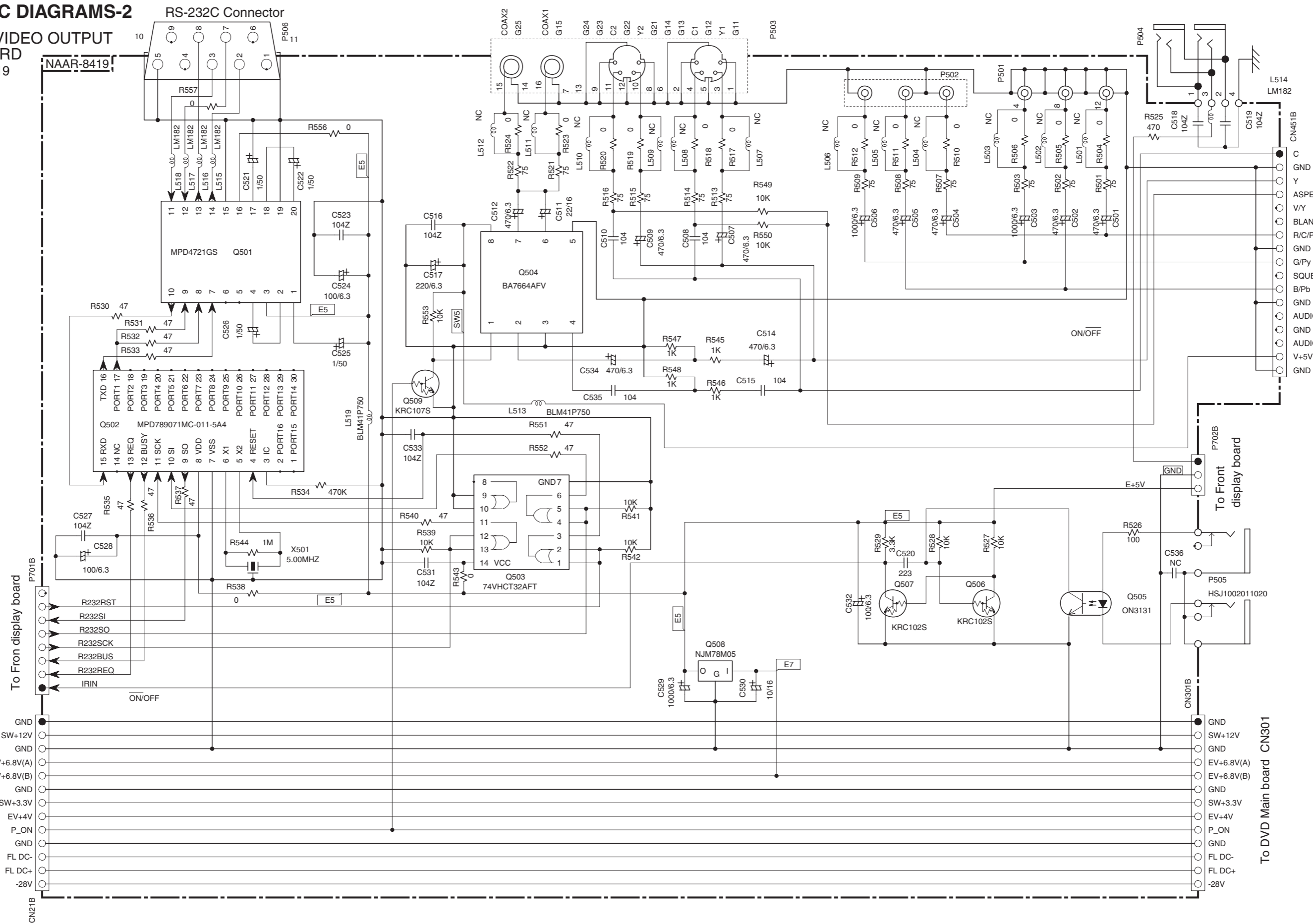

To DVD Main board CN541

To Front display board

To DVD Main board CN301

From Power supply unit CN2

SCHEMATIC DIAGRAMS-3

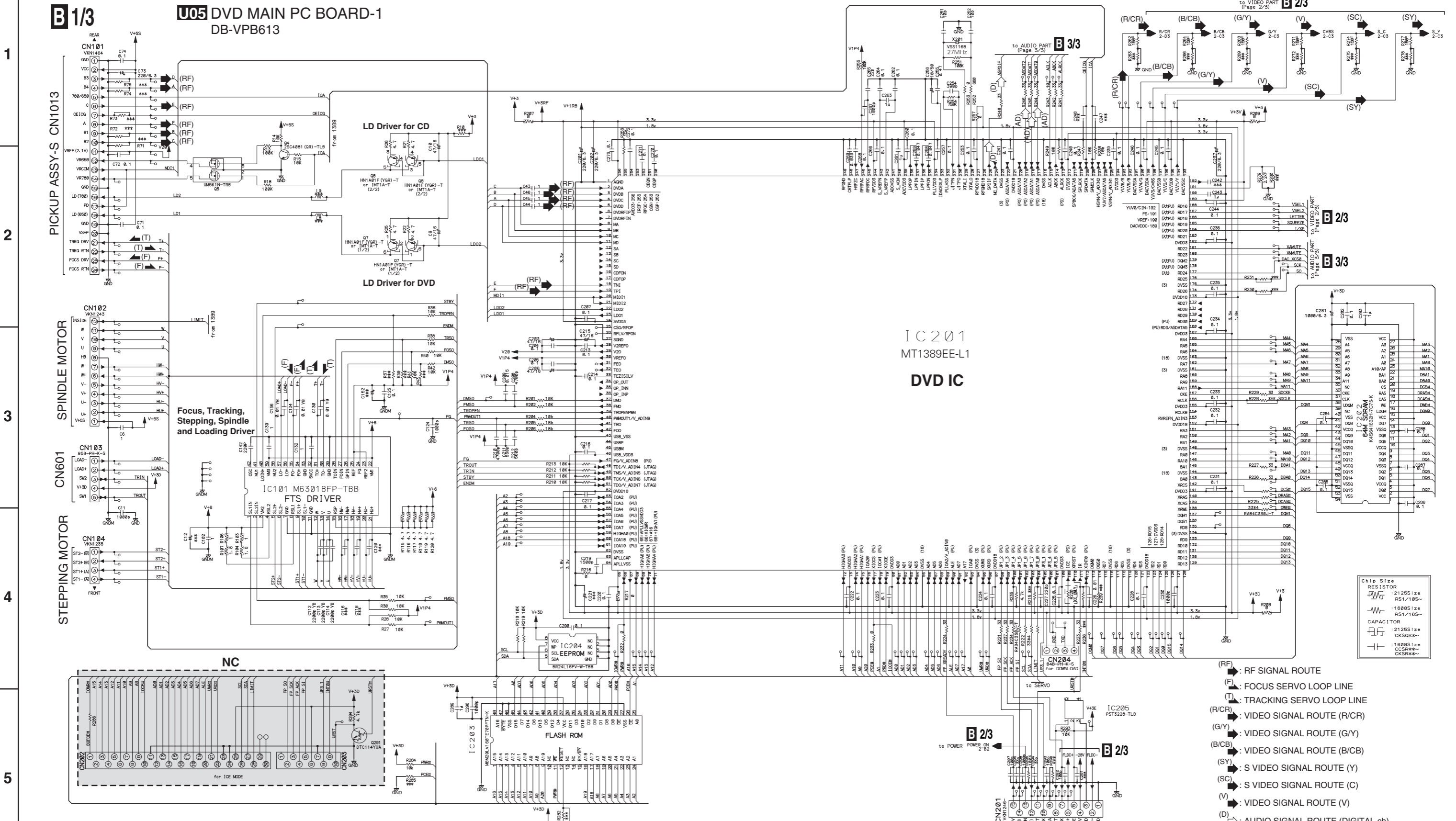

IC201  
MT1389EE-L1  
DVD IC

Chip Size	RESISTOR	2125Size
		R51/185~
		1689Size
		R51/165~
	CAPACITOR	2125Size
		CKSQ~
		1689Size
		CKSR~

- (RF) : RF SIGNAL ROUTE
- (F) : FOCUS SERVO LOOP LINE
- (T) : TRACKING SERVO LOOP LINE
- (R/CR) : VIDEO SIGNAL ROUTE (R/CR)
- (G/Y) : VIDEO SIGNAL ROUTE (G/Y)
- (B/CB) : VIDEO SIGNAL ROUTE (B/CB)
- (SY) : S VIDEO SIGNAL ROUTE (Y)
- (SC) : S VIDEO SIGNAL ROUTE (C)
- (V) : VIDEO SIGNAL ROUTE (V)
- (D) : AUDIO SIGNAL ROUTE (DIGITAL ch)
- (AD) : AUDIO DATA SIGNAL ROUTE

B 1/3

B 1/3



A B C D E F G H

SCHEMATIC DIAGRAMS-5

B 3/3 U05 DVD MAIN PC BOARD-3 DB-VPB613

1

2

3

4

5

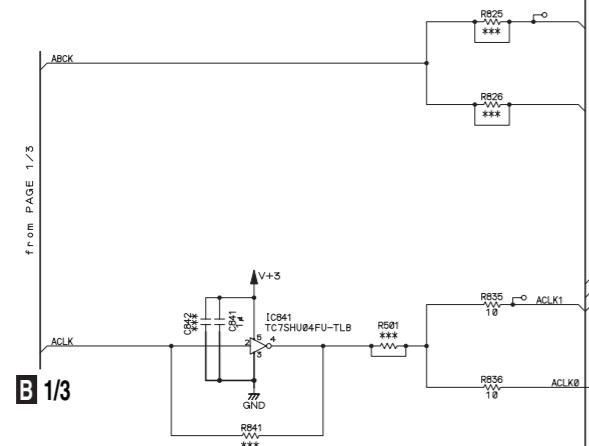
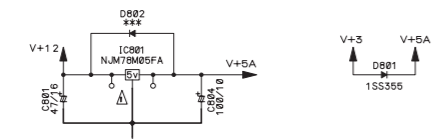
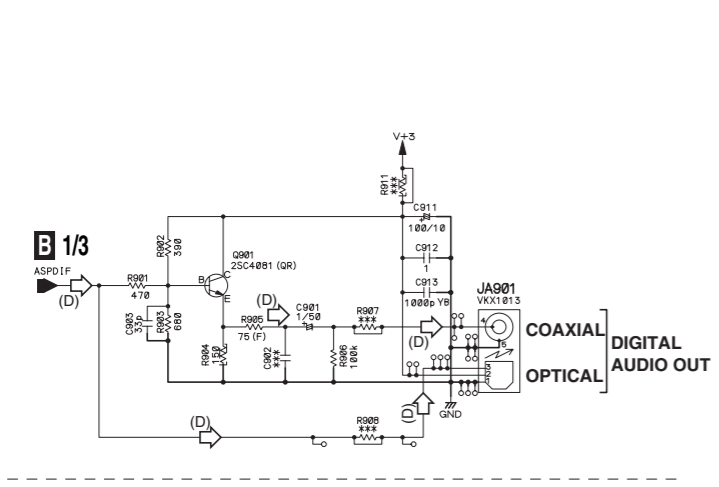

- (AD) : AUDIO DATA SIGNAL ROUTE
- (D) : AUDIO SIGNAL ROUTE (DIGITAL ch)
- (FL) : AUDIO SIGNAL ROUTE (Front L ch)
- (SL) : AUDIO SIGNAL ROUTE (Surround L ch)
- (C) : AUDIO SIGNAL ROUTE (Center ch)
- (SW) : AUDIO SIGNAL ROUTE (Sub Woofer ch)

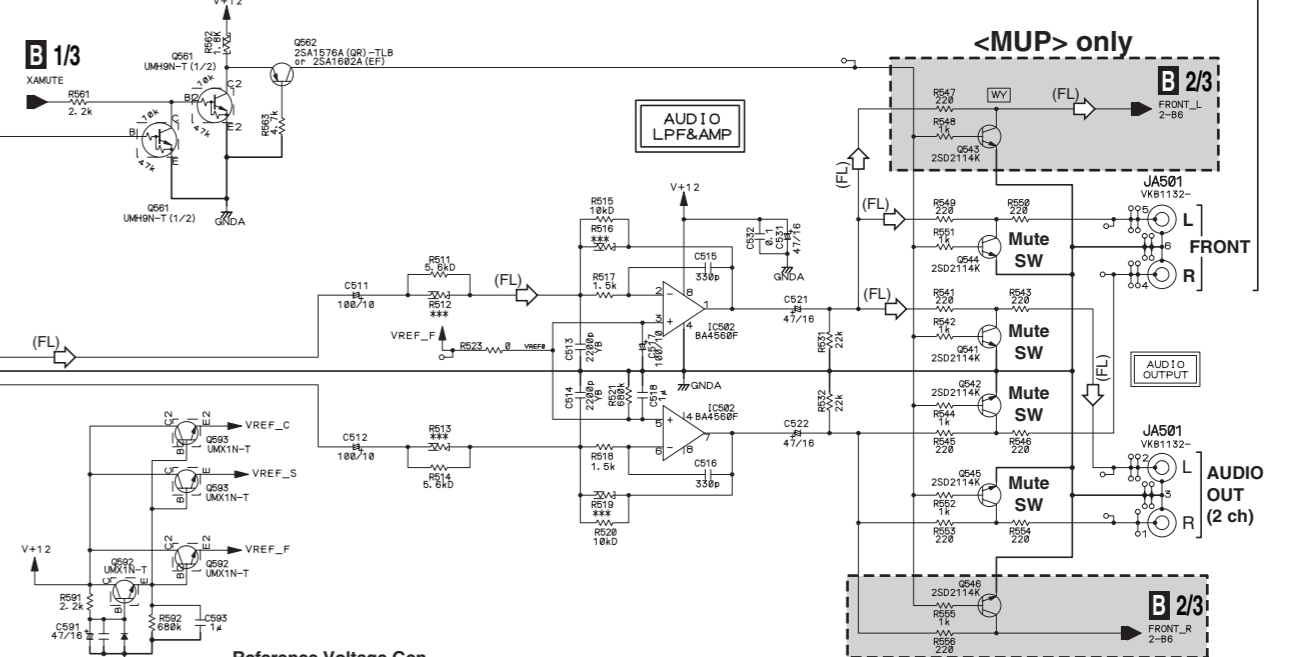
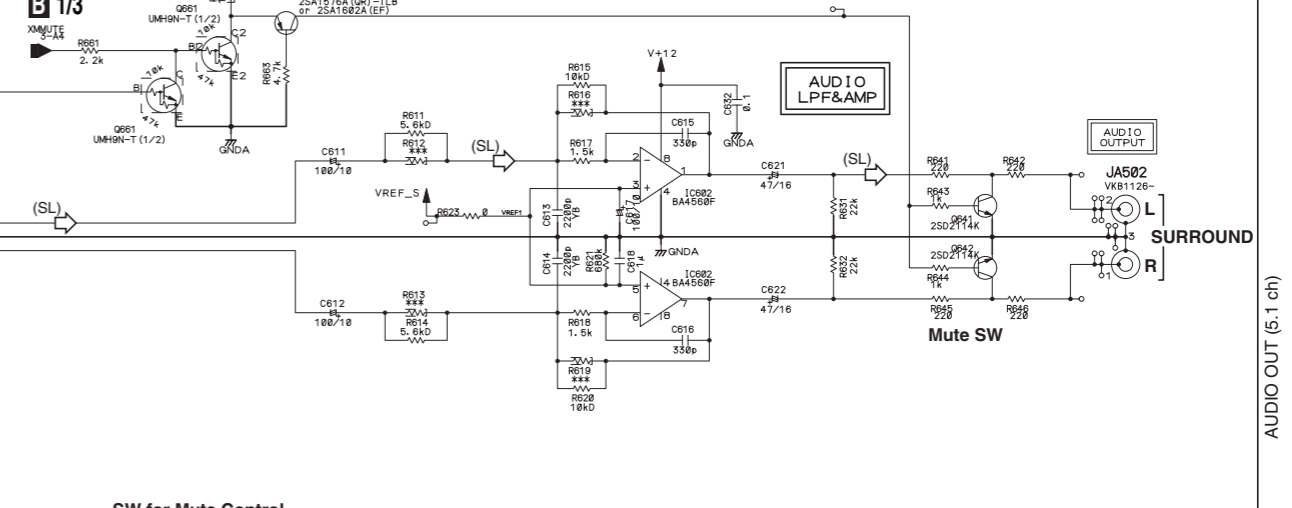
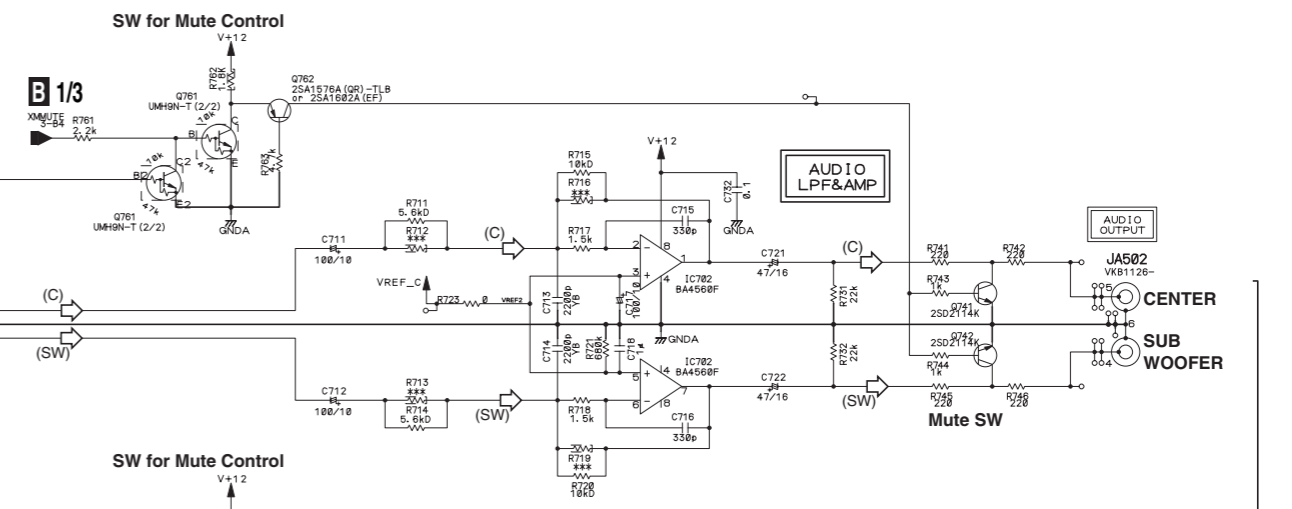
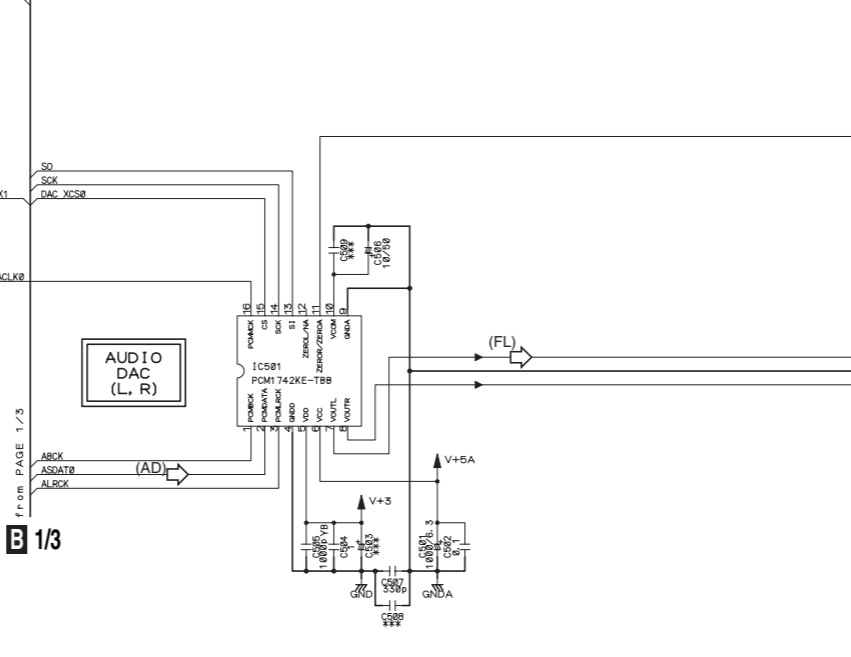
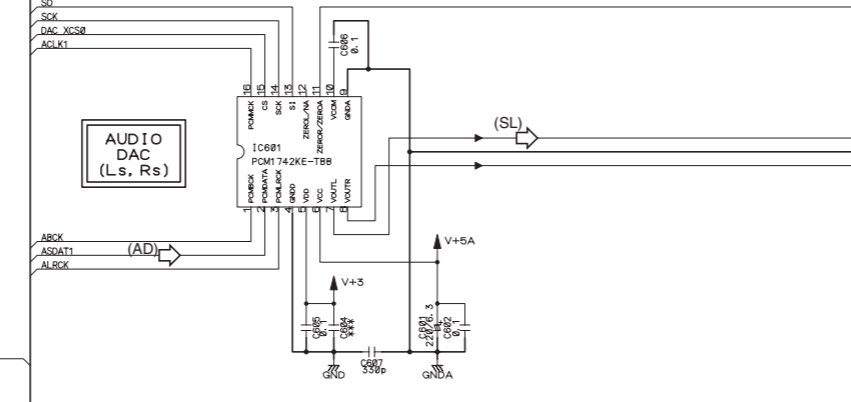
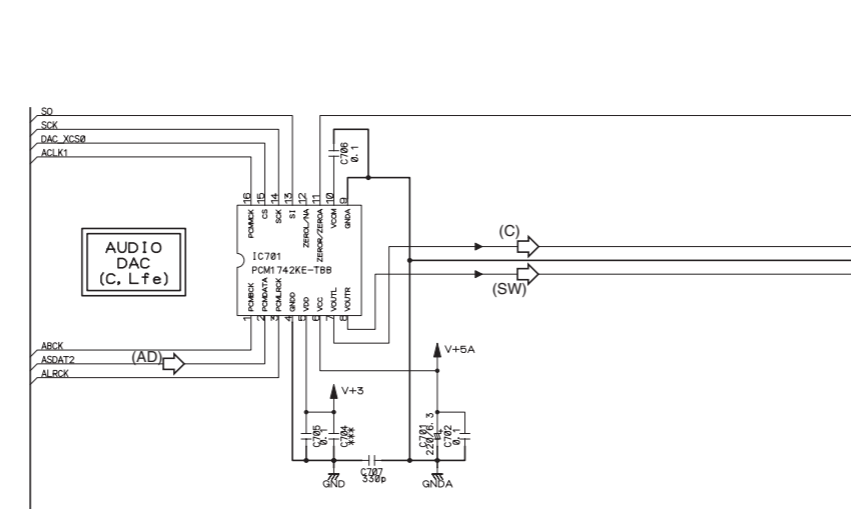

B 3/3

B 3/3

AUDIO OUT (5.1 ch)

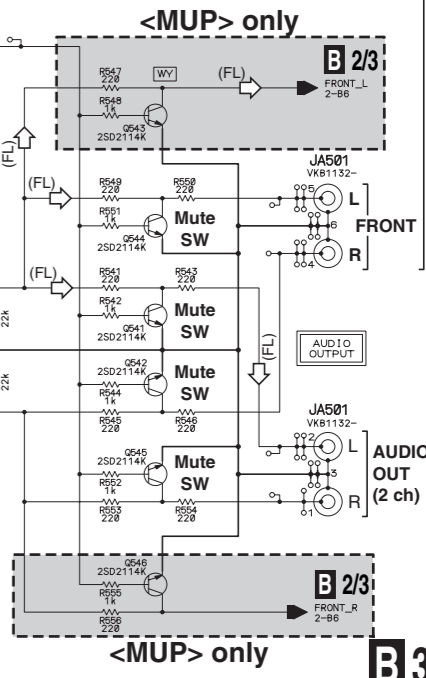

# PC BOARD CONNECTION DIAGRAM

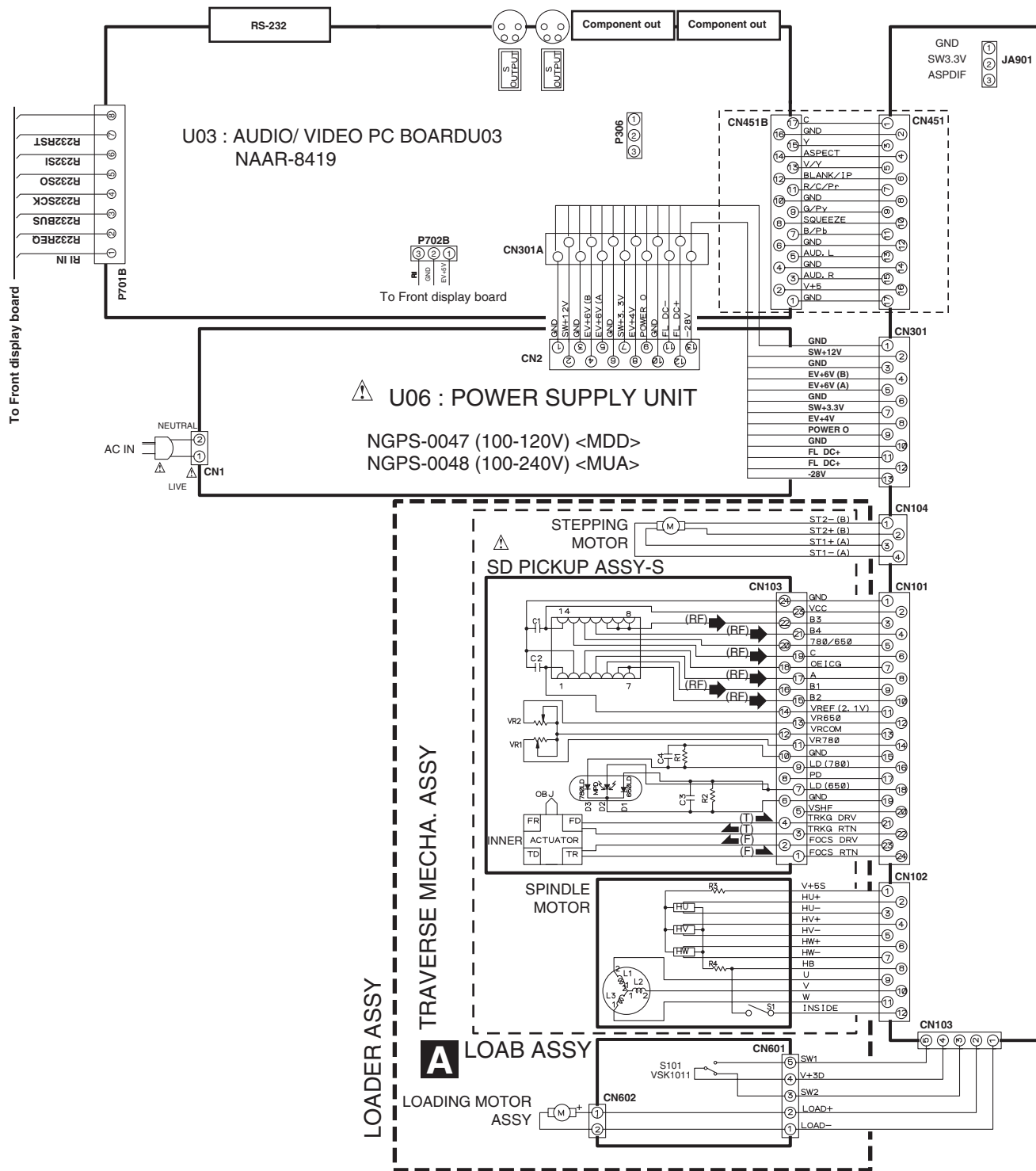

U05

(RF) : RF SIGNAL ROUTE  
 (F) : FOCUS SERVO LOOP LINE  
 (T) : TRACKING SERVO LOOP LINE

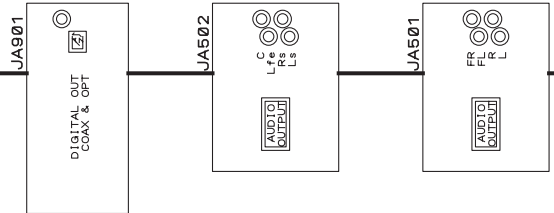

U05 : DVD MAIN BOARD DB-VPB613

U02 : STADBY LED BOARD  
 NADIS-8417

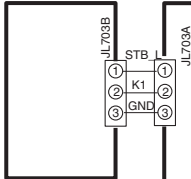

From Audo/video output board

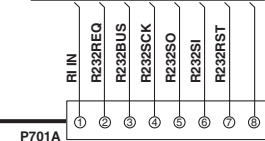

U01 : FRONT DISPLAY PC BOARD  
 NADIS-8416

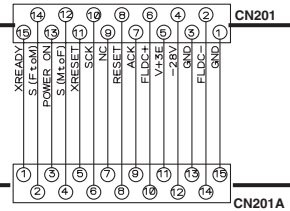

P701A

CN201

CN201A



# PC BOARD CONNECTION DIAGRAM

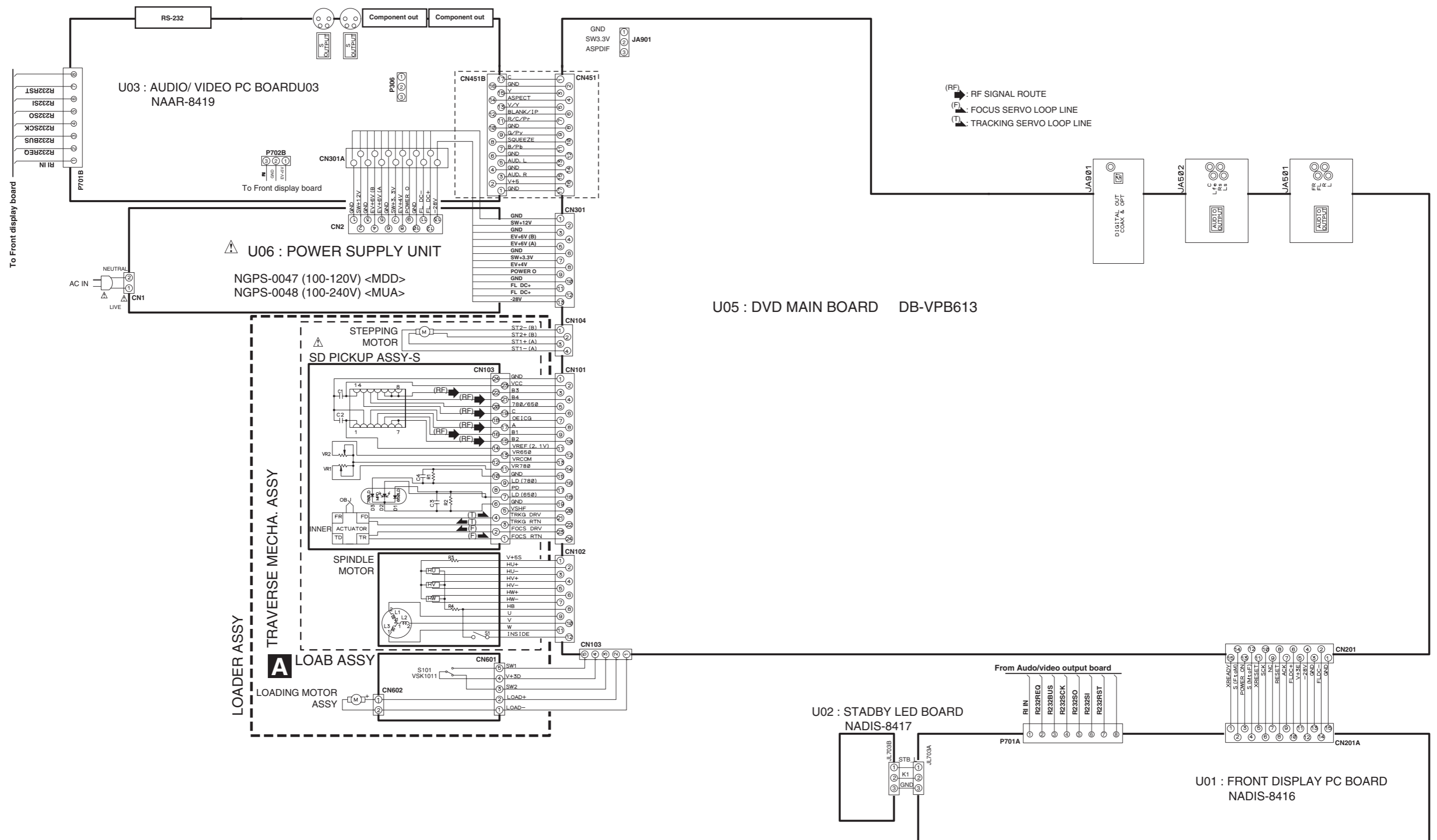

A

B

C

D

# PRINTED CIRCUIT BOARD VIEWS-1

## U01 FRONT DISPLAY PC BOARD (NADIS-8416)

1

Component side view from soldering side

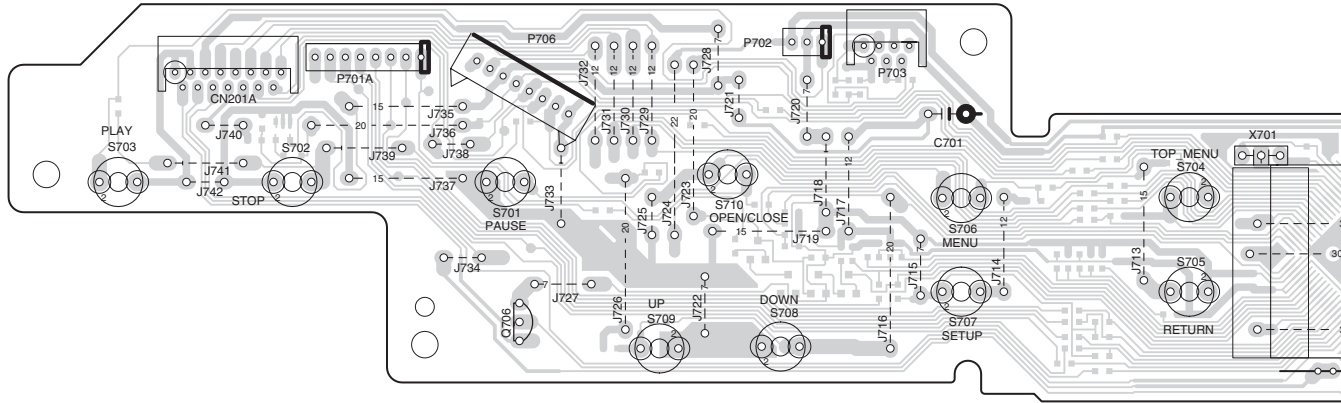

2

Soldering side

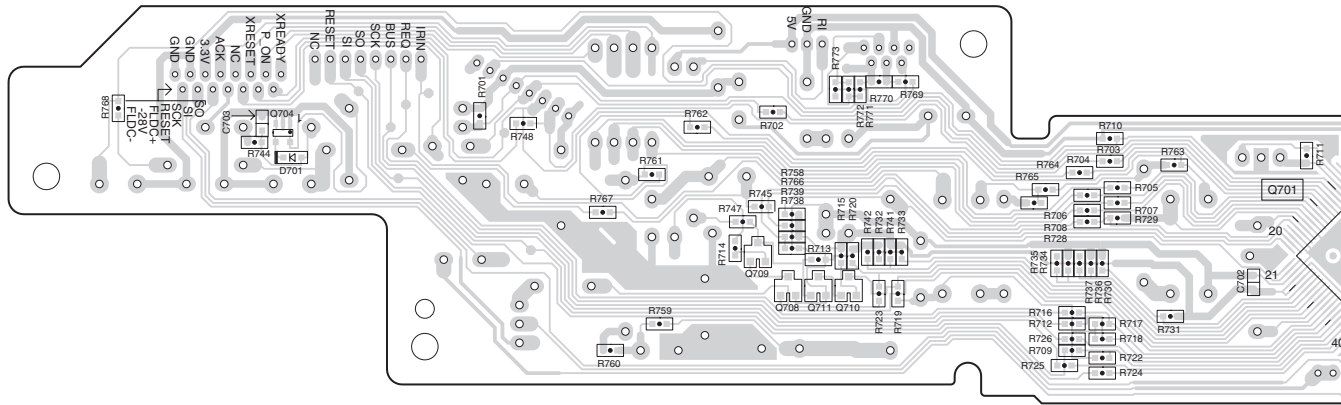

3

4

## U02 STANDBY LED PC BOARD (NADIS-8417)

Component side view from soldering side

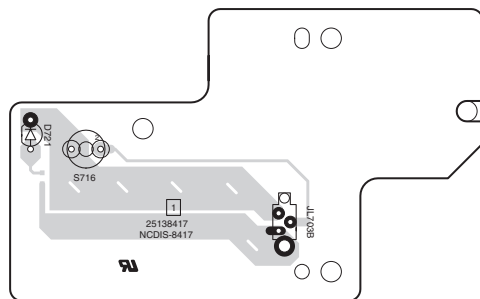

Soldering side

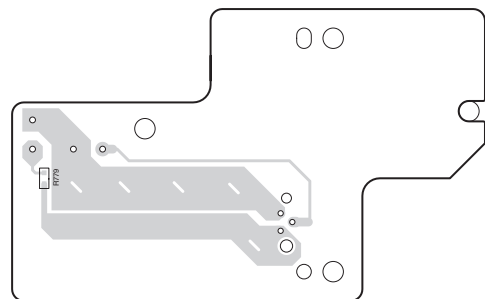

5

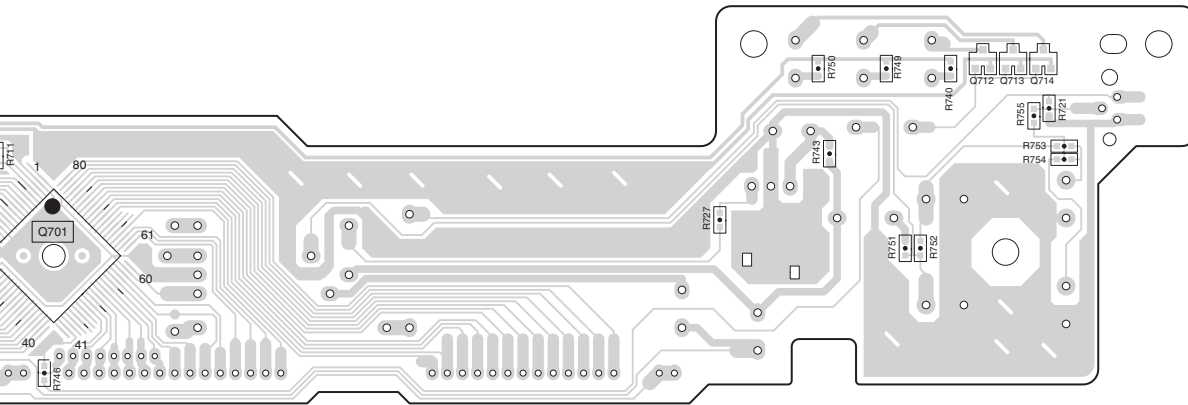
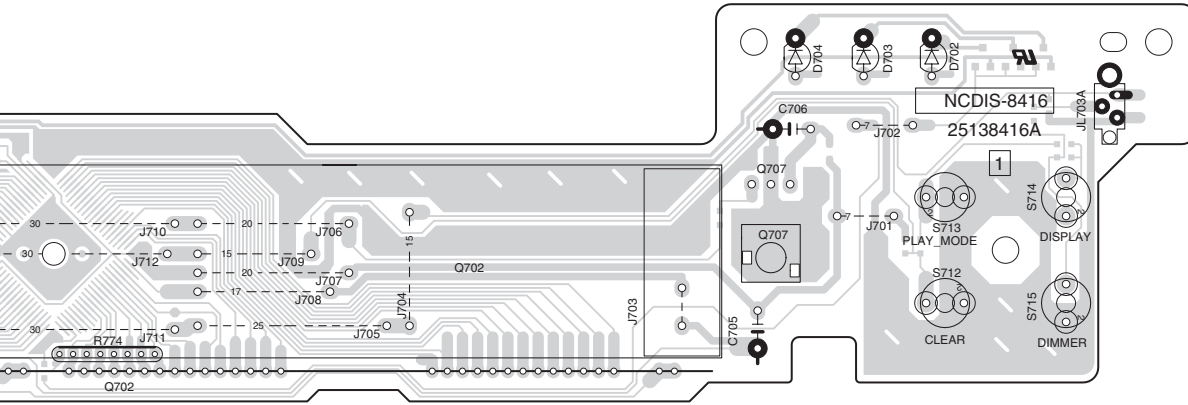

**U04 INLET TERMINAL PC BOARD (NAPS-8420)**

Component side view from soldering side

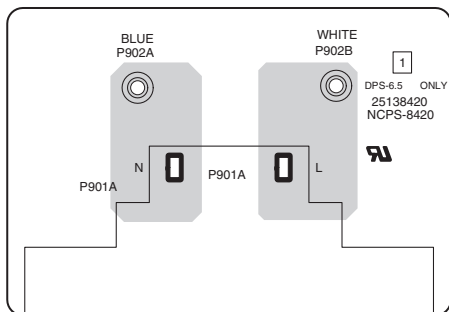

A

B

C

D

PRINTED CIRCUIT BOARD VIEWS-2

U03 AUDIO / VIDEO OUTPUT PC BOARD (NAAR-8419)

1

Component side view from soldering side

Soldering side

2

3

4

5

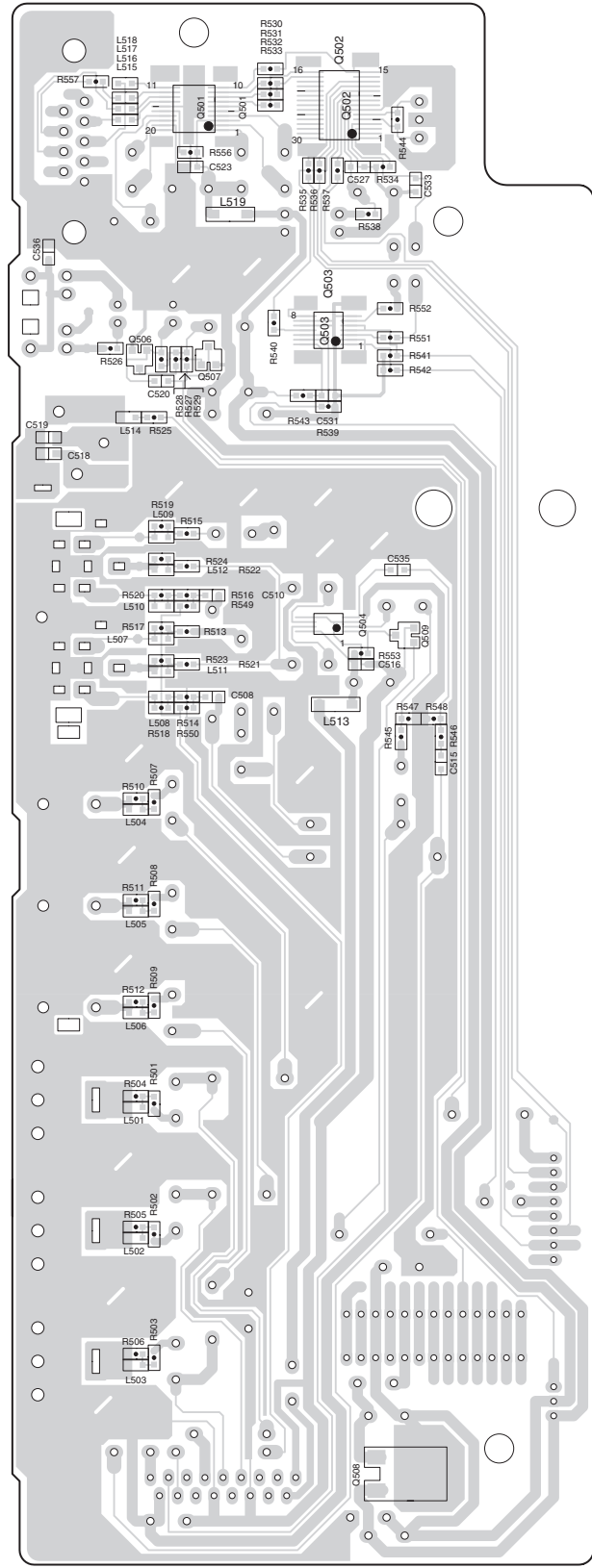
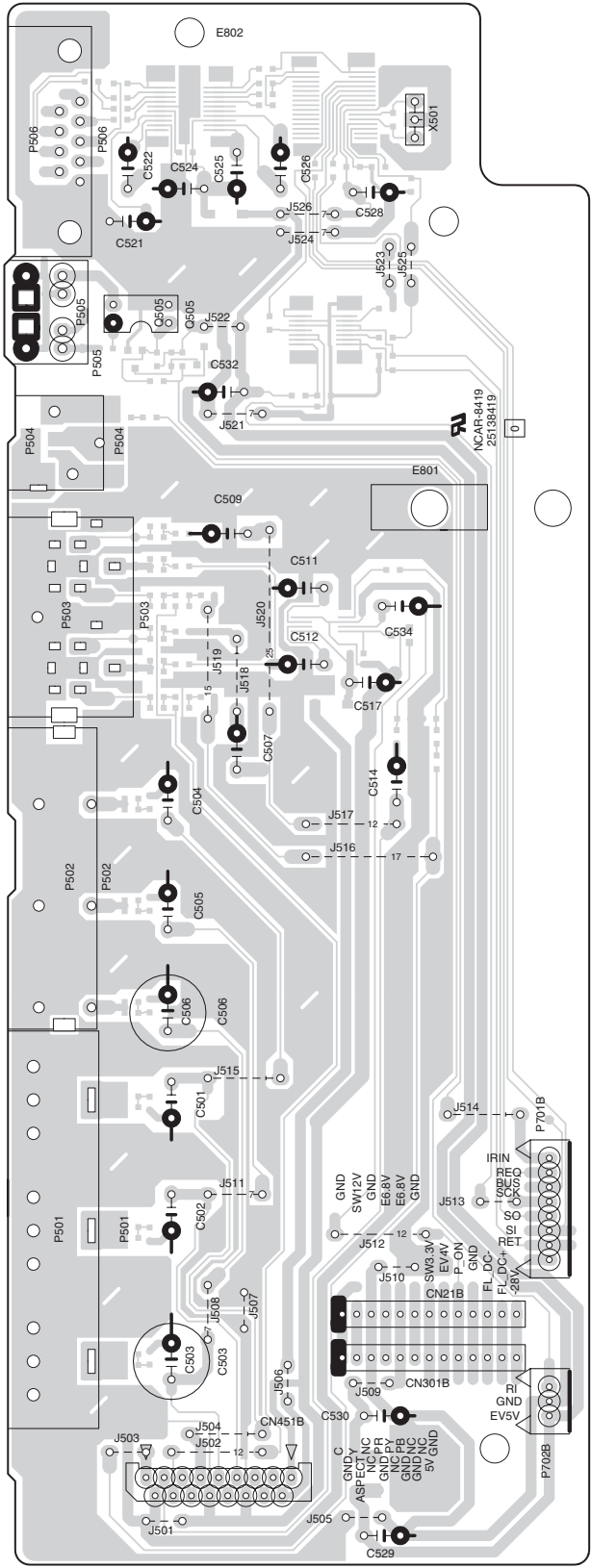

A

B

C

D

# PRINTED CIRCUIT BOARD VIEWS-3

**U05** DVD MAIN PC BOARD  
DB-VPB613

1

Top View

**SIDE A**

**B** DVDM ASSY

M SPINDLE MOTOR  
03 SD PICKUP ASSY-S  
M STEPPING MOTOR  
CN2

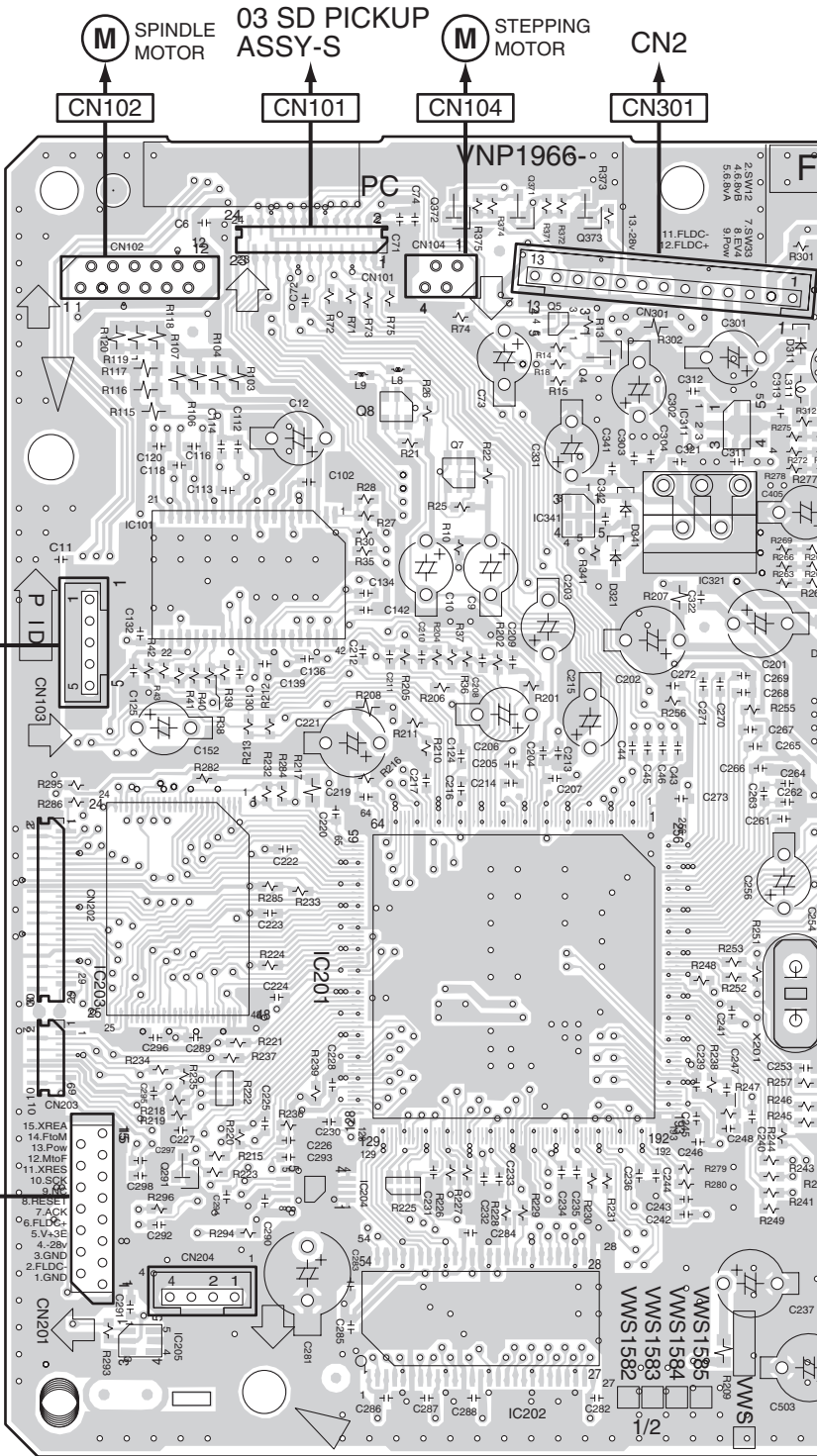

2

3

4

5

CN601

CN103

CN101

CN201

IC203 IC101 IC204 Q8 Q372 Q371 Q373 IC311  
Q291 IC204 Q7 Q5 Q4 IC321  
IC205 IC202 IC201 IC341

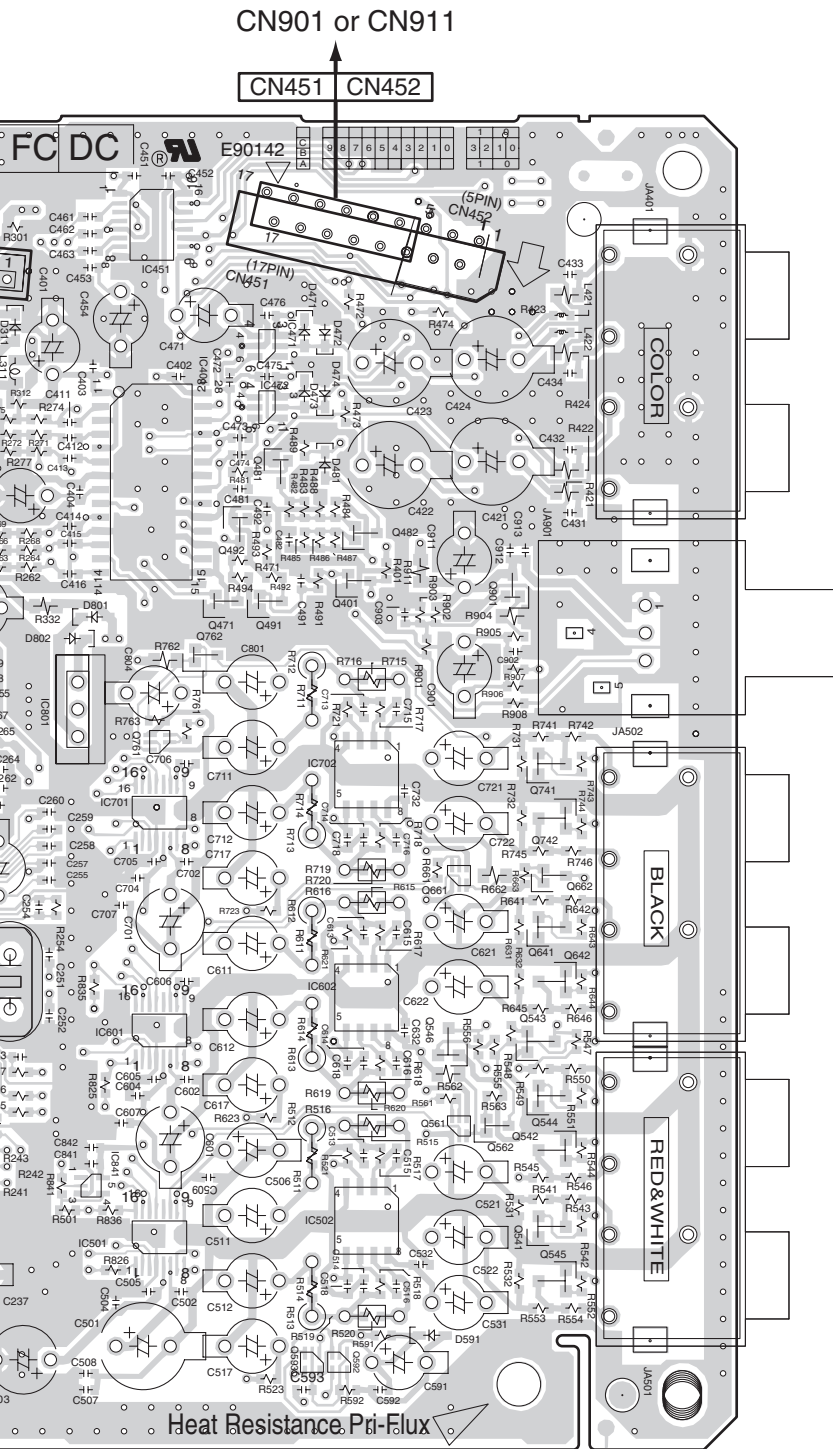

IC801	IC401	IC471	Q482	Q661	Q901	Q741
IC841	Q761	Q481	Q401	Q546	Q742	Q662
IC701	Q492	IC602	Q561	Q562	Q641	Q642
IC601	Q471	Q491	IC502			
IC501	Q762	Q593	Q592			Q541-Q545

A

B

C

D

# PRINTED CIRCUIT BOARD VIEWS-4

**U05** DVD MAIN PC BOARD  
DB-VPB613

**SIDE B**

Bottom View

**CN451** **CN452**

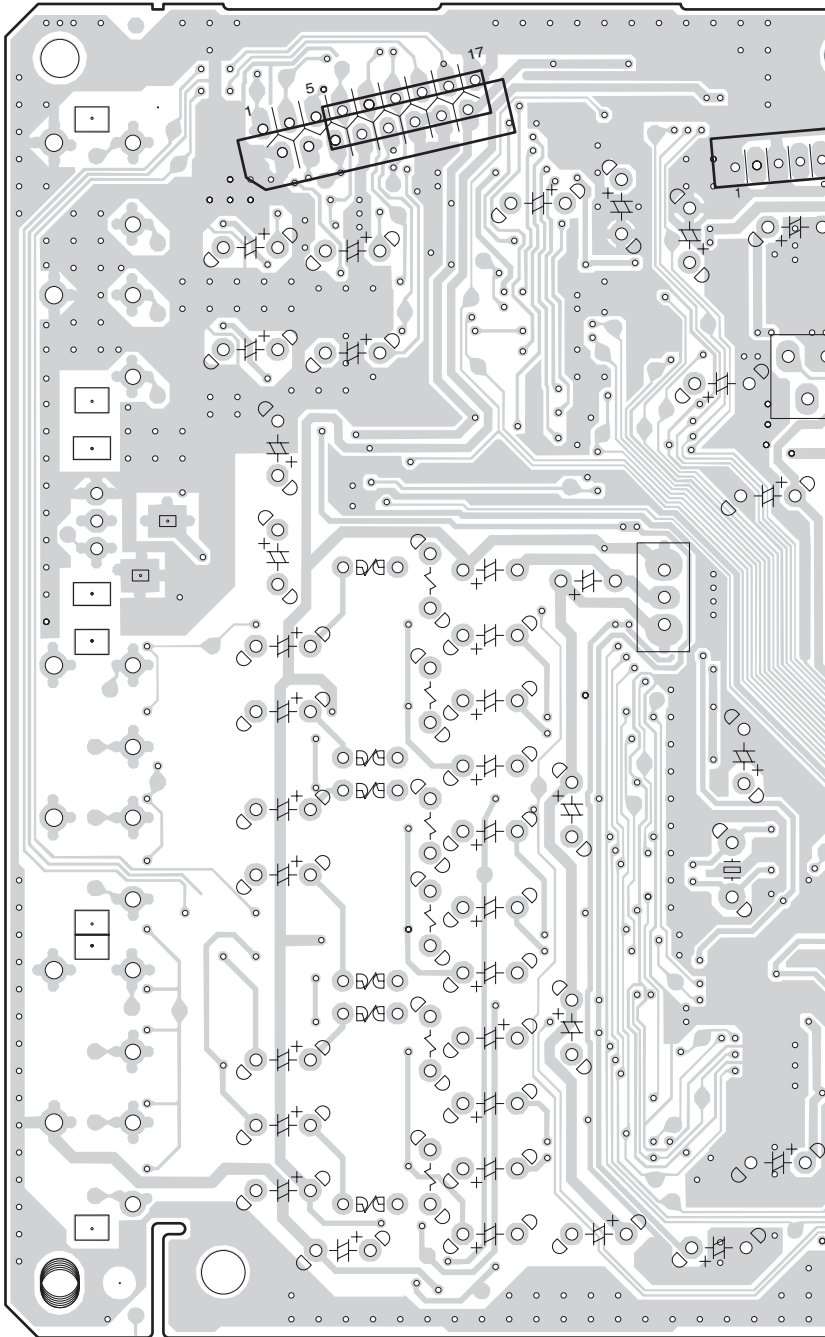

1

2

3

4

5

E

F

G

H

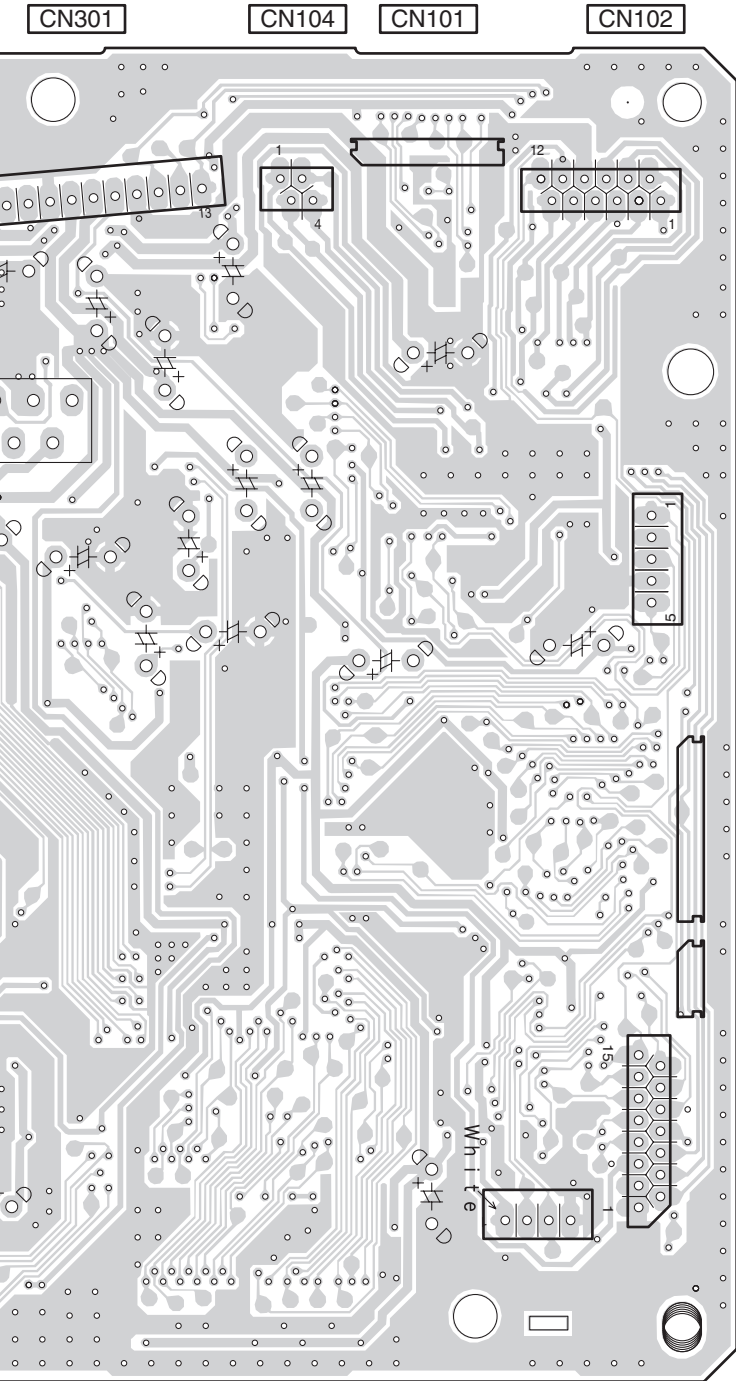

**B** DVDM ASSY



A

B

C

D

PRINTED CIRCUIT BOARD VIEWS-5

LOAD PC BOARD

1

SIDE A

SIDE B

2

**A** LOAB ASSY

**A** LOAB ASSY

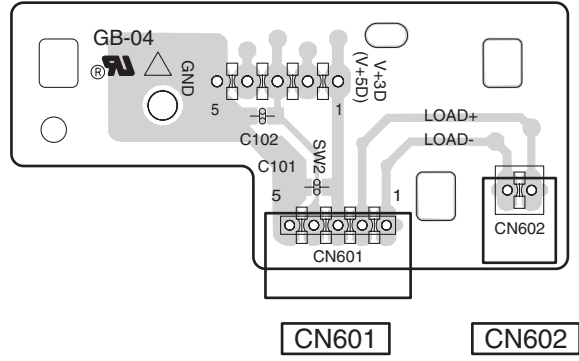
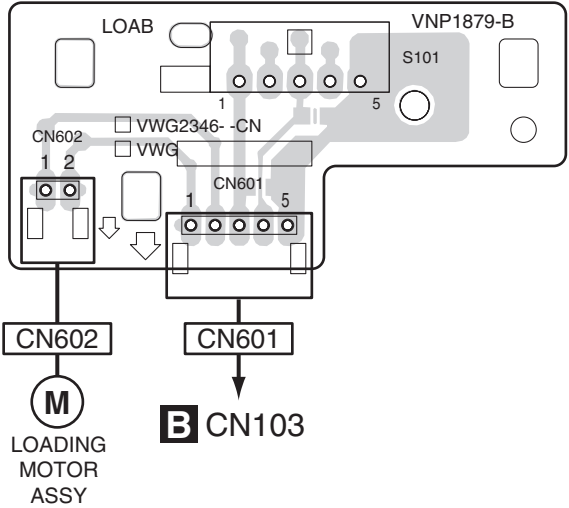

3



**B** CN103

4

5

A B C D E F G H  
PRINTED CIRCUIT BOARD VIEWS-1

1 **U01 FRONT DISPLAY PC BOARD (NADIS-8416)**

Component side view from soldering side

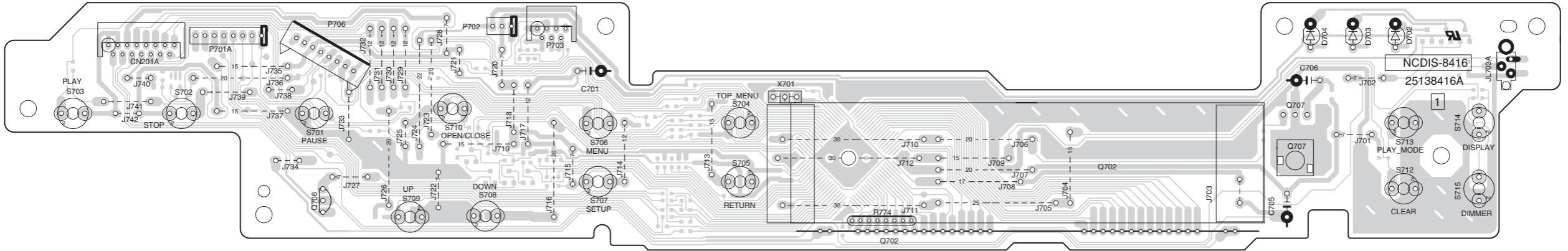

Soldering side

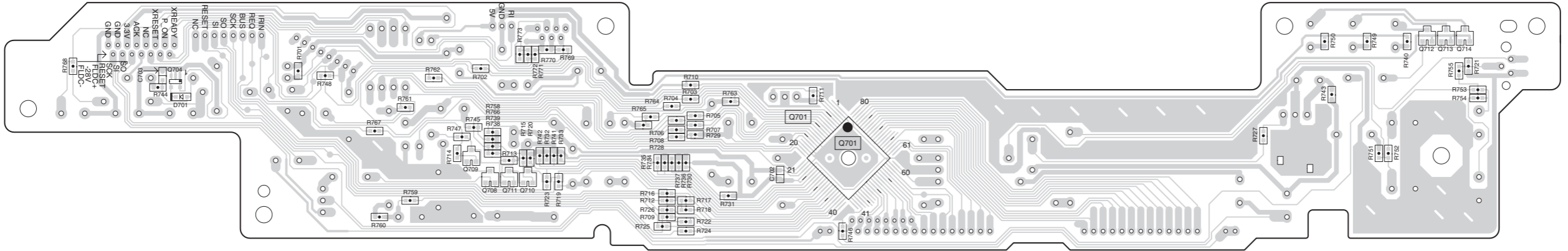

4 **U02 STANDBY LED PC BOARD (NADIS-8417)**

Component side view from soldering side

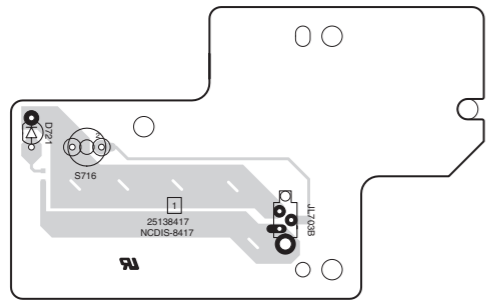

Soldering side

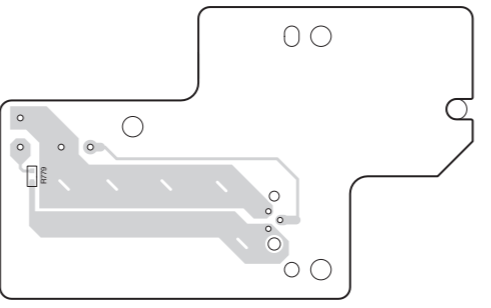

4 **U04 INLET TERMINAL PC BOARD (NAPS-8420)**

Component side view from soldering side

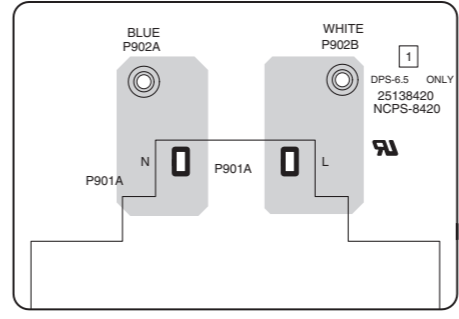

5

A B C D E F G H

PRINTED CIRCUIT BOARD VIEWS-3

U05 DVD MAIN PC BOARD DB-VPB613

SIDE A

B DVDM ASSY

Top View

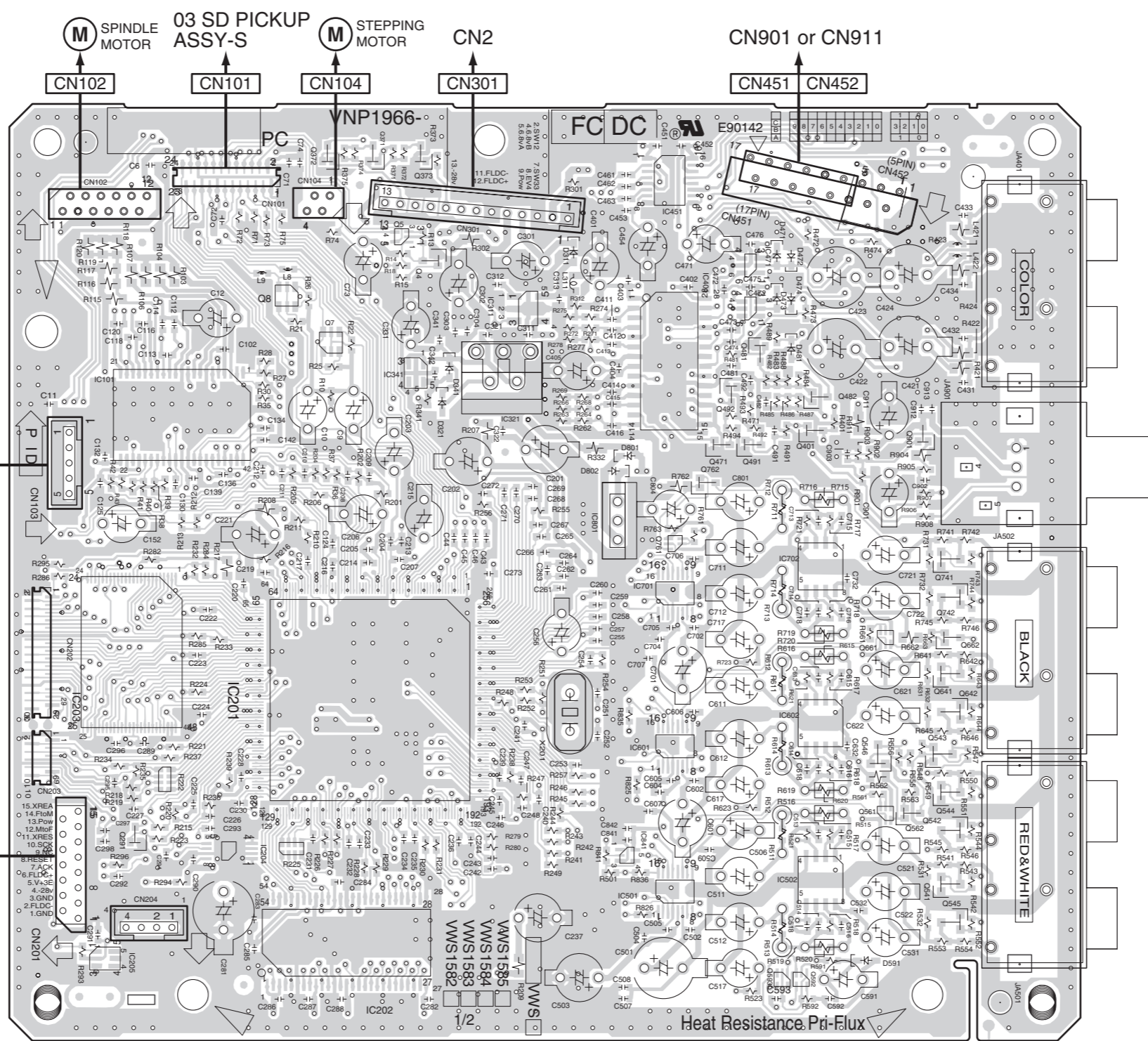

IC203	IC101	Q8	Q372	Q371	Q373	IC311	IC451	IC471	Q482	Q661	Q901	Q741
Q291	IC204	Q7	Q7	Q5	Q4	IC321	IC801	IC401	Q401	Q546	Q742	Q662
IC205		IC202	IC201	IC341			IC841	Q761	Q481	IC702	Q561	Q562
								IC701	Q492	IC602	Q561	Q562
								IC601	Q471	Q491	IC502	Q642
								IC501	Q762	Q593	Q592	Q541-Q545

1  
2  
3  
4  
5

A B C D E F G H

PRINTED CIRCUIT BOARD VIEWS-4

**U05** DVD MAIN PC BOARD  
DB-VPB613

**SIDE B**

1  
2  
3  
4  
5

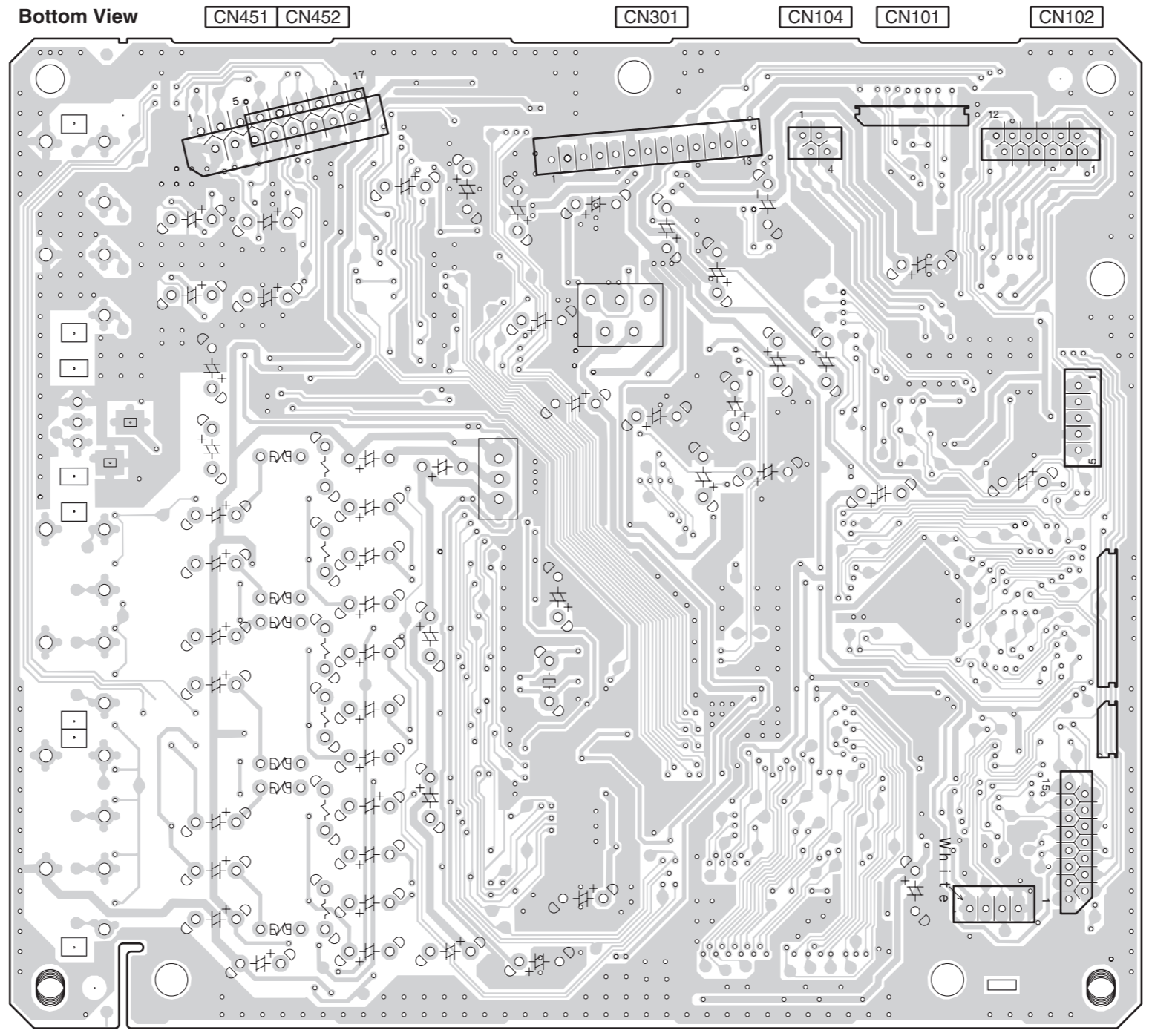

**B** DVDM ASSY

# IC BLOCK DIAGRAM/TERMINAL DESCRIPTIONS

## MT1389EE-L1 (DVDM ASSY : IC201)

DVD IC-1

### Pin Arrangement

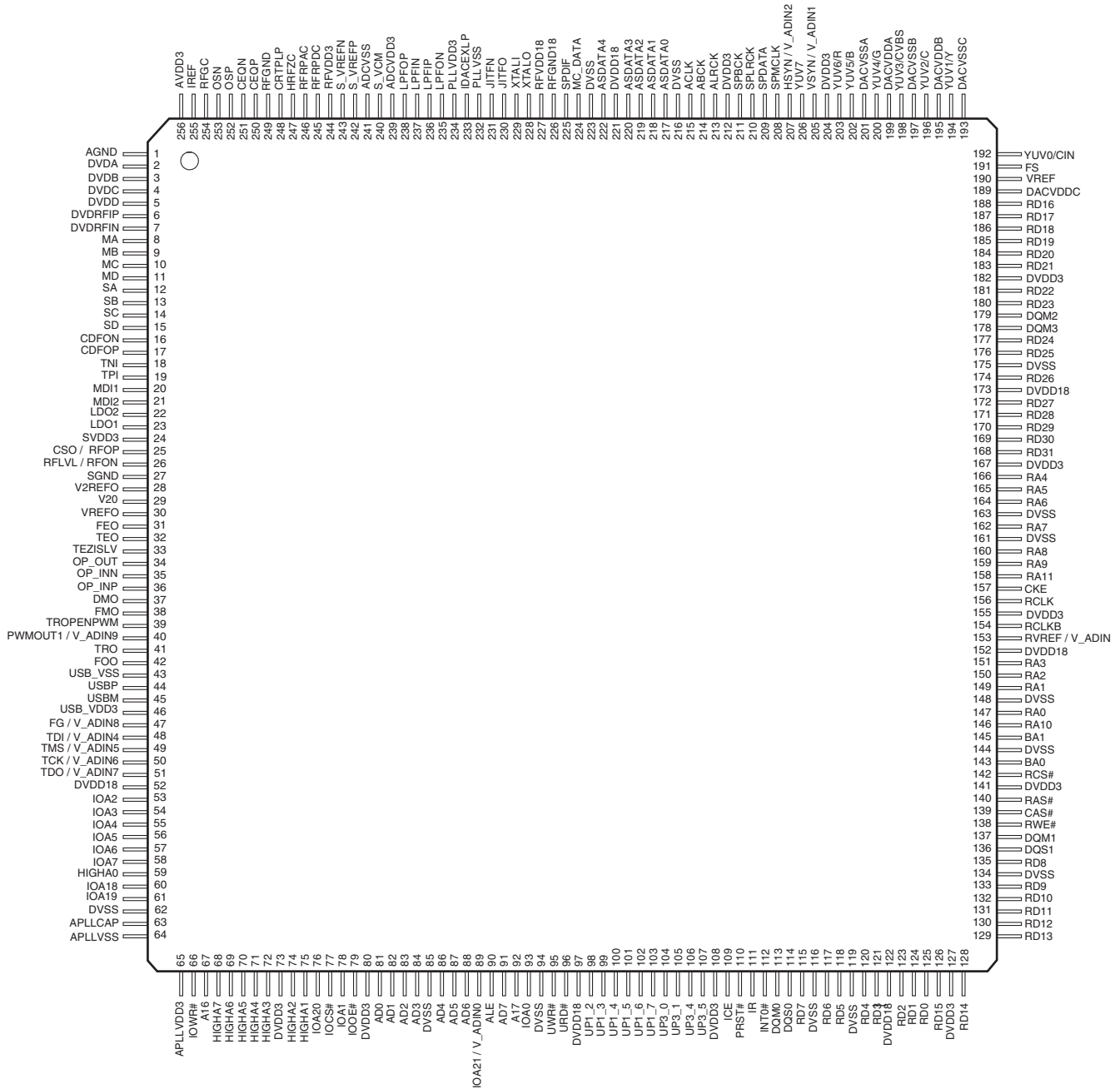

# IC BLOCK DIAGRAM/TERMINAL DESCRIPTIONS

## MT1389EE-L1 (DVDM ASSY : IC201)

DVD IC-2

### Block Diagram

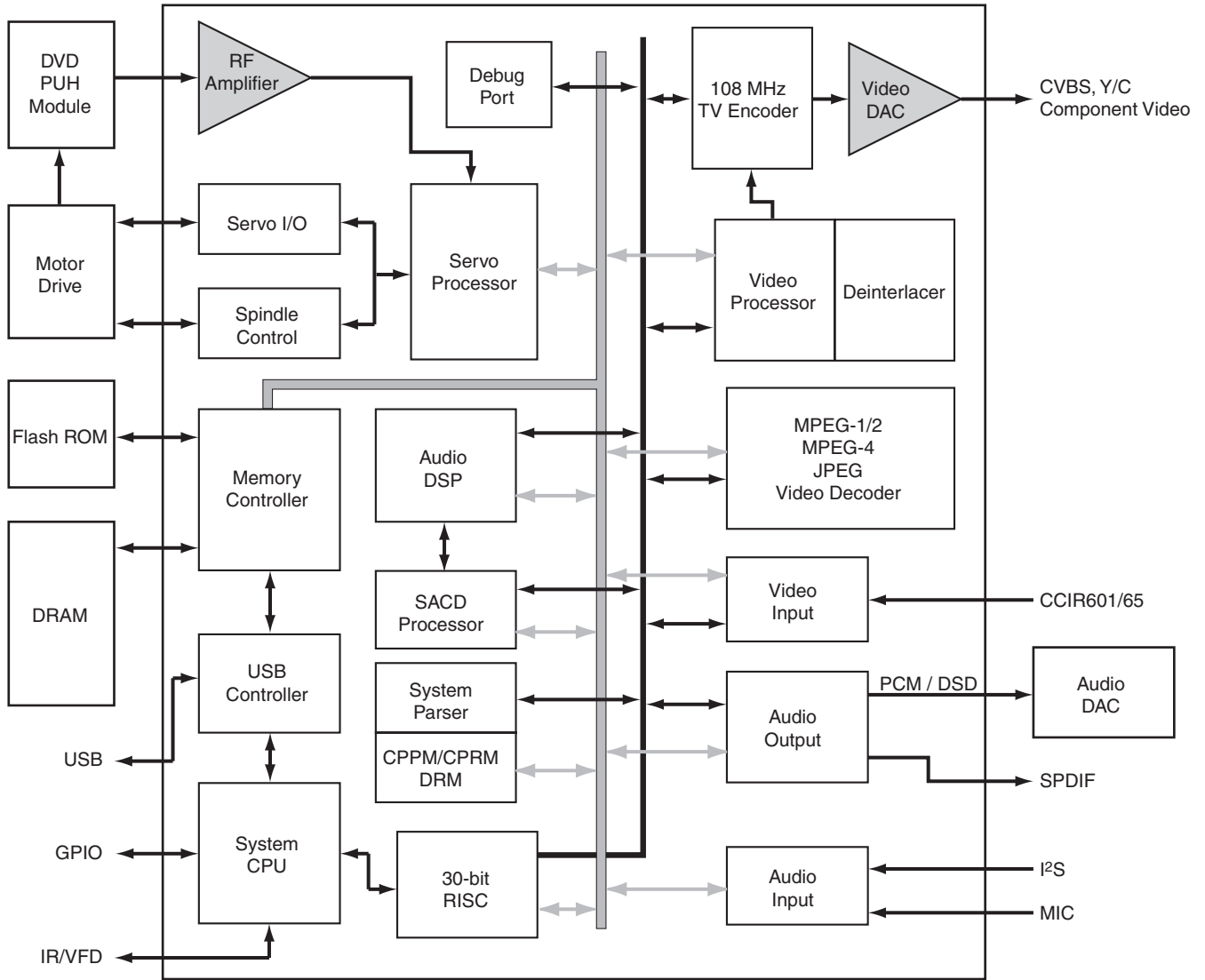

## IC BLOCK DIAGRAM/TERMINAL DESCRIPTIONS

### MT1389EE-L1 (DVDM ASSY : IC201)

DVD IC-3

No.	Name	Alt.	I/O	Function
226	RFGND18		Ground	Analog ground
227	RFVDD18		Power	Analog power 1.8V
250	CEQP		Analog output	EQ offset loop capacitance
251	CEQN		Analog output	EQ offset loop capacitance
252	OSP		Analog output	RF Offset cancellation capacitor connecting
253	OSN		Analog output	RF Offset cancellation capacitor connecting
254	RFGC		Analog output	RF AGC loop capacitor connecting for DVD-ROM
255	IREF		Analog Input	Current reference input. It generates reference current for RF path. Connect an external 15K resistor to this pin and AVSS.
256	AVDD3		Power	Analog power 3.3V
1	AGND		Ground	Analog ground
2	DVDA		Analog Input	AC coupled input path A
3	DVDB		Analog Input	AC coupled input path B
4	DVDC		Analog Input	AC coupled input path C
5	DVDD		Analog Input	AC coupled input path D
6	DVDRFIP		Analog Input	AC coupled DVD RF signal input RFIP
7	DVDRFIN		Analog Input	AC coupled DVD RF signal input RFIN
8	MA		Analog Input	DC coupled main-beam RF signal input A
9	MB		Analog Input	DC coupled main-beam RF signal input B
10	MC		Analog Input	DC coupled main-beam RF signal input C
11	MD		Analog Input	DC coupled main-beam RF signal input D
12	SA		Analog Input	DC coupled sub-beam RF signal input A
13	SB		Analog Input	DC coupled sub-beam RF signal input B
14	SC		Analog Input	DC coupled sub-beam RF signal input C
15	SD		Analog Input	DC coupled sub-beam RF signal input D
16	CDFON		Analog Input	CD focusing error negative input
17	CDFOP		Analog Input	CD focusing error positive input
18	TNI		Analog Input	3 beam satellite PD signal negative input
19	TPI		Analog Input	3 beam satellite PD signal positive input

#### ■ ALPC (4)

No.	Name	Alt.	I/O	Function
20	MDI1		Analog Input	Laser power monitor input
21	MDI2		Analog Input	Laser power monitor input
22	LDO2		Analog Output	Laser driver output
23	LDO1		Analog Output	Laser driver output

#### ■ ADC for SACD (5)

No.	Name	Alt.	I/O	Function
239	ADCVDD3		Power	Analog 3.3V Power for ADC
240	S_VCM		Analog Inout	SACD- Common mode reference
241	ADCVSS		Ground	Analog ground for ADC
242	S_VREFP		Analog Inout	SACD- TOP Reference
243	S_VREFN		Analog Inout	SACD- Bottom Reference

#### ■ Reference Voltage (3)

No.	Name	Alt.	I/O	Function
28	V2REFO		Analog output	Reference voltage 2.8V
29	V20		Analog output	Reference voltage 2.0V
30	VREFO		Analog output	Reference voltage 1.4V

## IC BLOCK DIAGRAM/TERMINAL DESCRIPTIONS

### MT1389EE-L1 (DVDM ASSY : IC201)

DVD IC-4

#### Analog Monitor Output (7)

No.	Name	Alt.	I/O	Function
24	SVDD3		Power	Analog power 3.3V
25	CSO	RFOP	Analog output	Central servo Positive main beam summing output
26	RFLVL	RFON	Analog output	RFRP low pass, or Negative main beam summing output
27	SGND		Ground	Analog ground
31	FEO		Analog output	Focus error monitor output
32	TEO		Analog output	Tracking error monitor output
33	TEZISLV		Analog output	TE Slicing Level

#### Analog Servo Interface (6)

No.	Name	Alt.	I/O	Function
244	RFVDD3		Power	Analog Power
245	RFRPDC		Analog output	RF ripple detect output
246	RFRPAC		Analog Input	RF ripple detect input(through AC-coupling)
247	HRFZC		Analog Input	High frequency RF ripple zero crossing
248	CRTPLP		Analog output	Defect level filter capacitor connecting
249	RFGND		Ground	Analog Ground

#### RF Data PLL Interface (9)

No.	Name	Alt.	I/O	Function
230	JITFO		Analog output	The output terminal of RF jitter meter.
231	JITFN		Analog Input	The input terminal of RF jitter meter.
232	PLLVSS		Ground	Ground pin for data PLL and related analog circuitry.
233	IDACEXP		Analog output	Data PLL DAC Low-pass filter
234	PLLVDD3		Power	Power pin for data PLL and related analog circuitry.
235	LPFON		Analog Output	The negative output of loop filter amplifier
236	LPFIP		Analog Input	The positive input terminal of loop filter amplifier.
237	LPFIN		Analog Input	The negative input terminal of loop filter amplifier.
238	LPFOP		Analog Output	The positive output of loop filter amplifier

#### Motor and Actuator Driver Interface (10)

No.	Name	Alt.	I/O	Function
34	OP_OUT		Analog output	Op amp output.
35	OP_INN		Analog input	Op amp negative input
36	OP_INP		Analog input	Op amp positive input
37	DMO		Analog Output	Disk motor control output. PWM output.
38	FMO		Analog Output	Feed motor control. PWM output.
39	TROPENPWM		Analog Output	Tray PWM output / Tray open output.
40	PWMOUT1	V_ADIN9	Analog Output	1st General PWM output, or Version AD input 9
41	TRO		Analog Output	Tracking servo output. PDM output of tracking servo compensator.
42	FOO		Analog Output	Focus servo output. PDM output of focus servo compensator
47	FG (Digital pin)	V_ADIN8	LVTTTL 3.3V Input, Schmitt Input, pull-up , with analog input path for V_ADIN8	Motor Hall sensor input, or Version AD input 8



## IC BLOCK DIAGRAM/TERMINAL DESCRIPTIONS

### MT1389EE-L1 (DVDM ASSY : IC201)

DVD IC-5

#### General Power / Ground (32)

No.	Name	Alt.	I/O	Function
52, 97, 122, 152, 173, 221	DVDD18		Power	1.8V power pin for internal digital circuitry
85, 116, 144, 163, 216	DVSS		Ground	1.8V Ground pin for internal digital circuitry
73, 80, 108, 127, 141, 155, 167, 182, 212	DVDD3		Power	3.3V power pin for internal digital circuitry
62, 94, 119, 134, 148, 161, 175, 223	DVSS		Ground	3.3V Ground pin for internal digital circuitry
204	DVDD3		Power	3.3V power pin Video DAC digital circuitry only
63	APLLCAP		Analog Inout	APLL External Capacitance connection
64	APLLVSS		Ground	Ground pin for audio clock circuitry
65	APLLVDD3		Power	3.3V Power pin for audio clock circuitry

#### Micro Controller and Flash Interface (48)

No.	Name	Alt.	I/O	Function
59	HIGHA0		Inout, 2-16MA, SR, PU	Microcontroller address 8
75	HIGHA1		Inout, 2-16MA, SR, PU	Microcontroller address 9
74	HIGHA2		Inout, 2-16MA, SR, PU	Microcontroller address 10
72	HIGHA3		Inout, 2-16MA, SR, PU	Microcontroller address 11
71	HIGHA4		Inout, 2-16MA, SR, PU	Microcontroller address 12
70	HIGHA5		Inout, 2-16MA, SR, PU	Microcontroller address 13
69	HIGHA6		Inout, 2-16MA, SR, PU	Microcontroller address 14
68	HIGHA7		Inout, 2-16MA, SR, PU	Microcontroller address 15
91	AD7		Inout, 2-16MA, SR	Microcontroller address/data 7
88	AD6		Inout, 2-16MA, SR	Microcontroller address/data 6
87	AD5		Inout, 2-16MA, SR	Microcontroller address/data 5
86	AD4		Inout, 2-16MA, SR	Microcontroller address/data 4
84	AD3		Inout, 2-16MA, SR	Microcontroller address/data 3
83	AD2		Inout, 2-16MA, SR	Microcontroller address/data 2
82	AD1		Inout, 2-16MA, SR	Microcontroller address/data 1
81	AD0		Inout, 2-16MA, SR	Microcontroller address/data 0
93	IOA0		Inout, 2-16MA, SR, PU	Microcontroller address 0 / IO
78	IOA1		Inout, 2-16MA, SR, PU	Microcontroller address 1 / IO
53	IOA2		Inout, 2-16MA, SR, PU	Microcontroller address 2 / IO
54	IOA3		Inout, 2-16MA, SR, PU	Microcontroller address 3 / IO
55	IOA4		Inout, 2-16MA, SR, PU	Microcontroller address 4 / IO
56	IOA5		Inout, 2-16MA, SR, PU	Microcontroller address 5 / IO
57	IOA6		Inout, 2-16MA, SR, PU	Microcontroller address 6 / IO
58	IOA7		Inout, 2-16MA, SR, PU	Microcontroller address 7 / IO
67	A16		Output, 2-16MA, SR	Flash address 16
92	A17		Output, 2-16MA, SR	Flash address 17
60	IOA18		Inout, 2-16MA, SR, SMT	Flash address 18 / IO
61	IOA19		Inout, 2-16MA, SR, SMT	Flash address 19 / IO
76	IOA20		Inout, 2-16MA, SR, SMT	Flash address 20 / IO
89	IOA21	V_ADINO	Inout, 2-16MA, SR, SMT	Flash address 21 / IO While External FLASH size <= 2MB: Version AD input port 0, or GPIO

## IC BLOCK DIAGRAM/TERMINAL DESCRIPTIONS

### MT1389EE-L1 (DVDM ASSY : IC201)

DVD IC-6

No.	Name	Alt.	I/O	Function
90	ALE		Inout, 2-16MA, SR, PU, SMT	Microcontroller address latch enable
79	IOOE#		Inout, 2-16MA, SR, SMT	Flash output enable, active low / IO
66	IOWR#		Inout, 2-16MA, SR, SMT	Flash write enable, active low / IO
77	IOCS#		Inout, 2-16MA, SR, PU, SMT	Flash chip select, active low / IO
95	UWR#		Inout, 2-16MA, SR, PU, SMT	Microcontroller write strobe, active low
96	URD#		Inout, 2-16MA, SR, PU, SMT	Microcontroller read strobe, active low
98	UP1_2		Inout, 4MA, SR, PU, SMT	Microcontroller port 1-2
99	UP1_3		Inout, 4MA, SR, PU, SMT	Microcontroller port 1-3
100	UP1_4		Inout, 4MA, SR, PU, SMT	Microcontroller port 1-4
101	UP1_5		Inout, 4MA, SR, PU, SMT	Microcontroller port 1-5
102	UP1_6	SCL	Inout, 4MA, SR, PU, SMT	Microcontroller port 1-6 I <sup>2</sup> C clock pin
103	UP1_7	SDA	Inout, 4MA, SR, PU, SMT	Microcontroller port 1-7 I <sup>2</sup> C data pin
104	UP3_0	RXD	Inout, 4MA, SR, PU, SMT	Microcontroller port 3-0 8032 RS232 RXD
105	UP3_1	TXD	Inout, 4MA, SR, PU, SMT	Microcontroller port 3-1 8032 RS232 TXD
106	UP3_4	RXD SCL	Inout, 4MA, SR, PU, SMT	Microcontroller port 3-4 Hardwired RD232 RXD I <sup>2</sup> C clock pin
107	UP3_5	TXD SDA	Inout, 4MA, SR, PU, SMT	Microcontroller port 3-5 Hardwired RD232 TXD I <sup>2</sup> C data pin
111	IR		Input, SMT	IR control signal input
112	INT0#		Inout, 2-16MA, SR, PU, SMT	Microcontroller external interrupt 0, active low

## IC BLOCK DIAGRAM/TERMINAL DESCRIPTIONS

MT1389EE-L1 (DVDM ASSY : IC201) DVD IC-7

### Audio Interface (14)

No.	Name	Alt.	I/O	Function
208	SPMCLK	SCLK0	Inout	Audio DAC master clock of SPDIF input While SPDIF input is not used: Serial interface port 0 clock pin GPIO
209	SPDATA	SDIN0	Inout	Audio data of SPDIF input While SPDIF input is not used: Serial interface port 0 data-in GPIO
210	SPLRCK	SDO0	Inout	Audio left/right channel clock of SPDIF input While SPDIF input is not used: Serial interface port 0 data-out GPIO
211	SPBCK	SDCS0 ASDATA5	Inout	Audio bit clock of SPDIF input While SPDIF input is not used: Serial interface port 0 chip select Audio serial data 5 part 1 : DSD data sub-woofer channel or Microphone output GPIO
213	ALRCK		Inout 4MA, PD, SMT	Audio left/right channel clock Trap value in power-on reset: 1 : use external 373 0 : use internal 373
214	ABCK	Fs64	Output 4MA	Audio bit clock Phase de-modulation
215	ACLK		Inout, 4MA	Audio DAC master clock
217	ASDATA0		Inout, 4MA, PD SMT	Audio serial data 0 (Front-Left/Front-Right) DSD data left channel Trap value in power-on reset : 1 : manufactory test mode 0 : normal operation
218	ASDATA1		Inout, 4MA, PD SMT	Audio serial data 1 (Left-Surround/Right-Surround) DSD data right channel Trap value in power-on reset : 1 : manufactory test mode 0 : normal operation While only 2 channels output: GPIO
219	ASDATA2		Inout, 4MA, PD SMT	Audio serial data 2 (Center/LFE) DSD data left surround channel Trap value in power-on reset : 1 : manufactory test mode 0 : normal operation While only 2 channels output: GPIO
220	ASDATA3		Inout, 4MA, PD SMT	Audio serial data 3 (Center-back/ Center-left-back/Center-right-back, in 6.1 or 7.1 mode) DSD data right surround channel Trap value in power-on reset : 1 : manufactory test mode 0 : normal operation While only 2 channels output: GPIO
222	ASDATA4	INT1#	Inout, 4MA, PD SMT	Audio serial data 4 (Down-mixed Left/Right) DSD data center channel Trap value in power-on reset : 1 : manufactory test mode 0 : normal operation While only 2 channels output: Microcontroller external interrupt 1 GPIO
224	MC_DATA	INT2#	Inout	Microphone serial input While not support Microphone: Microcontroller external interrupt 2 GPIO
225	SPDIF		Output, 2-16MA, SR : ON/OFF	SPDIF output

## IC BLOCK DIAGRAM/TERMINAL DESCRIPTIONS

### MT1389EE-L1 (DVDM ASSY : IC201)

DVD IC-8

#### Video Interface (18)

No.	Name	Alt.	I/O	Function
189	DACVDDC		Power	3.3V power pin for VIDEO DAC circuitry
190	VREF		Analog	Bandgap reference voltage
191	FS		Analog	Full scale adjustment
192	YUV0	CIN	Output 4MA, SR	Video data output bit 0 Compensation capacitor
193	DACVSSC		Ground	Ground pin for VIDEO DAC circuitry
194	YUV1	Y	Output 4MA, SR	Video data output bit 1 Analog Y output
195	DACVddb		Power	3.3V power pin for VIDEO DAC circuitry
196	YUV2	C	Output 4MA, SR	Video data output bit 2 Analog chroma output
197	DACVSSB		Ground	Ground pin for VIDEO DAC circuitry
198	YUV3	CVBS	Output 4MA, SR	Video data output bit 3 Analog composite output
199	DACVDDA		Power	3.3V power pin for VIDEO DAC circuitry
200	YUV4	Y/G	Output 4MA, SR	Video data output bit 4 Green or Y
201	DACVSSA		Ground	Ground pin for VIDEO DAC circuitry
202	YUV5	B/Cb/Pb	Output 4MA, SR	Video data output bit 5 Blue or CB
203	YUV6	R/Cr/Pr	Output 4MA, SR	Video data output bit 6 Red or CR
205	VSYN	V_ADIN1	Inout 4MA, SR SMT	Vertical sync input/output While no External TV-encoder: Vertical sync for video-input Version AD input port 1 GPIO
206	YUV7	INT3# ASDATA5	Inout 4MA, SR SMT	Video data output bit 7 While no External TV-encoder: Microcontroller external interrupt 3 Audio serial data 5 part II : DSD data sub-woofer channel or Microphone output GPIO
207	HSYN	INT4# V_ADIN2	Inout 4MA, SR SMT	Horizontal sync input/output While no External TV-encoder: Horizontal sync for video-input Microcontroller external interrupt 4 Version AD input port 2 GPIO

#### ■ MISC (8)

No.	Name	Alt.	I/O	Function
43	USB_VSS		USB Ground	USB ground pin
44	USBP		Analog Inout	USB port DPLUS analog pin
45	USBM		Analog Inout	USB port DMINUS analog pin
46	USB_VDD3		USB Power	USB Power pin 3.3V
110	PRST#		Input PU, SMT	Power on reset input, active low
109	ICE		Input PD, SMT	Microcontroller ICE mode enable
228	XTALO		Output	27M crystal out
229	XTALI		Input	27M crystal in

## IC BLOCK DIAGRAM/TERMINAL DESCRIPTIONS

MT1389EE-L1 (DVDM ASSY : IC201) DVD IC-9

DRAM Interface (63)(sorted by position)

No.	Name	Alt.	I/O	Function
188	RD16	LLC_CLK SMPTE_C[0]	Inout Pull-Down	DRAM data 16 While using 16-bits wide DRAM: Line Locked Clock input/output Digital Video output C bit 0 GPIO
187	RD17	YUVIN0 SMPTE_C[1]	Inout Pull-Down	DRAM data 17 While using 16-bits wide DRAM: Video input data 0 Digital Video output C bit 1 GPIO
186	RD18	YUVIN1 SMPTE_C[2]	Inout Pull-Down	DRAM data 18 While using 16-bits wide DRAM: Video input data 1 Digital Video output C bit 2 GPIO
185	RD19	YUVIN2 SMPTE_C[3]	Inout Pull-Down	DRAM data 19 While using 16-bits wide DRAM: Video input data 2 Digital Video output C bit 3 GPIO
184	RD20	YUVIN3 SMPTE_C[4]	Inout Pull-Down	DRAM data 20 While using 16-bits wide DRAM: Video input data 3 Digital Video output C bit 4 GPIO
183	RD21	YUVIN4 SMPTE_C[5]	Inout Pull-Down	DRAM data 21 While using 16-bits wide DRAM: Video input data 4 Digital Video output C bit 5 GPIO
181	RD22	YUVIN5 SMPTE_C[6]	Inout Pull-Down	DRAM data 22 While using 16-bits wide DRAM: Video input data 5 Digital Video output C bit 6 GPIO
180	RD23	YUVIN6 SMPTE_C[7]	Inout Pull-Down	DRAM data 23 While using 16-bits wide DRAM: Video input data 6 Digital Video output C bit 7 GPIO
179	DQM2	YUVIN7	Inout Pull-Up	Data Mask 2 While using 16-bits wide DRAM: Video input data 7 GPIO
178	DQM3	INT6# SMPTE_CLK USB_CLK	Inout Pull-Up	Data Mask 3 While using 16-bits wide DRAM: Microcontroller external interrupt 6 Digital Video output Clock USB port CLK input (48MHz) part II GPIO
177	RD24	SDIN1 MS_BS SMPTE_Y[0]	Inout Non-pull	DRAM data 24 While using 16-bits wide DRAM: Serial interface port 1 data-in MS Card BS pin part II Digital Video output Y bit 0 GPIO
176	RD25	SDO1 MS_SDIO SMPTE_Y[1]	Inout Non-pull	DRAM data 25 While using 16-bits wide DRAM: Serial interface port 1 data-out MS Card SDIO pin part II Digital Video output Y bit 1 GPIO

## IC BLOCK DIAGRAM/TERMINAL DESCRIPTIONS

MT1389EE-L1 (DVDM ASSY : IC201) DVD IC-10

No.	Name	Alt.	I/O	Function
174	RD26	SDCS1 MSCLK SMPTE_Y[2]	Inout Non-pull	DRAM data 26 While using 16-bits wide DRAM: Serial interface port 1 chip select Memory Stick Clock part II Digital Video output Y bit 2 GPIO
172	RD27	SCLK2 SDCLK SMPTE_Y[3]	Inout Non-pull	DRAM data 27 While using 16-bits wide DRAM: Serial interface port 2 clock pin Security Disk Clock part II Digital Video output Y bit 3 GPIO
171	RD28	SDIN2 SD_CMD SMPTE_Y[4]	Inout Non-pull	DRAM data 28 While using 16-bits wide DRAM: Serial interface port 2 data-in SD Card CMD pin part II Digital Video output Y bit 4 GPIO
170	RD29	SDO2 SD_DAT SMPTE_Y[5]	Inout Non-pull	DRAM data 29 While using 16-bits wide DRAM: Serial interface port 2 data-out SD Card Data pin part II Digital Video output Y bit 5 GPIO
169	RD30	SDCS2 SMPTE_Y[6]	Inout Pull-Up	DRAM data 30 While using 16-bits wide DRAM: Serial interface port 2 chip select Digital Video output Y bit 6 GPIO
168	RD31	INT5# ASDATA5 SMPTE_Y[7]	Inout Pull-Up	DRAM data 31 While using 16-bits wide DRAM: Microcontroller external interrupt 5 Audio serial data 5 part III : DSD data sub-woofer channel or Microphone output Digital Video output Y bit 7 GPIO
166	RA4		Inout	DRAM address 4
165	RA5		Inout	DRAM address 5
164	RA6		Inout	DRAM address 6
162	RA7		Inout	DRAM address 7
160	RA8		Inout	DRAM address 8
159	RA9		Inout	DRAM address 9
158	RA11	GPIO	Inout Pull-Down	DRAM address bit 11 While using DRAM size <=4MB: GPIO
157	CKE		output	DRAM clock enable
156	RCLK		Inout	DRAM clock
154	RCLKB	USB_CLK	Inout	DRAM clock invert While not using DDR: I) USB port CLK input (48MHz) part I
153	RVREF	V_ADIN3	Analog Inout	Reference voltage for DDR DRAM While not using DDR : Version AD input port 3
151	RA3		Inout	DRAM address 3
150	RA2		Inout	DRAM address 2
149	RA1		Inout	DRAM address 1
147	RA0		Inout	DRAM address 0
146	RA10		Inout	DRAM address 10
145	BA1		Inout	DRAM bank address 1
143	BA0		Inout	DRAM bank address 0

## IC BLOCK DIAGRAM/TERMINAL DESCRIPTIONS

MT1389EE-L1 (DVDM ASSY : IC201) DVD IC-11

No.	Name	Alt.	I/O	Function
142	RCS#		output	DRAM chip select, active low
140	RAS#		output	DRAM row address strobe, active low
139	CAS#		output	DRAM column address strobe, active low
138	RWE#		output	DRAM Write enable, active low
137	DQM1		Inout	Data mask 1
136	DQS1	INT7# MS_BS	Inout	Data strobe 1 for DDR DRAM While not using DDR: Microcontroller external interrupt 7 MS Card BS pin part I GPIO
135	RD8		Inout	DRAM data 8
133	RD9		Inout	DRAM data 9
132	RD10		Inout	DRAM data 10
131	RD11		Inout	DRAM data 11
130	RD12		Inout	DRAM data 12
129	RD13		Inout	DRAM data 13
128	RD14		Inout	DRAM data 14
126	RD15		Inout	DRAM data 15
125	RD0		Inout	DRAM data 0
124	RD1		Inout	DRAM data 1
123	RD2		Inout	DRAM data 2
121	RD3		Inout	DRAM data 3
120	RD4		Inout	DRAM data 4
118	RD5		Inout	DRAM data 5
117	RD6		Inout	DRAM data 6
115	RD7		Inout	DRAM data 7
114	DQS0	SCLK1 MS_SDIO	Inout	Data strobe 0 for DDR DRAM While not using DDR: Serial interface port 1 clock pin MS Card SDIO pin part I GPIO
113	DQM0		Inout	Data mask 0

### JTAG Interface (4)

No.	Name	Alt.	I/O	Function
48	TDI	SDO3 V_ADIN4 SD_DAT	Inout	JTAG data in While not using Boundary Scan: Serial interface port 3 data-out Version AD input port 4 SD Card Data pin part I GPIO
49	TMS	SDIN3 V_ADIN5 SD_CMD	Inout	While not using Boundary Scan: Serial interface port 3 data-in Version AD input port 5 SD Card CMD pin part I GPIO
50	TCK	SCLK3 V_ADIN6 SDCLK	Inout	JTAG clock While not using Boundary Scan: Serial interface port 3 clock pin Version AD input port 6 Security Disk Clock part I GPIO
51	TDO	SDCS3 V_ADIN7 MSCLK	Inout	JTAG data out While not using Boundary Scan: Serial interface port 3 chip-select Version AD input port 7 Memory Stick Clock part I GPIO

# FL TUBE VIEW

Q702: HNV-13SS15T

## GRID ASSIGNMENT

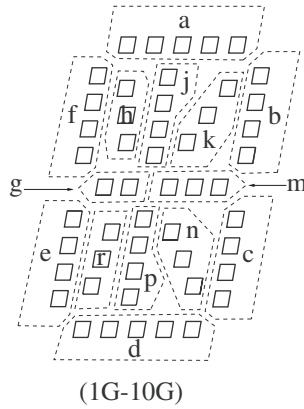
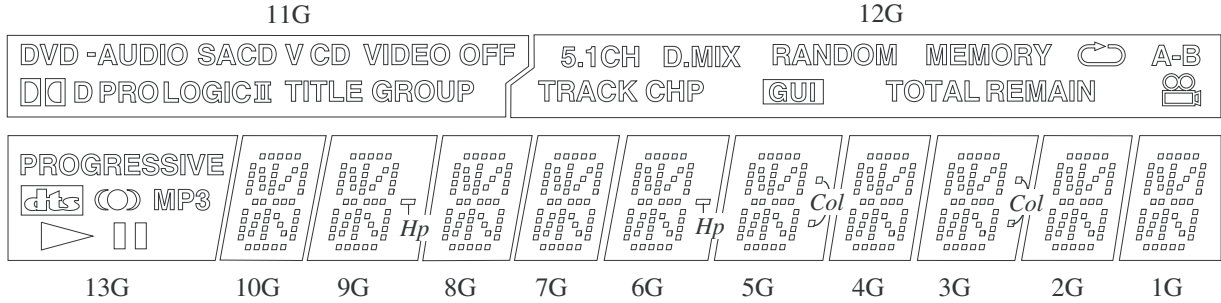

## ANODE CONNECTION

	1G	2G	3G	4G	5G	6G	7G	8G	9G	10G	11G	12G	13G
P1	a	a	a	a	a	a	a	a	a	a	GROUP		-
P2	h	h	h	h	h	h	h	h	h	h			-
P3	l	j	j	j	j	j	j	j	j	j	PRO LOGIC		-
P4	k	k	k	k	k	k	k	k	k	k	D	TRACK	-
P5	b	b	b	b	b	b	b	b	b	b			-
P6	f	f	f	f	f	f	f	f	f	f		5.1CH	-
P7	m	m	m	m	m	m	m	m	m	m	V	-B	-
P8	g	g	g	g	g	g	g	g	g	g		A	-
P9	c	c	c	c	c	c	c	c	c	c		GUI	-
P10	e	e	e	e	e	e	e	e	e	e			
P11	r	r	e	r	r	r	r	r	r	r	II		
P12	p	p	p	p	p	p	p	p	p	p			PROGRESSIVE
P13	n	n	n	n	n	n	n	n	n	n	-	D.MIX	MP3
P14	d	d	d	d	d	d	d	d	d	d	-	-	
P15	-	-	col	-	col	Hp	-	-	Hp	-	-	-	



## MICROPROCESSOR TERMINAL DESCRIPTION-1

### Q701 : MPD780232GC-707

No.	PIN NAME	SIGNAL	I/O	DESCRIPTION
1	VDD1	VDD1	-	Power supply port
2	VSS1	VSS1	-	Ground port
3	X1	X1	-	Connect to clock oscillator of main micro processor
4	X2	X2	-	Connect to clock oscillator of main micro processor
5	IC	IC	I	Connect to VSS1
6	~RESET	~RESET	I	System reset input port
7	P27/~SCK1	XSCK	I	Clock output port for write the flash ROM
8	P26/SI1	XSI	I	Data input port for write the flash ROM
9	P25/SO1	XSO	O	Data output port for write the flash ROM
10	P24/BUSY	XRDY	O	XRDY output port
11	P23	DVDPOW	O	Power ON/OFF control output port to system controller.. Active "H": Power is ON
12	P22	XRESET	O	System reset control port.
13	P21/SO3	XACK	I	ACK input port.
14	P20/~SCK3	NOT USED(GND)	I	Not used. To connect to GND.
15	P00/INTP0	~REMO	I	Remote control signal input port. Active "L": Remote control mode
16	P01/INTP1	~IRIN	I	IR remote control input port. Not used.
17	P02/TI	NOT USED(GND)	O	Not used. To connect to GND.
18	AVSS	AVSS	-	Ground port of A/D converter.
19	ANI3	DEST	I	Destination setting port.
20	ANI2	K2	I	Key input port.
21	ANI1	K1	I	Key input port.
22	ANI0	K0	I	Key input port.
23	VSS0	VSS0	-	GNNG port.
24	AVDD	AVDD	-	Reference analog power supply port. = VDD1
25	VDD0	VDD0	-	Power supply port.
26	P64/FIP52	MODEL	I	Select a model port. L= DV-SP502
27	P63/FIP51	MS0_0	I	Model select input port.
28	P62/FIP50	MS0_1	I	Model select input port.
29	P61/FIP49	MS0_2	I	Model select input port.
30	P60/FIP48	Region Auto	I	Regional code setting port. L= Automatically.
31	P57/FIP47	FLON_OFF	O	FL filament control output port.
32	P56/FIP46	STBY_LED	O	Standby LED control output port.
33	P55/FIP45	SYSIN	I	System signal bus input port.
34	P54/FIP44	SYSOUT	O	System signal bus output port.
35	P53/FIP43	R232REQ	I	REQ signal input port from RS232 microprocessor.
36	P52/FIP42	R232BUSY	I	BUSY signal input port from RS232 microprocessor.
37	P51/FIP41	R232SCK	O	SCK signal output port from RS232 microprocessor.
38	P50/FIP40	R232SI	I	SI signal input port from RS232 microprocessor.
39	P47/FIP39	R232SO	O	SO signal output port from RS232 microprocessor.
40	P46/FIP38	R232RST	O	RSTsignal output port from RS232 microprocessor.
41	P45/FIP37	NOT USED(OPEN)	O	Not used. Open port.
42	P44/FIP36	NOT USED(OPEN)	O	Not used. Open port.
43	P43/FIP35	NOT USED(OPEN)	O	Not used. Open port.
44	P42/FIP34	NOT USED(OPEN)	O	Not used. Open port.
45	P41/FIP33	NOT USED(OPEN)	O	Not used. Open port.

## MICROPROCESSOR TERMINAL DESCRIPTION-2

Q701 : MPD780232GC-707

No.	PIN NAME	SIGNAL	I/O	DESCRIPTION
46	P40/FIP32	NOT USED(OPEN)	O	Not used. Open port.
47	P37/FIP31	NOT USED(OPEN)	O	Not used. Open port.
48	P36/FIP30	P15	O	Segment (P15) control output port for FL.
49	P35/FIP29	P14	O	Segment (P14) control output port for FL.
50	P34/FIP28	P13	O	Segment (P13) control output port for FL.
51	P33/FIP27	P12	O	Segment (P12) control output port for FL.
52	P32/FIP26	P11	O	Segment (P11) control output port for FL.
53	P31/FIP25	P10	O	Segment (P10) control output port for FL.
54	P30/FIP24	P9	O	Segment (P9) control output port for FL.
55	FIP23	P8	O	Segment (P8) control output port for FL.
56	FIP22	P7	O	Segment (P7) control output port for FL.
57	FIP21	P6	O	Segment (P6) control output port for FL.
58	FIP20	P5	O	Segment (P5) control output port for FL.
59	VDD2	VDD2		Power supply for FL
60	VLOAD	VLOAD		Connect to a pull down resistor.
61	FIP19	P4	O	Segment (P4) control output port for FL.
62	FIP18	P3	O	Segment (P3) control output port for FL.
63	FIP17	P2	O	Segment (P2) control output port for FL.
64	FIP16	P1	O	Segment (P1) control output port for FL.
65	FIP15	NC(OPEN)	O	Not used. Open port.
66	FIP14	NC(OPEN)	O	Not used. Open port.
67	FIP13	NC(OPEN)	O	Not used. Open port.
68	FIP12	13G	O	Grid (13G) control output port.
69	FIP11	12G	O	Grid (12G) control output port.
70	FIP10	11G	O	Grid (11G) control output port.
71	FIP9	10G	O	Grid (10G) control output port.
72	FIP8	9G	O	Grid (9G) control output port.
73	FIP7	8G	O	Grid (8G) control output port.
74	FIP6	7G	O	Grid (7G) control output port.
75	FIP5	6G	O	Grid (6G) control output port.
76	FIP4	5G	O	Grid (5G) control output port.
77	FIP3	4G	O	Grid (4G) control output port.
78	FIP2	3G	O	Grid (3G) control output port.
79	FIP1	2G	O	Grid (2G) control output port.
80	FIP0	1G	O	Grid (1G) control output port.

# FIRMWARE DOWN LOADING

## When exchanged the DVD main board assy

### • Confirm the Regional code and Firmware version.

1. Connect the TV monitor to the DPS-6.5.
2. Turn ON the standby switch ON. (No Disc)
3. Press "SET UP" key.  
Appear a HOME MENU. (Photo-1)
4. Select "Initial Settings" menu and press "ENTER".
5. Select "Options" menu, and press the "DISPLAY" button of the front panel.
6. Appear regional code and firmware ROM number.  
Confirm the regional cord and firmware version.  
When close the menu, press "RETURN" button of the unit. (Photo-2)

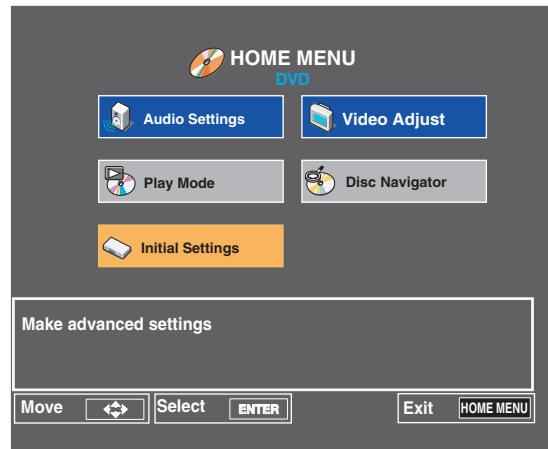

(Photo-1)

### • Download the firmware

1. Newest FW is written in CD-R with a personal computer.
2. Press "Standby" button and "Disc Tray" button ▲.
3. Set the CD-R on the Disc tray and press "Play" button.  
Waiting 2 seconds and open the tray automatically.  
DISC TRAY waits for about 2 minutes in the tray open condition.  
**Cautions: Do not close the disc tray.**  
Close the tray automatically.
4. Pull out the power cord from inlet terminal.  
And insert the power cord again.
5. Press "Standby" button .  
Confirm the regional code and firmware version at above method.

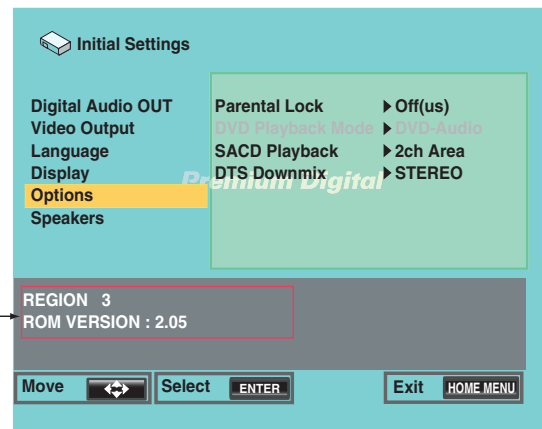

(Photo-2)

## Writing CD-R for upgrade firmware

1. Install the newest firmware data.
2. Making the folder.  
Volume label name or holder name is "Pioneer".
3. Put in a newest firmware data in the "Pioneer" folder.

Volume label or Folder name

PIONEER

FW data

Ex: B4GA2056.BIN

Ex: B4HA2056.BIN

Except <MDD>

Ex: B4GA2056.BIN

<MDD>

# ID NUMBER AND ID DATA SETTING-1

**Caution:**

For the DVD players compatible with DVD-RW, for playback of a DVD-RW disc (CPRM), it is necessary that an individual ID number and ID data are set for each player. If the ID number and ID data be not properly set in the manner described below, future operations cannot be guaranteed. The ID number is written on the paper label at the DVD mechanism of the player.

## Preparations

- Remote controller RC-484M
- ID writing disc. (0R120)
- TV monitor.

## ID Number input mode

1. Standby switch ON. (No disc condition)
2. Press "DVD" and "1" at same time, press "RETURN" key and "STEREO" key. ← **Remote controller (RC-484M)**



3. Appear (A) on the TV monitor
4. Input nine digits.
5. Press "PLAY" key.
6. Appear (B) on the monitor.
7. Press "PLAY" key. (C)
8. Inset ID Data Disc on the tray.
9. Press "Play".

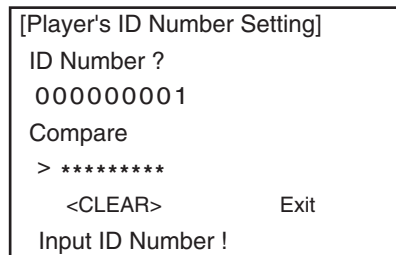

(A)

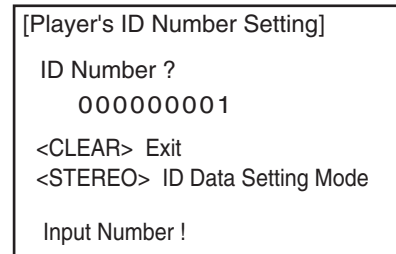

(B)

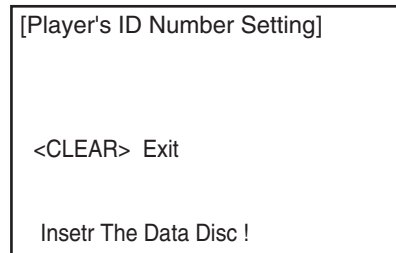

(C)

### ID NUMBER

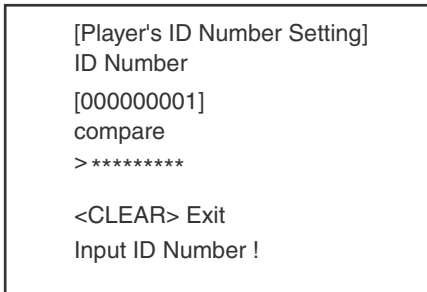

or

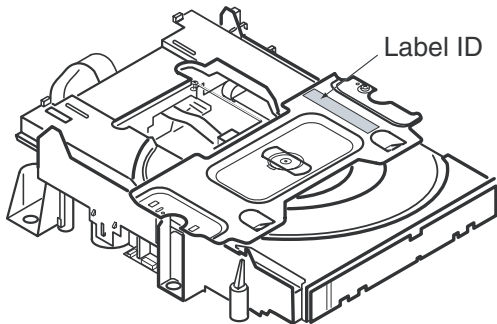

DVD Mechanism

# PACKING PROCEDURES

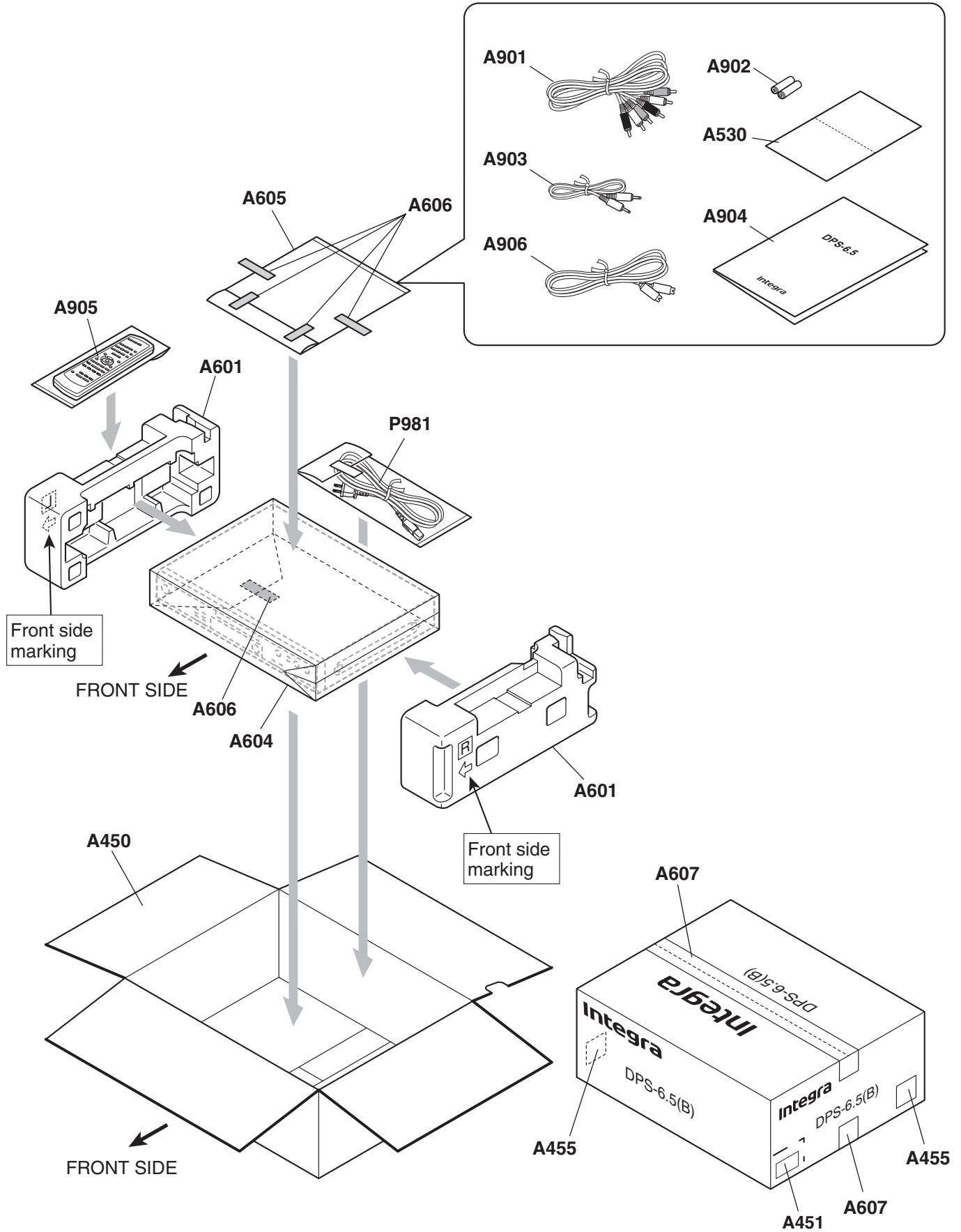

## EXPLODED VIEW PARTS LIST

NOTE : THE COMPONENTS IDENTIFIED BY THE MARK  
! ARE CRITICAL FOR RISK OF FIRE AND  
ELECTRIC SHOCK. REPLACE ONLY WITH PART  
NUMBER SPECIFIED.

## &lt;Notes&gt;

! :Safety parts

&lt;MDD&gt; :North American area

&lt;MUA&gt; :Australia area

	REF. NO.	NAME	DESCRIPTION	Q'TY	PART NO	REMARKS
EXP	A001	CHASSIS	DV-SP402E	1	27100447	
EXP	A003	LEG	LEG	4	27175316C	
EXP	A005	CUSHION	---	8	28141494	
EXP	A007	SCREW	3TTB+8B	29	838130088	
EXP	A008	IB CUSHION	W15x3t TAPE	1	28141585	MP0082:CM
EXP	A009	TAPE	TAPE(CLOTH-16U)	(1)	29110083	MP0080.18:MT
EXP	A010	BRACKET	(DG)	1	27130963A	DG PWB
EXP	A012	HOLDER	KGLS-24RT	3	27190814	PWB-CHASSIS
EXP	A013	BRACKET	(POW)	1	27130962A	POW PWB
EXP	A015	SCREW	4TTC+6C(BC)	2	830440069	
EXP	A018	TAPE	TAPE(CLOTH-8U)	(1)	29110082	:0.12:MT
EXP	A020	LABEL(DVD2)	---	1	29362648	
EXP	A025	F BRACKET	(B)	1	27111325A	
EXP	A026	KNOB	(STANDBY)	1	28325756	
EXP	A027	CLEAR PLT	---	1	28191993	
EXP	A028	B PLATE	DPS-5.4(B)	1	28133410	
EXP	A029	TAPE	---	(2)	29110161	FBRACKET
EXP	A033	SCREW	2.6TTB+8B(BC)	3	838426088	
EXP	A034	CUSHION	---	2	28141606	F BRACKET
EXP	A040	KNOB	(CRS)	1	28326078	
EXP	A051	DOOR	---	1	28148479A	
EXP	A052	PLATE	(DVD)	1	27262744	N
EXP	A055	COVER	(B)	1	28184864	
EXP	A056	SCREW	3TTB+8B(BC)	24	838430088	
EXP	A401	F PANEL	DPS6.5(B)	1	27212706	N
EXP	A403	BADGE	---	1	28135278	
EXP	A404	FACET	(S)	2	28198906	
EXP	A411	REAR PANEL	DPS6.5MDD1N	1	27123348A	<MDD> N
EXP	A411	REAR PANEL	DPS6.5MUA4P	1	27123349A	<MUA> N
EXP	A414	SCREW	4TTB+8C(BC)	2	838440089	
EXP	A415	TAPE	TAPE(CLOTH-8U)	(1)	29110082	RAR PANEL:0.09:MT
EXP	CN1	PLUG	NPLG-2P632	1	25055676	NGPS-0048
EXP	CN103	SOCKET AS	NSAS-10P1135	1	20044391030	
EXP	CN201	FFC	NCFC5-152022	1	2045152022	
EXP	CN451	FFC	NCFC6-170522	1	2046170522	
EXP	F1	FUSE	1.6A-TL/T-ST2	1	252252	! <MDD>
EXP	F1	FUSE	2.5A-TH250V	1	252310	! <MUA>
EXP	F2	FUSE LABEL	F1 1.6A125V	1	29364012	<MDD>
EXP	CP1	Protector	491.800PAR (0.8A)		252311	
EXP	P901A	CORE	NFY-25 BLACK	1	230945	
EXP	P910	WIRE TIE	BSK-1	4	260208	
EXP	S731	JOY STICK	NPS-115-S673	1	25035710	
EXP	U01	Front display PC board AS	NADIS-8416-1G	1	1H524516-1G	<MDD> N
EXP	U01	Front display PC board AS	NADIS-8416-1H	1	1H524516-1H	<MUA> N
EXP	U02	Standby LED PC board AS	NADIS-8417-1G	1	1H524517-1G	<MDD> N
EXP	U02	Standby LED PC board AS	NADIS-8417-1H	1	1H524517-1H	<MUA> N
EXP	U03	Audio/ Video output PC board AS	NAAR-8419-1G	1	1H524519-1G	<MDD> N
EXP	U03	Audio/ Video output PC board AS	NAAR-8419-1H	1	1H524519-1H	<MUA> N
EXP	U04	Inlet terminal PC board AS	NAPS-8420-1G	1	1H524520-1G	<MDD> N
EXP	U04	Inlet terminal PC board AS	NAPS-8420-1H	1	1H524520-1H	<MUA> N
EXP	U05	DVD Main board AS	DB-VPB613	1	24150062	N
EXP	U06	Power supply unit	NGPS-0047 (100-120V)	1	24150047	<MDD>
EXP	U06	Power supply unit	NGPS-0048 (100-240V)	1	24150048	<MUA>
EXP	Z101	DVD Mechanism	DB-VLD601	1	24801024	
EXP	Z102	HOLDER	(ML)	1	27191201	
EXP	Z103	HOLDER	(MR)	1	27191202	

EXP	Z104	SCREW	3SMS8W.SW+14B(BC)	4	801433	
EXP	Z106	IB CUSHION	W15x3t TAPE	1	28141585	MP0081:CM
EXP	Z107	CUSHION	(DAC)	2	28141445	

## DPS-6.5

## PRINTED CIRCUIT BOARD PARTS LIST

## &lt;Notes&gt;

<b>U01</b>	<b>FRONT DISPLAY PC BOARD(NADIS-8416-1G/1H)</b>
<b>U02</b>	<b>STANDBY LED PC BOARD(NADIS-8417-1G/1H)</b>
<b>U03</b>	<b>AUDIO/VIDEO OUTPUT PC BOARD(NAAR-8419-1G/1H)</b>
<b>U04</b>	<b>INLET TERMINAL PC BOARD(NAPS-8420-1G/1H)</b>

! :Safety parts

&lt;MDD&gt; :North American area

&lt;MUA&gt; :Australia area

	REF. NO.	NAME	DESCRIPTION	Q'TY	PART NO	REMARKS
PCB	Q501	IC	MPD4721GS	1	22241537R2	<MDD>
PCB	Q501	IC	MPD4721GS	1	22241537R2	<MUA>
PCB	Q502	IC	MPD789071MC-U11-5A1	1	22241624R2	<MDD>
PCB	Q502	IC	MPD789071MC-U11-5A1	1	22241624R2	<MUA>
PCB	Q503	IC	TC74VHCT32AFT	1	22274032GR2TO	<MDD>
PCB	Q503	IC	TC74VHCT32AFT	1	22274032GR2TO	<MUA>
PCB	Q504	IC	BA7664AFV	1	22242164R2	<MDD>
PCB	Q504	IC	BA7664AFV	1	22242164R2	<MUA>
PCB	Q505	PHT CP	ON3131	1	24120043	<MDD>
PCB	Q505	PHT CP	ON3131	1	24120043	<MUA>
PCB	Q506	TR	KRC102S	1	2216190R2	<MDD>
PCB	Q506 or	TR	RN1402	(1)	2214470R2	<MDD>
PCB	Q506 or	TR	DTC114EKA	(1)	2216250R2	<MDD>
PCB	Q506	TR	KRC102S	1	2216190R2	<MUA>
PCB	Q506 or	TR	RN1402	(1)	2214470R2	<MUA>
PCB	Q506 or	TR	DTC114EKA	(1)	2216250R2	<MUA>
PCB	Q507	TR	KRC102S	1	2216190R2	<MDD>
PCB	Q507 or	TR	RN1402	(1)	2214470R2	<MDD>
PCB	Q507 or	TR	DTC114EKA	(1)	2216250R2	<MDD>
PCB	Q507	TR	KRC102S	1	2216190R2	<MUA>
PCB	Q507 or	TR	RN1402	(1)	2214470R2	<MUA>
PCB	Q507 or	TR	DTC114EKA	(1)	2216250R2	<MUA>
PCB	Q508	IC(REGULATOR)	78M05HF(NJM/8M05D 1JA TEL)	1	222780055R2JR	<MDD>
PCB	Q508	IC(REGULATOR)	78M05HF(NJM/8M05D 1JA TEL)	1	222780055R2JR	<MUA>
PCB	Q509	TR	KRC107S	1	2216340R2	<MDD>
PCB	Q509 or	TR	RN1407	(1)	2216260R2	<MDD>
PCB	Q509 or	TR	DTC114YKA	(1)	2216470R2	<MDD>
PCB	Q509	TR	KRC107S	1	2216340R2	<MUA>
PCB	Q509 or	TR	RN1407	(1)	2216260R2	<MUA>
PCB	Q509 or	TR	DTC114YKA	(1)	2216470R2	<MUA>
PCB	Q701	IC	MPD780232GC-709-8BT	1	22242204R3	
PCB	Q702	FL TUBE	HNV-13SS15T	1	212253	
PCB	Q702A	CUSHION	t3x10x25	2	28141513	
PCB	Q704	IC	S-80127CNMC-JKM-T2	1	22241642R2	
PCB	Q706	TR	2SD655-E	1	2211705	
PCB	Q706 or	TR	2SD655-F	(1)	2211706	
PCB	Q707	REMO SENS	RPM7238-H9	1	241355	
PCB	Q708	TR	KRC107S	1	2216340R2	
PCB	Q708 or	TR	RN1407	(1)	2216260R2	
PCB	Q708 or	TR	DTC114YKA	(1)	2216470R2	
PCB	Q709	TR	KRA107S	1	2216350R2	
PCB	Q709 or	TR	RN2407	(1)	2216360R2	
PCB	Q709 or	TR	DTA114YKA	(1)	2216480R2	
PCB	Q710	TR	KRA107S	1	2216350R2	
PCB	Q710 or	TR	RN2407	(1)	2216360R2	
PCB	Q710 or	TR	DTA114YKA	(1)	2216480R2	
PCB	Q711	TR	KRC107S	1	2216340R2	
PCB	Q711 or	TR	RN1407	(1)	2216260R2	
PCB	Q711 or	TR	DTC114YKA	(1)	2216470R2	
PCB	Q714	TR	KRC107S	1	2216340R2	
PCB	Q714 or	TR	RN1407	(1)	2216260R2	

PCB	Q714 or	TR	DTC114YKA	(1)	2216470R2	
PCB	D701	C-DIODE	ISS355	1	223269R2	
PCB	D701 or	C-DIODE	ISS352	(1)	223234R2	
PCB	D704	LED	SEL2E10C	1	225374	
PCB	D721	LED	SEL4110R	1	225290	
PCB	L513	CORE	BLM41PG750SN1L	1	230950R2	<MDD>
PCB	L513	CORE	BLM41PG750SN1L	1	230950R2	<MUA>
PCB	L514	EMIFIL	BK1608LM182-T	1	230958R1	<MDD>
PCB	L514	EMIFIL	BK1608LM182-T	1	230958R1	<MUA>
PCB	L515	EMIFIL	BK1608LM182-T	1	230958R1	<MDD>
PCB	L515	EMIFIL	BK1608LM182-T	1	230958R1	<MUA>
PCB	L516	EMIFIL	BK1608LM182-T	1	230958R1	<MDD>
PCB	L516	EMIFIL	BK1608LM182-T	1	230958R1	<MUA>
PCB	L517	EMIFIL	BK1608LM182-T	1	230958R1	<MDD>
PCB	L517	EMIFIL	BK1608LM182-T	1	230958R1	<MUA>
PCB	L518	EMIFIL	BK1608LM182-T	1	230958R1	<MDD>
PCB	L518	EMIFIL	BK1608LM182-T	1	230958R1	<MUA>
PCB	L519	CORE	BLM41PG750SN1L	1	230950R2	<MDD>
PCB	L519	CORE	BLM41PG750SN1L	1	230950R2	<MUA>
PCB	X501	CERA LOCK	CST5.00MGW	1	3010242	<MDD>
PCB	X501	CERA LOCK	CST5.00MGW	1	3010242	<MUA>
PCB	X701	CERA LOCK	CST5.00MGW	1	3010242	
PCB	C501	VR C	CE04W6.3V-470M(VR)	1	394624717	<MDD>
PCB	C501	VR C	CE04W6.3V-470M(VR)	1	394624717	<MUA>
PCB	C502	VR C	CE04W6.3V-470M(VR)	1	394624717	<MDD>
PCB	C502	VR C	CE04W6.3V-470M(VR)	1	394624717	<MUA>
PCB	C503	VR C	CE04W6.3V-1000M(VR)	1	394621027	<MDD>
PCB	C503	VR C	CE04W6.3V-1000M(VR)	1	394621027	<MUA>
PCB	C504	VR C	CE04W6.3V-470M(VR)	1	394624717	<MDD>
PCB	C504	VR C	CE04W6.3V-470M(VR)	1	394624717	<MUA>
PCB	C505	VR C	CE04W6.3V-470M(VR)	1	394624717	<MDD>
PCB	C505	VR C	CE04W6.3V-470M(VR)	1	394624717	<MUA>
PCB	C506	VR C	CE04W6.3V-1000M(VR)	1	394621027	<MDD>
PCB	C506	VR C	CE04W6.3V-1000M(VR)	1	394621027	<MUA>
PCB	C507	VR C	CE04W6.3V-470M(VR)	1	394624717	<MDD>
PCB	C507	VR C	CE04W6.3V-470M(VR)	1	394624717	<MUA>
PCB	C508	C-CERA C	CK725B1C-104K1	1	332121045R1	<MDD>
PCB	C508	C-CERA C	CK725B1C-104K1	1	332121045R1	<MUA>
PCB	C509	VR C	CE04W6.3V-470M(VR)	1	394624717	<MDD>
PCB	C509	VR C	CE04W6.3V-470M(VR)	1	394624717	<MUA>
PCB	C510	C-CERA C	CK725B1C-104K1	1	332121045R1	<MDD>
PCB	C510	C-CERA C	CK725B1C-104K1	1	332121045R1	<MUA>
PCB	C511	VR C	CE04W16V-22M(VR)	1	394642207	<MDD>
PCB	C511	VR C	CE04W16V-22M(VR)	1	394642207	<MUA>
PCB	C512	VR C	CE04W6.3V-470M(VR)	1	394624717	<MDD>
PCB	C512	VR C	CE04W6.3V-470M(VR)	1	394624717	<MUA>
PCB	C514	VR C	CE04W6.3V-470M(VR)	1	394624717	<MDD>
PCB	C514	VR C	CE04W6.3V-470M(VR)	1	394624717	<MUA>
PCB	C515	C-CERA C	CK725B1C-104K1	1	332121045R1	<MDD>
PCB	C515	C-CERA C	CK725B1C-104K1	1	332121045R1	<MUA>
PCB	C516	C-CERA C	CK725F1E-104Z1	1	332161040R1	<MDD>
PCB	C516	C-CERA C	CK725F1E-104Z1	1	332161040R1	<MUA>
PCB	C517	VR C	CE04W6.3V-220M(VR)	1	394622217	<MDD>
PCB	C517	VR C	CE04W6.3V-220M(VR)	1	394622217	<MUA>
PCB	C518	C-CERA C	CK725F1E-104Z1	1	332161040R1	<MDD>
PCB	C518	C-CERA C	CK725F1E-104Z1	1	332161040R1	<MUA>
PCB	C519	C-CERA C	CK725F1E-104Z1	1	332161040R1	<MDD>
PCB	C519	C-CERA C	CK725F1E-104Z1	1	332161040R1	<MUA>
PCB	C520	C-CERA C	CK725B1E-223K1	1	332112235R1	<MDD>
PCB	C520	C-CERA C	CK725B1E-223K1	1	332112235R1	<MUA>
PCB	C521	VR C	CE04W50V-1M(VR)	1	394680107	<MDD>
PCB	C521	VR C	CE04W50V-1M(VR)	1	394680107	<MUA>
PCB	C522	VR C	CE04W50V-1M(VR)	1	394680107	<MDD>
PCB	C522	VR C	CE04W50V-1M(VR)	1	394680107	<MUA>
PCB	C523	C-CERA C	CK725F1E-104Z1	1	332161040R1	<MDD>



PCB	C523	C-CERA C	CK725F1E-104Z1	1	332161040R1	<MUA>
PCB	C524	VR C	CE04W6.3V-100M(VR)	1	394621017	<MDD>
PCB	C524	VR C	CE04W6.3V-100M(VR)	1	394621017	<MUA>
PCB	C525	VR C	CE04W50V-1M(VR)	1	394680107	<MDD>
PCB	C525	VR C	CE04W50V-1M(VR)	1	394680107	<MUA>
PCB	C526	VR C	CE04W50V-1M(VR)	1	394680107	<MDD>
PCB	C526	VR C	CE04W50V-1M(VR)	1	394680107	<MUA>
PCB	C527	C-CERA C	CK725F1E-104Z1	1	332161040R1	<MDD>
PCB	C527	C-CERA C	CK725F1E-104Z1	1	332161040R1	<MUA>
PCB	C528	VR C	CE04W6.3V-100M(VR)	1	394621017	<MDD>
PCB	C528	VR C	CE04W6.3V-100M(VR)	1	394621017	<MUA>
PCB	C529	VR C	CE04W6.3V-1000M(VR)	1	394621027	<MDD>
PCB	C529	VR C	CE04W6.3V-1000M(VR)	1	394621027	<MUA>
PCB	C530	VR C	CE04W16V-10M(VR)	1	394641007	<MDD>
PCB	C530	VR C	CE04W16V-10M(VR)	1	394641007	<MUA>
PCB	C531	C-CERA C	CK725F1E-104Z1	1	332161040R1	<MDD>
PCB	C531	C-CERA C	CK725F1E-104Z1	1	332161040R1	<MUA>
PCB	C532	VR C	CE04W6.3V-100M(VR)	1	394621017	<MDD>
PCB	C532	VR C	CE04W6.3V-100M(VR)	1	394621017	<MUA>
PCB	C533	C-CERA C	CK725F1E-104Z1	1	332161040R1	<MDD>
PCB	C533	C-CERA C	CK725F1E-104Z1	1	332161040R1	<MUA>
PCB	C534	VR C	CE04W6.3V-470M(VR)	1	394624717	<MDD>
PCB	C534	VR C	CE04W6.3V-470M(VR)	1	394624717	<MUA>
PCB	C535	C-CERA C	CK725B1C-104K1	1	332121045R1	<MDD>
PCB	C535	C-CERA C	CK725B1C-104K1	1	332121045R1	<MUA>
PCB	C701	ELECT C	CE04W6.3V-100M	1	355721019	
PCB	C702	C-CERA C	CK725F1E-104Z1	1	332161040R1	
PCB	C703	C-CERA C	CK725F1E-104Z1	1	332161040R1	
PCB	C705	ELECT C	CE04W50V-22M	1	355782209	
PCB	C706	ELECT C	CE04W6.3V-100M	1	355721019	
PCB	R501	C-CARBON R	RN72K1J-750JE	1	435037504R1	<MDD>
PCB	R501	C-CARBON R	RN72K1J-750JE	1	435037504R1	<MUA>
PCB	R502	C-CARBON R	RN72K1J-750JE	1	435037504R1	<MDD>
PCB	R502	C-CARBON R	RN72K1J-750JE	1	435037504R1	<MUA>
PCB	R503	C-CARBON R	RN72K1J-750JE	1	435037504R1	<MDD>
PCB	R503	C-CARBON R	RN72K1J-750JE	1	435037504R1	<MUA>
PCB	R504	C-CARBON R	RN72K1J-000JE	1	435030004R1	<MDD>
PCB	R504	C-CARBON R	RN72K1J-000JE	1	435030004R1	<MUA>
PCB	R505	C-CARBON R	RN72K1J-000JE	1	435030004R1	<MDD>
PCB	R505	C-CARBON R	RN72K1J-000JE	1	435030004R1	<MUA>
PCB	R506	C-CARBON R	RN72K1J-000JE	1	435030004R1	<MDD>
PCB	R506	C-CARBON R	RN72K1J-000JE	1	435030004R1	<MUA>
PCB	R507	C-CARBON R	RN72K1J-750JE	1	435037504R1	<MDD>
PCB	R507	C-CARBON R	RN72K1J-750JE	1	435037504R1	<MUA>
PCB	R508	C-CARBON R	RN72K1J-750JE	1	435037504R1	<MDD>
PCB	R508	C-CARBON R	RN72K1J-750JE	1	435037504R1	<MUA>
PCB	R509	C-CARBON R	RN72K1J-750JE	1	435037504R1	<MDD>
PCB	R509	C-CARBON R	RN72K1J-750JE	1	435037504R1	<MUA>
PCB	R510	C-CARBON R	RN72K1J-000JE	1	435030004R1	<MDD>
PCB	R510	C-CARBON R	RN72K1J-000JE	1	435030004R1	<MUA>
PCB	R511	C-CARBON R	RN72K1J-000JE	1	435030004R1	<MDD>
PCB	R511	C-CARBON R	RN72K1J-000JE	1	435030004R1	<MUA>
PCB	R512	C-CARBON R	RN72K1J-000JE	1	435030004R1	<MDD>
PCB	R512	C-CARBON R	RN72K1J-000JE	1	435030004R1	<MUA>
PCB	R513	C-CARBON R	RN72K1J-750JE	1	435037504R1	<MDD>
PCB	R513	C-CARBON R	RN72K1J-750JE	1	435037504R1	<MUA>
PCB	R514	C-CARBON R	RN72K1J-750JE	1	435037504R1	<MDD>
PCB	R514	C-CARBON R	RN72K1J-750JE	1	435037504R1	<MUA>
PCB	R515	C-CARBON R	RN72K1J-750JE	1	435037504R1	<MDD>
PCB	R515	C-CARBON R	RN72K1J-750JE	1	435037504R1	<MUA>
PCB	R516	C-CARBON R	RN72K1J-750JE	1	435037504R1	<MDD>
PCB	R516	C-CARBON R	RN72K1J-750JE	1	435037504R1	<MUA>
PCB	R517	C-CARBON R	RN72K1J-000JE	1	435030004R1	<MDD>
PCB	R517	C-CARBON R	RN72K1J-000JE	1	435030004R1	<MUA>
PCB	R518	C-CARBON R	RN72K1J-000JE	1	435030004R1	<MDD>



PCB	R551	C-CARBON R	RN72K1J-470JE	1	435034704R1	<MDD>
PCB	R551	C-CARBON R	RN72K1J-470JE	1	435034704R1	<MUA>
PCB	R552	C-CARBON R	RN72K1J-470JE	1	435034704R1	<MDD>
PCB	R552	C-CARBON R	RN72K1J-470JE	1	435034704R1	<MUA>
PCB	R553	C-CARBON R	RN72K1J-103JE	1	435031034R1	<MDD>
PCB	R553	C-CARBON R	RN72K1J-103JE	1	435031034R1	<MUA>
PCB	R556	C-CARBON R	RN72K1J-000JE	1	435030004R1	<MDD>
PCB	R556	C-CARBON R	RN72K1J-000JE	1	435030004R1	<MUA>
PCB	R557	C-CARBON R	RN72K1J-000JE	1	435030004R1	<MDD>
PCB	R557	C-CARBON R	RN72K1J-000JE	1	435030004R1	<MUA>
PCB	R701	C-CARBON R	RN72K1J-103JE	1	435031034R1	
PCB	R702	C-CARBON R	RN72K1J-000JE	1	435030004R1	
PCB	R703	C-CARBON R	RN72K1J-101JE	1	435031014R1	
PCB	R704	C-CARBON R	RN72K1J-000JE	1	435030004R1	
PCB	R705	C-CARBON R	RN72K1J-000JE	1	435030004R1	
PCB	R706	C-CARBON R	RN72K1J-000JE	1	435030004R1	
PCB	R707	C-CARBON R	RN72K1J-000JE	1	435030004R1	
PCB	R708	C-CARBON R	RN72K1J-000JE	1	435030004R1	
PCB	R709	C-CARBON R	RN72K1J-182JE	1	435031824R1	<MDD>
PCB	R709	C-CARBON R	RN72K1J-182JE	1	435031824R1	<MUA>
PCB	R710	C-CARBON R	RN72K1J-000JE	1	435030004R1	
PCB	R711	C-CARBON R	RN72K1J-105JE	1	435031054R1	
PCB	R712	C-CARBON R	RN72K1J-182JE	1	435031824R1	<MDD>
PCB	R712	C-CARBON R	RN72K1J-182JE	1	435031824R1	<MUA>
PCB	R713	C-CARBON R	RN72K1J-224JE	1	435032244R1	
PCB	R714	C-CARBON R	RN72K1J-101JE	1	435031014R1	
PCB	R715	C-CARBON R	RN72K1J-101JE	1	435031014R1	
PCB	R716	C-CARBON R	RN72K1J-182JE	1	435031824R1	<MDD>
PCB	R716	C-CARBON R	RN72K1J-182JE	1	435031824R1	<MUA>
PCB	R717	C-CARBON R	RN72K1J-332JE	1	435033324R1	<MDD>
PCB	R717	C-CARBON R	RN72K1J-332JE	1	435033324R1	<MUA>
PCB	R718	C-CARBON R	RN72K1J-332JE	1	435033324R1	<MDD>
PCB	R718	C-CARBON R	RN72K1J-332JE	1	435033324R1	<MUA>
PCB	R719	C-CARBON R	RN72K1J-103JE	1	435031034R1	
PCB	R720	C-CARBON R	RN72K1J-103JE	1	435031034R1	
PCB	R721	C-CARBON R	RN72K1J-103JE	1	435031034R1	
PCB	R722	C-CARBON R	RN72K1J-332JE	1	435033324R1	<MDD>
PCB	R722	C-CARBON R	RN72K1J-332JE	1	435033324R1	<MUA>
PCB	R723	C-CARBON R	RN72K1J-223JE	1	435032234R1	
PCB	R724	C-CARBON R	RN72K1J-470JE	1	435034704R1	<MDD>
PCB	R724	C-CARBON R	RN72K1J-470JE	1	435034704R1	<MUA>
PCB	R725	C-CARBON R	RN72K1J-470JE	1	435034704R1	<MDD>
PCB	R725	C-CARBON R	RN72K1J-470JE	1	435034704R1	<MUA>
PCB	R726	C-CARBON R	RN72K1J-470JE	1	435034704R1	<MDD>
PCB	R726	C-CARBON R	RN72K1J-470JE	1	435034704R1	<MUA>
PCB	R727	C-CARBON R	RN72K1J-000JE	1	435030004R1	
PCB	R728	C-CARBON R	RN72K1J-102JE	1	435031024R1	<MDD>
PCB	R728	C-CARBON R	RN72K1J-102JE	1	435031024R1	<MUA>
PCB	R729	C-CARBON R	RN72K1J-822JE	1	435038224R1	<MDD>
PCB	R729	C-CARBON R	RN72K1J-822JE	1	435038224R1	<MUA>
PCB	R731	C-CARBON R	RN72K1J-272JE	1	435032724R1	<MDD>
PCB	R731	C-CARBON R	RN72K1J-272JE	1	435032724R1	<MUA>
PCB	R732	C-CARBON R	RN72K1J-000JE	1	435030004R1	
PCB	R734	C-CARBON R	RN72K1J-000JE	1	435030004R1	
PCB	R736	C-CARBON R	RN72K1J-000JE	1	435030004R1	
PCB	R738	C-CARBON R	RN72K1J-183JE	1	435031834R1	<MUA>
PCB	R738	C-CARBON R	RN72K1J-472JE	1	435034724R1	<MDD>
PCB	R739	C-CARBON R	RN72K1J-333JE	1	435033334R1	<MDD>
PCB	R739	C-CARBON R	RN72K1J-563JE	1	435035634R1	<MUA>
PCB	R742	C-CARBON R	RN72K1J-000JE	1	435030004R1	
PCB	R743	C-CARBON R	RN72K1J-100JE	1	435031004R1	
PCB	R745	C-CARBON R	RN72K1J-000JE	1	435030004R1	
PCB	R746	C-CARBON R	RN72K1J-000JE	1	435030004R1	
PCB	R747	C-CARBON R	RN72K1J-000JE	1	435030004R1	
PCB	R748	C-CARBON R	RN72K1J-000JE	1	435030004R1	

PCB	R750	C-CARBON R	RN72K1J-151JE	1	435031514R1	
PCB	R751	C-CARBON R	RN72K1J-272JE	1	435032724R1	
PCB	R752	C-CARBON R	RN72K1J-391JE	1	435033914R1	
PCB	R753	C-CARBON R	RN72K1J-471JE	1	435034714R1	
PCB	R754	C-CARBON R	RN72K1J-821JE	1	435038214R1	
PCB	R755	C-CARBON R	RN72K1J-102JE	1	435031024R1	
PCB	R758	C-CARBON R	RN72K1J-272JE	1	435032724R1	
PCB	R759	C-CARBON R	RN72K1J-391JE	1	435033914R1	
PCB	R760	C-CARBON R	RN72K1J-471JE	1	435034714R1	
PCB	R761	C-CARBON R	RN72K1J-821JE	1	435038214R1	
PCB	R762	C-CARBON R	RN72K1J-102JE	1	435031024R1	
PCB	R763	C-CARBON R	RN72K1J-182JE	1	435031824R1	
PCB	R764	C-CARBON R	RN72K1J-392JE	1	435033924R1	
PCB	R765	C-CARBON R	RN72K1J-103JE	1	435031034R1	
PCB	R766	C-CARBON R	RN72K1J-272JE	1	435032724R1	
PCB	R767	C-CARBON R	RN72K1J-391JE	1	435033914R1	
PCB	R768	C-CARBON R	RN72K1J-471JE	1	435034714R1	
PCB	R769	C-CARBON R	RN72K1J-821JE	1	435038214R1	
PCB	R770	C-CARBON R	RN72K1J-102JE	1	435031024R1	
PCB	R771	C-CARBON R	RN72K1J-182JE	1	435031824R1	
PCB	R772	C-CARBON R	RN72K1J-392JE	1	435033924R1	
PCB	R773	C-CARBON R	RN72K1J-103JE	1	435031034R1	
PCB	R779	C-CARBON R	RN72K1J-471JE	1	435034714R1	
PCB	P501	BNC JACK	P2298	1	25045634	<MDD>
PCB	P501	BNC JACK	P2298	1	25045634	<MUA>
PCB	P502	PIN JACK	NPJ-3PDGLR429	1	25045622	<MDD>
PCB	P502	PIN JACK	NPJ-3PDGLR429	1	25045622	<MUA>
PCB	P503	PIN JACK	NPJ-10PDBY518	1	25045730	<MDD>
PCB	P503	PIN JACK	NPJ-10PDBY518	1	25045730	<MUA>
PCB	P504	PIN JACK	NPJ-2PDB400	1	25045589	<MDD>
PCB	P504	PIN JACK	NPJ-2PDB400	1	25045589	<MUA>
PCB	P505	ST JACK	HSJ1002-01-1020	1	25045647	<MDD>
PCB	P505	ST JACK	HSJ1002-01-1020	1	25045647	<MUA>
PCB	P506	SOCKET	NSCT-9P2277	1	25052379	<MDD>
PCB	P506	SOCKET	NSCT-9P2277	1	25052379	<MUA>
PCB	P701A	SOCKET AS	NSAS-16P1456	1	200HA391630UL	<MDD>
PCB	P701A	SOCKET AS	NSAS-16P1456	1	200HA391630UL	<MUA>
PCB	P701B	PLUG	NPLG-8P428	1	25055446	<MDD>
PCB	P701B	PLUG	NPLG-8P428	1	25055446	<MUA>
PCB	P702	SOCKET AS	NSAS-6P1140	1	2002A290625UL	
PCB	P702B	PLUG	NPLG-3P423	1	25055441	<MDD>
PCB	P702B	PLUG	NPLG-3P423	1	25055441	<MUA>
PCB	P703	SOCKET	NSCT-7P2241	1	25052344	
PCB	P703 or	SOCKET	NSCT-7P1676	(1)	25051889	
PCB	P703 or	SOCKET	NSCT-7P2425	(1)	25052528	
PCB	P901A	AC INLET	NPLG-2P913	1	25055960	<MDD>
PCB	P901A	AC INLET	NPLG-2P913	1	25055960	<MUA>
PCB	P902	SOCKET AS	NSAS-4P0994	1	2009990712AUL	<MDD>
PCB	P902	SOCKET AS	NSAS-4P0994	1	2009990712AUL	<MUA>
PCB	S701	PUSH SW	NPS-111-S681	1	25035718	
PCB	S702	PUSH SW	NPS-111-S681	1	25035718	
PCB	S703	PUSH SW	NPS-111-S681	1	25035718	
PCB	S704	PUSH SW	NPS-111-S681	1	25035718	
PCB	S705	PUSH SW	NPS-111-S681	1	25035718	
PCB	S706	PUSH SW	NPS-111-S681	1	25035718	
PCB	S707	PUSH SW	NPS-111-S681	1	25035718	
PCB	S708	PUSH SW	NPS-111-S681	1	25035718	
PCB	S709	PUSH SW	NPS-111-S681	1	25035718	
PCB	S710	PUSH SW	NPS-111-S681	1	25035718	
PCB	S712	PUSH SW	NPS-111-S681	1	25035718	
PCB	S713	PUSH SW	NPS-111-S681	1	25035718	
PCB	S714	PUSH SW	NPS-111-S681	1	25035718	
PCB	S715	PUSH SW	NPS-111-S681	1	25035718	
PCB	S716	PUSH SW	NPS-111-S681	1	25035718	
PCB	E802	HOLDER	(CRAMP) UA-0 V0	1	27190608-1	<MDD>

PCB	E802	HOLDER	(CRAMP) UA-0 V0	1	27190608-1	<MUA>
PCB	CN201A	SOCKET	NSCT-15P1684	1	25051897	
PCB	CN201Aor	SOCKET	NSCT-15P2249	(1)	25052352	
PCB	CN201Aor	SOCKET	NSCT-15P2433	(1)	25052536	
PCB	CN21B	SOCKET AS	NSAS-26P1455	1	200C4192640UL	<MDD>
PCB	CN21B	SOCKET AS	NSAS-26P1455	1	200C4192640UL	<MUA>
PCB	CN301B	SOCKET AS	NSAS-26P1384	1	200C4192612UL	<MDD>
PCB	CN301B	SOCKET AS	NSAS-26P1384	1	200C4192612UL	<MUA>
PCB	CN451B	SOCKET	NSCT-17P1611	1	25051824	<MDD>
PCB	CN451B	SOCKET	NSCT-17P1611	1	25051824	<MUA>
PCB	CN451Bor	SOCKET	NSCT-17P1813	(1)	25052026	<MDD>
PCB	CN451Bor	SOCKET	NSCT-17P1813	(1)	25052026	<MUA>
PCB	CN451Bor	SOCKET	NSCT-17P2110	(1)	25052213	<MDD>
PCB	CN451Bor	SOCKET	NSCT-17P2110	(1)	25052213	<MUA>
PCB	JL703A	WIRE HOL	NSCT-3P874	1	25051087	
PCB	JL703B	WIRE HOL	NSCT-3P874	1	25051087	

**DPS-6.5****PACKING PROCEDURE PARTS LIST****<Notes>**

! :Safety parts

&lt;MDD&gt; :North American area

&lt;MUA&gt; :Australia area

NOTE : THE COMPONENTS IDENTIFIED BY THE MARK  
! ARE CRITICAL FOR RISK OF FIRE AND  
ELECTRIC SHOCK. REPLACE ONLY WITH PART  
NUMBER SPECIFIED.

REF. NO.	NAME	DESCRIPTION	Q'TY	PART NO	REMARKS
PKG	A450	CARTON	1	29054275	N
PKG	A451	LABEL	2	29363464	<MUA>
PKG	A455	UPC LABEL	1	29363918	<MDD> N
PKG	A455	EAN LABEL	1	29363924	<MUA> N
PKG	A530	WRNTY CARD	1	29365089A	<MDD>
PKG	A601	PAD	1	29092194	
PKG	A604	POLY BAG	1	29100037-1A	
PKG	A605	POLY BAG	1	29100097-1A	
PKG	A606	TAPE	(1)	29110149	:0.3:MT
PKG	A607	PP TAPE	(1)	29110148	:1.3:MT
PKG	A901	CORD AS	1	2010412	
PKG	A901 or	PIN CORD AS	(1)	2010379	
PKG	A902	BATTERY	2	3010194	
PKG	A902 or	BATTERY	(2)	3010054	
PKG	A903	CORD AS	1	2010431	
PKG	A904	INS MANUAL	1	29343848	N
PKG	A905	REMO CON	1	24140583	N
PKG	A906	CORD AS	1	2010380	
PKG	A906 or	CORD AS	(1)	2010360	
PKG	P981	AC CORD	1	253352TES	<MDD>!
PKG	P981 or	AC CORD	(1)	253297KAW	<MDD>!
PKG	P981	AC CORD	1	253311VOL	<MUA>!

# DVD MAIN BOARD PARTS LIST-1

- NOTES: ● Parts marked by "NSP" are generally unavailable because they are not in our Master Spare Parts List.  
 ● The  $\Delta$  mark found on some component parts indicates the importance of the safety factor of the part. Therefore, when replacing, be sure to use parts of identical designation.  
 ● When ordering resistors, first convert resistance values into code form as shown in the following examples.  
 Ex.1 When there are 2 effective digits (any digit apart from 0), such as 560 ohm and 47k ohm (tolerance is shown by J=5%, and K=10%).  
     560 ohm  $\rightarrow$  56 x 10<sup>1</sup>  $\rightarrow$  561 ..... RD1/4PU 561J  
     47k ohm  $\rightarrow$  47 x 10<sup>3</sup>  $\rightarrow$  473 ..... RD1/4PU 473J  
     0.5 ohm  $\rightarrow$  R50 ..... RN2HR 50K  
     1 ohm  $\rightarrow$  1R0 ..... RS1P 1R0K  
 Ex.2 When there are 3 effective digits (such as in high precision metal film resistors).  
     5.62k ohm  $\rightarrow$  562 x 10<sup>1</sup>  $\rightarrow$  562 ..... RN1/4PC 562IF

Mark No.	Description	Part No.	Mark No.	Description	Part No.
<b>A LOAB ASSY</b> <b>SWITCHES AND RELAYS</b>			<b>B DVD MAIN BD ASSY</b> <b>SEMICONDUCTORS</b>		
S101		VSK1011	$\Delta$ IC321		BA00BC0WT
			IC502,IC602,IC702		BA4560F
			IC204		BR24L16FV-W
			IC202		K4S641632H-TC75
			IC101		M63018FP
			IC401		MM1623BF
			IC201		MT1389EE-L1
			$\Delta$ IC801		NJM78M05FA
			IC501,IC601,IC701		PCM1742KE
			$\Delta$ IC311		PQ1M505M2SPQ
			IC205		PST3228
			$\Delta$ IC341		S-L2980A33MC-C6S
			IC841		TC7SHU04FU
			IC203		VYW2202
			Q562,Q662,Q762		2SA1576A
			Q372,Q373		2SA1602A
			Q371,Q4,Q901		2SC4081
			Q541,Q542,Q544,Q545		2SD2114K
			Q641,Q642,Q741,Q742		2SD2114K
			Q7,Q8		HN1A01F
			Q592,Q593		HN1C01FU
			Q5		UM5K1N
			Q561,Q661,Q761		UMH9N
			D801		1SS355
			D591		UDZS6.8B
			<b>COILS AND FILTERS</b>		
			L421,L422 CHIP BEAD		VTL1089
			L311 CHIP BEAD		VTL1095
			<b>CAPACITORS</b>		
			C292,C293,C297		CCSRCH101J50
			C265		CCSRCH220J50
			C142,C227		CCSRCH221J50
			C294,C295,C903		CCSRCH330J50

**OTHERS**

CN602	KR CONNECTOR	S2B-PH-K
CN601	KR CONNECTOR	S5B-PH-K
	PC BOARD LOAB	VNP1879

## DVD MAIN BOARD PARTS LIST-2

<u>Mark No.</u>	<u>Description</u>	<u>Part No.</u>
	C507,C515,C516,C607	CCSRCH331J50
	C615,C616,C707,C715,C716 C254 C211,C212 C251 C252	CCSRCH331J50 CCSRCH391J50 CCSRCH561J50 CCSRCH8R0D50 CCSRCH9R0D50
	C256,C506 C401,C405,C511,C512,C517 C611,C612,C617,C711,C712 C717,C804,C911 C281,C421,C422,C501	CEAT100M50 CEAT101M10 CEAT101M10 CEAT101M10 CEAT102M6R3
	C901 C201,C202,C237,C302,C601 C701,C73 C10,C203,C206,C215 C521,C522,C531,C591	CEAT1R0M50 CEAT221M6R3 CEAT221M6R3 CEAT470M16 CEAT470M16
	C621,C622,C721,C722,C801 C9 C423,C424 C11,C124,C230,C267,C296 C298,C304,C505,C913	CEAT470M16 CEAT470M16 CEAT471M6R3 CKSRYB102K50 CKSRYB102K50
	C130,C134,C136,C226 C313,C606,C706 C219 C209 C112-C114,C513,C514	CKSRYB103K50 CKSRYB105K10 CKSRYB152K50 CKSRYB153K25 CKSRYB222K50
	C613,C614,C713,C714 C269 C208,C210 C258,C259 C255	CKSRYB222K50 CKSRYB333K16 CKSRYB472K50 CKSRYB473K50 CKSRYB474K10
	C125,C204,C205,C207 C213,C214,C216,C217,C220 C222-C225,C228,C231-C236 C239-C241,C244-C246,C253 C257,C260,C262,C264,C266	CKSRYF104Z25 CKSRYF104Z25 CKSRYF104Z25 CKSRYF104Z25 CKSRYF104Z25
	C268,C270-C273,C282 C284-C288,C290,C312,C402 C404,C411,C415,C416,C502 C532,C602,C605,C632,C702 C705,C71,C72,C732,C74	CKSRYF104Z25 CKSRYF104Z25 CKSRYF104Z25 CKSRYF104Z25 CKSRYF104Z25
	C102,C132,C139,C243,C261 C263,C283,C289,C303,C311 C321,C341,C342,C412-C414 C43-C46,C504,C518 C592,C593,C6,C618,C718	CKSRYF105Z10 CKSRYF105Z10 CKSRYF105Z10 CKSRYF105Z10 CKSRYF105Z10
	C841,C912	CKSRYF105Z10
<b><u>RESISTORS</u></b>		
	R222,R225 R515,R520,R615,R620,R715 R720 R511,R514,R611,R614,R711 R714	RAB4C330J RN1/16SE1002D RN1/16SE1002D RN1/16SE5601D RN1/16SE5601D
	R207-R209,R217 R904 R562,R662,R762 R103,R106 R104,R107	RS1/10S0R0J RS1/10S151J RS1/10S182J RS1/10S1R0J RS1/10S1R8J

<u>Mark No.</u>	<u>Description</u>	<u>Part No.</u>
	R115-R120 R421-R424 R262,R264,R268,R271,R274 R277 R279	RS1/10S4R7J RS1/10S75R0F RS1/16S1500F RS1/16S1500F RS1/16S2201F
	R321-R323 R905 Other Resistors	RS1/16S3302F RS1/16S75R0F RS1/16S###J

**OTHERS**

CN301	KR CONNECTOR	B13B-PH-K
CN103	KR CONNECTOR	B5B-PH-K
CN452	FFC CONNECTOR 5P	HLEM5S-1
JA502	4P PIN JACK	VKB1126
JA501	4P PIN JACK	VKB1132
JA401	4P PIN JACK	VKB1168
CN104	4P FFC CONNECTOR	VKN1235
CN102	12P FFC CONNECTOR	VKN1243
CN201	15P FFC CONNECTOR	VKN1246
CN101	24P FFC CONNECTOR	VKN1464
JA901	JACK	VKX1013
X201	CRYSTAL RESONATOR (27MHz)	VSS1168

**B DVDM ASSY [VWS1583]****SEMICONDUCTORS**

△ IC321 IC502,IC602,IC702 IC204 IC202 IC101	BA00BC0WT BA4560F BR24L16FV-W K4S641632H-TC75 M63018FP
IC471 IC472 IC451 IC401 IC201	MM1505XN MM1507XN MM1566AJ MM1623BF MT1389EE-L1
△ IC801 IC501,IC601,IC701	NJM78M05FA PCM1742KE
△ IC311 IC205	PQ1M505M2SPQ PST3228
△ IC341	S-L2980A33MC-C6S
IC841 IC203 Q482,Q492,Q562,Q662,Q762 Q372,Q373 Q371,Q4,Q481,Q491,Q901	TC7SHU04FU VYW2202 2SA1576A 2SA1602A 2SC4081
Q541-Q546,Q641,Q642 Q741,Q742 Q401 Q7,Q8 Q592,Q593	2SD2114K 2SD2114K DTC114YUA HN1A01F HN1C01FU
Q5 Q561,Q661,Q761 D471-D474,D481,D801 D591	UM5K1N UMH9N 1SS355 UDZS6.8B
<b><u>COILS AND FILTERS</u></b>	
L421,L422 CHIP BEAD L311 CHIP BEAD	VTL1089 VTL1095
<b><u>CAPACITORS</u></b>	

## DVD MAIN BOARD PARTS LIST-3

<u>Mark No.</u>	<u>Description</u>	<u>Part No.</u>	<u>Mark No.</u>	<u>Description</u>	<u>Part No.</u>
C292,C293,C297		CCSRCH101J50	R207-R209,R217		RS1/10S0R0J
C265		CCSRCH220J50	R904		RS1/10S151J
C142,C227		CCSRCH221J50	R562,R662,R762		RS1/10S182J
C294,C295,C903		CCSRCH330J50	R103,R106		RS1/10S1R0J
C507,C515,C516,C607		CCSRCH331J50	R104,R107		RS1/10S1R8J
C615,C616,C707,C715,C716		CCSRCH331J50	R115-R120		RS1/10S4R7J
C254		CCSRCH391J50	R421-R424		RS1/10S75R0F
C211,C212		CCSRCH561J50	R262,R264,R268,R271,R274		RS1/16S1500F
C251		CCSRCH8R0D50	R277		RS1/16S1500F
C252		CCSRCH9R0D50	R279		RS1/16S2201F
C256,C471,C506		CEAT100M50	R321-R323		RS1/16S3302F
C401,C405,C454,C511,C512		CEAT101M10	R905		RS1/16S75R0F
C517,C611,C612,C617		CEAT101M10	Other Resistors		RS1/16S###J
C711,C712,C717,C804,C911		CEAT101M10			
C281,C421,C422,C501		CEAT102M6R3			
C901		CEAT1R0M50			
C201,C202,C237,C302,C601		CEAT221M6R3			
C701,C73		CEAT221M6R3			
C10,C203,C206,C215		CEAT470M16			
C521,C522,C531,C591		CEAT470M16			
C621,C622,C721,C722,C801		CEAT470M16			
C9		CEAT470M16			
C423,C424		CEAT471M6R3			
C11,C124,C230,C267,C296		CKSRYB102K50			
C298,C304,C505,C913		CKSRYB102K50			
C130,C134,C136,C226		CKSRYB103K50			
C313,C606,C706		CKSRYB105K10			
C219		CKSRYB152K50			
C209		CKSRYB153K25			
C112-C114,C513,C514		CKSRYB222K50			
C613,C614,C713,C714		CKSRYB222K50			
C269		CKSRYB333K16			
C208,C210		CKSRYB472K50			
C258,C259		CKSRYB473K50			
C255		CKSRYB474K10			
C125,C204,C205,C207		CKSRYF104Z25			
C213,C214,C216,C217,C220		CKSRYF104Z25			
C222-C225,C228,C231-C236		CKSRYF104Z25			
C239-C241,C244-C246,C253		CKSRYF104Z25			
C257,C260,C262,C264,C266		CKSRYF104Z25			
C268,C270-C273,C282		CKSRYF104Z25			
C284-C288,C290,C312,C402		CKSRYF104Z25			
C404,C411,C415,C416,C453		CKSRYF104Z25			
C461-C463,C472-C476,C482		CKSRYF104Z25			
C492,C502,C532,C602,C605		CKSRYF104Z25			
C632,C702,C705,C71,C72		CKSRYF104Z25			
C732,C74		CKSRYF104Z25			
C102,C132,C139,C243,C261		CKSRYF105Z10			
C263,C283,C289,C303,C311		CKSRYF105Z10			
C321,C341,C342,C412-C414		CKSRYF105Z10			
C43-C46,C504,C518		CKSRYF105Z10			
C592,C593,C6,C618,C718		CKSRYF105Z10			
C841,C912		CKSRYF105Z10			

**OTHERS**

CN301	KR CONNECTOR	B13B-PH-K
CN103	KR CONNECTOR	B5B-PH-K
CN451	FFC CONNECTOR 17P	HLEM17S-1
JA502	4P PIN JACK	VKB1126
JA501	4P PIN JACK	VKB1132
JA401	4P PIN JACK	VKB1168
CN104	4P FFC CONNECTOR	VKN1235
CN102	12P FFC CONNECTOR	VKN1243
CN201	15P FFC CONNECTOR	VKN1246
CN101	24P FFC CONNECTOR	VKN1464
JA901	JACK	VKX1013
X201	CRYSTAL RESONATOR (27MHz)	VSS1168

**RESISTORS**

R222,R225	RAB4C330J
R515,R520,R615,R620,R715	RN1/16SE1002D
R720	RN1/16SE1002D
R511,R514,R611,R614,R711	RN1/16SE5601D
R714	RN1/16SE5601D



---

Integra Division of

**ONKYO CORPORATION**

Sales & Product Planning Div. : 2-1, Nisshin-cho, Neyagawa-shi, OSAKA 572-8540, JAPAN

Tel: 072-831-8023 Fax: 072-831-8124 <http://www.onkyo.com/jp/>

Integra Division of

**ONKYO U.S.A. CORPORATION**

18 Park Way, Upper Saddle River, N.J. 07458, U.S.A.

Tel: 201-785-2600 Fax: 201-785-2650 <http://www.integrahometheater.com>