

# Integra SERVICE MANUAL

## AV RECEIVER MODEL DTR-50.1(B)

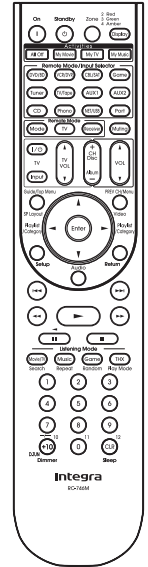
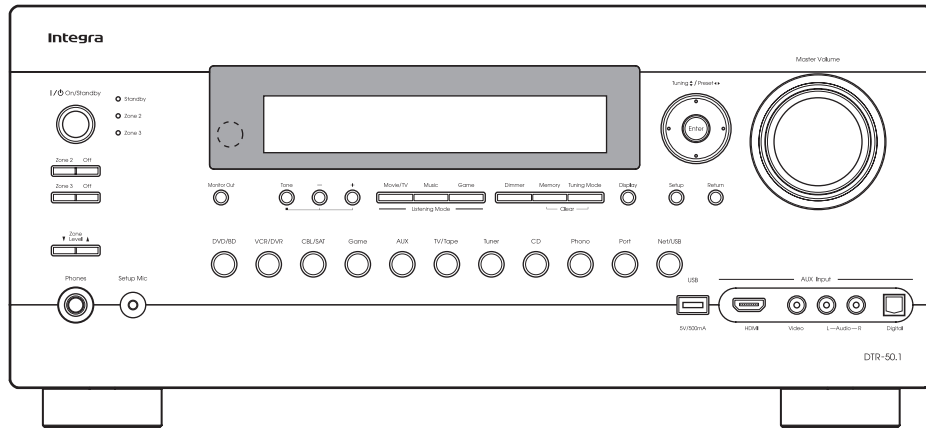

Black model

RC-746M

B MDD	120V AC, 60Hz
B MMA	220-240V AC, 50/60Hz

### SAFETY-RELATED COMPONENT WARNING!!

COMPONENTS IDENTIFIED BY MARK  ON THE SCHEMATIC DIAGRAM AND IN THE PARTS LIST ARE CRITICAL FOR RISK OF FIRE AND ELECTRIC SHOCK. REPLACE THESE COMPONENTS WITH ONKYO PARTS WHOSE PART NUMBERS APPEAR AS SHOWN IN THIS MANUAL.

MAKE LEAKAGE-CURRENT OR RESISTANCE MEASUREMENTS TO DETERMINE THAT EXPOSED PARTS ARE ACCEPTABLY INSULATED FROM THE SUPPLY CIRCUIT BEFORE RETURNING THE APPLIANCE TO THE CUSTOMER.

# SERVICE PROCEDURE-1

## 1. Replacing the fuses

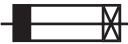
 This symbol located near the fuse indicates that the fuse used is slow operating type. For continued protection against fire hazard, replace with same type fuse. For fuse rating, refer to the marking adjacent to the symbol.

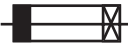
 Ce symbole indique que le fusible utilise est e lent. Pour une protection permanente, n'utiliser que des fusibles de meme type. Ce demier est indique la qu le present symbol est appose.

### <Notes>

<DD> : DTR-50.1 North American model

<MA> : DTR-50.1 Australian model

REF NO.	PART NAME	DESCRIPTION	PART NO.	REMARKS
F4000	FUSE	4A-UL/T-233	252325GR	!
F4000 or	FUSE	4A-T/UL-ST2	252257GR	!
F4001	FUSE	4A-UL/T-233	252325GR	!
F4001 or	FUSE	4A-T/UL-ST2	252257GR	!
F6901	FUSE	15A-TUL-250V	252303GR	!
F6902	FUSE	15A-TUL-250V	252303GR	!
F901	FUSE	10A-UL/T-233	252330GR	! <DD>
F901 or	FUSE	10A-T/UL-ST2	252333GR	! <DD>
D901	FUSE	5A-SE-EAK FUSE	252078GR	! <MA>
F901 or	FUSE	5A-SE-TL250V	252278GR	! <MA>

## 2. To initialize the unit

1. Press and hold down VCR/DVR button, then press ON/STANDBY button when the unit is powered on.
2. After " *Clear* " is displayed, the preset memory and each mode stored in the memory are initialized and will return to the factory settings, and turn to Standby mode.

## 3. Safety check out

(U.S.A. model only)

After correcting the original service problem, perform the following safety check before releasing the unit to the customer.

### Leakage current Check

Measure the leakage current to a known earth ground (water pipe or conduct etc.) by connecting a leakage current tester between the earth ground and exposed metal parts of the unit (input/output ground terminals, screw heads or metal overlays etc.).

Plug the power supply cord directly into a 120Vac 60Hz wall socket and turn ON/STANDBY button on.

Any current measured must not exceed 0.5mA.

## 4. Memory Backup

This model uses a EE-PROM IC in order to retain radio presets and other settings. So, memory contents will be kept eternally with no care.

## SERVICE PROCEDURE-2

### 5. Replacing Power Amplifier Parts

When a power amplifier of certain channel is broken and goes into Protect mode, the following parts in the channel must be replaced at the sametime, because these parts also get damage in most cases.

Front L ch	Front R ch	Center ch	Surround L ch	Surround R ch	Surround Back L ch	Surround Back R ch
Q6000,Q6010	Q6001,Q6011	Q6002,Q6012	Q6003,Q6013	Q6004,Q6014	Q6005,Q6015	Q6006,Q6016
Q6030,Q6040	Q6031,Q6041	Q6032,Q6042	Q6033,Q6043	Q6034,Q6044	Q6035,Q6045	Q6036,Q6046
Q6100,Q6110	Q6101,Q6111	Q6052,Q6062	Q6053,Q6063	Q6054,Q6064	Q6055,Q6065	Q6056,Q6066
Q6050,Q6060	Q6051,Q6061	Q6082,Q6092	Q6083,Q6093	Q6084,Q6094	Q6085,Q6095	Q6086,Q6096
Q6070	Q6071	Q6072	Q6073	Q6074	Q6075	Q5096
Q5000,Q5010	Q5001,Q5010	Q5002,Q5012	Q5003,Q5013	Q5004,Q5014	Q5005,Q5015	Q5006,Q5016
Q5030,Q5040	Q5031,Q5041	Q5032,Q5042	Q5033,Q5043	Q5034,Q5044	Q5035,Q5045	Q5036,Q5046
Q5050,Q5060	Q5051,Q5061	Q5052,Q5062	Q5053,Q5063	Q5054,Q5064	Q5055,Q5065	Q5056,Q5066
Q5070	Q5071	Q5072	Q8073	Q8074	Q8075	Q8076

BAAMP-0072 and BACLA-0087 are electrically and mechanically full-compatible with each other, but idling readjustment is necessary.

BAAMP-0072 and BACLA-0087 are also electrically and mechanically full-compatible with each other, but idling readjustment is necessary.

The parts listed above include the following driver-stage components in each pcb.

# ADJUSTMENT PROCEDURE

## ADJUSTMENT OF IDLING CURRENT

- 1) Setting R6040 to R6046 to minimum position before power ON.
- 2) Setting the voltage at P6080 to P6086 to 3mV by adjusting R6040 to R6046, under the condition of no input signal and no load, immediately after power ON.

L/C/R		SL/SR/SBL/ABR
Below 4mV	4mV	4mV
Between 4 ~ 6mV	Leave just as it is.	Leave just as it is.
Over 6mV	6mV	6mV

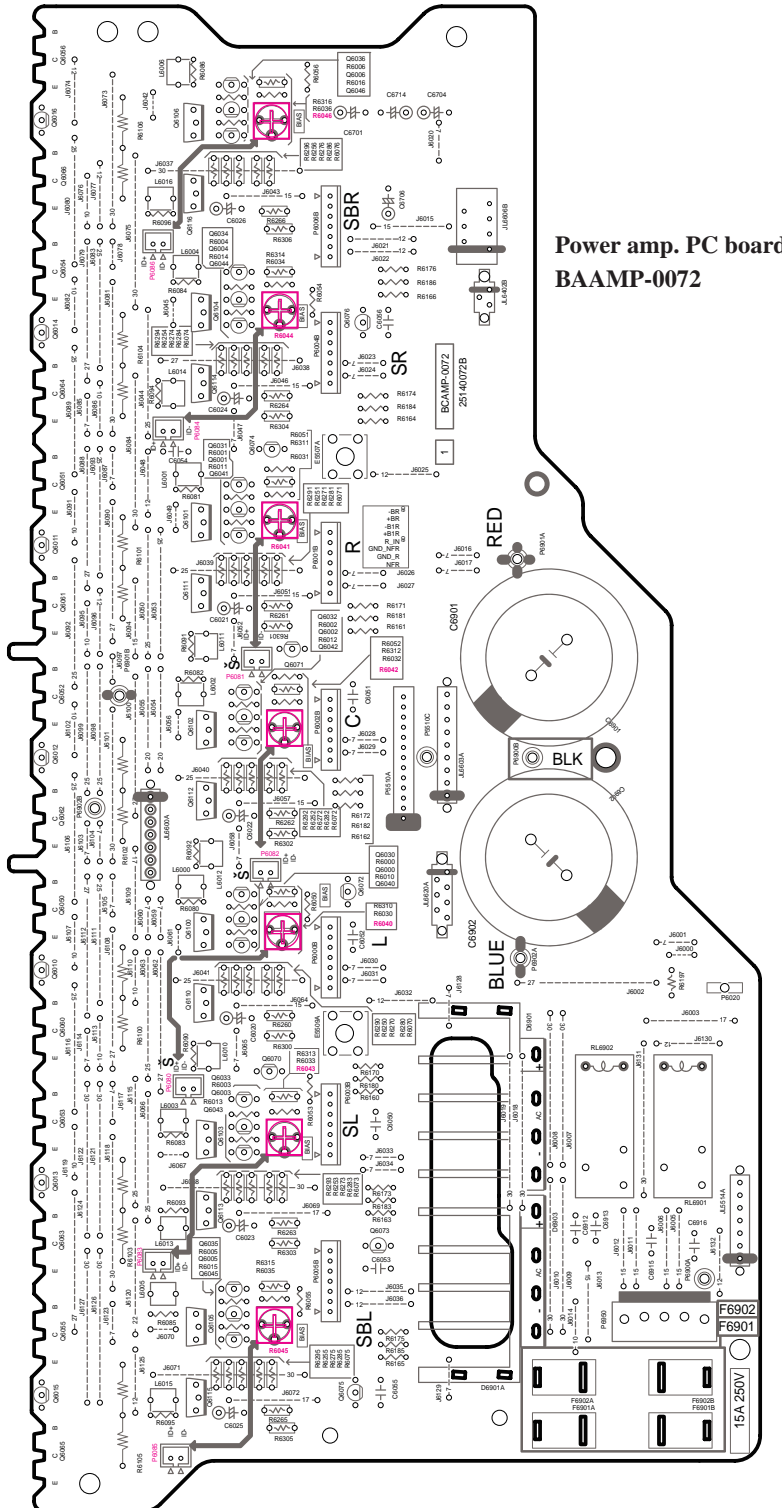



## EXPLODED VIEWS-2

&lt;Fig-1&gt;

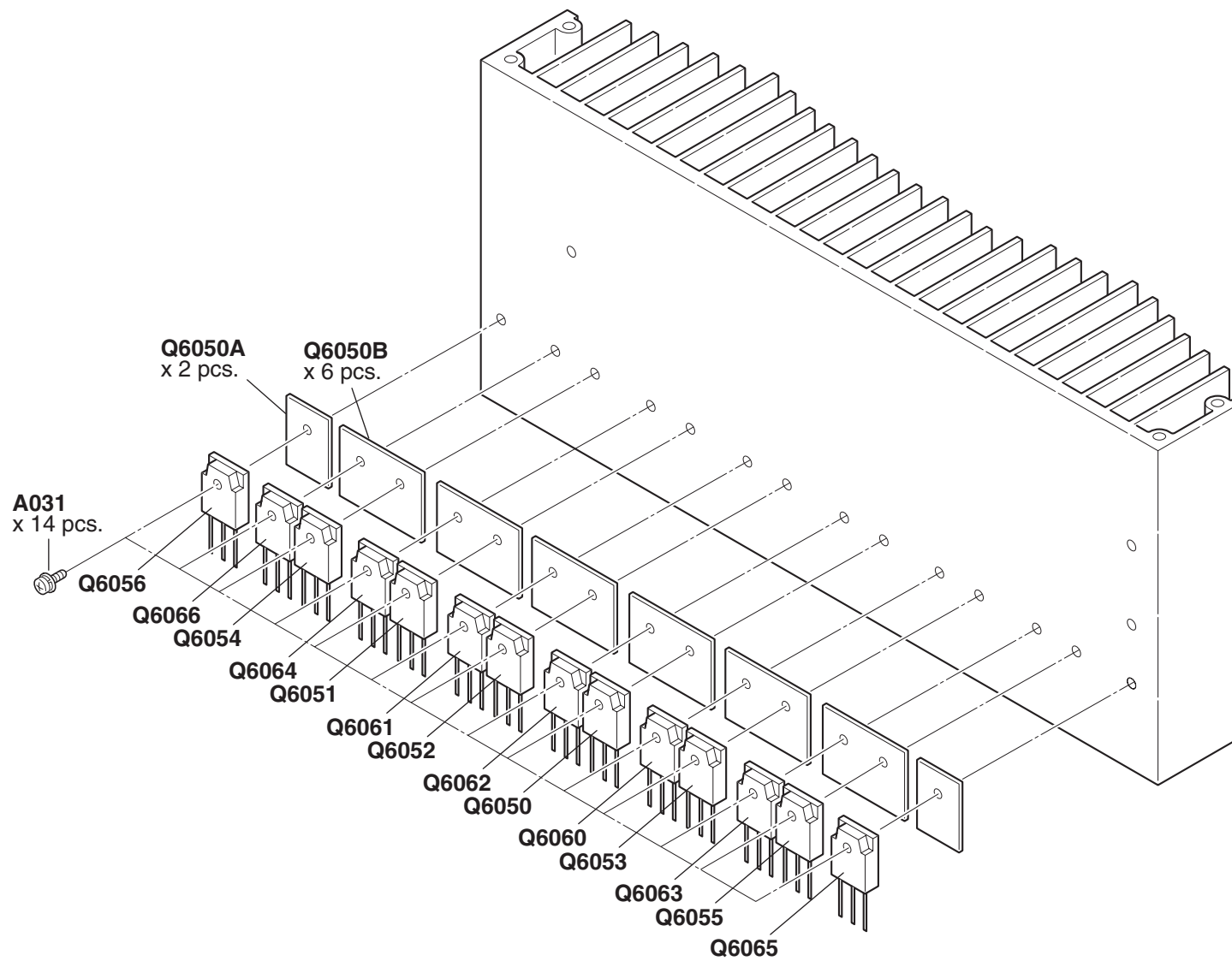

**BLOCK DIAGRAM-1**  
**AUDIO SECTION**

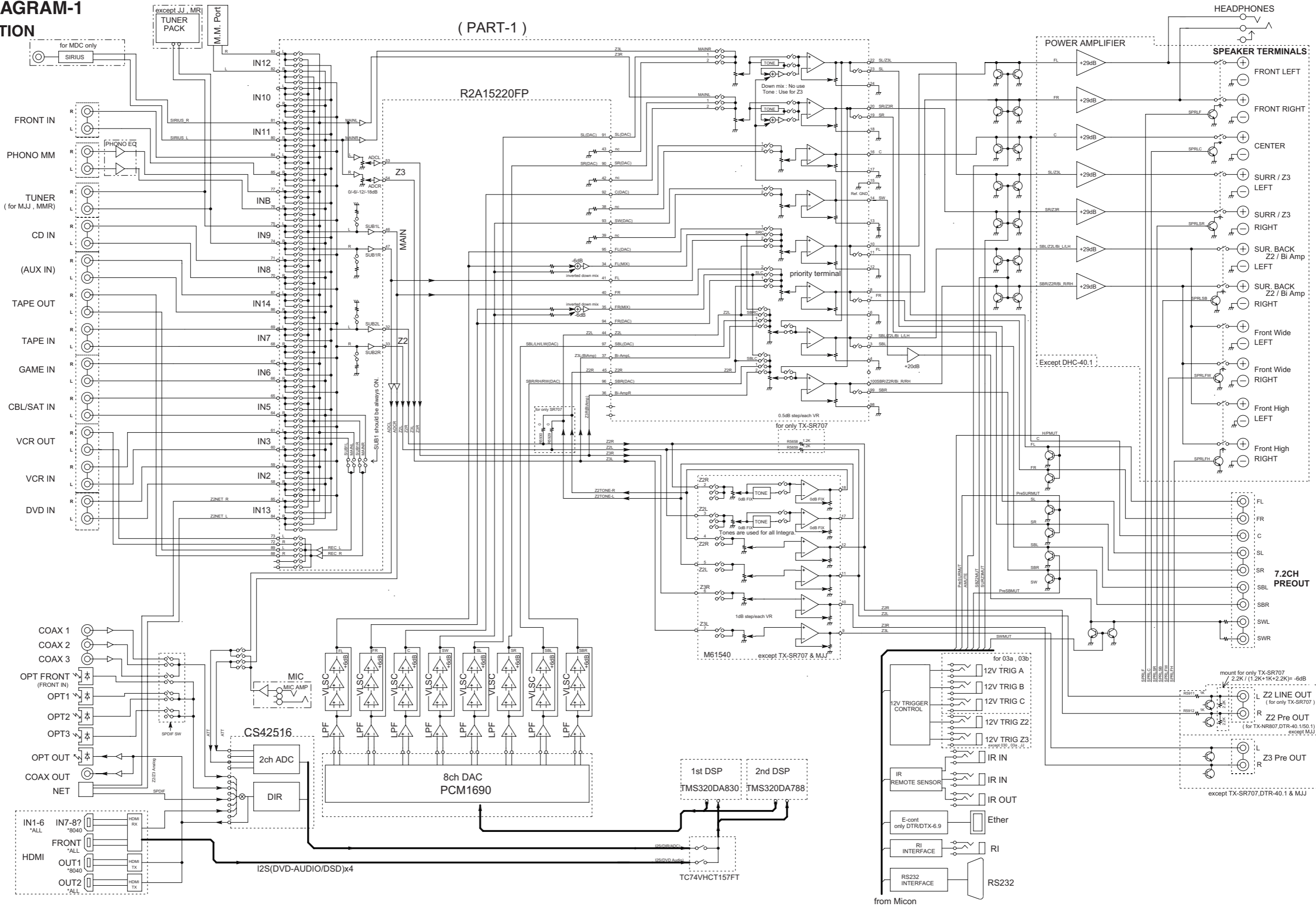

### BLOCK DIAGRAM-2 VIDEO SECTION

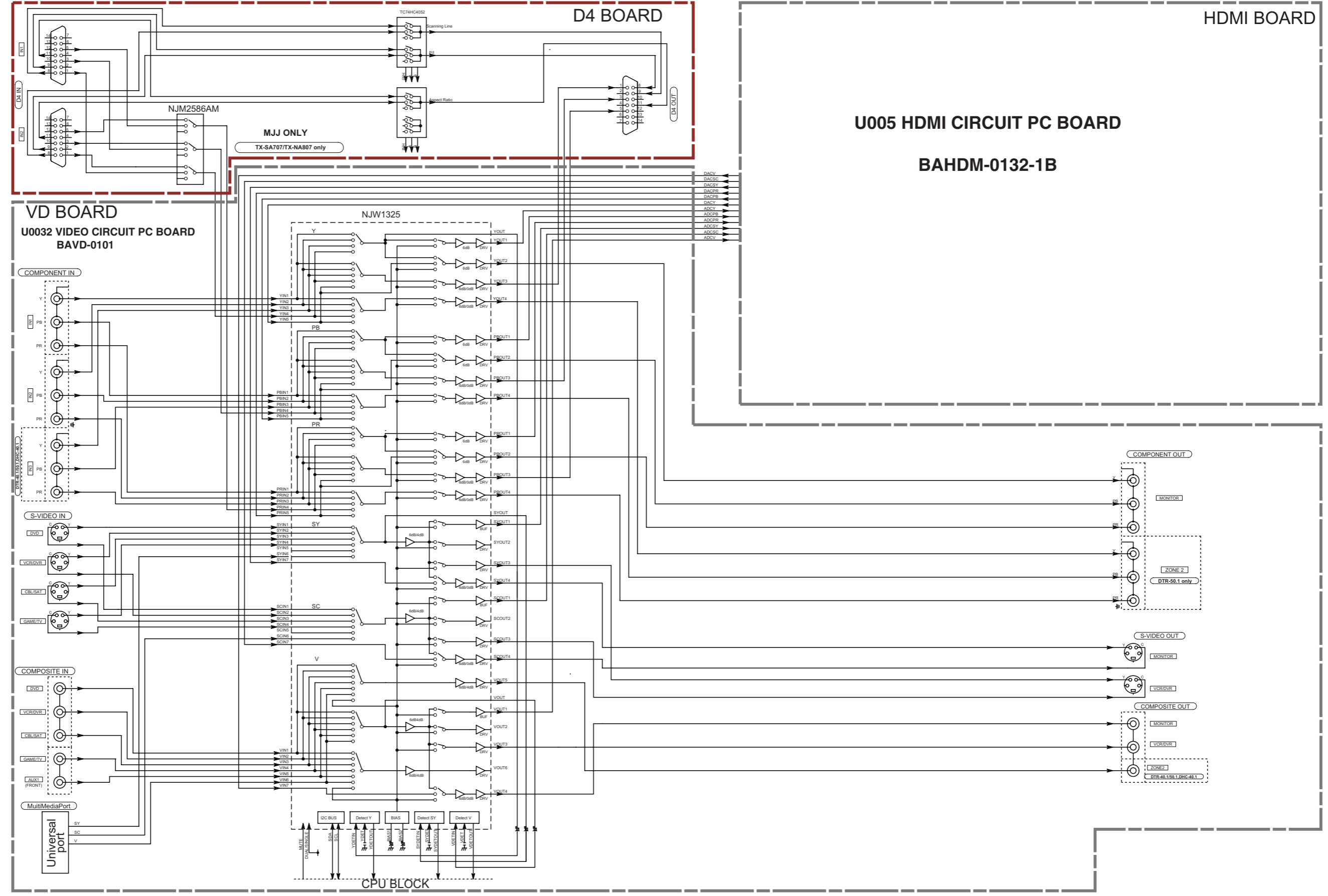



# BLOCK DIAGRAM-3

## HDMI SECTION

U005

HDMI CIRCUIT PC BOARD

BAHDM-0132

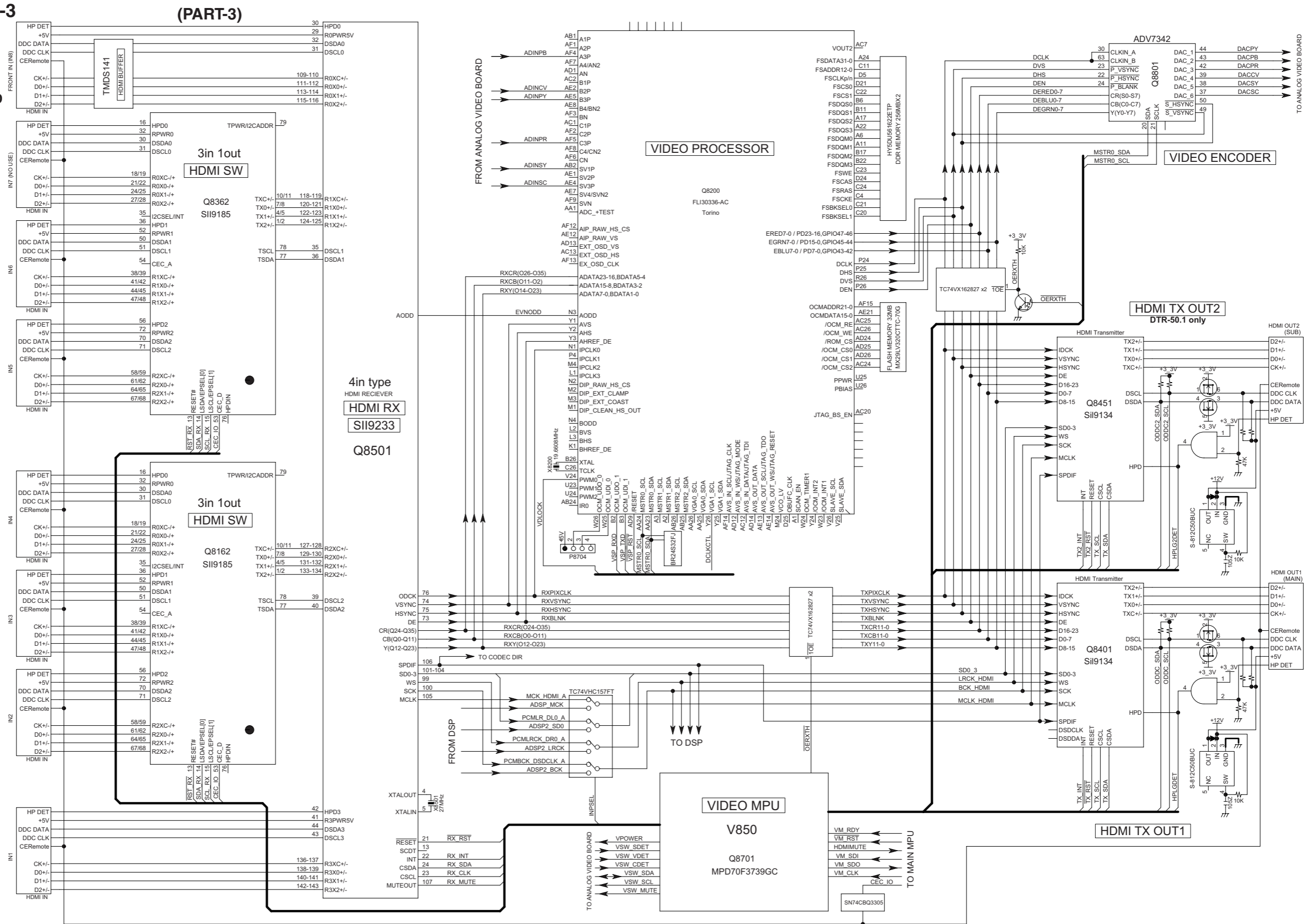

# BLOCK DIAGRAM-4 DSP/ ETHER/ USB SECTION

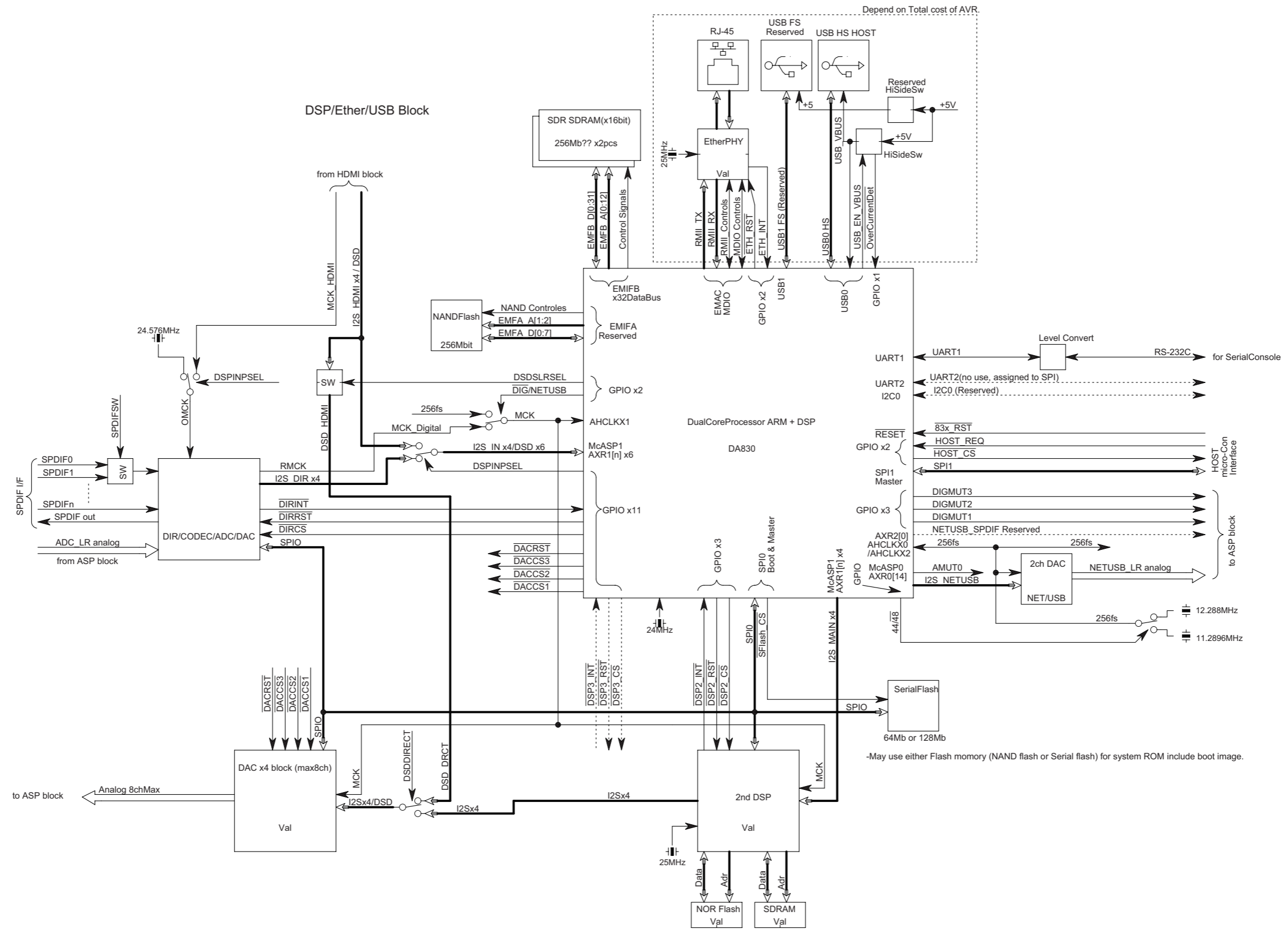

SCHEMATIC DIAGRAM-1

U0011 AUDIO INPUT CIRCUIT PC BOARD (BAASP-0073-1K) (PART-5)

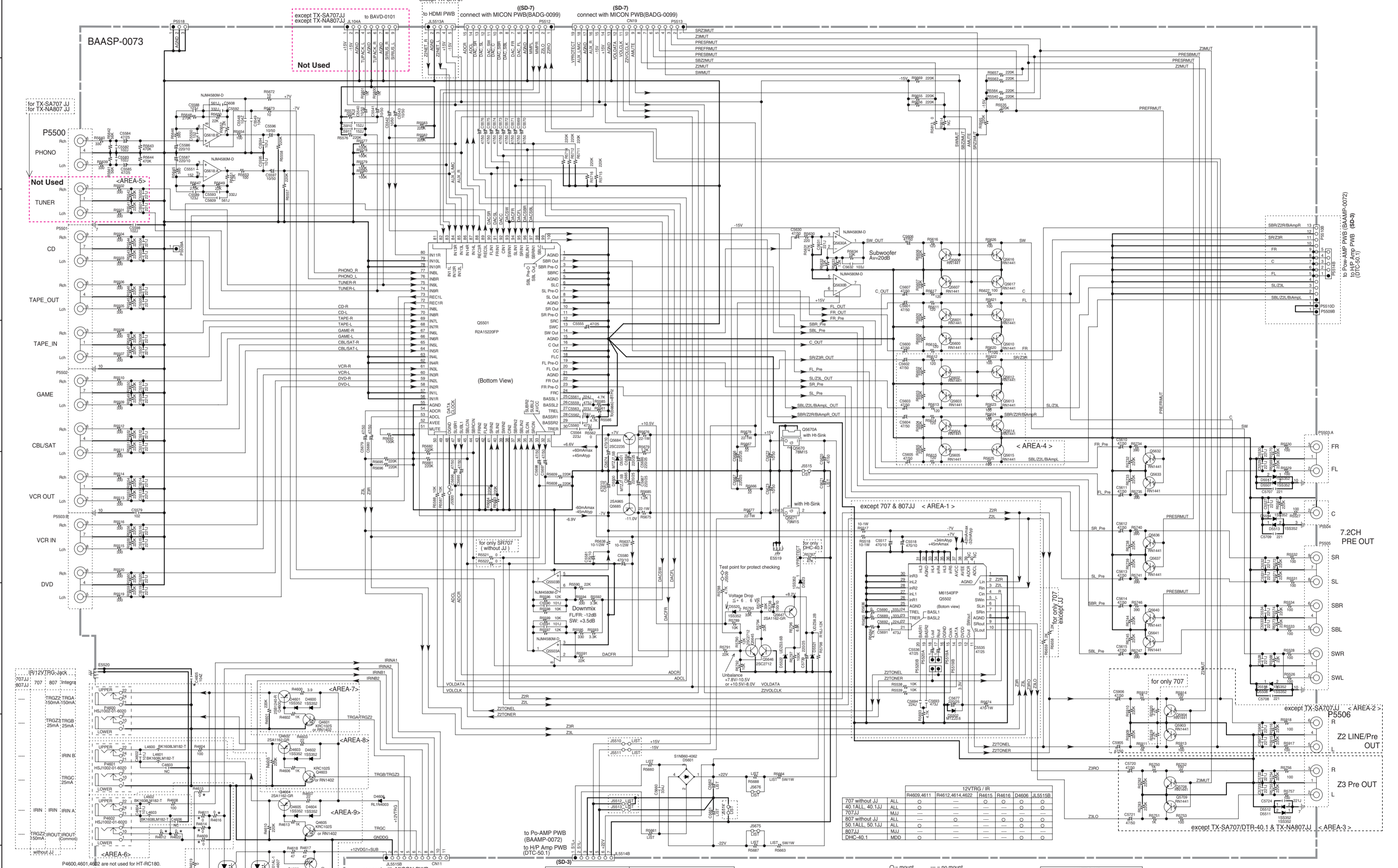

	R5660	R5661	R5668	J5676	R5664	C5662	R5687	J5675	R5663	C5661	C5671	AREA-1	R5658	R5659	AREA-2	AREA-3	AREA-4	AREA-5	J5510	J5511	J5512	J5513	J5514	J5515	P5510B	R5919	R5920	AREA-6	AREA-7	AREA-8	AREA-9	C4605		
TX-SR707 without JJ	ALL	1W-1.5	---	---	1W-6.8	1000/35	---	---	1W-6.8	470/35	220/50	---	---	---	---	---	---	---	---	---	---	---	---	---	---	---	---	---	---	---	---	---	---	
DTR-40.1 without JJ	---	1W-1.5	---	---	1W-6.8	1000/35	---	---	1W-6.8	470/35	220/50	---	---	---	---	---	---	---	---	---	---	---	---	---	---	---	---	---	---	---	---	---	---	---
DTR-40.1JJ	MAJ	1W-1.2	2W-6.8	---	1W-6.8	1000/35	1W-4.7	---	1W-6.8	470/35	220/50	---	---	---	---	---	---	---	---	---	---	---	---	---	---	---	---	---	---	---	---	---	---	---
TX-SA707JJ	MAJ	1W-1.5	---	---	1W-6.8	1000/35	---	---	1W-6.8	470/35	220/50	---	---	---	---	---	---	---	---	---	---	---	---	---	---	---	---	---	---	---	---	---	---	---
TX-NP807 without JJ	ALL	1W-1.5	---	---	5W-15	1000/50	---	---	5W-15	470/50	220/50	---	---	---	---	---	---	---	---	---	---	---	---	---	---	---	---	---	---	---	---	---	---	---
DTR-50.1 without JJ	---	1W-1.5	---	---	5W-15	1000/50	---	---	5W-15	470/50	220/50	---	---	---	---	---	---	---	---	---	---	---	---	---	---	---	---	---	---	---	---	---	---	---
DTR-50.1JJ	MAJ	1W-1.2	2W-6.8	---	5W-15	1000/50	---	---	5W-15	470/50	220/50	---	---	---	---	---	---	---	---	---	---	---	---	---	---	---	---	---	---	---	---	---	---	---
TX-NA807JJ	MAJ	1W-1.5	---	---	5W-15	1000/50	---	---	5W-15	470/50	220/50	---	---	---	---	---	---	---	---	---	---	---	---	---	---	---	---	---	---	---	---	---	---	---
DHC-40.1	MDD	1W-1.5	---	---	1W-6.8	1000/35	---	---	1W-6.8	1000/35	47/50	---	---	---	---	---	---	---	---	---	---	---	---	---	---	---	---	---	---	---	---	---	---	---

Look at the List about parts marked \*

Legend: O = mount, --- = no mount

A B C D E F G H

SCHEMATIC DIAGRAM-2

**U0024**  
**POWER AMP. INPUT CIRCUIT**  
**(INPUT STAGE) PC BOARD**  
**BACLA-0087-1G/1H**  
**(PART-6)**

1

2

3

4

5

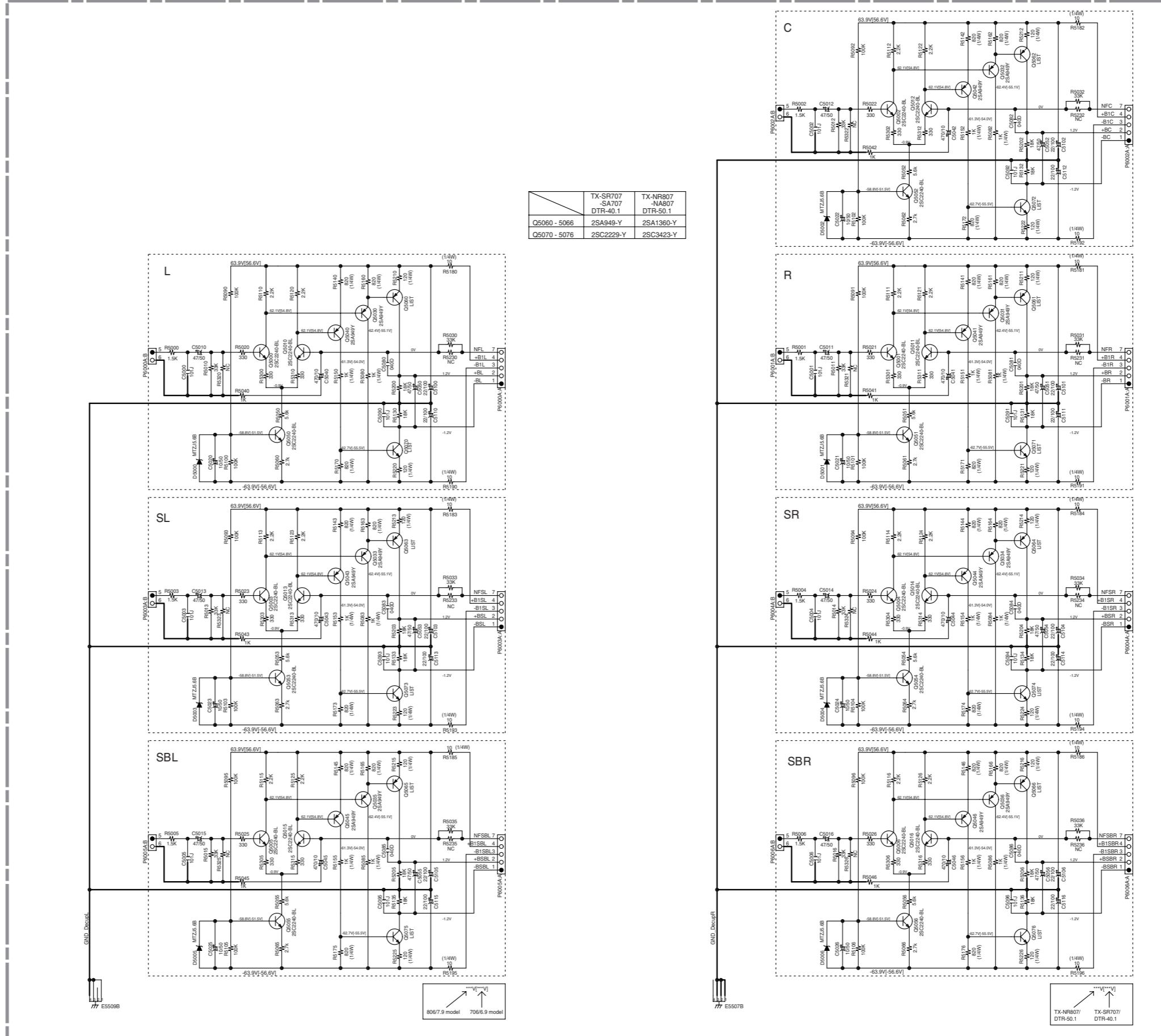

SCHEMATIC DIAGRAM-3

U0010 POWER AMPLIFIER CIRCUIT PC BOARD (BAAMP-0072-1K) (PART-7)

POWER AMP(Final Stage) SECTION

BAAMP-0072

TX-SR707 / DTR-40.1	TX-NR807 / DTR-50.1
Q6050 - Q6056	2SC5242 TTC001
Q6060 - Q6066	2SA1962 TTA0001

U0014 AC INLET TERMINAL PC BOARD BAETC-0089-1K

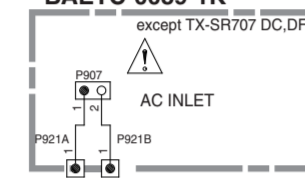

U0012 THERMISTOR PC BOARD BAETC-0074-1K

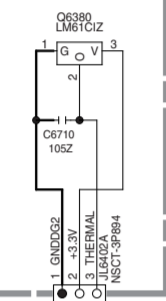

U0013 CONNECTION BOARD BAETC-0075-1K

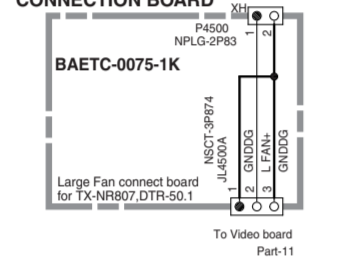

TO SPEAKER TERMINAL PC BOARD BAETC-0083 (PART 10) (SD-4)

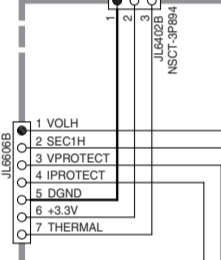

PROTECT

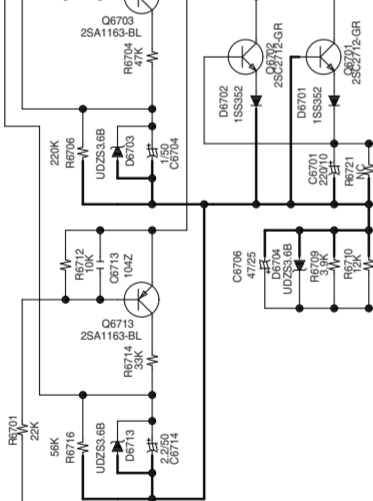

FROM TRANS (PART 7)

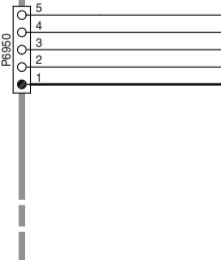

FROM ASP board (PART 7)

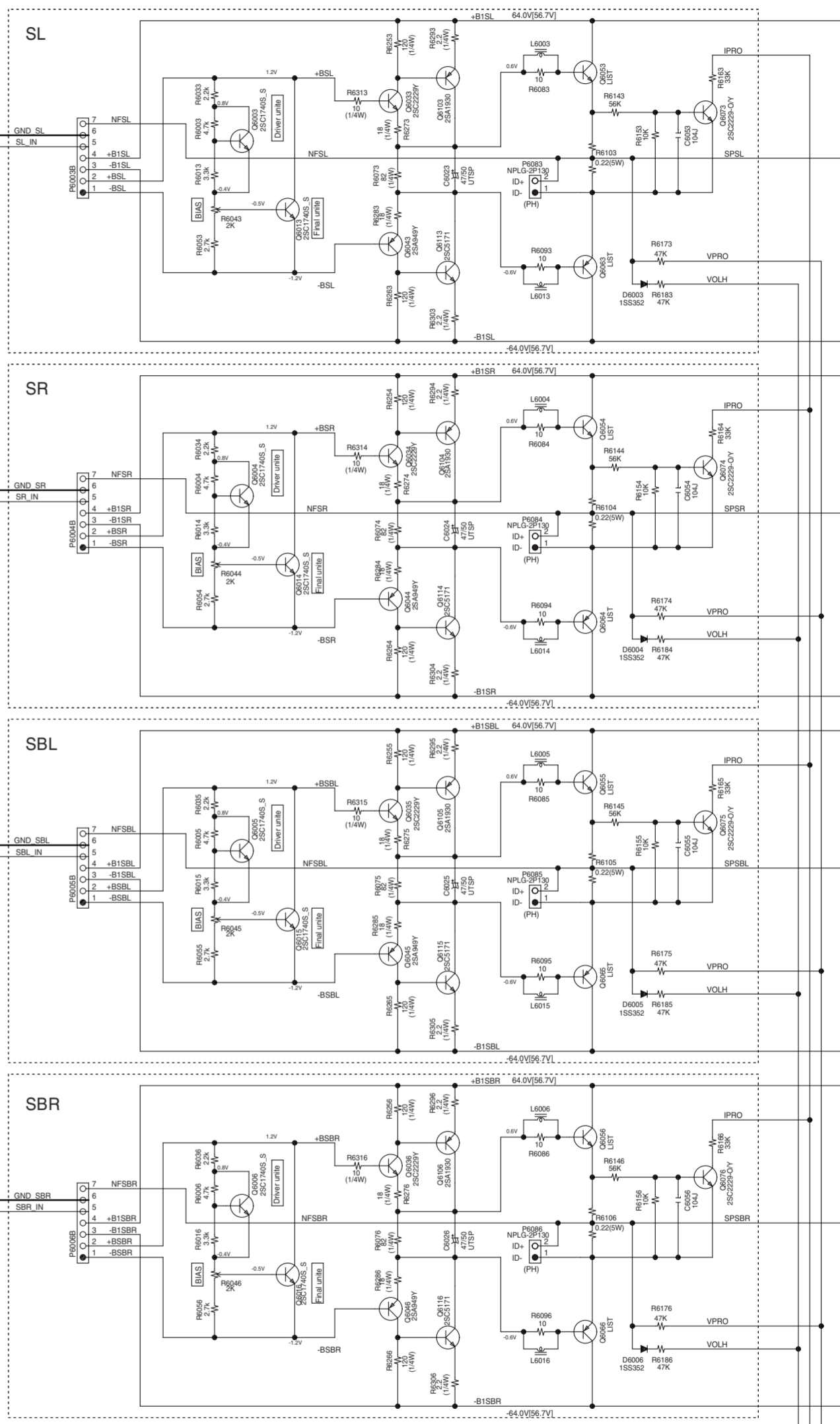
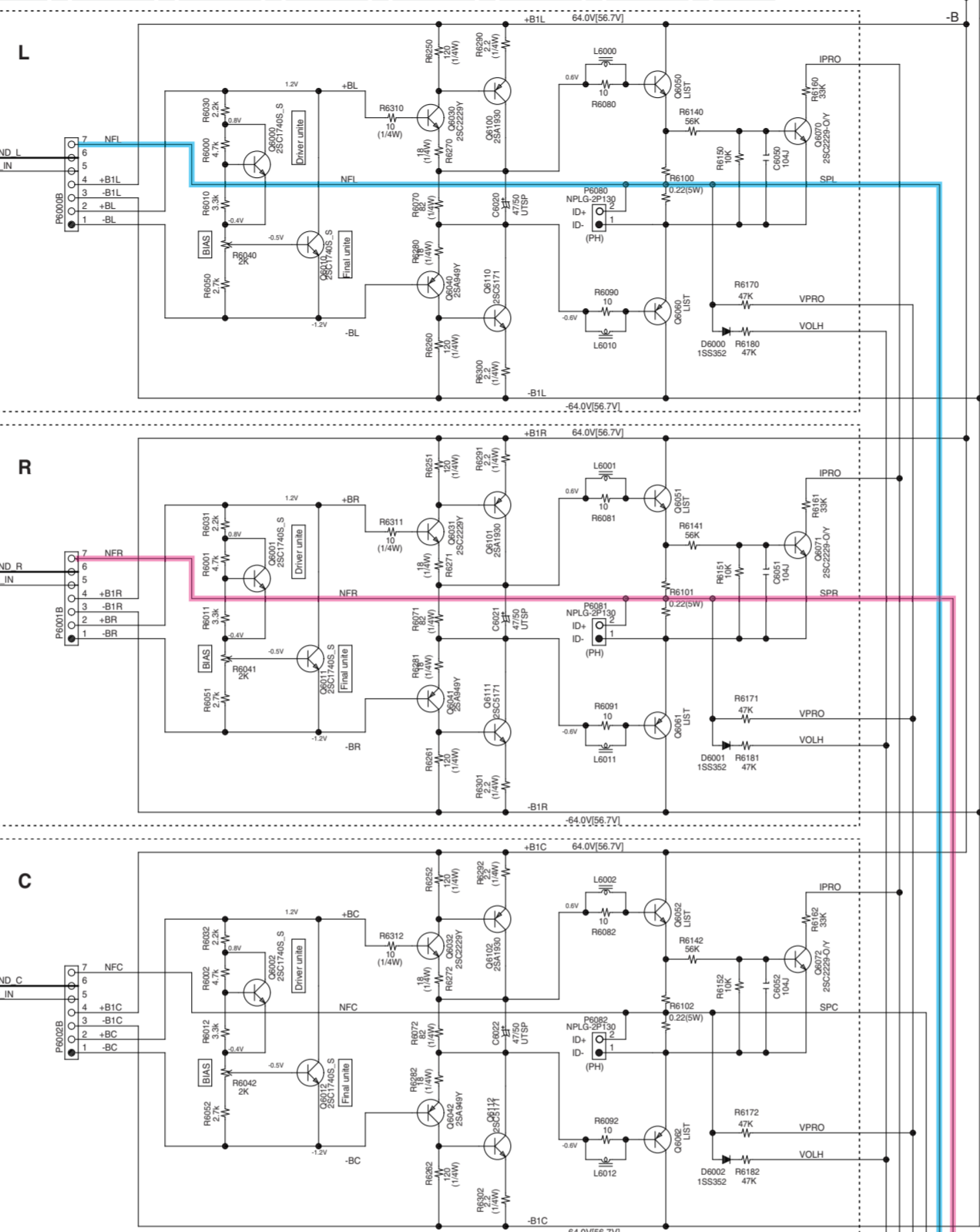
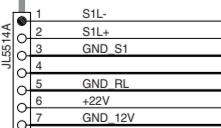

CONN	MODEL
C9901	12000u6sh TX-SR707 DTR-40.1 DC
C9902	12000u71y TX-SR707 DTR-40.1 excpt DC
C9903	15000u71v TX-NR807 DTR-50.1

TO SPEAKER TERMINAL PC BOARD BAETC-0083 (PART 10) (SD-4)

TO SPEAKER TERMINAL PC BOARD BAETC-0083 (PART 7) (SD-1)

TO SPEAKER TERMINAL PC BOARD BAETC-0083 (PART 7) (SD-1)

TO SPEAKER TERMINAL PC BOARD BAETC-0083 (PART 10) (SD-4)

TO SPEAKER TERMINAL PC BOARD BAETC-0083 (PART 7) (SD-1)

TX-NR807 / DTR-50.1

TX-SR707 / DTR-40.1

SCHEMATIC DIAGRAM-4

AREA-1

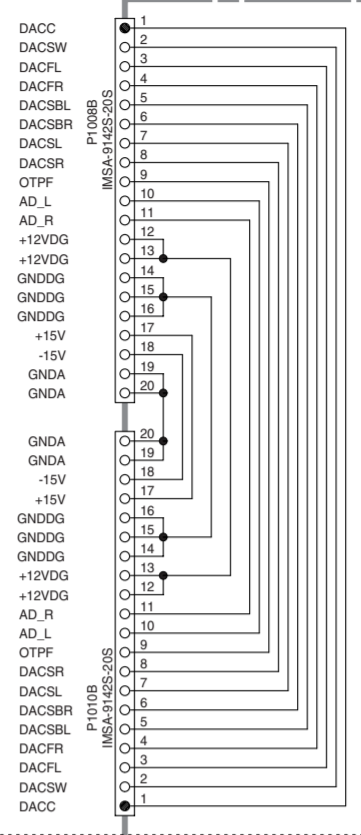

SP TARMINAL

**U0020 SPEAKER TERMINAL-1 PC BOARD**  
BATRM-0083-1G/-1H  
(PART-8)

**BATRM-0083**

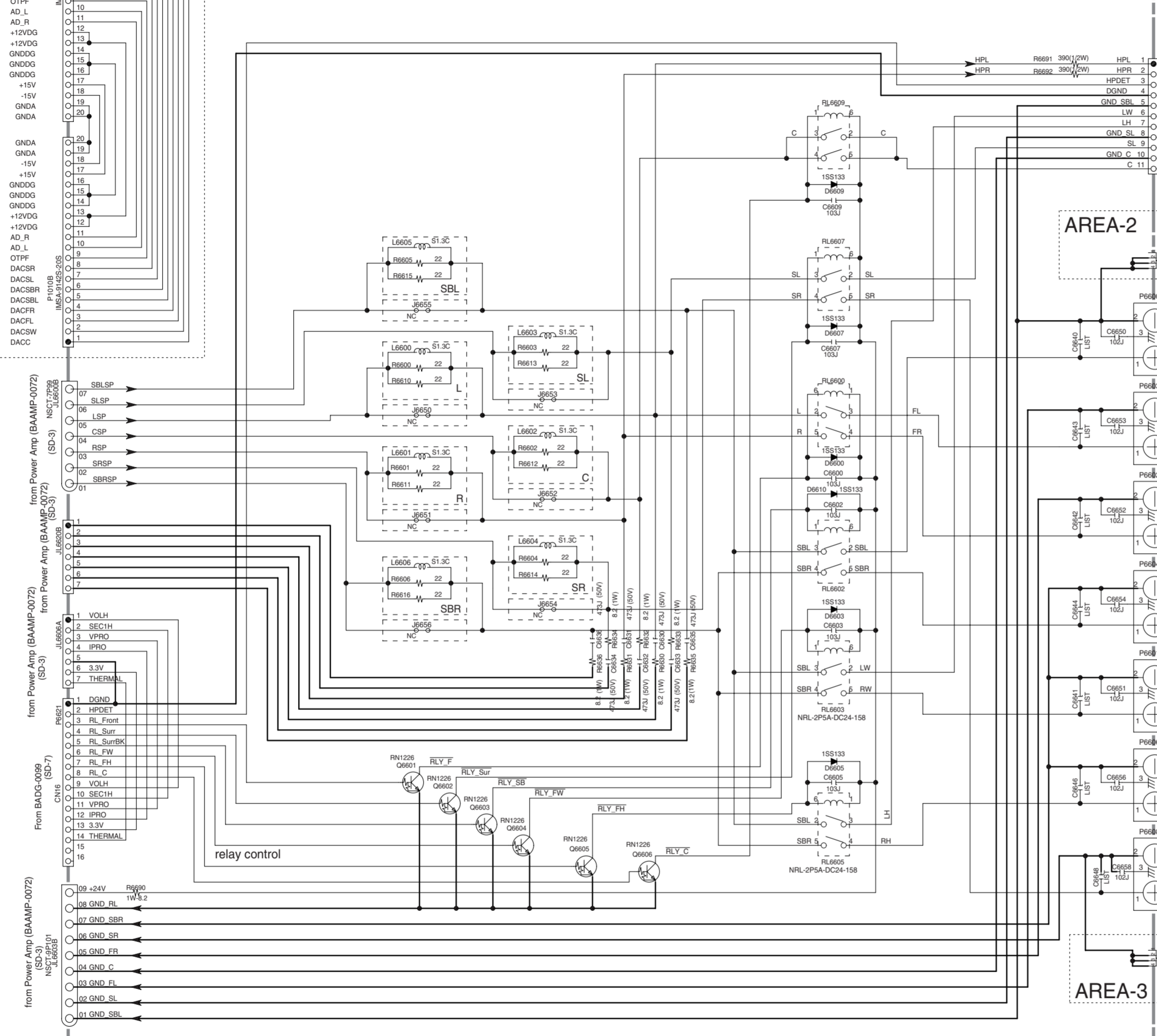

**U0022 SPEAKER TERMINAL-2 PC BOARD**  
BATRM-0085-1G/-1H

**AREA-4**

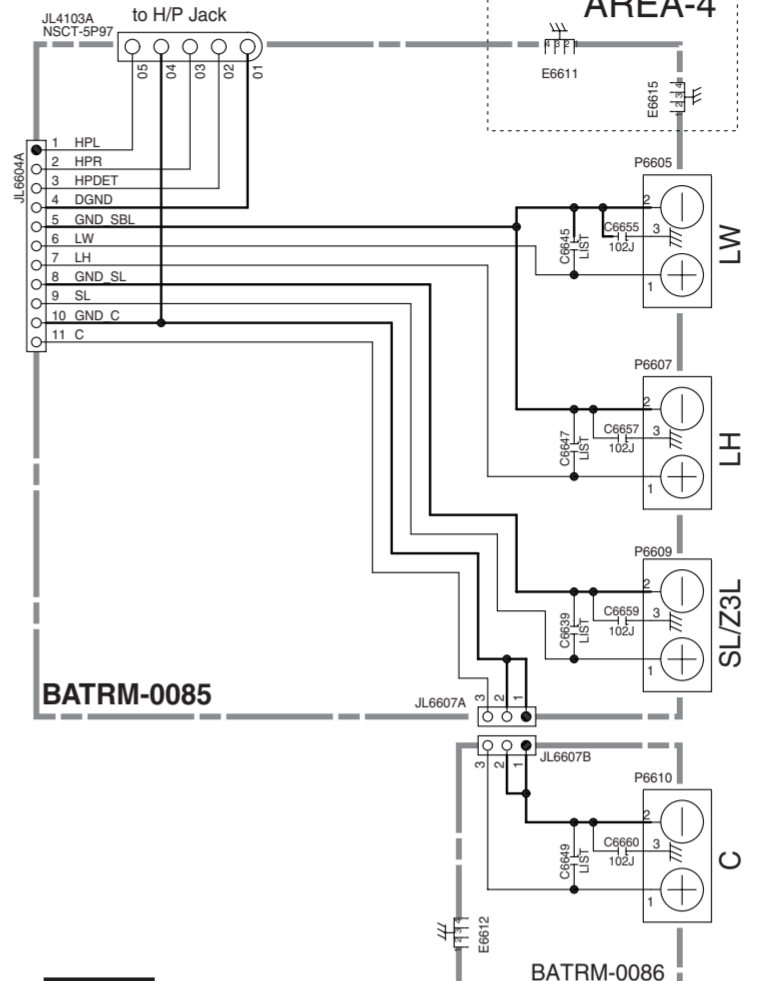

**U0021 PRIMARY POWER SUPPLY PC BOARD**  
BAPS-0084-1G/-1H

**U0023 CENTER SPEAKER TERMINAL PC BOARD**  
BATRM-0086-1G/-1H

**AREA-5**

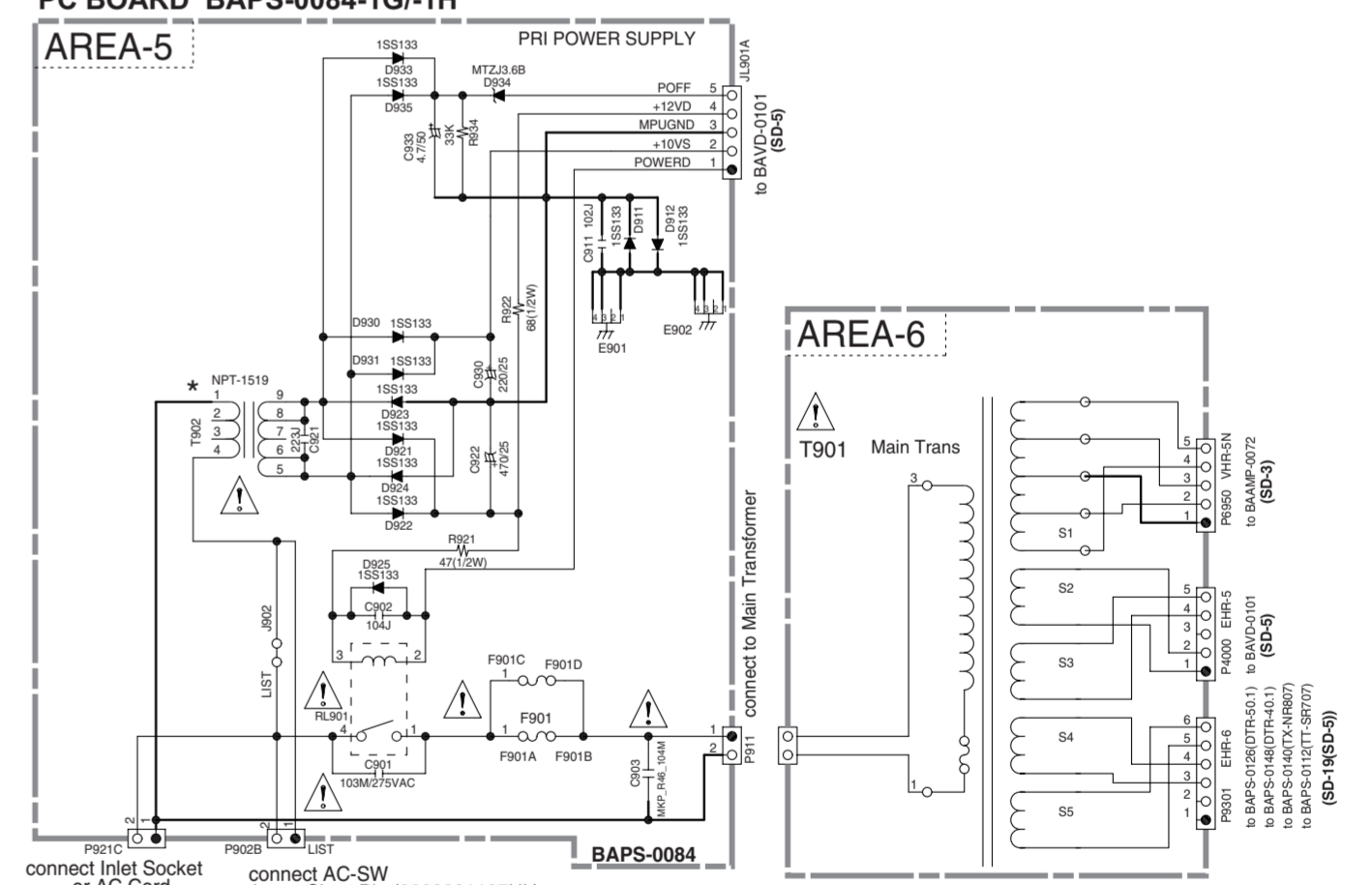

TYPE	T7	A7	T8	A8
D	NC	NC	NC	NC
J	NC	NC	NC	NC
M	472J	---	472J	---

CODE	MODEL
T7	TX-SR-707, DTR-40.1
A7	TX-SA707
T8	TX-NR807, DTR-50.1
A8	TX-NA807

**< CAUTION >**  
DHC-40.1 use only AREA-1, 2, 3, 4, 5 & 6.

- NOTE**
- THE COMPONENTS IDENTIFIED BY MARK ARE CRITICAL FOR SAFETY. REPLACE ONLY WITH PART NUMBER SPECIFIED.
  - VOLTAGE (MEASURED WITH VOLTMETER) IS DC VOLTAGE. (NO INPUT SIGNAL)
  - ELECTROLYTIC CAPACITORS ( ) ARE IN uF/WV.
  - ALL CAPACITORS ARE IN pF/50WV UNLESS OTHERWISE NOTED.  
EX) 030 - 3pF 330 - 33pF 331 - 330pF 333 - 0.033uF
  - ALL RESISTORS ARE IN OHMS 1/4WATTS UNLESS OTHERWISE NOTED.
  - THE THICK LINES ON PC BOARD ARE THE PRINTING SIDE OF THE PARTS.
  - EX) - PRINTING SIDE
  - CIRCUIT IS SUBJECT TO CHANGE FOR IMPROVEMENT.

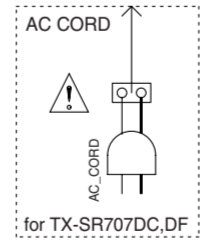

J902	TYPE	T7	A7	T8	A8	DHC-40.1
J902	TX-SR707, TX-SA707, DTR-40.1	Mount	---	---	---	---
	NR807, NA807, DTR-50.1	No mount	---	---	---	---
	DHC-40.1	Mount	---	---	---	---

P902B	TYPE	T7	A7	T8	A8	DHC-40.1
P902B	TX-SR707, TX-SA707, DTR-40.1	No mount	---	---	---	---
	TX-NR807, TX-NA807, DTR-50.1	Mount	---	---	---	---
	DHC-40.1	No mount	---	---	---	---

F901	TYPE	T7	A7	T8	A8	DHC-40.1
F901	D	10A 125V	---	12A 125V	---	5A 125V
	J	10A 125V	10A 125V	15A 125V	15A 125V	---
	M	T5.0AL250V	---	T6.3AL250V	---	---

T902	TYPE	T7	A7	T8	A8	DHC-40.1
T902	D	1520JQ	---	1520JQ	---	1520JQ
	J	---	1520JQ	---	1520JQ	---
	M	1520GQ	---	1520GQ	---	---

**CAUTION**

THIS SYMBOL, LOCATED NEAR THE FUSE INDICATES THAT THE FUSE USED IS SLOW OPERATING TYPE. FOR CONTINUED PROTECTION AGAINST FIRE HAZARD, REPLACE WITH SAME TYPE AND RATING INDICATED.

CE SYMBOLE INDIQUE QUE LE FUSIBLE UTILISE EST A LENT. E POUR UNE PROTECTION PERMANENTE, N'UTILISER QUE DES FUSIBLES DE MEME TYPE. CE DERNIER EST INDIQUE LA OU LE PRESENT SYMBOLE EST APPOSE.

**CAUTION**

FOR CONTINUED PROTECTION AGAINST FIRE HAZARD, REPLACE ONLY WITH FUSE OF SAME TYPE AND RATING INDICATED.

**ATTENTION**

AFIN D'ASSURER UNE PROTECTION PERMANENTE CONTRE LES RISQUES D'INCENDIE, REMPLACER UNIQUEMENT PAR UN FUSIBLE DE MEME TYPE ET CALIBRATION COMME INDIQUE.

SCHEMATIC DIAGRAM-5

U0032 VIDEO CIRCUIT PC BOARD (BAVD-0101-1K/1-L) (PART-9)

1  
2  
3  
4  
5  
6  
7  
8

BAVD-0101

Not used TO D Terminal PWB TO BAVD-0102 (Part 10 Terminal Section)

TO HDMI PWB (SD-8) TO BAHDM-0132 (Part 14 HDMI Section)

TO HDMI board (SD-9) JL8002A JL8002S JL200909H P2 5X3 L-20

TO DG PWB TO BACPU-0100 (Part 11 MICRON Section)

TO ASP PWB TO BAASP-0073 (Part 12 ASP Section)

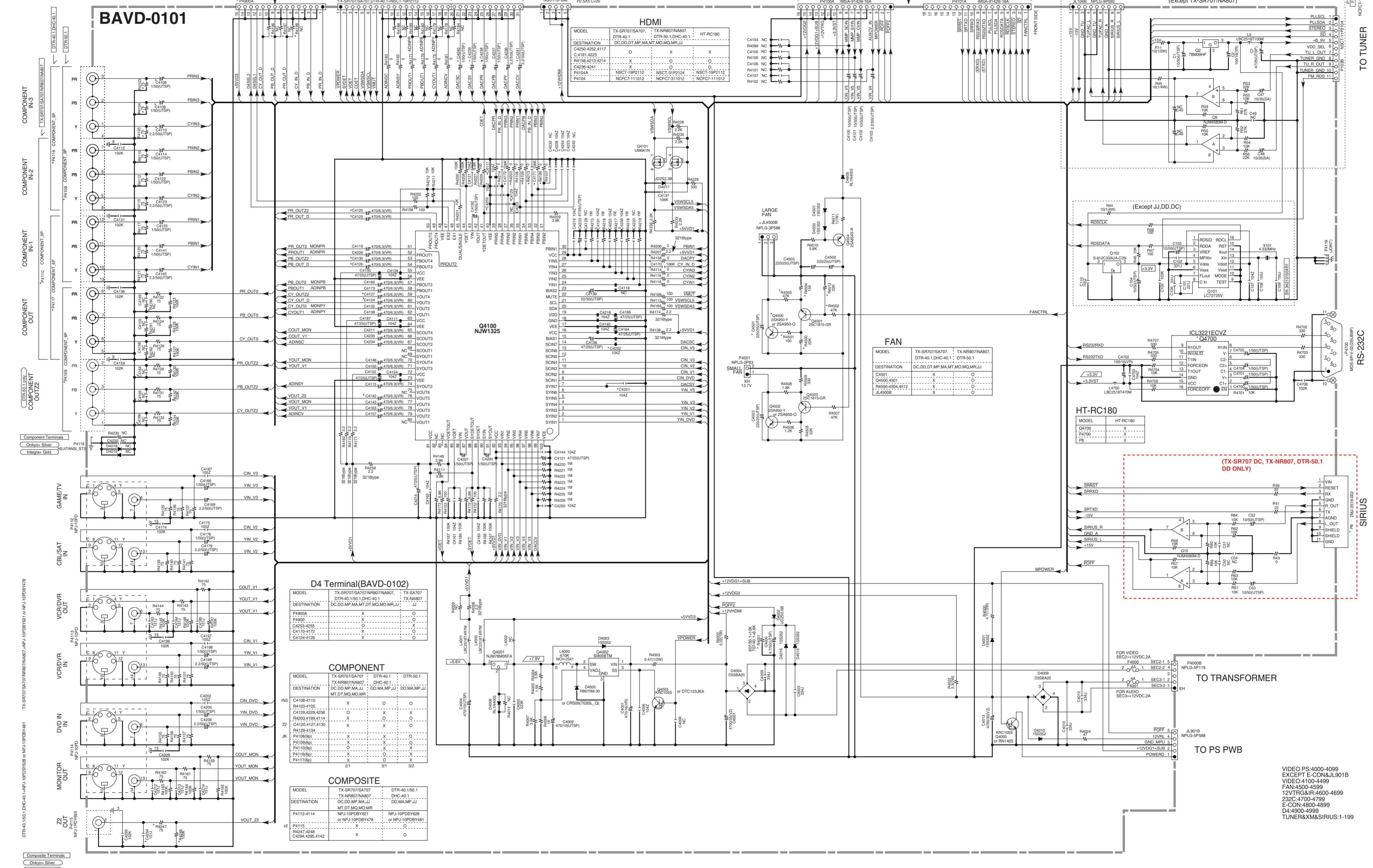

HDMI DESTINATION table with columns for TX-SR707/SA707, TX-NR807/NA807, DTR-40.1, DTR-50.1, and HT-RC180.

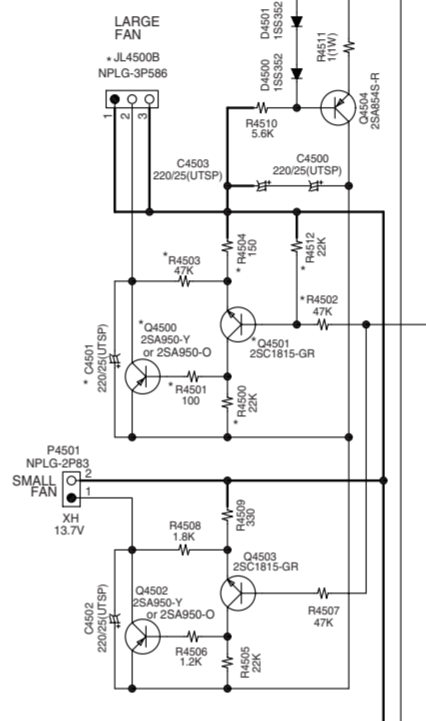

FAN DESTINATION table with columns for TX-SR707/SA707, TX-NR807/NA807, DTR-40.1, DTR-50.1, and HT-RC180.

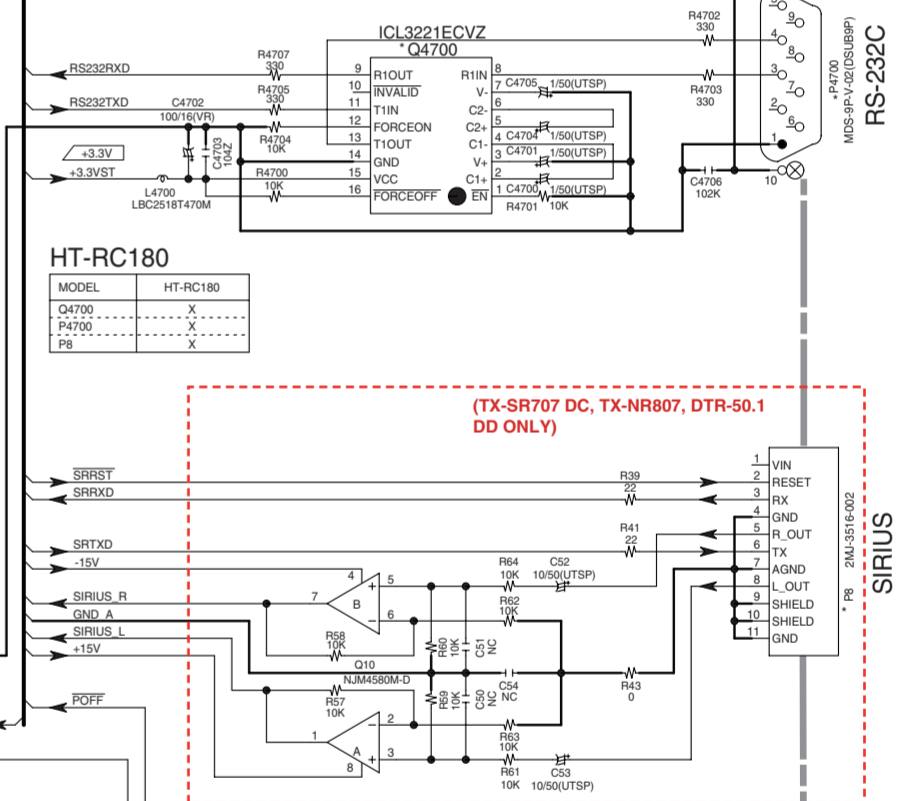
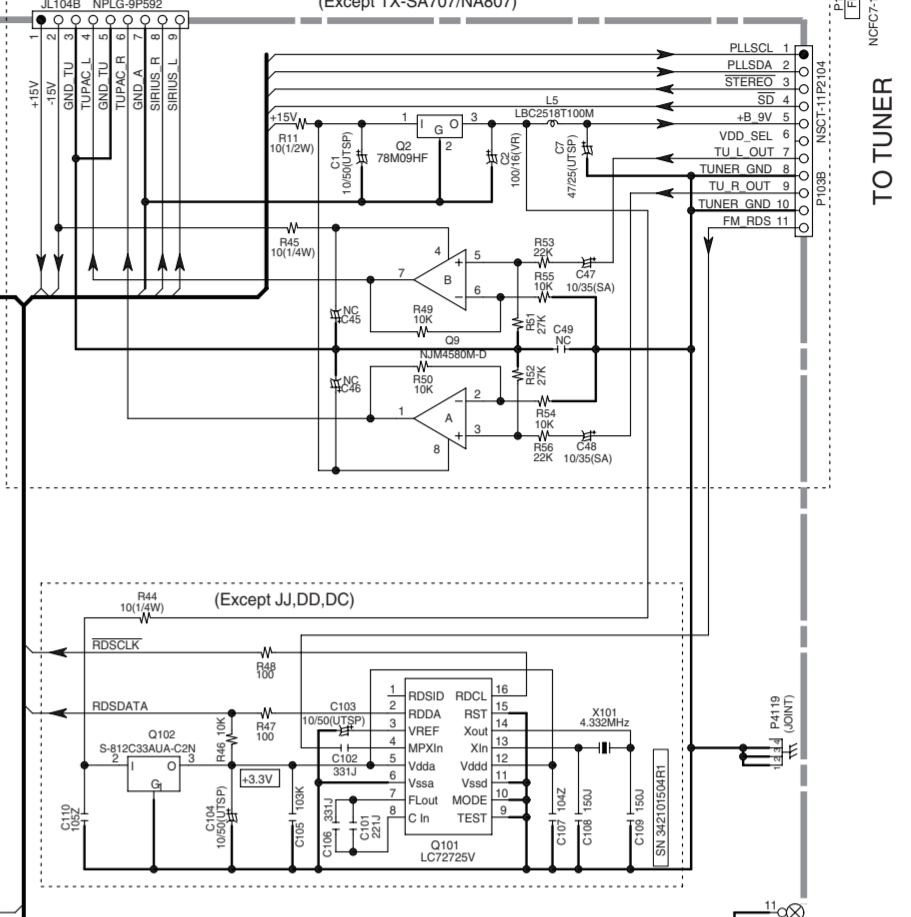

D4 Terminal (BAVD-0102) DESTINATION table with columns for TX-SR707/SA707, TX-NR807/NA807, DTR-40.1, DTR-50.1, and TX-NR807/NA807.

COMPONENT DESTINATION table with columns for TX-SR707/SA707, TX-NR807/NA807, DTR-40.1, DTR-50.1, and TX-NR807/NA807.

COMPOSITE DESTINATION table with columns for TX-SR707/SA707, TX-NR807/NA807, DTR-40.1, DTR-50.1, and TX-NR807/NA807.

VIDEO PS:4000-4099 EXCEPT E-CON&JL9018 VIDEO-0100-4499 FAN:4500-4599 12VTRG&IR:4600-4699 232C-4700-4799 E-CON:4800-4899 D4:4900-4999 TUNER&XM&SIRIUS:1-199

SCHEMATIC DIAGRAM-6

U0031 CPU CIRCUIT PC BOARD BACPU-0100-1K/1-L (PART-11)

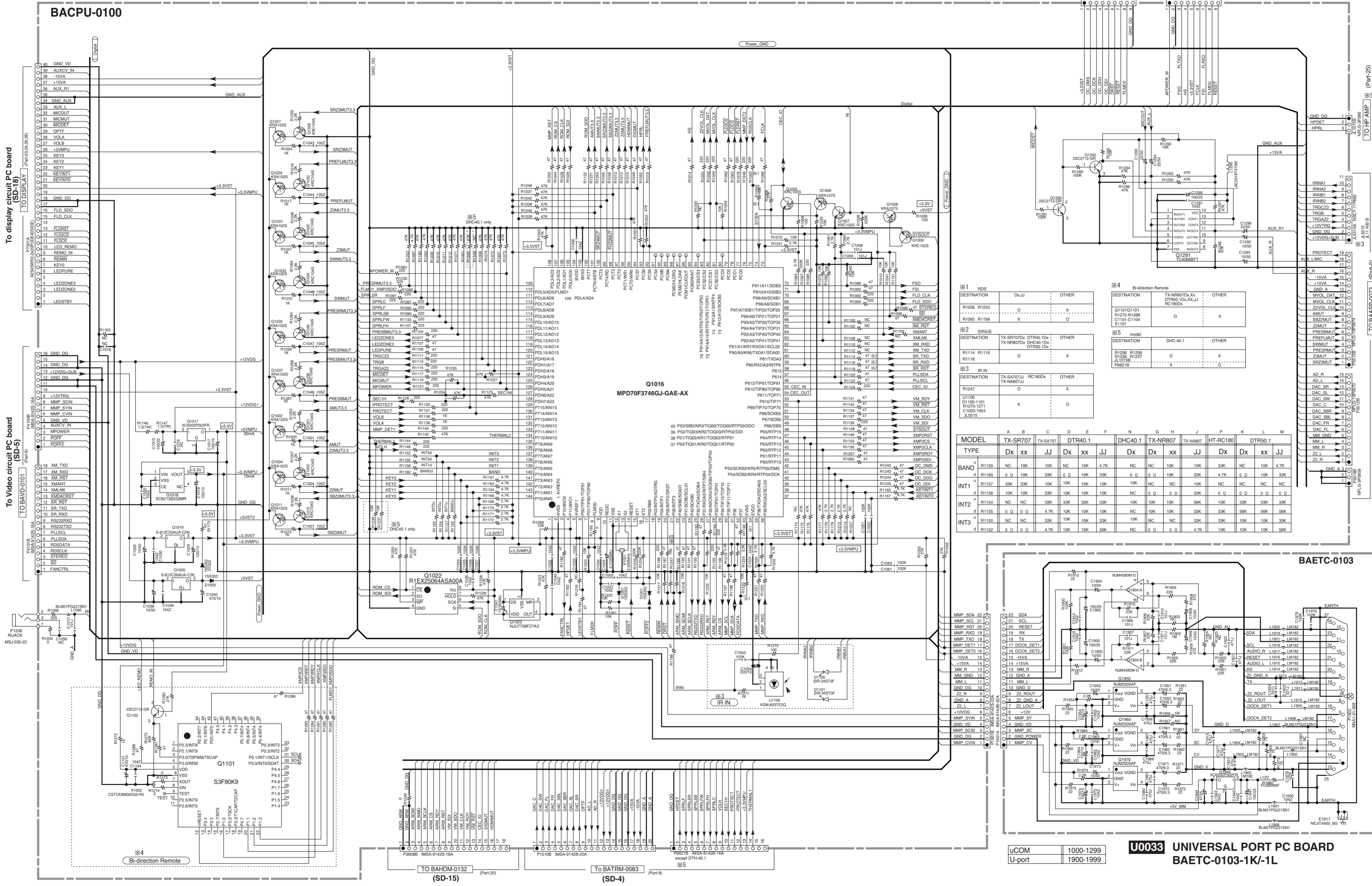

※1 RDS

DESTINATION	Dx, J	OTHER
R1088 R1220		X
R1065 R1199	X	

※2 SRRUS

DESTINATION	TX-SR707	DTR40.1Dx	OTHER
R1114 R1116 R1118		X	

※3 IR IN

DESTINATION	TX-SA707AJ	RC1800X	OTHER
R1247		X	

※4 Bi-direction Remote

DESTINATION	TX-NR807Dx, Xx	DTR40.1Dx, Xx	OTHER
Q1101 Q1101			X
C1101-C1104			X

※5 model

DESTINATION	DHC-40.1	OTHER
R1206 R1208 R1209 R1217		X

MODEL	A	B	C	D	E	F	G	H	J	K	L	M			
TYPE	Dx	xx	JJ	Dx	xx	JJ	Dx	Dx	xx	JJ	Dx	xx	JJ		
BAND	R1159	NC	10K	10K	NC	10K	4.7K	NC	NC	10K	10K	33K	NC	10K	4.7K
INT1	R1160	0	0	10K	33K	0	0	10K	33K	0	0	0	0	0	0
INT2	R1154	NC	NC	33K	33K	33K	33K	10K	10K	10K	56K	10K	33K	33K	33K
INT3	R1155	0	0	0	4.7K	10K	10K	10K	NC	10K	10K	33K	33K	56K	56K
	R1150	NC	NC	33K	10K	10K	33K	10K	NC	NC	33K	33K	10K	10K	33K
	R1152	0	0	0	4.7K	10K	10K	56K	NC	0	0	0	4.7K	10K	10K

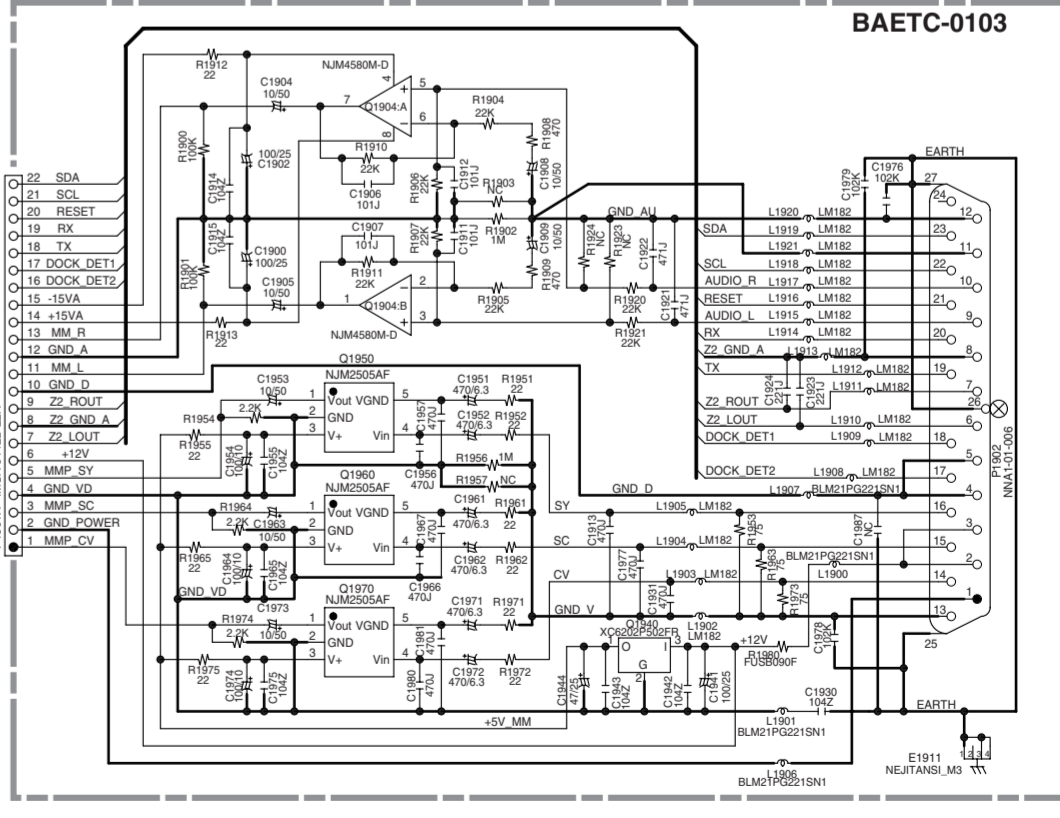

uCOM 1000-1299  
U-port 1900-1999

U0033 UNIVERSAL PORT PC BOARD BAETC-0103-1K/1-L



SCHEMATIC-DIAGRAM-7

U0030 DAC/ DIR CIRCUIT PC BOARD-7  
BADG-0099-1K/1L (PART-12)

BADG-0099

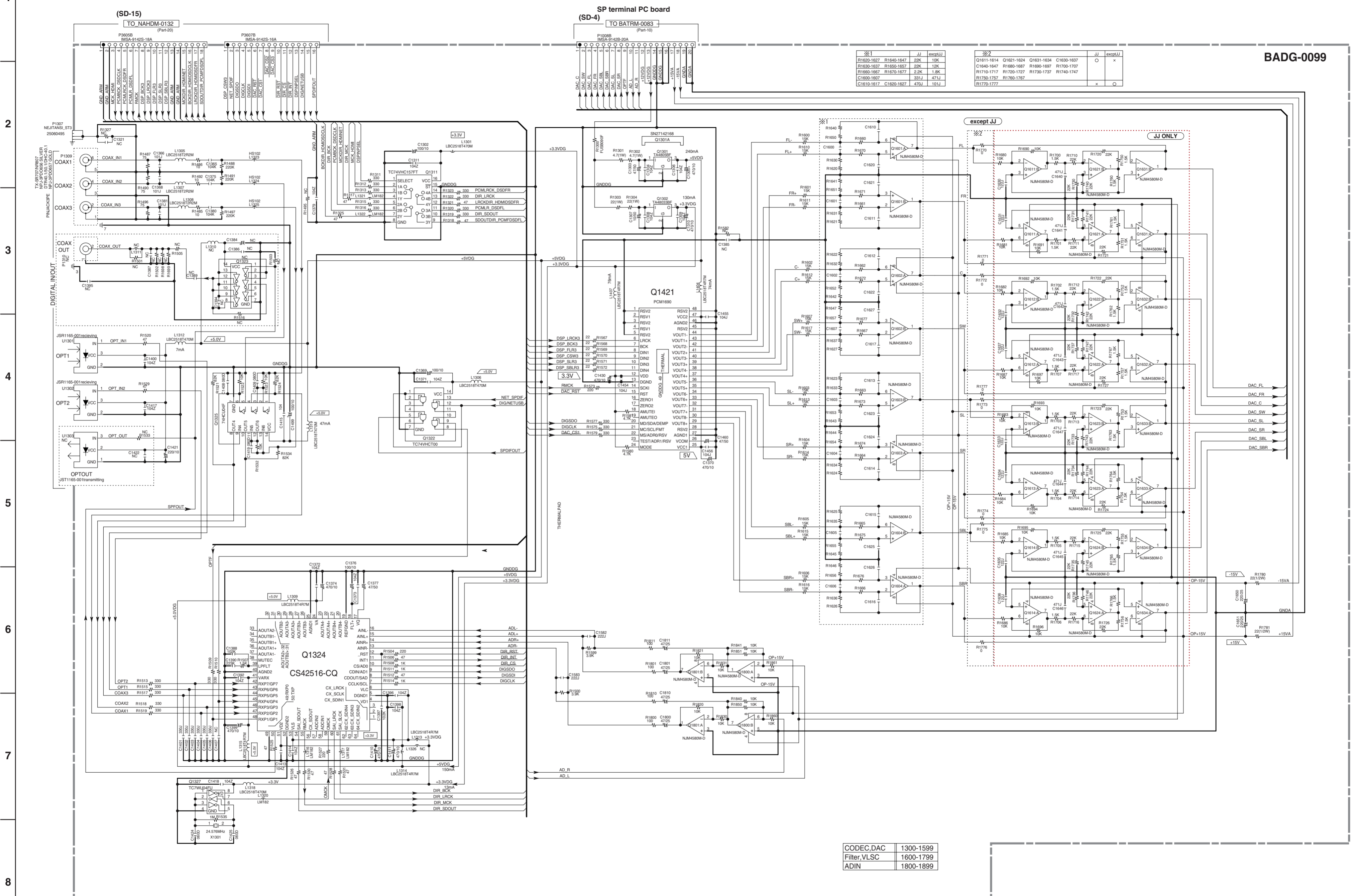

CODEC, DAC	1300-1599
Filter, VLSC	1600-1799
ADIN	1800-1899

*1		JJ	except JJ
R1620-1627	R1640-1647	22K	10K
R1630-1637	R1650-1657	22K	10K
R1660-1667	R1670-1677	2.2K	1.0K
C1600-1607	C1610-1617	331J	471J
C1610-1617	C1620-1627	470J	101J

*2		JJ	except JJ
Q1611-1614	Q1621-1624	Q1631-1634	C1630-1637
C1640-1647	R1690-1697	R1680-1687	R1700-1707
R1710-1717	R1720-1727	R1730-1737	R1740-1747
R1750-1757	R1760-1767		
R1770-1777			

\*1 except JJ

JJ ONLY

SCHEMATIC-DIAGRAM-8

U005 HDMI CIRCUIT PC BOARD-1  
BAHDM-0132-1E  
HDMI IN/ HDMI RX/ HDMI TX SECTION  
(PART-13)

1  
2  
3  
4  
5  
6  
7  
8

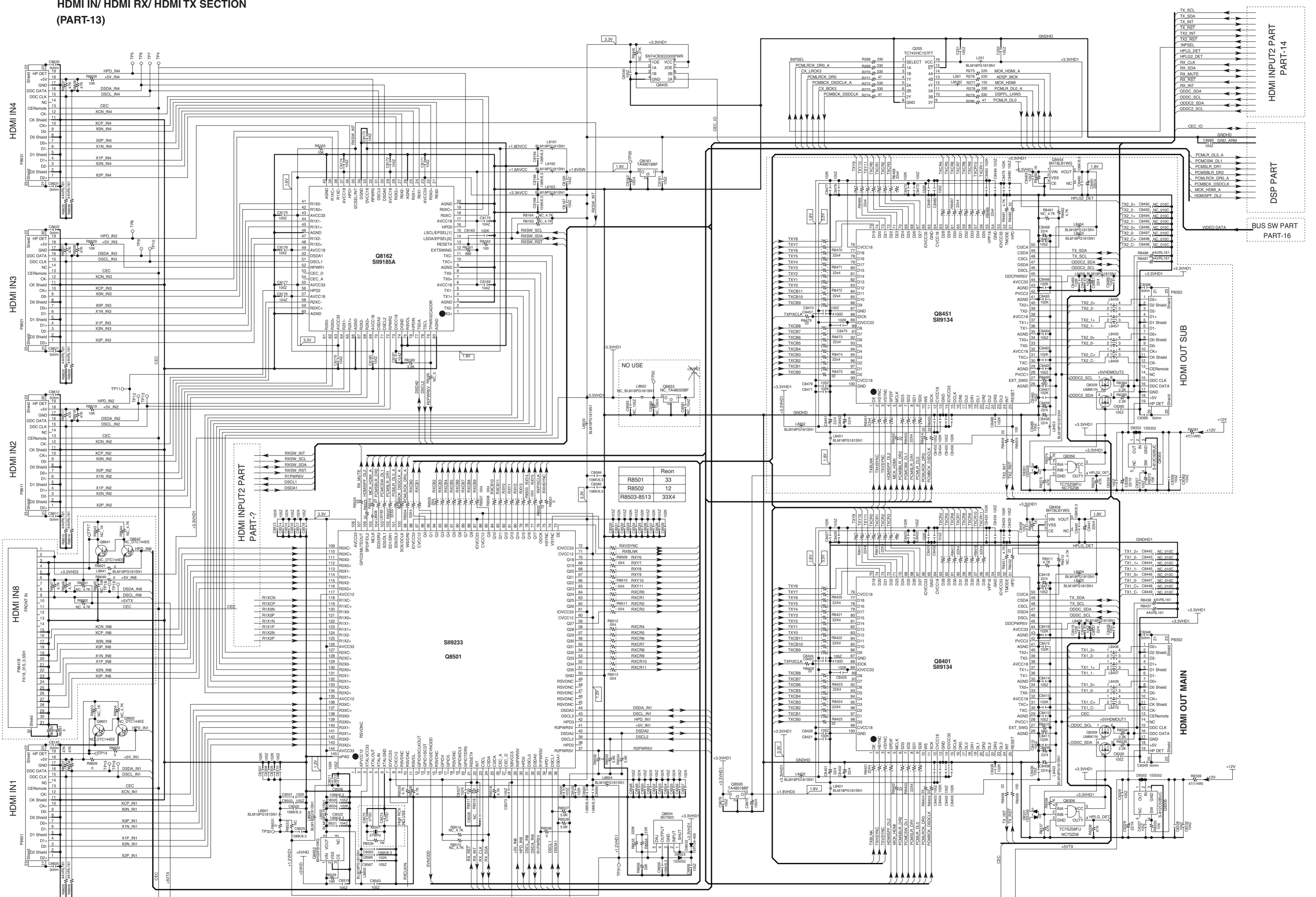

Reon	
R8501	33
R8502	12
R8503-8513	33X4

HDMI INPUT2 PART  
PART-14

DSP PART

BUS SW PART  
PART-16

HDMI OUT SUB

HDMI OUT MAIN

SCHEMATIC DIAGRAM-9

U005 HDMI CIRCUIT PC BOARD-2 BAHDM-0132-1E (PART-14) HDMI IN/ ENCODER/ POWER SUPPLY SECTION

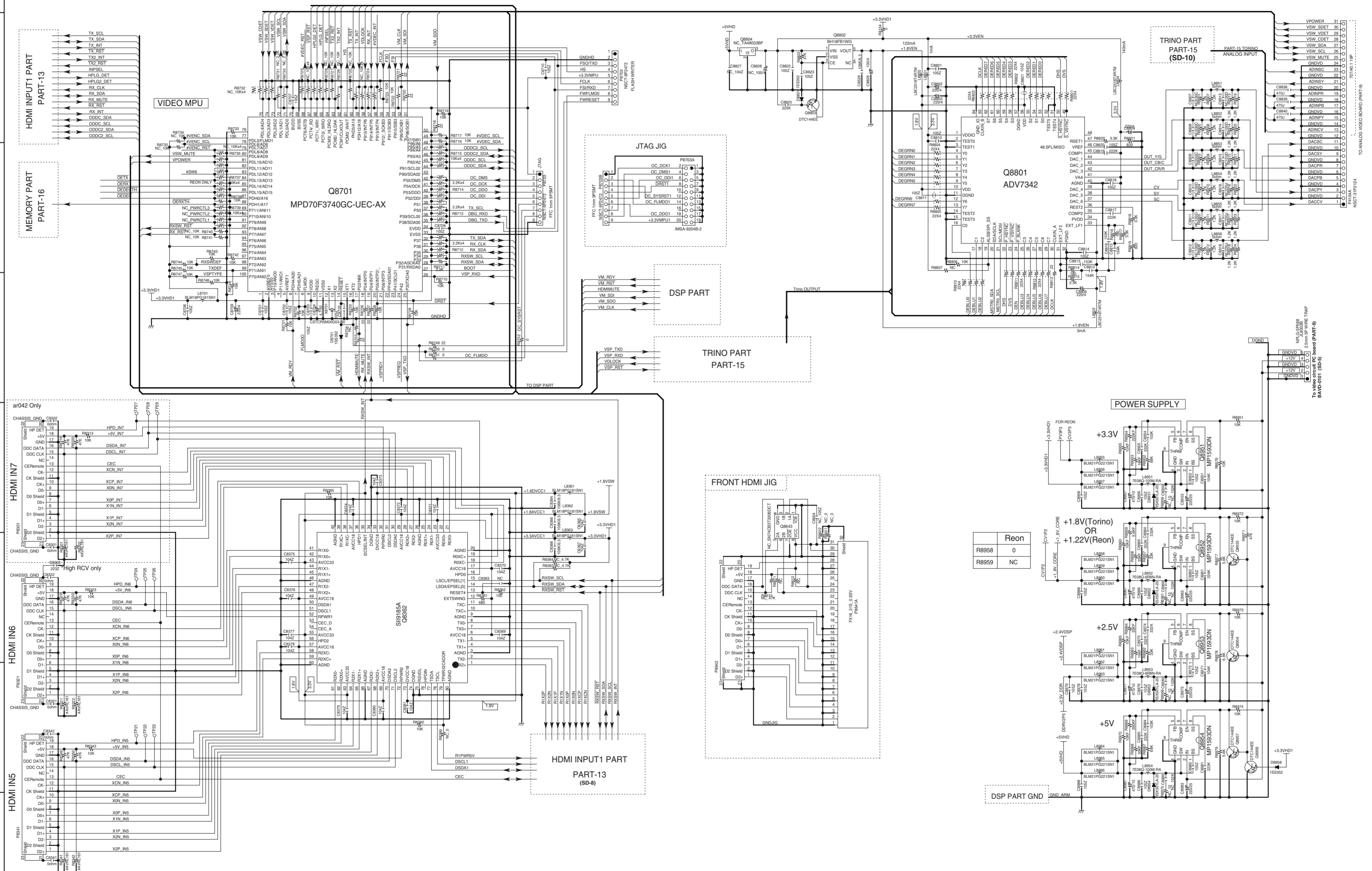

SCHEMATIC DIAGRAM-10

U005 HDMI CIRCUIT PC BOARD-3 BAHDM-0132-1E (PART-15) TRINO SECTION

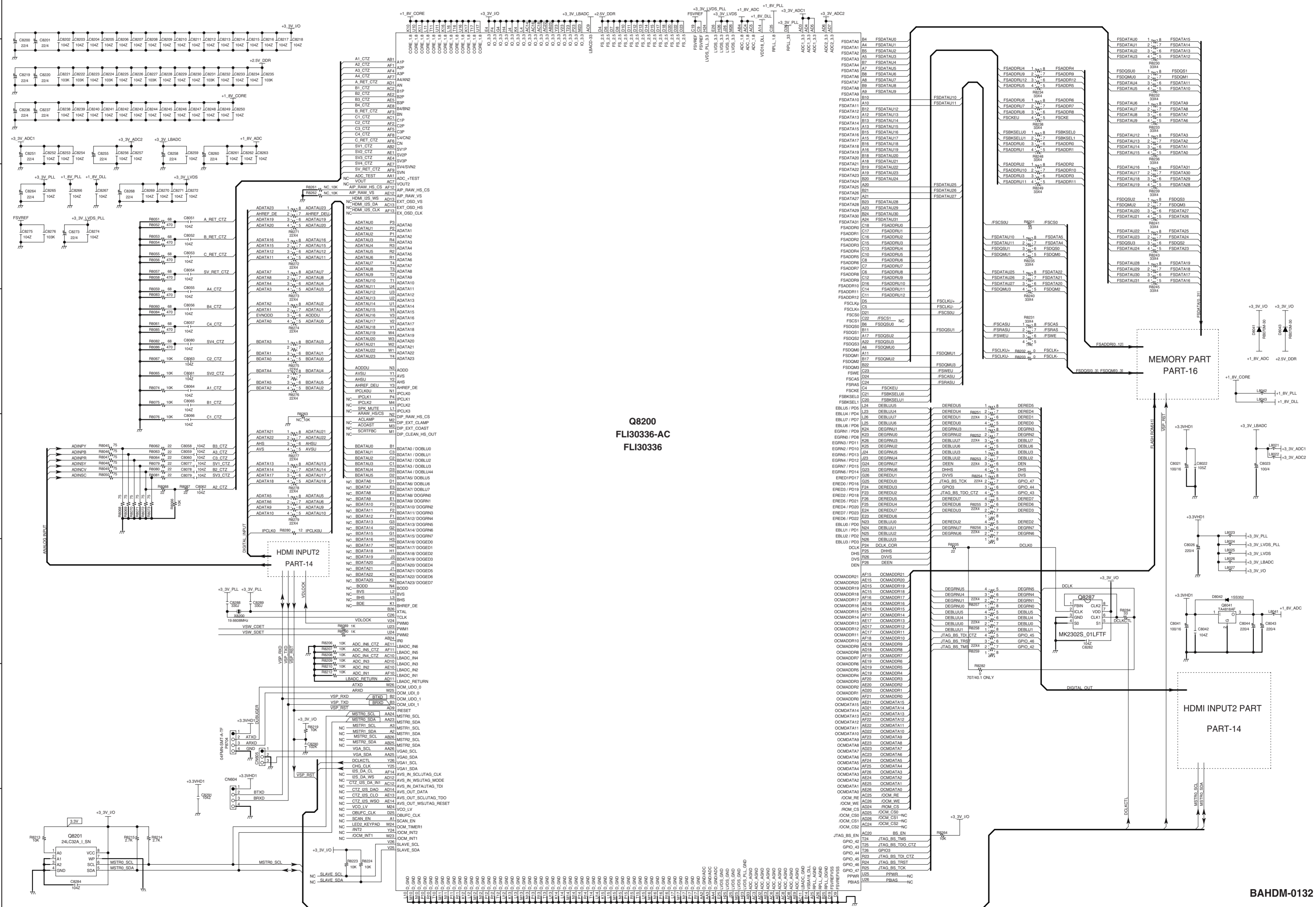

Q8200 FLI30336-AC FLI30336

MEMORY PART PART-16

HDMI INPUT2 PART PART-14

A B C D E F G H

SCHEMATIC DIAGRAM-11

U005 HDMI CIRCUIT PC BOARD-4  
BAHDM-0132-1E  
(PART-16) TRINO BOARD MEMORY SECTION

1

2

3

4

5

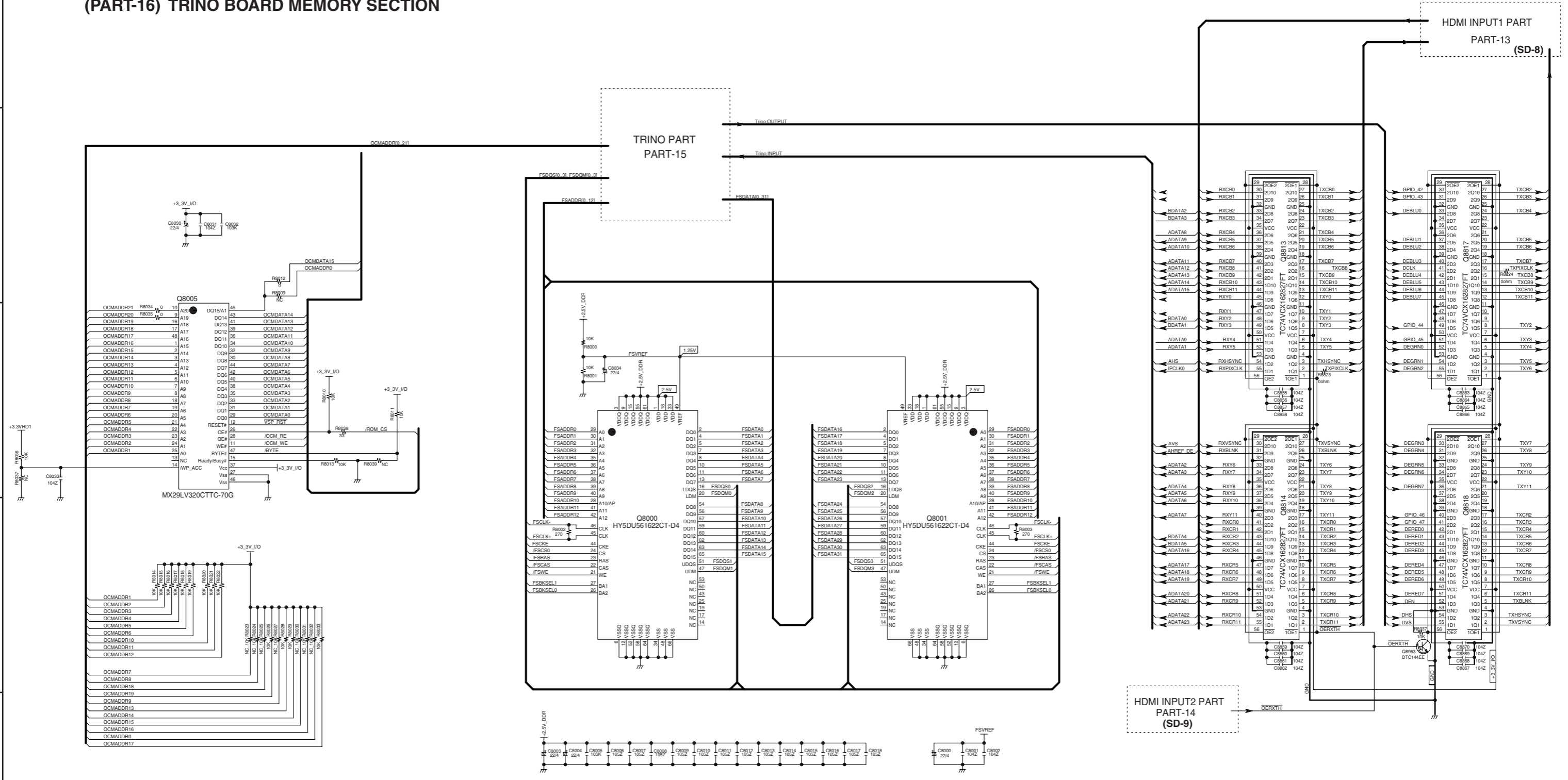

SCHEMATIC DIAGRAM-12

U005 HDMI CIRCUIT PC BOARD-5 BAHDM-0132-1E (PART-17) NET/ USB SECTION

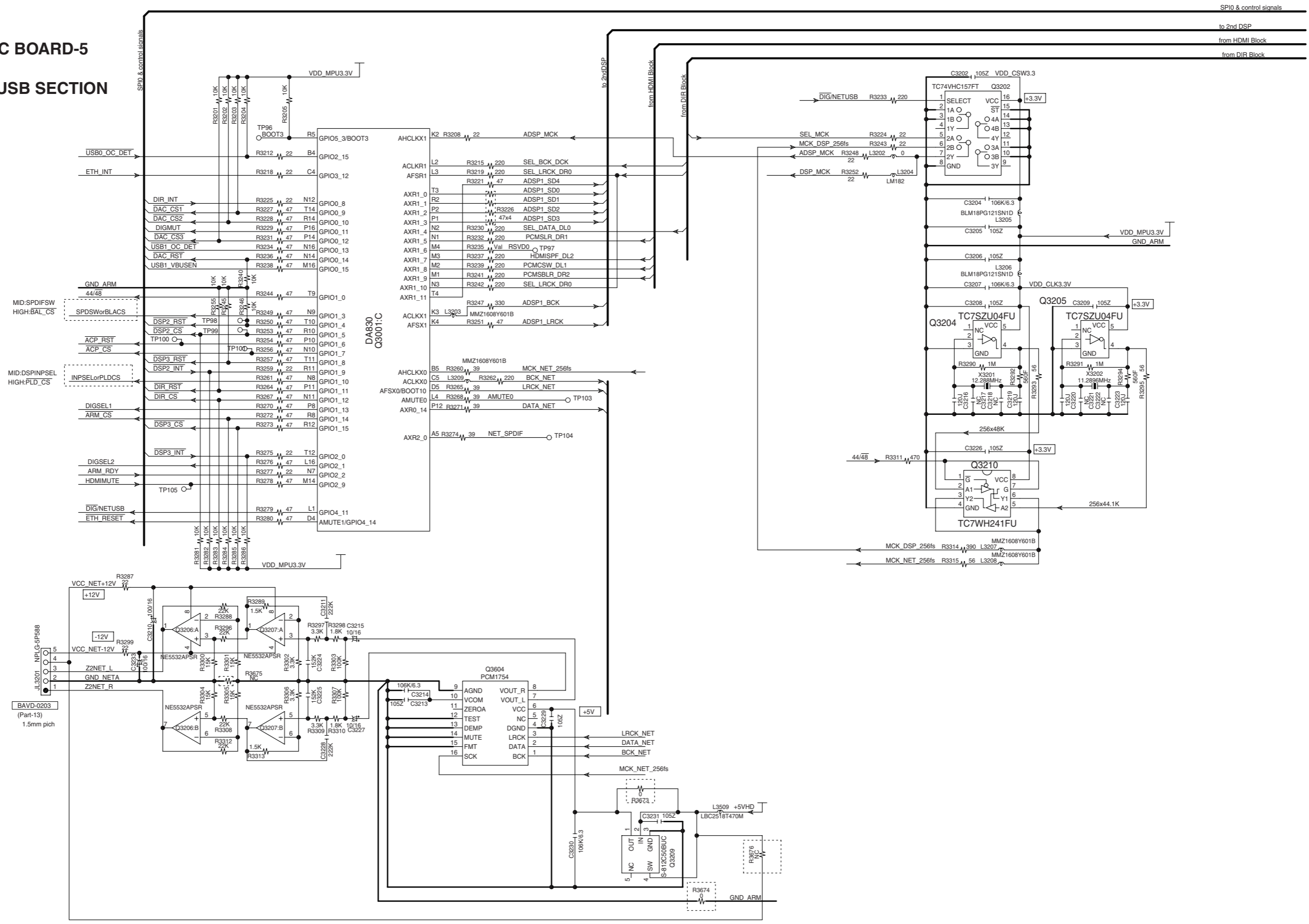

1  
2  
3  
4  
5

SPI0 & control signals  
to 2nd DSP  
from HDMI Block  
from DIR Block

BAVD-0203 (Part-13) 1.5mm pitch

# SCHEMATIC DIAGRAM-13

U005

## HDMI CIRCUIT PC BOARD-6 BAHDM-0132-1E (PART-18) NET/ USB POWER SECTION

R3115 or R3116	BOOT2
R3111 or R3112	BOOT5
R3109 or R3110	BOOT6
R3107 or R3108	BOOT7

Boot Opt.		NAND	UART1	SPI0
BOOT7		L	H	L
BOOT1		L	H	L
BOOT0		L	H	L
BOOT3		L	H	L
BOOT2		L	H	L

BOOT3 is always pulled up.

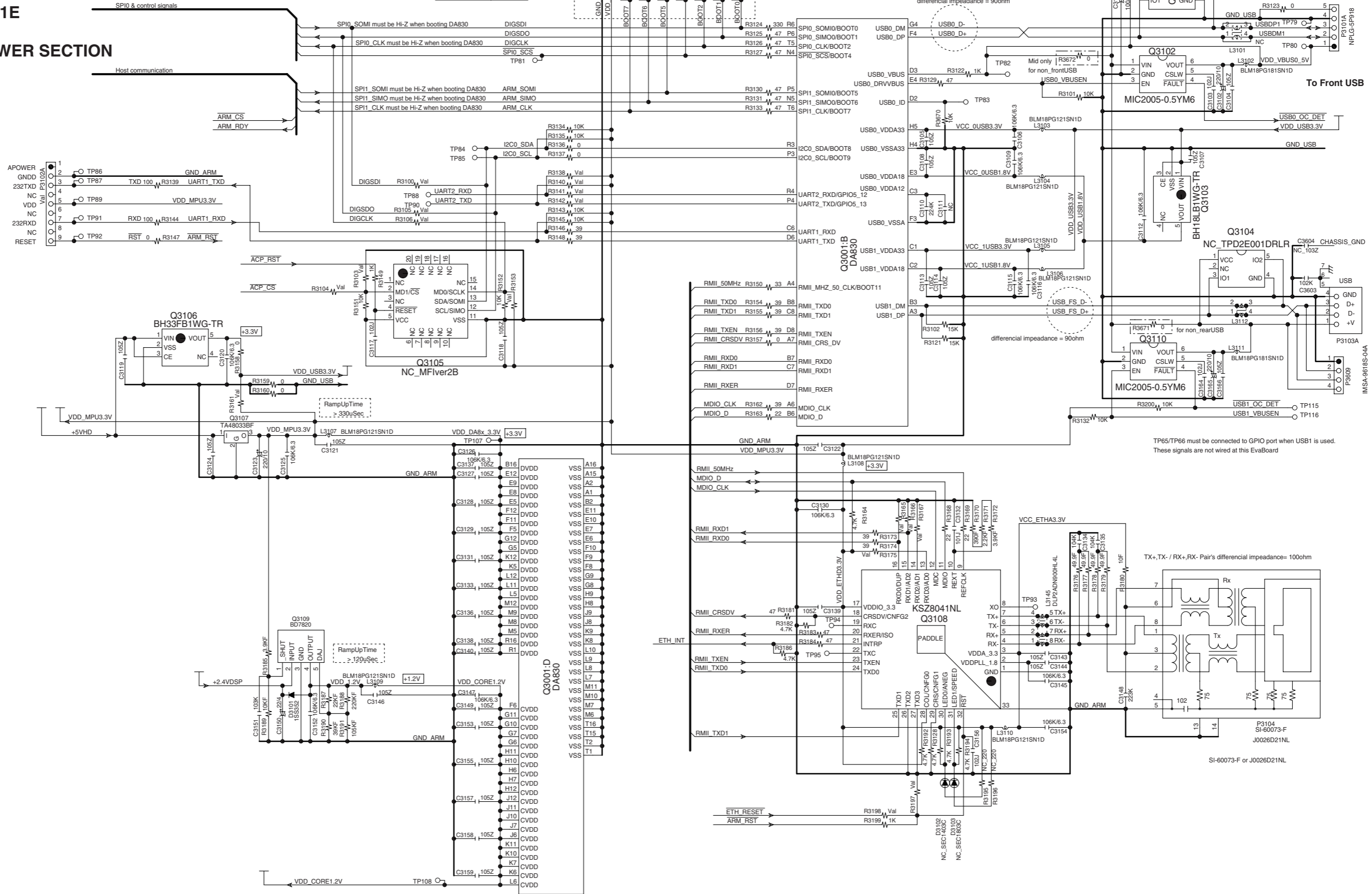

1

2

3

4

5

To Front USB

TP5/TP66 must be connected to GPIO port when USB1 is used. These signals are not wired at this EvaBoard

TP5/TP66 must be connected to GPIO port when USB1 is used. These signals are not wired at this EvaBoard

TX+,TX- / RX+,RX- Pair's differential impedance=100ohm

SI-60073-F or J0026D21NL

MSA-9618S-04A

SCHEMATIC DIAGRAM-14

U005 HDMI CIRCUIT PC BOARD-7 BAHDM-0132-1E (PART-19) DSP MEMORY SECTION

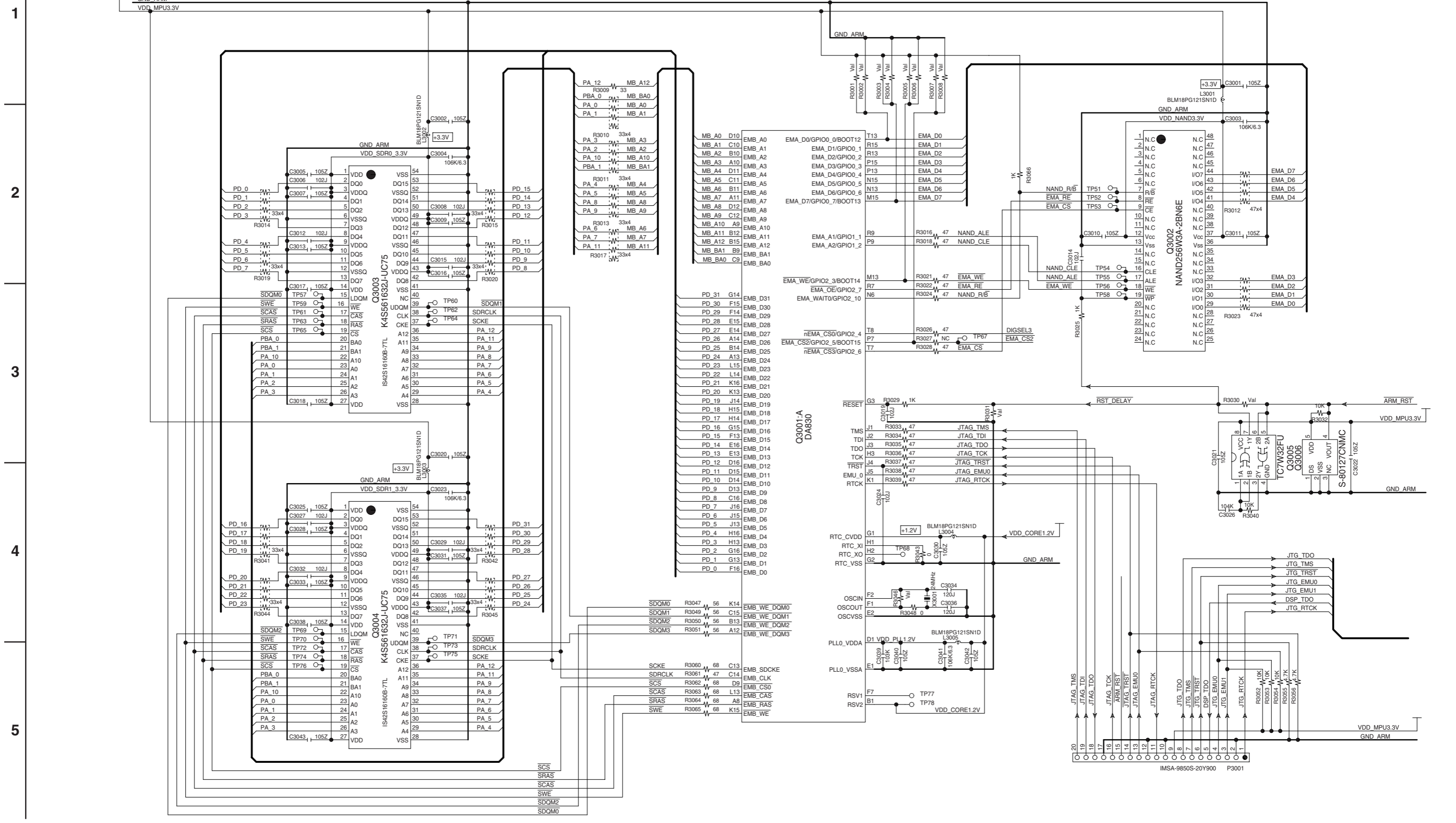



A B C D E F G H

SCHEMATIC DIAGRAM-15

U005 HDMI CIRCUIT PC BOARD-8  
BAHDM-0132-1E  
(PART-20) DSP CONNECT SECTION

1

2

3

4

5

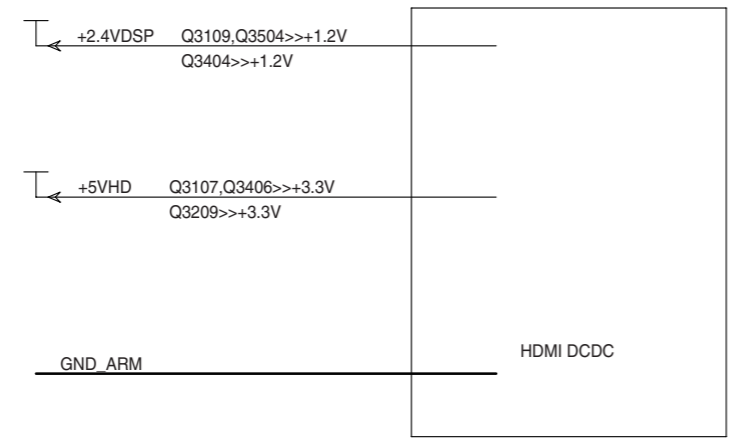
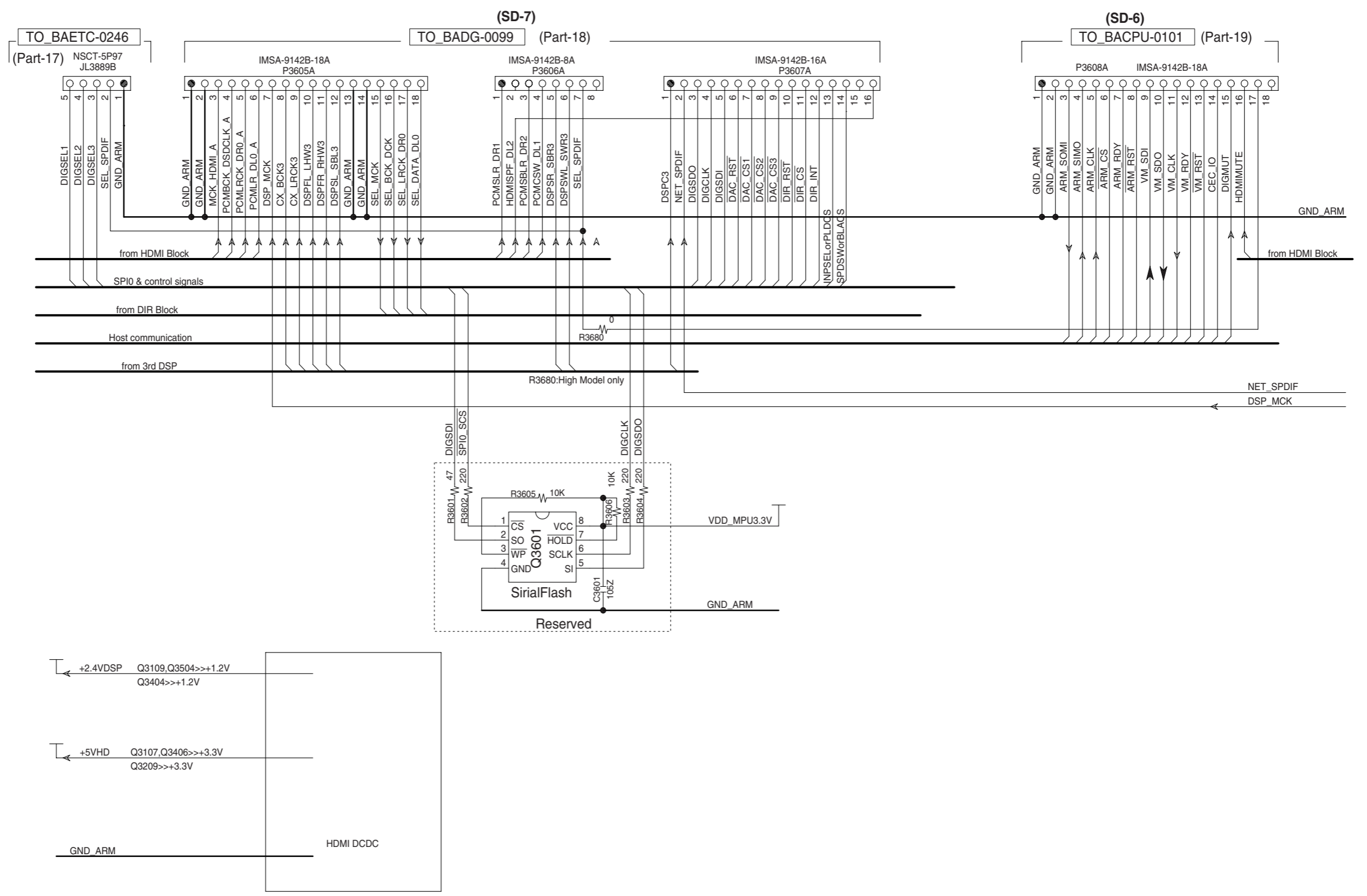

A B C D E F G H

SCHEMATIC DIAGRAM-16 U005 HDMI CIRCUIT PC BOARD-9 BAHDM-0132-1E (PART-21) DSP 2ND SECTION

1

2

3

4

5

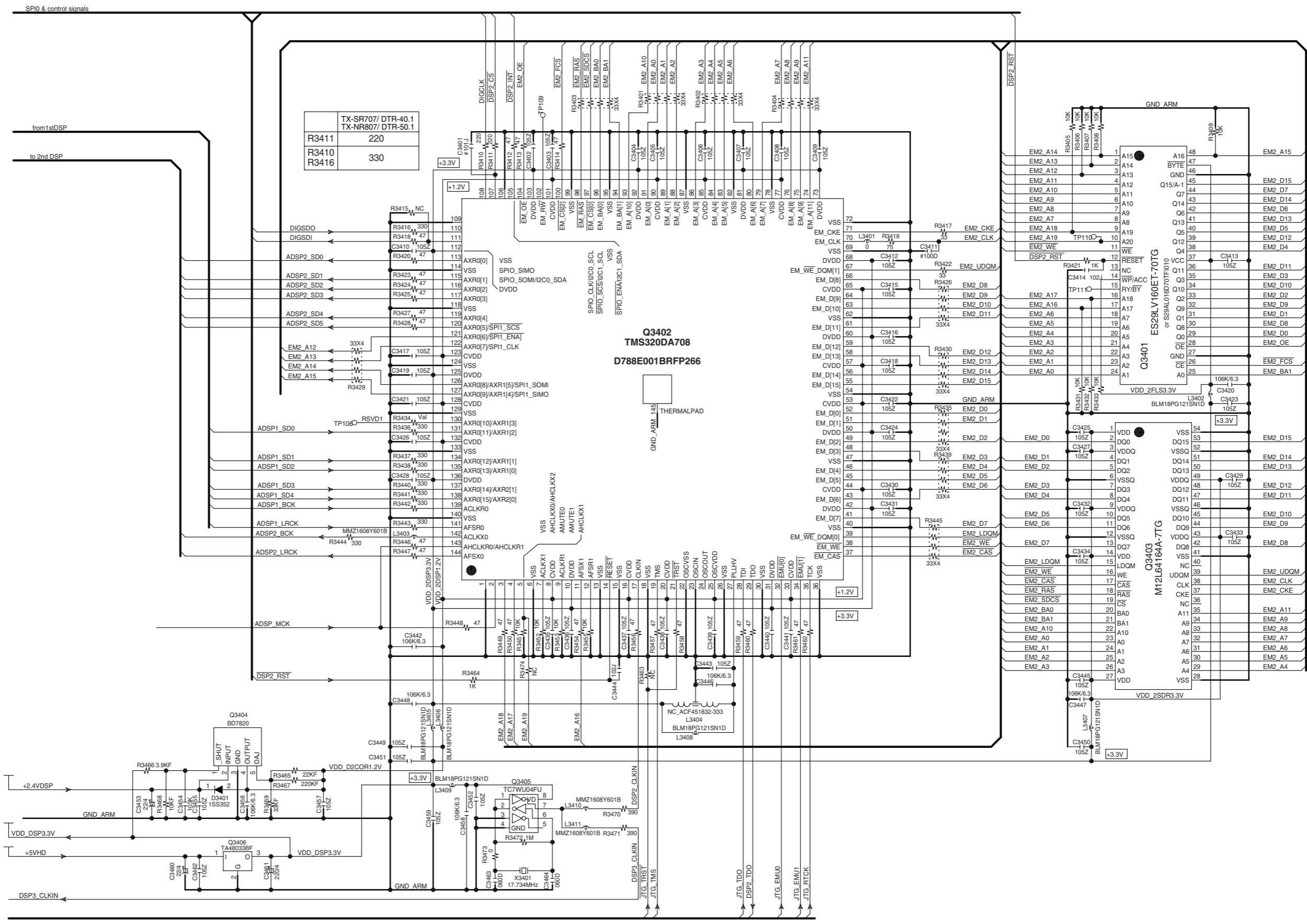

A B C D E F G H

SCHEMATIC DIAGRAM-17

U005 HDMI CIRCUIT PC BOARD-10  
BAHDM-0132-1E  
(PART-22) DSP 3RD SECTION

1

2

3

4

5

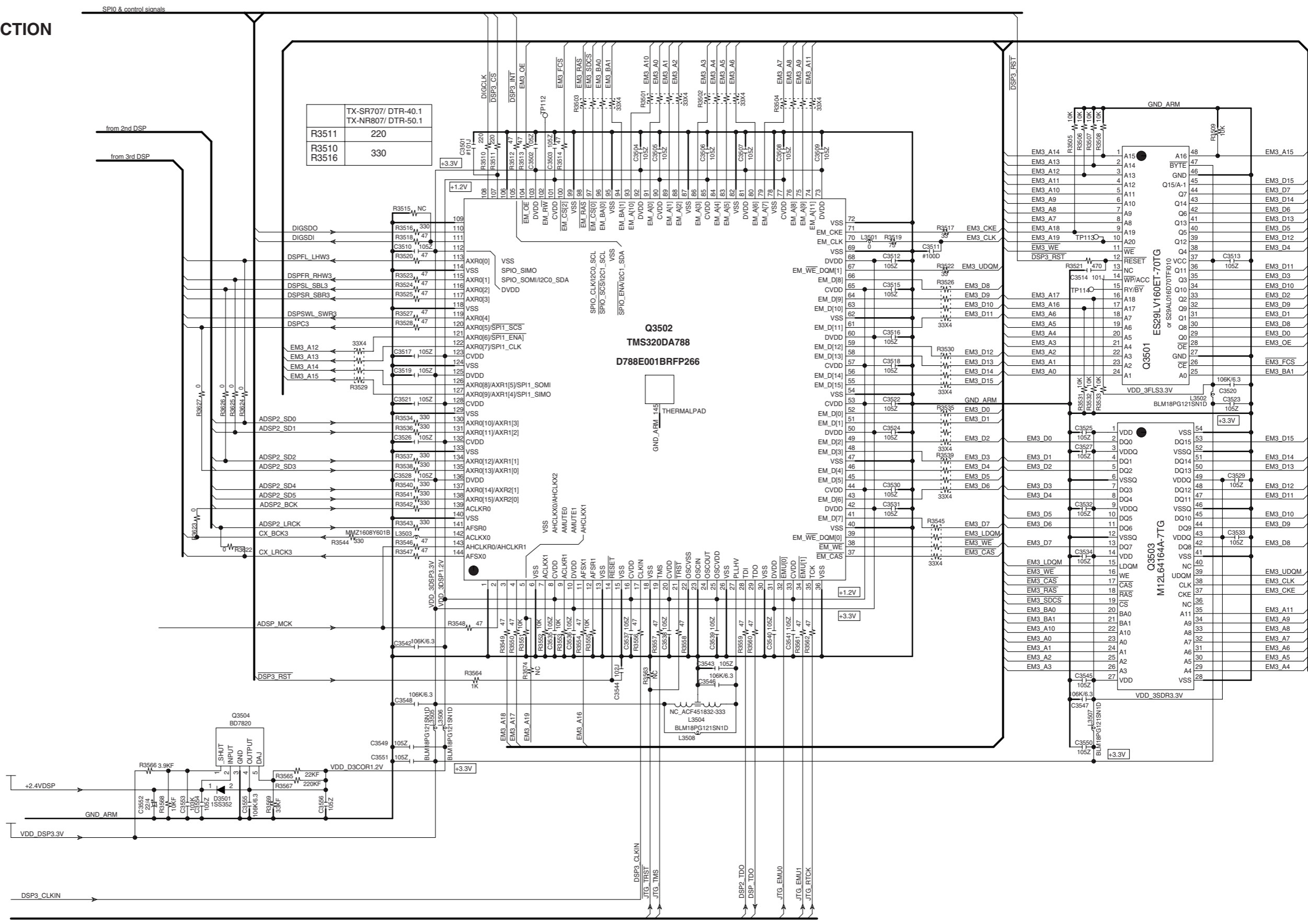

Q3502  
TMS320DA788  
D788E001BRFP266

Q3503  
M12L64164A-7TG

Q3504  
BD7820

BLM18PG121SN1D  
L3504

BLM18PG121SN1D  
L3506

# SCHEMATIC DIAGRAM-18

**U0040**  
**DISPLAY CIRCUIT PC BOARD**  
**BADIS-0121-1A (-1)**  
**(PART-28)**  
 DISP(TX DISP stage) SECTION

1

2

3

4

5

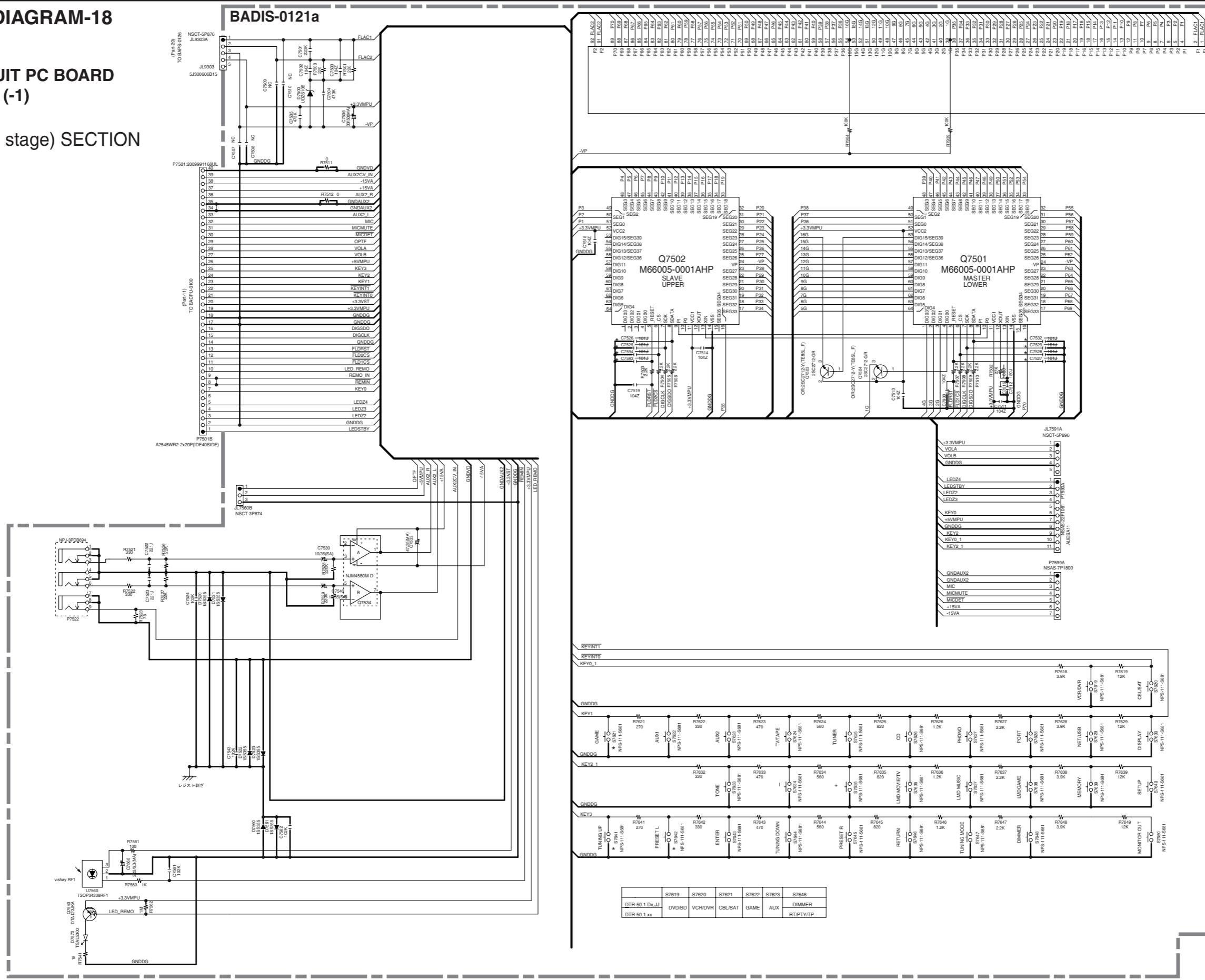

Q7500  
 HNA-16SL05T  
 Q7500A  
 FL HOLDER

S7619	S7620	S7621	S7622	S7623	S7648
DTR-50.1 D <sub>x</sub> L <sub>J</sub>	DVD/BD	VCR/DVR	CBL/SAT	GAME	AUX
DTR-50.1 xx					DIMMER RT/PTY/TP

SCHEMATIC DIAGRAM-19

**U0040**  
**DISPLAY CIRCUIT PC BOARD**  
**BADIS-0121-1A (-2)**  
**(PART-29)**  
**DISP(TX DISP stage) SECTION**

**U0041** **STANDBY SWITCH PC BOARD** **BASW-0122-1A**

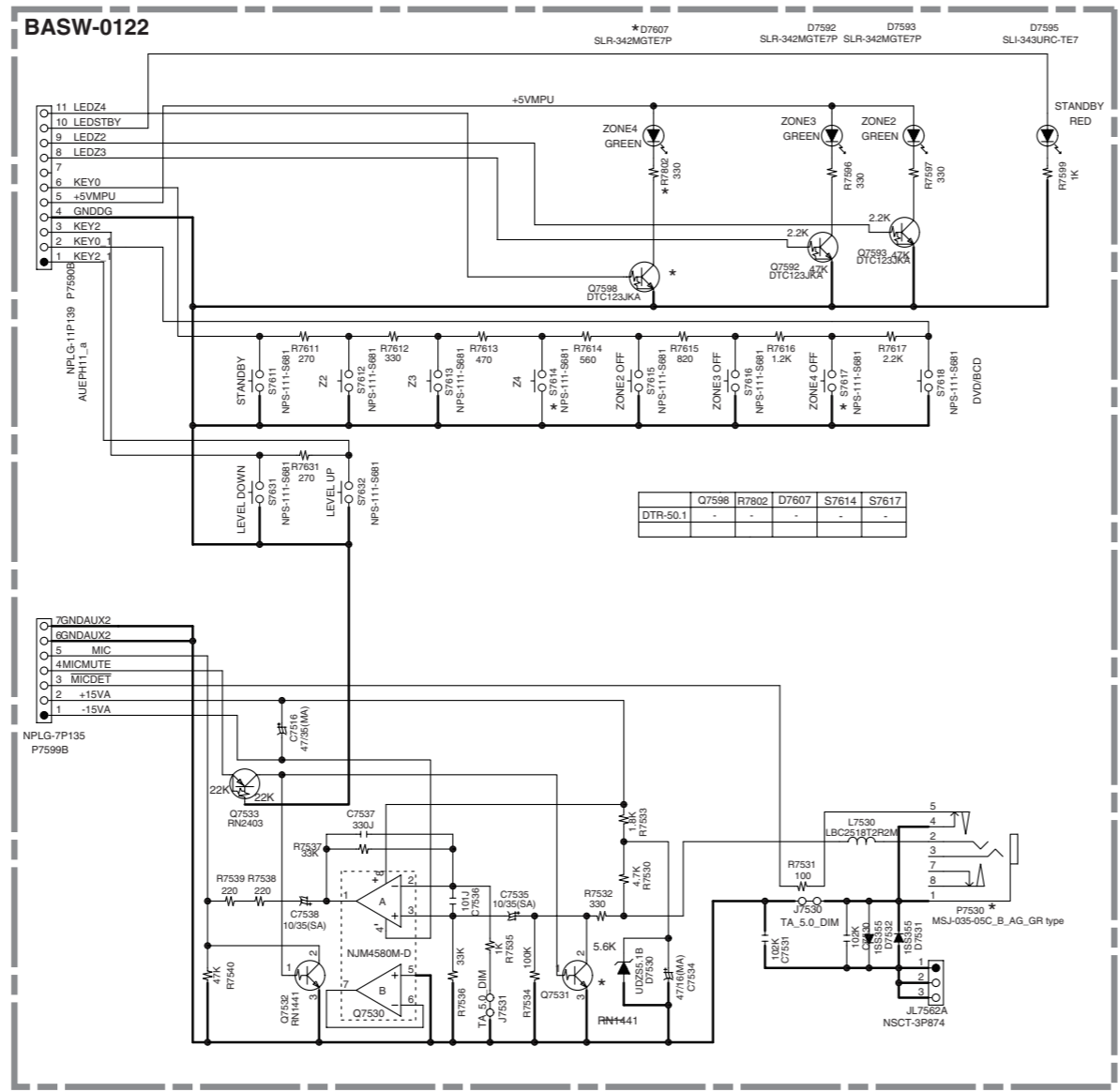

**U0042** **HEADPHONE TERMINAL PC BOARD** **BAETC-0123-1A**

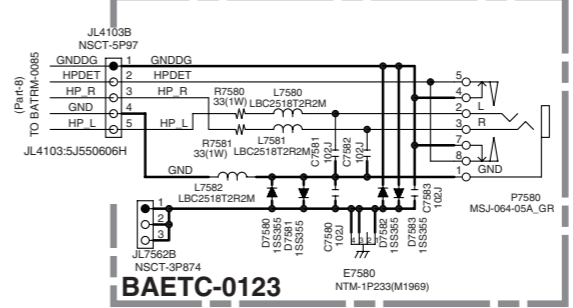

**U0044** **VOLUME PC BOARD** **BAETC-0125-1A**

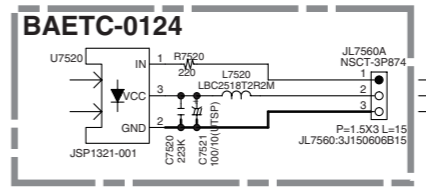
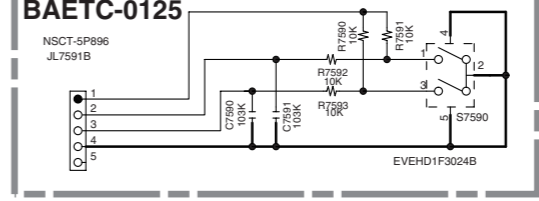

**U0043** **FRONT DIGITAL INPUT PC BOARD** **BAETC-0124-1A**

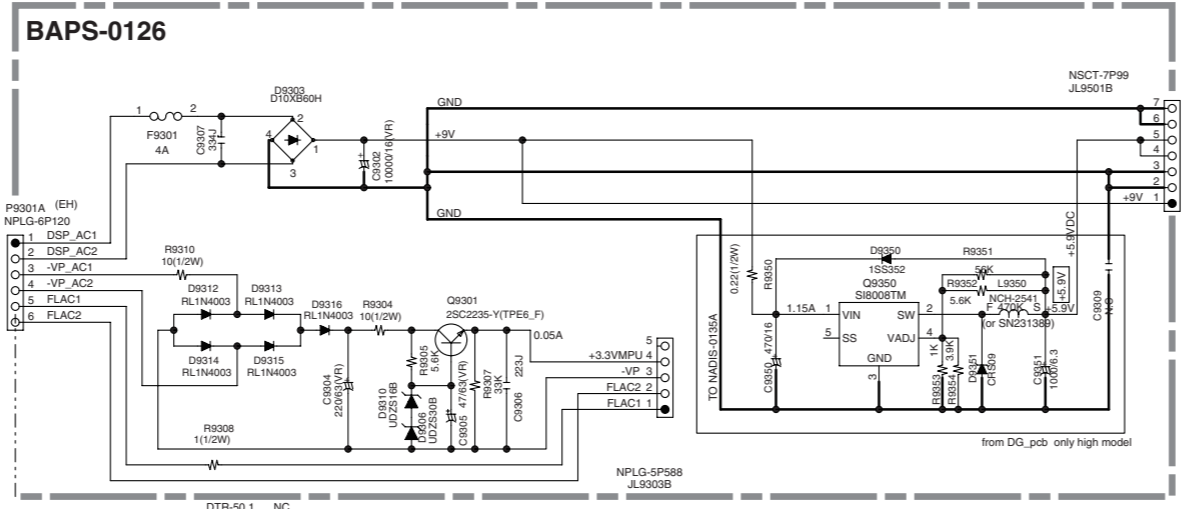

**U0045**  
**FUSE PC BOARD**  
**BAPS-0126-1A**

1

2

3

4

5

A B C D E F G H

SCHEMATIC DIAGRAM-20

U0061

FRONT HDMI TERMINAL PC BOARD

1 BAHDM-0291-1B

(PART-31)

FRONT HDMI SECTION

BAHDM-0291

HDMI IN(FRONT)

HDMI IN(FRONT)

HDMI IN(FRONT)

HDMI IN(FRONT)

HDMI IN(FRONT)

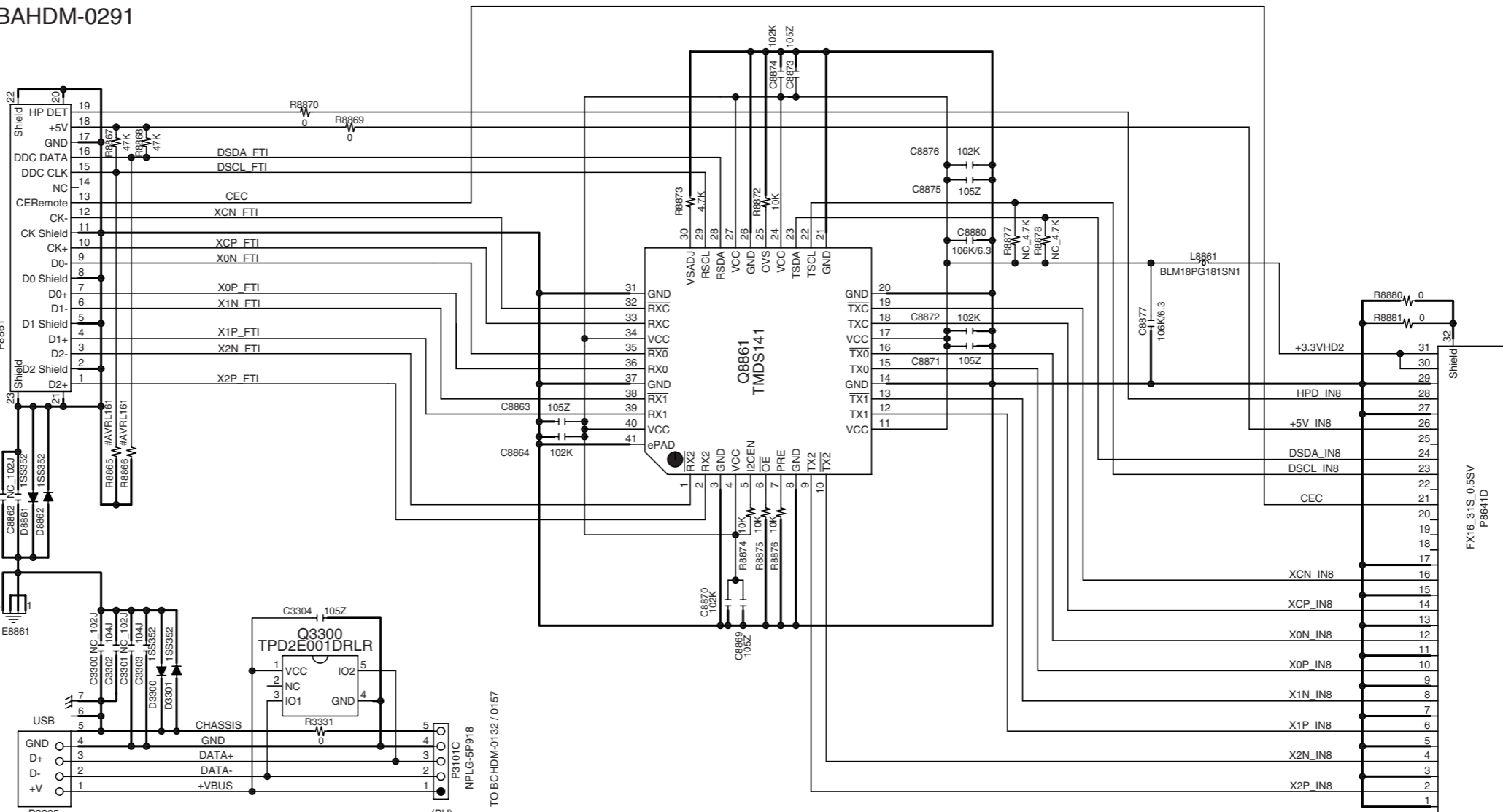

TO BCHDM-0132

# PRINTED CIRCUIT BOARD VIEW-1

**U0010**  
**AMPLIFIRE CIRCUIT**  
**PC BOARD**  
**BAAMP-0072-1K**

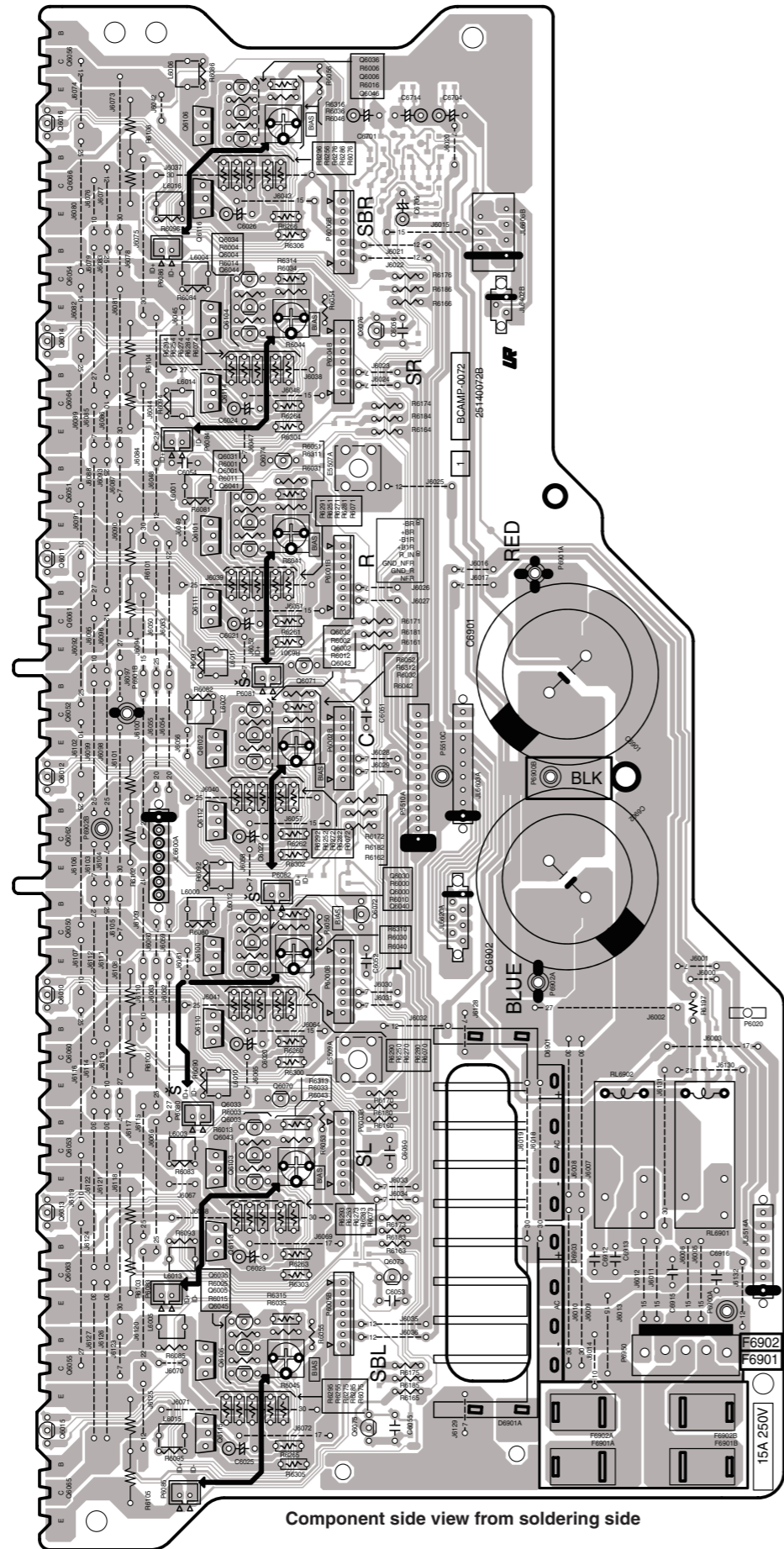

Component side view from soldering side

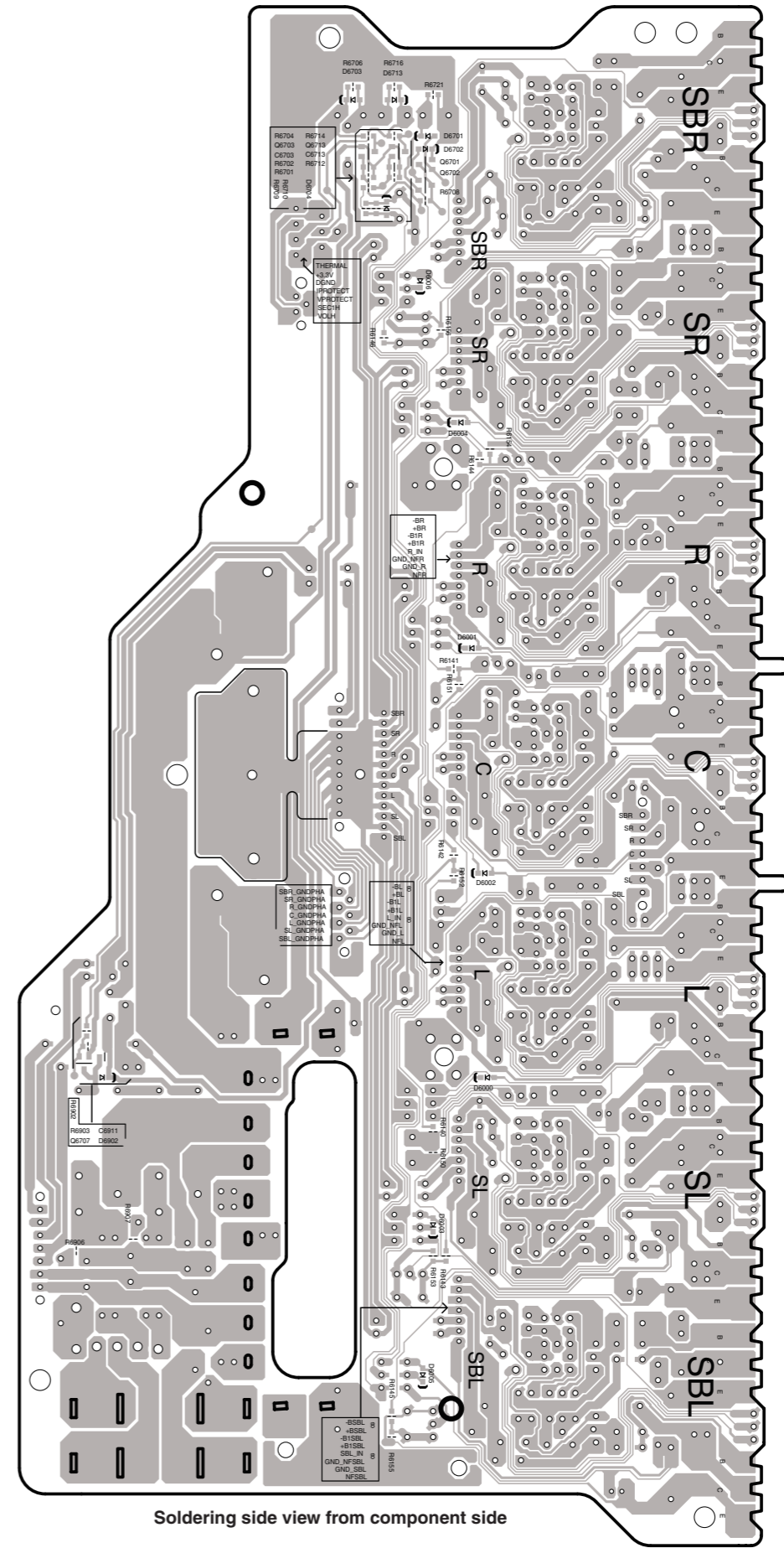

Soldering side view from component side

# PRINTED CIRCUIT BOARD VIEW-2

**U0011** AUDIO INPUT CIRCUIT PC BOARD  
BAASP-0073-1K

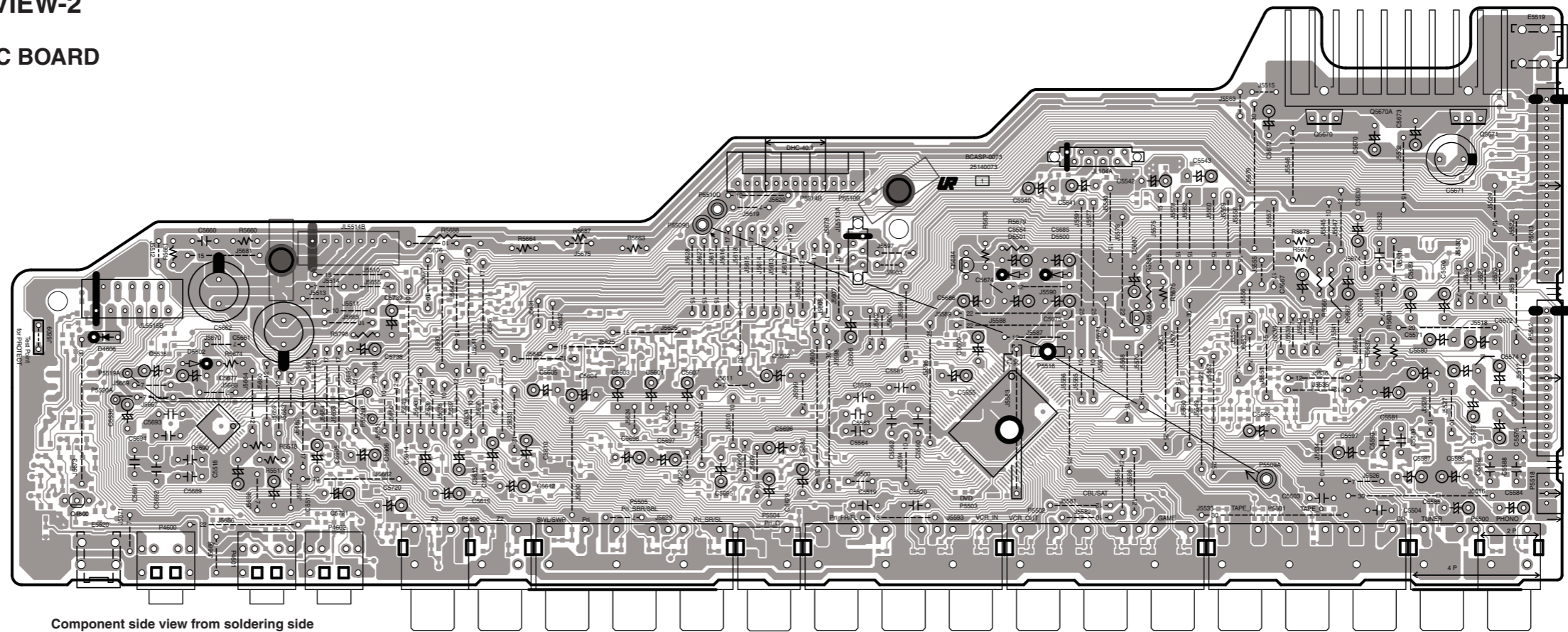

Component side view from soldering side

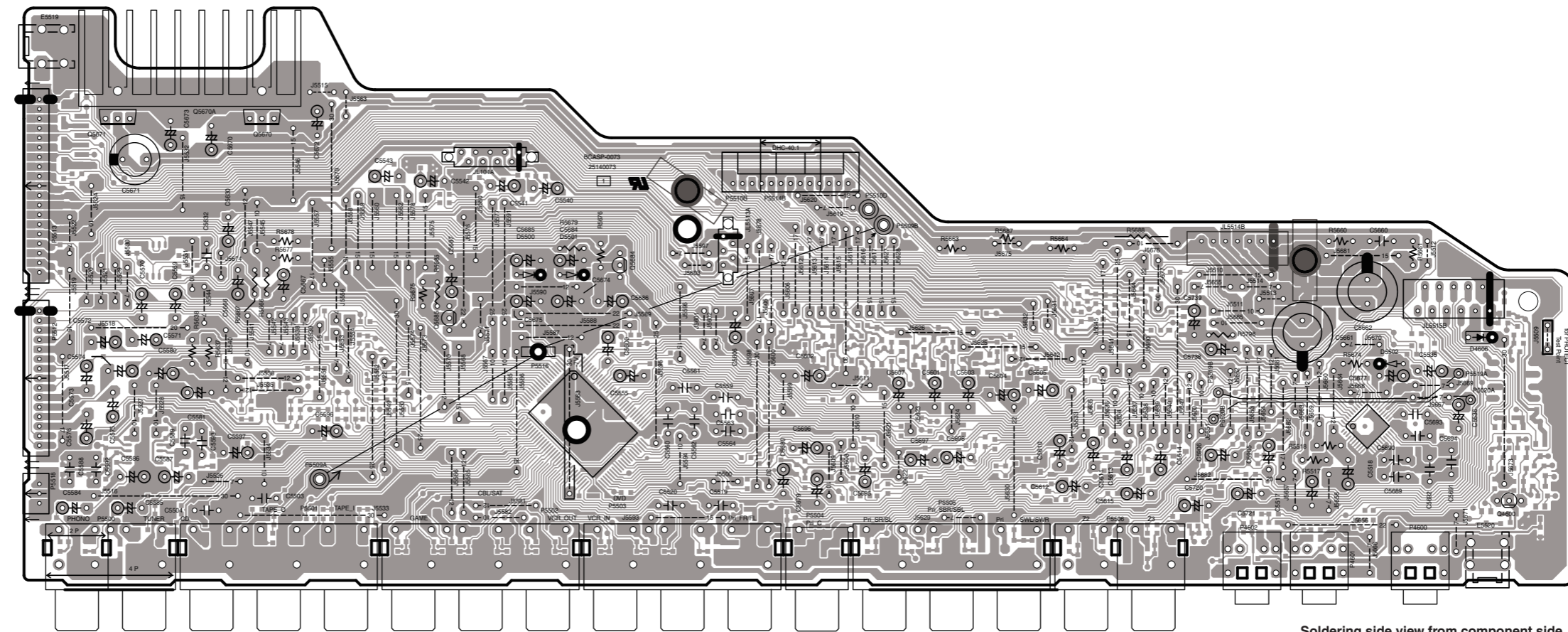

Soldering side view from component side



# PRINTED CIRCUIT BOARD VIEW-3

**U0020** SPEAKER TERMINAL-1 PC BOARD  
BATRM-0083-1G/-1H

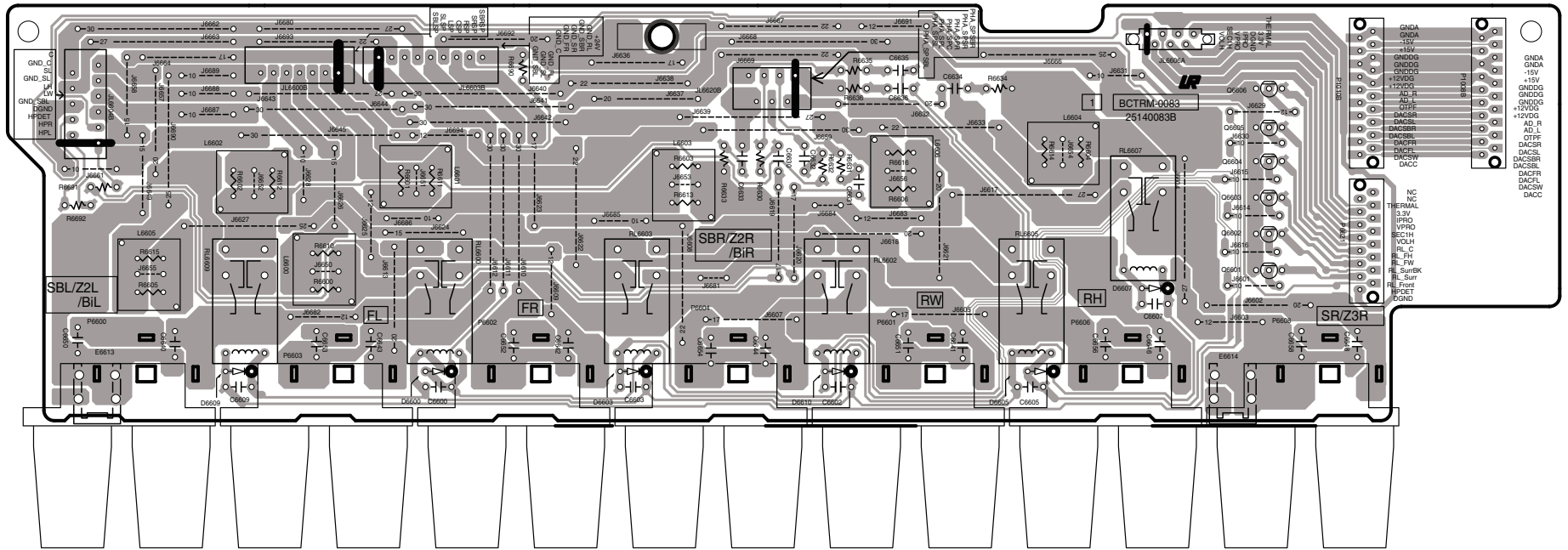

Soldering side view

### PRINTED CIRCUIT BOARD VIEW-4

#### U0024 POWER AMP. INPUT CIRCUIT PC BOARD BACLA-0087-1G/-1H

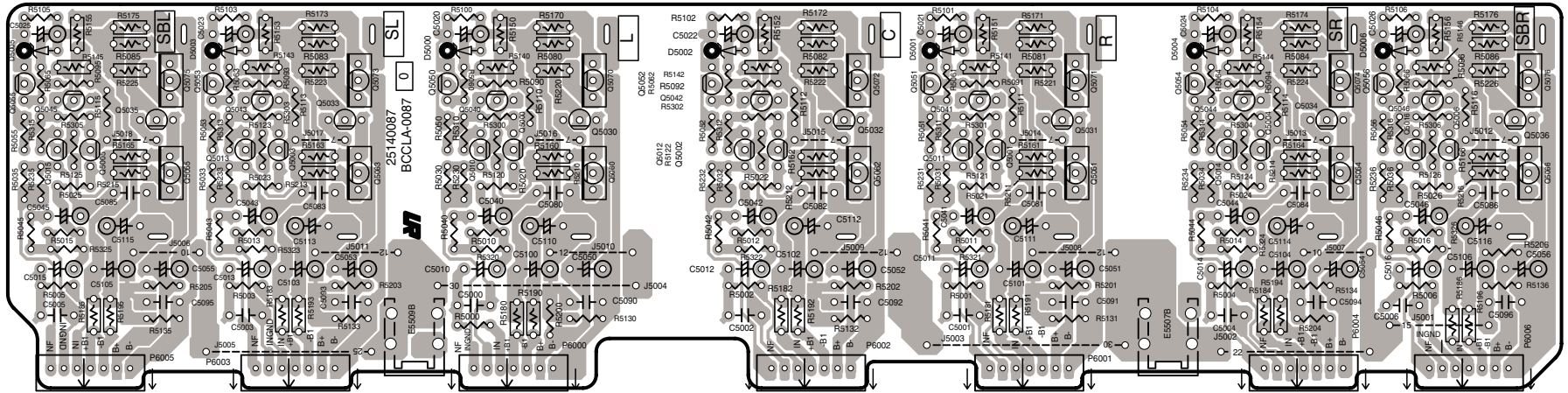

Soldering side view

#### U0012 THERMISTOR PC BOARD BAETC-0074-1K

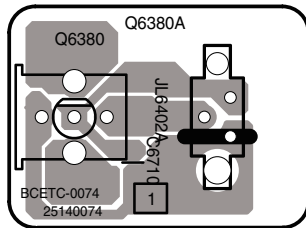

Soldering side view

#### U0015 AC INLET TERMINAL PC BOARD BAETC-0089-1K

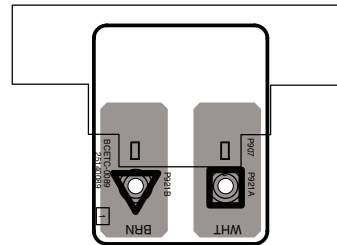

Soldering side view

# PRINTED CIRCUIT BOARD VIEW-5

## U0021 PRIMARY POWER SUPPLY PC BOARD BAPS-0084-1G/-1H

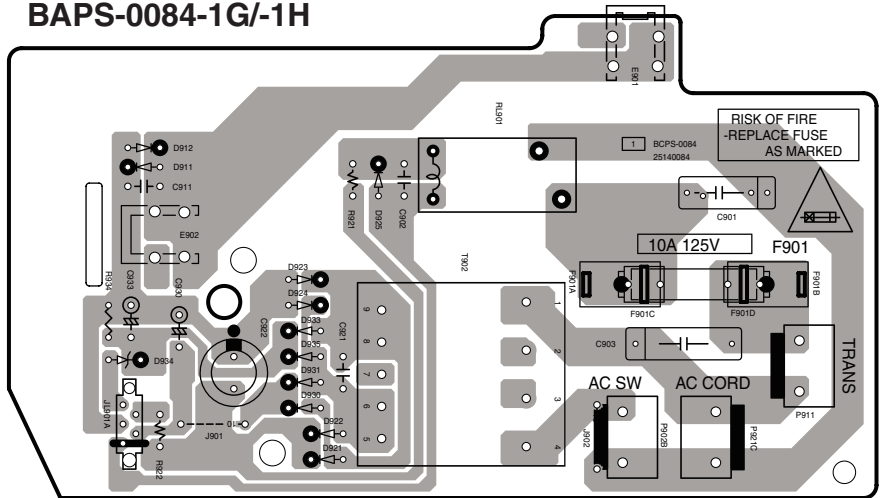

Soldering side view

## U0022 SPEAKER TERMINAL-2 PC BOARD BATRM-0085-1G/-1H

Soldering side view

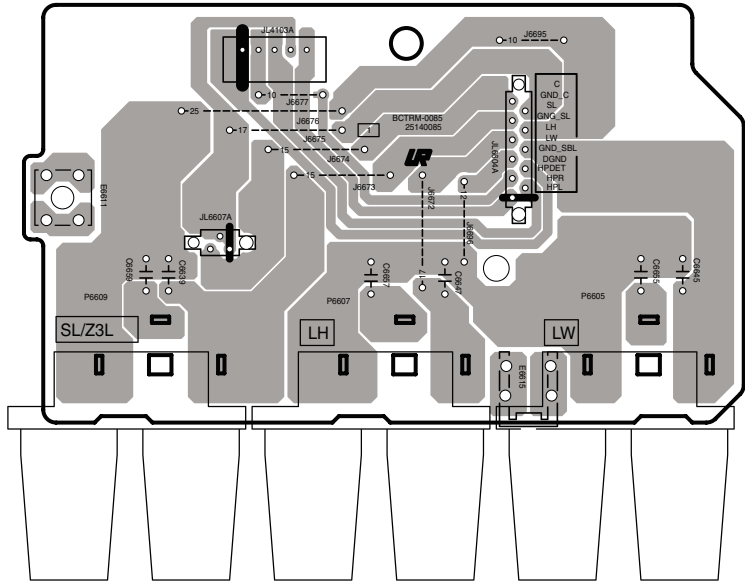

## U008 CENTER SPEAKER TERMINAL PC BOARD BATRM-0086

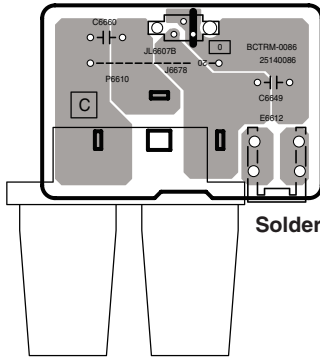

Soldering side view



PRINTED CIRCUIT BOARD VIEW-7

U0031 CPU CIRCUIT PC BOARD BACPU-0100-1K/1L

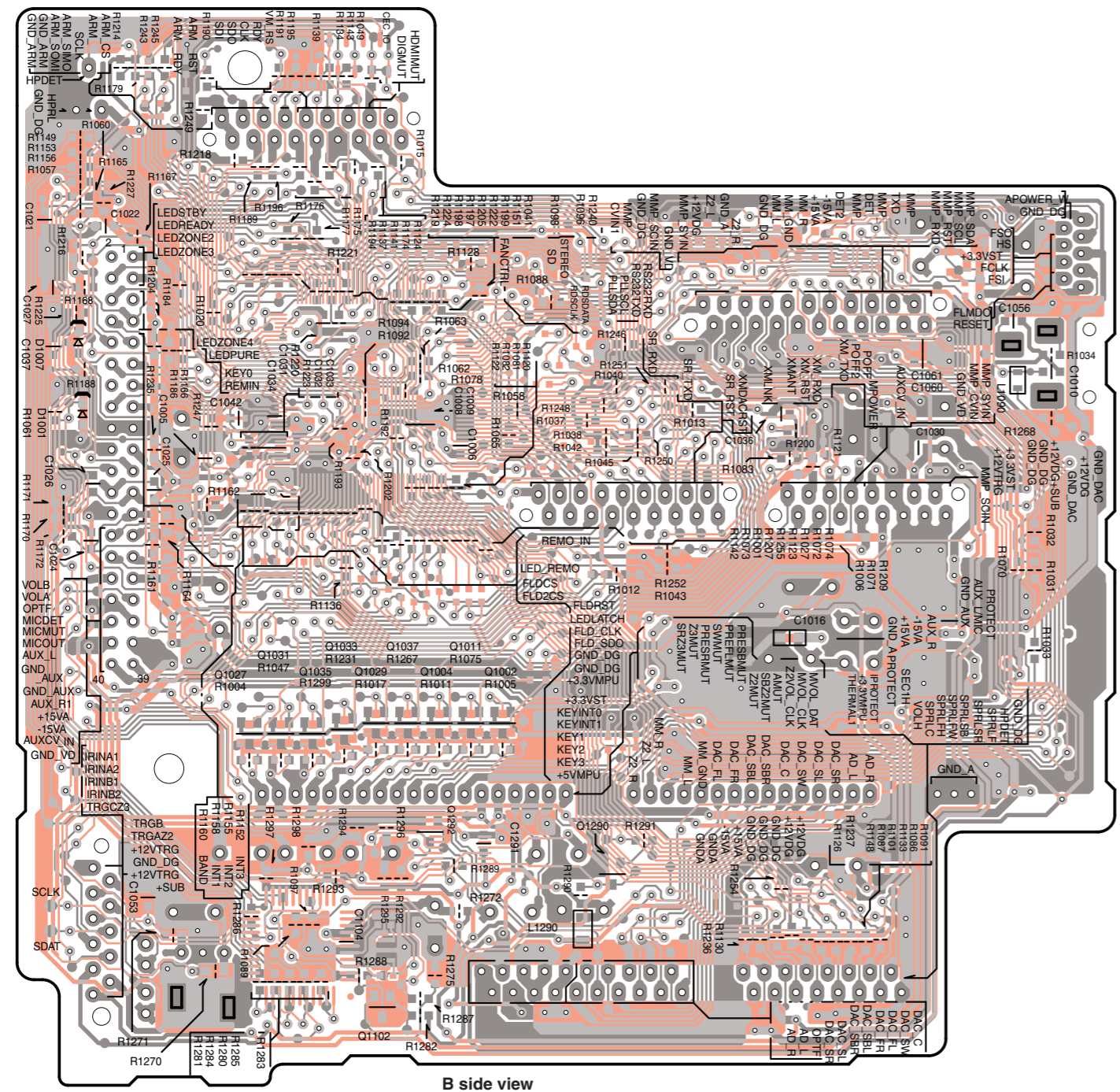

B side view

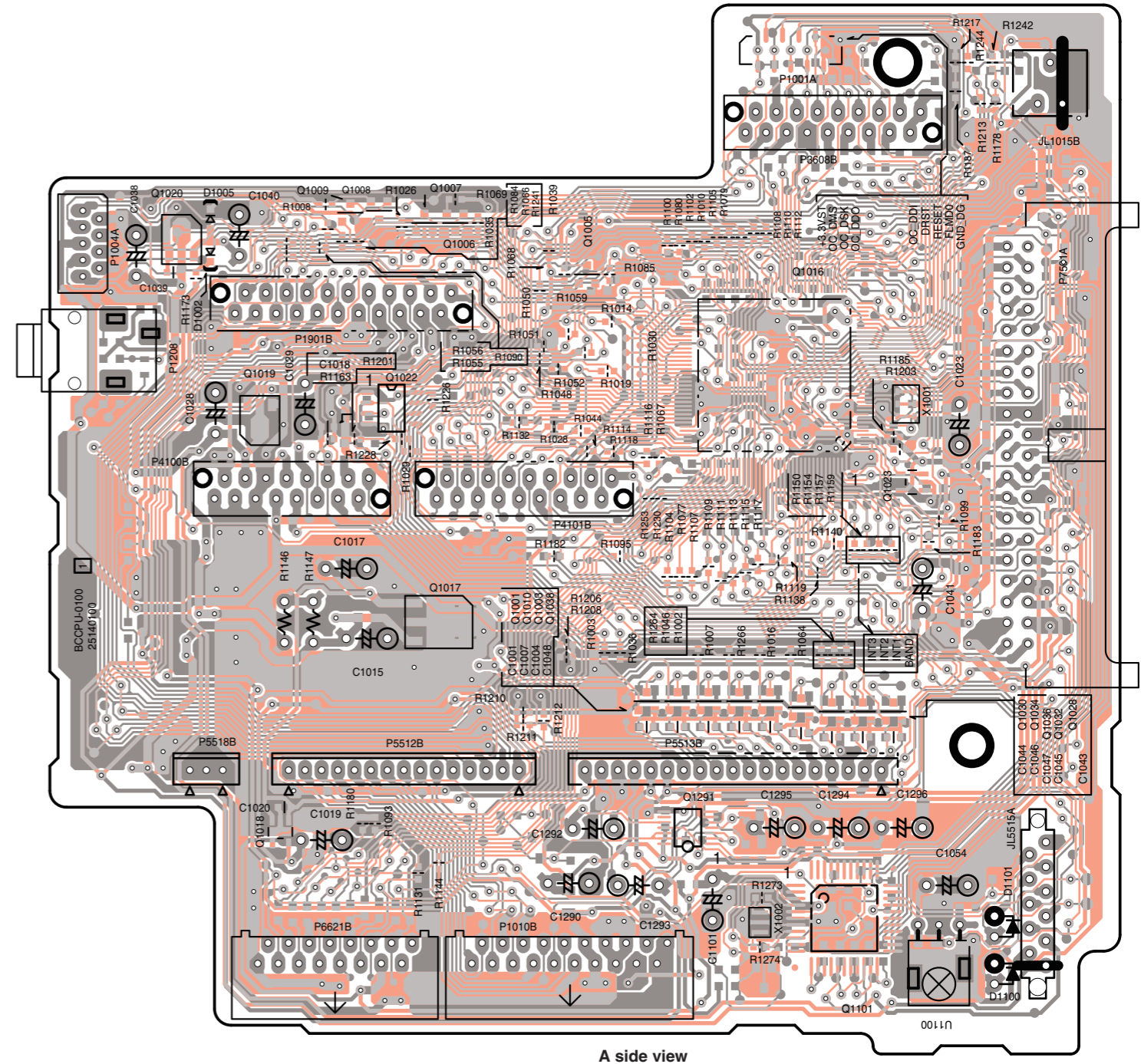

A side view

PRINTED CIRCUIT BOARD VIEW-8

U0032 VIDEO CIRCUIT PC BOARD  
BAVD-0101-1K/1L

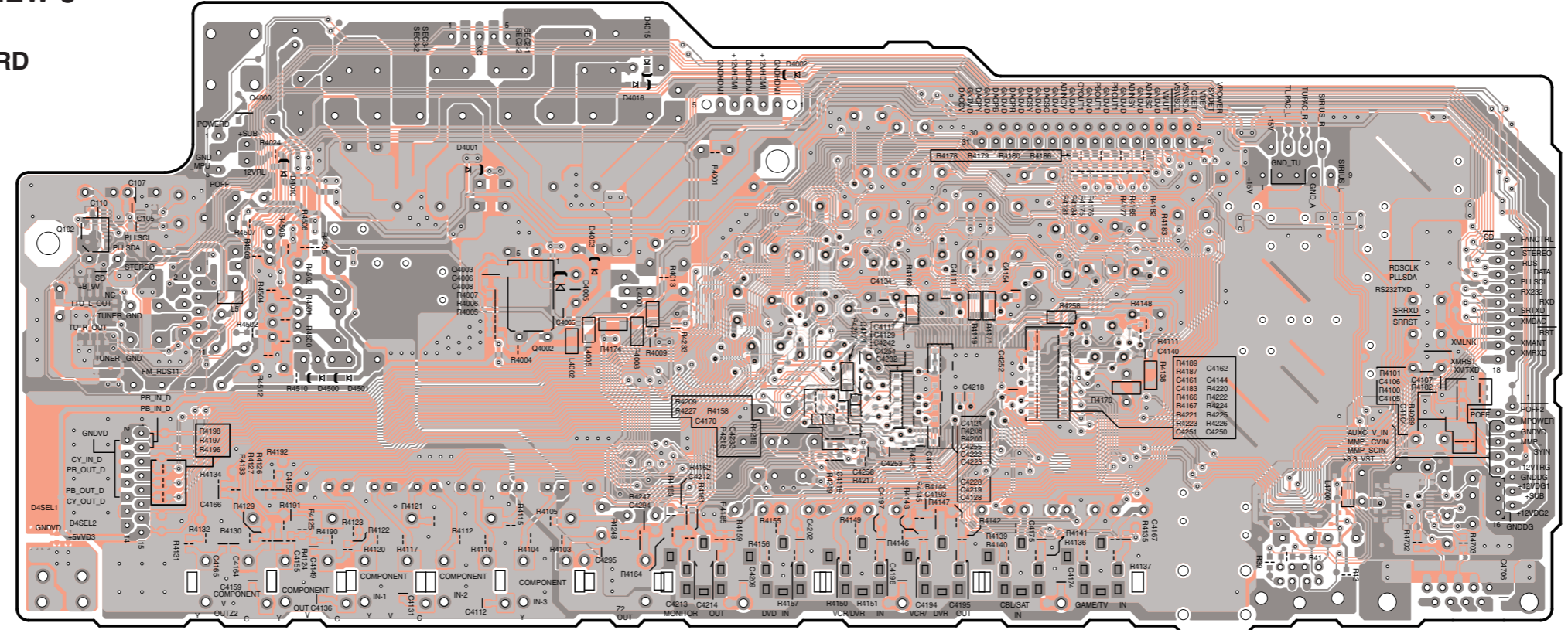

B side view

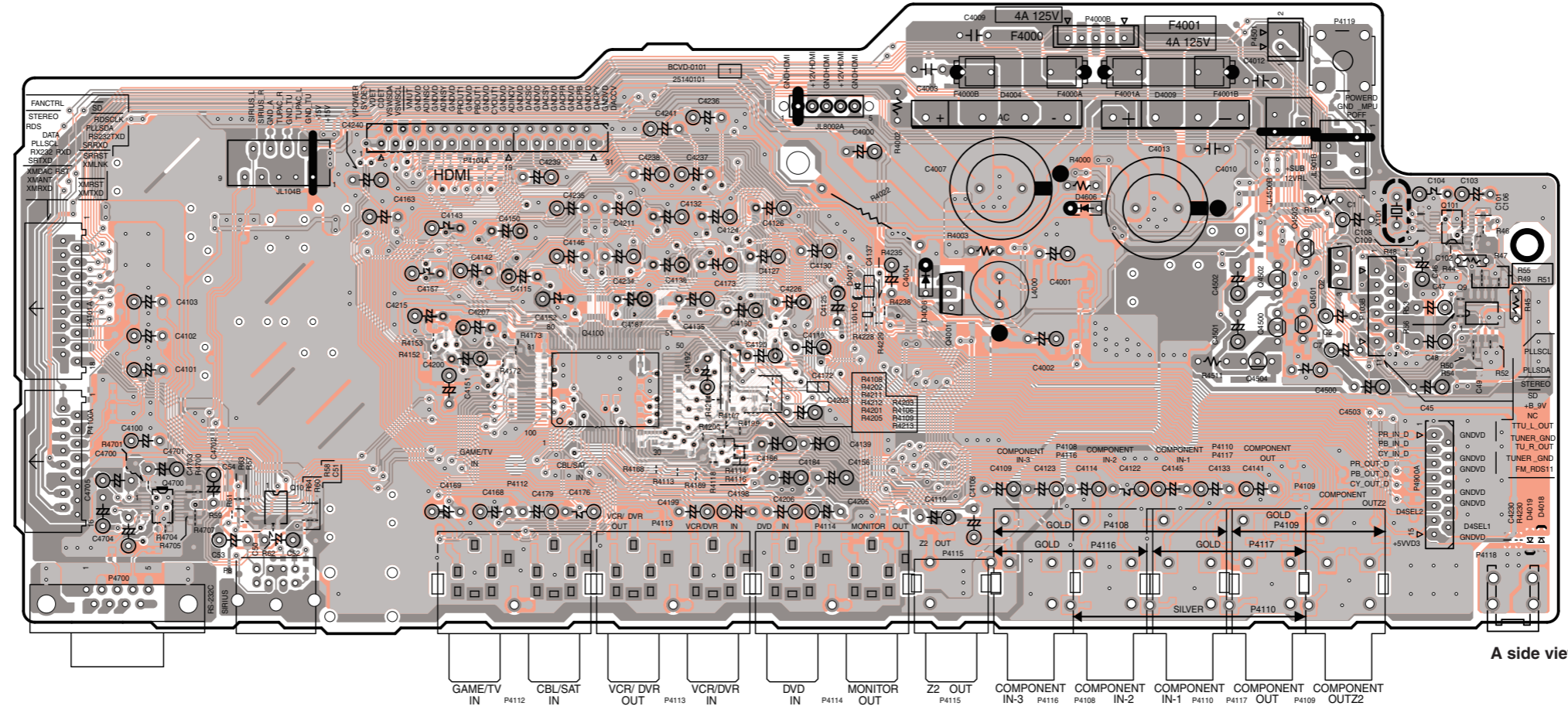

A side view

GAME/TV IN P4112  
 CBL/SAT IN  
 VCR/DVR OUT P4113  
 VCR/DVR IN  
 DVD IN P4114  
 MONITOR OUT  
 Z2 OUT P4115  
 COMPONENT IN-3 P4116  
 COMPONENT IN-2 P4108  
 COMPONENT IN-1 P4110  
 COMPONENT OUT P4117  
 COMPONENT OUT2 P4109

# PRINTED CIRCUIT BOARD VIEW-9

## U0033 UNIVERSAL PORT PC BOARD BAETC-0103-1K/-1L

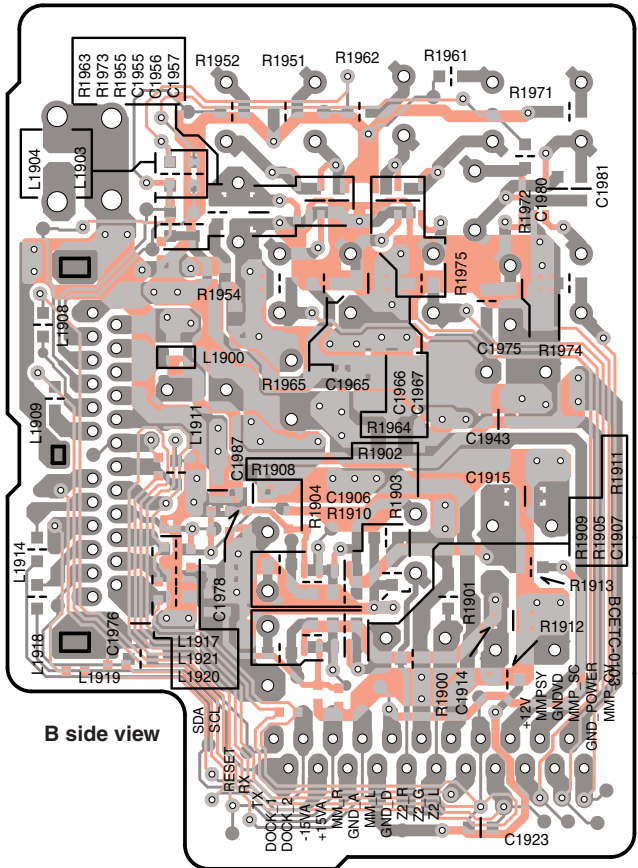

B side view

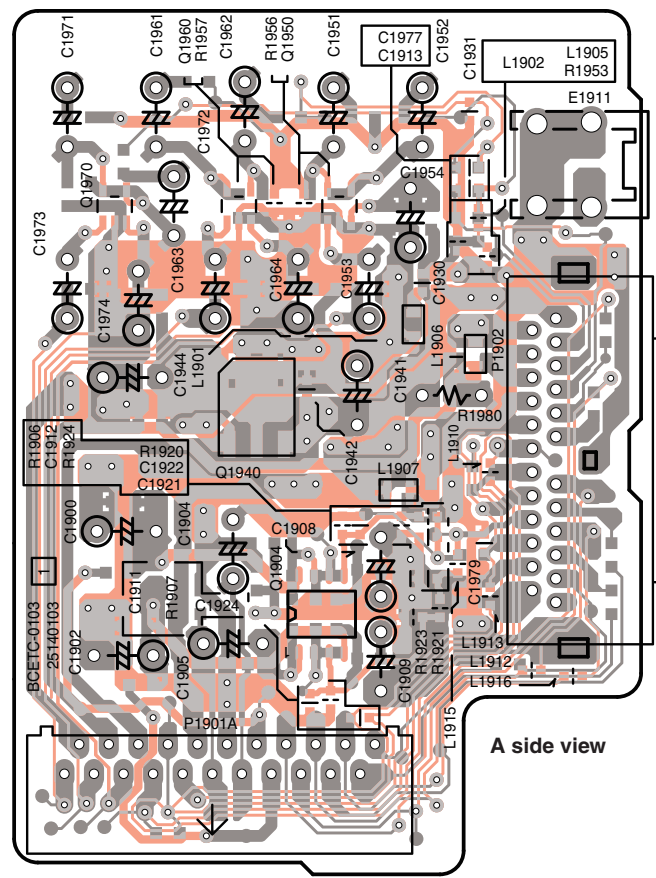

A side view

PRINTED CIRCUIT BOARD VIEWS-10

**U0040 DISPLAY CIRCUIT PC BOARD (BADIS-0121-1A)**

Component side view from soldering side

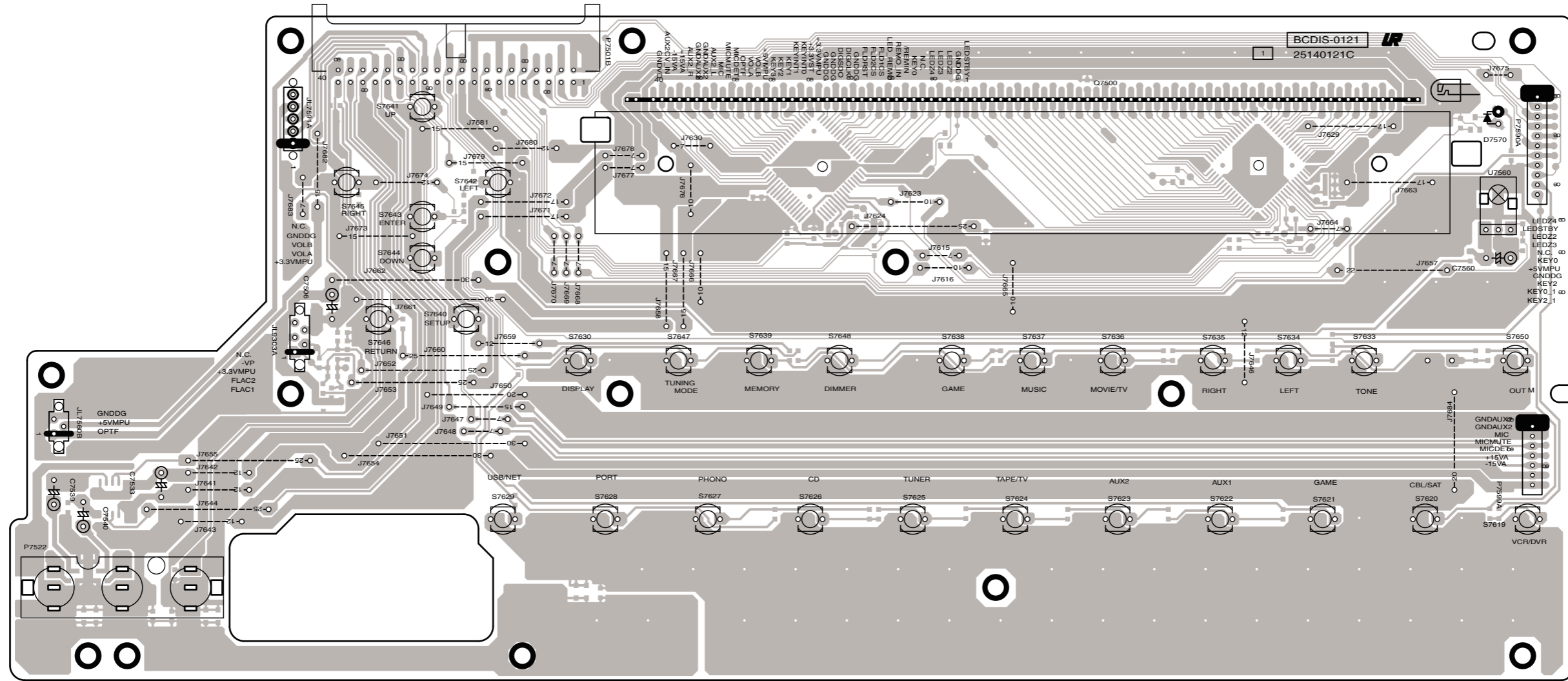

**U0042 HEADPHONE PC BOARD (BAETC-0123-1A)**

Component side view from soldering side

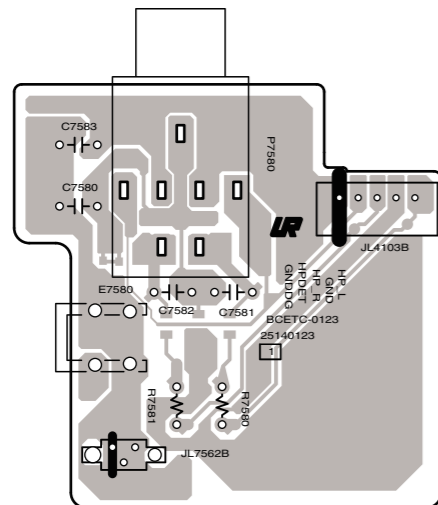

**U0043 FRONT DIGITAL INPUT PC BOARD (BAETC-0124-1A)**

Component side view from soldering side

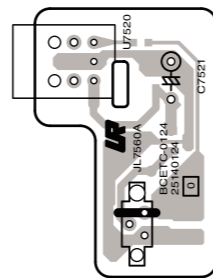

**U0046 SUPPORT PC BOARD-1 (BAETC-0127-1A)**

Component side view from soldering side

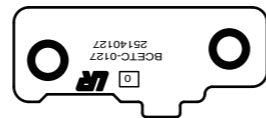

**U0044 VOLUME PC BOARD (BAETC-0125-1A)**

Component side view from soldering side

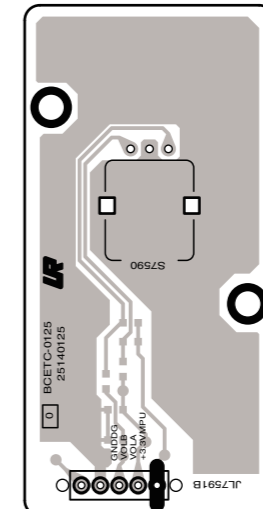



PRINTED CIRCUIT BOARD VIEWS-11

**U0040 DISPLAY CIRCUIT PC BOARD (BADIS-0121-1A)**

Soldering side view from component side

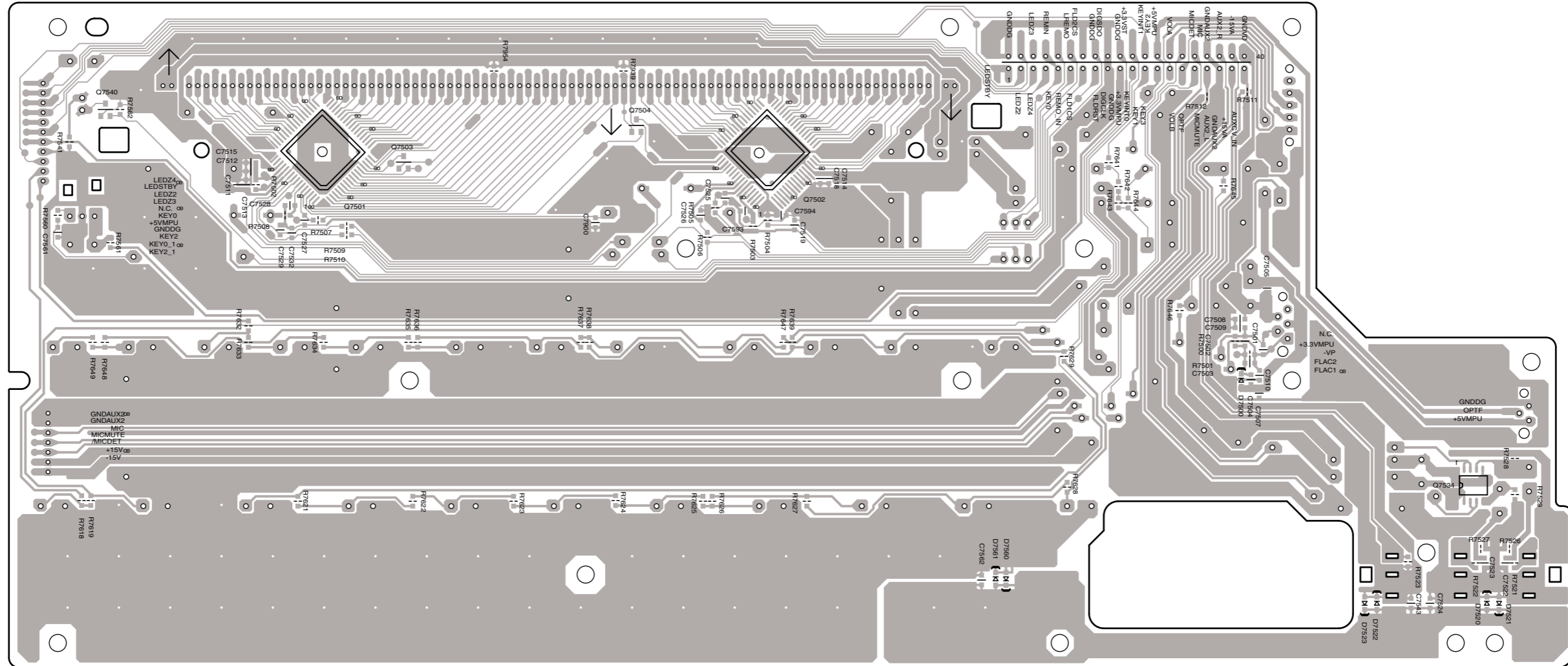

**U0042 HEADPHONE PC BOARD (BAETC-0123-1A)**

Soldering side view from component side

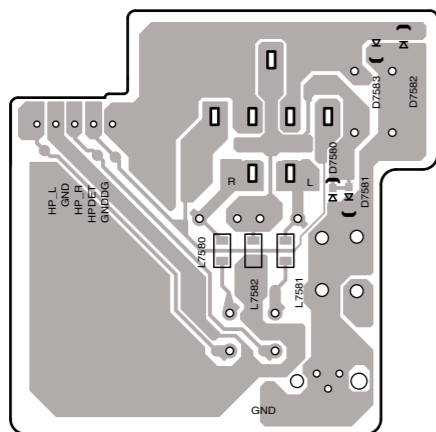

**U0043 FRONT DIGITAL INPUT PC BOARD (BAETC-0124-1A)**

Soldering side view from component side

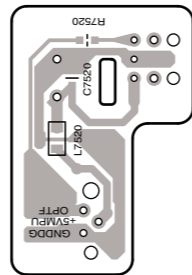

**U0046 SUPPORT PC BOARD-1 (BAETC-0127-1A)**

Soldering side view from component side



**U0044 VOLUME PC BOARD (BAETC-0125-1A)**

Soldering side view from component side

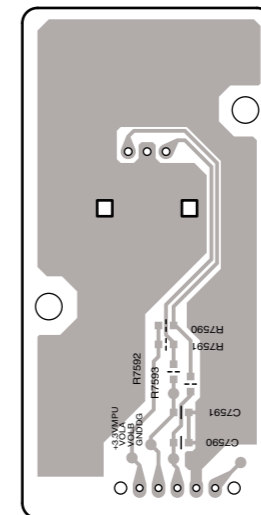



PRINTED CIRCUIT BOARD VIEW-13

U005 HDMI CIRCUIT PC BOARD BAHDM-0132-1E

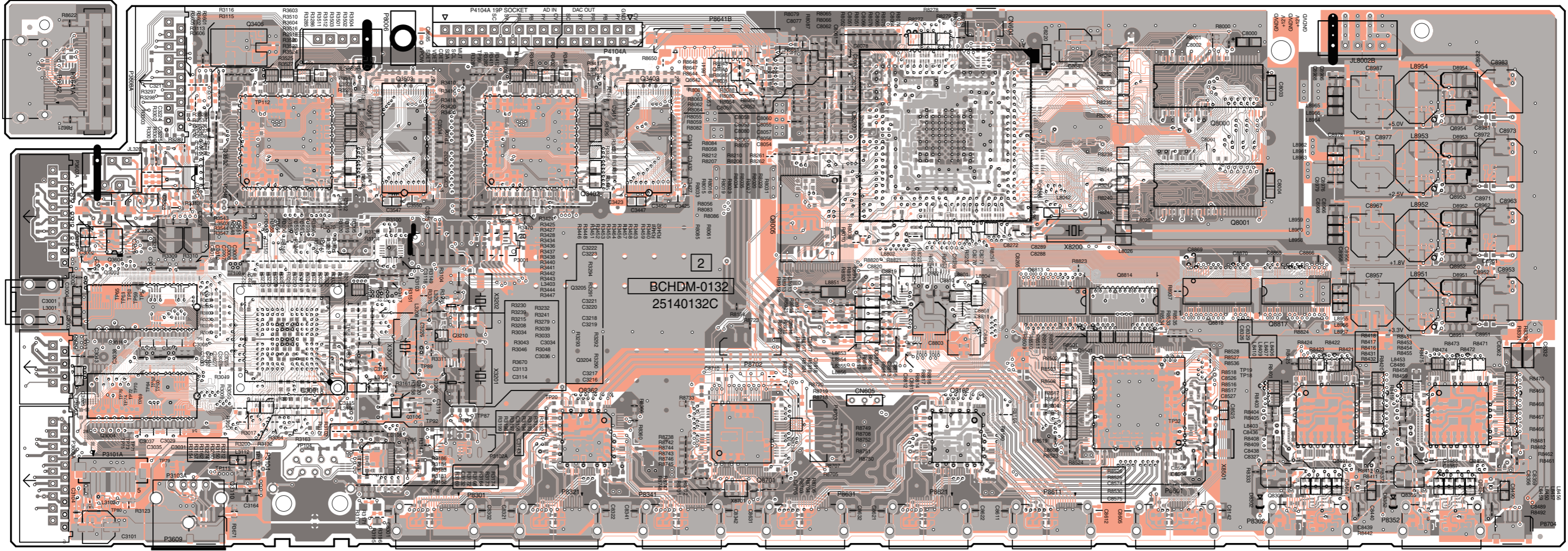

P8703A

A-side view

A side pattern color  
B side pattern color

PRINTED CIRCUIT BOARD VIEW-14

U005 HDMI CIRCUIT PC BOARD BAHDM-0132-1E

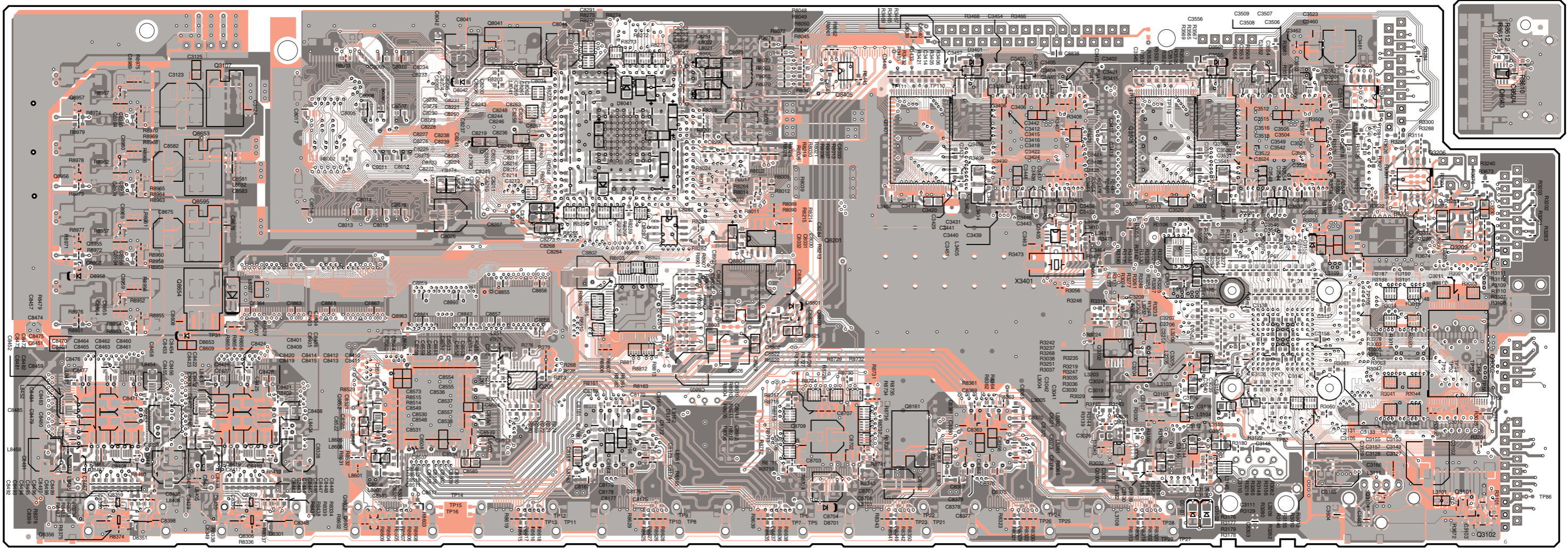

B-side view

- A side pattern color
- B side pattern color

PRINTED CIRCUIT BOARD VIEWS-15

**U0061** FRONT HDMI TERMINAL PC BOARD  
BAHDM-0291-1B

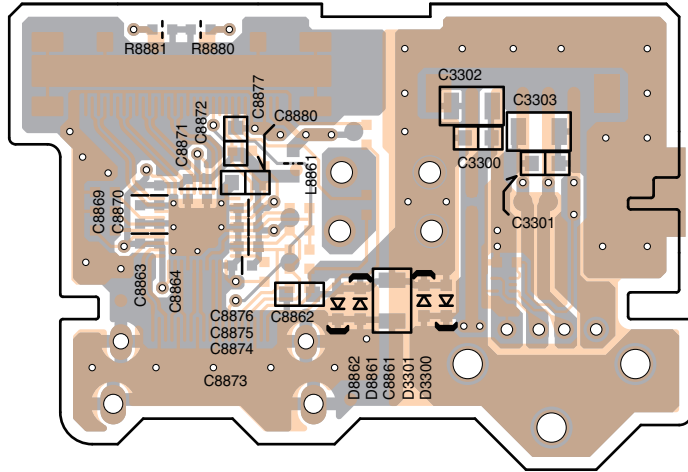

B side view

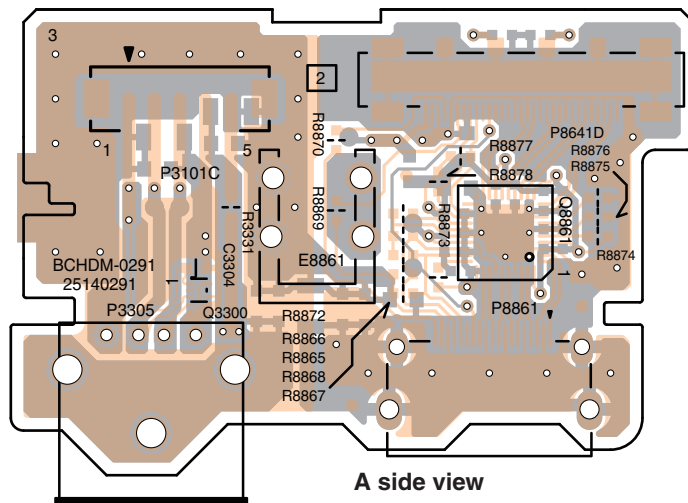

A side view

■ B side pattern  
■ A side pattern

# PACKING PROCEDURE

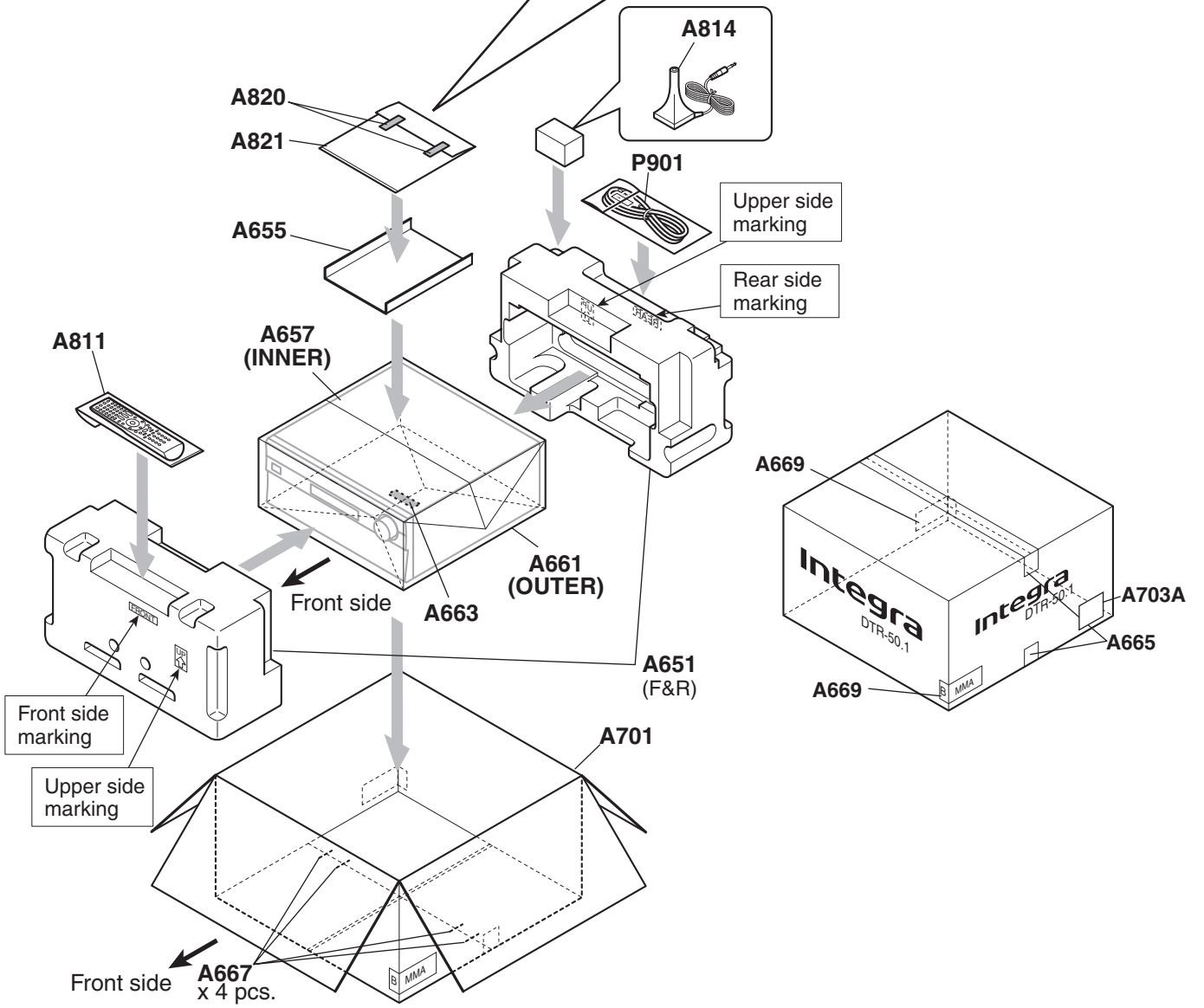
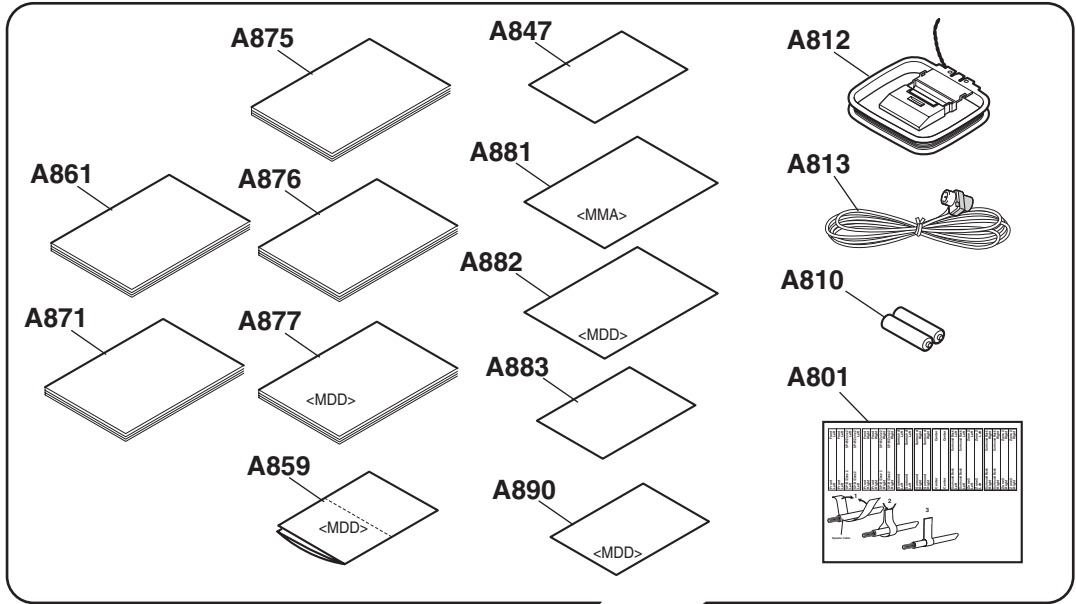

## DTR-50.1

## &lt;Note&gt;

Parts marked by "NSP" are generally unavailable because they are not in our Master Spare Parts List.

NOTE : THE COMPONENTS IDENTIFIED BY THE MARK  
! ARE CRITICAL FOR RISK OF FIRE AND  
ELECTRIC SHOCK. REPLACE ONLY WITH PART  
NUMBER SPECIFIED.

<MDD> : USA model

<MMA> : Austrarian model

## EXPLODED VIEW PARTS LIST

EXPLODED	REF. NO.	PART NAME	DESCRIPTION	Q'TY	PART NO. (SN)	REMARKS
EXPLODED	<b>[SEMI CONDUCTOR]</b>					
EXPLODED	Q6050	TR	TTC0001(Q_T)TO3PN	1	2204130	N
EXPLODED	Q6050A	ISO SHEET	AC238	2	223024	
EXPLODED	Q6050B	ISO SHEET	ISO SHEET	6	223041	
EXPLODED	Q6051	TR	TTC0001(Q_T)TO3PN	1	2204130	N
EXPLODED	Q6052	TR	TTC0001(Q_T)TO3PN	1	2204130	N
EXPLODED	Q6053	TR	TTC0001(Q_T)TO3PN	1	2204130	N
EXPLODED	Q6054	TR	TTC0001(Q_T)TO3PN	1	2204130	N
EXPLODED	Q6055	TR	TTC0001(Q_T)TO3PN	1	2204130	N
EXPLODED	Q6056	TR	TTC0001(Q_T)TO3PN	1	2204130	N
EXPLODED	Q6060	TR	TTA0001(Q_T)TO3PN	1	2204120	N
EXPLODED	Q6061	TR	TTA0001(Q_T)TO3PN	1	2204120	N
EXPLODED	Q6062	TR	TTA0001(Q_T)TO3PN	1	2204120	N
EXPLODED	Q6063	TR	TTA0001(Q_T)TO3PN	1	2204120	N
EXPLODED	Q6064	TR	TTA0001(Q_T)TO3PN	1	2204120	N
EXPLODED	Q6065	TR	TTA0001(Q_T)TO3PN	1	2204120	N
EXPLODED	Q6066	TR	TTA0001(Q_T)TO3PN	1	2204120	N
EXPLODED	<b>[TRANS COIL]</b>					
EXPLODED	T901	P TRANS	NPT-1571D	1	2301935A	!, <MDD>
EXPLODED	T901	P TRANS	NPT-1571M	1	2301936B	!, <MMA>
EXPLODED	<b>[SW TRM]</b>					
EXPLODED	F4000	FUSE	4A-UL/T-233	1	252325GR	!
EXPLODED	F4000or	FUSE	4A-T/UL-ST2	(1)	252257GR	!
EXPLODED	F4001	FUSE	4A-UL/T-233	1	252325GR	!
EXPLODED	F4001or	FUSE	4A-T/UL-ST2	(1)	252257GR	!
EXPLODED	F6901	FUSE	15A-TUL-250V	1	252303GR	!
EXPLODED	F6902	FUSE	15A-TUL-250V	1	252303GR	!

EXPLODED	F901	FUSE	6.3A-SE-EAK FUSE	1	252079GR	!, <MMA>	
EXPLODED	F901or	FUSE	6.3A-SE-TL250V	(1)	252279GR	<MMA>	
EXPLODED	F901	FUSE	12A-TUL-250V	1	252301GR	!, <MDD>	
EXPLODED	F901A	FUSE LABEL	12A/250V	1	29362325	<MDD>	
EXPLODED	F901A	LABEL	T6.3AL/250V	1	29361681	<MMA>	
EXPLODED	JL4103	JUMPER LEAD	JL5 400 H	1	---	NSP	806/7.9
EXPLODED	P103	FFC	NCFC7-111012	1	2047111012		
EXPLODED	P3101	SOCKET AS	NSAS-10P1813	1	2009991173UL		FRONT USB
EXPLODED	P4104	FFC	NCFC7-311012	1	2047311012		
EXPLODED	P500	WIRE TIE	BSK-1	15	260208		
EXPLODED	P6600A	P RIVET	JB-407A-C	22	880052	<MMA>	
EXPLODED	P691	FAN	D05X-12TL	1	24502317		
EXPLODED	P693	FAN	D09A-12PG13	1	24502328		
EXPLODED	P7501	SOCKET AS	NSAS-80P1805	1	2009991168UL		
EXPLODED	P8641	FFC	NCFC7-31007	1	204D31007		FRONT HDMI
EXPLODED	P902B	SOCKET AS	NSAS-3P1760	1	2009991127UL		
EXPLODED	<b>[CHASSIS SCREW]</b>						
EXPLODED	A001	CHASSIS	807	1	27100539	N	
EXPLODED	A003	LEG	---	4	27175419		
EXPLODED	A005	CUSHION	(LEG)	4	28141660		t1.5
EXPLODED	A007	CUSHION	(BUTYL)	1	28141748		inside LEG:0.3:MT::
EXPLODED	A009	SCREW	3TTB+8B(3CM)SR	4	801637		BOTTOM LEG
EXPLODED	A015	SCREW	4TTC+8C(3BC)	4	830440089GR		TRANS
EXPLODED	A017	SPACER	---	1	27270439		
EXPLODED	A018	RETAINER	(TR)	1	27142165	N	
EXPLODED	A021	BRACKET	(FAN-L)	1	27131046		
EXPLODED	A023	BUSHING	(FAN-L)	4	28170091A		BRACKET(FAN-L)
EXPLODED	A025	SCREW	3TTB+8B(3BC)	3	838430088GR		BRACKET(FAN-L)
EXPLODED	A029	HEAT SINK	---	1	27160620A		
EXPLODED	A031	SCREW	3SMS8W.SW+14B(CU)	14	801634		POWER-TR
EXPLODED	A033	SCREW	3TTB+8B(3CM)SR	1	801637		THERMISTER
EXPLODED	A041	RETAINER	(HT-L8)	1	27142110A		
EXPLODED	A043	RETAINER	(HT-R8)	1	27142111		
EXPLODED	A044	SCREW	3TTB+8B(3CM)SR	2	801637		AMP0072-CLA0087
EXPLODED	A045	SCREW	3TTB+8B(3CM)SR	4	801637		AF_PCB-DIODE_PCB
EXPLODED	A049	SCREW	3TTB+8B(3CM)SR	6	801637		FFC-HOLD_PWB
EXPLODED	A051	BRACKET	(FAN-S)	1	27131047		
EXPLODED	A052	CUSHION	T10 x 10 x 10EPT	1	28141813		BKT(FAN-S)
EXPLODED	A053	BUSHING	(FAN-S)	2	28170090		BKT(FAN-S)
EXPLODED	A055	SCREW	3TTB+8B(3CM)SR	2	801637		BRACKET(FAN-S)
EXPLODED	A057	IB CUSHION	W15 x 3t TAPE	1	28141585		BLOCK_CAP:0.03:MT::



EXPLODED	A059	SCREW	3TTB+8B(3CM)SR	2	801637		ETC0075<->HS
EXPLODED	A061	RETAINER	(PC)	1	27142125		AMP_PCB
EXPLODED	A063	RIVET	P-RIVET NRP-345	2	880009		RETAINER(PC)
EXPLODED	A065	CUSHION	---	4	28141783		AMP_PCB
EXPLODED	A067	CUSHION	(PCB)	2	28141789		RETAINER(PC)
EXPLODED	A071	CLAMP	WS-2NS	1	27300833		HP_CBL
EXPLODED	A075	HOLDER	HOLDER KGLS-8S	6	27190480		CHASSIS
EXPLODED	A077	HOLDER	KGPS-14RF	8	27190802		CHASSIS
EXPLODED	A079	HOLDER	KGLS-14S	1	27190164		VIDEO<->HDMI
EXPLODED	A081	HOLDER	HOLDER KGLS-18S	4	27190470		ASP,VIDEO
EXPLODED	A085	HOLDER	KGLS-12RT	1	27190266		PS<->CHASSIS
EXPLODED	A087	HOLDER	KGLS-10RT	1	27190428A		DAC<->CHASSIS
EXPLODED	A089	HOLDER	KGLS-22RT	1	27190772		DAC<->CPUPCB
EXPLODED	A091	HOLDER	SPM-4	4	27191154		CHASSIS
EXPLODED	A101	SCREW	3TTB+8B(3CM)SR	1	801637		PS<->TRM
EXPLODED	A105	SCREW	4TTC+8C(3BC)	2	830440089GR		RETAINER(HT-L8)
EXPLODED	A107	SCREW	3TTB+8B(3CM)SR	2	801637		ASP,DACPBC
EXPLODED	A109	SCREW	3TTB+8B(3BC)	2	838430088GR		CHABTM-RET(HT-R8)
EXPLODED	A111	CUSHION	(BUTYL)	1	28141748		RETAINER(HT-L):0.02:MT::
EXPLODED	A113	CUSHION	(BUTYL)	1	28141748		PCB_PARTS:0.05:::
EXPLODED	A115	TAPE	TAPE(CLOTH-8U)	1	29110082		REAR-P:0.02:MT::
EXPLODED	A121	LABEL	(PT)	1	29363409-1		50.1TRANS
EXPLODED	A131	BRACKET	(F)807	1	27131065A		△A
EXPLODED	A133	BUSHING	L125	2	28170004		BRACKET(F)
EXPLODED	A135	HOLDER	(CLAMP) UA-0	1	27190432		BRACKET(F)
EXPLODED	A137	RETAINER	(SIDE)	2	27142107		
EXPLODED	A139	SCREW	3TTB+8B(3CM)SR	4	801637		RETAINER(SIDE)
EXPLODED	A141	TAPE	TAPE(CLOTH-16U)	1	29110083		HSINK(SP)_PWB:0.04:MT::
EXPLODED	A147	SCREW	3TTB+8B(3CM)SR	7	801637		BKT(F)-CHASSIS
EXPLODED	A171	REAR PANEL	DTR-50.1MDD	1	27124009A	N <MDD>	
EXPLODED	A171	REAR PANEL	DTR-50.1MMA	1	27124010B	N <MMA>	
EXPLODED	A173	SCREW	3TTB+8B(3BC)	48	838430088GR		REAR PANEL
EXPLODED	A175	SCREW	3P+6FN(3BC)	8	82143006GR		HDMI
EXPLODED	A177	SCREW	3P+6FN(3BC)	2	82143006GR		UNI-PORT
EXPLODED	A179	SCREW	3P+6FN(3BC)	1	82143006GR	<MDD>	SIRIUS
EXPLODED	A183	SCREW	4TTB+10B(3BC)	2	838440108GR		INLET
EXPLODED	A185	TRM	E TERMINAL	1	25060151		PHONO
EXPLODED	A189	WASHER	W3 x 10F(3BC)	1	87643010GR		PHONO
EXPLODED	A191	LABEL	(SP1)	1	29390790		
EXPLODED	A193	LABEL	(SP2)	1	29390791		
EXPLODED	[CABINET]						

EXPLODED	A207	F BRACKET	(B)	1	27111536C		△E CHANGE
EXPLODED	A215	KNOB	(STANDBY)	1	28325756		DTR(B)
EXPLODED	A225	KNOB	(CUR)B	1	28326682A		
EXPLODED	A229	P RIVET	P-3055B-8L	2	880048		KNOB(CUR)
EXPLODED	A321	RETAINER	(F)	1	27142155A		
EXPLODED	A323	SCREW	3TTB+8B(3CM)SR	1	801637		RETAINER(F)
EXPLODED	A325	SCREW	3TTB+10B(3BC)	1	838430108GR		RETAINER(F)
EXPLODED	A331	RETAINER	(HP)	1	27141787		DTR50.1
EXPLODED	A333	SNAP PLATE	SNAP PLATE	1	27301877		DTR_HPJACK
EXPLODED	A335	SCREW	3TTB+8B(3CM)SR	2	801637		HP-PCB
EXPLODED	A337	SCREW	3TTB+8B(3CM)SR	3	801637		HDMI/DIGITAL
EXPLODED	A339	SCREW	3TTB+8B(3CM)SR	2	801637		KNOB(VOL)
EXPLODED	A351	CUSHION	t5 x 30 x 5	2	28141562		F-PCB/FFC
EXPLODED	A353	CUSHION	(T3 x W35 x D10)	5	28141741		F_BRA-IDE_CBL
EXPLODED	A355	TAPE	TAPE(CLOTH-16U)	1	29110083		FFC:0.1:MT::
EXPLODED	A357	IB CUSHION	W15 x 3t TAPE	1	28141585		FLTUBE:0.04:MT::
EXPLODED	A363	SCREW	3TTB+8B(3CM)SR	18	801637		FBRACKET-BRACKET(F)
EXPLODED	A375	SCREW	3TTB+8B(3BC)	3	838430088GR		FPANEL-CHASSIS
EXPLODED	A377	SCREW	3TTB+8B(3BC)	3	838430088GR		F PANEL-F BRACKET
EXPLODED	A383	SCREW	3TTB+8B(3CM)SR	3	801637		FBKT-BKT(F)
EXPLODED	A385	SCREW	3TTB+8B(3CM)SR	1	801637		HP-BRACKET(F)
EXPLODED	A407	F PANEL	R50.1(B)	1	27213226	N <MMA>	
EXPLODED	A407	F PANEL	R50.1(B)	1	27213225A	N <MDD>	△B Change
EXPLODED	A409	BADGE	---	1	28135278		DTR
EXPLODED	A421	CLEAR PLT	---	1	28192233	N	
EXPLODED	A423	DECO FRM	---	1	28159049A		△C CHANGE
EXPLODED	A425	FACET	---	3	28198905		DTR
EXPLODED	A427	B PLATE	---	1	28133430		DTR(B)
EXPLODED	A431	GUIDE	(VOL)	1	27268227	N	DTR(B)
EXPLODED	A453	KNOB	(VOL)AS	1	28326231B	N	
EXPLODED	A461	CUSHION	t0.9 x d48	1	28141824		KNOB(VOL)
EXPLODED	A603	COVER	(B) (Bent)	1	28210037	N	807/50.1(B)
EXPLODED	A603	COVER	(B) (Not Bent)	1	28210037Z	N	807/50.1(B)
EXPLODED	A605	LABEL	HOOKUP-INTEGRA	1	29363195	<MDD>	COVER
EXPLODED	A607	LABEL	(COVER)	1	29364123		COVER(B)
EXPLODED	A611	SCREW	3TTB+8B(3BC)	3	838430088GR		COVER(B)
EXPLODED	A613	SCREW	4TTB+8C(3BC)	6	838440089GR		COVER(B)
EXPLODED	<b>[TUNER UNIT]</b>						
EXPLODED	<b>U001</b>	<b>U0010 + U0012 + U0013 + U0014</b>	<b>BAAMP-0072-1K *</b>	<b>1</b>	<b>1B234572-1K</b>	<b>N</b>	
EXPLODED	U0010	Power amplifier PC Board ass'y	BAAMP-0072-1K	1	1B2345072-1K	N	
EXPLODED	U0011	Audio input circit PC Board ass'y	BAASP-0073-1K	1	1B2345073-1K	N	

EXPLODED	U0012	Thermister PC Board ass'y	BAETC-0074-1K	1	---	N NSP
EXPLODED	U0013	Connection board	BAETC-0075-1K	1	---	N NSP
EXPLODED	U0014	AC Inlet terminal PC Board ass'y	BAETC-0089-1K	1	---	N NSP
EXPLODED	<b>U002</b>	<b>U0020 + U0021 + U0023 + U0024</b>	<b>BATRM-0083-1G *</b>	<b>1</b>	<b>1B234583-1G</b>	<b>N &lt;MDD&gt;</b>
EXPLODED	<b>U002</b>	<b>U0020 + U0021 + U0023 + U0024</b>	<b>BATRM-0083-1H *</b>	<b>1</b>	<b>1B234583-1H</b>	<b>N &lt;MMA&gt;</b>
EXPLODED	U0020	Speaker terminal-1 PC Board ass'y	BATRM-0083-1G	1	1B2345083-1G	N <MDD>
EXPLODED	U0020	Speaker terminal-1 PC Board ass'y	BATRM-0083-1H	1	1B2345083-1H	N <MMA>
EXPLODED	U0021	Primary power supply PC Board ass'y	BAPS-0084-1G	1	1B2345084-1G	N <MDD>
EXPLODED	U0021	Primary power supply PC Board ass'y	BAPS-0084-1H	1	1B2345084-1H	N <MMA>
EXPLODED	U0022	Speaker terminal-2 PC Board ass'y	BATRM-0085-1G	1	1B2345085-1G	N <MDD>
EXPLODED	U0022	Speaker terminal-2 PC Board ass'y	BATRM-0085-1H	1	1B2345085-1H	N <MMA>
EXPLODED	U0023	Center speaker terminal PC Board ass'y	BATRM-0086-1G	1	1B2345086-1G	N <MDD>
EXPLODED	U0023	Center speaker terminal PC Board ass'y	BATRM-0086-1H	1	1B2345086-1H	N <MMA>
EXPLODED	U0024	Power amp. Input circuit PC Board ass'y	BACLA-0087-1G	1	1B2345087-1G	N <MDD>
EXPLODED	U0024	Power amp. Input circuit PC Board ass'y	BACLA-0087-1H	1	1B2345087-1H	N <MMA>
EXPLODED	<b>U003</b>	<b>U0030 + U0031 + U0032 + U0033</b>	<b>BADG-0099-1K *</b>	<b>1</b>	<b>1B234599-1K</b>	<b>N &lt;MDD&gt;</b>
EXPLODED	<b>U003</b>	<b>U0030 + U0031 + U0032 + U0033</b>	<b>BADG-0099-1L *</b>	<b>1</b>	<b>1B234599-1L</b>	<b>N &lt;MMA&gt;</b>
EXPLODED	U0030	DAC/ DIR circuit PC Board ass'y	BADG-0099-1K	1	1B2345099-1K	N <MDD>
EXPLODED	U0030	DAC/ DIR circuit PC Board ass'y	BADG-0099-1L	1	1B2345099-1L	N <MMA>
EXPLODED	U0031	CPU Circuit PC Board ass'y	BACPU-0100-1K	1	1B2345100-1K	N <MDD>
EXPLODED	U0031	CPU Circuit PC Board ass'y	BACPU-0100-1L	1	1B2345100-1L	N <MMA>
EXPLODED	U0032	Video circuit PC Board ass'y	BAVD-0101-1K	1	1B2345101-1K	N <MDD>
EXPLODED	U0032	Video circuit PC Board ass'y	BAVD-0101-1L	1	1B2345101-1L	N <MMA>
EXPLODED	U0033	Universal port PC Board ass'y	BAETC-0103-1K	1	---	N NSP, <MDD>
EXPLODED	U0033	Universal port PC Board ass'y	BAETC-0103-1L	1	---	N NSP, <MMA>
EXPLODED	<b>U004</b>	<b>U0040 + U0041 + U0042 + U0043 +</b>	<b>BADIS-0121-1A *</b>	<b>1</b>	<b>1B234521-1A</b>	<b>N</b>
EXPLODED		<b>U0044 + U0045</b>				
EXPLODED	U0040	Display circuit PC Board ass'y	BADIS-0121-1A	1	1B2345121-1A	N
EXPLODED	U0041	Standby switch PC Board ass'y	BASW-0122-1A	1	1B2345122-1A	N
EXPLODED	U0042	Headphone terminal PC Board ass'y	BAETC-0123-1A	1	---	N NSP
EXPLODED	U0043	Front digital input PC Board ass'y	BAETC-0124-1A	1	---	N NSP
EXPLODED	U0044	Volume PC Board ass'y	BAETC-0125-1A	1	---	N NSP
EXPLODED	U0045	Fuse PC Board ass'y	BAPS-0126-1A	1	1B2345126-1A	N
EXPLODED	U0046	Support PC board-1	BAETC-0127-1A	1	---	N NSP
EXPLODED	U0047	Support PC board-2	BAETC-0128-1A	1	---	N NSP
EXPLODED	U0048	Support PC board-3	BAETC-0129-1A	1	---	N NSP
EXPLODED	U0049	FFC Support PC board	BAETC-0130-1A	1	---	N NSP
EXPLODED	<b>U005</b>	<b>HDMI circuit PC Board ass'y</b>	<b>BAHDM-0132-1E *</b>	<b>1</b>	<b>1B234532-1E</b>	<b>N</b>
EXPLODED	U0061	Front HDMI terminal PC Board ass'y	BAHDM-0291-1B	1	1B2345291-1B	N
EXPLODED	U011	TUNER UNIT	FAEH06-E01EX	1	240165	<MMA>
EXPLODED	U011	TUNER UNIT	FAEH06-A01US	1	240166	<MDD>

DTR-50.1

## PC BOARD PARTS LIST

PCB U001	<b>U0010</b>	POWER AMPLIFIER PC BOARD (BAAMP-0072-1K)
PCB U001	<b>U0011</b>	AUDIO INPUT CIRCUIT PC BOARD (BAASP-0073-1K)
PCB U001	<b>U0012</b>	THERMISTER PC BOARD (BAETC-0074-1K)
PCB U001	<b>U0013</b>	CONNECTION BOARD (BAETC-0075-1K)
PCB U001	<b>U0014</b>	AC INLET TERMINAL PC BOARD (BAETC-0089-1K)

PCB U001	CIRCUIT. NO.	PART NAME	DESCRIPTION	Q'TY	PART NO. (SN)	REMARKS
PCB U001	<b>[TUNER UNIT]</b>					
PCB U001	Q4607	PHT CP	PS2501AL-1	1	24120141R2	
PCB U001	Q4608	PHT CP	PS2501AL-1	1	24120141R2	
PCB U001	<b>[SEMI CONDUCTOR]</b>					
PCB U001	D4600	C-DIODE	1SS352	1	223234R2	
PCB U001	D4601	C-DIODE	1SS352	1	223234R2	
PCB U001	D4602	C-DIODE	1SS352	1	223234R2	
PCB U001	D4603	C-DIODE	1SS352	1	223234R2	
PCB U001	D4604	C-DIODE	1SS352	1	223234R2	
PCB U001	D4605	C-DIODE	1SS352	1	223234R2	
PCB U001	D4606	DIODE	RL1N4003	1	22380260T	
PCB U001	D5500	ZENER D	MTZJ7.5B	1	224470752T	
PCB U001	D5501	ZENER D	MTZJ7.5B	1	224470752T	
PCB U001	D5502	ZENER D	MTZJ3.6B	1	224470362T	
PCB U001	D5507	C-DIODE	1SS352	1	223234R2	
PCB U001	D5507 or	C-DIODE	1SS355	(1)	223269R2	
PCB U001	D5507 or	C-DIODE	KDS4148U	(1)	223283R2	
PCB U001	D5507 or	C-DIODE	MA2J1110GL	(1)	223302R2	
PCB U001	D5508	C-DIODE	1SS352	1	223234R2	
PCB U001	D5508 or	C-DIODE	1SS355	(1)	223269R2	
PCB U001	D5508 or	C-DIODE	KDS4148U	(1)	223283R2	
PCB U001	D5508 or	C-DIODE	MA2J1110GL	(1)	223302R2	
PCB U001	D5511	C-DIODE	1SS352	1	223234R2	
PCB U001	D5512	C-DIODE	1SS352	1	223234R2	
PCB U001	D5513	C-DIODE	1SS352	1	223234R2	
PCB U001	D5514	C-DIODE	1SS352	1	223234R2	
PCB U001	D5517	C-DIODE	1SS352	1	223234R2	
PCB U001	D5517 or	C-DIODE	1SS355	(1)	223269R2	
PCB U001	D5517 or	C-DIODE	KDS4148U	(1)	223283R2	
PCB U001	D5517 or	C-DIODE	MA2J1110GL	(1)	223302R2	

PCB U001	D5518	C-DIODE	1SS352	1	223234R2
PCB U001	D5518 or	C-DIODE	1SS355	(1)	223269R2
PCB U001	D5518 or	C-DIODE	KDS4148U	(1)	223283R2
PCB U001	D5518 or	C-DIODE	MA2J1110GL	(1)	223302R2
PCB U001	D5520	C-DIODE	1SS352	1	223234R2
PCB U001	D5521	ZENER D	UDZS8.2B	1	224550820R2
PCB U001	D5522	ZENER D	UDZS3.6B	1	224550360R2
PCB U001	D5523	C-DIODE	1SS352	1	223234R2
PCB U001	D5601	C-DIODE	S1NB60-4062	1	22380318R2
PCB U001	D6000	C-DIODE	1SS352	1	223234R2
PCB U001	D6000 or	C-DIODE	1SS355	(1)	223269R2
PCB U001	D6000 or	C-DIODE	KDS4148U	(1)	223283R2
PCB U001	D6000 or	C-DIODE	MA2J1110GL	(1)	223302R2
PCB U001	D6001	C-DIODE	1SS352	1	223234R2
PCB U001	D6001 or	C-DIODE	1SS355	(1)	223269R2
PCB U001	D6001 or	C-DIODE	KDS4148U	(1)	223283R2
PCB U001	D6001 or	C-DIODE	MA2J1110GL	(1)	223302R2
PCB U001	D6002	C-DIODE	1SS352	1	223234R2
PCB U001	D6002 or	C-DIODE	1SS355	(1)	223269R2
PCB U001	D6002 or	C-DIODE	KDS4148U	(1)	223283R2
PCB U001	D6002 or	C-DIODE	MA2J1110GL	(1)	223302R2
PCB U001	D6003	C-DIODE	1SS352	1	223234R2
PCB U001	D6003 or	C-DIODE	1SS355	(1)	223269R2
PCB U001	D6003 or	C-DIODE	KDS4148U	(1)	223283R2
PCB U001	D6003 or	C-DIODE	MA2J1110GL	(1)	223302R2
PCB U001	D6004	C-DIODE	1SS352	1	223234R2
PCB U001	D6004 or	C-DIODE	1SS355	(1)	223269R2
PCB U001	D6004 or	C-DIODE	KDS4148U	(1)	223283R2
PCB U001	D6004 or	C-DIODE	MA2J1110GL	(1)	223302R2
PCB U001	D6005	C-DIODE	1SS352	1	223234R2
PCB U001	D6005 or	C-DIODE	1SS355	(1)	223269R2
PCB U001	D6005 or	C-DIODE	KDS4148U	(1)	223283R2
PCB U001	D6005 or	C-DIODE	MA2J1110GL	(1)	223302R2
PCB U001	D6006	C-DIODE	1SS352	1	223234R2
PCB U001	D6006 or	C-DIODE	1SS355	(1)	223269R2
PCB U001	D6006 or	C-DIODE	KDS4148U	(1)	223283R2
PCB U001	D6006 or	C-DIODE	MA2J1110GL	(1)	223302R2
PCB U001	D6701	C-DIODE	1SS352	1	223234R2
PCB U001	D6701 or	C-DIODE	1SS355	(1)	223269R2
PCB U001	D6701 or	C-DIODE	KDS4148U	(1)	223283R2
PCB U001	D6701 or	C-DIODE	MA2J1110GL	(1)	223302R2

PCB U001	D6702	C-DIODE	1SS352	1	223234R2	
PCB U001	D6702 or	C-DIODE	1SS355	(1)	223269R2	
PCB U001	D6702 or	C-DIODE	KDS4148U	(1)	223283R2	
PCB U001	D6702 or	C-DIODE	MA2J1110GL	(1)	223302R2	
PCB U001	D6703	ZENER D	UDZS3.6B	1	224550360R2	
PCB U001	D6704	ZENER D	UDZS3.6B	1	224550360R2	
PCB U001	D6713	ZENER D	UDZS3.6B	1	224550360R2	
PCB U001	D6901	DIODE	D10XB60H	1	22380337	
PCB U001	D6901A	HEAT SINK	RAD-152	1	27160483	
PCB U001	D6901B	TAPE	TAPE(CLOTH-8U)	1	29110082	
PCB U001	D6901C	SCREW	3P+10FN(3BC)	2	82143010GR	
PCB U001	D6902	C-DIODE	1SS352	1	223234R2	
PCB U001	D6902 or	C-DIODE	1SS355	(1)	223269R2	
PCB U001	D6902 or	C-DIODE	KDS4148U	(1)	223283R2	
PCB U001	D6902 or	C-DIODE	MA2J1110GL	(1)	223302R2	
PCB U001	D6903	DIODE	D10XB60H	1	22380337	
PCB U001	Q4600	TR	2SB1240-R	1	2213794T	
PCB U001	Q4601	TR	KRC102S	1	2216190R2	
PCB U001	Q4602	TR	2SA1162-GR	1	2214375R2	
PCB U001	Q4603	TR	KRC102S	1	2216190R2	
PCB U001	Q4604	TR	2SA1162-GR	1	2214375R2	
PCB U001	Q4605	TR	KRC102S	1	2216190R2	
PCB U001	Q4606	TR	KRA102S	1	2216220R2	
PCB U001	Q5501	IC	R2A15220FP	1	22242600R3	N
PCB U001	Q5502	IC	M61540FP	1	22242497R2	
PCB U001	Q5503	IC	NJM4580M-D	1	22241448R2	
PCB U001	Q5600	TR	RN1441	1	2215410R2	
PCB U001	Q5601	TR	RN1441	1	2215410R2	
PCB U001	Q5602	TR	RN1441	1	2215410R2	
PCB U001	Q5603	TR	RN1441	1	2215410R2	
PCB U001	Q5604	TR	RN1441	1	2215410R2	
PCB U001	Q5605	TR	RN1441	1	2215410R2	
PCB U001	Q5606	TR	RN1441	1	2215410R2	
PCB U001	Q5607	TR	RN1441	1	2215410R2	
PCB U001	Q5610	TR	RN1441	1	2215410R2	
PCB U001	Q5611	TR	RN1441	1	2215410R2	
PCB U001	Q5612	TR	RN1441	1	2215410R2	
PCB U001	Q5613	TR	RN1441	1	2215410R2	
PCB U001	Q5614	TR	RN1441	1	2215410R2	
PCB U001	Q5615	TR	RN1441	1	2215410R2	
PCB U001	Q5616	TR	RN1441	1	2215410R2	

PCB U001	Q5617	TR	RN1441	1	2215410R2	
PCB U001	Q5618	IC	NJM4580M-D	1	22241448R2	
PCB U001	Q5630	IC	NJM4580M-D	1	22241448R2	
PCB U001	Q5632	TR	RN1441	1	2215410R2	
PCB U001	Q5633	TR	RN1441	1	2215410R2	
PCB U001	Q5636	TR	RN1441	1	2215410R2	
PCB U001	Q5637	TR	RN1441	1	2215410R2	
PCB U001	Q5640	TR	RN1441	1	2215410R2	
PCB U001	Q5641	TR	RN1441	1	2215410R2	
PCB U001	Q5645	TR	2SC2712-GR	1	2213145R2	
PCB U001	Q5646	TR	2SC2712-GR	1	2213145R2	
PCB U001	Q5647	TR	2SA1162-GR	1	2214375R2	
PCB U001	Q5670	IC	78M15HF(NJM78M15FA)	1	222780155JRC	
PCB U001	Q5670 or	IC	UPC78M15AHF-AZ	(1)	222780155NEC	
PCB U001	Q5670A	HEAT SINK	RAD-252	1	27160641	N
PCB U001	Q5670B	SCREW	3P+10FN(3BC)	2	82143010GR	
PCB U001	Q5671	IC	79M15HF(NJM79M15FA)	1	222790155JRC	
PCB U001	Q5671 or	IC	79M15F(AN79M15F)	(1)	222790155MAT	
PCB U001	Q5671 or	IC	UPC79M15HF-AZ	(1)	222790155NEC	
PCB U001	Q5684	TR	2SC2235-O(TPE6_F)	1	2211653T	
PCB U001	Q5685	TR	2SA965-O(TPE6_F)	1	2211643T	
PCB U001	Q5708	TR	RN1441	1	2215410R2	
PCB U001	Q5709	TR	RN1441	1	2215410R2	
PCB U001	Q5903	TR	RN1441	1	2215410R2	
PCB U001	Q5904	TR	RN1441	1	2215410R2	
PCB U001	Q6000	TR	2SC1740S-S	1	2213285T	
PCB U001	Q6001	TR	2SC1740S-S	1	2213285T	
PCB U001	Q6002	TR	2SC1740S-S	1	2213285T	
PCB U001	Q6003	TR	2SC1740S-S	1	2213285T	
PCB U001	Q6004	TR	2SC1740S-S	1	2213285T	
PCB U001	Q6005	TR	2SC1740S-S	1	2213285T	
PCB U001	Q6006	TR	2SC1740S-S	1	2213285T	
PCB U001	Q6010	TR	2SC1740S-S	1	2213285T	
PCB U001	Q6011	TR	2SC1740S-S	1	2213285T	
PCB U001	Q6012	TR	2SC1740S-S	1	2213285T	
PCB U001	Q6013	TR	2SC1740S-S	1	2213285T	
PCB U001	Q6014	TR	2SC1740S-S	1	2213285T	
PCB U001	Q6015	TR	2SC1740S-S	1	2213285T	
PCB U001	Q6016	TR	2SC1740S-S	1	2213285T	
PCB U001	Q6030	TR	2SC2229-Y(TPE6_F)	1	2211634T	
PCB U001	Q6030 or	TR	2SC2229-O(TPE6_F)	(1)	2211633T	

PCB U001	Q6031	TR	2SC2229-Y(TPE6_F)	1	2211634T
PCB U001	Q6031 or	TR	2SC2229-O(TPE6_F)	(1)	2211633T
PCB U001	Q6032	TR	2SC2229-Y(TPE6_F)	1	2211634T
PCB U001	Q6032 or	TR	2SC2229-O(TPE6_F)	(1)	2211633T
PCB U001	Q6033	TR	2SC2229-Y(TPE6_F)	1	2211634T
PCB U001	Q6033 or	TR	2SC2229-O(TPE6_F)	(1)	2211633T
PCB U001	Q6034	TR	2SC2229-Y(TPE6_F)	1	2211634T
PCB U001	Q6034 or	TR	2SC2229-O(TPE6_F)	(1)	2211633T
PCB U001	Q6035	TR	2SC2229-Y(TPE6_F)	1	2211634T
PCB U001	Q6035 or	TR	2SC2229-O(TPE6_F)	(1)	2211633T
PCB U001	Q6036	TR	2SC2229-Y(TPE6_F)	1	2211634T
PCB U001	Q6036 or	TR	2SC2229-O(TPE6_F)	(1)	2211633T
PCB U001	Q6040	TR	2SA949-O(TPE6_F)	1	2211353T
PCB U001	Q6040 or	TR	2SA949-Y(TPE6_F)	(1)	2211354T
PCB U001	Q6041	TR	2SA949-O(TPE6_F)	1	2211353T
PCB U001	Q6041 or	TR	2SA949-Y(TPE6_F)	(1)	2211354T
PCB U001	Q6042	TR	2SA949-O(TPE6_F)	1	2211353T
PCB U001	Q6042 or	TR	2SA949-Y(TPE6_F)	(1)	2211354T
PCB U001	Q6043	TR	2SA949-O(TPE6_F)	1	2211353T
PCB U001	Q6043 or	TR	2SA949-Y(TPE6_F)	(1)	2211354T
PCB U001	Q6044	TR	2SA949-O(TPE6_F)	1	2211353T
PCB U001	Q6044 or	TR	2SA949-Y(TPE6_F)	(1)	2211354T
PCB U001	Q6045	TR	2SA949-O(TPE6_F)	1	2211353T
PCB U001	Q6045 or	TR	2SA949-Y(TPE6_F)	(1)	2211354T
PCB U001	Q6046	TR	2SA949-O(TPE6_F)	1	2211353T
PCB U001	Q6046 or	TR	2SA949-Y(TPE6_F)	(1)	2211354T
PCB U001	Q6070	TR	2SC2229-O(TPE6_F)	1	2211633T
PCB U001	Q6070 or	TR	2SC2229-Y(TPE6_F)	(1)	2211634T
PCB U001	Q6071	TR	2SC2229-O(TPE6_F)	1	2211633T
PCB U001	Q6071 or	TR	2SC2229-Y(TPE6_F)	(1)	2211634T
PCB U001	Q6072	TR	2SC2229-O(TPE6_F)	1	2211633T
PCB U001	Q6072 or	TR	2SC2229-Y(TPE6_F)	(1)	2211634T
PCB U001	Q6073	TR	2SC2229-O(TPE6_F)	1	2211633T
PCB U001	Q6073 or	TR	2SC2229-Y(TPE6_F)	(1)	2211634T
PCB U001	Q6074	TR	2SC2229-O(TPE6_F)	1	2211633T
PCB U001	Q6074 or	TR	2SC2229-Y(TPE6_F)	(1)	2211634T
PCB U001	Q6075	TR	2SC2229-O(TPE6_F)	1	2211633T
PCB U001	Q6075 or	TR	2SC2229-Y(TPE6_F)	(1)	2211634T
PCB U001	Q6076	TR	2SC2229-O(TPE6_F)	1	2211633T
PCB U001	Q6076 or	TR	2SC2229-Y(TPE6_F)	(1)	2211634T
PCB U001	Q6100	TR	2SA1930(ONK_Q)	1	2203000



PCB U001	Q6100 or	TR	2SA2140-Q_P	(1)	2217151
PCB U001	Q6101	TR	2SA1930(ONK_Q)	1	2203000
PCB U001	Q6101 or	TR	2SA2140-Q_P	(1)	2217151
PCB U001	Q6102	TR	2SA1930(ONK_Q)	1	2203000
PCB U001	Q6102 or	TR	2SA2140-Q_P	(1)	2217151
PCB U001	Q6103	TR	2SA1930(ONK_Q)	1	2203000
PCB U001	Q6103 or	TR	2SA2140-Q_P	(1)	2217151
PCB U001	Q6104	TR	2SA1930(ONK_Q)	1	2203000
PCB U001	Q6104 or	TR	2SA2140-Q_P	(1)	2217151
PCB U001	Q6105	TR	2SA1930(ONK_Q)	1	2203000
PCB U001	Q6105 or	TR	2SA2140-Q_P	(1)	2217151
PCB U001	Q6106	TR	2SA1930(ONK_Q)	1	2203000
PCB U001	Q6106 or	TR	2SA2140-Q_P	(1)	2217151
PCB U001	Q6110	TR	2SC5171(ONK_Q)	1	2203010
PCB U001	Q6110 or	TR	2SC5993-Q_P	(1)	2217161
PCB U001	Q6111	TR	2SC5171(ONK_Q)	1	2203010
PCB U001	Q6111 or	TR	2SC5993-Q_P	(1)	2217161
PCB U001	Q6112	TR	2SC5171(ONK_Q)	1	2203010
PCB U001	Q6112 or	TR	2SC5993-Q_P	(1)	2217161
PCB U001	Q6113	TR	2SC5171(ONK_Q)	1	2203010
PCB U001	Q6113 or	TR	2SC5993-Q_P	(1)	2217161
PCB U001	Q6114	TR	2SC5171(ONK_Q)	1	2203010
PCB U001	Q6114 or	TR	2SC5993-Q_P	(1)	2217161
PCB U001	Q6115	TR	2SC5171(ONK_Q)	1	2203010
PCB U001	Q6115 or	TR	2SC5993-Q_P	(1)	2217161
PCB U001	Q6116	TR	2SC5171(ONK_Q)	1	2203010
PCB U001	Q6116 or	TR	2SC5993-Q_P	(1)	2217161
PCB U001	Q6380	IC	LM61CIZ	1	22242212
PCB U001	Q6380A	RETAINER	(PTH)	1	27141884-1
PCB U001	Q6701	TR	2SC2712-GR	1	2213145R2
PCB U001	Q6701 or	TR	KTC3875-GR	(1)	2216175R2
PCB U001	Q6702	TR	2SC2712-GR	1	2213145R2
PCB U001	Q6702 or	TR	KTC3875-GR	(1)	2216175R2
PCB U001	Q6703	TR	2SA1163-BL(TE85L_F)	1	2216756R2
PCB U001	Q6707	TR	2SC2712-GR	1	2213145R2
PCB U001	Q6707 or	TR	KTC3875-GR	(1)	2216175R2
PCB U001	Q6713	TR	2SA1163-BL(TE85L_F)	1	2216756R2
PCB U001	<b>[TRANS COIL]</b>				
PCB U001	L4600	EMIFIL	BK1608LM182-T	1	230958R1
PCB U001	L4601	EMIFIL	BK1608LM182-T	1	230958R1
PCB U001	L4602	EMIFIL	BK1608LM182-T	1	230958R1

PCB U001	L4603	EMIFIL	BK1608LM182-T	1	230958R1
PCB U001	L6000	FR CORE	*	1	5597-45502
PCB U001	L6001	FR CORE	*	1	5597-45502
PCB U001	L6002	FR CORE	*	1	5597-45502
PCB U001	L6003	FR CORE	*	1	5597-45502
PCB U001	L6004	FR CORE	*	1	5597-45502
PCB U001	L6005	FR CORE	*	1	5597-45502
PCB U001	L6006	FR CORE	*	1	5597-45502
PCB U001	L6010	FR CORE	*	1	5597-45502
PCB U001	L6011	FR CORE	*	1	5597-45502
PCB U001	L6012	FR CORE	*	1	5597-45502
PCB U001	L6013	FR CORE	*	1	5597-45502
PCB U001	L6014	FR CORE	*	1	5597-45502
PCB U001	L6015	FR CORE	*	1	5597-45502
PCB U001	L6016	FR CORE	*	1	5597-45502
PCB U001	<b>[CAPACITOR]</b>				
PCB U001	C4602	C-CERA C	CC725CH1H-101J1	1	342101014R1
PCB U001	C4604	C-CERA C	CC725CH1H-101J1	1	342101014R1
PCB U001	C4605	C-CERA C	CK725F1E-104Z1	1	332161040R1
PCB U001	C5503	UPZ C	2AUPZTF221JE	1	376332214T
PCB U001	C5504	UPZ C	2AUPZTF221JE	1	376332214T
PCB U001	C5505	C-CERA C	CC725CH1H-221J1	1	342102214R1
PCB U001	C5506	C-CERA C	CC725CH1H-221J1	1	342102214R1
PCB U001	C5507	C-CERA C	CC725CH1H-221J1	1	342102214R1
PCB U001	C5508	C-CERA C	CC725CH1H-221J1	1	342102214R1
PCB U001	C5509	C-CERA C	CC725CH1H-221J1	1	342102214R1
PCB U001	C5510	C-CERA C	CC725CH1H-221J1	1	342102214R1
PCB U001	C5511	C-CERA C	CC725CH1H-221J1	1	342102214R1
PCB U001	C5512	C-CERA C	CC725CH1H-221J1	1	342102214R1
PCB U001	C5513	C-CERA C	CC725CH1H-221J1	1	342102214R1
PCB U001	C5514	C-CERA C	CC725CH1H-221J1	1	342102214R1
PCB U001	C5515	C-CERA C	CC725CH1H-221J1	1	342102214R1
PCB U001	C5516	C-CERA C	CC725CH1H-221J1	1	342102214R1
PCB U001	C5517	UTSP C	CE04W10V-470M(UTSP)	1	397534717T
PCB U001	C5518	UTSP C	CE04W10V-470M(UTSP)	1	397534717T
PCB U001	C5519	UPZ C	2AUPZTF221JE	1	376332214T
PCB U001	C5520	UPZ C	2AUPZTF221JE	1	376332214T
PCB U001	C5527	C-CERA C	CC725CH1H-221J1	1	342102214R1
PCB U001	C5528	C-CERA C	CC725CH1H-221J1	1	342102214R1
PCB U001	C5529	C-CERA C	CC725CH1H-221J1	1	342102214R1
PCB U001	C5530	C-CERA C	CC725CH1H-221J1	1	342102214R1

PCB U001	C5531	C-CERA C	CC725CH1H-221J1	1	342102214R1
PCB U001	C5532	C-CERA C	CC725CH1H-221J1	1	342102214R1
PCB U001	C5533	C-CERA C	CC725CH1H-221J1	1	342102214R1
PCB U001	C5534	C-CERA C	CC725CH1H-221J1	1	342102214R1
PCB U001	C5535	UTSP C	CE04W25V-47M(UTSP)	1	397554707T
PCB U001	C5536	UTSP C	CE04W25V-47M(UTSP)	1	397554707T
PCB U001	C5540	UTSP C	CE04W50V-10M(UTSP)	1	397581007T
PCB U001	C5541	UTSP C	CE04W50V-10M(UTSP)	1	397581007T
PCB U001	C5542	UTSP C	CE04W50V-10M(UTSP)	1	397581007T
PCB U001	C5543	UTSP C	CE04W50V-10M(UTSP)	1	397581007T
PCB U001	C5548	C-CERA C	CK725F1E-104Z1	1	332161040R1
PCB U001	C5549	C-CERA C	CK725F1E-104Z1	1	332161040R1
PCB U001	C5550	C-CERA C	CK725B1H-152K1	1	332101525R1
PCB U001	C5551	C-CERA C	CK725B1H-152K1	1	332101525R1
PCB U001	C5555	UTSP C	CE04W25V-47M(UTSP)	1	397554707T
PCB U001	C5559	TF C	ECQ-V50V-473J	1	374724734T
PCB U001	C5560	TF C	ECQ-V50V-473J	1	374724734T
PCB U001	C5561	TF C	ECQ-V50V-224J	1	374722244T
PCB U001	C5562	TF C	ECQ-V50V-224J	1	374722244T
PCB U001	C5563	TF C	ECQ-V50V-223J	1	374722234T
PCB U001	C5564	TF C	ECQ-V50V-223J	1	374722234T
PCB U001	C5569	UTSP C	CE04W50V 47M(UTSP)	1	397584707T
PCB U001	C5570	UTSP C	CE04W50V 47M(UTSP)	1	397584707T
PCB U001	C5571	UTSP C	CE04W50V 47M(UTSP)	1	397584707T
PCB U001	C5572	UTSP C	CE04W50V 47M(UTSP)	1	397584707T
PCB U001	C5573	UTSP C	CE04W50V 47M(UTSP)	1	397584707T
PCB U001	C5574	UTSP C	CE04W50V 47M(UTSP)	1	397584707T
PCB U001	C5575	UTSP C	CE04W50V 47M(UTSP)	1	397584707T
PCB U001	C5576	UTSP C	CE04W50V 47M(UTSP)	1	397584707T
PCB U001	C5579	C-CERA C	CC725CH1H-102J1	1	342101024R1
PCB U001	C5580	UTSP C	CE04W10V-470M(UTSP)	1	397534717T
PCB U001	C5581	UTSP C	CE04W10V-470M(UTSP)	1	397534717T
PCB U001	C5582	C-CERA C	CC725CH1H-102J1	1	342101024R1
PCB U001	C5583	C-CERA C	CC725CH1H-102J1	1	342101024R1
PCB U001	C5584	UTSP C	CE04W25V-47M(UTSP)	1	397554707T
PCB U001	C5585	UTSP C	CE04W25V-47M(UTSP)	1	397554707T
PCB U001	C5586	UTSP C	CE04W10V-220M(UTSP)	1	397532217T
PCB U001	C5587	UTSP C	CE04W10V-220M(UTSP)	1	397532217T
PCB U001	C5588	TF C	ECQ-V50V-123J	1	374721234T
PCB U001	C5589	TF C	ECQ-V50V-123J	1	374721234T
PCB U001	C5590	C-CERA C	CC725CH1H-101J1	1	342101014R1

PCB U001	C5591	C-CERA C	CC725CH1H-101J1	1	342101014R1
PCB U001	C5592	MKT C	B32529C0332J289	1	376493324T
PCB U001	C5593	MKT C	B32529C0332J289	1	376493324T
PCB U001	C5594	C-CERA C	CC725CH1H-101J1	1	342101014R1
PCB U001	C5595	C-CERA C	CC725CH1H-101J1	1	342101014R1
PCB U001	C5596	UTSP C	CE04W50V-10M(UTSP)	1	397581007T
PCB U001	C5597	UTSP C	CE04W50V-10M(UTSP)	1	397581007T
PCB U001	C5598	C-CERA C	CC725CH1H-102J1	1	342101024R1
PCB U001	C5600	UTSP C	CE04W50V 47M(UTSP)	1	397584707T
PCB U001	C5601	UTSP C	CE04W50V 47M(UTSP)	1	397584707T
PCB U001	C5602	UTSP C	CE04W50V 47M(UTSP)	1	397584707T
PCB U001	C5603	UTSP C	CE04W50V 47M(UTSP)	1	397584707T
PCB U001	C5604	UTSP C	CE04W50V 47M(UTSP)	1	397584707T
PCB U001	C5605	UTSP C	CE04W50V 47M(UTSP)	1	397584707T
PCB U001	C5606	UTSP C	CE04W50V 47M(UTSP)	1	397584707T
PCB U001	C5607	UTSP C	CE04W50V 47M(UTSP)	1	397584707T
PCB U001	C5608	C-FILM C	ECHU50V-561J	1	373025614R2
PCB U001	C5609	C-FILM C	ECHU50V-561J	1	373025614R2
PCB U001	C5610	UTSP C	CE04W50V 47M(UTSP)	1	397584707T
PCB U001	C5611	UTSP C	CE04W50V 47M(UTSP)	1	397584707T
PCB U001	C5612	UTSP C	CE04W50V 47M(UTSP)	1	397584707T
PCB U001	C5613	UTSP C	CE04W50V 47M(UTSP)	1	397584707T
PCB U001	C5614	UTSP C	CE04W50V 47M(UTSP)	1	397584707T
PCB U001	C5615	UTSP C	CE04W50V 47M(UTSP)	1	397584707T
PCB U001	C5630	UTSP C	CE04W50V 47M(UTSP)	1	397584707T
PCB U001	C5631	C-CERA C	CC725CH1H-221J1	1	342102214R1
PCB U001	C5632	TF C	ECQ-V50V-103J	1	374721034T
PCB U001	C5660	MMT C	MMT50V-334J	1	375523344T
PCB U001	C5661	VR C	CE04W50V-470M(VR)	1	394684717S
PCB U001	C5662	VR C	CE04W50V-1000M(VR)	1	394681027S
PCB U001	C5666	UTSP C	CE04W25V-220M(UTSP)	1	397552217T
PCB U001	C5667	UTSP C	CE04W25V-220M(UTSP)	1	397552217T
PCB U001	C5670	UTSP C	CE04W50V 47M(UTSP)	1	397584707T
PCB U001	C5671	UTSP C	CE04W50V-220M(UTSP)	1	397582217T
PCB U001	C5672	UTSP C	CE04W50V-10M(UTSP)	1	397581007T
PCB U001	C5673	UTSP C	CE04W50V-10M(UTSP)	1	397581007T
PCB U001	C5674	UTSP C	CE04W10V-470M(UTSP)	1	397534717T
PCB U001	C5675	UTSP C	CE04W10V-470M(UTSP)	1	397534717T
PCB U001	C5677	UTSP C	CE04W25V-220M(UTSP)	1	397552217T
PCB U001	C5679	UTSP C	CE04W50V 47M(UTSP)	1	397584707T
PCB U001	C5680	UTSP C	CE04W50V 47M(UTSP)	1	397584707T

PCB U001	C5684	UTSP C	CE04W25V-220M(UTSP)	1	397552217T
PCB U001	C5685	UTSP C	CE04W25V-220M(UTSP)	1	397552217T
PCB U001	C5686	UTSP C	CE04W25V-220M(UTSP)	1	397552217T
PCB U001	C5687	UTSP C	CE04W25V-220M(UTSP)	1	397552217T
PCB U001	C5689	TF C	ECQ-V50V-333J	1	374723334T
PCB U001	C5690	TF C	ECQ-V50V-333J	1	374723334T
PCB U001	C5691	TF C	ECQ-V50V-473J	1	374724734T
PCB U001	C5692	TF C	ECQ-V50V-224J	1	374722244T
PCB U001	C5693	TF C	ECQ-V50V-473J	1	374724734T
PCB U001	C5694	TF C	ECQ-V50V-224J	1	374722244T
PCB U001	C5695	UTSP C	CE04W50V 47M(UTSP)	1	397584707T
PCB U001	C5696	UTSP C	CE04W50V 47M(UTSP)	1	397584707T
PCB U001	C5697	UTSP C	CE04W50V 47M(UTSP)	1	397584707T
PCB U001	C5698	UTSP C	CE04W50V 47M(UTSP)	1	397584707T
PCB U001	C5707	C-CERA C	CC725CH1H-221J1	1	342102214R1
PCB U001	C5708	C-CERA C	CC725CH1H-221J1	1	342102214R1
PCB U001	C5709	C-CERA C	CC725CH1H-221J1	1	342102214R1
PCB U001	C5720	UTSP C	CE04W50V 47M(UTSP)	1	397584707T
PCB U001	C5721	UTSP C	CE04W50V 47M(UTSP)	1	397584707T
PCB U001	C5722	C-CERA C	CC725CH1H-221J1	1	342102214R1
PCB U001	C5723	C-CERA C	CC725CH1H-221J1	1	342102214R1
PCB U001	C5724	C-CERA C	CC725CH1H-221J1	1	342102214R1
PCB U001	C5738	UTSP C	CE04W10V-100M(UTSP)	1	397531017T
PCB U001	C5739	UTSP C	CE04W25V-220M(UTSP)	1	397552217T
PCB U001	C5905	UTSP C	CE04W50V 47M(UTSP)	1	397584707T
PCB U001	C5906	UTSP C	CE04W50V 47M(UTSP)	1	397584707T
PCB U001	C5907	C-CERA C	CC725CH1H-221J1	1	342102214R1
PCB U001	C5908	C-CERA C	CC725CH1H-221J1	1	342102214R1
PCB U001	C5910	C-CERA C	CK725B1H-152K1	1	332101525R1
PCB U001	C5911	C-CERA C	CK725B1H-152K1	1	332101525R1
PCB U001	C6020	UTSP C	CE04W50V 47M(UTSP)	1	397584707T
PCB U001	C6021	UTSP C	CE04W50V 47M(UTSP)	1	397584707T
PCB U001	C6022	UTSP C	CE04W50V 47M(UTSP)	1	397584707T
PCB U001	C6023	UTSP C	CE04W50V 47M(UTSP)	1	397584707T
PCB U001	C6024	UTSP C	CE04W50V 47M(UTSP)	1	397584707T
PCB U001	C6025	UTSP C	CE04W50V 47M(UTSP)	1	397584707T
PCB U001	C6026	UTSP C	CE04W50V 47M(UTSP)	1	397584707T
PCB U001	C6050	TF C	ECQ-V50V-104J	1	374721044T
PCB U001	C6051	TF C	ECQ-V50V-104J	1	374721044T
PCB U001	C6052	TF C	ECQ-V50V-104J	1	374721044T
PCB U001	C6053	TF C	ECQ-V50V-104J	1	374721044T

PCB U001	C6054	TF C	ECQ-V50V-104J	1	374721044T
PCB U001	C6055	TF C	ECQ-V50V-104J	1	374721044T
PCB U001	C6056	TF C	ECQ-V50V-104J	1	374721044T
PCB U001	C6701	UTSP C	CE04W10V-220M(UTSP)	1	397532217T
PCB U001	C6703	C-CERA C	CK725F1H-104Z1	1	332151040R1
PCB U001	C6704	UTSP C	CE04W50V-1M(UTSP)	1	397580107T
PCB U001	C6706	UTSP C	CE04W25V-47M(UTSP)	1	397554707T
PCB U001	C6710	C-CERA C	CK725F1A-105Z1	1	332181050R1
PCB U001	C6713	C-CERA C	CK725F1H-104Z1	1	332151040R1
PCB U001	C6714	UTSP C	CE04W50V-2.2M(UTSP)	1	397580227T
PCB U001	C6901	ELECT C	CE69W71V-15000M	1	3504467
PCB U001	C6902	ELECT C	CE69W71V-15000M	1	3504467
PCB U001	C6911	C-CERA C	CC725CH1H-102J1	1	342101024R1
PCB U001	C6912	TF C	ECQ-V100V-334J	1	374733344T
PCB U001	C6913	TF C	ECQ-V100V-334J	1	374733344T
PCB U001	C6915	TF C	ECQ-V50V-104J	1	374721044T
PCB U001	C6916	TF C	ECQ-V50V-104J	1	374721044T
PCB U001	[RESISTOR]				
PCB U001	R4600	C-CARBON R	RN72K1J-039JE	1	435030394R1
PCB U001	R4601	C-CARBON R	RN72K1J-224JE	1	435032244R1
PCB U001	R4602	C-CARBON R	RN72K1J-102JE	1	435031024R1
PCB U001	R4603	C-CARBON R	RN72K1J-220JE	1	435032204R1
PCB U001	R4604	C-CARBON R	RN72K1J-101JE	1	435031014R1
PCB U001	R4605	C-CARBON R	RN72K1J-224JE	1	435032244R1
PCB U001	R4606	C-CARBON R	RN72K1J-102JE	1	435031024R1
PCB U001	R4607	C-CARBON R	RN72K1J-220JE	1	435032204R1
PCB U001	R4608	C-CARBON R	RN72K1J-101JE	1	435031014R1
PCB U001	R4609	C-CARBON R	RN72K1J-000JE	1	435030004R1
PCB U001	R4610	C-CARBON R	RN72K1J-224JE	1	435032244R1
PCB U001	R4611	C-CARBON R	RN72K1J-000JE	1	435030004R1
PCB U001	R4613	C-CARBON R	RN72K1J-102JE	1	435031024R1
PCB U001	R4617	C-CARBON R	RN72K1J-470JE	1	435034704R1
PCB U001	R4618	C-CARBON R	RN72K1J-470JE	1	435034704R1
PCB U001	R4619	C-CARBON R	RN72K1J-000JE	1	435030004R1
PCB U001	R4620	C-CARBON R	RN72K1J-101JE	1	435031014R1
PCB U001	R4621	C-CARBON R	RN72K1J-103JE	1	435031034R1
PCB U001	R5503	C-CARBON R	RN72K1J-331JE	1	435033314R1
PCB U001	R5504	C-CARBON R	RN72K1J-331JE	1	435033314R1
PCB U001	R5505	C-CARBON R	RN72K1J-331JE	1	435033314R1
PCB U001	R5506	C-CARBON R	RN72K1J-331JE	1	435033314R1
PCB U001	R5507	C-CARBON R	RN72K1J-331JE	1	435033314R1

PCB U001	R5508	C-CARBON R	RN72K1J-331JE	1	435033314R1
PCB U001	R5509	C-CARBON R	RN72K1J-331JE	1	435033314R1
PCB U001	R5510	C-CARBON R	RN72K1J-331JE	1	435033314R1
PCB U001	R5511	C-CARBON R	RN72K1J-331JE	1	435033314R1
PCB U001	R5512	C-CARBON R	RN72K1J-331JE	1	435033314R1
PCB U001	R5513	C-CARBON R	RN72K1J-331JE	1	435033314R1
PCB U001	R5514	C-CARBON R	RN72K1J-331JE	1	435033314R1
PCB U001	R5515	C-CARBON R	RN72K1J-331JE	1	435033314R1
PCB U001	R5516	C-CARBON R	RN72K1J-331JE	1	435033314R1
PCB U001	R5517	METAL O R	RS1WBJ-10	1	443621004T
PCB U001	R5518	METAL O R	RS1WBJ-10	1	443621004T
PCB U001	R5519	C-CARBON R	RN72K1J-331JE	1	435033314R1
PCB U001	R5520	C-CARBON R	RN72K1J-331JE	1	435033314R1
PCB U001	R5526	C-CARBON R	RN72K1J-101JE	1	435031014R1
PCB U001	R5527	C-CARBON R	RN72K1J-101JE	1	435031014R1
PCB U001	R5528	C-CARBON R	RN72K1J-101JE	1	435031014R1
PCB U001	R5529	C-CARBON R	RN72K1J-101JE	1	435031014R1
PCB U001	R5530	C-CARBON R	RN72K1J-101JE	1	435031014R1
PCB U001	R5531	C-CARBON R	RN72K1J-101JE	1	435031014R1
PCB U001	R5532	C-CARBON R	RN72K1J-101JE	1	435031014R1
PCB U001	R5533	C-CARBON R	RN72K1J-101JE	1	435031014R1
PCB U001	R5534	C-CARBON R	RN72K1J-101JE	1	435031014R1
PCB U001	R5535	C-CARBON R	RN72K1J-224JE	1	435032244R1
PCB U001	R5538	C-CARBON R	RN72K1J-103JE	1	435031034R1
PCB U001	R5539	C-CARBON R	RN72K1J-103JE	1	435031034R1
PCB U001	R5540	C-CARBON R	RN72K1J-224JE	1	435032244R1
PCB U001	R5543	C-CARBON R	RN72K1J-224JE	1	435032244R1
PCB U001	R5544	C-CARBON R	RN72K1J-224JE	1	435032244R1
PCB U001	R5545	C-CARBON R	RN72K1J-224JE	1	435032244R1
PCB U001	R5546	C-CARBON R	RN72K1J-224JE	1	435032244R1
PCB U001	R5547	C-CARBON R	RN72K1J-224JE	1	435032244R1
PCB U001	R5548	C-CARBON R	RN72K1J-224JE	1	435032244R1
PCB U001	R5549	C-CARBON R	RN72K1J-224JE	1	435032244R1
PCB U001	R5550	C-CARBON R	RN72K1J-224JE	1	435032244R1
PCB U001	R5551	C-CARBON R	RN72K1J-224JE	1	435032244R1
PCB U001	R5552	C-CARBON R	RN72K1J-224JE	1	435032244R1
PCB U001	R5553	C-CARBON R	RN72K1J-224JE	1	435032244R1
PCB U001	R5554	C-CARBON R	RN72K1J-224JE	1	435032244R1
PCB U001	R5555	C-CARBON R	RN72K1J-224JE	1	435032244R1
PCB U001	R5556	C-CARBON R	RN72K1J-224JE	1	435032244R1
PCB U001	R5557	C-CARBON R	RN72K1J-224JE	1	435032244R1

PCB U001	R5558	C-CARBON R	RN72K1J-224JE	1	435032244R1
PCB U001	R5559	C-CARBON R	RN72K1J-224JE	1	435032244R1
PCB U001	R5560	C-CARBON R	RN72K1J-224JE	1	435032244R1
PCB U001	R5561	C-CARBON R	RN72K1J-000JE	1	435030004R1
PCB U001	R5562	C-CARBON R	RN72K1J-000JE	1	435030004R1
PCB U001	R5563	C-CARBON R	RN72K1J-224JE	1	435032244R1
PCB U001	R5564	C-CARBON R	RN72K1J-224JE	1	435032244R1
PCB U001	R5565	C-CARBON R	RN72K1J-224JE	1	435032244R1
PCB U001	R5567	C-CARBON R	RN72K1J-224JE	1	435032244R1
PCB U001	R5568	C-CARBON R	RN72K1J-223JE	1	435032234R1
PCB U001	R5569	C-CARBON R	RN72K1J-224JE	1	435032244R1
PCB U001	R5570	C-CARBON R	RN72K1J-224JE	1	435032244R1
PCB U001	R5571	C-CARBON R	RN72K1J-224JE	1	435032244R1
PCB U001	R5572	C-CARBON R	RN72K1J-224JE	1	435032244R1
PCB U001	R5573	C-CARBON R	RN72K1J-224JE	1	435032244R1
PCB U001	R5574	C-CARBON R	RN72K1J-224JE	1	435032244R1
PCB U001	R5575	C-CARBON R	RN72K1J-224JE	1	435032244R1
PCB U001	R5576	C-CARBON R	RN72K1J-224JE	1	435032244R1
PCB U001	R5577	C-CARBON R	RN72K1J-104JE	1	435031044R1
PCB U001	R5578	C-CARBON R	RN72K1J-104JE	1	435031044R1
PCB U001	R5579	C-CARBON R	RN72K1J-104JE	1	435031044R1
PCB U001	R5580	C-CARBON R	RN72K1J-104JE	1	435031044R1
PCB U001	R5582	C-CARBON R	RN72K1J-224JE	1	435032244R1
PCB U001	R5583	C-CARBON R	RN72K1J-224JE	1	435032244R1
PCB U001	R5585	C-CARBON R	RN72K1J-472JE	1	435034724R1
PCB U001	R5586	C-CARBON R	RN72K1J-472JE	1	435034724R1
PCB U001	R5587	C-CARBON R	RN72K1J-103JE	1	435031034R1
PCB U001	R5588	C-CARBON R	RN72K1J-103JE	1	435031034R1
PCB U001	R5590	C-CARBON R	RN72K1J-223JE	1	435032234R1
PCB U001	R5591	C-CARBON R	RN72K1J-223JE	1	435032234R1
PCB U001	R5592	C-CARBON R	RN72K1J-332JE	1	435033324R1
PCB U001	R5593	C-CARBON R	RN72K1J-332JE	1	435033324R1
PCB U001	R5594	C-CARBON R	RN72K1J-331JE	1	435033314R1
PCB U001	R5595	C-CARBON R	RN72K1J-331JE	1	435033314R1
PCB U001	R5596	C-CARBON R	RN72K1J-123JE	1	435031234R1
PCB U001	R5597	C-CARBON R	RN72K1J-123JE	1	435031234R1
PCB U001	R5598	C-CARBON R	RN72K1J-103JE	1	435031034R1
PCB U001	R5599	C-CARBON R	RN72K1J-103JE	1	435031034R1
PCB U001	R5600	C-CARBON R	RN72K1J-224JE	1	435032244R1
PCB U001	R5601	C-CARBON R	RN72K1J-224JE	1	435032244R1
PCB U001	R5602	C-CARBON R	RN72K1J-224JE	1	435032244R1



PCB U001	R5603	C-CARBON R	RN72K1J-224JE	1	435032244R1
PCB U001	R5604	C-CARBON R	RN72K1J-224JE	1	435032244R1
PCB U001	R5605	C-CARBON R	RN72K1J-224JE	1	435032244R1
PCB U001	R5606	C-CARBON R	RN72K1J-224JE	1	435032244R1
PCB U001	R5607	C-CARBON R	RN72K1J-224JE	1	435032244R1
PCB U001	R5608	C-CARBON R	RN72K1J-224JE	1	435032244R1
PCB U001	R5609	C-CARBON R	RN72K1J-224JE	1	435032244R1
PCB U001	R5610	C-CARBON R	RN72K1J-121JE	1	435031214R1
PCB U001	R5611	C-CARBON R	RN72K1J-121JE	1	435031214R1
PCB U001	R5612	C-CARBON R	RN72K1J-121JE	1	435031214R1
PCB U001	R5613	C-CARBON R	RN72K1J-121JE	1	435031214R1
PCB U001	R5614	C-CARBON R	RN72K1J-121JE	1	435031214R1
PCB U001	R5615	C-CARBON R	RN72K1J-121JE	1	435031214R1
PCB U001	R5616	C-CARBON R	RN72K1J-121JE	1	435031214R1
PCB U001	R5617	C-CARBON R	RN72K1J-121JE	1	435031214R1
PCB U001	R5620	C-CARBON R	RN72K1J-101JE	1	435031014R1
PCB U001	R5621	C-CARBON R	RN72K1J-101JE	1	435031014R1
PCB U001	R5622	C-CARBON R	RN72K1J-101JE	1	435031014R1
PCB U001	R5623	C-CARBON R	RN72K1J-101JE	1	435031014R1
PCB U001	R5624	C-CARBON R	RN72K1J-101JE	1	435031014R1
PCB U001	R5625	C-CARBON R	RN72K1J-101JE	1	435031014R1
PCB U001	R5626	C-CARBON R	RN72K1J-101JE	1	435031014R1
PCB U001	R5627	C-CARBON R	RN72K1J-101JE	1	435031014R1
PCB U001	R5630	C-CARBON R	RN72K1J-221JE	1	435032214R1
PCB U001	R5631	C-CARBON R	RN72K1J-473JE	1	435034734R1
PCB U001	R5632	C-CARBON R	RN72K1J-153JE	1	435031534R1
PCB U001	R5633	C-CARBON R	RN72K1J-122JE	1	435031224R1
PCB U001	R5634	C-CARBON R	RN72K1J-103JE	1	435031034R1
PCB U001	R5635	C-CARBON R	RN72K1J-000JE	1	435030004R1
PCB U001	R5636	C-CARBON R	RN72K1J-000JE	1	435030004R1
PCB U001	R5637	METAL O R	RS1/2WBJ-10	1	443521004T
PCB U001	R5638	METAL O R	RS1/2WBJ-10	1	443521004T
PCB U001	R5639	C-CARBON R	RN72K1J-331JE	1	435033314R1
PCB U001	R5640	C-CARBON R	RN72K1J-331JE	1	435033314R1
PCB U001	R5641	C-CARBON R	RN72K1J-563JE	1	435035634R1
PCB U001	R5642	C-CARBON R	RN72K1J-563JE	1	435035634R1
PCB U001	R5643	C-CARBON R	RN72K1J-474JE	1	435034744R1
PCB U001	R5644	C-CARBON R	RN72K1J-474JE	1	435034744R1
PCB U001	R5645	C-CARBON R	RN72K1J-561JE	1	435035614R1
PCB U001	R5646	C-CARBON R	RN72K1J-561JE	1	435035614R1
PCB U001	R5647	C-CARBON R	RN72K1J-274JE	1	435032744R1

PCB U001	R5648	C-CARBON R	RN72K1J-274JE	1	435032744R1
PCB U001	R5649	C-CARBON R	RN72K1J-223JE	1	435032234R1
PCB U001	R5650	C-CARBON R	RN72K1J-223JE	1	435032234R1
PCB U001	R5651	C-CARBON R	RN72K1J-122JE	1	435031224R1
PCB U001	R5652	C-CARBON R	RN72K1J-122JE	1	435031224R1
PCB U001	R5653	C-CARBON R	RN72K1J-101JE	1	435031014R1
PCB U001	R5654	C-CARBON R	RN72K1J-101JE	1	435031014R1
PCB U001	R5655	C-CARBON R	RN72K1J-224JE	1	435032244R1
PCB U001	R5656	C-CARBON R	RN72K1J-224JE	1	435032244R1
PCB U001	R5657	C-CARBON R	RN72K1J-224JE	1	435032244R1
PCB U001	R5660	METAL R	RNU1WCJ-1.5	1	453630154T
PCB U001	R5661	METAL R	RNU1WCJ-1.5	1	453630154T
PCB U001	R5663	CEMENT R	RSS5WJ-15(BGR5NJ)	1	4800082
PCB U001	R5664	CEMENT R	RSS5WJ-15(BGR5NJ)	1	4800082
PCB U001	R5666	CARBON R	R16J-22	1	417342204T
PCB U001	R5667	CARBON R	R16J-22	1	417342204T
PCB U001	R5669	C-CARBON R	RN72K1J-224JE	1	435032244R1
PCB U001	R5672	C-CARBON R	RN72K1J-100JE	1	435031004R1
PCB U001	R5673	C-CARBON R	RN72K1J-100JE	1	435031004R1
PCB U001	R5674	METAL O R	RS1WBJ-470	1	443624714T
PCB U001	R5675	METAL O R	RS1WBJ-22	1	443622204T
PCB U001	R5676	METAL O R	RS1WBJ-22	1	443622204T
PCB U001	R5677	METAL O R	RS1WBJ-22	1	443622204T
PCB U001	R5678	METAL O R	RS1WBJ-22	1	443622204T
PCB U001	R5679	CARBON R	R16J-1.2K	1	417341224T
PCB U001	R5681	C-CARBON R	RN72K1J-224JE	1	435032244R1
PCB U001	R5682	C-CARBON R	RN72K1J-224JE	1	435032244R1
PCB U001	R5683	C-CARBON R	RN72K1J-224JE	1	435032244R1
PCB U001	R5684	C-CARBON R	RN72K1J-224JE	1	435032244R1
PCB U001	R5685	CARBON R	R16J-1.2K	1	417341224T
PCB U001	R5692	C-CARBON R	RN72K1J-104JE	1	435031044R1
PCB U001	R5693	C-CARBON R	RN72K1J-472JE	1	435034724R1
PCB U001	R5694	C-CARBON R	RN72K1J-472JE	1	435034724R1
PCB U001	R5695	C-CARBON R	RN72K1J-224JE	1	435032244R1
PCB U001	R5696	C-CARBON R	RN72K1J-224JE	1	435032244R1
PCB U001	R5711	C-CARBON R	RN72K1J-224JE	1	435032244R1
PCB U001	R5712	C-CARBON R	RN72K1J-224JE	1	435032244R1
PCB U001	R5714	C-CARBON R	RN72K1J-224JE	1	435032244R1
PCB U001	R5715	C-CARBON R	RN72K1J-224JE	1	435032244R1
PCB U001	R5716	C-CARBON R	RN72K1J-224JE	1	435032244R1
PCB U001	R5732	C-CARBON R	RN72K1J-224JE	1	435032244R1

PCB U001	R5733	C-CARBON R	RN72K1J-224JE	1	435032244R1
PCB U001	R5734	C-CARBON R	RN72K1J-391JE	1	435033914R1
PCB U001	R5735	C-CARBON R	RN72K1J-391JE	1	435033914R1
PCB U001	R5738	C-CARBON R	RN72K1J-224JE	1	435032244R1
PCB U001	R5739	C-CARBON R	RN72K1J-224JE	1	435032244R1
PCB U001	R5740	C-CARBON R	RN72K1J-391JE	1	435033914R1
PCB U001	R5741	C-CARBON R	RN72K1J-391JE	1	435033914R1
PCB U001	R5744	C-CARBON R	RN72K1J-224JE	1	435032244R1
PCB U001	R5745	C-CARBON R	RN72K1J-224JE	1	435032244R1
PCB U001	R5746	C-CARBON R	RN72K1J-391JE	1	435033914R1
PCB U001	R5747	C-CARBON R	RN72K1J-391JE	1	435033914R1
PCB U001	R5750	C-CARBON R	RN72K1J-102JE	1	435031024R1
PCB U001	R5751	C-CARBON R	RN72K1J-102JE	1	435031024R1
PCB U001	R5752	C-CARBON R	RN72K1J-101JE	1	435031014R1
PCB U001	R5753	C-CARBON R	RN72K1J-101JE	1	435031014R1
PCB U001	R5754	C-CARBON R	RN72K1J-224JE	1	435032244R1
PCB U001	R5755	C-CARBON R	RN72K1J-224JE	1	435032244R1
PCB U001	R5756	C-CARBON R	RN72K1J-101JE	1	435031014R1
PCB U001	R5757	C-CARBON R	RN72K1J-101JE	1	435031014R1
PCB U001	R5782	C-CARBON R	RN72K1J-224JE	1	435032244R1
PCB U001	R5783	C-CARBON R	RN72K1J-224JE	1	435032244R1
PCB U001	R5788	C-CARBON R	RN72K1J-472JE	1	435034724R1
PCB U001	R5789	C-CARBON R	RN72K1J-103JE	1	435031034R1
PCB U001	R5790	C-CARBON R	RN72K1J-123JE	1	435031234R1
PCB U001	R5791	C-CARBON R	RN72K1J-223JE	1	435032234R1
PCB U001	R5792	C-CARBON R	RN72K1J-103JE	1	435031034R1
PCB U001	R5793	C-CARBON R	RN72K1J-333JE	1	435033334R1
PCB U001	R5794	C-CARBON R	RN72K1J-333JE	1	435033334R1
PCB U001	R5795	C-CARBON R	RN72K1J-333JE	1	435033334R1
PCB U001	R5796	C-CARBON R	RN72K1J-682JE	1	435036824R1
PCB U001	R5797	C-CARBON R	RN72K1J-104JE	1	435031044R1
PCB U001	R5798	CARBON R	R16J-12K	1	417341234T
PCB U001	R5800	C-CARBON R	RN72K1J-102JE	1	435031024R1
PCB U001	R5801	C-CARBON R	RN72K1J-102JE	1	435031024R1
PCB U001	R5813	C-CARBON R	RN72K1J-000JE	1	435030004R1
PCB U001	R5815	C-CARBON R	RN72K1J-000JE	1	435030004R1
PCB U001	R5816	C-CARBON R	RN72K1J-000JE	1	435030004R1
PCB U001	R5817	C-CARBON R	RN72K1J-000JE	1	435030004R1
PCB U001	R5818	C-CARBON R	RN72K1J-000JE	1	435030004R1
PCB U001	R5819	C-CARBON R	RN72K1J-000JE	1	435030004R1
PCB U001	R5820	C-CARBON R	RN72K1J-000JE	1	435030004R1



PCB U001	R5865	C-CARBON R	RN72K1J-000JE	1	435030004R1
PCB U001	R5866	C-CARBON R	RN72K1J-000JE	1	435030004R1
PCB U001	R5867	C-CARBON R	RN72K1J-000JE	1	435030004R1
PCB U001	R5868	C-CARBON R	RN72K1J-000JE	1	435030004R1
PCB U001	R5871	C-CARBON R	RN72K1J-000JE	1	435030004R1
PCB U001	R5872	C-CARBON R	RN72K1J-000JE	1	435030004R1
PCB U001	R5873	C-CARBON R	RN72K1J-000JE	1	435030004R1
PCB U001	R5874	C-CARBON R	RN72K1J-000JE	1	435030004R1
PCB U001	R5875	C-CARBON R	RN72K1J-000JE	1	435030004R1
PCB U001	R5876	C-CARBON R	RN72K1J-000JE	1	435030004R1
PCB U001	R5877	C-CARBON R	RN72K1J-000JE	1	435030004R1
PCB U001	R5878	C-CARBON R	RN72K1J-000JE	1	435030004R1
PCB U001	R5879	C-CARBON R	RN72K1J-000JE	1	435030004R1
PCB U001	R5880	C-CARBON R	RN72K1J-000JE	1	435030004R1
PCB U001	R5881	C-CARBON R	RN72K1J-000JE	1	435030004R1
PCB U001	R5883	C-CARBON R	RN72K1J-000JE	1	435030004R1
PCB U001	R5884	C-CARBON R	RN72K1J-000JE	1	435030004R1
PCB U001	R5885	C-CARBON R	RN72K1J-000JE	1	435030004R1
PCB U001	R5886	C-CARBON R	RN72K1J-000JE	1	435030004R1
PCB U001	R5887	C-CARBON R	RN72K1J-000JE	1	435030004R1
PCB U001	R5889	C-CARBON R	RN72K1J-000JE	1	435030004R1
PCB U001	R5890	C-CARBON R	RN72K1J-000JE	1	435030004R1
PCB U001	R5892	C-CARBON R	RN72K1J-000JE	1	435030004R1
PCB U001	R5893	C-CARBON R	RN72K1J-000JE	1	435030004R1
PCB U001	R5902	C-CARBON R	RN72K1J-000JE	1	435030004R1
PCB U001	R5904	C-CARBON R	RN72K1J-000JE	1	435030004R1
PCB U001	R5905	C-CARBON R	RN72K1J-000JE	1	435030004R1
PCB U001	R5906	C-CARBON R	RN72K1J-000JE	1	435030004R1
PCB U001	R5907	C-CARBON R	RN72K1J-000JE	1	435030004R1
PCB U001	R5908	C-CARBON R	RN72K1J-000JE	1	435030004R1
PCB U001	R5909	C-CARBON R	RN72K1J-224JE	1	435032244R1
PCB U001	R5910	C-CARBON R	RN72K1J-224JE	1	435032244R1
PCB U001	R5911	C-CARBON R	RN72K1J-102JE	1	435031024R1
PCB U001	R5912	C-CARBON R	RN72K1J-102JE	1	435031024R1
PCB U001	R5913	C-CARBON R	RN72K1J-101JE	1	435031014R1
PCB U001	R5914	C-CARBON R	RN72K1J-101JE	1	435031014R1
PCB U001	R5915	C-CARBON R	RN72K1J-224JE	1	435032244R1
PCB U001	R5916	C-CARBON R	RN72K1J-224JE	1	435032244R1
PCB U001	R5917	C-CARBON R	RN72K1J-101JE	1	435031014R1
PCB U001	R5918	C-CARBON R	RN72K1J-101JE	1	435031014R1
PCB U001	R5921	C-CARBON R	RN72K1J-000JE	1	435030004R1

PCB U001	R5922	C-CARBON R	RN72K1J-000JE	1	435030004R1
PCB U001	R5923	C-CARBON R	RN72K1J-000JE	1	435030004R1
PCB U001	R5924	C-CARBON R	RN72K1J-000JE	1	435030004R1
PCB U001	R5925	C-CARBON R	RN72K1J-000JE	1	435030004R1
PCB U001	R5928	C-CARBON R	RN72K1J-000JE	1	435030004R1
PCB U001	R5929	C-CARBON R	RN72K1J-000JE	1	435030004R1
PCB U001	R5930	C-CARBON R	RN72K1J-000JE	1	435030004R1
PCB U001	R5931	C-CARBON R	RN72K1J-000JE	1	435030004R1
PCB U001	R5932	C-CARBON R	RN72K1J-000JE	1	435030004R1
PCB U001	R5933	C-CARBON R	RN72K1J-000JE	1	435030004R1
PCB U001	R5934	C-CARBON R	RN72K1J-000JE	1	435030004R1
PCB U001	R5935	C-CARBON R	RN72K1J-000JE	1	435030004R1
PCB U001	R5936	C-CARBON R	RN72K1J-000JE	1	435030004R1
PCB U001	R5937	C-CARBON R	RN72K1J-000JE	1	435030004R1
PCB U001	R5938	C-CARBON R	RN72K1J-000JE	1	435030004R1
PCB U001	R5939	C-CARBON R	RN72K1J-000JE	1	435030004R1
PCB U001	R5940	C-CARBON R	RN72K1J-000JE	1	435030004R1
PCB U001	R5941	C-CARBON R	RN72K1J-000JE	1	435030004R1
PCB U001	R5942	C-CARBON R	RN72K1J-000JE	1	435030004R1
PCB U001	R5943	C-CARBON R	RN72K1J-000JE	1	435030004R1
PCB U001	R6000	CARBON R	R16J-4.7K	1	417344724T
PCB U001	R6001	CARBON R	R16J-4.7K	1	417344724T
PCB U001	R6002	CARBON R	R16J-4.7K	1	417344724T
PCB U001	R6003	CARBON R	R16J-4.7K	1	417344724T
PCB U001	R6004	CARBON R	R16J-4.7K	1	417344724T
PCB U001	R6005	CARBON R	R16J-4.7K	1	417344724T
PCB U001	R6006	CARBON R	R16J-4.7K	1	417344724T
PCB U001	R6010	CARBON R	R16J-3.3K	1	417343324T
PCB U001	R6011	CARBON R	R16J-3.3K	1	417343324T
PCB U001	R6012	CARBON R	R16J-3.3K	1	417343324T
PCB U001	R6013	CARBON R	R16J-3.3K	1	417343324T
PCB U001	R6014	CARBON R	R16J-3.3K	1	417343324T
PCB U001	R6015	CARBON R	R16J-3.3K	1	417343324T
PCB U001	R6016	CARBON R	R16J-3.3K	1	417343324T
PCB U001	R6030	CARBON R	R16J-2.2K	1	417342224T
PCB U001	R6031	CARBON R	R16J-2.2K	1	417342224T
PCB U001	R6032	CARBON R	R16J-2.2K	1	417342224T
PCB U001	R6033	CARBON R	R16J-2.2K	1	417342224T
PCB U001	R6034	CARBON R	R16J-2.2K	1	417342224T
PCB U001	R6035	CARBON R	R16J-2.2K	1	417342224T
PCB U001	R6036	CARBON R	R16J-2.2K	1	417342224T

PCB U001	R6040	TRIM R	N06HR2KBC	1	5210390T
PCB U001	R6041	TRIM R	N06HR2KBC	1	5210390T
PCB U001	R6042	TRIM R	N06HR2KBC	1	5210390T
PCB U001	R6043	TRIM R	N06HR2KBC	1	5210390T
PCB U001	R6044	TRIM R	N06HR2KBC	1	5210390T
PCB U001	R6045	TRIM R	N06HR2KBC	1	5210390T
PCB U001	R6046	TRIM R	N06HR2KBC	1	5210390T
PCB U001	R6050	CARBON R	R16J-2.7K	1	417342724T
PCB U001	R6051	CARBON R	R16J-2.7K	1	417342724T
PCB U001	R6052	CARBON R	R16J-2.7K	1	417342724T
PCB U001	R6053	CARBON R	R16J-2.7K	1	417342724T
PCB U001	R6054	CARBON R	R16J-2.7K	1	417342724T
PCB U001	R6055	CARBON R	R16J-2.7K	1	417342724T
PCB U001	R6056	CARBON R	R16J-2.7K	1	417342724T
PCB U001	R6070	NF CARBON R	R25J-82	1	415478204T
PCB U001	R6071	NF CARBON R	R25J-82	1	415478204T
PCB U001	R6072	NF CARBON R	R25J-82	1	415478204T
PCB U001	R6073	NF CARBON R	R25J-82	1	415478204T
PCB U001	R6074	NF CARBON R	R25J-82	1	415478204T
PCB U001	R6075	NF CARBON R	R25J-82	1	415478204T
PCB U001	R6076	NF CARBON R	R25J-82	1	415478204T
PCB U001	R6080	CARBON R	R16J-10	1	417341004T
PCB U001	R6081	CARBON R	R16J-10	1	417341004T
PCB U001	R6082	CARBON R	R16J-10	1	417341004T
PCB U001	R6083	CARBON R	R16J-10	1	417341004T
PCB U001	R6084	CARBON R	R16J-10	1	417341004T
PCB U001	R6085	CARBON R	R16J-10	1	417341004T
PCB U001	R6086	CARBON R	R16J-10	1	417341004T
PCB U001	R6090	CARBON R	R16J-10	1	417341004T
PCB U001	R6091	CARBON R	R16J-10	1	417341004T
PCB U001	R6092	CARBON R	R16J-10	1	417341004T
PCB U001	R6093	CARBON R	R16J-10	1	417341004T
PCB U001	R6094	CARBON R	R16J-10	1	417341004T
PCB U001	R6095	CARBON R	R16J-10	1	417341004T
PCB U001	R6096	CARBON R	R16J-10	1	417341004T
PCB U001	R6100	METAL PR	MPR5W+5W 0R22	1	4000233
PCB U001	R6100 or	METAL PR	RGC55 0.22	(1)	4000132
PCB U001	R6101	METAL PR	MPR5W+5W 0R22	1	4000233
PCB U001	R6101 or	METAL PR	RGC55 0.22	(1)	4000132
PCB U001	R6102	METAL PR	MPR5W+5W 0R22	1	4000233
PCB U001	R6102 or	METAL PR	RGC55 0.22	(1)	4000132

PCB U001	R6103	METAL PR	MPR5W+5W 0R22	1	4000233
PCB U001	R6103 or	METAL PR	RGC55 0.22	(1)	4000132
PCB U001	R6104	METAL PR	MPR5W+5W 0R22	1	4000233
PCB U001	R6104 or	METAL PR	RGC55 0.22	(1)	4000132
PCB U001	R6105	METAL PR	MPR5W+5W 0R22	1	4000233
PCB U001	R6105 or	METAL PR	RGC55 0.22	(1)	4000132
PCB U001	R6106	METAL PR	MPR5W+5W 0R22	1	4000233
PCB U001	R6106 or	METAL PR	RGC55 0.22	(1)	4000132
PCB U001	R6140	C-CARBON R	RN72K1J-563JE	1	435035634R1
PCB U001	R6141	C-CARBON R	RN72K1J-563JE	1	435035634R1
PCB U001	R6142	C-CARBON R	RN72K1J-563JE	1	435035634R1
PCB U001	R6143	C-CARBON R	RN72K1J-563JE	1	435035634R1
PCB U001	R6144	C-CARBON R	RN72K1J-563JE	1	435035634R1
PCB U001	R6145	C-CARBON R	RN72K1J-563JE	1	435035634R1
PCB U001	R6146	C-CARBON R	RN72K1J-563JE	1	435035634R1
PCB U001	R6150	C-CARBON R	RN72K1J-103JE	1	435031034R1
PCB U001	R6151	C-CARBON R	RN72K1J-103JE	1	435031034R1
PCB U001	R6152	C-CARBON R	RN72K1J-103JE	1	435031034R1
PCB U001	R6153	C-CARBON R	RN72K1J-103JE	1	435031034R1
PCB U001	R6154	C-CARBON R	RN72K1J-103JE	1	435031034R1
PCB U001	R6155	C-CARBON R	RN72K1J-103JE	1	435031034R1
PCB U001	R6156	C-CARBON R	RN72K1J-103JE	1	435031034R1
PCB U001	R6160	CARBON R	R16J-33K	1	417343334T
PCB U001	R6161	CARBON R	R16J-33K	1	417343334T
PCB U001	R6162	CARBON R	R16J-33K	1	417343334T
PCB U001	R6163	CARBON R	R16J-33K	1	417343334T
PCB U001	R6164	CARBON R	R16J-33K	1	417343334T
PCB U001	R6165	CARBON R	R16J-33K	1	417343334T
PCB U001	R6166	CARBON R	R16J-33K	1	417343334T
PCB U001	R6170	CARBON R	R16J-47K	1	417344734T
PCB U001	R6171	CARBON R	R16J-47K	1	417344734T
PCB U001	R6172	CARBON R	R16J-47K	1	417344734T
PCB U001	R6173	CARBON R	R16J-47K	1	417344734T
PCB U001	R6174	CARBON R	R16J-47K	1	417344734T
PCB U001	R6175	CARBON R	R16J-47K	1	417344734T
PCB U001	R6176	CARBON R	R16J-47K	1	417344734T
PCB U001	R6180	CARBON R	R16J-47K	1	417344734T
PCB U001	R6181	CARBON R	R16J-47K	1	417344734T
PCB U001	R6182	CARBON R	R16J-47K	1	417344734T
PCB U001	R6183	CARBON R	R16J-47K	1	417344734T
PCB U001	R6184	CARBON R	R16J-47K	1	417344734T



PCB U001	R6185	CARBON R	R16J-47K	1	417344734T
PCB U001	R6186	CARBON R	R16J-47K	1	417344734T
PCB U001	R6197	METAL O R	RS1/2WBJ-33	1	443523304T
PCB U001	R6250	NF CARBON R	R25J-120	1	415471214T
PCB U001	R6251	NF CARBON R	R25J-120	1	415471214T
PCB U001	R6252	NF CARBON R	R25J-120	1	415471214T
PCB U001	R6253	NF CARBON R	R25J-120	1	415471214T
PCB U001	R6254	NF CARBON R	R25J-120	1	415471214T
PCB U001	R6255	NF CARBON R	R25J-120	1	415471214T
PCB U001	R6256	NF CARBON R	R25J-120	1	415471214T
PCB U001	R6260	NF CARBON R	R25J-120	1	415471214T
PCB U001	R6261	NF CARBON R	R25J-120	1	415471214T
PCB U001	R6262	NF CARBON R	R25J-120	1	415471214T
PCB U001	R6263	NF CARBON R	R25J-120	1	415471214T
PCB U001	R6264	NF CARBON R	R25J-120	1	415471214T
PCB U001	R6265	NF CARBON R	R25J-120	1	415471214T
PCB U001	R6266	NF CARBON R	R25J-120	1	415471214T
PCB U001	R6270	NF CARBON R	R25J-18	1	415471804T
PCB U001	R6271	NF CARBON R	R25J-18	1	415471804T
PCB U001	R6272	NF CARBON R	R25J-18	1	415471804T
PCB U001	R6273	NF CARBON R	R25J-18	1	415471804T
PCB U001	R6274	NF CARBON R	R25J-18	1	415471804T
PCB U001	R6275	NF CARBON R	R25J-18	1	415471804T
PCB U001	R6276	NF CARBON R	R25J-18	1	415471804T
PCB U001	R6280	NF CARBON R	R25J-18	1	415471804T
PCB U001	R6281	NF CARBON R	R25J-18	1	415471804T
PCB U001	R6282	NF CARBON R	R25J-18	1	415471804T
PCB U001	R6283	NF CARBON R	R25J-18	1	415471804T
PCB U001	R6284	NF CARBON R	R25J-18	1	415471804T
PCB U001	R6285	NF CARBON R	R25J-18	1	415471804T
PCB U001	R6286	NF CARBON R	R25J-18	1	415471804T
PCB U001	R6290	NF CARBON R	R25J-2.2	1	415470224T
PCB U001	R6291	NF CARBON R	R25J-2.2	1	415470224T
PCB U001	R6292	NF CARBON R	R25J-2.2	1	415470224T
PCB U001	R6293	NF CARBON R	R25J-2.2	1	415470224T
PCB U001	R6294	NF CARBON R	R25J-2.2	1	415470224T
PCB U001	R6295	NF CARBON R	R25J-2.2	1	415470224T
PCB U001	R6296	NF CARBON R	R25J-2.2	1	415470224T
PCB U001	R6300	NF CARBON R	R25J-2.2	1	415470224T
PCB U001	R6301	NF CARBON R	R25J-2.2	1	415470224T
PCB U001	R6302	NF CARBON R	R25J-2.2	1	415470224T

PCB U001	R6303	NF CARBON R	R25J-2.2	1	415470224T	
PCB U001	R6304	NF CARBON R	R25J-2.2	1	415470224T	
PCB U001	R6305	NF CARBON R	R25J-2.2	1	415470224T	
PCB U001	R6306	NF CARBON R	R25J-2.2	1	415470224T	
PCB U001	R6310	NF CARBON R	R25J-10	1	415471004T	
PCB U001	R6311	NF CARBON R	R25J-10	1	415471004T	
PCB U001	R6312	NF CARBON R	R25J-10	1	415471004T	
PCB U001	R6313	NF CARBON R	R25J-10	1	415471004T	
PCB U001	R6314	NF CARBON R	R25J-10	1	415471004T	
PCB U001	R6315	NF CARBON R	R25J-10	1	415471004T	
PCB U001	R6316	NF CARBON R	R25J-10	1	415471004T	
PCB U001	R6701	C-CARBON R	RN72K1J-223JE	1	435032234R1	
PCB U001	R6702	C-CARBON R	RN72K1J-103JE	1	435031034R1	
PCB U001	R6704	C-CARBON R	RN72K1J-473JE	1	435034734R1	
PCB U001	R6706	C-CARBON R	RN72K1J-224JE	1	435032244R1	
PCB U001	R6708	C-CARBON R	RN72K1J-333JE	1	435033334R1	
PCB U001	R6709	C-CARBON R	RN72K1J-392JE	1	435033924R1	
PCB U001	R6710	C-CARBON R	RN72K1J-123JE	1	435031234R1	
PCB U001	R6712	C-CARBON R	RN72K1J-103JE	1	435031034R1	
PCB U001	R6714	C-CARBON R	RN72K1J-333JE	1	435033334R1	
PCB U001	R6716	C-CARBON R	RN72K1J-563JE	1	435035634R1	
PCB U001	R6902	C-CARBON R	RN72K1J-102JE	1	435031024R1	
PCB U001	R6903	C-CARBON R	RN72K1J-473JE	1	435034734R1	
PCB U001	R6907	C-CARBON R	RN72K1J-000JE	1	435030004R1	
PCB U001	[SW TRM]					
PCB U001	E5507A	TRM	NTM-1P232(M1700)	1	25060301	
PCB U001	E5509A	TRM	NTM-1P232(M1700)	1	25060301	
PCB U001	E5519	TRM-423(SCREW)	NEJITANSI ST3	1	25060495	
PCB U001	E5520	TRM-423(SCREW)	NEJITANSI ST3	1	25060495	
PCB U001	F6901A	FUSE HOLDER	SN5051	1	250113	!
PCB U001	F6901B	FUSE HOLDER	SN5051	1	250113	!
PCB U001	F6902A	FUSE HOLDER	SN5051	1	250113	!
PCB U001	F6902B	FUSE HOLDER	SN5051	1	250113	!
PCB U001	JL104A	WIRE HOL	NSCT-9P880	1	25051093	
PCB U001	JL4500A	WIRE HOL	NSCT-3P874	1	25051087	
PCB U001	JL5513A	WIRE HOL	NSCT-5P876	1	25051089	
PCB U001	JL5514A	WIRE HOL	NSCT-7P898	1	25051111	
PCB U001	JL5514B	SOCKET	NSCT-7P99	1	25050271	
PCB U001	JL5515B	WIRE TRAP	NPLG-11P594	1	25055632	
PCB U001	JL6402A	WIRE HOL	NSCT-3P874	1	25051087	
PCB U001	JL6402B	WIRE HOL	NSCT-3P874	1	25051087	

PCB U001	JL6600A	WIRE HOL	NSCT-7P898	1	25051111	
PCB U001	JL6603A	WIRE HOL	NSCT-9P900	1	25051113	
PCB U001	JL6606B	WIRE TRAP	NPLG-7P590	1	25055628	
PCB U001	JL6620A	WIRE HOL	NSCT-7P878	1	25051091	
PCB U001	P001	PWB	BCAMP-0072	1	25140072B	N
PCB U001	P002	PWB	BCASP-0073	{ 1 }	25140073	N
PCB U001	P003	PWB	BCETC-0074	{ 1 }	25140074	N
PCB U001	P004	PWB	BCETC-0075	{ 1 }	25140075	
PCB U001	P006	PWB	BCETC-0089	{ 1 }	25140089	
PCB U001	P4500	PLUG	NPLG-2P83	1	25055099	
PCB U001	P4600	ST JACK	HSJ1002-01-6020	1	25045647	
PCB U001	P4601	ST JACK	HSJ1002-01-6020	1	25045647	
PCB U001	P4602	ST JACK	HSJ1002-01-6020	1	25045647	
PCB U001	P5500	PIN JACK	NPJ-2PDWR583	1	25045803	
PCB U001	P5501	PIN JACK	NPJ-6PDRW665	1	25045894	
PCB U001	P5502	PIN JACK	NPJ-6PDRW665	1	25045894	
PCB U001	P5503	PIN JACK	NPJ-6PDRW665	1	25045894	
PCB U001	P5504	PIN JACK	NPJ-1PDG700	1	25045934	
PCB U001	P5505	PIN JACK	NPJ-6PDLENTP702	1	25045936	
PCB U001	P5506	PIN JACK	NPJ-4PDRW592	1	25045812	
PCB U001	P5509	CRIMP AS	CRIMP AS	1	2069925170UL	
PCB U001	P5510A	SOCKET AS	NSAS-26P1742	1	2009991118UL	
PCB U001	P5510B	PLUG	NPLG-13P360	1	25055377	
PCB U001	P5510C	CRIMP AS	CRIMP SR805_2	1	20799170UL	
PCB U001	P5510D	CRIMP AS	CRIMP SR805_1	1	20799169UL	
PCB U001	P5512	SOCKET	NSCT-15P2195	1	25052298	
PCB U001	P5513	SOCKET	NSCT-19P2199	1	25052302	
PCB U001	P5516	HOLDER	HOLDER(CLAMP)	1	27190540-1	
PCB U001	P5518	SOCKET	NSCT-3P2183	1	25052286	
PCB U001	P6000B	PLUG	NPLG-7P0962	1	25056012	
PCB U001	P6001B	PLUG	NPLG-7P0962	1	25056012	
PCB U001	P6002B	PLUG	NPLG-7P0962	1	25056012	
PCB U001	P6003B	PLUG	NPLG-7P0962	1	25056012	
PCB U001	P6004B	PLUG	NPLG-7P0962	1	25056012	
PCB U001	P6005B	PLUG	NPLG-7P0962	1	25056012	
PCB U001	P6006B	PLUG	NPLG-7P0962	1	25056012	
PCB U001	P6011A	RETAINER	(BUS-D)	1	27142115A	
PCB U001	P6020	HOLDER	HOLDER(CLAMP)	1	27190540-1	
PCB U001	P6080	PLUG	NPLG-2P130	1	25055146	
PCB U001	P6081	PLUG	NPLG-2P130	1	25055146	
PCB U001	P6082	PLUG	NPLG-2P130	1	25055146	

PCB U001	P6083	PLUG	NPLG-2P130	1	25055146	
PCB U001	P6084	PLUG	NPLG-2P130	1	25055146	
PCB U001	P6085	PLUG	NPLG-2P130	1	25055146	
PCB U001	P6086	PLUG	NPLG-2P130	1	25055146	
PCB U001	P6900	CRIMP AS	CRIMP AS	1	2069925170UL	
PCB U001	P6901	CRIMP AS	CRIMP AS	1	2069925142UL	
PCB U001	P6902	CRIMP AS	CRIMP AS	1	2069925208UL	
PCB U001	P6950	PLUG	NPLG-5P152	1	25055168	
PCB U001	P907	AC INLET	NPLG-2P913	1	25055960	!
PCB U001	P921	SOCKET AS	NSAS-2P1796	1	2009991162UL	!
PCB U001	RL6901	RELAY	NRL-1P10A-DC12-140	1	25065584	!
PCB U001	RL6902	RELAY	NRL-1P10A-DC12-140	1	25065584	!
PCB U002	<b>U0020</b>	SPEAKER TERMINAL-1 PC BOARD (BATRM-0083-1G/ 1H)				
PCB U002	<b>U0021</b>	PRIMARY POWER SUPPLY PC BOARD (BAPS-0084-1G/ 1H)				
PCB U002	<b>U0022</b>	SPEAKER TERMINAL-2 PC BOARD (BATRM-0085-1G/ 1H)				
PCB U002	<b>U0023</b>	CENTER SPEAKER TERMINAL PC BOARD (BATRM-0086-1G/ 1H)				
PCB U002	<b>U0024</b>	POWER AMP. INPUT CIRCUIT PC BOARD (BACLA-0087-1G/ 1H)				
PCB U002						
PCB U002	<b>CIRCUIT. NO.</b>	<b>PART NAME</b>	<b>DESCRIPTION</b>	<b>Q'TY</b>	<b>PART NO. (SN)</b>	<b>REMARKS</b>
PCB U002	<b>[SEMI CONDUCTOR]</b>					
PCB U002	D5000	ZENER D	MTZJ5.6B	1	224470562T	
PCB U002	D5001	ZENER D	MTZJ5.6B	1	224470562T	
PCB U002	D5002	ZENER D	MTZJ5.6B	1	224470562T	
PCB U002	D5003	ZENER D	MTZJ5.6B	1	224470562T	
PCB U002	D5004	ZENER D	MTZJ5.6B	1	224470562T	
PCB U002	D5005	ZENER D	MTZJ5.6B	1	224470562T	
PCB U002	D5006	ZENER D	MTZJ5.6B	1	224470562T	
PCB U002	D6600	DIODE	1SS133	1	223163T	
PCB U002	D6603	DIODE	1SS133	1	223163T	
PCB U002	D6605	DIODE	1SS133	1	223163T	
PCB U002	D6607	DIODE	1SS133	1	223163T	
PCB U002	D6609	DIODE	1SS133	1	223163T	
PCB U002	D6610	DIODE	1SS133	1	223163T	
PCB U002	D911	DIODE	1SS133	1	223163T	
PCB U002	D912	DIODE	1SS133	1	223163T	
PCB U002	D921	DIODE	1SS133	1	223163T	
PCB U002	D922	DIODE	1SS133	1	223163T	
PCB U002	D923	DIODE	1SS133	1	223163T	
PCB U002	D924	DIODE	1SS133	1	223163T	
PCB U002	D925	DIODE	1SS133	1	223163T	

PCB U002	D930	DIODE	1SS133	1	223163T
PCB U002	D931	DIODE	1SS133	1	223163T
PCB U002	D933	DIODE	1SS133	1	223163T
PCB U002	D934	ZENER D	MTZJ3.6B	1	224470362T
PCB U002	D935	DIODE	1SS133	1	223163T
PCB U002	Q5000	TR	2SC2240-BL(TPE2_F)	1	2211406T
PCB U002	Q5001	TR	2SC2240-BL(TPE2_F)	1	2211406T
PCB U002	Q5002	TR	2SC2240-BL(TPE2_F)	1	2211406T
PCB U002	Q5003	TR	2SC2240-BL(TPE2_F)	1	2211406T
PCB U002	Q5004	TR	2SC2240-BL(TPE2_F)	1	2211406T
PCB U002	Q5005	TR	2SC2240-BL(TPE2_F)	1	2211406T
PCB U002	Q5006	TR	2SC2240-BL(TPE2_F)	1	2211406T
PCB U002	Q5010	TR	2SC2240-BL(TPE2_F)	1	2211406T
PCB U002	Q5011	TR	2SC2240-BL(TPE2_F)	1	2211406T
PCB U002	Q5012	TR	2SC2240-BL(TPE2_F)	1	2211406T
PCB U002	Q5013	TR	2SC2240-BL(TPE2_F)	1	2211406T
PCB U002	Q5014	TR	2SC2240-BL(TPE2_F)	1	2211406T
PCB U002	Q5015	TR	2SC2240-BL(TPE2_F)	1	2211406T
PCB U002	Q5016	TR	2SC2240-BL(TPE2_F)	1	2211406T
PCB U002	Q5030	TR	2SA949-Y(TPE6_F)	1	2211354T
PCB U002	Q5031	TR	2SA949-Y(TPE6_F)	1	2211354T
PCB U002	Q5032	TR	2SA949-Y(TPE6_F)	1	2211354T
PCB U002	Q5033	TR	2SA949-Y(TPE6_F)	1	2211354T
PCB U002	Q5034	TR	2SA949-Y(TPE6_F)	1	2211354T
PCB U002	Q5035	TR	2SA949-Y(TPE6_F)	1	2211354T
PCB U002	Q5036	TR	2SA949-Y(TPE6_F)	1	2211354T
PCB U002	Q5040	TR	2SA949-Y(TPE6_F)	1	2211354T
PCB U002	Q5041	TR	2SA949-Y(TPE6_F)	1	2211354T
PCB U002	Q5042	TR	2SA949-Y(TPE6_F)	1	2211354T
PCB U002	Q5043	TR	2SA949-Y(TPE6_F)	1	2211354T
PCB U002	Q5044	TR	2SA949-Y(TPE6_F)	1	2211354T
PCB U002	Q5045	TR	2SA949-Y(TPE6_F)	1	2211354T
PCB U002	Q5046	TR	2SA949-Y(TPE6_F)	1	2211354T
PCB U002	Q5050	TR	2SC2240-BL(TPE2_F)	1	2211406T
PCB U002	Q5050 or	TR	2SC2240-GR	(1)	2211405T
PCB U002	Q5051	TR	2SC2240-BL(TPE2_F)	1	2211406T
PCB U002	Q5051 or	TR	2SC2240-GR	(1)	2211405T
PCB U002	Q5052	TR	2SC2240-BL(TPE2_F)	1	2211406T
PCB U002	Q5052 or	TR	2SC2240-GR	(1)	2211405T
PCB U002	Q5053	TR	2SC2240-BL(TPE2_F)	1	2211406T
PCB U002	Q5053 or	TR	2SC2240-GR	(1)	2211405T

PCB U002	Q5054	TR	2SC2240-BL(TPE2_F)	1	2211406T
PCB U002	Q5054 or	TR	2SC2240-GR	(1)	2211405T
PCB U002	Q5055	TR	2SC2240-BL(TPE2_F)	1	2211406T
PCB U002	Q5055 or	TR	2SC2240-GR	(1)	2211405T
PCB U002	Q5056	TR	2SC2240-BL(TPE2_F)	1	2211406T
PCB U002	Q5056 or	TR	2SC2240-GR	(1)	2211405T
PCB U002	Q5060	TR	2SA1360-Y	1	2202094
PCB U002	Q5060 or	TR	2SA1360-O	(1)	2202093
PCB U002	Q5061	TR	2SA1360-Y	1	2202094
PCB U002	Q5061 or	TR	2SA1360-O	(1)	2202093
PCB U002	Q5062	TR	2SA1360-Y	1	2202094
PCB U002	Q5062 or	TR	2SA1360-O	(1)	2202093
PCB U002	Q5063	TR	2SA1360-Y	1	2202094
PCB U002	Q5063 or	TR	2SA1360-O	(1)	2202093
PCB U002	Q5064	TR	2SA1360-Y	1	2202094
PCB U002	Q5064 or	TR	2SA1360-O	(1)	2202093
PCB U002	Q5065	TR	2SA1360-Y	1	2202094
PCB U002	Q5065 or	TR	2SA1360-O	(1)	2202093
PCB U002	Q5066	TR	2SA1360-Y	1	2202094
PCB U002	Q5066 or	TR	2SA1360-O	(1)	2202093
PCB U002	Q5070	TR	2SC3423-Y	1	2202104
PCB U002	Q5070 or	TR	2SC3423-O	(1)	2202103
PCB U002	Q5071	TR	2SC3423-Y	1	2202104
PCB U002	Q5071 or	TR	2SC3423-O	(1)	2202103
PCB U002	Q5072	TR	2SC3423-Y	1	2202104
PCB U002	Q5072 or	TR	2SC3423-O	(1)	2202103
PCB U002	Q5073	TR	2SC3423-Y	1	2202104
PCB U002	Q5073 or	TR	2SC3423-O	(1)	2202103
PCB U002	Q5074	TR	2SC3423-Y	1	2202104
PCB U002	Q5074 or	TR	2SC3423-O	(1)	2202103
PCB U002	Q5075	TR	2SC3423-Y	1	2202104
PCB U002	Q5075 or	TR	2SC3423-O	(1)	2202103
PCB U002	Q5076	TR	2SC3423-Y	1	2202104
PCB U002	Q5076 or	TR	2SC3423-O	(1)	2202103
PCB U002	Q6601	TR	RN1226	1	2214680T
PCB U002	Q6602	TR	RN1226	1	2214680T
PCB U002	Q6603	TR	RN1226	1	2214680T
PCB U002	Q6604	TR	RN1226	1	2214680T
PCB U002	Q6605	TR	RN1226	1	2214680T
PCB U002	Q6606	TR	RN1226	1	2214680T
PCB U002	[TRANS COIL]				

PCB U002	L6600	S COIL	SC-0.8X11.5X12.5T-6.5L	1	231393S	
PCB U002	L6601	S COIL	SC-0.8X11.5X12.5T-6.5L	1	231393S	
PCB U002	L6602	S COIL	SC-0.8X11.5X12.5T-6.5L	1	231393S	
PCB U002	L6603	S COIL	SC-0.8X11.5X12.5T-6.5L	1	231393S	
PCB U002	L6604	S COIL	SC-0.8X11.5X12.5T-6.5L	1	231393S	
PCB U002	L6605	S COIL	SC-0.8X11.5X12.5T-6.5L	1	231393S	
PCB U002	L6606	S COIL	SC-0.8X11.5X12.5T-6.5L	1	231393S	
PCB U002	T902	P TRANS	NPT-1520JQ	1	2301812A	!, <MDD>
PCB U002	T902	P TRANS	NPT-1520GQ	1	2301813A	!, <MMA>
PCB U002	<b>[CAPACITOR]</b>					
PCB U002	C5000	UPZ C	2AUPZTF101JE	1	376331014T	
PCB U002	C5001	UPZ C	2AUPZTF101JE	1	376331014T	
PCB U002	C5002	UPZ C	2AUPZTF101JE	1	376331014T	
PCB U002	C5003	UPZ C	2AUPZTF101JE	1	376331014T	
PCB U002	C5004	UPZ C	2AUPZTF101JE	1	376331014T	
PCB U002	C5005	UPZ C	2AUPZTF101JE	1	376331014T	
PCB U002	C5006	UPZ C	2AUPZTF101JE	1	376331014T	
PCB U002	C5010	UTSJ C	CE04W25V-47M(UTSJ)	1	398054707T	
PCB U002	C5011	UTSJ C	CE04W25V-47M(UTSJ)	1	398054707T	
PCB U002	C5012	UTSJ C	CE04W25V-47M(UTSJ)	1	398054707T	
PCB U002	C5013	UTSJ C	CE04W25V-47M(UTSJ)	1	398054707T	
PCB U002	C5014	UTSJ C	CE04W25V-47M(UTSJ)	1	398054707T	
PCB U002	C5015	UTSJ C	CE04W25V-47M(UTSJ)	1	398054707T	
PCB U002	C5016	UTSJ C	CE04W25V-47M(UTSJ)	1	398054707T	
PCB U002	C5020	UTSP C	CE04W50V-10M(UTSP)	1	397581007T	
PCB U002	C5021	UTSP C	CE04W50V-10M(UTSP)	1	397581007T	
PCB U002	C5022	UTSP C	CE04W50V-10M(UTSP)	1	397581007T	
PCB U002	C5023	UTSP C	CE04W50V-10M(UTSP)	1	397581007T	
PCB U002	C5024	UTSP C	CE04W50V-10M(UTSP)	1	397581007T	
PCB U002	C5025	UTSP C	CE04W50V-10M(UTSP)	1	397581007T	
PCB U002	C5026	UTSP C	CE04W50V-10M(UTSP)	1	397581007T	
PCB U002	C5040	UTSP C	CE04W10V-470M(UTSP)	1	397534717T	
PCB U002	C5041	UTSP C	CE04W10V-470M(UTSP)	1	397534717T	
PCB U002	C5042	UTSP C	CE04W10V-470M(UTSP)	1	397534717T	
PCB U002	C5043	UTSP C	CE04W10V-470M(UTSP)	1	397534717T	
PCB U002	C5044	UTSP C	CE04W10V-470M(UTSP)	1	397534717T	
PCB U002	C5045	UTSP C	CE04W10V-470M(UTSP)	1	397534717T	
PCB U002	C5046	UTSP C	CE04W10V-470M(UTSP)	1	397534717T	
PCB U002	C5050	UTSP C	CE04W50V 47M(UTSP)	1	397584707T	
PCB U002	C5051	UTSP C	CE04W50V 47M(UTSP)	1	397584707T	
PCB U002	C5052	UTSP C	CE04W50V 47M(UTSP)	1	397584707T	

PCB U002	C5053	UTSP C	CE04W50V 47M(UTSP)	1	397584707T
PCB U002	C5054	UTSP C	CE04W50V 47M(UTSP)	1	397584707T
PCB U002	C5055	UTSP C	CE04W50V 47M(UTSP)	1	397584707T
PCB U002	C5056	UTSP C	CE04W50V 47M(UTSP)	1	397584707T
PCB U002	C5080	CERA C	CC45SL50V-040C	1	345020401T
PCB U002	C5081	CERA C	CC45SL50V-040C	1	345020401T
PCB U002	C5082	CERA C	CC45SL50V-040C	1	345020401T
PCB U002	C5083	CERA C	CC45SL50V-040C	1	345020401T
PCB U002	C5084	CERA C	CC45SL50V-040C	1	345020401T
PCB U002	C5085	CERA C	CC45SL50V-040C	1	345020401T
PCB U002	C5086	CERA C	CC45SL50V-040C	1	345020401T
PCB U002	C5090	UPZ C	2AUPZTF101JE	1	376331014T
PCB U002	C5091	UPZ C	2AUPZTF101JE	1	376331014T
PCB U002	C5092	UPZ C	2AUPZTF101JE	1	376331014T
PCB U002	C5093	UPZ C	2AUPZTF101JE	1	376331014T
PCB U002	C5094	UPZ C	2AUPZTF101JE	1	376331014T
PCB U002	C5095	UPZ C	2AUPZTF101JE	1	376331014T
PCB U002	C5096	UPZ C	2AUPZTF101JE	1	376331014T
PCB U002	C5100	VR C	CE04W100V-22M(VR)	1	394692207T
PCB U002	C5101	VR C	CE04W100V-22M(VR)	1	394692207T
PCB U002	C5102	VR C	CE04W100V-22M(VR)	1	394692207T
PCB U002	C5103	VR C	CE04W100V-22M(VR)	1	394692207T
PCB U002	C5104	VR C	CE04W100V-22M(VR)	1	394692207T
PCB U002	C5105	VR C	CE04W100V-22M(VR)	1	394692207T
PCB U002	C5106	VR C	CE04W100V-22M(VR)	1	394692207T
PCB U002	C5110	VR C	CE04W100V-22M(VR)	1	394692207T
PCB U002	C5111	VR C	CE04W100V-22M(VR)	1	394692207T
PCB U002	C5112	VR C	CE04W100V-22M(VR)	1	394692207T
PCB U002	C5113	VR C	CE04W100V-22M(VR)	1	394692207T
PCB U002	C5114	VR C	CE04W100V-22M(VR)	1	394692207T
PCB U002	C5115	VR C	CE04W100V-22M(VR)	1	394692207T
PCB U002	C5116	VR C	CE04W100V-22M(VR)	1	394692207T
PCB U002	C6600	TF C	ECQ-V50V-103J	1	374721034T
PCB U002	C6602	TF C	ECQ-V50V-103J	1	374721034T
PCB U002	C6603	TF C	ECQ-V50V-103J	1	374721034T
PCB U002	C6605	TF C	ECQ-V50V-103J	1	374721034T
PCB U002	C6607	TF C	ECQ-V50V-103J	1	374721034T
PCB U002	C6609	TF C	ECQ-V50V-103J	1	374721034T
PCB U002	C6630	TF C	ECQ-V50V-473J	1	374724734T
PCB U002	C6631	TF C	ECQ-V50V-473J	1	374724734T
PCB U002	C6632	TF C	ECQ-V50V-473J	1	374724734T



PCB U002	C6633	TF C	ECQ-V50V-473J	1	374724734T	
PCB U002	C6634	TF C	ECQ-V50V-473J	1	374724734T	
PCB U002	C6635	TF C	ECQ-V50V-473J	1	374724734T	
PCB U002	C6636	TF C	ECQ-V50V-473J	1	374724734T	
PCB U002	C6639	MKT C	B32529C0472J289	1	376494724T	<MMA>
PCB U002	C6640	MKT C	B32529C0472J289	1	376494724T	<MMA>
PCB U002	C6641	MKT C	B32529C0472J289	1	376494724T	<MMA>
PCB U002	C6642	MKT C	B32529C0472J289	1	376494724T	<MMA>
PCB U002	C6643	MKT C	B32529C0472J289	1	376494724T	<MMA>
PCB U002	C6644	MKT C	B32529C0472J289	1	376494724T	<MMA>
PCB U002	C6645	MKT C	B32529C0472J289	1	376494724T	<MMA>
PCB U002	C6646	MKT C	B32529C0472J289	1	376494724T	<MMA>
PCB U002	C6647	MKT C	B32529C0472J289	1	376494724T	<MMA>
PCB U002	C6648	MKT C	B32529C0472J289	1	376494724T	<MMA>
PCB U002	C6649	MKT C	B32529C0472J289	1	376494724T	<MMA>
PCB U002	C6650	MKT C	B32529C0102J289	1	376491024T	
PCB U002	C6651	MKT C	B32529C0102J289	1	376491024T	
PCB U002	C6652	MKT C	B32529C0102J289	1	376491024T	
PCB U002	C6653	MKT C	B32529C0102J289	1	376491024T	
PCB U002	C6654	MKT C	B32529C0102J289	1	376491024T	
PCB U002	C6655	MKT C	B32529C0102J289	1	376491024T	
PCB U002	C6656	MKT C	B32529C0102J289	1	376491024T	
PCB U002	C6657	MKT C	B32529C0102J289	1	376491024T	
PCB U002	C6658	MKT C	B32529C0102J289	1	376491024T	
PCB U002	C6659	MKT C	B32529C0102J289	1	376491024T	
PCB U002	C6660	MKT C	B32529C0102J289	1	376491024T	
PCB U002	C901	IS C	ECQU2A103MLC	1	3800039S	!
PCB U002	C901 or	IS C	RE275V-103M	(1)	3500196S	!
PCB U002	C901 or	IS C	LE103-C3.5	(1)	3800042S	!
PCB U002	C902	TF C	ECQ-V50V-104J	1	374721044T	
PCB U002	C903	PLA C	MKP R46 104M	1	3800041S	
PCB U002	C911	MKT C	B32529C0102J289	1	376491024T	
PCB U002	C921	TF C	ECQ-V50V-223J	1	374722234T	
PCB U002	C922	UTSP C	CE04W25V-470M(UTSP)	1	397554717T	
PCB U002	C930	UTSP C	CE04W25V-220M(UTSP)	1	397552217T	
PCB U002	C933	UTSP C	CE04W50V-4.7M(UTSP)	1	397580477T	
PCB U002	<b>[RESISTOR]</b>					
PCB U002	R5000	CARBON R	R16J-1.5K	1	417341524T	
PCB U002	R5001	CARBON R	R16J-1.5K	1	417341524T	
PCB U002	R5002	CARBON R	R16J-1.5K	1	417341524T	
PCB U002	R5003	CARBON R	R16J-1.5K	1	417341524T	

PCB U002	R5004	CARBON R	R16J-1.5K	1	417341524T
PCB U002	R5005	CARBON R	R16J-1.5K	1	417341524T
PCB U002	R5006	CARBON R	R16J-1.5K	1	417341524T
PCB U002	R5010	CARBON R	R16J-33K	1	417343334T
PCB U002	R5011	CARBON R	R16J-33K	1	417343334T
PCB U002	R5012	CARBON R	R16J-33K	1	417343334T
PCB U002	R5013	CARBON R	R16J-33K	1	417343334T
PCB U002	R5014	CARBON R	R16J-33K	1	417343334T
PCB U002	R5015	CARBON R	R16J-33K	1	417343334T
PCB U002	R5016	CARBON R	R16J-33K	1	417343334T
PCB U002	R5020	CARBON R	R16J-330	1	417343314T
PCB U002	R5021	CARBON R	R16J-330	1	417343314T
PCB U002	R5022	CARBON R	R16J-330	1	417343314T
PCB U002	R5023	CARBON R	R16J-330	1	417343314T
PCB U002	R5024	CARBON R	R16J-330	1	417343314T
PCB U002	R5025	CARBON R	R16J-330	1	417343314T
PCB U002	R5026	CARBON R	R16J-330	1	417343314T
PCB U002	R5030	CARBON R	R16J-33K	1	417343334T
PCB U002	R5031	CARBON R	R16J-33K	1	417343334T
PCB U002	R5032	CARBON R	R16J-33K	1	417343334T
PCB U002	R5033	CARBON R	R16J-33K	1	417343334T
PCB U002	R5034	CARBON R	R16J-33K	1	417343334T
PCB U002	R5035	CARBON R	R16J-33K	1	417343334T
PCB U002	R5036	CARBON R	R16J-33K	1	417343334T
PCB U002	R5040	CARBON R	R16J-1K	1	417341024T
PCB U002	R5041	CARBON R	R16J-1K	1	417341024T
PCB U002	R5042	CARBON R	R16J-1K	1	417341024T
PCB U002	R5043	CARBON R	R16J-1K	1	417341024T
PCB U002	R5044	CARBON R	R16J-1K	1	417341024T
PCB U002	R5045	CARBON R	R16J-1K	1	417341024T
PCB U002	R5046	CARBON R	R16J-1K	1	417341024T
PCB U002	R5050	CARBON R	R16J-5.6K	1	417345624T
PCB U002	R5051	CARBON R	R16J-5.6K	1	417345624T
PCB U002	R5052	CARBON R	R16J-5.6K	1	417345624T
PCB U002	R5053	CARBON R	R16J-5.6K	1	417345624T
PCB U002	R5054	CARBON R	R16J-5.6K	1	417345624T
PCB U002	R5055	CARBON R	R16J-5.6K	1	417345624T
PCB U002	R5056	CARBON R	R16J-5.6K	1	417345624T
PCB U002	R5060	CARBON R	R16J-2.7K	1	417342724T
PCB U002	R5061	CARBON R	R16J-2.7K	1	417342724T
PCB U002	R5062	CARBON R	R16J-2.7K	1	417342724T

PCB U002	R5063	CARBON R	R16J-2.7K	1	417342724T
PCB U002	R5064	CARBON R	R16J-2.7K	1	417342724T
PCB U002	R5065	CARBON R	R16J-2.7K	1	417342724T
PCB U002	R5066	CARBON R	R16J-2.7K	1	417342724T
PCB U002	R5080	NF CARBON R	R25J-1.0K	1	415471024T
PCB U002	R5081	NF CARBON R	R25J-1.0K	1	415471024T
PCB U002	R5082	NF CARBON R	R25J-1.0K	1	415471024T
PCB U002	R5083	NF CARBON R	R25J-1.0K	1	415471024T
PCB U002	R5084	NF CARBON R	R25J-1.0K	1	415471024T
PCB U002	R5085	NF CARBON R	R25J-1.0K	1	415471024T
PCB U002	R5086	NF CARBON R	R25J-1.0K	1	415471024T
PCB U002	R5090	CARBON R	R16J-100K	1	417341044T
PCB U002	R5091	CARBON R	R16J-100K	1	417341044T
PCB U002	R5092	CARBON R	R16J-100K	1	417341044T
PCB U002	R5093	CARBON R	R16J-100K	1	417341044T
PCB U002	R5094	CARBON R	R16J-100K	1	417341044T
PCB U002	R5095	CARBON R	R16J-100K	1	417341044T
PCB U002	R5096	CARBON R	R16J-100K	1	417341044T
PCB U002	R5100	CARBON R	R16J-100K	1	417341044T
PCB U002	R5101	CARBON R	R16J-100K	1	417341044T
PCB U002	R5102	CARBON R	R16J-100K	1	417341044T
PCB U002	R5103	CARBON R	R16J-100K	1	417341044T
PCB U002	R5104	CARBON R	R16J-100K	1	417341044T
PCB U002	R5105	CARBON R	R16J-100K	1	417341044T
PCB U002	R5106	CARBON R	R16J-100K	1	417341044T
PCB U002	R5110	CARBON R	R16J-2.2K	1	417342224T
PCB U002	R5111	CARBON R	R16J-2.2K	1	417342224T
PCB U002	R5112	CARBON R	R16J-2.2K	1	417342224T
PCB U002	R5113	CARBON R	R16J-2.2K	1	417342224T
PCB U002	R5114	CARBON R	R16J-2.2K	1	417342224T
PCB U002	R5115	CARBON R	R16J-2.2K	1	417342224T
PCB U002	R5116	CARBON R	R16J-2.2K	1	417342224T
PCB U002	R5120	CARBON R	R16J-2.2K	1	417342224T
PCB U002	R5121	CARBON R	R16J-2.2K	1	417342224T
PCB U002	R5122	CARBON R	R16J-2.2K	1	417342224T
PCB U002	R5123	CARBON R	R16J-2.2K	1	417342224T
PCB U002	R5124	CARBON R	R16J-2.2K	1	417342224T
PCB U002	R5125	CARBON R	R16J-2.2K	1	417342224T
PCB U002	R5126	CARBON R	R16J-2.2K	1	417342224T
PCB U002	R5130	CARBON R	R16J-18K	1	417341834T
PCB U002	R5131	CARBON R	R16J-18K	1	417341834T

PCB U002	R5132	CARBON R	R16J-18K	1	417341834T
PCB U002	R5133	CARBON R	R16J-18K	1	417341834T
PCB U002	R5134	CARBON R	R16J-18K	1	417341834T
PCB U002	R5135	CARBON R	R16J-18K	1	417341834T
PCB U002	R5136	CARBON R	R16J-18K	1	417341834T
PCB U002	R5140	NF CARBON R	R25J-820	1	415478214T
PCB U002	R5141	NF CARBON R	R25J-820	1	415478214T
PCB U002	R5142	NF CARBON R	R25J-820	1	415478214T
PCB U002	R5143	NF CARBON R	R25J-820	1	415478214T
PCB U002	R5144	NF CARBON R	R25J-820	1	415478214T
PCB U002	R5145	NF CARBON R	R25J-820	1	415478214T
PCB U002	R5146	NF CARBON R	R25J-820	1	415478214T
PCB U002	R5150	NF CARBON R	R25J-1.0K	1	415471024T
PCB U002	R5151	NF CARBON R	R25J-1.0K	1	415471024T
PCB U002	R5152	NF CARBON R	R25J-1.0K	1	415471024T
PCB U002	R5153	NF CARBON R	R25J-1.0K	1	415471024T
PCB U002	R5154	NF CARBON R	R25J-1.0K	1	415471024T
PCB U002	R5155	NF CARBON R	R25J-1.0K	1	415471024T
PCB U002	R5156	NF CARBON R	R25J-1.0K	1	415471024T
PCB U002	R5160	NF CARBON R	R25J-820	1	415478214T
PCB U002	R5161	NF CARBON R	R25J-820	1	415478214T
PCB U002	R5162	NF CARBON R	R25J-820	1	415478214T
PCB U002	R5163	NF CARBON R	R25J-820	1	415478214T
PCB U002	R5164	NF CARBON R	R25J-820	1	415478214T
PCB U002	R5165	NF CARBON R	R25J-820	1	415478214T
PCB U002	R5166	NF CARBON R	R25J-820	1	415478214T
PCB U002	R5170	NF CARBON R	R25J-820	1	415478214T
PCB U002	R5171	NF CARBON R	R25J-820	1	415478214T
PCB U002	R5172	NF CARBON R	R25J-820	1	415478214T
PCB U002	R5173	NF CARBON R	R25J-820	1	415478214T
PCB U002	R5174	NF CARBON R	R25J-820	1	415478214T
PCB U002	R5175	NF CARBON R	R25J-820	1	415478214T
PCB U002	R5176	NF CARBON R	R25J-820	1	415478214T
PCB U002	R5180	NF CARBON R	R25J-10	1	415471004T
PCB U002	R5181	NF CARBON R	R25J-10	1	415471004T
PCB U002	R5182	NF CARBON R	R25J-10	1	415471004T
PCB U002	R5183	NF CARBON R	R25J-10	1	415471004T
PCB U002	R5184	NF CARBON R	R25J-10	1	415471004T
PCB U002	R5185	NF CARBON R	R25J-10	1	415471004T
PCB U002	R5186	NF CARBON R	R25J-10	1	415471004T
PCB U002	R5190	NF CARBON R	R25J-10	1	415471004T

PCB U002	R5191	NF CARBON R	R25J-10	1	415471004T
PCB U002	R5192	NF CARBON R	R25J-10	1	415471004T
PCB U002	R5193	NF CARBON R	R25J-10	1	415471004T
PCB U002	R5194	NF CARBON R	R25J-10	1	415471004T
PCB U002	R5195	NF CARBON R	R25J-10	1	415471004T
PCB U002	R5196	NF CARBON R	R25J-10	1	415471004T
PCB U002	R5200	CARBON R	R16J-18K	1	417341834T
PCB U002	R5201	CARBON R	R16J-18K	1	417341834T
PCB U002	R5202	CARBON R	R16J-18K	1	417341834T
PCB U002	R5203	CARBON R	R16J-18K	1	417341834T
PCB U002	R5204	CARBON R	R16J-18K	1	417341834T
PCB U002	R5205	CARBON R	R16J-18K	1	417341834T
PCB U002	R5206	CARBON R	R16J-18K	1	417341834T
PCB U002	R5210	NF CARBON R	R25J-120	1	415471214T
PCB U002	R5211	NF CARBON R	R25J-120	1	415471214T
PCB U002	R5212	NF CARBON R	R25J-120	1	415471214T
PCB U002	R5213	NF CARBON R	R25J-120	1	415471214T
PCB U002	R5214	NF CARBON R	R25J-120	1	415471214T
PCB U002	R5215	NF CARBON R	R25J-120	1	415471214T
PCB U002	R5216	NF CARBON R	R25J-120	1	415471214T
PCB U002	R5220	NF CARBON R	R25J-120	1	415471214T
PCB U002	R5221	NF CARBON R	R25J-120	1	415471214T
PCB U002	R5222	NF CARBON R	R25J-120	1	415471214T
PCB U002	R5223	NF CARBON R	R25J-120	1	415471214T
PCB U002	R5224	NF CARBON R	R25J-120	1	415471214T
PCB U002	R5225	NF CARBON R	R25J-120	1	415471214T
PCB U002	R5226	NF CARBON R	R25J-120	1	415471214T
PCB U002	R5300	CARBON R	R16J-330	1	417343314T
PCB U002	R5301	CARBON R	R16J-330	1	417343314T
PCB U002	R5302	CARBON R	R16J-330	1	417343314T
PCB U002	R5303	CARBON R	R16J-330	1	417343314T
PCB U002	R5304	CARBON R	R16J-330	1	417343314T
PCB U002	R5305	CARBON R	R16J-330	1	417343314T
PCB U002	R5306	CARBON R	R16J-330	1	417343314T
PCB U002	R5310	CARBON R	R16J-330	1	417343314T
PCB U002	R5311	CARBON R	R16J-330	1	417343314T
PCB U002	R5312	CARBON R	R16J-330	1	417343314T
PCB U002	R5313	CARBON R	R16J-330	1	417343314T
PCB U002	R5314	CARBON R	R16J-330	1	417343314T
PCB U002	R5315	CARBON R	R16J-330	1	417343314T
PCB U002	R5316	CARBON R	R16J-330	1	417343314T

PCB U002	R6600	CARBON R	R16J-22	1	417342204T	
PCB U002	R6601	CARBON R	R16J-22	1	417342204T	
PCB U002	R6602	CARBON R	R16J-22	1	417342204T	
PCB U002	R6603	CARBON R	R16J-22	1	417342204T	
PCB U002	R6604	CARBON R	R16J-22	1	417342204T	
PCB U002	R6605	CARBON R	R16J-22	1	417342204T	
PCB U002	R6606	CARBON R	R16J-22	1	417342204T	
PCB U002	R6610	CARBON R	R16J-22	1	417342204T	
PCB U002	R6611	CARBON R	R16J-22	1	417342204T	
PCB U002	R6612	CARBON R	R16J-22	1	417342204T	
PCB U002	R6613	CARBON R	R16J-22	1	417342204T	
PCB U002	R6614	CARBON R	R16J-22	1	417342204T	
PCB U002	R6615	CARBON R	R16J-22	1	417342204T	
PCB U002	R6616	CARBON R	R16J-22	1	417342204T	
PCB U002	R6630	METAL R	RNU1WCJ-8.2	1	453630824T	
PCB U002	R6631	METAL R	RNU1WCJ-8.2	1	453630824T	
PCB U002	R6632	METAL R	RNU1WCJ-8.2	1	453630824T	
PCB U002	R6633	METAL R	RNU1WCJ-8.2	1	453630824T	
PCB U002	R6634	METAL R	RNU1WCJ-8.2	1	453630824T	
PCB U002	R6635	METAL R	RNU1WCJ-8.2	1	453630824T	
PCB U002	R6636	METAL R	RNU1WCJ-8.2	1	453630824T	
PCB U002	R6690	METAL R	RNU1WCJ-8.2	1	453630824T	
PCB U002	R6691	METAL O R	RS1/2WBJ-390	1	443523914T	
PCB U002	R6692	METAL O R	RS1/2WBJ-390	1	443523914T	
PCB U002	R921	METAL O R	RS1/2WBJ-47	1	443524704T	
PCB U002	R922	METAL O R	RS1/2WBJ-68	1	443526804T	
PCB U002	R934	CARBON R	R16J-33K	1	417343334T	
PCB U002	[SW TRM]					
PCB U002	E5507B	TRM	NTM-1P233(M1969)	1	25060302	
PCB U002	E5509B	TRM	NTM-1P233(M1969)	1	25060302	
PCB U002	E6611	TRM	NTM-1P232(M1700)	1	25060301	
PCB U002	E6612	TRM-423(SCREW)	NEJITANSI ST3	1	25060495	
PCB U002	E901	TRM-423(SCREW)	NEJITANSI ST3	1	25060495	
PCB U002	E902	TRM	NTM-1P233(M1969)	1	25060302	
PCB U002	F901A	FUSE HOLDER	SN5051	1	250113	!, <MDD>
PCB U002	F901B	FUSE HOLDER	SN5051	1	250113	!, <MDD>
PCB U002	F901C	FUSE HOL	NSCT-1P2031	1	25052133T	!, <MMA>
PCB U002	F901D	FUSE HOL	NSCT-1P2031	1	25052133T	!, <MMA>
PCB U002	JL4103A	SOCKET	NSCT-5P97	1	25050269	
PCB U002	JL6600B	SOCKET	NSCT-7P99	1	25050271	
PCB U002	JL6603B	SOCKET	NSCT-9P101	1	25050273	

PCB U002	JL6604A	WIRE HOL	NSCT-11P882	1	25051095	
PCB U002	JL6604B	WIRE TRAP	NPLG-11P594	1	25055632	
PCB U002	JL6606A	WIRE HOL	NSCT-7P878	1	25051091	
PCB U002	JL6607A	WIRE HOL	NSCT-3P874	1	25051087	
PCB U002	JL6607B	WIRE HOL	NSCT-3P874	1	25051087	
PCB U002	JL6620B	WIRE TRAP	NPLG-7P590	1	25055628	
PCB U002	JL901A	WIRE HOL	NSCT-5P876	1	25051089	
PCB U002	P001	PWB	BCTRM-0083	1	25140083B	N
PCB U002	P002	PWB	BCPS-0084	{ 1 }	25140084	N
PCB U002	P003	PWB	BCTRM-0085	{ 1 }	25140085	N
PCB U002	P004	PWB	BCTRM-0086	{ 1 }	25140086	
PCB U002	P005	PWB	BCCLA-0087	{ 1 }	25140087	
PCB U002	P1008B	SOCKET	IMSA-9142S-20A	1	25053232	
PCB U002	P1010B	SOCKET	IMSA-9142S-20A	1	25053232	
PCB U002	P6000A	SOCKET	NSCT-7P2187	1	25052290	
PCB U002	P6001A	SOCKET	NSCT-7P2187	1	25052290	
PCB U002	P6002A	SOCKET	NSCT-7P2187	1	25052290	
PCB U002	P6003A	SOCKET	NSCT-7P2187	1	25052290	
PCB U002	P6004A	SOCKET	NSCT-7P2187	1	25052290	
PCB U002	P6005A	SOCKET	NSCT-7P2187	1	25052290	
PCB U002	P6006A	SOCKET	NSCT-7P2187	1	25052290	
PCB U002	P6600	TRM	NTM-2PDMCR400	1	25060472	
PCB U002	P6601	TRM	NTM-2PDMCR400	1	25060472	
PCB U002	P6602	TRM	NTM-2PDMCR400	1	25060472	
PCB U002	P6603	TRM	NTM-2PDMCR400	1	25060472	
PCB U002	P6604	TRM	NTM-2PDMCR400	1	25060472	
PCB U002	P6605	TRM	NTM-2PDMCR400	1	25060472	
PCB U002	P6606	TRM	NTM-2PDMCR400	1	25060472	
PCB U002	P6607	TRM	NTM-2PDMCR400	1	25060472	
PCB U002	P6608	TRM	NTM-2PDMCR400	1	25060472	
PCB U002	P6609	TRM	NTM-2PDMCR400	1	25060472	
PCB U002	P6610	TRM	NTM-2PDMCR400	1	25060472	
PCB U002	P6621	SOCKET	IMSA-9142S-16A	1	25053230	
PCB U002	P902B	PLUG	NPLG-2P631	1	25055675	!
PCB U002	P902Bor	PLUG	1-1123724-2	( 1 )	25056402	!
PCB U002	P911	PLUG	NPLG-2P631	1	25055675	!
PCB U002	P911 or	PLUG	1-1123724-2	( 1 )	25056402	!
PCB U002	P921C	PLUG	NPLG-2P631	1	25055675	!
PCB U002	P921Cor	PLUG	1-1123724-2	( 1 )	25056402	!
PCB U002	RL6600	RELAY	NRL-2P5A-DC24-193	1	25065703	
PCB U002	RL6602	RELAY	NRL-2P5A-DC24-193	1	25065703	

PCB U002	RL6603	RELAY	NRL-2P5A-DC24-193	1	25065703	
PCB U002	RL6605	RELAY	NRL-2P5A-DC24-193	1	25065703	
PCB U002	RL6607	RELAY	NRL-2P5A-DC24-193	1	25065703	
PCB U002	RL6609	RELAY	NRL-2P5A-DC24-193	1	25065703	
PCB U002	RL901	RELAY	NRL-1P10A-DC9-186	1	25065683	!
PCB U002	<b>[TUNER UNIT]</b>					
PCB U002	Q5030A	RETAINER	(CLA)	1	27142123	
PCB U002	Q5031A	RETAINER	(CLA)	1	27142123	
PCB U002	Q5032A	RETAINER	(CLA)	1	27142123	
PCB U002	Q5033A	RETAINER	(CLA)	1	27142123	
PCB U002	Q5034A	RETAINER	(CLA)	1	27142123	
PCB U002	Q5035A	RETAINER	(CLA)	1	27142123	
PCB U002	Q5036A	RETAINER	(CLA)	1	27142123	
PCB U003	<b>U0030</b>	DAC/ DIR CIRCUIT PC BOARD (BADG-0099-1K/ 1L)				
PCB U003	<b>U0031</b>	CPU CIRCUIT PC BOARD (BACPU-0100-1K/ 1L)				
PCB U003	<b>U0032</b>	VIDEO CIRCUIT PC BOARD (BAVD-0101-1K/ 1L)				
PCB U003	<b>U0033</b>	UNIVERSAL PORT PC BOARD (BAETC-0103-1K/ 1L)				
PCB U003						
PCB U003	<b>CIRCUIT. NO.</b>	<b>PART NAME</b>	<b>DESCRIPTION</b>	<b>Q'TY</b>	<b>PART NO. (SN)</b>	<b>REMARKS</b>
PCB U003	<b>[TUNER UNIT]</b>					
PCB U003	U1100	REMO SENS	KSM-603TE2Q	1	24130018	
PCB U003	U1301	PHT CP	JSR1165-001recieving	1	24120143	
PCB U003	U1302	PHT CP	JSR1165-001recieving	1	24120143	
PCB U003	<b>[SEMI CONDUCTOR]</b>					
PCB U003	D1001	C-DIODE	1SS352	1	223234R2	
PCB U003	D1001 or	C-DIODE	MA2J111	(1)	223279R2	
PCB U003	D1001 or	C-DIODE	KDS4148U	(1)	223283R2	
PCB U003	D1002	C-DIODE	1SS352	1	223234R2	
PCB U003	D1002 or	C-DIODE	MA2J111	(1)	223279R2	
PCB U003	D1002 or	C-DIODE	KDS4148U	(1)	223283R2	
PCB U003	D1005	C-DIODE	1SS352	1	223234R2	
PCB U003	D1005 or	C-DIODE	MA2J111	(1)	223279R2	
PCB U003	D1005 or	C-DIODE	KDS4148U	(1)	223283R2	
PCB U003	D1007	C-DIODE	1SS352	1	223234R2	
PCB U003	D1007 or	C-DIODE	MA2J111	(1)	223279R2	
PCB U003	D1007 or	C-DIODE	KDS4148U	(1)	223283R2	
PCB U003	D1100	SPCF D	SIR-34ST3F	1	225456	
PCB U003	D1101	SPCF D	SIR-34ST3F	1	225456	
PCB U003	D4001	C-DIODE	1SS352	1	223234R2	
PCB U003	D4001 or	C-DIODE	MA2J111	(1)	223279R2	



PCB U003	D4001 or	C-DIODE	KDS4148U	(1)	223283R2	
PCB U003	D4002	ZENER D	UDZS5.6B	1	224550560R2	
PCB U003	D4002 or	ZENER D	MAZ8056-M	(1)	224750562R2	
PCB U003	D4003	C-DIODE	ISS352	1	223234R2	
PCB U003	D4003 or	C-DIODE	MA2J111	(1)	223279R2	
PCB U003	D4003 or	C-DIODE	KDS4148U	(1)	223283R2	
PCB U003	D4004	DIODE	D5SBA20	1	22380130F	
PCB U003	D4005	DIODE	RB070M-30	1	22380361R2	
PCB U003	D4006	DIODE	RL1N4003	1	22380260T	
PCB U003	D4009	DIODE	D3SBA20	1	22380271F	
PCB U003	D4010	C-DIODE	ISS352	1	223234R2	
PCB U003	D4010 or	C-DIODE	MA2J111	(1)	223279R2	
PCB U003	D4010 or	C-DIODE	KDS4148U	(1)	223283R2	
PCB U003	D4015	C-DIODE	ISS352	1	223234R2	
PCB U003	D4015 or	C-DIODE	MA2J111	(1)	223279R2	
PCB U003	D4015 or	C-DIODE	KDS4148U	(1)	223283R2	
PCB U003	D4016	C-DIODE	ISS352	1	223234R2	
PCB U003	D4016 or	C-DIODE	MA2J111	(1)	223279R2	
PCB U003	D4016 or	C-DIODE	KDS4148U	(1)	223283R2	
PCB U003	D4017	ZENER D	UDZS3.3B	1	224550330R2	
PCB U003	D4500	C-DIODE	ISS352	1	223234R2	
PCB U003	D4500 or	C-DIODE	MA2J111	(1)	223279R2	
PCB U003	D4500 or	C-DIODE	KDS4148U	(1)	223283R2	
PCB U003	D4501	C-DIODE	ISS352	1	223234R2	
PCB U003	D4501 or	C-DIODE	MA2J111	(1)	223279R2	
PCB U003	D4501 or	C-DIODE	KDS4148U	(1)	223283R2	
PCB U003	D4606	DIODE	RL1N4003	1	22380260T	
PCB U003	Q10	IC	NJM4580M-D	1	22241448R2	<MDD>
PCB U003	Q1001	TR	KRC104S	1	2216210R2	
PCB U003	Q1001 or	TR	RN1404	(1)	2214490R2	
PCB U003	Q1002	TR	KRA102S	1	2216220R2	
PCB U003	Q1002 or	TR	RN2402	(1)	2214530R2	
PCB U003	Q1003	TR	KRC104S	1	2216210R2	
PCB U003	Q1003 or	TR	RN1404	(1)	2214490R2	
PCB U003	Q1004	TR	KRA102S	1	2216220R2	
PCB U003	Q1004 or	TR	RN2402	(1)	2214530R2	
PCB U003	Q1005	TR	KRC102S	1	2216190R2	
PCB U003	Q1005 or	TR	RN1402	(1)	2214470R2	
PCB U003	Q1005 or	TR	DTC114EKA	(1)	2216250R2	
PCB U003	Q1006	TR	KRA107S	1	2216350R2	
PCB U003	Q1006 or	TR	RN2407(TE85L_F)	(1)	2216360R2	

PCB U003	Q1006 or	TR	DTA114YKA	(1)	2216480R2	
PCB U003	Q1007	TR	KRC102S	1	2216190R2	
PCB U003	Q1007 or	TR	RN1402	(1)	2214470R2	
PCB U003	Q1007 or	TR	DTC114EKA	(1)	2216250R2	
PCB U003	Q1008	TR	KRA107S	1	2216350R2	
PCB U003	Q1008 or	TR	RN2407(TE85L_F)	(1)	2216360R2	
PCB U003	Q1008 or	TR	DTA114YKA	(1)	2216480R2	
PCB U003	Q1009	TR	KRC102S	1	2216190R2	
PCB U003	Q1009 or	TR	RN1402	(1)	2214470R2	
PCB U003	Q1009 or	TR	DTC114EKA	(1)	2216250R2	
PCB U003	Q101	IC	LC72725KV-TLM-E	1	22242584R2	<MMA>
PCB U003	Q1010	TR	KRC104S	1	2216210R2	
PCB U003	Q1010 or	TR	RN1404	(1)	2214490R2	
PCB U003	Q1011	TR	KRA102S	1	2216220R2	
PCB U003	Q1011 or	TR	RN2402	(1)	2214530R2	
PCB U003	Q1016	IC (MAIN MICROPROCESSOR)	MPD70F3746GJ-GAE-AX (0298)	1	222W0079R302980	
PCB U003	Q1017	IC	XC6202P502FR	1	22242331R2	
PCB U003	Q1018	IC	XC6213B332MR	1	22242277R2	
PCB U003	Q1019	IC	S-812C33AUA-C2N	1	22242222R2	
PCB U003	Q102	IC	S-812C33AUA-C2N	1	22242222R2	<MMA>
PCB U003	Q1020	IC	S-812C56AUA-C3K	1	22242207R2	
PCB U003	Q1022	IC	RIEX25064ASA00A	1	22242581R2	
PCB U003	Q1023	IC	NJU7706F27A3	1	22242614R2	
PCB U003	Q1027	TR	KRA102S	1	2216220R2	
PCB U003	Q1028	TR	KRC104S	1	2216210R2	
PCB U003	Q1029	TR	KRA102S	1	2216220R2	
PCB U003	Q1030	TR	KRC104S	1	2216210R2	
PCB U003	Q1031	TR	KRA102S	1	2216220R2	
PCB U003	Q1032	TR	KRC104S	1	2216210R2	
PCB U003	Q1033	TR	KRA102S	1	2216220R2	
PCB U003	Q1034	TR	KRC104S	1	2216210R2	
PCB U003	Q1035	TR	KRA102S	1	2216220R2	
PCB U003	Q1036	TR	KRC104S	1	2216210R2	
PCB U003	Q1037	TR	KRA102S	1	2216220R2	
PCB U003	Q1038	TR	KRC104S	1	2216210R2	
PCB U003	Q1101	IC	S3F80K9	1	22242602R3	
PCB U003	Q1102	TR	2SC2712-GR	1	2213145R2	
PCB U003	Q1290	TR	2SC2712-GR	1	2213145R2	
PCB U003	Q1291	IC	TC4066BFT	1	22284066MR2TO	
PCB U003	Q1292	TR	2SC2712-GR	1	2213145R2	
PCB U003	Q1301	IC	TA4805BF(TE16L_NQ)	1	22278005DBR2TO	

PCB U003	Q1301A	RETAINER	(REG)	1	27142168	N
PCB U003	Q1302	IC	TA48033BF(TE16L_NQ)	1	22278033DBR2TO	
PCB U003	Q1311	IC	TC74VHC157FT	1	22274157ER2TO	
PCB U003	Q1322	IC	TC74VHCT00AFT (EKJ)	1	22274000G1R2TO	
PCB U003	Q1322 or	IC	TC74VHCT00AFT	(1)	22274000GR2TO	
PCB U003	Q1324	IC	CS42516-CQZ(R)-D	1	22242294R2	
PCB U003	Q1325	IC	74HCU04F	1	222740046R2	
PCB U003	Q1325 or	IC	TC74HCU04AF	(1)	222740046R2TO	
PCB U003	Q1327	IC	TC7WU04FU(TE12L_F)	1	22240935R2	
PCB U003	Q1421	IC	PCM1690DCAR	1	22242599R2	N
PCB U003	Q1601	IC	NJM4580M-D	1	22241448R2	
PCB U003	Q1602	IC	NJM4580M-D	1	22241448R2	
PCB U003	Q1603	IC	NJM4580M-D	1	22241448R2	
PCB U003	Q1604	IC	NJM4580M-D	1	22241448R2	
PCB U003	Q1800	IC	NJM4580M-D	1	22241448R2	
PCB U003	Q1801	IC	NJM4580M-D	1	22241448R2	
PCB U003	Q1904	IC	NJM4580M-D	1	22241448R2	
PCB U003	Q1940	IC	XC6202P502FR	1	22242331R2	
PCB U003	Q1950	IC	NJM2505AF	1	22242490R2	
PCB U003	Q1960	IC	NJM2505AF	1	22242490R2	
PCB U003	Q1970	IC	NJM2505AF	1	22242490R2	
PCB U003	Q2	IC	78M09HF(NJM78M09FA)	1	222780095JRC	
PCB U003	Q4000	TR	KRC105S	1	2217290R2	
PCB U003	Q4000 or	TR	RN1405	(1)	2214500R2	
PCB U003	Q4001	IC	78M05(NJM78M05FA)	1	222780055JRC	
PCB U003	Q4002	IC	SI8008TM	1	22242323R2	
PCB U003	Q4003	TR	KRC105S	1	2217290R2	
PCB U003	Q4003 or	TR	RN1405	(1)	2214500R2	
PCB U003	Q4100	IC	NJW1325	1	22242596R3	
PCB U003	Q4101	TR ARRAY	UM6K1N	1	226066R2	
PCB U003	Q4500	TR	2SA950-Y	1	2211504T	
PCB U003	Q4500 or	TR	2SA950-O	(1)	2211503T	
PCB U003	Q4501	TR	2SC1815-GR	1	2211255T	
PCB U003	Q4502	TR	2SA950-Y	1	2211504T	
PCB U003	Q4502 or	TR	2SA950-O	(1)	2211503T	
PCB U003	Q4503	TR	2SC1815-GR	1	2211255T	
PCB U003	Q4504	TR	2SA854S-R	1	2217394T	
PCB U003	Q4504 or	TR	2SB1240-R	(1)	2213794T	
PCB U003	Q4700	IC	ICL3221ECVZ	1	22242268R2	
PCB U003	Q9	IC	NJM4580M-D	1	22241448R2	
PCB U003	[TRANS COIL]					

PCB U003	L1090	CHOKE COIL	BLM21PG221SN1	1	230949R2
PCB U003	L1290	CHOKE COIL	LBC2518T470M	1	231364M470R2
PCB U003	L1301	CHOKE COIL	LBC2518T470M	1	231364M470R2
PCB U003	L1305	CHOKE COIL	LBC2518T2R2M	1	231364M022R2
PCB U003	L1306	CHOKE COIL	LBC2518T470M	1	231364M470R2
PCB U003	L1307	CHOKE COIL	LBC2518T2R2M	1	231364M022R2
PCB U003	L1308	CHOKE COIL	LBC2518T2R2M	1	231364M022R2
PCB U003	L1309	CHOKE COIL	LBC2518T4R7M	1	231364M047R2
PCB U003	L1312	CHOKE COIL	LBC2518T470M	1	231364M470R2
PCB U003	L1313	CHOKE COIL	LBC2518T4R7M	1	231364M047R2
PCB U003	L1314	CHOKE COIL	LBC2518T4R7M	1	231364M047R2
PCB U003	L1315	CHOKE COIL	LBC2518T4R7M	1	231364M047R2
PCB U003	L1316	EMIFIL	BK1608LM182-T	1	230958R1
PCB U003	L1317	EMIFIL	BK1608LM182-T	1	230958R1
PCB U003	L1318	CHOKE COIL	LBC2518T470M	1	231364M470R2
PCB U003	L1319	CHOKE COIL	LBC2518T470M	1	231364M470R2
PCB U003	L1320	EMIFIL	BK1608LM182-T	1	230958R1
PCB U003	L1321	EMIFIL	BK1608LM182-T	1	230958R1
PCB U003	L1322	EMIFIL	BK1608LM182-T	1	230958R1
PCB U003	L1323	EMIFIL	BK1608HS102-T	1	230955R2
PCB U003	L1324	EMIFIL	BK1608HS102-T	1	230955R2
PCB U003	L1325	EMIFIL	BK1608HS102-T	1	230955R2
PCB U003	L1404	CHOKE COIL	LBC2518T4R7M	1	231364M047R2
PCB U003	L1407	CHOKE COIL	LBC2518T4R7M	1	231364M047R2
PCB U003	L1900	CHOKE COIL	BLM21PG221SN1	1	230949R2
PCB U003	L1901	CHOKE COIL	BLM21PG221SN1	1	230949R2
PCB U003	L1902	EMIFIL	BK1608LM182-T	1	230958R1
PCB U003	L1903	EMIFIL	BK1608LM182-T	1	230958R1
PCB U003	L1904	EMIFIL	BK1608LM182-T	1	230958R1
PCB U003	L1905	EMIFIL	BK1608LM182-T	1	230958R1
PCB U003	L1906	CHOKE COIL	BLM21PG221SN1	1	230949R2
PCB U003	L1907	CHOKE COIL	BLM21PG221SN1	1	230949R2
PCB U003	L1908	EMIFIL	BK1608LM182-T	1	230958R1
PCB U003	L1909	EMIFIL	BK1608LM182-T	1	230958R1
PCB U003	L1910	EMIFIL	BK1608LM182-T	1	230958R1
PCB U003	L1911	EMIFIL	BK1608LM182-T	1	230958R1
PCB U003	L1912	EMIFIL	BK1608LM182-T	1	230958R1
PCB U003	L1913	EMIFIL	BK1608LM182-T	1	230958R1
PCB U003	L1914	EMIFIL	BK1608LM182-T	1	230958R1
PCB U003	L1915	EMIFIL	BK1608LM182-T	1	230958R1
PCB U003	L1916	EMIFIL	BK1608LM182-T	1	230958R1

PCB U003	L1917	EMIFIL	BK1608LM182-T	1	230958R1	
PCB U003	L1918	EMIFIL	BK1608LM182-T	1	230958R1	
PCB U003	L1919	EMIFIL	BK1608LM182-T	1	230958R1	
PCB U003	L1920	EMIFIL	BK1608LM182-T	1	230958R1	
PCB U003	L1921	EMIFIL	BK1608LM182-T	1	230958R1	
PCB U003	L4000	COIL	0182-7310-470K-RB	1	231389	
PCB U003	L4001	CHOKE COIL	LBC2518T4R7M	1	231364M047R2	
PCB U003	L4005	CHOKE COIL	LBC2518T4R7M	1	231364M047R2	
PCB U003	L4700	CHOKE COIL	LBC2518T470M	1	231364M470R2	
PCB U003	L5	CHOKE COIL	LBC2518T100M	1	231364M100R2	
PCB U003	X1001	CERA LOCK	CSTCR5M00G53-B0	1	3010356R2	
PCB U003	X1002	CERA LOCK	CSTCE8M00G55-R0	1	3010416R2	
PCB U003	X101	CRYSTAL	HC-49S 4.332MHz	1	3010469T	<MMA>
PCB U003	X1301	CRYSTAL	HC-49US24.576MHz	1	3010423T	
PCB U003	<b>[CAPACITOR]</b>					
PCB U003	C1	UTSP C	CE04W50V-10M(UTSP)	1	397581007T	
PCB U003	C1001	C-CERA C	CK725F1A-105Z1	1	332181050R1	
PCB U003	C1004	C-CERA C	CK725F1A-105Z1	1	332181050R1	
PCB U003	C1005	C-CERA C	CK725F1E-104Z1	1	332161040R1	
PCB U003	C1006	C-CERA C	CK725F1E-104Z1	1	332161040R1	
PCB U003	C1007	C-CERA C	CK725F1A-105Z1	1	332181050R1	
PCB U003	C1008	C-CERA C	CC725CH1H-101J1	1	342101014R1	
PCB U003	C1009	C-CERA C	CC725CH1H-101J1	1	342101014R1	
PCB U003	C101	C-CERA C	CC725CH1H-221J1	1	342102214R1	<MMA>
PCB U003	C1010	C-CERA C	CC725CH1H-101J1	1	342101014R1	
PCB U003	C1015	UTSP C	CE04W25V-100M(UTSP)	1	397551017T	
PCB U003	C1017	UTSP C	CE04W10V-100M(UTSP)	1	397531017T	
PCB U003	C1019	UTSP C	CE04W10V-100M(UTSP)	1	397531017T	
PCB U003	C102	C-CERA C	CC725CH1H-331J1	1	342103314R1	<MMA>
PCB U003	C1020	C-CERA C	CK725F1A-105Z1	1	332181050R1	
PCB U003	C1021	C-CERA C	CK725B1H-102K1	1	332101025R1	
PCB U003	C1022	C-CERA C	CK725B1H-102K1	1	332101025R1	
PCB U003	C1023	ELECT C	CE04W25V-4.7M(MA)	1	355750479T	
PCB U003	C1024	C-CERA C	CK725B1H-102K1	1	332101025R1	
PCB U003	C1025	C-CERA C	CK725B1H-102K1	1	332101025R1	
PCB U003	C1026	C-CERA C	CK725B1H-102K1	1	332101025R1	
PCB U003	C1027	C-CERA C	CK725B1H-102K1	1	332101025R1	
PCB U003	C1028	UTSP C	CE04W50V-10M(UTSP)	1	397581007T	
PCB U003	C1029	UTSP C	CE04W10V-100M(UTSP)	1	397531017T	
PCB U003	C103	UTSP C	CE04W50V-10M(UTSP)	1	397581007T	<MMA>
PCB U003	C1030	C-CERA C	CK725F1E-104Z1	1	332161040R1	

PCB U003	C1031	C-CERA C	CK725F1E-104Z1	1	332161040R1	
PCB U003	C1032	C-CERA C	CK725F1E-104Z1	1	332161040R1	
PCB U003	C1033	C-CERA C	CK725F1E-104Z1	1	332161040R1	
PCB U003	C1034	C-CERA C	CK725F1E-104Z1	1	332161040R1	
PCB U003	C1036	C-CERA C	CK725F1E-104Z1	1	332161040R1	
PCB U003	C1037	C-CERA C	CK725F1E-104Z1	1	332161040R1	
PCB U003	C1038	UTSP C	CE04W50V-10M(UTSP)	1	397581007T	
PCB U003	C1039	C-CERA C	CK725F1E-104Z1	1	332161040R1	
PCB U003	C104	UTSP C	CE04W50V-10M(UTSP)	1	397581007T	<MMA>
PCB U003	C1040	UTSP C	CE04W10V-470M(UTSP)	1	397534717T	
PCB U003	C1041	ELECT C	CE04W16V-10M	1	355741009T	
PCB U003	C1042	C-CERA C	CK725F1E-104Z1	1	332161040R1	
PCB U003	C1043	C-CERA C	CK725F1A-105Z1	1	332181050R1	
PCB U003	C1044	C-CERA C	CK725F1A-105Z1	1	332181050R1	
PCB U003	C1045	C-CERA C	CK725F1A-105Z1	1	332181050R1	
PCB U003	C1046	C-CERA C	CK725F1A-105Z1	1	332181050R1	
PCB U003	C1047	C-CERA C	CK725F1A-105Z1	1	332181050R1	
PCB U003	C1048	C-CERA C	CK725F1A-105Z1	1	332181050R1	
PCB U003	C105	C-CERA C	CK725B1H-103K1	1	332101035R1	<MMA>
PCB U003	C1053	C-CERA C	CK725B1H-102K1	1	332101025R1	
PCB U003	C1054	UTSP C	CE04W10V-220M(UTSP)	1	397532217T	
PCB U003	C106	C-CERA C	CC725CH1H-331J1	1	342103314R1	<MMA>
PCB U003	C1060	C-CERA C	CK725B1H-102K1	1	332101025R1	
PCB U003	C1061	C-CERA C	CK725B1H-102K1	1	332101025R1	
PCB U003	C107	C-CERA C	CK725F1E-104Z1	1	332161040R1	<MMA>
PCB U003	C108	C-CERA C	CC725CH1H-150J1	1	342101504R1	<MMA>
PCB U003	C109	C-CERA C	CC725CH1H-150J1	1	342101504R1	<MMA>
PCB U003	C110	C-CERA C	CK725F1A-105Z1	1	332181050R1	<MMA>
PCB U003	C1101	UTSP C	CE04W10V-470M(UTSP)	1	397534717T	
PCB U003	C1104	C-CERA C	CK725F1E-104Z1	1	332161040R1	
PCB U003	C1290	UTSP C	CE04W25V-100M(UTSP)	1	397551017T	
PCB U003	C1291	C-CERA C	CK725F1E-104Z1	1	332161040R1	
PCB U003	C1292	UTSP C	CE04W50V-10M(UTSP)	1	397581007T	
PCB U003	C1293	UTSP C	CE04W50V-10M(UTSP)	1	397581007T	
PCB U003	C1294	UTSP C	CE04W50V-22M(UTSP)	1	397582207T	
PCB U003	C1295	UTSP C	CE04W50V-22M(UTSP)	1	397582207T	
PCB U003	C1296	UTSP C	CE04W50V-22M(UTSP)	1	397582207T	
PCB U003	C1302	UTSP C	CE04W10V-100M(UTSP)	1	397531017T	
PCB U003	C1303	UTSP C	CE04W50V 47M(UTSP)	1	397584707T	
PCB U003	C1304	C-CERA C	CK725F1E-104Z1	1	332161040R1	
PCB U003	C1305	UTSP C	CE04W10V-470M(UTSP)	1	397534717T	

PCB U003	C1306	C-CERA C	CK725F1E-104Z1	1	332161040R1
PCB U003	C1307	UTSP C	CE04W50V-10M(UTSP)	1	397581007T
PCB U003	C1308	C-CERA C	CK725F1E-104Z1	1	332161040R1
PCB U003	C1309	C-CERA C	CK725F1E-104Z1	1	332161040R1
PCB U003	C1310	UTSP C	CE04W10V-470M(UTSP)	1	397534717T
PCB U003	C1311	C-CERA C	CK725F1E-104Z1	1	332161040R1
PCB U003	C1365	C-CERA C	CK725B1C-104K1	1	332121045R1
PCB U003	C1366	C-CERA C	CC725CH1H-101J1	1	342101014R1
PCB U003	C1368	C-CERA C	CC725CH1H-101J1	1	342101014R1
PCB U003	C1369	UTSP C	CE04W10V-100M(UTSP)	1	397531017T
PCB U003	C1370	UTSP C	CE04W10V-470M(UTSP)	1	397534717T
PCB U003	C1371	C-CERA C	CK725F1E-104Z1	1	332161040R1
PCB U003	C1372	C-CERA C	CK725F1E-104Z1	1	332161040R1
PCB U003	C1373	C-CERA C	CK725F1E-104Z1	1	332161040R1
PCB U003	C1374	UTSP C	CE04W10V-470M(UTSP)	1	397534717T
PCB U003	C1375	C-CERA C	CK725B1C-104K1	1	332121045R1
PCB U003	C1376	UTSP C	CE04W10V-100M(UTSP)	1	397531017T
PCB U003	C1377	UTSJ C	CE04W50V-47M(UTSJ)	1	398084707T
PCB U003	C1379	C-CERA C	CK725F1E-104Z1	1	332161040R1
PCB U003	C1380	C-CERA C	CK725B1C-104K1	1	332121045R1
PCB U003	C1381	C-CERA C	CC725CH1H-101J1	1	342101014R1
PCB U003	C1388	C-CERA C	CK725B1H-102K1	1	332101025R1
PCB U003	C1390	C-CERA C	CK725B1H-223K1	1	332102235R1
PCB U003	C1392	C-CERA C	CK725F1E-104Z1	1	332161040R1
PCB U003	C1396	C-CERA C	CK725F1E-104Z1	1	332161040R1
PCB U003	C1397	C-CERA C	CK725B1H-102K1	1	332101025R1
PCB U003	C1398	C-CERA C	CK725F1E-104Z1	1	332161040R1
PCB U003	C1399	UTSP C	CE04W10V-470M(UTSP)	1	397534717T
PCB U003	C1400	C-CERA C	CK725F1E-104Z1	1	332161040R1
PCB U003	C1401	C-CERA C	CC725CH1H-330J1	1	342103304R1
PCB U003	C1402	C-CERA C	CC725CH1H-330J1	1	342103304R1
PCB U003	C1403	C-CERA C	CC725CH1H-330J1	1	342103304R1
PCB U003	C1404	C-CERA C	CC725CH1H-330J1	1	342103304R1
PCB U003	C1405	C-CERA C	CC725CH1H-330J1	1	342103304R1
PCB U003	C1406	C-CERA C	CC725CH1H-330J1	1	342103304R1
PCB U003	C1408	C-CERA C	CC725CH1H-080D1	1	342100802R1
PCB U003	C1409	C-CERA C	CC725CH1H-080D1	1	342100802R1
PCB U003	C1410	UTSP C	CE04W10V-470M(UTSP)	1	397534717T
PCB U003	C1411	UTSP C	CE04W10V-470M(UTSP)	1	397534717T
PCB U003	C1413	C-CERA C	CK725F1E-104Z1	1	332161040R1
PCB U003	C1414	C-CERA C	CK725F1E-104Z1	1	332161040R1

PCB U003	C1415	C-CERA C	CK725F1E-104Z1	1	332161040R1
PCB U003	C1417	C-CERA C	CK725F1E-104Z1	1	332161040R1
PCB U003	C1418	C-CERA C	CK725F1E-104Z1	1	332161040R1
PCB U003	C1419	C-CERA C	CC725CH1H-080D1	1	342100802R1
PCB U003	C1421	UTSP C	CE04W10V-220M(UTSP)	1	397532217T
PCB U003	C1424	C-CERA C	CC725CH1H-060D1	1	342100602R1
PCB U003	C1425	C-CERA C	CC725CH1H-060D1	1	342100602R1
PCB U003	C1430	UTSP C	CE04W10V-470M(UTSP)	1	397534717T
PCB U003	C1454	C-FILM C	ECHU16V-104J	1	373041044R2
PCB U003	C1455	C-FILM C	ECHU16V-104J	1	373041044R2
PCB U003	C1456	C-FILM C	ECHU16V-104J	1	373041044R2
PCB U003	C1460	UTSJ C	CE04W50V-47M(UTSJ)	1	398084707T
PCB U003	C1499	UTSP C	CE04W10V-100M(UTSP)	1	397531017T
PCB U003	C1582	C-FILM C	ECHU50V-222J	1	373022224R2
PCB U003	C1583	C-FILM C	ECHU50V-222J	1	373022224R2
PCB U003	C1600	UPZ C	2AUPZTF471JE	1	376334714T
PCB U003	C1601	UPZ C	2AUPZTF471JE	1	376334714T
PCB U003	C1602	UPZ C	2AUPZTF471JE	1	376334714T
PCB U003	C1603	UPZ C	2AUPZTF471JE	1	376334714T
PCB U003	C1604	UPZ C	2AUPZTF471JE	1	376334714T
PCB U003	C1605	UPZ C	2AUPZTF471JE	1	376334714T
PCB U003	C1606	UPZ C	2AUPZTF471JE	1	376334714T
PCB U003	C1607	UPZ C	2AUPZTF471JE	1	376334714T
PCB U003	C1610	CERA C	CC45SL50V-101J	1	345021014T
PCB U003	C1611	CERA C	CC45SL50V-101J	1	345021014T
PCB U003	C1612	CERA C	CC45SL50V-101J	1	345021014T
PCB U003	C1613	CERA C	CC45SL50V-101J	1	345021014T
PCB U003	C1614	CERA C	CC45SL50V-101J	1	345021014T
PCB U003	C1615	CERA C	CC45SL50V-101J	1	345021014T
PCB U003	C1616	CERA C	CC45SL50V-101J	1	345021014T
PCB U003	C1617	CERA C	CC45SL50V-101J	1	345021014T
PCB U003	C1620	CERA C	CC45SL50V-101J	1	345021014T
PCB U003	C1621	CERA C	CC45SL50V-101J	1	345021014T
PCB U003	C1622	CERA C	CC45SL50V-101J	1	345021014T
PCB U003	C1623	CERA C	CC45SL50V-101J	1	345021014T
PCB U003	C1624	CERA C	CC45SL50V-101J	1	345021014T
PCB U003	C1625	CERA C	CC45SL50V-101J	1	345021014T
PCB U003	C1626	CERA C	CC45SL50V-101J	1	345021014T
PCB U003	C1627	CERA C	CC45SL50V-101J	1	345021014T
PCB U003	C1650	UTSP C	CE04W25V-220M(UTSP)	1	397552217T
PCB U003	C1651	UTSP C	CE04W25V-220M(UTSP)	1	397552217T



PCB U003	C1800	UTSP C	CE04W25V-47M(UTSP)	1	397554707T
PCB U003	C1801	UTSP C	CE04W25V-47M(UTSP)	1	397554707T
PCB U003	C1810	UTSP C	CE04W25V-47M(UTSP)	1	397554707T
PCB U003	C1811	UTSP C	CE04W25V-47M(UTSP)	1	397554707T
PCB U003	C1900	UTSP C	CE04W25V-100M(UTSP)	1	397551017T
PCB U003	C1902	UTSP C	CE04W25V-100M(UTSP)	1	397551017T
PCB U003	C1904	UTSP C	CE04W50V-10M(UTSP)	1	397581007T
PCB U003	C1905	UTSP C	CE04W50V-10M(UTSP)	1	397581007T
PCB U003	C1906	C-CERA C	CC725CH1H-101J1	1	342101014R1
PCB U003	C1907	C-CERA C	CC725CH1H-101J1	1	342101014R1
PCB U003	C1908	UTSP C	CE04W50V-10M(UTSP)	1	397581007T
PCB U003	C1909	UTSP C	CE04W50V-10M(UTSP)	1	397581007T
PCB U003	C1911	C-CERA C	CC725CH1H-101J1	1	342101014R1
PCB U003	C1912	C-CERA C	CC725CH1H-101J1	1	342101014R1
PCB U003	C1913	C-CERA C	CC725CH1H-470J1	1	342104704R1
PCB U003	C1914	C-CERA C	CK725F1E-104Z1	1	332161040R1
PCB U003	C1915	C-CERA C	CK725F1E-104Z1	1	332161040R1
PCB U003	C1921	C-CERA C	CC725CH1H-471J1	1	342104714R1
PCB U003	C1922	C-CERA C	CC725CH1H-471J1	1	342104714R1
PCB U003	C1923	C-CERA C	CC725CH1H-221J1	1	342102214R1
PCB U003	C1924	C-CERA C	CC725CH1H-221J1	1	342102214R1
PCB U003	C1930	C-CERA C	CK725F1E-104Z1	1	332161040R1
PCB U003	C1931	C-CERA C	CC725CH1H-470J1	1	342104704R1
PCB U003	C1941	UTSP C	CE04W25V-100M(UTSP)	1	397551017T
PCB U003	C1942	C-CERA C	CK725F1E-104Z1	1	332161040R1
PCB U003	C1943	C-CERA C	CK725F1E-104Z1	1	332161040R1
PCB U003	C1944	UTSP C	CE04W25V-47M(UTSP)	1	397554707T
PCB U003	C1951	VR C	CE04W6.3V-470M(VR)	1	394624717T
PCB U003	C1952	VR C	CE04W6.3V-470M(VR)	1	394624717T
PCB U003	C1953	UTSP C	CE04W50V-10M(UTSP)	1	397581007T
PCB U003	C1954	UTSP C	CE04W10V-100M(UTSP)	1	397531017T
PCB U003	C1955	C-CERA C	CK725F1E-104Z1	1	332161040R1
PCB U003	C1956	C-CERA C	CC725CH1H-470J1	1	342104704R1
PCB U003	C1957	C-CERA C	CC725CH1H-470J1	1	342104704R1
PCB U003	C1961	VR C	CE04W6.3V-470M(VR)	1	394624717T
PCB U003	C1962	VR C	CE04W6.3V-470M(VR)	1	394624717T
PCB U003	C1963	UTSP C	CE04W50V-10M(UTSP)	1	397581007T
PCB U003	C1964	UTSP C	CE04W10V-100M(UTSP)	1	397531017T
PCB U003	C1965	C-CERA C	CK725F1E-104Z1	1	332161040R1
PCB U003	C1966	C-CERA C	CC725CH1H-470J1	1	342104704R1
PCB U003	C1967	C-CERA C	CC725CH1H-470J1	1	342104704R1

PCB U003	C1971	VR C	CE04W6.3V-470M(VR)	1	394624717T
PCB U003	C1972	VR C	CE04W6.3V-470M(VR)	1	394624717T
PCB U003	C1973	UTSP C	CE04W50V-10M(UTSP)	1	397581007T
PCB U003	C1974	UTSP C	CE04W10V-100M(UTSP)	1	397531017T
PCB U003	C1975	C-CERA C	CK725F1E-104Z1	1	332161040R1
PCB U003	C1976	C-CERA C	CK725B1H-102K1	1	332101025R1
PCB U003	C1977	C-CERA C	CC725CH1H-470J1	1	342104704R1
PCB U003	C1978	C-CERA C	CK725B1H-102K1	1	332101025R1
PCB U003	C1979	C-CERA C	CK725B1H-102K1	1	332101025R1
PCB U003	C1980	C-CERA C	CC725CH1H-470J1	1	342104704R1
PCB U003	C1981	C-CERA C	CC725CH1H-470J1	1	342104704R1
PCB U003	C2	VR C	CE04W16V-100M(VR)	1	394641017T
PCB U003	C4000	UTSP C	CE04W50V-4.7M(UTSP)	1	397580477T
PCB U003	C4001	VR C	CE04W16V-470M(VR)	1	394644717T
PCB U003	C4002	UTSP C	CE04W10V-470M(UTSP)	1	397534717T
PCB U003	C4003	TF C	ECQ-V50V-334J	1	374723344T
PCB U003	C4004	UTSP C	CE04W10V-470M(UTSP)	1	397534717T
PCB U003	C4005	C-CERA C	CK725B1H-223K1	1	332102235R1
PCB U003	C4006	C-CERA C	CK725F1E-104Z1	1	332161040R1
PCB U003	C4007	ELECT C	CE04W35V-4700M(VZ)	1	394564727S
PCB U003	C4009	TF C	ECQ-V50V-334J	1	374723344T
PCB U003	C4010	TF C	ECQ-V50V-334J	1	374723344T
PCB U003	C4012	TF C	ECQ-V50V-334J	1	374723344T
PCB U003	C4013	ELECT C	CE04W35V-4700M(VZ)	1	394564727S
PCB U003	C4100	UTSP C	CE04W50V-10M(UTSP)	1	397581007T
PCB U003	C4101	UTSP C	CE04W50V-10M(UTSP)	1	397581007T
PCB U003	C4102	UTSP C	CE04W50V-10M(UTSP)	1	397581007T
PCB U003	C4103	UTSP C	CE04W50V-2.2M(UTSP)	1	397580227T
PCB U003	C4108	UTSP C	CE04W50V-1M(UTSP)	1	397580107T
PCB U003	C4109	UTSP C	CE04W50V-1M(UTSP)	1	397580107T
PCB U003	C4110	UTSP C	CE04W50V-2.2M(UTSP)	1	397580227T
PCB U003	C4111	C-CERA C	CK725F1E-104Z1	1	332161040R1
PCB U003	C4112	C-CERA C	CK725B1H-102K1	1	332101025R1
PCB U003	C4114	UTSP C	CE04W50V-1M(UTSP)	1	397580107T
PCB U003	C4115	VR C	CE04W6.3V-470M(VR)	1	394624717T
PCB U003	C4119	VR C	CE04W6.3V-470M(VR)	1	394624717T
PCB U003	C4120	VR C	CE04W6.3V-470M(VR)	1	394624717T
PCB U003	C4121	C-CERA C	CK725F1E-104Z1	1	332161040R1
PCB U003	C4122	UTSP C	CE04W50V-1M(UTSP)	1	397580107T
PCB U003	C4123	UTSP C	CE04W50V-2.2M(UTSP)	1	397580227T
PCB U003	C4127	VR C	CE04W6.3V-470M(VR)	1	394624717T

PCB U003	C4130	VR C	CE04W6.3V-470M(VR)	1	394624717T
PCB U003	C4131	C-CERA C	CK725B1H-102K1	1	332101025R1
PCB U003	C4132	VR C	CE04W6.3V-470M(VR)	1	394624717T
PCB U003	C4133	UTSP C	CE04W50V-1M(UTSP)	1	397580107T
PCB U003	C4134	C-CERA C	CK725F1E-104Z1	1	332161040R1
PCB U003	C4135	UTSP C	CE04W25V-47M(UTSP)	1	397554707T
PCB U003	C4136	C-CERA C	CK725B1H-102K1	1	332101025R1
PCB U003	C4137	C-CERA C	CK725B0J-106K	1	332091065R2
PCB U003	C4138	VR C	CE04W6.3V-470M(VR)	1	394624717T
PCB U003	C4139	UTSP C	CE04W50V-22M(UTSP)	1	397582207T
PCB U003	C4140	C-CERA C	CK725F1E-104Z1	1	332161040R1
PCB U003	C4141	UTSP C	CE04W50V-1M(UTSP)	1	397580107T
PCB U003	C4142	VR C	CE04W6.3V-470M(VR)	1	394624717T
PCB U003	C4143	VR C	CE04W6.3V-470M(VR)	1	394624717T
PCB U003	C4144	C-CERA C	CK725F1E-104Z1	1	332161040R1
PCB U003	C4145	UTSP C	CE04W50V-2.2M(UTSP)	1	397580227T
PCB U003	C4146	VR C	CE04W6.3V-470M(VR)	1	394624717T
PCB U003	C4150	VR C	CE04W6.3V-470M(VR)	1	394624717T
PCB U003	C4151	UTSP C	CE04W25V-47M(UTSP)	1	397554707T
PCB U003	C4152	UTSP C	CE04W25V-47M(UTSP)	1	397554707T
PCB U003	C4154	C-CERA C	CK725F1E-104Z1	1	332161040R1
PCB U003	C4156	UTSP C	CE04W25V-47M(UTSP)	1	397554707T
PCB U003	C4157	VR C	CE04W6.3V-470M(VR)	1	394624717T
PCB U003	C4159	C-CERA C	CK725B1H-102K1	1	332101025R1
PCB U003	C4160	VR C	CE04W6.3V-470M(VR)	1	394624717T
PCB U003	C4161	C-CERA C	CK725F1E-104Z1	1	332161040R1
PCB U003	C4162	C-CERA C	CK725F1E-104Z1	1	332161040R1
PCB U003	C4163	VR C	CE04W6.3V-470M(VR)	1	394624717T
PCB U003	C4167	C-CERA C	CK725F1A-105Z1	1	332181050R1
PCB U003	C4168	UTSP C	CE04W50V-1M(UTSP)	1	397580107T
PCB U003	C4169	UTSP C	CE04W50V-2.2M(UTSP)	1	397580227T
PCB U003	C4173	VR C	CE04W6.3V-470M(VR)	1	394624717T
PCB U003	C4174	C-CERA C	CK725B1H-102K1	1	332101025R1
PCB U003	C4175	C-CERA C	CK725F1A-105Z1	1	332181050R1
PCB U003	C4176	UTSP C	CE04W50V-1M(UTSP)	1	397580107T
PCB U003	C4179	UTSP C	CE04W50V-2.2M(UTSP)	1	397580227T
PCB U003	C4183	C-CERA C	CK725F1E-104Z1	1	332161040R1
PCB U003	C4184	UTSP C	CE04W25V-47M(UTSP)	1	397554707T
PCB U003	C4186	UTSP C	CE04W25V-47M(UTSP)	1	397554707T
PCB U003	C4187	UTSP C	CE04W25V-47M(UTSP)	1	397554707T
PCB U003	C4192	UTSP C	CE04W50V-1M(UTSP)	1	397580107T

PCB U003	C4193	C-CERA C	CC725CH1H-151J1	1	342101514R1
PCB U003	C4194	C-CERA C	CC725CH1H-151J1	1	342101514R1
PCB U003	C4195	C-CERA C	CC725CH1H-151J1	1	342101514R1
PCB U003	C4196	C-CERA C	CK725B1H-102K1	1	332101025R1
PCB U003	C4197	C-CERA C	CK725F1A-105Z1	1	332181050R1
PCB U003	C4198	UTSP C	CE04W50V-1M(UTSP)	1	397580107T
PCB U003	C4199	UTSP C	CE04W50V-2.2M(UTSP)	1	397580227T
PCB U003	C4200	UTSP C	CE04W50V-1M(UTSP)	1	397580107T
PCB U003	C4202	C-CERA C	CK725F1A-105Z1	1	332181050R1
PCB U003	C4203	UTSP C	CE04W25V-47M(UTSP)	1	397554707T
PCB U003	C4205	UTSP C	CE04W50V-1M(UTSP)	1	397580107T
PCB U003	C4206	UTSP C	CE04W50V-2.2M(UTSP)	1	397580227T
PCB U003	C4207	UTSP C	CE04W50V-1M(UTSP)	1	397580107T
PCB U003	C4209	C-CERA C	CK725B1H-102K1	1	332101025R1
PCB U003	C4211	VR C	CE04W6.3V-470M(VR)	1	394624717T
PCB U003	C4212	C-CERA C	CC725CH1H-151J1	1	342101514R1
PCB U003	C4213	C-CERA C	CC725CH1H-151J1	1	342101514R1
PCB U003	C4214	C-CERA C	CC725CH1H-151J1	1	342101514R1
PCB U003	C4215	UTSP C	CE04W25V-47M(UTSP)	1	397554707T
PCB U003	C4218	C-CERA C	CK725F1E-104Z1	1	332161040R1
PCB U003	C4219	C-CERA C	CK725F1E-104Z1	1	332161040R1
PCB U003	C4226	VR C	CE04W6.3V-470M(VR)	1	394624717T
PCB U003	C4234	VR C	CE04W6.3V-470M(VR)	1	394624717T
PCB U003	C4235	VR C	CE04W6.3V-470M(VR)	1	394624717T
PCB U003	C4236	UTSP C	CE04W50V-2.2M(UTSP)	1	397580227T
PCB U003	C4237	UTSP C	CE04W50V-1M(UTSP)	1	397580107T
PCB U003	C4238	UTSP C	CE04W50V-1M(UTSP)	1	397580107T
PCB U003	C4239	UTSP C	CE04W50V-1M(UTSP)	1	397580107T
PCB U003	C4240	UTSP C	CE04W50V-1M(UTSP)	1	397580107T
PCB U003	C4241	UTSP C	CE04W50V-2.2M(UTSP)	1	397580227T
PCB U003	C4253	C-CERA C	CK725F1E-104Z1	1	332161040R1
PCB U003	C4254	C-CERA C	CK725F1E-104Z1	1	332161040R1
PCB U003	C4255	C-CERA C	CK725F1E-104Z1	1	332161040R1
PCB U003	C4294	C-CERA C	CC725CH1H-151J1	1	342101514R1
PCB U003	C4295	C-CERA C	CK725B1H-102K1	1	332101025R1
PCB U003	C4500	UTSP C	CE04W25V-220M(UTSP)	1	397552217T
PCB U003	C4501	UTSP C	CE04W25V-220M(UTSP)	1	397552217T
PCB U003	C4502	UTSP C	CE04W25V-220M(UTSP)	1	397552217T
PCB U003	C4503	UTSP C	CE04W25V-220M(UTSP)	1	397552217T
PCB U003	C47	ELECT C	CE04W35V-10M(S)	1	353761009T
PCB U003	C4700	UTSP C	CE04W50V-1M(UTSP)	1	397580107T

PCB U003	C4701	UTSP C	CE04W50V-1M(UTSP)	1	397580107T	
PCB U003	C4702	VR C	CE04W16V-100M(VR)	1	394641017T	
PCB U003	C4703	C-CERA C	CK725F1E-104Z1	1	332161040R1	
PCB U003	C4704	UTSP C	CE04W50V-1M(UTSP)	1	397580107T	
PCB U003	C4705	UTSP C	CE04W50V-1M(UTSP)	1	397580107T	
PCB U003	C4706	C-CERA C	CK725B1H-102K1	1	332101025R1	
PCB U003	C48	ELECT C	CE04W35V-10M(S)	1	353761009T	
PCB U003	C52	UTSP C	CE04W50V-10M(UTSP)	1	397581007T	<MDD>
PCB U003	C53	UTSP C	CE04W50V-10M(UTSP)	1	397581007T	<MDD>
PCB U003	C7	UTSP C	CE04W25V-47M(UTSP)	1	397554707T	
PCB U003	<b>[RESISTOR]</b>					
PCB U003	R1001	C-CARBON R	RN72K1J-473JE	1	435034734R1	
PCB U003	R1002	C-CARBON R	RN72K1J-222JE	1	435032224R1	
PCB U003	R1003	C-CARBON R	RN72K1J-222JE	1	435032224R1	
PCB U003	R1004	C-CARBON R	RN72K1J-102JE	1	435031024R1	
PCB U003	R1005	C-CARBON R	RN72K1J-102JE	1	435031024R1	
PCB U003	R1006	C-CARBON R	RN72K1J-473JE	1	435034734R1	
PCB U003	R1007	C-CARBON R	RN72K1J-222JE	1	435032224R1	
PCB U003	R1008	C-CARBON R	RN72K1J-101JE	1	435031014R1	
PCB U003	R1010	C-CARBON R	RN72K1J-103JE	1	435031034R1	
PCB U003	R1011	C-CARBON R	RN72K1J-102JE	1	435031024R1	
PCB U003	R1012	C-CARBON R	RN72K1J-470JE	1	435034704R1	
PCB U003	R1013	C-CARBON R	RN72K1J-470JE	1	435034704R1	
PCB U003	R1014	C-CARBON R	RN72K1J-470JE	1	435034704R1	
PCB U003	R1015	C-CARBON R	RN72K1J-470JE	1	435034704R1	
PCB U003	R1016	C-CARBON R	RN72K1J-222JE	1	435032224R1	
PCB U003	R1017	C-CARBON R	RN72K1J-102JE	1	435031024R1	
PCB U003	R1019	C-CARBON R	RN72K1J-470JE	1	435034704R1	
PCB U003	R1020	C-CARBON R	RN72K1J-472JE	1	435034724R1	
PCB U003	R1026	C-CARBON R	RN72K1J-224JE	1	435032244R1	
PCB U003	R1027	C-CARBON R	RN72K1J-473JE	1	435034734R1	
PCB U003	R1028	C-CARBON R	RN72K1J-470JE	1	435034704R1	
PCB U003	R1029	C-CARBON R	RN72K1J-470JE	1	435034704R1	
PCB U003	R1031	C-CARBON R	RN72K1J-221JE	1	435032214R1	
PCB U003	R1032	C-CARBON R	RN72K1J-221JE	1	435032214R1	
PCB U003	R1033	C-CARBON R	RN72K1J-221JE	1	435032214R1	
PCB U003	R1034	C-CARBON R	RN72K1J-000JE	1	435030004R1	
PCB U003	R1035	C-CARBON R	RN72K1J-103JE	1	435031034R1	
PCB U003	R1036	C-CARBON R	RN72K1J-222JE	1	435032224R1	
PCB U003	R1037	C-CARBON R	RN72K1J-473JE	1	435034734R1	
PCB U003	R1038	C-CARBON R	RN72K1J-473JE	1	435034734R1	

PCB U003	R1039	C-CARBON R	RN72K1J-473JE	1	435034734R1
PCB U003	R1040	C-CARBON R	RN72K1J-473JE	1	435034734R1
PCB U003	R1041	C-CARBON R	RN72K1J-103JE	1	435031034R1
PCB U003	R1042	C-CARBON R	RN72K1J-473JE	1	435034734R1
PCB U003	R1043	C-CARBON R	RN72K1J-473JE	1	435034734R1
PCB U003	R1044	C-CARBON R	RN72K1J-470JE	1	435034704R1
PCB U003	R1045	C-CARBON R	RN72K1J-470JE	1	435034704R1
PCB U003	R1046	C-CARBON R	RN72K1J-222JE	1	435032224R1
PCB U003	R1047	C-CARBON R	RN72K1J-102JE	1	435031024R1
PCB U003	R1048	C-CARBON R	RN72K1J-473JE	1	435034734R1
PCB U003	R1049	C-CARBON R	RN72K1J-470JE	1	435034704R1
PCB U003	R1050	C-CARBON R	RN72K1J-470JE	1	435034704R1
PCB U003	R1051	C-CARBON R	RN72K1J-473JE	1	435034734R1
PCB U003	R1052	C-CARBON R	RN72K1J-473JE	1	435034734R1
PCB U003	R1055	C-CARBON R	RN72K1J-273JE	1	435032734R1
PCB U003	R1056	C-CARBON R	RN72K1J-273JE	1	435032734R1
PCB U003	R1057	C-CARBON R	RN72K1J-470JE	1	435034704R1
PCB U003	R1058	C-CARBON R	RN72K1J-103JE	1	435031034R1
PCB U003	R1059	C-CARBON R	RN72K1J-103JE	1	435031034R1
PCB U003	R1060	C-CARBON R	RN72K1J-470JE	1	435034704R1
PCB U003	R1061	C-CARBON R	RN72K1J-103JE	1	435031034R1
PCB U003	R1062	C-CARBON R	RN72K1J-470JE	1	435034704R1
PCB U003	R1063	C-CARBON R	RN72K1J-470JE	1	435034704R1
PCB U003	R1064	C-CARBON R	RN72K1J-222JE	1	435032224R1
PCB U003	R1065	C-CARBON R	RN72K1J-221JE	1	435032214R1
PCB U003	R1066	C-CARBON R	RN72K1J-470JE	1	435034704R1
PCB U003	R1067	C-CARBON R	RN72K1J-224JE	1	435032244R1
PCB U003	R1068	C-CARBON R	RN72K1J-273JE	1	435032734R1
PCB U003	R1069	C-CARBON R	RN72K1J-101JE	1	435031014R1
PCB U003	R1070	C-CARBON R	RN72K1J-103JE	1	435031034R1
PCB U003	R1071	C-CARBON R	RN72K1J-473JE	1	435034734R1
PCB U003	R1072	C-CARBON R	RN72K1J-473JE	1	435034734R1
PCB U003	R1073	C-CARBON R	RN72K1J-473JE	1	435034734R1
PCB U003	R1074	C-CARBON R	RN72K1J-473JE	1	435034734R1
PCB U003	R1075	C-CARBON R	RN72K1J-102JE	1	435031024R1
PCB U003	R1077	C-CARBON R	RN72K1J-470JE	1	435034704R1
PCB U003	R1078	C-CARBON R	RN72K1J-221JE	1	435032214R1
PCB U003	R1079	C-CARBON R	RN72K1J-103JE	1	435031034R1
PCB U003	R1080	C-CARBON R	RN72K1J-103JE	1	435031034R1
PCB U003	R1081	C-CARBON R	RN72K1J-272JE	1	435032724R1
PCB U003	R1082	C-CARBON R	RN72K1J-272JE	1	435032724R1

PCB U003	R1083	C-CARBON R	RN72K1J-221JE	1	435032214R1	
PCB U003	R1084	C-CARBON R	RN72K1J-272JE	1	435032724R1	
PCB U003	R1085	C-CARBON R	RN72K1J-221JE	1	435032214R1	
PCB U003	R1086	C-CARBON R	RN72K1J-221JE	1	435032214R1	
PCB U003	R1087	C-CARBON R	RN72K1J-221JE	1	435032214R1	
PCB U003	R1088	C-CARBON R	RN72K1J-470JE	1	435034704R1	
PCB U003	R1089	C-CARBON R	RN72K1J-221JE	1	435032214R1	
PCB U003	R1090	C-CARBON R	RN72K1J-470JE	1	435034704R1	
PCB U003	R1091	C-CARBON R	RN72K1J-221JE	1	435032214R1	
PCB U003	R1092	C-CARBON R	RN72K1J-221JE	1	435032214R1	
PCB U003	R1093	C-CARBON R	RN72K1J-473JE	1	435034734R1	
PCB U003	R1094	C-CARBON R	RN72K1J-221JE	1	435032214R1	
PCB U003	R1095	C-CARBON R	RN72K1J-221JE	1	435032214R1	
PCB U003	R1096	C-CARBON R	RN72K1J-470JE	1	435034704R1	
PCB U003	R1097	C-CARBON R	RN72K1J-472JE	1	435034724R1	
PCB U003	R1098	C-CARBON R	RN72K1J-470JE	1	435034704R1	
PCB U003	R1099	C-CARBON R	RN72K1J-103JE	1	435031034R1	
PCB U003	R11	METAL O R	RS1/2WBJ-10	1	443521004T	
PCB U003	R1101	C-CARBON R	RN72K1J-221JE	1	435032214R1	
PCB U003	R1104	C-CARBON R	RN72K1J-221JE	1	435032214R1	
PCB U003	R1107	C-CARBON R	RN72K1J-470JE	1	435034704R1	
PCB U003	R1109	C-CARBON R	RN72K1J-470JE	1	435034704R1	
PCB U003	R1111	C-CARBON R	RN72K1J-221JE	1	435032214R1	
PCB U003	R1113	C-CARBON R	RN72K1J-221JE	1	435032214R1	
PCB U003	R1114	C-CARBON R	RN72K1J-470JE	1	435034704R1	<MDD>
PCB U003	R1115	C-CARBON R	RN72K1J-221JE	1	435032214R1	
PCB U003	R1116	C-CARBON R	RN72K1J-470JE	1	435034704R1	<MDD>
PCB U003	R1117	C-CARBON R	RN72K1J-221JE	1	435032214R1	
PCB U003	R1118	C-CARBON R	RN72K1J-470JE	1	435034704R1	<MDD>
PCB U003	R1119	C-CARBON R	RN72K1J-221JE	1	435032214R1	
PCB U003	R1120	C-CARBON R	RN72K1J-470JE	1	435034704R1	
PCB U003	R1121	C-CARBON R	RN72K1J-221JE	1	435032214R1	
PCB U003	R1122	C-CARBON R	RN72K1J-470JE	1	435034704R1	
PCB U003	R1123	C-CARBON R	RN72K1J-473JE	1	435034734R1	
PCB U003	R1124	C-CARBON R	RN72K1J-221JE	1	435032214R1	
PCB U003	R1126	C-CARBON R	RN72K1J-221JE	1	435032214R1	
PCB U003	R1128	C-CARBON R	RN72K1J-470JE	1	435034704R1	
PCB U003	R1130	C-CARBON R	RN72K1J-221JE	1	435032214R1	
PCB U003	R1131	C-CARBON R	RN72K1J-221JE	1	435032214R1	
PCB U003	R1132	C-CARBON R	RN72K1J-470JE	1	435034704R1	
PCB U003	R1133	C-CARBON R	RN72K1J-221JE	1	435032214R1	

PCB U003	R1134	C-CARBON R	RN72K1J-470JE	1	435034704R1	
PCB U003	R1136	C-CARBON R	RN72K1J-102JE	1	435031024R1	
PCB U003	R1137	C-CARBON R	RN72K1J-470JE	1	435034704R1	
PCB U003	R1138	C-CARBON R	RN72K1J-102JE	1	435031024R1	
PCB U003	R1139	C-CARBON R	RN72K1J-221JE	1	435032214R1	
PCB U003	R1140	C-CARBON R	RN72K1J-221JE	1	435032214R1	
PCB U003	R1141	C-CARBON R	RN72K1J-470JE	1	435034704R1	
PCB U003	R1142	C-CARBON R	RN72K1J-473JE	1	435034734R1	
PCB U003	R1143	C-CARBON R	RN72K1J-470JE	1	435034704R1	
PCB U003	R1144	C-CARBON R	RN72K1J-221JE	1	435032214R1	
PCB U003	R1146	METAL R	RNU1WCJ-1.5	1	453630154T	
PCB U003	R1147	METAL R	RNU1WCJ-1.5	1	453630154T	
PCB U003	R1148	C-CARBON R	RN72K1J-221JE	1	435032214R1	
PCB U003	R1149	C-CARBON R	RN72K1J-470JE	1	435034704R1	
PCB U003	R1150	C-CARBON R	RN72K1J-103JE	1	435031034R1	
PCB U003	R1151	C-CARBON R	RN72K1J-103JE	1	435031034R1	
PCB U003	R1152	C-CARBON R	RN72K1J-103JE	1	435031034R1	
PCB U003	R1153	C-CARBON R	RN72K1J-470JE	1	435034704R1	
PCB U003	R1154	C-CARBON R	RN72K1J-333JE	1	435033334R1	
PCB U003	R1155	C-CARBON R	RN72K1J-563JE	1	435035634R1	
PCB U003	R1156	C-CARBON R	RN72K1J-470JE	1	435034704R1	
PCB U003	R1158	C-CARBON R	RN72K1J-000JE	1	435030004R1	
PCB U003	R1159	C-CARBON R	RN72K1J-103JE	1	435031034R1	<MMA>
PCB U003	R1160	C-CARBON R	RN72K1J-000JE	1	435030004R1	<MDD>
PCB U003	R1160	C-CARBON R	RN72K1J-103JE	1	435031034R1	<MMA>
PCB U003	R1161	C-CARBON R	RN72K1J-472JE	1	435034724R1	
PCB U003	R1162	C-CARBON R	RN72K1J-472JE	1	435034724R1	
PCB U003	R1164	C-CARBON R	RN72K1J-472JE	1	435034724R1	
PCB U003	R1165	C-CARBON R	RN72K1J-472JE	1	435034724R1	
PCB U003	R1166	C-CARBON R	RN72K1J-472JE	1	435034724R1	
PCB U003	R1167	C-CARBON R	RN72K1J-472JE	1	435034724R1	
PCB U003	R1168	C-CARBON R	RN72K1J-272JE	1	435032724R1	
PCB U003	R1170	C-CARBON R	RN72K1J-272JE	1	435032724R1	
PCB U003	R1171	C-CARBON R	RN72K1J-272JE	1	435032724R1	
PCB U003	R1172	C-CARBON R	RN72K1J-272JE	1	435032724R1	
PCB U003	R1173	C-CARBON R	RN72K1J-470JE	1	435034704R1	
PCB U003	R1175	C-CARBON R	RN72K1J-473JE	1	435034734R1	
PCB U003	R1176	C-CARBON R	RN72K1J-473JE	1	435034734R1	
PCB U003	R1177	C-CARBON R	RN72K1J-473JE	1	435034734R1	
PCB U003	R1178	C-CARBON R	RN72K1J-272JE	1	435032724R1	
PCB U003	R1179	C-CARBON R	RN72K1J-272JE	1	435032724R1	



PCB U003	R1180	C-CARBON R	RN72K1J-473JE	1	435034734R1	
PCB U003	R1182	C-CARBON R	RN72K1J-470JE	1	435034704R1	
PCB U003	R1183	C-CARBON R	RN72K1J-470JE	1	435034704R1	
PCB U003	R1184	C-CARBON R	RN72K1J-470JE	1	435034704R1	
PCB U003	R1185	C-CARBON R	RN72K1J-000JE	1	435030004R1	
PCB U003	R1186	C-CARBON R	RN72K1J-221JE	1	435032214R1	
PCB U003	R1187	C-CARBON R	RN72K1J-470JE	1	435034704R1	
PCB U003	R1188	C-CARBON R	RN72K1J-470JE	1	435034704R1	
PCB U003	R1189	C-CARBON R	RN72K1J-470JE	1	435034704R1	
PCB U003	R1190	C-CARBON R	RN72K1J-470JE	1	435034704R1	
PCB U003	R1191	C-CARBON R	RN72K1J-470JE	1	435034704R1	
PCB U003	R1192	C-CARBON R	RN72K1J-470JE	1	435034704R1	
PCB U003	R1193	C-CARBON R	RN72K1J-470JE	1	435034704R1	
PCB U003	R1194	C-CARBON R	RN72K1J-221JE	1	435032214R1	
PCB U003	R1195	C-CARBON R	RN72K1J-221JE	1	435032214R1	
PCB U003	R1196	C-CARBON R	RN72K1J-470JE	1	435034704R1	
PCB U003	R1197	C-CARBON R	RN72K1J-470JE	1	435034704R1	
PCB U003	R1198	C-CARBON R	RN72K1J-470JE	1	435034704R1	
PCB U003	R1199	C-CARBON R	RN72K1J-470JE	1	435034704R1	
PCB U003	R1200	C-CARBON R	RN72K1J-473JE	1	435034734R1	
PCB U003	R1201	C-CARBON R	RN72K1J-473JE	1	435034734R1	
PCB U003	R1202	C-CARBON R	RN72K1J-103JE	1	435031034R1	
PCB U003	R1203	C-CARBON R	RN72K1J-103JE	1	435031034R1	
PCB U003	R1204	C-CARBON R	RN72K1J-224JE	1	435032244R1	
PCB U003	R1205	C-CARBON R	RN72K1J-472JE	1	435034724R1	
PCB U003	R1207	C-CARBON R	RN72K1J-473JE	1	435034734R1	
PCB U003	R1209	C-CARBON R	RN72K1J-473JE	1	435034734R1	
PCB U003	R1210	C-CARBON R	RN72K1J-473JE	1	435034734R1	
PCB U003	R1211	C-CARBON R	RN72K1J-473JE	1	435034734R1	
PCB U003	R1212	C-CARBON R	RN72K1J-473JE	1	435034734R1	
PCB U003	R1213	C-CARBON R	RN72K1J-272JE	1	435032724R1	
PCB U003	R1214	C-CARBON R	RN72K1J-272JE	1	435032724R1	
PCB U003	R1217	C-CARBON R	RN72K1J-103JE	1	435031034R1	
PCB U003	R1218	C-CARBON R	RN72K1J-103JE	1	435031034R1	
PCB U003	R1219	C-CARBON R	RN72K1J-332JE	1	435033324R1	
PCB U003	R1220	C-CARBON R	RN72K1J-103JE	1	435031034R1	<MDD>
PCB U003	R1221	C-CARBON R	RN72K1J-470JE	1	435034704R1	
PCB U003	R1222	C-CARBON R	RN72K1J-470JE	1	435034704R1	
PCB U003	R1223	C-CARBON R	RN72K1J-473JE	1	435034734R1	
PCB U003	R1224	C-CARBON R	RN72K1J-332JE	1	435033324R1	
PCB U003	R1225	C-CARBON R	RN72K1J-103JE	1	435031034R1	

PCB U003	R1226	C-CARBON R	RN72K1J-473JE	1	435034734R1
PCB U003	R1228	C-CARBON R	RN72K1J-473JE	1	435034734R1
PCB U003	R1230	C-CARBON R	RN72K1J-221JE	1	435032214R1
PCB U003	R1231	C-CARBON R	RN72K1J-102JE	1	435031024R1
PCB U003	R1235	C-CARBON R	RN72K1J-224JE	1	435032244R1
PCB U003	R1240	C-CARBON R	RN72K1J-103JE	1	435031034R1
PCB U003	R1241	C-CARBON R	RN72K1J-272JE	1	435032724R1
PCB U003	R1242	C-CARBON R	RN72K1J-470JE	1	435034704R1
PCB U003	R1243	C-CARBON R	RN72K1J-470JE	1	435034704R1
PCB U003	R1244	C-CARBON R	RN72K1J-470JE	1	435034704R1
PCB U003	R1245	C-CARBON R	RN72K1J-470JE	1	435034704R1
PCB U003	R1246	C-CARBON R	RN72K1J-221JE	1	435032214R1
PCB U003	R1248	C-CARBON R	RN72K1J-470JE	1	435034704R1
PCB U003	R1249	C-CARBON R	RN72K1J-000JE	1	435030004R1
PCB U003	R1250	C-CARBON R	RN72K1J-470JE	1	435034704R1
PCB U003	R1251	C-CARBON R	RN72K1J-470JE	1	435034704R1
PCB U003	R1252	C-CARBON R	RN72K1J-470JE	1	435034704R1
PCB U003	R1253	C-CARBON R	RN72K1J-473JE	1	435034734R1
PCB U003	R1254	C-CARBON R	RN72K1J-473JE	1	435034734R1
PCB U003	R1255	C-CARBON R	RN72K1J-473JE	1	435034734R1
PCB U003	R1264	C-CARBON R	RN72K1J-222JE	1	435032224R1
PCB U003	R1266	C-CARBON R	RN72K1J-222JE	1	435032224R1
PCB U003	R1267	C-CARBON R	RN72K1J-102JE	1	435031024R1
PCB U003	R1268	C-CARBON R	RN72K1J-221JE	1	435032214R1
PCB U003	R1270	C-CARBON R	RN72K1J-101JE	1	435031014R1
PCB U003	R1271	C-CARBON R	RN72K1J-102JE	1	435031024R1
PCB U003	R1272	C-CARBON R	RN72K1J-100JE	1	435031004R1
PCB U003	R1273	C-CARBON R	RN72K1J-000JE	1	435030004R1
PCB U003	R1274	C-CARBON R	RN72K1J-000JE	1	435030004R1
PCB U003	R1275	C-CARBON R	RN72K1J-823JE	1	435038234R1
PCB U003	R1280	C-CARBON R	RN72K1J-470JE	1	435034704R1
PCB U003	R1281	C-CARBON R	RN72K1J-470JE	1	435034704R1
PCB U003	R1282	C-CARBON R	RN72K1J-273JE	1	435032734R1
PCB U003	R1283	C-CARBON R	RN72K1J-470JE	1	435034704R1
PCB U003	R1284	C-CARBON R	RN72K1J-470JE	1	435034704R1
PCB U003	R1285	C-CARBON R	RN72K1J-470JE	1	435034704R1
PCB U003	R1286	C-CARBON R	RN72K1J-470JE	1	435034704R1
PCB U003	R1287	C-CARBON R	RN72K1J-470JE	1	435034704R1
PCB U003	R1288	C-CARBON R	RN72K1J-470JE	1	435034704R1
PCB U003	R1289	C-CARBON R	RN72K1J-104JE	1	435031044R1
PCB U003	R1290	C-CARBON R	RN72K1J-103JE	1	435031034R1

PCB U003	R1291	C-CARBON R	RN72K1J-104JE	1	435031044R1
PCB U003	R1292	C-CARBON R	RN72K1J-103JE	1	435031034R1
PCB U003	R1293	C-CARBON R	RN72K1J-473JE	1	435034734R1
PCB U003	R1294	C-CARBON R	RN72K1J-473JE	1	435034734R1
PCB U003	R1295	C-CARBON R	RN72K1J-473JE	1	435034734R1
PCB U003	R1296	C-CARBON R	RN72K1J-473JE	1	435034734R1
PCB U003	R1297	C-CARBON R	RN72K1J-473JE	1	435034734R1
PCB U003	R1298	C-CARBON R	RN72K1J-473JE	1	435034734R1
PCB U003	R1299	C-CARBON R	RN72K1J-102JE	1	435031024R1
PCB U003	R1300	THERMISTOR	FUSB090F	1	4000252T
PCB U003	R1301	METAL R	RNU1WCJ-4.7	1	453630474T
PCB U003	R1302	METAL R	RNU1WCJ-4.7	1	453630474T
PCB U003	R1303	METAL O R	RS1WBJ-22	1	443622204T
PCB U003	R1304	METAL O R	RS1WBJ-22	1	443622204T
PCB U003	R1311	C-CARBON R	RN72K1J-331JE	1	435033314R1
PCB U003	R1312	C-CARBON R	RN72K1J-331JE	1	435033314R1
PCB U003	R1313	C-CARBON R	RN72K1J-331JE	1	435033314R1
PCB U003	R1315	C-CARBON R	RN72K1J-331JE	1	435033314R1
PCB U003	R1316	C-CARBON R	RN72K1J-331JE	1	435033314R1
PCB U003	R1317	C-CARBON R	RN72K1J-470JE	1	435034704R1
PCB U003	R1318	C-CARBON R	RN72K1J-470JE	1	435034704R1
PCB U003	R1319	C-CARBON R	RN72K1J-331JE	1	435033314R1
PCB U003	R1320	C-CARBON R	RN72K1J-331JE	1	435033314R1
PCB U003	R1321	C-CARBON R	RN72K1J-470JE	1	435034704R1
PCB U003	R1322	C-CARBON R	RN72K1J-331JE	1	435033314R1
PCB U003	R1323	C-CARBON R	RN72K1J-331JE	1	435033314R1
PCB U003	R1325	C-CARBON R	RN72K1J-470JE	1	435034704R1
PCB U003	R1485	C-CARBON R	RN72K1J-100JE	1	435031004R1
PCB U003	R1486	C-CARBON R	RN72K1J-100JE	1	435031004R1
PCB U003	R1487	C-CARBON R	RN72K1J-750JE	1	435037504R1
PCB U003	R1488	C-CARBON R	RN72K1J-224JE	1	435032244R1
PCB U003	R1490	C-CARBON R	RN72K1J-750JE	1	435037504R1
PCB U003	R1491	C-CARBON R	RN72K1J-224JE	1	435032244R1
PCB U003	R1492	C-CARBON R	RN72K1J-100JE	1	435031004R1
PCB U003	R1496	C-CARBON R	RN72K1J-750JE	1	435037504R1
PCB U003	R1497	C-CARBON R	RN72K1J-224JE	1	435032244R1
PCB U003	R1500	C-CARBON R	RN72K1J-392JE	1	435033924R1
PCB U003	R1504	C-CARBON R	RN72K1J-221JE	1	435032214R1
PCB U003	R1506	C-CARBON R	RN72K1J-470JE	1	435034704R1
PCB U003	R1507	C-CARBON R	RN72K1J-152JE	1	435031524R1
PCB U003	R1508	C-CARBON R	RN72K1J-102JE	1	435031024R1

PCB U003	R1509	C-CARBON R	RN72K1J-331JE	1	435033314R1
PCB U003	R1510	C-CARBON R	RN72K1J-331JE	1	435033314R1
PCB U003	R1511	C-CARBON R	RN72K1J-102JE	1	435031024R1
PCB U003	R1512	C-CARBON R	RN72K1J-470JE	1	435034704R1
PCB U003	R1513	C-CARBON R	RN72K1J-331JE	1	435033314R1
PCB U003	R1514	C-CARBON R	RN72K1J-102JE	1	435031024R1
PCB U003	R1515	C-CARBON R	RN72K1J-331JE	1	435033314R1
PCB U003	R1517	C-CARBON R	RN72K1J-331JE	1	435033314R1
PCB U003	R1518	C-CARBON R	RN72K1J-331JE	1	435033314R1
PCB U003	R1519	C-CARBON R	RN72K1J-331JE	1	435033314R1
PCB U003	R1520	C-CARBON R	RN72K1J-470JE	1	435034704R1
PCB U003	R1521	C-CARBON R	RN72K1J-823JE	1	435038234R1
PCB U003	R1522	C-CARBON R	RN72K1J-103JE	1	435031034R1
PCB U003	R1523	C-CARBON R	RN72K1J-103JE	1	435031034R1
PCB U003	R1524	C-CARBON R	RN72K1J-823JE	1	435038234R1
PCB U003	R1525	C-CARBON R	RN72K1J-470JE	1	435034704R1
PCB U003	R1526	C-CARBON R	RN72K1J-470JE	1	435034704R1
PCB U003	R1527	C-CARBON R	RN72K1J-221JE	1	435032214R1
PCB U003	R1528	C-CARBON R	RN72K1J-470JE	1	435034704R1
PCB U003	R1529	C-CARBON R	RN72K1J-470JE	1	435034704R1
PCB U003	R1530	C-CARBON R	RN72K1J-470JE	1	435034704R1
PCB U003	R1531	C-CARBON R	RN72K1J-470JE	1	435034704R1
PCB U003	R1532	C-CARBON R	RN72K1J-103JE	1	435031034R1
PCB U003	R1534	C-CARBON R	RN72K1J-823JE	1	435038234R1
PCB U003	R1535	C-CARBON R	RN72K1J-105JE	1	435031054R1
PCB U003	R1567	C-CARBON R	RN72K1J-220JE	1	435032204R1
PCB U003	R1568	C-CARBON R	RN72K1J-220JE	1	435032204R1
PCB U003	R1569	C-CARBON R	RN72K1J-220JE	1	435032204R1
PCB U003	R1570	C-CARBON R	RN72K1J-220JE	1	435032204R1
PCB U003	R1571	C-CARBON R	RN72K1J-220JE	1	435032204R1
PCB U003	R1572	C-CARBON R	RN72K1J-220JE	1	435032204R1
PCB U003	R1573	C-CARBON R	RN72K1J-221JE	1	435032214R1
PCB U003	R1575	C-CARBON R	RN72K1J-331JE	1	435033314R1
PCB U003	R1577	C-CARBON R	RN72K1J-331JE	1	435033314R1
PCB U003	R1579	C-CARBON R	RN72K1J-331JE	1	435033314R1
PCB U003	R1580	C-CARBON R	RN72K1J-472JE	1	435034724R1
PCB U003	R1581	C-CARBON R	RN72K1J-472JE	1	435034724R1
PCB U003	R1599	C-CARBON R	RN72K1J-392JE	1	435033924R1
PCB U003	R1600	C-CARBON R	RN72K1J-153JE	1	435031534R1
PCB U003	R1601	C-CARBON R	RN72K1J-153JE	1	435031534R1
PCB U003	R1602	C-CARBON R	RN72K1J-153JE	1	435031534R1



PCB U003	R1654	C-CARBON R	RN72K1J-123JE	1	435031234R1
PCB U003	R1655	C-CARBON R	RN72K1J-123JE	1	435031234R1
PCB U003	R1656	C-CARBON R	RN72K1J-123JE	1	435031234R1
PCB U003	R1657	C-CARBON R	RN72K1J-123JE	1	435031234R1
PCB U003	R1660	C-CARBON R	RN72K1J-182JE	1	435031824R1
PCB U003	R1661	C-CARBON R	RN72K1J-182JE	1	435031824R1
PCB U003	R1662	C-CARBON R	RN72K1J-182JE	1	435031824R1
PCB U003	R1663	C-CARBON R	RN72K1J-182JE	1	435031824R1
PCB U003	R1664	C-CARBON R	RN72K1J-182JE	1	435031824R1
PCB U003	R1665	C-CARBON R	RN72K1J-182JE	1	435031824R1
PCB U003	R1666	C-CARBON R	RN72K1J-182JE	1	435031824R1
PCB U003	R1667	C-CARBON R	RN72K1J-182JE	1	435031824R1
PCB U003	R1670	C-CARBON R	RN72K1J-182JE	1	435031824R1
PCB U003	R1671	C-CARBON R	RN72K1J-182JE	1	435031824R1
PCB U003	R1672	C-CARBON R	RN72K1J-182JE	1	435031824R1
PCB U003	R1673	C-CARBON R	RN72K1J-182JE	1	435031824R1
PCB U003	R1674	C-CARBON R	RN72K1J-182JE	1	435031824R1
PCB U003	R1675	C-CARBON R	RN72K1J-182JE	1	435031824R1
PCB U003	R1676	C-CARBON R	RN72K1J-182JE	1	435031824R1
PCB U003	R1677	C-CARBON R	RN72K1J-182JE	1	435031824R1
PCB U003	R1770	C-CARBON R	RN72K1J-000JE	1	435030004R1
PCB U003	R1771	C-CARBON R	RN72K1J-000JE	1	435030004R1
PCB U003	R1772	C-CARBON R	RN72K1J-000JE	1	435030004R1
PCB U003	R1773	C-CARBON R	RN72K1J-000JE	1	435030004R1
PCB U003	R1774	C-CARBON R	RN72K1J-000JE	1	435030004R1
PCB U003	R1775	C-CARBON R	RN72K1J-000JE	1	435030004R1
PCB U003	R1776	C-CARBON R	RN72K1J-000JE	1	435030004R1
PCB U003	R1777	C-CARBON R	RN72K1J-000JE	1	435030004R1
PCB U003	R1780	METAL O R	RS1/2WBJ-22	1	443522204T
PCB U003	R1781	METAL O R	RS1/2WBJ-22	1	443522204T
PCB U003	R1800	C-CARBON R	RN72K1J-101JE	1	435031014R1
PCB U003	R1801	C-CARBON R	RN72K1J-101JE	1	435031014R1
PCB U003	R1810	C-CARBON R	RN72K1J-101JE	1	435031014R1
PCB U003	R1811	C-CARBON R	RN72K1J-101JE	1	435031014R1
PCB U003	R1820	C-CARBON R	RN72K1J-103JE	1	435031034R1
PCB U003	R1821	C-CARBON R	RN72K1J-103JE	1	435031034R1
PCB U003	R1830	C-CARBON R	RN72K1J-103JE	1	435031034R1
PCB U003	R1831	C-CARBON R	RN72K1J-103JE	1	435031034R1
PCB U003	R1840	C-CARBON R	RN72K1J-103JE	1	435031034R1
PCB U003	R1841	C-CARBON R	RN72K1J-103JE	1	435031034R1
PCB U003	R1850	C-CARBON R	RN72K1J-103JE	1	435031034R1

PCB U003	R1851	C-CARBON R	RN72K1J-103JE	1	435031034R1	
PCB U003	R1860	C-CARBON R	RN72K1J-103JE	1	435031034R1	
PCB U003	R1861	C-CARBON R	RN72K1J-103JE	1	435031034R1	
PCB U003	R1900	C-CARBON R	RN72K1J-104JE	1	435031044R1	
PCB U003	R1901	C-CARBON R	RN72K1J-104JE	1	435031044R1	
PCB U003	R1902	C-CARBON R	RN72K1J-105JE	1	435031054R1	
PCB U003	R1904	C-CARBON R	RN72K1J-223JE	1	435032234R1	
PCB U003	R1905	C-CARBON R	RN72K1J-223JE	1	435032234R1	
PCB U003	R1906	C-CARBON R	RN72K1J-223JE	1	435032234R1	
PCB U003	R1907	C-CARBON R	RN72K1J-223JE	1	435032234R1	
PCB U003	R1908	C-CARBON R	RN72K1J-471JE	1	435034714R1	
PCB U003	R1909	C-CARBON R	RN72K1J-471JE	1	435034714R1	
PCB U003	R1910	C-CARBON R	RN72K1J-223JE	1	435032234R1	
PCB U003	R1911	C-CARBON R	RN72K1J-223JE	1	435032234R1	
PCB U003	R1912	C-CARBON R	RN72K1J-220JE	1	435032204R1	
PCB U003	R1913	C-CARBON R	RN72K1J-220JE	1	435032204R1	
PCB U003	R1920	C-CARBON R	RN72K1J-223JE	1	435032234R1	
PCB U003	R1921	C-CARBON R	RN72K1J-223JE	1	435032234R1	
PCB U003	R1951	C-CARBON R	RN72K1J-220JE	1	435032204R1	
PCB U003	R1952	C-CARBON R	RN72K1J-220JE	1	435032204R1	
PCB U003	R1953	C-CARBON R	RN72K1J-750JE	1	435037504R1	
PCB U003	R1954	C-CARBON R	RN72K1J-222JE	1	435032224R1	
PCB U003	R1955	C-CARBON R	RN72K1J-220JE	1	435032204R1	
PCB U003	R1956	C-CARBON R	RN72K1J-105JE	1	435031054R1	
PCB U003	R1961	C-CARBON R	RN72K1J-220JE	1	435032204R1	
PCB U003	R1962	C-CARBON R	RN72K1J-220JE	1	435032204R1	
PCB U003	R1963	C-CARBON R	RN72K1J-750JE	1	435037504R1	
PCB U003	R1964	C-CARBON R	RN72K1J-222JE	1	435032224R1	
PCB U003	R1965	C-CARBON R	RN72K1J-220JE	1	435032204R1	
PCB U003	R1971	C-CARBON R	RN72K1J-220JE	1	435032204R1	
PCB U003	R1972	C-CARBON R	RN72K1J-220JE	1	435032204R1	
PCB U003	R1973	C-CARBON R	RN72K1J-750JE	1	435037504R1	
PCB U003	R1974	C-CARBON R	RN72K1J-222JE	1	435032224R1	
PCB U003	R1975	C-CARBON R	RN72K1J-220JE	1	435032204R1	
PCB U003	R1980	THERMISTOR	FUSB090F	1	4000252T	
PCB U003	R39	C-CARBON R	RN72K1J-220JE	1	435032204R1	<MDD>
PCB U003	R4000	METAL R	RNU1/2WCJ-4.7	1	453530474T	
PCB U003	R4001	C-CARBON R	RN72K1J-103JE	1	435031034R1	
PCB U003	R4002	METAL R	RNU1WCJ-0.22	1	453632294T	
PCB U003	R4003	METAL R	RNU1/2WCJ-0.47	1	453534794T	
PCB U003	R4004	C-CARBON R	RN72K1J-562JE	1	435035624R1	

PCB U003	R4005	C-CARBON R	RN72K1J-152JE	1	435031524R1	
PCB U003	R4006	C-CARBON R	RN72K1J-102JE	1	435031024R1	
PCB U003	R4007	C-CARBON R	RN72K1J-392JE	1	435033924R1	
PCB U003	R4008	C-CARBON R	RN72K2E-022JE	1	435220224R1	
PCB U003	R4022	METAL O R	RS2WB3-3.3	1	441720334F	
PCB U003	R4024	C-CARBON R	RN72K1J-470JE	1	435034704R1	
PCB U003	R41	C-CARBON R	RN72K1J-220JE	1	435032204R1	<MDD>
PCB U003	R4103	C-CARBON R	RN72K1J-750JE	1	435037504R1	
PCB U003	R4104	C-CARBON R	RN72K1J-750JE	1	435037504R1	
PCB U003	R4105	C-CARBON R	RN72K1J-750JE	1	435037504R1	
PCB U003	R4106	C-CARBON R	RN72K1J-000JE	1	435030004R1	
PCB U003	R4107	C-CARBON R	RN72K1J-000JE	1	435030004R1	
PCB U003	R4108	C-CARBON R	RN72K1J-101JE	1	435031014R1	
PCB U003	R4109	C-CARBON R	RN72K1J-000JE	1	435030004R1	
PCB U003	R4110	C-CARBON R	RN72K1J-750JE	1	435037504R1	
PCB U003	R4111	C-CARBON R	RN72K1J-392JE	1	435033924R1	
PCB U003	R4112	C-CARBON R	RN72K1J-750JE	1	435037504R1	
PCB U003	R4113	C-CARBON R	RN72K1J-101JE	1	435031014R1	
PCB U003	R4114	C-CARBON R	RN72K1J-000JE	1	435030004R1	
PCB U003	R4115	C-CARBON R	RN72K1J-750JE	1	435037504R1	
PCB U003	R4116	C-CARBON R	RN72K1J-000JE	1	435030004R1	
PCB U003	R4117	C-CARBON R	RN72K1J-750JE	1	435037504R1	
PCB U003	R4118	C-CARBON R	RN72K1J-000JE	1	435030004R1	
PCB U003	R4119	C-CARBON R	RN72K2E-022JE	1	435220224R1	
PCB U003	R4120	C-CARBON R	RN72K1J-750JE	1	435037504R1	
PCB U003	R4121	C-CARBON R	RN72K1J-750JE	1	435037504R1	
PCB U003	R4122	C-CARBON R	RN72K1J-750JE	1	435037504R1	
PCB U003	R4123	C-CARBON R	RN72K1J-104JE	1	435031044R1	
PCB U003	R4124	C-CARBON R	RN72K1J-750JE	1	435037504R1	
PCB U003	R4125	C-CARBON R	RN72K1J-104JE	1	435031044R1	
PCB U003	R4126	C-CARBON R	RN72K1J-750JE	1	435037504R1	
PCB U003	R4127	C-CARBON R	RN72K1J-104JE	1	435031044R1	
PCB U003	R4129	C-CARBON R	RN72K1J-750JE	1	435037504R1	
PCB U003	R4130	C-CARBON R	RN72K1J-104JE	1	435031044R1	
PCB U003	R4131	C-CARBON R	RN72K1J-750JE	1	435037504R1	
PCB U003	R4132	C-CARBON R	RN72K1J-104JE	1	435031044R1	
PCB U003	R4133	C-CARBON R	RN72K1J-750JE	1	435037504R1	
PCB U003	R4134	C-CARBON R	RN72K1J-104JE	1	435031044R1	
PCB U003	R4135	C-CARBON R	RN72K1J-750JE	1	435037504R1	
PCB U003	R4136	C-CARBON R	RN72K1J-750JE	1	435037504R1	
PCB U003	R4137	C-CARBON R	RN72K1J-750JE	1	435037504R1	



PCB U003	R4138	C-CARBON R	RN72K2E-022JE	1	435220224R1
PCB U003	R4139	C-CARBON R	RN72K1J-750JE	1	435037504R1
PCB U003	R4140	C-CARBON R	RN72K1J-750JE	1	435037504R1
PCB U003	R4141	C-CARBON R	RN72K1J-750JE	1	435037504R1
PCB U003	R4142	C-CARBON R	RN72K1J-750JE	1	435037504R1
PCB U003	R4143	C-CARBON R	RN72K1J-750JE	1	435037504R1
PCB U003	R4144	C-CARBON R	RN72K1J-750JE	1	435037504R1
PCB U003	R4145	C-CARBON R	RN72K1J-104JE	1	435031044R1
PCB U003	R4146	C-CARBON R	RN72K1J-104JE	1	435031044R1
PCB U003	R4147	C-CARBON R	RN72K1J-104JE	1	435031044R1
PCB U003	R4148	C-CARBON R	RN72K1J-392JE	1	435033924R1
PCB U003	R4149	C-CARBON R	RN72K1J-750JE	1	435037504R1
PCB U003	R4150	C-CARBON R	RN72K1J-750JE	1	435037504R1
PCB U003	R4151	C-CARBON R	RN72K1J-750JE	1	435037504R1
PCB U003	R4152	C-CARBON R	RN72K1J-101JE	1	435031014R1
PCB U003	R4153	C-CARBON R	RN72K1J-101JE	1	435031014R1
PCB U003	R4155	C-CARBON R	RN72K1J-750JE	1	435037504R1
PCB U003	R4156	C-CARBON R	RN72K1J-750JE	1	435037504R1
PCB U003	R4157	C-CARBON R	RN72K1J-750JE	1	435037504R1
PCB U003	R4158	C-CARBON R	RN72K1J-000JE	1	435030004R1
PCB U003	R4159	C-CARBON R	RN72K1J-750JE	1	435037504R1
PCB U003	R4160	C-CARBON R	RN72K2E-022JE	1	435220224R1
PCB U003	R4161	C-CARBON R	RN72K1J-750JE	1	435037504R1
PCB U003	R4162	C-CARBON R	RN72K1J-750JE	1	435037504R1
PCB U003	R4163	C-CARBON R	RN72K1J-104JE	1	435031044R1
PCB U003	R4164	C-CARBON R	RN72K1J-104JE	1	435031044R1
PCB U003	R4165	C-CARBON R	RN72K1J-104JE	1	435031044R1
PCB U003	R4166	C-CARBON R	RN72K1J-104JE	1	435031044R1
PCB U003	R4167	C-CARBON R	RN72K1J-104JE	1	435031044R1
PCB U003	R4168	C-CARBON R	RN72K1J-101JE	1	435031014R1
PCB U003	R4169	C-CARBON R	RN72K1J-101JE	1	435031014R1
PCB U003	R4170	C-CARBON R	RN72K2E-022JE	1	435220224R1
PCB U003	R4171	C-CARBON R	RN72K2E-022JE	1	435220224R1
PCB U003	R4172	C-CARBON R	RN72K1J-682JE	1	435036824R1
PCB U003	R4173	C-CARBON R	RN72K1J-682JE	1	435036824R1
PCB U003	R4174	C-CARBON R	RN72K2E-022JE	1	435220224R1
PCB U003	R4175	C-CARBON R	RN72K1J-000JE	1	435030004R1
PCB U003	R4176	C-CARBON R	RN72K1J-000JE	1	435030004R1
PCB U003	R4177	C-CARBON R	RN72K1J-000JE	1	435030004R1
PCB U003	R4181	C-CARBON R	RN72K1J-000JE	1	435030004R1
PCB U003	R4182	C-CARBON R	RN72K1J-000JE	1	435030004R1

PCB U003	R4183	C-CARBON R	RN72K1J-000JE	1	435030004R1	
PCB U003	R4187	C-CARBON R	RN72K1J-104JE	1	435031044R1	
PCB U003	R4189	C-CARBON R	RN72K1J-104JE	1	435031044R1	
PCB U003	R4199	C-CARBON R	RN72K1J-000JE	1	435030004R1	
PCB U003	R4200	C-CARBON R	RN72K1J-104JE	1	435031044R1	
PCB U003	R4201	C-CARBON R	RN72K1J-103JE	1	435031034R1	
PCB U003	R4202	C-CARBON R	RN72K1J-101JE	1	435031014R1	
PCB U003	R4203	C-CARBON R	RN72K1J-000JE	1	435030004R1	
PCB U003	R4205	C-CARBON R	RN72K1J-101JE	1	435031014R1	
PCB U003	R4206	C-CARBON R	RN72K1J-000JE	1	435030004R1	
PCB U003	R4207	C-CARBON R	RN72K2E-022JE	1	435220224R1	
PCB U003	R4208	C-CARBON R	RN72K1J-104JE	1	435031044R1	
PCB U003	R4209	C-CARBON R	RN72K1J-392JE	1	435033924R1	
PCB U003	R4211	C-CARBON R	RN72K1J-103JE	1	435031034R1	
PCB U003	R4212	C-CARBON R	RN72K1J-103JE	1	435031034R1	
PCB U003	R4213	C-CARBON R	RN72K1J-000JE	1	435030004R1	
PCB U003	R4214	C-CARBON R	RN72K1J-000JE	1	435030004R1	
PCB U003	R4215	C-CARBON R	RN72K1J-105JE	1	435031054R1	
PCB U003	R4216	C-CARBON R	RN72K1J-105JE	1	435031054R1	
PCB U003	R4217	C-CARBON R	RN72K1J-105JE	1	435031054R1	
PCB U003	R4218	C-CARBON R	RN72K1J-105JE	1	435031054R1	
PCB U003	R4219	C-CARBON R	RN72K1J-105JE	1	435031054R1	
PCB U003	R4220	C-CARBON R	RN72K1J-105JE	1	435031054R1	
PCB U003	R4221	C-CARBON R	RN72K1J-105JE	1	435031054R1	
PCB U003	R4222	C-CARBON R	RN72K1J-105JE	1	435031054R1	
PCB U003	R4223	C-CARBON R	RN72K1J-105JE	1	435031054R1	
PCB U003	R4224	C-CARBON R	RN72K1J-105JE	1	435031054R1	
PCB U003	R4225	C-CARBON R	RN72K1J-105JE	1	435031054R1	
PCB U003	R4226	C-CARBON R	RN72K1J-105JE	1	435031054R1	
PCB U003	R4227	C-CARBON R	RN72K1J-682JE	1	435036824R1	
PCB U003	R4228	C-CARBON R	RN72K1J-222JE	1	435032224R1	
PCB U003	R4229	C-CARBON R	RN72K1J-331JE	1	435033314R1	
PCB U003	R4233	C-CARBON R	RN72K1J-222JE	1	435032224R1	
PCB U003	R4235	C-CARBON R	RN72K1J-222JE	1	435032224R1	
PCB U003	R4238	C-CARBON R	RN72K1J-222JE	1	435032224R1	
PCB U003	R4247	C-CARBON R	RN72K1J-750JE	1	435037504R1	
PCB U003	R4248	C-CARBON R	RN72K1J-104JE	1	435031044R1	
PCB U003	R4258	C-CARBON R	RN72K2E-022JE	1	435220224R1	
PCB U003	R43	C-CARBON R	RN72K1J-000JE	1	435030004R1	<MDD>
PCB U003	R44	NF CARBON R	R25J-10	1	415471004T	
PCB U003	R45	NF CARBON R	R25J-10	1	415471004T	

PCB U003	R4500	C-CARBON R	RN72K1J-223JE	1	435032234R1	
PCB U003	R4501	C-CARBON R	RN72K1J-101JE	1	435031014R1	
PCB U003	R4502	C-CARBON R	RN72K1J-473JE	1	435034734R1	
PCB U003	R4503	C-CARBON R	RN72K1J-473JE	1	435034734R1	
PCB U003	R4504	C-CARBON R	RN72K1J-151JE	1	435031514R1	
PCB U003	R4505	C-CARBON R	RN72K1J-223JE	1	435032234R1	
PCB U003	R4506	C-CARBON R	RN72K1J-122JE	1	435031224R1	
PCB U003	R4507	C-CARBON R	RN72K1J-473JE	1	435034734R1	
PCB U003	R4508	C-CARBON R	RN72K1J-182JE	1	435031824R1	
PCB U003	R4509	C-CARBON R	RN72K1J-331JE	1	435033314R1	
PCB U003	R4510	C-CARBON R	RN72K1J-562JE	1	435035624R1	
PCB U003	R4511	METAL R	RNU1WCJ-1	1	453630104T	
PCB U003	R4512	C-CARBON R	RN72K1J-223JE	1	435032234R1	
PCB U003	R46	C-CARBON R	RN72K1J-103JE	1	435031034R1	<MMA>
PCB U003	R47	C-CARBON R	RN72K1J-101JE	1	435031014R1	<MMA>
PCB U003	R4700	C-CARBON R	RN72K1J-103JE	1	435031034R1	
PCB U003	R4701	C-CARBON R	RN72K1J-103JE	1	435031034R1	
PCB U003	R4702	C-CARBON R	RN72K1J-331JE	1	435033314R1	
PCB U003	R4703	C-CARBON R	RN72K1J-331JE	1	435033314R1	
PCB U003	R4704	C-CARBON R	RN72K1J-103JE	1	435031034R1	
PCB U003	R4705	C-CARBON R	RN72K1J-331JE	1	435033314R1	
PCB U003	R4707	C-CARBON R	RN72K1J-331JE	1	435033314R1	
PCB U003	R48	C-CARBON R	RN72K1J-101JE	1	435031014R1	<MMA>
PCB U003	R49	C-CARBON R	RN72K1J-103JE	1	435031034R1	
PCB U003	R50	C-CARBON R	RN72K1J-103JE	1	435031034R1	
PCB U003	R51	C-CARBON R	RN72K1J-273JE	1	435032734R1	
PCB U003	R52	C-CARBON R	RN72K1J-273JE	1	435032734R1	
PCB U003	R53	C-CARBON R	RN72K1J-223JE	1	435032234R1	
PCB U003	R54	C-CARBON R	RN72K1J-103JE	1	435031034R1	
PCB U003	R55	C-CARBON R	RN72K1J-103JE	1	435031034R1	
PCB U003	R56	C-CARBON R	RN72K1J-223JE	1	435032234R1	
PCB U003	R57	C-CARBON R	RN72K1J-103JE	1	435031034R1	<MDD>
PCB U003	R58	C-CARBON R	RN72K1J-103JE	1	435031034R1	<MDD>
PCB U003	R59	C-CARBON R	RN72K1J-103JE	1	435031034R1	<MDD>
PCB U003	R60	C-CARBON R	RN72K1J-103JE	1	435031034R1	<MDD>
PCB U003	R61	C-CARBON R	RN72K1J-103JE	1	435031034R1	<MDD>
PCB U003	R62	C-CARBON R	RN72K1J-103JE	1	435031034R1	<MDD>
PCB U003	R63	C-CARBON R	RN72K1J-103JE	1	435031034R1	<MDD>
PCB U003	R64	C-CARBON R	RN72K1J-103JE	1	435031034R1	<MDD>
PCB U003	[SW TRM]					
PCB U003	E1911	TRM-423(SCREW)	NEJITANSI ST3	1	25060495	

PCB U003	F4000A	FUSE HOL	NSCT-1P2031	1	25052133T	
PCB U003	F4000B	FUSE HOL	NSCT-1P2031	1	25052133T	
PCB U003	F4001A	FUSE HOL	NSCT-1P2031	1	25052133T	
PCB U003	F4001B	FUSE HOL	NSCT-1P2031	1	25052133T	
PCB U003	JL104B	WIRE TRAP	NPLG-9P592	1	25055630	
PCB U003	JL4500B	WIRE TRAP	NPLG-3P586	1	25055624	
PCB U003	JL5515A	WIRE HOL	NSCT-11P882	1	25051095	
PCB U003	JL8002A	WIRE HOL	NSCT-5P896	1	25051109	
PCB U003	JL901B	WIRE TRAP	NPLG-5P588	1	25055626	
PCB U003	P001	PWB	BCDG-0099	1	25140099C	N
PCB U003	P002	PWB	BCCPU-0100	{ 1 }	25140100	N
PCB U003	P003	PWB	BCVD-0101	{ 1 }	25140101	N
PCB U003	P005	PWB	BCETC-0103	{ 1 }	25140103	N
PCB U003	P1004A	SOCKET	NSCT-9P2243	1	25052346	
PCB U003	P1008B	PLUG	IMSA-9142B-20A	1	25056600	
PCB U003	P1010B	PLUG	IMSA-9142B-20A	1	25056600	
PCB U003	P103B	SOCKET	NSCT-11P2104	1	25052207	
PCB U003	P1208	ST JACK	MSJ-035-22	1	25045887	
PCB U003	P1307	TRM-423(SCREW)	NEJITANSI ST3	1	25060495	
PCB U003	P1309	PIN JACK	NPJ-3PDO657	1	25045885	
PCB U003	P1309 or	PIN JACK	NPJ-3PDO431	( 1 )	25045624	
PCB U003	P1901A	PLUG	IMSA-9142B-22A	1	25056601	N
PCB U003	P1901B	SOCKET	IMSA-9142S-22A	1	25053233	N
PCB U003	P1902	SOCKET	NNA1-01-006	1	25053357	
PCB U003	P3605B	SOCKET	IMSA-9142S-18A	1	25053231	
PCB U003	P3607B	SOCKET	IMSA-9142S-16A	1	25053230	
PCB U003	P3608B	SOCKET	IMSA-9142S-18A	1	25053231	
PCB U003	P4000B	PLUG	NPLG-5P119	1	25055135	
PCB U003	P4100A	PLUG	IMSA-9142B-16A	1	25056598	
PCB U003	P4100B	SOCKET	IMSA-9142S-16A	1	25053230	
PCB U003	P4101A	PLUG	IMSA-9142B-18A	1	25056599	
PCB U003	P4101B	SOCKET	IMSA-9142S-18A	1	25053231	
PCB U003	P4104A	SOCKET	NSCT-31P2124	1	25052227	
PCB U003	P4108	PIN JACK	NPJ-9PDGLR630	1	25045851	
PCB U003	P4108 or	PIN JACK	NPJ-9PDGLR520	( 1 )	25045732	
PCB U003	P4109	PIN JACK	NPJ-6PDGLR649	1	25045874	
PCB U003	P4112	PIN JACK	NPJ-10PDSY628	1	25045849	
PCB U003	P4112 or	PIN JACK	NPJ-10PDBY481	( 1 )	25045684	
PCB U003	P4113	PIN JACK	NPJ-10PDSY628	1	25045849	
PCB U003	P4113 or	PIN JACK	NPJ-10PDBY481	( 1 )	25045684	
PCB U003	P4114	PIN JACK	NPJ-10PDSY628	1	25045849	

PCB U003	P4114 or	PIN JACK	NPJ-10PDBY481	(1)	25045684	
PCB U003	P4115	PIN JACK	NPJ-1PDY655	1	25045882	
PCB U003	P4115 or	PIN JACK	NPJ-1PDYE402	(1)	25045591	
PCB U003	P4118	TRM-423(SCREW)	NEJITANSI ST3	1	25060495	
PCB U003	P4119	RETAINER	(JOINT)	1	27142069	
PCB U003	P4501	PLUG	NPLG-2P83	1	25055099	
PCB U003	P4700	SOCKET	MDS-09P-V-01(DSUB9P)	1	25053363	
PCB U003	P5512B	PLUG	NPLG-15P0970	1	25056020	
PCB U003	P5513B	PLUG	NPLG-19P0974	1	25056024	
PCB U003	P5518B	PLUG	NPLG-3P0958	1	25056008	
PCB U003	P6621B	PLUG	IMSA-9142B-16A	1	25056598	
PCB U003	P7501A	PLUG	A2545WR2-2x20P(IDE40SIDE)	1	25056643	N
PCB U003	P8	SOCKET	2MJ-3516-002	1	25053355	<MDD>

PCB U004	<b>U0040</b>	DISPLAY CIRCUIT PC BOARD (BADIS-0121-1A)
PCB U004	<b>U0041</b>	STANDBY SWITCH PC BOARD (BASW-0122-1A)
PCB U004	<b>U0042</b>	HEADPHONE TERMINAL PC BOARD (BAETC-0123-1A)
PCB U004	<b>U0043</b>	FRONT DIGITAL INPUT PC BOARD (BAETC-0124-1A)
PCB U004	<b>U0044</b>	VOLUME PC BOARD (BAETC-0125-1A)
PCB U004	<b>U0045</b>	FUSE PC BOARD (BAPS-0126-1A)
PCB U004	<b>U0048</b>	SUPPORT PC BOARD-3 (BAETC-0129-1A)

CIRCUIT. NO.	PART NAME	DESCRIPTION	Q'TY	PART NO. (SN)	REMARKS
PCB U004	<b>[TUNER UNIT]</b>				
PCB U004	U7520	PHT CP	1	24120138	
PCB U004	U7560	REMO SENS	1	24130017	
PCB U004	<b>[SEMI CONDUCTOR]</b>				
PCB U004	D7500	ZENER D	1	224551000R2	
PCB U004	D7520	C-DIODE	1	223269R2	
PCB U004	D7520 or	C-DIODE	(1)	223234R2	
PCB U004	D7520 or	C-DIODE	(1)	223279R2	
PCB U004	D7520 or	C-DIODE	(1)	223283R2	
PCB U004	D7521	C-DIODE	1	223269R2	
PCB U004	D7521 or	C-DIODE	(1)	223234R2	
PCB U004	D7521 or	C-DIODE	(1)	223279R2	
PCB U004	D7521 or	C-DIODE	(1)	223283R2	
PCB U004	D7522	C-DIODE	1	223269R2	
PCB U004	D7522 or	C-DIODE	(1)	223234R2	
PCB U004	D7522 or	C-DIODE	(1)	223279R2	
PCB U004	D7522 or	C-DIODE	(1)	223283R2	
PCB U004	D7523	C-DIODE	1	223269R2	

PCB U004	D7523 or	C-DIODE	ISS352	(1)	223234R2
PCB U004	D7523 or	C-DIODE	MA2J111	(1)	223279R2
PCB U004	D7523 or	C-DIODE	KDS4148U	(1)	223283R2
PCB U004	D7530	ZENER D	UDZS5.1B	1	224550510R2
PCB U004	D7531	C-DIODE	ISS355	1	223269R2
PCB U004	D7531 or	C-DIODE	ISS352	(1)	223234R2
PCB U004	D7531 or	C-DIODE	MA2J111	(1)	223279R2
PCB U004	D7531 or	C-DIODE	KDS4148U	(1)	223283R2
PCB U004	D7532	C-DIODE	ISS355	1	223269R2
PCB U004	D7532 or	C-DIODE	ISS352	(1)	223234R2
PCB U004	D7532 or	C-DIODE	MA2J111	(1)	223279R2
PCB U004	D7532 or	C-DIODE	KDS4148U	(1)	223283R2
PCB U004	D7560	C-DIODE	ISS355	1	223269R2
PCB U004	D7560 or	C-DIODE	ISS352	(1)	223234R2
PCB U004	D7560 or	C-DIODE	MA2J111	(1)	223279R2
PCB U004	D7560 or	C-DIODE	KDS4148U	(1)	223283R2
PCB U004	D7561	C-DIODE	ISS355	1	223269R2
PCB U004	D7561 or	C-DIODE	ISS352	(1)	223234R2
PCB U004	D7561 or	C-DIODE	MA2J111	(1)	223279R2
PCB U004	D7561 or	C-DIODE	KDS4148U	(1)	223283R2
PCB U004	D7570	SPCF D	TSAL5300	1	225488
PCB U004	D7580	C-DIODE	ISS355	1	223269R2
PCB U004	D7580 or	C-DIODE	ISS352	(1)	223234R2
PCB U004	D7580 or	C-DIODE	MA2J111	(1)	223279R2
PCB U004	D7580 or	C-DIODE	KDS4148U	(1)	223283R2
PCB U004	D7581	C-DIODE	ISS355	1	223269R2
PCB U004	D7581 or	C-DIODE	ISS352	(1)	223234R2
PCB U004	D7581 or	C-DIODE	MA2J111	(1)	223279R2
PCB U004	D7581 or	C-DIODE	KDS4148U	(1)	223283R2
PCB U004	D7582	C-DIODE	ISS355	1	223269R2
PCB U004	D7582 or	C-DIODE	ISS352	(1)	223234R2
PCB U004	D7582 or	C-DIODE	MA2J111	(1)	223279R2
PCB U004	D7582 or	C-DIODE	KDS4148U	(1)	223283R2
PCB U004	D7583	C-DIODE	ISS355	1	223269R2
PCB U004	D7583 or	C-DIODE	ISS352	(1)	223234R2
PCB U004	D7583 or	C-DIODE	MA2J111	(1)	223279R2
PCB U004	D7583 or	C-DIODE	KDS4148U	(1)	223283R2
PCB U004	D7592	LED	SLR-342MGTE7P	1	225455T
PCB U004	D7593	LED	SLR-342MGTE7P	1	225455T
PCB U004	D7595	LED	SLI-343URC-TE7	1	225449T
PCB U004	D9306	ZENER D	UDZS30B	1	224553000R2

PCB U004	D9310	ZENER D	UDZS16B	1	224551600R2
PCB U004	D9312	DIODE	RL1N4003	1	22380260T
PCB U004	D9313	DIODE	RL1N4003	1	22380260T
PCB U004	D9314	DIODE	RL1N4003	1	22380260T
PCB U004	D9315	DIODE	RL1N4003	1	22380260T
PCB U004	D9316	DIODE	RL1N4003	1	22380260T
PCB U004	Q7500	FL TUBE	HNA-16SL05T	1	212271A
PCB U004	Q7500A	HOLDER	(FL)	1	27191303
PCB U004	Q7501	IC	M66005-0001AHP	1	22242208R3
PCB U004	Q7502	IC	M66005-0001AHP	1	22242208R3
PCB U004	Q7503	TR	2SC2712-GR	1	2213145R2
PCB U004	Q7504	TR	2SC2712-GR	1	2213145R2
PCB U004	Q7530	IC	NJM4580M-D	1	22241448R2
PCB U004	Q7532	TR	RN1441	1	2215410R2
PCB U004	Q7533	TR	RN2403	1	2214540R2
PCB U004	Q7533 or	TR	KRA103S	(1)	2216230R2
PCB U004	Q7534	IC	NJM4580M-D	1	22241448R2
PCB U004	Q7540	TR	DTA123JKA	1	2214090R2
PCB U004	Q7592	TR	DTC123JKA	1	2216690R2
PCB U004	Q7593	TR	DTC123JKA	1	2216690R2
PCB U004	Q9301	TR	2SC2235-Y(TPE6_F)	1	2211654T
PCB U004	<b>[TRANS COIL]</b>				
PCB U004	L7520	CHOKE COIL	LBC2518T2R2M	1	231364M022R2
PCB U004	L7530	CHOKE COIL	LBC2518T2R2M	1	231364M022R2
PCB U004	L7580	CHOKE COIL	LBC2518T2R2M	1	231364M022R2
PCB U004	L7581	CHOKE COIL	LBC2518T2R2M	1	231364M022R2
PCB U004	L7582	CHOKE COIL	LBC2518T2R2M	1	231364M022R2
PCB U004	<b>[CAPACITOR]</b>				
PCB U004	C7501	C-CERA C	CK725B1H-223K1	1	332102235R1
PCB U004	C7502	C-CERA C	CK725F1E-104Z1	1	332161040R1
PCB U004	C7503	C-CERA C	CK725F1E-104Z1	1	332161040R1
PCB U004	C7504	C-CERA C	CK725B1H-473K1	1	332104735R1
PCB U004	C7505	C-CERA C	CK725B1H-473K1	1	332104735R1
PCB U004	C7506	ELECT C	CE04W50V-33M	1	355783309T
PCB U004	C7511	C-CERA C	CK725F1E-104Z1	1	332161040R1
PCB U004	C7512	C-CERA C	CC725CH1H-180J1	1	342101804R1
PCB U004	C7513	C-CERA C	CK725F1E-104Z1	1	332161040R1
PCB U004	C7514	C-CERA C	CK725F1E-104Z1	1	332161040R1
PCB U004	C7516	ELECT C	CE04W35V-47M	1	355764709T
PCB U004	C7518	C-CERA C	CK725F1E-104Z1	1	332161040R1
PCB U004	C7519	C-CERA C	CK725F1E-104Z1	1	332161040R1

PCB U004	C7520	C-CERA C	CK725B1H-223K1	1	332102235R1
PCB U004	C7521	UTSP C	CE04W10V-100M(UTSP)	1	397531017T
PCB U004	C7522	C-CERA C	CC725CH1H-221J1	1	342102214R1
PCB U004	C7523	C-CERA C	CC725CH1H-221J1	1	342102214R1
PCB U004	C7524	C-CERA C	CK725B1H-102K1	1	332101025R1
PCB U004	C7530	C-CERA C	CK725B1H-102K1	1	332101025R1
PCB U004	C7531	C-CERA C	CK725B1H-102K1	1	332101025R1
PCB U004	C7533	ELECT C	CE04W35V-47M	1	355764709T
PCB U004	C7534	ELECT C	CE04W16V-47M	1	355744709T
PCB U004	C7535	ELECT C	CE04W35V-10M(S)	1	353761009T
PCB U004	C7536	C-CERA C	CC725CH1H-101J1	1	342101014R1
PCB U004	C7537	C-CERA C	CC725CH1H-330J1	1	342103304R1
PCB U004	C7538	ELECT C	CE04W35V-10M(S)	1	353761009T
PCB U004	C7539	ELECT C	CE04W35V-10M(S)	1	353761009T
PCB U004	C7540	ELECT C	CE04W35V-10M(S)	1	353761009T
PCB U004	C7543	C-CERA C	CK725B1H-102K1	1	332101025R1
PCB U004	C7560	ELECT C	CE04W6.3V-220M	1	355722219T
PCB U004	C7561	C-CERA C	CK725B1H-102K1	1	332101025R1
PCB U004	C7562	C-CERA C	CK725B1H-102K1	1	332101025R1
PCB U004	C7580	MKT C	B32529C0102J289	1	376491024T
PCB U004	C7581	MKT C	B32529C0102J289	1	376491024T
PCB U004	C7582	MKT C	B32529C0102J289	1	376491024T
PCB U004	C7583	MKT C	B32529C0102J289	1	376491024T
PCB U004	C7590	C-CERA C	CK725B1H-103K1	1	332101035R1
PCB U004	C7591	C-CERA C	CK725B1H-103K1	1	332101035R1
PCB U004	C7900	C-CERA C	CK725FIE-104Z1	1	332161040R1
PCB U004	C9304	VR C	CE04W63V-220M(VR)	1	394672217T
PCB U004	C9305	VR C	CE04W63V-47M(VR)	1	394674707T
PCB U004	C9306	TF C	ECQ-V50V-223J	1	374722234T
PCB U004	[RESISTOR]				
PCB U004	R7500	C-CARBON R	RN72K1J-221JE	1	435032214R1
PCB U004	R7501	C-CARBON R	RN72K1J-221JE	1	435032214R1
PCB U004	R7502	C-CARBON R	RN72K1J-273JE	1	435032734R1
PCB U004	R7503	C-CARBON R	RN72K1J-222JE	1	435032224R1
PCB U004	R7504	C-CARBON R	RN72K1J-222JE	1	435032224R1
PCB U004	R7505	C-CARBON R	RN72K1J-222JE	1	435032224R1
PCB U004	R7506	C-CARBON R	RN72K1J-222JE	1	435032224R1
PCB U004	R7507	C-CARBON R	RN72K1J-222JE	1	435032224R1
PCB U004	R7508	C-CARBON R	RN72K1J-222JE	1	435032224R1
PCB U004	R7509	C-CARBON R	RN72K1J-222JE	1	435032224R1
PCB U004	R7510	C-CARBON R	RN72K1J-222JE	1	435032224R1



PCB U004	R7511	C-CARBON R	RN72K1J-000JE	1	435030004R1
PCB U004	R7512	C-CARBON R	RN72K1J-000JE	1	435030004R1
PCB U004	R7520	C-CARBON R	RN72K1J-221JE	1	435032214R1
PCB U004	R7521	C-CARBON R	RN72K1J-331JE	1	435033314R1
PCB U004	R7522	C-CARBON R	RN72K1J-331JE	1	435033314R1
PCB U004	R7523	C-CARBON R	RN72K1J-750JE	1	435037504R1
PCB U004	R7526	C-CARBON R	RN72K1J-223JE	1	435032234R1
PCB U004	R7527	C-CARBON R	RN72K1J-223JE	1	435032234R1
PCB U004	R7528	C-CARBON R	RN72K1J-224JE	1	435032244R1
PCB U004	R7529	C-CARBON R	RN72K1J-224JE	1	435032244R1
PCB U004	R7530	C-CARBON R	RN72K1J-472JE	1	435034724R1
PCB U004	R7531	C-CARBON R	RN72K1J-101JE	1	435031014R1
PCB U004	R7532	C-CARBON R	RN72K1J-331JE	1	435033314R1
PCB U004	R7533	C-CARBON R	RN72K1J-182JE	1	435031824R1
PCB U004	R7534	C-CARBON R	RN72K1J-104JE	1	435031044R1
PCB U004	R7535	C-CARBON R	RN72K1J-102JE	1	435031024R1
PCB U004	R7536	C-CARBON R	RN72K1J-333JE	1	435033334R1
PCB U004	R7537	C-CARBON R	RN72K1J-333JE	1	435033334R1
PCB U004	R7538	C-CARBON R	RN72K1J-221JE	1	435032214R1
PCB U004	R7539	C-CARBON R	RN72K1J-221JE	1	435032214R1
PCB U004	R7540	C-CARBON R	RN72K1J-473JE	1	435034734R1
PCB U004	R7541	C-CARBON R	RN72K1J-180JE	1	435031804R1
PCB U004	R7560	C-CARBON R	RN72K1J-102JE	1	435031024R1
PCB U004	R7561	C-CARBON R	RN72K1J-101JE	1	435031014R1
PCB U004	R7562	C-CARBON R	RN72K1J-105JE	1	435031054R1
PCB U004	R7580	METAL O R	RS1WBJ-33	1	443623304T
PCB U004	R7581	METAL O R	RS1WBJ-33	1	443623304T
PCB U004	R7590	C-CARBON R	RN72K1J-103JE	1	435031034R1
PCB U004	R7591	C-CARBON R	RN72K1J-103JE	1	435031034R1
PCB U004	R7592	C-CARBON R	RN72K1J-103JE	1	435031034R1
PCB U004	R7593	C-CARBON R	RN72K1J-103JE	1	435031034R1
PCB U004	R7596	C-CARBON R	RN72K1J-331JE	1	435033314R1
PCB U004	R7597	C-CARBON R	RN72K1J-331JE	1	435033314R1
PCB U004	R7599	C-CARBON R	RN72K1J-102JE	1	435031024R1
PCB U004	R7611	C-CARBON R	RN72K1J-271JE	1	435032714R1
PCB U004	R7612	C-CARBON R	RN72K1J-331JE	1	435033314R1
PCB U004	R7613	C-CARBON R	RN72K1J-471JE	1	435034714R1
PCB U004	R7614	C-CARBON R	RN72K1J-561JE	1	435035614R1
PCB U004	R7615	C-CARBON R	RN72K1J-821JE	1	435038214R1
PCB U004	R7616	C-CARBON R	RN72K1J-122JE	1	435031224R1
PCB U004	R7617	C-CARBON R	RN72K1J-222JE	1	435032224R1

PCB U004	R7618	C-CARBON R	RN72K1J-392JE	1	435033924R1
PCB U004	R7619	C-CARBON R	RN72K1J-123JE	1	435031234R1
PCB U004	R7621	C-CARBON R	RN72K1J-271JE	1	435032714R1
PCB U004	R7622	C-CARBON R	RN72K1J-331JE	1	435033314R1
PCB U004	R7623	C-CARBON R	RN72K1J-471JE	1	435034714R1
PCB U004	R7624	C-CARBON R	RN72K1J-561JE	1	435035614R1
PCB U004	R7625	C-CARBON R	RN72K1J-821JE	1	435038214R1
PCB U004	R7626	C-CARBON R	RN72K1J-122JE	1	435031224R1
PCB U004	R7627	C-CARBON R	RN72K1J-222JE	1	435032224R1
PCB U004	R7628	C-CARBON R	RN72K1J-392JE	1	435033924R1
PCB U004	R7629	C-CARBON R	RN72K1J-123JE	1	435031234R1
PCB U004	R7631	C-CARBON R	RN72K1J-271JE	1	435032714R1
PCB U004	R7632	C-CARBON R	RN72K1J-331JE	1	435033314R1
PCB U004	R7633	C-CARBON R	RN72K1J-471JE	1	435034714R1
PCB U004	R7634	C-CARBON R	RN72K1J-561JE	1	435035614R1
PCB U004	R7635	C-CARBON R	RN72K1J-821JE	1	435038214R1
PCB U004	R7636	C-CARBON R	RN72K1J-122JE	1	435031224R1
PCB U004	R7637	C-CARBON R	RN72K1J-222JE	1	435032224R1
PCB U004	R7638	C-CARBON R	RN72K1J-392JE	1	435033924R1
PCB U004	R7639	C-CARBON R	RN72K1J-123JE	1	435031234R1
PCB U004	R7641	C-CARBON R	RN72K1J-271JE	1	435032714R1
PCB U004	R7642	C-CARBON R	RN72K1J-331JE	1	435033314R1
PCB U004	R7643	C-CARBON R	RN72K1J-471JE	1	435034714R1
PCB U004	R7644	C-CARBON R	RN72K1J-561JE	1	435035614R1
PCB U004	R7645	C-CARBON R	RN72K1J-821JE	1	435038214R1
PCB U004	R7646	C-CARBON R	RN72K1J-122JE	1	435031224R1
PCB U004	R7647	C-CARBON R	RN72K1J-222JE	1	435032224R1
PCB U004	R7648	C-CARBON R	RN72K1J-392JE	1	435033924R1
PCB U004	R7649	C-CARBON R	RN72K1J-123JE	1	435031234R1
PCB U004	R7939	C-CARBON R	RN72K1J-104JE	1	435031044R1
PCB U004	R7954	C-CARBON R	RN72K1J-104JE	1	435031044R1
PCB U004	R9304	METAL O R	RS1/2WBJ-10	1	443521004T
PCB U004	R9305	C-CARBON R	RN72K1J-562JE	1	435035624R1
PCB U004	R9307	C-CARBON R	RN72K1J-333JE	1	435033334R1
PCB U004	R9308	METAL R	RNU1/2WCJ-1	1	453530104T
PCB U004	R9310	METAL O R	RS1/2WBJ-10	1	443521004T
PCB U004	[SW TRM]				
PCB U004	E7580	TRM	NTM-1P233(M1969)	1	25060302
PCB U004	E7601	TRM-423(SCREW)	NEJITANSI ST3	1	25060495
PCB U004	JL4103B	SOCKET	NSCT-5P97	1	25050269
PCB U004	JL7560A	WIRE HOL	NSCT-3P874	1	25051087

PCB U004	JL7560B	WIRE HOL	NSCT-3P874	1	25051087	
PCB U004	JL7562A	WIRE HOL	NSCT-3P874	1	25051087	
PCB U004	JL7562B	WIRE HOL	NSCT-3P874	1	25051087	
PCB U004	JL7591A	WIRE HOL	NSCT-5P896	1	25051109	
PCB U004	JL7591B	WIRE HOL	NSCT-5P896	1	25051109	
PCB U004	JL9303A	WIRE HOL	NSCT-5P876	1	25051089	
PCB U004	JL9303B	WIRE TRAP	NPLG-5P588	1	25055626	
PCB U004	P7501B	PLUG	A2545WR2-2x20P(IDE40SIDE)	1	25056643	
PCB U004	P7522	PIN JACK	NPJ-3PDB694	1	25045926	
PCB U004	P7530	ST JACK	MSJ-035-05C B AG GR type	1	25045880	
PCB U004	P7566	PWB	BCDIS-0121	1	25140121C	N
PCB U004	P7567	PWB	BCSW-0122	{ 1 }	25140122	
PCB U004	P7568	PWB	BCETC-0123	{ 1 }	25140123	
PCB U004	P7569	PWB	BCETC-0124	{ 1 }	25140124	
PCB U004	P7570	PWB	BCETC-0125	{ 1 }	25140125	
PCB U004	P7580	ST JACK	MSJ-064-05A GR	1	25045782	
PCB U004	P7581	PWB	BCPS-0126	{ 1 }	25140126	
PCB U004	P7582	PWB	BCETC-0127	{ 1 }	25140127	
PCB U004	P7583	PWB	BCETC-0128	{ 1 }	25140128	
PCB U004	P7584	PWB	BCETC-0129	{ 1 }	25140129	
PCB U004	P7585	PWB	BCETC-0130	{ 1 }	25140130	
PCB U004	P7590A	SOCKET AS	NSAS-22P1061	1	2002A392205	
PCB U004	P7590B	PLUG	NPLG-11P139	1	25055155	
PCB U004	P7599A	SOCKET AS	NSAS-7P1800	1	2002A391405UL	
PCB U004	P7599B	PLUG	NPLG-7P135	1	25055151	
PCB U004	P9301A	PLUG	NPLG-6P120	1	25055136	
PCB U004	S7590	R ENCODE	EVEHD1F3024B	1	25065695W	
PCB U004	S7611	PUSH SW	NPS-111-S681	1	25035718T	
PCB U004	S7612	PUSH SW	NPS-111-S681	1	25035718T	
PCB U004	S7613	PUSH SW	NPS-111-S681	1	25035718T	
PCB U004	S7614	PUSH SW	NPS-111-S681	1	25035718T	
PCB U004	S7615	PUSH SW	NPS-111-S681	1	25035718T	
PCB U004	S7616	PUSH SW	NPS-111-S681	1	25035718T	
PCB U004	S7617	PUSH SW	NPS-111-S681	1	25035718T	
PCB U004	S7618	PUSH SW	NPS-111-S681	1	25035718T	
PCB U004	S7619	PUSH SW	NPS-111-S681	1	25035718T	
PCB U004	S7620	PUSH SW	NPS-111-S681	1	25035718T	
PCB U004	S7621	PUSH SW	NPS-111-S681	1	25035718T	
PCB U004	S7622	PUSH SW	NPS-111-S681	1	25035718T	
PCB U004	S7623	PUSH SW	NPS-111-S681	1	25035718T	
PCB U004	S7624	PUSH SW	NPS-111-S681	1	25035718T	

PCB U004	S7625	PUSH SW	NPS-111-S681	1	25035718T	
PCB U004	S7626	PUSH SW	NPS-111-S681	1	25035718T	
PCB U004	S7627	PUSH SW	NPS-111-S681	1	25035718T	
PCB U004	S7628	PUSH SW	NPS-111-S681	1	25035718T	
PCB U004	S7629	PUSH SW	NPS-111-S681	1	25035718T	
PCB U004	S7630	PUSH SW	NPS-111-S681	1	25035718T	
PCB U004	S7631	PUSH SW	NPS-111-S681	1	25035718T	
PCB U004	S7632	PUSH SW	NPS-111-S681	1	25035718T	
PCB U004	S7633	PUSH SW	NPS-111-S681	1	25035718T	
PCB U004	S7634	PUSH SW	NPS-111-S681	1	25035718T	
PCB U004	S7635	PUSH SW	NPS-111-S681	1	25035718T	
PCB U004	S7636	PUSH SW	NPS-111-S681	1	25035718T	
PCB U004	S7637	PUSH SW	NPS-111-S681	1	25035718T	
PCB U004	S7638	PUSH SW	NPS-111-S681	1	25035718T	
PCB U004	S7639	PUSH SW	NPS-111-S681	1	25035718T	
PCB U004	S7640	PUSH SW	NPS-111-S681	1	25035718T	
PCB U004	S7641	PUSH SW	NPS-111-S681	1	25035718T	
PCB U004	S7642	PUSH SW	NPS-111-S681	1	25035718T	
PCB U004	S7643	PUSH SW	NPS-111-S681	1	25035718T	
PCB U004	S7644	PUSH SW	NPS-111-S681	1	25035718T	
PCB U004	S7645	PUSH SW	NPS-111-S681	1	25035718T	
PCB U004	S7646	PUSH SW	NPS-111-S681	1	25035718T	
PCB U004	S7647	PUSH SW	NPS-111-S681	1	25035718T	
PCB U004	S7648	PUSH SW	NPS-111-S681	1	25035718T	
PCB U004	S7650	PUSH SW	NPS-111-S681	1	25035718T	
PCB U004	[CHASSIS SCREW]					
PCB U004	D7570A	HOLDER	(LED)LH-5-5	1	27191312	
PCB U005	<b>U005</b> HDMI CIRCUIT PC BOARD (BAHDM-0132-1E)					
PCB U005						
PCB U005	<b>CIRCUIT. NO.</b>	<b>PART NAME</b>	<b>DESCRIPTION</b>	<b>Q'TY</b>	<b>PART NO. (SN)</b>	<b>REMARKS</b>
PCB U005	[SEMI CONDUCTOR]					
PCB U005	D3101	C-DIODE	KDS4148U	1	223283R2	
PCB U005	D3101 or	C-DIODE	1SS352	(1)	223234R2	
PCB U005	D3401	C-DIODE	KDS4148U	1	223283R2	
PCB U005	D3401 or	C-DIODE	1SS352	(1)	223234R2	
PCB U005	D8041	DIODE	RB070M-30	1	22380361R2	
PCB U005	D8043	DIODE	RB070M-30	1	22380361R2	
PCB U005	D8301	C-DIODE	1SS226(TE85L_F)	1	223266R2	
PCB U005	D8302	C-DIODE	KDS4148U	1	223283R2	
PCB U005	D8302 or	C-DIODE	1SS352	(1)	223234R2	

PCB U005	D8351	C-DIODE	1SS226(TE85L_F)	1	223266R2	
PCB U005	D8352	C-DIODE	KDS4148U	1	223283R2	
PCB U005	D8352 or	C-DIODE	1SS352	(1)	223234R2	
PCB U005	D8652	C-DIODE	1SR154-400	1	22380284R2	
PCB U005	D8653	C-DIODE	KDS4148U	1	223283R2	
PCB U005	D8653 or	C-DIODE	1SS352	(1)	223234R2	
PCB U005	D8701	C-DIODE	KDS4148U	1	223283R2	
PCB U005	D8701 or	C-DIODE	1SS352	(1)	223234R2	
PCB U005	D8801	C-DIODE	KDS4148U	1	223283R2	
PCB U005	D8801 or	C-DIODE	1SS352	(1)	223234R2	
PCB U005	D8951	DIODE	RSX501LA-20	1	22380364R2	
PCB U005	D8952	DIODE	RSX501LA-20	1	22380364R2	
PCB U005	D8953	DIODE	RSX501LA-20	1	22380364R2	
PCB U005	D8954	DIODE	RSX501LA-20	1	22380364R2	
PCB U005	D8958	C-DIODE	1SS352	1	223234R2	
PCB U005	D8958 or	C-DIODE	MA2J111	(1)	223279R2	
PCB U005	D8958 or	C-DIODE	KDS4148U	(1)	223283R2	
PCB U005	Q205	IC	TC74VHC157FT	1	22274157ER2TO	
PCB U005	Q3001	IC	D830K011AZKB300ZrevC	1	22242617R3	N
PCB U005	Q3002	IC (DSP)	NAND256W3A2BN6E (0309)	1	222W0092R303096	
PCB U005	Q3003	IC	IS42S16160C-7TL	1	22242592R3	
PCB U005	Q3003 or	IC	K4S561632J-UC75	(1)	22242524AR3	
PCB U005	Q3004	IC	IS42S16160C-7TL	1	22242592R3	
PCB U005	Q3004 or	IC	K4S561632J-UC75	(1)	22242524AR3	
PCB U005	Q3005	IC	TC7W32FU	1	22241162R2	
PCB U005	Q3006	IC	S-80127CNMC-JKM-T2	1	22241642R2	
PCB U005	Q3101	IC	TPD2E001DRLR	1	22242589R2	
PCB U005	Q3102	IC	MIC2005-0.5YM6	1	22242590R2	
PCB U005	Q3103	IC	BH18LB1WG-TR	1	22242562R2	
PCB U005	Q3106	IC	BH33FB1WG-TR	1	22242585R2	
PCB U005	Q3107	IC	BA33BC0FP	1	22278033DR2RH	
PCB U005	Q3107 or	IC	TA48033BF(TE16L_NQ)	(1)	22278033DBR2TO	
PCB U005	Q3107 or	IC	TA48033AF(TE16L_NQ)	(1)	22278033DR2TO	
PCB U005	Q3108	IC	KSZ8041NL	1	22242591R2	
PCB U005	Q3109	IC	BD7820	1	22242300R2	
PCB U005	Q3202	IC	TC74VHC157FT	1	22274157ER2TO	
PCB U005	Q3204	IC	TC7SZU04FU	1	22242512R2TO	
PCB U005	Q3205	IC	TC7SZU04FU	1	22242512R2TO	
PCB U005	Q3206	IC	NE5532APSR	1	22242283R2	
PCB U005	Q3207	IC	NE5532APSR	1	22242283R2	
PCB U005	Q3210	IC	TC7WH241FU(TE12L_F)	1	22242076R2TO	

PCB U005	Q3401	IC (DSP2)	ES29LV160ET-70TG (0324)	1	222W0069R303247	
PCB U005	Q3401 or	IC (DSP2)	S29AL016D70TFI010 (0324)	(1)	222W0063R303247	
PCB U005	Q3401 or	IC (DSP2)	S29AL016J70TFI010 (0324)	(1)	222W0100R303247	
PCB U005	Q3401 or	IC (DSP2)	MX29LV160DTTI-7 (0324)	(1)	222W0104R303247	
PCB U005	Q3402	IC	D788E001BRFP266Z	1	22242502R3	
PCB U005	Q3403	IC	K4S641632K-UC60	1	22242462R2	
PCB U005	Q3403 or	IC	K4S641632N-LC60	(1)	22242603R2	
PCB U005	Q3403 or	IC	EM638165TS-7G	(1)	22242607R2	
PCB U005	Q3404	IC	BD7820	1	22242300R2	
PCB U005	Q3405	IC	TC7WU04FU(TE12L_F)	1	22240935R2	
PCB U005	Q3406	IC	TA48033AF(TE16L_NQ)	1	22278033DR2TO	
PCB U005	Q3406 or	IC	TA48033BF(TE16L_NQ)	(1)	22278033DBR2TO	
PCB U005	Q3604	IC	PCM1754DBQR	1	22242598R2	
PCB U005	Q8000	IC	HY5DU561622ETP-4-C	1	22242450R3	
PCB U005	Q8000 or	IC	HY5DU561622FTP-4-C	(1)	22242577R3	
PCB U005	Q8001	IC	HY5DU561622ETP-4-C	1	22242450R3	
PCB U005	Q8001 or	IC	HY5DU561622FTP-4-C	(1)	22242577R3	
PCB U005	Q8005	IC (VSP)	MX29LV320CTTC-70G (0311)	1	222W0052R30311A	
PCB U005	Q8005 or	IC (VSP)	MX29LV320DTTI-70G (0311)	(1)	222W0109R30311A	N
PCB U005	Q8041	IC	TA48018BF(TE16L_NQ)	1	22278018DBR2TO	
PCB U005	Q8161	IC	TA48018BF(TE16L_NQ)	1	22278018DBR2TO	
PCB U005	Q8162	IC	SIH9185ACTU	1	22242471R3	
PCB U005	Q8200	IC	FLI30336	1	22242469R3	
PCB U005	Q8201	IC	BR24S32FJ-WE2	1	22242569R2	
PCB U005	Q8201 or	IC	24LC32A-I/SN	(1)	22242521R2	
PCB U005	Q8287	IC	MK2302S-01LFTR	1	22242552R2	
PCB U005	Q8305	IC	S-812C50BUC-C5ET2G	1	22242407R2	
PCB U005	Q8306	IC	NC7SZ08P5X_F042	1	22242482R2	
PCB U005	Q8306 or	IC	TC7SZ08FU(TE85L_F)	(1)	22242071R2TO	
PCB U005	Q8309	TR ARRAY	UM6K1N	1	226066R2	
PCB U005	Q8355	IC	S-812C50BUC-C5ET2G	1	22242407R2	
PCB U005	Q8356	IC	NC7SZ08P5X_F042	1	22242482R2	
PCB U005	Q8356 or	IC	TC7SZ08FU(TE85L_F)	(1)	22242071R2TO	
PCB U005	Q8359	TR ARRAY	UM6K1N	1	226066R2	
PCB U005	Q8362	IC	SIH9185ACTU	1	22242471R3	
PCB U005	Q8401	IC	SIH9134CTU	1	22242394R3	
PCB U005	Q8404	IC	BH18LB1WG-TR	1	22242562R2	
PCB U005	Q8405	IC	SN74CB3Q3305PWR	1	22242258R2	
PCB U005	Q8451	IC	SIH9134CTU	1	22242394R3	
PCB U005	Q8454	IC	BH18LB1WG-TR	1	22242562R2	
PCB U005	Q8501	IC	SIH9233ACTU	1	22242582R3	

PCB U005	Q8595	IC	TA48018BF(TE16L_NQ)	1	22278018DBR2TO	
PCB U005	Q8652	IC	BH33FB1WG-TR	1	22242585R2	
PCB U005	Q8654	IC	BD7820	1	22242300R2	
PCB U005	Q8701	IC (HDMI/VIDEO)	MPD70F3739GC-UEU-AX (0299)	1	222W0102R302995	N
PCB U005	Q8801	IC	ADV7342BSTZ-3	1	22242608R3	
PCB U005	Q8802	IC	BH18LB1WG-TR	1	22242562R2	
PCB U005	Q8803	TR	DTC144EE	1	2216390R2	
PCB U005	Q8803 or	TR	KRC404E	(1)	2216450R2	
PCB U005	Q8813	IC	TC74VCX162827	1	22242395R2	
PCB U005	Q8814	IC	TC74VCX162827	1	22242395R2	
PCB U005	Q8817	IC	TC74VCX162827	1	22242395R2	
PCB U005	Q8818	IC	TC74VCX162827	1	22242395R2	
PCB U005	Q8951	IC	MP1593DN	1	22242601R2	N
PCB U005	Q8952	IC	MP1593DN	1	22242601R2	N
PCB U005	Q8953	IC	MP1593DN	1	22242601R2	N
PCB U005	Q8954	IC	MP1593DN	1	22242601R2	N
PCB U005	Q8955	TR	DTC144EE	1	2216390R2	
PCB U005	Q8955 or	TR	KRC404E	(1)	2216450R2	
PCB U005	Q8956	TR	DTC144EE	1	2216390R2	
PCB U005	Q8956 or	TR	KRC404E	(1)	2216450R2	
PCB U005	Q8957	TR	DTC144EE	1	2216390R2	
PCB U005	Q8957 or	TR	KRC404E	(1)	2216450R2	
PCB U005	Q8958	TR	DTC144EE	1	2216390R2	
PCB U005	Q8958 or	TR	KRC404E	(1)	2216450R2	
PCB U005	Q8963	TR	DTC144EE	1	2216390R2	
PCB U005	Q8963 or	TR	KRC404E	(1)	2216450R2	
PCB U005	<b>[TRANS COIL]</b>					
PCB U005	L251	CORE	BLM18PG181SN1D	1	2350005R1	
PCB U005	L261	EMIFIL	BK1608LM182-T	1	230958R1	
PCB U005	L3001	CORE	BLM18PG121SN1D	1	2350006R1	
PCB U005	L3002	CORE	BLM18PG121SN1D	1	2350006R1	
PCB U005	L3003	CORE	BLM18PG121SN1D	1	2350006R1	
PCB U005	L3004	CORE	BLM18PG121SN1D	1	2350006R1	
PCB U005	L3005	CORE	BLM18PG121SN1D	1	2350006R1	
PCB U005	L3102	CORE	BLM18PG181SN1D	1	2350005R1	
PCB U005	L3103	CORE	BLM18PG121SN1D	1	2350006R1	
PCB U005	L3104	CORE	BLM18PG121SN1D	1	2350006R1	
PCB U005	L3105	CORE	BLM18PG121SN1D	1	2350006R1	
PCB U005	L3106	CORE	BLM18PG121SN1D	1	2350006R1	
PCB U005	L3107	CORE	BLM18PG121SN1D	1	2350006R1	
PCB U005	L3108	CORE	BLM18PG121SN1D	1	2350006R1	

PCB U005	L3109	CORE	BLM18PG121SN1D	1	2350006R1
PCB U005	L3110	CORE	BLM18PG121SN1D	1	2350006R1
PCB U005	L3202	C-CARBON R	RN72K1J-000JE	1	435030004R1
PCB U005	L3203	CORE	MMZ1608Y601BT	1	2350004R1
PCB U005	L3204	CORE	MMZ1608Y601BT	1	2350004R1
PCB U005	L3205	CORE	BLM18PG121SN1D	1	2350006R1
PCB U005	L3206	CORE	BLM18PG121SN1D	1	2350006R1
PCB U005	L3207	CORE	MMZ1608Y601BT	1	2350004R1
PCB U005	L3208	CORE	MMZ1608Y601BT	1	2350004R1
PCB U005	L3209	CORE	MMZ1608Y601BT	1	2350004R1
PCB U005	L3401	C-CARBON R	RN72K1J-000JE	1	435030004R1
PCB U005	L3402	CORE	BLM18PG121SN1D	1	2350006R1
PCB U005	L3403	CORE	MMZ1608Y601BT	1	2350004R1
PCB U005	L3405	CORE	BLM18PG121SN1D	1	2350006R1
PCB U005	L3406	CORE	BLM18PG121SN1D	1	2350006R1
PCB U005	L3407	CORE	BLM18PG121SN1D	1	2350006R1
PCB U005	L3408	CORE	BLM18PG121SN1D	1	2350006R1
PCB U005	L3409	CORE	BLM18PG121SN1D	1	2350006R1
PCB U005	L3410	CORE	MMZ1608Y601BT	1	2350004R1
PCB U005	L3411	CORE	MMZ1608Y601BT	1	2350004R1
PCB U005	L3509	CHOKE COIL	LBC2518T470M	1	231364M470R2
PCB U005	L8021	CHOKE COIL	BLM21PG221SN1	1	230949R2
PCB U005	L8022	CHOKE COIL	BLM21PG221SN1	1	230949R2
PCB U005	L8023	CHOKE COIL	BLM21PG221SN1	1	230949R2
PCB U005	L8024	CHOKE COIL	BLM21PG221SN1	1	230949R2
PCB U005	L8025	CHOKE COIL	BLM21PG221SN1	1	230949R2
PCB U005	L8026	CHOKE COIL	BLM21PG221SN1	1	230949R2
PCB U005	L8027	CHOKE COIL	BLM21PG221SN1	1	230949R2
PCB U005	L8041	CHOKE COIL	BLM21PG221SN1	1	230949R2
PCB U005	L8042	CHOKE COIL	BLM21PG221SN1	1	230949R2
PCB U005	L8043	CHOKE COIL	BLM21PG221SN1	1	230949R2
PCB U005	L8161	CORE	BLM18PG181SN1D	1	2350005R1
PCB U005	L8162	CORE	BLM18PG181SN1D	1	2350005R1
PCB U005	L8163	CORE	BLM18PG181SN1D	1	2350005R1
PCB U005	L8361	CORE	BLM18PG181SN1D	1	2350005R1
PCB U005	L8362	CORE	BLM18PG181SN1D	1	2350005R1
PCB U005	L8363	CORE	BLM18PG181SN1D	1	2350005R1
PCB U005	L8401	CORE	BLM18PG181SN1D	1	2350005R1
PCB U005	L8402	CORE	BLM18PG181SN1D	1	2350005R1
PCB U005	L8403	CORE	BLM18PG181SN1D	1	2350005R1
PCB U005	L8404	CORE	BLM18PG181SN1D	1	2350005R1



PCB U005	L8405	CORE	BLM18PG181SN1D	1	2350005R1
PCB U005	L8406	C-R NET	MNR12E0APJ000	1	43464900002R2
PCB U005	L8407	C-R NET	MNR12E0APJ000	1	43464900002R2
PCB U005	L8408	CORE	BLM18PG181SN1D	1	2350005R1
PCB U005	L8409	C-R NET	MNR12E0APJ000	1	43464900002R2
PCB U005	L8410	C-R NET	MNR12E0APJ000	1	43464900002R2
PCB U005	L8450	C-R NET	MNR12E0APJ000	1	43464900002R2
PCB U005	L8451	CORE	BLM18PG181SN1D	1	2350005R1
PCB U005	L8452	CORE	BLM18PG181SN1D	1	2350005R1
PCB U005	L8453	CORE	BLM18PG181SN1D	1	2350005R1
PCB U005	L8454	CORE	BLM18PG181SN1D	1	2350005R1
PCB U005	L8455	CORE	BLM18PG181SN1D	1	2350005R1
PCB U005	L8456	C-R NET	MNR12E0APJ000	1	43464900002R2
PCB U005	L8457	C-R NET	MNR12E0APJ000	1	43464900002R2
PCB U005	L8458	CORE	BLM18PG181SN1D	1	2350005R1
PCB U005	L8459	C-R NET	MNR12E0APJ000	1	43464900002R2
PCB U005	L8601	CORE	BLM18PG181SN1D	1	2350005R1
PCB U005	L8602	CORE	BLM18PG181SN1D	1	2350005R1
PCB U005	L8603	CORE	BLM18PG181SN1D	1	2350005R1
PCB U005	L8604	CORE	BLM18PG181SN1D	1	2350005R1
PCB U005	L8605	CORE	BLM18PG181SN1D	1	2350005R1
PCB U005	L8606	CORE	BLM18PG181SN1D	1	2350005R1
PCB U005	L8608	EMIFIL	BK1608LM182-T	1	230958R1
PCB U005	L8641	CORE	BLM18PG181SN1D	1	2350005R1
PCB U005	L8701	CORE	BLM18PG181SN1D	1	2350005R1
PCB U005	L8801	CHOKE COIL	LBC2518T4R7M	1	231364M047R2
PCB U005	L8802	CHOKE COIL	LBC2518T4R7M	1	231364M047R2
PCB U005	L8803	CHOKE COIL	LBC2518T4R7M	1	231364M047R2
PCB U005	L8804	CHOKE COIL	LBC2518T4R7M	1	231364M047R2
PCB U005	L8851	C-CARBON R	RN72K2B-000JE	1	433220004R1
PCB U005	L8852	C-CARBON R	RN72K2B-000JE	1	433220004R1
PCB U005	L8853	C-CARBON R	RN72K2B-000JE	1	433220004R1
PCB U005	L8854	C-CARBON R	RN72K2B-000JE	1	433220004R1
PCB U005	L8855	C-CARBON R	RN72K2B-000JE	1	433220004R1
PCB U005	L8856	C-CARBON R	RN72K2B-000JE	1	433220004R1
PCB U005	L8951	CHOKE COIL	0182-7E08Q-100M-RA	1	231396M100R2
PCB U005	L8952	CHOKE COIL	0182-7E08Q-6R8N-RA	1	231395P068R2
PCB U005	L8953	CHOKE COIL	0182-7E08Q-6R8N-RA	1	231395P068R2
PCB U005	L8954	CHOKE COIL	0182-7E08Q-100M-RA	1	231396M100R2
PCB U005	L8955	CHOKE COIL	BLM21PG221SN1	1	230949R2
PCB U005	L8956	CHOKE COIL	BLM21PG221SN1	1	230949R2

PCB U005	L8957	CHOKE COIL	BLM21PG221SN1	1	230949R2	
PCB U005	L8958	CHOKE COIL	BLM21PG221SN1	1	230949R2	
PCB U005	L8959	CHOKE COIL	BLM21PG221SN1	1	230949R2	
PCB U005	L8960	CHOKE COIL	BLM21PG221SN1	1	230949R2	
PCB U005	L8961	CHOKE COIL	BLM21PG221SN1	1	230949R2	
PCB U005	L8962	CHOKE COIL	BLM21PG221SN1	1	230949R2	
PCB U005	L8963	CHOKE COIL	BLM21PG221SN1	1	230949R2	
PCB U005	L8964	CHOKE COIL	BLM21PG221SN1	1	230949R2	
PCB U005	L8965	CHOKE COIL	BLM21PG221SN1	1	230949R2	
PCB U005	L8966	CHOKE COIL	BLM21PG221SN1	1	230949R2	
PCB U005	X3001	CRYSTAL	HC-49SMD24.000MHz	1	3010479R2	
PCB U005	X3001 or	CRYSTAL	HC-49USSMD24.00MHz	( 1)	3010471R2	
PCB U005	X3201	CRYSTAL	HC-49/U03C 12.288MHz	1	3010323R2	
PCB U005	X3202	CRYSTAL	HC-49SMD11.2896MHz	1	3010480R2	
PCB U005	X3202 or	CRYSTAL	HC-49USSMD11.2896MHz	( 1)	3010472R2	
PCB U005	X3401	CRYSTAL	HC-49USSMD17.734MHz	1	3010442R2	
PCB U005	X8200	CRYSTAL	HC-49USSMD19.6608M	1	3010458R2	
PCB U005	X8501	CRYSTAL	DSX530GAK27.0000MHZ	1	3010474R2	N
PCB U005	X8701	CERA LOCK	CSTCR5M00G53-B0	1	3010356R2	
PCB U005	<b>[CAPACITOR]</b>					
PCB U005	C251	C-CERA C	CK725F1A-105Z1	1	332181050R1	
PCB U005	C252	C-CERA C	CK725F1A-105Z1	1	332181050R1	
PCB U005	C3001	C-CERA C	CK725F1A-105Z1	1	332181050R1	
PCB U005	C3002	C-CERA C	CK725F1A-105Z1	1	332181050R1	
PCB U005	C3003	C-CERA C	CK725B0J-106K	1	332091065R2	
PCB U005	C3004	C-CERA C	CK725B0J-106K	1	332091065R2	
PCB U005	C3005	C-CERA C	CK725F1A-105Z1	1	332181050R1	
PCB U005	C3006	C-CERA C	CC725CH1H-102J1	1	342101024R1	
PCB U005	C3007	C-CERA C	CK725F1A-105Z1	1	332181050R1	
PCB U005	C3008	C-CERA C	CC725CH1H-102J1	1	342101024R1	
PCB U005	C3009	C-CERA C	CK725F1A-105Z1	1	332181050R1	
PCB U005	C3010	C-CERA C	CK725F1A-105Z1	1	332181050R1	
PCB U005	C3011	C-CERA C	CK725F1A-105Z1	1	332181050R1	
PCB U005	C3012	C-CERA C	CC725CH1H-102J1	1	342101024R1	
PCB U005	C3013	C-CERA C	CK725F1A-105Z1	1	332181050R1	
PCB U005	C3014	C-CERA C	CC725CH1H-102J1	1	342101024R1	
PCB U005	C3015	C-CERA C	CC725CH1H-102J1	1	342101024R1	
PCB U005	C3016	C-CERA C	CK725F1A-105Z1	1	332181050R1	
PCB U005	C3017	C-CERA C	CK725F1A-105Z1	1	332181050R1	
PCB U005	C3018	C-CERA C	CK725F1A-105Z1	1	332181050R1	
PCB U005	C3019	C-CERA C	CC725CH1H-102J1	1	342101024R1	

PCB U005	C3020	C-CERA C	CK725F1A-105Z1	1	332181050R1
PCB U005	C3021	C-CERA C	CK725F1A-105Z1	1	332181050R1
PCB U005	C3022	C-CERA C	CK725F1A-105Z1	1	332181050R1
PCB U005	C3023	C-CERA C	CK725B0J-106K	1	332091065R2
PCB U005	C3024	C-CERA C	CC725CH1H-102J1	1	342101024R1
PCB U005	C3025	C-CERA C	CK725F1A-105Z1	1	332181050R1
PCB U005	C3026	C-CERA C	CK725B1C-104K1	1	332121045R1
PCB U005	C3027	C-CERA C	CC725CH1H-102J1	1	342101024R1
PCB U005	C3028	C-CERA C	CK725F1A-105Z1	1	332181050R1
PCB U005	C3029	C-CERA C	CC725CH1H-102J1	1	342101024R1
PCB U005	C3030	C-CERA C	CK725F1A-105Z1	1	332181050R1
PCB U005	C3031	C-CERA C	CK725F1A-105Z1	1	332181050R1
PCB U005	C3032	C-CERA C	CC725CH1H-102J1	1	342101024R1
PCB U005	C3033	C-CERA C	CK725F1A-105Z1	1	332181050R1
PCB U005	C3034	C-CERA C	CC725CH1H-120J1	1	342101204R1
PCB U005	C3035	C-CERA C	CC725CH1H-102J1	1	342101024R1
PCB U005	C3036	C-CERA C	CC725CH1H-120J1	1	342101204R1
PCB U005	C3037	C-CERA C	CK725F1A-105Z1	1	332181050R1
PCB U005	C3038	C-CERA C	CK725F1A-105Z1	1	332181050R1
PCB U005	C3039	C-CERA C	CK725B1H-103K1	1	332101035R1
PCB U005	C3040	C-CERA C	CK725F1A-105Z1	1	332181050R1
PCB U005	C3041	C-CERA C	CK725B0J-106K	1	332091065R2
PCB U005	C3042	C-CERA C	CK725F1A-105Z1	1	332181050R1
PCB U005	C3043	C-CERA C	CK725F1A-105Z1	1	332181050R1
PCB U005	C3101	CHIP ELECT C	CEWX16V-100M	1	398141017R2
PCB U005	C3102	CHIP ELECT C	CEWX10V-220M	1	398132217R2
PCB U005	C3103	C-CERA C	CC725CH1H-102J1	1	342101024R1
PCB U005	C3104	C-CERA C	CK725F1A-105Z1	1	332181050R1
PCB U005	C3105	C-CERA C	CK725F1A-105Z1	1	332181050R1
PCB U005	C3106	C-CERA C	CK725B0J-106K	1	332091065R2
PCB U005	C3107	C-CERA C	CK725F1A-105Z1	1	332181050R1
PCB U005	C3108	C-CERA C	CK725F1A-105Z1	1	332181050R1
PCB U005	C3109	C-CERA C	CK725B0J-106K	1	332091065R2
PCB U005	C3110	C-CERA C	CK725B1A-224K1	1	332132245R1
PCB U005	C3112	C-CERA C	CK725B0J-106K	1	332091065R2
PCB U005	C3113	C-CERA C	CK725F1A-105Z1	1	332181050R1
PCB U005	C3114	C-CERA C	CK725F1A-105Z1	1	332181050R1
PCB U005	C3115	C-CERA C	CK725B0J-106K	1	332091065R2
PCB U005	C3116	C-CERA C	CK725B0J-106K	1	332091065R2
PCB U005	C3117	C-CERA C	CC725CH1H-102J1	1	342101024R1
PCB U005	C3118	C-CERA C	CK725F1A-105Z1	1	332181050R1

PCB U005	C3119	C-CERA C	CK725F1A-105Z1	1	332181050R1
PCB U005	C3120	C-CERA C	CK725B0J-106K	1	332091065R2
PCB U005	C3121	C-CERA C	CK725F1A-105Z1	1	332181050R1
PCB U005	C3122	C-CERA C	CK725F1A-105Z1	1	332181050R1
PCB U005	C3123	CHIP ELECT C	CEWX10V-220M	1	398132217R2
PCB U005	C3124	C-CERA C	CK725F1A-105Z1	1	332181050R1
PCB U005	C3125	C-CERA C	CK725B0J-106K	1	332091065R2
PCB U005	C3126	C-CERA C	CK725B0J-106K	1	332091065R2
PCB U005	C3127	C-CERA C	CK725F1A-105Z1	1	332181050R1
PCB U005	C3128	C-CERA C	CK725F1A-105Z1	1	332181050R1
PCB U005	C3129	C-CERA C	CK725F1A-105Z1	1	332181050R1
PCB U005	C3130	C-CERA C	CK725B0J-106K	1	332091065R2
PCB U005	C3131	C-CERA C	CK725F1A-105Z1	1	332181050R1
PCB U005	C3132	C-CERA C	CC725CH1H-101J1	1	342101014R1
PCB U005	C3133	C-CERA C	CK725F1A-105Z1	1	332181050R1
PCB U005	C3134	C-CERA C	CK725B1C-104K1	1	332121045R1
PCB U005	C3135	C-CERA C	CK725B1C-104K1	1	332121045R1
PCB U005	C3136	C-CERA C	CK725F1A-105Z1	1	332181050R1
PCB U005	C3137	C-CERA C	CK725F1A-105Z1	1	332181050R1
PCB U005	C3138	C-CERA C	CK725F1A-105Z1	1	332181050R1
PCB U005	C3139	C-CERA C	CK725F1A-105Z1	1	332181050R1
PCB U005	C3140	C-CERA C	CK725F1A-105Z1	1	332181050R1
PCB U005	C3143	C-CERA C	CK725F1A-105Z1	1	332181050R1
PCB U005	C3144	C-CERA C	CK725F1A-105Z1	1	332181050R1
PCB U005	C3145	C-CERA C	CK725B0J-106K	1	332091065R2
PCB U005	C3146	C-CERA C	CK725F1A-105Z1	1	332181050R1
PCB U005	C3147	C-CERA C	CK725B0J-106K	1	332091065R2
PCB U005	C3148	C-CERA C	CK725B1H-223K1	1	332102235R1
PCB U005	C3149	C-CERA C	CK725F1A-105Z1	1	332181050R1
PCB U005	C3150	CHIP ELECT C	CEWX4V-22M	1	3981G2207R2
PCB U005	C3151	C-CERA C	CK725B1H-103K1	1	332101035R1
PCB U005	C3152	C-CERA C	CK725B0J-106K	1	332091065R2
PCB U005	C3153	C-CERA C	CK725F1A-105Z1	1	332181050R1
PCB U005	C3154	C-CERA C	CK725B0J-106K	1	332091065R2
PCB U005	C3155	C-CERA C	CK725F1A-105Z1	1	332181050R1
PCB U005	C3156	C-CERA C	CC725CH1H-102J1	1	342101024R1
PCB U005	C3157	C-CERA C	CK725F1A-105Z1	1	332181050R1
PCB U005	C3158	C-CERA C	CK725F1A-105Z1	1	332181050R1
PCB U005	C3159	C-CERA C	CK725F1A-105Z1	1	332181050R1
PCB U005	C3202	C-CERA C	CK725F1A-105Z1	1	332181050R1
PCB U005	C3204	C-CERA C	CK725B0J-106K	1	332091065R2

PCB U005	C3205	C-CERA C	CK725F1A-105Z1	1	332181050R1
PCB U005	C3206	C-CERA C	CK725F1A-105Z1	1	332181050R1
PCB U005	C3207	C-CERA C	CK725B0J-106K	1	332091065R2
PCB U005	C3208	C-CERA C	CK725F1A-105Z1	1	332181050R1
PCB U005	C3209	C-CERA C	CK725F1A-105Z1	1	332181050R1
PCB U005	C3210	CHIP ELECT C	CEWX16V-100M	1	398141017R2
PCB U005	C3211	C-CERA C	CK725B1H-222K1	1	332102225R1
PCB U005	C3213	C-CERA C	CK725F1A-105Z1	1	332181050R1
PCB U005	C3214	C-CERA C	CK725B0J-106K	1	332091065R2
PCB U005	C3215	CHIP ELECT C	CEWX16V-10M	1	398141007R2
PCB U005	C3216	C-CERA C	CC725CH1H-120J1	1	342101204R1
PCB U005	C3219	C-CERA C	CC725CH1H-120J1	1	342101204R1
PCB U005	C3220	C-CERA C	CC725CH1H-120J1	1	342101204R1
PCB U005	C3223	C-CERA C	CC725CH1H-120J1	1	342101204R1
PCB U005	C3224	C-CERA C	CK725B1H-152K1	1	332101525R1
PCB U005	C3225	C-CERA C	CK725B1H-152K1	1	332101525R1
PCB U005	C3226	C-CERA C	CK725F1A-105Z1	1	332181050R1
PCB U005	C3227	CHIP ELECT C	CEWX16V-10M	1	398141007R2
PCB U005	C3228	C-CERA C	CK725B1H-222K1	1	332102225R1
PCB U005	C3229	C-CERA C	CK725F1A-105Z1	1	332181050R1
PCB U005	C3230	C-CERA C	CK725B0J-106K	1	332091065R2
PCB U005	C3231	C-CERA C	CK725F1A-105Z1	1	332181050R1
PCB U005	C3233	CHIP ELECT C	CEWX16V-100M	1	398141017R2
PCB U005	C3402	C-CERA C	CK725F1A-105Z1	1	332181050R1
PCB U005	C3403	C-CERA C	CK725F1A-105Z1	1	332181050R1
PCB U005	C3404	C-CERA C	CK725F1A-105Z1	1	332181050R1
PCB U005	C3405	C-CERA C	CK725F1A-105Z1	1	332181050R1
PCB U005	C3406	C-CERA C	CK725F1A-105Z1	1	332181050R1
PCB U005	C3407	C-CERA C	CK725F1A-105Z1	1	332181050R1
PCB U005	C3408	C-CERA C	CK725F1A-105Z1	1	332181050R1
PCB U005	C3409	C-CERA C	CK725F1A-105Z1	1	332181050R1
PCB U005	C3410	C-CERA C	CK725F1A-105Z1	1	332181050R1
PCB U005	C3412	C-CERA C	CK725F1A-105Z1	1	332181050R1
PCB U005	C3413	C-CERA C	CK725F1A-105Z1	1	332181050R1
PCB U005	C3414	C-CERA C	CC725CH1H-102J1	1	342101024R1
PCB U005	C3415	C-CERA C	CK725F1A-105Z1	1	332181050R1
PCB U005	C3416	C-CERA C	CK725F1A-105Z1	1	332181050R1
PCB U005	C3417	C-CERA C	CK725F1A-105Z1	1	332181050R1
PCB U005	C3418	C-CERA C	CK725F1A-105Z1	1	332181050R1
PCB U005	C3419	C-CERA C	CK725F1A-105Z1	1	332181050R1
PCB U005	C3420	C-CERA C	CK725B0J-106K	1	332091065R2

PCB U005	C3421	C-CERA C	CK725F1A-105Z1	1	332181050R1
PCB U005	C3422	C-CERA C	CK725F1A-105Z1	1	332181050R1
PCB U005	C3423	C-CERA C	CK725F1A-105Z1	1	332181050R1
PCB U005	C3424	C-CERA C	CK725F1A-105Z1	1	332181050R1
PCB U005	C3425	C-CERA C	CK725F1A-105Z1	1	332181050R1
PCB U005	C3426	C-CERA C	CK725F1A-105Z1	1	332181050R1
PCB U005	C3427	C-CERA C	CK725F1A-105Z1	1	332181050R1
PCB U005	C3428	C-CERA C	CK725F1A-105Z1	1	332181050R1
PCB U005	C3429	C-CERA C	CK725F1A-105Z1	1	332181050R1
PCB U005	C3430	C-CERA C	CK725F1A-105Z1	1	332181050R1
PCB U005	C3431	C-CERA C	CK725F1A-105Z1	1	332181050R1
PCB U005	C3432	C-CERA C	CK725F1A-105Z1	1	332181050R1
PCB U005	C3433	C-CERA C	CK725F1A-105Z1	1	332181050R1
PCB U005	C3434	C-CERA C	CK725F1A-105Z1	1	332181050R1
PCB U005	C3435	C-CERA C	CK725F1A-105Z1	1	332181050R1
PCB U005	C3436	C-CERA C	CK725F1A-105Z1	1	332181050R1
PCB U005	C3437	C-CERA C	CK725F1A-105Z1	1	332181050R1
PCB U005	C3438	C-CERA C	CK725F1A-105Z1	1	332181050R1
PCB U005	C3439	C-CERA C	CK725F1A-105Z1	1	332181050R1
PCB U005	C3440	C-CERA C	CK725F1A-105Z1	1	332181050R1
PCB U005	C3441	C-CERA C	CK725F1A-105Z1	1	332181050R1
PCB U005	C3442	C-CERA C	CK725B0J-106K	1	332091065R2
PCB U005	C3443	C-CERA C	CK725F1A-105Z1	1	332181050R1
PCB U005	C3444	C-CERA C	CC725CH1H-102J1	1	342101024R1
PCB U005	C3445	C-CERA C	CK725F1A-105Z1	1	332181050R1
PCB U005	C3446	C-CERA C	CK725B0J-106K	1	332091065R2
PCB U005	C3447	C-CERA C	CK725B0J-106K	1	332091065R2
PCB U005	C3448	C-CERA C	CK725B0J-106K	1	332091065R2
PCB U005	C3449	C-CERA C	CK725F1A-105Z1	1	332181050R1
PCB U005	C3450	C-CERA C	CK725F1A-105Z1	1	332181050R1
PCB U005	C3451	C-CERA C	CK725F1A-105Z1	1	332181050R1
PCB U005	C3452	C-CERA C	CK725F1A-105Z1	1	332181050R1
PCB U005	C3453	CHIP ELECT C	CEWX4V-22M	1	3981G2207R2
PCB U005	C3454	C-CERA C	CK725B1H-103K1	1	332101035R1
PCB U005	C3455	C-CERA C	CK725F1A-105Z1	1	332181050R1
PCB U005	C3456	C-CERA C	CK725B0J-106K	1	332091065R2
PCB U005	C3457	C-CERA C	CK725F1A-105Z1	1	332181050R1
PCB U005	C3458	C-CERA C	CK725B0J-106K	1	332091065R2
PCB U005	C3459	C-CERA C	CK725F1A-105Z1	1	332181050R1
PCB U005	C3461	CHIP ELECT C	CEWX4V-220M	1	3981G2217R2
PCB U005	C3462	C-CERA C	CK725F1A-105Z1	1	332181050R1

PCB U005	C3463	C-CERA C	CC725CH1H-060D1	1	342100602R1
PCB U005	C3464	C-CERA C	CC725CH1H-060D1	1	342100602R1
PCB U005	C8000	CHIP TANTAL	TCSCS0J226MAAR	1	396522207R2
PCB U005	C8000 or	CHIP TANTAL	F93-6.3V-22M	(1)	395522207R2
PCB U005	C8001	C-CERA C	CK725F1E-104Z1	1	332161040R1
PCB U005	C8002	C-CERA C	CK725F1E-104Z1	1	332161040R1
PCB U005	C8003	CHIP TANTAL	TCSCS0J226MAAR	1	396522207R2
PCB U005	C8003 or	CHIP TANTAL	F93-6.3V-22M	(1)	395522207R2
PCB U005	C8004	CHIP TANTAL	TCSCS0J226MAAR	1	396522207R2
PCB U005	C8004 or	CHIP TANTAL	F93-6.3V-22M	(1)	395522207R2
PCB U005	C8005	C-CERA C	CK725B1H-103K1	1	332101035R1
PCB U005	C8006	C-CERA C	CK725F1A-105Z1	1	332181050R1
PCB U005	C8007	C-CERA C	CK725F1A-105Z1	1	332181050R1
PCB U005	C8008	C-CERA C	CK725F1A-105Z1	1	332181050R1
PCB U005	C8009	C-CERA C	CK725F1A-105Z1	1	332181050R1
PCB U005	C8010	C-CERA C	CK725F1A-105Z1	1	332181050R1
PCB U005	C8011	C-CERA C	CK725F1A-105Z1	1	332181050R1
PCB U005	C8012	C-CERA C	CK725F1A-105Z1	1	332181050R1
PCB U005	C8013	C-CERA C	CK725F1A-105Z1	1	332181050R1
PCB U005	C8014	C-CERA C	CK725F1A-105Z1	1	332181050R1
PCB U005	C8015	C-CERA C	CK725F1A-105Z1	1	332181050R1
PCB U005	C8016	C-CERA C	CK725F1A-105Z1	1	332181050R1
PCB U005	C8017	C-CERA C	CK725F1A-105Z1	1	332181050R1
PCB U005	C8018	C-CERA C	CK725F1A-105Z1	1	332181050R1
PCB U005	C8021	CHIP ELECT C	CEWX16V-100M	1	398141017R2
PCB U005	C8022	C-CERA C	CK725F1A-105Z1	1	332181050R1
PCB U005	C8023	CHIP ELECT C	CEWX4V-100M	1	3981G1017R2
PCB U005	C8026	CHIP ELECT C	CEWX4V-220M	1	3981G2217R2
PCB U005	C8030	CHIP TANTAL	TCSCS0J226MAAR	1	396522207R2
PCB U005	C8030 or	CHIP TANTAL	F93-6.3V-22M	(1)	395522207R2
PCB U005	C8031	C-CERA C	CK725F1E-104Z1	1	332161040R1
PCB U005	C8032	C-CERA C	CK725B1H-103K1	1	332101035R1
PCB U005	C8033	C-CERA C	CK725F1E-104Z1	1	332161040R1
PCB U005	C8034	CHIP TANTAL	TCSCS0J226MAAR	1	396522207R2
PCB U005	C8034 or	CHIP TANTAL	F93-6.3V-22M	(1)	395522207R2
PCB U005	C8041	CHIP ELECT C	CEWX16V-100M	1	398141017R2
PCB U005	C8042	C-CERA C	CK725F1E-104Z1	1	332161040R1
PCB U005	C8043	CHIP ELECT C	CEWX4V-220M	1	3981G2217R2
PCB U005	C8044	CHIP ELECT C	CEWX4V-220M	1	3981G2217R2
PCB U005	C8051	C-CERA C	CK725F1E-104Z1	1	332161040R1
PCB U005	C8052	C-CERA C	CK725F1E-104Z1	1	332161040R1

PCB U005	C8053	C-CERA C	CK725F1E-104Z1	1	332161040R1
PCB U005	C8054	C-CERA C	CK725F1E-104Z1	1	332161040R1
PCB U005	C8055	C-CERA C	CK725F1E-104Z1	1	332161040R1
PCB U005	C8056	C-CERA C	CK725F1E-104Z1	1	332161040R1
PCB U005	C8057	C-CERA C	CK725F1E-104Z1	1	332161040R1
PCB U005	C8058	C-CERA C	CK725F1E-104Z1	1	332161040R1
PCB U005	C8059	C-CERA C	CK725F1E-104Z1	1	332161040R1
PCB U005	C8060	C-CERA C	CK725F1E-104Z1	1	332161040R1
PCB U005	C8061	C-CERA C	CK725F1E-104Z1	1	332161040R1
PCB U005	C8062	C-CERA C	CK725F1E-104Z1	1	332161040R1
PCB U005	C8063	C-CERA C	CK725F1E-104Z1	1	332161040R1
PCB U005	C8064	C-CERA C	CK725F1E-104Z1	1	332161040R1
PCB U005	C8065	C-CERA C	CK725F1E-104Z1	1	332161040R1
PCB U005	C8066	C-CERA C	CK725F1E-104Z1	1	332161040R1
PCB U005	C8077	C-CERA C	CK725F1E-104Z1	1	332161040R1
PCB U005	C8078	C-CERA C	CK725F1E-104Z1	1	332161040R1
PCB U005	C8079	C-CERA C	CK725F1E-104Z1	1	332161040R1
PCB U005	C8080	C-CERA C	CK725F1E-104Z1	1	332161040R1
PCB U005	C8142	C-CARBON R	RN72K1J-000JE	1	435030004R1
PCB U005	C8161	C-CERA C	CK725F1A-105Z1	1	332181050R1
PCB U005	C8162	CHIP ELECT C	CEWX4V-100M	1	3981G1017R2
PCB U005	C8163	C-CERA C	CK725B1H-102K1	1	332101025R1
PCB U005	C8164	C-CERA C	CK725B0J-106K	1	332091065R2
PCB U005	C8165	C-CERA C	CK725F1E-104Z1	1	332161040R1
PCB U005	C8166	C-CERA C	CK725B0J-106K	1	332091065R2
PCB U005	C8167	C-CERA C	CK725F1E-104Z1	1	332161040R1
PCB U005	C8168	C-CERA C	CK725B0J-106K	1	332091065R2
PCB U005	C8169	C-CERA C	CK725F1E-104Z1	1	332161040R1
PCB U005	C8170	C-CERA C	CK725F1E-104Z1	1	332161040R1
PCB U005	C8171	C-CERA C	CK725F1E-104Z1	1	332161040R1
PCB U005	C8172	C-CERA C	CK725F1E-104Z1	1	332161040R1
PCB U005	C8173	C-CERA C	CK725F1E-104Z1	1	332161040R1
PCB U005	C8174	C-CERA C	CK725F1E-104Z1	1	332161040R1
PCB U005	C8175	C-CERA C	CK725F1E-104Z1	1	332161040R1
PCB U005	C8176	C-CERA C	CK725F1E-104Z1	1	332161040R1
PCB U005	C8177	C-CERA C	CK725F1E-104Z1	1	332161040R1
PCB U005	C8178	C-CERA C	CK725F1E-104Z1	1	332161040R1
PCB U005	C8179	C-CERA C	CK725F1E-104Z1	1	332161040R1
PCB U005	C8180	C-CERA C	CK725F1E-104Z1	1	332161040R1
PCB U005	C8181	C-CERA C	CK725F1E-104Z1	1	332161040R1
PCB U005	C8200	CHIP TANTAL	TCSCSOJ226MAAR	1	396522207R2



PCB U005	C8200 or	CHIP TANTAL	F93-6.3V-22M	(1)	395522207R2
PCB U005	C8201	CHIP TANTAL	TCSCS0J226MAAR	1	396522207R2
PCB U005	C8201 or	CHIP TANTAL	F93-6.3V-22M	(1)	395522207R2
PCB U005	C8202	C-CERA C	CK725F1E-104Z1	1	332161040R1
PCB U005	C8203	C-CERA C	CK725F1E-104Z1	1	332161040R1
PCB U005	C8204	C-CERA C	CK725F1E-104Z1	1	332161040R1
PCB U005	C8205	C-CERA C	CK725F1E-104Z1	1	332161040R1
PCB U005	C8206	C-CERA C	CK725F1E-104Z1	1	332161040R1
PCB U005	C8207	C-CERA C	CK725F1E-104Z1	1	332161040R1
PCB U005	C8208	C-CERA C	CK725F1E-104Z1	1	332161040R1
PCB U005	C8209	C-CERA C	CK725F1E-104Z1	1	332161040R1
PCB U005	C8210	C-CERA C	CK725F1E-104Z1	1	332161040R1
PCB U005	C8211	C-CERA C	CK725F1E-104Z1	1	332161040R1
PCB U005	C8212	C-CERA C	CK725F1E-104Z1	1	332161040R1
PCB U005	C8213	C-CERA C	CK725F1E-104Z1	1	332161040R1
PCB U005	C8214	C-CERA C	CK725F1E-104Z1	1	332161040R1
PCB U005	C8215	C-CERA C	CK725F1E-104Z1	1	332161040R1
PCB U005	C8216	C-CERA C	CK725F1E-104Z1	1	332161040R1
PCB U005	C8217	C-CERA C	CK725F1E-104Z1	1	332161040R1
PCB U005	C8218	C-CERA C	CK725F1E-104Z1	1	332161040R1
PCB U005	C8219	CHIP TANTAL	TCSCS0J226MAAR	1	396522207R2
PCB U005	C8219 or	CHIP TANTAL	F93-6.3V-22M	(1)	395522207R2
PCB U005	C8220	CHIP TANTAL	TCSCS0J226MAAR	1	396522207R2
PCB U005	C8220 or	CHIP TANTAL	F93-6.3V-22M	(1)	395522207R2
PCB U005	C8221	C-CERA C	CK725B1H-103K1	1	332101035R1
PCB U005	C8222	C-CERA C	CK725B1H-103K1	1	332101035R1
PCB U005	C8223	C-CERA C	CK725F1E-104Z1	1	332161040R1
PCB U005	C8224	C-CERA C	CK725B1H-103K1	1	332101035R1
PCB U005	C8225	C-CERA C	CK725F1E-104Z1	1	332161040R1
PCB U005	C8226	C-CERA C	CK725F1E-104Z1	1	332161040R1
PCB U005	C8227	C-CERA C	CK725B1H-103K1	1	332101035R1
PCB U005	C8228	C-CERA C	CK725F1E-104Z1	1	332161040R1
PCB U005	C8229	C-CERA C	CK725F1E-104Z1	1	332161040R1
PCB U005	C8230	C-CERA C	CK725F1E-104Z1	1	332161040R1
PCB U005	C8231	C-CERA C	CK725B1H-103K1	1	332101035R1
PCB U005	C8232	C-CERA C	CK725F1E-104Z1	1	332161040R1
PCB U005	C8233	C-CERA C	CK725F1E-104Z1	1	332161040R1
PCB U005	C8234	C-CERA C	CK725F1E-104Z1	1	332161040R1
PCB U005	C8235	C-CERA C	CK725B1H-103K1	1	332101035R1
PCB U005	C8236	CHIP TANTAL	TCSCS0J226MAAR	1	396522207R2
PCB U005	C8236 or	CHIP TANTAL	F93-6.3V-22M	(1)	395522207R2

PCB U005	C8237	CHIP TANTAL	TCSCS0J226MAAR	1	396522207R2
PCB U005	C8237 or	CHIP TANTAL	F93-6.3V-22M	(1)	395522207R2
PCB U005	C8238	C-CERA C	CK725F1E-104Z1	1	332161040R1
PCB U005	C8239	C-CERA C	CK725F1E-104Z1	1	332161040R1
PCB U005	C8240	C-CERA C	CK725F1E-104Z1	1	332161040R1
PCB U005	C8241	C-CERA C	CK725F1E-104Z1	1	332161040R1
PCB U005	C8242	C-CERA C	CK725F1E-104Z1	1	332161040R1
PCB U005	C8243	C-CERA C	CK725F1E-104Z1	1	332161040R1
PCB U005	C8244	C-CERA C	CK725F1E-104Z1	1	332161040R1
PCB U005	C8245	C-CERA C	CK725F1E-104Z1	1	332161040R1
PCB U005	C8246	C-CERA C	CK725F1E-104Z1	1	332161040R1
PCB U005	C8247	C-CERA C	CK725F1E-104Z1	1	332161040R1
PCB U005	C8248	C-CERA C	CK725F1E-104Z1	1	332161040R1
PCB U005	C8249	C-CERA C	CK725F1E-104Z1	1	332161040R1
PCB U005	C8250	C-CERA C	CK725F1E-104Z1	1	332161040R1
PCB U005	C8251	CHIP TANTAL	TCSCS0J226MAAR	1	396522207R2
PCB U005	C8251 or	CHIP TANTAL	F93-6.3V-22M	(1)	395522207R2
PCB U005	C8252	C-CERA C	CK725F1E-104Z1	1	332161040R1
PCB U005	C8253	C-CERA C	CK725F1E-104Z1	1	332161040R1
PCB U005	C8254	C-CERA C	CK725F1E-104Z1	1	332161040R1
PCB U005	C8255	CHIP TANTAL	TCSCS0J226MAAR	1	396522207R2
PCB U005	C8255 or	CHIP TANTAL	F93-6.3V-22M	(1)	395522207R2
PCB U005	C8256	C-CERA C	CK725F1E-104Z1	1	332161040R1
PCB U005	C8257	C-CERA C	CK725F1E-104Z1	1	332161040R1
PCB U005	C8258	CHIP TANTAL	TCSCS0J226MAAR	1	396522207R2
PCB U005	C8258 or	CHIP TANTAL	F93-6.3V-22M	(1)	395522207R2
PCB U005	C8259	C-CERA C	CK725F1E-104Z1	1	332161040R1
PCB U005	C8260	CHIP TANTAL	TCSCS0J226MAAR	1	396522207R2
PCB U005	C8260 or	CHIP TANTAL	F93-6.3V-22M	(1)	395522207R2
PCB U005	C8261	C-CERA C	CK725F1E-104Z1	1	332161040R1
PCB U005	C8262	C-CERA C	CK725F1E-104Z1	1	332161040R1
PCB U005	C8263	C-CERA C	CK725F1E-104Z1	1	332161040R1
PCB U005	C8264	CHIP TANTAL	TCSCS0J226MAAR	1	396522207R2
PCB U005	C8264 or	CHIP TANTAL	F93-6.3V-22M	(1)	395522207R2
PCB U005	C8265	C-CERA C	CK725F1E-104Z1	1	332161040R1
PCB U005	C8266	C-CERA C	CK725F1E-104Z1	1	332161040R1
PCB U005	C8267	C-CERA C	CK725F1E-104Z1	1	332161040R1
PCB U005	C8268	CHIP TANTAL	TCSCS0J226MAAR	1	396522207R2
PCB U005	C8268 or	CHIP TANTAL	F93-6.3V-22M	(1)	395522207R2
PCB U005	C8269	C-CERA C	CK725F1E-104Z1	1	332161040R1
PCB U005	C8270	C-CERA C	CK725F1E-104Z1	1	332161040R1

PCB U005	C8271	C-CERA C	CK725F1E-104Z1	1	332161040R1
PCB U005	C8272	C-CERA C	CK725F1E-104Z1	1	332161040R1
PCB U005	C8273	CHIP TANTAL	TCSCS0J226MAAR	1	396522207R2
PCB U005	C8273 or	CHIP TANTAL	F93-6.3V-22M	(1)	395522207R2
PCB U005	C8274	C-CERA C	CK725F1E-104Z1	1	332161040R1
PCB U005	C8275	C-CERA C	CK725F1E-104Z1	1	332161040R1
PCB U005	C8276	C-CERA C	CK725B1H-103K1	1	332101035R1
PCB U005	C8282	C-CERA C	CK725F1E-104Z1	1	332161040R1
PCB U005	C8284	C-CERA C	CK725F1E-104Z1	1	332161040R1
PCB U005	C8288	C-CERA C	CC725CH1H-330J1	1	342103304R1
PCB U005	C8289	C-CERA C	CC725CH1H-330J1	1	342103304R1
PCB U005	C8290	C-CERA C	CK725B1H-102K1	1	332101025R1
PCB U005	C8291	C-CERA C	CK725F1E-104Z1	1	332161040R1
PCB U005	C8321	C-CARBON R	RN72K1J-000JE	1	435030004R1
PCB U005	C8322	C-CARBON R	RN72K1J-000JE	1	435030004R1
PCB U005	C8326	C-CERA C	CK725F1E-104Z1	1	332161040R1
PCB U005	C8327	C-CERA C	CK725F1A-105Z1	1	332181050R1
PCB U005	C8328	CHIP ELECT C	CEWX16V-22M	1	398142207R2
PCB U005	C8329	C-CERA C	CK725F1A-105Z1	1	332181050R1
PCB U005	C8330	C-CERA C	CK725F1A-105Z1	1	332181050R1
PCB U005	C8332	C-CERA C	CK725F1E-104Z1	1	332161040R1
PCB U005	C8341	C-CARBON R	RN72K1J-000JE	1	435030004R1
PCB U005	C8342	C-CARBON R	RN72K1J-000JE	1	435030004R1
PCB U005	C8348	C-CARBON R	RN72K1J-000JE	1	435030004R1
PCB U005	C8349	C-CARBON R	RN72K1J-000JE	1	435030004R1
PCB U005	C8356	C-CERA C	CK725F1E-104Z1	1	332161040R1
PCB U005	C8357	C-CERA C	CK725F1A-105Z1	1	332181050R1
PCB U005	C8358	CHIP ELECT C	CEWX16V-22M	1	398142207R2
PCB U005	C8359	C-CERA C	CK725F1A-105Z1	1	332181050R1
PCB U005	C8362	C-CERA C	CK725F1E-104Z1	1	332161040R1
PCB U005	C8364	C-CERA C	CK725B0J-106K	1	332091065R2
PCB U005	C8365	C-CERA C	CK725F1E-104Z1	1	332161040R1
PCB U005	C8366	C-CERA C	CK725B0J-106K	1	332091065R2
PCB U005	C8367	C-CERA C	CK725F1E-104Z1	1	332161040R1
PCB U005	C8368	C-CERA C	CK725B0J-106K	1	332091065R2
PCB U005	C8369	C-CERA C	CK725F1E-104Z1	1	332161040R1
PCB U005	C8370	C-CERA C	CK725F1E-104Z1	1	332161040R1
PCB U005	C8371	C-CERA C	CK725F1E-104Z1	1	332161040R1
PCB U005	C8372	C-CERA C	CK725F1E-104Z1	1	332161040R1
PCB U005	C8373	C-CERA C	CK725F1E-104Z1	1	332161040R1
PCB U005	C8374	C-CERA C	CK725F1E-104Z1	1	332161040R1

PCB U005	C8375	C-CERA C	CK725F1E-104Z1	1	332161040R1
PCB U005	C8376	C-CERA C	CK725F1E-104Z1	1	332161040R1
PCB U005	C8377	C-CERA C	CK725F1E-104Z1	1	332161040R1
PCB U005	C8378	C-CERA C	CK725F1E-104Z1	1	332161040R1
PCB U005	C8379	C-CERA C	CK725F1E-104Z1	1	332161040R1
PCB U005	C8380	C-CERA C	CK725F1E-104Z1	1	332161040R1
PCB U005	C8381	C-CERA C	CK725F1E-104Z1	1	332161040R1
PCB U005	C8390	C-CERA C	CK725F1A-105Z1	1	332181050R1
PCB U005	C8398	C-CARBON R	RN72K1J-000JE	1	435030004R1
PCB U005	C8399	C-CARBON R	RN72K1J-000JE	1	435030004R1
PCB U005	C8401	CHIP ELECT C	CEWX4V-22M	1	3981G2207R2
PCB U005	C8402	CHIP ELECT C	CEWX4V-22M	1	3981G2207R2
PCB U005	C8403	C-CERA C	CK725F1A-105Z1	1	332181050R1
PCB U005	C8404	C-CERA C	CK725B1H-102K1	1	332101025R1
PCB U005	C8405	C-CERA C	CK725F1A-105Z1	1	332181050R1
PCB U005	C8406	C-CERA C	CK725B1H-102K1	1	332101025R1
PCB U005	C8408	CHIP ELECT C	CEWX4V-22M	1	3981G2207R2
PCB U005	C8409	CHIP ELECT C	CEWX4V-22M	1	3981G2207R2
PCB U005	C8410	C-CERA C	CK725F1A-105Z1	1	332181050R1
PCB U005	C8411	C-CERA C	CK725B1H-102K1	1	332101025R1
PCB U005	C8412	C-CERA C	CK725F1A-105Z1	1	332181050R1
PCB U005	C8413	C-CERA C	CK725B1H-102K1	1	332101025R1
PCB U005	C8414	C-CERA C	CK725F1A-105Z1	1	332181050R1
PCB U005	C8415	C-CERA C	CK725B1H-102K1	1	332101025R1
PCB U005	C8416	C-CERA C	CK725B1H-102K1	1	332101025R1
PCB U005	C8417	C-CERA C	CK725F1A-105Z1	1	332181050R1
PCB U005	C8418	CHIP ELECT C	CEWX4V-22M	1	3981G2207R2
PCB U005	C8419	C-CERA C	CK725B1H-102K1	1	332101025R1
PCB U005	C8420	C-CERA C	CK725F1A-105Z1	1	332181050R1
PCB U005	C8421	C-CERA C	CK725B1H-102K1	1	332101025R1
PCB U005	C8422	C-CERA C	CK725F1A-105Z1	1	332181050R1
PCB U005	C8423	C-CERA C	CK725B1H-102K1	1	332101025R1
PCB U005	C8424	C-CERA C	CK725F1A-105Z1	1	332181050R1
PCB U005	C8425	C-CERA C	CK725B1H-102K1	1	332101025R1
PCB U005	C8426	C-CERA C	CK725F1A-105Z1	1	332181050R1
PCB U005	C8427	C-CERA C	CK725B1H-102K1	1	332101025R1
PCB U005	C8428	C-CERA C	CK725F1A-105Z1	1	332181050R1
PCB U005	C8429	C-CERA C	CK725B1H-102K1	1	332101025R1
PCB U005	C8430	C-CERA C	CK725F1A-105Z1	1	332181050R1
PCB U005	C8431	C-CERA C	CK725B1H-102K1	1	332101025R1
PCB U005	C8432	C-CERA C	CK725F1A-105Z1	1	332181050R1

PCB U005	C8433	C-CERA C	CK725B1H-102K1	1	332101025R1
PCB U005	C8434	C-CERA C	CK725F1A-105Z1	1	332181050R1
PCB U005	C8435	C-CERA C	CK725F1A-105Z1	1	332181050R1
PCB U005	C8436	C-CERA C	CK725F1A-105Z1	1	332181050R1
PCB U005	C8437	CHIP ELECT C	CEWX4V-22M	1	3981G2207R2
PCB U005	C8438	C-CERA C	CK725B1H-102K1	1	332101025R1
PCB U005	C8439	C-CERA C	CK725F1A-105Z1	1	332181050R1
PCB U005	C8440	C-CERA C	CK725B0J-106K	1	332091065R2
PCB U005	C8441	CHIP ELECT C	CEWX4V-220M	1	3981G2217R2
PCB U005	C8451	CHIP ELECT C	CEWX4V-22M	1	3981G2207R2
PCB U005	C8452	CHIP ELECT C	CEWX4V-22M	1	3981G2207R2
PCB U005	C8453	C-CERA C	CK725F1A-105Z1	1	332181050R1
PCB U005	C8454	C-CERA C	CK725B1H-102K1	1	332101025R1
PCB U005	C8455	C-CERA C	CK725F1A-105Z1	1	332181050R1
PCB U005	C8456	C-CERA C	CK725B1H-102K1	1	332101025R1
PCB U005	C8457	C-CERA C	CC725CH1H-020C1	1	342100201R1
PCB U005	C8458	CHIP ELECT C	CEWX4V-22M	1	3981G2207R2
PCB U005	C8459	CHIP ELECT C	CEWX4V-22M	1	3981G2207R2
PCB U005	C8460	C-CERA C	CK725F1A-105Z1	1	332181050R1
PCB U005	C8461	C-CERA C	CK725B1H-102K1	1	332101025R1
PCB U005	C8462	C-CERA C	CK725F1A-105Z1	1	332181050R1
PCB U005	C8463	C-CERA C	CK725B1H-102K1	1	332101025R1
PCB U005	C8464	C-CERA C	CK725F1A-105Z1	1	332181050R1
PCB U005	C8465	C-CERA C	CK725B1H-102K1	1	332101025R1
PCB U005	C8466	C-CERA C	CK725B1H-102K1	1	332101025R1
PCB U005	C8467	C-CERA C	CK725F1A-105Z1	1	332181050R1
PCB U005	C8468	CHIP ELECT C	CEWX4V-22M	1	3981G2207R2
PCB U005	C8469	C-CERA C	CK725B1H-102K1	1	332101025R1
PCB U005	C8470	C-CERA C	CK725F1A-105Z1	1	332181050R1
PCB U005	C8471	C-CERA C	CK725B1H-102K1	1	332101025R1
PCB U005	C8472	C-CERA C	CK725F1A-105Z1	1	332181050R1
PCB U005	C8473	C-CERA C	CK725B1H-102K1	1	332101025R1
PCB U005	C8474	C-CERA C	CK725F1A-105Z1	1	332181050R1
PCB U005	C8475	C-CERA C	CK725B1H-102K1	1	332101025R1
PCB U005	C8476	C-CERA C	CK725F1A-105Z1	1	332181050R1
PCB U005	C8477	C-CERA C	CK725B1H-102K1	1	332101025R1
PCB U005	C8478	C-CERA C	CK725F1A-105Z1	1	332181050R1
PCB U005	C8479	C-CERA C	CK725B1H-102K1	1	332101025R1
PCB U005	C8480	C-CERA C	CK725F1A-105Z1	1	332181050R1
PCB U005	C8481	C-CERA C	CK725B1H-102K1	1	332101025R1
PCB U005	C8482	C-CERA C	CK725F1A-105Z1	1	332181050R1

PCB U005	C8483	C-CERA C	CK725B1H-102K1	1	332101025R1
PCB U005	C8484	C-CERA C	CK725F1A-105Z1	1	332181050R1
PCB U005	C8485	C-CERA C	CK725F1A-105Z1	1	332181050R1
PCB U005	C8486	C-CERA C	CK725F1A-105Z1	1	332181050R1
PCB U005	C8487	CHIP ELECT C	CEWX4V-22M	1	3981G2207R2
PCB U005	C8488	C-CERA C	CK725B1H-102K1	1	332101025R1
PCB U005	C8489	C-CERA C	CK725F1A-105Z1	1	332181050R1
PCB U005	C8490	C-CERA C	CK725B0J-106K	1	332091065R2
PCB U005	C8491	CHIP ELECT C	CEWX4V-220M	1	3981G2217R2
PCB U005	C8501	C-CERA C	CK725B1H-102K1	1	332101025R1
PCB U005	C8502	C-CERA C	CK725B0J-106K	1	332091065R2
PCB U005	C8503	C-CERA C	CK725F1A-105Z1	1	332181050R1
PCB U005	C8504	C-CERA C	CK725B1H-102K1	1	332101025R1
PCB U005	C8505	C-CERA C	CK725F1A-105Z1	1	332181050R1
PCB U005	C8506	C-CERA C	CK725B0J-106K	1	332091065R2
PCB U005	C8507	C-CERA C	CK725B1H-102K1	1	332101025R1
PCB U005	C8508	C-CERA C	CK725F1A-105Z1	1	332181050R1
PCB U005	C8509	C-CERA C	CK725B1H-102K1	1	332101025R1
PCB U005	C8510	C-CERA C	CK725F1A-105Z1	1	332181050R1
PCB U005	C8511	C-CERA C	CK725B1H-102K1	1	332101025R1
PCB U005	C8512	C-CERA C	CK725F1A-105Z1	1	332181050R1
PCB U005	C8513	C-CERA C	CK725B1H-102K1	1	332101025R1
PCB U005	C8514	C-CERA C	CK725F1A-105Z1	1	332181050R1
PCB U005	C8515	C-CERA C	CK725B1H-102K1	1	332101025R1
PCB U005	C8516	C-CERA C	CK725F1A-105Z1	1	332181050R1
PCB U005	C8517	C-CERA C	CK725B1H-102K1	1	332101025R1
PCB U005	C8518	C-CERA C	CK725F1A-105Z1	1	332181050R1
PCB U005	C8519	C-CERA C	CK725F1A-105Z1	1	332181050R1
PCB U005	C8521	C-CERA C	CK725F1E-104Z1	1	332161040R1
PCB U005	C8522	C-CERA C	CK725B0J-106K	1	332091065R2
PCB U005	C8525	C-CERA C	CK725B0J-106K	1	332091065R2
PCB U005	C8527	C-CERA C	CK725B1H-102K1	1	332101025R1
PCB U005	C8529	C-CERA C	CK725B0J-106K	1	332091065R2
PCB U005	C8530	C-CERA C	CK725F1A-105Z1	1	332181050R1
PCB U005	C8531	C-CERA C	CK725B1H-102K1	1	332101025R1
PCB U005	C8532	C-CERA C	CK725F1A-105Z1	1	332181050R1
PCB U005	C8533	C-CERA C	CK725B1H-102K1	1	332101025R1
PCB U005	C8534	C-CERA C	CK725F1A-105Z1	1	332181050R1
PCB U005	C8535	C-CERA C	CK725B1H-102K1	1	332101025R1
PCB U005	C8536	C-CERA C	CK725F1A-105Z1	1	332181050R1
PCB U005	C8537	C-CERA C	CK725B1H-102K1	1	332101025R1

PCB U005	C8538	C-CERA C	CK725F1A-105Z1	1	332181050R1
PCB U005	C8539	C-CERA C	CK725B1H-102K1	1	332101025R1
PCB U005	C8540	C-CERA C	CK725F1A-105Z1	1	332181050R1
PCB U005	C8548	C-CERA C	CK725F1A-105Z1	1	332181050R1
PCB U005	C8549	C-CERA C	CK725B1H-102K1	1	332101025R1
PCB U005	C8550	C-CERA C	CK725F1A-105Z1	1	332181050R1
PCB U005	C8551	C-CERA C	CK725B1H-102K1	1	332101025R1
PCB U005	C8552	C-CERA C	CK725F1A-105Z1	1	332181050R1
PCB U005	C8553	C-CERA C	CK725B1H-102K1	1	332101025R1
PCB U005	C8554	C-CERA C	CK725F1A-105Z1	1	332181050R1
PCB U005	C8555	C-CERA C	CK725B1H-102K1	1	332101025R1
PCB U005	C8556	C-CERA C	CK725F1A-105Z1	1	332181050R1
PCB U005	C8557	C-CERA C	CK725B1H-102K1	1	332101025R1
PCB U005	C8558	C-CERA C	CK725F1A-105Z1	1	332181050R1
PCB U005	C8559	C-CERA C	CK725B1H-102K1	1	332101025R1
PCB U005	C8560	C-CERA C	CK725B0J-106K	1	332091065R2
PCB U005	C8563	C-CERA C	CK725F1A-105Z1	1	332181050R1
PCB U005	C8564	C-CERA C	CK725B0J-106K	1	332091065R2
PCB U005	C8565	C-CERA C	CK725B0J-106K	1	332091065R2
PCB U005	C8566	C-CERA C	CK725B1H-102K1	1	332101025R1
PCB U005	C8567	C-CERA C	CK725F1A-105Z1	1	332181050R1
PCB U005	C8573	C-CERA C	CK725F1A-105Z1	1	332181050R1
PCB U005	C8574	C-CERA C	CC725CH1H-070D1	1	342100702R1
PCB U005	C8575	C-CERA C	CC725CH1H-070D1	1	342100702R1
PCB U005	C8584	C-CERA C	CK725B0J-106K	1	332091065R2
PCB U005	C8585	C-CERA C	CK725B0J-106K	1	332091065R2
PCB U005	C8605	C-CARBON R	RN72K1J-000JE	1	435030004R1
PCB U005	C8608	C-CERA C	CK725F1A-105Z1	1	332181050R1
PCB U005	C8609	C-CERA C	CK725B0J-106K	1	332091065R2
PCB U005	C8611	C-CARBON R	RN72K1J-000JE	1	435030004R1
PCB U005	C8612	C-CARBON R	RN72K1J-000JE	1	435030004R1
PCB U005	C8621	C-CARBON R	RN72K1J-000JE	1	435030004R1
PCB U005	C8622	C-CARBON R	RN72K1J-000JE	1	435030004R1
PCB U005	C8631	C-CARBON R	RN72K1J-000JE	1	435030004R1
PCB U005	C8632	C-CARBON R	RN72K1J-000JE	1	435030004R1
PCB U005	C8675	CHIP ELECT C	CEWX4V-100M	1	3981G1017R2
PCB U005	C8676	C-CERA C	CK725F1A-105Z1	1	332181050R1
PCB U005	C8701	C-CERA C	CK725F1A-105Z1	1	332181050R1
PCB U005	C8702	C-CERA C	CK725F1A-105Z1	1	332181050R1
PCB U005	C8703	C-CERA C	CK725F1A-105Z1	1	332181050R1
PCB U005	C8704	CHIP ELECT C	CEWX50V-4.7M	1	398180477R2

PCB U005	C8705	C-CERA C	CK725F1A-105Z1	1	332181050R1
PCB U005	C8706	C-CERA C	CK725F1A-105Z1	1	332181050R1
PCB U005	C8707	C-CERA C	CK725F1A-105Z1	1	332181050R1
PCB U005	C8708	C-CERA C	CK725F1A-105Z1	1	332181050R1
PCB U005	C8709	CHIP ELECT C	CEWX4V-220M	1	3981G2217R2
PCB U005	C8710	C-CERA C	CK725F1A-105Z1	1	332181050R1
PCB U005	C8801	C-CERA C	CK725F1A-105Z1	1	332181050R1
PCB U005	C8802	CHIP ELECT C	CEWX4V-220M	1	3981G2217R2
PCB U005	C8803	CHIP ELECT C	CEWX4V-220M	1	3981G2217R2
PCB U005	C8804	CHIP ELECT C	CEWX4V-220M	1	3981G2217R2
PCB U005	C8805	CHIP ELECT C	CEWX4V-220M	1	3981G2217R2
PCB U005	C8810	C-CERA C	CK725F1A-105Z1	1	332181050R1
PCB U005	C8811	C-CERA C	CK725F1A-105Z1	1	332181050R1
PCB U005	C8812	C-CERA C	CK725B1A-154K1	1	332131545R1
PCB U005	C8813	C-CERA C	CK725B1H-153K1	1	332101535R1
PCB U005	C8814	C-CERA C	CK725F1A-105Z1	1	332181050R1
PCB U005	C8815	C-CERA C	CK725B1A-154K1	1	332131545R1
PCB U005	C8816	C-CERA C	CK725B1H-153K1	1	332101535R1
PCB U005	C8817	C-CERA C	CK725B1H-222K1	1	332102225R1
PCB U005	C8818	C-CERA C	CK725F1A-105Z1	1	332181050R1
PCB U005	C8819	C-CERA C	CK725B1H-222K1	1	332102225R1
PCB U005	C8820	C-CERA C	CK725F1A-105Z1	1	332181050R1
PCB U005	C8821	C-CERA C	CK725F1A-105Z1	1	332181050R1
PCB U005	C8822	C-CERA C	CK725F1A-105Z1	1	332181050R1
PCB U005	C8823	C-CERA C	CK725F1A-105Z1	1	332181050R1
PCB U005	C8825	C-CERA C	CK725B0J-225K	1	332092255R1
PCB U005	C8826	CHIP ELECT C	CEWX4V-100M	1	3981G1017R2
PCB U005	C8838	C-CERA C	CC725CH1H-470J1	1	342104704R1
PCB U005	C8839	C-CERA C	CC725CH1H-470J1	1	342104704R1
PCB U005	C8840	C-CERA C	CC725CH1H-470J1	1	342104704R1
PCB U005	C8855	C-CERA C	CK725F1E-104Z1	1	332161040R1
PCB U005	C8856	C-CERA C	CK725F1E-104Z1	1	332161040R1
PCB U005	C8857	C-CERA C	CK725F1E-104Z1	1	332161040R1
PCB U005	C8858	C-CERA C	CK725F1E-104Z1	1	332161040R1
PCB U005	C8859	C-CERA C	CK725F1E-104Z1	1	332161040R1
PCB U005	C8860	C-CERA C	CK725F1E-104Z1	1	332161040R1
PCB U005	C8861	C-CERA C	CK725F1E-104Z1	1	332161040R1
PCB U005	C8862	C-CERA C	CK725F1E-104Z1	1	332161040R1
PCB U005	C8863	C-CERA C	CK725F1E-104Z1	1	332161040R1
PCB U005	C8864	C-CERA C	CK725F1E-104Z1	1	332161040R1
PCB U005	C8865	C-CERA C	CK725F1E-104Z1	1	332161040R1



PCB U005	C8866	C-CERA C	CK725F1E-104Z1	1	332161040R1
PCB U005	C8867	C-CERA C	CK725F1E-104Z1	1	332161040R1
PCB U005	C8868	C-CERA C	CK725F1E-104Z1	1	332161040R1
PCB U005	C8869	C-CERA C	CK725F1E-104Z1	1	332161040R1
PCB U005	C8870	C-CERA C	CK725F1E-104Z1	1	332161040R1
PCB U005	C8951	C-CERA C	CK725B1C-104K1	1	332121045R1
PCB U005	C8952	C-CERA C	CK725F1A-105Z1	1	332181050R1
PCB U005	C8953	CD C	UCD1E221MNL1GS	1	396652217R2
PCB U005	C8954	C-CERA C	CK725B1H-103K1	1	332101035R1
PCB U005	C8955	C-CERA C	CK725B1H-332K1	1	332103325R1
PCB U005	C8956	C-CERA C	CK725F1A-105Z1	1	332181050R1
PCB U005	C8957	CHIP ELECT C	CEWT10V-470M	1	395734717R2
PCB U005	C8958	C-CERA C	CK725F1A-105Z1	1	332181050R1
PCB U005	C8961	C-CERA C	CK725B1A-224K1	1	332132245R1
PCB U005	C8962	C-CERA C	CK725F1A-105Z1	1	332181050R1
PCB U005	C8963	CD C	UCD1E221MNL1GS	1	396652217R2
PCB U005	C8964	C-CERA C	CK725B1H-332K1	1	332103325R1
PCB U005	C8965	C-CERA C	CK725B1H-332K1	1	332103325R1
PCB U005	C8966	C-CERA C	CK725F1A-105Z1	1	332181050R1
PCB U005	C8967	CHIP ELECT C	CEWT10V-470M	1	395734717R2
PCB U005	C8968	C-CERA C	CK725F1A-105Z1	1	332181050R1
PCB U005	C8971	C-CERA C	CK725B1C-104K1	1	332121045R1
PCB U005	C8972	C-CERA C	CK725F1A-105Z1	1	332181050R1
PCB U005	C8973	CD C	UCD1E221MNL1GS	1	396652217R2
PCB U005	C8974	C-CERA C	CK725B1H-332K1	1	332103325R1
PCB U005	C8975	C-CERA C	CK725B1H-332K1	1	332103325R1
PCB U005	C8976	C-CERA C	CK725F1A-105Z1	1	332181050R1
PCB U005	C8977	CHIP ELECT C	CEWT10V-470M	1	395734717R2
PCB U005	C8978	C-CERA C	CK725F1A-105Z1	1	332181050R1
PCB U005	C8979	C-CERA C	CK725F1A-105Z1	1	332181050R1
PCB U005	C8981	C-CERA C	CK725B1H-223K1	1	332102235R1
PCB U005	C8982	C-CERA C	CK725F1A-105Z1	1	332181050R1
PCB U005	C8983	CD C	UCD1E221MNL1GS	1	396652217R2
PCB U005	C8984	C-CERA C	CK725B1H-103K1	1	332101035R1
PCB U005	C8985	C-CERA C	CK725B1H-222K1	1	332102225R1
PCB U005	C8986	C-CERA C	CK725F1A-105Z1	1	332181050R1
PCB U005	C8987	CHIP ELECT C	CEWT10V-470M	1	395734717R2
PCB U005	C8988	C-CERA C	CK725F1A-105Z1	1	332181050R1
PCB U005	[RESISTOR]				
PCB U005	R268	C-CARBON R	RN72K1J-331JE	1	435033314R1
PCB U005	R269	C-CARBON R	RN72K1J-331JE	1	435033314R1

PCB U005	R270	C-CARBON R	RN72K1J-331JE	1	435033314R1
PCB U005	R271	C-CARBON R	RN72K1J-470JE	1	435034704R1
PCB U005	R272	C-CARBON R	RN72K1J-331JE	1	435033314R1
PCB U005	R273	C-CARBON R	RN72K1J-331JE	1	435033314R1
PCB U005	R274	C-CARBON R	RN72K1J-470JE	1	435034704R1
PCB U005	R275	C-CARBON R	RN72K1J-221JE	1	435032214R1
PCB U005	R276	C-CARBON R	RN72K1J-221JE	1	435032214R1
PCB U005	R277	C-CARBON R	RN72K1J-151JE	1	435031514R1
PCB U005	R278	C-CARBON R	RN72K1J-331JE	1	435033314R1
PCB U005	R279	C-CARBON R	RN72K1J-331JE	1	435033314R1
PCB U005	R280	C-CARBON R	RN72K1J-470JE	1	435034704R1
PCB U005	R3009	C-CARBON R	RN72K1J-330JE	1	435033304R1
PCB U005	R3010	C-R NET	RM7LJ330X04	1	43484733004R2
PCB U005	R3011	C-R NET	RM7LJ330X04	1	43484733004R2
PCB U005	R3012	C-R NET	RM7LJ330X04	1	43484733004R2
PCB U005	R3013	C-R NET	RM7LJ330X04	1	43484733004R2
PCB U005	R3014	C-R NET	RM7LJ330X04	1	43484733004R2
PCB U005	R3015	C-R NET	RM7LJ330X04	1	43484733004R2
PCB U005	R3016	C-CARBON R	RN72K1J-470JE	1	435034704R1
PCB U005	R3017	C-R NET	RM7LJ330X04	1	43484733004R2
PCB U005	R3018	C-CARBON R	RN72K1J-470JE	1	435034704R1
PCB U005	R3019	C-R NET	RM7LJ330X04	1	43484733004R2
PCB U005	R3020	C-R NET	RM7LJ330X04	1	43484733004R2
PCB U005	R3021	C-CARBON R	RN72K1J-470JE	1	435034704R1
PCB U005	R3022	C-CARBON R	RN72K1J-470JE	1	435034704R1
PCB U005	R3023	C-R NET	RM7LJ470X04	1	43484747004R2
PCB U005	R3024	C-CARBON R	RN72K1J-470JE	1	435034704R1
PCB U005	R3025	C-CARBON R	RN72K1J-102JE	1	435031024R1
PCB U005	R3026	C-CARBON R	RN72K1J-470JE	1	435034704R1
PCB U005	R3028	C-CARBON R	RN72K1J-470JE	1	435034704R1
PCB U005	R3029	C-CARBON R	RN72K1J-102JE	1	435031024R1
PCB U005	R3032	C-CARBON R	RN72K1J-103JE	1	435031034R1
PCB U005	R3033	C-CARBON R	RN72K1J-470JE	1	435034704R1
PCB U005	R3034	C-CARBON R	RN72K1J-470JE	1	435034704R1
PCB U005	R3035	C-CARBON R	RN72K1J-470JE	1	435034704R1
PCB U005	R3036	C-CARBON R	RN72K1J-470JE	1	435034704R1
PCB U005	R3037	C-CARBON R	RN72K1J-470JE	1	435034704R1
PCB U005	R3038	C-CARBON R	RN72K1J-470JE	1	435034704R1
PCB U005	R3039	C-CARBON R	RN72K1J-470JE	1	435034704R1
PCB U005	R3040	C-CARBON R	RN72K1J-103JE	1	435031034R1
PCB U005	R3041	C-R NET	RM7LJ330X04	1	43484733004R2

PCB U005	R3042	C-R NET	RM7LJ330X04	1	43484733004R2
PCB U005	R3043	C-CARBON R	RN72K1J-000JE	1	435030004R1
PCB U005	R3044	C-R NET	RM7LJ330X04	1	43484733004R2
PCB U005	R3045	C-R NET	RM7LJ330X04	1	43484733004R2
PCB U005	R3047	C-CARBON R	RN72K1J-560JE	1	435035604R1
PCB U005	R3048	C-CARBON R	RN72K1J-000JE	1	435030004R1
PCB U005	R3049	C-CARBON R	RN72K1J-560JE	1	435035604R1
PCB U005	R3050	C-CARBON R	RN72K1J-560JE	1	435035604R1
PCB U005	R3051	C-CARBON R	RN72K1J-560JE	1	435035604R1
PCB U005	R3052	C-CARBON R	RN72K1J-103JE	1	435031034R1
PCB U005	R3053	C-CARBON R	RN72K1J-103JE	1	435031034R1
PCB U005	R3054	C-CARBON R	RN72K1J-103JE	1	435031034R1
PCB U005	R3055	C-CARBON R	RN72K1J-472JE	1	435034724R1
PCB U005	R3056	C-CARBON R	RN72K1J-472JE	1	435034724R1
PCB U005	R3060	C-CARBON R	RN72K1J-680JE	1	435036804R1
PCB U005	R3061	C-CARBON R	RN72K1J-470JE	1	435034704R1
PCB U005	R3062	C-CARBON R	RN72K1J-680JE	1	435036804R1
PCB U005	R3063	C-CARBON R	RN72K1J-680JE	1	435036804R1
PCB U005	R3064	C-CARBON R	RN72K1J-680JE	1	435036804R1
PCB U005	R3065	C-CARBON R	RN72K1J-680JE	1	435036804R1
PCB U005	R3066	C-CARBON R	RN72K1J-102JE	1	435031024R1
PCB U005	R3101	C-CARBON R	RN72K1J-103JE	1	435031034R1
PCB U005	R3102	C-CARBON R	RN72K1J-153JE	1	435031534R1
PCB U005	R3108	C-CARBON R	RN72K1J-103JE	1	435031034R1
PCB U005	R3110	C-CARBON R	RN72K1J-103JE	1	435031034R1
PCB U005	R3111	C-CARBON R	RN72K1J-103JE	1	435031034R1
PCB U005	R3113	C-CARBON R	RN72K1J-103JE	1	435031034R1
PCB U005	R3115	C-CARBON R	RN72K1J-103JE	1	435031034R1
PCB U005	R3117	C-CARBON R	RN72K1J-103JE	1	435031034R1
PCB U005	R3119	C-CARBON R	RN72K1J-472JE	1	435034724R1
PCB U005	R3121	C-CARBON R	RN72K1J-153JE	1	435031534R1
PCB U005	R3122	C-CARBON R	RN72K1J-102JE	1	435031024R1
PCB U005	R3123	C-CARBON R	RN72K1J-000JE	1	435030004R1
PCB U005	R3124	C-CARBON R	RN72K1J-331JE	1	435033314R1
PCB U005	R3125	C-CARBON R	RN72K1J-470JE	1	435034704R1
PCB U005	R3126	C-CARBON R	RN72K1J-470JE	1	435034704R1
PCB U005	R3127	C-CARBON R	RN72K1J-470JE	1	435034704R1
PCB U005	R3128	C-CARBON R	RN72K1J-472JE	1	435034724R1
PCB U005	R3129	C-CARBON R	RN72K1J-470JE	1	435034704R1
PCB U005	R3130	C-CARBON R	RN72K1J-470JE	1	435034704R1
PCB U005	R3131	C-CARBON R	RN72K1J-470JE	1	435034704R1

PCB U005	R3132	C-CARBON R	RN72K1J-103JE	1	435031034R1
PCB U005	R3133	C-CARBON R	RN72K1J-470JE	1	435034704R1
PCB U005	R3134	C-CARBON R	RN72K1J-103JE	1	435031034R1
PCB U005	R3135	C-CARBON R	RN72K1J-103JE	1	435031034R1
PCB U005	R3136	C-CARBON R	RN72K1J-000JE	1	435030004R1
PCB U005	R3137	C-CARBON R	RN72K1J-000JE	1	435030004R1
PCB U005	R3139	C-CARBON R	RN72K1J-101JE	1	435031014R1
PCB U005	R3140	C-CARBON R	RN72K1J-103JE	1	435031034R1
PCB U005	R3143	C-CARBON R	RN72K1J-103JE	1	435031034R1
PCB U005	R3144	C-CARBON R	RN72K1J-101JE	1	435031014R1
PCB U005	R3145	C-CARBON R	RN72K1J-103JE	1	435031034R1
PCB U005	R3146	C-CARBON R	RN72K1J-390JE	1	435033904R1
PCB U005	R3147	C-CARBON R	RN72K1J-000JE	1	435030004R1
PCB U005	R3148	C-CARBON R	RN72K1J-390JE	1	435033904R1
PCB U005	R3149	C-CARBON R	RN72K1J-102JE	1	435031024R1
PCB U005	R3150	C-CARBON R	RN72K1J-330JE	1	435033304R1
PCB U005	R3151	C-CARBON R	RN72K1J-103JE	1	435031034R1
PCB U005	R3152	C-CARBON R	RN72K1J-103JE	1	435031034R1
PCB U005	R3154	C-CARBON R	RN72K1J-390JE	1	435033904R1
PCB U005	R3155	C-CARBON R	RN72K1J-390JE	1	435033904R1
PCB U005	R3156	C-CARBON R	RN72K1J-390JE	1	435033904R1
PCB U005	R3157	C-CARBON R	RN72K1J-000JE	1	435030004R1
PCB U005	R3158	C-CARBON R	RN72K1J-000JE	1	435030004R1
PCB U005	R3159	C-CARBON R	RN72K1J-000JE	1	435030004R1
PCB U005	R3160	C-CARBON R	RN72K1J-000JE	1	435030004R1
PCB U005	R3162	C-CARBON R	RN72K1J-390JE	1	435033904R1
PCB U005	R3163	C-CARBON R	RN72K1J-220JE	1	435032204R1
PCB U005	R3164	C-CARBON R	RN72K1J-472JE	1	435034724R1
PCB U005	R3168	C-CARBON R	RN72K1J-220JE	1	435032204R1
PCB U005	R3169	C-CARBON R	RN72K1J-220JE	1	435032204R1
PCB U005	R3170	C-CARBON R	RN72K1J-391FE	1	435033912R1
PCB U005	R3171	C-CARBON R	RN72K1J-222FE	1	435032222R1
PCB U005	R3172	C-CARBON R	RN72K1J-392FE	1	435033922R1
PCB U005	R3173	C-CARBON R	RN72K1J-390JE	1	435033904R1
PCB U005	R3174	C-CARBON R	RN72K1J-390JE	1	435033904R1
PCB U005	R3176	C-CARBON R	MCR03EZPF49R9(49.9_1%)	1	4100037R2
PCB U005	R3177	C-CARBON R	MCR03EZPF49R9(49.9_1%)	1	4100037R2
PCB U005	R3178	C-CARBON R	MCR03EZPF49R9(49.9_1%)	1	4100037R2
PCB U005	R3179	C-CARBON R	MCR03EZPF49R9(49.9_1%)	1	4100037R2
PCB U005	R3180	C-CARBON R	RN72K1J-100FE	1	435031002R1
PCB U005	R3181	C-CARBON R	RN72K1J-470JE	1	435034704R1

PCB U005	R3182	C-CARBON R	RN72K1J-472JE	1	435034724R1
PCB U005	R3183	C-CARBON R	RN72K1J-470JE	1	435034704R1
PCB U005	R3184	C-CARBON R	RN72K1J-470JE	1	435034704R1
PCB U005	R3185	C-CARBON R	RN72K1J-392FE	1	435033922R1
PCB U005	R3186	C-CARBON R	RN72K1J-472JE	1	435034724R1
PCB U005	R3187	C-CARBON R	RN72K1J-223FE	1	435032232R1
PCB U005	R3188	C-CARBON R	RN72K1J-224FE	1	435032242R1
PCB U005	R3189	C-CARBON R	RN72K1J-103FE	1	435031032R1
PCB U005	R3190	C-CARBON R	RN72K1J-393FE	1	435033932R1
PCB U005	R3191	C-CARBON R	RN72K1J-105FE	1	435031052R1
PCB U005	R3192	C-CARBON R	RN72K1J-472JE	1	435034724R1
PCB U005	R3193	C-CARBON R	RN72K1J-472JE	1	435034724R1
PCB U005	R3194	C-CARBON R	RN72K1J-472JE	1	435034724R1
PCB U005	R3195	C-CARBON R	RN72K1J-221JE	1	435032214R1
PCB U005	R3196	C-CARBON R	RN72K1J-221JE	1	435032214R1
PCB U005	R3199	C-CARBON R	RN72K1J-102JE	1	435031024R1
PCB U005	R3200	C-CARBON R	RN72K1J-103JE	1	435031034R1
PCB U005	R3201	C-CARBON R	RN72K1J-103JE	1	435031034R1
PCB U005	R3202	C-CARBON R	RN72K1J-103JE	1	435031034R1
PCB U005	R3203	C-CARBON R	RN72K1J-103JE	1	435031034R1
PCB U005	R3204	C-CARBON R	RN72K1J-103JE	1	435031034R1
PCB U005	R3205	C-CARBON R	RN72K1J-103JE	1	435031034R1
PCB U005	R3208	C-CARBON R	RN72K1J-220JE	1	435032204R1
PCB U005	R3212	C-CARBON R	RN72K1J-220JE	1	435032204R1
PCB U005	R3215	C-CARBON R	RN72K1J-221JE	1	435032214R1
PCB U005	R3218	C-CARBON R	RN72K1J-220JE	1	435032204R1
PCB U005	R3219	C-CARBON R	RN72K1J-221JE	1	435032214R1
PCB U005	R3221	C-CARBON R	RN72K1J-470JE	1	435034704R1
PCB U005	R3224	C-CARBON R	RN72K1J-220JE	1	435032204R1
PCB U005	R3225	C-CARBON R	RN72K1J-220JE	1	435032204R1
PCB U005	R3226	C-R NET	RM7LJ470X04	1	43484747004R2
PCB U005	R3227	C-CARBON R	RN72K1J-470JE	1	435034704R1
PCB U005	R3228	C-CARBON R	RN72K1J-470JE	1	435034704R1
PCB U005	R3229	C-CARBON R	RN72K1J-470JE	1	435034704R1
PCB U005	R3230	C-CARBON R	RN72K1J-221JE	1	435032214R1
PCB U005	R3231	C-CARBON R	RN72K1J-470JE	1	435034704R1
PCB U005	R3232	C-CARBON R	RN72K1J-221JE	1	435032214R1
PCB U005	R3233	C-CARBON R	RN72K1J-221JE	1	435032214R1
PCB U005	R3234	C-CARBON R	RN72K1J-470JE	1	435034704R1
PCB U005	R3236	C-CARBON R	RN72K1J-470JE	1	435034704R1
PCB U005	R3237	C-CARBON R	RN72K1J-221JE	1	435032214R1

PCB U005	R3238	C-CARBON R	RN72K1J-470JE	1	435034704R1
PCB U005	R3239	C-CARBON R	RN72K1J-221JE	1	435032214R1
PCB U005	R3240	C-CARBON R	RN72K1J-103JE	1	435031034R1
PCB U005	R3241	C-CARBON R	RN72K1J-221JE	1	435032214R1
PCB U005	R3242	C-CARBON R	RN72K1J-221JE	1	435032214R1
PCB U005	R3243	C-CARBON R	RN72K1J-220JE	1	435032204R1
PCB U005	R3244	C-CARBON R	RN72K1J-470JE	1	435034704R1
PCB U005	R3245	C-CARBON R	RN72K1J-103JE	1	435031034R1
PCB U005	R3246	C-CARBON R	RN72K1J-103JE	1	435031034R1
PCB U005	R3247	C-CARBON R	RN72K1J-331JE	1	435033314R1
PCB U005	R3248	C-CARBON R	RN72K1J-220JE	1	435032204R1
PCB U005	R3249	C-CARBON R	RN72K1J-470JE	1	435034704R1
PCB U005	R3250	C-CARBON R	RN72K1J-470JE	1	435034704R1
PCB U005	R3251	C-CARBON R	RN72K1J-470JE	1	435034704R1
PCB U005	R3252	C-CARBON R	RN72K1J-220JE	1	435032204R1
PCB U005	R3253	C-CARBON R	RN72K1J-470JE	1	435034704R1
PCB U005	R3254	C-CARBON R	RN72K1J-470JE	1	435034704R1
PCB U005	R3255	C-CARBON R	RN72K1J-103JE	1	435031034R1
PCB U005	R3256	C-CARBON R	RN72K1J-470JE	1	435034704R1
PCB U005	R3257	C-CARBON R	RN72K1J-470JE	1	435034704R1
PCB U005	R3259	C-CARBON R	RN72K1J-220JE	1	435032204R1
PCB U005	R3260	C-CARBON R	RN72K1J-390JE	1	435033904R1
PCB U005	R3261	C-CARBON R	RN72K1J-470JE	1	435034704R1
PCB U005	R3262	C-CARBON R	RN72K1J-221JE	1	435032214R1
PCB U005	R3264	C-CARBON R	RN72K1J-470JE	1	435034704R1
PCB U005	R3265	C-CARBON R	RN72K1J-390JE	1	435033904R1
PCB U005	R3267	C-CARBON R	RN72K1J-470JE	1	435034704R1
PCB U005	R3268	C-CARBON R	RN72K1J-390JE	1	435033904R1
PCB U005	R3270	C-CARBON R	RN72K1J-470JE	1	435034704R1
PCB U005	R3271	C-CARBON R	RN72K1J-390JE	1	435033904R1
PCB U005	R3272	C-CARBON R	RN72K1J-470JE	1	435034704R1
PCB U005	R3273	C-CARBON R	RN72K1J-470JE	1	435034704R1
PCB U005	R3274	C-CARBON R	RN72K1J-390JE	1	435033904R1
PCB U005	R3275	C-CARBON R	RN72K1J-220JE	1	435032204R1
PCB U005	R3276	C-CARBON R	RN72K1J-470JE	1	435034704R1
PCB U005	R3277	C-CARBON R	RN72K1J-220JE	1	435032204R1
PCB U005	R3278	C-CARBON R	RN72K1J-470JE	1	435034704R1
PCB U005	R3279	C-CARBON R	RN72K1J-470JE	1	435034704R1
PCB U005	R3280	C-CARBON R	RN72K1J-470JE	1	435034704R1
PCB U005	R3281	C-CARBON R	RN72K1J-103JE	1	435031034R1
PCB U005	R3282	C-CARBON R	RN72K1J-103JE	1	435031034R1

PCB U005	R3283	C-CARBON R	RN72K1J-103JE	1	435031034R1
PCB U005	R3284	C-CARBON R	RN72K1J-103JE	1	435031034R1
PCB U005	R3285	C-CARBON R	RN72K1J-103JE	1	435031034R1
PCB U005	R3286	C-CARBON R	RN72K1J-103JE	1	435031034R1
PCB U005	R3287	C-CARBON R	RN72K1J-220JE	1	435032204R1
PCB U005	R3288	C-CARBON R	RN72K1J-223JE	1	435032234R1
PCB U005	R3289	C-CARBON R	RN72K1J-152JE	1	435031524R1
PCB U005	R3290	C-CARBON R	RN72K1J-105JE	1	435031054R1
PCB U005	R3291	C-CARBON R	RN72K1J-105JE	1	435031054R1
PCB U005	R3292	C-CARBON R	RN72K1J-561FE	1	435035612R1
PCB U005	R3293	C-CARBON R	RN72K1J-560JE	1	435035604R1
PCB U005	R3294	C-CARBON R	RN72K1J-561FE	1	435035612R1
PCB U005	R3295	C-CARBON R	RN72K1J-560JE	1	435035604R1
PCB U005	R3296	C-CARBON R	RN72K1J-223JE	1	435032234R1
PCB U005	R3297	C-CARBON R	RN72K1J-332JE	1	435033324R1
PCB U005	R3298	C-CARBON R	RN72K1J-182JE	1	435031824R1
PCB U005	R3299	C-CARBON R	RN72K1J-220JE	1	435032204R1
PCB U005	R3300	C-CARBON R	RN72K1J-153JE	1	435031534R1
PCB U005	R3301	C-CARBON R	RN72K1J-153JE	1	435031534R1
PCB U005	R3302	C-CARBON R	RN72K1J-332JE	1	435033324R1
PCB U005	R3303	C-CARBON R	RN72K1J-104JE	1	435031044R1
PCB U005	R3304	C-CARBON R	RN72K1J-153JE	1	435031534R1
PCB U005	R3305	C-CARBON R	RN72K1J-153JE	1	435031534R1
PCB U005	R3306	C-CARBON R	RN72K1J-332JE	1	435033324R1
PCB U005	R3307	C-CARBON R	RN72K1J-104JE	1	435031044R1
PCB U005	R3308	C-CARBON R	RN72K1J-223JE	1	435032234R1
PCB U005	R3309	C-CARBON R	RN72K1J-332JE	1	435033324R1
PCB U005	R3310	C-CARBON R	RN72K1J-182JE	1	435031824R1
PCB U005	R3311	C-CARBON R	RN72K1J-471JE	1	435034714R1
PCB U005	R3312	C-CARBON R	RN72K1J-223JE	1	435032234R1
PCB U005	R3313	C-CARBON R	RN72K1J-152JE	1	435031524R1
PCB U005	R3314	C-CARBON R	RN72K1J-391JE	1	435033914R1
PCB U005	R3315	C-CARBON R	RN72K1J-560JE	1	435035604R1
PCB U005	R3401	C-R NET	RM7LJ330X04	1	43484733004R2
PCB U005	R3402	C-R NET	RM7LJ330X04	1	43484733004R2
PCB U005	R3403	C-R NET	RM7LJ330X04	1	43484733004R2
PCB U005	R3404	C-R NET	RM7LJ330X04	1	43484733004R2
PCB U005	R3405	C-CARBON R	RN72K1J-103JE	1	435031034R1
PCB U005	R3406	C-CARBON R	RN72K1J-103JE	1	435031034R1
PCB U005	R3407	C-CARBON R	RN72K1J-103JE	1	435031034R1
PCB U005	R3408	C-CARBON R	RN72K1J-103JE	1	435031034R1

PCB U005	R3409	C-CARBON R	RN72K1J-103JE	1	435031034R1
PCB U005	R3410	C-CARBON R	RN72K1J-221JE	1	435032214R1
PCB U005	R3411	C-CARBON R	RN72K1J-221JE	1	435032214R1
PCB U005	R3412	C-CARBON R	RN72K1J-470JE	1	435034704R1
PCB U005	R3413	C-CARBON R	RN72K1J-470JE	1	435034704R1
PCB U005	R3414	C-CARBON R	RN72K1J-470JE	1	435034704R1
PCB U005	R3416	C-CARBON R	RN72K1J-331JE	1	435033314R1
PCB U005	R3417	C-CARBON R	RN72K1J-330JE	1	435033304R1
PCB U005	R3418	C-CARBON R	RN72K1J-470JE	1	435034704R1
PCB U005	R3419	C-CARBON R	RN72K1J-750JE	1	435037504R1
PCB U005	R3420	C-CARBON R	RN72K1J-470JE	1	435034704R1
PCB U005	R3421	C-CARBON R	RN72K1J-102JE	1	435031024R1
PCB U005	R3422	C-CARBON R	RN72K1J-330JE	1	435033304R1
PCB U005	R3423	C-CARBON R	RN72K1J-470JE	1	435034704R1
PCB U005	R3424	C-CARBON R	RN72K1J-470JE	1	435034704R1
PCB U005	R3425	C-CARBON R	RN72K1J-470JE	1	435034704R1
PCB U005	R3426	C-R NET	RM7LJ330X04	1	43484733004R2
PCB U005	R3427	C-CARBON R	RN72K1J-470JE	1	435034704R1
PCB U005	R3428	C-CARBON R	RN72K1J-470JE	1	435034704R1
PCB U005	R3429	C-R NET	RM7LJ330X04	1	43484733004R2
PCB U005	R3430	C-R NET	RM7LJ330X04	1	43484733004R2
PCB U005	R3431	C-CARBON R	RN72K1J-103JE	1	435031034R1
PCB U005	R3432	C-CARBON R	RN72K1J-103JE	1	435031034R1
PCB U005	R3433	C-CARBON R	RN72K1J-103JE	1	435031034R1
PCB U005	R3435	C-R NET	RM7LJ330X04	1	43484733004R2
PCB U005	R3436	C-CARBON R	RN72K1J-331JE	1	435033314R1
PCB U005	R3437	C-CARBON R	RN72K1J-331JE	1	435033314R1
PCB U005	R3438	C-CARBON R	RN72K1J-331JE	1	435033314R1
PCB U005	R3439	C-R NET	RM7LJ330X04	1	43484733004R2
PCB U005	R3440	C-CARBON R	RN72K1J-331JE	1	435033314R1
PCB U005	R3441	C-CARBON R	RN72K1J-331JE	1	435033314R1
PCB U005	R3442	C-CARBON R	RN72K1J-331JE	1	435033314R1
PCB U005	R3443	C-CARBON R	RN72K1J-331JE	1	435033314R1
PCB U005	R3444	C-CARBON R	RN72K1J-331JE	1	435033314R1
PCB U005	R3445	C-R NET	RM7LJ330X04	1	43484733004R2
PCB U005	R3446	C-CARBON R	RN72K1J-470JE	1	435034704R1
PCB U005	R3447	C-CARBON R	RN72K1J-470JE	1	435034704R1
PCB U005	R3448	C-CARBON R	RN72K1J-470JE	1	435034704R1
PCB U005	R3449	C-CARBON R	RN72K1J-470JE	1	435034704R1
PCB U005	R3450	C-CARBON R	RN72K1J-470JE	1	435034704R1
PCB U005	R3451	C-CARBON R	RN72K1J-103JE	1	435031034R1



PCB U005	R3452	C-CARBON R	RN72K1J-103JE	1	435031034R1
PCB U005	R3453	C-CARBON R	RN72K1J-103JE	1	435031034R1
PCB U005	R3454	C-CARBON R	RN72K1J-470JE	1	435034704R1
PCB U005	R3455	C-CARBON R	RN72K1J-103JE	1	435031034R1
PCB U005	R3456	C-CARBON R	RN72K1J-470JE	1	435034704R1
PCB U005	R3457	C-CARBON R	RN72K1J-470JE	1	435034704R1
PCB U005	R3458	C-CARBON R	RN72K1J-470JE	1	435034704R1
PCB U005	R3459	C-CARBON R	RN72K1J-470JE	1	435034704R1
PCB U005	R3460	C-CARBON R	RN72K1J-470JE	1	435034704R1
PCB U005	R3461	C-CARBON R	RN72K1J-470JE	1	435034704R1
PCB U005	R3462	C-CARBON R	RN72K1J-470JE	1	435034704R1
PCB U005	R3464	C-CARBON R	RN72K1J-102JE	1	435031024R1
PCB U005	R3465	C-CARBON R	RN72K1J-223FE	1	435032232R1
PCB U005	R3466	C-CARBON R	RN72K1J-392FE	1	435033922R1
PCB U005	R3467	C-CARBON R	RN72K1J-224FE	1	435032242R1
PCB U005	R3468	C-CARBON R	RN72K1J-103FE	1	435031032R1
PCB U005	R3469	C-CARBON R	RN72K1J-333FE	1	435033332R1
PCB U005	R3470	C-CARBON R	RN72K1J-391JE	1	435033914R1
PCB U005	R3471	C-CARBON R	RN72K1J-391JE	1	435033914R1
PCB U005	R3472	C-CARBON R	RN72K1J-105JE	1	435031054R1
PCB U005	R3473	C-CARBON R	RN72K1J-000JE	1	435030004R1
PCB U005	R3570	C-CARBON R	RN72K1J-000JE	1	435030004R1
PCB U005	R3622	C-CARBON R	RN72K1J-000JE	1	435030004R1
PCB U005	R3623	C-CARBON R	RN72K1J-000JE	1	435030004R1
PCB U005	R3624	C-CARBON R	RN72K1J-000JE	1	435030004R1
PCB U005	R3625	C-CARBON R	RN72K1J-000JE	1	435030004R1
PCB U005	R3626	C-CARBON R	RN72K1J-000JE	1	435030004R1
PCB U005	R3627	C-CARBON R	RN72K1J-000JE	1	435030004R1
PCB U005	R3670	C-CARBON R	RN72K1J-103JE	1	435031034R1
PCB U005	R3671	C-CARBON R	RN72K1J-000JE	1	435030004R1
PCB U005	R3673	C-CARBON R	RN72K1J-000JE	1	435030004R1
PCB U005	R3674	C-CARBON R	RN72K1J-000JE	1	435030004R1
PCB U005	R8000	C-CARBON R	RN72K1J-103JE	1	435031034R1
PCB U005	R8001	C-CARBON R	RN72K1J-103JE	1	435031034R1
PCB U005	R8002	C-CARBON R	RN72K1J-271JE	1	435032714R1
PCB U005	R8003	C-CARBON R	RN72K1J-271JE	1	435032714R1
PCB U005	R8010	C-CARBON R	RN72K1J-103JE	1	435031034R1
PCB U005	R8011	C-CARBON R	RN72K1J-103JE	1	435031034R1
PCB U005	R8012	C-CARBON R	RN72K1J-000JE	1	435030004R1
PCB U005	R8013	C-CARBON R	RN72K1J-103JE	1	435031034R1
PCB U005	R8014	C-CARBON R	RN72K1J-103JE	1	435031034R1

PCB U005	R8015	C-CARBON R	RN72K1J-103JE	1	435031034R1
PCB U005	R8016	C-CARBON R	RN72K1J-103JE	1	435031034R1
PCB U005	R8017	C-CARBON R	RN72K1J-103JE	1	435031034R1
PCB U005	R8018	C-CARBON R	RN72K1J-103JE	1	435031034R1
PCB U005	R8019	C-CARBON R	RN72K1J-103JE	1	435031034R1
PCB U005	R8020	C-CARBON R	RN72K1J-103JE	1	435031034R1
PCB U005	R8021	C-CARBON R	RN72K1J-103JE	1	435031034R1
PCB U005	R8022	C-CARBON R	RN72K1J-103JE	1	435031034R1
PCB U005	R8026	C-CARBON R	RN72K1J-103JE	1	435031034R1
PCB U005	R8028	C-CARBON R	RN72K1J-103JE	1	435031034R1
PCB U005	R8029	C-CARBON R	RN72K1J-103JE	1	435031034R1
PCB U005	R8033	C-CARBON R	RN72K1J-103JE	1	435031034R1
PCB U005	R8034	C-CARBON R	RN72K1J-000JE	1	435030004R1
PCB U005	R8035	C-CARBON R	RN72K1J-000JE	1	435030004R1
PCB U005	R8036	C-CARBON R	RN72K1J-103JE	1	435031034R1
PCB U005	R8038	C-CARBON R	RN72K1J-330JE	1	435033304R1
PCB U005	R8045	C-CARBON R	RN72K1J-750JE	1	435037504R1
PCB U005	R8046	C-CARBON R	RN72K1J-750JE	1	435037504R1
PCB U005	R8047	C-CARBON R	RN72K1J-750JE	1	435037504R1
PCB U005	R8048	C-CARBON R	RN72K1J-750JE	1	435037504R1
PCB U005	R8049	C-CARBON R	RN72K1J-750JE	1	435037504R1
PCB U005	R8050	C-CARBON R	RN72K1J-750JE	1	435037504R1
PCB U005	R8051	C-CARBON R	RN72K1J-680JE	1	435036804R1
PCB U005	R8052	C-CARBON R	RN72K1J-471JE	1	435034714R1
PCB U005	R8053	C-CARBON R	RN72K1J-680JE	1	435036804R1
PCB U005	R8054	C-CARBON R	RN72K1J-471JE	1	435034714R1
PCB U005	R8055	C-CARBON R	RN72K1J-680JE	1	435036804R1
PCB U005	R8056	C-CARBON R	RN72K1J-471JE	1	435034714R1
PCB U005	R8057	C-CARBON R	RN72K1J-680JE	1	435036804R1
PCB U005	R8058	C-CARBON R	RN72K1J-471JE	1	435034714R1
PCB U005	R8059	C-CARBON R	RN72K1J-680JE	1	435036804R1
PCB U005	R8060	C-CARBON R	RN72K1J-680JE	1	435036804R1
PCB U005	R8061	C-CARBON R	RN72K1J-680JE	1	435036804R1
PCB U005	R8062	C-CARBON R	RN72K1J-220JE	1	435032204R1
PCB U005	R8063	C-CARBON R	RN72K1J-220JE	1	435032204R1
PCB U005	R8064	C-CARBON R	RN72K1J-220JE	1	435032204R1
PCB U005	R8065	C-CARBON R	RN72K1J-103JE	1	435031034R1
PCB U005	R8066	C-CARBON R	RN72K1J-103JE	1	435031034R1
PCB U005	R8067	C-CARBON R	RN72K1J-103JE	1	435031034R1
PCB U005	R8068	C-CARBON R	RN72K1J-750JE	1	435037504R1
PCB U005	R8069	C-CARBON R	RN72K1J-750JE	1	435037504R1

PCB U005	R8070	C-CARBON R	RN72K1J-750JE	1	435037504R1
PCB U005	R8071	C-CARBON R	RN72K1J-750JE	1	435037504R1
PCB U005	R8072	C-CARBON R	RN72K1J-750JE	1	435037504R1
PCB U005	R8073	C-CARBON R	RN72K1J-750JE	1	435037504R1
PCB U005	R8074	C-CARBON R	RN72K1J-103JE	1	435031034R1
PCB U005	R8075	C-CARBON R	RN72K1J-103JE	1	435031034R1
PCB U005	R8076	C-CARBON R	RN72K1J-103JE	1	435031034R1
PCB U005	R8079	C-CARBON R	RN72K1J-220JE	1	435032204R1
PCB U005	R8080	C-CARBON R	RN72K1J-220JE	1	435032204R1
PCB U005	R8081	C-CARBON R	RN72K1J-220JE	1	435032204R1
PCB U005	R8082	C-CARBON R	RN72K1J-680JE	1	435036804R1
PCB U005	R8083	C-CARBON R	RN72K1J-471JE	1	435034714R1
PCB U005	R8084	C-CARBON R	RN72K1J-471JE	1	435034714R1
PCB U005	R8085	C-CARBON R	RN72K1J-471JE	1	435034714R1
PCB U005	R8086	C-CARBON R	RN72K1J-471JE	1	435034714R1
PCB U005	R8087	C-CARBON R	RN72K1J-220JE	1	435032204R1
PCB U005	R8088	C-CARBON R	RN72K1J-220JE	1	435032204R1
PCB U005	R8089	C-CARBON R	RN72K1J-102JE	1	435031024R1
PCB U005	R8090	C-CARBON R	RN72K1J-102JE	1	435031024R1
PCB U005	R8154	C-CARBON R	RN72K1J-000JE	1	435030004R1
PCB U005	R8160	C-CARBON R	RN72K1J-332JE	1	435033324R1
PCB U005	R8161	C-CARBON R	RN72K1J-681JE	1	435036814R1
PCB U005	R8162	C-CARBON R	RN72K1J-101JE	1	435031014R1
PCB U005	R8165	C-CARBON R	RN72K1J-103JE	1	435031034R1
PCB U005	R8201	C-CARBON R	RN72K1J-330JE	1	435033304R1
PCB U005	R8202	C-CARBON R	RN72K1J-000JE	1	435030004R1
PCB U005	R8203	C-CARBON R	RN72K1J-000JE	1	435030004R1
PCB U005	R8205	C-CARBON R	RN72K1J-220JE	1	435032204R1
PCB U005	R8206	C-CARBON R	RN72K1J-103JE	1	435031034R1
PCB U005	R8207	C-CARBON R	RN72K1J-103JE	1	435031034R1
PCB U005	R8208	C-CARBON R	RN72K1J-103JE	1	435031034R1
PCB U005	R8209	C-CARBON R	RN72K1J-103JE	1	435031034R1
PCB U005	R8210	C-CARBON R	RN72K1J-103JE	1	435031034R1
PCB U005	R8212	C-CARBON R	RN72K1J-103JE	1	435031034R1
PCB U005	R8213	C-CARBON R	RN72K1J-103JE	1	435031034R1
PCB U005	R8214	C-CARBON R	RN72K1J-272JE	1	435032724R1
PCB U005	R8215	C-CARBON R	RN72K1J-272JE	1	435032724R1
PCB U005	R8219	C-CARBON R	RN72K1J-103JE	1	435031034R1
PCB U005	R8223	C-CARBON R	RN72K1J-103JE	1	435031034R1
PCB U005	R8224	C-CARBON R	RN72K1J-103JE	1	435031034R1
PCB U005	R8230	C-R NET	RM7LJ330X04	1	43484733004R2

PCB U005	R8231	C-R NET	RM7LJ330X04	1	43484733004R2
PCB U005	R8232	C-R NET	RM7LJ330X04	1	43484733004R2
PCB U005	R8233	C-R NET	RM7LJ330X04	1	43484733004R2
PCB U005	R8234	C-R NET	RM7LJ330X04	1	43484733004R2
PCB U005	R8235	C-R NET	RM7LJ330X04	1	43484733004R2
PCB U005	R8236	C-R NET	RM7LJ330X04	1	43484733004R2
PCB U005	R8238	C-R NET	RM7LJ330X04	1	43484733004R2
PCB U005	R8239	C-R NET	RM7LJ330X04	1	43484733004R2
PCB U005	R8240	C-R NET	RM7LJ330X04	1	43484733004R2
PCB U005	R8241	C-R NET	RM7LJ330X04	1	43484733004R2
PCB U005	R8243	C-R NET	RM7LJ330X04	1	43484733004R2
PCB U005	R8245	C-R NET	RM7LJ330X04	1	43484733004R2
PCB U005	R8248	C-R NET	RM7LJ330X04	1	43484733004R2
PCB U005	R8249	C-R NET	RM7LJ330X04	1	43484733004R2
PCB U005	R8251	C-R NET	RM7LJ220X04	1	43484722004R2
PCB U005	R8252	C-R NET	RM7LJ220X04	1	43484722004R2
PCB U005	R8253	C-R NET	RM7LJ220X04	1	43484722004R2
PCB U005	R8254	C-R NET	RM7LJ220X04	1	43484722004R2
PCB U005	R8255	C-R NET	RM7LJ220X04	1	43484722004R2
PCB U005	R8256	C-R NET	RM7LJ220X04	1	43484722004R2
PCB U005	R8257	C-R NET	RM7LJ220X04	1	43484722004R2
PCB U005	R8258	C-R NET	RM7LJ220X04	1	43484722004R2
PCB U005	R8259	C-R NET	RM7LJ220X04	1	43484722004R2
PCB U005	R8264	C-CARBON R	RN72K1J-103JE	1	435031034R1
PCB U005	R8271	C-R NET	RM7LJ220X04	1	43484722004R2
PCB U005	R8272	C-R NET	RM7LJ220X04	1	43484722004R2
PCB U005	R8273	C-R NET	RM7LJ220X04	1	43484722004R2
PCB U005	R8274	C-R NET	RM7LJ220X04	1	43484722004R2
PCB U005	R8275	C-R NET	RM7LJ220X04	1	43484722004R2
PCB U005	R8276	C-R NET	RM7LJ220X04	1	43484722004R2
PCB U005	R8277	C-R NET	RM7LJ220X04	1	43484722004R2
PCB U005	R8278	C-R NET	RM7LJ220X04	1	43484722004R2
PCB U005	R8279	C-R NET	RM7LJ220X04	1	43484722004R2
PCB U005	R8280	C-CARBON R	RN72K1J-120JE	1	435031204R1
PCB U005	R8284	C-CARBON R	RN72K1J-120JE	1	435031204R1
PCB U005	R8323	C-CARBON R	RN72K1J-103JE	1	435031034R1
PCB U005	R8329	C-CARBON R	RN72K1J-473JE	1	435034734R1
PCB U005	R8330	C-CARBON R	RN72K1J-473JE	1	435034734R1
PCB U005	R8333	C-CARBON R	RN72K1J-103JE	1	435031034R1
PCB U005	R8334	C-CARBON R	RN72K1J-222JE	1	435032224R1
PCB U005	R8335	C-CARBON R	RN72K1J-222JE	1	435032224R1

PCB U005	R8336	C-CARBON R	RN72K1J-472JE	1	435034724R1
PCB U005	R8337	C-CARBON R	RN72K1J-473JE	1	435034734R1
PCB U005	R8338	C-CARBON R	RN72K1J-473JE	1	435034734R1
PCB U005	R8339	C-CARBON R	RN72K2E-470JE	1	435224704R1
PCB U005	R8343	C-CARBON R	RN72K1J-103JE	1	435031034R1
PCB U005	R8349	C-CARBON R	RN72K1J-473JE	1	435034734R1
PCB U005	R8350	C-CARBON R	RN72K1J-473JE	1	435034734R1
PCB U005	R8360	C-CARBON R	RN72K1J-103JE	1	435031034R1
PCB U005	R8361	C-CARBON R	RN72K1J-681JE	1	435036814R1
PCB U005	R8362	C-CARBON R	RN72K1J-101JE	1	435031014R1
PCB U005	R8365	C-CARBON R	RN72K1J-103JE	1	435031034R1
PCB U005	R8372	C-CARBON R	RN72K1J-103JE	1	435031034R1
PCB U005	R8374	C-CARBON R	RN72K1J-472JE	1	435034724R1
PCB U005	R8375	C-CARBON R	RN72K1J-473JE	1	435034734R1
PCB U005	R8376	C-CARBON R	RN72K1J-473JE	1	435034734R1
PCB U005	R8384	C-CARBON R	RN72K1J-222JE	1	435032224R1
PCB U005	R8385	C-CARBON R	RN72K1J-222JE	1	435032224R1
PCB U005	R8391	C-CARBON R	RN72K2E-470JE	1	435224704R1
PCB U005	R8401	C-R NET	RM7LJ220X04	1	43484722004R2
PCB U005	R8402	C-CARBON R	RN72K1J-220JE	1	435032204R1
PCB U005	R8403	C-R NET	RM7LJ220X04	1	43484722004R2
PCB U005	R8404	C-CARBON R	RN72K1J-220JE	1	435032204R1
PCB U005	R8405	C-CARBON R	RN72K1J-220JE	1	435032204R1
PCB U005	R8408	C-CARBON R	RN72K1J-220JE	1	435032204R1
PCB U005	R8409	C-CARBON R	RN72K1J-101JE	1	435031014R1
PCB U005	R8410	C-CARBON R	RN72K1J-681JE	1	435036814R1
PCB U005	R8411	C-CARBON R	RN72K1J-472JE	1	435034724R1
PCB U005	R8416	C-R NET	RM7LJ220X04	1	43484722004R2
PCB U005	R8417	C-R NET	RM7LJ220X04	1	43484722004R2
PCB U005	R8418	C-R NET	RM7LJ220X04	1	43484722004R2
PCB U005	R8419	C-R NET	RM7LJ220X04	1	43484722004R2
PCB U005	R8420	C-R NET	RM7LJ220X04	1	43484722004R2
PCB U005	R8421	C-R NET	RM7LJ220X04	1	43484722004R2
PCB U005	R8422	C-R NET	RM7LJ220X04	1	43484722004R2
PCB U005	R8423	C-R NET	RM7LJ220X04	1	43484722004R2
PCB U005	R8424	C-R NET	RM7LJ220X04	1	43484722004R2
PCB U005	R8425	C-CARBON R	RN72K1J-220JE	1	435032204R1
PCB U005	R8429	C-CARBON R	RN72K1J-220JE	1	435032204R1
PCB U005	R8431	C-CARBON R	RN72K1J-472JE	1	435034724R1
PCB U005	R8432	C-CARBON R	RN72K1J-220JE	1	435032204R1
PCB U005	R8442	C-CARBON R	RN72K1J-102JE	1	435031024R1

PCB U005	R8451	C-R NET	RM7LJ220X04	1	43484722004R2
PCB U005	R8452	C-CARBON R	RN72K1J-220JE	1	435032204R1
PCB U005	R8453	C-R NET	RM7LJ220X04	1	43484722004R2
PCB U005	R8454	C-CARBON R	RN72K1J-220JE	1	435032204R1
PCB U005	R8455	C-CARBON R	RN72K1J-220JE	1	435032204R1
PCB U005	R8458	C-CARBON R	RN72K1J-220JE	1	435032204R1
PCB U005	R8459	C-CARBON R	RN72K1J-101JE	1	435031014R1
PCB U005	R8460	C-CARBON R	RN72K1J-681JE	1	435036814R1
PCB U005	R8462	C-CARBON R	RN72K1J-472JE	1	435034724R1
PCB U005	R8466	C-R NET	RM7LJ220X04	1	43484722004R2
PCB U005	R8467	C-R NET	RM7LJ220X04	1	43484722004R2
PCB U005	R8468	C-R NET	RM7LJ220X04	1	43484722004R2
PCB U005	R8469	C-R NET	RM7LJ220X04	1	43484722004R2
PCB U005	R8470	C-R NET	RM7LJ220X04	1	43484722004R2
PCB U005	R8471	C-R NET	RM7LJ220X04	1	43484722004R2
PCB U005	R8472	C-R NET	RM7LJ220X04	1	43484722004R2
PCB U005	R8473	C-R NET	RM7LJ220X04	1	43484722004R2
PCB U005	R8474	C-R NET	RM7LJ220X04	1	43484722004R2
PCB U005	R8475	C-CARBON R	RN72K1J-220JE	1	435032204R1
PCB U005	R8479	C-CARBON R	RN72K1J-220JE	1	435032204R1
PCB U005	R8481	C-CARBON R	RN72K1J-472JE	1	435034724R1
PCB U005	R8482	C-CARBON R	RN72K1J-220JE	1	435032204R1
PCB U005	R8492	C-CARBON R	RN72K1J-102JE	1	435031024R1
PCB U005	R8501	C-CARBON R	RN72K1J-000JE	1	435030004R1
PCB U005	R8502	C-CARBON R	RN72K1J-120JE	1	435031204R1
PCB U005	R8503	C-R NET	RM7LJ000X04	1	43484700004R2
PCB U005	R8504	C-R NET	RM7LJ330X04	1	43484733004R2
PCB U005	R8505	C-R NET	RM7LJ000X04	1	43484700004R2
PCB U005	R8507	C-R NET	RM7LJ000X04	1	43484700004R2
PCB U005	R8508	C-R NET	RM7LJ000X04	1	43484700004R2
PCB U005	R8509	C-R NET	RM7LJ000X04	1	43484700004R2
PCB U005	R8510	C-R NET	RM7LJ000X04	1	43484700004R2
PCB U005	R8511	C-R NET	RM7LJ000X04	1	43484700004R2
PCB U005	R8512	C-R NET	RM7LJ000X04	1	43484700004R2
PCB U005	R8513	C-R NET	RM7LJ000X04	1	43484700004R2
PCB U005	R8516	C-CARBON R	RN72K1J-101JE	1	435031014R1
PCB U005	R8517	C-CARBON R	RN72K1J-101JE	1	435031014R1
PCB U005	R8518	C-CARBON R	RN72K1J-472JE	1	435034724R1
PCB U005	R8519	C-CARBON R	RN72K1J-151JE	1	435031514R1
PCB U005	R8522	C-R NET	RM7LJ330X04	1	43484733004R2
PCB U005	R8523	C-CARBON R	RN72K1J-330JE	1	435033304R1

PCB U005	R8524	C-CARBON R	RN72K1J-330JE	1	435033304R1
PCB U005	R8525	C-CARBON R	RN72K1J-472JE	1	435034724R1
PCB U005	R8526	C-CARBON R	RN72K1J-472JE	1	435034724R1
PCB U005	R8527	C-CARBON R	RN72K1J-562JE	1	435035624R1
PCB U005	R8528	C-CARBON R	RN72K1J-562JE	1	435035624R1
PCB U005	R8529	C-CARBON R	RN72K1J-103JE	1	435031034R1
PCB U005	R8530	C-CARBON R	RN72K1J-105JE	1	435031054R1
PCB U005	R8531	C-CARBON R	RN72K1J-000JE	1	435030004R1
PCB U005	R8533	C-CARBON R	RN72K1J-562JE	1	435035624R1
PCB U005	R8534	C-CARBON R	RN72K1J-562JE	1	435035624R1
PCB U005	R8535	C-CARBON R	RN72K1J-000JE	1	435030004R1
PCB U005	R8536	C-CARBON R	RN72K1J-000JE	1	435030004R1
PCB U005	R8601	C-CARBON R	RN72K1J-000JE	1	435030004R1
PCB U005	R8602	C-CARBON R	RN72K1J-000JE	1	435030004R1
PCB U005	R8607	C-CARBON R	RN72K1J-473JE	1	435034734R1
PCB U005	R8608	C-CARBON R	RN72K1J-473JE	1	435034734R1
PCB U005	R8609	C-CARBON R	RN72K1J-000JE	1	435030004R1
PCB U005	R8617	C-CARBON R	RN72K1J-473JE	1	435034734R1
PCB U005	R8618	C-CARBON R	RN72K1J-473JE	1	435034734R1
PCB U005	R8619	C-CARBON R	RN72K1J-103JE	1	435031034R1
PCB U005	R8627	C-CARBON R	RN72K1J-473JE	1	435034734R1
PCB U005	R8628	C-CARBON R	RN72K1J-473JE	1	435034734R1
PCB U005	R8629	C-CARBON R	RN72K1J-103JE	1	435031034R1
PCB U005	R8637	C-CARBON R	RN72K1J-473JE	1	435034734R1
PCB U005	R8638	C-CARBON R	RN72K1J-473JE	1	435034734R1
PCB U005	R8639	C-CARBON R	RN72K1J-103JE	1	435031034R1
PCB U005	R8647	C-CARBON R	RN72K1J-472JE	1	435034724R1
PCB U005	R8648	C-CARBON R	RN72K1J-472JE	1	435034724R1
PCB U005	R8649	C-CARBON R	RN72K1J-000JE	1	435030004R1
PCB U005	R8650	C-CARBON R	RN72K1J-000JE	1	435030004R1
PCB U005	R8651	C-CARBON R	RN72K1J-000JE	1	435030004R1
PCB U005	R8654	C-CARBON R	RN72K1J-223JE	1	435032234R1
PCB U005	R8655	C-CARBON R	RN72K1J-224JE	1	435032244R1
PCB U005	R8656	C-CARBON R	RN72K1J-333JE	1	435033334R1
PCB U005	R8701	C-CARBON R	RN72K1J-103JE	1	435031034R1
PCB U005	R8702	C-CARBON R	RN72K1J-103JE	1	435031034R1
PCB U005	R8703	C-CARBON R	RN72K1J-103JE	1	435031034R1
PCB U005	R8705	C-CARBON R	RN72K1J-220JE	1	435032204R1
PCB U005	R8706	C-CARBON R	RN72K1J-220JE	1	435032204R1
PCB U005	R8707	C-CARBON R	RN72K1J-220JE	1	435032204R1
PCB U005	R8708	C-CARBON R	RN72K1J-103JE	1	435031034R1

PCB U005	R8709	C-CARBON R	RN72K1J-103JE	1	435031034R1
PCB U005	R8710	C-CARBON R	RN72K1J-103JE	1	435031034R1
PCB U005	R8711	C-CARBON R	RN72K1J-222JE	1	435032224R1
PCB U005	R8712	C-R NET	RM7LJ222X04	1	43484722204R2
PCB U005	R8713	C-R NET	RM7LJ222X04	1	43484722204R2
PCB U005	R8714	C-R NET	RM7LJ222X04	1	43484722204R2
PCB U005	R8715	C-R NET	RM7LJ103X04	1	43484710304R2
PCB U005	R8716	C-CARBON R	RN72K1J-103JE	1	435031034R1
PCB U005	R8717	C-CARBON R	RN72K1J-103JE	1	435031034R1
PCB U005	R8718	C-CARBON R	RN72K1J-220JE	1	435032204R1
PCB U005	R8719	C-CARBON R	RN72K1J-103JE	1	435031034R1
PCB U005	R8720	C-CARBON R	RN72K1J-220JE	1	435032204R1
PCB U005	R8721	C-CARBON R	RN72K1J-220JE	1	435032204R1
PCB U005	R8722	C-CARBON R	RN72K1J-103JE	1	435031034R1
PCB U005	R8723	C-CARBON R	RN72K1J-103JE	1	435031034R1
PCB U005	R8733	C-CARBON R	RN72K1J-103JE	1	435031034R1
PCB U005	R8742	C-CARBON R	RN72K1J-103JE	1	435031034R1
PCB U005	R8744	C-CARBON R	RN72K1J-103JE	1	435031034R1
PCB U005	R8745	C-CARBON R	RN72K1J-103JE	1	435031034R1
PCB U005	R8747	C-CARBON R	RN72K1J-103JE	1	435031034R1
PCB U005	R8749	C-CARBON R	RN72K1J-220JE	1	435032204R1
PCB U005	R8750	C-CARBON R	RN72K1J-000JE	1	435030004R1
PCB U005	R8751	C-CARBON R	RN72K1J-000JE	1	435030004R1
PCB U005	R8752	C-CARBON R	RN72K1J-000JE	1	435030004R1
PCB U005	R8801	C-R NET	RM7LJ220X04	1	43484722004R2
PCB U005	R8802	C-R NET	RM7LJ220X04	1	43484722004R2
PCB U005	R8803	C-R NET	RM7LJ220X04	1	43484722004R2
PCB U005	R8804	C-R NET	RM7LJ220X04	1	43484722004R2
PCB U005	R8805	C-R NET	RM7LJ220X04	1	43484722004R2
PCB U005	R8806	C-CARBON R	RN72K1J-103JE	1	435031034R1
PCB U005	R8810	C-R NET	RM7LJ220X04	1	43484722004R2
PCB U005	R8811	C-R NET	RM7LJ220X04	1	43484722004R2
PCB U005	R8812	C-R NET	RM7LJ220X04	1	43484722004R2
PCB U005	R8813	C-CARBON R	RN72K1J-220JE	1	435032204R1
PCB U005	R8814	C-CARBON R	RN72K1J-181JE	1	435031814R1
PCB U005	R8815	C-CARBON R	RN72K1J-332JE	1	435033324R1
PCB U005	R8816	C-CARBON R	RN72K1J-181JE	1	435031814R1
PCB U005	R8817	C-CARBON R	RN72K1J-332JE	1	435033324R1
PCB U005	R8818	C-CARBON R	RN72K1J-332JE	1	435033324R1
PCB U005	R8819	C-CARBON R	RN72K1J-821JE	1	435038214R1
PCB U005	R8820	C-CARBON R	RN72K1J-332JE	1	435033324R1



PCB U005	R8821	C-CARBON R	RN72K1J-821JE	1	435038214R1
PCB U005	R8822	C-CARBON R	RN72K1J-473JE	1	435034734R1
PCB U005	R8823	C-CARBON R	RN72K1J-000JE	1	435030004R1
PCB U005	R8824	C-CARBON R	RN72K1J-000JE	1	435030004R1
PCB U005	R8901	C-CARBON R	RN72K1J-122JE	1	435031224R1
PCB U005	R8902	C-CARBON R	RN72K1J-122JE	1	435031224R1
PCB U005	R8903	C-CARBON R	RN72K1J-122JE	1	435031224R1
PCB U005	R8904	C-CARBON R	RN72K1J-122JE	1	435031224R1
PCB U005	R8905	C-CARBON R	RN72K1J-122JE	1	435031224R1
PCB U005	R8906	C-CARBON R	RN72K1J-122JE	1	435031224R1
PCB U005	R8907	C-CARBON R	RN72K1J-122JE	1	435031224R1
PCB U005	R8908	C-CARBON R	RN72K1J-122JE	1	435031224R1
PCB U005	R8909	C-CARBON R	RN72K1J-122JE	1	435031224R1
PCB U005	R8910	C-CARBON R	RN72K1J-122JE	1	435031224R1
PCB U005	R8911	C-CARBON R	RN72K1J-122JE	1	435031224R1
PCB U005	R8912	C-CARBON R	RN72K1J-122JE	1	435031224R1
PCB U005	R8913	C-CARBON R	RN72K1J-122JE	1	435031224R1
PCB U005	R8914	C-CARBON R	RN72K1J-122JE	1	435031224R1
PCB U005	R8915	C-CARBON R	RN72K1J-122JE	1	435031224R1
PCB U005	R8916	C-CARBON R	RN72K1J-122JE	1	435031224R1
PCB U005	R8917	C-CARBON R	RN72K1J-122JE	1	435031224R1
PCB U005	R8918	C-CARBON R	RN72K1J-122JE	1	435031224R1
PCB U005	R8919	C-CARBON R	RN72K1J-122JE	1	435031224R1
PCB U005	R8920	C-CARBON R	RN72K1J-122JE	1	435031224R1
PCB U005	R8921	C-CARBON R	RN72K1J-122JE	1	435031224R1
PCB U005	R8922	C-CARBON R	RN72K1J-122JE	1	435031224R1
PCB U005	R8923	C-CARBON R	RN72K1J-122JE	1	435031224R1
PCB U005	R8924	C-CARBON R	RN72K1J-122JE	1	435031224R1
PCB U005	R8937	C-CARBON R	RN72K1J-103JE	1	435031034R1
PCB U005	R8951	C-CARBON R	RN72K1J-103JE	1	435031034R1
PCB U005	R8952	C-CARBON R	RN72K1J-683JE	1	435036834R1
PCB U005	R8953	C-CARBON R	RN72K1J-183FE	1	435031832R1
PCB U005	R8954	C-CARBON R	RN72K1J-224FE	1	435032242R1
PCB U005	R8955	C-CARBON R	RN72K1J-103FE	1	435031032R1
PCB U005	R8957	C-CARBON R	RN72K1J-333JE	1	435033334R1
PCB U005	R8958	C-CARBON R	RN72K1J-333FE	1	435033332R1
PCB U005	R8959	C-CARBON R	RN72K1J-562FE	1	435035622R1
PCB U005	R8960	C-CARBON R	RN72K1J-103FE	1	435031032R1
PCB U005	R8962	C-CARBON R	RN72K1J-333JE	1	435033334R1
PCB U005	R8963	C-CARBON R	RN72K1J-153FE	1	435031532R1
PCB U005	R8964	C-CARBON R	RN72K1J-333FE	1	435033332R1

PCB U005	R8965	C-CARBON R	RN72K1J-103FE	1	435031032R1	
PCB U005	R8967	C-CARBON R	RN72K1J-683JE	1	435036834R1	
PCB U005	R8968	C-CARBON R	RN72K1J-333FE	1	435033332R1	
PCB U005	R8969	C-CARBON R	RN72K1J-394FE	1	435033942R1	
PCB U005	R8970	C-CARBON R	RN72K1J-103FE	1	435031032R1	
PCB U005	R8971	C-CARBON R	RN72K1J-473JE	1	435034734R1	
PCB U005	R8972	C-CARBON R	RN72K1J-103JE	1	435031034R1	
PCB U005	R8973	C-CARBON R	RN72K1J-103JE	1	435031034R1	
PCB U005	R8974	C-CARBON R	RN72K1J-103JE	1	435031034R1	
PCB U005	R8976	C-CARBON R	RN72K1J-103JE	1	435031034R1	
PCB U005	R8977	C-CARBON R	RN72K1J-562JE	1	435035624R1	
PCB U005	R8978	C-CARBON R	RN72K1J-682JE	1	435036824R1	
PCB U005	R8979	C-CARBON R	RN72K1J-562JE	1	435035624R1	
PCB U005	[SW TRM]					
PCB U005	JL3201	WIRE TRAP	NPLG-5P588	1	25055626	
PCB U005	JL8002B	SOCKET	NSCT-5P97	1	25050269	
PCB U005	P005	PWB	BCHDM-0132	1	25140132C	N
PCB U005	P3001	SOCKET(B to B)	IMSA-9850S-20Y900	1	25052813R2	
PCB U005	P3101A	PLUG	NPLG-5P918	1	25055965R2	
PCB U005	P3102A	SOCKET	NSCT-9P2472	1	25052575R2	
PCB U005	P3104	SOCKET	SI-60073-F	1	25053307	
PCB U005	P3104 or	SOCKET	J0026D21NL	(1)	25053250	
PCB U005	P3605A	PLUG	IMSA-9142B-18A	1	25056599	
PCB U005	P3607A	PLUG	IMSA-9142B-16A	1	25056598	
PCB U005	P3608A	PLUG	IMSA-9142B-18A	1	25056599	
PCB U005	P3609	SOCKET	04FMN-SMT-A-TF	1	25052821R2	
PCB U005	P4104A	SOCKET	NSCT-31P2124	1	25052227	
PCB U005	P8005A	TRM-423(SCREW)	NEJITANSI ST3	1	25060495	
PCB U005	P8006	HOLDER	(CLUMP) UA-0	1	27190432	
PCB U005	P8302	SOCKET	YKF45-7037V	1	25053253R3	
PCB U005	P8321	SOCKET	YKF45-7037V	1	25053253R3	
PCB U005	P8341	SOCKET	YKF45-7037V	1	25053253R3	
PCB U005	P8352	SOCKET	YKF45-7037V	1	25053253R3	
PCB U005	P8601	SOCKET	YKF45-7037V	1	25053253R3	
PCB U005	P8611	SOCKET	YKF45-7037V	1	25053253R3	
PCB U005	P8621	SOCKET	YKF45-7037V	1	25053253R3	
PCB U005	P8631	SOCKET	YKF45-7037V	1	25053253R3	
PCB U005	P8641B	SOCKET	FX16-31S-0.5SH	1	25053365R2	
PCB U005	P8702	SOCKET	NSCT-9P2472	1	25052575R2	
PCB U005	P8704	SOCKET	04FMN-SMT-A-TF	1	25052821R2	

PCB U006 **U0061** FRONT HDMI TERMINAL PC BOARD (BAHDM-0291-1B)

PCB U006	CIRCUIT. NO.	PART NAME	DESCRIPTION	Q'TY	PART NO. (SN)	REMARKS
PCB U006		<b>[SEMI CONDUCTOR]</b>				
PCB U006	D3300	C-DIODE	KDS4148U	1	223283R2	
PCB U006	D3300 or	C-DIODE	1SS352	(1)	223234R2	
PCB U006	D3301	C-DIODE	KDS4148U	1	223283R2	
PCB U006	D3301 or	C-DIODE	1SS352	(1)	223234R2	
PCB U006	D8861	C-DIODE	KDS4148U	1	223283R2	
PCB U006	D8861 or	C-DIODE	1SS352	(1)	223234R2	
PCB U006	D8862	C-DIODE	KDS4148U	1	223283R2	
PCB U006	D8862 or	C-DIODE	1SS352	(1)	223234R2	
PCB U006	Q3300	IC	TPD2E001DRLR	1	22242589R2	
PCB U006	Q8861	IC	TMDS141RHARG4	1	22242586R2	
PCB U006		<b>[TRANS COIL]</b>				
PCB U006	L8861	CORE	BLM18PG181SN1D	1	2350005R1	
PCB U006		<b>[CAPACITOR]</b>				
PCB U006	C3302	C-FILM C	ECHU16V-104J	1	373041044R2	
PCB U006	C3303	C-FILM C	ECHU16V-104J	1	373041044R2	
PCB U006	C3304	C-CERA C	CK725F1A-105Z1	1	332181050R1	
PCB U006	C8861	C-FILM C	ECHU16V-104J	1	373041044R2	
PCB U006	C8863	C-CERA C	CK725F1A-105Z1	1	332181050R1	
PCB U006	C8864	C-CERA C	CK725B1H-102K1	1	332101025R1	
PCB U006	C8869	C-CERA C	CK725F1A-105Z1	1	332181050R1	
PCB U006	C8870	C-CERA C	CK725B1H-102K1	1	332101025R1	
PCB U006	C8871	C-CERA C	CK725F1A-105Z1	1	332181050R1	
PCB U006	C8872	C-CERA C	CK725B1H-102K1	1	332101025R1	
PCB U006	C8873	C-CERA C	CK725F1A-105Z1	1	332181050R1	
PCB U006	C8874	C-CERA C	CK725B1H-102K1	1	332101025R1	
PCB U006	C8875	C-CERA C	CK725F1A-105Z1	1	332181050R1	
PCB U006	C8876	C-CERA C	CK725B1H-102K1	1	332101025R1	
PCB U006	C8877	C-CERA C	CK725B0J-106K	1	332091065R2	
PCB U006	C8880	C-CERA C	CK725B0J-106K	1	332091065R2	
PCB U006		<b>[RESISTOR]</b>				
PCB U006	R3331	C-CARBON R	RN72K1J-000JE	1	435030004R1	
PCB U006	R8867	C-CARBON R	RN72K1J-473JE	1	435034734R1	
PCB U006	R8868	C-CARBON R	RN72K1J-473JE	1	435034734R1	
PCB U006	R8869	C-CARBON R	RN72K1J-000JE	1	435030004R1	
PCB U006	R8870	C-CARBON R	RN72K1J-000JE	1	435030004R1	
PCB U006	R8872	C-CARBON R	RN72K1J-103JE	1	435031034R1	
PCB U006	R8873	C-CARBON R	RN72K1J-472JE	1	435034724R1	

PCB U006	R8874	C-CARBON R	RN72K1J-103JE	1	435031034R1	
PCB U006	R8875	C-CARBON R	RN72K1J-103JE	1	435031034R1	
PCB U006	R8876	C-CARBON R	RN72K1J-103JE	1	435031034R1	
PCB U006	R8880	C-CARBON R	RN72K1J-000JE	1	435030004R1	
PCB U006	R8881	C-CARBON R	RN72K1J-000JE	1	435030004R1	
PCB U006	[SW TRM]					
PCB U006	E8861	TRM	NTM-1P233(M1969)	1	25060302	
PCB U006	P010	PWB	BCHDM-0290	1	25140290B	N
PCB U006	P011	PWB	BCHDM-0291	{ 1 }	25140291	
PCB U006	P3101C	PLUG	NPLG-5P918	1	25055965R2	
PCB U006	P3305	SOCKET	YKF45-0029N	1	25053242	
PCB U006	P8641D	SOCKET	FX16-31S-0.5SV	1	25053354R2	
PCB U006	P8861	SOCKET	YKF45-7037V	1	25053253R3	

**DTR-50.1**

**PACKING PROCEDURE PARTS LIST**

	REF. NO.	PART NAME	DESCRIPTION	Q'TY	PART NO. (SN)	REMARKS
PACKING	[PACKING]					
PACKING	A651	PAD	AS807	1	29092465A	807/50.1
PACKING	A655	SHEET	(ACC)	1	29096104	807/50.1
PACKING	A657	SHEET	T0.515 x 1300 x 900	1	29096066	
PACKING	A661	POLY BAG	(W1020 x D770)	1	29100253	807/50.1_SET
PACKING	A663	TAPE	(SEROHAN)NITTO NO.29	1	29110149	:0.3:MT::
PACKING	A665	PP TAPE	W50 SBT-70	1	29110200	:1.6:MT::
PACKING	A667	STAPLE	FUKAN-BARI(1000KO)	4	282321	
PACKING	A669	LABEL	(MMA)	2	29390973	<MMA>
PACKING	A701	CARTON	DTR-50.1(B)MDD	1	29055011B	N △D Change
PACKING	A703A	UPC LABEL	DTR-50.1(B)	1	29390817	N <MDD>
PACKING	A703A	EAN LABEL	DTR-50.1(B)	1	29390818	N <MMA>
PACKING	[ACCESSARY]					
PACKING	A801	LABEL	(SPCABLE)2009	1	29390881	
PACKING	A810	BATTERY	R6/AA(UM-3)	2	3010194	
PACKING	A810or	BATTERY	R6/AA(UM-3)	( 2 )	3010054	
PACKING	A811	REMO CON	RC-746M	1	24140746	N
PACKING	A812	ANT COIL	NMA-3057	1	232140	
PACKING	A813	FM ANT AS	Type W	1	292191	
PACKING	A814	MIC	MIC-7000	1	245044	
PACKING	A820	TAPE	(SEROHAN)NITTO NO.29	1	29110149	0.02MT
PACKING	A821	POLY BAG	w250 x d350	1	29100250A	Manual,ACC

PACKING	A847	INST SHEET	WINDOWS7	1	29355775	
PACKING	A859	WRNTY CARD	(INTEGRA)	1	29365136	<MDD>
PACKING	A861	INS MANUAL	En(DTR-50.1)	1	29400038	N
PACKING	A871	INS MANUAL	En(QSS)(DTR-50.1)	1	29400040	N
PACKING	A875	INS MANUAL	U9(RC736/737/738/739)	1	29344962	
PACKING	A876	INS MANUAL	U2JaEn(Software_807/HT-RC180)	1	29400164	
PACKING	A877	INS MANUAL	En(Pand/Rhap/InterSir_INTE)	1	29400168	<MDD>
PACKING	A881	INST SHEET	WEEE	1	29355537A	<MMA>
PACKING	A882	HANDBILL	(SIRIUS)	1	29380149	<MDD>
PACKING	A883	INST SHEET	En(2009E_RIHD)	1	29355745	
PACKING	A890	HANDBILL	(UP-A1)US	1	29380155	<MDD>
PACKING	P901	AC CORD	AS-UC-2	1	253352ATES	!, <MDD>
PACKING	P901or	AC CORD	AS-UC-2	( 1)	253297KAW	!, <MDD>
PACKING	P901	AC CORD	AS-SAA	1	253391VOL	!, <MMA>

807/180

50.1DD,MA/DHC DD

---

Integra Division of

**ONKYO CORPORATION**

Service Dept. Technical Support : 2-1, Nisshin-cho, Neyagawa-shi, OSAKA 572-8540, JAPAN

Tel: 072-831-8023 Fax: 072-831-8163 <http://www.onkyo.com/>

Integra Division of

**ONKYO U.S.A. CORPORATION**

18 Park Way, Upper Saddle River, N.J. 07458, U.S.A.

Tel: 201-785-2600 Fax: 201-785-2650 <http://www.integrahometheater.com>