

SERVICE

MANUAL

2 C H P O W E R E D

MIXER

CA-6215

interM

ELECTRICAL PARTS LIST (CA-6215)

Ref No.	Part No.	Description	Value	Qty
---------	----------	-------------	-------	-----

AMP B'D (4003487400B)

C1406 C1506	3698152198	CAP NPP POLY 152J 2J	152P	2
C1408 C1508	3678050177	CAP M1 DM10C 050D5	5PF/500V	2
C1507 C1407	3678220177	CAP M1 DM 10C 220J5	22PF/500	2
C1601	3549103107	CAP DE2F3KH103MA4B	0.01/500	1
C1705-1708 C1719-1722	3509103450-T	CAP CE 0.01UF 500V Z	0.01/500	8
C1711-1712 C1715-1716	3509103530-T	CAP CE F 0.01UF 50V Z	0.01/50	4
C1402 C1502	3688471118	CAP MO SR22C 471JA	471J	2
C1524-1525	3409222871-T	CAP AF RSG 0.22UF 50V 5 P	0.22/50	2
C1405 C1505	3409810141-T	CAP AF NP 100UF 25V	100/25 NP	2
C1718 C1726	3409210141-T	CAP AF RSG 100UF 25V 6 P	100/25	2
C1724	3409210181	CAP AF SG 100UF 63V	100/63	1
C1723	3409210208	CAP HM 1000UF 80V 20X25	1000/80	1
C1703-1704	3419510380	CAP AF HM 1000UF 63V 30P LUG	10000/63	2
C1713-1714 C1725 C1729	3409222171-T	CAP AF RSG 220UF 50V SG 10 P	220/50	4
C1709-1710	3419233261	CAP E RSG 3300UF 35V	3300/35	2
C1411-1412 C1511-1512	3409247991-T	CAP AF RSG 4.7UF 100V 5 P	4.7/100	4
C1401 C1501	3409547031-T	CAP AF 47UF 16V (MOSE)	47/16	2
C1727-1728	3408247131	CAP RSA 470UF 16V SNAP 10 P	470/16	2
C1730	3409247147-T	CAP SD 470UF 25V 10P	470/25	1
C1409-1410 C1509-1510	3609222120-T	CAP MA 0.0022UF 100V J	0.0022/100(M)	4
C1403-1404 C1413-1414 C1503-1504 C1513-1514	3609104120-T	CAP MA 0.1UF 100V J	0.1/100(M)	8
C1701-1702	3619334153	CAP POLY TM 0.33UF 250V	0.33/250	2
CN1701	4355923603	WAFER 7.62MM B 5	WAFER B5	1
CN1702	4428595009	CON WAFER A2505WV2-09P	WAFER/09P	1
CN801	4428595015	LW5267/LWB0640/2.5MM-15P	5267/15P	1
CN1501	4355923804	CONNECTOR WAFER 04P (J.ST)	WAFER 4P	1
CN2 CN1601-1602	4355923803	CONNECTOR WAFER 03P(J.ST)	WAFER/03P(JST)	3
CN1402 CN1502	4355923802	WAFER B-2P JST	WAFER/P02(JST)	2
CN3	4355923803	CONNECTOR WAFER 03P(J.ST)	WAFER/03P(JST)	1
CR1401 CR1501	3529103531-A	CAP CE F 10000PF 50V Z	10000P	2
D1702	2058100979	DIODE BRIDGE (KBP01G/KBP153G)	KBP 153G	1
D1701	2058100988	DIODE BRIDGE PBU 804	PBU 804	1
D1703-1708 D1711	2058100996	DIODE RECTIFIER LT1N4006(4007)	1N 4006	7
D1401-1409 D1501-1509 D1522-1523	2058304100	DIODE IN4148M	1N 4148	20
D1410-1411 D1510-1511	2058322100	DIODE 1SS145 ROHM	ISS 142	4
D1412-1413 D1512-1513	2058100110	DIODE RL207 PYUNG CHANG	RL207	4
D1709-1710	2058502240	DIODE ZENER UZ-24BM(1N5252B)	UZ 24BM	2
F1701-1702 F1801	4458999110	FUSE CLIP 5*20	2A	3
F1703	5508342625	FUSE PICOR251002 2A/125V U/C/J	2A/125V	1
G101 G1401 G1501	4235007210	GND TERMINAL (POWER B'D)		3

IC1701	2128610900	IC KA7815 COMMON	7815	1
IC1702	2128610800	IC MC7915 COMMON	7915	1
IC1703	2128611206	IC 7805 G.S	7805	1
IC1704	2118050410	IC TA7317P TOSHIBA	TA 7317P	1
JK1401-1402 JK1501-1503	4438192210	PHONEL JACK (5P) MOLD	JACK(5P)	5
L1401 L1501	2648099940	COIL INDUCTOR 1.2UH	1.2uH	2
P1401 P1501	2438007994	POSISTOR PTFLO4BE471Q2N34B0	BE471TS	2
P1402 P1502	2438007993	POSISTOR PTFM04BE222Q2N34B0	BE222TS	2
Q1407 Q1410 Q1507 Q1510	2028407990	KTC4370A-Y-U	KTC4370A	4
Q1701	2028407118	KTC2238A-Y-U	KTC2238	1
Q1412 Q1414 Q1512 Q1514	2028427998	TR 2SC 3856 W/ACC	2SC3856	4
Q1406 Q1506	2008606107-T	KTC3206-Y-AT	KTC 3206Y	2
Q1404 Q1408 Q1504 Q1508 Q1534 Q1536-1537 Q1539	2008606108-T	KTC3200-BL-AT	KTC 3200BL	8
Q1413 Q1415 Q1513 Q1515	2028117994	TR PNP 2SA 1492 W/ACC	2SA 1492	4
Q1411 Q1511	2028107984	KTA1659A-Y-U	KTA 1659A	2
Q1535 Q1538	2008206104-T	KTA1268-BL-AT	KTA 1268BL	2
Q1401-1403 Q1409 Q1501-1503 Q1509	2008206106-T	KTA2400-GR-AT	KTA 2400G	8
Q1405 Q1505	2008206997-T	KTA1024-Y-AT	KTA 1024Y	2
R1436-1437 R1442-1443 R1536-1537 R1542-1543	3049478783	RES CE 0.47 5W J T HAN NAE	0.47 5W	8
R1415 R1515	3009000973	RES CF 0 1/5W JN	0 1/5W	2
R1405 R1505	3009122973	RES CF 1.2K 1/5W J N	1.2K	2
R1418 R1518	3009182973	RES CF 1.8K 1/5W J N	1.8K	2
R1434-1435 R1440-1441 R1534-1535 R1540-1541	3089101275	RES NFR 100 1/4W J R PHILKO	FR 100	8
R1705	3009104973	RES CF 100K 1/5W J N	100K	1
R1413 R1513	3009100973	RES CF 10 1/5W J N	10	2
R1420-1421 R1520-1521	3089100275	RES NFR 10 1/4W J R PHILKO	FR 10	4
R1445 R1545	3059100772	RES CE 10 5W JN	10 5W	2
R1414 R1514	3002100953	RES CF 10K 1/5W F N	10K 1%	2
R1406 R1506	3009121973	RES CF 120 1/5W J N	120	2
R1404 R1504	3009123973	RES CF 12K 1/5W J N	12K	2
R1448 R1450 R1548 R1550	3009184973	RES CF 180K 1/5W J N	180K	4
R1409 R1509	3009102973	RES CF 1K 1/5W J N	1K	2
R1557 R1563	3009221973	RES CF 220 1/5W J N	220	2
R1422-1423 R1428-1431 R1522-1523 R1528-1531	3089221275	RES NFR 220 1/4W J R PHILKO	FR 220	12
R1555 R1560	3009224973	RES CF 220K 1/5W J N	220K	2
R1709	3059220784	RES CE 22 5W K T	22 5W	1
R1446-1447 R1546-1547 R1556 R1558-1559	3009223973	RES CF 22K 1/5W J N	22K	14

R1561-1562 R1564 R1567-1568 R1706-1707				
R1401 R1501	3009271973	RES CF 270 1/5W J N	270	2
R1702	3009332973	RES CF 3.3K 1/5W J N	3.3K	1
R1424-1425 R1524-1525	3089332275	RES NFR 3.3K 1/4W J R PHILKO	FR 3.3K	4
R1449 R1549	3009334973	RES CF 330K 1/5W J N	330K	2
R1432-1433 R1438-1439 R1532-1533 R1538-1539	3089479275	RES NFR 4.7 1/4W J R PHILKO	FR 4.7	8
R1444 R1544	3039479575-T	RES MO 4.7 2W J RADIAL	4.7 2W	2
R1419 R1519 R1703	3009471973	RES CF 470 1/5W J N	470	3
R1402 R1410-1412 R1502 R1510-1512	3009473973	RES CF 47K 1/5W J N	47K	8
R1403 R1407-1408 R1503 R1507-1508	3009561973	RES CF 560 1/5W J N	560	6
R1426-1427 R1526-1527	3009563973	RES CF 56K 1/5W J N	56K	4
R1565-1566	3009622973	RES CF 6.2K 1/5W J N	6.2K	2
R1708	3009682973	RES CF 6.8K 1/5W J N	6.8K	1
R1704	3009822973	RES CF 8.2K 1/5W J N	8.2K	1
R1416-1417 R1516-1517	3089820275	RES NFR 82 1/4W J R PHILKO	FR 82	4
RY1401 RY1501	5528009992	RELAY HR-702NH DC24V(18V)	HR703H DC24V	2
SW1601	4648098310	SW POWER PUSH JPP 1197CAS34	SW POWER	1
TP1401-1402 TP1501-1502	4678699411	CNT PLUG 1P		4
VR1401 VR1501	3688471118	CAP MO SR22C 471JA	470B	2

PCB MAIN B'D (4003487500A)

C1102	3509562530-T	CAP CE F 0.0056UF 50V Z	0.0056/50	1
C1126-1127	3509103530-T	CAP CE F 0.01UF 50V Z	0.01/50	2
C1129	3539104531-A	CAP CE Y 100000PF 50V Z AXIAL	100000P	1
C1-14 C121 C221 C321 C421 C521 C621 C1005 C1132 C1135-1136	3529103531-A	CAP CE F 10000PF 50V Z	10000P	24
C110-111 C210-211 C310-311 C410-411 C510-511 C610-611 C730 C739-740 C814 C901-902 C906 C1008	3509101231-A	CAP CE B 100PF 50V K AXIAL	100P	20
C119 C219 C319 C419 C519 C619 C904 C1003	3529100311-A	CAP CE SL 10PF 50V J AXIAL	10P	8
C702 C802	3509221231-A	CAP CE B 220PF 50V K AXIAL	220P	2
C1121-1122	3529270311-A	CAP CE SL 27PF 50V J AXIAL	27P	2
C707 C807	3509331231-A	CAP CE B 330PF 50V K AXIAL	330P	2
C1006	3529330311-A	CAP CE SL 33PF 50V J AXIAL	33P	1
C105-108 C205-208 C305-308 C405-408 C505-508 C605-608 C712 C812	3509471231-A	CAP CE B 470PF 50V K AXIAL	470P	26
C708 C742 C808	3529470311-A	CAP CE SL 47PF 50V J AXIAL	47P	3
C1103	3509561130-T	CAP CE B 560PF 50V J	560P	1
C1125 C1128	3509561231-A	CAP CE B 560PF 50V K AXIAL	560P	2

C703 C803	3529680311-A	CAP CE SL 68PF 50V J AXIAL	68P	2
C727 C828	3509821130-T	CAP CE B 820PF 50V K	820P	2
C715 C815	3409210971-T	CAP AF RSG 1UF 50V 5 P	1/50	2
C1123 C1130	3409210973-T	CAP E SE 1UF 50V 3*5	1/50(SE)	2
C1101	3409210072-T	CAP AF SE 10UF 50V 6.3X5(2.5MM)	10/50(SE)	1
C701 C801 C1016 C1001	3409210142-T	CAP AF SE 100UF 25V 8X5(2.5MM)	100/25(SE)	4
C713 C813 C1007 C736	3409210141-T	CAP AF RSG 100UF 25V 6 P	100/25	4
C103-104 C203-204 C303-304 C403-404 C503-504 C603-604	3409222071-T	CAP AF RSG 22UF 50V 5 P	22/50	12
C320 C120 C513 C520 C220 C420 C613 C620 C705 C711 C741 C743 C805 C811 C903 C905 C1004 C113 C213 C313 C413 C704 C804	3409247042-T	CAP AF SE 47UF 25V 8X5 (2.5MM)	47/25	23
C101-102 C201-202 C301-302 C401-402 C501-502 C601-602	3409222081-T	CAP AF RSG 22UF 63V 6 P	22/63	12
C731-733 C830-832	3409247972-T	CAP AF RSS 4.7UF 50V 5 P	4.7/50	6
C1015 C1139	3409247033-T	CAP E SE 47UF 16V 6.3*5	47/16	2
C123 C223 C323 C423 C523 C623	3409247081-T	CAP AF SG 47UF 63V 8 P	47/63	6
C109 C209 C309 C409 C509 C609	3409247121-T	CAP AF RSG 470UF 10V SG 8 P	470/10	6
C714 C718 C816 C819	3639184111-T	CAP ECQ-V 1H184JL2 0.18UF 50V	0.18/50	4
C1108-1109 C1114-1115 C1118 C1120	3639334111-T	CAP ECQ-V 1H334JL2 0.33UF 50V	0.33/50	6
C716 C817	3639394111-T	CAP ECQ-V 1H394JL2 0.39UF 50V	0.39/50	2
C114 C214 C314 C414 C514 C614	3609152120-T	CAP MA 0.0015UF 100V J	0.0015/100(M)	6
C725 C826	3609182120-T	CAP MA 0.0018UF 100V J	0.0018/100(M)	2
C115 C215 C315 C415 C515 C615	3609222120-T	CAP MA 0.0022UF 100V J	0.0022/100(M)	6
C116 C216 C316 C416 C516 C616	3609392120-T	CAP MA 0.0039UF 100V J	0.0039/100(M)	6
C723 C726 C824 C827	3609472120-T	CAP MA 0.0047UF 100V J	0.0047/100(M)	4
C724 C825 C1111-1113 C1116-1117 C1119	3609103120-T	CAP MA 0.01UF 100V	0.01/100(M)	8
C721 C822	3609123120-T	CAP MA 0.012UF 100V J	0.012/100(M)	2
C719 C722 C820 C823	3609273120-T	CAP MA 0.027UF 100V J	0.027/100(M)	4
C117-118 C217-218 C317-318 C417-418 C517-518 C617-618 C1105-1107 C1124	3609473120-T	CAP MA 0.047UF 100V	0.047/100(M)	16
C717 C720 C818 C821	3609683120-T	CAP MA 0.068UF 100V J	0.068/100(M)	4
CN801	4428594915	LA5268/LAB0640/2.5MM-15P	5268/15P	1
D101-104 D201-204 D301-304 D401-404 D501-504 D601-604	2058304100	DIODE IN4148M	1N 4148	24
F1101	3908609980	EMI FILTER 2200PF	2200P	1
IC1101	2128130500	IC M65841SP MITSUBISHI	M65841SP	1

IC712-713 IC801-802	2118030405	KIA6966S	6966	4
IC714	2118010432	IC NJM2068DD JRC	NJM 2068DD	1
IC101-102 IC301-302 IC501-502 IC701-702 IC1001	2168220989	IC NJM 2068L JRC	NJM 2068L	9
IC704-710	2118010590	IC NJM4558D JRC	NJM 4558D	7
IC1102-1103	2168220991	IC NJM 4558L JRC	NJM 4558L	2
IC711 IC901	2118220988	IC NJM 4580D	NJM 4580D	2
JK102 JK202 JK204 JK302 JK402 JK502 JK602 JK701 JK801 JK902 JK1001	4438192910	PHONE JACK (5P) METAL	PHONE5P	11
JK702 JK901	4438194610	RCA JACK BOARD 4P(24MM)	RCA	2
JK101 JK201 JK301 JK401 JK501 JK601	4438193810	XLR JACK(F) 3P(E203A0040N)	XLR(FM)	6
L701-704 L801-804 L809	2300032100 8545993360	LED LTL-1CHG LITEON LED LIMITER	GRE	9
L705-707 L805-807	2300033100 8545993360	LED LTL-1CHA LITEON LED LIMITER	YEL	6
L708 L808 L810 L1101	2300030100 8545993360	LED LTL-1CHE LITEON LED LIMITER	RED	4
Q1101-1102	2008206104-T	KTA1268-BL-AT	KTA 1268BL	2
Q101-102 Q201-202 Q301-302 Q401-402 Q501-502 Q601-602	2008206106-T	KTA2400-GR-AT	KTA 2400G	12
R737-738	3009122973	RES CF 1.2K 1/5W J N	1.2K	2
R735-736 R840	3009152973	RES CF 1.5K 1/5W J N	1.5K	3
R114 R214 R314 R414 R514 R614	3009182973	RES CF 1.8K 1/5W J N	1.8K	6
R908	3009101973	RES CF 100 1/5W J N	100	1
R132 R232 R332 R432 R532 R632 R832	3089101275	RES NFR 100 1/4W J R PHILKO	FR 100	7
R65 R90 R105-106 R133 R205-206 R231 R305-306 R331 R405-406 R431 R505-506 R605-606 R704 R725 R804 R846	3009104973	RES CF 100K 1/5W J N	100K	22
R108-109 R208-209 R308-309 R408-409 R508-509 R608-609	3009100973	RES CF 10 1/5W J N	10	12
R122 R124 R222 R224 R322 R324 R422 R424 R522 R524 R622 R624 R751-752 R1003 R1103 R1131 R1134 R1136 R1138-1139 R1142-1143 R1166-1167	3009103973	RES CF 10K 1/5W J N	10K	25
R837	3039103472-F	RES MO 10K 1W	10K 1W	1
R1164	3009113973	RES CF 11K 1/5W J N	11K	1
R906	3009124973	RES CF 120K 1/5W J N	120K	1
R120 R220 R320 R420 R520 R620	3009123973	RES CF 12K 1/5W J N	12K	6
R1165	3009133973	RES CF 13K 1/5W J N	13K	1
R1101	3009154973	RES CF 150K 1/5W J N	150K	1
R1102 R1126-1129	3009153973	RES CF 15K 1/5W J N	15K	5

R126-128 R226-228 R326-328 R426-428 R526-528 R626-628 R905 R910 R1006	3009183973	RES CF 18K 1/5W J N	18K	21
R739-741 R747-750 R826-828 R841-844	3009102973	RES CF 1K 1/5W J N	1K	14
R1121	3009105973	RES CF 1M 1/5W J N	1M	1
R111 R113 R211 R213 R311 R313 R411 R413 R511 R513 R611 R613 R705 R805 R901-902	3009222973	RES CF 2.2K 1/5W J N	2.2K	16
R707-708 R807-808 R1132-1133	3009272973	RES CF 2.7K 1/5W J N	2.7K	6
R743 R830 R1130	3009203973	RES CF 20K 1/5W J N	20K	3
R703 R803 R1002	3009221973	RES CF 220 1/5W J N	220	3
R115 R215 R315 R415 R515 R615	3009220973	RES CF 22 1/5W J N	22	6
R103-104 R203-204 R303-304 R403-404 R503-504 R603-604	3009392973	RES CF 3.9K 1/5W J N	3.9K	12
R121 R221 R321 R421 R521 R621 R742 R829	3009303973	RES CF 30K 1/5W J N	30K	8
R1108	3009330973	RES CF 33 1/5W J N	33	1
R254 R270 R701 R801 R907	3009363973	RES CF 36K 1/5W J N	36K	5
R1124 R1163	3009302973	RES CF 3K 1/5W J N	3K	2
R107 R118 R207 R218 R307 R318 R407 R418 R507 R518 R607 R618 R706 R806 R1007 R1105-1107 R1125	3009472973	RES CF 4.7K 1/5W J N	4.7K	19
R1140	3009471973	RES CF 470 1/5W J N	470	1
R101-102 R201-202 R301-302 R401-402 R501-502 R601-602 R710 R809 R903-904 R909 R1004 R1104 R1135	3009473973	RES CF 47K 1/5W J N	47K	20
R711 R713 R715 R717 R719 R721 R723 R812 R814 R816 R818 R821-822 R825	3009561973	RES CF 560 1/5W J N	560	14
R119 R219 R319 R419 R519 R619 R712 R714 R716 R718 R720 R722 R724 R813 R815 R817 R819-820 R823-824	3009563973	RES CF 56K 1/5W J N	56K	20
R129-130 R229-230 R329-330 R429-430 R529-530 R629-630	3003680953	RES CF 6.8K 1/5W F N	6.8K 1%	12
R110 R112 R210 R212 R310 R312 R410 R412 R510 R512 R610 R612	3009682973	RES CF 6.8K 1/5W J N	6.8K	12
R838-839	3039681472-F	RES MO 680 1W J	680 1W	2
R745 R833	3009683973	RES CF 68K 1/5W J N	68K	2
R1109 R1111 R1113 R1115 R1118-1119	3009752973	RES CF 7.5K 1/5W J N	7.5K	6

R709 R810 R1005	3009750973	RES CF 75 1/5W JN	75	3
R1001 R1110 R1112 R1114 R1116-1117 R1120	3009753973	RES CF 75K 1/5W J N	75K	7
R123 R223 R323 R423 R523 R623	3009822973	RES CF 8.2K 1/5W J N	8.2K	6
R744 R746 R831 R834	3009823973	RES CF 82K 1/5W J N	82K	4
R116-117 R216-217 R316-317 R416-417 R516-517 R616-617	3003909953	RES CF 9.09K 1/5W F N	9.09K 1%	12
SW101 SW201 SW301 SW401 SW501 SW601 SW801	4628991310	SW PUSH SPEA122SCO11(SUD40)	SW6P/SUD40	7
SW1101-1104	4628980710	SW PUSH SPEA412HC011	SPEA412	4
SW701	4618999910	SW SS65010-0203-9H-FN	SLIDE/SS65010	1
VR101-103 VR201-203 VR301-303 VR401-403 VR501-503 VR601-603	3228070020	VR RK09K11S000553B (50KB)	50KB	18
VR104-106 VR204-206 VR305-307 VR405-407 VR504-506 VR604-606 VR701 VR801 VR901-902 VR1001 VR1101-1102	3228070030	VR RK09K11N000523A	20KA	25
VR708 VR702 VR802-808 VR703-707	3238080610	VR RS20H113D12B23W C.C	20KW	14
X1101	3908101982	CRYSTAL 4.000MHZ 49/S 20PF	4MHz	1

ASS'Y

AC CORD	4448996710	AC INLET (6200,2300) SYS-6004	AC CORD	1
	4308999710	CORD AC DOME 3 CORES		1
	4308994910	4308994910	B , R	1
	4308991210	AC CORD EL-210/ENDCUT(UK)	C	1
	4308999210	AC UP502+OCSA0.75MM2X3C200MM	D	1
	4308999910	CORD AC UL 3CORES	E	1
FUSE	5508213239	FUSE#217F 20MM 4A/250V UCSKJ		3
	5508212739	FUSE#217F 20MM 2A/250V UCSKJ		2
	5508412729	FUSE#218T 20MM 2A/250V UCSKJ	B , C , D , E , R	8
	5508413239	FUSE#218T 20MM 4A/250V UCSKJ	B , C , D	3
	5508213739	FUSE#234F 20MM 8A/250V UCKJ	E	1
CON	4355779519	CON ASS'Y 4P JST 3.96		1
	4355773200	CON ASS'Y 3P 3.96 (220V)		1
	4355779624	CON ASS'Y 15P RLAT		1
	4448200210	CLLOSE & CONNECTOR CEC2SQ		2
	4355773100	CON ASS'Y 3P 3.96 (230V)	B , C , D , R	2
PT	2828065911	TRANS POWER 220V CA-6215		1
	2828065921	TRANS POWER 230V CA-6215	B , C , R	3
	2828065931	TRANS POWER 240V CA-6215	D	1
	2828065901	TRANS POWER 120V CA-6215	E	1

AMP B'D 4003487400B

*** NOTE ***

- 1) PART OF POWER
- IC KA7815 : IC1701
 - IC KA7915 : IC1702
 - IC KA7805 : IC1703
 - IC TA7317P : IC1704
 - TR NPN KTC2240BL : Q101,Q103
 - TR NPN 2SC3298A(KTC4370A) : Q102,Q104,Q105,Q106
 - DIODE BRIDGE KBU804(PBU804) : D1701
 - DIODE LT1N4006 : D1703,D1704,D1705,D1706,D1707,D1708
 - DIODE ZENER 24BM : D1709,D1710
 - DIODE BRIDGE KBP 01: D1702
- 2) PART OF AMP
- TR PNP KTA2400 : Q1401-Q1403,Q1409,Q1501-Q1503,Q1509
 - TR NPN KTC2240BL(KTC3200BL) : Q1404,Q1408,Q1504,Q1508
 - TR PNP KTA949Y/A1024 : Q1405,Q1505
 - TR NPN KTC2229/C3206 : Q1406,Q1506
 - TR NPN 2SA1306A(KTA1659A) : Q1411,Q1511
 - TR NPN 2SC3298A(KTC4370A) : Q1407,Q1410,Q1507,Q1510
 - TR NPN A1695 : Q1413,Q1415,Q1513,Q1515
 - TR NPN C4468 : Q1412,Q1414,Q1512,Q1514
 - DIODE PS2010 : D1412,D1413,D1512,D1513
 - DIODE IN4148 : D1403-D1411,D1503-D1511
 - POSISTOR BE471TS : P1401,P1501
 - POSISTOR BE222TS : P1402,P1502

SERVICE INFORMATION

1.RESISTANCE VALUES ARE INDICATED IN OHMS UNLESS OTHERWISE SPECIFIED.
(K=1,000, M=1,000,000)

2.CAPACITANCE VALUES ARE SHOWN IN MICROFARADS UNLESS OTHERWISE NOTED.
(P=PICO-MICROFARADS)

3.ALL VOLTAGES ARE REFERED TO GROUND UNDER THE FOLLOWING CONDITIONS.
DC:NO SIGNAL EXCEPT WHERE INDICATED.
AC:RMS

4.-PRECAUTION-

A) ALL COMPONENTS MARKED MUST BE REPLACED ONLY WITH ORIGINAL TYPE SPECIFIED BY THE MANUFACTURER. INTER M CORPORATION AND INSTALLED AS THE ORIGINAL SPACERS AND POSITIONED AWAY FROM ADJACENT COMPONENTS WHERE APPLICABLE.

B) ALL SOLDERING MUST BE DONE IN A PROFESSIONAL MANNER USING SOLDER WHITE RESINE CORE ONLY.

C) ALL COVERS, SHIELD AND INSULATING SPACERS MUST BE REPLACED BEFORE RETURNING APPLIANCE TO CUSTOMER.

D) A DAMAGE POWER SUPPLY CORD MUST BE REPLACED BEFORE RETURNING TO CUSTOMER.

E) DIELECTRIC TEST CONSISTING OF 120V AC 60HZ IS TO BE APPLIED BETWEEN BOTH BALDES OF THE POWER SUPPLY CORD ATTACHMENT PLUG THE EXPOSE CONDUCTIVE SURFACE OF THE APPLIANCE FOR A PERIOD OF NOT LESS THAN ONE SECOND BEFORE RETURNING APPLIANCE TO CUSTOMER.

F) THE "M" MARKED RESISTORS ARE MOUNTED THE P.C.B ON SLEEVES.

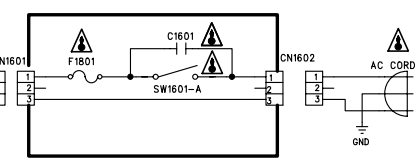
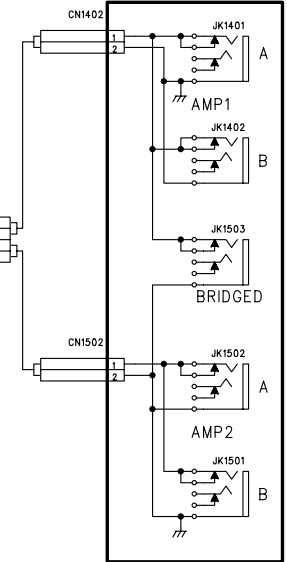
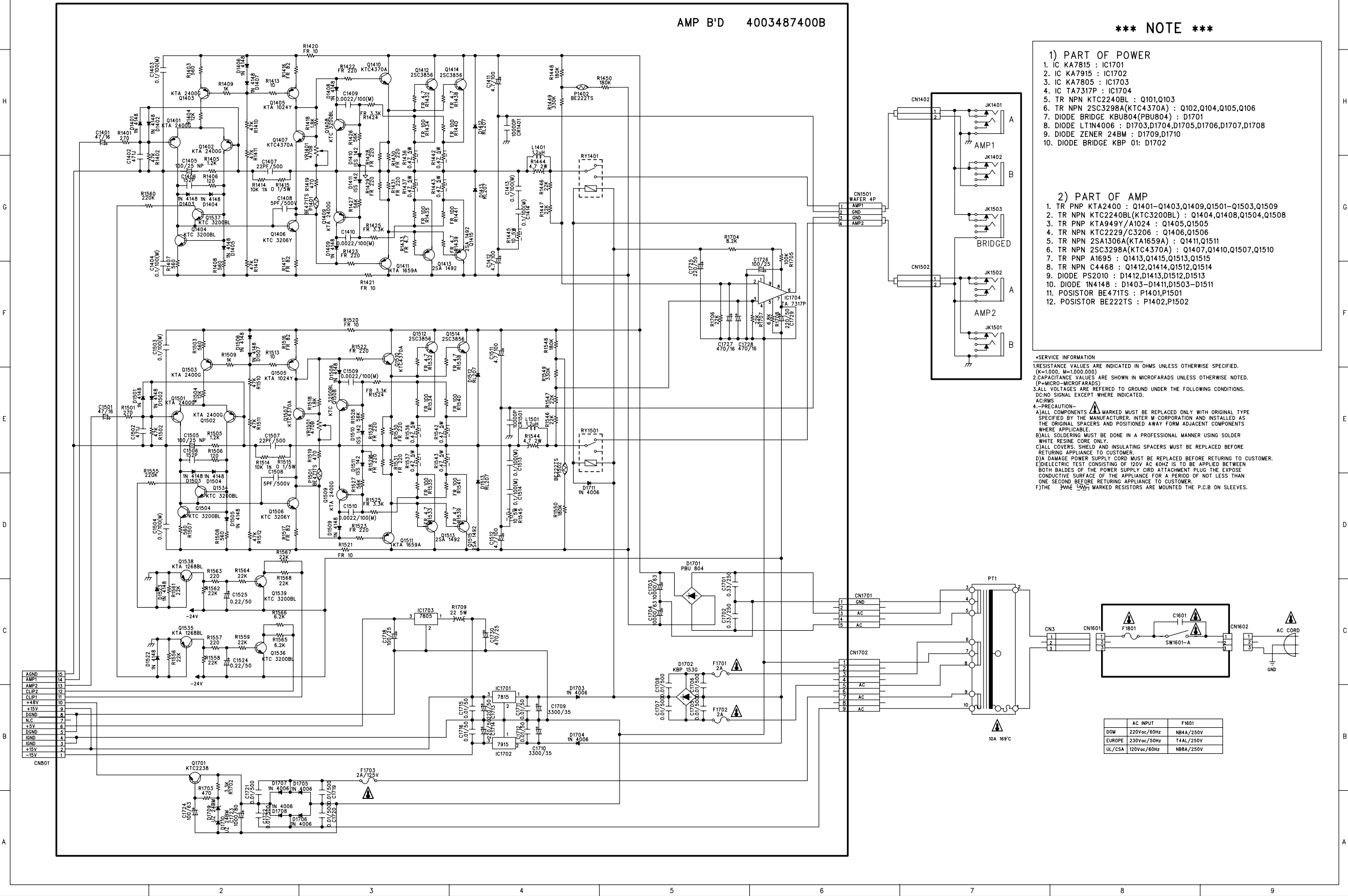

	AC INPUT	F1601
DOM	220Vac/60Hz	NB4A/250V
EUROPE	230Vac/50Hz	T44L/250V
UL/CSA	120Vac/60Hz	NB8A/250V

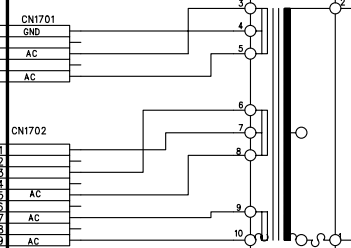
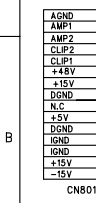

COMPANY	INTER.M	APPLICANT	REVISED NUMBER AND DATE						DRAWN	CHECKED	APPROVED	NOTE	SHEET NO.	SCHEMATIC DIAGRAM
TYPE CODE	990805	MP	1.	4.	7.	2.	5.	8.	3.				1/2	MODEL :
APPROVED DATE	990805		3.	6.	9.	4.								CA-6215

MIXER B'D-CH1,2

40034487500
REC OUT

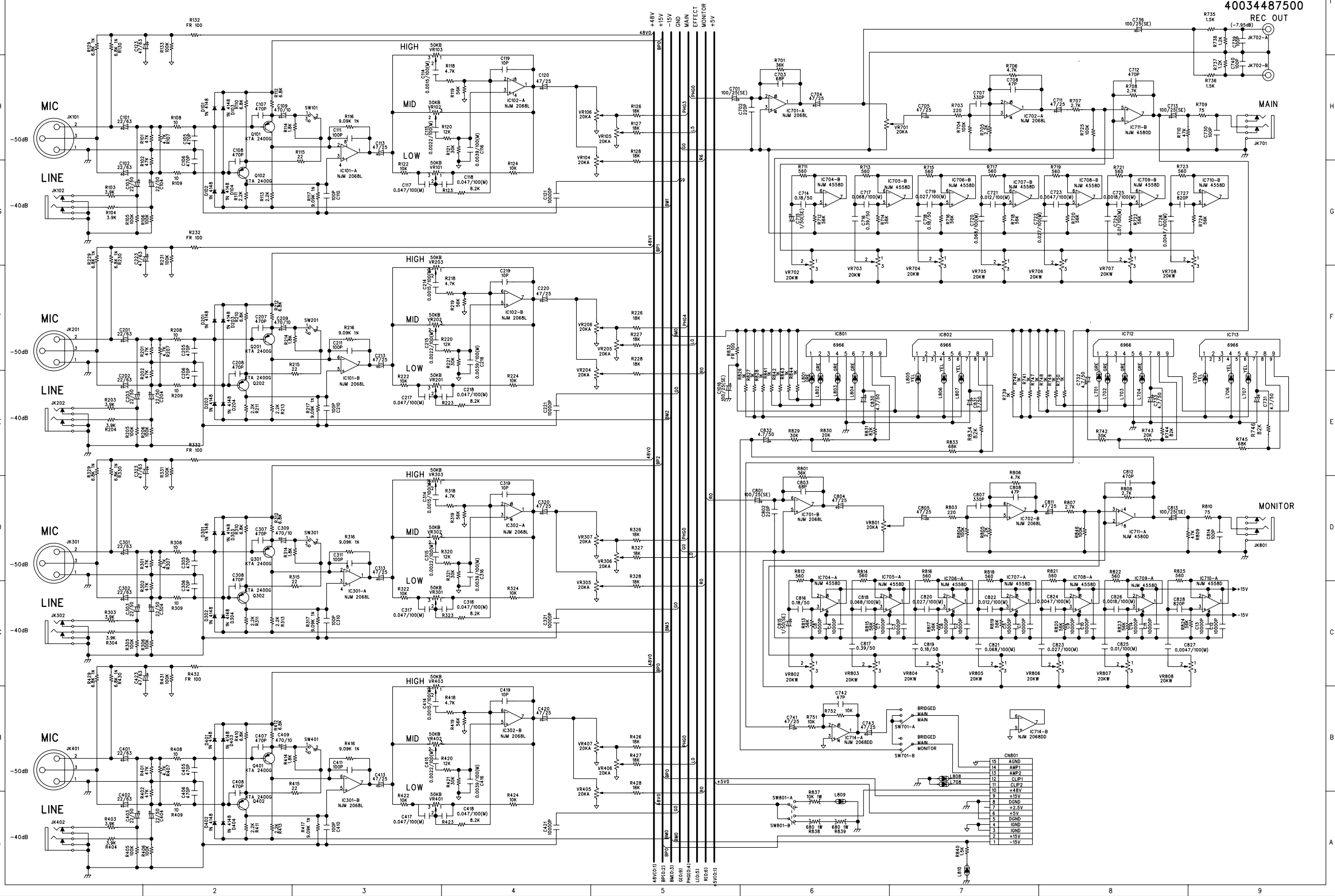

1	2	3	4	5	6	7	8	9
---	---	---	---	---	---	---	---	---

