

John Bowers active 1

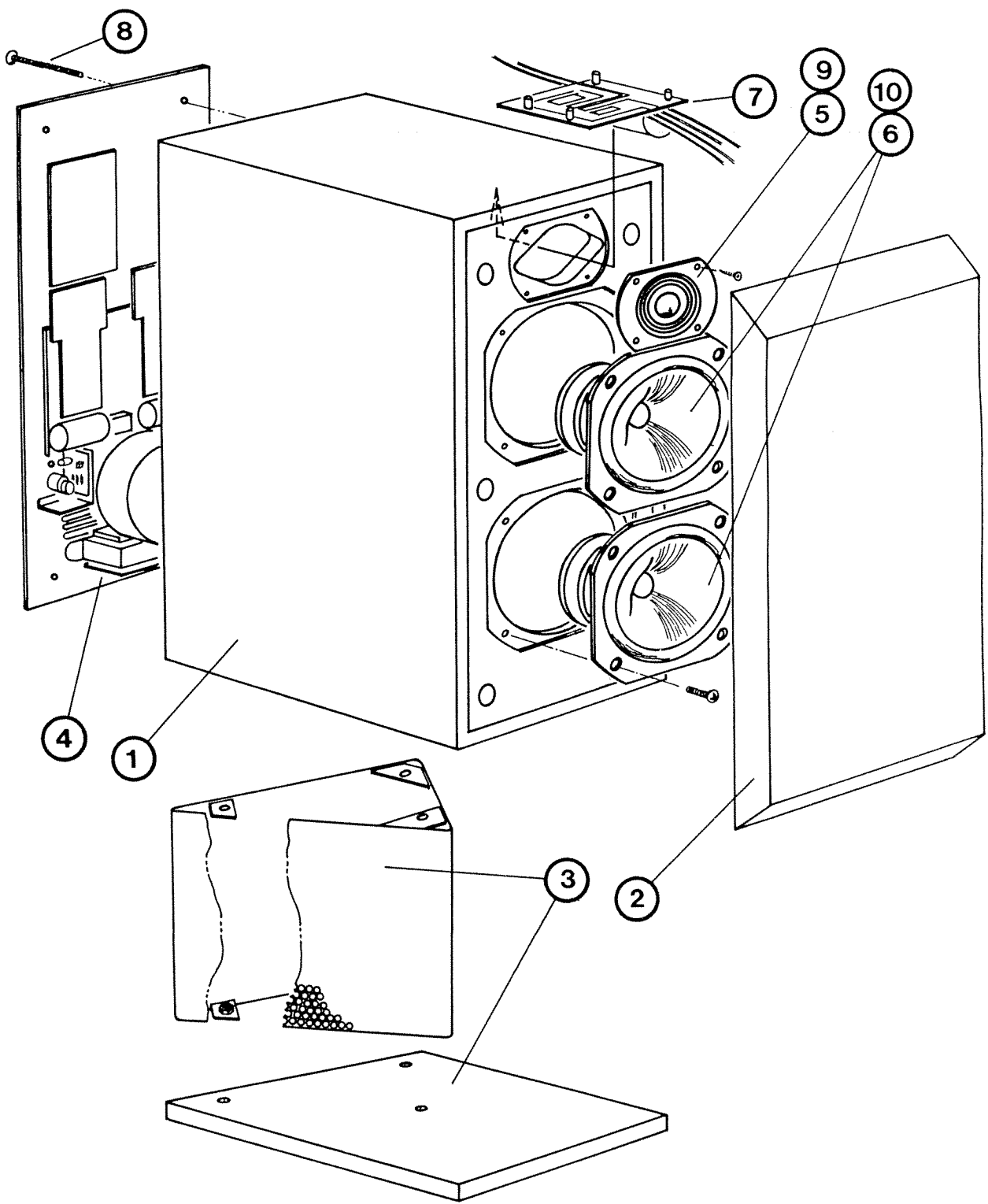

Active 1 Service and Parts Manual

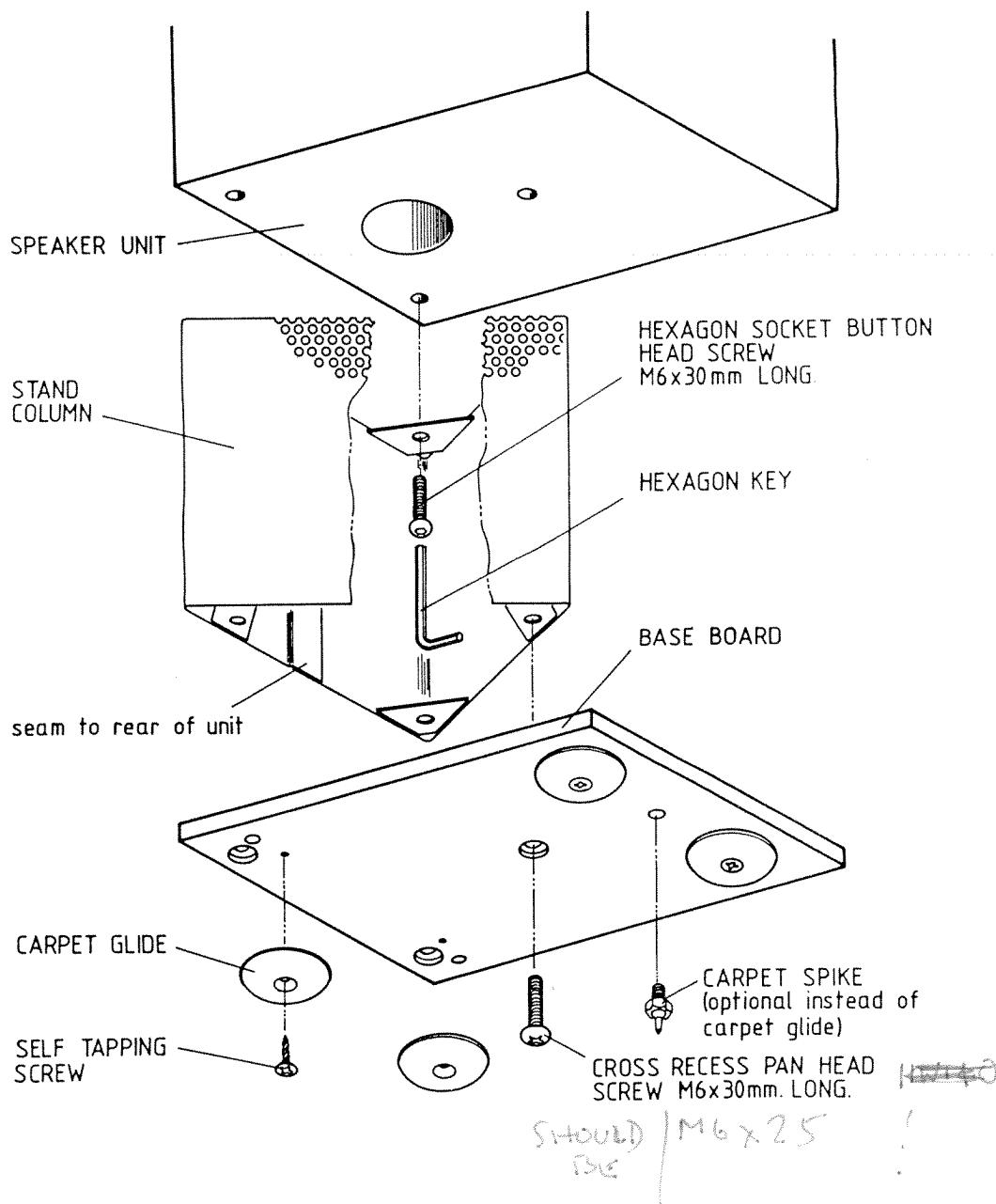

ITEM	QTY.	CODE No.	DESCRIPTION
1	1		CABINET ASSEMBLY
2	1		GRILLE ASSEMBLY
3	1		STAND ASSEMBLY
4	1		BACK PLATE ASSEMBLY
5	1		H.F. DRIVER <i>FIXING SCREW HF = M4 x 25 POZI CSK</i>
6	2		MID L.F. AND L.F. DRIVER <i>FIXING SCREW BASS = M6 x 25 POZI/PAN</i>
7	1		PASSIVE CROSSOVER ASSEMBLY
8	8		BACK PLATE RETAINING SCREW
9	4		H.F. DRIVER RETAINING SCREW
10	8		MID L.F. AND L.F. DRIVER RETAINING SCREW



ASSEMBLY OF STAND COLUMN AND BASE BOARD TO SPEAKER UNIT

- (1) With Speaker Unit laying on one side on a non-scratching surface, assemble Stand Column (with seam to rear of unit) to Speaker Cabinet, using 3 Hexagon Socket Button Head Screws. Tighten using Hexagon Key provided.
- (2) Assemble Base Board to underside of Stand Column using 3 Cross Recess Pan Head Screws.
- (3) Assemble Carpet Glides using Self-Tapping Screws.

OPTIONAL CARPET SPIKES INSTEAD OF CARPET GLIDES

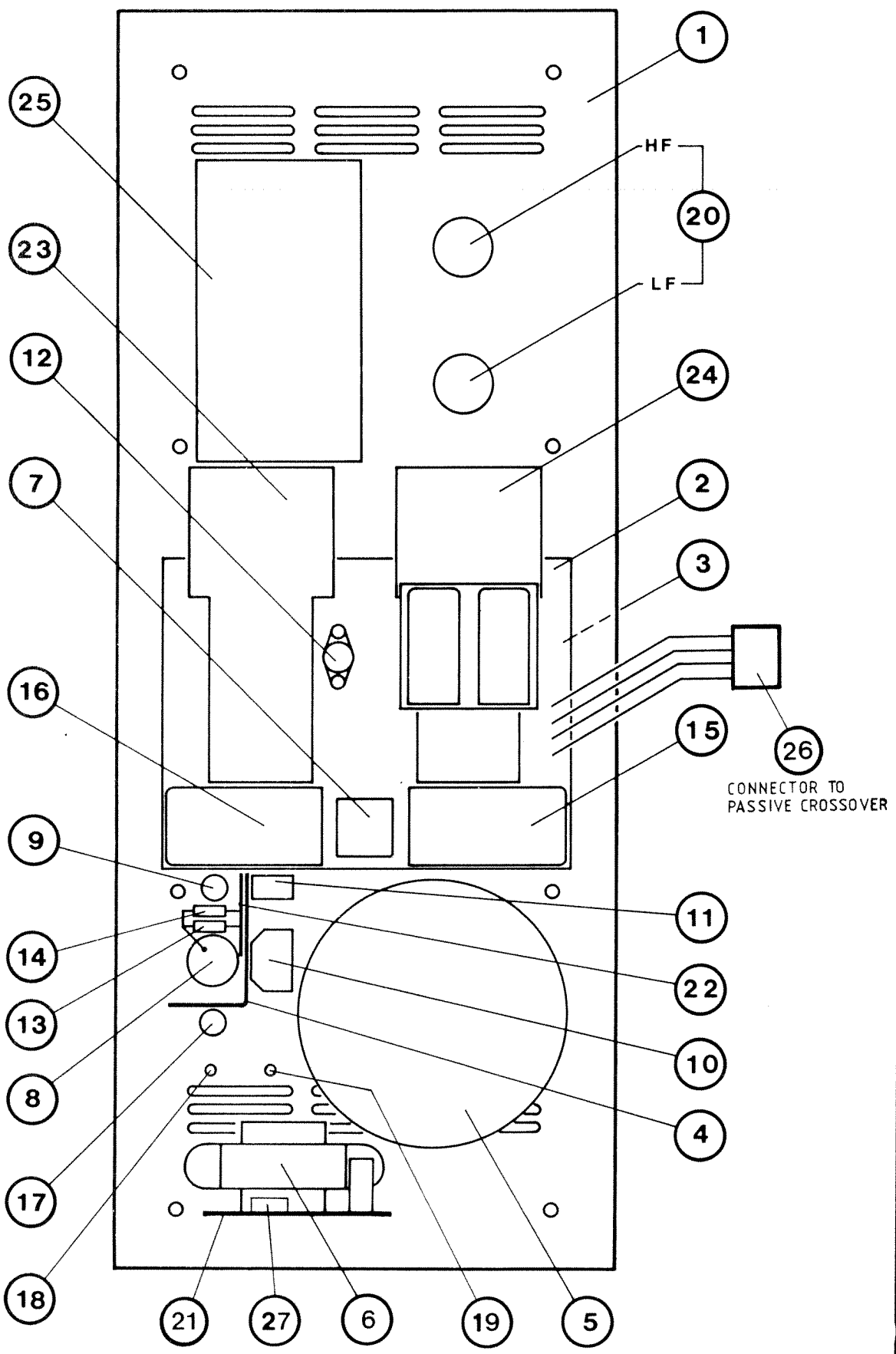

20

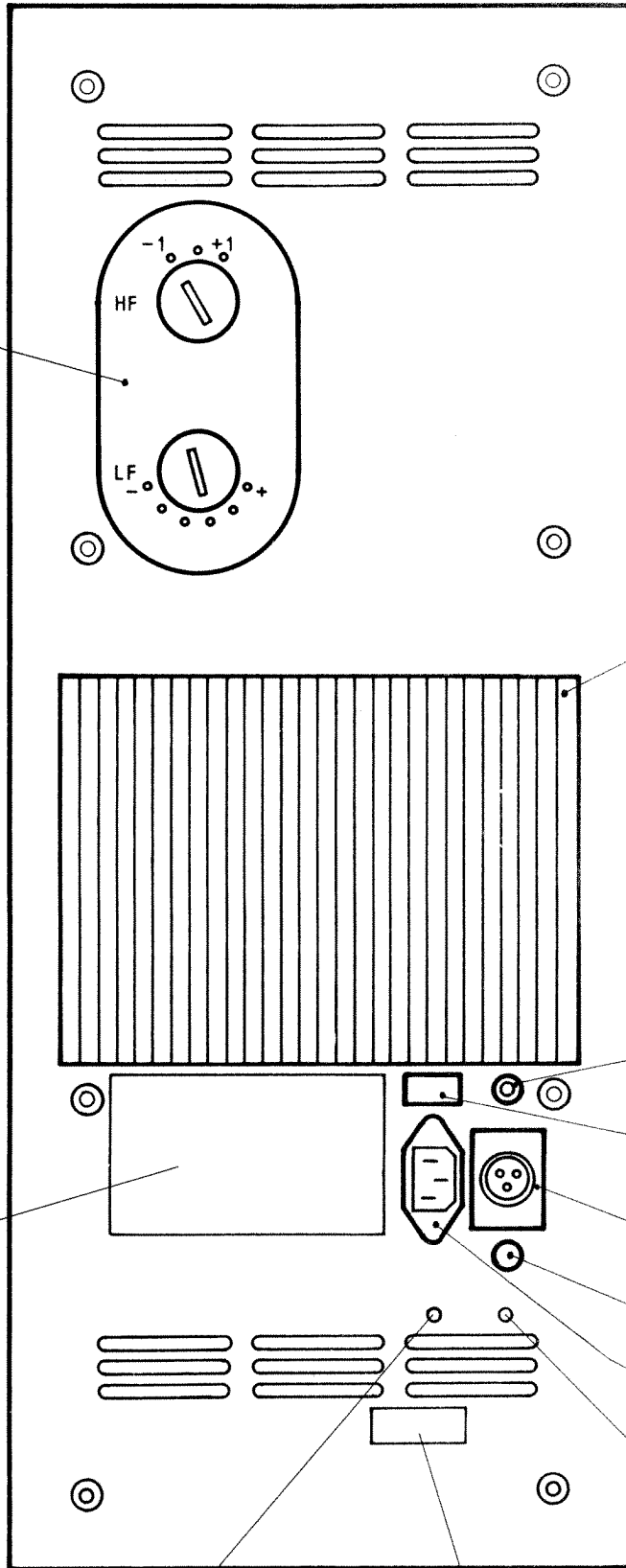

3

9

11

8

17

10

18

RED

SUPPLY VOLTAGE AND FUSE RATING LABEL

19 GREEN

SERIAL NUMBER

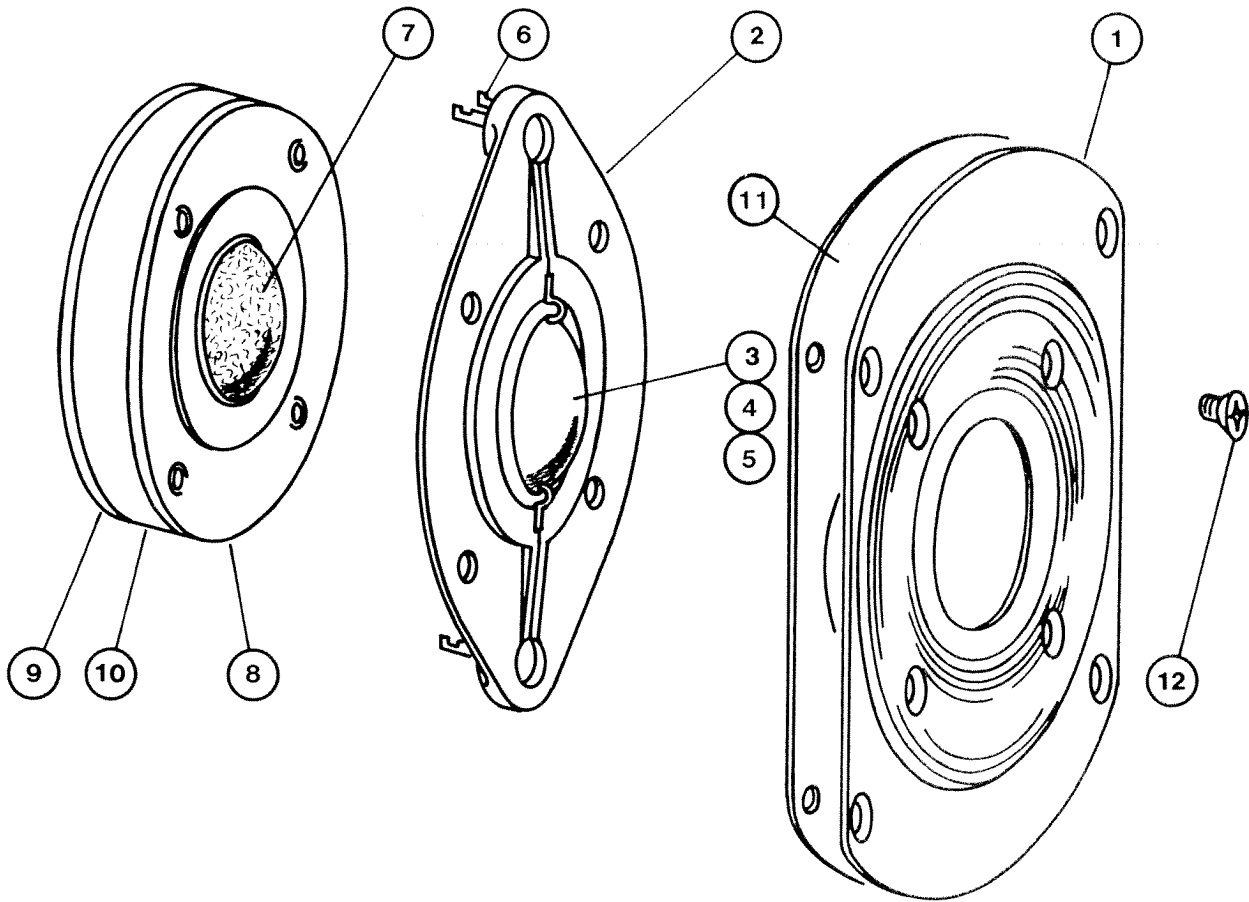

ITEM	QTY.	CODE No.	DESCRIPTION
-	-	22804A	HIGH FREQUENCY UNIT - COMPLETE ASSEMBLY. FFT
1	1		FRONT PLATE.
2	1		MOUNTING PLATE FOR DIAPHRAGM AND COIL.
3	1		DIAPHRAGM.
4	1		COIL AND COIL FORMER COMPLETE.
5	-		SLEEVING.
6	2		BRASS TAG.
7	1		FELTED DOME.
8	1		TOP PLATE.
9	1		BACK PLATE AND POLE PIECE ASSEMBLY.
10	1		MAGNET.
11	1		GASKET.
12	4		COUNTERSUNK HEAD SCREW.

NOTE 1ST TYPE TWEETERS WERE NOT FFT (I.E. FERROFLUX)
 2ND TYPE " " " FFT

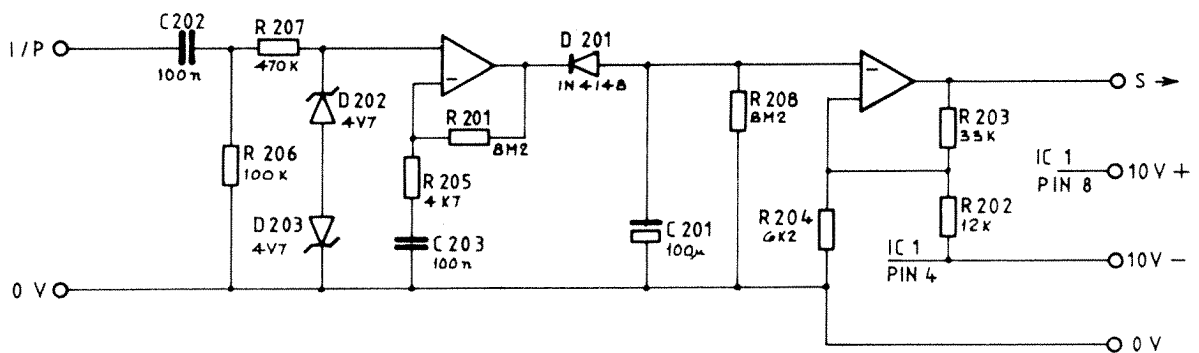
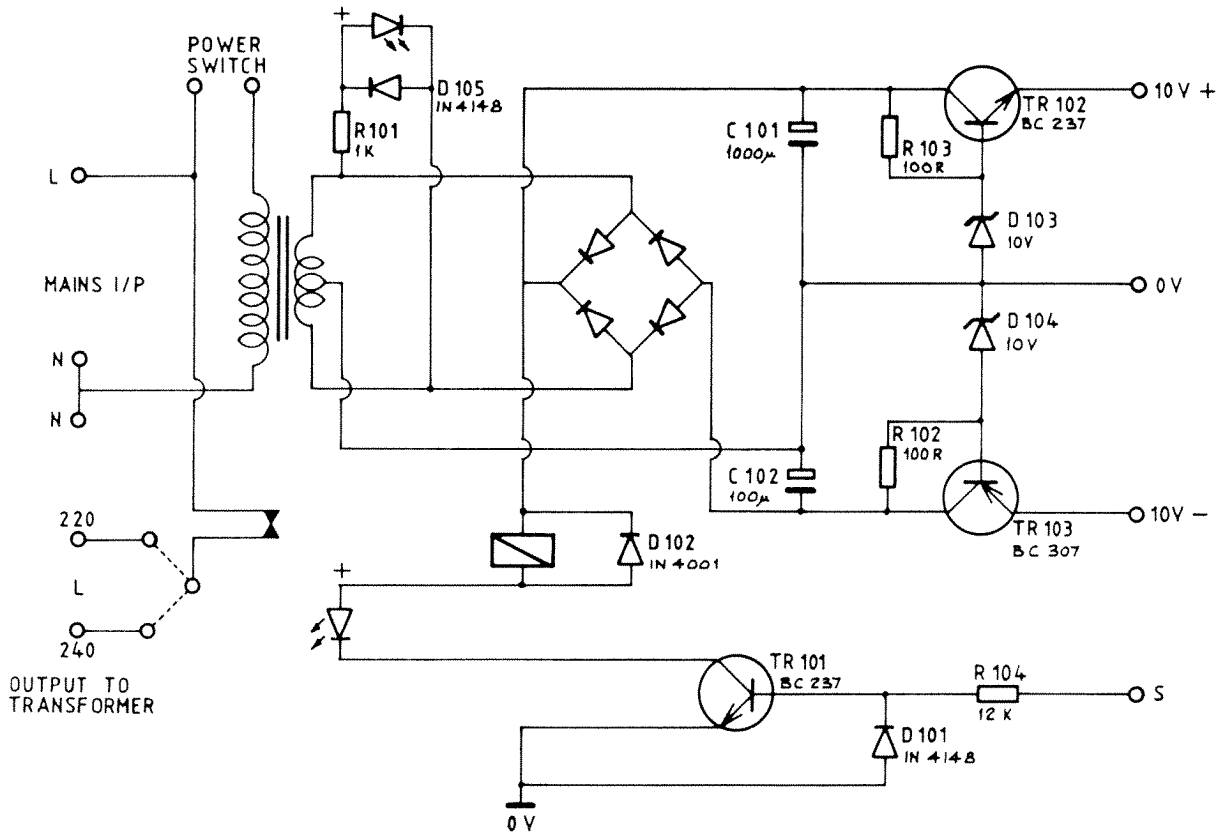
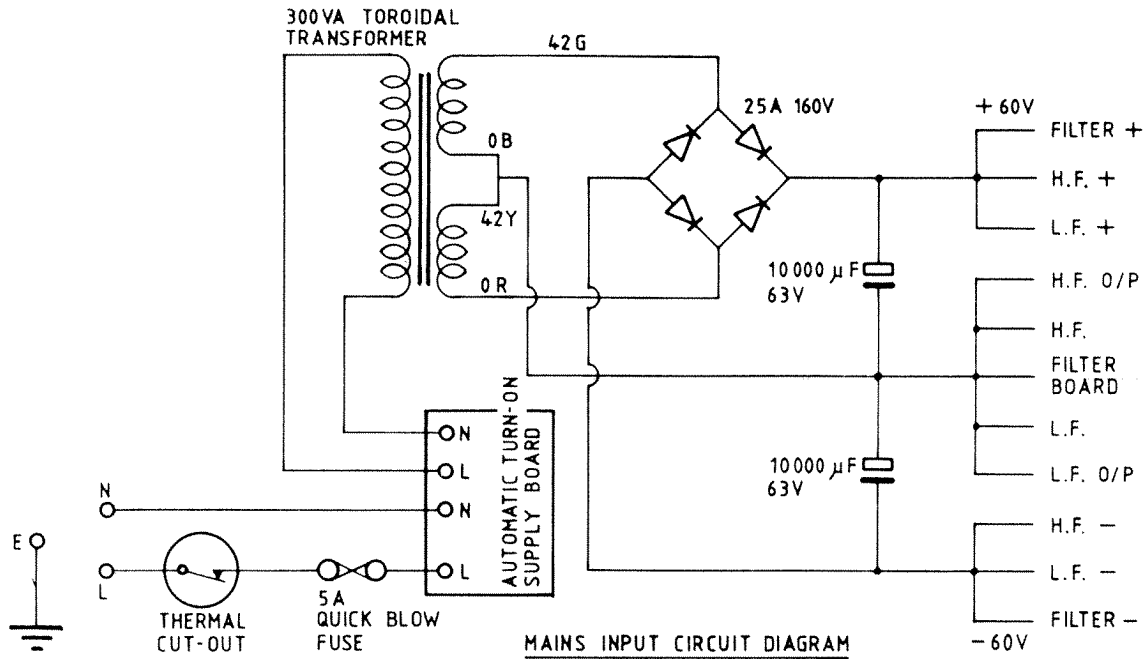

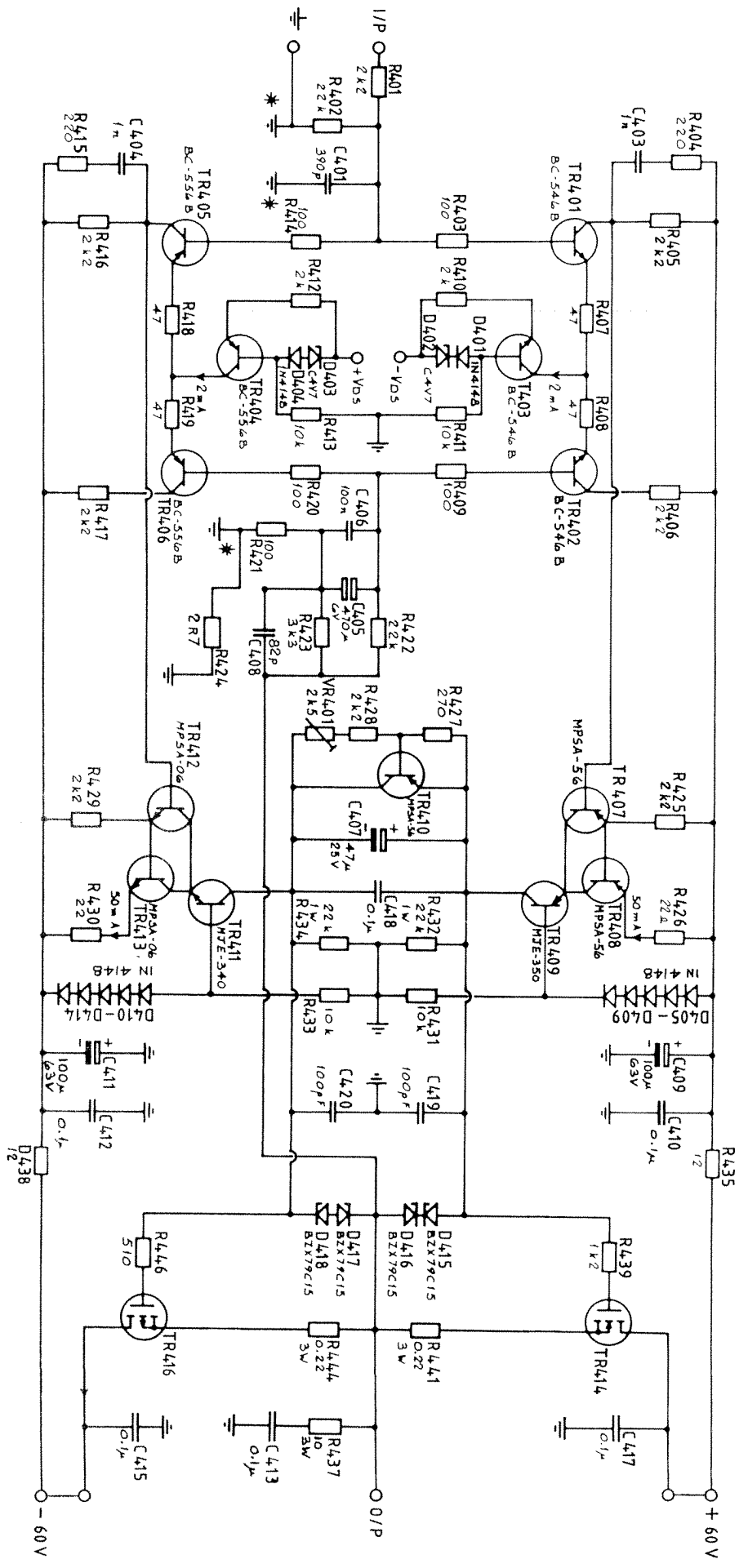

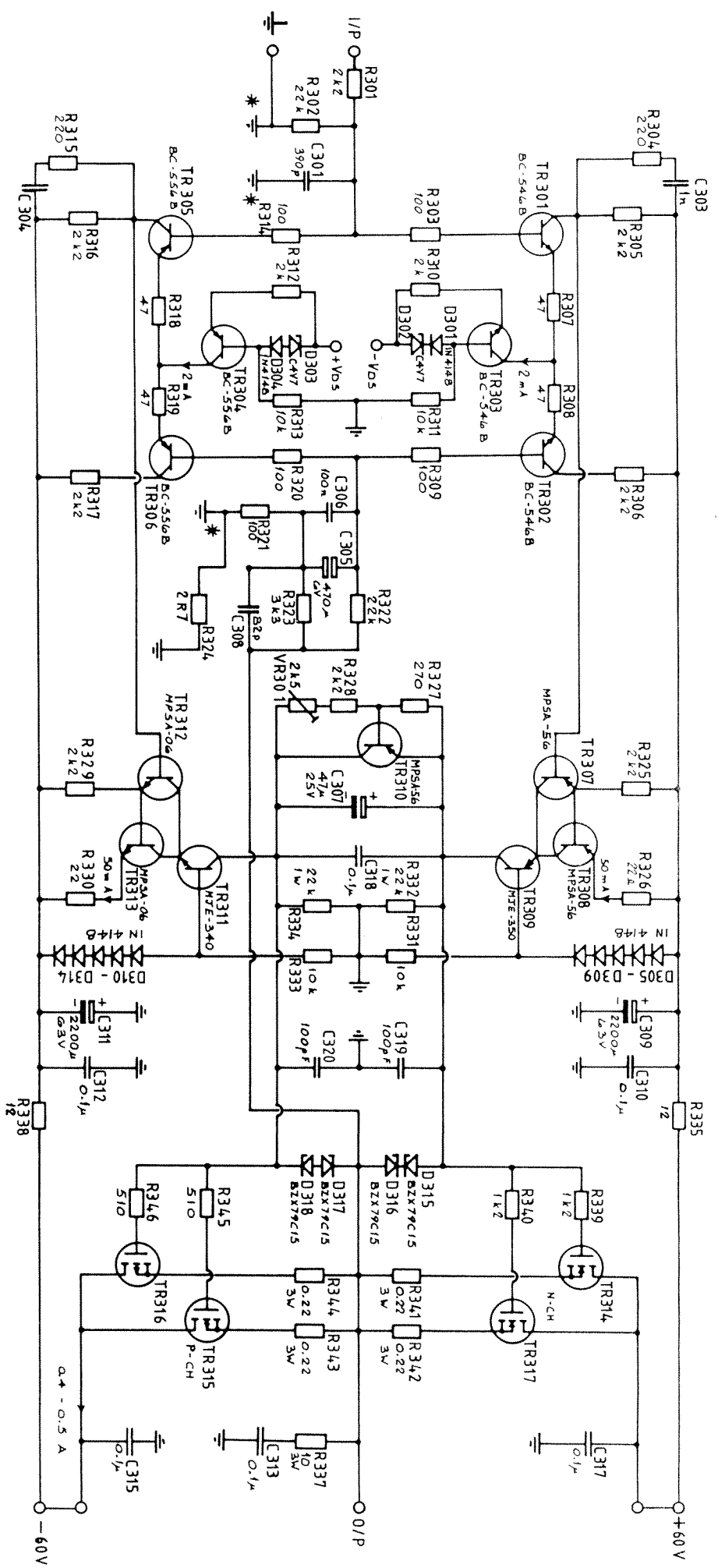

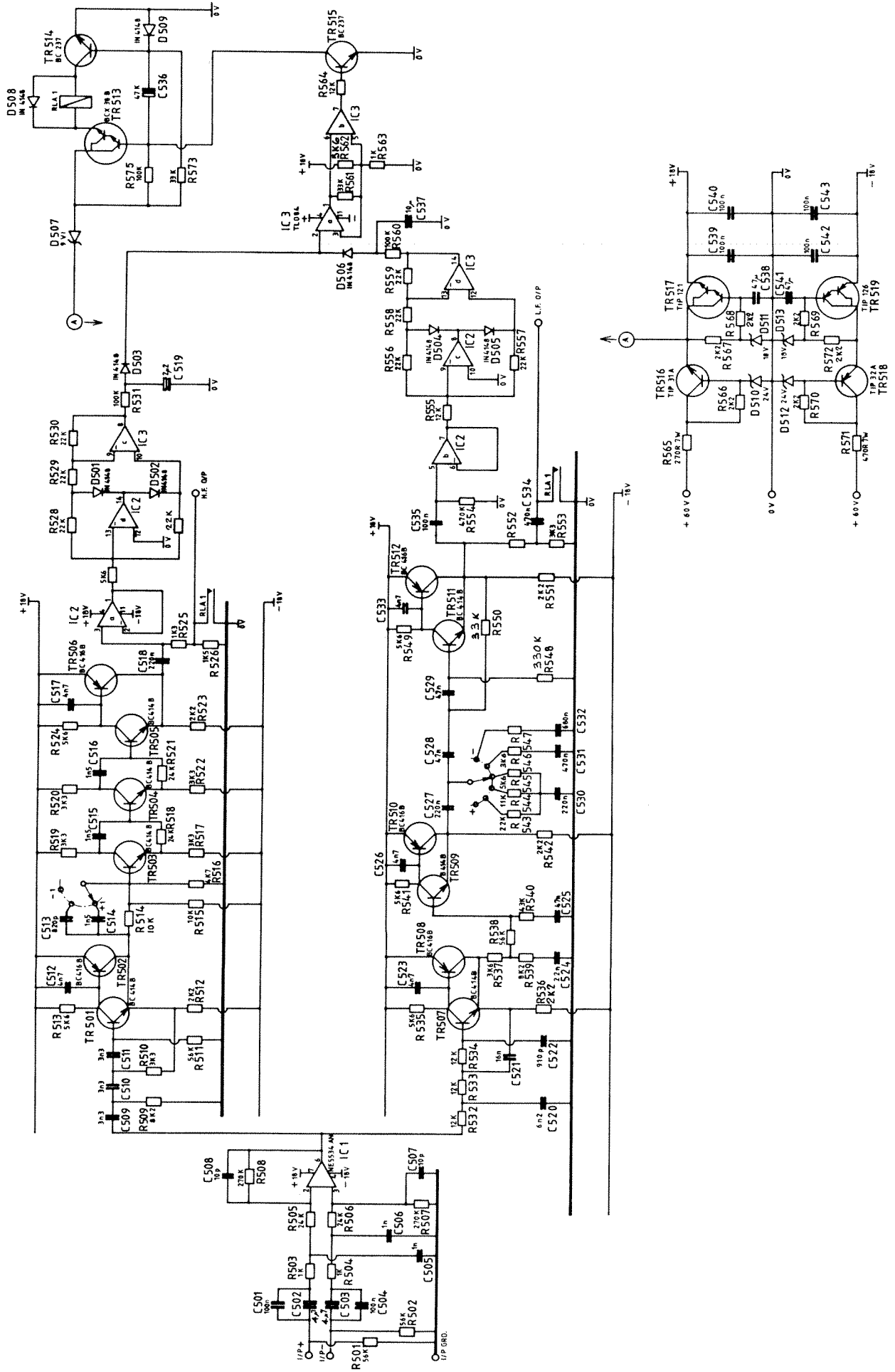

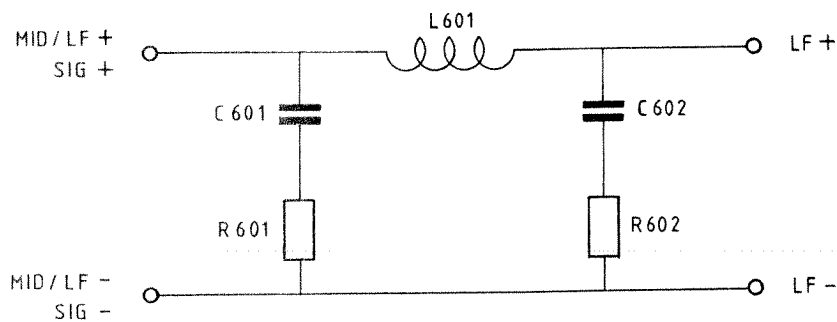

NOTE! CENTRE LINE AXIS OF INDUCTOR
MUST RUN FROM BACK TO FRONT
OF CABINET

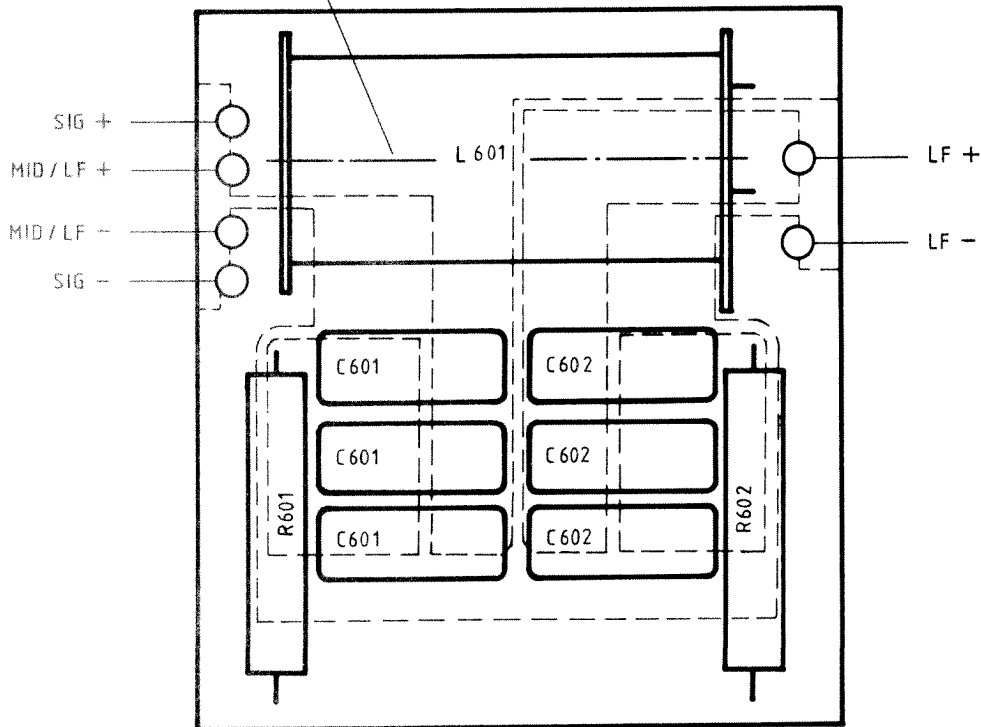

ITEM	QTY.	CODE No.	DESCRIPTION			
C601	1		CAPACITOR	10 μ F	total component value \pm 5%	
C602	1		"	10 μ F	" " "	
L601	1		INDUCTOR	3 mH	1.25mm. dia. wire cored	
R601	1		RESISTOR	10 Ω 7W	ceramic.	
R602	1		"	10 Ω 7W	ceramic.	

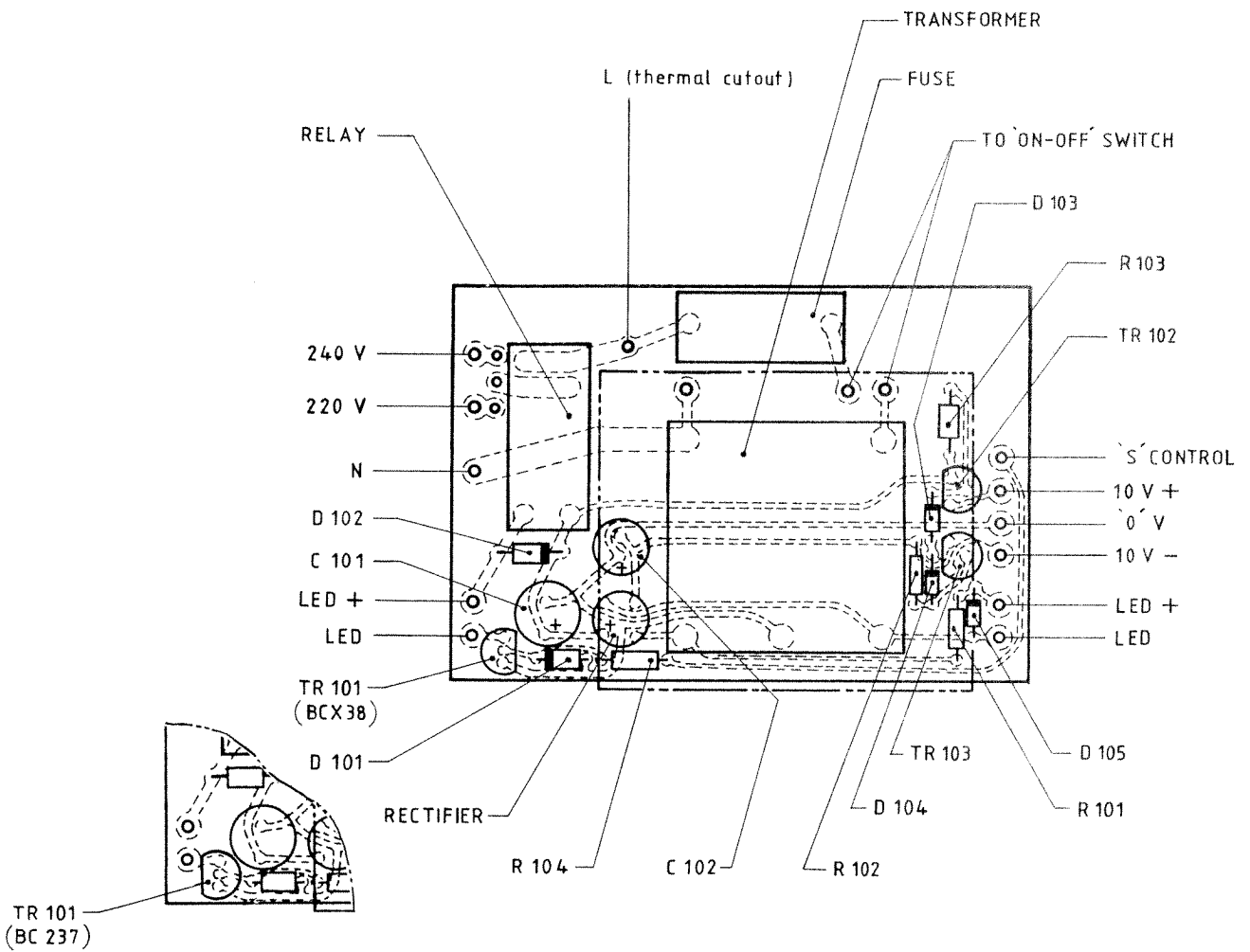

ITEM	QTY.	CODE No.	DESCRIPTION
C101	1		CAPACITOR 470 μ 16 V
C102	1		" 100 μ 16 V
D101	1		DIODE IN 4148
D102	1		" IN 4002
D103	1		" 10 V ZENER
D104	1		" 10 V ZENER
D105	1		" IN 4148
R101	1		RESISTOR 1 K All 0.25 W unless otherwise stated
R102	1		" 100 Ω " "
R103	1		" - 100 R " "
R104	1		" 1 K " "
TR101	1		TRANSISTOR BC 237 or BCX 38
TR102	1		" BC 237
TR103	1		" BC 307
			TRANSFORMER 240 V , 220 V , 110 V OR PRIMARY AS REQUIRED, SECONDARY 9-0-9
			RECTIFIER 1 AMP 50 V (RADIO SPARES 262-141)
			RELAY 12 V COIL 10 AMP SIEMENS V23056 OMRON 62R-117 P-V-RP
			FUSE ANTI-SURGE 100MA

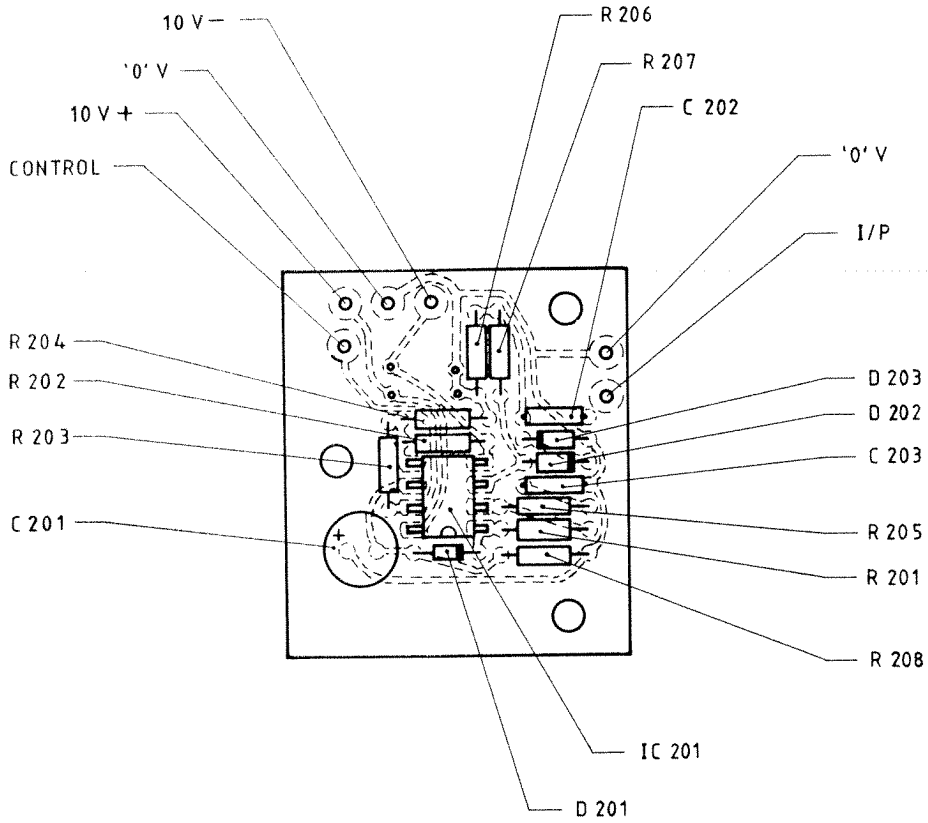

ITEM	QTY.	CODE No.	DESCRIPTION		
C201	1		CAPACITOR	100 uF	25 V
C202	1		"	100 n	
C203	1		"	100 n	
C204					
C205					
D201	1		DIODE	IN 4148	
D202	1		"	4 V 7 ZENER	
D203	1		"	4 V 7 ZENER	
D204					
D205					
R201	1		RESISTOR	8 M 2	all 0.25 W unless otherwise stated.
R202	1		"	12 K	
R203	1		"	33 K	
R204	1		"	6 K 8	
R205	1		"	4 K 7	
R206	1		"	100 K	
R207	1		"	470 K	
R208	1		"	8 M 2	
R209					
R210					
IC201	1		SEMICONDUCTOR	TL082CP	

SEE SHEET 2 FOR COMPONENT LIST.

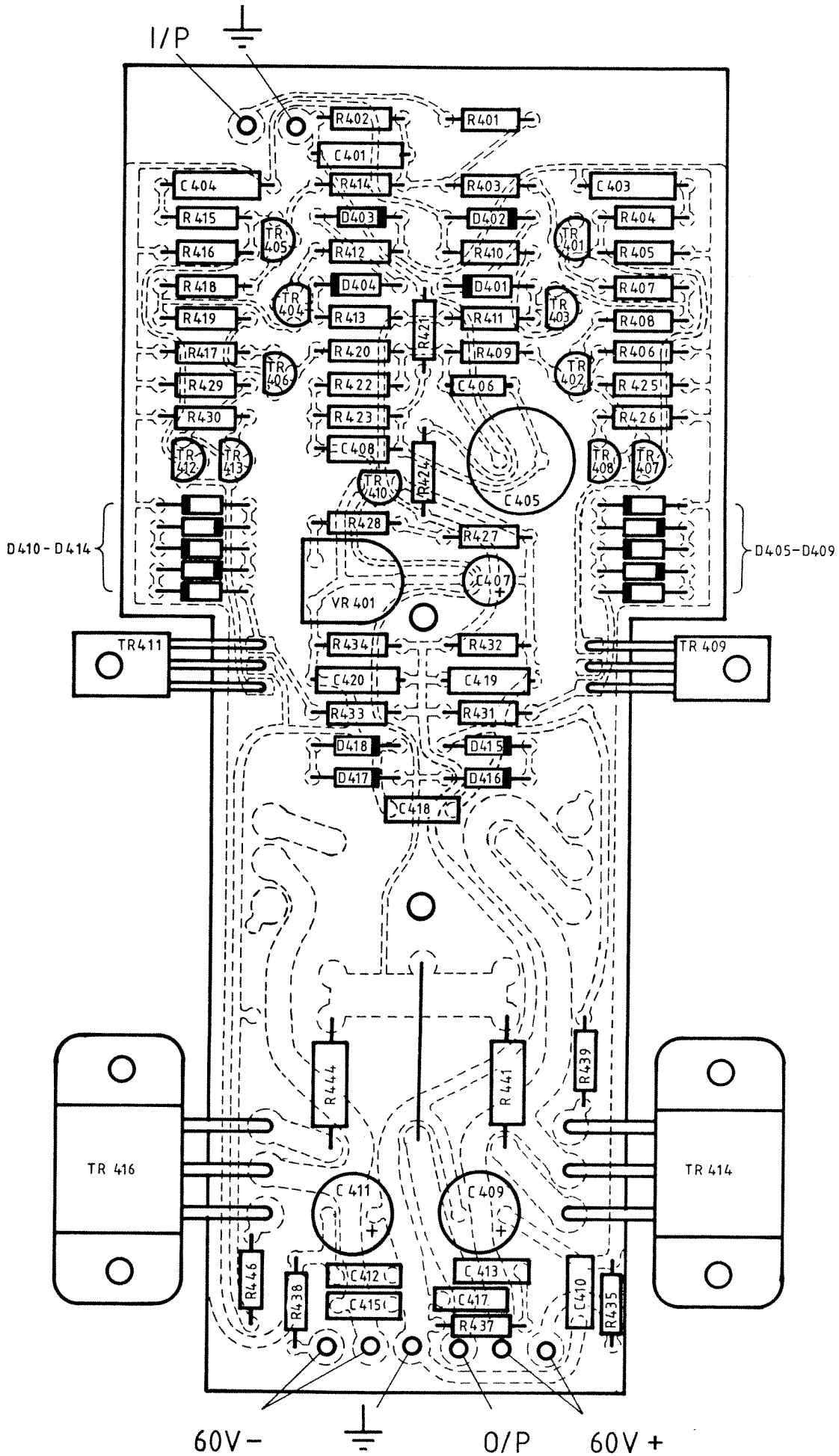

ITEM	QTY.	CODE No.	DESCRIPTION
R427	1	RESISTOR	270 R
R428	1	"	2 K 2
R429	1	"	22 K 2
R430	1	"	22 R
R431	1	"	10 K
R432	1	"	22 K
R433	1	"	10 K
R434	1	"	22 K
R435	1	"	12 R 0.5W carbon film
R436	1	"	10 R
R438	1	"	12 R 0.5W carbon film
R439	1	"	1 K 2
R440	1	"	1 K 2
R441	1	"	0.22 R 2.5W wire wound
R442	1	"	0.22 R 2.5W wire wound
R443	1	"	0.22 R 2.5W wire wound
R444	1	"	0.22 R 2.5W wire wound
R445	1	"	510 R
R446	1	"	510 R
VR401	1	VARIABLE RESISTOR	2 K 5
TR401	1	TRANSISTOR	BC - 546 B * matched pair
TR402	1	"	BC - 546 B *
TR403	1	"	BC - 546 B
TR404	1	"	BC - 556 B
TR405	1	"	BC - 556 B ** matched pair
TR406	1	"	BC - 556 B **
TR407	1	"	MPSA - 56
TR408	1	"	MPSA - 56
TR409	1	"	MJE - 350
TR410	1	"	MPSA - 56
TR411	1	"	MJE - 340
TR412	1	"	MPSA - 06
TR413	1	"	MPSA - 06
TR414	1	"	K 343
TR415	1	"	J 99
TR416	1	"	J 99
TR417	1	"	K 343

ITEM	QTY.	CODE No.	DESCRIPTION
C401	1	CAPACITOR	390 P
C402	1	"	polystyrene
C403	1	"	"
C404	1	"	1 n
C405	1	"	1 n
C406	1	"	470 μ 6V bi-polar electrolytic
C407	1	"	0.1 μ polyester
C408	1	"	47 μ 25V electrolytic
C409	1	"	82 p polystyrene
C410	1	"	100 μ 63V electrolytic
C411	1	"	0.1 μ polyester
C412	1	"	100 μ 63V electrolytic
C413	1	"	0.1 μ polyester
C414	1	"	0.1 μ polyester
C415	1	"	0.1 μ polyester
C416	1	"	0.1 μ polyester
C417	1	"	0.1 μ polyester
C418	1	"	0.1 μ polyester
C419	1	"	100 p polystyrene
C420	1	"	100 p polystyrene
D401	1	DIODE	IN 4148
D402	1	"	BZX 79 C 4 V 7
D403	1	"	BZX 79 C 4 V 7
D404	1	"	IN 4148
D405	1	"	IN 4148
D406	1	"	IN 4148
D407	1	"	IN 4148
D408	1	"	IN 4148
D409	1	"	IN 4148
D410	1	"	IN 4148
D411	1	"	IN 4148
D412	1	"	IN 4148
D413	1	"	IN 4148
D414	1	"	IN 4148
D415	1	"	BZX 79 C 15
D416	1	"	BZX 79 C 15
D417	1	"	BZX 79 C 15
D418	1	"	BZX 79 C 15
R401	1	RESISTOR	2 K 2
R402	1	"	22 K
R403	1	"	100 R
R404	1	"	220 R
R405	1	"	2 K 2
R406	1	"	2 K 2
R407	1	"	47 R
R408	1	"	47 R
R409	1	"	100 R
R410	1	"	2 K
R411	1	"	10 K
R412	1	"	2 K
R413	1	"	10 K
R414	1	"	100 R
R415	1	"	220 R
R416	1	"	2 K 2
R417	1	"	2 K 2
R418	1	"	47 R
R419	1	"	47 R
R420	1	"	100 R
R421	1	"	100 R
R422	1	"	22 K
R423	1	"	22 K
R424	1	"	3 K 3
R425	1	"	2 R 7
R426	1	"	2 K 2
R427	1	"	22 R

SEE SHEET 2 FOR COMPONENT LIST.

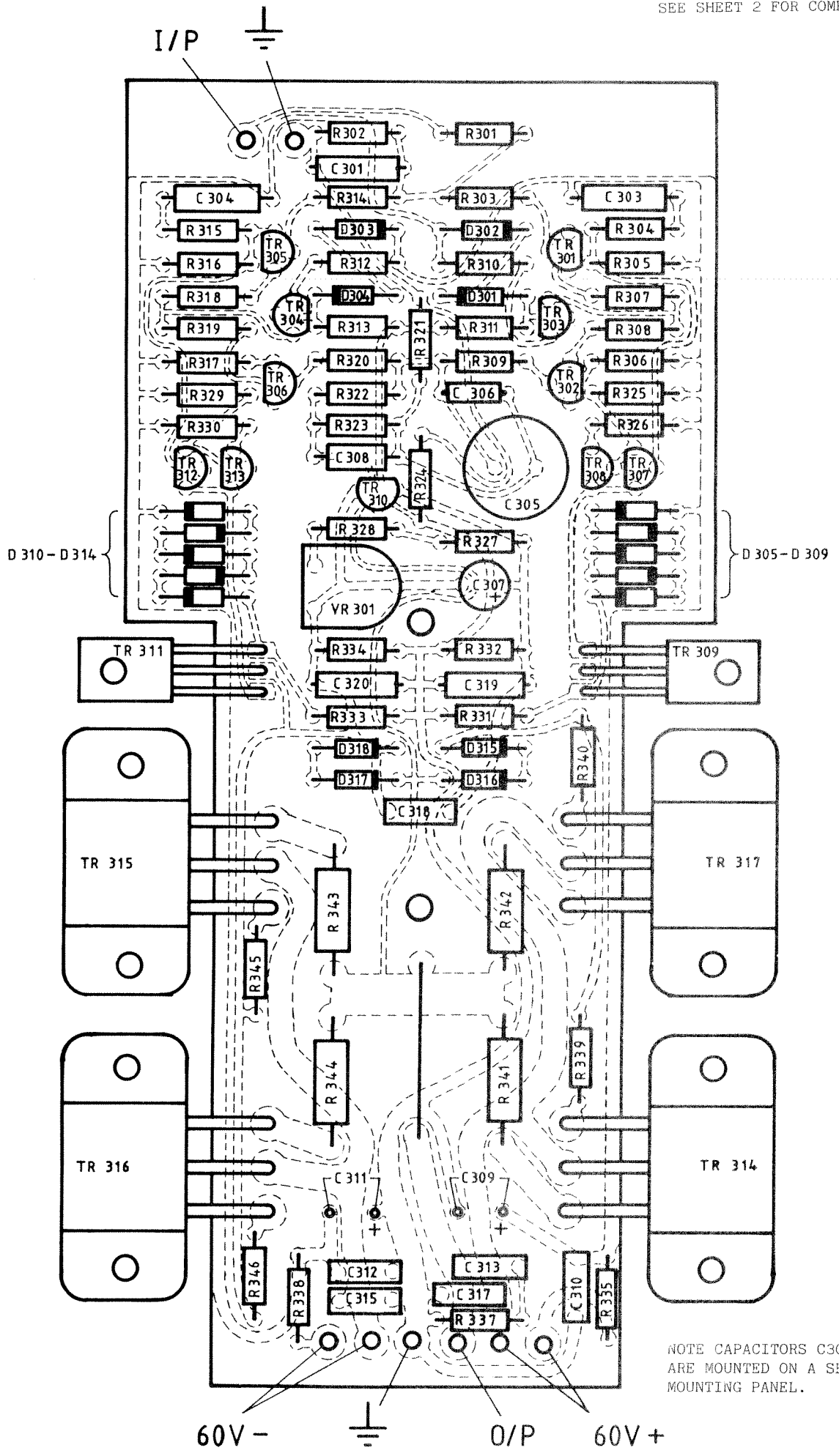

NOTE CAPACITORS C309 & C311 ARE MOUNTED ON A SEPARATE MOUNTING PANEL.

ITEM	QTY.	CODE No.	DESCRIPTION
R327	1		RESISTOR 270 R all 0.25 W metal film unless otherwise stated.
R328	1		" 2 K 2
R329	1		" 2 K 2
R330	1		" 22 R
R331	1		" 10 K
R332	1		" 22 K
R333	1		" 10 K
R334	1		" 22 K
R335	1		" 12 R 0.5 W carbon film
R336	1		" 10 R
R338	1		" 12 R 0.5 W carbon film
R339	1		" 1 K 2
R340	1		" 1 K 2
R341	1		" 0.22 R 2.5 W wire wound
R342	1		" 0.22 R 2.5 W wire wound
R343	1		" 0.22 R 2.5 W wire wound
R344	1		" 0.22 R 2.5 W wire wound
R345	1		" 510 R
R346	1		" 510 R
VR301	1		VARIABLE RESISTOR 2 K 5
TR301	1		TRANSISTOR BC - 546 B * matched pair
TR302	1		" BC - 546 B *
TR303	1		" BC - 546 B
TR304	1		" BC - 546 B
TR305	1		" BC - 546 B ** matched pair
TR306	1		" BC - 546 B **
TR307	1		" MP5A - 56
TR308	1		" MP5A - 56
TR309	1		" MJE - 350
TR310	1		" MP5A - 56
TR311	1		" MJE - 340
TR312	1		" MP5A - 06
TR313	1		" MP5A - 06
TR314	1		" K 343
TR315	1		" J 99
TR316	1		" J 99
TR317	1		" K 343

ITEM	QTY.	CODE No.	DESCRIPTION
C301	1		CAPACITOR 390 p polystyrene
C302	1		" 1 n "
C303	1		" 1 n "
C304	1		" 470 μ 6 V bi-polar electrolytic
C305	1		" 0.1 μ polyester
C306	1		" 0.1 μ 25 V electrolytic
C307	1		" 82 p polystyrene
C308	1		" 2200 μ 63 V electrolytic
C309	1		" 0.1 μ polyester
C310	1		" 2200 μ 63 V electrolytic
C311	1		" 0.1 μ polyester
C312	1		" 0.1 μ polyester
C313	1		" 0.1 μ polyester
C314	1		" 0.1 μ polyester
C315	1		" 0.1 μ polyester
C316	1		" 0.1 μ polyester
C317	1		" 0.1 μ polyester
C318	1		" 0.1 μ polyester
C319	1		" 100 p polystyrene
C320	1		" 100 p polystyrene
D301	1		DIODE IN 4148
D302	1		" BZX 79 C 4 V 7
D303	1		" BZX 79 C 4 V 7
D304	1		" IN 4148
D305	1		" IN 4148
D306	1		" IN 4148
D307	1		" IN 4148
D308	1		" IN 4148
D309	1		" IN 4148
D310	1		" IN 4148
D311	1		" IN 4148
D312	1		" IN 4148
D313	1		" IN 4148
D314	1		" IN 4148
D315	1		" BZX 79 C 15
D316	1		" BZX 79 C 15
D317	1		" BZX 79 C 15
D318	1		" BZX 79 C 15
R301	1		RESISTOR 2 K 2 all 0.25 W metal film unless otherwise
R302	1		" 22 K
R303	1		" 100 R
R304	1		" 220 R
R305	1		" 2 K 2
R306	1		" 2 K 2
R307	1		" 47 R
R308	1		" 47 R
R309	1		" 100 R
R310	1		" 2 K
R311	1		" 10 K
R312	1		" 2 K
R313	1		" 10 K
R314	1		" 100 R
R315	1		" 220 R
R316	1		" 2 K 2
R317	1		" 2 K 2
R318	1		" 47 R
R319	1		" 47 R
R320	1		" 100 R
R321	1		" 100 R
R322	1		" 22 K
R323	1		" 3 K 3
R324	1		" 2 R 7
R325	1		" 2 K 2
R326	1		" 22 R

SEE SHEETS 2 AND 3 FOR COMPONENT LISTS.

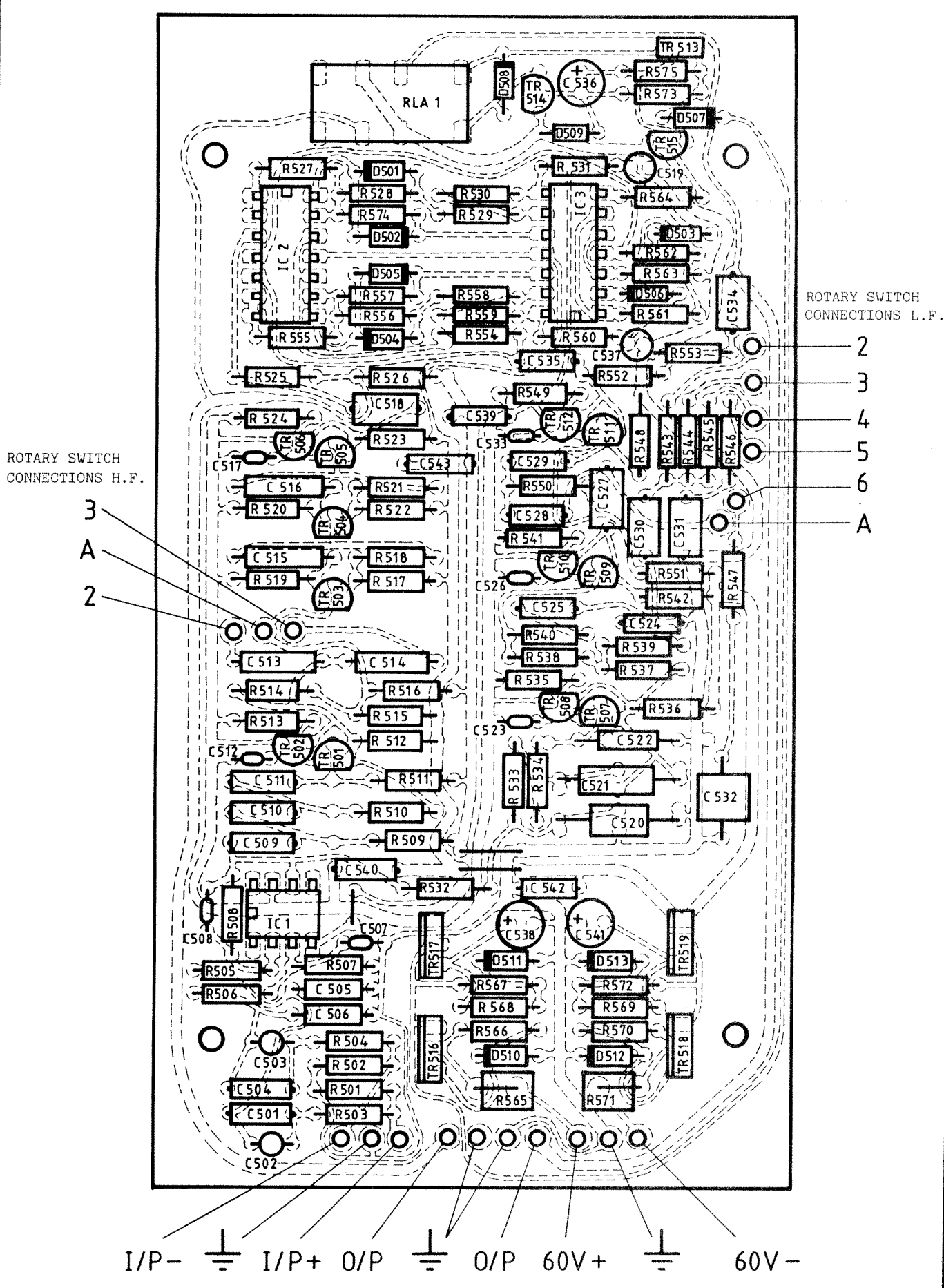

ROTARY SWITCH CONNECTIONS H.F.

ROTARY SWITCH CONNECTIONS L.F.

3
A
2

2
3
4
5
6
A

I/P- \perp I/P+ O/P \perp O/P 60V+ \perp 60V-

ITEM	QTY.	CODE No.	DESCRIPTION
R509	1		RESISTOR 8 K2
R510	1		" 3 K3
R511	1		" 56 K
R512	1		" 2 K2
R513	1		" 5 K6
R514	1		" 10 K
R515	1		" 10 K
R516	1		" 4 K7
R517	1		" 3 K3
R518	1		" 24 K
R519	1		" 3 K3
R520	1		" 3 K3
R521	1		" 24 K
R522	1		" 3 K3
R523	1		" 2 K2
R524	1		" 5 K6
R525	1		" 1 K3
R526	1		" 1 K5
R527	1		" 5 K6
R528	1		" 22 K
R529	1		" 22 K
R530	1		" 22 K
R531	1		" 100 K
R532	1		" 12 K
R533	1		" 12 K
R534	1		" 12 K
R535	1		" 5 K6
R536	1		" 2 K2
R537	1		" 3 K6
R538	1		" 56 K
R539	1		" 8 K2
R540	1		" 43 K
R541	1		" 5 K6
R542	1		" 2 K2
R543	1		" 22 K
R544	1		" 11 K
R545	1		" 5 K6
R546	1		" 3 K6
R547	1		" 2 K7
R548	1		" 330 K
R549	1		" 5 K6
R550	1		" 33 K
R551	1		" 2 K2
R552	1		" 4 K7
R553	1		" 3 K3
R554	1		" 470 K
R555	1		" 12 K
R556	1		" 22 K
R557	1		" 22 K
R558	1		" 22 K
R559	1		" 22 K
R560	1		" 100 K
R561	1		" 33 K
R562	1		" 5 K6
R563	1		" 1 K
R564	1		" 12 K
R565	1		" 270 R 7 W wire wound
R566	1		" 2 K2
R567	1		" 2 K2
R568	1		" 2 K2
R569	1		" 2 K2
R570	1		" 2 K2
R571	1		" 470 R 7 W wire wound
R572	1		" 2 K2
R573	1		" 100 K
R574	1		" 22 K
R575	1		" 33 K

ITEM	QTY.	CODE No.	DESCRIPTION
C501	1		100 n polyester
C502	1		4 μ7 tantalum
C503	1		4 μ7 tantalum
C504	1		100 n polyester
C505	1		1 n polystyrene
C506	1		1 n polystyrene
C507	1		10 p ceramic
C508	1		10 p ceramic
C509	1		3 n3 polyester
C510	1		3 n3 polyester
C511	1		3 n3 polyester
C512	1		4 n7 ceramic
C513	1		820 p polystyrene
C514	1		1 n5 polystyrene
C515	1		1 n5 polystyrene
C516	1		1 n5 polystyrene
C517	1		4 n7 ceramic
C518	1		220 n polyester
C519	1		2 μ2 63 V electrolytic
C520	1		6 n2 polystyrene
C521	1		16 n polystyrene
C522	1		910 p polystyrene
C523	1		4 n7 ceramic
C524	1		22 n polyester
C525	1		47 n polyester
C526	1		4 n7 ceramic
C527	1		220 n polyester
C528	1		47 n polyester
C529	1		47 n polyester
C530	1		220 n polyester
C531	1		470 n polyester
C532	1		680 n polyester
C533	1		4 n7 ceramic
C534	1		470 n polyester
C535	1		100 n polyester
C536	1		47 μ electrolytic
C537	1		10 μ 25 V electrolytic
C538	1		47 μ 25 V electrolytic
C539	1		100 n polyester
C540	1		100 n polyester
C541	1		47 μ 25 V electrolytic
C542	1		100 n polyester
C543	1		100 n polyester
D501	1		IN 4148 DIODE
D502	1		IN 4148
D503	1		IN 4148
D504	1		IN 4148
D505	1		IN 4148
D506	1		IN 4148
D507	1		BZX 79 C 9 V1 zener
D508	1		IN 4148
D509	1		IN 4148
D510	1		BZX 79 C 24 V zener
D511	1		BZX 79 C 18 V zener
D512	1		BZX 79 C 24 V zener
D513	1		BZX 79 C 10 V zener
R501	1		RESISTOR 56 K all 0.25W metal film unless otherwise stated.
R502	1		" 56 K
R503	1		" 1 K
R504	1		" 1 K
R505	1		" 24 K
R506	1		" 24 K
R507	1		" 100 K
R508	1		" 100 K

ITEM	QTY.	CODE No.	DESCRIPTION
TR501	1		TRANSISTOR BC 414
TR502	1		" BC 416
TR503	1		" BC 414
TR504	1		" BC 414
TR505	1		" BC 414
TR506	1		" BC 416
TR507	1		" BC 414
TR508	1		" BC 416
TR509	1		" BC 414
TR510	1		" BC 416
TR511	1		" BC 414
TR512	1		" BC 416
TR513	1		" BCX 38 B
TR514	1		" BC 237
TR515	1		" BC 237
TR516	1		" TIP 31 A
TR517	1		" TIP 121
TR518	1		" TIP 32 A
TR519	1		" TIP 126
IC 1	1		SEMICONDUCTOR NE 5534 AN
IC 2	1		" TLO 84
IC 3	1		" TLO 84
RLA 1	1		RELAY B&R V23102A 0006A201 or R.S. 346845

BIAS ADJUSTMENT OF POWER AMPLIFIERS

Before adjusting the bias, the amplifiers must be left turned on for a minimum of half an hour, which necessitates a small audio signal being applied to the input to prevent the automatic switch-off of the circuitry. This audio signal must be removed whilst bias measurements are being made and the connection to the loudspeaker drive units removed.

In the case of the high-frequency amplifier, a millivolt-meter is used in parallel with R444, and preset resistor VR401 is adjusted to give a reading of between 35 and 40 millivolts. The same reading should then be obtained across R441.

In the case of the bass amplifier, a similar procedure is carried out, but VR301 should be adjusted so that the average reading across resistors R344 and R343 is 35 to 40 millivolts.