

The JBL logo is displayed in white, bold, sans-serif capital letters within a solid black square.

S E R V I C E M A N U A L

ARC SUB

Discrete Output, High Current
8" Powered Subwoofer



JBL Consumer Products Inc.
250 Crossways Park Drive
Woodbury, N.Y. 11797

H A Harman International Company

1112-ARCSUB Rev A 4/98

TABLE OF CONTENTS

Specifications	1	Block Diagram	7
Warranty	2	Amplifier Exploded View	8
Safety Symbols	2	Cabinet Exploded View	9
Controls and Their Functions.....	3	Parts Lists.....	10
Test Procedures	4	Packaging and Shipping	12
Trouble Shooting Before Opening	5	Integrated Circuit Diagrams	13
Removing the Amplifier.....	5	Printed Circuit Boards	14
Trouble Shooting After Removal	5	Schematic Diagrams	16
Components Requiring Exact Replacement.....	6		

SPECIFICATIONS

Amplifier Power RMS	75 Watts
Drivers	8" with high-polymer-laminated cones
Inputs	Line level and High Level
Outputs*	High level with High-Pass filter at 180Hz
Crossover Frequency (continuously variable)	50-150Hz
Frequency Response (determined by crossover setting)	45Hz to (50 - 150Hz)

External Dimensions (Inches)

Height	9 1/4"
Width	14"
Depth	12 1/2"
Weight	23 lbs

External Dimensions (mm)

Height	235 mm
Width	356 mm
Depth	318 mm
Weight	10.5 kg

* High-Level (speaker) outputs are active only if high-level input are used.

Occasional refinements may be made to existing products without notice, but will always meet or exceed original specifications unless otherwise stated.

WARRANTY

This amplifier is warranted against defects in material and workmanship for a period of 90 days from date of shipment, when installed in accordance with the owner's manual in a clean, dry, interior home environment. **THIS AMPLIFIER IS NOT SUITABLE FOR OPERATION OUTSIDE OR IN HARSH ENVIRONMENTS.** During the warranty period, the manufacturer will, at its option, either repair or replace products which prove to be defective.

For warranty service or repair, this product must be properly packed and returned to a service facility designated by the manufacturer. Buyer shall prepay shipping charges to the designated facility and the manufacturer shall pay shipping charges to return the product to buyer. However, Buyer shall pay all shipping charges, duties and taxes for products returned to the manufacturer from another country.

The manufacturer does not warrant that the operation of the product will be uninterrupted or error-free. The Buyer must determine the suitability of the product for his or her purposes.

LIMITATION OF WARRANTY

The foregoing warranty shall not apply to defects resulting from improper or inadequate maintenance by Buyer, Buyer-supplied interfacing, unauthorized modification or misuse, operation outside of the environment specifications for the product including inadequate ventilation, or improper site preparation, installation, or maintenance.

NO OTHER WARRANTY IS EXPRESSED OR IMPLIED. THE MANUFACTURER SPECIFICALLY DISCLAIMS THE IMPLIED WARRANTIES OF MERCHANTABILITY AND FITNESS FOR A PARTICULAR PURPOSE.

EXCLUSIVE REMEDIES

THE REMEDIES PROVIDED HEREIN ARE BUYER'S SOLE AND EXCLUSIVE REMEDIES. THE MANUFACTURER SHALL NOT BE LIABLE FOR ANY DIRECT, INDIRECT, SPECIAL, INCIDENTAL, OR CONSEQUENTIAL DAMAGES, WHETHER BASED ON CONTRACT, TORT, OR ANY OTHER LEGAL THEORY.

SAFETY SYMBOLS

The following symbols are used throughout this manual and in the product. Familiarize yourself with each of the symbols and its meaning before servicing this amplifier.



Instruction manual symbol. The product will be marked with this symbol when it is necessary for the user to refer to the instruction manual in order to protect the unit against damage.



Indicates dangerous voltages are present. Be extremely careful.

CAUTION

The **CAUTION** sign denotes a hazard. It calls attention to a procedure which, if not correctly performed or adhered to, could result in damage to or destruction of the amplifier. Do not proceed beyond a **CAUTION** sign until the indicated conditions are fully understood and met.

WARNING

The **WARNING** sign denotes a hazard. It calls attention to a procedure which, if not correctly performed or adhered to could result in injury or loss of life. Do not proceed beyond a

WARNING sign until the indicated conditions are fully understood and met.

GENERAL SAFETY CONSIDERATIONS

THIS UNIT DOES NOT HAVE A POWER SWITCH;

WARNING

HAZARDOUS VOLTAGES ARE PRESENT WITHIN THE UNIT WHENEVER IT IS PLUGGED IN. This still applies when the over-temperature thermostat opens, as it may automatically reset at any time.

WARNING

There are voltages and hot components at many points in the amplifier which can, if contacted, cause serious injury. Be extremely careful. Any adjustments or service procedures that require operation of the amplifier out of its enclosure should be performed only by trained service personnel.

CONTROLS AND THEIR FUNCTION

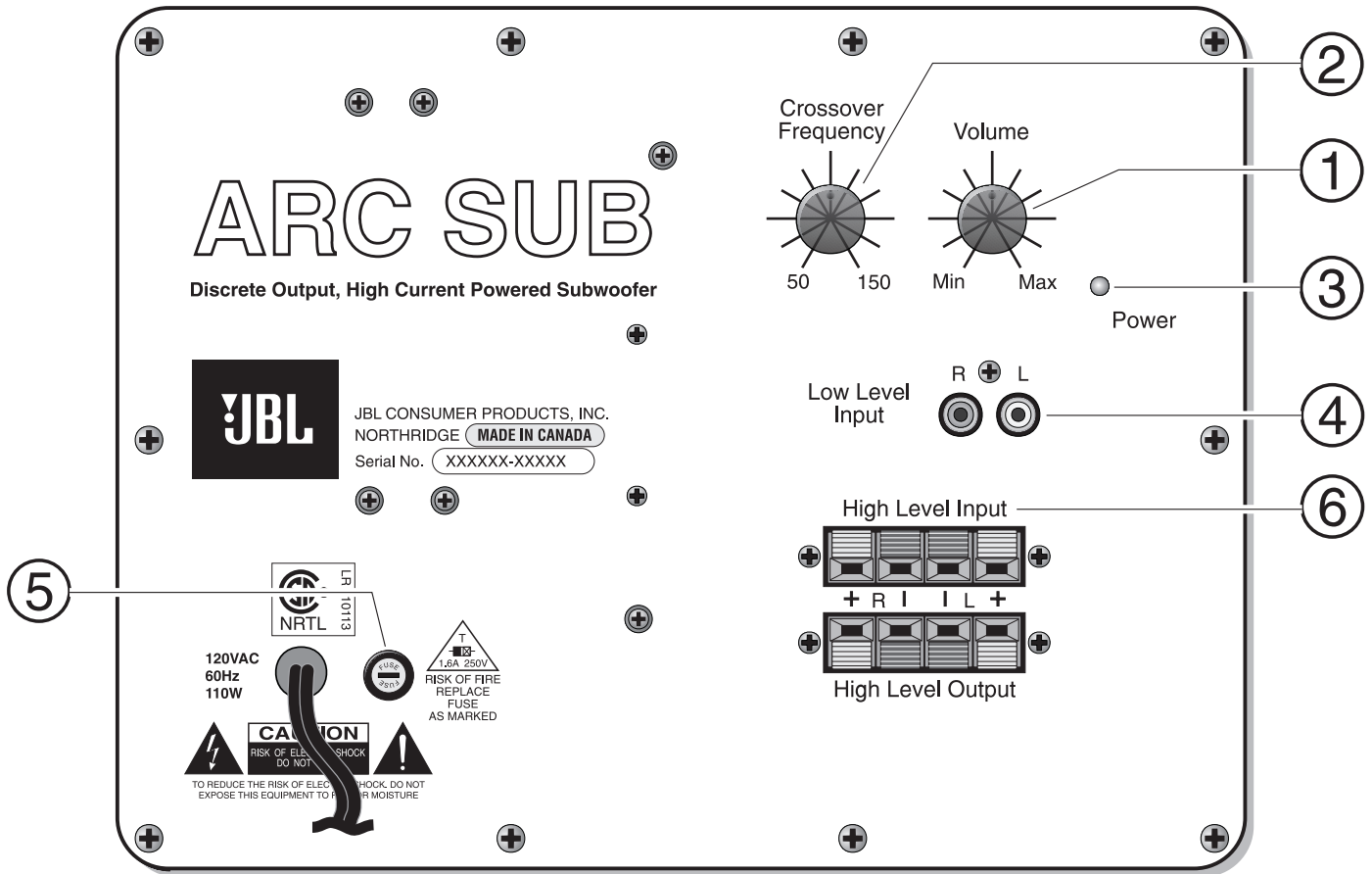

1. **Output Level** - The Output Level adjustment determines volume level strength.
2. **Crossover Frequency** - The Crossover Frequency adjustment determines the highest frequency the ARC SUB will reproduce. It allows a seamless transition from the subwoofer to the satellite speakers.
3. **On (LED)** - This LED will light green when the unit is plugged in and is receiving signal. When in standby mode the LED is red.
4. **Low Level Input** - These left and right Line Level Inputs are normally used when the receiver/processor has line-level “pre-amp out” or “subwoofer out” jacks.
5. **Fuse** - Use only a slow-blo 1.0A 250V GMC fuse.
6. **High Level Inputs** - These High Level Inputs are for receivers that do not have line-level “pre-amp out” or “subwoofer out” jacks. When a pair of main or satellite speakers are attached to the OUTPUT terminals, frequencies below 180 Hz are attenuated by the high-pass filter.

TEST PROCEDURES

EQUIPMENT

- Function generator/signal generator/sweep generator
- Integrated Amplifier
- Multimeter
- Cables - line level (RCA) and speaker cables

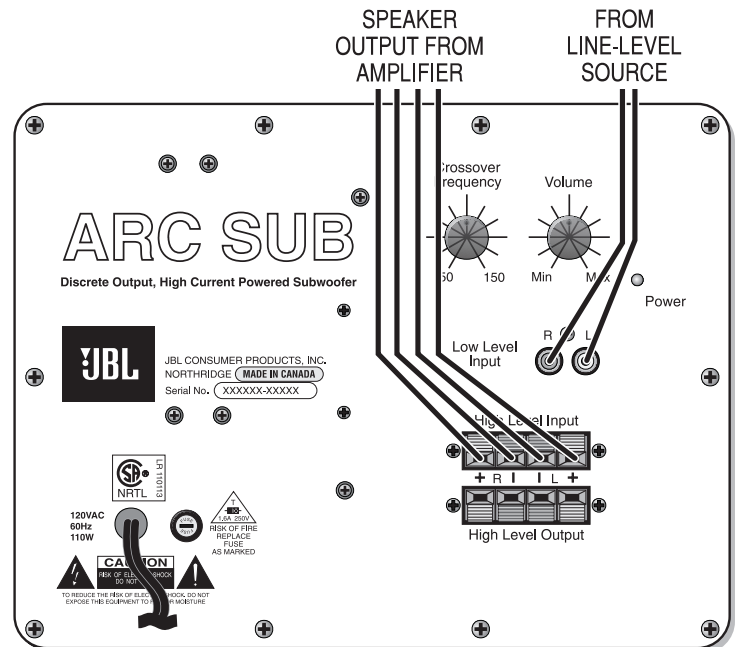
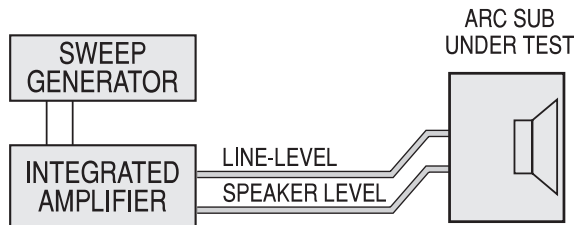

General Function

UUT = Unit Under Test

1. Connect both right and left line level inputs (RCA) to signal generator and UUT. Use Y-cable if necessary from mono source. VOLUME control should be full counterclockwise.
2. Turn on generator, adjust to **50mV, 50 Hz**.
3. Plug in UUT; red LED should be ON. Turn VOLUME control full clockwise.
4. LED should turn Green; immediate bass response should be heard and felt from port tube opening.
5. Turn off generator, turn VOLUME control fully counterclockwise, disconnect RCA cables.
6. Connect one pair of speaker cables to either high level input terminal on UUT. Cables should be connected to an integrated amplifier fed by the signal generator.
7. Turn on generator and adjust so that speaker level output is 2.0V, 50 Hz. Turn VOLUME control full clockwise.
8. Green LED should light, immediate bass response should be heard and felt from the port tube opening.

Sweep Function

1. Follow steps 1-4 above, using a sweep generator as a signal source.
2. Sweep generator from 20Hz to 300Hz. Listen to the cabinet and drivers for any rattles, clicks, buzzes or any other noises. If any unusual noises are heard, remove driver and test.

Driver Function

1. Remove driver from cabinet; detach + and - wire clips.
2. Check DC resistance of driver; it should be **3.0** ohms.
3. Connect a pair of speaker cables to driver terminals. Cables should be connected to an integrated amplifier fed by a signal generator and adjust so that speaker level output is **5.0V**.
4. Sweep generator from 20Hz to 1kHz. Listen to driver for any rubbing, buzzing, or other unusual noises.

CAUTION

BEFORE THIS AMPLIFIER IS PLUGGED IN, make sure its rated voltage corresponds to the voltage of the AC power source to be employed. Failure to use the correct voltage could cause damage to the amplifier when the AC power cable is plugged in. Do not exceed the rated voltage by more than 10%; operation below 90% will degrade performance or cause the unit to shut off.

1. TROUBLE SHOOTING BEFORE OPENING

Check connections, control settings, driver and other possible external problems. If there is Output, determine if all controls and Inputs function properly. Rotate Pots over full range while applying lateral and vertical oscillating forces to locate possible intermittent function. High Level Inputs should be tested individually both differentially (signal from "-" to "+" with normal output) and in common mode (signal from low level ground to both "+" and "-" shorted together, giving virtually no output). While passing a signal, corner drop the enclosure a few inches to expose possible intermittent problems. Check woofer for rubbing of voice coil or tears in cone or surround. Check cabinet for loose extraneous articles which may have been pushed into front port.



2. REMOVING THE AMPLIFIER.

WARNING

There are voltages and hot components at many points in the amplifier which can, if contacted, cause personal injury. Be extremely careful. Any adjustments or service procedures that require operation of the amplifier out of its enclosure should be performed only by trained service personnel. Refer to PCB drawings for locations of hazards and familiarize yourself with their locations before starting.

3. TROUBLE SHOOTING AFTER REMOVAL

WARNING

Verify AC plug is disconnected. See WARNINGS in section 2.

WARNING

To prevent loose hardware from reducing safety spacings, it is essential that all hardware be replaced in the same manner as it was removed, with lock washers under all nuts, proper torque on screws and thread locking sealer on the transformer nuts.

CAUTION

If line core, its strain relief, or the AC switch are replaced, it is necessary to seal them completely to panel with an approved conformal coating to prevent air "whistling" through any openings from woofer pressure.

WARNING

To reduce the risk of electric shock and/or fire, replace items as marked on schematic with the safety marking only with the exact replacements listed in the safety component list, section 5. If exact replacements are not available, order them from the factory or an authorized service center.



- A.) Check fuse F1. If blown visually check transformer for discoloration, and large capacitors (C36, C37) for bulges or venting. Check for shorts in Q3-Q7 with an Ohmmeter, (see schematic).
- B. With ohmmeter, verify contacts of thermostat are closed, voice coil of woofer is 3.0 ohms, and windings of transformer are continuous.
- C. Examine board and wiring for obvious damage, broken or poorly soldered connections, or discoloration.
- D. Repair or replace items identified above. Procedures for replacing power transistors and removing PCB are as follows:

CAUTION

Use low power, grounded temperature regulated iron with small tip such as Weller PTA7 and ESD control. Use SN63/37 solder 0.032" diameter with "no clean" flux core, Alpha Metals P2 or equal.

- I) **Replacing power transistors:** Clip all 3 leads near body of transistor. Remove screw and discard device (keep hardware and insulator). Holding each lead in turn with needle nose

pliers, gently heat and remove cut lead from hole in edge or PCB.

Clean insulator and seating area on back of panel. Coat both sides of insulator with silicon (white) thermal compound (unless silicone rubber pads are provided), position it centered on back of device with holes aligned. Insert leads into PCB then place pair over hole in panel; ensure hole in insulator is aligned. Insert screw from far side, pass shoulder bushing over screw and carefully seat shoulder in hole in tab, add flat washer, lock washer and nut (finger tight). Center insulator tighten screw first then solder all three leads in respective slots with full fillet, being careful not to bridge pads. Use ohmmeter to verify there is no short from tab of transistor to panel, or between pads.

CAUTION

Never operate amplifier with load connected when PC assembly is not attached to panel or when any of output transistors is not properly screwed to panel.

After repair, inspect for possible safety hazards, including loose hardware, missing lock washers, correct fuse and lead dress of primary wires (these must be held in position with cable ties so that they cannot touch secondary components). With ohmmeter, check that panel is connected to signal ground.

WARNING

It is essential that the following safety insulation test be performed prior to returning the Power Sub-Woofer to the customer, using one of the following methods.

A) Insulation Resistance Test

With a 500VDC Insulation Tester, Check insulation from the outer metal contact of the RCA jack (chassis) to the line neutral of AC cord. Resistance should be >100MΩ.

B) Hi-Pot Test

If a UL approved Hi-Pot tester is available, test line & neutral of AC cord to outer shell of RCA jack (chassis) at 1100VAC for 2 seconds. Observe all of instrument manufacturer's instructions and safety warnings in performing this test.

Connect sub-woofer system to a music source. Play at high level while checking for air leaks around panel edge,

driver, panel jacks and controls, and voice coil problems such as rubbing or loose turns. With the crossover "frequency" set to 50Hz, very little of the voice content should be heard.

4. LIST OF SAFETY COMPONENTS REQUIRING EXACT REPLACEMENTS

- F1 Fuse SLOW BLO 1A 250v GMC UL approved
- FH Fuse holder. Use only factory replacement
- PWR CORD SPT-2 better with polarized plug, UL appoved wired with the hot side to fused side. Use with UL approved panel strain relief only.
- XF Transformer. Use only factory replacement
- BD1 Bridge diode. Use only factory replacement.
- C36, 37 4700uF, 50V electronic filter caps. Be sure replacement part is at least the same working voltage and capacitance rating. Also the lead spacing is important. Incorrect spacing may cause premature failure due to internal cabinet pressures and vibration.
- K1 Safe operating area relay to protect output devices. Use only factory replacement.
- R64 5.6Ω .5W METAL FILM, non flammable

ARC SUB AMPLIFIER BLOCK DIAGRAM

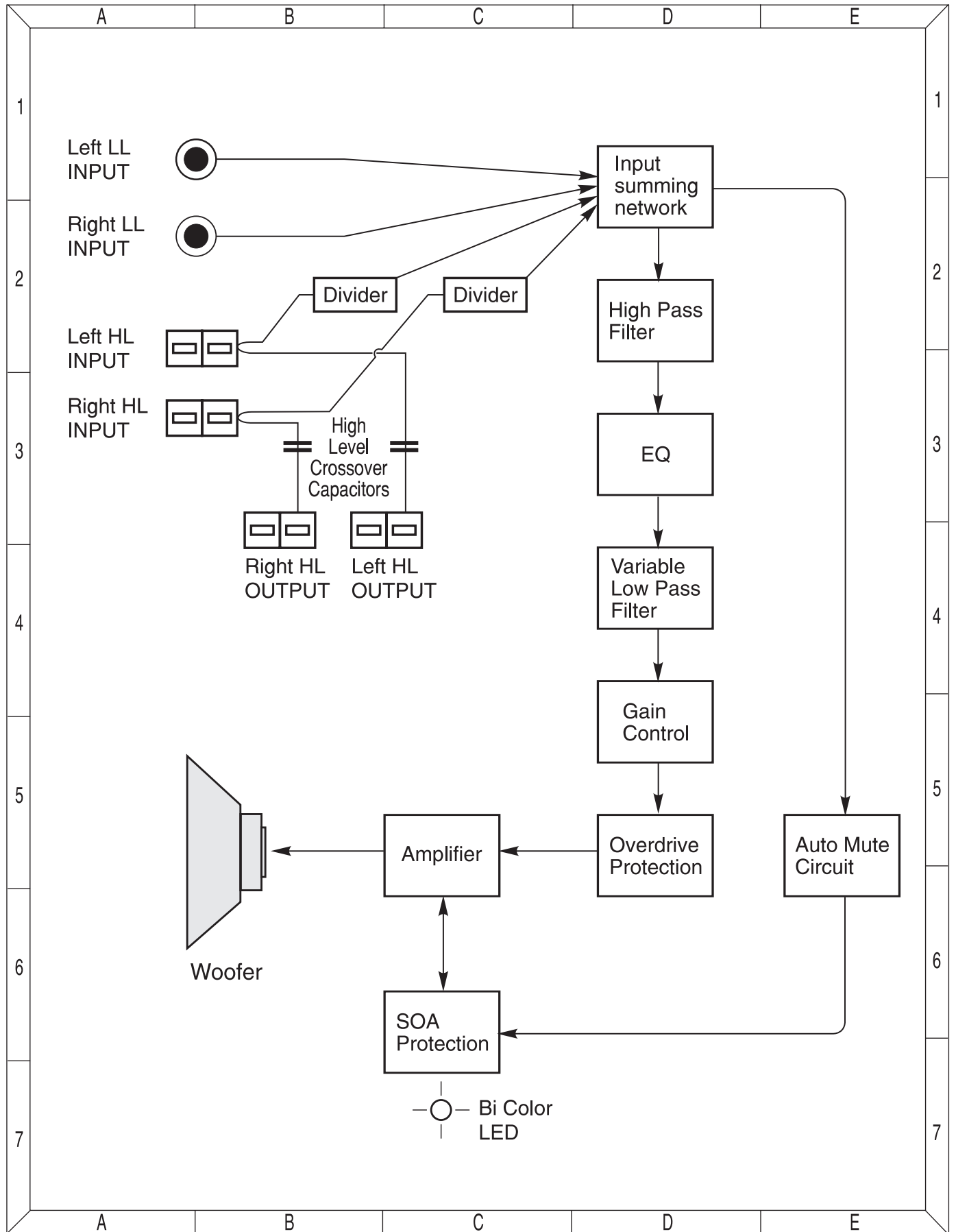

AMPLIFIER EXPLODED VIEW

#	P/N	DESCRIPTION	QTY	#	P/N	DESCRIPTION	QTY
1	NOT SOLD	PRE-AMP PCB ASSY.	1	16	550087300	STRAIN RELIEF	1
2	NOT SOLD	POWER AMP PCB ASSY.	1	17	290205101	"F1" FUSE SLOW-BLO T1.0A 250V	1
3	550101000	HEATSINK	1	18	540083200	"L" BRACKETS	2
4	150226401	TRANSFORMER 8410193F	1	19	560031601	HEATSINK (FOR Q4 & Q5)	2
5	NOT SOLD	PCB INSULATOR FOAM BEZEL	2	20	STPP43007	SELF TAPPING SCREW (H/S Q4 & Q5)	2
6	NOT SOLD	FOAM INSULATOR TAPE for REAR PLATE	N/A	21	SMPP330W6	TAPPING SCREWS	4
7	510112501	FACEPLATE	1	22	S2PP43010	SELF TAPPING SCREW	4
8	260231001	CONN., SPEAKER TERMINALS	2	23	SMPP440W9	MACHINE SCREW	4
9	120215001	CROSSOVER, VR 500KX2	1	24	320008400	O/P TRANSISTOR MICA PAD	2
10	120211501	VOLUME, VR B20KX2	1	25	210213601	POWER CORD	1
11	250213501	LED BRG333B (R/G)	1	26	NM0H54000	NUT	4
12	260231802	CONN. DUAL RCA INPUT	1	27	WS4426600	SPRING WASHER	4
13	SMPP42611	MACHINE SCREW	2	28	WF5411010	FLAT WASHER	4
14	530041500	KNOB	2	29	SMPP440W7	MACHINE SCREW	2
15	260232901	FUSE HOLDER	1				

ARC SUB
Amplifier Exploded View

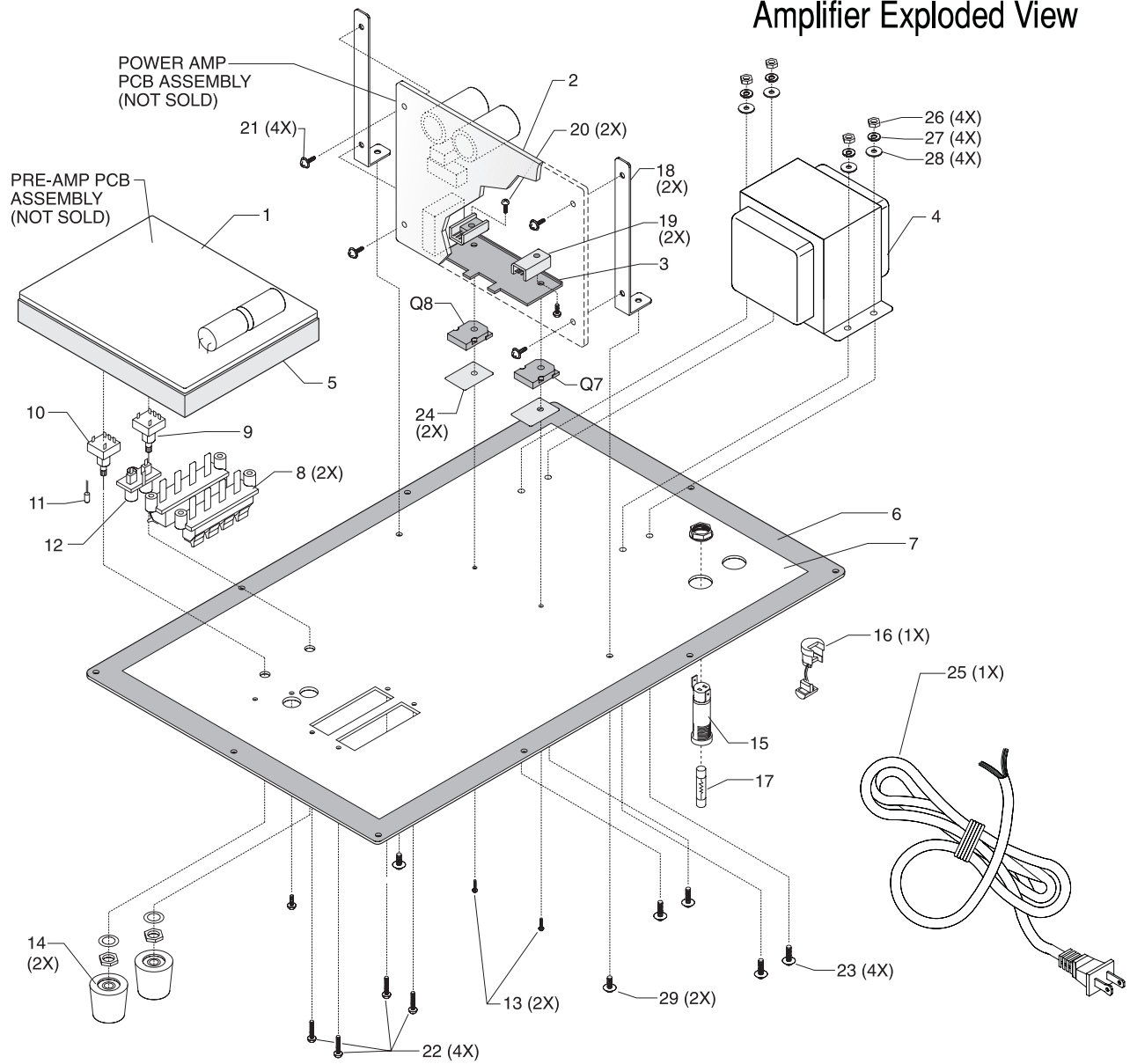

CABINET EXPLODED VIEW

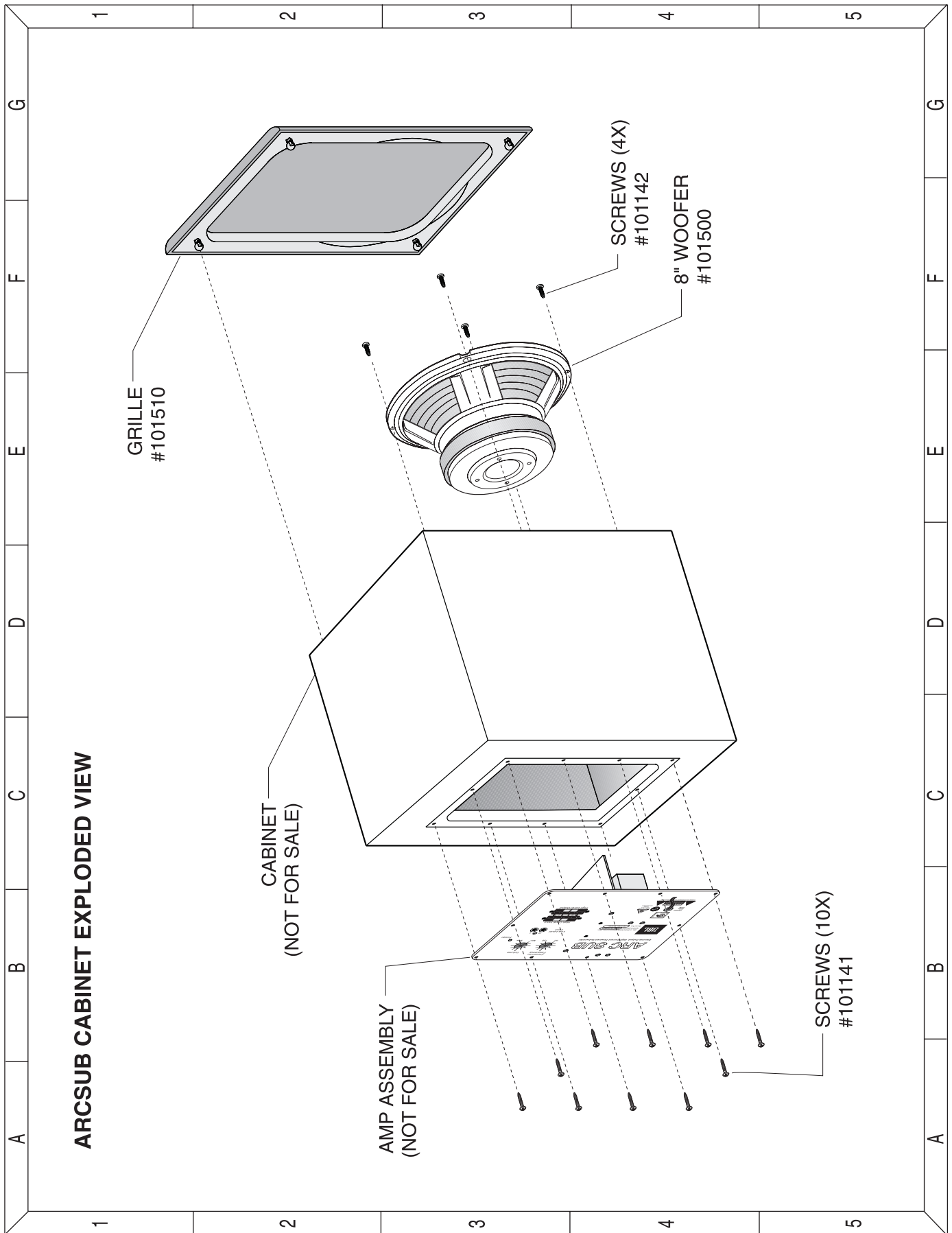

ARC SUB PARTS LISTS

ELECTRICAL PARTS LIST

Ref. Number	Part Number	Description	Quantity
Capacitors			
C1, 2	130001529	100UF 100V NP	2
C3, 4	130000557	4.7UF 16V	2
C5, 6	135100811	100PF CERAMIC	2
C7, 11	130000627	0.015UF 5% MYLAR	2
C8	135020811	20PF CERAMIC	1
C9, 10	130000627	0.015UF MYLAR	2
C12	130048607	0.1UF 16V	1
C13	13000610	0.001UF MYLAR	1
C14	130048604	0.68UF 16V	1
C15	130000620	0.033UF 5% MYLAR	1
C16	130000628	0.0039UF 5% MYLAR	1
C17, 26	130048605	0.33UF 16V	2
C18	130000639	0.0056UF 5% MYLAR	1
C19	130000610	0.001UF 5% MYLAR	1
C20	130000596	0.22UF 16V	1
C21	135470811	470PF CERAMIC	1
C22	130054710	100UF 16V	1
C23	132104652	0.1UF CERAMIC	1
C24	130000551	1000UF 25V	1
C25	130000527	4.7UF 16V	1
C27, 28, 29	130000518	100UF 25V	3
C30	130000622	0.01UF MYLAR 5%	1
C31	130000619	0.047UF MYLAR 5%	1
C32	135022811	22PF CERAMIC	1
C33	130000506	10UF 16V	1
C34, 35	130000549	220UF 25V	2
C36, 37 ▲	130001530	4700UF 50V	2
Resistors			
R1, 2, 3, 4	092101502	100Ω MF 2W	4
R5, 6	084274503	270KΩ CF 1/4W	2
R7, 8	086472502	4.7KΩ CF 1/4W 10MM	2
R9, 10	084473503	47KΩ CF 1/4W 10MM	2
R11, 12	084333503	33KΩ CF 1/4W	2
R13, 14	086473502	47KΩ 1/4W 10MM	2
R15, 16	086102502	1KΩ CF 1/4W 10MM	2
R17, 18	073893582	379KΩ MF 1/16W 1%	2
R19	072325182	23.25KΩ MF 1/16W 1%	1
R20	086625502	2.2MΩ MF 1/4W 10mm	1
R21, 22	079303582	930KΩ MF 1/16W 1%	2
R23	071415282	141.5KΩ MF 1/16W 1%	1
R24	077382582	73.8KΩ MF 1/16W 1%	1
R25	071475282	147.5KΩ MF 1/16W 1%	1
R26	073203582	320KΩ MF 1/16W 1%	1
R27	071603582	160KΩ MF 1/16W 1%	1
R28	073203582	320KΩ MF 1/16W 1%	1
R29, 30, 31, 35, 36, 37	084103503	10KΩ CF 1/4W	6

Ref. Number	Part Number	Description	Quantity
R32	084392503	3.9KΩ CF 1/4W	1
R33	086224502	220KΩ 1/4W 10mm	1
R34	086102502	1KΩ CF 1/4W 10mm	1
R38	084102503	1KΩ CF 1/4W	1
R39	084470503	47Ω CF 1/4W	1
R40	084103503	10KΩ CF 1/4W	1
R41	084275503	2.7MΩ CF 1/4W	1
R42, 43	084332503	3.3KΩ CF 1/4W	2
R44	086752502	7.5KΩ CF 1/4W	1
R45	084104503	100KΩ CF 1/4W	1
R46	084102503	1KΩ CF 1/4W	1
R47, 50	084223503	22KΩ 1/4W	2
R48	084911502	910Ω 1/4W	1
R49, 51	084102503	1KΩ CF 1/4W	2
R52, 53	084392503	3.9KΩ CF 1/4W	2
R54	084272503	2.7KΩ CF 1/4W	2
R55	084182503	1.8KΩ CF 1/4W 10MM	1
R56, 57	091681502	680Ω MF 1W	2
R58, 59	084470503	47Ω CF 1/4W	2
R60, 61	084220503	22Ω CF 1/4W 10MM	2
R62, 63	092158502	0.15Ω MF 2W	2
R64 ▲	095569502	5.6Ω MF 1/2W	1
R65	084104503	100KΩ CF 1/4W	1
R66	084472503	4.7KΩ CF 1/4W 10MM	1
R67	084223503	22KΩ CF 1/4W	1
R68	084561503	560Ω CF 1/4W	1
R69	084153503	15KΩ CF 1/4W	1
R70	084562503	5.6KΩ CF 1/4W 10MM	1
R71	084472503	4.7KΩ CF 1/4W 10MM	1
R72	105681502	680Ω MF 5W	1
R73	092511502	510Ω MF 2W	1
R74	092331502	680Ω MF 2W	1
Diodes			
BD1 ▲	240184801	DIODE BRIDGE RS402L/KBL01	1
D1, 2, 3, 4	240002605	DIODE IN4148	4
ZD1, 2	240224101	ZENER IN5231B	2
ZD3, 4, 5, 6	240221701	ZENER IN4744A 15V 1W	4
ZD7	240094701	ZENER 24V 1/2W	1
Transistors			
Q1	230154501	2SC1815GR	1
Q2	230164501	2SA1015GR	1
Q3	230201201	MPSA06	1
Q4	230175901	2SD1563	1
Q5	230175801	2SB1086-Q	1
Q6	220036001	2SB668-R	1
Q7	230035901	2SD718-R	1
Q8, 10	230154501	2SC1815GR	2
Q9	230164501	2SA1015GR	1
Q11	230078101	2SC2274	1

Ref. Number	Part Number	Description	Quantity
Integrated Circuits			
U1, 2, 3, 4, 5	220214601	IC 4558L DUAL OP AMP	5
U6	220013602	IC 4558D DUAL OP AMP	1
Fuse			
F1 ▲	290205101	FUSE SLOW-BLO T1.0A 250V	1
Miscellaneous			
K1 ▲	200222501	RELAY 24V 6A	1
4 ▲	150226401	TRANSFORMER 8410193F	1
8	260231001	CONNECTOR SPEAKER TERMINALS	2
VR1	120215401	VR1 500K x 2 Frequency	1
VR2	120211501	VR2 20K X 2 Volume	1
LED1	250213501	LED BRG333B(R/G)	1
12	260231802	CONN DUAL RCA INPUT	1
15 ▲	260232901	FUSE HOLDER	1
25 ▲	210213601	POWER CORD	1

Ref. Number	Part Number	Description	Quantity
-------------	-------------	-------------	----------

PACKAGING PARTS LIST

101125	STYROCORNERS	8
101540	POLY BAG	1
101520	BEAUTY CARTON	1
76082	WARRANTY CARD	1
101530	SET-UP GUIDE	1
101145	BOTTOM PADS	1

NOTE: This caution sign ▲ is found by components in which safety can be of special significance. When replacing a component identified with the ▲ sign replace only with same rating

MECHANICAL PARTS LIST

Ref. Number	Part Number	Description	Quantity
1	NOT SOLD	PRE-AMP PCB ASSY.	1
2	NOT SOLD	POWER AMP PCB ASSY.	1
3	550101000	HEATSINK	1
5	NOT SOLD	PCB INSULATOR FOAM BEZEL	1
6	NOT SOLD	FOAM INSULATION TAPE	1
7	510112501	FACEPLATE	1
14	530041500	KNOB	2
16	550087300	STRAIN RELIEF	1
18	540083200	"L" BRACKETS	2
19	560031601	HEATSINK FOR Q4 & Q5	2
20	STPP43007	SELF TAPPING SCREW	2
21	SMPP330W6	TAPPING SCREWS	4
22	S2PP43010	SELF TAPPING SCREWS	4
23	SMPP440W9	MACHINE SCREW	4
24	320008400	O/P TRANSISTOR MICA PAD	2
26	NH0H54000	NUT	4
27	WS4426600	SPRING WASHER	4
28	WF5411010	FLAT WASHER	4
29	SMPP440W7	MACHINE SCREW	2
	101510	GRILLE	1
	101142	SCREWS (FOR WOOFER)	4
	101500	8" WOOFER	1
	101141	SCREWS (FOR REAR PLATE)	10

PACKAGING EXPLODED VIEW

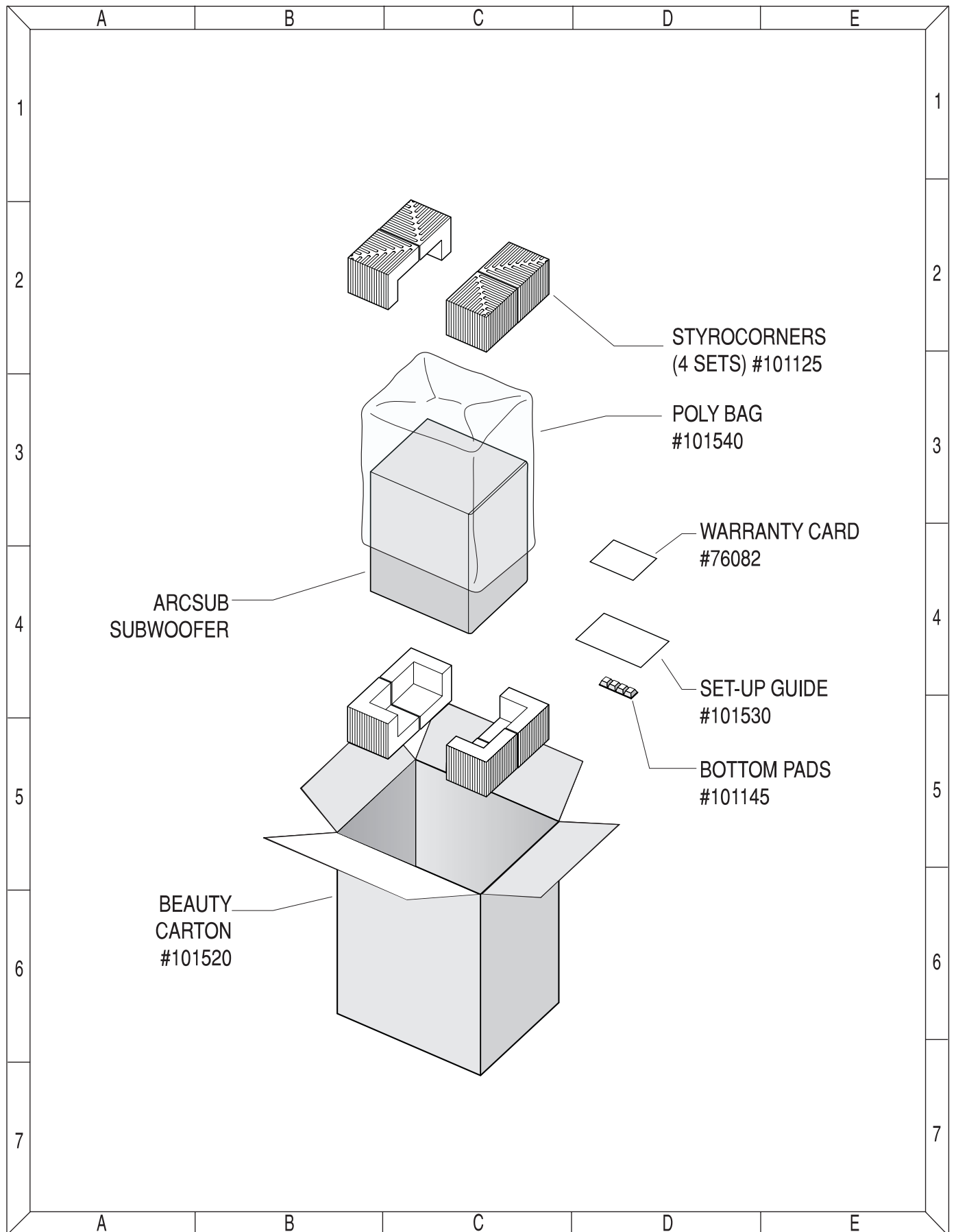

INTEGRATE CIRCUIT DIAGRAMS

U1, 2, 3, 4, 5 - 220214601 (4558L)
Dual Op Amp (side view)

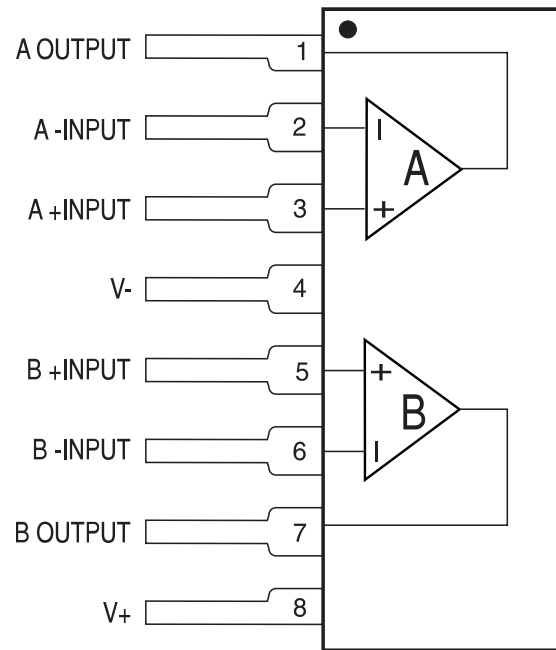

U6 - 220013602 (4558D) Dual Op Amp
Dual In-Line Package (top view)

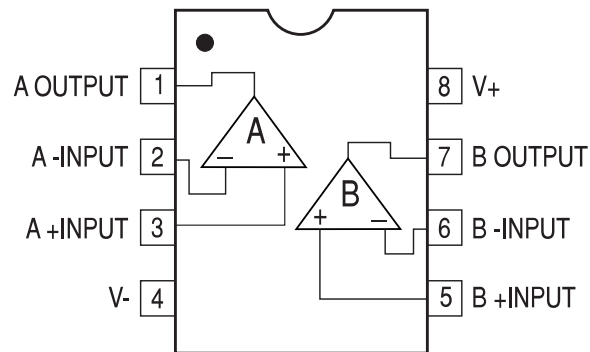

PREAMP PRINTED CIRCUIT BOARD (TOP VIEW)

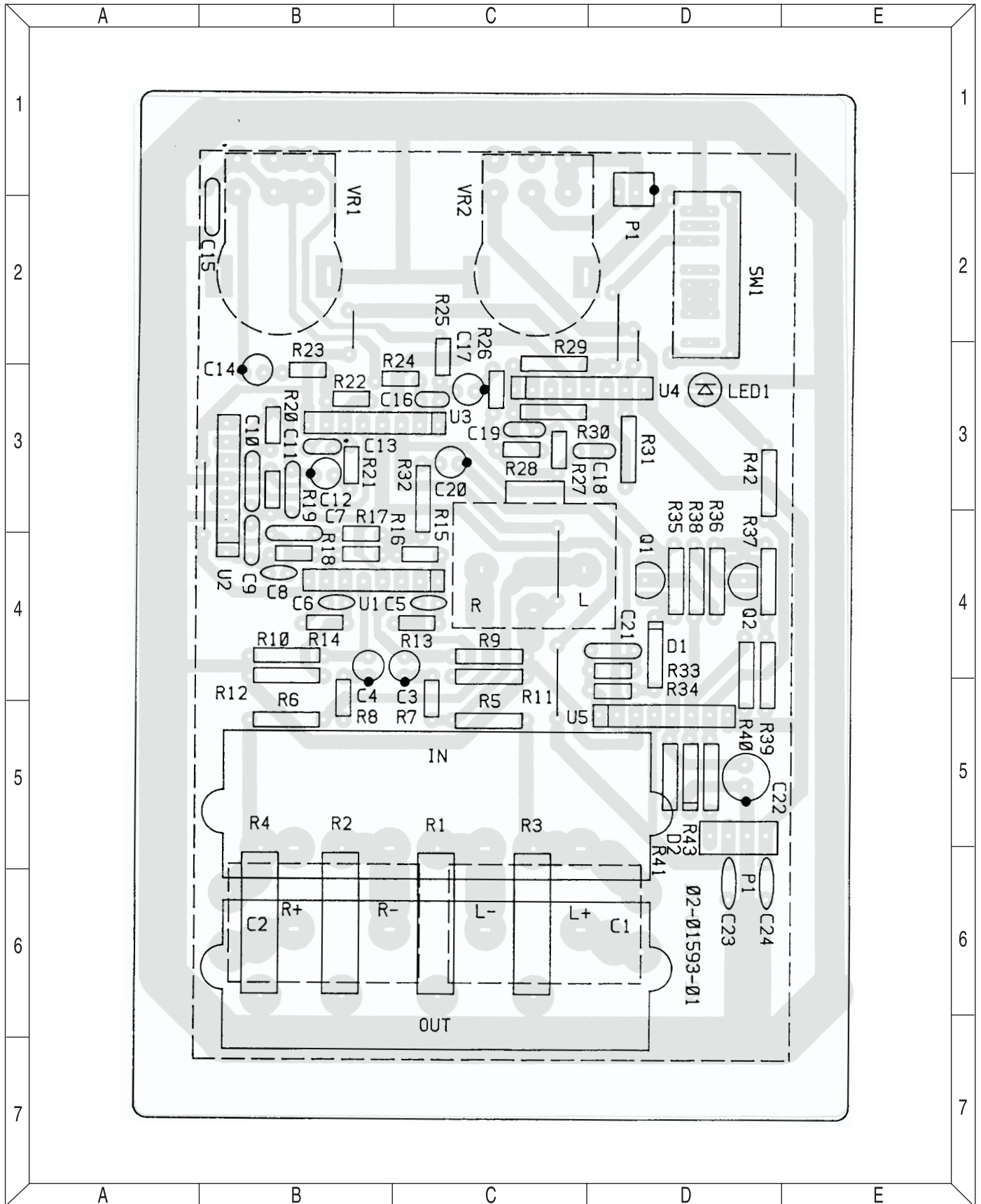

POWER AMP PRINTED CIRCUIT BOARD (TOP VIEW)

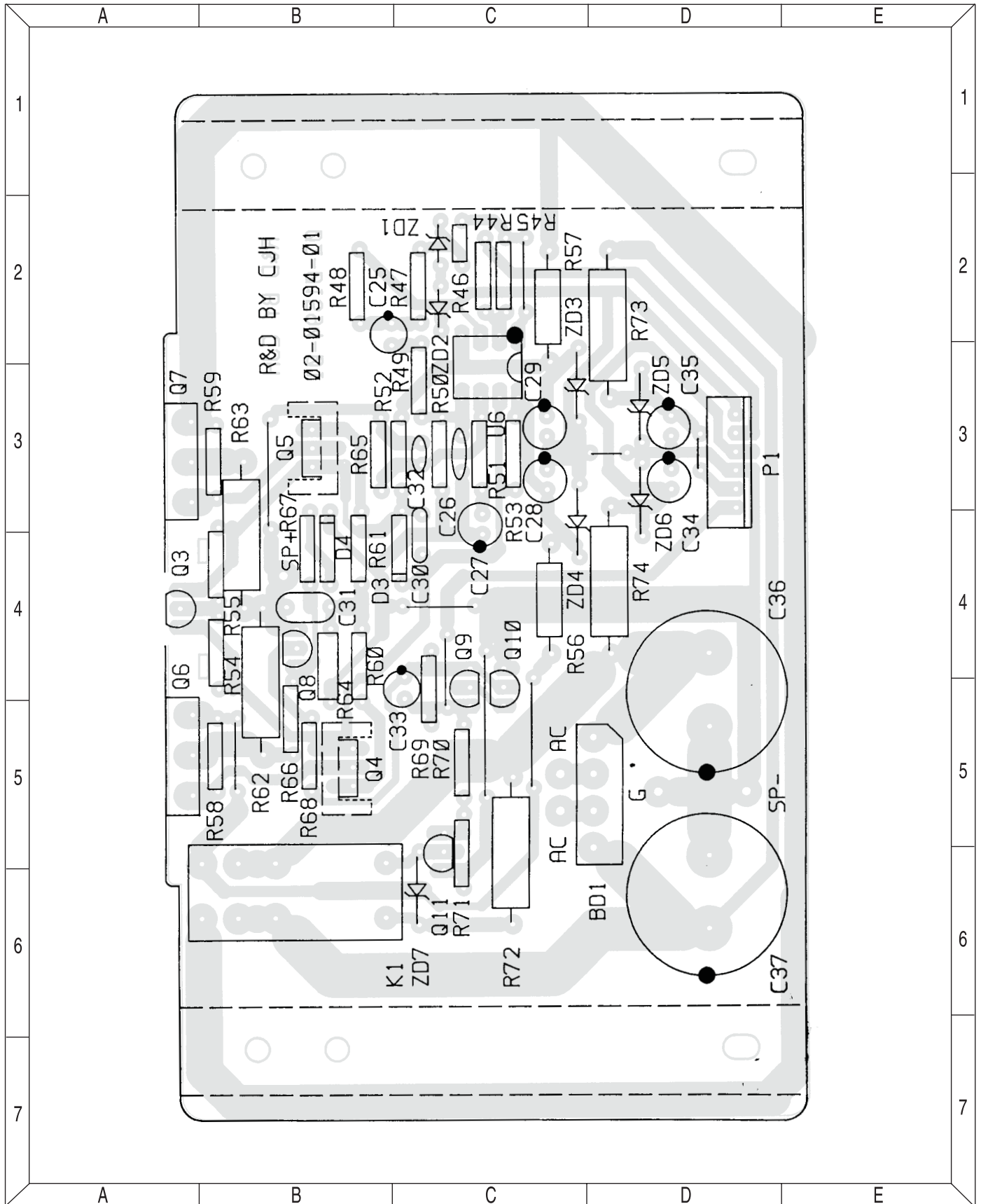

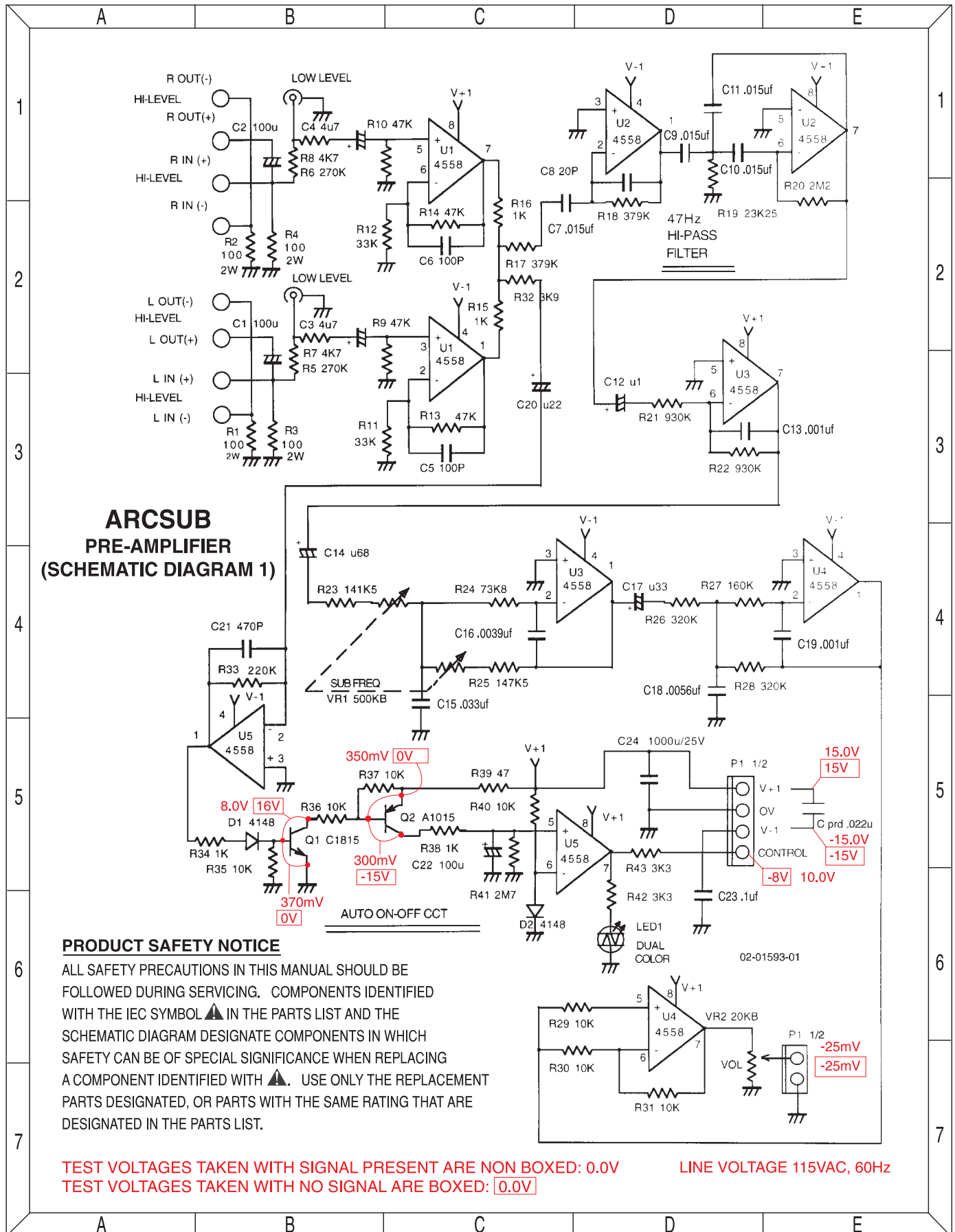

SCHEMATIC DIAGRAM 1



**ARCSUB
PRE-AMPLIFIER
(SCHEMATIC DIAGRAM 1)**

PRODUCT SAFETY NOTICE

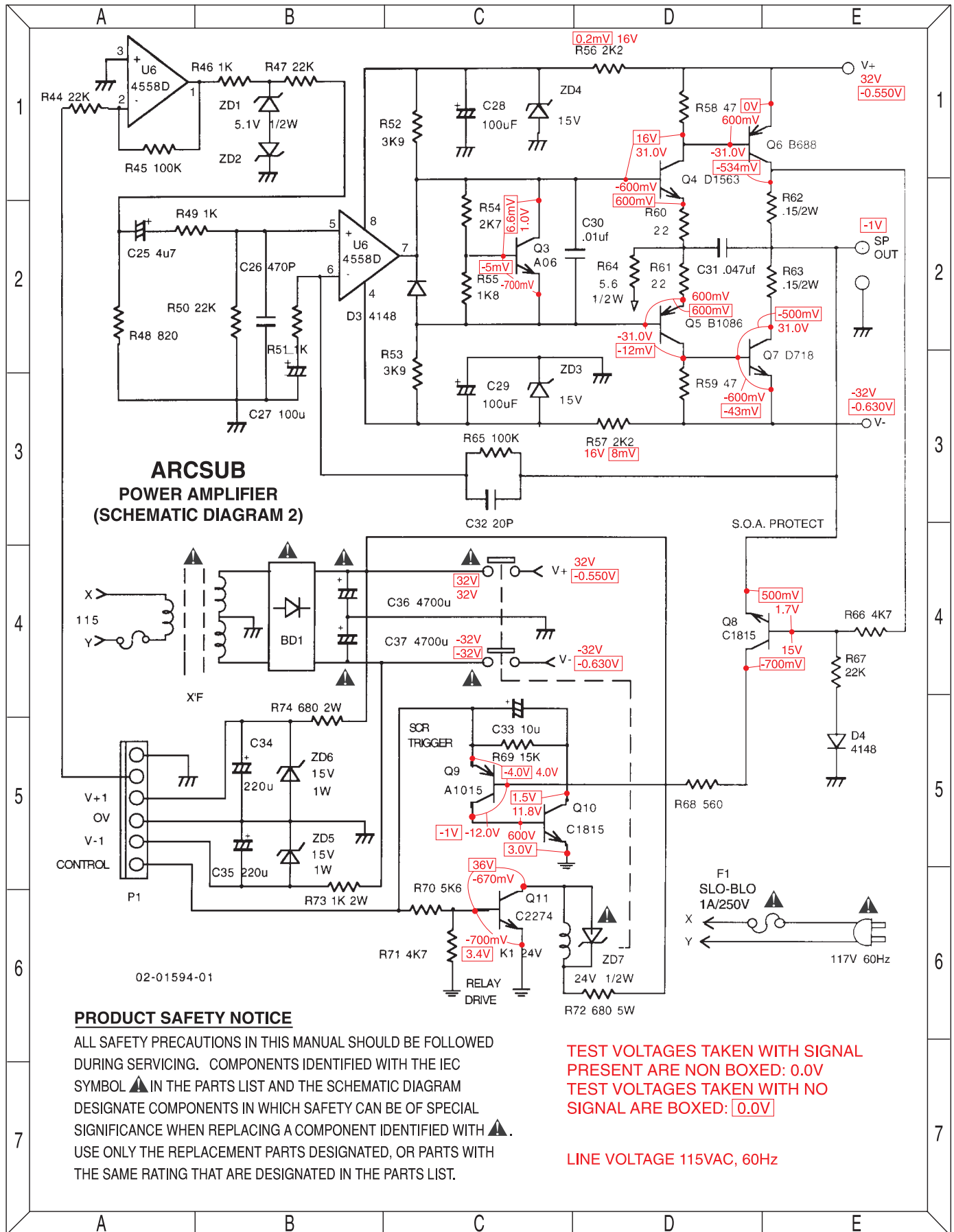

ALL SAFETY PRECAUTIONS IN THIS MANUAL SHOULD BE FOLLOWED DURING SERVICING. COMPONENTS IDENTIFIED WITH THE IEC SYMBOL  IN THE PARTS LIST AND THE SCHEMATIC DIAGRAM DESIGNATE COMPONENTS IN WHICH SAFETY CAN BE OF SPECIAL SIGNIFICANCE WHEN REPLACING A COMPONENT IDENTIFIED WITH . USE ONLY THE REPLACEMENT PARTS DESIGNATED, OR PARTS WITH THE SAME RATING THAT ARE DESIGNATED IN THE PARTS LIST.

SCHEMATIC DIAGRAM 2



**ARCSUB
POWER AMPLIFIER
(SCHEMATIC DIAGRAM 2)**

PRODUCT SAFETY NOTICE

ALL SAFETY PRECAUTIONS IN THIS MANUAL SHOULD BE FOLLOWED DURING SERVICING. COMPONENTS IDENTIFIED WITH THE IEC SYMBOL  IN THE PARTS LIST AND THE SCHEMATIC DIAGRAM DESIGNATE COMPONENTS IN WHICH SAFETY CAN BE OF SPECIAL SIGNIFICANCE WHEN REPLACING A COMPONENT IDENTIFIED WITH . USE ONLY THE REPLACEMENT PARTS DESIGNATED, OR PARTS WITH THE SAME RATING THAT ARE DESIGNATED IN THE PARTS LIST.

TEST VOLTAGES TAKEN WITH SIGNAL PRESENT ARE NON BOXED: 0.0V
TEST VOLTAGES TAKEN WITH NO SIGNAL ARE BOXED: [0.0V]

LINE VOLTAGE 115VAC, 60Hz