



BASS 2/BASSWAVE

SPECIFICATIONS

ACOUSTIC & ELECTRICAL SPECIFICATIONS:

- Nominal Impedance: 4 ohm
- Amplifier Power: 100W Continuous
- Frequency Response: 40 Hz to 120 Hz (± 3 dB)
- Sensitivity: 90 dB SPL*
- Crossover Frequency: 120 Hz (Nominal)
- Amplifier Input Impedance: 48k ohm (Line) / 1k ohm (Speaker)

SYSTEM COMPONENTS:

- Cabinet: CBass2/BassWave (Not For Sale)
- Grille: N/A
- Low Frequency Transducer: SE5H 5-1/4 in. (130mm) (75089-01) (2)
SE5HS 5-1/4 In. (130mm) (75089) (2)
- DC Resistance: 5.0 ohm $\pm 5\%$
- Crossover Network: N/A

SYSTEM COMPONENTS: (cont'd)

AURAL SWEEP TEST SPECIFICATIONS:

- A. System Aural Sweep Test: 5.0V Input, 10 Hz to 1 kHz
- B. L.F. Aural Sweep Test: 5.0V Input, 10 Hz to 1 kHz

PHYSICAL SPECIFICATIONS:

- Enclosure Dimensions: 28.17 x 10.25 x 12.05 in. D
(With Base) (716mm x 260mm x 306mm D)
- Shipping Weight: 32 lbs. (14.5 kg.)

WARRANTY INFORMATION:

- Refer to the Warranty Statement packed with each product.

*1 Watt @ 1 Meter

PACKAGE

Warranty 76310
Owner's Manual 76309-07

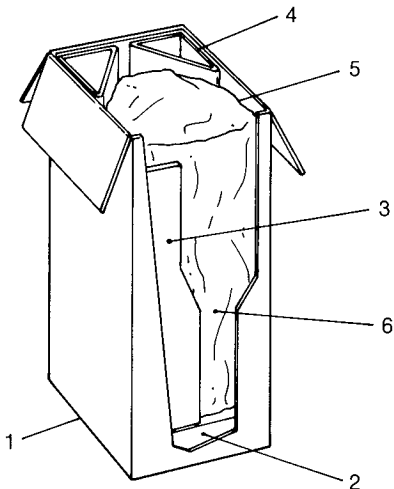

- 1 Carton, 75831
- 2 End Pad (2), 75832
- 3 Filler, 76057
- 4 Filler, Corrugated (2), 76363
- 5 Installation Kit, 76217-02
- 6 Polybag, 64222

NOTE: THE BASS 2/BASSWAVE IS PART OF THE SOUND EFFECTS MUSIC 2 SPEAKER SYSTEM.

WIRING DIAGRAM

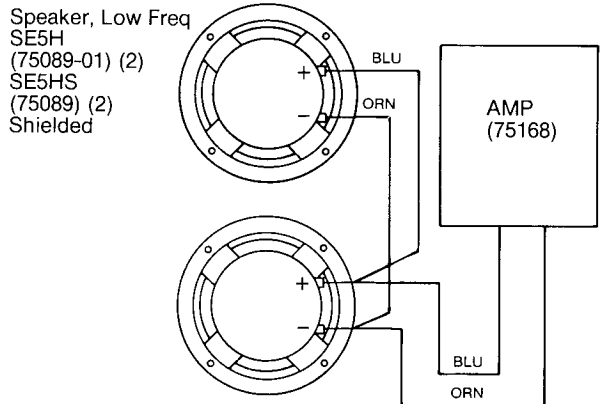

SCHEMATIC

(Not Applicable)

- NOTE:
- UPPER DRIVER IS NON SERVICEABLE. ORDER REPLACEMENT CABINET/DRIVER ASSY P/N BASSWAVEENCLKIT.
 - BASSWAVE/BASS 2 AMP MODULE SHOULD ONLY BE SERVICED BY JBL CONSUMER SERVICE CENTERS WHO ARE FRANCHISED FOR ELECTRONIC REPAIRS.
 - USE NEW GASKET BETWEEN AMP/ENCLOSURE WHEN REASSEMBLING BASSWAVE/BASS 2 TO ENSURE AIRTIGHT SEAL.
 - CUSTOMERS WHO OWN BASSWAVES WITH S/N PREFIX "JSE KA" MAY COMPLAIN OF PORT NOISE/POPPING AT MODERATE LEVELS. IF THE DRIVERS ARE FUNCTIONING PROPERLY (SEE AURAL SWEEP TEST SPECIFICATIONS), AND THE UNIT SUFFERS FROM THIS PROBLEM, PLEASE CONTACT JBL TO ARRANGE FACTORY SERVICE.
 - CUSTOMERS WHO OWN BASSWAVES WITH S/N PREFIX "JSE KA" OR "JSE KD" MAY COMPLAIN OF A LOW LEVEL DISTORTION WHICH IS HEARD ONLY DURING VERY QUIET MUSICAL PASSAGES. PLEASE REFER TO AMP MODULE SERVICE MANUAL FOR FURTHER INFORMATION REGARDING THIS PROBLEM.

NOTE: CONE/DIAPHRAGM KIT NOT AVAILABLE. DEFECTIVE SPEAKER SHOULD BE REPLACED.

BASS 2/BASSWAVE

BASS 2/BASSWAVE

COMPONENT EXPLODED VIEW

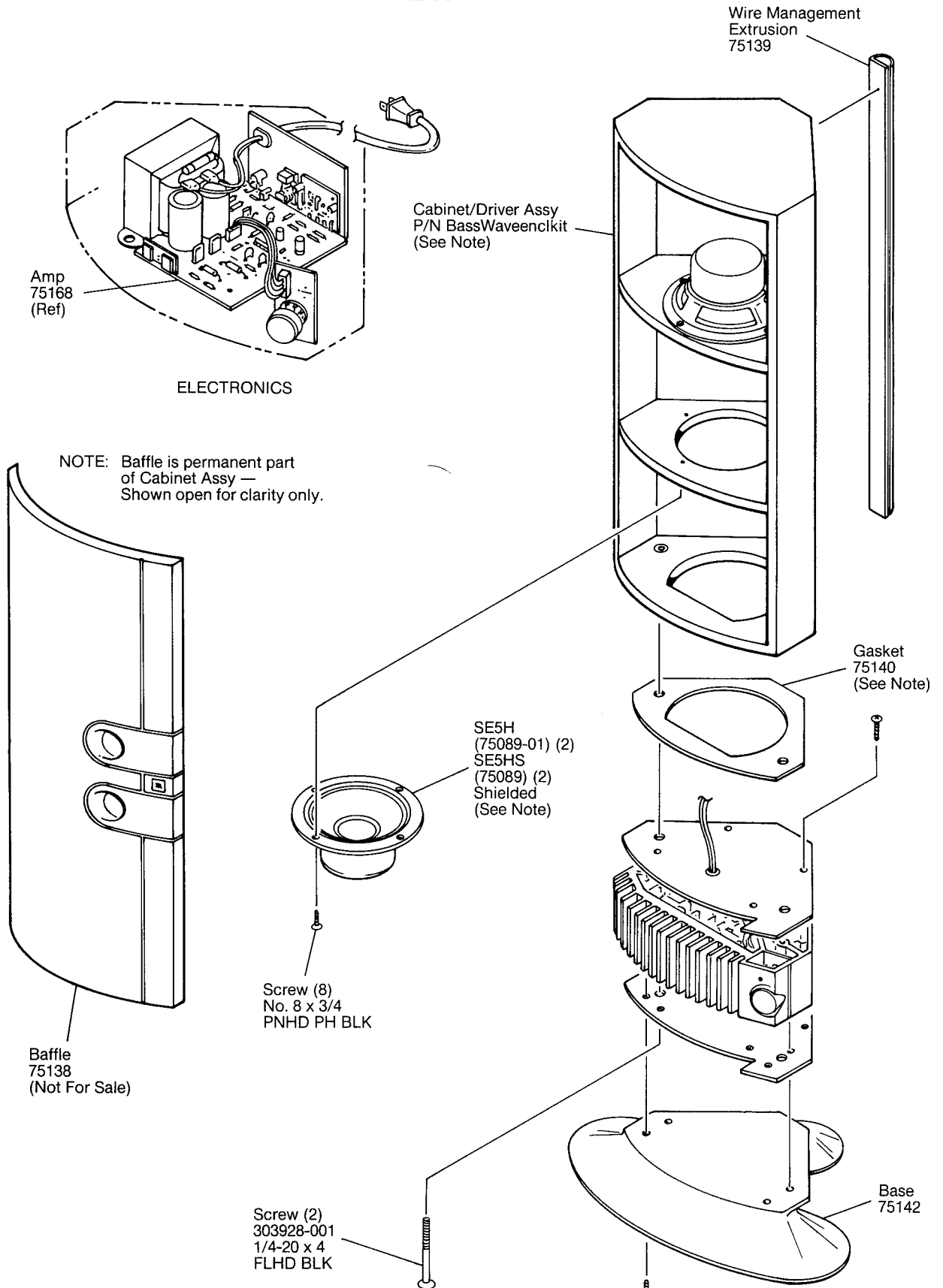

NOTE: USE NEW GASKET TO ENSURE AIRTIGHT SEAL WHEN SERVICING SPEAKER/AMP.

BASS 2/BASSWAVE