

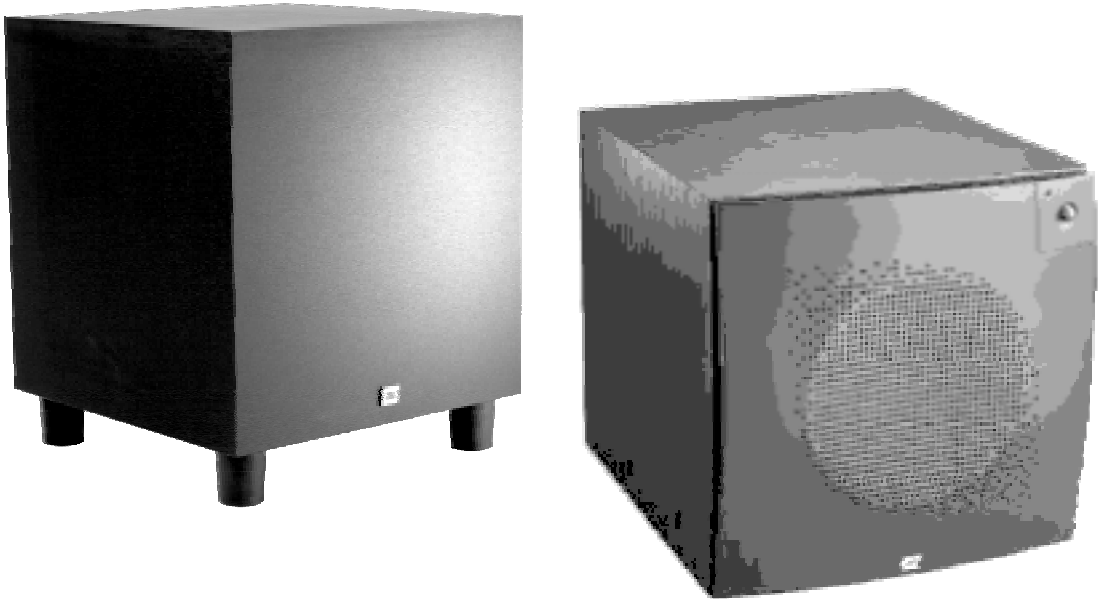

PSW-D110/DPS-10

Powered Subwoofer

SERVICE MANUAL



JBL Consumer Products Inc.
250 Crossways Park Drive
Woodbury, N.Y. 11797
1-800-336-4JBL in the USA

H A Harman International Company

Rev C 8/2000

SAFETY INFORMATION

Warning

Any person performing service of this unit will be exposed to hazardous voltages and the risk of electric shock. It is assumed that any person who removes the amplifier from this cabinet has been properly trained in protecting against avoidable injury and shock. Therefore, any service procedures are to be performed by qualified service personal ONLY!

Caution

This unit does not have a power switch. Hazardous voltages are present within the unit whenever it is plugged in.

Before the amplifier is plugged in, be sure its rated voltage corresponds to the voltage of the AC power source to be used. Incorrect voltage could cause damage to the amplifier when the AC power cord is plugged in. Do not exceed rated voltage by more than 10%: operation below 90% of rated voltage will cause poor performance or may shut the unit off.

Leakage/Resistance Check

Before returning the unit to the customer, perform a leakage or resistance test as follows:

Leakage Current. Note there is no power switch on this unit. When the power plug is plugged in, the unit is live. Connect the unit to its rated power source. Using an ammeter, measure the current between the neutral side of the AC supply and chassis ground of the unit under test. If leakage current exceeds 0.5mA, the unit is defective. Reverse the polarity of the AC supply and repeat.

Resistance. Measure the resistance from either side of the line cord to chassis ground. If it is less than 500k ohms, the unit is defective.

WARNING! DO NOT return the unit to the customer if it fails one of these tests until the problem is located and corrected.

Critical Components



All components identified with the IEC symbol in the parts list and the schematic diagram designate components in which safety can be of special significance when replacing a component identified with . Use only the replacement parts designated in the parts list or parts with the same rating of resistance, wattage or voltage.

List of Safety Components Requiring Exact Replacements

F1	Fuse SLO BLO 1.25A 250V UL approved
PWRCORD	SPT-2 or better with polarized plug, UL approved wired with the hot side to fused side. Use with factory replacement panel strain relief only.
TRX1	Transformer. Use only factory replacement.
DBR	Bridge diode. Use only factory replacement.
C1, 2	4700uF, 50V electrolytic filter caps. Be sure replacement part is at least the same working voltage and capacitance rating. Also the lead spacing is important. Incorrect spacing may cause premature failure due to internal cabinet pressure and vibration.
C6	10uF 50V electrolytic radial See Page 14 Service Bulletin
S52AMI	Power output module. Use only factory replacement
Faceplate	Faceplate. Use only factory replacement
Air leak cover	Use only factory replacement
CMC1	Use only factory replacement
L1	Use only factory replacement
Fuse PCB	Use only factory replacement
Main PCB	Use only factory replacement

TABLE OF CONTENTS

SAFETY INFORMATION.....2	CABINET EXPLODED VIEWS17
TABLE OF CONTENTS.....3	AMPLIFIER EXPLODED VIEW18
GENERAL SPECIFICATIONS3	PSW-D110/DPS-10 MECHANICAL PARTS LIST.....19
DETAILED SPECIFICATIONS.....4	PACKING EXPLODED VIEWS.....20
PSW-D110/DPS-10 CONTROLS AND THEIR FUNCTION.....6	PSW-D110/DPS-10 Version 3.53 PCB (Component Side)21
OPERATION.....7	PSW-D110/DPS-10 Version 3.53 PCB (Solder Side)22
SPEAKER CONNECTIONS.....8	PSW-D110/DPS-10 Version 3.93 PCB (Component Side)23
TROUBLESHOOTING9	PSW-D110/DPS-10 Version 3.93 PCB (Solder Side)24
PSW-D110/DPS-10 TEST SET UP AND PROCEDURE.....10	PSW-D110/DPS-10 ELECTRICAL PARTS LIST25
PSW-D110/DPS-10 POWER AMP TEST PROCEDURE and FLOW CHART.....11	PSW-D110/DPS-10 INTEGRATED CIRCUITS26
SERVICE BULLETIN JBL9902 REV1 - MAY 199914	PWS-D110/DPS-10 SCHEMATIC 1 of 2.....27
SERVICE BULLETIN JBL9903 - APRIL 199915	PWS-D110/DPS-10 SCHEMATIC 2 of 2.....28
SERVICE BULLETIN JBL2000-01 - JANUARY 2000.....16	

GENERAL SPECIFICATIONS

Amplifier Power (RMS).	150 watts	
Driver 10"	High-Polymer Laminate	
Inputs	Line Level and Speaker Level	
Outputs	Line Level and Speaker Level	
Low-Pass Frequency	Continuously variable from 60Hz – 180Hz	
High-Pass Frequency	Continuously variable from 60Hz – 180Hz when using line-level inputs 180Hz when using speaker-level inputs	
Frequency Response	30Hz – low-pass crossover setting	
	PSW-D110	DPS10
Dimensions (H x W x D)	15-3/8 x 15-3/8 x 17" (391 x 391 x 432mm)	18-1/16 x 14-7/8 x 15-7/8" (459 x 378 x 403mm)
Weight	33 lbs/15 kg	30 lbs/13.6 kg

DETAILED SPECIFICATIONS

LINE VOLTAGE	Yes/No	Hi/Lo Line	Unit	Notes
US 120vac/60Hz	Yes	108-132	Vrms	Normal Operation
EU 230vac/50-60Hz	Yes	207-264	Vrms	Normal operation, MOMS required
Parameter	Specification	Unit	Conditions	Notes
Amp Section				
Type (Class AB, D, other)	D			Class D Preferred...Sink required for Class AB
Load Impedance (speaker)	4	Ohms	Nominal	Z-curve required
Rated Output Power	150	Watts	1 input driven	Peak power
	75	Watts	1 input driven	RMS
THD@ Rated Power	0.1	%	22k filter	75w (Power Bandwidth 30-100Hz)
THD @ 1 Watt	0.1	%	22k filter	
DC Offset	2	mV-DC	@ Speaker Outputs	
Damping factor	>200	DF		
Input Sensitivity				
Input Frequency	50	Hz	Nominal Freq.	1 input driven
Line Input	110	mVrms	To Rated Power/ Vol @ Max	1 input driven
Speaker/Hi Level Input	2.7	Vrms	To Rated Power/ Vol @ Max	1 input driven: AP source Z = 25 ohms
Signal to Noise				
SNR-A-Weighted	100	dBA	relative to 75w power	A-Weighting filter
SNR-unweighted	75	dBr	relative to 75w power	22k filter
SNR rel. 1W-unweighted	65	dBr	relative to 1W Output	22k filter
Residual Noise Floor	2	mVrms	Volume @max, using RMS reading DMM/VOM (or A/P)	
Residual Noise Floor	1.5	mVrms(max)	Volume @max, w/ A/P Swept Bandpass Measurement (Line freq.+ harmonics)	
Input Impedance				
Line Input	10k	ohms	Nominal	
Speaker/Hi Level Input	200	ohms	Nominal	
Filters				
Low Pass (fixed or variable)	Variable			0dBr = 1w @ 50Hz
Low Pass filter (point or range)	60-120	Hz	-3dB Point	
Slope	18	dB/Octave		
Q	1	Damping		
Subsonic filter (HPF)	25	Hz	-3dB Point	
Slope	12	dB/Octave		
Q	1	Damping		

Limiter (yes/no)	Yes			
THD at Max. Output Power	10	%	Maximum Output Power	Maximum THD as a result of limiting.
Features				
Phase Switch (yes/no)	yes	—		
Volume pot Taper (lin/log)	linear	—		
Input Configuration				
Line In (L,C,R,AC3,Mono)	L,R	—	Enabled w/Line/Spkr Input Select Switch	
Line Outputs (L,C,R)	L,R	—		Buffered Output / Pre-Volume control
Line-Out Adj. X-over	130-240	Hz	Var-HPF (Pot CCW and CW positions)	Rear panel Variable xover
Spkr/Hi Level In (L,C,R,mono)	L,R	—	Enabled w/Line/Spkr Input Select Switch	
Spkr Out: Hi Pass Filter	100	Hz	8 ohm Satellite: 6dB/oct passive xover	Driven from zero ohms source impedance
Signal-Present LED				
Signal-Present Input Freq.	100	Hz	Nominal	200uF Series Cap on PCB
Signal-Present Level	2	mV	100Hz into Line Input w/ 1 ch. driven	
Signal-Present Bandwidth	1k	Hz	Signal-Present-LPF for noise immunity	
Signal-Present Turn-on time	1	sec.	Amp connected and AC on, then input signal applied	
Auto Mute/ Turn-OFF Time	15	min.	T before muting, after signal is removed	
Power on Delay time				
Power on Delay time	3	sec.	AC Power Applied	
Transients/Pops				
Signal-Present Transient	5	mV-peak	@ Speaker Outputs	
Turn-on Transient	500	mV-peak	@ Speaker Outputs	AC Line cycled from OFF to ON
Turn-off Transient	500	mV-peak	@ Speaker Outputs	AC Line cycled from ON to OFF
Efficiency				
Stand-by Input Power	17	Watts	@ nom. line voltage	
AC Power Cons.@1W	18	Watts	@ nom. line voltage	
Power Cons.@rated power	107	Watts	@ nom. line voltage	
Efficiency	70.09%	%	Relative to 75w output	
Protection				
Short Circuit Protection	yes		Direct short at output	
Line Fuse Rating	1.25	Amps	Type-T or Slo Blo	

PSW-D110/DPS-10 CONTROLS AND THEIR FUNCTION

1. Power - (PSW-D110 ONLY) This light will be RED when the unit is plugged in and not receiving a signal; when the PSW-D110 receives a signal, the light will cycle to GREEN. If no signal is received after 10 – 15 minutes the light will cycle back to RED (standby) until a signal is present again.

2. Level Control - The subwoofer Level Control, (PSW-D110, located on the front panel, DPS-10, on the rear panel) adjusts the volume of the subwoofer relative to the rest of the system.

3. High Pass Control - Controls the the roll-off point of the highest frequency the subwoofer will produce.

4. Phase Switch - Changes the subwoofer's output to be in phase or 180 degrees out of phase with the program material.

5. Low Pass Control - Controls the roll-off point of the lowest frequency produced at the High Pass Output Jacks.

6. High Pass Output - When using the Line-Level Input jacks, these are connected to an external power amplifier or receiver to power the main loudspeakers with a high pass filter if desired.

7. Line Input - Main Input connection to subwoofer (preferred).

8. Speaker In Jacks - Main Input connection to subwoofer when line level, subwoofer, or pre-amp output connectors are not available, or when a high pass filter (set at 180Hz) to main loudspeakers is desired through the Speaker Output Jacks.

9. Speaker Out Jacks - Connected to main loudspeakers when the Speaker Input Jacks are used.

Front Panel (PSW-D110 only)

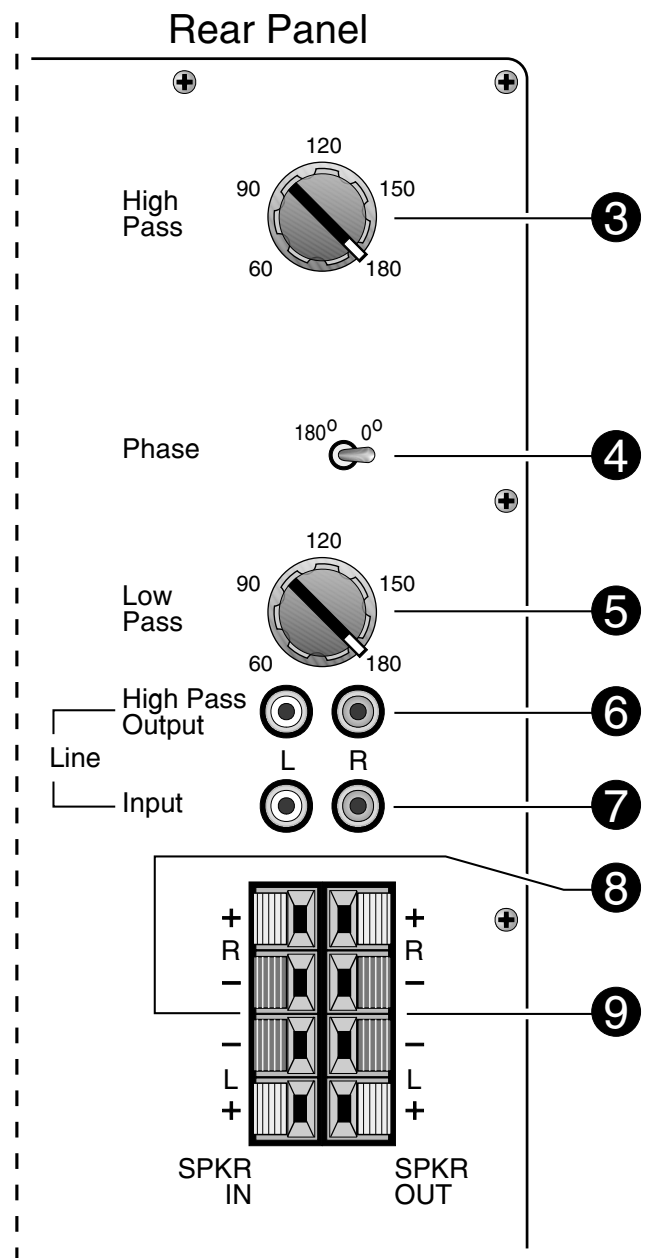
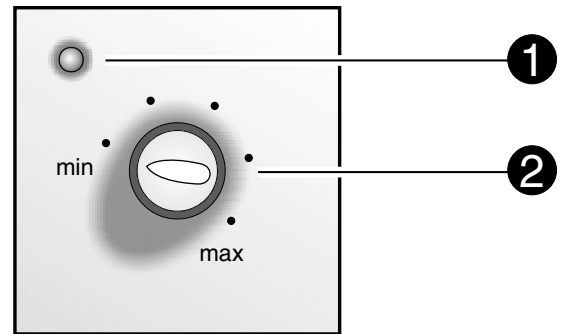

OPERATION

Crossover Adjustments

High-Pass Control

• This control is only active if you are using the hook-up method described in detail on page 8, Figure 3. The High-Pass control determines the frequency at which the main speakers will start reproducing sounds. If your main speakers can comfortably reproduce some low-frequency sounds, also set this control to a lower frequency setting, between 50Hz – 100Hz. This will concentrate the subwoofer's efforts to the ultradeep bass sounds, while your main speakers continue to reproduce the mid-bass information. If you are using smaller bookshelf speakers that do not extend to the lower bass frequencies, set the high-pass crossover control to a higher setting, between 125Hz – 180Hz. With this setting, your main speakers will not have the burden of reproducing any low-frequency sounds.

Final adjustment and blending of the low-pass and high-pass controls may evolve over several listening sessions. A good starting point would be to set both the low- and high-pass controls to the same frequency and adjust from that point.

Low-Pass Control

The Low-Pass control determines the highest frequency at which the subwoofer reproduces sounds. If your main speakers can comfortably reproduce some low-frequency sounds, set this control to a lower frequency setting, between 50Hz – 100Hz. This will concentrate the subwoofer's efforts on the ultradeep bass sounds required by today's films and music. If you are using smaller bookshelf speakers that do not extend to the lower bass frequencies, set the low-pass crossover control to a higher setting, between 120Hz – 180Hz.

Phase

Phase Control

The Phase Control determines whether the subwoofer speaker's piston-like action moves in and out with the main speakers, 0°, or opposite the main speakers, 180°. There is no correct or incorrect setting. Proper phase adjustment depends on several variables such as room size, subwoofer placement and listener position. Adjust the phase switch to maximize bass output at the listening position.

Remember, every system, room and listener is different. There are no right or wrong settings; any setting you choose will result in excellent performance. Should you decide to fine-tune your system for optimum performance, be patient and trust your ears. It will be worth the effort involved to fully "tweak" your system.

SPEAKER CONNECTIONS

NOTE: The rear plate for the PSW-D110 is shown, which has the level control on the front panel. The DPS-10 has this level control on the rear panel (amplifier)

Figure 1

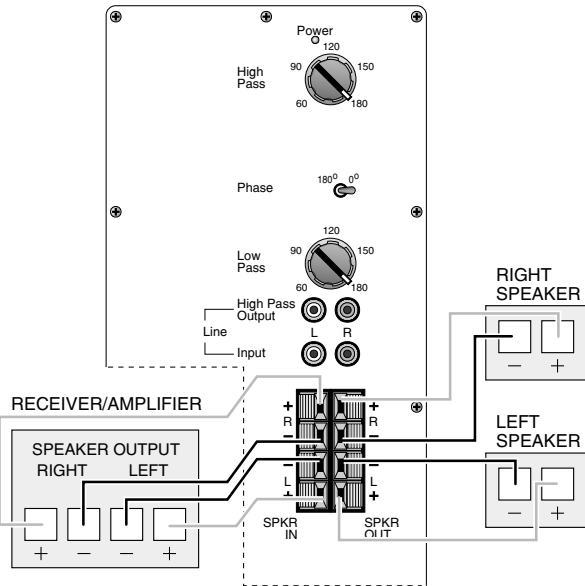

1) If your receiver/amplifier has no subwoofer outputs or preamp outputs for the left and right channels. See Figure 1.

2) If your receiver/amplifier has subwoofer outputs or preamp output jacks for the left and right channels. See Figure 2.

Note: Some receivers/amplifiers have a single (mono) subwoofer output. In this case, it is recommended that you use a "Y"-connector (not included) to maximize the subwoofer's performance.

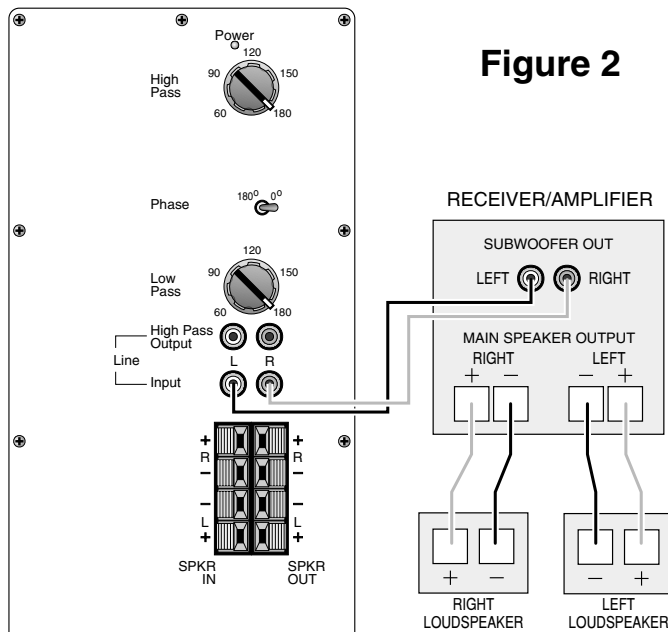

Figure 2

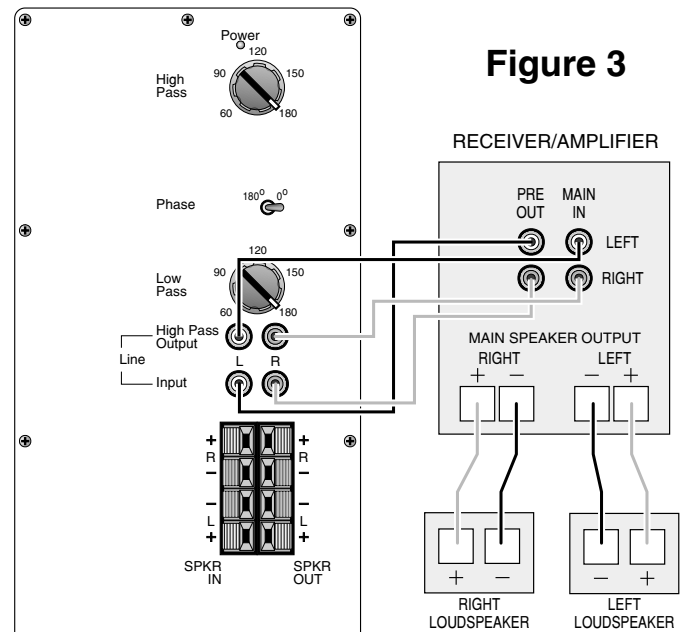

Figure 3

3) If your receiver/amplifier has preamp output jacks and main input jacks for the left and right channels or you have a separate pre-amp/ processor and power amplifier. See Figure 3.

This method of hookup can offer the highest level of performance for your complete loudspeaker system. The PSW-D110/DPS-10 incorporates a variable high-pass crossover *in addition* to a variable low-pass crossover. When hooked up as shown above, the subwoofer will limit the low-frequency information that is returned to your receiver/amplifier. Your receiver/amplifier does not need to waste valuable power reproducing the low frequencies. In addition, since no low-frequency information is being sent to your main loudspeakers, they are able to reproduce mid and high frequencies with greater clarity

TROUBLESHOOTING

If you used the high-level (speaker) inputs and there is no sound from any of the speakers, check the following:

- Receiver/amplifier is on and a source is playing.
- Powered subwoofer is plugged in.
- Check all wires and connections between receiver/amplifier and speakers. Make sure all wires are connected. Make sure none of the speaker wires are frayed, cut or punctured.
- Review proper operation of your receiver/amplifier. If there is low bass output, check the following:
 - Make sure the connections to the left and right “Speaker Inputs” have the correct polarity (+ and –).
 - Make sure that the sub-woofer is plugged into an active electrical outlet.

- Powered subwoofer is plugged in.
- Adjust the crossover point.

If you used the line-level inputs and there is no sound from the subwoofer, check the following:

- Receiver/amplifier is on and a source is playing.
- Powered subwoofer is plugged in.
- Check all wires and connections between receiver/amplifier and subwoofer. Make sure all wires are connected. Make sure none of the wires are frayed, cut or punctured.
- Review proper operation of your receiver/amplifier.

PSW-D112/DPS-12 TEST SET UP AND PROCEDURE

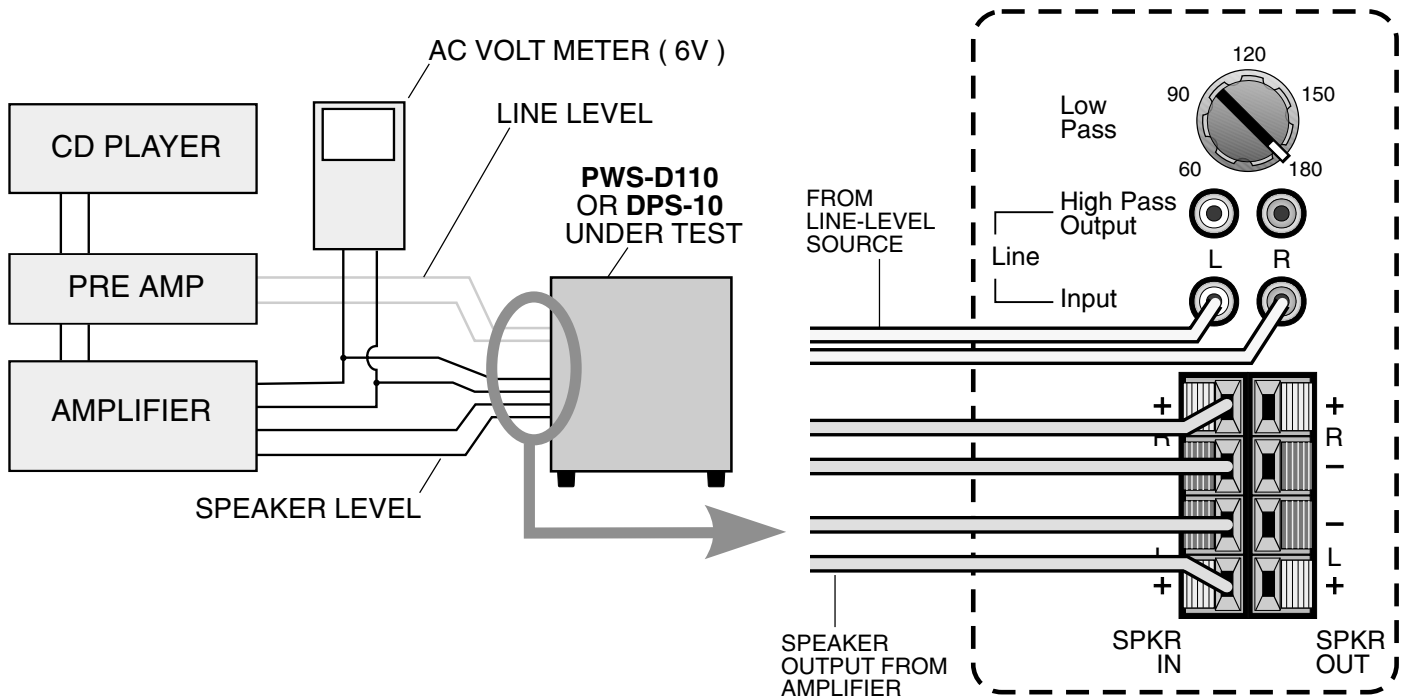

General Function

UUT = Unit Under Test

1. Connect both right and left line level inputs (RCA) to signal generator and UUT. Use Y-cable if necessary from mono source. VOLUME control should be full counterclockwise.
2. Turn on generator, adjust to **50mV, 50 Hz**.
3. Plug in UUT; red LED should be ON. Turn VOLUME control full clockwise. Low Pass control should be set fully clockwise (180).
4. LED should turn Green; immediate bass response should be heard and felt from port tube opening.
5. Turn off generator, turn VOLUME control fully counterclockwise, disconnect RCA cables.
6. Connect one pair of speaker cables to either high level input terminal on UUT. Cables should be connected to an integrated amplifier fed by the signal generator.
7. Turn on generator and adjust so that speaker level output is **2.0V, 50 Hz**. Turn VOLUME control full clockwise.
8. Green LED should light, immediate bass response should be heard and felt from the port tube opening.

Sweep Function

1. Follow steps 1-4 above, using a sweep generator as a signal source.
2. Sweep generator from 20Hz to 300Hz. Listen to the cabinet and drivers for any rattles, clicks, buzzes or any other noises. If any unusual noises are heard, remove driver and test.

Driver Function

1. Remove driver from cabinet; detach + and - wire clips.
2. Check DC resistance of driver; it should be **3.9 ohms**.
3. Connect a pair of speaker cables to driver terminals. Cables should be connected to an integrated amplifier fed by a signal generator and adjust so that speaker level output is **5.0V**.
4. Sweep generator from 20Hz to 1kHz. Listen to driver for any rubbing, buzzing, or other unusual noises.

PSW-D110/DPS-10 TEST PROCEDURE

A. Power Amp Section

1. Resistance Check Resistance from O/P of the module to GND should be >10K (NO LOAD)
Resistance from V+ of the module to V- of the module should read >5k
Resistance from V+ of the module to O/P of the module should read >10K
Resistance from V- of the module to O/P of the module should read >10K
2. Power Up LED RED
3. D.C. Operation

Voltage measurements (DVM)

Between	+6V	V+	O/P	V-	+15V	S/D	FR	I/P	GND	-15V
And	V-	GND	GND	GND	GND	V-	GND	GND	GND	GND
Should be Reading	+6.2V	+43.5v	0V	-43.5V	+15.5V	+5.75V	0V	0V	0V	-15.5V

4. Check Switching Frequency

Use scope (EITHER USES AN ISOLATION TRANSFORMER OR ATTACHES THE PROBE TIP TO SPK- and REFERENCE LEAD TO SPK+)
-Reading 100kHz +/-10%,1Vpp

B. Pre Amp Section

1. Low Level Input Sensitivity
-Set up Turn level and Low-Pass Pot Fully CW
Generator set at 50mV@43Hz
Signal to Low level input

-Voltage measurements

OP AMP						SPEAKER
U1(1)	U1(8)	U1(14)	U1(7)	U2(1)	U2(7)	O/P
415mV	395mV	590mV	603mV	5.73V	5.2V	14.5V

2. High Level Input Sensitivity
-Set up Turn level and Lo Pass Pot Fully CW
Set Generator at 2.55V@43Hz
Signal to High level input

Voltage measurements 14.5V at speaker output

3. Low-Pass

Set upSet Generator at 100mV@100Hz
Signal to Low level input
Measure voltage at speaker output

Voltage measurements

Low-Pass Pot Setting	Output
CW	11.1V
CCW	5.37V

4. High-Pass

-Set up Set Generator at 100mV@at 100Hz
 Signal to Low level input
 Measure voltage at high-pass output

-Voltage measurement

Hi-Pass Pot Setting	Output
CW	24mV
CCW	55mV

4. LED

With a 35mV input signal at a single Low level input, LED should change to green

See flow chart (following page) for detailed diagnostics.

PSW-D/DPS-10 POWER MODULE TESTING FLOW CHART

CAUTION : MODULE OUTPUT IS FLOATING AND IS **NOT** PROTECTED AGAINST A SHORT TO GROUND. ALL TEST INSTRUMENTS CONNECTED TO THE OUTPUT **MUST** BE FLOATING. ATTACH THE SCOPE PROBE TIP TO SPK - and REFERENCE LEAD TO SPK+.

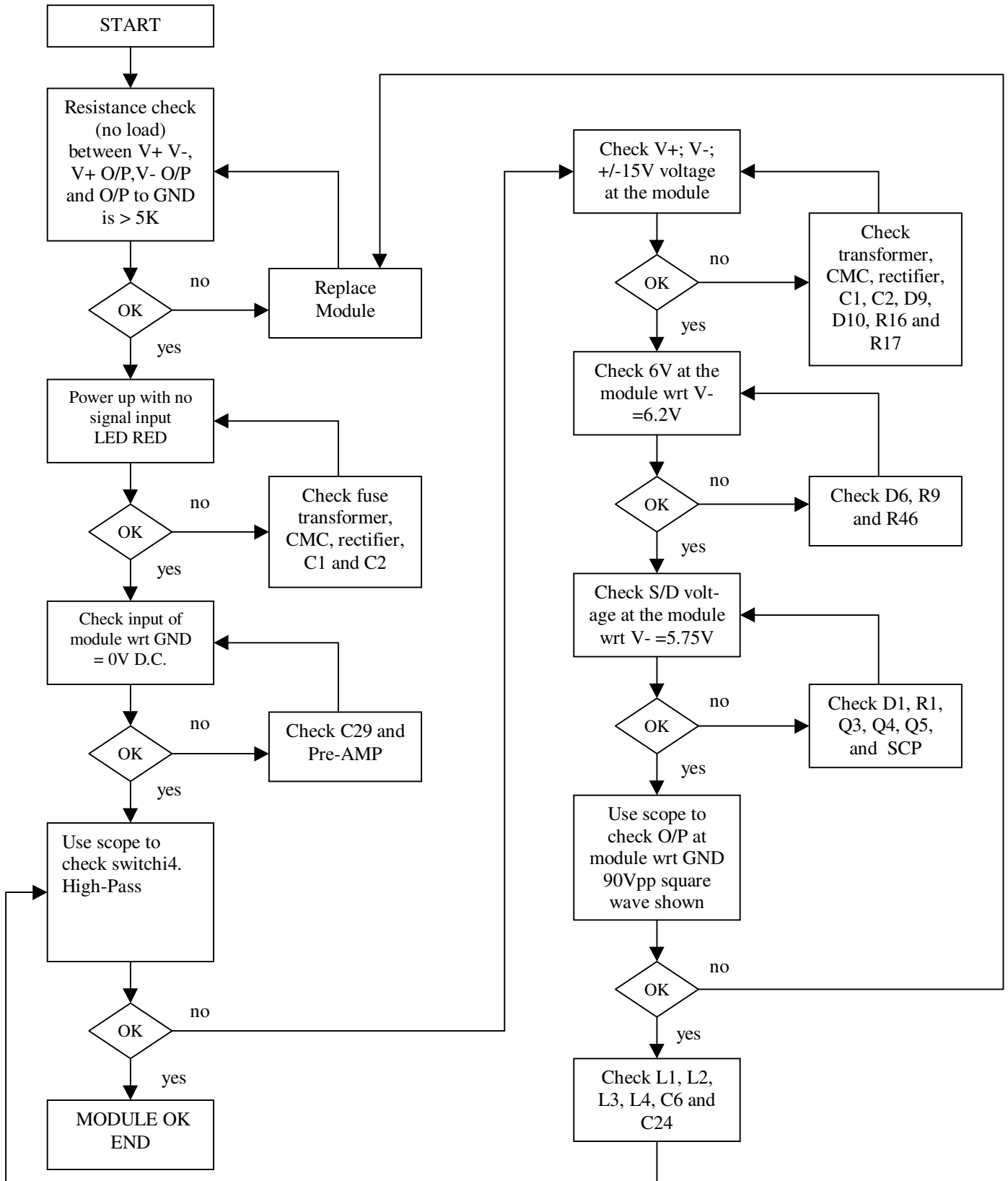

SERVICE BULLETIN JBL9902 REV1 - MAY 1999

To all JBL Service Centers

Model: PSW-D110

Subject: Grille removal

When servicing the PSW-D110 subwoofer, care must be taken when removing the metal subwoofer speaker grille. Removing the grille by grasping one grille edge and pulling it off with a hinge-like action could result in broken grille pins.

To Remove

- 1) Place the subwoofer on a padded surface, with the grille facing upwards.
- 2) Grasp the grille with both hands in two of the opposite cut-outs between the grille and the cabinet.
- 3) Pull up on the grille gently, rocking the grille frame back and forth, evenly on both sides, until the grille is free of the cabinet.

Note:

For grille replacement, there are two versions of the grille.

Earlier version has a .220" (5.6mm) grille pin diameter. JBL Part# 200510

Later version has a .410" (10.4mm) grille pin diameter. JBL Part# 200511

In the case of a missing grille, where pin diameter cannot be measured: take approximate diameter from the rubber grille cups in the subwoofer cabinet.

SERVICE BULLETIN JBL9903 - APRIL 1999

To all JBL Service Centers
Model: PSW-D110/DPS-10

This considered a Minor repair

Subject: Check Solder Joints in Event of Failure

Some performance related complaints in the PSW-D110/DPS-10 powered subwoofer may be caused by cold Solder connections between the 28 pins of the Power Amp Module and the main circuit board. When troubleshooting, failure to check these joints can result in erroneous conclusions or wasted time.

In the event you receive a PSW-D110/DPS-10 Subwoofer with the complaints "Dead, or No Output, or Motorboating (Oscillation)", perform the steps listed below first before any further troubleshooting takes place:

- 1) Unplug all cables, lay the subwoofer on a padded surface.
- 2) Remove all Philips screws around the outer perimeter of the amplifier faceplate.
- 3) Remove amplifier assembly; you should be able to remove the amplifier far enough out of the cabinet to service it without removing the woofer wires.
- 4) Locate the Power Amp Module; it is the large gray component with a metal case. On the Solder side of the circuit board are the 28 Solder connections to the Module.
- 5) Regardless of whether you can visibly see breaks in any of the connections or not, carefully re-Solder all 28 pin connections, adding 60/40 rosin core Solder. Take care not "bridge" any connections on the board with Solder.
- 6) Inspect the Solder joints to the main filter capacitors C1 and C2 on the main PCB and re-Solder if needed.
- 7) Replace the amplifier assembly back into the cabinet; replace the screws.
- 8) Test the unit by applying a signal from a music source, adjust the volume to a moderate level and confirm the original problem has been corrected.

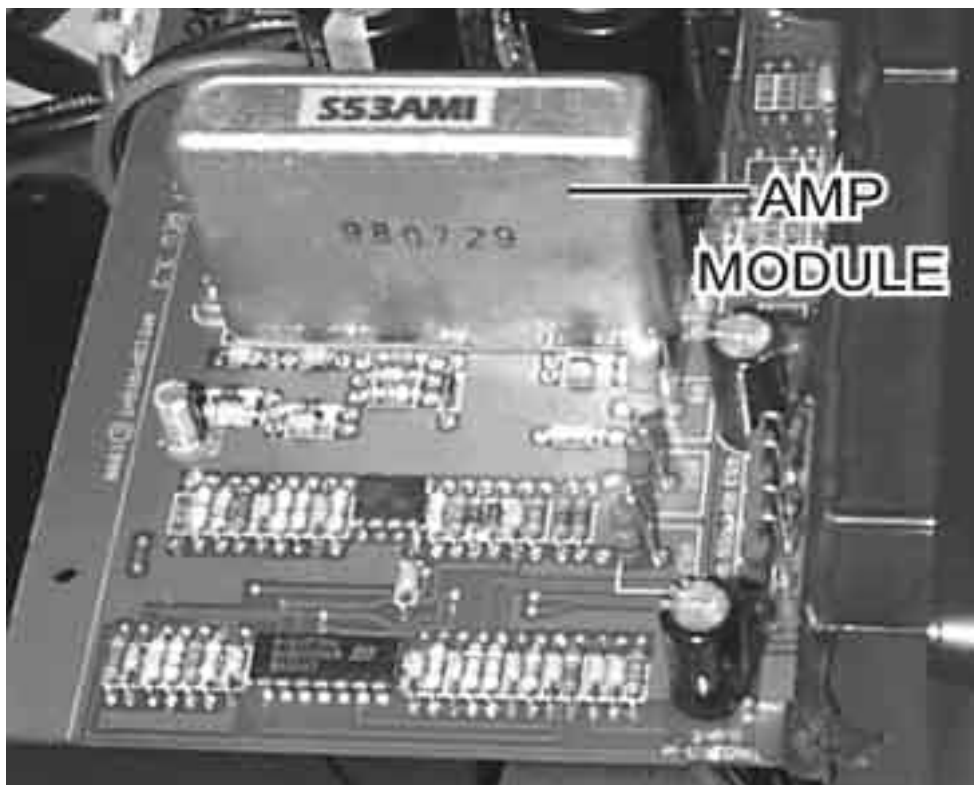

SERVICE BULLETIN JBL2000-01 - JANUARY 2000

To all JBL Service Centers
 Model: PSW-D110/DPS-10

Warranty labor rate: MINOR repair

Subject: Failure of C6

In the event you receive a JBL subwoofer corresponding to one of the above models with the complaint "no output" and capacitor C6 (10uf 50v NPE) is damaged in the amplifier, replace with the following part: JBL part# 30712 (10uf 100v NPE)

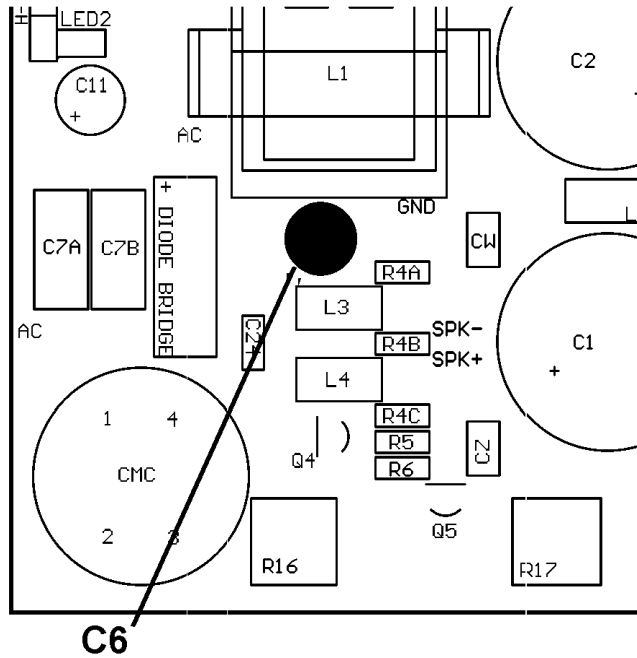

General reference for location only; not all parts or designators may conform to these drawings

It is also recommended following the repair that the instructions included in bulletin #JBL9903 are followed.

Models	Serial number 120/230V	Status	Action
PSW-D110/DPS-10	All serial numbers affected	Replace if damaged	Replace C6 with JBL part# 30712

CABINET EXPLODED VIEWS

**DPS-10
CABINET ASSEMBLY**

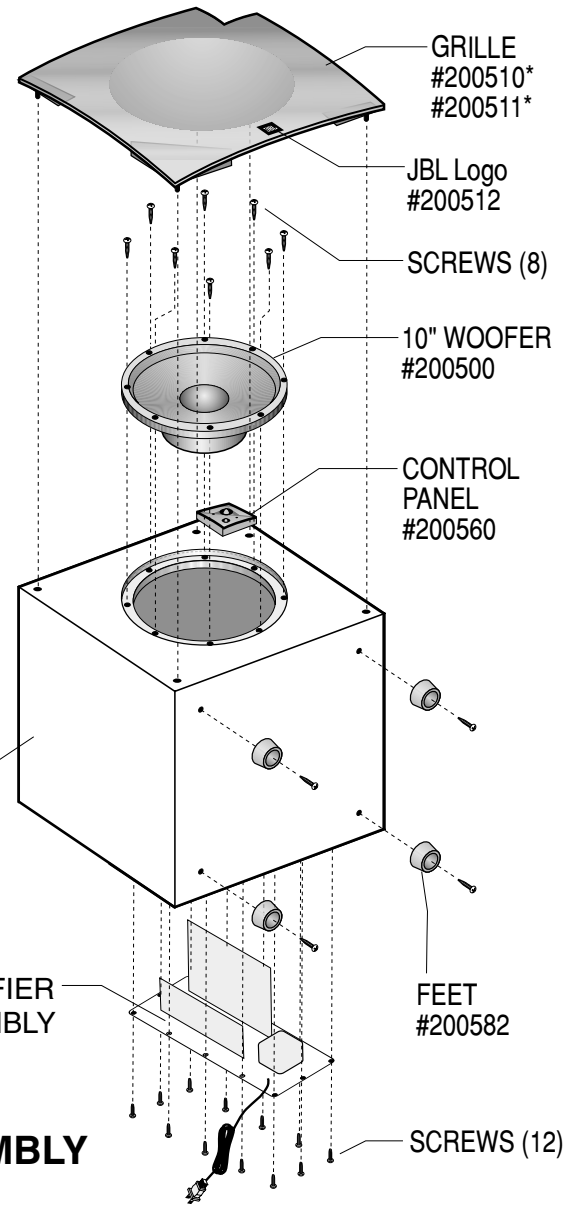
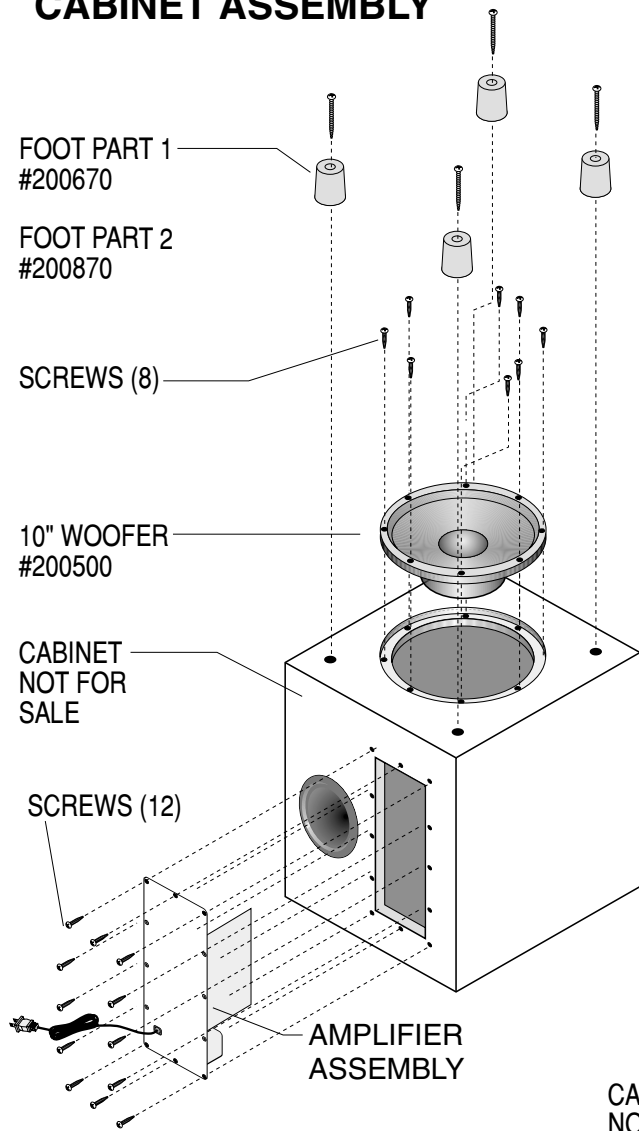

**PSW-D110
CABINET ASSEMBLY**

* For grille replacement, there are two versions of the grille. Earlier version has a .220" (5.6mm) grille pin diameter. JBL Part# 200510. Later version has a .410" (10.4mm) grille pin diameter. JBL Part# 200511. In the case of a missing grille, where pin diameter cannot be measured: take approximate diameter from the rubber grille cups in the subwoofer cabinet.

AMPLIFIER EXPLODED VEIW

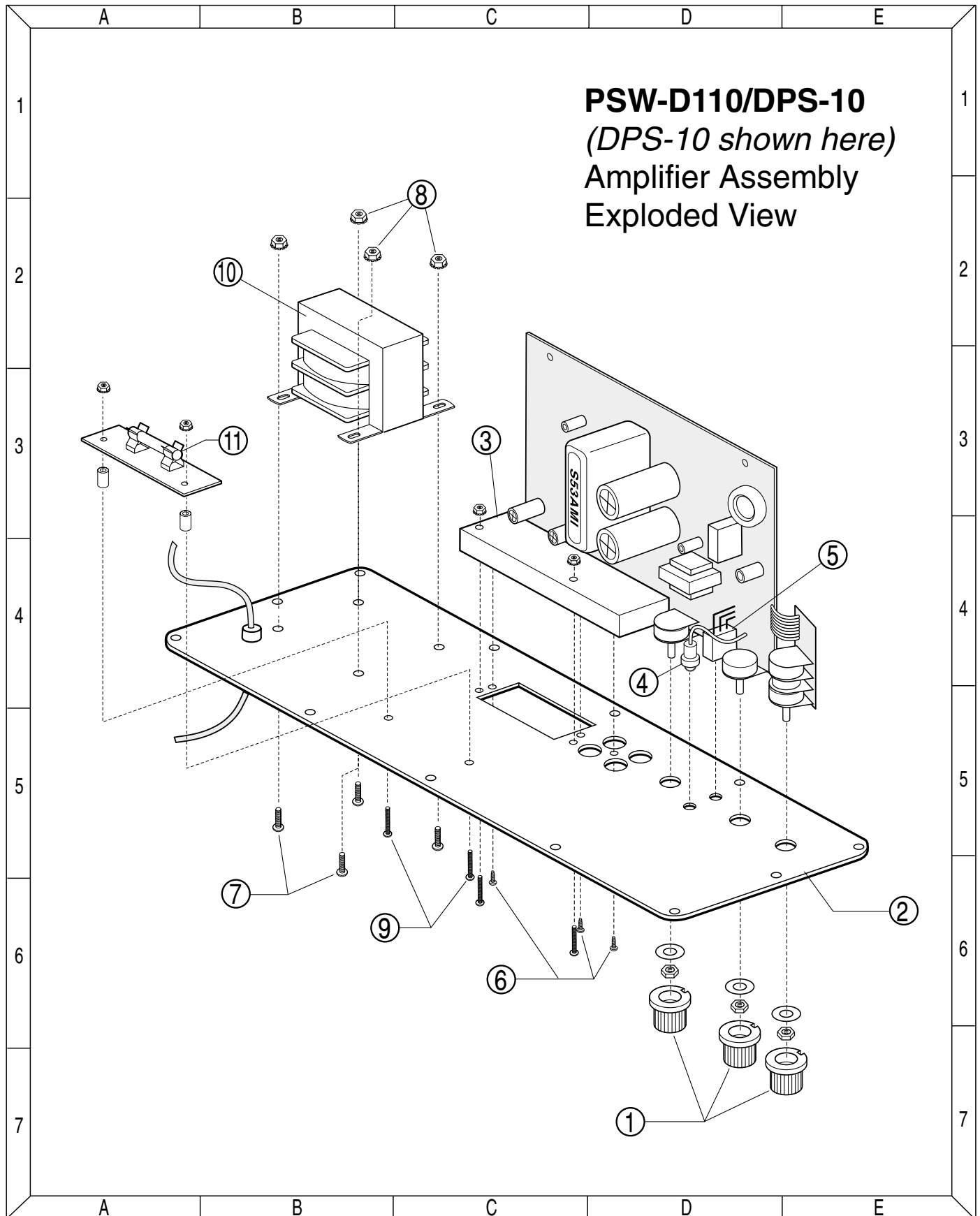

PSW-D110/DPS-10 MECHANICAL PARTS LIST

Ref.#	PartNumber	Description	Qty	Ref.#	PartNumber	Description	Qty
PSW-D110/DPS-10				DPS-10(Only)			
3	70307	AIR LEAK COVER	1	1	70302	KNOBS DPS-10	3
4	70308 \triangle	SAFETY PART PSW-D110 LED SOCKET	1	2	70306	FACEPLATE DPS-10	1
5	70150	PHASE SWITCH	1	200620	CARTON DPS-10		
6	70170	SCREWS TO SECURE INPUT JACKS #4X.5" MACHINE SCREW	3	200621	TOP STYRO RAIL(2) PER BOX DPS-10		
7	70171	BOLTS FOR TRANSFORMER #10 X 1 MACHINE SCREWS	4	200622	BOTTOM STYRO RAIL(2) PER BOX DPS-10		
8	70172	NUTS FOR TRANSFORMER #10 KEPS NUT	4	200630	120V DPS-10 OWNER'S MANUAL		
9	70173	SCREWS FOR FUSE PCB #6 X .5"	2	200640	PLASTIC BAG DPS-10		
10	80113 \triangle	TRANSFORMER #4472 SAFETY PART	1	200650	AMPLIFIER DPS-10		
11	80114 \triangle	250V, 1.25A, T type SLO BLO fuse SAFETY PART	1	200670	FOOT		
	108115	HIGH LEVEL INPUT AND OUTPUT TERMINALS	1				
	108321	QUAD RCA INPUT JACKS	1				
	200500	PSW-D110 10" WOOFER	1				
PSW-D110(Only)							
1	70302	KNOBS PSW-D110	2				
2	70310	PWS-D110 FACEPLATE	1				
	200510*	GRILLE COMPLETE PSW-D110	1				
	200511*						
	200520	CARTON PSW-D110	1				
	200530	120V PSW-D110 OWNER'S MANUAL	1				
	200550	AMPLIFIER PSW-D110	1				
	200560	CONTROL PANEL PSW-D110	1				
	40402	VOLUME CONTROL AND HARNESS PSW-D110	1				
	200580	LED AND HARNESS PSW-D110	1				
	200582	FOOT	4				

* For grille replacement, there are two versions of the grille. Earlier version has a .220" (5.6mm) grille pin diameter. JBL Part# 200510. Later version has a .410" (10.4mm) grille pin diameter. JBL Part# 200511. In the case of a missing grille, where pin diameter cannot be measured: take approximate diameter from the rubber grille cups in the subwoofer cabinet.

PACKING EXPLODED VIEWS

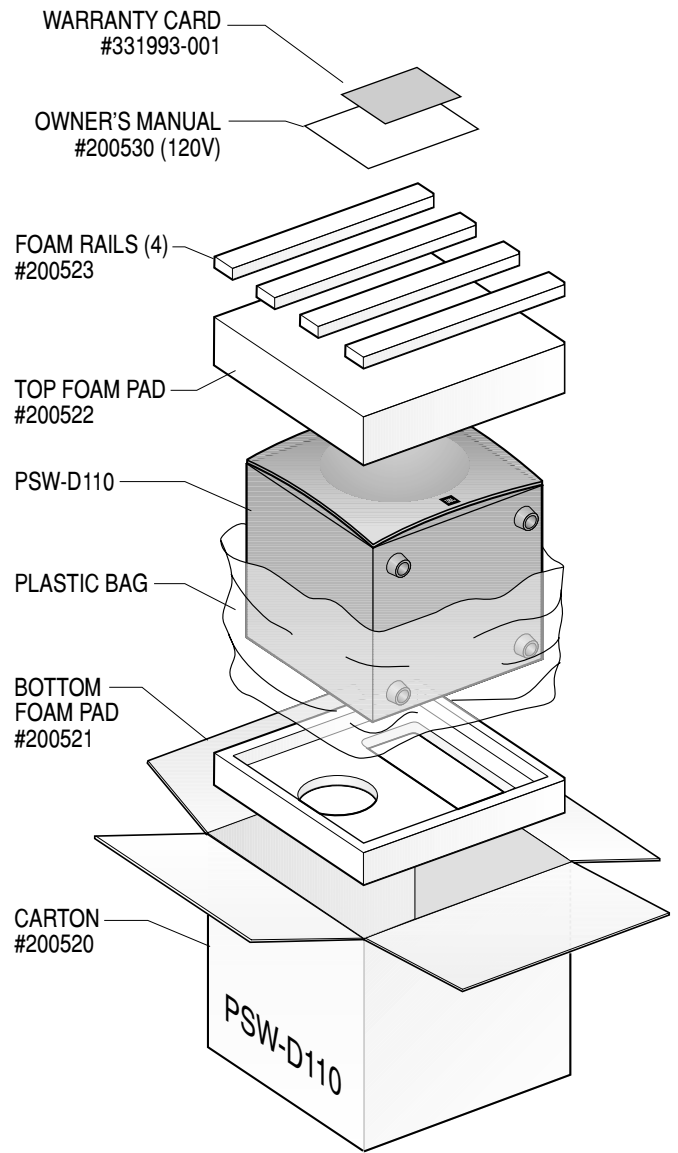
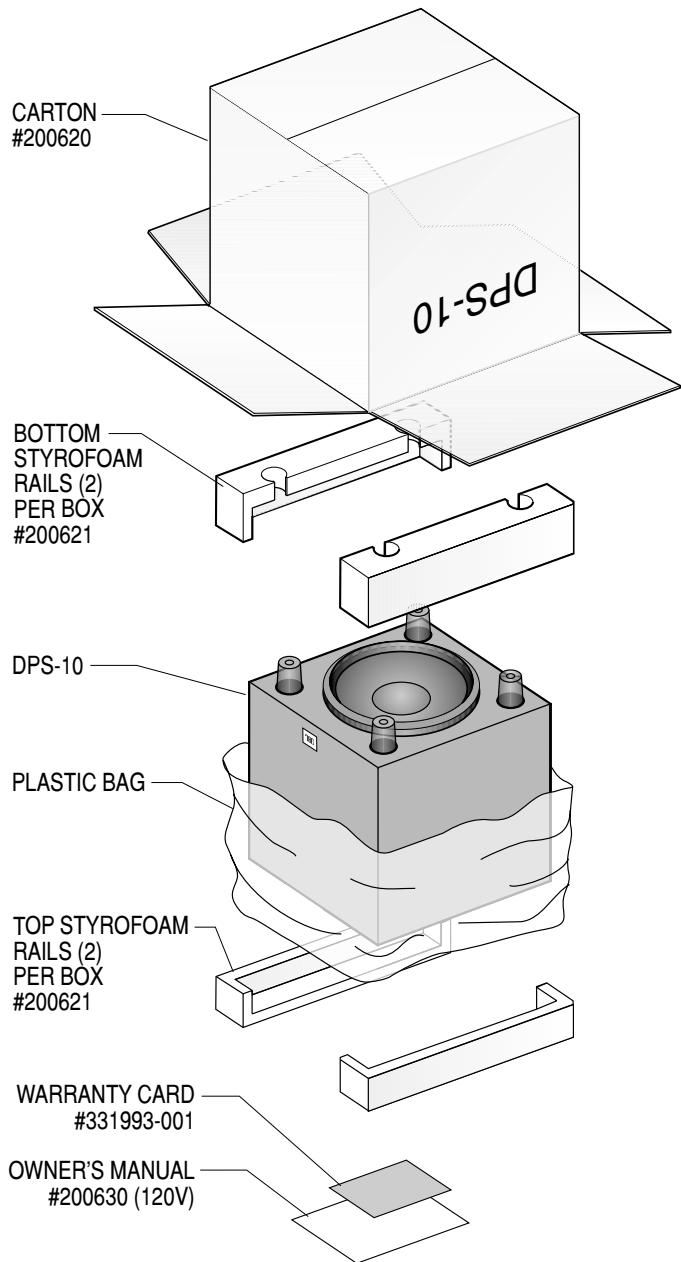

PSW-D110/DPS-10 Version 3.53 PCB (Component Side)

Revision 3.53 - Component Side Trace Layer

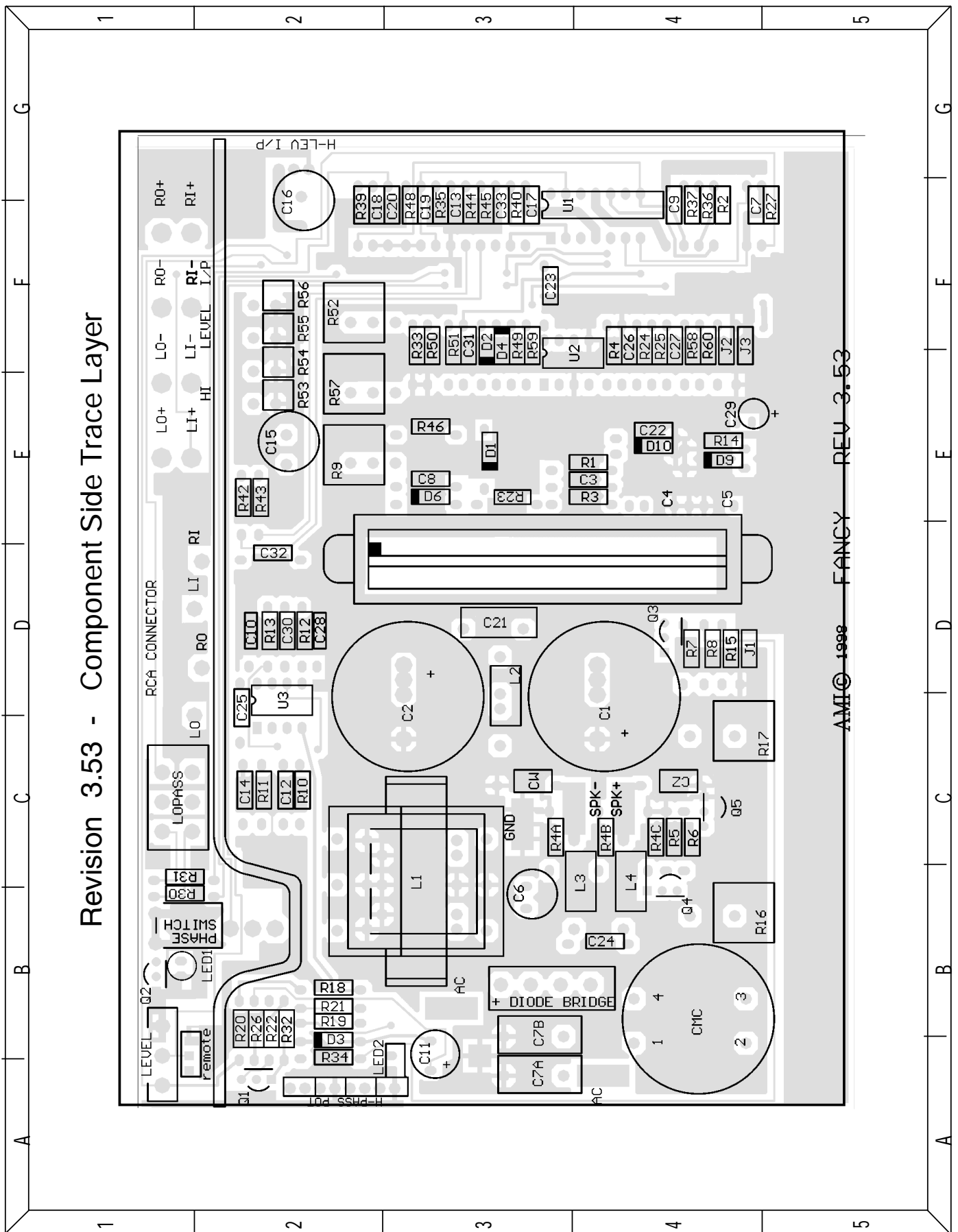

AMIC 1998 FANCY REV 3.53

PSW-D110/DPS-10 Version 3.53 PCB (Solder Side)

Revision 3.53 - Solder Side Trace Layer as viewed through the board

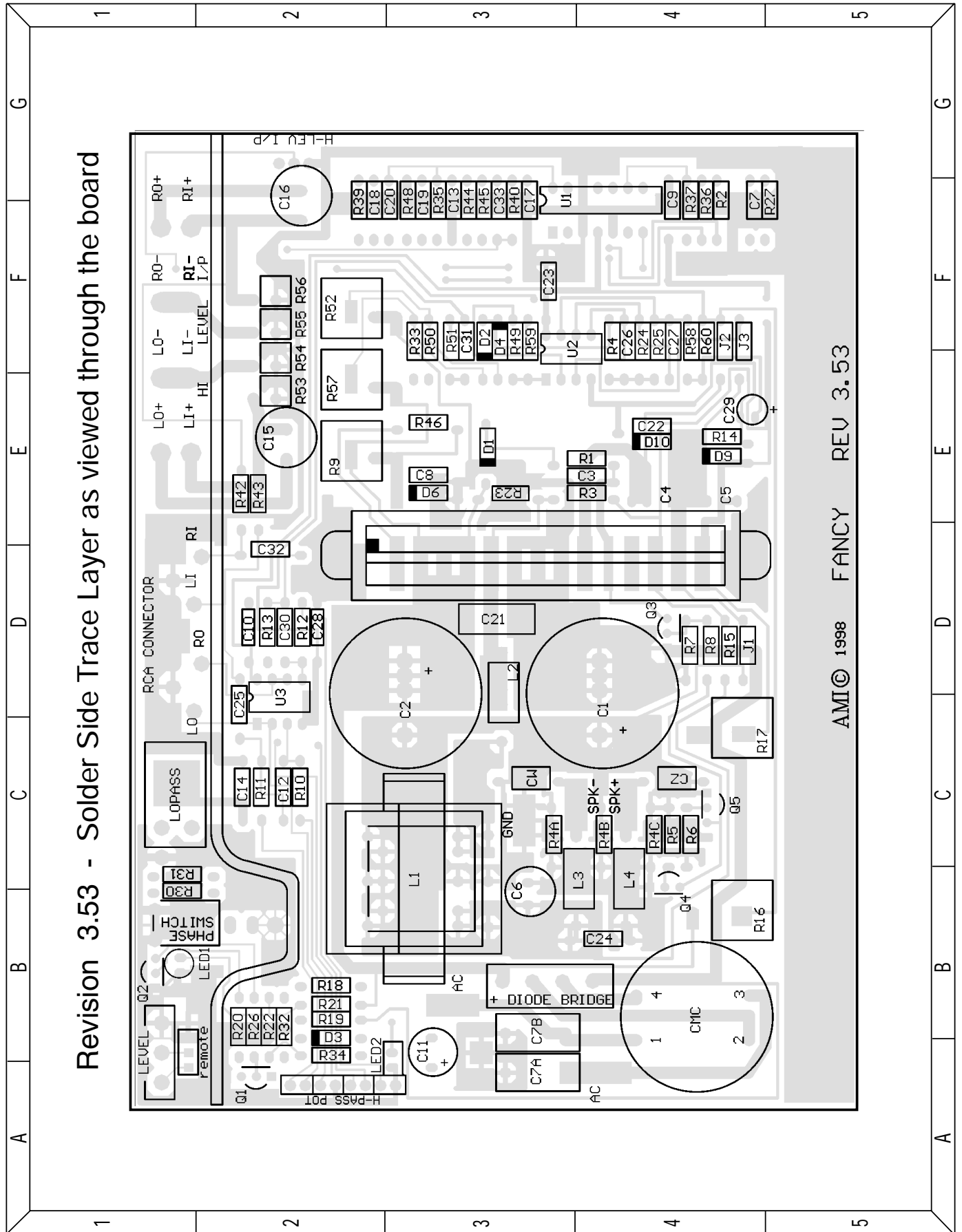

AMI© 1998 FANCY REV 3.53

PSW-D110/DPS-10 Version 3.93 PCB (Component Side)



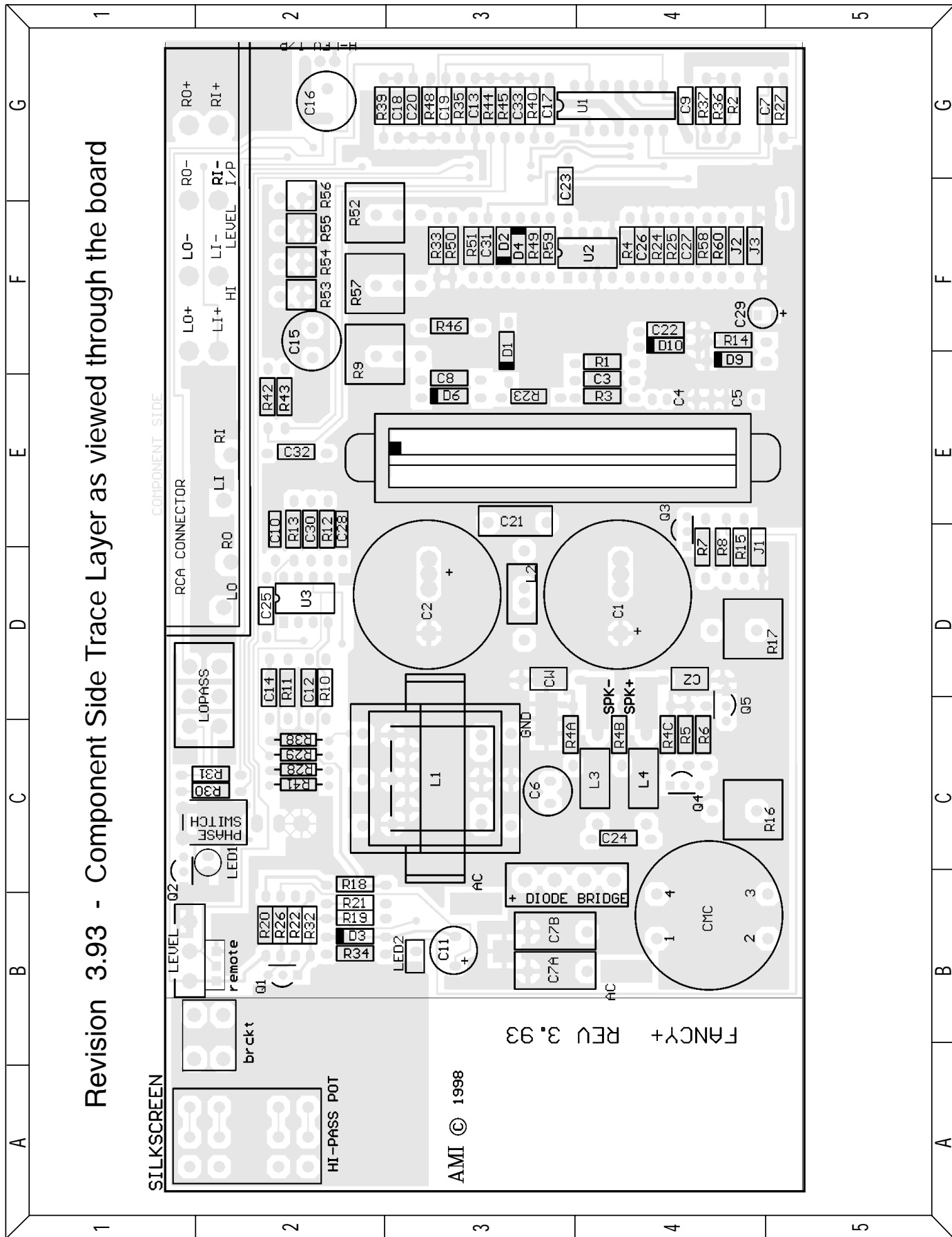

Revision 3.93 - Component Side Trace Layer as viewed through the board



AMI © 1998

FANCY+ REV 3.93

PSW-D112/DPS12 PARTS LIST

Ref.#	PartNumber	Description	Qty	Ref.#	PartNumber	Description	Qty
Low Pass	40425	50K 0.25W 10% DOUBLE LOG POT	1	C6	30705 	10uF 50V -4% ELECTROLYTIC RADIAL NP 1 SAFETY PART SeePage14ServiceBulletin	1
Level	40402	5K 0.25W 10% SINGLE LINEAR POT	1	C7	30510	33nF 50V 10% MONO-CERAMIC AXIAL	1
High Pass	40436	20K 0.25W 10% QUAD LINEAR POT.	1	C7a/b	30505	100nF 100V 20% METAL POLY RAD	1
Resistors				C11	30702	100uF 35V -4% ELECTROLYTIC RAD	1
R1	40703	8200K 0.25W 5% CARBON FILM	1	C12, 20, 25	30514	47nF 50V 10% MONO-CERAMIC AXIAL	3
R2, 36, 58	40446	8.66K 0.25W 1% METAL FILM	3	C13	30507	10nF 50V 20% MONO-CERAMIC AXIAL	1
R3	40412	33.2K 0.25W 1% METAL FILM	1	C14	30511	330nF 50V 10% MONO-CERAMIC AXIAL	1
R4	40437	56K 0.25W 5% CARBON FILM	1	C15, 16	30707	220uF 50V 20% ELECRTOLYTIC RADIAL	2
R4a/b/c	40105	0.1 0.5W 5% 3PCS.	1	C17, 24, 28	30502	100nF 50V 20% MONO-CERAMIC AXIAL 3 Part#30504 can be subbed for #30504	3
R5, 6	40420	1K 0.25W 5% CARBON FILM	2	C18, 19	30517	68nF 50V 10% MONO-CERAMIC AXIAL	2
R7, 14, 21, 44 45	40409	10K 0.25W 5% CARBON FILM	5	C26	30518	15nF 50V 10% MONO-CERAMIC AXIAL	1
R8, 15	40406	100K 0.25W 5% CARBON FILM	2	C27, 33	30503	2.2nF 50V 10% MONO-CERAMIC AXIAL	2
R9	40421	3.9K 5W 5% 3W CAN BE USED	1	C29	30705	10uF 50V 20% ELECTROLYTIC RADIAL	1
R10, 11, 12, 13	40438	20K 0.25W 1% METAL FILM	4	C30	30520	470nF 50V 10% MONO-CERAMIC AXIAL	1
R16, 17	40101	820 2W 5% CARBON FILM	2	C31, 32	30514	47nF 50V 10% MONO-CERAMIC AXIAL	2
R18	40407	220K 0.25W 5% CARBON FILM	1	Diodes			
R19	40422	1K 0.5W 5% CARBON FILM	1	D1	50101	1N5256B 30V 5% 0.5W	1
R20, 23	40405	4.7K 0.25W 5% CARBON FILM	2	LED 1 or 2	50106	DUAL CIR LED (2 LEGGED)	2
R22	40410	2.2K 0.5W 5% CARBON FILM	1	D2, 4	50104	1N4148 100V 0.1A	2
R24	40439	27K 0.25W 5% CARBON FILM	1	D3	50102	1N4749A 24V 5% 1W	1
R25	40437	56K 0.25W 5% CARBON FILM	1	D6	50103	1N5234B 6.2V 5% 0.5W	1
R26	40701	1000K 0.25W 5% CARBON FILM	1	D9, 10	50105	1N4744A 15V 5% 1W	2
R27	40440	6.81K 0.25W 1% METAL FILM	1	DBR	50100 	BRIDGE RECT 200V 4A SAFETY PART	1
R30	40441	13.7K 0.25W 1% METAL FILM	1	Transistors			
R32, 49	40415	470K 0.25W 5% CARBON FILM	2	Q1	60151	MPS A13 30V NPN(DARL)	1
R33	40100	332 0.5W 5% CARBON FILM	1	Q2	60152	2N3906 40V PNP 2N4402 ALTERNATE	1
R35	40442	301K 0.25W 1% METAL FILM	1	Q3	60153	2N3904 40V NPN 2N4401 ALTERNATE	1
R39	40439	27K 0.25W 1% METAL FILM	1	Q4, 5	60154	MPS A56 80V PNP	2
R40	40443	39K 0.25W 5% METAL FILM	1	IntegratedCircuits			
R42, 43	40406	100K 0.25W 5% CARBON FILM	2	U1	60100	LM324 QUAD OPAMP 15	1
R46	40104	4.7 0.25W 5% CARBON FILM	1	U2, U3	60101	TLO 82 DUAL OPAMP 15	2
R48	40432	6.98K 0.25W 1% METAL FILM	1	60301	S52AMI 	POWER AMP MODULE SAFETY PART	1
R50	40100	332 0.25W 5% CARBON FILM	1	Inductors			
R51	40417	47K 0.25W 5% CARBON FILM	1	CMC1	80100 	MC4438 SAFETY PART	1
R52, 57	40404	1K 2W 5% CARBON FILM	2	L1	80101 	MC4436 SAFETY PART	1
R53, 54, 55, 56	40106	100 2W 5% CARBON FILM	1	FERRITE BEAD	80102	BL02RN2-R62	
R59	40405	4.7K 0.25W 5% CARBON FILM	1	TRX1	80113	POWER TRANSFORMER #4472	1
R60	40431	68K 0.25W 5% CARBON FILM	1				
Capacitors							
C1	30706	4700uF 50V -4% ELECTROLYTIC RADIAL	1				
C2	30703	4700uF 50V -4% ELECTROLYTIC RADIAL	1				
C3, 4, 5, 8, 9, 10	30504	100nF 50V 10% MONO-CERAMIC AXIAL	6				

PSW-D110/DPS-10 INTEGRATED CIRCUITS

S53AMI/S64AMI - Power Amp module SAFETY PART

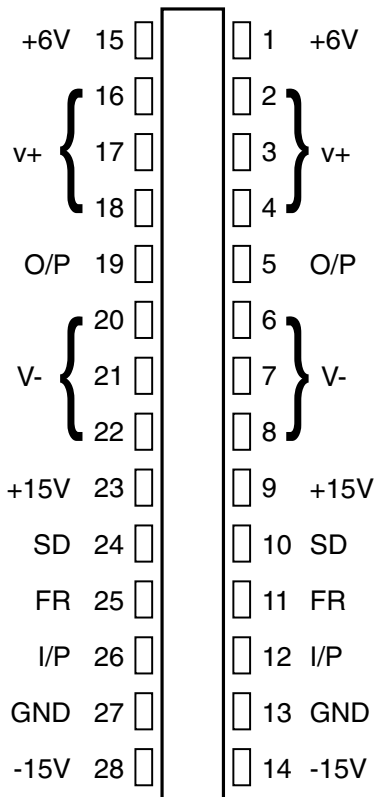

NOTE: THE FOLLOWING PROCEDURES MUST BE FOLLOWED WHEN INSTALLING NEW S53AMI/S64AMI AMP MODULES: FAILURE TO FOLLOW ONE OR MORE OF THESE STEPS MAY RESULT IN THE INSTANT DESTRUCTION OF THE MODULE WHEN POWERED UP.

- 1) Align white indent marker on Amp Module with indent marker on main PCB; alternately observe position of label on the top of the module; incorrectly replacing the Module 180 in the PCB slot will result in its destruction.
- 2) All AC powered test instruments (meters, oscilloscopes, etc.) must have a floating ground, i.e. be connected to an isolation transformer.
- 3) Align and position the Amp Module before soldering.
- 4) Attach the amp Module with the mounting screws before soldering or powering up.
- 5) Use only rosin-core or non-acid core solder; thoroughly de-flux the surfaces after soldering.

If the new S53AMI/S64AMI Amp Module has larger mounting hole(s) in the case, and the stock screws no longer will fit, and screws of the proper type cannot be obtained locally order:
 (2) part# 60301S (screws)
 (2) part# 60301N (nuts)

U1 - (LM324) Quad Op Amp

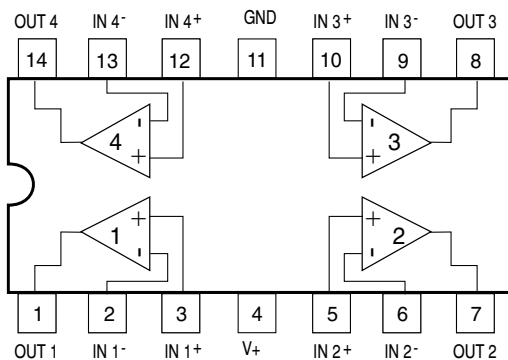

U2, U3 - (TLO 82) Dual Op Amp

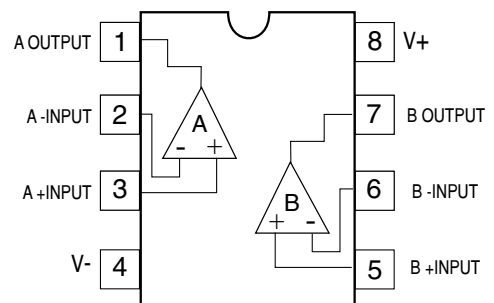

Q4, 5 - (MPS A56) 80V PNP Transistor

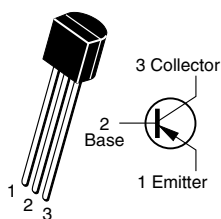

Q2 - (2N3906) 40V PNP Transistor

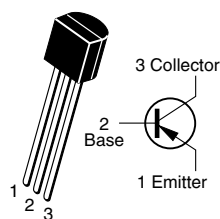

Q3 - (2N3904) 40V NPN Transistor

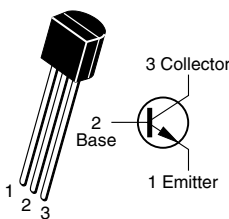

Q1 - (MPS A13) 30V NPN(Darl) Transistor

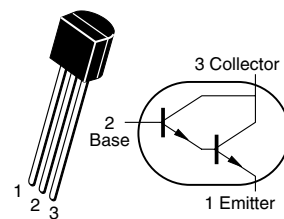

PWS-D110/DPS-10 SCHEMATIC 2 of 2

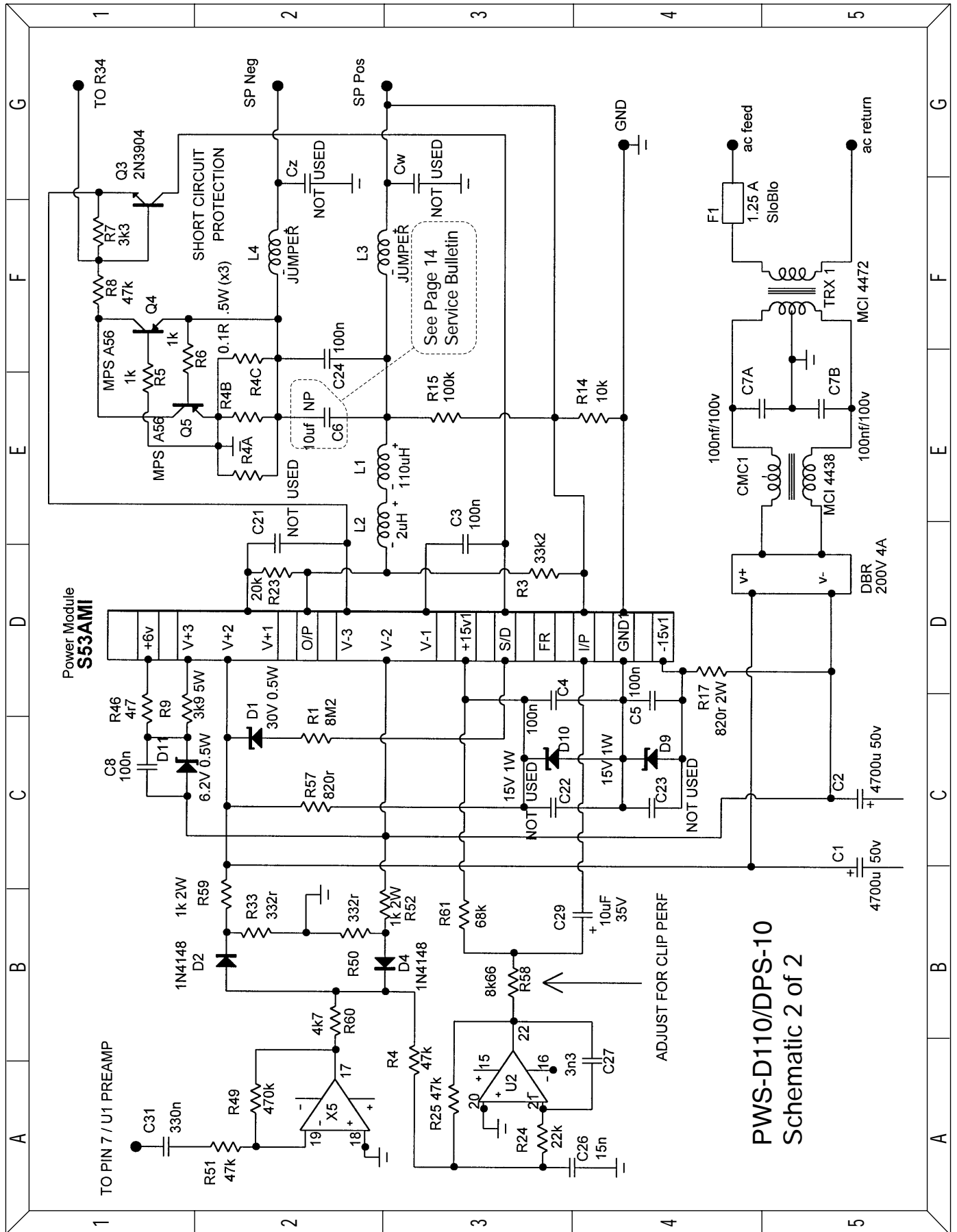

PWS-D110/DPS-10 Schematic 2 of 2