

JBL

Simply Cinema

SCS135

Home Theater Speaker System

SERVICE MANUAL



JBL Incorporated

250 Crossways Park Dr.

Woodbury, New York 11797

REV 1 5/2001

TABLE OF CONTENTS

BASIC SYSTEM SPECIFICATIONS3
DETAILED SUB135 SPECIFICATIONS4
CONNECTIONS5
OPERATION7
TROUBLESHOOTING8
MECHANICAL/PACKAGING PARTS LIST9
SUB135 DETAILED EXPLODED VIEW10
TEST SET UP AND PROCEDURE11
PACKAGING12
ELECTRICAL PARTS LIST13
INTEGRATED CIRCUIT DIAGRAMS16
PRINTED CIRCUIT BOARDS17
SCHEMATICS20

Specifications

SCS135 SYSTEM

Frequency Response 35Hz - 20kHz (-6dB)

Satellites

Recommended Power 10 - 100 watts

Impedance 8 ohms nominal

Sensitivity 86dB @ 1 watt/1 meter

Tweeter One 1/2" titanium-laminate dome, video-shielded

Midrange One 3" driver, video-shielded

Dimensions (H x W x D)
4-3/8" x 3-3/16" x 3-3/4"
111mm x 81mm x 95mm

Weight 1.1lb/0.5kg

Center Channel

Recommended Power 10 - 50 watts

Impedance 8 ohms nominal

Sensitivity 86dB @ 1 watt/1 meter

Tweeter One 1/2" titanium-laminate dome, video-shielded

Midrange Dual 3" drivers, video-shielded

Dimensions (H x W x D)
3-1/4" x 7-5/8" x 3-3/4"
83mm x 194mm x 95mm

Weight 1.89 lb/0.86kg

SUB135 Subwoofer

100 watts RMS

8" woofer, bass-reflex enclosure

Dimensions (H x W x D)
15" x 13" x 14"
381mm x 330mm x 356mm

Weight 30 lb/13.6kg

Refinements may be made on occasion to existing products without notice, but will always meet or exceed original specifications unless otherwise stated.

Simply Cinema is a registered trademark of JBL, Incorporated.

SUB135 Detailed Specifications

SUB135 Amplifier 100W Powered Sub/ Plate Amp

LINE VOLTAGE	Yes/No	Hi/Lo Line	Unit	Notes	
US 120vac/60Hz	Yes	108-132	Vrms	Normal Operation	
Asia 100vac/50Hz	Yes	90-110	Vrms	Normal Operation	
Parameter	Specification	Unit	QA Test Limits	Conditions	Notes
Amp Section					
Type (Class AB, D, other)	AB	AB	n/a		External Sink required for Class AB
Load Impedance (speaker)	4	Ohms	n/a	Nominal	Z-curve required
Rated Output Power	100	Watts	95	1 input driven	
THD @ Rated Power	0.08	%	0.3	22k filter	
THD @ 1 Watt	0.1	%	0.5	22k filter	
DC Offset	10	mV-DC	20	@ Speaker Outputs	
Damping factor	>100	DF	50		Measured at speaker terminals, Output power 90 Watts THD 0.1 %
Input Sensitivity					
Input Frequency	50	Hz	50	Nominal Freq.	1 input driven
Line Input (L&R)	250	mVrms	±2dB	To Rated Power	1 input driven
LFE Input	135	mVrms	±2dB	To Rated Power	LFE input driven only
Speaker/Hi Level Input	2.5	Vrms	±2dB	To Rated Power	(-20 dB below Line In)... 1 input driven
Signal to Noise					
SNR-A-Weighted	100	dB	90	rel. to rated power	A-Weighting filter
SNR-unweighted	80	dB	75	rel. to rated power	22k filter
SNR @ 1W-unweighted	60	dB	55	rel. to 1W Output	22k filter
Residual Noise Floor	1.5	mVrms	2.5	Volume @max, using RMS reading DMM/VOM (or A/P)	
Residual Noise Floor	1	mVrms(max)	2	Volume @max, w/ A/P Swept Bandpass Measurement (Line freq. + harmonics)	
Input Impedance					
Line input L&R, LFE	>15	K ohms	n/a	Nominal	
Speaker/Hi Level Input	4.7	K ohms	n/a	Nominal	
Filters					
Low Pass (fixed or variable)	fixed	--	±2dB		
Slope & Q		dB/Octave	n/a		
Subsonic filter (HPF)		Hz	±2dB		
Slope & Q		dB/Octave	n/a		
Limiters (yes/no)	YES	--	n/a		
Features					
LFE Input	YES		functional		BW Limited to 500 Hz
Volume pot Taper (lin/log)	log	--	functional		
ATO	YES		functional		
Input Configuration					
Line In (L,R)	L,R	--	functional		RCA inputs: L, R Summed to Mono
Line level in LFE	LFE		functional		
Spkr/Hi Level In (L,R)	L,R	--	functional		L, R Summed to Mono
Signal Sensing (ATO)					
Auto-Turn-On (yes/no)	YES	--	functional		
ATO Input Frequency	50	Hz	functional		
ATO Level	2	mV	functional	driven	
ATO Turn-on time	5	ms	functional	AC on, signal applied	
Auto Mute/ Turn-OFF Time	15	minutes	functional	T before muting, after signal is removed	Auto turn of time (T) must be 10 > T < 15
Power on Delay time	3	sec.	functional	AC Power Applied	
Transients/Pops					
ATO Transient	5	mV-peak	10	@ Speaker Outputs	
Turn-on Transient	50	mV-peak	100	@ Speaker Outputs	AC Line cycled from OFF to ON
Turn-off Transient	50	mV-peak	100	@ Speaker Outputs	AC Line cycled from ON to OFF
Efficiency					
Stand-by Input Power	13	Watts	15	@ nom. line voltage	Maximum allowable input power.
Power Cons. @ rated power	185	Watts	195	@ nom. line voltage	100 Watts @ 4 Ohms nominal line voltage
Protection					
Short Circuit Protection	YES	--	functional	Direct short at output	
Thermal Protection	65	deg. C	--	functional	@ 1/8 max unclipped Power rise
DC Offset Protection	YES	--	functional	DC present at Speaker Out leads	Relay or crowbar (for driver/fire protection)
Line Fuse Rating	2.5	Amps	2.5	Type-T or Slo Blo	External fuse with UL/SEMKO rated holder

Connections

SPEAKER CONNECTIONS

Connection Tips

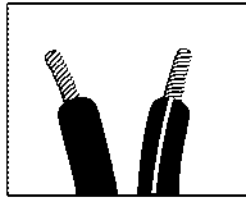

Separate and strip the ends of the speaker wire as shown. Speakers and electronics terminals have corresponding (+) and (-) terminals. Most manufacturers of speakers and electronics, including JBL, use red to denote the (+) terminal and black for the (-) terminal.

The (+) lead of the speaker wire is noted with a stripe. It is important to connect both speakers identically: (+) on the speaker to (+) on the

amplifier and (-) on the speaker to (-) on the amplifier. Wiring "out of phase" results in thin sound, weak bass and a poor stereo image.

With the advent of multichannel surround-sound systems, connecting all of the speakers in your system with the correct polarity remains equally important in order to preserve the proper ambience and directionality of the program material.

00334-1

Dolby® Pro Logic® (Non-Digital) - Speaker Level

Use this installation method for Dolby Pro Logic applications (not Dolby Digital, DTS® or other digital processing), where the receiver/processor does not have a subwoofer output, or a volume-controlled preamp (line-) level output.

Connect your receiver or amplifier's front left and right speaker terminals to the left and right terminals on the subwoofer that are marked "High Level In." Connect the left and right terminals on the subwoofer that are marked "High Level Out" to the corresponding terminals on the back of your front left and right speakers.

Connect your receiver or amplifier's center, left and right surround-speaker terminals to the corresponding terminals on the back of your center, left and right surround speakers.

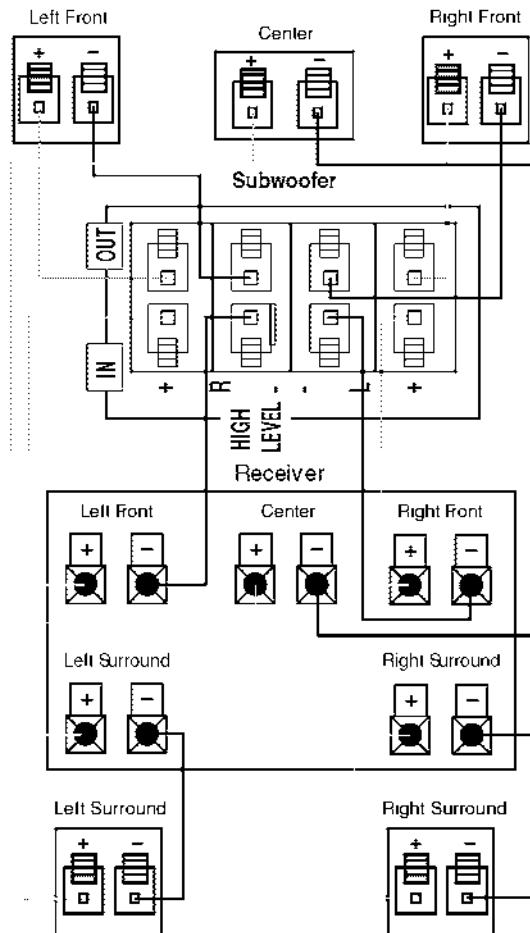

00334-2

Connections (Cont.)

Dolby Pro Logic (Non-Digital) - Line Level

Use this installation method for Dolby Pro Logic applications (not Dolby Digital, DTS or other digital processing), where the receiver/processor is equipped with a subwoofer output, or a volume-controlled preamp (line-) level output.

Use RCA-type patch cords to connect the line-level subwoofer outputs on your receiver or amplifier to the line-level inputs on the subwoofer. **IMPORTANT:** Do not use the LFE input on the subwoofer with Dolby

Pro Logic processors. Note: If your receiver or amplifier only has one subwoofer output jack, then you will need to use a Y-connector (not included). Plug the male end of the Y-connector into your receiver or amplifier's subwoofer output jack, and connect each of the two female ends to separate RCA-type patch cords. Finally, plug the RCA-type patch cords into the line-level inputs on the subwoofer. Connect each speaker to the corresponding speaker terminals on your receiver or amplifier.

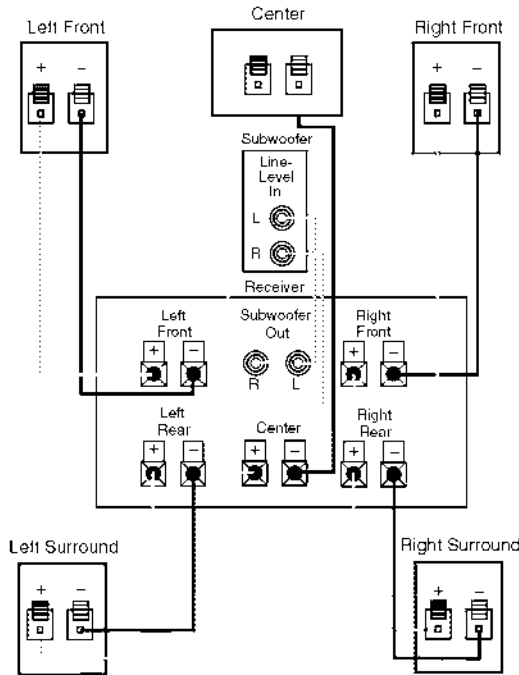

Dolby Digital or DTS (or Other Digital Surround Mode) Connection

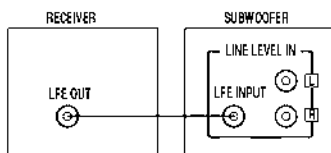

Use this installation method for Dolby Digital, DTS or other digital surround processors: Use the line-level input jack marked "LFE" for the Low-Frequency Effects channel. Connect this jack to the LFE output or subwoofer output on your receiver or amplifier. Connect each speaker to the corresponding speaker

terminals on your receiver or amplifier. Make sure that you have configured your surround-sound processor for "Subwoofer On." The front left, front right, center and rear speakers should all be set to "Small."

00334-3

Operation

OPERATION

Move the Master Power switch (marked "Power" ❶) to the "•" (On) position to use the subwoofer. The SCS135 subwoofer will automatically turn itself on or go into standby (sleep) mode when left in the standby mode ("Auto/On" switch ❷ in the "Auto" position). When your receiver or amplifier is off, or

is not sending program material to the subwoofer, the subwoofer will be in standby mode. When the subwoofer senses an audio signal, it will automatically turn itself on. If the subwoofer does not sense a signal after approximately twenty minutes, it will automatically go into standby mode.

When the "Auto/On" switch ❷ is switched to the "On" position, the subwoofer will remain on, whether or not program material is playing. If you will be away from home for an extended period of time, or if the subwoofer will not be used, switch the Master Power switch ❶ to the Off position.

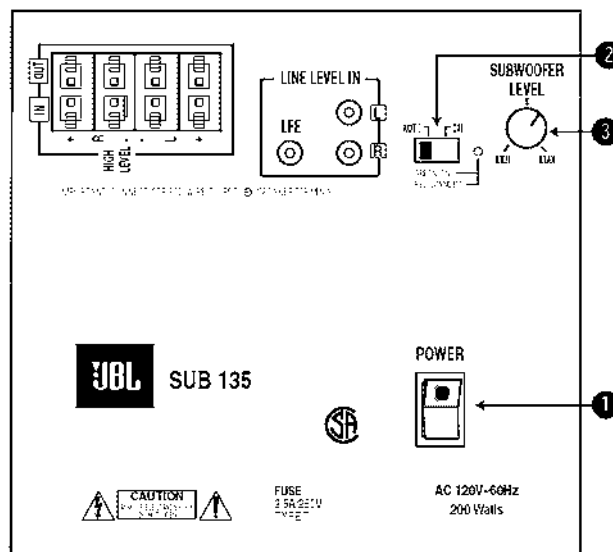

Volume

Volume can be adjusted using the Subwoofer Level Control ❸ (above), as shown below.

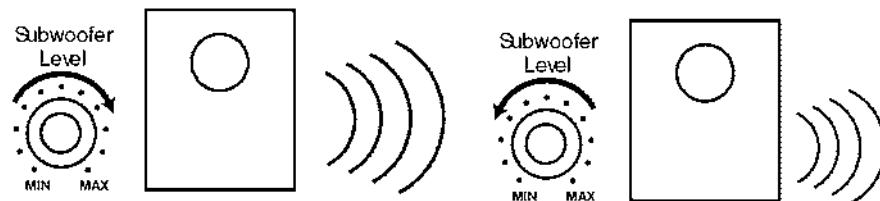

00344-4

Troubleshooting

TROUBLESHOOTING

If there is no sound from any of the speakers:

- Check that receiver/amplifier is on and a source is playing.
- Check that the powered subwoofer is plugged in, its Power switch ① is switched on to the "•" position, and the "Auto/On" switch ② is either in the "On" or "Auto" position.
- Check all wires and connections between receiver/amplifier and speakers. Make sure all wires are connected. Make sure none of the speaker wires are frayed, cut or punctured.
- Review proper operation of your receiver/amplifier.

If there is no sound coming from one speaker:

- Check the "Balance" control on your receiver/amplifier.
- Check all wires and connections between receiver/amplifier and speakers. Make sure all wires are connected. Make sure none of the speaker wires are frayed, cut or punctured.
- In Dolby Digital or DTS modes, make sure that the receiver/processor is configured so that the speaker in question is enabled.

If there is no sound from the center speaker:

- Check all wires and connections between receiver/amplifier and speaker. Make sure all wires are connected. Make sure none of the speaker wires are frayed, cut or punctured.

- If your receiver/processor is set in Dolby Pro Logic mode, make sure the center speaker is not in phantom mode.
- If your receiver/processor is set in Dolby Digital or DTS mode, make sure the receiver/processor is configured so that the center speaker is enabled.

If the system plays at low volumes but shuts off as volume is increased:

- Check all wires and connections between receiver/amplifier and speakers. Make sure all wires are connected. Make sure none of the speaker wires are frayed, cut or punctured.
- If more than one pair of main speakers is being used, check the minimum impedance requirements of your receiver/amplifier.

If there is low (or no) bass output:

- Make sure the connections to the left and right "Speaker Inputs" have the correct polarity (+ and -).
- Make sure the subwoofer is plugged into an active electrical outlet.
- Make sure the powered subwoofer is plugged in and is either in the "On" or "Auto" position.
- In Dolby Digital or DTS modes, make sure your receiver/processor is configured so that the subwoofer and LFE output are enabled.

If there is no sound from the surround speakers:

- Check all wires and connections between receiver/amplifier and speakers. Make sure all wires are connected. Make sure none of the speaker wires are frayed, cut or punctured.
- Review proper operation of your receiver/amplifier and its surround-sound features.
- Make sure the movie or TV show you are watching is recorded in a surround-sound mode. If it is not, check to see if your receiver/amplifier has other surround modes you may use.
- In Dolby Digital or DTS modes, make sure your receiver/processor is configured so that the surround speakers are enabled.
- Review the operation of your DVD player and the jacket of your DVD to make sure that the DVD features the desired Dolby Digital or DTS mode, and that you have properly selected that mode using both the DVD player's menu and the DVD disc's menu.

00344-5

Mechanical/Packaging Parts List

SUB135

Amplifier assembly	SCS135/SUB-01
8" 4 ohm woofer	20MF10PAG-DW02-01
Rubber foot	WI5216

135SAT

Satellite, Complete	SCS135/SAT-01
Front foot	WI5213
Rear foot	WI0782
Grille	G225000
Woofer	22PF48SA-DW01-01
Wall bracket	WI0408
Support mural	WI0409

135CEN

Center Channel, Complete	SCS135/CENTER
Grille	G225001
Woofer DCR = 3.4 ohms \pm 10%	22PF48SA-DW01-01

Packaging

Owner's manual	AI5073
Warranty card	AT0331
Survey card	AI0193
Outer carton	WG5164
Subwoofer styrofoam	WP5101
Wire set (Sub in/out)	SAL063-1
Wire set (sats & center)	SAL5009
Wire set (surround)	SAL5019

OPTIONAL: Floor Stands for 135SAT satellites - FS300

SUB135 Detailed Exploded View

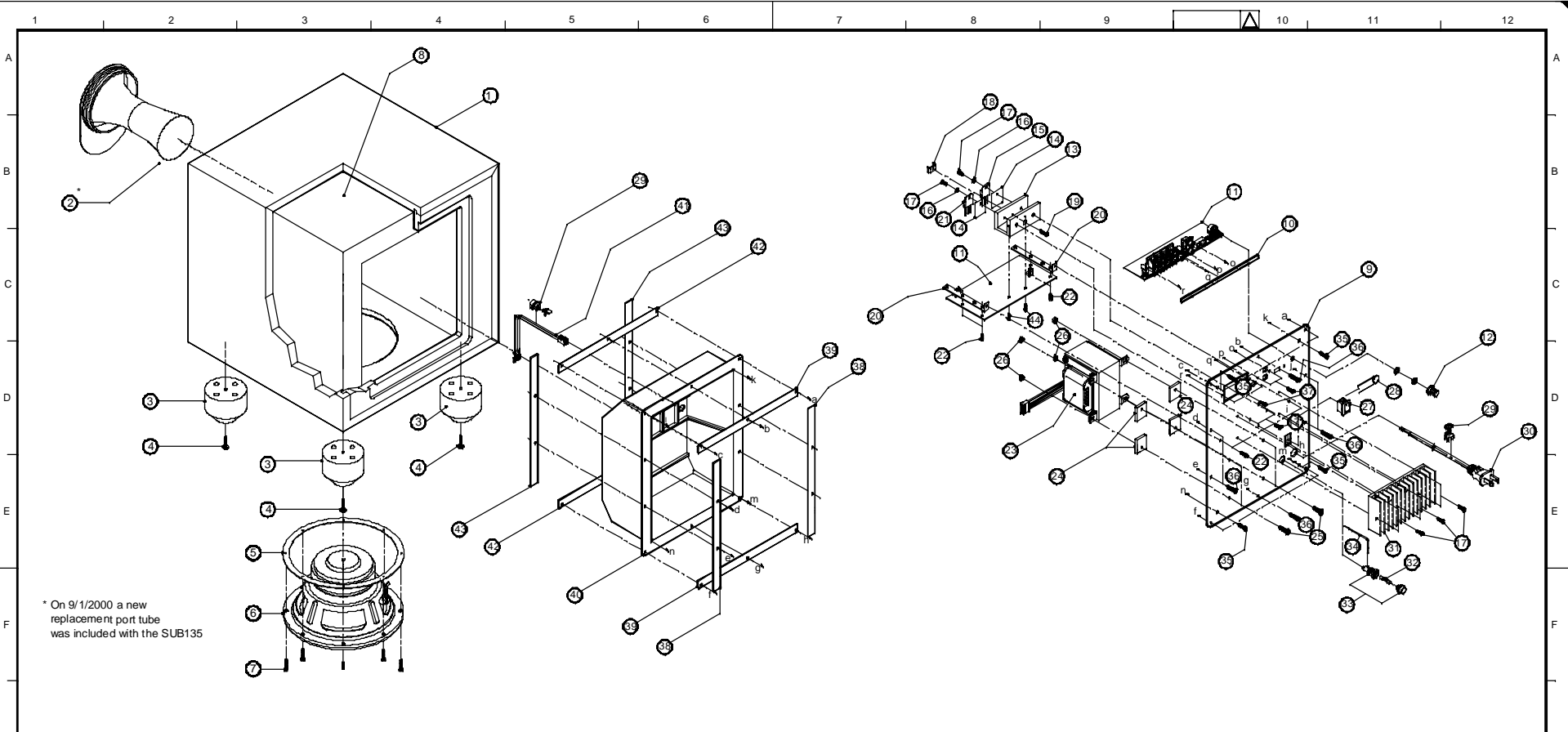

* On 9/1/2000 a new replacement port tube was included with the SUB135

REF.No.	PARTS No.	DESCRIPTION	Q'TY	REF.No.	PARTS No.	DESCRIPTION	Q'TY	REF.No.	PARTS No.	DESCRIPTION	Q'TY
1	N/A	EMPTY CABINET ASSEMBLY	1	16	712A130	SHOULDER WASHER (SW06002)	2	31	653HS135-1	HEAT SINK 117.5x60x25	1
2	N/A *	PORT TUBE	1	17	06-M30814	SCREW M3x8 TYPE TT	2	32	154U25006T0	FUSE 2.5A 250V 20mm	1
3	W15216	RUBBER FOOT	4	18	650LB800	BRACKET 14.2x8.0x5.2 t=1.6mm	1	33	155520020	FUSE HOLDER R3-11	1
4	06-T43005	WOOD SCREW Ø4x30	4	19	06-M31403	SCREW M3x14xP0.5 mm	1	34	16210082007	WIRE RED 18AWG 80mm	1
5	PA06001	SPEAKER EVA CUSHIOH 600x7x1t	1	20	650SUB240	PCB RRACKET L TYPE T=1.6mm A.P.C.C	2	35	06-T41208	WOOD SCREW 4x12mm	4
6	20MF10PAG-DW020	JBL 8" 35MM 4 Ω SUBWOOFER	1	21	192022TIP36C	TRANSISTOR TIP36C	1	36	06-T4205012	WOOD SCREW 14x20mm	10
7	06-T4205012	WOOD SCREW 4x20mm	8	22	06-M30809	SCREW M3x8xP0.5 TYPE C	4	37	06-T31004	SCREW M3x10mm	4
8	730A125	SOUND-ABSORBENT	1	23	150E8604107	TRANSFORMER E1-86 60Hz 120V TT0869906580	1	38	723A125-1	EVA CUSHIOH 213x15x1.0t	2
9	640RP135-1	REAR PANEL 215x270x2.5t	1	24	725A125	RUBBER CUSHIOH 25x21x4t	4	39	723B125-1	EVA CUSHIOH 238x15x1.0t	2
10	723D125	EVA CUSHION 170x5x1t	1	25	06-M41605	SCREW M4x16 TYPE TYPE C	4	40	700RC800A	REAR CABINET 268x213x102 A.B.S UL	1
11	1010SUB135	PRE. AMP./POWER AMP. P.C. BOARD	1	26	06-N4HW01	TOOTH LOCK WASHER FOR M4 NUTS	4	41	16210302001	SPEAKER WIRE UL1015 300mm	1
12	700KB800	SUB. LEVEL KNOB	1	27	180PBR12C11S	POWER PUSH SW. BR12C11S	1	42	723A125	EVA CUSHIOH 213x15x2.0t	2
13	653HS135-S	HEAT SINK 65x32x31 (ALUMINUM)	1	28	1302G472MD00	CERAMICS CAP. 4700P 400V ±20%	1	43	723B125	EVA CUSHIOH 238x15x2.0t	2
14	1933M2520	MICA	2	29	707AC800	CORD BUSHINHS	2	44	06-T30804	SCREW 3x8mm PAN TYPE C	2
15	192021TIP35C	TRANSISTOR TIP35C	1	30	152U602015	AC CORD SVT FT-2 6FT	1				

00335

Test Set Up and Procedure

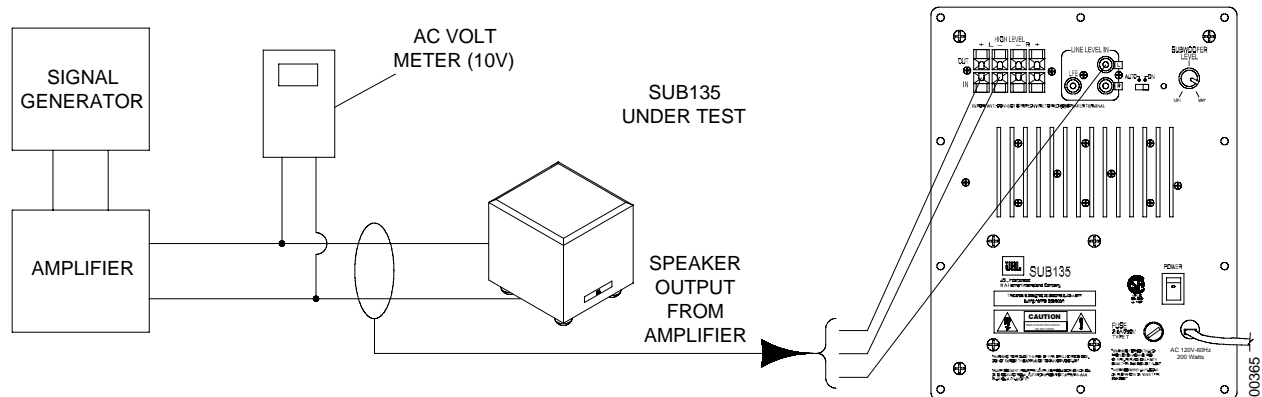

Equipment needed:

- Function/signal generator/sweep generator
- Integrated Amplifier
- Multimeter
- Speaker cables

General Unit Function (UUT = Unit Under Test)

- 1) From the signal generator, connect one line level (RCA) cable to the Subwoofer Line Level Input jacks L/R on the UUT. Use a Y-cable from a mono source if necessary to connect to both inputs. Do not connect to the single SUB input.
- 2) On the front of the unit, turn the LEVEL control full counterclockwise.
- 3) Turn on generator, adjust to **100mV, 50 Hz**.
- 4) Plug in UUT; turn the power switch ON. LED should be Red. Turn LEVEL control full clockwise (MAX)
- 5) LED should now be Green; immediate bass response should be heard and felt from port tube opening.
- 6) Turn off generator, turn VOLUME control fully counterclockwise, disconnect RCA cable.
- 7) Connect one pair of speaker cables to Speaker Level input terminal (IN) on UUT. Cables should be connected to an integrated amplifier fed by the signal generator.
- 8) Turn on generator and adjust so that speaker level input at the amplifier is **2.0V, 50 Hz**. Turn LEVEL control full clockwise.
- 9) Green LED should light, immediate bass response should be heard and felt from the port tube opening.

Sweep Function

- 1) Follow steps 7-9 above, using a sweep generator as a signal source.
- 2) Sweep generator from 20Hz to 300Hz. Listen to the cabinet and drivers for any rattles, clicks, buzzes or any other noises. If any unusual noises are heard, remove woofers and test.

Driver Function

- 1) Remove woofer from cabinet; detach + and - wire clips.
- 2) Check DC resistance of woofer; it should be **3.4 ohms ±10%**
- 3) Connect a pair of speaker cables to driver terminals. Cables should be connected to an integrated amplifier fed by a signal generator. Turn on generator and adjust so that speaker level output is **5.0V**.
- 4) Sweep generator from 20Hz to 1kHz. Listen to driver for any rubbing, buzzing, or other unusual noises.

Packaging

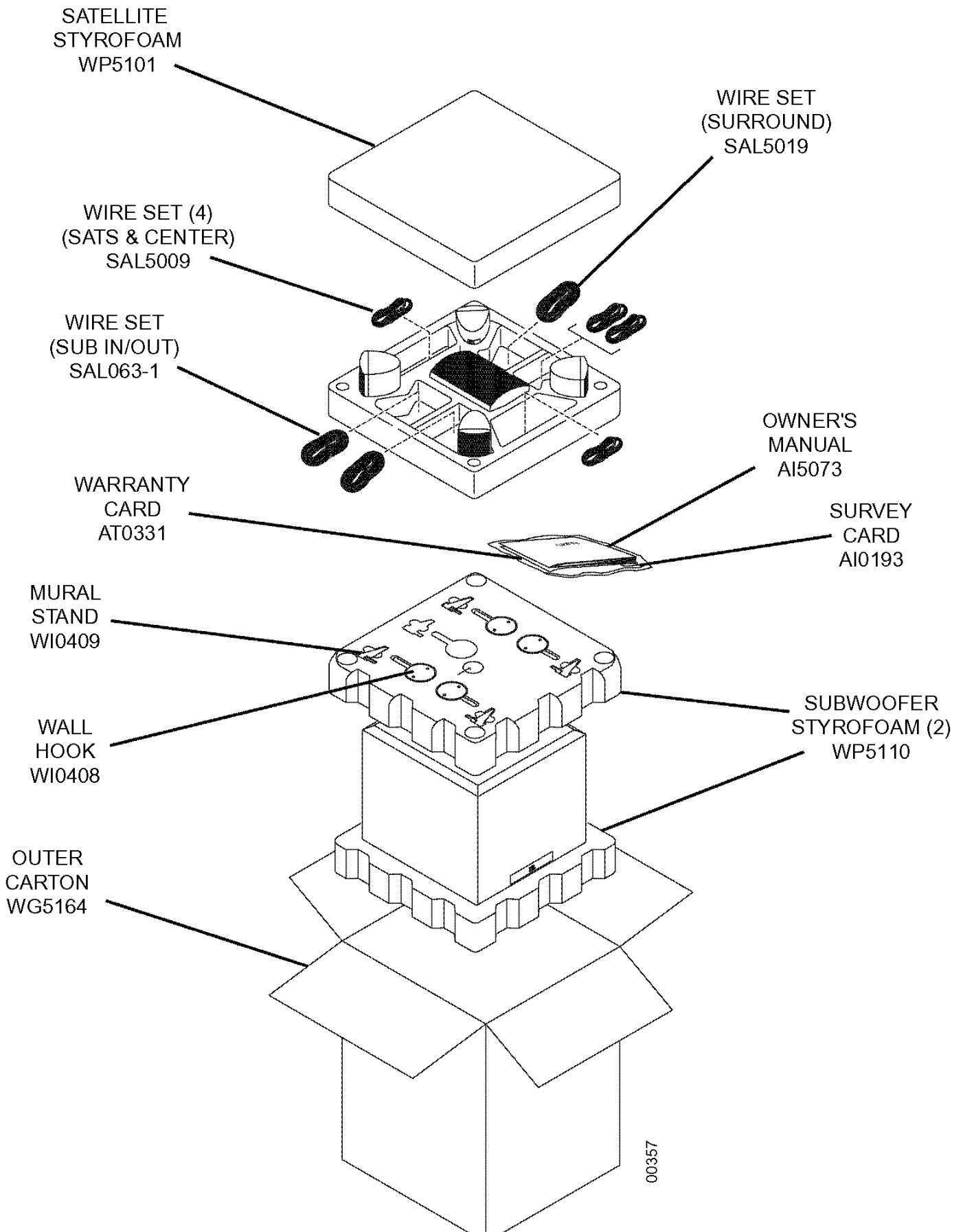

Electrical Parts List

Part No.	Description	Qty	Reference Designator
SEMICONDUCTORS			
197131n4148	DIODE 1N4148 26mm TAP	9	D101, 103, 105, 108, 201, 202, 206, 207, 208
19915000335	ZENER 3.3V 1/2W 26mm TAP	2	D102, 205
19915000625	ZENER 6.2V 1/2W 26mm TAP	2	D106, 107
19915001605	ZENER 16V 1/2W 26mm TAP	1	D109
19510204hgw	LED 204HGW	1	D209
19700kbl405	BD 4A 500V KBL405 BRIDGE	1	D110
197101n4002	DIODE 1N4002	1	D104
197101n4148	DIODE 1N4148	2	D301, 302
192027c1815gr	TR 2SC1815GR TAP	8	Q102, 111, 112, 113, 118, 206, 207, 208
192028a1015gr	TR 2SA1015GR TAP PNP	2	Q114, 116
1921672n5551	TR 2N5551 TAP NPN	2	Q103, 109
1921682n5401	TR 2N5401 AI-PNP 350V 500mA TO-92	2	Q104, 110
192021c1815gr	TR 2SC1815GR NPN	4	Q101, 115, 301, 302
192011d669a	TR 2SD669A NPN	1	Q106
192021tip35c	TR TIP35C NPN	1	Q107
192012b649a	TR 2SB649A PNP	1	Q105
192022tip36c	TR TIP36C PNP	1	Q108
192201d882y	TR KSD882Y PNP	1	Q117
192202b772y	TR KSB772Y PNP	1	Q119
19006m4558d	IC OPA 4558D QUAD OP-AMP	2	U101, 203
19016tl074cn	IC TL074CN ST QUAD OP-AMP	3	U201, 202, 301
RESISTORS			
11014122j26	RES 1.2K 1/4W 5% CF 26mm TAP	1	R265
11014472j26	RES 4.7K 1/4W 5% CF 26mm TAP	4	R147,150,201,202
11014681j26	RES 680 1/4W 5% CF 26mm TAP	2	R148,151
11016101j26	RES 100 1/6W 5% CF 26mm TAP	4	R120,213,214,215
11016102j26	RES 1K 1/6W 5% CF 26mm TAP	2	R124,254
11016103j26	RES 10K 1/6W 5% CF26mmTAP	23	R134, R134,209,212, 216, 217, 220, 221, 228, 229, 230, 232, 235, 240, 260, 264, 301, 302, 303, 304, 308, 309, 314
11016104j26	RES 100K 1/6W 5% CF 26mm TAP	1	R231
11016105j26	RES 1M 1/6W 5% CF 26mm TAP	2	R143, 259
11016123j26	RES 12K 1/6W 5% CF 26mm TAP	2	R135, 139
11016124j26	RES 120K 1/6W 5% CF 26mm TAP	1	R233
11016151j26	RES150 1/6W 5% CF 26mm TAP	1	R253

Electrical Parts List

Part No.	Description	Qty	Reference Designator
11016152j26	RES 1.5K 1/6W 5% CF 26mm TAP	6	R103, 123, 136, 137, 141, 142
11016153j26	RES 15K 1/6W 5% CF 26mm TAP	5	R118, 145, 152, 154, 234
11016154j26	RES 150K 1/6W 5% CF 26mm TAP	2	R131, 252
11016181j26	RES 180 1/6W 5% CF 26mm TAP	2	R111, 114
11016182j26	RES 1.8K 1/6W 5% CF 26mm TAP	1	R153
11016183j26	RES 18K 1/6W 5% CF 26mm TAP	2	R227, 262
11016223j26	RES 22K 1/6W 5% CF 26mm TAP	10	R128, 129, 133, 237, 238, 255, 256, 263, 310, 312
11016273j26	RES 27K 1/6W 5% CF 26mm TAP	1	R223
11016205j26	RES 2M 1/6W 5% CF 26mm TAP	1	R257
11016332j26	RES 3.3K 1/6W 5% CF 26mm TAP	5	R106, 107, 144, 236, 258
11016333j26	RES 33K 1/6W 5% CF 26mm TAP	1	R305
11016392j26	RES 3.9K 1/6W 5% CF 26mm TAP	2	R105, 108
11016393j26	RES 39K 1/6W 5% CF 26mm TAP	1	R126
11016470j26	RES 47 1/6W 5% CF 26mm TAP	4	R112, 113, 115, 116
11016471j26	RES 470 1/6W 5% CF 26mm TAP	1	R140
11016472j26	RES 4.7K 1/6W 5% CF 26mm TAP	5	R110, 125, 130, 207, 208
11016473j26	RES 47K 1/6W 5% CF 26mm TAP	5	R101, 219, 249, 250, 251
11016474j26	RES 470K 1/6W 5% CF 26mm TAP	1	R307
11016512j26	RES 5.1K 1/6W 5% CF 26mm TAP	2	R210, 211
11016513j26	RES 51K 1/6W 5% CF 26mm TAP	1	R224
11016560j26	RES 56 1/6W 5% CF 26mm TAP	1	R117
11016563j26	RES 56K 1/6W 5% CF 26mm TAP	1	R104
11016682j26	RES 6.8K 1/6W 5% CF 26mm TAP	1	R109
11016751j26	RES 750 1/6W 5% CF 26mm TAP	2	R311, 313
11016755j26	RES 7.5M 1/6W 5% CF 26mm TAP	1	R306
11016913j26	RES 91K 1/6W 5% CF 26mm TAP	4	R203, 204, 205, 206
11010821jk1	RES 820 1W 5% 5mm	1	R132
110122r2j15	RES 2.2 1/2W 5% 15mm	1	R127
11020331jk2	RES 330 2W 5% 5mm	2	R146, 149
113500r1j10	RES 0.1 5W 5% 1	2	R121, 2
11403302m0	SVR 3K 0.3W 20%	1	R138
115h503a101	VR D16 50K/1 A VOLUME CONTROL	1	VR201

CAPACITORS

1302G472MD00	CERAMICS CAP. 4700P 400V \pm 20%	1	ON POWER SWITCH
1302b101k503	CD 100P 50V 10% TAP	3	C207, 214, 220
1302b102k503	CD 1000P 50V 10% TAP	2	C116, 203

Electrical Parts List

Part No.	Description	Qty	Reference Designator
1302b221k503	CD 220P 50V 10% TAP	6	C204, 205, 210, 211, 212, 230
1302b681k503	CD 680P 50V 10% TAP	1	C208
1302f104z503	CD 0.1U 50V +80/-20% TAP	13	C108, 113, 115, 119, 232, 235, 236, 237, 239, 240, 241, 305, 306
1303f473m503	CD 0.047U 50V 20% TAP	2	C106, 209
130sl470k503	CD 47P 50V 10% TAP	1	1C229
132103j503	MC 0.01U 50V 5% TAP	2	C223, 224
132104j503	MC 0.1U 50V 5% TAP	4	C107, 218, 221, 222
132223ja03	MC 0.022U 100V 5% TAP	5	C124, 125, 126, 128, 215
132473j503	MC 0.047U 50V 5% TAP	2	C216, 217
132103j503	MC 0.01U 50V 5% TAP	2	C302, 305
1353105m50	EC 1U 50V 20% TAP	3	C105, 112, 228
1353106m50	EC 10U 50V 20% TAP	6	C201, 202, 206, 213, 219, 231
1353107m16	EC 100U 16V 20% TAP	6	C109, 117, 120, 234, 238, 242
1353226m50	EC 22U 50V 20% TAP	4	C114, 118, 225, 301
1353227m10	EC 220U 10V 20% TAP	2	C129, 130
1353227m16	EC 220U 16V 20% TAP	2	C111, 233
1353476m25	EC 47U 25V 20% TAP	2	C103, 304
132223ja04	MC 0.022U 100V 5%	2	C123, 127
1354107m16	EC 100U 16V 20%	1	C110
1354688m50	EC 6800U 50V 20% D25X45mm	2	C121, 122
MISCELLANEOUS			
180tms7210v	SW210 AUTO/ON SLIDE SWITCH		
156b010010	TUBE 1*10mm	2	Q101, 115
1740rcb202v	RCA JACK RCB-202V	1	JK202
1740rcb242v1	JACK RCA RCB-242V-1	1	JK203
171udhss124d	RELAY 5A 24V UDH-SS124D	1	RY101
1742rsp108v	8PIN SPK JACK RSP-108V	1	JK201
1933m2520	ISLATOR MICA TO-3P 25*20mm	2	Q107, 108
180PBR12C11S	POWER PUSH SW. BR12C11S	1	
152U602015	AC CORD SVT FT-2 6FT	1	
155520020	FUSE HOLDER R3-11	1	
154U25006T0	FUSE 2.5A 250V 20mm	1	
700KB800	SUB. LEVEL KNOB	1	
150E8604107	TRANSFORMER EI-86 60HZ 120V TT0869906580	1	

Integrated Circuit Diagrams

4558 DUAL OP AMP,
U101, 203

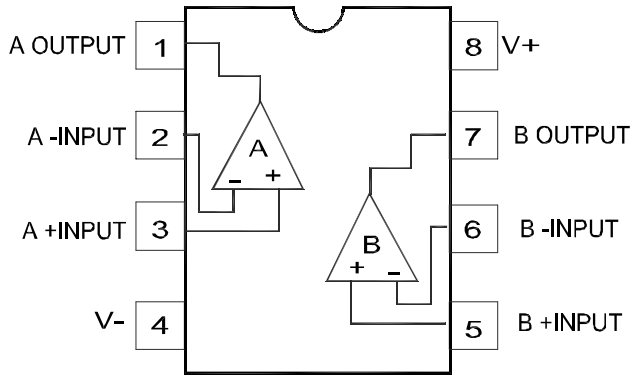

OPAMP, QUAD 14P DIL TL074
U201, 202, 301

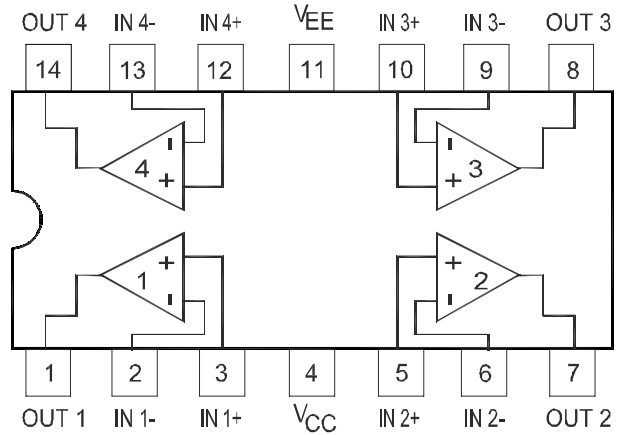

TIP35C NPN,
TIP36C PNP,
Q107,108

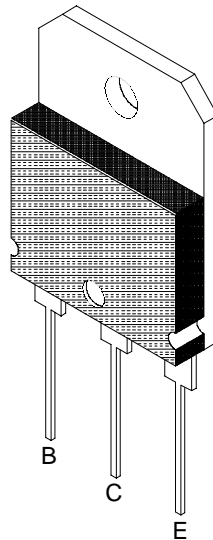

TRANS, PNP, 2N5401 TAP,
TO-92,
Q104,110

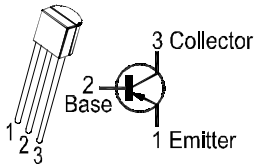

TRANS, NPN, 2N5551 TAP,
Q103,109

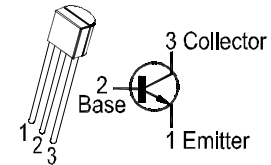

TRANS, PNP, TAP,
2SA1015GR, 2SB649A,
KSD882Y, KSB772Y
Q114,116,105,117,119

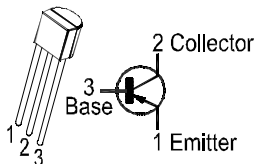

TRANS, NPN, 2SC1815GR TAP,
Q102,111,112,113,118,206,
207,208

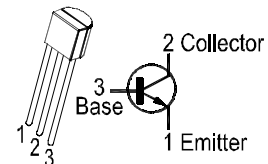

00340-1

PCB

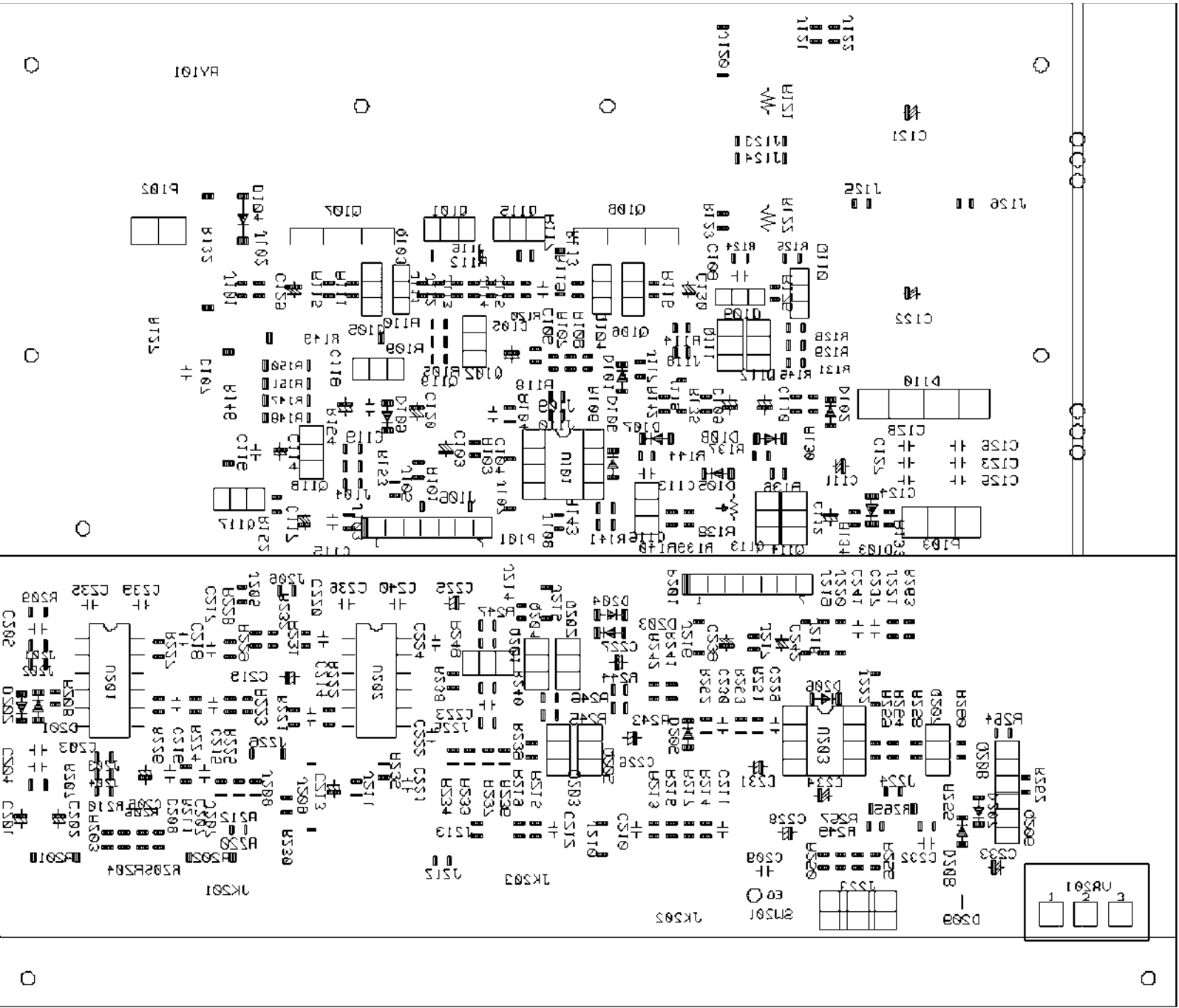

PCB

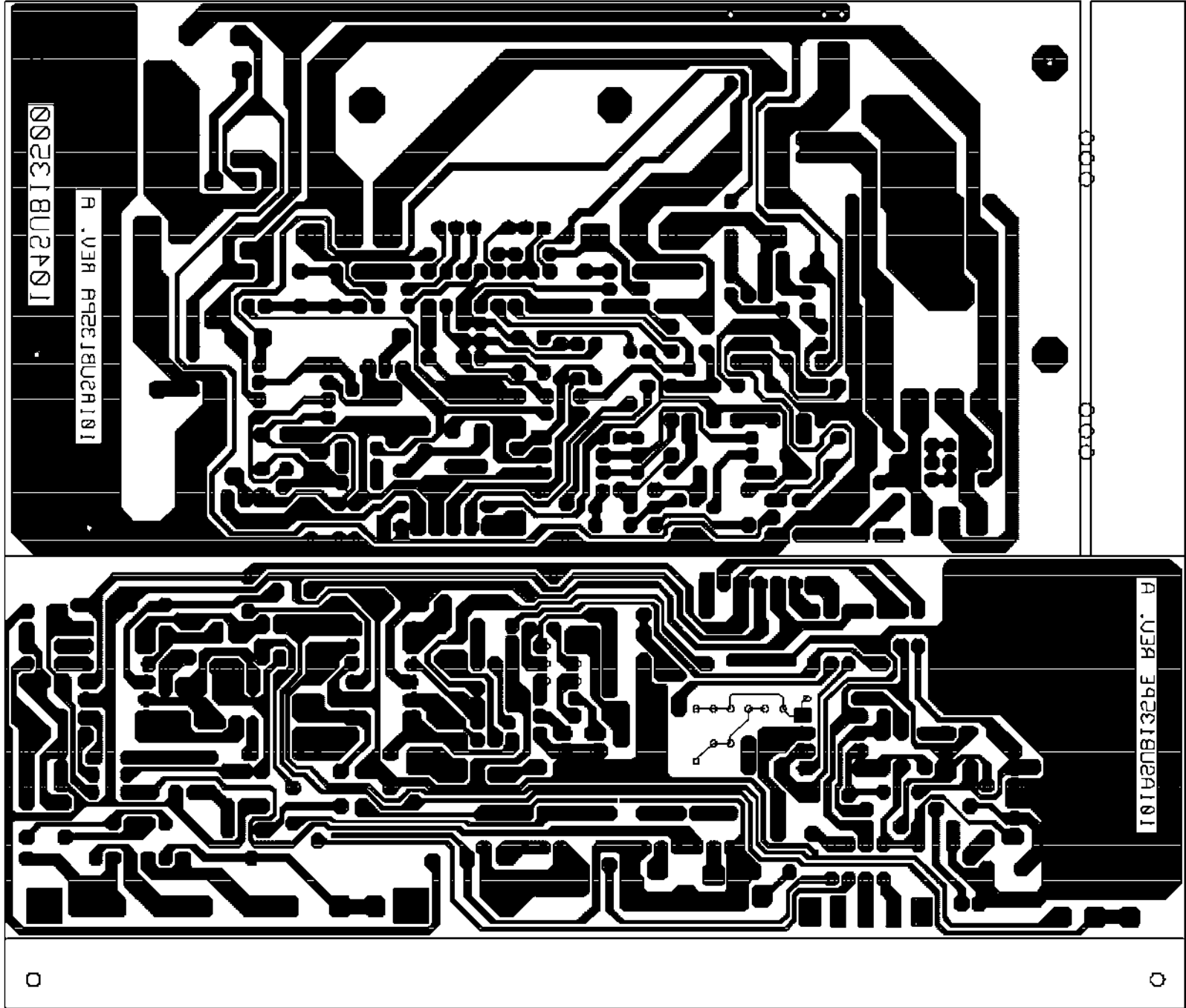

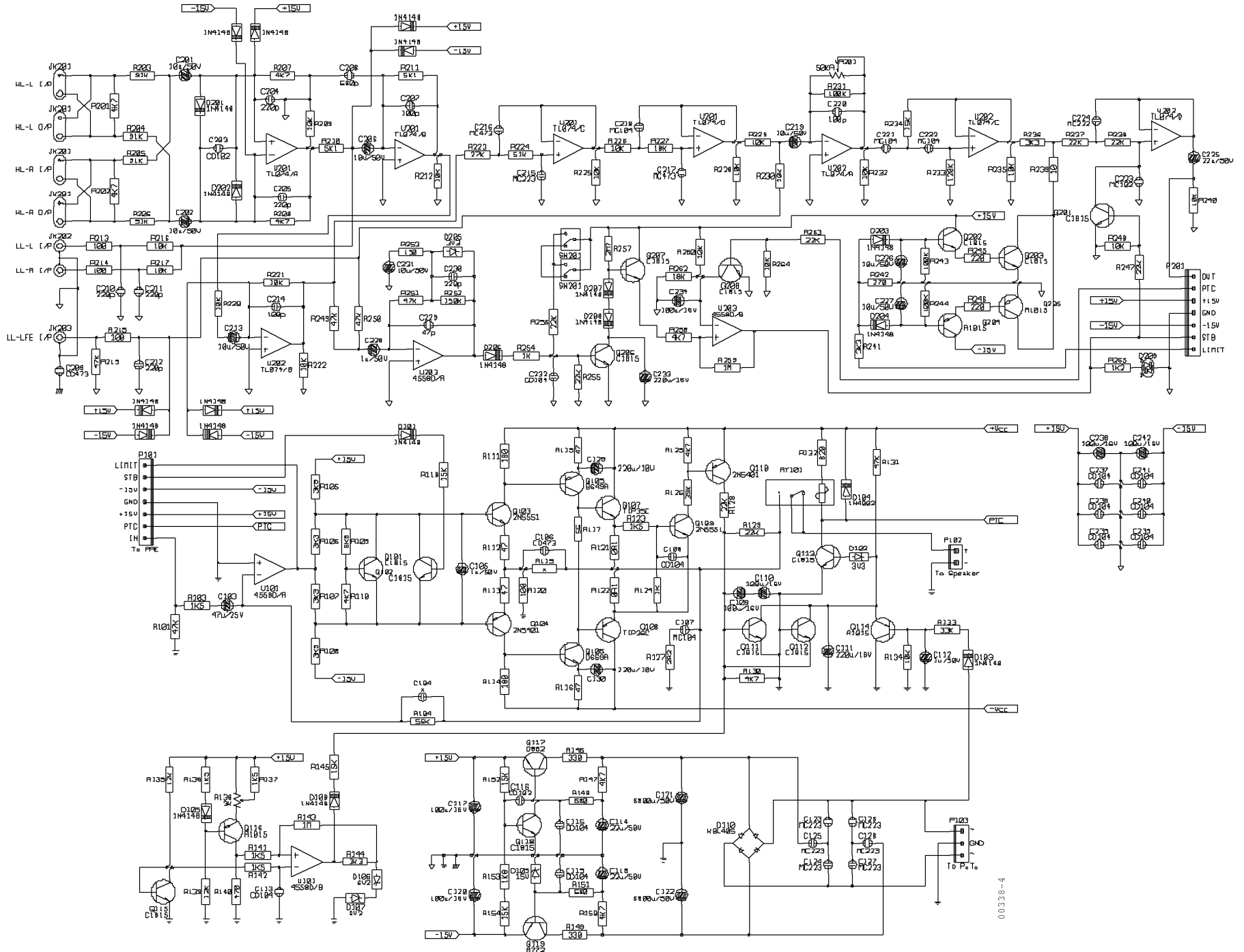

000338-4