

**CM-6
MAR-18-96**

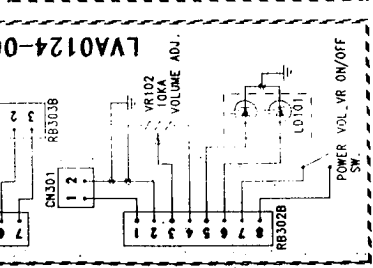
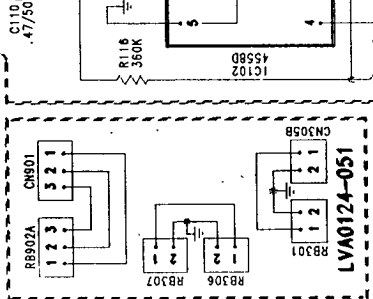
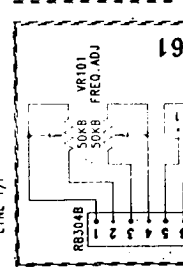
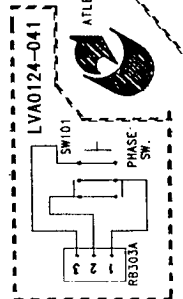
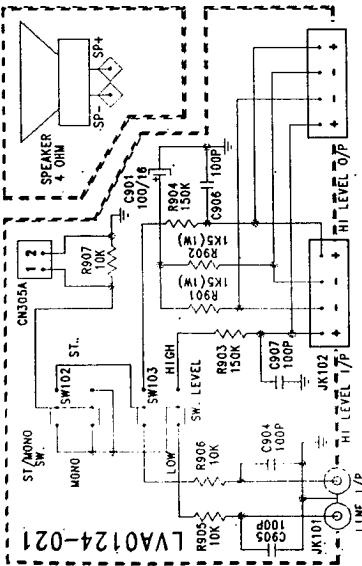
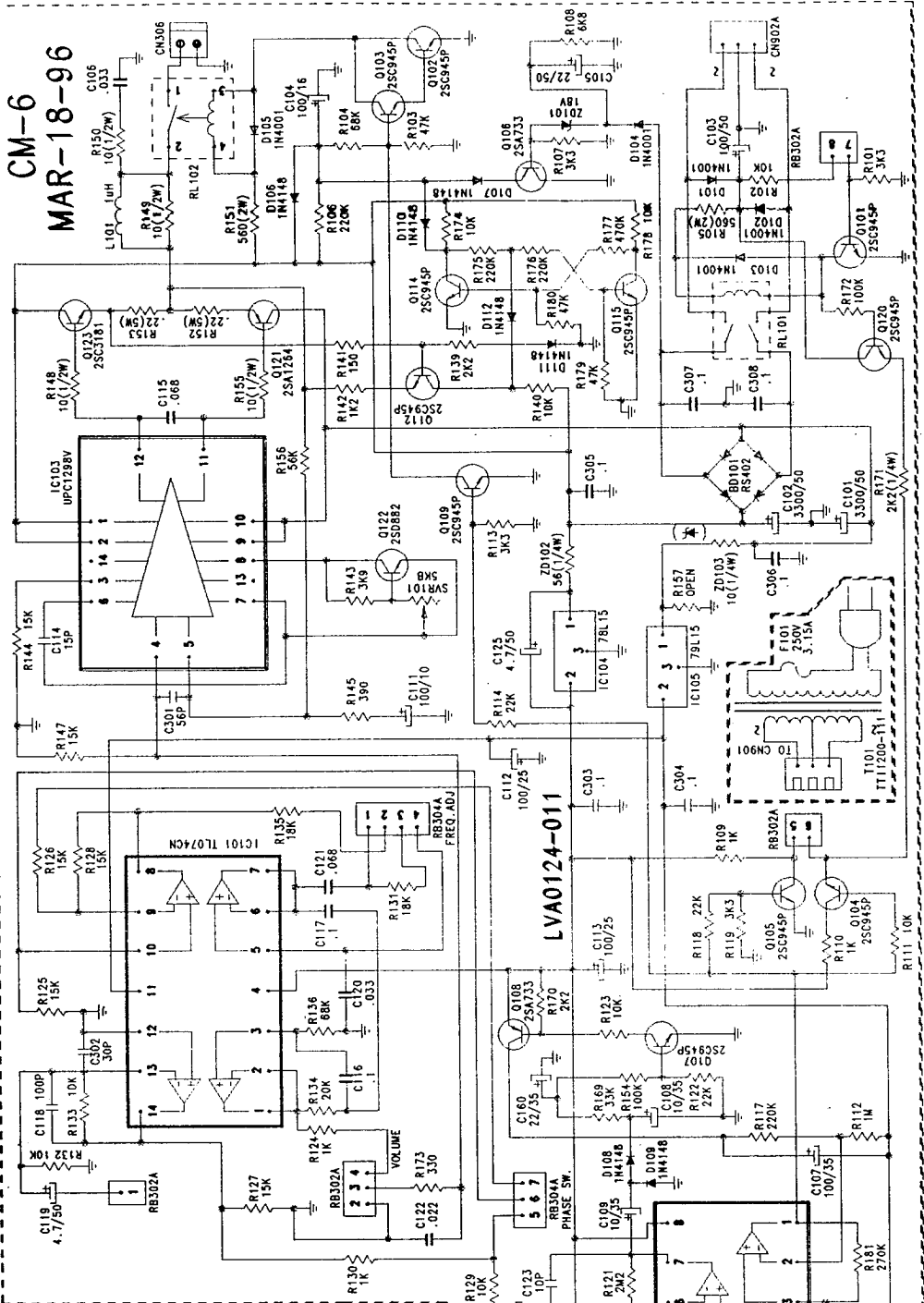

MODEL SCHEMATIC

MODEL: SUB-6/SUB-10

DESIGN BY: ATLE
DATE PRINTED: MAY-06-1996

CHECK BY: H. H. CHAO
PART NUMBER:

APPROVED BY: H. L. LEE
DWG. SIZE: LETTER
REVISION: L

PCAD FILE NAME:

CM-10 DISCREPANCY SHEET

LOCATION	DESCRIPTION	LOCATION	DESCRIPTION
0123	25C945P	ZD03	ZD 15V
0121	25A1265	C101/C102	560 OHM/1W
ZD01	ZD 24V	R107	4700uF/63V
R157	10K OHM	TTK1200-003	TTK1200-003
R135	160K OHM	F101	1A/250V

X' FORMER DISCREPANCY SHEET

FORMER	DESCRIPTION	FORMER	DESCRIPTION
CM-6	CM-10	TT11000-001	TTK1000-001
AC 100V	TT11200-111	TTK1200-003	TTK1200-003
AC 120V	TT12300-108	TTK2300-001	TTK2300-001

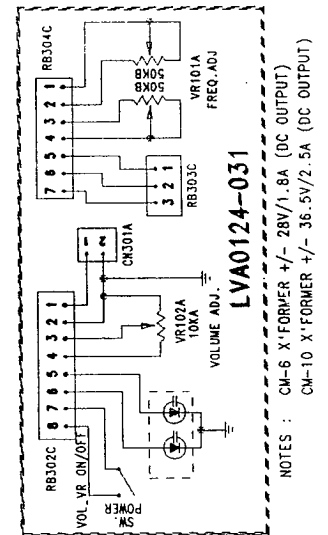

NOTES : CM-6 X'FORMER +/- 28V/1.8A (DC OUTPUT)
CM-10 X'FORMER +/- 36.5V/2.5A (DC OUTPUT)

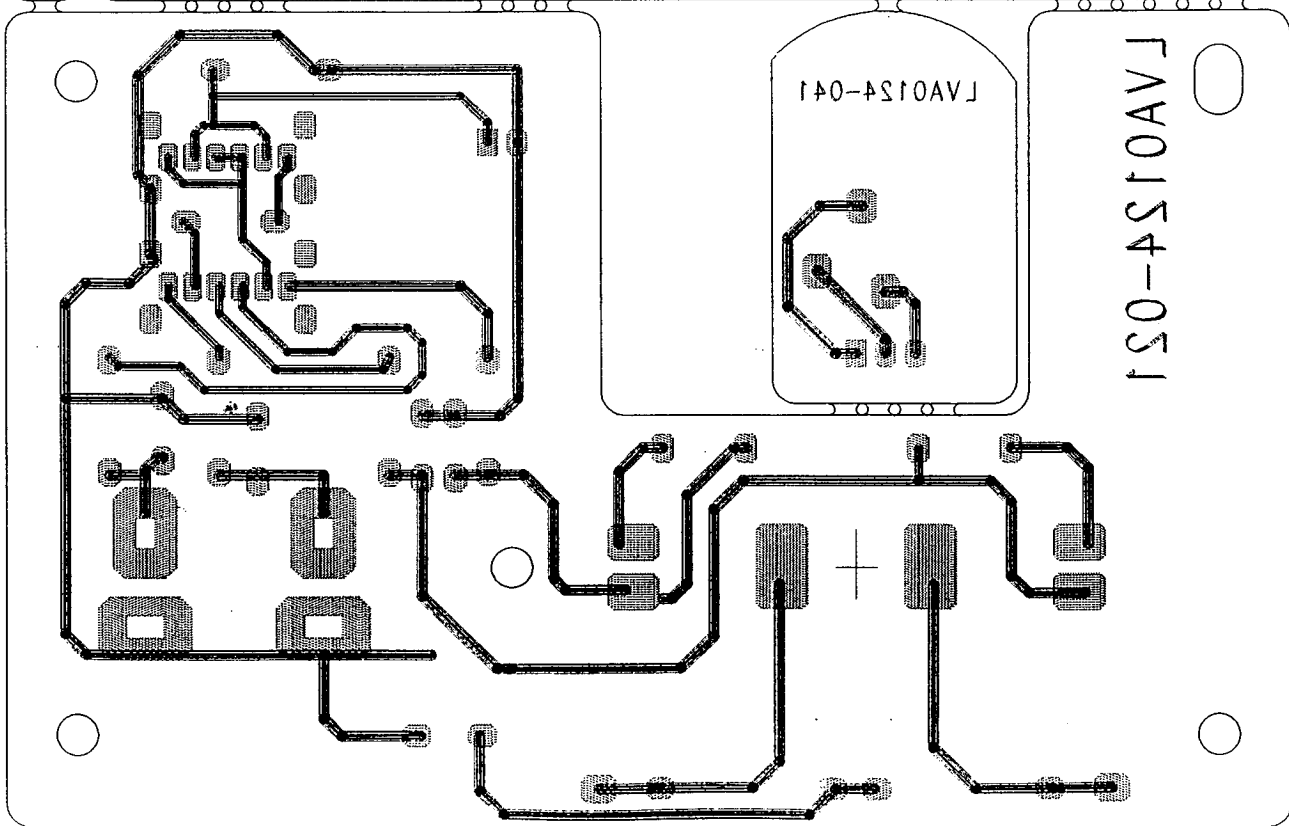
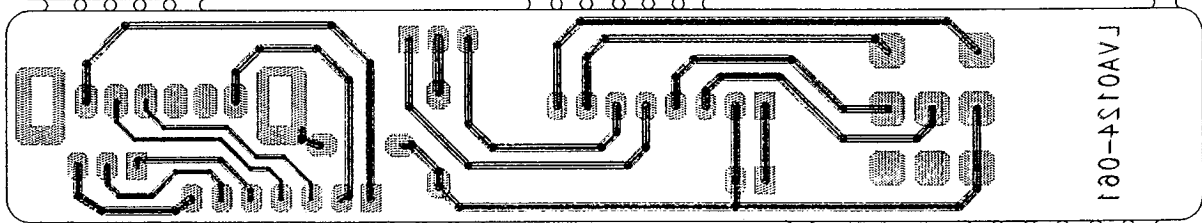
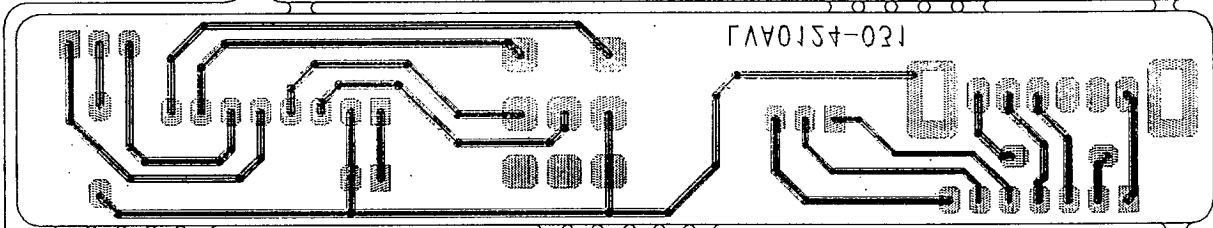
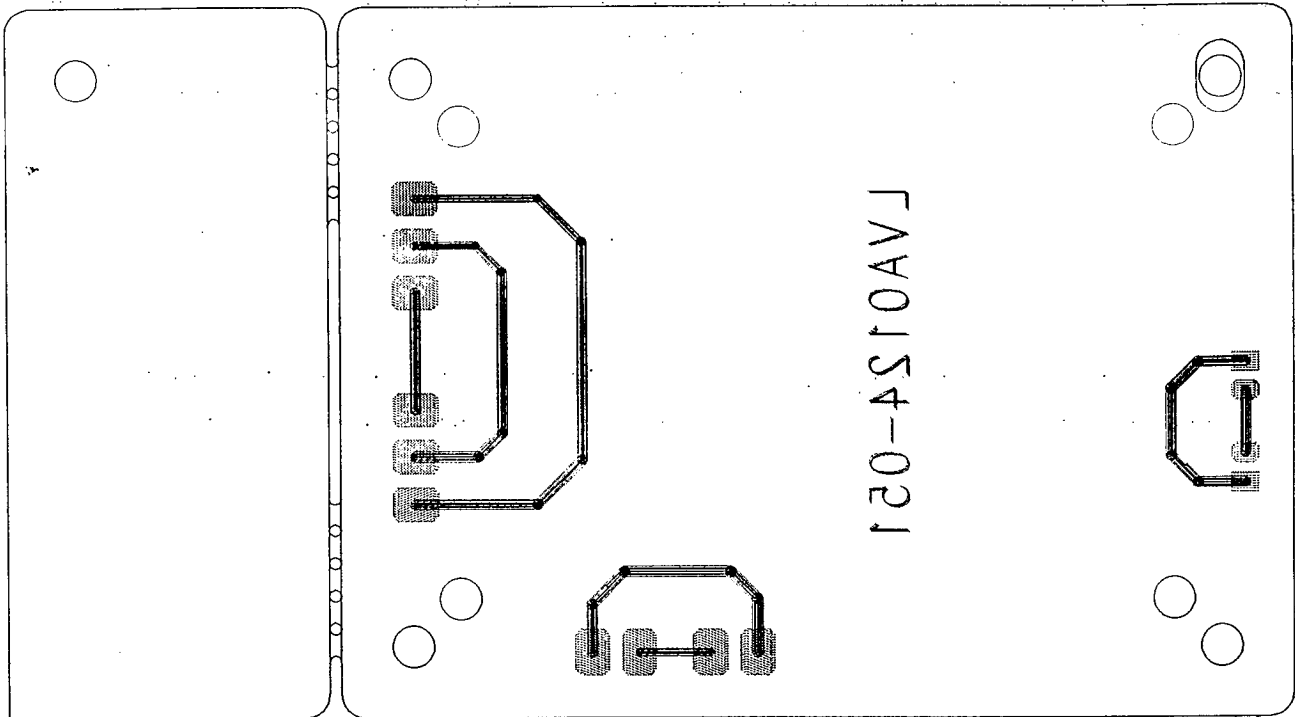

J10-4S10AVJ

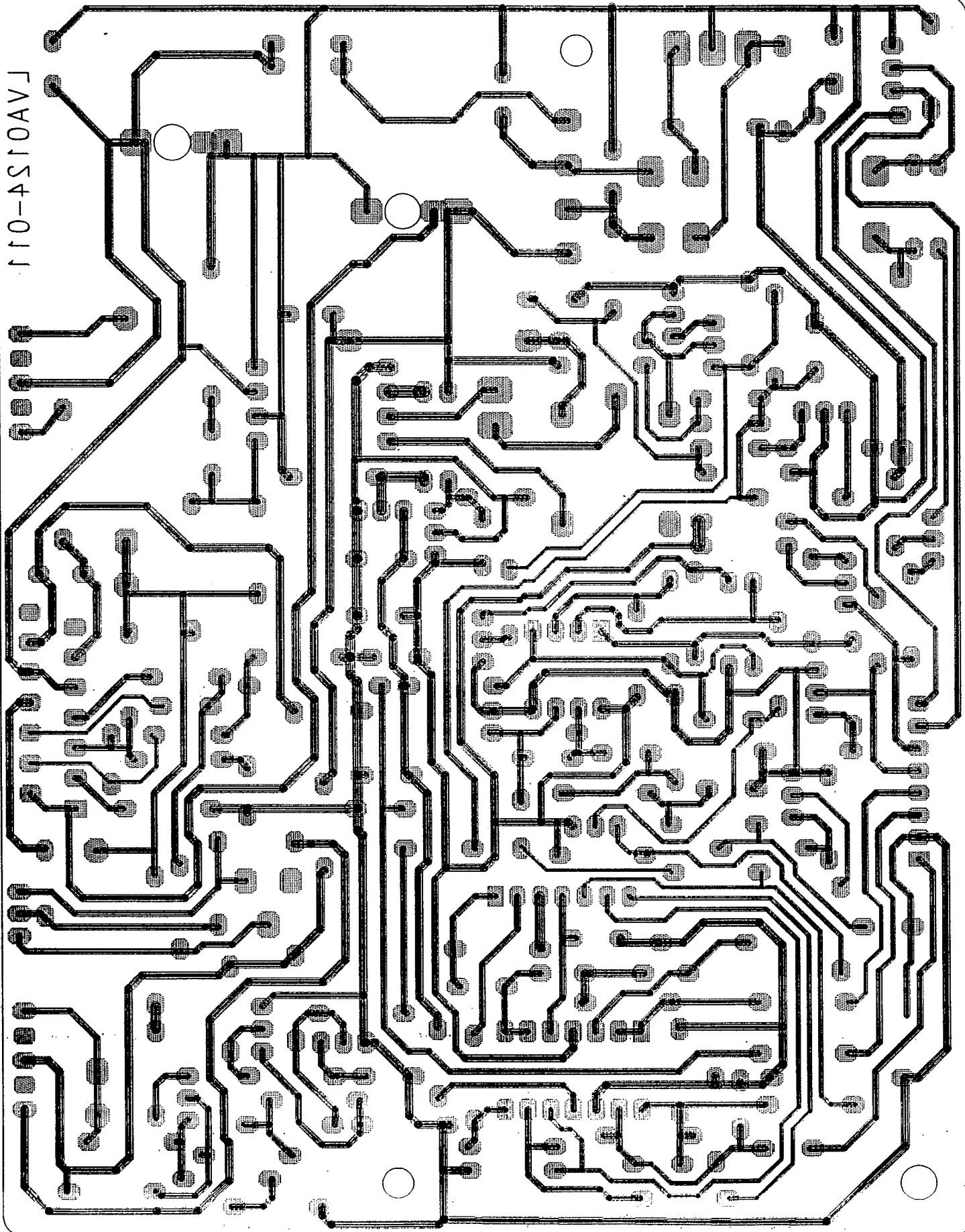

Sub 6 / SUB 10

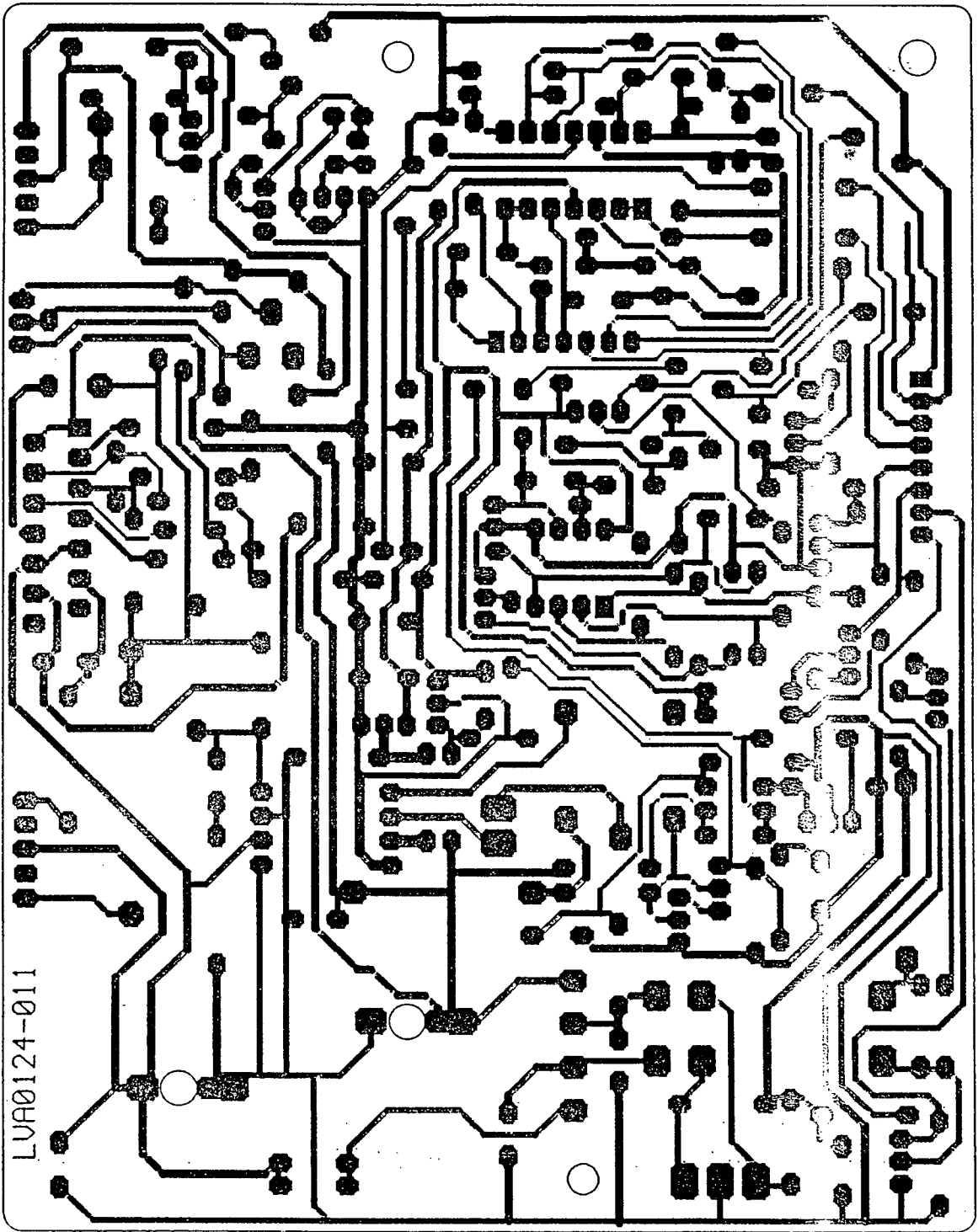

Sub 6 / Sub 10

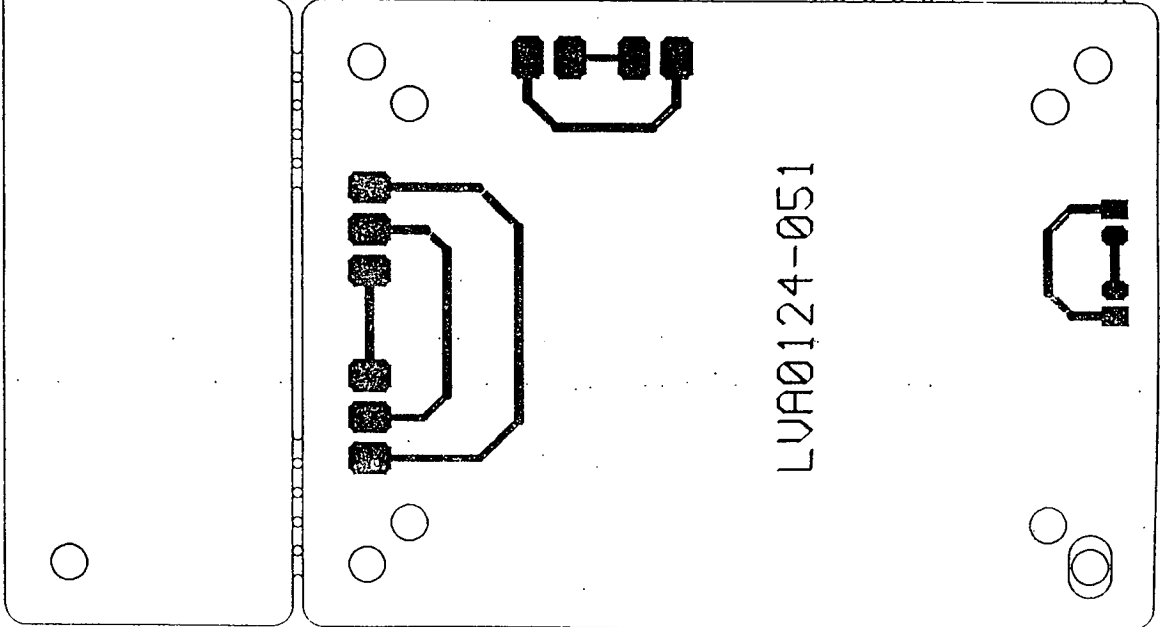
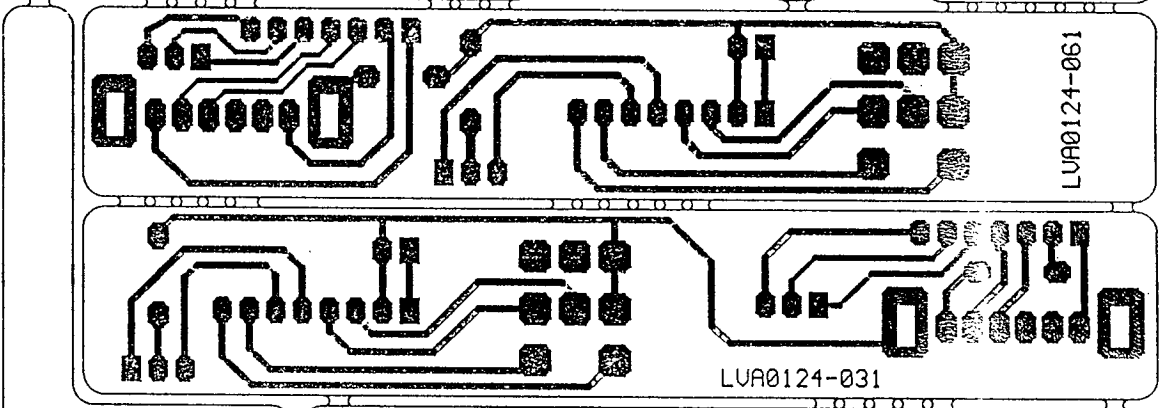
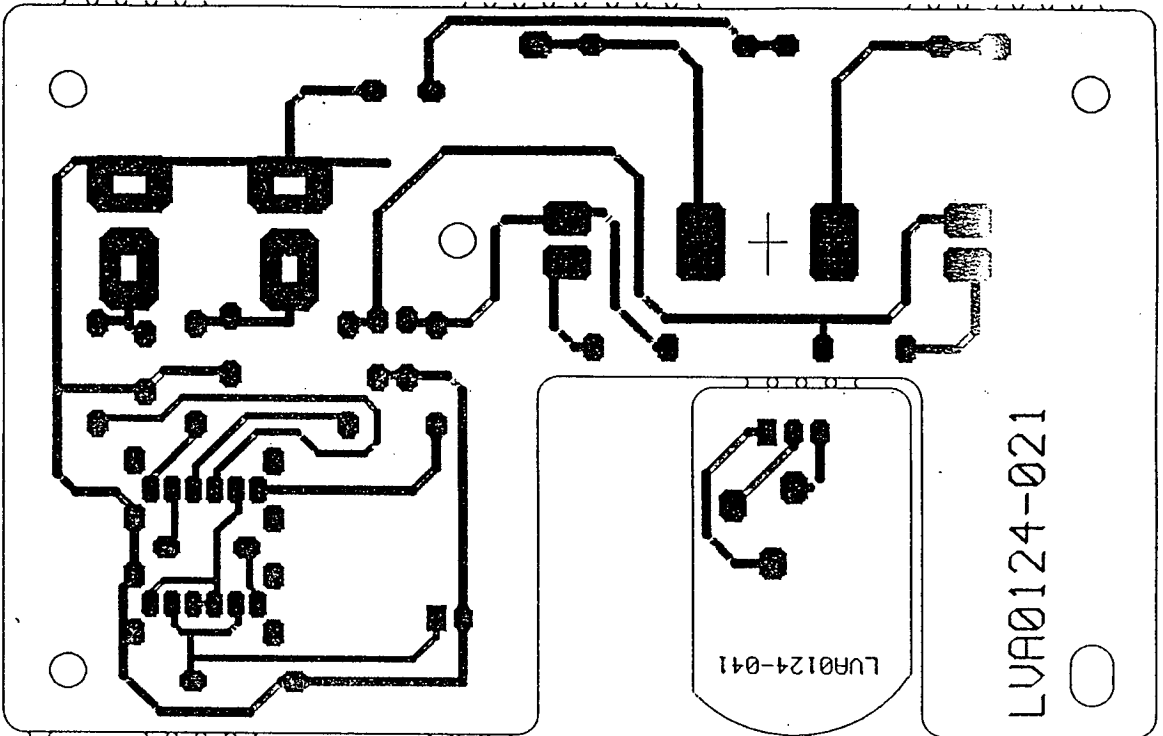

BLOCK DIAGRAM (SUB6/SUB10)

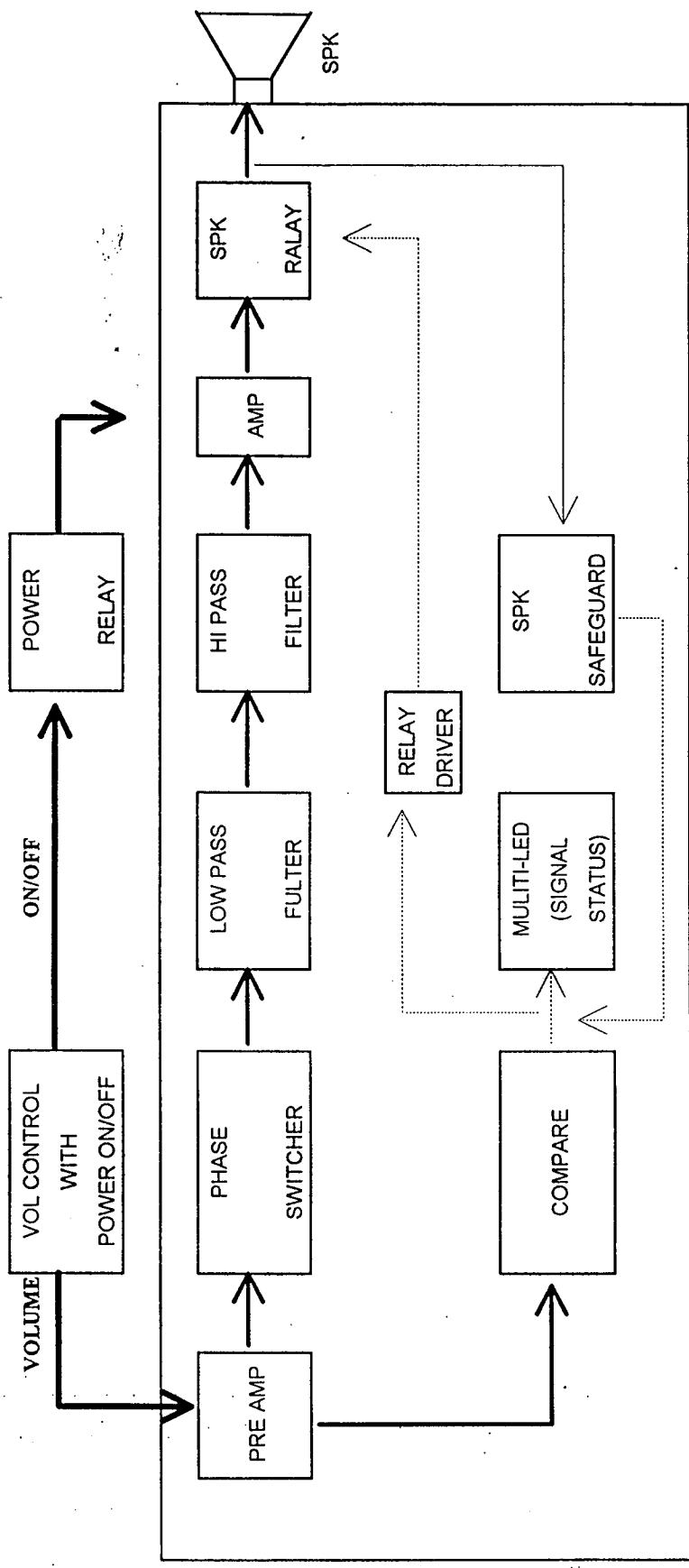

Sub 6 EXPLODED VIEW

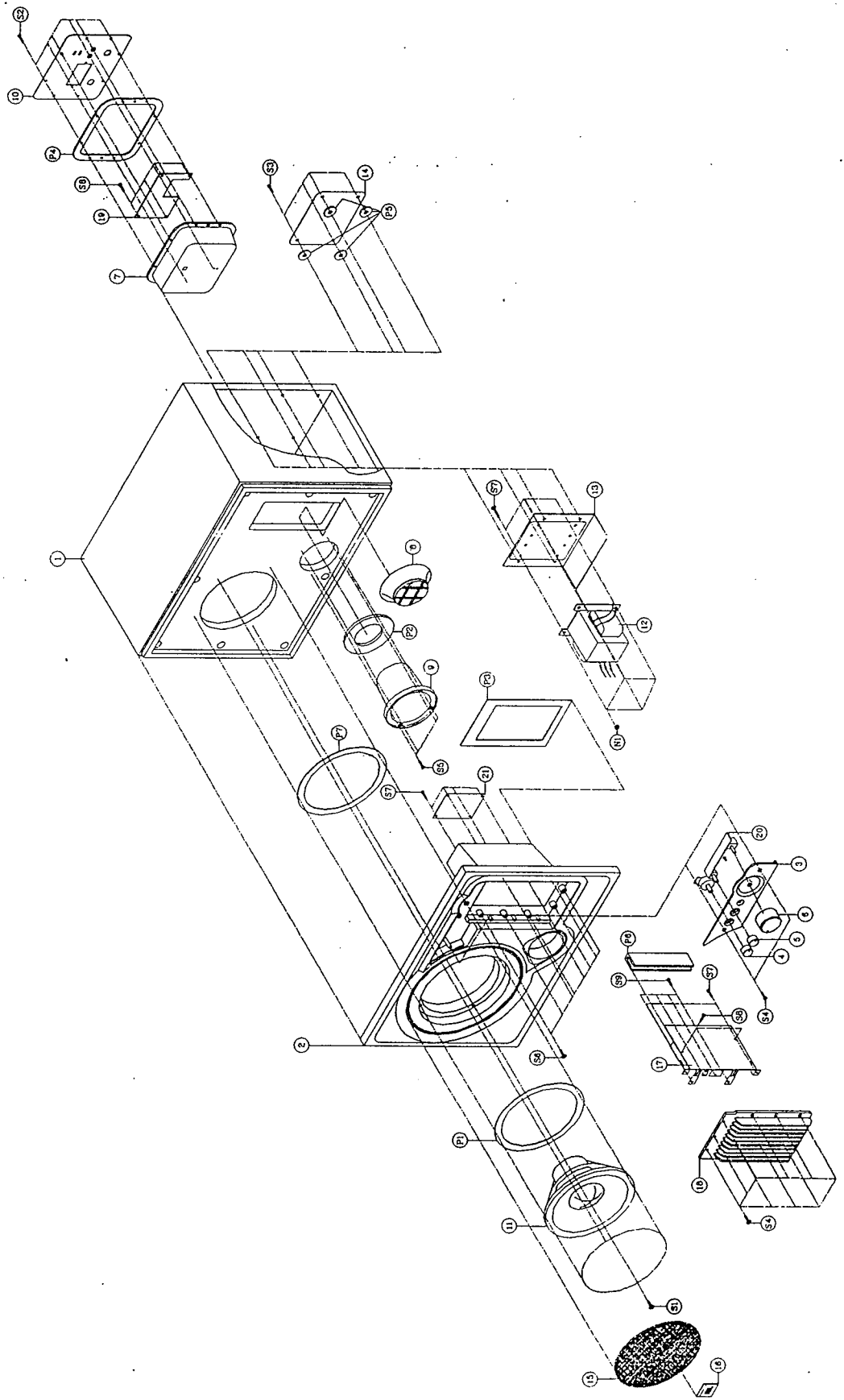

ARTS LIST

SUBB

DESCRIP. UN						REM
PACITORS						
C101-C102	COND ELECT	3300 uF	63 V	20 %	PVE3955-332	1.570
C103	COND ELECT	100 uF	50 V	20 %	PRE3955-101	0.060
C104	COND ELECT	100 uF	16 V	20 %	PRE3952-101	0.050
C105	COND ELECT	22 uF	50 V	20 %	PRE3955-220	0.050
C106	COND MYLAR	0.033 uF	100 V	5 %	PRM3737-333	0.030
C107	COND ELECT	100 uF	35 V	20 %	PRE3954-101	0.060
C108-C109	COND ELECT	10 uF	35 V	20 %	PRE3954-100	0.030
C110	COND ELECT	0.47 uF	50 V	20 %	PRE3955-478	0.030
C111	COND ELECT	100 uF	10 V	20 %	PRE3951-101	0.030
C112-C113	COND ELECT	100 uF	25 V	20 %	PRE3953-101	0.060
C114	COND DISC	15 pF	50 V	5 %	PRD1335-150	0.015
C115	COND MYLAR	0.068 uF	100 V	5 %	PRM3737-683	0.050
C116-C117	COND MYLAR	0.1 uF	100 V	5 %	PRE3737-104	0.060
C118	COND DISC	100 pF	50 V	5 %	PRD8035-101	0.015
C119	COND ELECT	4.7 uF	50 V	20 %	PRE3955-479	0.030
C120	COND MYLAR	0.033 uF	100 V	5 %	PRM3737-333	0.030
C121	COND MYLAR	0.068 uF	100 V	5 %	PRM3737-683	0.050
C122	COND MYLAR	0.022 uF	100 V	5 %	PRM3737-223	0.030
C123	COND DISC	10 pF	50 V	5 %	PRD8035-100	0.015
C125	COND ELECT	4.7 uF	50 V	20 %	PRE3955-479	0.030
C160	COND ELECT	22 uF	35 V	20 %	PRE3954-220	0.030
C301	COND DISC	56 pF	50 V	5 %	PRD8035-560	0.015
C302	COND DISC	30 pF	50 V	5 %	PRD8035-300	0.015
C303-C304	COND DISC	0.1 uF	50 V	+80-20 %	PRD3965-104	0.030
C305-C308	COND MYLAR	0.1 uF	100 V	5 %	PRM3737-104	0.060
CONNECTORS						
CN306	2 PIN	3951	POST BASE TOP	✓	CCN3951-002	0.040
CN902A	3 PIN	3951	POST BASE TOP	✓	CCN3951-003	0.050
DIODES						
BD101	RECTIFIER	RS402L		✓	RHD0402-001	0.570
D101-105	RECTIFIER	1N4001		✓	RAD4001-001	0.020
D106-D112	DIODE SW	1N4148		✓	RAD4148-001	0.010
ZD101	DIODE ZENER	17.5-18.3V		✓	RAZ0859-086	0.040
ICS						
IC101	14 PIN	TL074CN		✓	RHI0740-001	1.000
IC102	8 PIN	JRC4558D		✓	RHI4558-001	0.240
IC103	14 PIN	uPC1298V		✓	RHI1298-001	3.570
IC104	3 PIN	78L15		✓	RHI7815-002	0.285
IC105	3 PIN	79L15		✓	RHI7915-002	0.285
TRANSISTORS						
Q101-Q105	NPN	2SC945P		✓	RAN0945-001	0.040
Q106	PNP	2SA733R		✓	RAP0733-001	0.040
Q107	NPN	2SC945P		✓	RAN0945-001	0.040
Q108	PNP	2SA733R		✓	RAP0733-001	0.040
Q109	NPN	2SC945P		✓	RAN0945-001	0.040
Q112	NPN	2SC945P		✓	RAN0945-001	0.040
Q114-Q115	NPN	2SC945P		✓	RAN0945-001	0.040
Q120	NPN	2SC945P		✓	RAN0945-001	0.040
Q121	PNP	2SA1264N		✓	RHP1264-001	1.890

DESCRIPTION		REM
TRANSISTORS (A11 ARE CARBON FILM, 1/6 ±5%, UNLESS NOTED OTHERWISE)		
Q122	NPN 2SD882P	RHN0882-001 0.310
Q123	NPN 2SC3181N	RHN3181-001 1.760
RESISTORS (A11 ARE CARBON FILM, 1/6 ±5%, UNLESS NOTED OTHERWISE)		
C124	47K Ω	QAF0650-473 0.006
IC102 PIN 1 TO PIN 2	270K Ω	QAF0850-274
R101	3.3K Ω	QAF0650-332
R102	10K Ω	QAF0650-103
R103	47K Ω	QAF0650-473
R104	68K Ω	QAF0650-683
R106	220K Ω	QAF0650-224
R107	3.3K Ω	QAF0650-332
R108	6.8K Ω	QAF0650-682
R109-R110	1K Ω	QAF0650-102
R111	10K Ω	QAF0650-103
R112	1.0M Ω	QAF0650-105
R113	3.3K Ω	QAF0650-332
R114	22K Ω	QAF0650-223
R115	100K Ω	QAF0650-104
R116	360K Ω	QAF0650-364
R117	220K Ω	QAF0650-224
R118	22K Ω	QAF0650-223
R119	3.3K Ω	QAF0650-332
R121	2.2M Ω	QAF0650-225
R122	22K Ω	QAF0650-223
R123	10K Ω	QAF0650-103
R124	1K Ω	QAF0650-102
R125-R128	15K Ω	QAF0650-153
R129	10K Ω	QAF0650-103
R130	1K Ω	QAF0650-102
R131	18K Ω	QAF0650-183
R132-R133	10K Ω	QAF0650-103
R134	20K Ω	QAF0650-203
R135	18K Ω	QAF0650-183
R136	68K Ω	QAF0650-683
R139	2.2K Ω	QAF0650-222
R140	10K Ω	QAF0650-103
R141	150 Ω	QAF0650-151
R142	1.2K Ω	QAF0650-122
R143	3.9K Ω	QAF0650-392
R144	15K Ω	QAF0650-153
R145	390 Ω	QAF0650-391
R147	15K Ω	QAF0650-153 0.006
R148-R150	10 Ω 1/2 W	QAF0250-100 0.020
R152-R153	0.22 Ω 5 W	QHE5050-228 0.130
R154	100K Ω	QAF0650-104 0.006
R155	10 Ω 1/2 W	QAF0250-100 0.020
R156	56K Ω	QAF0650-563 0.006
R169	33K Ω	QAF0650-333 0.006
R170	2.2K Ω	QAF0650-222 0.006
R171	2.2K Ω 1/4 W	QAF0450-222 0.006
R172	100K Ω	QAF0650-104 0.006
R173	330 Ω	QAF0650-331 0.006

SUB 6

76

NO.	DESCRIPTION		REM
RESISTORS (A11 ARE CARBON FILM, 1/6 ±5%, UNLESS NOTED OTHERWISE)			
R174	10K Ω		QAF0650-103 0.006
R175-R176	220K Ω		QAF0650-224 0.006
R177	470K Ω		QAF0650-474 0.006
R178	10K Ω		QAF0650-103 0.006
R179	47K Ω		QAF0650-473 0.006
ZD102	56 Ω 1/4 W		QAF0450-560 0.006
ZD103	10 Ω 1/4 W		QAF0450-100 0.006
MISCELLANEOUS			
	FLUX	SM-35-10	✓ XFX0516-003 0.030
2SA1264	SIL PAD	3000 +500 LBS	✓ 001X0776001 0.040
2SC3181 USE	SIL PAD	3000 +500 LBS	✓ 001X0776001 0.040
2SD882 USE	SI RUBBER	13X18X0.3T	✓ GSI0001-001 0.040
F101	FUSE	3.15A 250V	✓ KSA2315-001 0.240
JW101-JW127	WIRE BARE	22 Ga TINNED	AI20870-022 0.015
JW901	WIRE BARE	22 Ga TINNED	AI20870-022 0.015
L101	RF COIL	1 uH	✓ SHR6819-001 0.004
R152-R153	SLEEVING	SILICON TUBE	✓ DSL0002-001 0.005
RB302A TO RB302C	FLAT WIRE	8 COND 240 mm	✓ 2468824KCKK 0.230
RB304A TO RB304C	FLAT WIRE	7 COND 240 mm	✓ 2468724KCKK 0.200
RL101	RELAY	MI-SH-212LM	✓ MRL2212-002 1.710
RL102	RELAY	SHINMEI	✓ MRL2212-005 0.790
SVR101	CNTL TRIMR	5KB P= 5X5 mm	✓ MRT0502-002 0.100
uPC1298V USE	SI RUBBER	25X15X0.3T	✓ GSI0003-001 0.050
	AC LINE BUSHING		✓ DBU0002-001 0.060
	CONNECTOR		✓ CCN0027-004 0.020
	FUSE HOLDER		✓ DFH1229-001 0.930
	LINE CORD	SPT-2 198 mm	✓ 47455-052 0.670
	SOLDER BAR		XSD0515-001 0.100
	SOLDER WIRE		XSD9143 0.090
	THIMER OIL	HOLLIS 225	XTN5710 0.015
	THINER FLX	ALPHA 425	XTN5714-002 0.070
	WIRE	26 Ga 100mm	✓ 5820-102BB 0.010

JACK PCB PARTS LIST

REF NO.	DESCRIPTION		REM
CAPACITORS			
C901	COND ELECT	100 uF 16 V 20 %	PRE3952-101 0.050
C904-C907	COND DISC	100 pF 50 V 5 %	PRD8035-101 0.015
CONNECTORS			
CN305A	2 PIN	S2B-XH-A	✓ CCN1500-A42 0.065
RESISTORS (A11 ARE CARBON FILM, 1/6 ±5%, UNLESS NOTED OTHERWISE)			
R901-R902	1.5K Ω	1 W	QHM1050-152 0.040
R903-R904	150K Ω		QAF0650-154 0.006
R905-R907	10K Ω		QAF0650-103 0.006

	DESCRIPTION			REM
JK101	RCA JACK	HTJ-032-24B-20	✓CJR6502-002	0.440
JK102	SPK JACK	JYE TAI CJ-9011 8P(R-B-B-R)	✓CTP0014-001	0.790
SW102-SW103	SW SLIDE	SS020-P022 2P2T	✓MSS8542-002	0.360
CN305A TO CN305B	CON/WIRE	2 COND 200 mm	✓4999A-274	0.510

VR/LED PCB PARTS LIST

REF NO.	DESCRIPTION		REM
MISCELLANEOUS			
CN301	CONNECTOR B2B-XH-A 2 PIN	✓CCN1500-A18	0.060
LD101	LED MULTI COLOR TWO COLOR	✓KEM0001-001	0.170
RB303B TO RB303A	FLAT WORE 3 COND 100 mm	✓2468310KCKK	0.100
VR101	CNTL ROTRY RK16K12B0005 L=15 mm	✓MRR0503-011	0.500
VR102	CNTL ROTRY 50K Ω	✓MRR0503-008	1.750

PHASE PCB PARTS LIST

REF NO.	DESCRIPTION		REM
MISCELLANEOUS			
SW101	SW ROTRY	✓MSR2612-001	1.000

CONNECTOR PCB PARTS LIST

REF NO.	DESCRIPTION		REM
MISCELLANEOUS			
CN305B	CONNECTOR B2B-XH-A 2 PIN	✓CCN1500-A18	0.060
CN901	CONNECTOR 3 PIN POST BASE TOP	✓CCN3941-003	0.070
RB902A TO CN902A	CON/WIRE 2 COND 270 mm	✓4999A-272	0.310
RB307 TO SPK	CON/WIRE 2 COND 300 mm	✓4999A-284	0.210
RB306 TO CN306	CON/WIRE 2 COND 300 mm	✓4999A-275	0.210
RB301 TO CN301A	CON/WIRE 2 COND 350 mm	✓5002ECE9BMM	6.440

176

MARKING PARTS LIST

REF NO.	DESCRIPTION	SUPPLIER PART NO.	REM
1	CARTON	M6148B	3.700
2	OWNER'S MANUAL	P0848	0.260
3	WARRANTY CARD	P0847	0.460
4	TOP POLYFOAM	N1137A	0.460
	PE BAG	V4185	0.200
5	BOTTOM POLYFOAM	N1137B	0.600

DISCREPANCY CHART

MODEL ITEM	SUB 6-100V	SUB 6 -120V	SUB 6 -230V	
X'FORMER	✓TTI1000-001	✓TTI1200-111	✓TTI2300-108	12.900
LINE CORD	✓47455-058	✓47455-052	✓2559-022022	1.430

Sub 10 EXPLODED VIEW

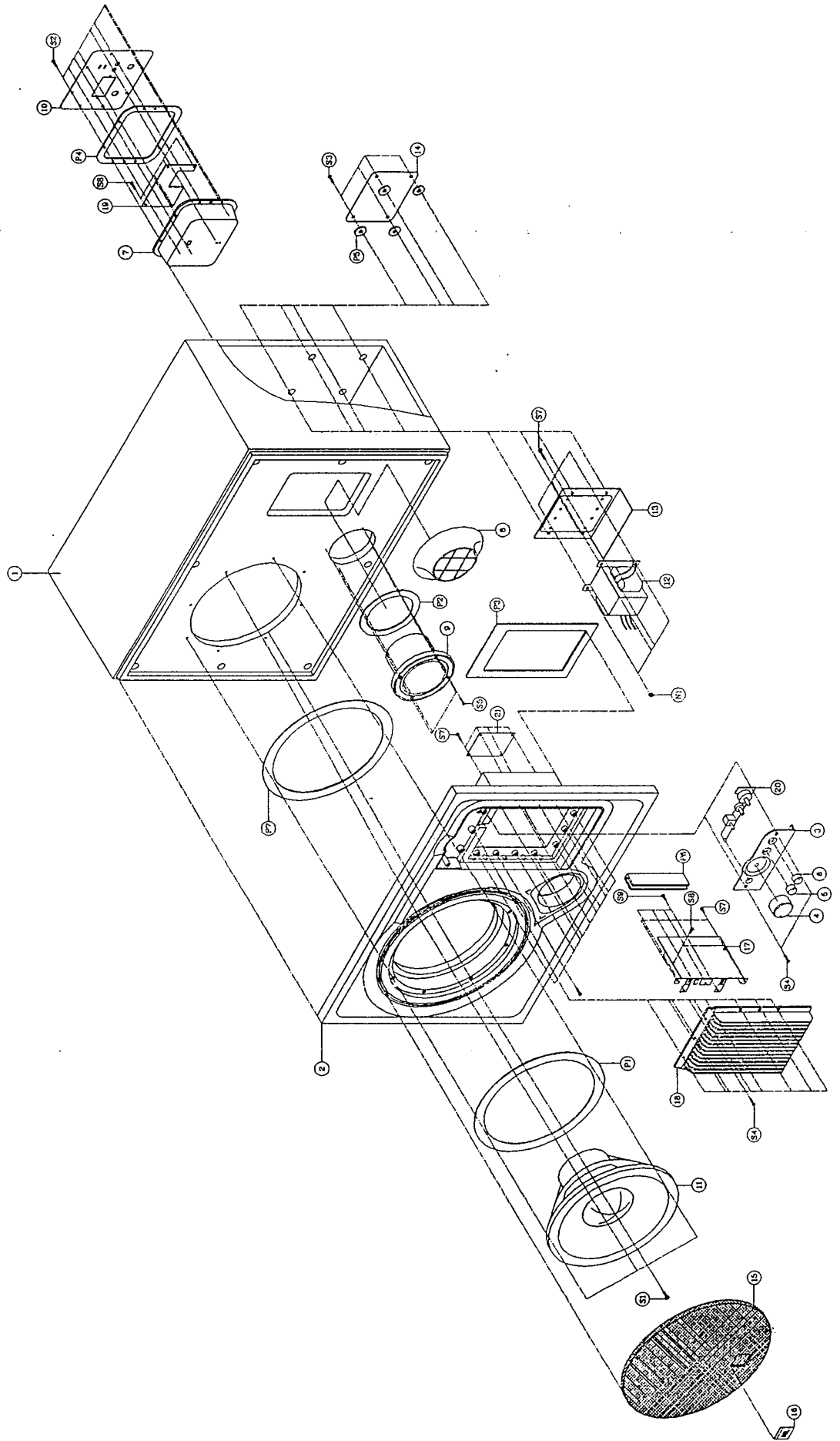

TR6

SUB 10

AMP PCB PARTS LIST

REF NO.	DESCRIPTION				SUPPLIER PART NO.	REM
CAPACITORS						
C101-C102	COND ELECT	4700 uF	63 V	20 %	PVE3958-472	3.140
C103	COND ELECT	100 uF	50 V	20 %	PRE3955-101	0.060
C104	COND ELECT	100 uF	16 V	20 %	PRE3952-101	0.050
C105	COND ELECT	22 uF	50 V	20 %	PRE3955-220	0.050
C106	COND MYLAR	0.033 uF	100 V	5 %	PRM3737-333	0.030
C107	COND ELECT	100 uF	35 V	20 %	PRE3954-101	0.060
C108-C109	COND ELECT	10 uF	35 V	20 %	PRE3954-100	0.030
C110	COND ELECT	0.47 uF	50 V	20 %	PRE3955-478	0.030
C111	COND ELECT	100 uF	10 V	20 %	PRE3951-101	0.030
C112-C113	COND ELECT	100 uF	25 V	20 %	PRE3953-101	0.060
C114	COND DISC	15 pF	50 V	5 %	PRD1335-150	0.015
C115	COND MYLAR	0.068 uF	100 V	5 %	PRM3737-683	0.050
C116-C117	COND MYLAR	0.1 uF	100 V	5 %	PRE3737-104	0.060
C118	COND DISC	100 pF	50 V	5 %	PRD8035-101	0.015
C119	COND ELECT	4.7 uF	50 V	20 %	PRE3955-479	0.030
C120	COND MYLAR	0.033 uF	100 V	5 %	PRM3737-333	0.030
C121	COND MYLAR	0.068 uF	100 V	5 %	PRM3737-683	0.050
C122	COND MYLAR	0.022 uF	100 V	5 %	PRM3737-223	0.030
C123	COND DISC	10 pF	50 V	5 %	PRD8035-100	0.015
C125	COND ELECT	4.7 uF	50 V	20 %	PRE3955-479	0.030
C160	COND ELECT	22 uF	35 V	20 %	PRE3954-220	0.030
C301	COND DISC	56 pF	50 V	5 %	PRD8035-560	0.015
C302	COND DISC	30 pF	50 V	5 %	PRD8035-300	0.015
C303-C304	COND DISC	0.1 uF	50 V	+80-20 %	PRD3965-104	0.030
C305-C308	COND MYLAR	0.1 uF	100 V	5 %	PRM3737-104	0.060
CONNECTORS						
CN306	2 PIN	3951	POST BASE TOP		CCN3951-002	0.040
CN902A	3 PIN	3951	POST BASE TOP		CCN3951-003	0.050
DIODES						
D101-105	RECTIFIER	1N4001			RAD4001-001	0.020
D106-D112	DIODE SW	1N4148			RAD4148-001	0.010
ZD101	DIODE ZENER	23.6-24.7V			RAZ0859-089	0.040
ZD103	DIODE ZENER	14.5-15.1V			RAZ0859-084	0.010
ICS						
IC101	14 PIN	TL074CN			RHI0740-001	1.000
IC102	8 PIN	JRC4558D			RHI4558-001	0.240
IC103	14 PIN	uPC1298V			RHI1298-001	3.570
IC104	3 PIN	78L15			RHI7815-002	0.285
IC105	3 PIN	79L15			RHI7915-002	0.285
TRANSISTORS						
Q101-Q105	NPN	2SC945P			RAN0945-001	0.040
Q106	PNP	2SA733R			RAP0733-001	0.040
Q107	NPN	2SC945P			RAN0945-001	0.040
Q108	PNP	2SA733R			RAP0733-001	0.040
Q109	NPN	2SC945P			RAN0945-001	0.040
Q112	NPN	2SC945P			RAN0945-001	0.040
Q114-Q115	NPN	2SC945P			RAN0945-001	0.040
Q120	NPN	2SC945P			RAN0945-001	0.040
Q121	PNP	2SA1265N			RHP1265-001	1.890

SUB 10

76 115

REF NO.	DESCRIPTION	REF NO.	REM
TRANSISTORS (A11 ARE CARBON FILM, 1/8 ±5%, UNLESS NOTED OTHERWISE)			
Q122	NPN 2SD882P	RHN0882-001	0.310
Q123	NPN 2SC3182N	RHN3182-001	1.760
RESISTORS (A11 ARE CARBON FILM, 1/8 ±5%, UNLESS NOTED OTHERWISE)			
C124	47K Ω	QAF0650-473	0.006
IC102 PIN 1 TO PIN 2	270K Ω	QAF0650-274	
R101	3.3K Ω	QAF0650-332	
R102	10K Ω	QAF0650-103	
R103	47K Ω	QAF0650-473	
R104	68K Ω	QAF0650-683	
R105	820 Ω 2 W	QHM2050-821	
R106	220K Ω	QAF0650-224	
R107	3.3K Ω	QAF0650-332	
R108	6.8K Ω	QAF0650-682	
R109-R110	1K Ω	QAF0650-102	
R111	10K Ω	QAF0650-103	
R112	1.0M Ω	QAF0650-105	
R113	3.3K Ω	QAF0650-332	
R114	22K Ω	QAF0650-223	
R115	100K Ω	QAF0650-104	
R116	360K Ω	QAF0650-364	
R117	220K Ω	QAF0650-224	
R118	22K Ω	QAF0650-223	
R119	3.3K Ω	QAF0650-332	
R121	2.2M Ω	QAF0650-225	
R122	22K Ω	QAF0650-223	
R123	10K Ω	QAF0650-103	
R124	1K Ω	QAF0650-102	
R125-R128	15K Ω	QAF0650-153	
R129	10K Ω	QAF0650-103	
R130	1K Ω	QAF0650-102	
R131	18K Ω	QAF0650-183	
R132-R133	10K Ω	QAF0650-103	
R134-R135	18K Ω	QAF0650-183	
R136	180K Ω	QAF0650-184	
R139	2.2K Ω	QAF0650-222	
R140	10K Ω	QAF0650-103	
R141	150 Ω	QAF0650-151	
R142	1.2K Ω	QAF0650-122	
R143	3.9K Ω	QAF0650-392	
R144	15K Ω	QAF0650-153	
R145	390 Ω	QAF0650-391	
R147	15K Ω	QAF0650-153	0.006
R148-R150	10 Ω 1/2 W	QAF0250-100	0.015
R151	820 Ω 2 W	QHM2050-821	0.090
R152-R153	0.22 Ω 5 W	QHE5050-228	0.130
R154	100K Ω	QAF0650-104	0.006
R155	10 Ω 1/2 W	QAF0250-100	0.015
R156	56K Ω	QAF0650-563	0.006
R157	10K Ω	QAF0650-103	0.006
R169	33K Ω	QAF0650-333	0.006
R170	2.2K Ω	QAF0650-222	0.006
R171	2.2K Ω 1/4 W	QAF0450-222	0.006
R172	100K Ω	QAF0650-104	0.006

SUB 10

17/16

REF NO.	DESCRIPTION		REM
RESISTORS (A11 ARE CARBON FILM, 1/6 ±5%, UNLESS NOTED OTHERWISE)			
R173		330 Ω	QAF0850-331 0.006
R174		10K Ω	QAF0850-103 0.006
R175-R176		220K Ω	QAF0850-224 0.006
R177		470K Ω	QAF0850-474 0.006
R178		10K Ω	QAF0850-103 0.006
R179		47K Ω	QAF0850-473 0.006
ZD102		560 Ω 1 W	QHM1050-561 0.050
MISCELLANEOUS			
2SA1284	FLUX	SM-35-10	✓ XFX0516-003 0.030
2SC3181 USE	SIL PAD	3000 +-500 LBS	✓ 001X0778001 0.040
2SD882 USE	SIL PAD	3000 +-500 LBS	✓ 001X0778001 0.040
F101	SI RUBBER	13X18X0.3T	✓ GSI0001-001 0.040
JW101-JW127	FUSE	4A 250V	✓ KSA2400-001 0.150
JW901	WIRE BARE	22 Ga TINNED	AI20870-022 0.015
L101	WIRE BARE	22 Ga TINNED	AI20870-022 0.015
R152-R153	RF COIL	1 uH	✓ SHR8619-001 0.040
RB302A TO RB302	SLEEVING	SILICON TUBE	✓ DSL0002-001 0.005
RB304A TO RB304	FLAT WIRE	8 COND 240 mm	✓ 2468824KCCK 0.230
RL101	FLAT WIRE	7 COND 240 mm	✓ 2468724KCCK 0.200
RL102	RELAY	MI-SH-212LM	✓ MRL2212-002 1.710
SVR101	RELAY	SHINMEI	✓ MRL2212-005 0.790
uPC1298V USE	CNTL TRIMR	5KB P= 5X5 mm	✓ MRT0502-002 0.100
	SI RUBBER	25X15X0.3T	✓ GSI0003-001 0.050
	AC LINE BUSHING		✓ DBU0002-001 0.060
	CONNECTOR		✓ CCN0027-004 0.020
	FUSE HOLDER		✓ DFH1229-001 0.930
	LINE CORD	SPT-2 198 mm	47455-052 0.670
	SOLDER BAR		XSD0515-001 0.100
	SOLDER WIRE		XSD9143 0.090
	THIMER OIL	HOLLIS 225	XTN5710 0.015
	THINER FLX	ALPHA 425	XTN5714-002 0.070
	WIRE	26 Ga 100mm	✓ 5820-102BB 0.010

JACK PCB PARTS LIST

REF NO.	DESCRIPTION		REM
CAPACITORS			
C901	COND ELECT	100 uF 16 V 20 %	PRE3952-101 0.050
C904-C907	COND DISC	100 pF 50 V 5 %	PRD8035-101 0.015
CONNECTORS			
CN305A	2 PIN	S2B-XH-A	✓ CCN1500-A42 0.065
RESISTORS (A11 ARE CARBON FILM, 1/6 ±5%, UNLESS NOTED OTHERWISE)			
R901-R902		1.5K Ω 1 W	QHM1050-152 0.040
R903-R904		150K Ω	QAF0850-154 0.006
R905-R907		10K Ω	QAF0850-103 0.006
MISCELLANEOUS			
JK101	RCA JACK	HTJ-032-24B-20	✓ CJR6502-002 0.440
JK102	SPK JACK	JYE TAI CJ-9011 8P(R-B-B-R)	✓ CTP0014-001 0.790

SUB 10

176 1/1

REF NO.	DESCRIPTION		REM
MISCELLANEOUS			
SW102-SW103	SW SLIDE	SS020-P022 2P2T	MSS8542-002 ✓ MSS8542-002 0.360
CN305A TO CN305	CON/WIRE	2 COND 280 mm	✓ 4999A-288 0.600

VR/LED PCB PARTS LIST

REF NO.	DESCRIPTION		REM
MISCELLANEOUS			
CN301A	CONNECTOR	B2B-XH-A 2 PIN	✓ CCN1500-A18 0.060
LD101A	LED	MULTI COLOR	TWO COLOR ✓ KEM0001-001 0.170
RB303C TO RB303	FLAT WIRE	3 COND 100 mm	✓ 2468310KCKK 0.100
VR101A	CNTL ROTRY	RK16K12B0005	L=15 mm ✓ MRR0503-011 0.500
VR102A	CNTL ROTRY	50K Ω	✓ MRR0503-008 1.750

PHASE PCB PARTS LIST

REF NO.	DESCRIPTION		REM
MISCELLANEOUS			
SW101	SW ROTRY		✓ MSR2612-001 1.000

CONNECTOR PCB PARTS LIST

REF NO.	DESCRIPTION		REM
MISCELLANEOUS			
CN305B	CONNECTOR	B2B-XH-A 2 PIN	✓ CCN1500-A18 0.060
CN901	CONNECTOR	3 PIN	POST BASE TOP ✓ CCN3941-003 0.070
RB902A TO CN902	CON/WIRE	2 COND 270 mm	✓ 4999A-272 0.310
RB307 TO SPK	CON/WIRE	2 COND 340 mm	✓ 4999A-273 0.210
RB308 TO CN308	CON/WIRE	2 COND 300 mm	✓ 4999A-275 0.210
RB301 TO CN301A	CON/WIRE	2 COND 350 mm	✓ 5002ECE9BMM 0.440

MECHANICAL PARTS LIST

REF NO.	DESCRIPTION	SUPPLIER PART NO.	REM
1	WOOD BOX	EVM0005-001	36.400
2	FRONT CAB BLACK	✓ J1334B	8.600
3	CNTL PANEL REFLEX BLUE C	✓ J3405	0.570
4	VOL. KNOB	✓ J3403B	0.200
5	FREQ. KNOB	✓ J3402B	0.200
6	PHASE KNOB	✓ J3404B	0.200
7	REAR COVER	✓ J3400	0.500
8	PORT EDGE	✓ J2095B	0.300
9	PORT TUBE	✓ J2095A	0.360
10	JACK PLATE	✓ K6249	1.150
11	SPK DRIVER	✓ C0012B	28.600
12	X'FORMER	✓ E4223	20.700
13	X'FORMER BRACKET	✓ K6250	0.900
14	X'FORMER PLATE	✓ K6251	0.710
15	GRILLE	✓ K6252	2.850
16	LOGO PLATE	✓ J3296/K6228A	0.460
17	AMP PCB ASS'Y	✓ E4227	36.400
18	HEAT SINK	✓ K6253	11.800
19	JACK PCB ASS'Y	✓ E4228	2.850
20	VR/LED PCB ASS'Y	✓ E4224	3.570
21	CONNECTOR PCB ASS'Y	✓ E4226	1.430
22	PCB BRACKET	✓ GSE0073-002	0.150
23	FUSE HOLDER	✓ E4214B	1.000
24	LINE CORD	✓ E4215	1.430
25	SW PCB ASS'Y	✓ E4225	1.430
N1	NUT FOR PLT+X'FORMER BKT	✓ HNI1482	0.030
P1	DRIVER SPONGE	✓ E3297K	0.300
P2	PORT SPONGE	✓ J3297H	0.080
P3	FRONT SPONGE	✓ J3297J	0.570
P4	COVER SPONGE	✓ J3297E	0.200
P5	X'FORMER SPONGE	✓ J3297A	0.020
P6	AMP SPONGE	✓ J3297B	0.070
P7	BAFFLE SPONGE	✓ J3297L	0.200
S1	SCREW FOR SPK 8ψ xM4xL50	✓ F5010	0.030
S2	SCREW FOR JACK PLATE 9ψ xM4xL20	✓ F2021	0.030
S3	SCREW FOR X'FORMER PLT 9ψ xM5xL25	✓ F2509	0.030
S4	SCREW FOR CNTL PANEL / HSINK 6.5ψ xM3xL16	✓ F1618	0.010
S5	SCREW FOR PORT TUBE 7ψ xM4xL12	✓ F1226	0.010
S6	SCREW FOR BAFFLE 8ψ xM4xL25	✓ F2507	0.020
S7	SCREW FOR PLT+X'FORMER BKT / PCB BKT TO HSINK	✓ F1813	0.010
S8	SCREW FOR JACK PCB / AMP PCB 5.3ψ xM3xL10	✓ F1014	0.010
S9	SCREW FOR PCB TO PCB BKT / IC TO HSINK 3ψ xL8	✓ H120301-308	0.010

SUB 10

PACKING PARTS LIST

REF NO.	DESCRIPTION	SUPPLIER PART NO.	REM
1	POLYFOAM (TOP)	✓ N1138A	0.720
2	POLYFOAM (BOTTOM)	✓ N1138B	0.720
3	PE BAG	Do NOT stock ✓ V4185A	0.300
4	CARTON	✓ M6147B	6.000
5	OWNER'S MANUAL	✓ P0848	0.260
6	WARRANTY CARD	✓ P0847	0.460

DISCREPANCY CHART

MODEL ITEM	SUB 10-100V	SUB 10-120V	SUB 10-230V	
X'FORMER	✓ TTK1000-001	✓ TTK1200-003	✓ TTK2300-001	20.700
LINE CORD	47455-058 ✓	47455-052 ✓	2559-022022 ✓	1.430