



TSS-SUB4000

SERVICE MANUAL



Infinity Systems Incorporated
250 Crossways Park Dr.
Woodbury, New York 11797

Rev1 10/2005

CONTENTS

BASIC SPECIFICATIONS	1
DETAILED SPECIFICATIONS	2
CONTROLS.	4
CONNECTIONS	5
OPERATION.....	6
EXPLODED VIEWS-MECHANICAL PARTS LIST.....	7
TEST SET-UP & PROCEDURE.....	9
BLOCK DIAGRAM.	10
TROUBLESHOOTING FLOW CHART.....	11
SERVICE NOTE - POWER TRANSFORMER.....	12
ELECTRICAL PARTS LIST	13
PCB DRAWINGS.	17
IC – TRANSISTOR PINOUTS	20
SCHEMATIC DIAGRAMS (120v).	21
PACKAGING.	31

SPECIFICATIONS

Frequency Response	28Hz – 150Hz (–3dB) 24Hz – 180Hz (–6dB)
Maximum Amplifier Output	400 watts RMS (20Hz – 150Hz with no more than 0.1% THD)
Crossover Frequency	150Hz, 12dB/octave
Driver	12" (305mm) MMD®
Dimensions (H x W x D)	17-1/2" x 17-1/4" x 11-1/8" (445mm x 438mm x 283mm)
Weight	48 lb (21.8kg)

Infinity continually strives to update and improve existing products, as well as create new ones. The specifications and construction details in this and related Infinity publications are therefore subject to change without notice.

TSS-4000 subwoofer 300W Powered Sub/ Plate Amp					
LINE VOLTAGE	Yes/No	Hi/Lo Line	Nom.	Unit	Notes
US 120vac/60Hz	Yes	108-132	120	Vrms	Normal Operation
EU 230vac/50-60Hz	No	207-264	230	Vrms	Normal operation, MOMS required
Asia 100vac/50Hz	No	90-110	100	Vrms	Normal Operation
Parameter	Specification	Unit	QA Test Limits	Conditions	Notes
Amp Section					
Type (Class AB, D, other)	D	---			
Load Impedance (speaker)	4	Ohms		Nominal	Z-curve required
Rated Output Power	300	Watts		Regulated 120 V line	5% tolerance applies
THD@ Rated Power	1	%		22k filter, 50Hz	300W +/- 5%
THD @ 1 Watt	0.5	%		22k filter, 50Hz	
DC Offset	undefined	mV-DC	< 20	@ Speaker Outputs	
Damping factor	20	N/A	> 15		measured at 50 Hz
Input Sensitivity					
Line/Hi Level Input Phase	N/A				
Line Input	370 mV	mVrms		300 W @ 50Hz	1 input driven
Speaker/Hi Level Input	N/A				
Signal to Noise					
SNR-A-Weighted	100	dBA		relative to rated power	A-Weighting filter
SNR-unweighted	70	dBr		relative to rated power	22k filter
SNR rel. 1W-unweighted	60	dBr		relative to 1W Output	22k filter
Residual Noise Floor	2	mVrms		Volume @max, using RMS reading DMM/VOM (or A/P)	
Residual Noise Floor	1	mVrms(max)		Volume @max, w/ A/P Swept Bandpass Measurement (Line freq.+ harmonics)	
Input Impedance					
Line Input	10 k	ohms		Nominal	
Speaker/Hi Level Input	N/A				
Active Filters					
Low Pass (fixed or variable)					
	FIXXED	--			
Frequency	130	Hz			
Slope	24	dB/Octave			
Q	Butterworth	--			
Subsonic filter (HPF)					
	fixed	--			
Frequency	35	Hz			
Slope	12	dB/Octave			
Q	1.2	--			
Line Out Filter (HPF)					
	NONE	--			
Frequency		Hz			
Slope		dB/Octave			
Q		--			
Friend Circuit					
	FIXXED	--			
Frequency	66 Hz	Hz		notch filter	
Slope	6	dB/Octave			
Q	1.2	--			
Video Boost					
	NONE	--			
Boost		dB			
Range		Hz			
Special filter					
	RABOS	--			
Switches					
Main Power ON/OFF	YES	--			
Type	rocker	--		Located on amp plate	TV-5
Rabos ON/OFF	YES	--			
Type	mini toggle	--		Located on amp plate	
Polarity Switch	YES	--		"Off": 0°; "On": 180°	
Type	mini toggle	--		Located on amp plate	
Limiters (yes/no)					
	YES				compressor and limiter

Parameter	Specification	Unit	QA Test Limits	Conditions	Notes
THD at Max. Output Power	less than 10	%		Maximum Output Power	Maximum THD as a result of limiting.
Output Volume Control					
Volume Control Pot	YES	--		mounted on amp panel	
Detent (center/#)	NO	--			
Taper (lin/log)	log A taper	--			
@ minimum setting	no output				
Input/Output Phase					
Line Input vs. Hi Input	N/A	°			
Lo/Hi Input vs. Lo/Hi Output	N/A	°			
Input/Output					
Line In (L,C,R,AC3,Mono)	Stereo	--		RCA phono jack, gold plated	
LFE In	YES	--		Shared with "R" Line In jack	
Signal Sensing (ATO)					
Auto-Turn-On (yes/no)	YES	--			
ATO Input Test Frequency	100	Hz			
ATO Input Threshold	2	mV	typ.		LPF "On", BOS "Off"
ATO Low Pass cutoff	400	Hz	450	ATO-LPF for noise immunity	LPF "On", BOS "Off"
ATO Turn-on time	1	ms	10	Amp connected and AC on, then input signal applied (1 W output)	
Auto Mute / Turn-OFF Time	10	minutes	5 < t < 15	Time before muting, after signal is removed	
Power on Features					
Power on Delay time	greater than 2	sec.		AC Power Applied	
Power on LED	YES	--		Bi-color LED located on front of cabinet	
Normal On/Off	green / red	color		ATO mode only	
ATO	--	color		"Active": green; "Standby": red	
Transients/Pops					
ATO Transient	5	mV-peak		@ Speaker Output	
Turn-on Transient	30	mV-peak		@ Speaker Output	AC Line cycled from OFF to ON
Turn-off Transient	30	mV-peak		@ Speaker Output	AC Line cycled from ON to OFF
Efficiency					
Stand-by Input Power	10	Watts	typ.	@ nom. line voltage	
AC Power Cons.@1W	12	Watts	typ.	@ nom. line voltage	
Power Cons.@rated power	473	Watts	typ.	@ nom. line voltage	Input power measured is REAL Watts, not VA
Efficiency	63	%	typ.	@ nom. line voltage	
Protection					
Short Circuit Protection	YES	--		Direct short at output	
Thermal Protection	YES	--		threshold ~ 65 deg. C at panel	
DC Offset Protection	YES	--		DC present at Speaker Out leads	Relay for driver/fire protection
Line Fuse Rating (120 V)	3.15	Amps		Type ADL or MDL	Fuse holder on inside surface of amp panel
AC Power & Transformer					
Power cord length	9	feet		Double insulated cord, AWG#18	

CONTROLS AND CONNECTIONS

Rear Panel

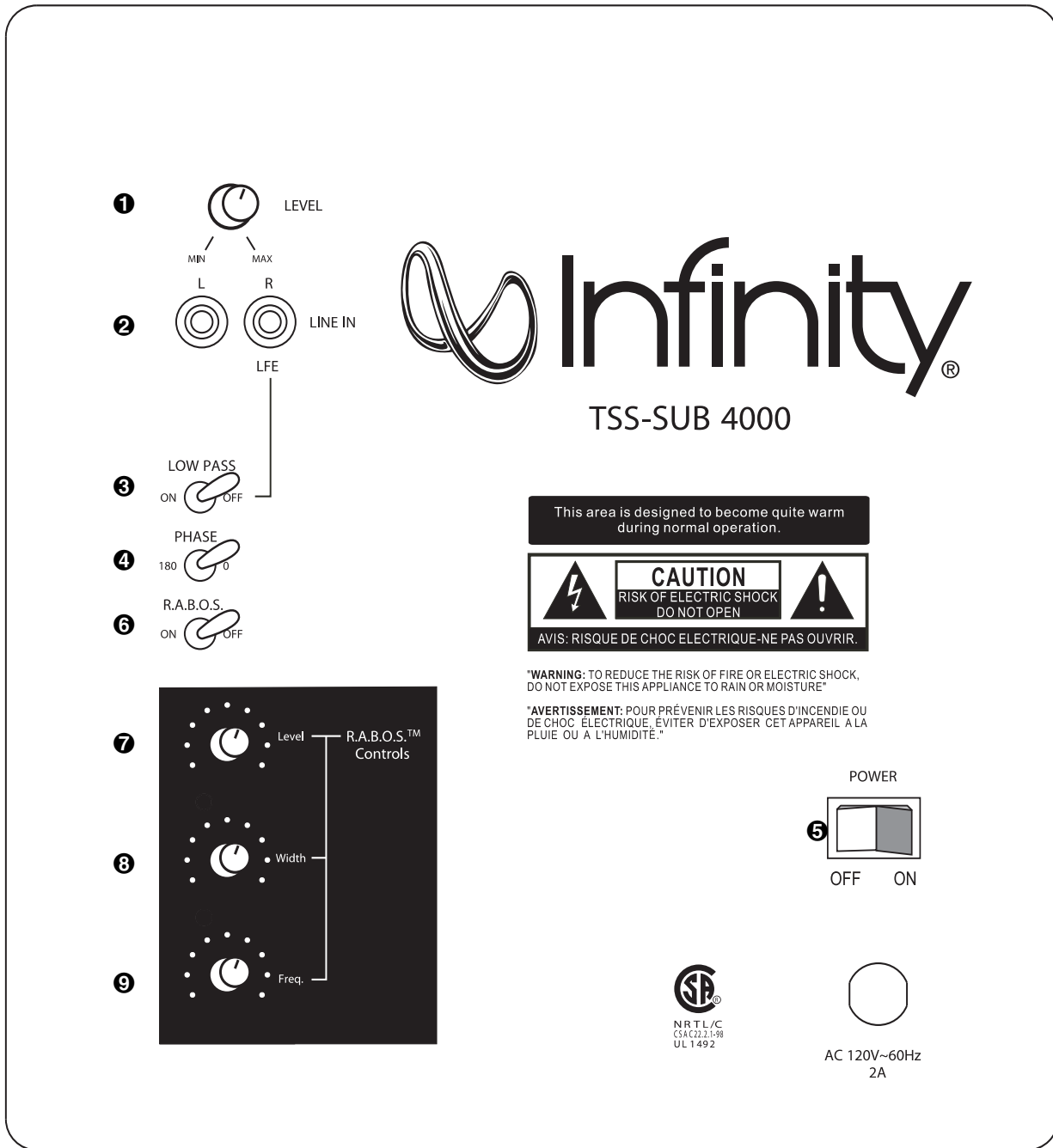

- 1** Subwoofer Level (Volume) Control
- 2** Line-Level Inputs
- 3** Normal/LFE Low-Pass Selector
- 4** Phase Switch
- 5** Power Switch

Room Adaptive Bass Optimization System Controls (see page 5)

- 6** R.A.B.O.S. Selector
- 7** R.A.B.O.S. Level Adjustment
- 8** R.A.B.O.S. Bandwidth Adjustment
- 9** R.A.B.O.S. Center-Frequency Adjustment

CONNECTIONS

If you have a Dolby® Digital or DTS® receiver/processor with a low-frequency-effects (LFE) output:

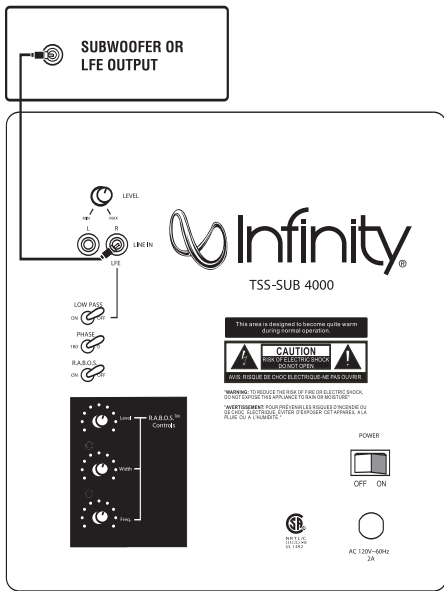

• Set Low-Pass Switch to Off.

NOTE: In this case, you do not need to use a Y connector. Simply connect the LFE output on your receiver/processor to either the left or right input on the subwoofer.

If your receiver/processor has subwoofer outputs for the left and right channels:

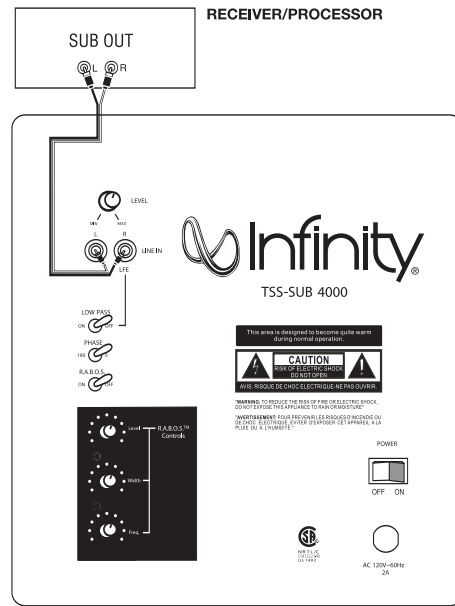

• Set Low-Pass Switch to On.

NOTE: Some receivers have a single subwoofer output (do not confuse this with a single LFE output as described to the left). In that case, it is recommended that you use a Y connector (not included) to maximize performance.

OPERATION

Power On

Plug your subwoofer's AC cord into a wall outlet. Do not use the outlets on the back of the receiver.

Initially set the Subwoofer Level (Volume) Control **1** to the "min" position.

Turn on your sub by pressing the Power Switch **5** on the rear panel.

Auto On/Standby

With the Power Switch **5** in the ON position, the Power Indicator LED on the front of the subwoofer will remain backlit in red or green to indicate the On/Standby mode of the subwoofer.

RED = STANDBY (No signal detected, Amp Off)

GREEN = ON (Signal detected, Amp On)

The subwoofer will automatically enter the Standby mode after approximately 10 minutes when no signal is detected from your system. The subwoofer will then power ON instantly when a signal is detected. During periods of normal use, the Power Switch **5** can be left on. You may turn off the Power Switch **5** for extended periods of nonoperation, e.g., when you are away on vacation.

Adjust Gain

Turn on your entire audio system and start a CD or movie soundtrack at a moderate level. Turn up the Subwoofer Level (Volume) Control **1** about halfway. If no sound emanates from the subwoofer, check the AC-line cord and input cables. Are the connectors on the cables making proper contact? Is the AC plug connected to a "live" receptacle? Has the Power Switch **5** been pressed to the "On" position? Once you have confirmed that the subwoofer is active, proceed by playing a CD, record or cassette. Use a selection that has ample bass information.

Set the overall volume control of the preamplifier or stereo to a comfortable level. Adjust the Subwoofer Level (Volume) Control **1** until you obtain a pleasing blend of bass. Bass response should not overpower the room but rather should be adjusted so there is a harmonious blend across the entire musical range. Many users have a tendency to set the subwoofer volume too loud, adhering to the belief that a subwoofer is there to produce lots of bass. This is not entirely true. A subwoofer is there to enhance bass, extending the response of the entire system so the bass can be felt as well as heard. However, overall balance must be maintained or the music will not sound natural. An experienced listener will set the volume of the subwoofer so its impact on bass response is always there but never obtrusive.

Low-Pass Selector

If you have a Dolby Digital or DTS processor/receiver, the Crossover Frequency is set by the processor/receiver. Consult your owner's manual to learn how to view or change this setting. In this case, the Low-Pass Selector **3** should be set to "Off". We strongly recommend this setup method.

When this switch **3** is in the "On" position, the subwoofer will reproduce frequencies below 150Hz.

Phase Control

The Phase Switch **4** determines whether the subwoofer speaker's piston-like action moves in and out with the main speakers, 0°, or opposite the main speakers, 180°. Proper phase adjustment depends on several variables such as room size, subwoofer placement and listener position. Adjust the phase switch to maximize bass output at the listening position.

TSS-SUB4000 EXPLODED VIEW

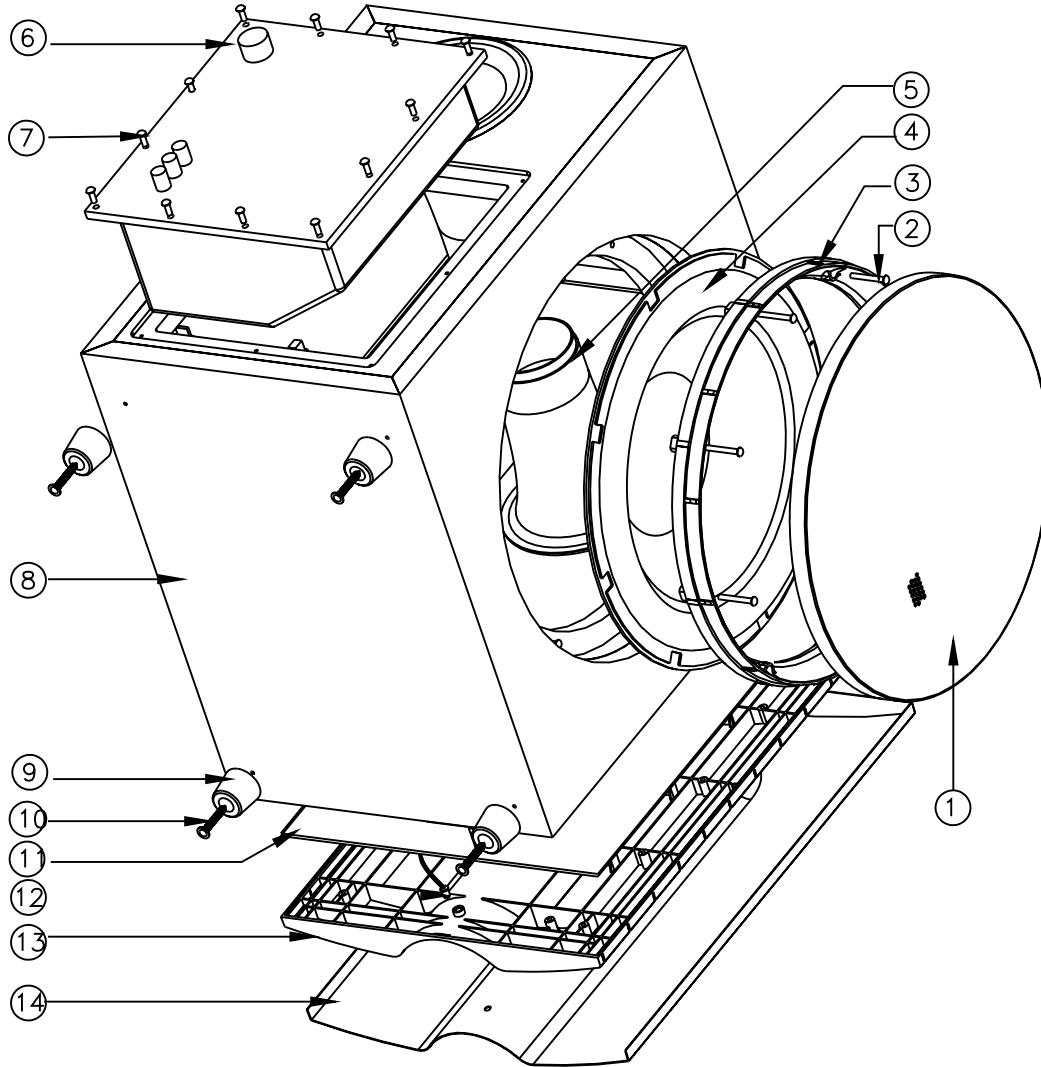

Ref #	Description	Part Number	Qty
1	Grille	329-120-05097-0VA	1
2	Woofer/Trim Ring Screw	351-AM04030A893	8
3	Trim Ring	213-120-05033-0BA	1
4	Woofer 12" (305mm) MMD	30PR14BW-DW01	1
5	Port Tube	249-HIPS-05021-0VA	1
6	TSS-SUB4000 Amplifier	Not for Sale	1
7	Amplifier Screw	352-FM04020D605	12
8	TSS-SUB4000 Cabinet	Not for Sale	1
9	Rubber Foot	320-RUB-05030-0BA	4
10	Foot Screw	352-CM04025D604	4
11	Gasket	333-EVA-05091-0WA	1
12	LED	166-A055A8GX	1
13	Plastic Plate	Not Serviceable	1
14	Aluminum Plate	Not Serviceable	1
Not Shown	Power Transformer	150-R1107008	1

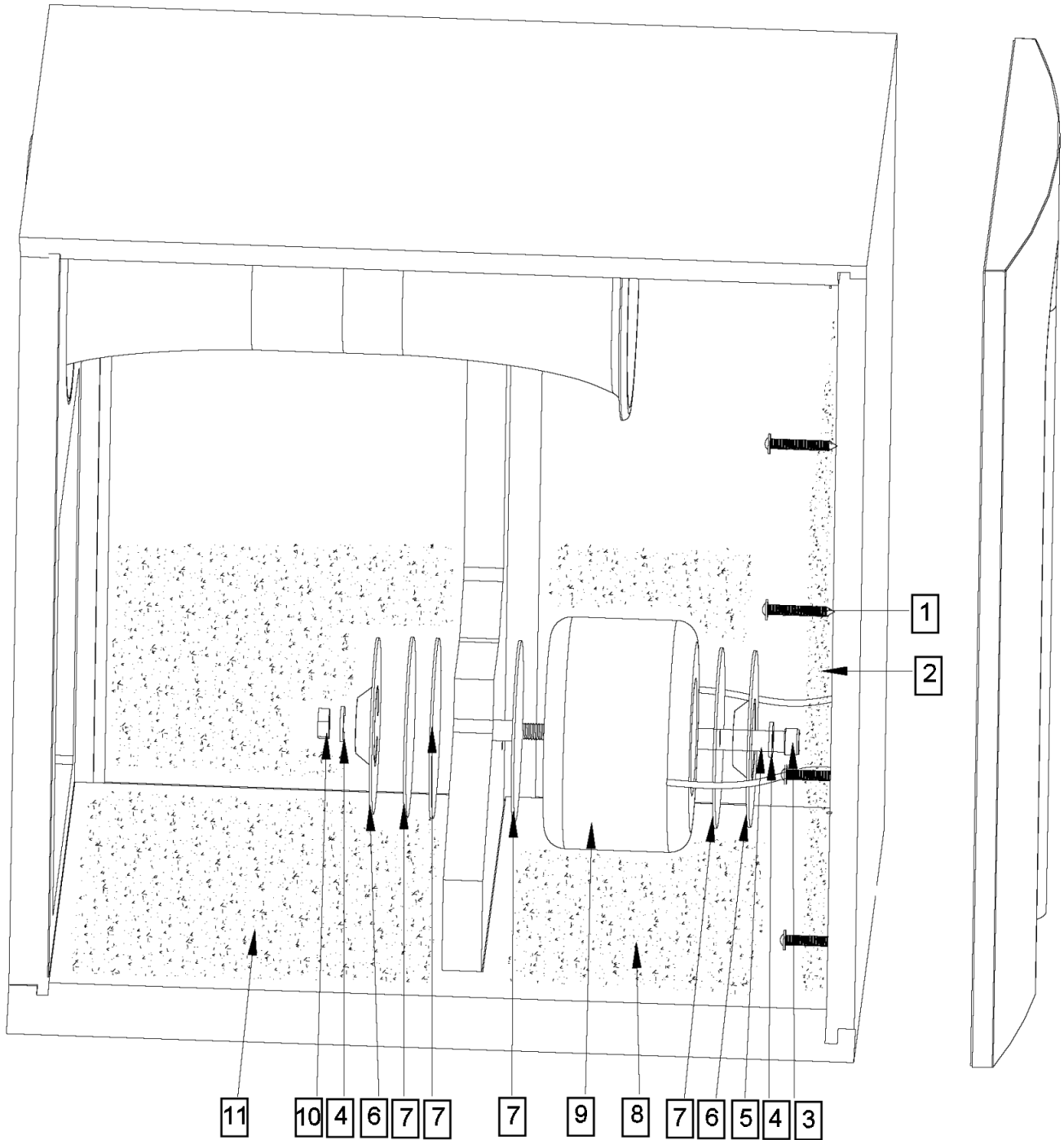

Ref #	Description	Part Number	Qty
1	Screw	352-CM03530D926	11
2	Damping		1
3	Main Mounting Bolt		1
4	Tube Gasket		2
5	Rubber	398-RUB-05093	1
6	Gasket		2
7	Rubber Gasket	336-RUB-05013	1
8	Damping		1
9	Power Transformer	150-R1107008	1
10	Nut		1
11	Damping		1

TSS-SUB4000 Test Set Up and Procedure

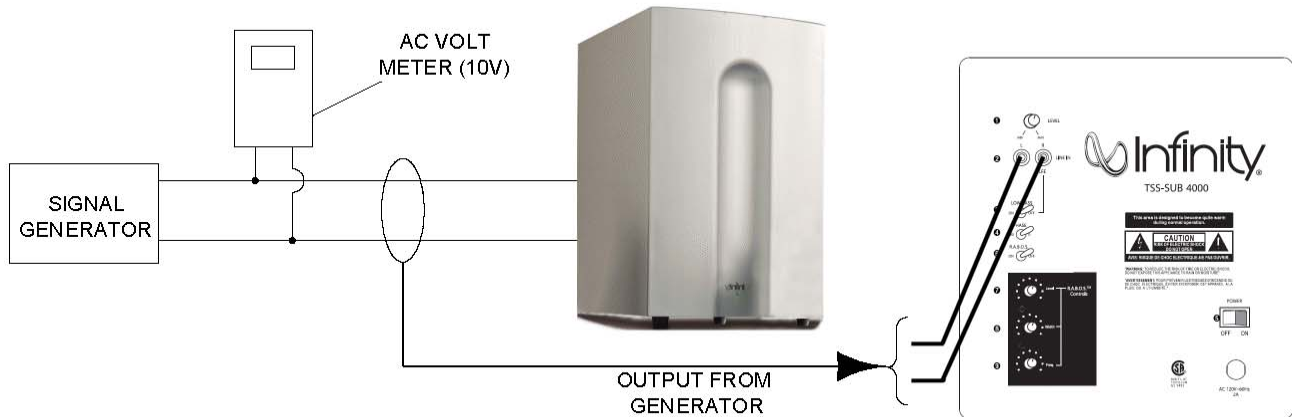

SYSTEM AURAL SWEEP TEST

Equipment needed:

- Function/signal generator/sweep generator
- Multimeter
- RCA cables

General Unit Function (UUT = Unit Under Test)

Switches/knobs on the amplifier faceplate:

Phase switch – either position

Low Pass switch – Off

RABOS switch – Off

1. From the signal generator, Connect both right and left line level inputs (RCA jacks) – to signal generator and UUT. Use Y-cable if necessary from mono source.
2. On the amplifier, turn the LEVEL control full Counterclockwise (Min).
3. Turn on generator, adjust to **125mV, 50 Hz**.
4. Plug in UUT; turn the power switch ON. Turn LEVEL control full Clockwise (Max).
5. LED (on front panel) should now be Green; immediate bass response should be heard and felt from rear port tube opening.

Sweep Function

1. Follow steps 1-5 above, using a sweep generator as a signal source.
2. Sweep generator from 20Hz to 1kHz. Listen to the cabinet and drivers for any rattles, clicks, buzzes or any other noises. If any unusual noises are heard, remove woofer and test.

Driver Function (Woofer)

1. Remove woofer from cabinet (follow steps on exploded view page); detach + and - wire clips.
2. Check DC resistance of woofer; it should be **3.5 ohms±10%**.
3. Connect a pair of speaker cables to driver terminals. Cables should be connected to an integrated amplifier fed by a signal generator. Turn on generator and adjust so that speaker level output is **5.0V**.
4. Sweep generator from 20Hz to 1kHz. Listen to driver for any rubbing, buzzing, or other unusual noises.

TSS-SUB4000PLT AMPLIFIER BLOCK DIAGRAM

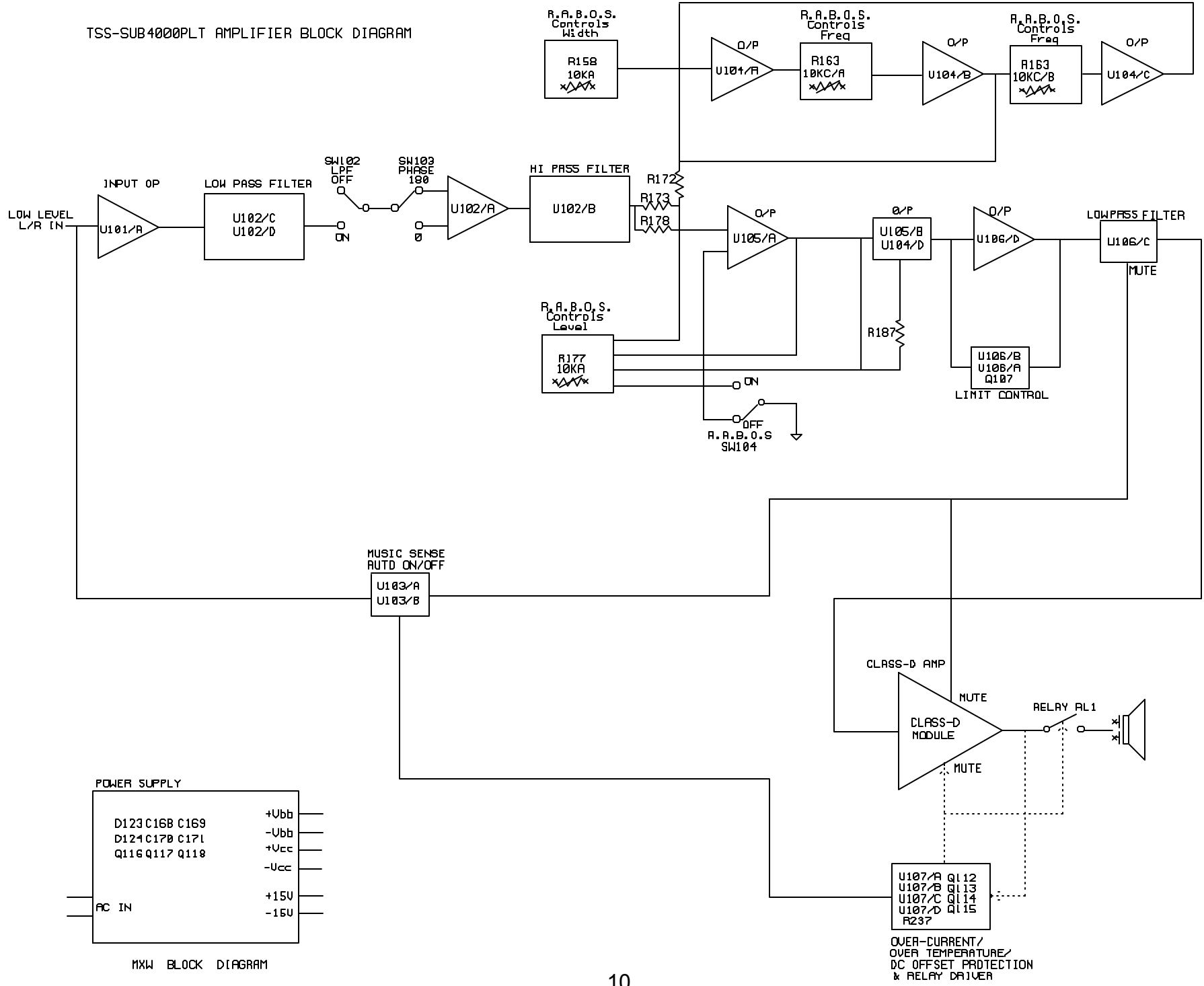

OVER-CURRENT/
OVER-TEMPERATURE/
DC OFFSET PROTECTION
& RELAY DRIVER

TSS-Sub4000 Testing Flow Chart

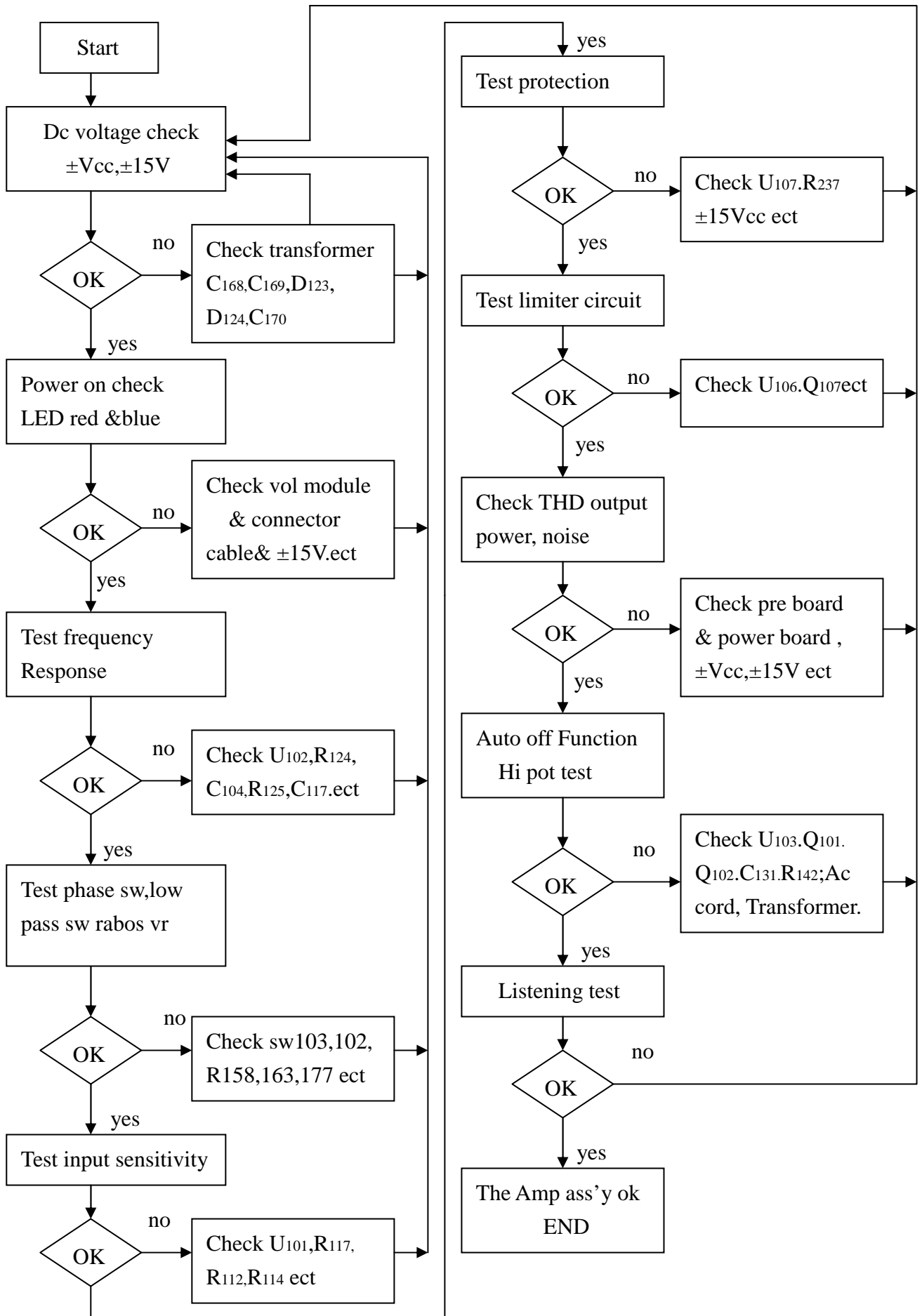

NOTICE

The main power transformer (toroid) part# 150-r1107008 in the TSS-SUB4000 is not mounted in the amplifier inside the amp cover, but mounted in the cabinet in a separate location.

Replacement:

To replace the power transformer, it is necessary to remove the woofer from the cabinet. The mounting bolt and transformer itself is mounted on an internal brace; both are accessible through the woofer opening. Instructions for woofer removal can be found on the exploded view, page 7.

Troubleshooting:

To keep the circuit “live” while exposing the amplifier components, the amplifier cannot completely be removed and powered up outside the cabinet due to the power connections to the externally mounted transformer. Instead, an alternate method is to leave the amp cover in place and remove the four Phillips screws holding the amp ass’y to the amp cover. Then the amplifier can be partially removed for access, while maintaining the power connections. Unplugging the LED connection (red/black wires) at the PCB plug will allow the amp to be removed even further.

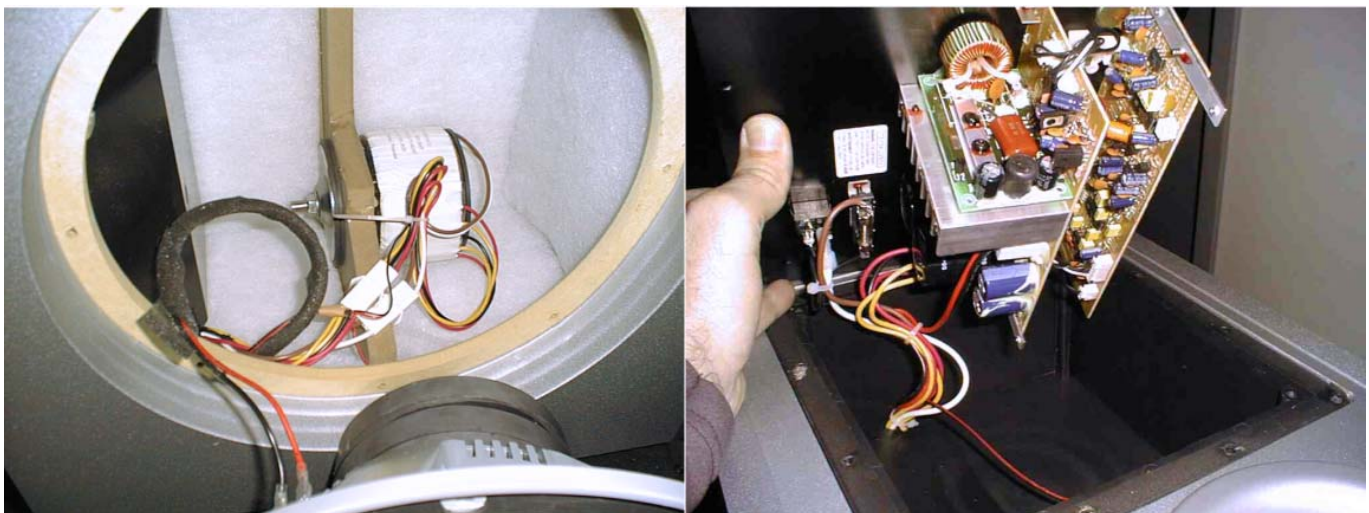

TSS-SUB4000 120V Electrical Parts List			
Part Number	Description	Qty	Reference Designator
MAIN PCB			
<i>Resistors</i>			
110-12621j15	Resistor 620Ω1/2W ± 5% 15mm	1	R238
110-16102j26	Resistor 1K 1/6W ± 5% CF 26mm	3	R210,R239,R264
110-16103j26	Resistor 10K 1/6W ± 5% CF 26mm	9	R227,229,230,231,232,233,260,261,263
110-16153j26	Resistor 15K 1/6W ± 5% CF 26mm	2	R247,R249
110-16182j26	Resistor 1.8K 1/6W ± 5% CF 26mm	1	R248
110-16222j26	Resistor 2.2K 1/6W ± 5% CF 26mm	2	R242,R245
110-16223j26	Resistor 22K 1/6W ± 5% CF 26mm	3	R218,R220,R223
110-16274j26	Resistor 270K 1/6W ± 5% CF 26mm	1	R240
110-16333j26	Resistor 33K 1/6W ± 5% CF 26mm	1	R211
110-16391j26	Resistor 390Ω1/6W CF 26mm	2	R243,R246
110-16432j26	Resistor 4.3K 1/6W ± 5% CF 26mm	1	R254
110-16472j26	Resistor 4.7K 1/6W ± 5% CF 26mm	4	R217,219,222,213
110-16473j26	Resistor 47K 1/6W ± 5% CF 26mm	1	R221
110-16683j26	Resistor 68K 1/6W ± 5% CF 26mm	1	R212
122-14101j26	fusible Resistor 1/4W 100ohm 5%	2	R241,R244
116-141r00j26x	metal film Resistor 1.00Ω1/4W ± 5% MO 26mm	2	R256,R255
116-161001f26	metal film Resistor 1K 1/6W ± 1% MF 26mm	2	R252,R253
116-161002f26	metal film Resistor 10K 1/6W ± 1% MF 26mm	2	R234,R235
116-161022f26	metal film Resistor 10.2K 1/6W MF 26mm	1	R251
116-161301f26	metal film Resistor 1.30K 1/6W MF 26mm	3	R226,R228,R236
116-161822f26	metal film Resistor 18.2K 1/6W ± 1% MF 26mm	1	R214
116-162001f26	metal film Resistor 2.00K 1/6W ± 1% MF 26mm	1	R215
116-162492f26	metal film Resistor 24.9K 1/6W ± 1% MF 26mm	2	R257,R258
116-164320f26	metal film Resistor 432Ω 1/6W ± 1% MF 26mm	1	R265
116-166813f26	metal film Resistor 681K 1/6W ± 1% MF 26mm	1	R262
110-20152j20	Resistor 1.5K 2W ± 5% CF 20mm KINK	1	R208
113-500r1j10	cement Resistor 0.1Ω5W ± 5%	2	R224,R225
116-142003f26	metal film Resistor 200K 1/4W ± 1% MF 26mm	1	R209
<i>Capacitors</i>			
130-2b102k503	disc Capacitor 1000P 50V ± 10%	1	C165
130-3f104z503	disc Capacitor 0.1U 50V +80/-20%	2	C163,C164
130-ch101j503	disc Capacitor 100P 50V ±5%	2	C159,C160
135-3107m16	electrolytic Cap 100uF 16V ±20%	2	C166,C167
135-3226m50	electrolytic Cap 22U 50V ±20%	2	C161,C162
135-3227m10	electrolytic Cap 220U 10V ±20%	2	C156,C157
139-3227m16	low leakage ec 220uF 16V ± 20%	1	C155
140-rx103ka03	multilayer Cap 10nF 100V X7R 10%	1	C174
140-rx473kb03	multilayer Cap 47nF 200V X7R ± 10%	2	C172,C173
135-4228m35	electrolytic Cap 2200uF 35V ± 20%	2	C170,C171
135-4688m80	electrolytic Cap 6800U 80V ± 20%	2	C168,C169
<i>Semiconductors</i>			
190-161431c1p1	IC TL431CLP Shunt Regulator	1	D115
192-027c1815gr	Transistor 2SC1815GR NPN	4	Q110,112,114,117
192-028a1015gr	Transistor 2SA1015GR PNP	3	Q111,113,115
192-1572n5551	Transistor FSC 2N5551 NPN	1	Q109
192-1582n5401	Transistor FSC 2N5401 AI-PNP 350V 500mA TO-92	1	Q108
197-031n4148	diode 100mA 75V SIGNAL IN4148 ROHM	7	D118,119,120,121,125,126,117
199-15000565	ZENER diode 5.6V 1/2W 52mm	1	D116
199-15001505	ZENER diode 15V 1/2W 52mm	1	D122
199-15002005	ZENER diode 20V 1/2W 52mm	1	D129
192-991d669a	Transistor HI-SINCERITY HSD669A NPN	1	Q116
192-992b649t	Transistor HSB649T PNP	1	Q118
190-161m324n	I.C.LM324N QUAD OP-AMP	1	U107
197-00db103g	diode 1A 200V DF02M DB103G BRIDGE	1	D124
197-00kbu1003	diode 10A 200V KBU1003 BRIDGE	1	D123
197-101n4002	diode 1N4002	1	D114

Part Number	Description	Qty	Reference Designator
MAIN PCB			
<i>Miscellaneous</i>			
109-1tsc103j0	thermister TSC05103J	1	R237
162-10229004	wire assy 220mm AWG28	1	P107
171-udhss124d	relay 5A 24V UDH-SS124D	1	K101
175-1c02p01	coupling 2PIN PITCH=2.5mm	1	P108
175-1c06v01	coupling 6PIN PITCH=2.5mm	1	P105
175-1d02v01	coupling 2PIN PITCH=3.96mm	1	P112
INPUT/RABOS PCB			
<i>Resistors</i>			
110-14152j26	Resistor 1.5K 1/4W ± 5% CF 26mm	1	R150
110-16101j26	Resistor 100Ω/1/6W ± 5% CF 26mm	4	R112,R113,R151,R152
110-16102j26	Resistor 1K 1/6W ± 5% CF 26mm	2	R140,R196
110-16103j26	Resistor 1K 1/6W ± 5% CF 26mm	9	R118,126,129,133,136,146,149,199,156
110-16105j26	Resistor 1M 1/6W ± 5% CF 26mm	2	R145,R181
110-16106j26	Resistor 10M 1/6W ± 5% CF 26mm	1	R186
110-16151j26	Resistor 150Ω/1/6W ± 5% CF 26mm	1	R139
110-16154j26	Resistor 150K 1/6W ± 5% CF 26mm	1	R138
110-16183j26	Resistor 18K 1/6W ± 5% CF 26mm	1	R147
110-16203j26	Resistor 20K 1/6W ± 5% CF 26mm	1	R200
110-16221j26	Resistor 220Ω/1/6W ± 5% CF 26mm	2	R119,R120
110-16223j26	Resistor 22K 1/6W ± 5% CF 26mm	2	R141,R148
110-16472j26	Resistor 4.7K 1/6W ± 5% CF 26mm	1	R144
110-16473j26	Resistor 47K 1/6W ± 5% CF 26mm	1	R137
110-16474j26	Resistor 470K 1/6W ± 5% CF 26mm	1	R143
110-164r7j26	Resistor 4.7Ω/1/6W ± 5% CF 26mm	1	R153
116-161000f26	metal film Resistor 100Ω/1/6W ± 1% MF 26mm	1	R154
116-161001f26	metal film Resistor 1K 1/6W ± 1% MF 26mm	12	R130,131,132,159,160,166,171,173,178,192,114,115
116-161103f26	metal film Resistor 100K 1/6W ± 1% MF 26mm	1	R174
116-161502f26	metal film Resistor 15.0K 1/6W ± 1% MF 26mm	2	R162,R168
116-161504f26	metal film Resistor 1.5M 1/6W ± 1% MF 26mm	1	R142
116-161622f26	metal film Resistor 16.2K 1/6W ± 1% MF 26mm	1	R188
116-161742f26	metal film Resistor 17.4K 1/6W ± 1% MF 26mm	4	R124,R125,R127,R128
116-162001f26	metal film Resistor 2.00K 1/6W ± 1% MF 26mm	1	R202
116-162052f26	metal film Resistor 20.5K 1/6W ± 1% MF 26mm	2	R197,R198
116-162211f26	metal film Resistor 2.21K 1/6W ± 1% MF 26mm	1	R172
116-162212f26	metal film Resistor 22.1K 1/6W ± 1% MF 26mm	3	R193,R204,R206
116-162671f26	metal film Resistor 2.67K 1/6W ± 1% MF 26mm	1	R155
116-163323f26	metal film Resistor 332K 1/6W ± 1% MF 26mm	1	R195
116-163400f26	metal film Resistor 340Ω/1/6W ± 1% MF 26mm	2	R164,R169
116-163571f26	metal film Resistor 3.57K 1/6W ± 1% MF 26mm	1	R157
116-163923f26	metal film Resistor 392K 1/6W ± 1% MF 26mm	1	R201
116-164751f26	metal film Resistor 4.75K 1/6W ± 1% MF 26mm	2	R109,R110
116-164752f26	metal film Resistor 47.5K 1/6W ± 1% MF 26mm	2	R121,R122
116-164992f26	metal film Resistor 49.9K 1/6W ± 1% MF 26mm	1	R135
116-165231f26	metal film Resistor 5.23K 1/6W ± 10% MF	2	R205,R207
116-165232f26	metal film Resistor 52.3K 1/6W MF 26mm	1	R190
116-165400f26	metal film Resistor 540Ω/1/6W MF 26mm	1	R175
116-166041f26	metal film Resistor 6.04K 1/6W ± 1% MF 26mm	2	R165,R170
116-166800f26	metal film Resistor 680Ω/1/6W ± 1% MF 26mm	1	R176
116-168250f26	metal film Resistor 825Ω/1/6W ± 1% MF 26mm	2	R161,R167
116-168661f26	metal film Resistor 8.66K 1/6W ± 1% MF 26mm	1	R134
116-169311f26	metal film Resistor 9.31K 1/6W ± 1% MF 26mm	2	R189,R179
115-h103a101	variable Resistor A10K LEVEL	1	R259
115-h103a203	variable Resistor RV16A01-20-15K-A10K-3E RABOS LEVEL, RABOS WIDTH	2	R158,R177
115-h103c201	variable Resistor RV16A01-20-15K-C10K-3E RABOS FREQ.	1	R163

Part Number	Description	Qty	Reference Designator
INPUT/RABOS PCB			
<i>Capacitors</i>			
129-a102j633	metalized Capacitor 0.001uF 63V ± 5% MSC	1	C148
129-a103j633	metalized Capacitor 10NF 63V	1	C183
129-a104j633	metalized Capacitor 0.1U 63V ± 5% MSC	6	C116,137,138,139,143,118
129-a223j633	metalized Capacitor 0.022U 63V ± 5% MSC	1	C150
129-a224j633	metalized Capacitor 0.22uF 63V ± 5% MSC	2	C121,C122
129-a473j633	metalized Capacitor 0.047U 63V ± 5% MSC	3	C117,C119,C149
130-2b102k503	disc Capacitor 1000P 50V ± 10%	2	C181,C182
130-2b221k503	disc Capacitor 220P 50V ± 10%	3	C107,C108,C128
130-3f104z503	disc Capacitor 0.1U 50V +80/-20%	13	C112,114,124,125,130,133,135,144,145,146,147,153,154
130-3f473m503	disc Capacitor 0.047U 50V ± 20%	1	C180
130-sl101k503	disc Capacitor 100P 50V SL ± 10%	2	C110,C120
130-s1470k503	disc Capacitor 47P 50V ± 10%	1	C127
135-3105m50	electrolytic Cap 1U 50V ± 20%	1	C126
135-3106m50	electrolytic Cap 10uF 50V ± 20%	4	C109,C111,C123,C129
135-3107m16	electrolytic Cap 100uF 16V ± 20%	5	C113,115,132,134,136
135-3107m25	electrolytic Cap 100U 25V ± 20%	1	C152
135-3226m50	electrolytic Cap 22U 50V ± 20%	1	C151
139-3227m16	low leakage electrolytic Cap 220uF 16V ± 20%	1	C131
129-a683j633	metalized Capacitor 0.068uF 63V ± 5% MSC	1	C142
<i>Semiconductors</i>			
192-027c1815gr	Transistor 2SC1815GR NPN	3	Q101,Q102,Q103
197-031n4148	diode 100mA 75V SIGNAL IN4148 ROHM	7	D105,106,108,109,110,112,113
199-15000825	zener diode 8.2V 1/2W 52mm	1	D130
190-06m4558d	IC.0PA 4558D DUAL OP-AMP	2	U101,U103
190-16TL1072N	I.C. TL072N DUAL OP-AMP	1	U105
190-16t1074cn	I.C TL074CN ST QUAD OP-AMP	3	U102,U104,U106
192-153mpf102	I.C FAIRCHILD MPF102 FET	1	Q107
<i>Miscellaneous</i>			
180-t000ts81	TACT switch L101 T2 LO-PASS,PHASE,RABOS	3	SW102,SW103,SW104
174-0rcb202vag	RCA JACK RCA-209	1	JK102
175-1c02p01	coupling 2PIN PITCH=2.5mm	2	P106,P101
Power Amp Class D Module part# 051-A00444C01 RECOMMENDED: REPLACE ENTIRE MODULE			
<i>Resistors</i>			
118-12061001j	SMD Resistor 1.00K 1206 5%	1	R2
118-12061002j	SMD Resistor 10.0K 1206 5%	6	R25,29,30,30B,7,9
118-120610r0j	SMD Resistor 10.0Ω 1206 5%	4	R20,R20B,R22,R23
118-12062002j	SMD Resistor 20.0K 1206 5%	1	R26
118-12062201j	SMD Resistor 2.20K 1206 5%	19	R6,13,16,31,33,34,34,35,37,38,39,40,41,42,43,44,45,46,32
118-12062204j	SMD Resistor 2.20M 1206 5%	1	R4
118-12062701j	SMD Resistor 2.70K 1206 5%	1	R10
118-12063000j	SMD Resistor 300.0Ω 1206 5%	1	R24
118-12063301j	SMD Resistor 3.30K 1206 5%	5	R1,14,15,27,28
118-12063902j	SMD Resistor 39.0K 1206 5%	1	R3
118-12064700j	SMD Resistor 470Ω 1206 5%	3	R8,R11,R21
118-12064701j	SMD Resistor 4.70K 1206 5%	2	R5,R12
112-10180j00	fusible Resistor FMF 1W 18Ω5%	1	
<i>Capacitors</i>			
141-c0101k50	SMD Capacitor 100pF 50V 10% 1206 NP0	1	C4
141-c0220k50	SMD Capacitor 22pF 50V 10% 1206 SMT NP0	1	C5
141-c0561k50	SMD Capacitor 560pF 50V 10% 1206 NP0	1	C6
141-c5104m50	SMD Capacitor 1206 Y5V 0.1uF 50V±20%	8	C2,3,7,8,9,10,11,15

Part Number	Description	Qty	Reference Designator
CLASS D AMP PCB			
141-c7223k50	SMD Capacitor 0.022uF 50V 10% 1206 X7R	1	C13
141-d7104ka0	SMD Capacitor 0.1uF 100V 10% 1210 X7R	4	C12,C14,C18,C19
130-s1681kb03	disc Capacitor SL 680PF 200V	1	
132-104kb50	mylar Capacitor 0.1U±10% 250V LS-10.mm MD	1	C20
132-105kb50	mylar Capacitor 1uF 250V ±10%	1	C40
<i>Semiconductors</i>			
190-16t1072dts	SMD I.C.TL072CDT SGS THOMSON DUAL OP-AMP	1	IC1
192-09124126qs	SMD Transistor 2SC2412K-T146Q/R ROHM	2	Q1,Q4
192-09139066rs	SMD Transistor 2SC3906K-T146R ROHM	2	Q2,Q8
192-091sc4672	Transistor 2SC4672(MPT3)ROHM	1	Q5B
192-09210376qs	SMD Transistor 2SA1037K-T146Q/R ROHM	2	Q7,Q9
192-09215146rs	SMD Transistor 2SA1514K-T146R ROHM	1	Q3
192-1582n5401	Transistor FSC 2N5401 AI-PNP 350V 500mA TO-92	1	Q6B
197-03r1s4148s	SMD diode RLS4148-TE11 ROHM	8	D1,2,3,4,5,5B,6,20
199-15000563s	SMD ZENER 5.6V 5% PHILIPS BZX84-C5V6	2	Z1,Z2
199-15001203s	SMD ZENER 12V 5% PHILIPS BZX84-C12	4	Z3,Z4,Z5,Z6
192-232irf9640	Transistor FET IRF9640 IR P-CH TO220	2	Q10,Q10B
192-233f640n	Transistor FET IRF640n INTERNATIONAL	1	Q11
<i>Miscellaneous</i>			
122-13151k0190	CHOKE SA-500-280(PT1601B*151MAA)	1	L1
122-14300k4	Ferrite core LD1215*300KU±10%	1	L2
128-e106ma01-s	non-polar ec 10uF 100V 20%	2	C16,C17
175-9f40hr2	coupling 40PIN PITCH=2.54mm HR2*40	0.2	
MISCELLANEOUS			
150-r1107008	power transformer TT093040561A	1	T01
152-u602015	line cord SVTFT-2 6FT	1	
154-k31505t0	Fuse 3.15a 250v 30mm UL/CSA/PSE	1	F01
155-630r345b	fuse holder UL/CSA φ6*30mm	1	for F01
162-10100023	WIRE UL/CSA 1617#22 100mm BLK	1	
162-1035d001	wire 1015#16 BRN/WHT 350mm 2PIN	1	
162-1035d002	wire 1015#16 BLK/YEL/RED 350mm 6PIN	1	
162-50259004	wire 250mm AWG24	1	P108
162-5035d003	wire 2468#26AWG 2PIN RED/BLK 350mm	1	
163-11009	wire 100mm	4	
166-5070a4fd	speaker wlre 700mm #18 UL1015 #205*0.5t/#250*0.8t	1	
176-wjce2	wire connector &Base CE-2	1	
180-prf1003b	Switch ROCK RF-1003-BB210 POWER	1	
193-0s4211	INSULATOR(INSULATION SPACER)42*11	1	
193-201612tr	INSULATOR T0-220 16mm*12mm	1	
193-201815t2	INSULATOR	2	

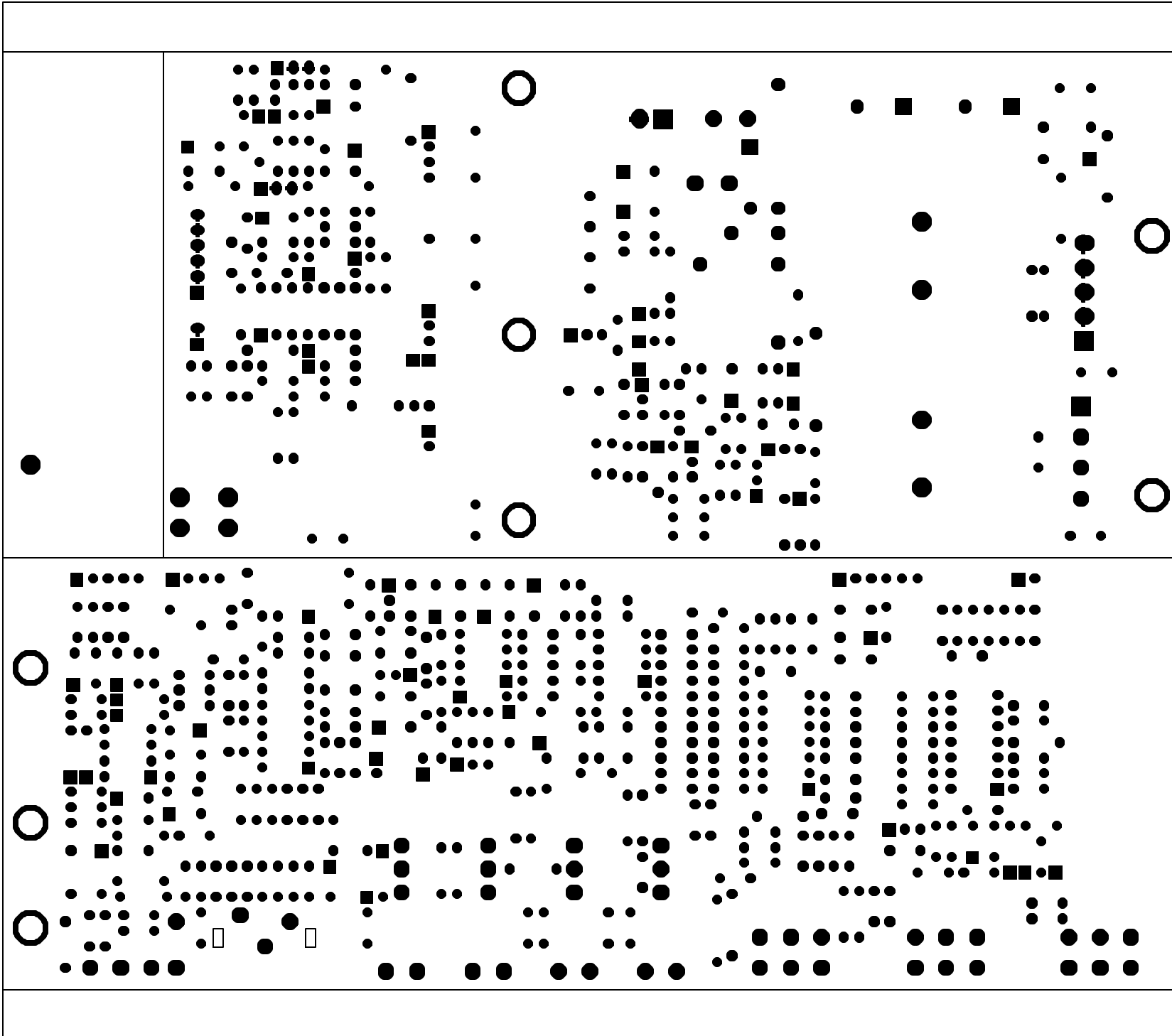

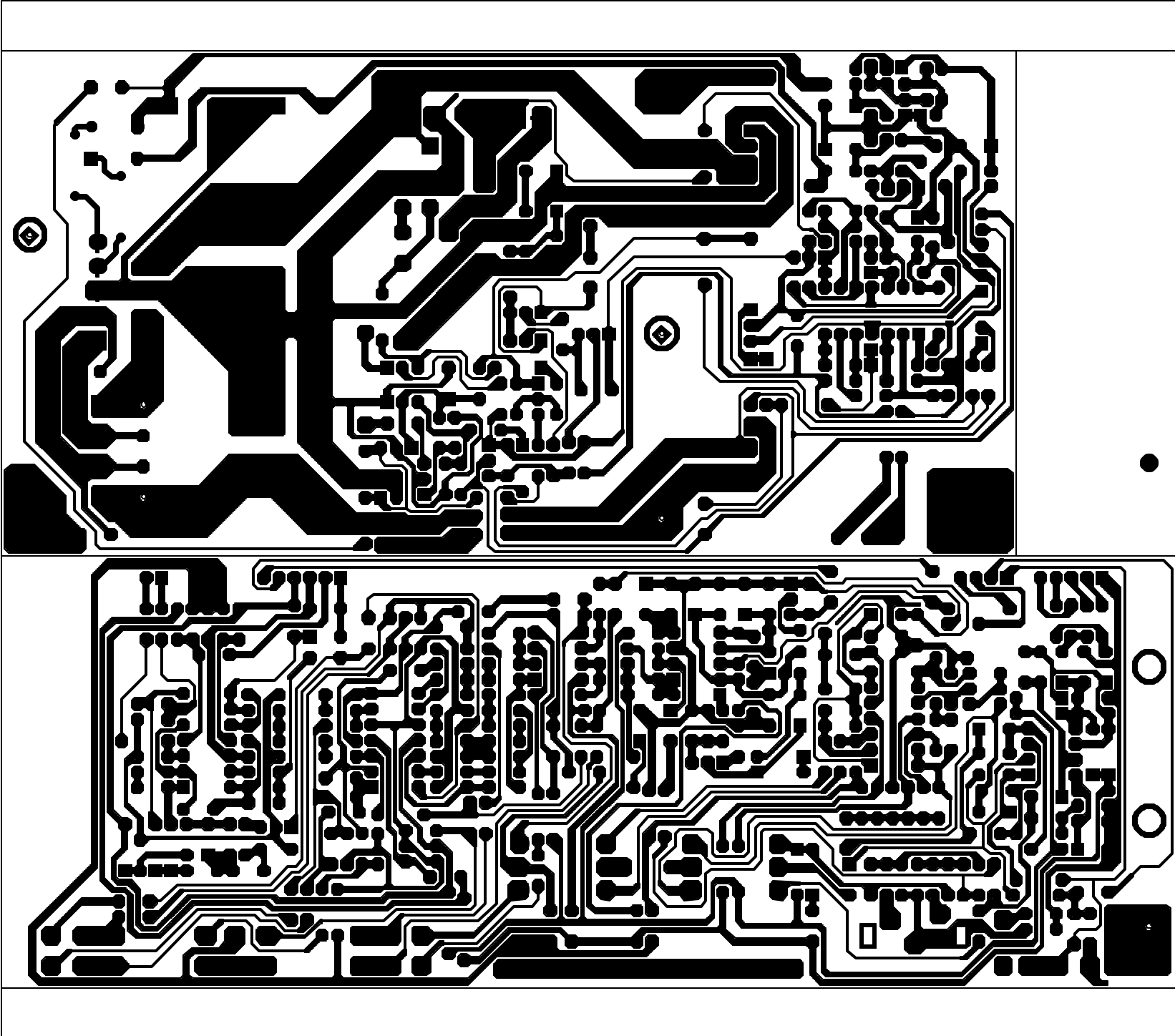

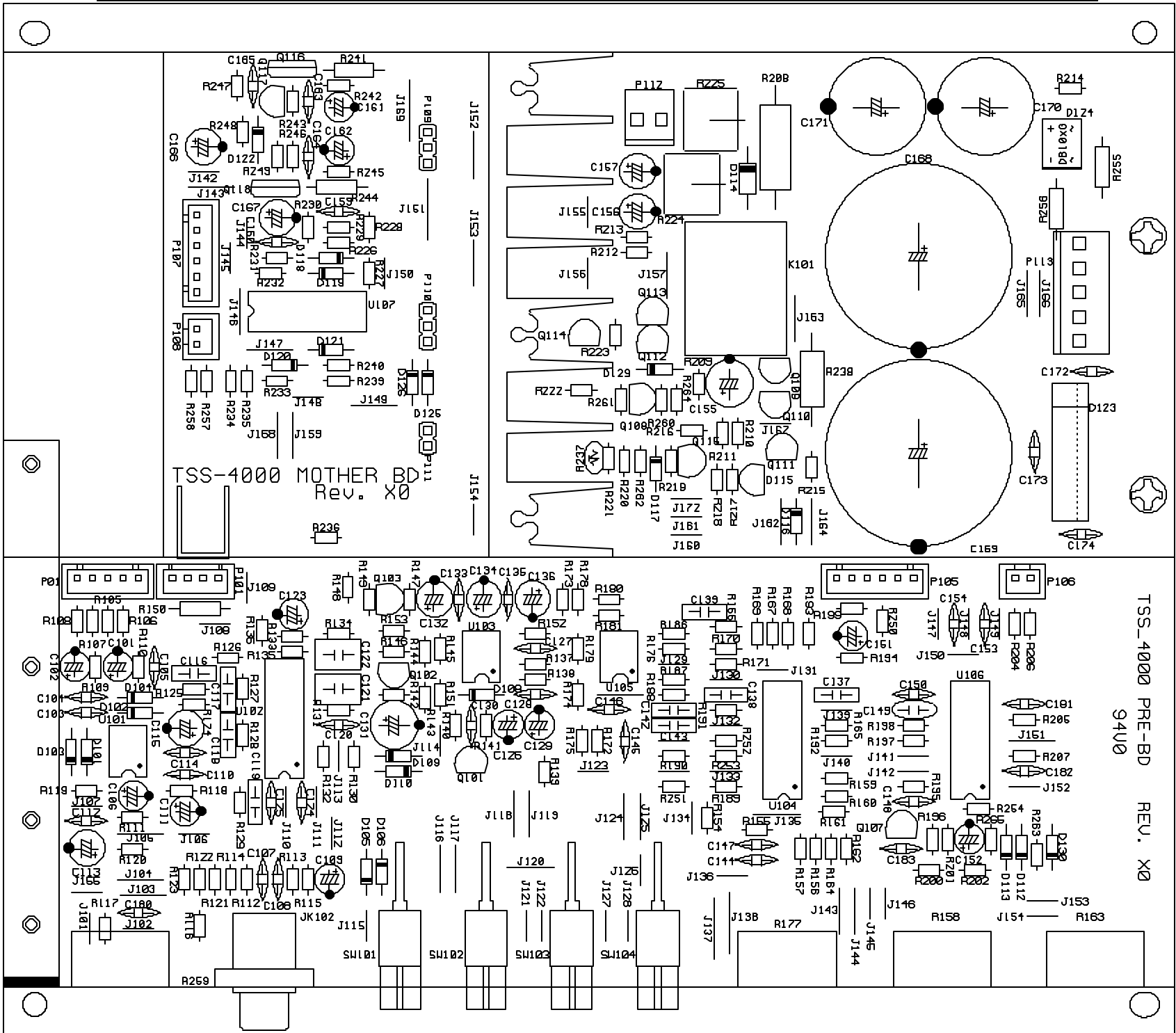

Integrated Circuit Diagrams

4558, TL072 DUAL OP-AMP
IC1, U101,103,105

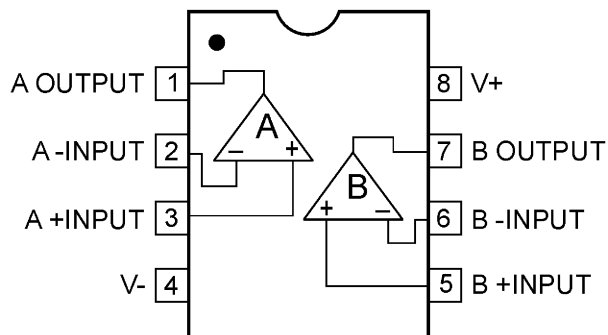

OPAMP,
QUAD 14P DIL TL074 LM324
U102, 104, 106, 107

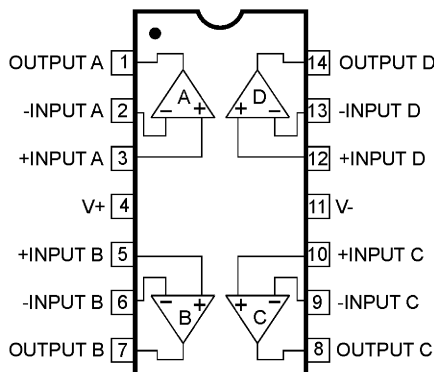

TL431CLP
D115



1. Cathode
2. Anode
3. Reference

2N5401
Q6B, 108

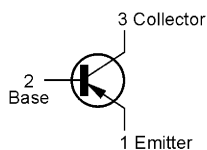
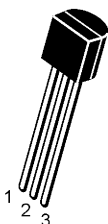

- 2SC2412K
- 2SC3906K
- 2SC4672K
- 2SA1037K

Q1-4, 5B, 7, 8, 9

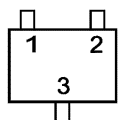

- 1) Emitter
- 2) Base
- 3) Collector

MOSFET IRF640, 9640
Q10,10B,11

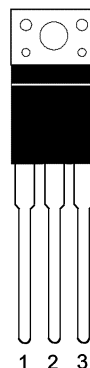

1. G
2. D
3. S

MPF102
Q107

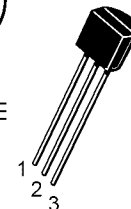
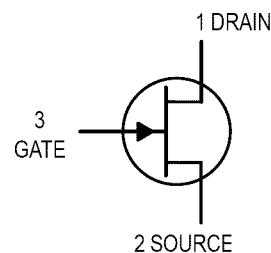

2N5551
Q109

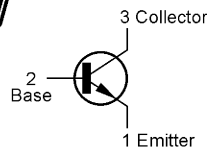
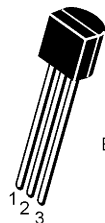

2SA1015
Q111,113,115

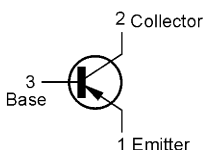
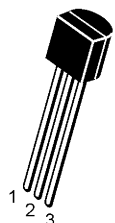

HSD669A, HSB649A
Q116,118

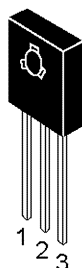

1. Emitter
2. Collector
3. Base

2SC1815
Q101,102,103,110,112,114,117

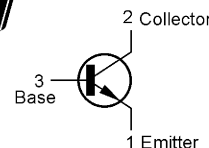

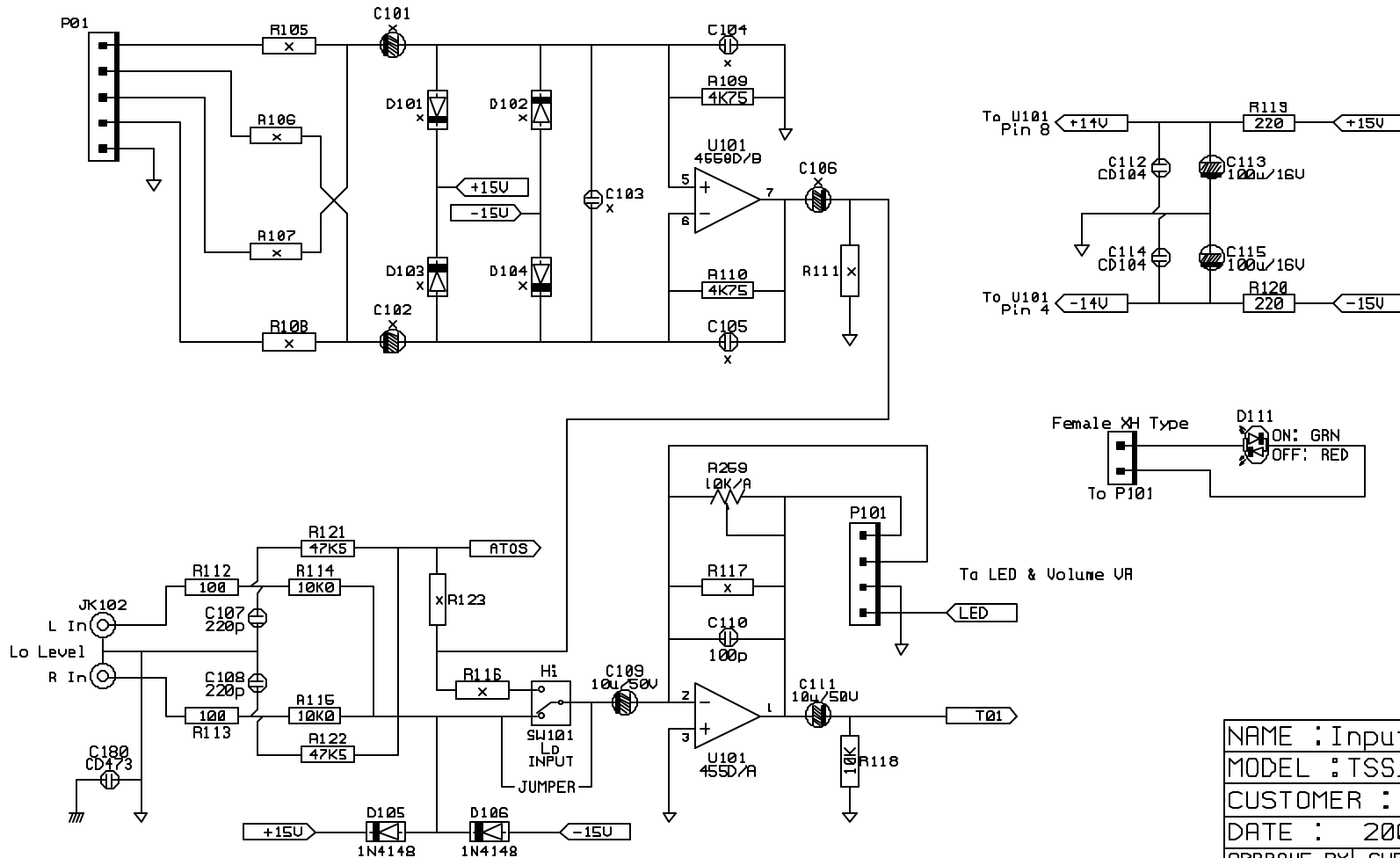

NAME : Input/PRE	1/10
MODEL : TSS_4000	REV: 1
CUSTOMER : Infinity	
DATE : 2004-12-13	
APPROVE BY	CHECK BY DRAWING BY

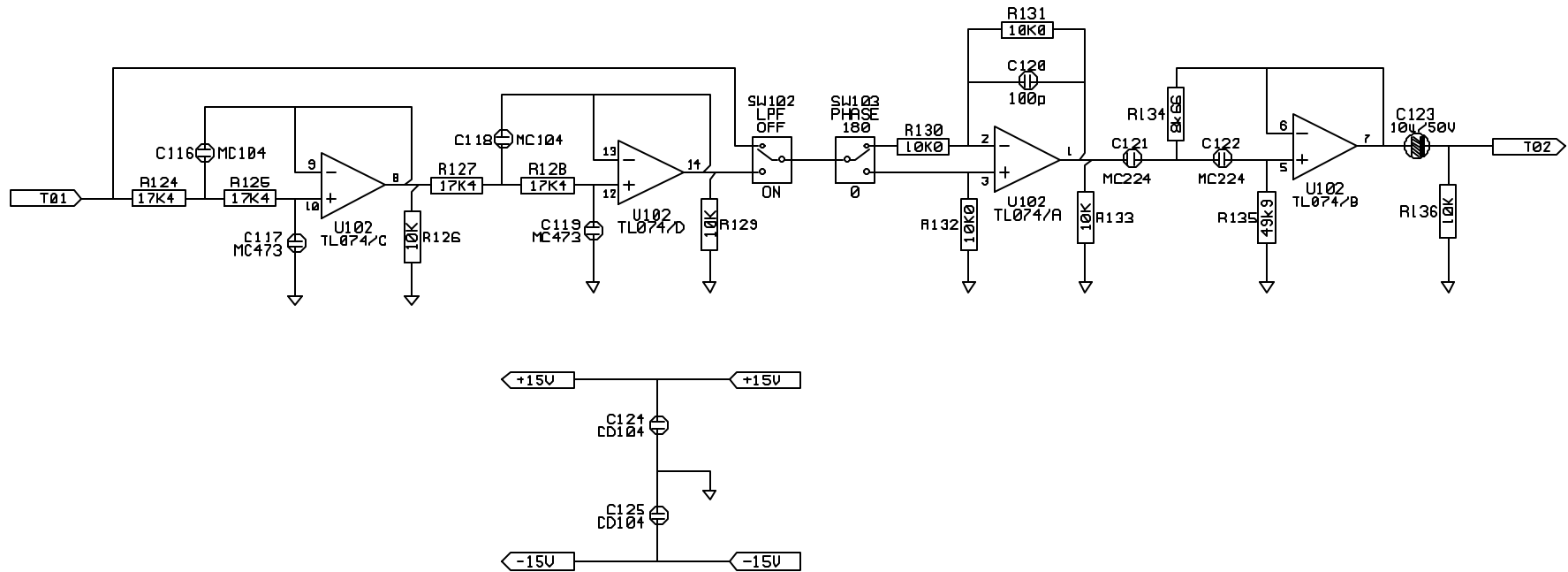

NAME : Filter/PRE	2/10
MODEL : TSS_4000	REV:1
CUSTOMER : Infinity	
DATE : 2004-12-13	
APPROVE BY	CHECK BY DRAWING BY

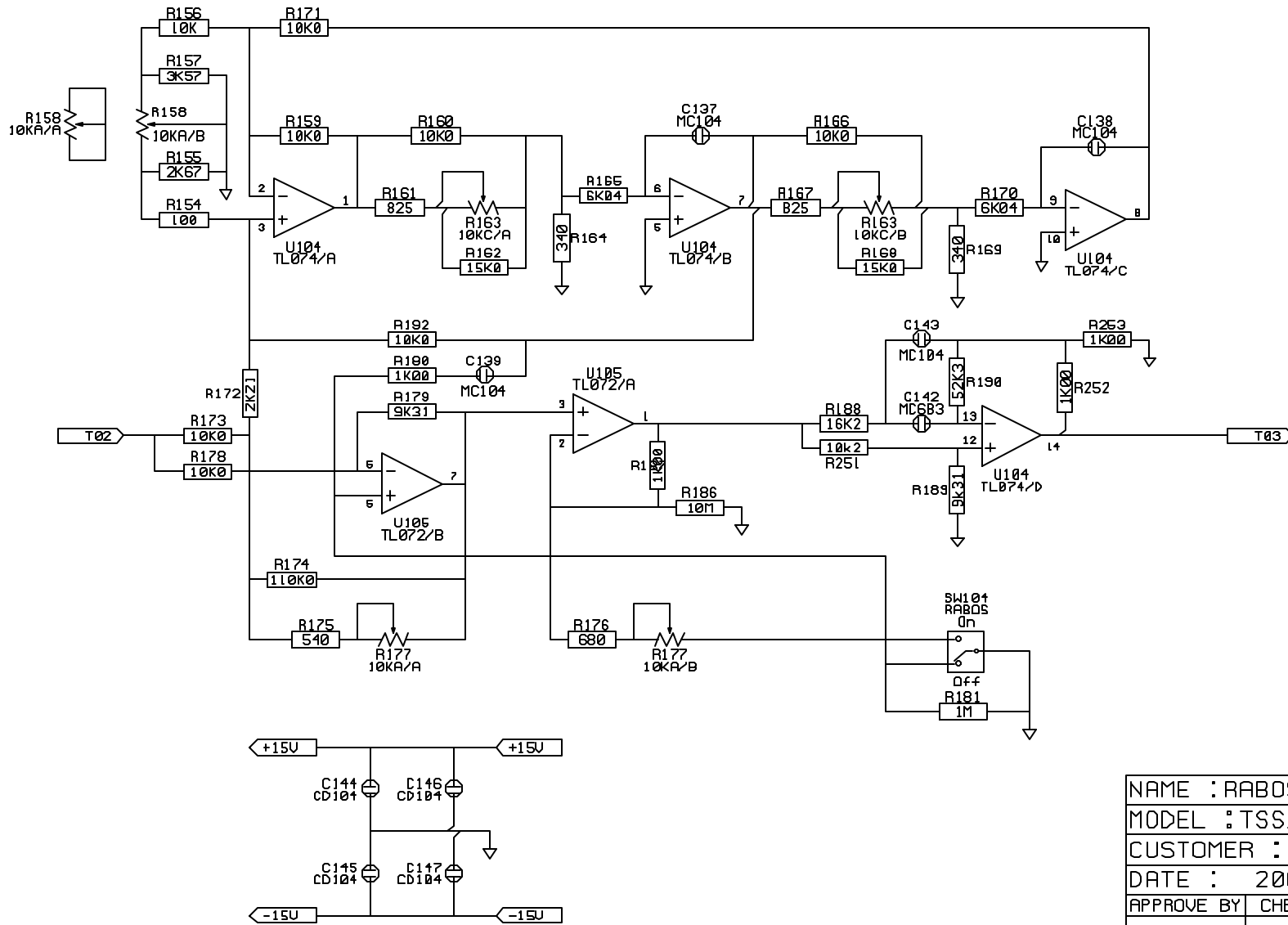

NAME : RABOS/PRE	3/10
MODEL : TSS_4000	REV: 1
CUSTOMER : Infinity	
DATE : 2004-12-13	
APPROVE BY	CHECK BY DRAWING BY

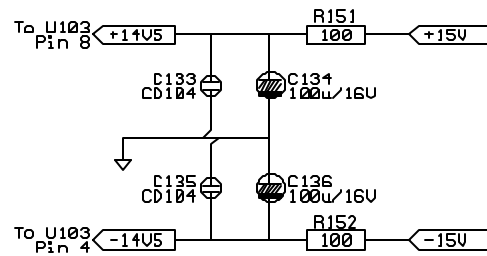
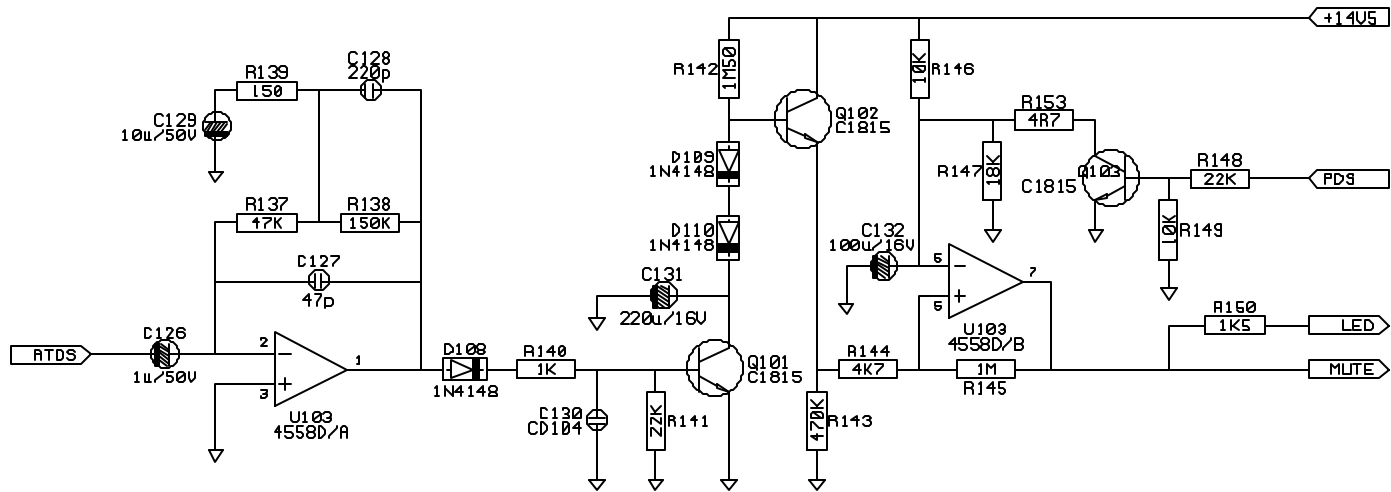

NAME :Auto ON/PRE	4/10
MODEL :TSS_4000	REV:1
CUSTOMER : Infinity	
DATE : 2004-12-13	
APPROVE BY	CHECK BY DRAWING BY

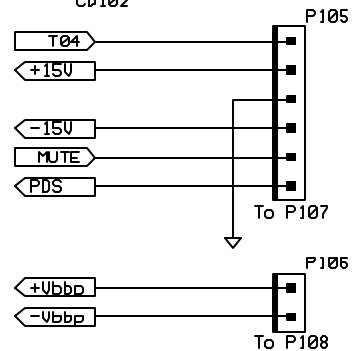
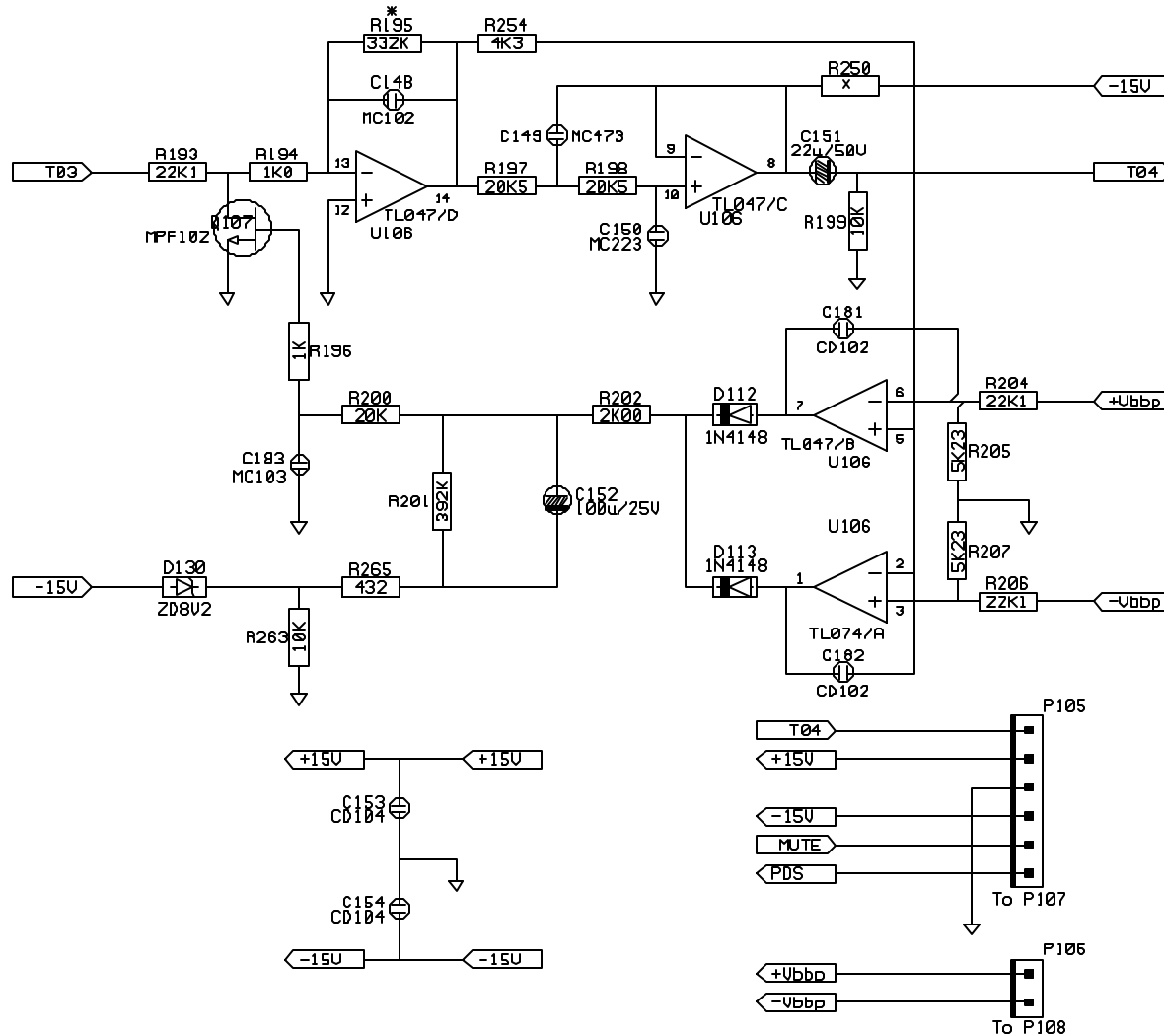

NAME :Limiter/PRE	5/10
MODEL :TSS_4000	REV:1
CUSTOMER : Infinity	
DATE : 2004-12-13	
APPROVE BY	CHECK BY DRAWING BY

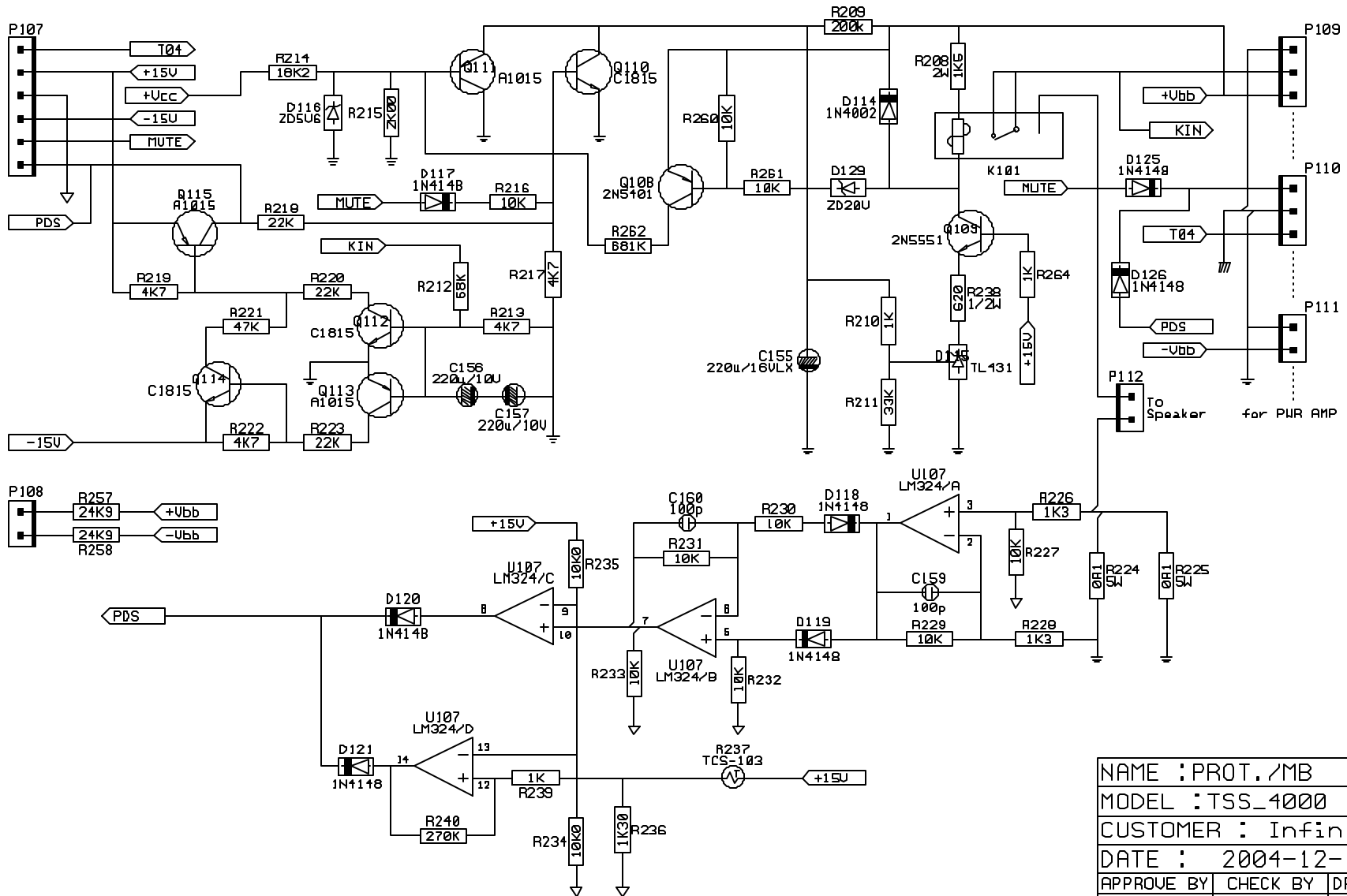

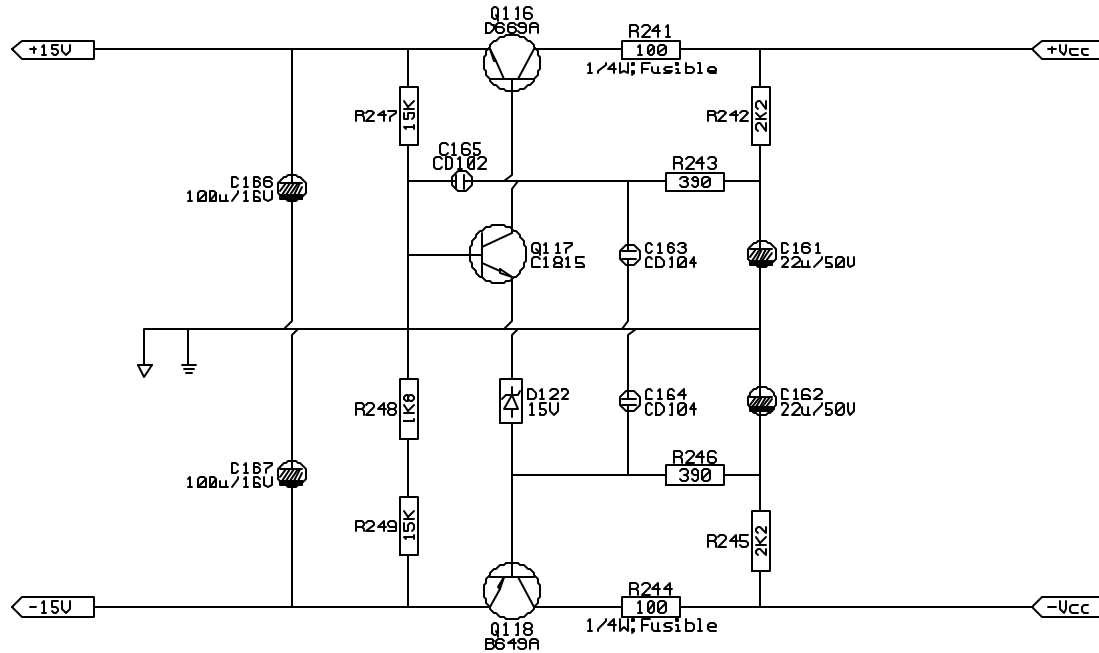

NAME : PN15V/MB	7/10
MODEL : TSS_4000	REV: 1
CUSTOMER : Infinity	
DATE : 2004-12-13	
APPROVE BY	CHECK BY DRAWING BY

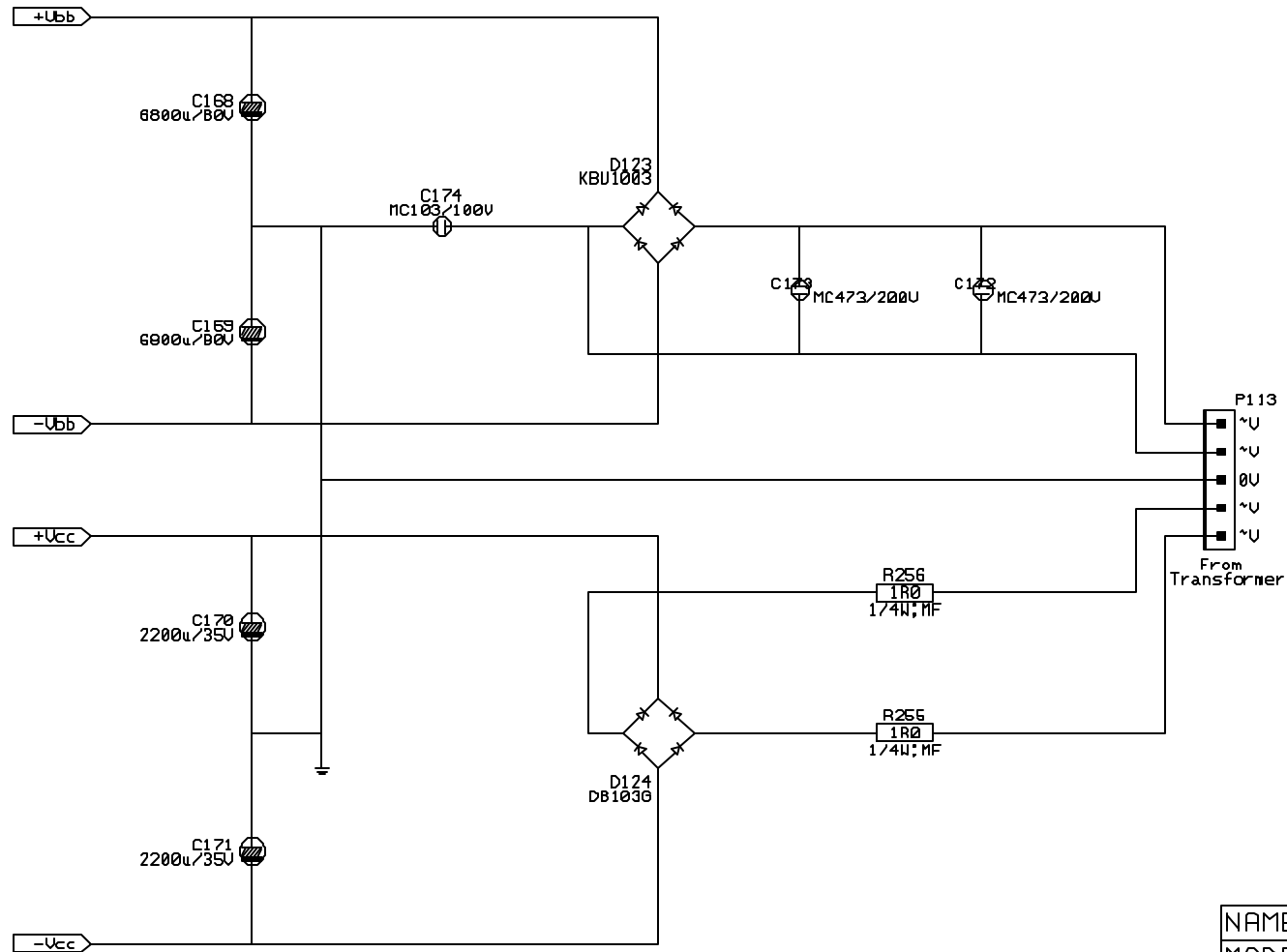

NAME : DC Power/MB	8/10
MODEL : TSS_4000	REV: 1
CUSTOMER : Infinity	
DATE : 2004-12-13	
APPROVE BY	CHECK BY
DRAWING BY	

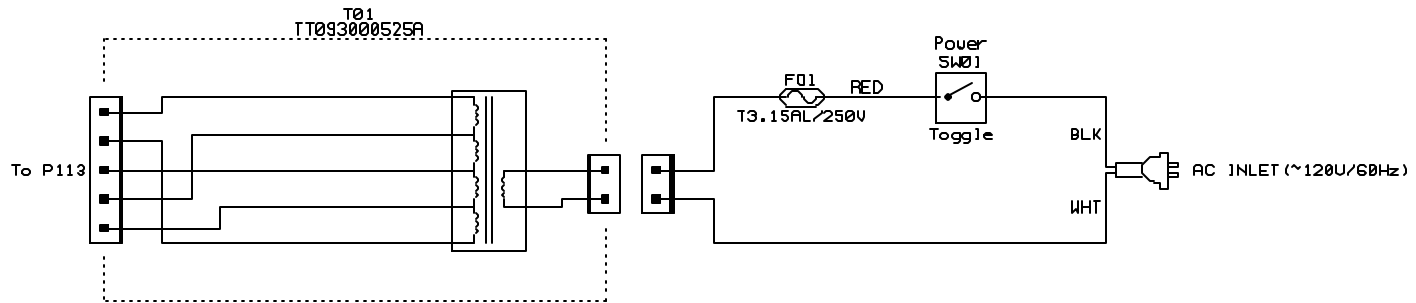

NAME : AC INLET	9/10
MODEL : TSS_4000	REV: 1
CUSTOMER : Infinity	
DATE : 2004-12-13	
APPROVE BY	CHECK BY
DRAWING BY	

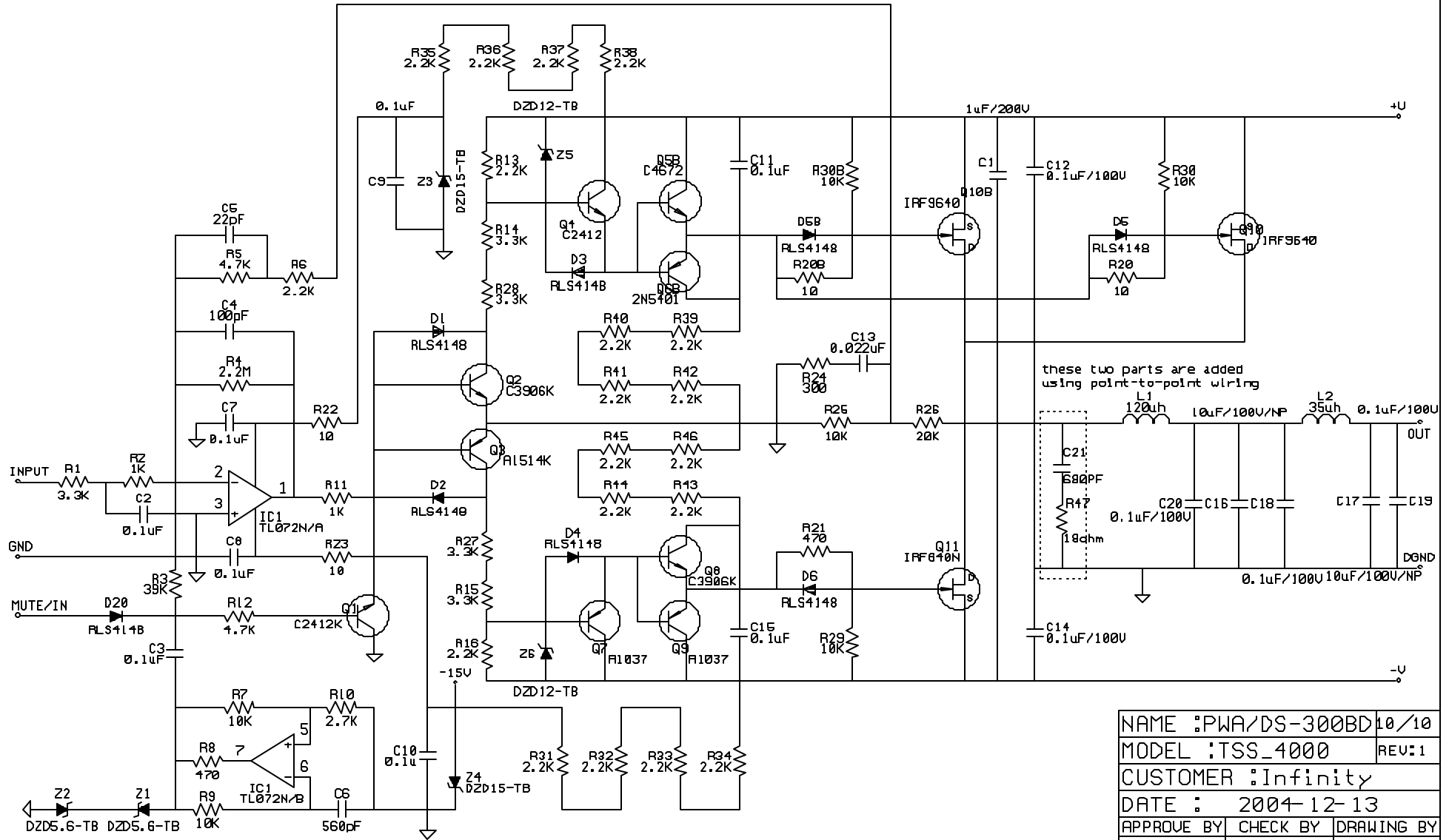

NAME :PWA/DS-300BD	10/10
MODEL :TSS_4000	REV:1
CUSTOMER :Infinity	
DATE : 2004-12-13	
APPROVE BY	CHECK BY DRAWING BY

PACKAGE

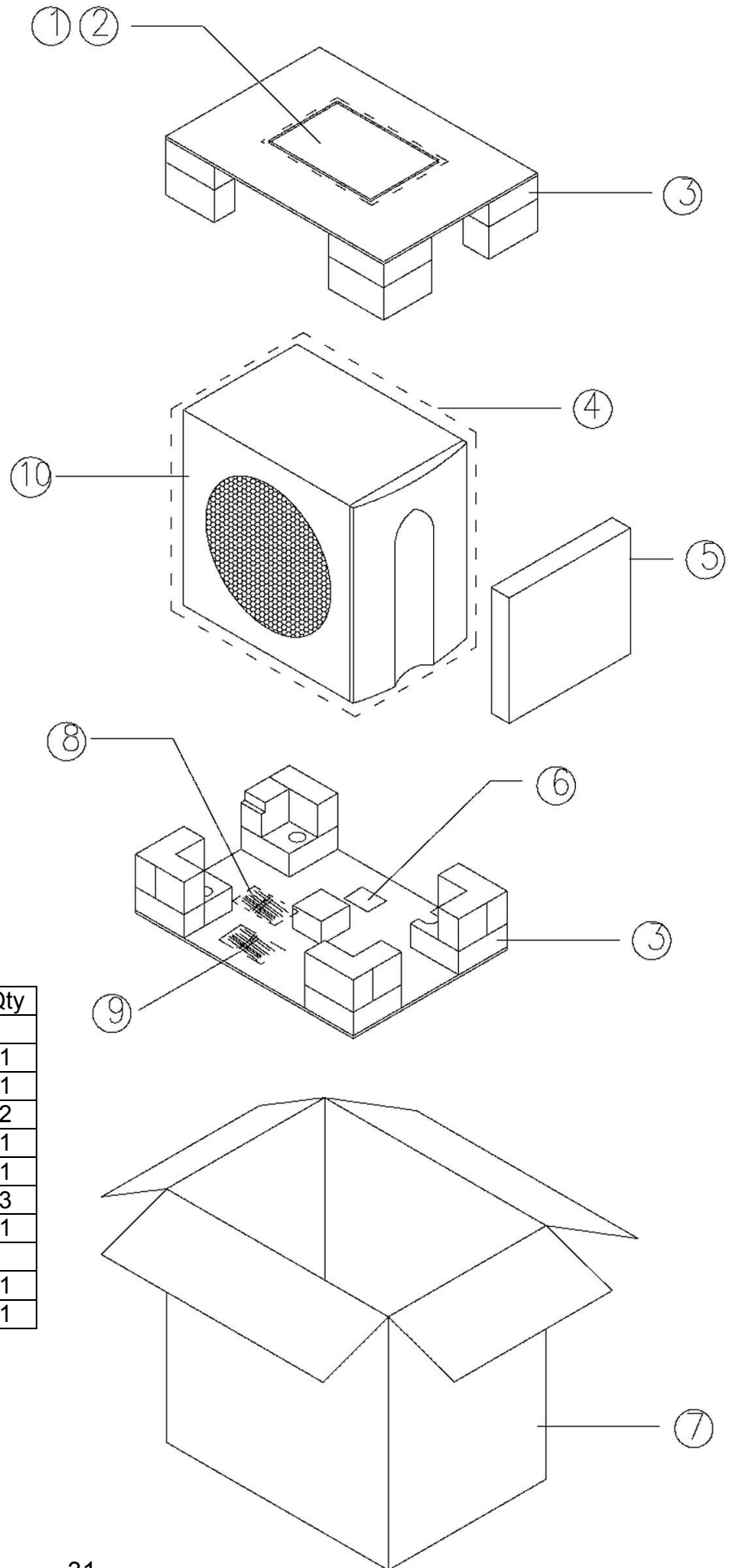

Ref #	Description	Part Number	Qty
1	Owner's Manual	406-000-05133	1
2	Warranty Card	405-000-00328	1
3	Top/Bottom Packing	431-000-05293	2
4	Plastic Bag		1
5	RABOS Kit	335852-003	1
6	Silica Gel		3
7	Outer Carton	402-000-05237	1
8	n/a		
9	15ft. RCA cable	166-015F011	1
10	TSS-SUB4000	TSS-SUB4000PLT	1