

XTI-300

Service manual



SPECIFICATIONS:

General Section

- Frequency Response: 25Hz - 130Hz
- Built-in Amplifier: 300 Watts Class D
- Crossover Frequency: 40Hz - 130Hz, 24dB/octave
- Low-Frequency Driver: 12" Poly laminate
- Input / Outputs: Line- and high-level
- Finish: Beech or Brown Cherry Real Wood Veneer
- Dimensions (H x W x D): 550mm x 410mm x 500mm
- Weight: 28kg

JBL XTI-300 SUB

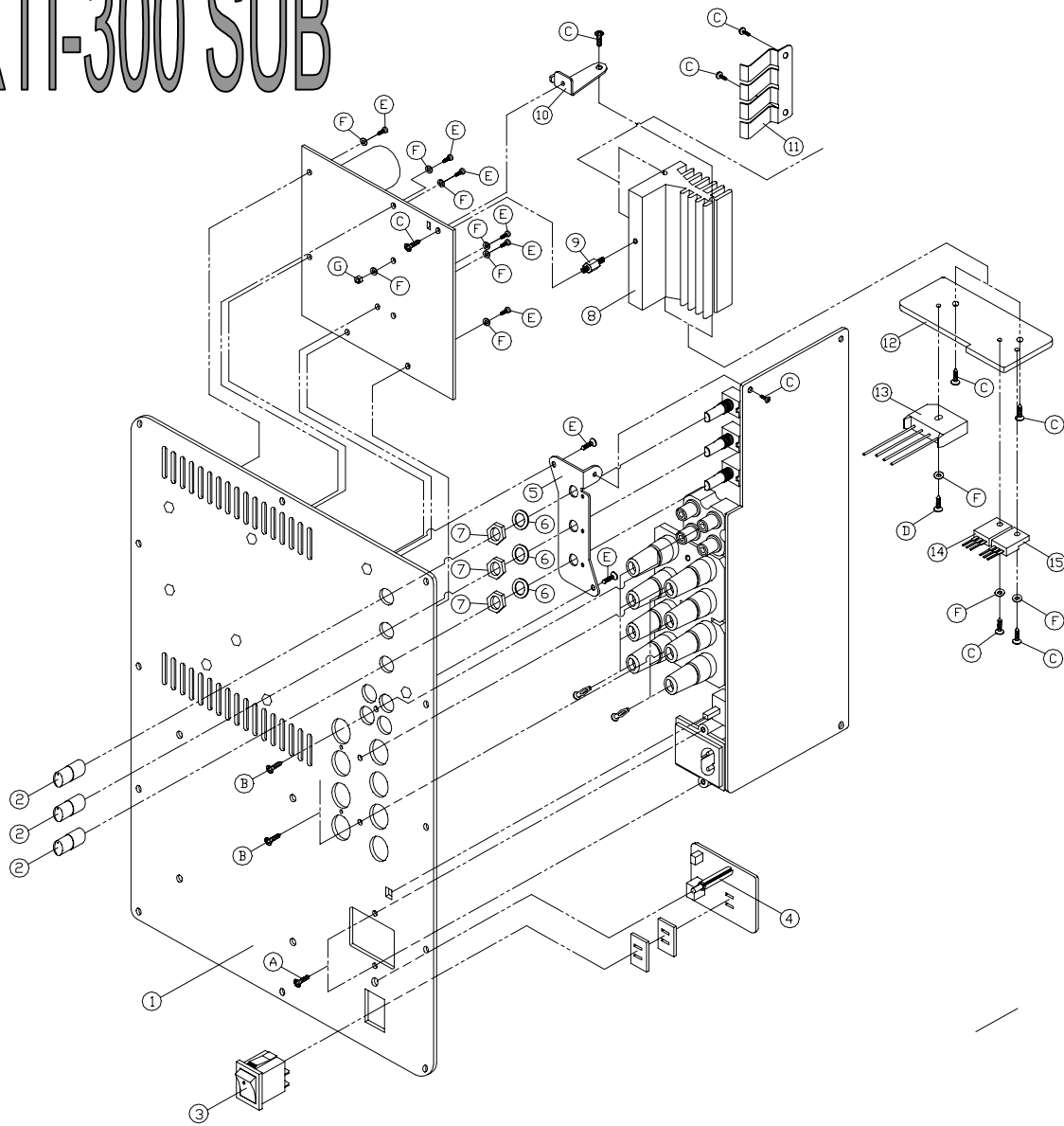

G	NUT-HEXAGON	XNHB-03000-ZY0	1	HEX-SM3*0.5 FE-ZY
F	WASHER-FLAT(3.0)	MMAC-15380-ZZ4	10	AK-10
E	SCREW-MACHINE	MMAC-16860-004	8	M3x6 pi0.5 Cr
D	SCREW-TAPPING	XSTB-30120-ZY4	1	BHT2T 3x12 FE-ZY
C	SCREW-TAPPING	XSTB-30080-ZY4	9	BHT2T 3x8 FE-ZY
B	SCREW-T/P-TOOTH	MMAC-16400-004	3	3x10 BLACK
A	SCREW-TAPPING	XSTB-30100-ZB4	2	BHT2T 3x10 FE-ZB
16	CORK-TERMINAL	MJAG-13060-ZZ4	8	ABS HF-380
15	IC-REGULATOR	ICRG-00440-SG0	1	NJM7912FA
14	IC-REGULATOR	ICRG-01110-SG0	1	NJM7812FA
13	BRIDGE-RECTIFER	DD4B-00340-TB0	1	BU8-06
12	HEAT-SINK-TR2	MEAC-16820-004	1	Alp t3.0
11	BRACKET-TR	MPAC-16800-004	1	SUS-304 t0.5
10	BRACKET-HEAT SINK	MPAC-16810-004	1	SECC t1.0
9	SCREW-HEAT SINK	MMAC-16830-004	1	AK-10 Cr
8	HEAT-SINK-TR1	MEAC-05000-003	1	A6063 T-5
7	NUT		3	M7
6	WASHER		3	M7
5	BRACKET-VOLUME	MPAC-16790-004	1	SECCt1.0
4	SUPPORT-LED	MRAG-13710-004	1	RUBBER 18.5m/m
3	LOCKER-SWITCH	SWVS-00120-S40	1	R13-73A-09
2	KNOB-ROTARY	MJAF-15420-ZZ4	3	ABS-720
1	PANEL-BACK	MPAC-04990-ZZ2	1	SECCt2.0
No	PARTS NAME	CODE No	Q,TY	REMARK

BILL OF MATERIAL(MASTER P/L)

MODEL CODE: 91AM-K1000-01E MODEL NAME: AMP-250

BUYER: JBL

DESTINATION: EUROPE

Date: 2002.03.18

ASS'Y CODE	PARTS CODE	DESCRIPTION	SPECIFICATION	Q'TY	Loc. No
Ass'y Mecha					
A2AMK1000A1E	DD4B00340TB0	BRIDGE RECTIFER	BU8-06	1	BR1
A2AMK1000A1E	FGFBS2002837	FUSE GLASS	2A 250V 50T	1	F101
A2AMK1000A1E	FIBA00020S6V	FUSE-COVER	L-A20	1	
A2AMK1000A1E	ICRG00440SG0	IC REGULATOR	NJM7912FA TO-220	1	
A2AMK1000A1E	ICRG01110SG0	IC REGULATOR	NJM7812FA 12V	1	
A2AMK1000A1E	MEAC05000003	HEAT SINK-TR1	A6063 T-5	1	
A2AMK1000A1E	MEAC16820004	HEAT SINK-TR2	ALP T3.0	1	
A2AMK1000A1E	MJAF15420024	KNOB-ROTARY	AMP 250 ABS-720	3	
A2AMK1000A1E	MJAG13060014	CORK-TERMINAL	AVR100READY ABS HF-380	8	
A2AMK1000A1E	MMAC15380014	WASHER-FLAT(3.0)	A-900	10	
A2AMK1000A1E	MMAC16400004	SCREW-T/P-TOOTH	3X10 BLACK	3	
A2AMK1000A1E	MMAC16830004	SCREW-HEAT SINK	AK-10 CR	1	
A2AMK1000A1E	MMAC16860004	SCREW-MACHINE	M3*6*PI0.5 CR WHITE	8	
A2AMK1000A1E	MPAC04990012	PANEL-BACK	AMP 250 SECC T1.6 SPR	1	
A2AMK1000A1E	MPAC16790004	BRACKET-VOLUME	SECC T1.0	1	
A2AMK1000A1E	MPAC16800004	BRACKET-TR	SUS-304	1	
A2AMK1000A1E	MPAC16810004	BRACKET-HEAT SINK	SECC T1.0	1	
A2AMK1000A1E	PTAN03740YJV	POWER TRANSFORMER	A86-374Y-V(250V 50Hz)	1	
A2AMK1000A1E	XNHB03000ZY0	NUT-HEXAGON	HEX-SM3*0.5 FE-ZY	1	
A2AMK1000A1E	XSTB30080ZY4	SCREW-TAPPING	BHT2T 3x8 FE-ZY	9	
A2AMK1000A1E	XSTB30100ZB4	SCREW-TAPPING	BHT2T 3x10 FE-ZB	2	
A2AMK1000A1E	XSTB30120ZY4	SCREW-TAPPING	BHT2T 3x12 FE-ZY	1	
A2AMK1000A1E	XSTB40080ZB8	SCREW-TAPPING	BHT3T 4x8 FE-ZB	4	
A2AMK1000A1E	YGAP15350014	BOX-GIFT	AMP 250 DW-2 533*473*3	0.125	
A2AMK1000A1E	YSAP01650001	CUSHION	EPS 530*470*195	0.25	
A2AMK1000A1E	YVAP15360014	POLY-BAG	AMP 250 PE-LD 390*360*	1	
A2AMK1000A1E	KDAC0012EPA8	CORD-AC	KKP-419C,KLCE-2F 2M	1	
A2AMK1000A1E	777700000105	ROCKER S/W	SF-W101A-30BB	1	
Ass'y Main					
A2AMK1000A2E	BTEM00040470	T-FILTER	470PF 25V 6A	2	L15
A2AMK1000A2E	BTEM00040470	T-FILTER	470PF 25V 6A	2	L17
A2AMK1000A2E	CCMBF105Z0AJ	CAPACITOR CHIP/MONO	GRM42-6Y5V 105Z 25PE	8	C18
A2AMK1000A2E	CCMBF105Z0AJ	CAPACITOR CHIP/MONO	GRM42-6Y5V 105Z 25PE	8	C2
A2AMK1000A2E	CCMBF105Z0AJ	CAPACITOR CHIP/MONO	GRM42-6Y5V 105Z 25PE	8	C24
A2AMK1000A2E	CCMBF105Z0AJ	CAPACITOR CHIP/MONO	GRM42-6Y5V 105Z 25PE	8	C42
A2AMK1000A2E	CCMBF105Z0AJ	CAPACITOR CHIP/MONO	GRM42-6Y5V 105Z 25PE	8	C43
A2AMK1000A2E	CCMBF105Z0AJ	CAPACITOR CHIP/MONO	GRM42-6Y5V 105Z 25PE	8	C52
A2AMK1000A2E	CCMBF105Z0AJ	CAPACITOR CHIP/MONO	GRM42-6Y5V 105Z 25PE	8	C53
A2AMK1000A2E	CCMBF105Z0AJ	CAPACITOR CHIP/MONO	GRM42-6Y5V 105Z 25PE	8	C6
A2AMK1000A2E	CCMBJ103K0AH	CAPACITOR CHIP/MONO	GRM40 X7R 103 50PT	16	C1
A2AMK1000A2E	CCMBJ103K0AH	CAPACITOR CHIP/MONO	GRM40 X7R 103 50PT	16	C11
A2AMK1000A2E	CCMBJ103K0AH	CAPACITOR CHIP/MONO	GRM40 X7R 103 50PT	16	C12
A2AMK1000A2E	CCMBJ103K0AH	CAPACITOR CHIP/MONO	GRM40 X7R 103 50PT	16	C13
A2AMK1000A2E	CCMBJ103K0AH	CAPACITOR CHIP/MONO	GRM40 X7R 103 50PT	16	C4
A2AMK1000A2E	CCMBJ103K0AH	CAPACITOR CHIP/MONO	GRM40 X7R 103 50PT	16	C40
A2AMK1000A2E	CCMBJ103K0AH	CAPACITOR CHIP/MONO	GRM40 X7R 103 50PT	16	C41
A2AMK1000A2E	CCMBJ103K0AH	CAPACITOR CHIP/MONO	GRM40 X7R 103 50PT	16	C57
A2AMK1000A2E	CCMBJ103K0AH	CAPACITOR CHIP/MONO	GRM40 X7R 103 50PT	16	C58
A2AMK1000A2E	CCMBJ103K0AH	CAPACITOR CHIP/MONO	GRM40 X7R 103 50PT	16	C59
A2AMK1000A2E	CCMBJ103K0AH	CAPACITOR CHIP/MONO	GRM40 X7R 103 50PT	16	C60
A2AMK1000A2E	CCMBJ103K0AH	CAPACITOR CHIP/MONO	GRM40 X7R 103 50PT	16	C61
A2AMK1000A2E	CCMBJ103K0AH	CAPACITOR CHIP/MONO	GRM40 X7R 103 50PT	16	C62
A2AMK1000A2E	CCMBJ103K0AH	CAPACITOR CHIP/MONO	GRM40 X7R 103 50PT	16	C63
A2AMK1000A2E	CCMBJ103K0AH	CAPACITOR CHIP/MONO	GRM40 X7R 103 50PT	16	C64
A2AMK1000A2E	CCMBJ103K0AH	CAPACITOR CHIP/MONO	GRM40 X7R 103 50PT	16	C9
A2AMK1000A2E	CCMBJ104K0AH	CAPACITOR CHIP/MONO	GRM40 X7R 104K 50PE	4	C16
A2AMK1000A2E	CCMBJ104K0AH	CAPACITOR CHIP/MONO	GRM40 X7R 104K 50PE	4	C17
A2AMK1000A2E	CCMBJ104K0AH	CAPACITOR CHIP/MONO	GRM40 X7R 104K 50PE	4	C19
A2AMK1000A2E	CCMBJ104K0AH	CAPACITOR CHIP/MONO	GRM40 X7R 104K 50PE	4	C20
A2AMK1000A2E	CCMBJ220J0AH	CAPACITOR CHIP/MONO	GRM40 COG 220J 50PT	11	C14
A2AMK1000A2E	CCMBJ220J0AH	CAPACITOR CHIP/MONO	GRM40 COG 220J 50PT	11	C15
A2AMK1000A2E	CCMBJ220J0AH	CAPACITOR CHIP/MONO	GRM40 COG 220J 50PT	11	C3

ASS'Y CODE	PARTS CODE	DESCRIPTION	SPECIFICATION	Q'TY	Loc. No
A2AMK1000A2E	CCMBJ220J0AH	CAPACITOR CHIP/MONO	GRM40 COG 220J 50PT	11	C30
A2AMK1000A2E	CCMBJ220J0AH	CAPACITOR CHIP/MONO	GRM40 COG 220J 50PT	11	C31
A2AMK1000A2E	CCMBJ220J0AH	CAPACITOR CHIP/MONO	GRM40 COG 220J 50PT	11	C32
A2AMK1000A2E	CCMBJ220J0AH	CAPACITOR CHIP/MONO	GRM40 COG 220J 50PT	11	C33
A2AMK1000A2E	CCMBJ220J0AH	CAPACITOR CHIP/MONO	GRM40 COG 220J 50PT	11	C44
A2AMK1000A2E	CCMBJ220J0AH	CAPACITOR CHIP/MONO	GRM40 COG 220J 50PT	11	C45
A2AMK1000A2E	CCMBJ220J0AH	CAPACITOR CHIP/MONO	GRM40 COG 220J 50PT	11	C54
A2AMK1000A2E	CCMBJ220J0AH	CAPACITOR CHIP/MONO	GRM40 COG 220J 50PT	11	C55
A2AMK1000A2E	CCMBJ222J0AH	CAPACITOR CHIP/MONO	GRM40 X7R 222K 50PT	6	C46
A2AMK1000A2E	CCMBJ222J0AH	CAPACITOR CHIP/MONO	GRM40 X7R 222K 50PT	6	C47
A2AMK1000A2E	CCMBJ222J0AH	CAPACITOR CHIP/MONO	GRM40 X7R 222K 50PT	6	C48
A2AMK1000A2E	CCMBJ222J0AH	CAPACITOR CHIP/MONO	GRM40 X7R 222K 50PT	6	C49
A2AMK1000A2E	CCMBJ222J0AH	CAPACITOR CHIP/MONO	GRM40 X7R 222K 50PT	6	C5
A2AMK1000A2E	CCMBJ222J0AH	CAPACITOR CHIP/MONO	GRM40 X7R 222K 50PT	6	R52
A2AMK1000A2E	CCMBJ331J0AH	CAPACITOR CHIP/MONO	GRM40 COG 331J 50PT	4	C21
A2AMK1000A2E	CCMBJ331J0AH	CAPACITOR CHIP/MONO	GRM40 COG 331J 50PT	4	C23
A2AMK1000A2E	CCMBJ331J0AH	CAPACITOR CHIP/MONO	GRM40 COG 331J 50PT	4	C56
A2AMK1000A2E	CCMBJ331J0AH	CAPACITOR CHIP/MONO	GRM40 COG 331J 50PT	4	C84
A2AMK1000A2E	CCMBN101J0AJ	CAPACITOR CHIP/MONO	GRM40 COG 101J 100PT	4	C25
A2AMK1000A2E	CCMBN101J0AJ	CAPACITOR CHIP/MONO	GRM40 COG 101J 100PT	4	C26
A2AMK1000A2E	CCMBN101J0AJ	CAPACITOR CHIP/MONO	GRM40 COG 101J 100PT	4	C77
A2AMK1000A2E	CCMBN101J0AJ	CAPACITOR CHIP/MONO	GRM40 COG 101J 100PT	4	C78
A2AMK1000A2E	CCMBN102K0CG	CAPACITOR CHIP	1000pF 100V X7R 10%	1	C73
A2AMK1000A2E	CCMBN103K0CG	CAPACITOR CHIP	0.01uF 100V X7R	6	C35
A2AMK1000A2E	CCMBN103K0CG	CAPACITOR CHIP	0.01uF 100V X7R	6	C36
A2AMK1000A2E	CCMBN103K0CG	CAPACITOR CHIP	0.01uF 100V X7R	6	C74
A2AMK1000A2E	CCMBN103K0CG	CAPACITOR CHIP	0.01uF 100V X7R	6	C75
A2AMK1000A2E	CCMBN103K0CG	CAPACITOR CHIP	0.01uF 100V X7R	6	C81
A2AMK1000A2E	CCMBN103K0CG	CAPACITOR CHIP	0.01uF 100V X7R	6	C82
A2AMK1000A2E	CCMBN473K0CG	CAPACITOR CHIP	0.047uF 100V X7R 10%	4	C37
A2AMK1000A2E	CCMBN473K0CG	CAPACITOR CHIP	0.047uF 100V X7R 10%	4	C39
A2AMK1000A2E	CCMBN473K0CG	CAPACITOR CHIP	0.047uF 100V X7R 10%	4	C79
A2AMK1000A2E	CCMBN473K0CG	CAPACITOR CHIP	0.047uF 100V X7R 10%	4	C80
A2AMK1000A2E	CCMBR223K0AJ	CAPACITOR CHIP/MONO	GRM42-6 X7R 223K 200PE	5	C22
A2AMK1000A2E	CCMBR223K0AJ	CAPACITOR CHIP/MONO	GRM42-6 X7R 223K 200PE	5	C38
A2AMK1000A2E	CCMBR223K0AJ	CAPACITOR CHIP/MONO	GRM42-6 X7R 223K 200PE	5	C50
A2AMK1000A2E	CCMBR223K0AJ	CAPACITOR CHIP/MONO	GRM42-6 X7R 223K 200PE	5	C51
A2AMK1000A2E	CCMBR223K0AJ	CAPACITOR CHIP/MONO	GRM42-6 X7R 223K 200PE	5	C76
A2AMK1000A2E	CEEBE470MDX1	CAPACITOR E/ALUMINUM	47uF /16V (7SC1CAB476M)	5	C10
A2AMK1000A2E	CEEBE470MDX1	CAPACITOR E/ALUMINUM	47uF /16V (7SC1CAB476M)	5	C65
A2AMK1000A2E	CEEBE470MDX1	CAPACITOR E/ALUMINUM	47uF /16V (7SC1CAB476M)	5	C66
A2AMK1000A2E	CEEBE470MDX1	CAPACITOR E/ALUMINUM	47uF /16V (7SC1CAB476M)	5	C67
A2AMK1000A2E	CEEBE470MDX1	CAPACITOR E/ALUMINUM	47uF /16V (7SC1CAB476M)	5	C68
A2AMK1000A2E	CEETG471MHN4	CAPACITOR E/ALUMINUM	470uF/35v(1SG1VWM477M)	2	C69
A2AMK1000A2E	CEETG471MHN4	CAPACITOR E/ALUMINUM	470uF/35v(1SG1VWM477M)	2	C70
A2AMK1000A2E	CEETM222MPS1	CAPACITOR E/ALUMINUM	2200UF/80V(3HE1KVB228MHA)	3	C27
A2AMK1000A2E	CEETM222MPS1	CAPACITOR E/ALUMINUM	2200UF/80V(3HE1KVB228MHA)	3	C28
A2AMK1000A2E	CEETM222MPS1	CAPACITOR E/ALUMINUM	2200UF/80V(3HE1KVB228MHA)	3	C29
A2AMK1000A2E	CFMSJ684KKC0	MMK CAPACITOR	680NF 100V 10%	1	C34
A2AMK1000A2E	DDBP00010VX0	DUAL DIODE	BAV70(SMT)	4	D1
A2AMK1000A2E	DDBP00010VX0	DUAL DIODE	BAV70(SMT)	4	D2
A2AMK1000A2E	DDBP00010VX0	DUAL DIODE	BAV70(SMT)	4	D4
A2AMK1000A2E	DDBP00010VX0	DUAL DIODE	BAV70(SMT)	4	D5
A2AMK1000A2E	DD4B00350TB0	BRIDGE RECTIFER	DF01S(SMT)	1	BR2
A2AMK1000A2E	DPLT00821RR3	DOT-LED	LTL-1CHP RED R3.1	1	D3
A2AMK1000A2E	ICCM01530VX0	RETIG TIMER IC	MM74HC123AM	1	U16
A2AMK1000A2E	ICCM01540T20	AND GATE IC	74VHC08M	1	U5
A2AMK1000A2E	ICCM01550VX0	EX-OR GATE IC	74AC86SC	1	U6
A2AMK1000A2E	ICCM01560VX0	SCHMITT TRIGGER IC	74VHC132M	1	U4
A2AMK1000A2E	ICHY00390TS0	H-BRIDGE DROVER IC	HIP2100IB	2	U8
A2AMK1000A2E	ICHY00390TS0	H-BRIDGE DROVER IC	HIP2100IB	2	U9
A2AMK1000A2E	ICHY00410W70	EQUILOG MODULATOR	EQ 805	1	U11
A2AMK1000A2E	ICOP03200TC0	OP-AMP IC	MC33079DR2	1	U10
A2AMK1000A2E	ICOP03300T20	COMPARATOR IC	LM393MX	1	U1
A2AMK1000A2E	ICRG01070TC0	5V REGULATOR	MC78L05ACDR2	1	U13
A2AMK1000A2E	ICRG01080TC0	-5V REGULATOR	MC79L05ACD(SMD)	1	U15
A2AMK1000A2E	ICTT00430S70	INVERTER IC	N74F07AD	1	U7
A2AMK1000A2E	KIBK00310EHO	DUAL INDUCTOR	30uH 10A	1	L20

ASS'Y CODE	PARTS CODE	DESCRIPTION	SPECIFICATION	Q'TY	Loc. No
A2AMK1000A2E	KNCW009705T9	CONNECTOR-WAFER	JE202-1T-5P	1	ST1
A2AMK1000A2E	KORB00120C00	FERRIT BEAD	BL01RN1-A62-001	3	L1
A2AMK1000A2E	KORB00120C00	FERRIT BEAD	BL01RN1-A62-001	3	L2
A2AMK1000A2E	KORB00120C00	FERRIT BEAD	BL01RN1-A62-001	3	L5
A2AMK1000A2E	KORI00020000	AORCORE INDUCTOR	75nH	4	L3
A2AMK1000A2E	KORI00020000	AORCORE INDUCTOR	75nH	4	L4
A2AMK1000A2E	KORI00020000	AORCORE INDUCTOR	75nH	4	L6
A2AMK1000A2E	KORI00020000	AORCORE INDUCTOR	75nH	4	L7
A2AMK1000A2E	PCSA053101KB	PCB-(EPOXY 4 LAYER)	A1A-531,FR2(100x100x1.6t)	1	
A2AMK1000A2E	RCPBBX009520	CHIP RESISTOR(SMT)	681 50PPM 0.1% (MMA0204)	2	R36
A2AMK1000A2E	RCPBBX009520	CHIP RESISTOR(SMT)	681 50PPM 0.1% (MMA0204)	2	R38
A2AMK1000A2E	RCPBBX010Z22	RESISTOR-CHIP C/FILM	33.2k 1/10W 1% B	2	R3
A2AMK1000A2E	RCPBBX010Z22	RESISTOR-CHIP C/FILM	33.2k 1/10W 1% B	2	R53
A2AMK1000A2E	RCPBB000J21C	RESISTOR-CHIP C/FILM	0ohm 1/10W 5% B	3	R76
A2AMK1000A2E	RCPBB000J21C	RESISTOR-CHIP C/FILM	0ohm 1/10W 5% B	3	R80
A2AMK1000A2E	RCPBB000J21C	RESISTOR-CHIP C/FILM	0ohm 1/10W 5% B	3	R82
A2AMK1000A2E	RCPBB102F21C	RESISTOR-CHIP C/FILM	1Kohm 1% CHIP	1	R54
A2AMK1000A2E	RCPBB103F21C	RESISTOR-CHIP C/FILM	10Kohm 1/10W 1% B	6	R1
A2AMK1000A2E	RCPBB103F21C	RESISTOR-CHIP C/FILM	10Kohm 1/10W 1% B	6	R11
A2AMK1000A2E	RCPBB103F21C	RESISTOR-CHIP C/FILM	10Kohm 1/10W 1% B	6	R16
A2AMK1000A2E	RCPBB103F21C	RESISTOR-CHIP C/FILM	10Kohm 1/10W 1% B	6	R6
A2AMK1000A2E	RCPBB103F21C	RESISTOR-CHIP C/FILM	10Kohm 1/10W 1% B	6	R61
A2AMK1000A2E	RCPBB103F21C	RESISTOR-CHIP C/FILM	10Kohm 1/10W 1% B	6	R8
A2AMK1000A2E	RCPBB104F21C	RESISTOR-CHIP C/FILM	100K 1/10W 1% B	5	R39
A2AMK1000A2E	RCPBB104F21C	RESISTOR-CHIP C/FILM	100K 1/10W 1% B	5	R40
A2AMK1000A2E	RCPBB104F21C	RESISTOR-CHIP C/FILM	100K 1/10W 1% B	5	R5
A2AMK1000A2E	RCPBB104F21C	RESISTOR-CHIP C/FILM	100K 1/10W 1% B	5	R58
A2AMK1000A2E	RCPBB104F21C	RESISTOR-CHIP C/FILM	100K 1/10W 1% B	5	R78
A2AMK1000A2E	RCPBB105J21C	RESISTOR-CHIP C/FILM	1Mohm 1/10W 5% B	1	R4
A2AMK1000A2E	RCPBB150F21C	RESISTOR-CHIP C/FILM	15ohm 1/10W 1% B	4	R22
A2AMK1000A2E	RCPBB150F21C	RESISTOR-CHIP C/FILM	15ohm 1/10W 1% B	4	R23
A2AMK1000A2E	RCPBB150F21C	RESISTOR-CHIP C/FILM	15ohm 1/10W 1% B	4	R24
A2AMK1000A2E	RCPBB150F21C	RESISTOR-CHIP C/FILM	15ohm 1/10W 1% B	4	R25
A2AMK1000A2E	RCPBB151F21C	RESISTOR-CHIP C/FILM	150ohm 1% CHIP	1	R74
A2AMK1000A2E	RCPBB182F21C	RESISTOR-CHIP C/FILM	1.8K 1% 1/10W chip	1	R70
A2AMK1000A2E	RCPBB203F21C	RESISTOR-CHIP C/FILM	20Kohm 1/10W 1% B	2	R12
A2AMK1000A2E	RCPBB203F21C	RESISTOR-CHIP C/FILM	20Kohm 1/10W 1% B	2	R69
A2AMK1000A2E	RCPBB221F21C	RESISTOR-CHIP C/FILM	220R 1% 1/10W chip	4	R43
A2AMK1000A2E	RCPBB221F21C	RESISTOR-CHIP C/FILM	220R 1% 1/10W chip	4	R44
A2AMK1000A2E	RCPBB221F21C	RESISTOR-CHIP C/FILM	220R 1% 1/10W chip	4	R45
A2AMK1000A2E	RCPBB221F21C	RESISTOR-CHIP C/FILM	220R 1% 1/10W chip	4	R46
A2AMK1000A2E	RCPBB224J21C	RESISTOR-CHIP C/FILM	220Kohm 1/10W 5% B	1	R2
A2AMK1000A2E	RCPBB242F21C	RESISTOR-CHIP C/FILM	2.4Kohm 1/10W 1% B	2	R20
A2AMK1000A2E	RCPBB242F21C	RESISTOR-CHIP C/FILM	2.4Kohm 1/10W 1% B	2	R21
A2AMK1000A2E	RCPBB283F21C	RESISTOR-CHIP C/FILM	28Kohm 1/10W 1% B	1	R34
A2AMK1000A2E	RCPBB331F21C	RESISTOR-CHIP C/FILM	330R 1% 1/10W chip	2	R48
A2AMK1000A2E	RCPBB331F21C	RESISTOR-CHIP C/FILM	330R 1% 1/10W chip	2	R50
A2AMK1000A2E	RCPBB332F21C	RESISTOR-CHIP C/FILM	3.3K 1/10W 1% B	1	R7
A2AMK1000A2E	RCPBB472F21C	RESISTOR-CHIP C/FILM	4.7K 1% 1/10W chip	9	R10
A2AMK1000A2E	RCPBB472F21C	RESISTOR-CHIP C/FILM	4.7K 1% 1/10W chip	9	R17
A2AMK1000A2E	RCPBB472F21C	RESISTOR-CHIP C/FILM	4.7K 1% 1/10W chip	9	R41
A2AMK1000A2E	RCPBB472F21C	RESISTOR-CHIP C/FILM	4.7K 1% 1/10W chip	9	R42
A2AMK1000A2E	RCPBB472F21C	RESISTOR-CHIP C/FILM	4.7K 1% 1/10W chip	9	R56
A2AMK1000A2E	RCPBB472F21C	RESISTOR-CHIP C/FILM	4.7K 1% 1/10W chip	9	R57
A2AMK1000A2E	RCPBB472F21C	RESISTOR-CHIP C/FILM	4.7K 1% 1/10W chip	9	R59
A2AMK1000A2E	RCPBB472F21C	RESISTOR-CHIP C/FILM	4.7K 1% 1/10W chip	9	R60
A2AMK1000A2E	RCPBB472F21C	RESISTOR-CHIP C/FILM	4.7K 1% 1/10W chip	9	R9
A2AMK1000A2E	RCPBB560F21C	RESISTOR-CHIP C/FILM	56R 1% 1/10W chip	2	R15
A2AMK1000A2E	RCPBB560F21C	RESISTOR-CHIP C/FILM	56R 1% 1/10W chip	2	R34
A2AMK1000A2E	RCPBF103F520	CHIP RESISTOR(SMT)	10K 50ppm 0.1% (MMA0204)	2	R35
A2AMK1000A2E	RCPBF103F520	CHIP RESISTOR(SMT)	10K 50ppm 0.1% (MMA0204)	2	R37
A2AMK1000A2E	RCPBF120F520	CHIP RESISTOR(SMT)	12R 50ppm 1%(SSM0204 MELF)	2	R26
A2AMK1000A2E	RCPBF120F520	CHIP RESISTOR(SMT)	12R 50ppm 1%(SSM0204 MELF)	2	R27
A2AMK1000A2E	RCPBF3R0F520	CHIP RESISTOR(SMT)	3R 50ppm 1%(SSM0204 MELF)	6	R28
A2AMK1000A2E	RCPBF3R0F520	CHIP RESISTOR(SMT)	3R 50ppm 1%(SSM0204 MELF)	6	R29
A2AMK1000A2E	RCPBF3R0F520	CHIP RESISTOR(SMT)	3R 50ppm 1%(SSM0204 MELF)	6	R64
A2AMK1000A2E	RCPBF3R0F520	CHIP RESISTOR(SMT)	3R 50ppm 1%(SSM0204 MELF)	6	R65
A2AMK1000A2E	RCPBF3R0F520	CHIP RESISTOR(SMT)	3R 50ppm 1%(SSM0204 MELF)	6	R66

ASS'Y CODE	PARTS CODE	DESCRIPTION	SPECIFICATION	Q'TY	Loc. No
A2AMK1000A2E	RCPBF3R0F520	CHIP RESISTOR(SMT)	3R 50ppm 1%(SSM0204 MELF)	6	R67
A2AMK1000A2E	RCPBF682F520	CHIP RESISTOR(SMT)	6K8 50ppm 1%(SSM0204 MELF)	2	R47
A2AMK1000A2E	RCPBF682F520	CHIP RESISTOR(SMT)	6K8 50ppm 1%(SSM0204 MELF)	2	R49
A2AMK1000A2E	RCPBH1R0F620	CHIP RESISTOR(SMT)	1R0 50ppm 1%(SSM0207 MELF)	4	R30
A2AMK1000A2E	RCPBH1R0F620	CHIP RESISTOR(SMT)	1R0 50ppm 1%(SSM0207 MELF)	4	R31
A2AMK1000A2E	RCPBH1R0F620	CHIP RESISTOR(SMT)	1R0 50ppm 1%(SSM0207 MELF)	4	R32
A2AMK1000A2E	RCPBH1R0F620	CHIP RESISTOR(SMT)	1R0 50ppm 1%(SSM0207 MELF)	4	R33
A2AMK1000A2E	TRBA01770TC0	TR	MMBT2222ALT1(SMT)	4	Q3
A2AMK1000A2E	TRBA01770TC0	TR	MMBT2222ALT1(SMT)	4	Q5
A2AMK1000A2E	TRBA01770TC0	TR	MMBT2222ALT1(SMT)	4	Q7
A2AMK1000A2E	TRBA01770TC0	TR	MMBT2222ALT1(SMT)	4	Q9
A2AMK1000A2E	TRBC01950TC0	TRANSISTOR	MMBT2907ALT1(SMT)	4	Q10
A2AMK1000A2E	TRBC01950TC0	TRANSISTOR	MMBT2907ALT1(SMT)	4	Q4
A2AMK1000A2E	TRBC01950TC0	TRANSISTOR	MMBT2907ALT1(SMT)	4	Q6
A2AMK1000A2E	TRBC01950TC0	TRANSISTOR	MMBT2907ALT1(SMT)	4	Q8
A2AMK1000A2E	TRSK00270W20	MOSFER(100V)	IRF1540N	4	Q11
A2AMK1000A2E	TRSK00270W20	MOSFER(100V)	IRF1540N	4	Q12
A2AMK1000A2E	TRSK00270W20	MOSFER(100V)	IRF1540N	4	Q14
A2AMK1000A2E	TRSK00270W20	MOSFER(100V)	IRF1540N	4	Q15
A2AMK1000A2E	KNCW0201008T	WAFER	LW0640-08	1	ST2
A2AMK1000A2E	KNCW0202001T	WAFER	35718-4410	1	J2
A2AMK1000A2E	KNCW0203001T	WAFER	35725-4410	1	J1
Ass'y Front					
A2AMK1000A3E	CCATF103ZAAF	CAPACITOR CERAMIC	0.01uF Z 25V F T	4	C103
A2AMK1000A3E	CCATF103ZAAF	CAPACITOR CERAMIC	0.01uF Z 25V F T	4	C105
A2AMK1000A3E	CCATF103ZAAF	CAPACITOR CERAMIC	0.01uF Z 25V F T	4	C25
A2AMK1000A3E	CCATF103ZAAF	CAPACITOR CERAMIC	0.01uF Z 25V F T	4	C30
A2AMK1000A3E	CCATJ102KAAB	CAPACITOR CERAMIC	1000PF K 50V B T	14	C10
A2AMK1000A3E	CCATJ102KAAB	CAPACITOR CERAMIC	1000PF K 50V B T	14	C15
A2AMK1000A3E	CCATJ102KAAB	CAPACITOR CERAMIC	1000PF K 50V B T	14	C16
A2AMK1000A3E	CCATJ102KAAB	CAPACITOR CERAMIC	1000PF K 50V B T	14	C17
A2AMK1000A3E	CCATJ102KAAB	CAPACITOR CERAMIC	1000PF K 50V B T	14	C20
A2AMK1000A3E	CCATJ102KAAB	CAPACITOR CERAMIC	1000PF K 50V B T	14	C22
A2AMK1000A3E	CCATJ102KAAB	CAPACITOR CERAMIC	1000PF K 50V B T	14	C26
A2AMK1000A3E	CCATJ102KAAB	CAPACITOR CERAMIC	1000PF K 50V B T	14	C31
A2AMK1000A3E	CCATJ102KAAB	CAPACITOR CERAMIC	1000PF K 50V B T	14	C32
A2AMK1000A3E	CCATJ102KAAB	CAPACITOR CERAMIC	1000PF K 50V B T	14	C33
A2AMK1000A3E	CCATJ102KAAB	CAPACITOR CERAMIC	1000PF K 50V B T	14	C34
A2AMK1000A3E	CCATJ102KAAB	CAPACITOR CERAMIC	1000PF K 50V B T	14	C4
A2AMK1000A3E	CCATJ102KAAB	CAPACITOR CERAMIC	1000PF K 50V B T	14	C5
A2AMK1000A3E	CCATJ102KAAB	CAPACITOR CERAMIC	1000PF K 50V B T	14	C8
A2AMK1000A3E	CCATJ104ZAAF	CAPACITOR CERAMIC	0.1uF Z 50V F T	2	C115
A2AMK1000A3E	CCATJ104ZAAF	CAPACITOR CERAMIC	0.1uF Z 50V F T	2	C116
A2AMK1000A3E	CCATJ220JAAZ	CAPACITOR CERAMIC	22PF J 50V SL T	1	C35
A2AMK1000A3E	CCATJ330JAAZ	CAPACITOR CERAMIC	33PF J 50V SL T	2	C1
A2AMK1000A3E	CCATJ330JAAZ	CAPACITOR CERAMIC	33PF J 50V SL T	2	C29
A2AMK1000A3E	CEETE101MDI0	CAPACITOR E/ALUMINUM	100uF M 16V 6.3x11 T	1	C118
A2AMK1000A3E	CEETF220MCIO	CAPACITOR E/ALUMINUM	22uF M 25V 5x11 T	1	C101
A2AMK1000A3E	CEETF470MCIO	CAPACITOR E/ALUMINUM	47uF M 25V 5x11 T	4	C102
A2AMK1000A3E	CEETF470MCIO	CAPACITOR E/ALUMINUM	47uF M 25V 5x11 T	4	C104
A2AMK1000A3E	CEETF470MCIO	CAPACITOR E/ALUMINUM	47uF M 25V 5x11 T	4	C106
A2AMK1000A3E	CEETF470MCIO	CAPACITOR E/ALUMINUM	47uF M 25V 5x11 T	4	C107
A2AMK1000A3E	CEETJ1R0MCIO	CAPACITOR E/ALUMINUM	1.0uF M 50V 5x11 T	1	C108
A2AMK1000A3E	CEETJ100MCIO	CAPACITOR E/ALUMINUM	10uF M 50V 5x11 T	7	C117
A2AMK1000A3E	CEETJ100MCIO	CAPACITOR E/ALUMINUM	10uF M 50V 5x11 T	7	C18
A2AMK1000A3E	CEETJ100MCIO	CAPACITOR E/ALUMINUM	10uF M 50V 5x11 T	7	C19
A2AMK1000A3E	CEETJ100MCIO	CAPACITOR E/ALUMINUM	10uF M 50V 5x11 T	7	C24
A2AMK1000A3E	CEETJ100MCIO	CAPACITOR E/ALUMINUM	10uF M 50V 5x11 T	7	C6
A2AMK1000A3E	CEETJ100MCIO	CAPACITOR E/ALUMINUM	10uF M 50V 5x11 T	7	C7
A2AMK1000A3E	CEETJ100MCIO	CAPACITOR E/ALUMINUM	10uF M 50V 5x11 T	7	C9
A2AMK1000A3E	CFMTJ474JDF0	CAPACITOR F/POLYESTR	0.47uF J 50V 6x8 TL	3	C201
A2AMK1000A3E	CFMTJ474JDF0	CAPACITOR F/POLYESTR	0.47uF J 50V 6x8 TL	3	C27
A2AMK1000A3E	CFMTJ474JDF0	CAPACITOR F/POLYESTR	0.47uF J 50V 6x8 TL	3	C28
A2AMK1000A3E	CFMTL224JEF0	CAPACITOR F/POLYESTR	0.22uF J 63V 7.5x8.5 TL	2	C12
A2AMK1000A3E	CFMTL224JEF0	CAPACITOR F/POLYESTR	0.22uF J 63V 7.5x8.5 TL	2	C14
A2AMK1000A3E	CFMTL684JFIO	CAPACITOR F/POLYESTR	0.68uF J 63V 8x11.5 TL	2	C2
A2AMK1000A3E	CFMTL684JFIO	CAPACITOR F/POLYESTR	0.68uF J 63V 8x11.5 TL	2	C3
A2AMK1000A3E	CFMTN154JHH0	CAPACITOR F/POLYESTR	0.15uF J 100V 10.3x9.8 T	1	C23

ASS'Y CODE	PARTS CODE	DESCRIPTION	SPECIFICATION	Q'TY	Loc. No
A2AMK1000A3E	CFMTN223JEK0	CAPACITOR F/POLYESTR	0.022uF J 100V 7.4x13 T	2	C11
A2AMK1000A3E	CFMTN223JEK0	CAPACITOR F/POLYESTR	0.022uF J 100V 7.4x13 T	2	C13
A2AMK1000A3E	CFTTJ104JEC0	CAPACITOR F/TF	0.1uF J 50V ECQ-V1H104JL3	1	C21
A2AMK1000A3E	DDTS00070SO0	DIODE-SI	1SS133 (40V 0.11A) DO-40 T	9	D1
A2AMK1000A3E	DDTS00070SO0	DIODE-SI	1SS133 (40V 0.11A) DO-40 T	9	D2
A2AMK1000A3E	DDTS00070SO0	DIODE-SI	1SS133 (40V 0.11A) DO-40 T	9	D201
A2AMK1000A3E	DDTS00070SO0	DIODE-SI	1SS133 (40V 0.11A) DO-40 T	9	D202
A2AMK1000A3E	DDTS00070SO0	DIODE-SI	1SS133 (40V 0.11A) DO-40 T	9	D203
A2AMK1000A3E	DDTS00070SO0	DIODE-SI	1SS133 (40V 0.11A) DO-40 T	9	D204
A2AMK1000A3E	DDTS00070SO0	DIODE-SI	1SS133 (40V 0.11A) DO-40 T	9	D205
A2AMK1000A3E	DDTS00070SO0	DIODE-SI	1SS133 (40V 0.11A) DO-40 T	9	D206
A2AMK1000A3E	DDTS00070SO0	DIODE-SI	1SS133 (40V 0.11A) DO-40 T	9	D3
A2AMK1000A3E	DPLT00840MG3	DOT-LED	LTL-1CHG GRN R3.1	1	LD1
A2AMK1000A3E	ICOP03310TV0	IC OP AMP	TL074ACD	2	U1
A2AMK1000A3E	ICOP03310TV0	IC OP AMP	TL074ACD	2	U2
A2AMK1000A3E	KNCW002402T9	CONNECTOR-WAFER	53014-02 2.0mm WHT	1	CH104
A2AMK1000A3E	KNCW009902T9	CONNECTOR-WAFER	JE202A-1T-02	2	CN101
A2AMK1000A3E	KNCW009902T9	CONNECTOR-WAFER	JE202A-1T-02	2	CN102
A2AMK1000A3E	MPAC11620004	FUSE CLIP	5.2Pi TAPPING TYPE	2	FC101
A2AMK1000A3E	MPAC11620004	FUSE CLIP	5.2Pi TAPPING TYPE	2	FC102
A2AMK1000A3E	MRAG13710004	SUPPORT-LED	RUBBER 12.7m/m	1	
A2AMK1000A3E	PCSA0532011B	PCB	A1A-532,FR1(247x247x1.6t)	1	PCB1
A2AMK1000A3E	RCFTE102J000	RESISTOR-CARBON FILM	1Kohm 1/5W 5% T	1	R202
A2AMK1000A3E	RCFTE103J000	RESISTOR-CARBON FILM	10Kohm 1/5W 5% T	5	R110
A2AMK1000A3E	RCFTE103J000	RESISTOR-CARBON FILM	10Kohm 1/5W 5% T	5	R114
A2AMK1000A3E	RCFTE103J000	RESISTOR-CARBON FILM	10Kohm 1/5W 5% T	5	R15
A2AMK1000A3E	RCFTE103J000	RESISTOR-CARBON FILM	10Kohm 1/5W 5% T	5	R18
A2AMK1000A3E	RCFTE103J000	RESISTOR-CARBON FILM	10Kohm 1/5W 5% T	5	R20
A2AMK1000A3E	RCFTE222J000	RESISTOR-CARBON FILM	2.2Kohm 1/5W 5% T	1	R107
A2AMK1000A3E	RCFTE223J000	RESISTOR-CARBON FILM	22Kohm 1/5W 5% T	2	R26
A2AMK1000A3E	RCFTE223J000	RESISTOR-CARBON FILM	22Kohm 1/5W 5% T	2	R33
A2AMK1000A3E	RCFTE271J000	RESISTOR-CARBON FILM	270ohm 1/5W 5% T	1	R201
A2AMK1000A3E	RCFTE272J000	RESISTOR-CARBON FILM	2.7Kohm 1/5W 5% T	3	R11
A2AMK1000A3E	RCFTE272J000	RESISTOR-CARBON FILM	2.7Kohm 1/5W 5% T	3	R6
A2AMK1000A3E	RCFTE272J000	RESISTOR-CARBON FILM	2.7Kohm 1/5W 5% T	3	R7
A2AMK1000A3E	RCFTE273J000	RESISTOR-CARBON FILM	27Kohm 1/5W 5% T	2	R25
A2AMK1000A3E	RCFTE273J000	RESISTOR-CARBON FILM	27Kohm 1/5W 5% T	2	R5
A2AMK1000A3E	RCFTE393J000	RESISTOR-CARBON FILM	39Kohm 1/5W 5% T	1	R30
A2AMK1000A3E	RCFTE433J000	RESISTOR-CARBON FILM	43Kohm 1/5W 5% T	1	R24
A2AMK1000A3E	RCFTE470J000	RESISTOR-CARBON FILM	47ohm 1/5W 5% T	4	R102
A2AMK1000A3E	RCFTE470J000	RESISTOR-CARBON FILM	47ohm 1/5W 5% T	4	R103
A2AMK1000A3E	RCFTE470J000	RESISTOR-CARBON FILM	47ohm 1/5W 5% T	4	R104
A2AMK1000A3E	RCFTE470J000	RESISTOR-CARBON FILM	47ohm 1/5W 5% T	4	R105
A2AMK1000A3E	RCFTE472J000	RESISTOR-CARBON FILM	4.7Kohm 1/5W 5% T	5	R106
A2AMK1000A3E	RCFTE472J000	RESISTOR-CARBON FILM	4.7Kohm 1/5W 5% T	5	R108
A2AMK1000A3E	RCFTE472J000	RESISTOR-CARBON FILM	4.7Kohm 1/5W 5% T	5	R109
A2AMK1000A3E	RCFTE472J000	RESISTOR-CARBON FILM	4.7Kohm 1/5W 5% T	5	R34
A2AMK1000A3E	RCFTE472J000	RESISTOR-CARBON FILM	4.7Kohm 1/5W 5% T	5	R35
A2AMK1000A3E	RCFTE473J000	RESISTOR-CARBON FILM	47Kohm 1/5W 5% T	7	R111
A2AMK1000A3E	RCFTE473J000	RESISTOR-CARBON FILM	47Kohm 1/5W 5% T	7	R17
A2AMK1000A3E	RCFTE473J000	RESISTOR-CARBON FILM	47Kohm 1/5W 5% T	7	R22
A2AMK1000A3E	RCFTE473J000	RESISTOR-CARBON FILM	47Kohm 1/5W 5% T	7	R28
A2AMK1000A3E	RCFTE473J000	RESISTOR-CARBON FILM	47Kohm 1/5W 5% T	7	R29
A2AMK1000A3E	RCFTE473J000	RESISTOR-CARBON FILM	47Kohm 1/5W 5% T	7	R3
A2AMK1000A3E	RCFTE473J000	RESISTOR-CARBON FILM	47Kohm 1/5W 5% T	7	R4
A2AMK1000A3E	RCFTE474J000	RESISTOR-CARBON FILM	470Kohm 1/5W 5% T	4	R12
A2AMK1000A3E	RCFTE474J000	RESISTOR-CARBON FILM	470Kohm 1/5W 5% T	4	R16
A2AMK1000A3E	RCFTE474J000	RESISTOR-CARBON FILM	470Kohm 1/5W 5% T	4	R19
A2AMK1000A3E	RCFTE474J000	RESISTOR-CARBON FILM	470Kohm 1/5W 5% T	4	R21
A2AMK1000A3E	RCFTE513J000	RESISTOR-CARBON FILM	51Kohm 1/5W 5% T	1	R27
A2AMK1000A3E	RCFTE562J000	RESISTOR-CARBON FILM	5.6Kohm 1/5W 5% T	4	R10
A2AMK1000A3E	RCFTE562J000	RESISTOR-CARBON FILM	5.6Kohm 1/5W 5% T	4	R112
A2AMK1000A3E	RCFTE562J000	RESISTOR-CARBON FILM	5.6Kohm 1/5W 5% T	4	R113
A2AMK1000A3E	RCFTE562J000	RESISTOR-CARBON FILM	5.6Kohm 1/5W 5% T	4	R23
A2AMK1000A3E	RCFTE563J000	RESISTOR-CARBON FILM	56Kohm 1/5W 5% T	1	R31
A2AMK1000A3E	RCFTE683J000	RESISTOR-CARBON FILM	68Kohm 1/5W 5% T	3	R1
A2AMK1000A3E	RCFTE683J000	RESISTOR-CARBON FILM	68Kohm 1/5W 5% T	3	R14
A2AMK1000A3E	RCFTE683J000	RESISTOR-CARBON FILM	68Kohm 1/5W 5% T	3	R9

ASS'Y CODE	PARTS CODE	DESCRIPTION	SPECIFICATION	Q'TY	Loc. No
A2AMK1000A3E	RJWT0000AAA0	RESISTOR-JUMPER WIRE	60mm-TX123 F	35	JW1
A2AMK1000A3E	RJWT0000AAA0	RESISTOR-JUMPER WIRE	60mm-TX123 F	35	JW14
A2AMK1000A3E	RJWT0000AAA0	RESISTOR-JUMPER WIRE	60mm-TX123 F	35	JW15
A2AMK1000A3E	RJWT0000AAA0	RESISTOR-JUMPER WIRE	60mm-TX123 F	35	JW16
A2AMK1000A3E	RJWT0000AAA0	RESISTOR-JUMPER WIRE	60mm-TX123 F	35	JW17
A2AMK1000A3E	RJWT0000AAA0	RESISTOR-JUMPER WIRE	60mm-TX123 F	35	JW18
A2AMK1000A3E	RJWT0000AAA0	RESISTOR-JUMPER WIRE	60mm-TX123 F	35	JW19
A2AMK1000A3E	RJWT0000AAA0	RESISTOR-JUMPER WIRE	60mm-TX123 F	35	JW2
A2AMK1000A3E	RJWT0000AAA0	RESISTOR-JUMPER WIRE	60mm-TX123 F	35	JW20
A2AMK1000A3E	RJWT0000AAA0	RESISTOR-JUMPER WIRE	60mm-TX123 F	35	JW21
A2AMK1000A3E	RJWT0000AAA0	RESISTOR-JUMPER WIRE	60mm-TX123 F	35	JW22
A2AMK1000A3E	RJWT0000AAA0	RESISTOR-JUMPER WIRE	60mm-TX123 F	35	JW23
A2AMK1000A3E	RJWT0000AAA0	RESISTOR-JUMPER WIRE	60mm-TX123 F	35	JW24
A2AMK1000A3E	RJWT0000AAA0	RESISTOR-JUMPER WIRE	60mm-TX123 F	35	JW25
A2AMK1000A3E	RJWT0000AAA0	RESISTOR-JUMPER WIRE	60mm-TX123 F	35	JW26
A2AMK1000A3E	RJWT0000AAA0	RESISTOR-JUMPER WIRE	60mm-TX123 F	35	JW27
A2AMK1000A3E	RJWT0000AAA0	RESISTOR-JUMPER WIRE	60mm-TX123 F	35	JW28
A2AMK1000A3E	RJWT0000AAA0	RESISTOR-JUMPER WIRE	60mm-TX123 F	35	JW29
A2AMK1000A3E	RJWT0000AAA0	RESISTOR-JUMPER WIRE	60mm-TX123 F	35	JW30
A2AMK1000A3E	RJWT0000AAA0	RESISTOR-JUMPER WIRE	60mm-TX123 F	35	JW31
A2AMK1000A3E	RJWT0000AAA0	RESISTOR-JUMPER WIRE	60mm-TX123 F	35	JW32
A2AMK1000A3E	RJWT0000AAA0	RESISTOR-JUMPER WIRE	60mm-TX123 F	35	JW33
A2AMK1000A3E	RJWT0000AAA0	RESISTOR-JUMPER WIRE	60mm-TX123 F	35	JW34
A2AMK1000A3E	RJWT0000AAA0	RESISTOR-JUMPER WIRE	60mm-TX123 F	35	JW35
A2AMK1000A3E	RJWT0000AAA0	RESISTOR-JUMPER WIRE	60mm-TX123 F	35	JW36
A2AMK1000A3E	RJWT0000AAA0	RESISTOR-JUMPER WIRE	60mm-TX123 F	35	JW37
A2AMK1000A3E	RJWT0000AAA0	RESISTOR-JUMPER WIRE	60mm-TX123 F	35	JW38
A2AMK1000A3E	RJWT0000AAA0	RESISTOR-JUMPER WIRE	60mm-TX123 F	35	JW39
A2AMK1000A3E	RJWT0000AAA0	RESISTOR-JUMPER WIRE	60mm-TX123 F	35	JW4
A2AMK1000A3E	RJWT0000AAA0	RESISTOR-JUMPER WIRE	60mm-TX123 F	35	JW40
A2AMK1000A3E	RJWT0000AAA0	RESISTOR-JUMPER WIRE	60mm-TX123 F	35	JW5
A2AMK1000A3E	RJWT0000AAA0	RESISTOR-JUMPER WIRE	60mm-TX123 F	35	JW6
A2AMK1000A3E	RJWT0000AAA0	RESISTOR-JUMPER WIRE	60mm-TX123 F	35	JW7
A2AMK1000A3E	RJWT0000AAA0	RESISTOR-JUMPER WIRE	60mm-TX123 F	35	JW8
A2AMK1000A3E	RJWT0000AAA0	RESISTOR-JUMPER WIRE	60mm-TX123 F	35	JW9
A2AMK1000A3E	SKAO0220C50	AC POWER SOCKET	HJC-028	1	AC101
A2AMK1000A3E	SKRC00400041	SOCKET-RCA	JK0400450N	1	J1
A2AMK1000A3E	SWSL01000098	SLIDE SWITCH	SSAF122NB	1	SW102
A2AMK1000A3E	TESP0046008S	TERMINAL SPEAKER	SH0810361P 8P	1	J2
A2AMK1000A3E	TRTA0008YSD0	TRANSISTOR P-H FREQ	KTA1266-Y TO92	1	Q106
A2AMK1000A3E	TRTA00940SD0	TRANSISTOR P-H FREQ	KRA107M W/RESIST TO92M	3	Q101
A2AMK1000A3E	TRTA00940SD0	TRANSISTOR P-H FREQ	KRA107M W/RESIST TO92M	3	Q104
A2AMK1000A3E	TRTA00940SD0	TRANSISTOR P-H FREQ	KRA107M W/RESIST TO92M	3	Q105
A2AMK1000A3E	TRTD00200SD0	TRANSISTOR N-L FREQ	KTD-1302 TO92	2	Q102
A2AMK1000A3E	TRTD00200SD0	TRANSISTOR N-L FREQ	KTD-1302 TO92	2	Q103
A2AMK1000A3E	U20811713250	WIRE-ASS'Y	UL1007#26 BRN-130	1	
A2AMK1000A3E	U3629B312480	WIRE-ASS'Y	UL1618#18 WHT 120 3P	1	
A2AMK1000A3E	U82971613200	WIRE-ASS'Y	UL1007#24 VIT-130	1	
A2AMK1000A3E	CACSS472M200	CAPACITOR AC	KH DE1310E 472M 250V P10mm	1	C114
A2AMK1000A3E	VRDED024B103	V/R RK09 10KB*4	RK0971410-10KBx4	1	VR101
A2AMK1000A3E	VRDED025A503	V/R RK09 50KA	RK0971110-50KA	2	VR201
A2AMK1000A3E	VRDED025A503	V/R RK09 50KA	RK0971110-50KA	2	VR301
Ass'y Sub					
A2AMK1000AZE	ZBNG007004ZL	BOND-ADHESIVE	#575	0.5	
A2AMK1000AZE	ZSBR00010060	SOLDER-BAR	SN60	15	
A2AMK1000AZE	ZSWR00010F60	SOLDER-WIRE	D1.0 SN60	15	#
A2AMK1000AZE	ZZFX00010000	FLUX	ROSIN 28	7	#
A2AMK1000AZE	ZZTH00010000	DILUENT	ROSIN	2	
A2AMK1000AZE	ZBNG004000ZL	BOND-ADHESIVE	SC-306	0.5	

NO	DATE	POS.	CONTENTS	NO	DATE	POS.	CONTENTS

BLOCK DIAGRAM: AMP 250

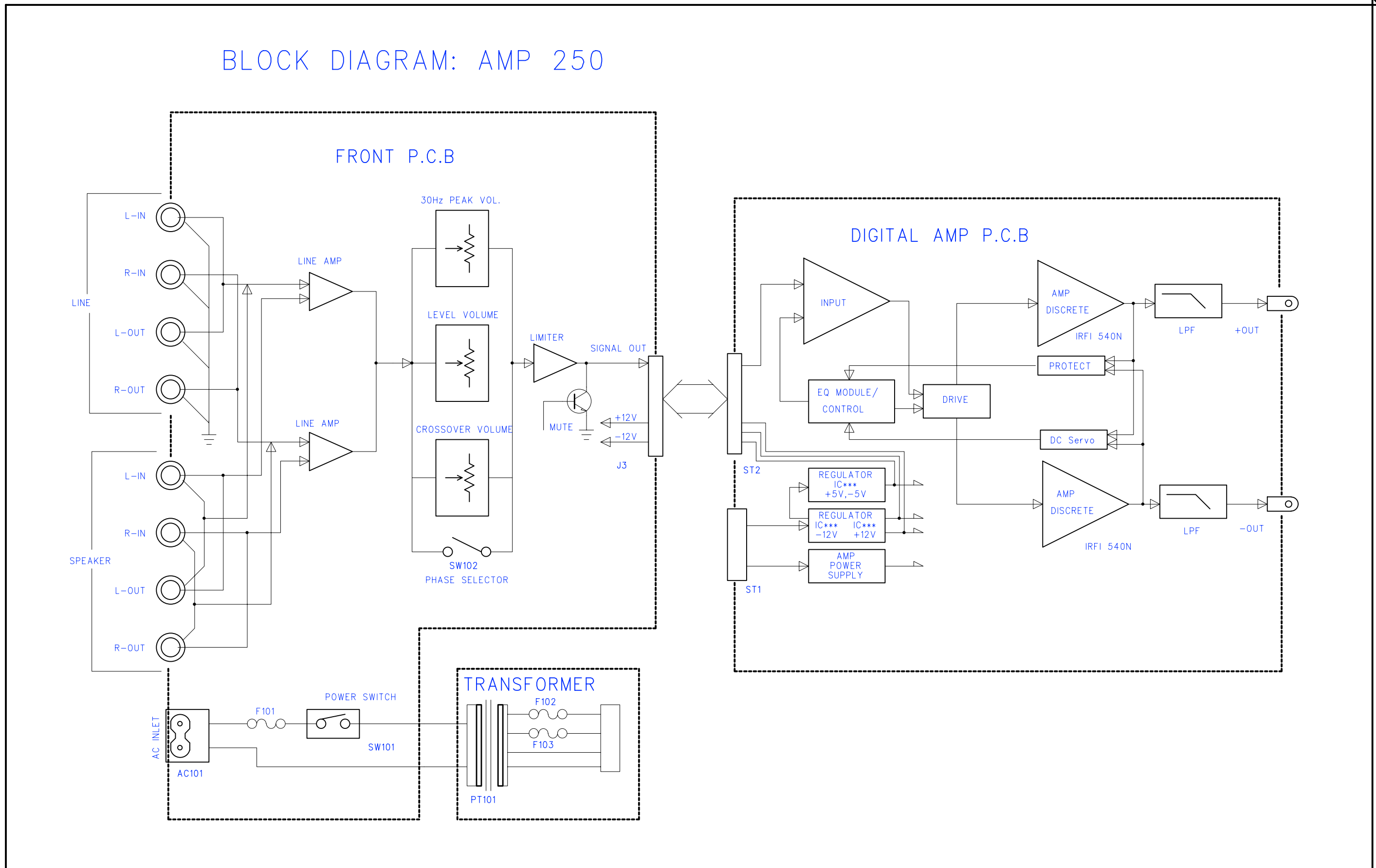

CONFIDENTIAL/CONTROL COPY				
FILENAME AMP250BK.SCH	CODE NO. GBAM-K1000-A0E	DESIGN		SHEET 1 / 1
MODEL AMP 250	DESIGN HyungWon Kang	CHKD	CHKD	APPROVAL
DESIGN DATE 2000.07.11	2000.07.11			2000.07.12

3				2				1			
NO	DATE	POS.	CONTENTS	NO	DATE	POS.	CONTENTS	NO	DATE	POS.	CONTENTS

WIRING DIAGRAM:AMP 250

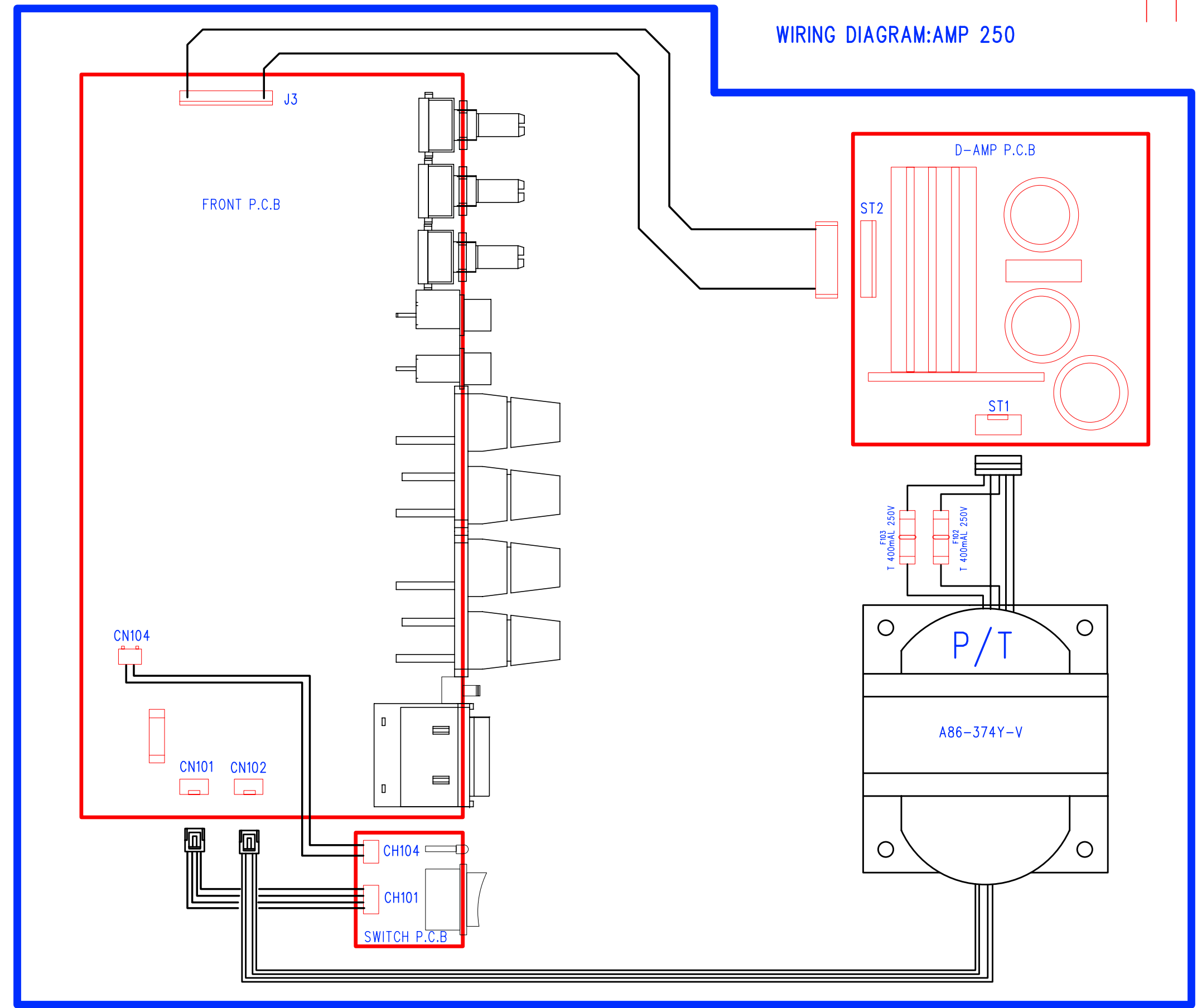

CONFIDENTIAL/CONTROL COPY			
FILENAME AMP250WIJOB	CODE NO. GWAM-K1000-A0E	SHEET 1 / 1	
MODEL AMP-250	DESIGN HyungWon Kang	CHKD 2000.07.12	APPROVAL 2000.07.12
DESIGN DATE 2000.07.11	2000.07.11	2000.07.12	2000.07.12

CIRCUIT DIAGRAM: AMP-250 DIGITAL AMPLIFIER(MP 2000.07.11)

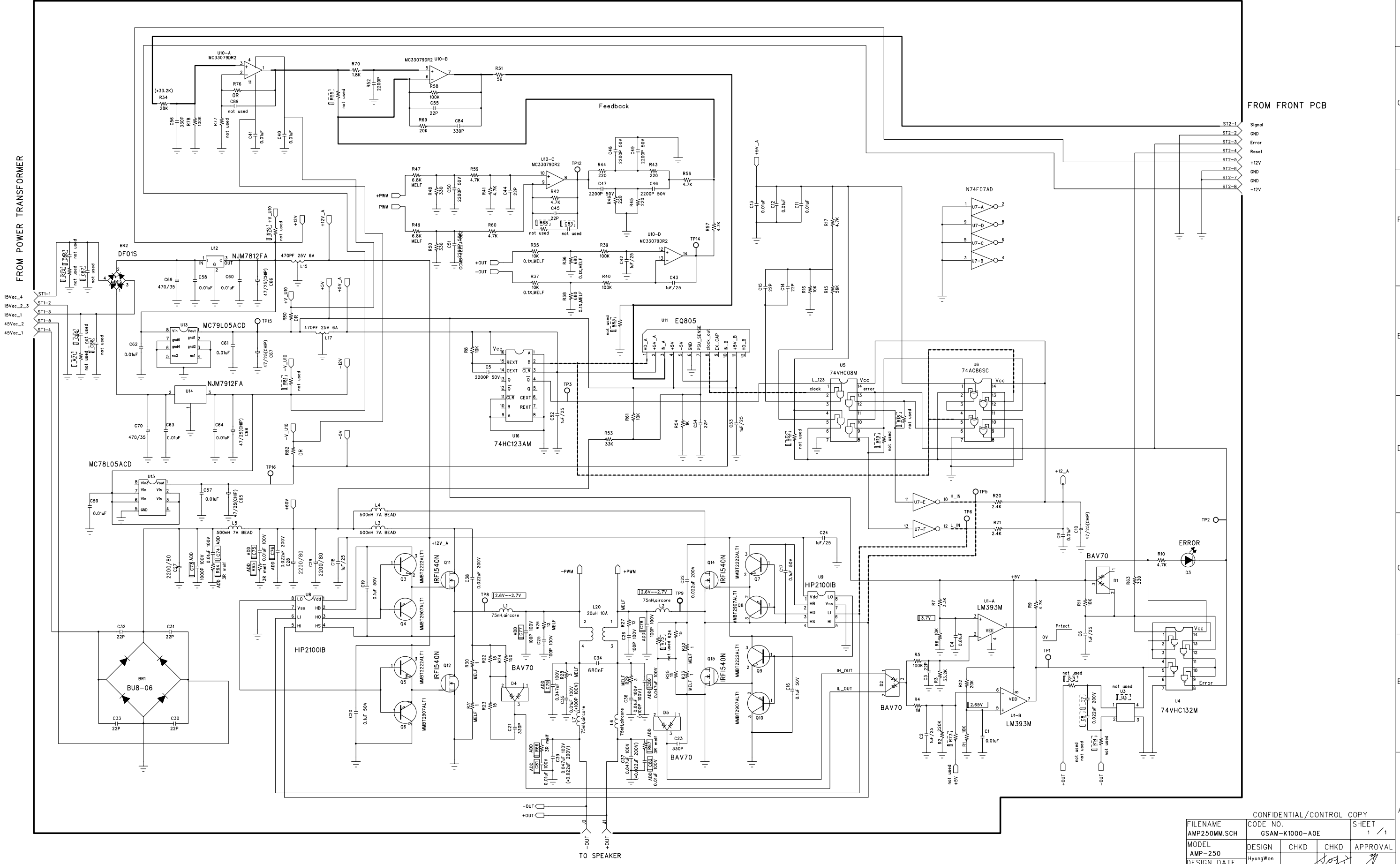

CONFIDENTIAL/CONTROL COPY					
FILENAME	AMP250MM.SCH	CODE NO.	GSAM-K1000-A0E	SHEET	1 / 1
MODEL	AMP-250	DESIGN	CHKD	CHKD	APPROVAL
DESIGN DATE	2000.07.11	HyungWan Kang	2000.07.12	2000.07.12	

NO	DATE	POS.	CONTENTS	NO	DATE	POS.	CONTENTS

CIRCUIT DIAGRAM: AMP-250 FRONT (MP 07-11-2000)

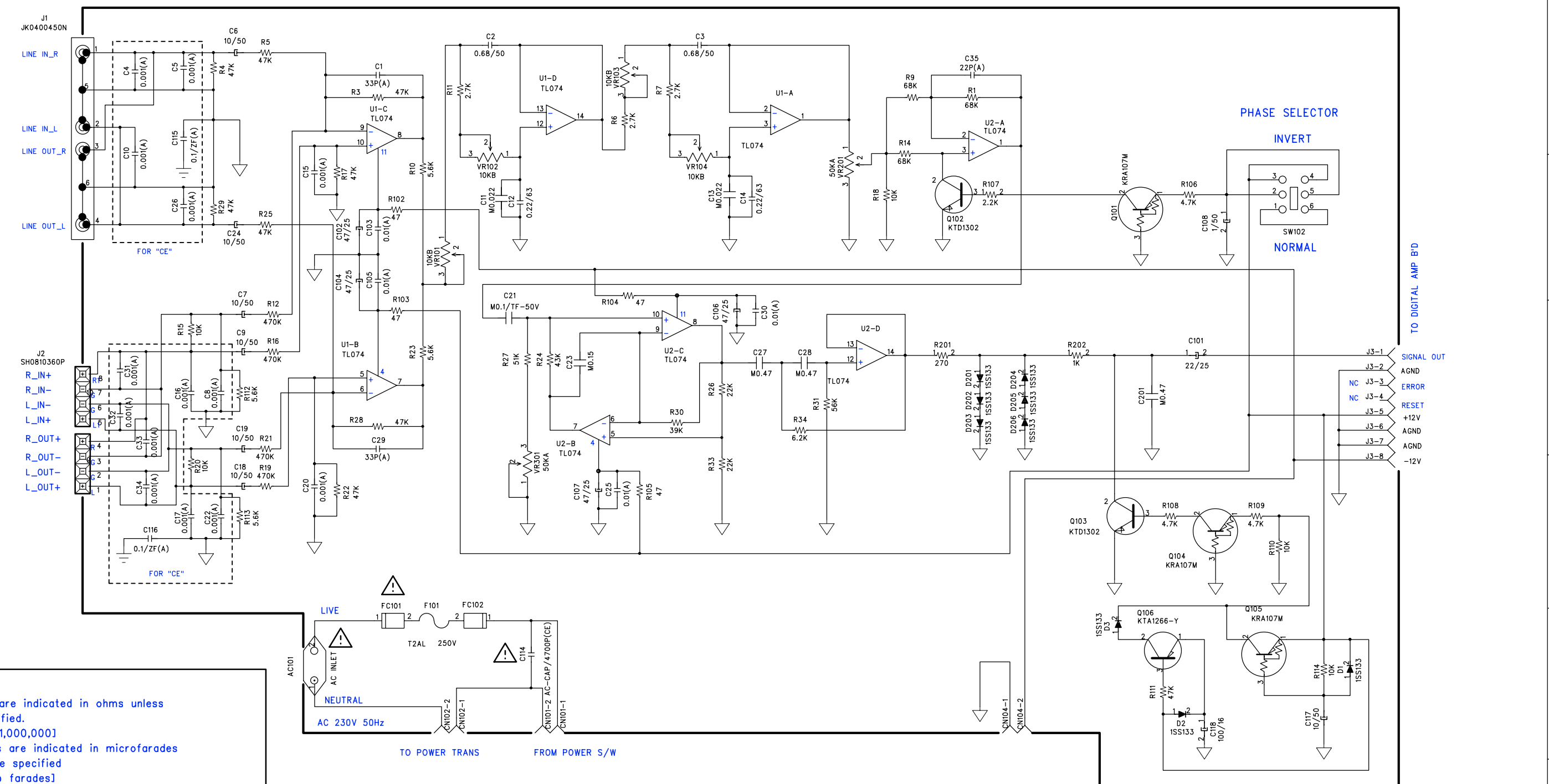

NOTES

- Resistor values are indicated in ohms unless otherwise specified.
[K=1,000 M=1,000,000]
- Capacitor values are indicated in microfarades unless otherwise specified
[p=micro-micro farades]

CAUTION

Safety precaution to be followed during servicing

- Since those parts marked with are critical parts for safety. Use only the one described in the parts list.
- Before returning the set to the customer make appropriate leakage current or resistance measurements to determine the exposed parts are properly insulated from the supply circuit.

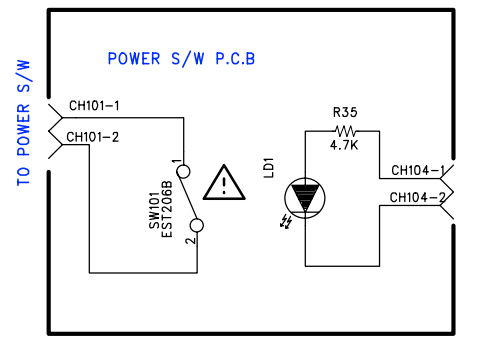
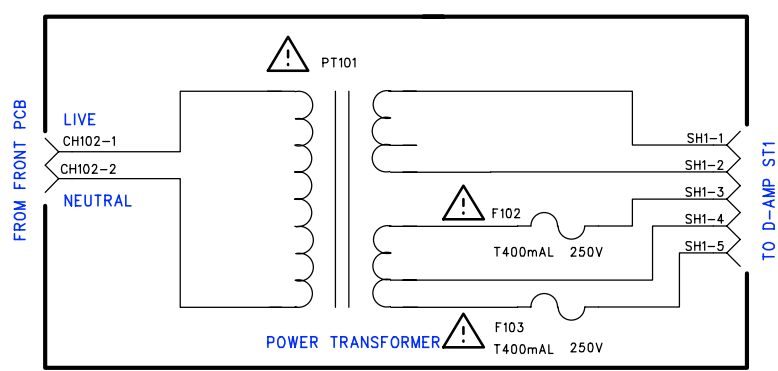
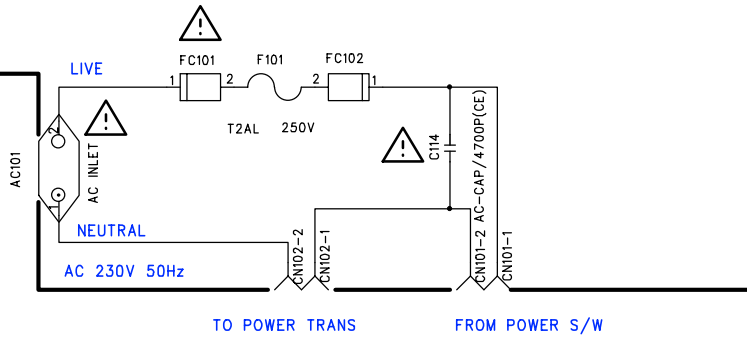

CONFIDENTIAL/CONTROL COPY			
FILENAME AMP250FM.SCH	CODE NO. GSAM-K1000-B0E	SHEET 1 / 1	
MODEL AMP250(FRONT)	DESIGN HyungWan Kang	CHKD	APPROVAL
DESIGN DATE 2000.07.11	2000.07.11	2000.07.12	2000.07.12

NO	DATE	POS.	CONTENTS	NO	DATE	POS.	CONTENTS

LAYOUT DIAGRAM:AMP 250 FRONT P.C.BOARD

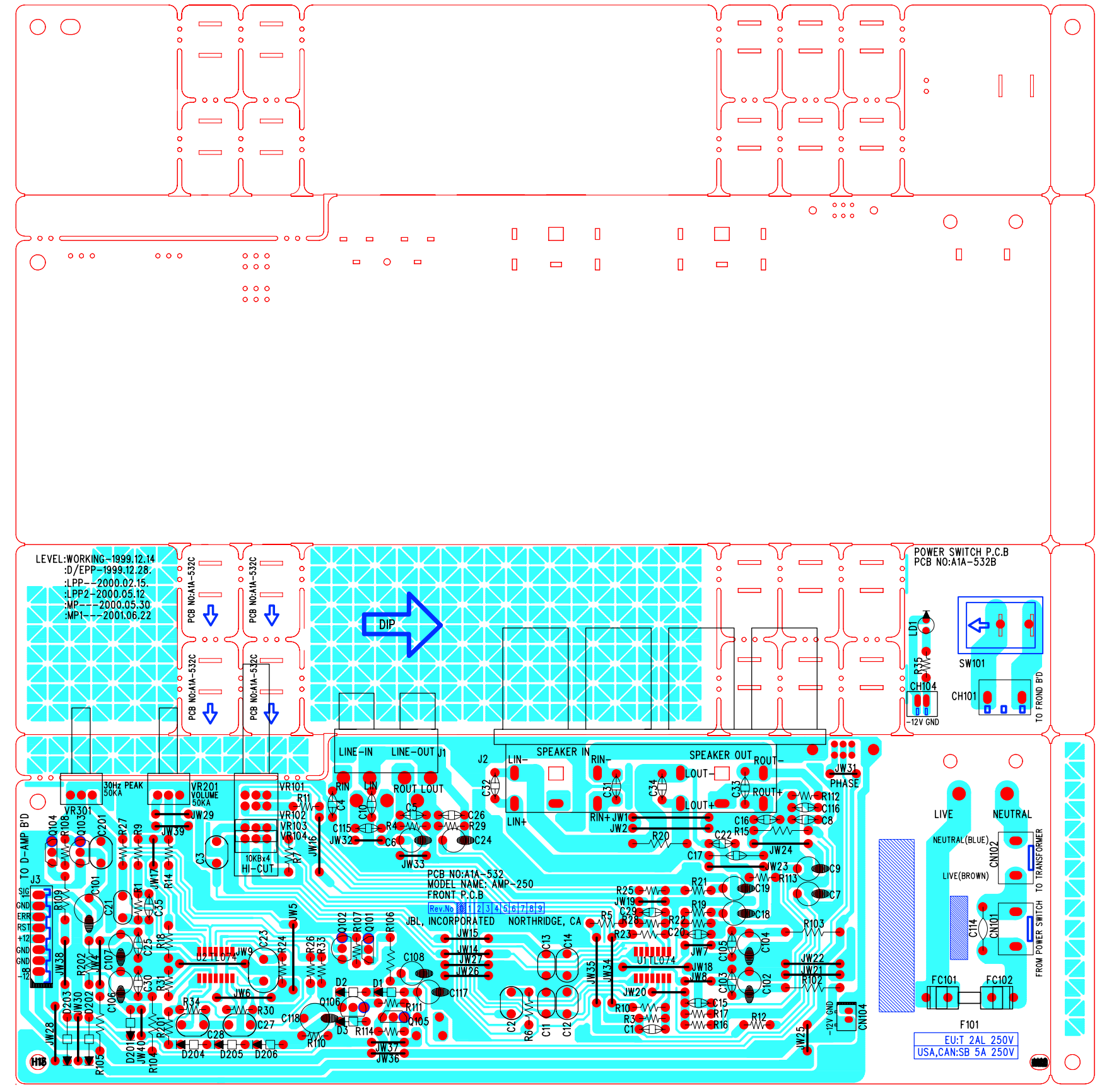

LEVEL:WORKING-1999.12.14
 :D/EPP-1999.12.28
 :LPP2-2000.02.15
 :LPP2-2000.05.12
 :MP-2000.05.30
 :MP1-2001.06.22

POWER SWITCH P.C.B
 PCB NO:A1A-532B

PCB NO:A1A-532
 MODEL NAME: AMP-250
 FRONT P.C.B
 Rev.No 111231416171819
 JBL, INCORPORATED
 NORTHBRIDGE, CA

F101
 EU:T 2AL 250V
 USA,CAN:SB 5A 250V

CONFIDENTIAL/CONTROL COPY				
FILENAME	CODE NO.	SHEET		APPROVAL
AMP25FM_A.pcb	GLAM-K1000-BOE	1 / 1		
MODEL	DESIGN	CHKD	CHKD	
AMP 250				
DESIGN DATE				
2001.06.29	HyungWan Kang			
	2001.06.29			