

JVC

SERVICE MANUAL

INTEGRATED AMPLIFIER

AX-SD1GD

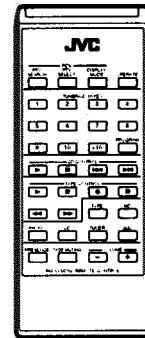
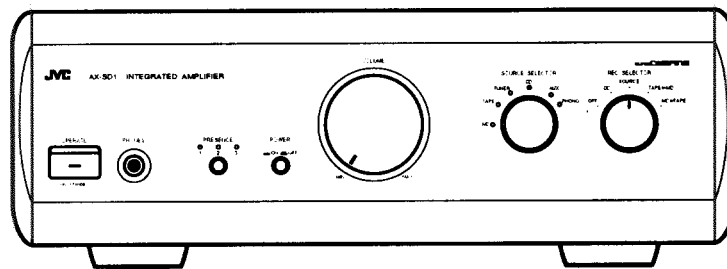

COMPU LINK
 Remote Control Component

Area Suffix

BS the U.K.
 EN Nordic Countries

Contents

<i>Safety Precautions</i>	1-2	<i>Disassembling diagram for workings</i>	2-15
<i>Instruction Book</i>	1-3	<i>PCB. diagram for workings</i>	2-16
<i>Description of Major LSIs</i>	2-1	<i>Block Diagram</i>	2-20
<i>Cautions for Services</i>	2-4	<i>Disassembly Procedures</i>	2-21
<i>Insulation Check for Power Transistor</i>	2-5	<i>Adjustment Procedures</i>	2-25
<i>Amplifier's Conductive Check</i>	2-6	<i>Schematic Diagrams</i>	2-27
<i>Some working points</i>		<i>Printed Circuit Boards</i>	2-30
<i>which affect sound Quality</i>	2-7	<i>Parts List</i>	3-1
<i>Wiring</i>	2-9		

Safety Precautions

1. The design of this product contains special hardware and many circuits and components specially for safety purposes. For continued protection, no changes should be made to the original design unless authorised in writing by the manufacturer. Replacement parts must be identical to those used in the original circuits.
2. Any unauthorised design alterations or additions will void the manufacturer's guarantee ; furthermore the manufacturer cannot accept responsibility for personal injury or property damage resulting therefrom.
3. Essential safety critical components are identified by (Δ) on the Parts List and by shading on the schematics ,and must never be replaced by parts other than those listed in the manual. Please note however that many electrical and mechanical parts in the product have special safety related characteristics . These characteristics are often not evident from visual inspection . Parts other than specified by the manufacturer may not have the same safety characteristics as the recommended replacement parts shown in the Parts List of the service manual and may create shock , fire , or other hazards .
4. The leads in the products are routed and dressed with ties, clamps, tubings, barriers and the like to be separated from live parts, high temperature parts, moving parts and/or sharp edges for the prevention of electric shock and fire hazard. When service is required, the original lead routing and dress should be observed, and it should be confirmed that they have been returned to normal, after re-assembling.

Warning

1. Service should be performed by qualified personnel only.
2. This equipment has been designed and manufactured to meet international safety standards.
3. It is the legal responsibility of the repairer to ensure that these safety standards are maintained.
4. Repairs must be made in accordance with the relevant safety standards.
5. It is essential that safety critical components are replaced by approved parts.
6. If mains voltage selector is provided, check setting for local voltage.

Warnings, Cautions and Others
Warnung, Achtung und sonstige Hinweise
Mises en garde, précautions et indications diverses
Waarschuwingen, voorzorgen en andere mededelingen
Avisos, precauciones y otras notas
Avvertenze e precauzioni da osservare
Varningar, att observera och övrigt
Varoitukset, huomautukset, yms
Advarsler, forsigtighedsregler og andet

IMPORTANT for the U.K.
DO NOT cut off the mains plug from this equipment. If the plug is cut to reach the power point in your home or the cable is too short to reach the power point, then use the appropriate safety approved extension lead or consult your dealer.
BE SURE to replace the fuse only with an identical approved type, as originally fitted.
 If nonetheless the mains plug is cut off ensure to remove the fuse and dispose of the plug immediately, to avoid a possible shock hazard by inadvertent connection to the mains supply.
 If this product is not supplied fitted with a mains plug then follow the instructions given below:
IMPORTANT.
DO NOT make any connection to the terminal which is marked with the letter E or by the safety earth symbol or coloured green or green-and-yellow.
 The wires in the mains lead on this product are coloured in accordance with the following code:
 Blue : Neutral
 Brown : Live
 As these colours may not correspond with the coloured markings identifying the terminals in your plug proceed as follows:
 The wire which is coloured blue must be connected to the terminal which is marked with the letter N or coloured black.
 The wire which is coloured brown must be connected to the terminal which is marked with the letter L or coloured red.
IF IN DOUBT - CONSULT A COMPETENT ELECTRICIAN.

Caution – POWER and OPERATE switches!
 This apparatus is provided with a POWER switch to be able to minimize power consumption for safe use. Therefore,
 1. When doing initial setting, complete all the connections required, connect the mains plug into the wall outlet, and set the POWER switch to ON. After these, OPERATE will function to turn on standby.
 2. When not in use, set the POWER switch to OFF.
 3. Disconnect the mains plug to shut the power off completely. The POWER and OPERATE switches in any position do not disconnect the mains line.
 4. The power can be remote controlled.

Achtung – POWER- und OPERATE-Schalter!
 Dieses Gerät ist mit einem an der Rückseite befindlichen POWER-Schalter versehen, der sowohl für eine Reduzierung des Stromverbrauchs als auch für einen sicheren Betrieb des Geräts sorgt. Beachten Sie daher die folgenden Hinweise:
 1. Vor der ersten Inbetriebnahme führen Sie alle erforderlichen Anschlüsse aus; verbinden Sie dann den Netzstecker mit der Wandsteckdose und stellen Sie den POWER-Schalter auf ON. Danach kann der OPERATE-Schalter zum Einschalten bzw. für den Bereitschafts-Modus (Standby) verwendet werden.
 2. Bei Nichtverwendung des Geräts stellen Sie den POWER-Schalter auf OFF.
 3. Um die Stromversorgung vollkommen zu unterbrechen, ziehen Sie den Netzstecker aus der Wandsteckdose. Die POWER- und OPERATE-Schalter unterbrechen die Stromversorgung zum Gerät nicht, unabhängig von der Schalterstellung.
 4. Das Ein- oder Ausschalten kann auch über die Fernbedienung vorgenommen werden.

Attention – Commutateurs POWER et OPERATE
 Cet appareil est équipé à l'arrière d'un commutateur POWER qui lui permet de réduire sa consommation d'électricité pour une utilisation plus sûre. Par conséquent,
 1. En procédant au réglage initial, compléter toutes les connexions nécessaires, connecter la fiche secteur dans la prise murale et mettre le commutateur POWER sur ON. Ensuite, il sera possible de contrôler la mise en service ou en veille au moyen du commutateur OPERATE.
 2. Mettre le commutateur POWER sur OFF lorsque l'appareil n'est pas utilisé.
 3. Déconnecter la fiche secteur pour couper complètement le courant. Les commutateurs POWER et OPERATE ne coupent jamais complètement l'alimentation quelles que soient leurs positions.
 4. L'alimentation peut être télécommandée.

Opgelet – POWER en OPERATE schakelaars!
 Dit toestel is voorzien van een POWER schakelaar waarmee u voor de veiligheid het stroomverbruik kunt minimaliseren. Let daarna op de volgende punten:
 1. Bij het installeren van het toestel moet u eerst alle vereiste verbindingen maken en dan pas de stekker van het netsnoer in een stopcontact steken. Druk daarna de POWER schakelaar naar ON. Hierna kunt u met de OPERATE schakelaar de spanning in standby schakelen.
 2. Druk de POWER schakelaar naar OFF wanneer u het toestel niet gebruikt.
 3. Trek de stekker van het netsnoer uit het stopcontact om de spanning geheel uit te schakelen. De POWER en OPERATE schakelaars schakelen de spanning in welks stand gedrukt dan ook niet geheel uit.
 4. U kunt de spanning met de afstandsbediening in- en standby schakelen.

AVVISO
 Per ridurre il rischio di shock elettrici, incendi, ecc...
 1. Non togliete vite, coperchi o la scatola.
 2. Non esponete l'apparecchio alla pioggia e all'umidità.

VIKTIGT
 För att minska risken för elektriska stötar, brand etc.:
 1. Lossa inte skruvar, lock eller hölje.
 2. Utsätt inte enheten för regn eller fukt.

VAROITUS
 Vältää sähköiskun ja tulipalon vaara:
 1. Älä avaa ruuveja tai koteloa.
 2. Älä jätä laitetta sateeseen tai kosteaan paikkaan.

ADVARSEL
 For at reducere faren for elektrisk stød, brand, etc.:
 1. Fjern ikke skruer, dæksler eller kabinet.
 2. Udsæt ikke dette apparat for regn eller fugt.

¡Atención – Interruptores POWER y OPERATE!
 Este aparato dispone de un interruptor POWER que sirve para reducir al mínimo el consumo de corriente y proporcionar así mayor seguridad al usuario. Por lo tanto,
 1. Cuando haga el ajuste inicial, complete todas las conexiones necesarias, conecte la clavija del cable de alimentación a una toma de corriente y ponga el interruptor POWER en ON. Después de hacer esto, OPERATE funcionará para conectar la alimentación y ponerla en espera.
 2. Cuando no utilice el aparato, ponga el interruptor POWER en OFF.
 3. Desconecte la clavija del cable de alimentación para desconectar completamente la alimentación. Los interruptores POWER y OPERATE, cualquiera que sea la posición en la que se encuentren, no desconectarán completamente el aparato de la red de alimentación principal.
 4. La alimentación puede controlarse a distancia.

Attenzione – Gli Interruttori POWER ed OPERATE
 Questo dispositivo possiede un interruttore di alimentazione (POWER). Tenere presente quanto segue.
 1. Durante l'installazione dell'unità, completarsi collegamenti, collegare la spina di alimentazione ad una presa e porre in POWER su ON. Ciò fatto, il tasto OPERATE attiva o porta nel modo di attesa la macchina, ma non la spegne.
 2. Se l'unità non è in uso, porre in l'interruttore l'interruttore POWER su OFF.
 3. Per spegnere completamente l'unità è necessario scollegare il cavo di alimentazione. Né POWER ed OPERATE interrompono completamente l'alimentazione.
 4. L'alimentazione è controllabile col telecomando.

Varning – Strömbrytarna POWER och OPERATE!
 Denna apparat är försedd med huvudströmbrytaren POWER på baksidan för att minimera strömförbrukningen och ge öka hantingen säkrare. Gör därför på följande sätt:
 1. Vid den ursprungliga installationen ska du först utföra alla anslutningar, sedan ansluta kablarna till en vägguttag och slänga ställa strömbrytaren POWER på ON. Därefter kan strömbrytaren OPERATE användas för att slå på eller ställa enheten i beredskapsläge.
 2. Ställ strömbrytaren POWER på OFF när apparaten inte används.
 3. Koppla bort kablarna från vägguttaget för att slå av strömförbehåll och hållt. Strömbrytarna POWER och OPERATE kan inte stänga av strömfödet, oavsett vilket läge de står i.
 4. Strömmen kan slås på och av med fjärrkontrollen.

Huomautus – kytkimet POWER ja OPERATE!
 Tässä laitteessa on POWER-kytkin, jonka avulla saadaan vähennettyä virrankulutusta ja varmistettua turvallisen käyttö. Siksi:
 1. Kun teet alkusäätöjä, suorita kaikki tarpeelliset liännöt, kytkie verkkokohjo seinäpistorasiaan ja aseta POWER-kytkin asentoon ON. Tämän jälkeen OPERATE kytkie virran päälle/valmiustilaan.
 2. Kun laitetta ei käytetä, aseta POWER-kytkin asentoon OFF.
 3. Irrota verkkokohjo, kun haluat katkaista virran kokonaan. Kytkinät POWER ja OPERATE eivät missään asennossa katkaise laitteita kokonaan irri verkkovirrasta.
 4. Virta voidaan kytkä ja katkaista kauko-ohjaimella.

Advarsel – knapperne POWER og OPERATE!
 Dette apparat er udstyret med en POWER-knap på bagsiden for at opna et minimalt strømforbrug og sikker anvendelse. Tagt derfor følgende:
 1. Fuldfor ved den indledende indstilling de nødvendige tilslutninger, sæt netledningsskiftet i en stikkontakt i væggen og tryk POWER-knappen til stilling ON. Derefter vil OPERATE-knappen anvendes til at tænde for apparatet/indsille det til standby.
 2. Sæt POWER-knappen i stilling OFF, når apparatet ikke anvendes.
 3. Tag netledningen ud af forbindelse for at afbryde strømforbrugen helt. Strømforsyningen afbrydes ikke, ligegyldigt hvilken stilling POWER- og OPERATE-knapperne sættes i.
 4. Strømforsyningen kan styres med fjernbetjeningen.

Table of Contents

Precaución: Ventilación Adeuada
 Para evitar el riesgo de choque eléctrico e incendio e incendio y para proteger el aparato contra daños.
 Ubique el aparato de la siguiente manera:
 Frente: Espacio abierto sin obstrucciones
 Lados: 10 cm sin obstrucciones a los lados
 Parte superior: 10 cm sin obstrucciones en la parte superior
 Parte trasera: 15 cm sin obstrucciones en la parte trasera
 Fondo: Sin obstrucciones, colóquelo sobre una superficie nivelada
 Además, mantenga la mejor circulación de aire posible como se ilustra.

Precaution: Proper Ventilation
 To avoid risk of electric shock and fire and to protect from damage.
 Locate the apparatus as follows:
 Front: No obstructions open spacing.
 Sides: No obstructions in 10 cm from the sides.
 Top: No obstructions in 10 cm from the top.
 Back: No obstructions in 15 cm from the back.
 Bottom: No obstructions, place on the level surface.
 In addition, maintain the best possible air circulation as illustrated.

Attenzione: Problemi di Ventilazione
 Per evitare il rischio di folgorazioni ed incendi e proteggere l'unità da danni, installarla nel modo seguente.
 Davanti: Nessun ostacolo, spazio libero
 Lati: Nessun ostacolo per almeno 10 cm
 Sopra: Nessun ostacolo per almeno 10 cm
 Retro: Nessun ostacolo per almeno 15 cm
 Fondo: Libero ed in piano
 Inoltre, mantenerla il più possibile la circolazione dell'aria.

Achtung: Angemessene Ventilation
 Stellen Sie das Gerät zur Verhütung von elektrischem Schlag und Feuer und zum Schutz gegen Beschädigung wie folgt auf.
 Vorderseite: Offener Platz ohne Hindernisse
 Seiten: Keine Hindernisse innerhalb 10 cm von den Seiten.
 Rückseite: Keine Hindernisse innerhalb 10 cm von der Rückseite.
 Unterseite: Keine Hindernisse. Auf eine ebene Oberfläche stellen.
 Zusätzlich die bestmögliche Luftzirkulation wie gezeigt erhalten.

Warning: Orienting ventilation
 Place the apparatus in the following way to avoid the risk of electric shock and fire and to protect the unit from damage.
 Front: Open space without any obstruction.
 Sides: No obstruction within 10 cm from the sides.
 Back: No obstruction within 10 cm from the back.
 Bottom: No obstruction. Place on a flat surface.
 In addition, maintain the best possible air circulation as illustrated.

Attention: Ventilation Correcte
 Pour éviter les chocs électriques, l'incendie et tout autre dégât.
 Disposer l'appareil en tenant compte des impératifs suivants.
 Avant: Rien ne doit gêner le dégagement
 Flancs: Laisser 10 cm de dégagement latéral
 Dessus: Laisser 10 cm de dégagement supérieur
 Arrière: Laisser 15 cm de dégagement arrière
 Dessous: Rien ne doit obstruer par dessous; poser l'appareil sur une surface unie.
 Veillez également à ce que l'air circule au maximum comme sur le croquis ci-joint.

Huomautus: Riittävä ilmanvaihto
 Sijaita laite seuraavalla tavalla, jotta saadaan vältettyä sähköisku- ja tulipaloa vaara ja suojattua laite vaurioilta.
 Edessä: Esteetön avoin tila
 Sivulla: 10 cm avoin tila sivuista
 Päällä: 10 cm avoin tila laitteen pinnasta
 Takana: 15 cm avoin tila laitteen takaseinästä
 Pohjassa: Esteetön tasainen pinta
 Ilmanvaihto on lisäksi pidettävä riittävässä kuvassa näytetyllä tavalla.

Opgelet: Zorg Voor Goede Ventilatie
 Om gevaar voor brand of een elektrische schok te voorkomen, dient u bij opstelling van het apparaat op de volgende punten te letten:
 Voorkant: Voldoende ruimte vrij houden.
 Zijkanten: Minstens 10 cm aan weerszijden vrij houden.
 Bovenkant: Niets bovenop plaatsen; 10 cm speling geven.
 Achterkant: Minstens 15 cm ruimte achteraan vrij houden.
 Onderkant: Opstellen op een egaal horizontaal oppervlak.
 Bovendien moet er rondom voldoende luchttoevoer zijn, zoals in de afbeelding aangegeven.

Advarsel: Tilstrækkelig ventilation
 Anbring apparatet som anviset herunder, således at risiko for elektriske stød og brand samt beskadigelse undgås.
 Forsiden: Abent sted uden forhindringer.
 Sider: Ingen forhindringer indentor 10 cm fra siderne.
 Oversiden: Ingen forhindringer indentor 10 cm fra oversiden.
 Bagsiden: Ingen forhindringer indentor 15 cm fra bagsiden.
 Undersiden: Ingen forhindringer. Anbringings på en plan flade.
 Sørg derudover altid for bedst mulig luftcirkulation som vist på illustrationen.

Spacing 15 cm or more
 Abstand von 15 cm oder mehr
 Dégagement de 15 cm ou plus
 Minstens 15 cm lussenuimte
 Espacio de 15 cm o más
 15 cm di distanza o più
 Vrij 15 cm afstand
 Yli 15 cm tilstrækkelig
 Afstand på 15 cm eller mere

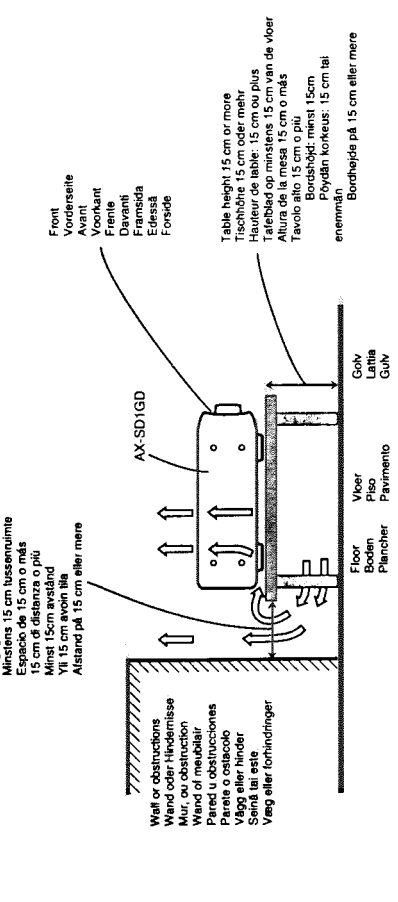

General Information 2
 Welcome 1 2
 Important cautions 2
 For safe use, observe the following 2

Names of Parts 3
 Amplifier: Front panel 3
 Amplifier: Rear panel 4
 Amplifier: Remote control 5

Connections 6
 Before making any connections 6
 Playback connections 6
 Record and playback connections 6
 Record player connections 7
 Speaker connections 7
 Amplifier: Power connections 8
 Remote control batteries 8

Operations 9
 Turning on the amplifier 9
 Selecting a playback source 9
 Adjusting the volume 10
 Selecting the sound mode 10
 Selecting the source to be recorded 11

COMPU LINK Remote Control System 12
 COMPU LINK basics 12
 COMPU LINK versions 12
 COMPU LINK-3 functions 12
 COMPU LINK connections 13
 COMPU LINK operations 13
 COMPU LINK operations using the amplifier's remote control 15

Additional Information 17
 Troubleshooting 17
 Specifications 18
 Block Diagram (Inside back cover)

General Information

Welcome !

We would like to thank you for purchasing one of our JVC products. Before connecting this unit to the wall outlet, please read the instructions carefully to ensure that you obtain the best possible performance. If you have any questions, please consult your JVC dealer.

Important cautions

- Installation of the Unit**
- Select a place which is level, dry and neither too hot nor too cold (Between 5°C and 35°C or 41°F-95°F).
 - Leave sufficient distance between the Unit and a TV.
 - Be sure to place the Unit in a location with good ventilation.
 - Do not use the Unit in a place subject to vibrations.
 - Do not place the Unit on a carpet.
 - Do not place the Unit on top of another heat-generating piece of equipment.

Power cord

- Do not handle the power cord with wet hands!
- When unplugging the Unit from the wall outlet, always pull the plug, not the power cord.

Malfunctions, etc.

- There are no user serviceable parts inside. If anything goes wrong, turn off the power immediately. If the same problem re-occurs when the power is turned on once more, turn off the power again, unplug the power cord and consult your dealer.
- Do not insert any metallic object into the Unit.

For safe use, observe the following

Avoid moisture, water and dust

Do not set your machine in moist or dusty places.

Avoid high temperatures

Do not expose your machine to direct sunlight or set near a heating device.

Do not block the vents

Poor-ventilation may damage your machine. So do not block the vents or put the unit in a poorly ventilated place.

When you're away

When away on travel or otherwise for an extended period of time, set POWER to OFF and pull the plug from the electrical socket.

Do not insert foreign matter into the machine

Do not insert wires, hairpins, coins, etc. into your machine.

Care of the cabinet

When cleaning your machine, use a soft cloth and follow the relevant instructions on the use of chemically-coated cloths. Avoid applying benzene, thinner or other organic solvents and disinfectants. This may cause deformation or discolouring.

If water gets inside the machine

Cut the POWER switch and pull the plug from the electrical socket, then call the store where you made your purchase. Using the machine in this state may cause a fire or electrical shock.

Names of Parts

Amplifier: Front panel

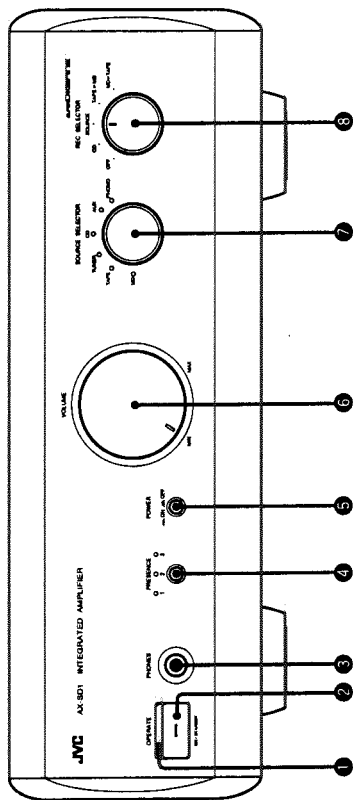

1 Remote sensor

2 OPERATE

Use to switch the amplifier between on and standby. The indicator on the button lights red in standby mode or orange when the power is on (see page 9).

3 PHONES

Outlet for connecting headphones. When headphones are connected, no sound will be output from the speakers.

4 PRESENCE

Use to select the type of sound you desire (see page 10).

5 POWER

Press this button to put the amplifier in standby (see page 9).

6 VOLUME

Adjusts the volume level (see page 10).

7 SOURCE SELECTOR

Selects the playback source (see page 9).

8 REC SELECTOR

Selects the source to be output to the TAPE OUT (REC) and/or MD OUT (REC) terminals (see page 11).

Amplifier: Remote control

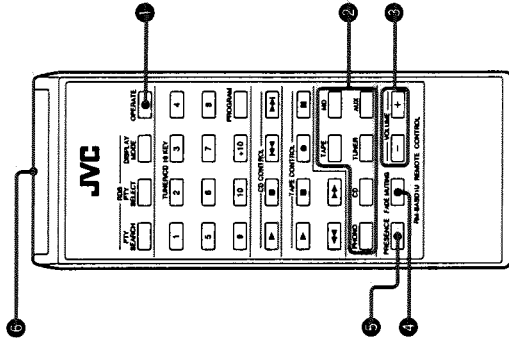

- 1 **OPERATE**
Turns the amplifier on or standby (see page 9).
- 2 **Source select keys**
Use to select the playback source (see page 9).
TAP: to listen to the component (cassette deck) connected to the TAPE terminals.
MD : to listen to the component (MD recorder) connected to the MD terminals.
PHONO : to listen to the component (record player) connected to the PHONO terminals.
CD : to listen to the component (CD player) connected to the CD terminals.
TUNER : to listen to the component (tuner) connected to the TUNER terminals.
AUX : to listen to the component connected to the AUX terminals.
- 3 **VOLUME - / +**
Adjusts the volume of the speakers or headphones (see page 10).
- 4 **FADE MUTING**
Slowly turns the volume all the way down (see page 10).
- 5 **PRESENCE**
Use to select the type of sound you desire (see page 10).
- 6 **Remote control signal emitter**
When operating the remote, point the remote control signal emitter towards the remote sensor on the amplifier.

Buttons not described on this page are for operation of other JVC components. For details, see "COMPU LINK operations using the amplifier's remote control" on page 15.

Amplifier: Rear panel

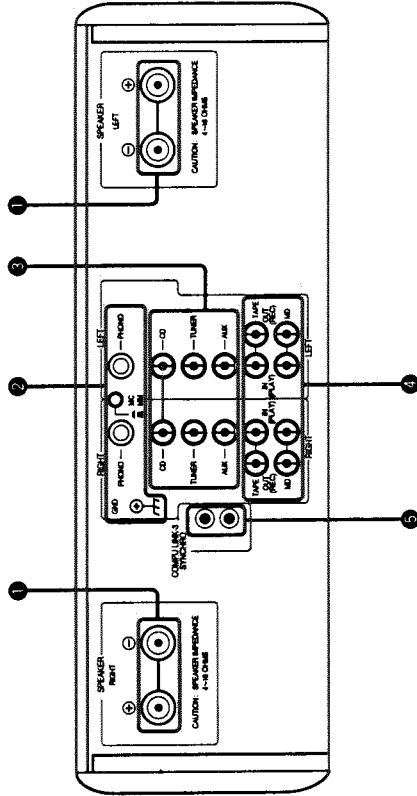

- 1 **SPEAKER**
These terminals output the amplified audio signals. Connect to speakers with an impedance of between 4 and 16 ohms (see page 7).
- 2 **Terminals for connecting a record player**
PHONO : These are input terminals for audio signals from records. Connect to the output cords from the record player (see page 7).
GND : This is a ground terminal for a record player. If your record player has a ground wire, connect it to this terminal (see page 7).
MC/MM : This amplifier can accommodate input from either MC or MM phono cartridges. Set this switch according to the type of cartridge you use (see page 7).
- 3 **Terminals for connecting components for playback and recording**
These are input and output terminals for line level audio signals.
TAPE IN (PLAY) / TAPE OUT (REC) : Connect to the output and input terminals of a cassette deck (see page 6).
MD IN (PLAY) / MD OUT (REC) : Connect to the output and input terminals of an MD recorder (see page 7).
- 4 **COMPU LINK-3 SYNCHRO**
Connect these terminals to other JVC components to take advantage of the COMPU LINK Remote Control System's automatic operation functions (see "COMPU LINK connections" on page 13).
- 5 **Terminals for connecting components for playback**
These are input terminals for line level audio signals.
CD : connect to the output terminals of a CD player (see page 6).
TUNER : connect to the output terminals of a tuner (see page 6).
AUX : connect to the output terminals of an auxiliary component (see page 6).
- 6 **Terminals for connecting components for playback and recording**
These are input and output terminals for line level audio signals.
TAPE IN (PLAY) / TAPE OUT (REC) : Connect to the output and input terminals of a cassette deck (see page 6).
MD IN (PLAY) / MD OUT (REC) : Connect to the output and input terminals of an MD recorder (see page 7).

Connections

Before making any connections

- Be sure to confirm the locations of the left and right, + and -, and IN and OUT terminals on each component and make connections correctly and firmly. Incorrect or incomplete connections may result in degradation of the stereo effect, or no sound at all. As a general rule, use the red plugs on the connecting cords to connect the right channels and the white plugs to connect the left channels.
- Keep tuner, TV, and video deck, antennas away from the amplifier's rear panel and power cord. Nearby antennas can produce noise in the audio signal. Therefore, we also recommend using shielded coaxial antenna cables whenever possible.
- Since different components often have different terminal names, carefully read the instruction manual supplied with the component(s) you are connecting.
- Do not connect the AC power cord until all other connections are complete.
- Use RCA PIN plugs when connecting stereo components to the amplifier.

Playback connections

Connect the CD terminals to the analog line output terminals of the CD player. Connect the TUNER terminals to the line output terminals of the tuner. You can connect the AUX terminals to the analog line output terminals of any auxiliary audio component except a record player.

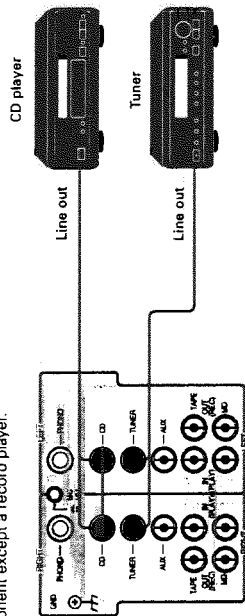

Connections

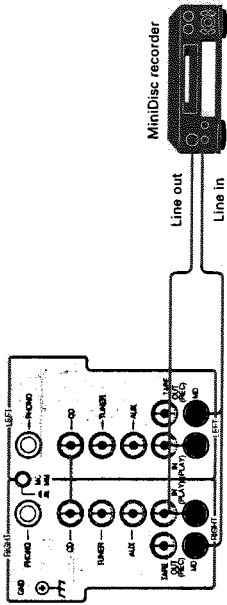

Record player connections

Before connecting a record player, remove the short pins plugged in to the PHONO terminals. Keep the short pins stored in a safe place after removal in case you need them in the future. If you do not connect a record player, leave the short pins in place. This prevents the phono equalizer from consuming extra power and stabilizes the power supply to provide better sound quality. Connect the output cords from the record player to the PHONO terminals and connect the ground wire from the record player to the GND terminal. If your record player does not have a ground wire, this connection is unnecessary. Set the amplifier to OFF or STANDBY, then set the MC/MM switch to either "MC" or "MM" according to the type of cartridge you are using. As a general rule, set the switch to "MC" if your cartridge has an output voltage of less than 0.5 mV, or set to "MM" if it has an output voltage greater than 0.5 mV.

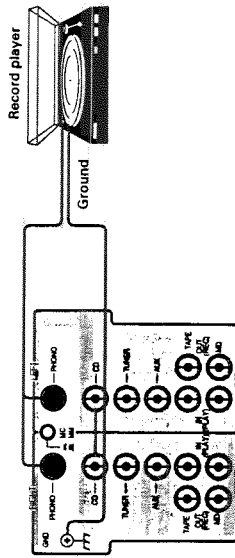

Record and playback connections

Connect the TAPE IN (PLAY) terminals to the line out terminals of the cassette deck. Then connect the TAPE OUT (REC) terminals to the line in terminals of the cassette deck. Connect the MD IN (PLAY) terminals to the line out terminals of the MiniDisc recorder. Then connect the MD OUT (REC) terminals to the line in terminals of the MiniDisc recorder.

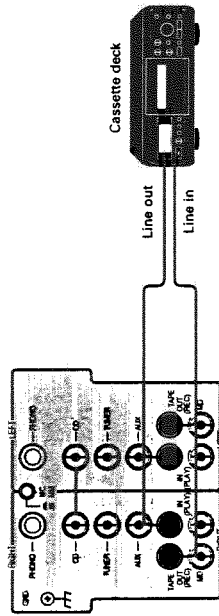

Speaker Connections

Connect the LEFT speaker terminals to the left speaker, and connect the RIGHT speaker terminals to the right speaker. Be sure that the speaker cords do not touch the rear panel of the amplifier. This will damage the amplifier. Be sure to connect the amplifier's + terminals to the + terminals on the speakers, and connect the amplifier's - terminals to the - terminals on the speakers. Connect speakers with an impedance between 4 and 16 ohms.

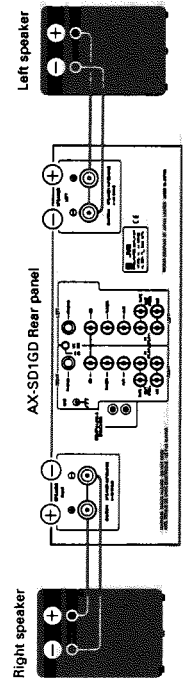

Operations

Turning on the amplifier

- ① Set **POWER** to **ON**.

This lets you use the **OPERATE** button on the front panel (or the remote control) to switch the amplifier **ON** (orange **OPERATE** indicator) and **STANDBY** (red **OPERATE** indicator). When **POWER** is set to **OFF**, the **OPERATE** indicator goes out and **OPERATE** cannot be turned on. You will probably find it most convenient to leave the **POWER** button set to **ON**. However, if you are not going to use the unit for an extended period of time, such as during a vacation, set **POWER** to **OFF** to avoid unnecessary power consumption. A small amount of power (23 watts) is always consumed as long as **POWER** is set to **ON**.



- ② Press **OPERATE** to turn on the amplifier.

The indicator on the button turns orange and the indicator on the **VOLUME** knob flashes red for about 6 seconds while the amplifier warms up. When the indicator on the **VOLUME** knob turns green, sound is output from the speakers (or headphones) connected to the amplifier.

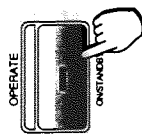

About the VOLUME indicator

The indicator on the **VOLUME** knob shows the operating status of the amplifier.

- When the indicator is green:** The amplifier is operating normally.
- When the indicator is flashes red:** There is an abnormality in the output or equalization stage of the amplifier. Although the indicator flashes red for about 5 seconds after the power is turned on, this is not an abnormality. If the indicator continues flashing red for longer than 5 seconds, turn the power off, unplug the AC power cord, and check the connections. In order to protect the speakers, no signal is output from the **SPEAKER** terminals when the indicator flashes red.

Selecting a playback source

Rotate the **SOURCE SELECTOR** to select the source you desire. When using the remote control, press the source button for the source you desire.

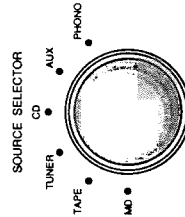

MD

To listen to the component (MD recorder) connected to the MD terminals.

TAPE

To listen to the component (cassette deck) connected to the TAPE terminals.

TUNER

To listen to the component (tuner) connected to the TUNER terminals.

CD

To listen to the component (CD player) connected to the CD terminals.

AUX

To listen to the component connected to the AUX terminals.

PHONO

To listen to the component (record player) connected to the PHONO terminals.



Connections

Amplifier: Power connections

After completing all other connections, connect the power cord to a wall outlet.

Remote control batteries

Load the supplied batteries (2) into the remote control.

- ① Open the battery case

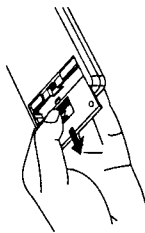

- ② Load the batteries

Match the polarity (+ and -) of the batteries with the + and - marks inside the battery compartment.

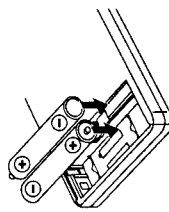

- ③ Close the battery case.

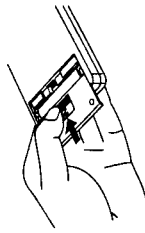

Cautions

- Observe the following to avoid battery leakage or explosion:
- If the range or effectiveness of the remote control decreases, replace the batteries using R03(UM-4)/AAA(24F) type dry cells.
 - Do not use an old battery together with a new one.
 - Do not use different types of batteries together.
 - Do not disassemble the batteries or subject them to high temperatures, like an open fire.
 - Remove the batteries if the remote control will not be used for a long time.

Adjusting the volume

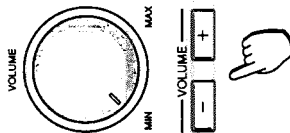

Rotate **VOLUME** to adjust the volume to the level you desire. When using the remote control, press **VOLUME +** or **-** to adjust the volume to the level you desire.



To mute the sound
You can mute the sound by pressing **FADE MUTING** on the remote control. When you press **FADE MUTING**, the volume slowly rotates to the **MIN** position. To raise the volume, press **VOLUME +**.

Selecting the sound mode



Press **PRESENCE** to select the type of sound you desire. The **PRESENCE** modes can be used to compensate for speaker characteristics or to accentuate low frequencies when listening at a low volume level, etc. The modes change as follows each time you press **PRESENCE**:

Mode 1 : Emphasizes the high frequencies.

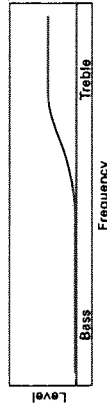

Mode 2 : Emphasizes the low frequencies.

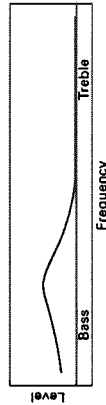

Mode 3 : Emphasizes both high and low frequencies.

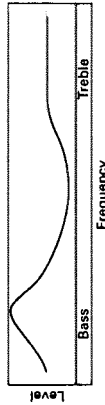

Off : No emphasis

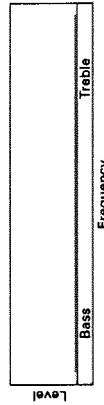

In order to produce higher fidelity recordings, these modes do not effect sound output from the **TAPE** and/or **MD OUT (REC)** terminals during recording.

Selecting the source to be recorded

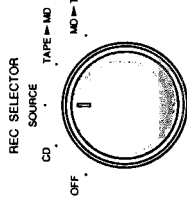

Rotate the **REC SELECTOR** to select the source you desire.

CD

Select to record Compact Discs. The signal input from the **CD** terminals is output to the **TAPE-OUT** and **MD-OUT** terminals.

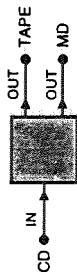

SOURCE

Select to record the source selected with the **SOURCE SELECTOR**. The source signal selected at the **SOURCE SELECTOR** is output to the **TAPE-OUT** and **MD-OUT** terminals.



TAPE ▶ MD

Select to record from cassette tape to MiniDisc. The signal from the **TAPE-IN** terminals is output to the **MD-OUT** terminals.



MD ▶ TAPE

Select to record from MiniDisc to cassette tape. The signal from the **MD-IN** terminals is output to the **TAPE-OUT** terminals.

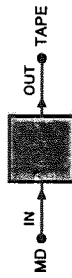

OFF

Set to this position when not recording. Turning off the recording selector provides better sound quality by excluding unnecessary circuitry from the signal path.

To check the sound being recorded

You can check the sound being recorded when the **REC SELECTOR** is set to either **CD** or **MD** ▶ **TAPE**. Just use the **SOURCE SELECTOR** to select the recording component, and you can hear the signal being output to that component, or the tape monitor (if the recording component is a 3 head cassette deck).

Note

There is a momentary silence when you switch the **REC SELECTOR**, but this is not a malfunction.

COMPU LINK Remote Control System

COMPU LINK basics

Buying a separate CD player, cassette deck, MD recorder, amplifier, etc., is a good way to enjoy high-quality sound from the exact combination of components you want. However, since each component has to be operated individually, operation can be somewhat difficult. JVC's COMPU LINK Remote Control System allows you to enjoy the flexibility of single components with the ease of operation found in single unit component systems.

In the descriptions and instructions that follow, the COMPU LINK Remote Control System is referred to as 'COMPU LINK' for the sake of convenience.

Products that are compatible with COMPU LINK have terminals marked either COMPU LINK-1, COMPU LINK-2, or COMPU LINK-3 (referred to collectively as COMPU LINK terminals). Linking components by the COMPU LINK terminals, allows simplified collective operation, like that of a single unit component system.

COMPU LINK versions

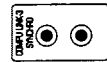

- There are currently three versions of COMPU LINK available from JVC: COMPU LINK-1, COMPU LINK-2, and COMPU LINK-3. COMPU LINK-3 is the newest version, with the most functions.
- You can distinguish the COMPU LINK version by looking at the COMPU LINK terminals of the respective components.

COMPU LINK-3 components may be connected to components with earlier version components, but in this case the newest functions may not work.

COMPU LINK-3 functions

The following is a brief overview of the available functions:

One touch play

Lets you listen to a source component, such as a CD player, without operating the amplifier. All you have to do is start playing the source component (see page 14).

Synchro recording

Lets you start recording automatically when you start playing the source component (see page 14).

Total operation by one remote control

Lets you operate all the source components, such as the CD player, cassette deck, and tuner, from the amplifier's remote control (see page 15).

MiniDisc recorder automatic input switching

When the MiniDisc recorder's input selector is set to digital input, digital signals are input only when the source selector on the amplifier is set to CD. When it is set to other sources, analog signals are input. This saves you the trouble of manually switching the input selector every time you change the source (see page 13).

Timer Operation

Lets you use a component equipped with a timer function to start and stop recording or playback at the time(s) you specify (see the instructions provided with the respective component).

COMPU LINK Remote Control System

Automatic source switching upon reception of desired EON information

When a tuner equipped with RDS EON functions receives the information you desire, the source selector on the amplifier automatically switches to TUNER to allow you to hear the desired information. When the information is over, the amplifier switches back to the previous component (see the instructions provided with an RDS tuner).

COMPU LINK connections

Use COMPU LINK cords for connecting cables with mono mini plugs) to connect the COMPU LINK terminals of each component.

- When there is more than one COMPU LINK terminal, any terminal can be used.
- Be sure to plug the power cords of the component into UNSWITCHED outlets or a wall outlets. If components are plugged into SWITCHED outlets, the COMPU LINK functions will not work properly.
- When components have POWER switches on the rear panel, that switch must be set to ON in order for COMPU LINK to work properly.
- You can connect either a MiniDisc or a DAT deck to this amplifier's MD terminals. If a MiniDisc or DAT deck is connected a different set of line input terminals, the COMPU LINK functions will not work properly.

Note

- You can not connect an MD recorder, DCC deck and DAT deck, into the COMPU LINK system at the same time. Select the component you use most, and connect only that component.
- If no amplifier is connected, only the "synchro recording" function will be operable.
- COMPU LINK timer operation is possible only when a JVC tuner equipped COMPU LINK-3 SYNCHRO terminals and a timer function is connected into the COMPU LINK system.

COMPU LINK Connection example

The following is a basic example of COMPU LINK connections for JVC audio components. With these connections, all the functions are bridged, so there is no set order in which the components must be connected.

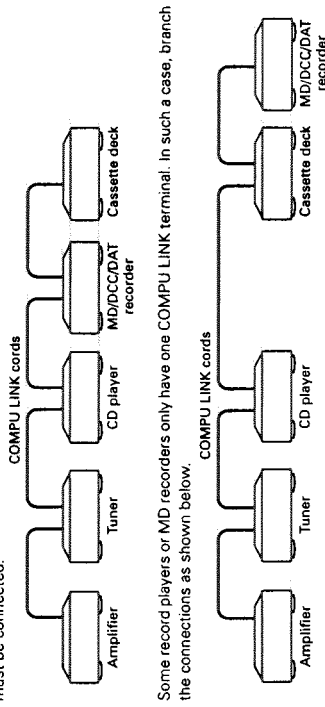

Some record players or MD recorders only have one COMPU LINK terminal. In such a case, branch the connections as shown below.

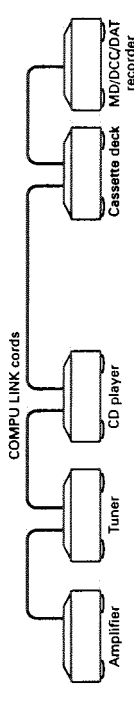

COMPU LINK operations

MiniDisc recorder automatic input switching

The automatic input switching function saves you the trouble of manually switching the input selector when recording to MiniDisc.

- ① Set the input selector on the MiniDisc recorder to digital in (DIGITAL IN).

(continued)

Digital signals are input to the MiniDisc recorder when the amplifier's playback source selector (or record source selector) is set to CD. Analog signals are input when other sources are selected. When the MiniDisc's input selector is set to analog input (ANALOG IN) all input is fixed to analog.

One touch play

The one touch play function lets you listen to a source simply by starting playback from the source component.

- ① Press the play (▶) button on the source component.
(For the tuner, press the band selector (FM or AM) button.)

The following operations are done automatically, all you need to do is enjoy!

- The source component and amplifier turn on.
- The source selector on the amplifier switches to the respective source component.
- The source component starts playing.

Selecting a source component with the amplifier's source selector will also start playback from the respective source. The previous source component stops playing. After the amplifiers turned on, it takes about 5 seconds before any sound is output. Since there will be no sound during this time, even if the source component start playing, the initial section may be left out when playback begins.

Note

If both the amplifier and source component are not COMPU LINK-3 compatible, the power will not turn on automatically. When using components with earlier versions of COMPU LINK, be sure to turn the amplifier and respective components on before operation.

Synchro Recording

The synchro recording function lets you start recording automatically when you start playing the source component. It can also be used for recording PROGRAM play from CD (etc.).

- ① Load a disc or tape into the source component.
- ② Load a disc or tape into the recording component.
- ③ Set the recording component to the record pause (REC PAUSE) mode.
- ④ Press the play (▶) button on the source component.

Recording starts automatically when the source component starts playing.

Notes

- Synchro recording cannot be done to 2 components (such as an MD recorder and cassette deck) at the same time.
- Synchro recording is not possible when the source component is the cassette deck.
- Synchro recording will stop if you change the recording selector during the synchro recording process. With certain amplifiers, the source selector function is locked during the synchro recording process and cannot be changed when the recording selector is set to SOURCE. Please, do not switch the setting of the recording and source selectors while recording.
- When synchro recording PROGRAM play onto a cassette deck, a 4 second space is automatically created between each track. This is to let you locate the beginning of the tracks by using the cassette deck's MUSIC SCAN function after the tape is recorded, it is not a malfunction.

Total operation by one remote control

Refer to the following section "COMPU LINK operations using the amplifier's remote control" starting on page 15 for details regarding the operation of other components with this amplifier's remote control.

COMPU LINK operations using the amplifier's remote control

You can use the remote control supplied with this amplifier to control all of the connected components, such as CD player, cassette deck, and tuner.

Selecting a playback source

The source select keys let you start playback automatically. **TAPE** : turns on the amplifier and cassette deck, then starts playback from the cassette deck.

MD : turns on the amplifier and MD recorder, then starts playback from the MD recorder.

PHONO : turns on the amplifier and selects the record player. **CD** : turns on the amplifier and CD player, then starts playback from the CD player.

TUNER : turns on the amplifier and tuner, then receives the last received station.

AUX : turns on the amplifier and selects the component connected to the AUX terminals.

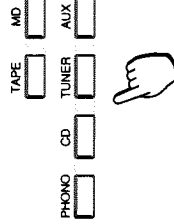

Controlling the tuner

If your tuner has RDS functions, you can use the RDS keys: **PTY SEARCH** : Lets you to search stations by PTY.

PTY SELECT : Selects PTY codes.

DISPLAY MODE : Switches between the time and station information display.

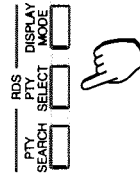

To select a preset station

- ① Press TUNER to select the tuner.



- ② Use the numeric keys to specify the preset number of the station you desire.

For channel 5, press "5".

For channel 20, press "+10", then press "10".

For channel 25, press "+10" twice, then press "5".

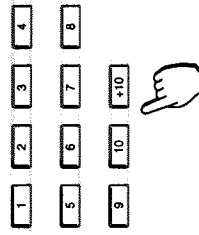

Controlling the cassette deck

These buttons have similar operations as those on the cassette deck's remote control.

▶ : Starts playback. Can also be used to start recording from record pause mode.

■ : Stops playback or recording.

▶▶ : Press together with ▶▶ to start recording or press together with ▶▶ to activate record pause mode. Press during recording or record pause to activate the record mute function and create a 4 second blank.

⏮ : Pauses playback or recording.

⏪ : Rewind during stop mode. Reverse music scan during play mode.

⏩ : Fast forward during stop mode. Forward music scan during play mode.

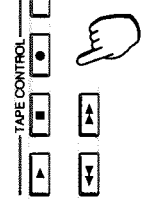

Controlling the CD player

These buttons have similar operations as those on the CD player's remote control.

- ▶▶ : Starts playback
- : Stops playback
- ◀▶ : Moves playback to the beginning of the current or subsequent tracks.
- ▶▶▶ : Moves playback to the beginning of the following tracks.

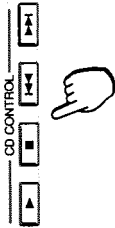

To program the CD player

① Press CD to select the CD player.



② Press CD CONTROL ■ to stop playback.



③ Press PROGRAM.



④ Use the numeric keys to specify the track numbers.
 To program track 5, press "5".
 To program track 20, press "+" + "10", then press "10".
 To program track 25, press "+" + "10" twice, then press "5".
 You can program up to 32 tracks. Each time a track is specified, the programmed track number and the number of programmed tracks appear in the display on the CD player.

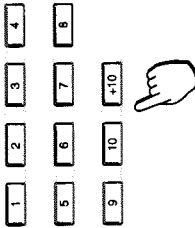

⑤ Press CD CONTROL ▶▶ to start playing the program.



To check the tracks in the program

Press the CD CONTROL ◀▶▶▶ ▶▶▶▶ buttons when the CD is not playing.

To cancel the program

Press PROGRAM when the CD is not playing. Pressing CD CONTROL ■ will not cancel the program.

Additional Information

Troubleshooting

If you experience any difficulty with your amplifier, check the following list for a possible solution before calling for service. If you cannot solve the problem from the hints given here, or the amplifier has been physically damaged, call a qualified person, such as your dealer, for service.

SYMPTOM	POSSIBLE CAUSE	ACTION
Amplifier does not respond	<ul style="list-style-type: none"> • The power cord is disconnected. • POWER switch is set to OFF. • OPERATE switch is set to STANDBY. 	<ul style="list-style-type: none"> • Connect the power cord. • Set POWER switch to ON before pressing OPERATE. • Press OPERATE to turn the power ON.
No sound	<ul style="list-style-type: none"> • Connections are incorrect or incomplete. • The volume control is turned all the way down. • The speaker cords are disconnected. 	<ul style="list-style-type: none"> • Check to make sure the all equipment is connected correctly. • Turn VOLUME to the right • Connect the speaker cords.
Sound placement and/or motion is undefined	<ul style="list-style-type: none"> • The polarity (+, -) of one speaker is reversed. 	<ul style="list-style-type: none"> • Make sure both speaker are connected with the correct polarity.
Remote does not work	<ul style="list-style-type: none"> • Batteries are exhausted. • Battery polarity (+, -) is reversed. • Incorrect operation. 	<ul style="list-style-type: none"> • Replace the batteries. • Reinsert batteries correctly. • Point remote at the remote sensor on the amplifier and make sure there are no obstructions between the remote and amplifier
The sound level from the record player is too low/high.	<ul style="list-style-type: none"> • The remote sensor is in direct sunlight. • The MC/MM switch is set incorrectly. 	<ul style="list-style-type: none"> • Keep the remote sensor away from direct sunlight. • Set the MC/MM switch correctly.

Additional Information

Specifications

Audio performance

Output power

70 watts per channel, min. RMS, both channels driven into 4 ohms at 1 kHz with no more than 0.7% total harmonic distortion (IEC 268-3/DIN);

40 watts per channel, min. RMS, both channels driven into 8 ohms at 1 kHz with no more than 0.7% total harmonic distortion (IEC 268-3/DIN);

35 watts per channel, min. RMS, both channels driven into 8 ohms 20 Hz to 20 kHz with no more than 0.02% total harmonic distortion

Total Harmonic Distortion

CD, TUNER, TAPE, MD, AUX : 0.004% * at 10 watts output (into 8 ohms at 1 kHz)
* Measured by JVC Audio Analysis System

Power Bandwidth

5 Hz to 50 kHz (IHF, both channels driven into 8 ohms, no more than 0.05% total harmonic distortion)

Damping factor

150 at 1 kHz (into 8 ohms)

Frequency Response

CD, TUNER, TAPE, MD, AUX : 0.5 Hz to 150 kHz (+0 dB, -3 dB, into 8 ohms)

Signal-to-Noise ratio

PHONO-MM : 82 dB / 81 dB

(*66 IHF/DIN)

PHONO-MC : 70 dB / —

Audio Input Sensitivity / Impedance

PHONO-MM : 2.5 mV / 47 k ohms

(1 kHz)

PHONO-MC : 0.2 mV / 100 ohms

Recording Output Level / Impedance

CD, TUNER, TAPE, MD, AUX : 400 mV / 33 k ohms

RIAA Phono Equalization

TAPE, MD : 400 mV / 1.6 k ohms

MM, MC : ±0.3 dB (20 Hz to 20 kHz)

General

Power requirements

AC 230 V[~], 50 Hz

Power Consumption

187 watts (OPERATE ON); 23 watts (OPERATE STANDBY)

Dimensions (WxHxD)

360 x 129 x 337 mm (14-3/16 x 5-3/8 x 13-5/16 inches)

Mass

13.6 kg (30 lbs)

Accessories

Remote control unit (RM-SASD1U) 1

Battery (R03(UIM-4)/AAA(24F)) 2

Design and specifications subject to change without notice.

— MEMO —

Description of Major LSIs

■ MN171202K8T (IC701) : SYSTEM CONTROLLER

1. Terminal Layout

5V	1	64	OSC1
PHONO IND	2	63	OSC2
CD	3	62	GND
TUNER	4	61	
AUX	5	60	
TAPE	6	59	AC RELAY
MD	7	58	MUTE
	8	57	SPK RELAY
	9	56	H. P. RELAY
PRESENCE1	10	55	
PRESENCE2	11	54	
PRESENCE3	12	53	VOL DOWN
	13	52	VOL UP
STANDBY IND	14	51	
PROTECT IND	15	50	
VOLUME IND	16	49	
	17	48	DCS OUT
VSS	18	47	DCS IN
KOUT0	19	46	
KOUT1	20	45	INH
KOUT2	21	44	REMOCON
KOUT3	22	43	RESET
KOUT4	23	42	DATA
KOUT5	24	41	STB
	25	40	CLK
	26	39	
S.SELECT0	27	38	
S.SELECT1	28	37	
	29	36	H.P.DETECT
R.SELECT	30	35	PROTECT IN
	31	34	OPERATE SW
	32	33	PRESENCE SW

2. Description

Pin No.	Symbol	I/O	Description	Pin No.	Symbol	I/O	Description
1	5V	--	Power supply	34	OPERATE SW	I	OPERATE switch input
2	PHONO IND	O	PHONO indication control	35	PROTECT IN	I	Protector detection
3	CD	O	CD indication control	36	H.P.DETECT	I	Head phone detection
4	TUNER	O	TUNER indication control	37~39		--	GND
5	AUX	O	AUX indication control	40	CLK	O	Clock to IC131
6	TAPE	O	TAPE indication control	41	STB	O	Strbe signal to IC131
7	MD	O	MD indication control	42	DATA	O	Data to IC131
8		--	GND	43	RESET	I	Reset signal input
9		--	Not used	44	REMOCON	I	Remote signal input
10	PRESENCE1	O	PRESENCE1 indication control	45	INH	I	Inhibit signal input
11	PRESENCE2	O	PRESENCE2 indication control	46		--	GND
12	PRESENCE3	O	PRESENCE3 indication control	47	DCS IN	I	Compulink signal input
13		--	GND	48	DCS OUT	O	Compulink signal output
14	STANDBY IND	O	STANDBY indication control	49~51		--	GND
15	PROTECT IND	O	PROTECTOR indication control	52	VOL UP	O	Volume control signal
16	VOLUME IND	O	VOLUME indication control	53	VOL DOWN	O	Volume control signal
17		--	Not used	54,55		--	Not used
18	VSS	--	GND	56	H.P.RELAY	O	Head phone relay control signal
19~24	KOUT0~5	O	Key output (for Source/Rec select)	57	SPK RELAY	O	Speaker relay control signal
25,26		--	GND	58	MUTE	O	D.Mute circuit control
27	S.SELECT0	I	Key input (for Source select)	59	AC RELAY	O	Audio power relay control signal
28	S.SELECT1	I	Key input (for Source select)	60		--	GND
29		--	GND	61		--	Not used
30	R.SELECT	I	Key input (for Rec select)	62	GND	--	GND
31,32		--	GND	63	OSC2	--	Oscillation terminal
33	PRESENCE SW	I	PRESENCE switch input	64	OSC1	--	Oscillation terminal

AX-SD1GD

■ M5238AL (IC201) : Dual OP Amp.

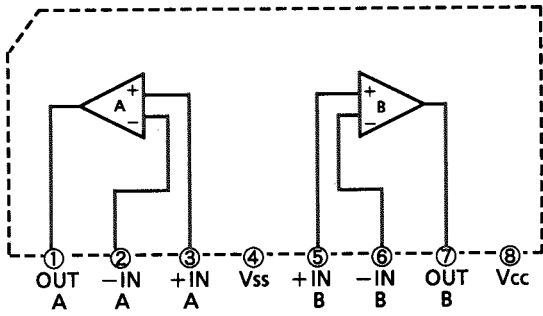

■ PST9140T (IC702) : Reset IC

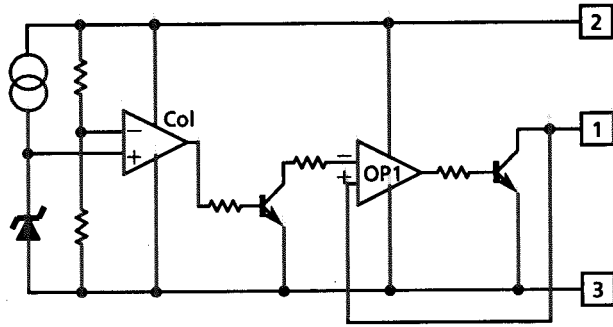

■ TA7317P (IC901) : PROTECTOR

(1) Terminal Layout

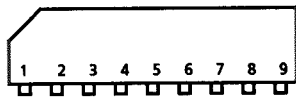

(2) Block Diagram

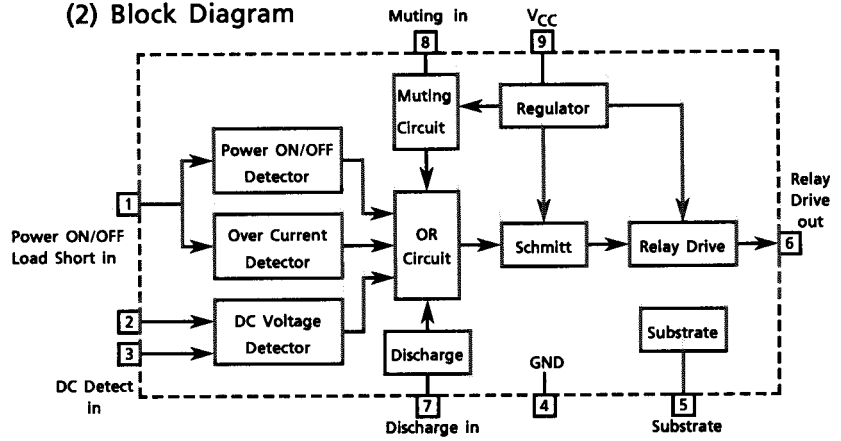

■ VC5022(X,Y) (IC401,402) : SUPER A

(1) Terminal Layout

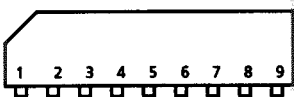

(2) Block Diagram

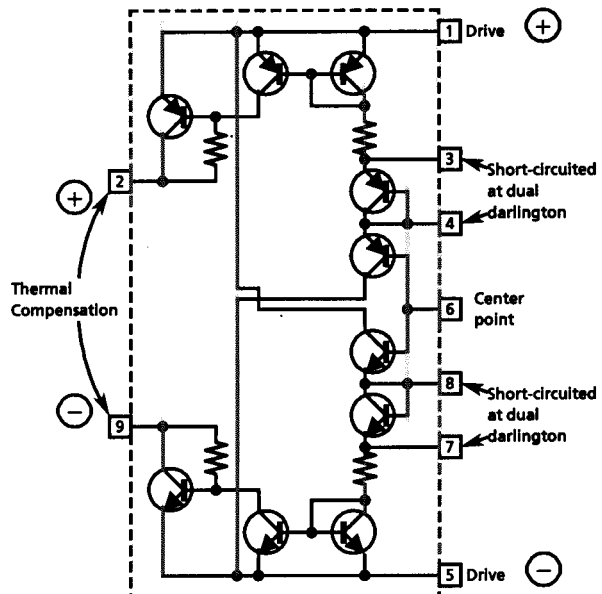

■ LB1639 (IC371) : Motor Driver

1. Terminal Layout

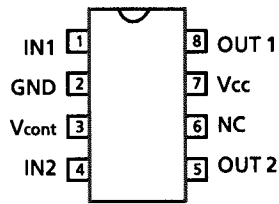

2. Block Diagram

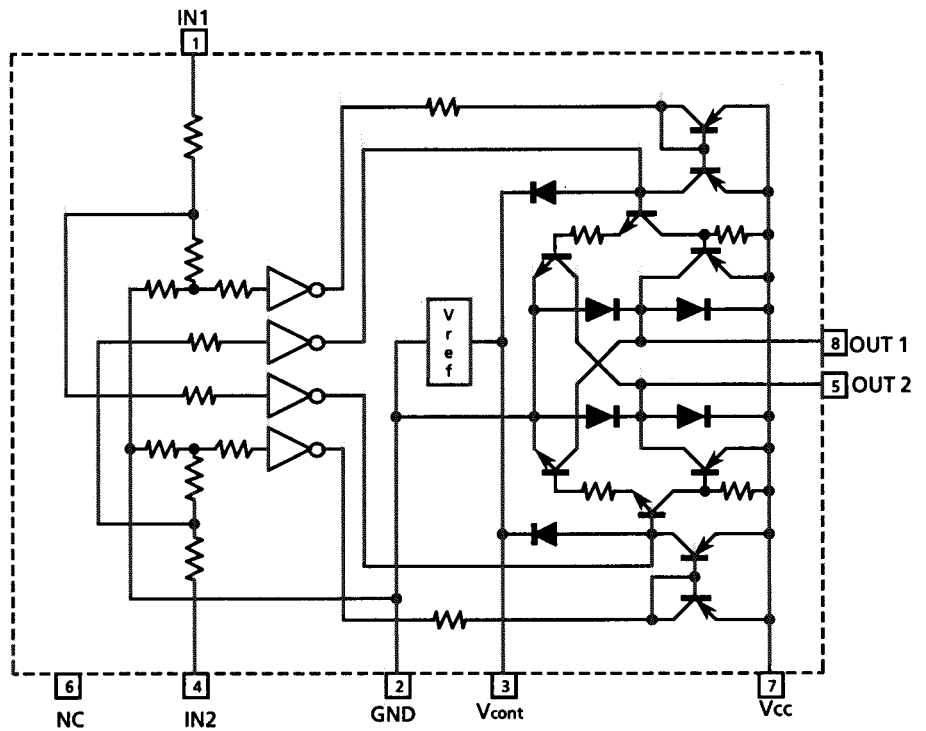

3. Function

IN 1	IN 2	OUT 1	OUT 2	MOTOR
H	L	H	L	CLOCKWISE
L	H	L	H	COUNTER-CLOCKWISE
H	H	OFF	OFF	WAITING
L	L	OFF	OFF	WAITING

■ GP1U501X (IC703) : Receiver for remote controller

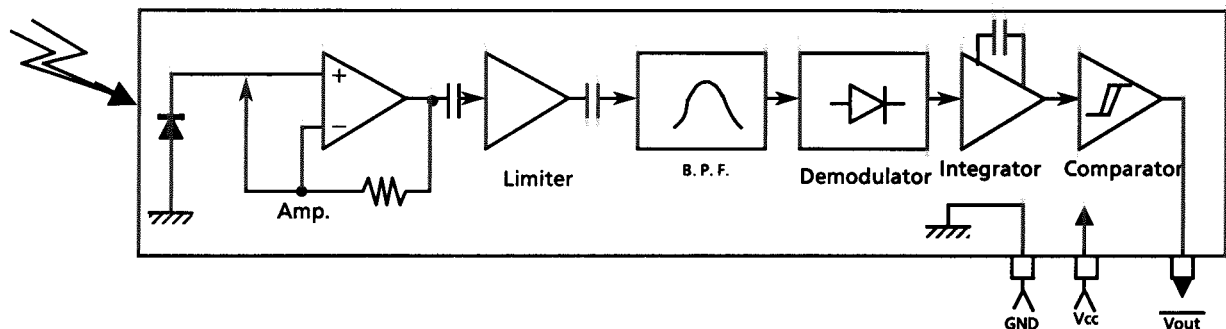

CAUTIONS FOR SERVICES

■ BEFORE SERVICING

1. Conduction check for an amp. is required first when the faulty symptom shows “no sound”.
If the amp. is faulty, the fault will be expanded when you first apply AC230V at the service.

2. It is always needed to discharge power supply condensers(C801/C802/C803/C804/C811/C812) before disconnect the connections.

1) Resistor for discharge : Dummy load of 30~100Ω (approx. 10W)

2) Discharge procedures

ENB-226-2

C801 : Connect the resistor between WT803 and D801 or D803's cathode for discharge.

C802 : Connect the resistor between WT803 and D802 or D804's cathode for discharge.

C803 : Connect the resistor between WT804 and D805 or D807's anode for discharge.

C804 : Connect the resistor between WT804 and D806 or D808's anode for discharge.

ENH-282-3

C811 : Connect the resistor between speaker GND and D816 or D812's anode.

C812 : Connect the resistor between speaker GND and D811 or D815's cathode.

DISCHARGE POINT

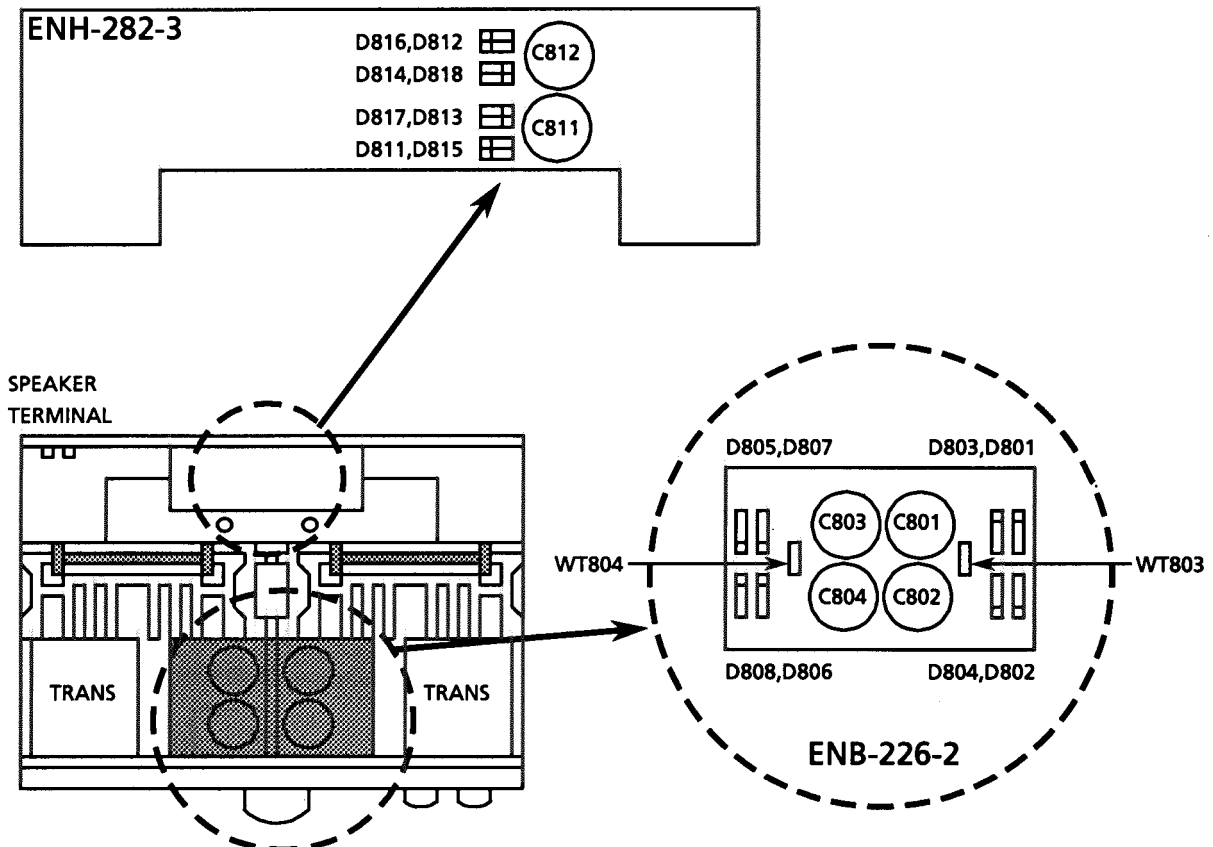

■ NOTICES BEFORE POWERING

1. Check that the condensers below are not short-circuited.

Regulator PCB C811, C812

Increase and decrease AC voltage at nearly 70V by a variac to check the condensers charge and discharge.

Audio section C801, C802, C803, C804

Increase and decrease AC voltage at nearly 70V by a variac to check the condensers charge and discharge correctly. (See "Amp.'s conductive check".)

2. It is required to check DC first in servicing if you doubt that the defect is come from an amp. (Sudden applying of AC230V may cause destruction of the final stage.)

■ SERVICING

1. Discharge the condensers before plugging and unplugging the connectors.
2. Power transistors adopted in this model are controlled in pairs and it is necessary to exchange the kit for the troubleshooting.

(Parts No.)	(Symbol No.)	(Constitute)	(Spot used)
PT216	Q471~Q474	each 2pcs. of 2SC3856LE(PY) 2SA1492LE(PY)	Final output stage of the amp.

3. Put thermal shrinkage tubes on the following transistors in each pairs and shrink them by a drier.
(Q405,Q409), (Q406,Q410), (Q407,Q415), (Q408,Q416)

4. To keep luminance and colour tone of LEDs(D705~D710, D715~D717), they are controlled in the pairs below.

(Parts No.)	(Symbol No.)	(Spot used)
SLR-342YCA47X3	D715~D717	PRESENCE
SLR-342YCTJ7X6	D705~D710	SOURCE SELECTER

■ AFTER SERVICING

1. Check the primary fuse and exchange it with new one if it is deteriorated by excessive current.
2. All adjustments are required.
3. Insulation check between the collector and the heat-sink after exchanging the power transistor.

INSULATION CHECK FOR POWER TRANSISTORS

Connect a probe between a collector and a heat sink(bracket, etc.) to measure the resistance and confirm that it is more than 10MΩ.

[NOTE]

Take care not to touch its emitter or base with pins of the measuring instruments.

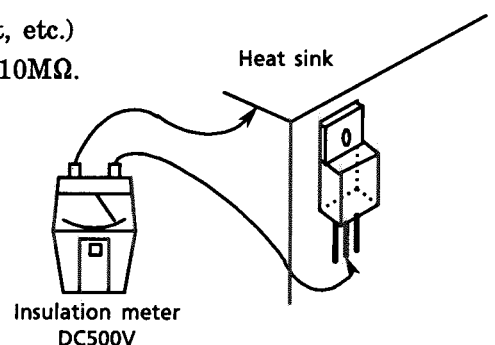

AMPLIFIER'S CONDUCTIVE CHECK

Increase AC voltage gradually with a variac when the power is turned on to check symptom of the amp. (The idling adjustment volume should be rotated completely left.)

■ Power Amp. Section (ENH-282-1,7,9 : LCH ENH-282-2,8,10 : Rch)

1. Disconnect CN441/CN443 (for L-ch check) and CN442/CN444 (for R-ch check) after discharging power supply condensers(C801~C804).
2. Check that the power supply is correct.
(Up and down the power supply vorage between 0V to 70V to check \pm B voltage also ups and downs with the same timing.)
3. Up the power supply voltage gradually while monitoring the idling current.

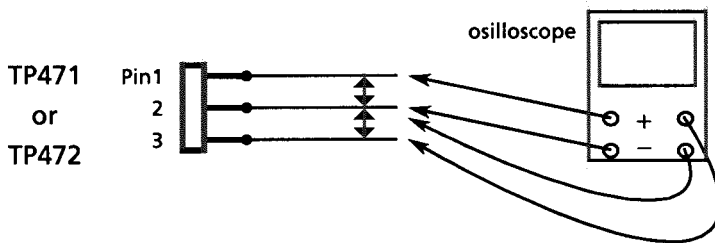

It is necessary to check L-ch and R-ch separately when only one oscilloscope is used for the check.
It is better to disconnect one power supply pin while checking the other pin. (Because the current condition can not be monitored.)

* The idling will be kept "0" if it is correct.

■ Pre-Drive & Volume PCB. (ENH-282-4)

1. Disconnect connectors CN441/CN443/CN971 (for L-ch check) and CN442/CN444/CN972 (for R-ch) after discharging C801/C802/C803/C804. (not to affect the power amp. section badly)
2. Connect FW441(FW442)'s pin1 and FW445's pin1(pin5) and also FW443(FW444)'s pin2 and FW445's pin1(pin5) through each 10k Ω . (Feedback)
3. Check the voltage at transistor's pin. Increase AC power supply voltage gradually and measure voltage of the transistor's pin(collector/emitter/base) to confirm its normal current.
4. Input signal is added to CN311 to check signal on FW441/FW443(FW442/FW444) when the circuit is normal after increasing voltage up to 230V.
5. Q405/Q409, Q407/Q415, Q406/Q410 and Q408/Q416 are thermally coupled.
Couple each of them with the specified tube.

■ Regulator PCB. (ENH-282-3)

1. Check the power voltage. The correct voltage will not be output unless the power is ON. Turn the power ON for the check.

Some working points which affect sound Quality

* The followings show some working points which affect sound Quality in servicing(after disassembling and replacing parts and reassembling)

■ Insulation check for the bracket which has bushings

- 1) Take care not to cut bushings by top of screws, etc. when removing and setting brackets, etc. (See the right figure.)
- 2) Set a tester resistor mode and 1 range to check that the bracket and top cover, bottom plate and rear panel is not conductive. (The bottom plate and the bracket should be insulated.) This should be checked at points of non-painted bracket or at screw holes.
- 3) Follow the removing procedure (page 2-15) to fix the screws or the bushing is damaged and it can not be insulated.

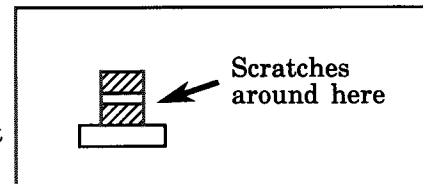

■ Transistor's torque on the heat sink and screw's torque for the transformer and the power supply PCB.

- 1) Torque of transistors which are on the heat sink. → 78.4N
- 2) Torque of screws which fasten transformers and power supply PCB. → Approx. 98~117.6N

■ Torque to fasten the bolt through the heat sink

- 1) The bolt should be strongly fastened in manual but the washer should not be lodged in the heatsink.

■ Points which have washers

- 1) Do not miss washers to put them again.

■ Assembling front and top covers and side panels

- 1) See the disassembling procedure. (page 2-21)

■ Alignment of idling current and L/R difference

- 1) See the alignment procedure. (page 2-25)

■ DC offset value

- 1) See the alignment procedure. (page 2-25)

■ Hfe rank of transistors, same L/R

- 1) Except for the power transistor PT216 described in Notices for servicing (page 2-4), also other transistors which have same rank for L/R should be used.

■ Putting resistors

- 1) Put R351~R354, R973 and R974(ERD127J) on the PCB. so that the color code can be found from the board's soldered side.

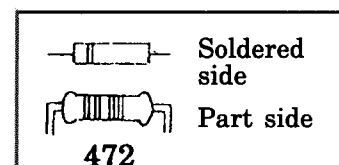

■ Formation and twisting transistors' secondary wire and $\pm B$ output wire.

- 1) See Wiring (page 2-9).

■ Others and necessary working in servicing

- 1) Transistors of Q455, Q456, Q471~Q474 to put on the heatsink have short leads.
Do not make stress on the PCB(ENH-282-1, -2).

This angle should be 90°. Forcefully fastening causes poor Quality sound.

This PCB. should be horizontal which is parallel to the heat sink.

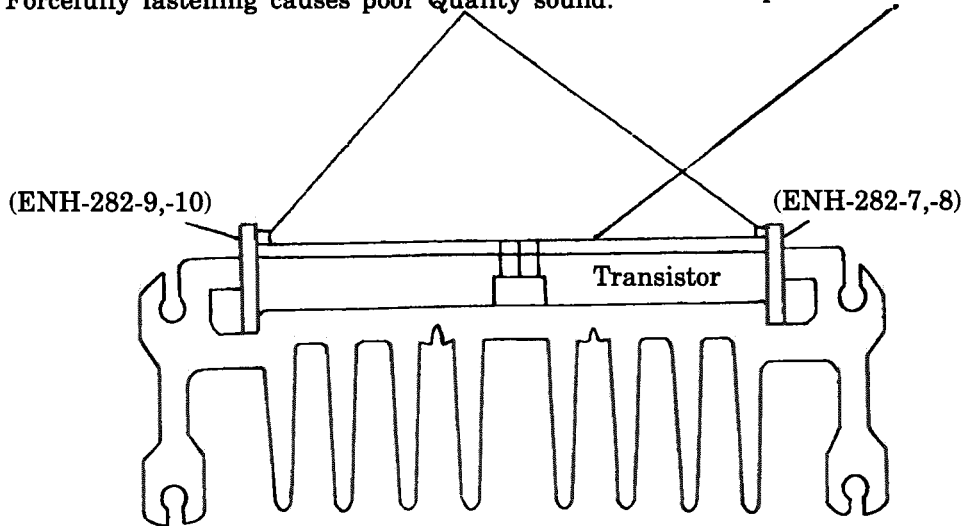

- 2) Put spacers on the spots which are marked with ● on both sides of the PCB. (See the PCB. diagram for working.)
- 3) Put thermal shrinkage tubes on the following transistors in pair and shrink them by a hair drier, etc.
(Q405,Q409), (Q406,Q410), (Q407,Q415), (Q408,Q416)

Tube
QXTFA00-010 ×4

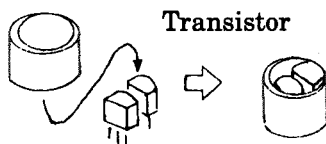

- 4) Apply glue(#550) on C811, C812 and C801~C804. (See the PCB. diagram for working.)
Take care not to apply the glue on their wrapping terminals.
- 5) Put the shield tape on C811, C812 and C861 to fix it firmly. (See the PCB. diagram for working.)
Note: Put gloves for safety.
Once-used-shield tape is easy to be detached. Please replace the shield tape together with C811, C812 and C861 in case of its replacement. (Shield tape P/N: E75303-003,E75303-004)
- 6) Diodes of D705~D710 and D715~D717 need replacement in pairs for replacing LED because variation will occur if each pairs do not have same rank.
The followings show those pairs.

(Parts No.)	(Symbol No.)
SLR-342YCA47X3	D715~D717 for PRESENCE
SLR-342YCTE7X6	D705~D710 for SOURCE SELECTOR

WIRING

■ Wiring for the power supply PCB.

Form this wire so that it tracks the coil and the relay.

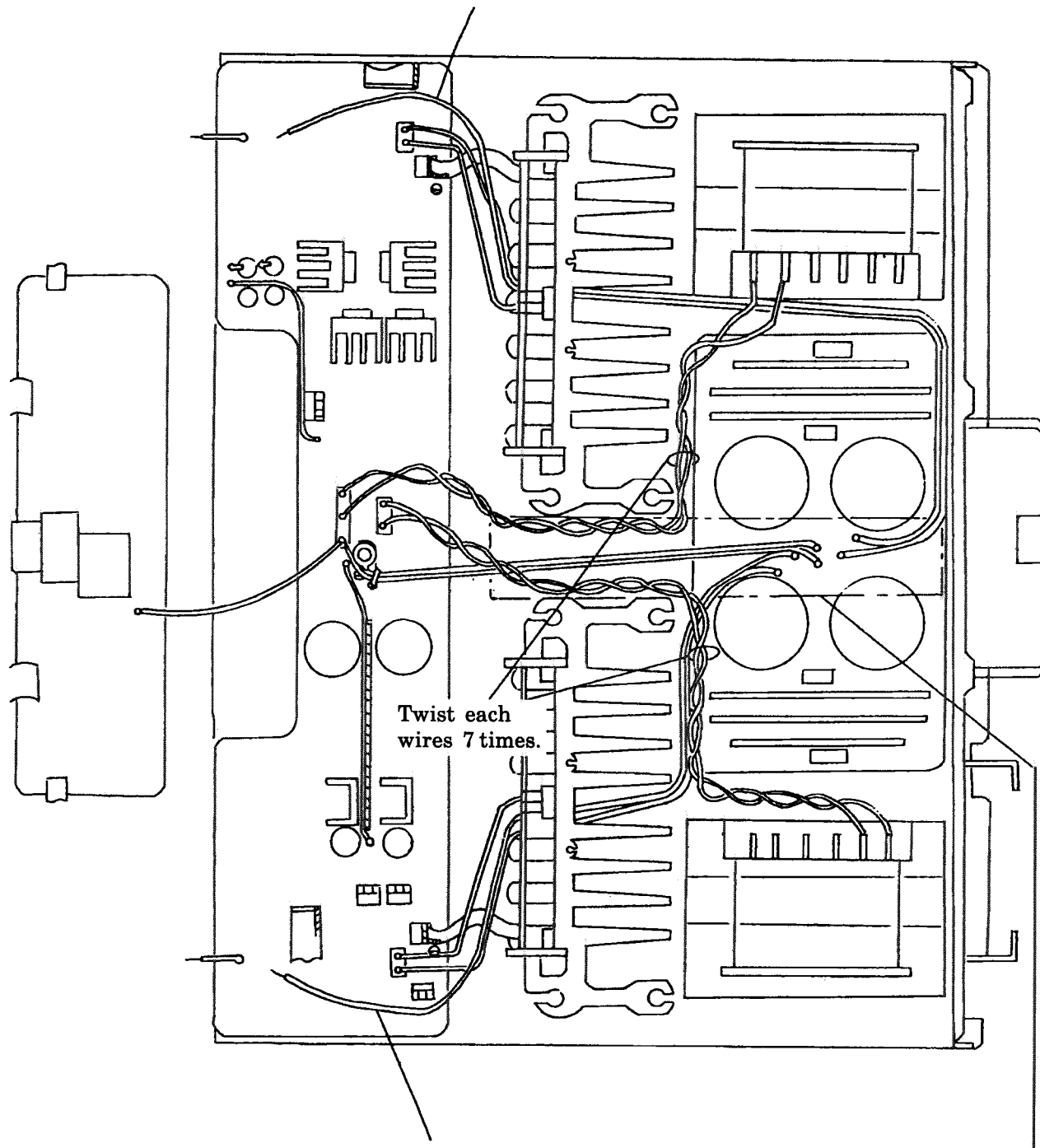

Form this wire so that it tracks the coil and relay.

Wires surrounded by this area should not be floated but sunk.

■ Wiring diagram for front side

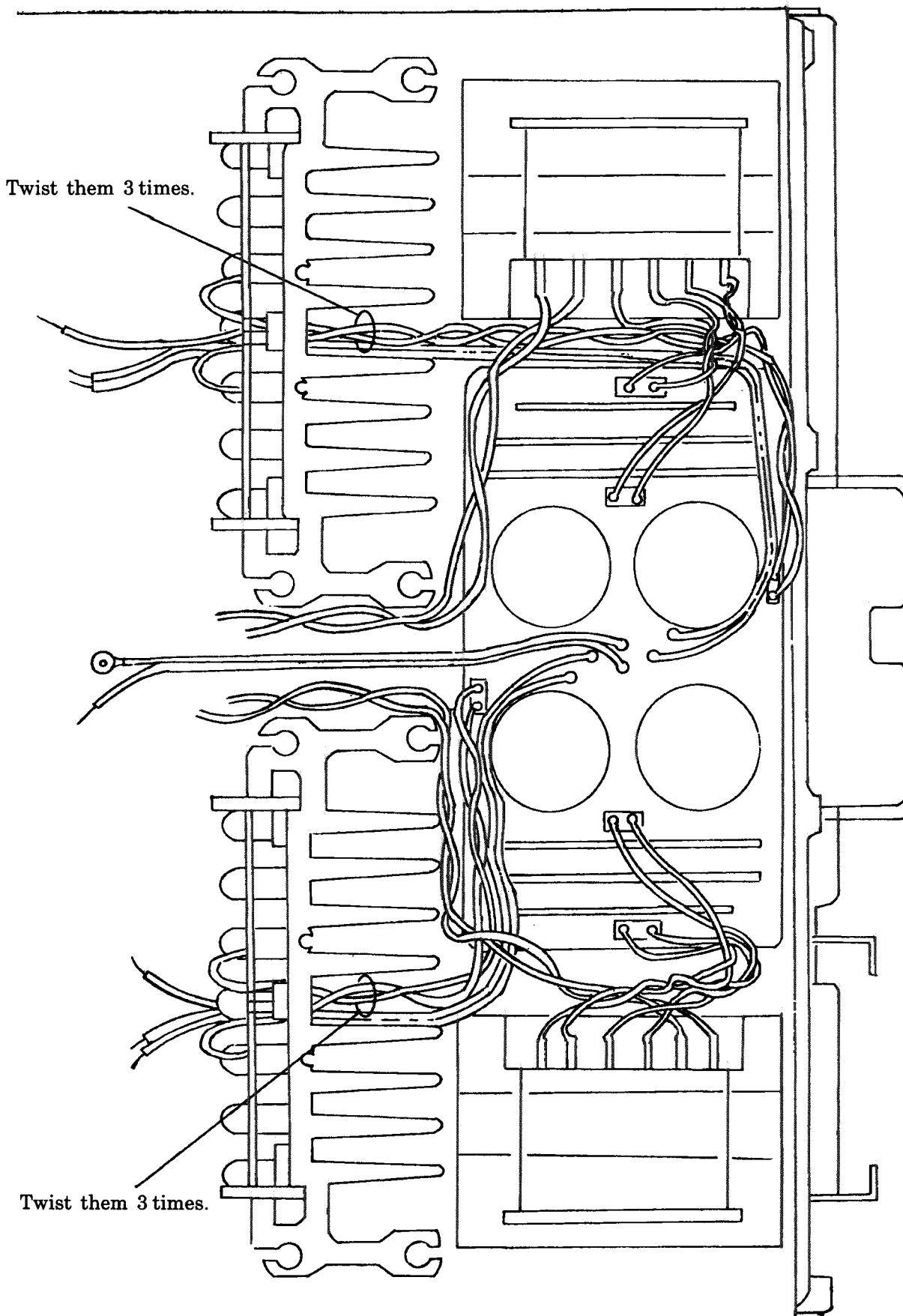

■ Wire formation for transformer(I)

Form both right and left wires. (See the below.)

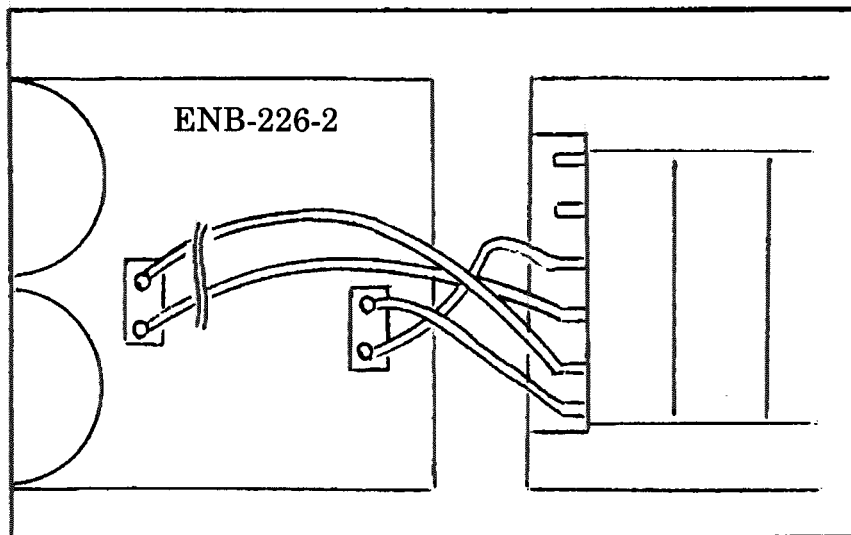

1. Do not twist wires for transformer to wrap with ENB-226-2.

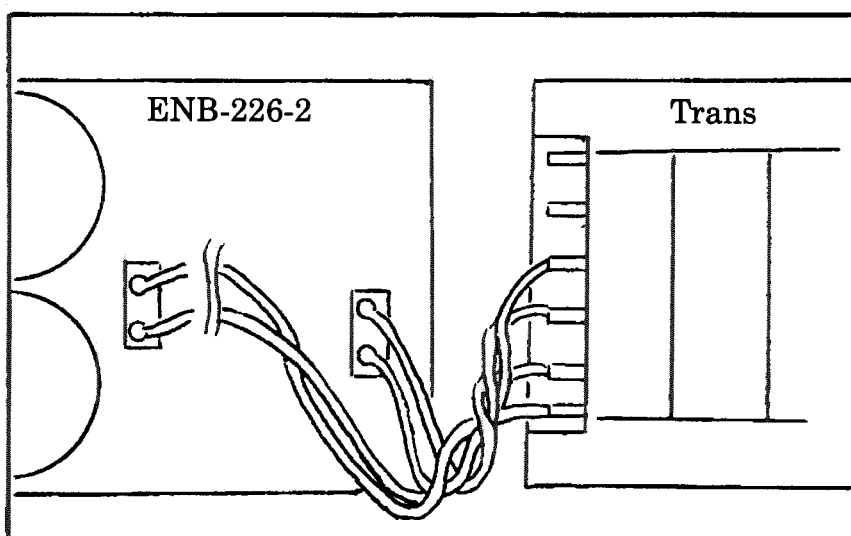

2. Twist 4 wires altogether once.

■ Wire formation for transformer (II)

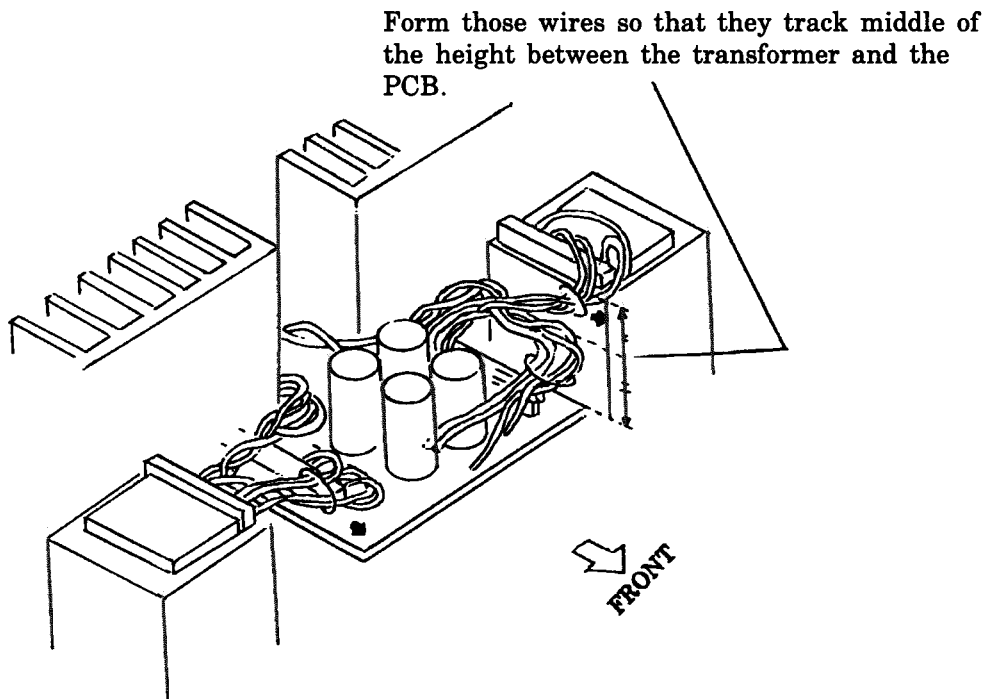

■ Wiring for primary power supply

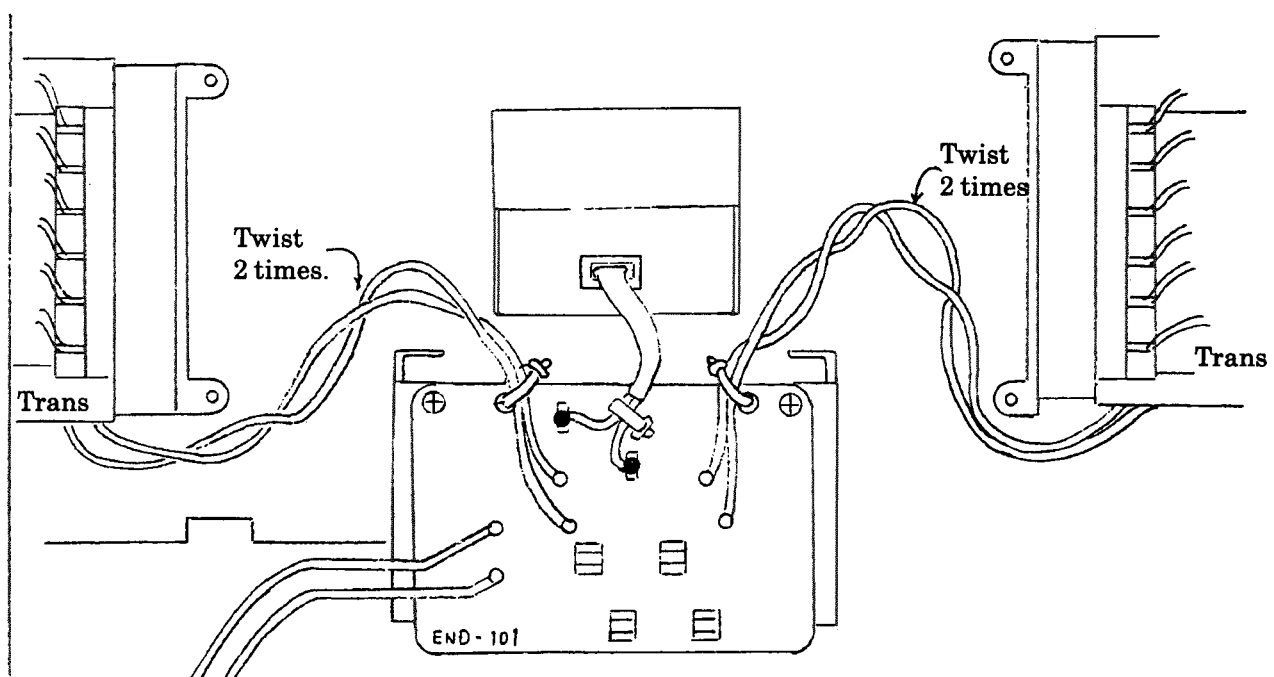

■ Wiring for Rectification PCB.

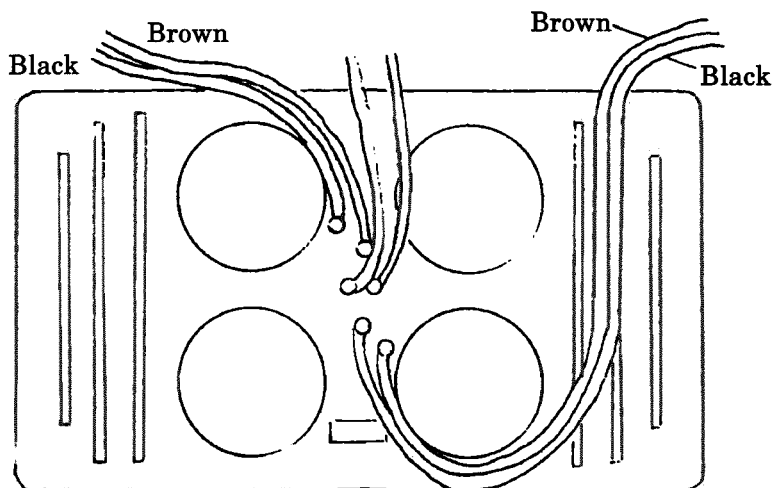

ENB-226-2

↓
FRONT

■ Wiring for heat sink ass'y

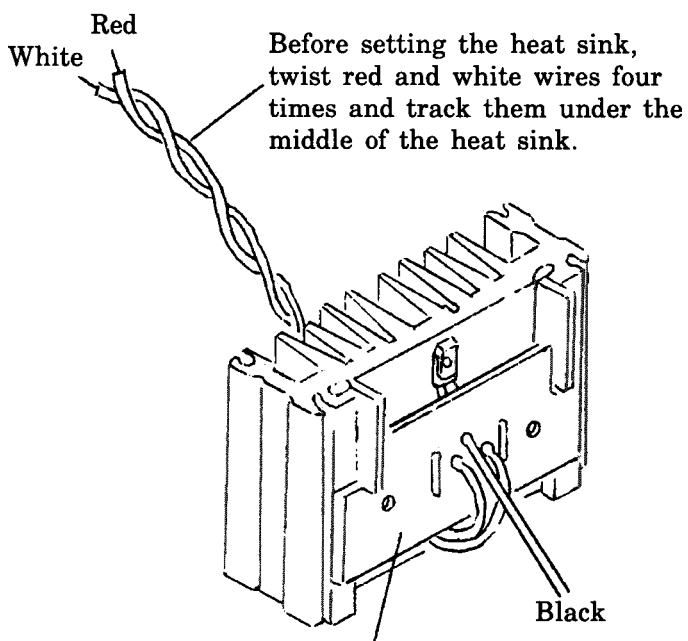

- Heat sink Ass'y(R)
- ENH-282-2
- Heat sink Ass'y(L)
- ENH-282-1

■ Wiring for heat sink PCB.

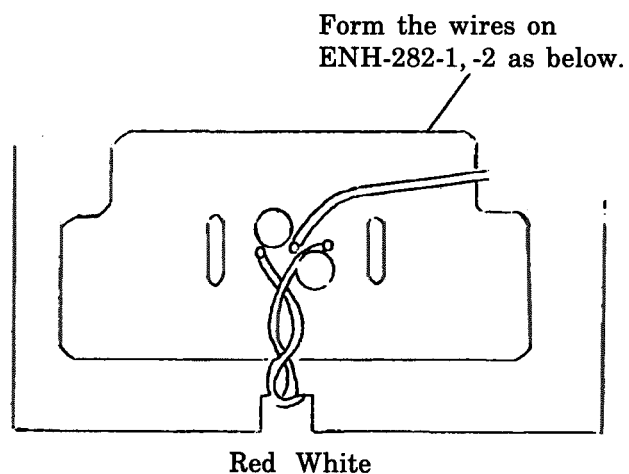

※ Before setting the heat sink ass'y, GND wire(black) and speaker wire(brown) from the rectification PCB.(ENB-226-2) and $\pm B$ wire(red/white) from the heat sink PCB.(ENH-282-1, -2) should track under the heat sink.

AX-SD1GD

Disassembling diagram for workings

Shows bushing.

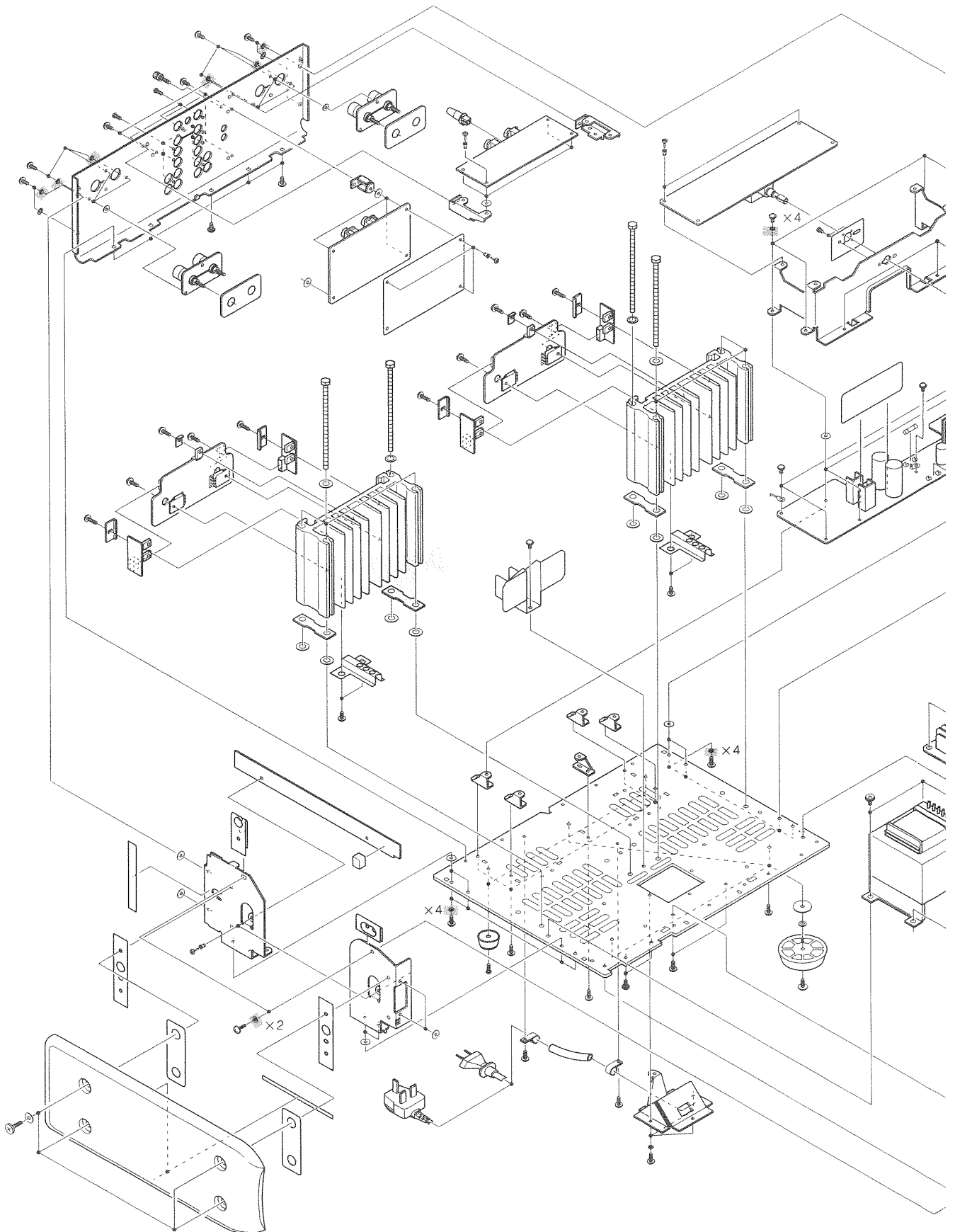

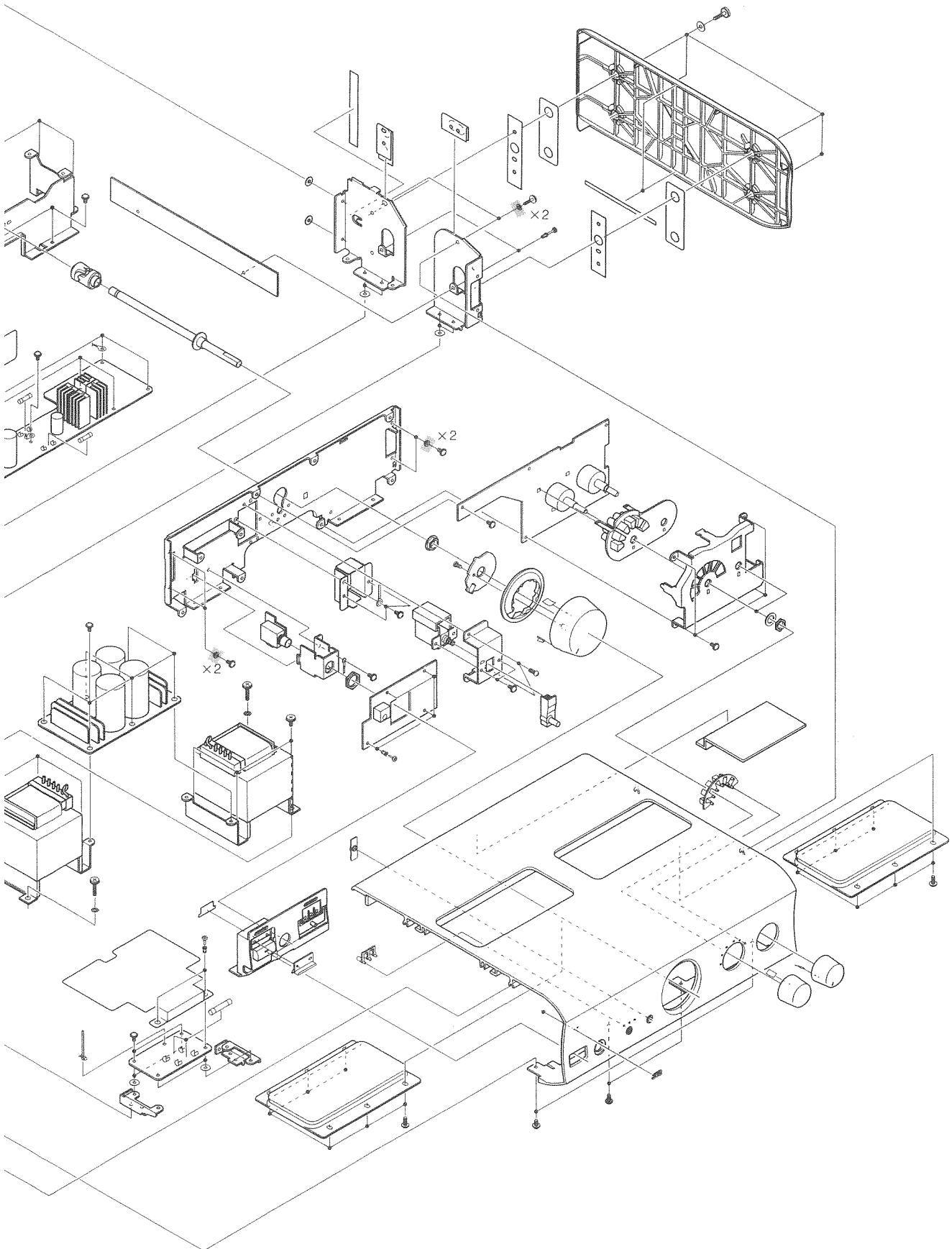

PCB. diagram for workings

■ ENH-282 (parts side)

Put 16spacers(E73967-016)on spots ma
Do not cover holes on the PCB.

Apply glue(#550) on C811 and C812(m

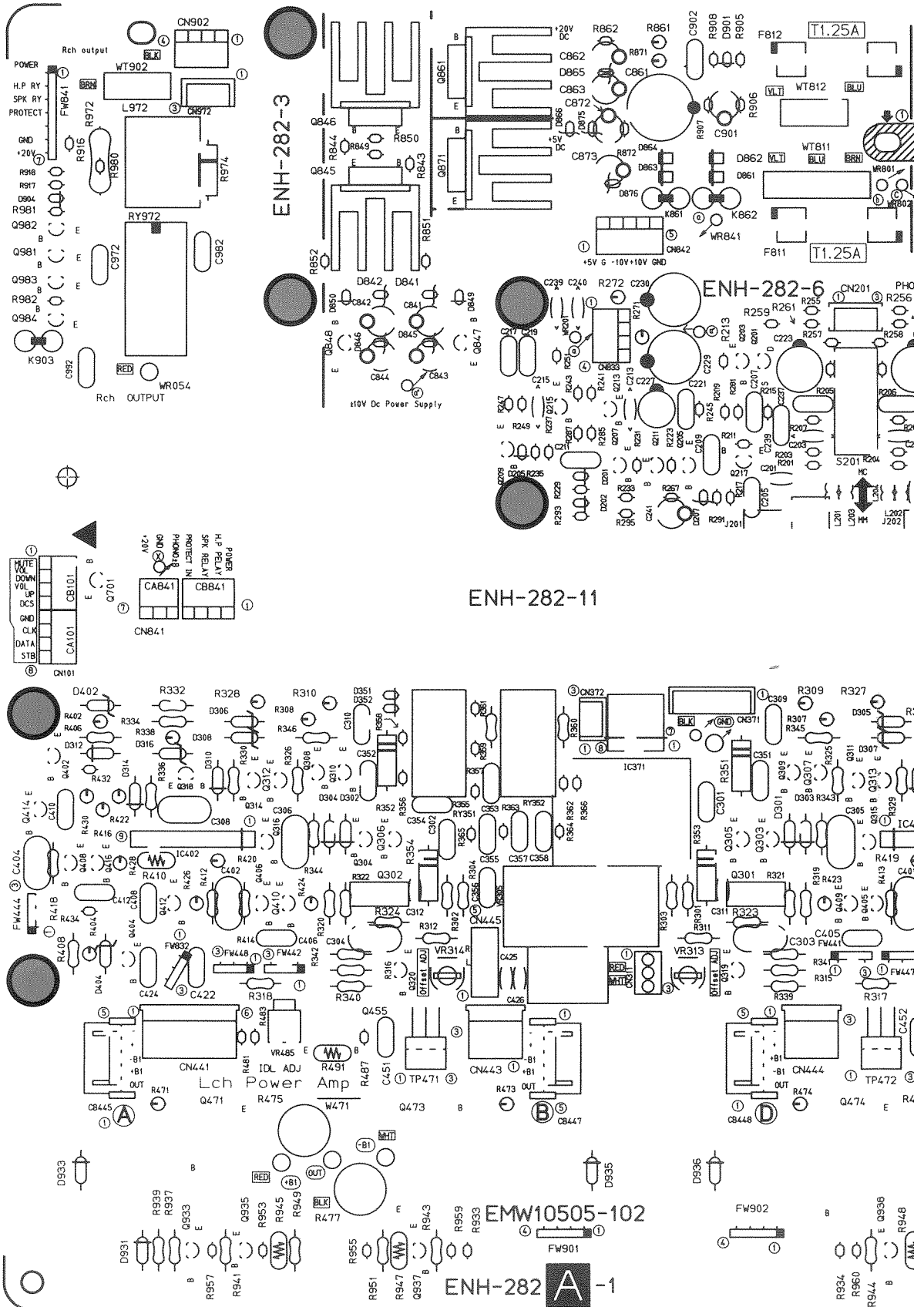

s marked with ●.

Put the shield tape on C816 to fix it firmly.

Some working points which affect sound Quality.(See page2-8 5)

812(marked with ●).

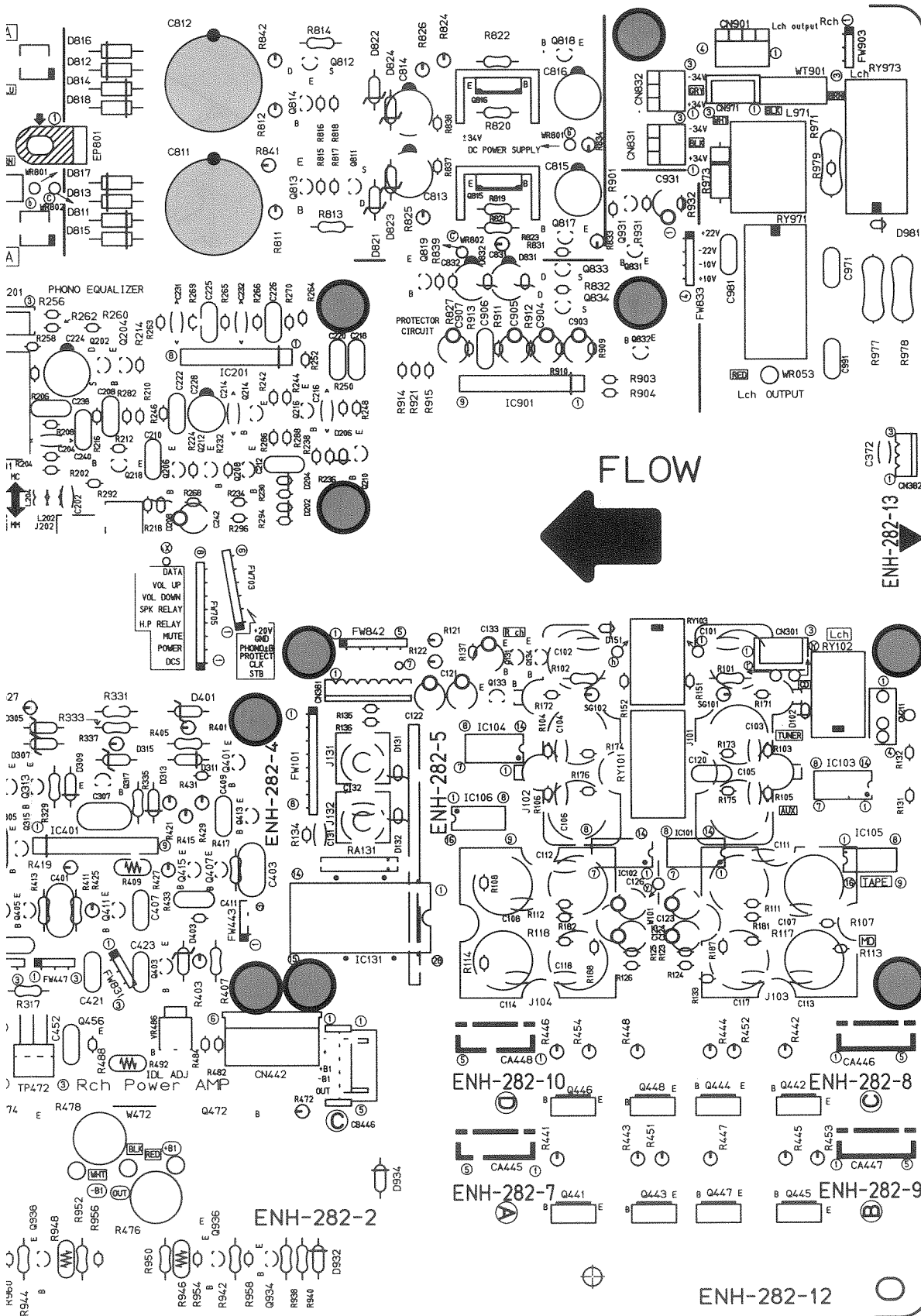

■ ENH-282 (soldered side)

Put 9spacers(E73967-016)on spots marked with ●.
Do not cover holes on the PCB.

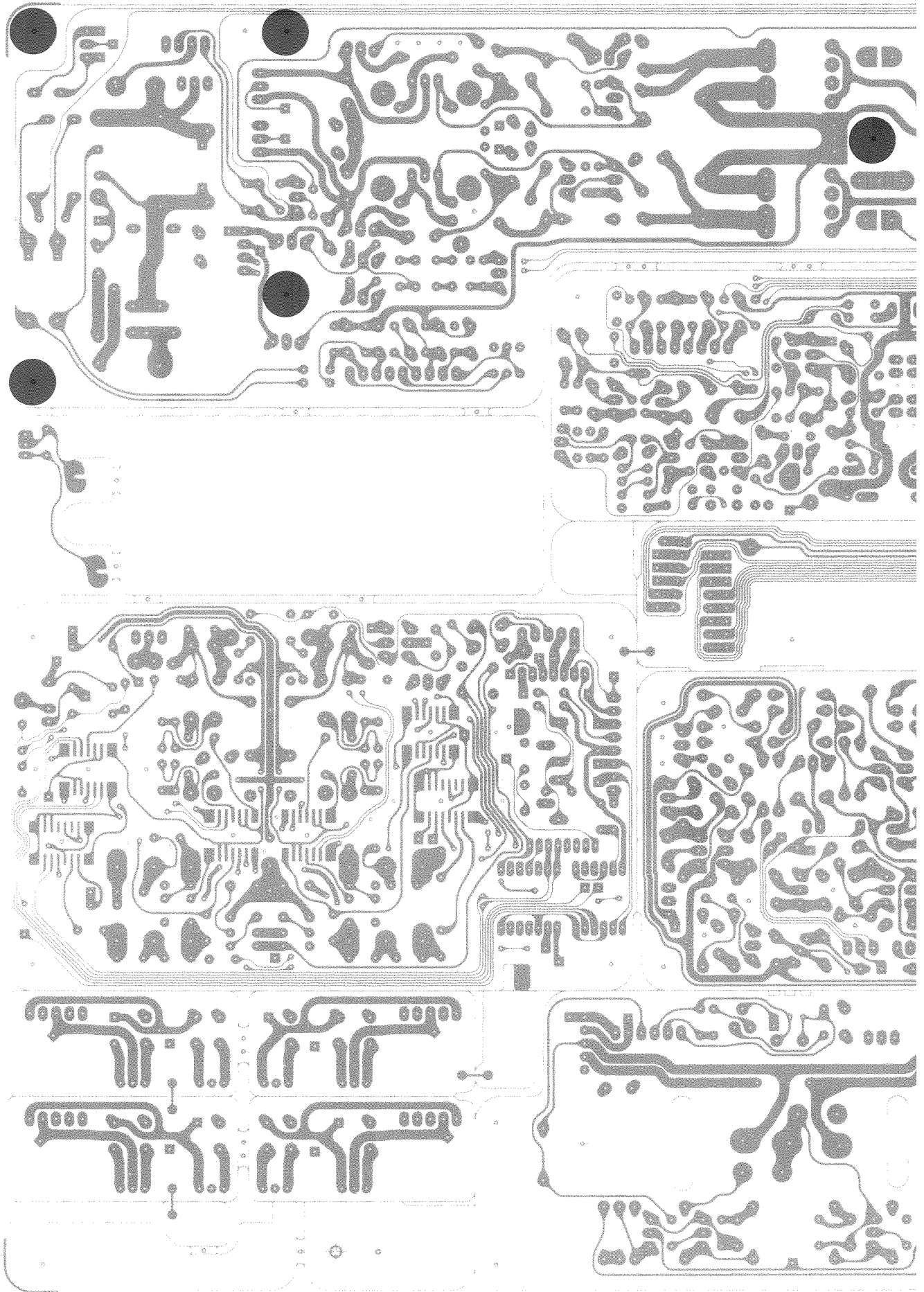

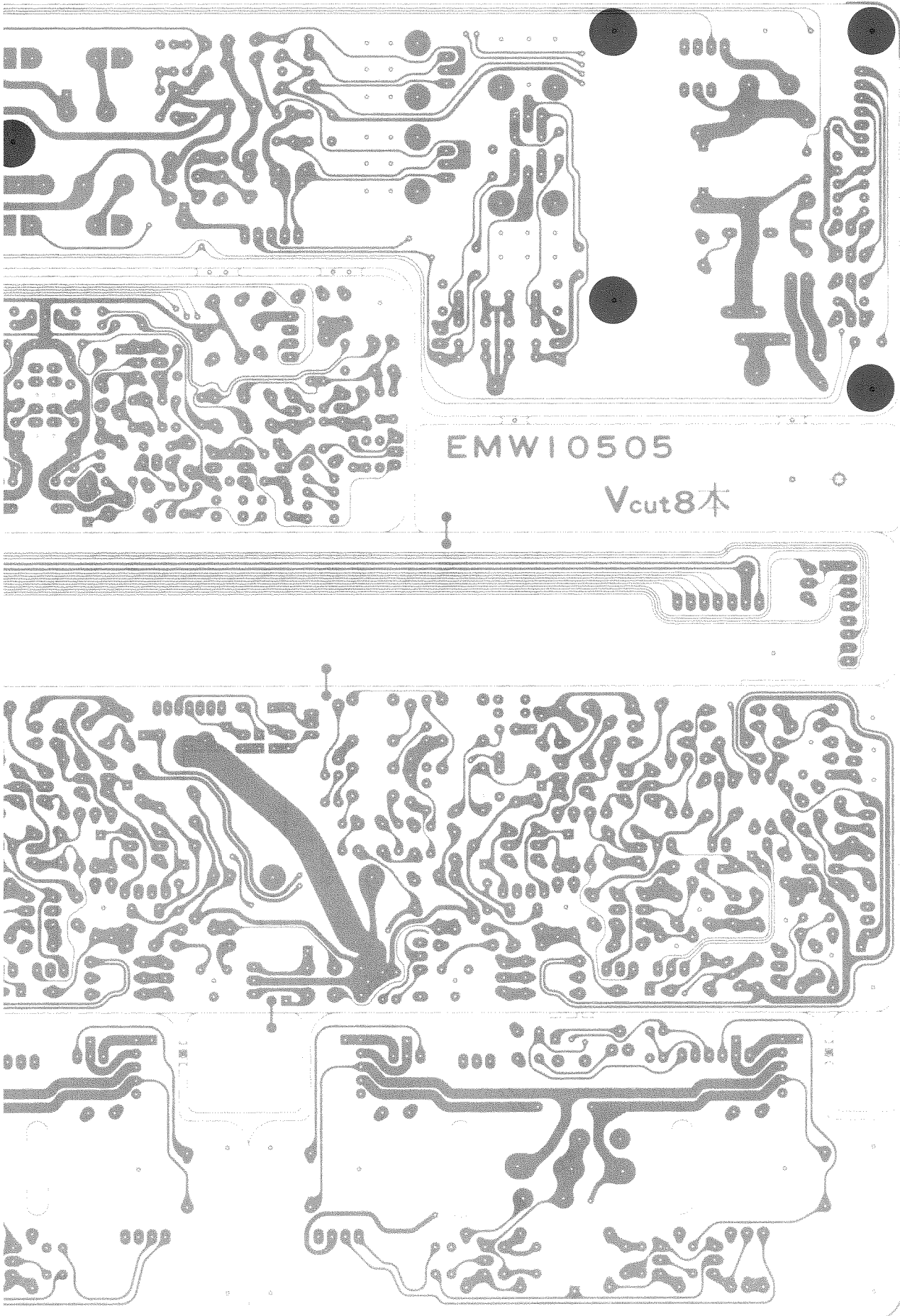

■ ENB-226 (parts side)

Apply glue(#550) on C801~C804
 (marked with ●)
 Take care not to apply the glue
 on their wrapping terminals.

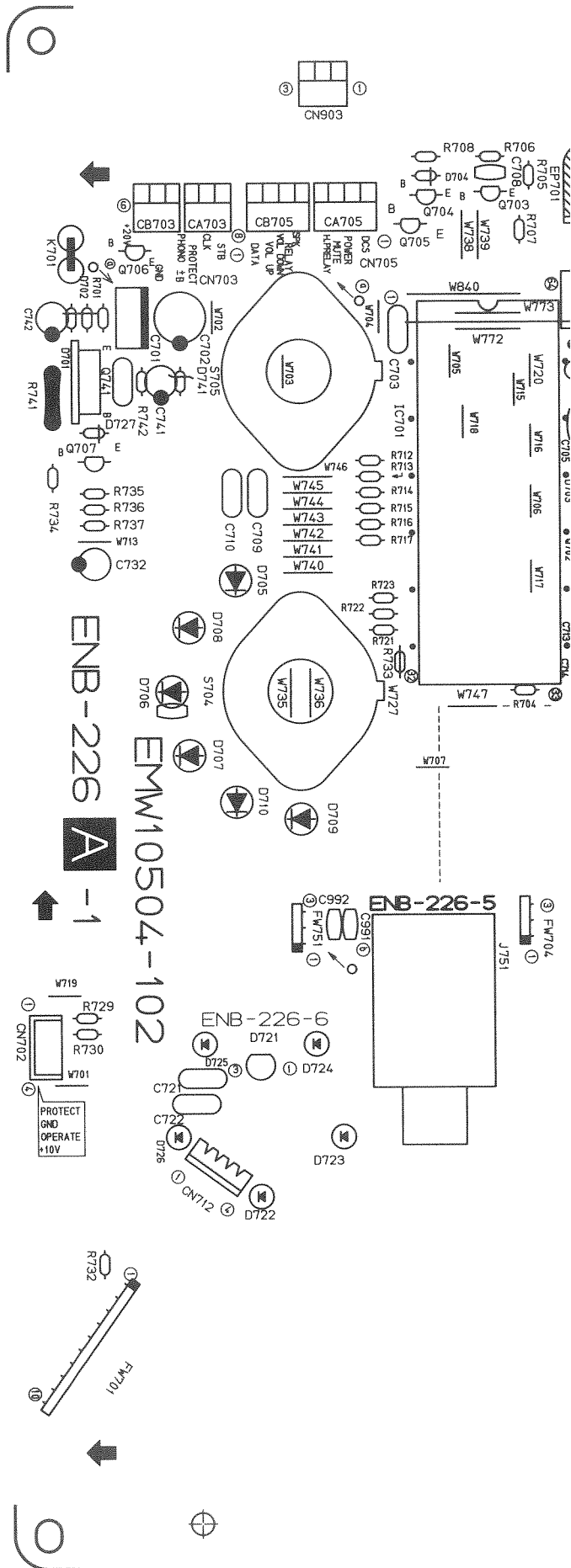

ENB-226-17

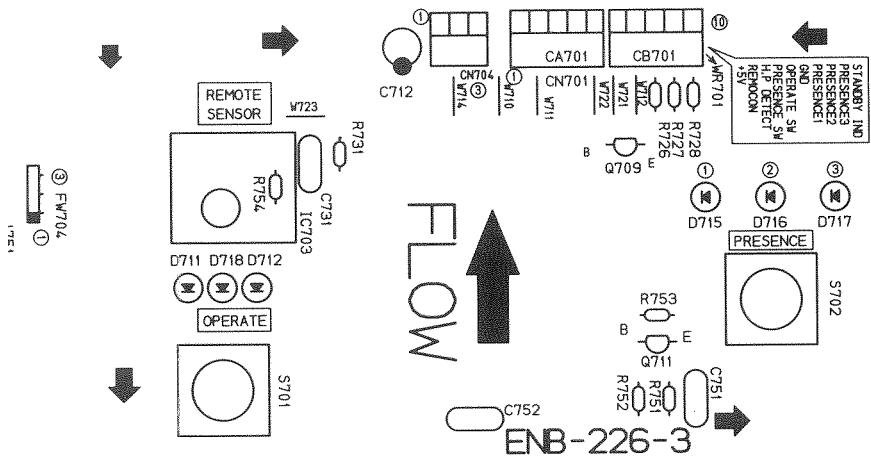
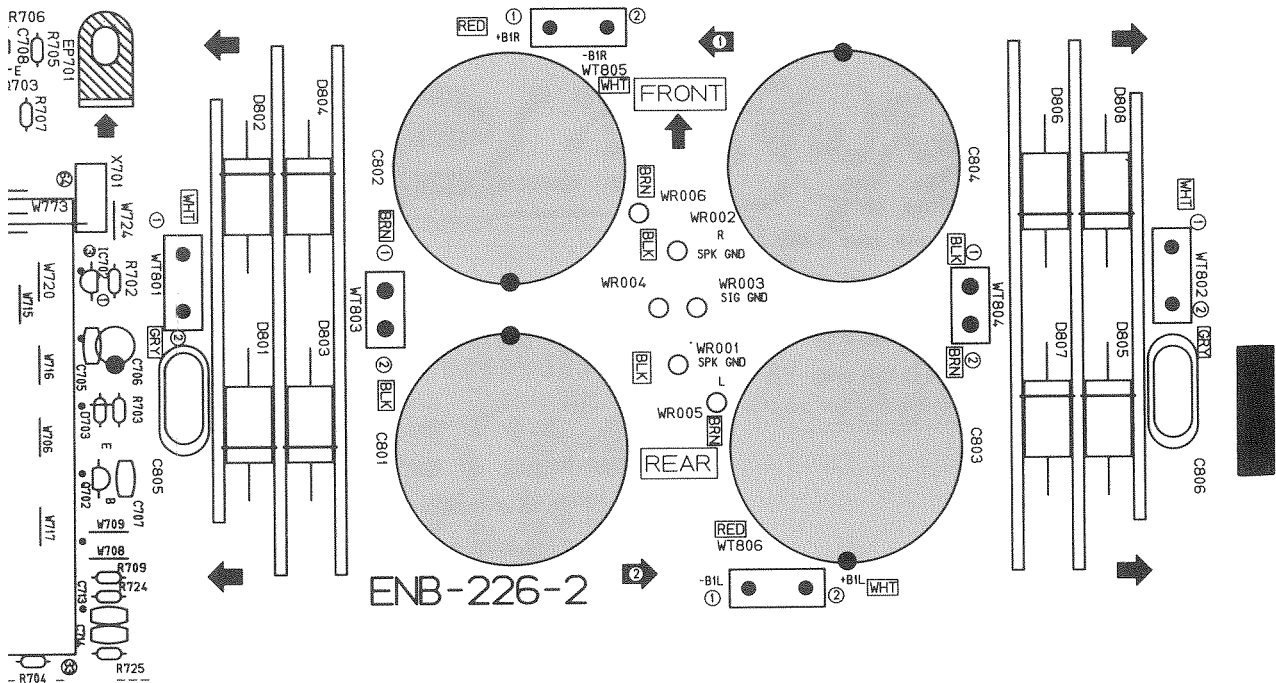

■ ENB-226 (soldered side)

Put 6 spacers (E73967-016) on spots marked with ●.
Do not cover holes on the PCB.

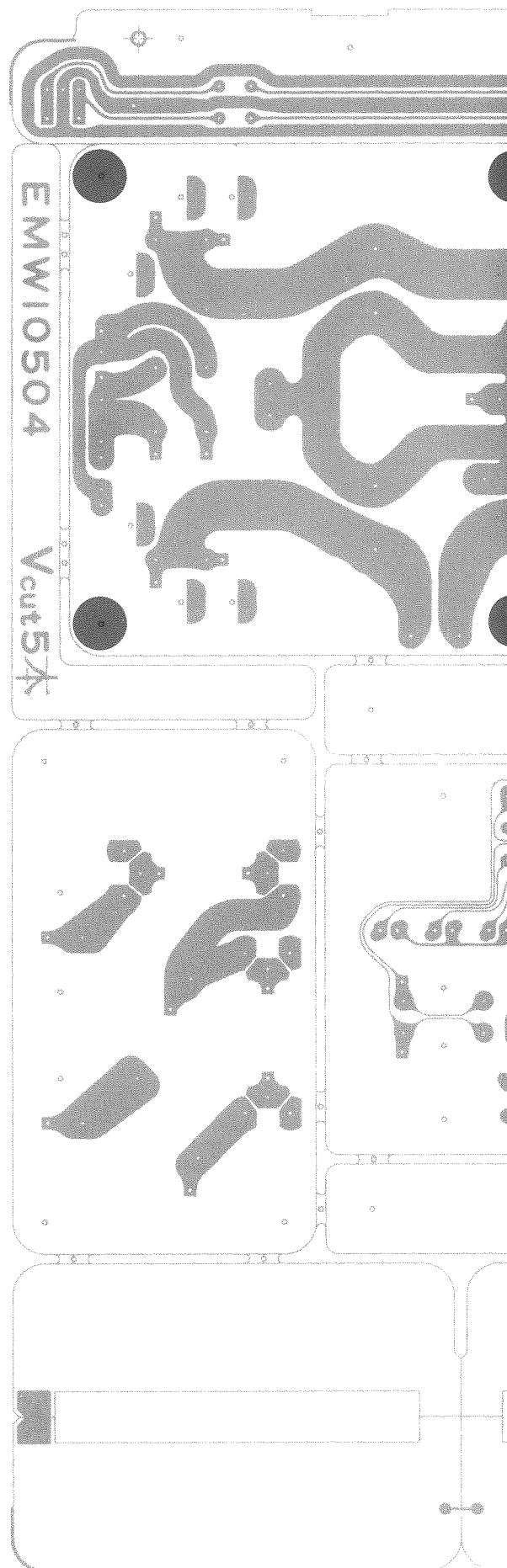

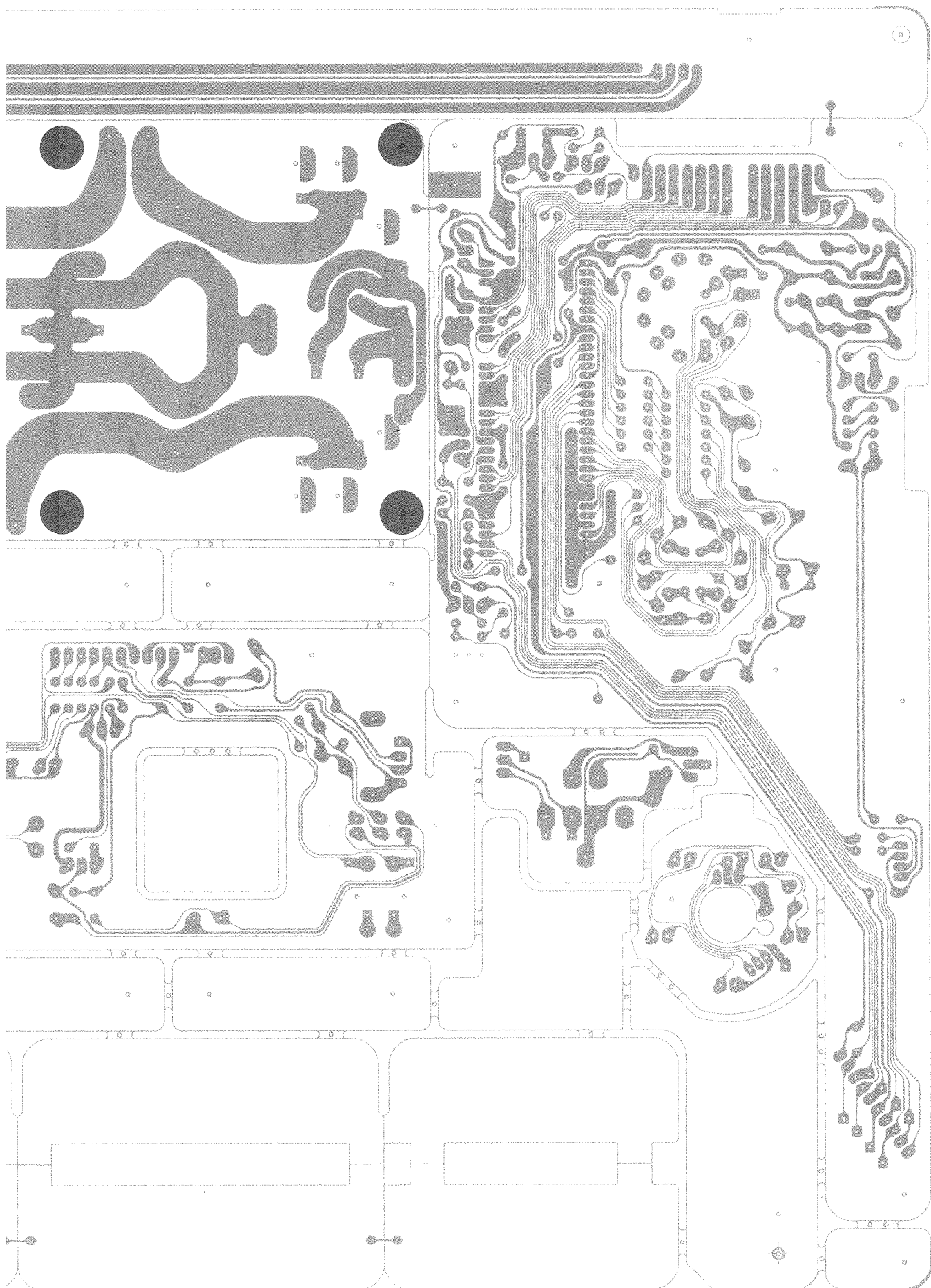

Block Diagram

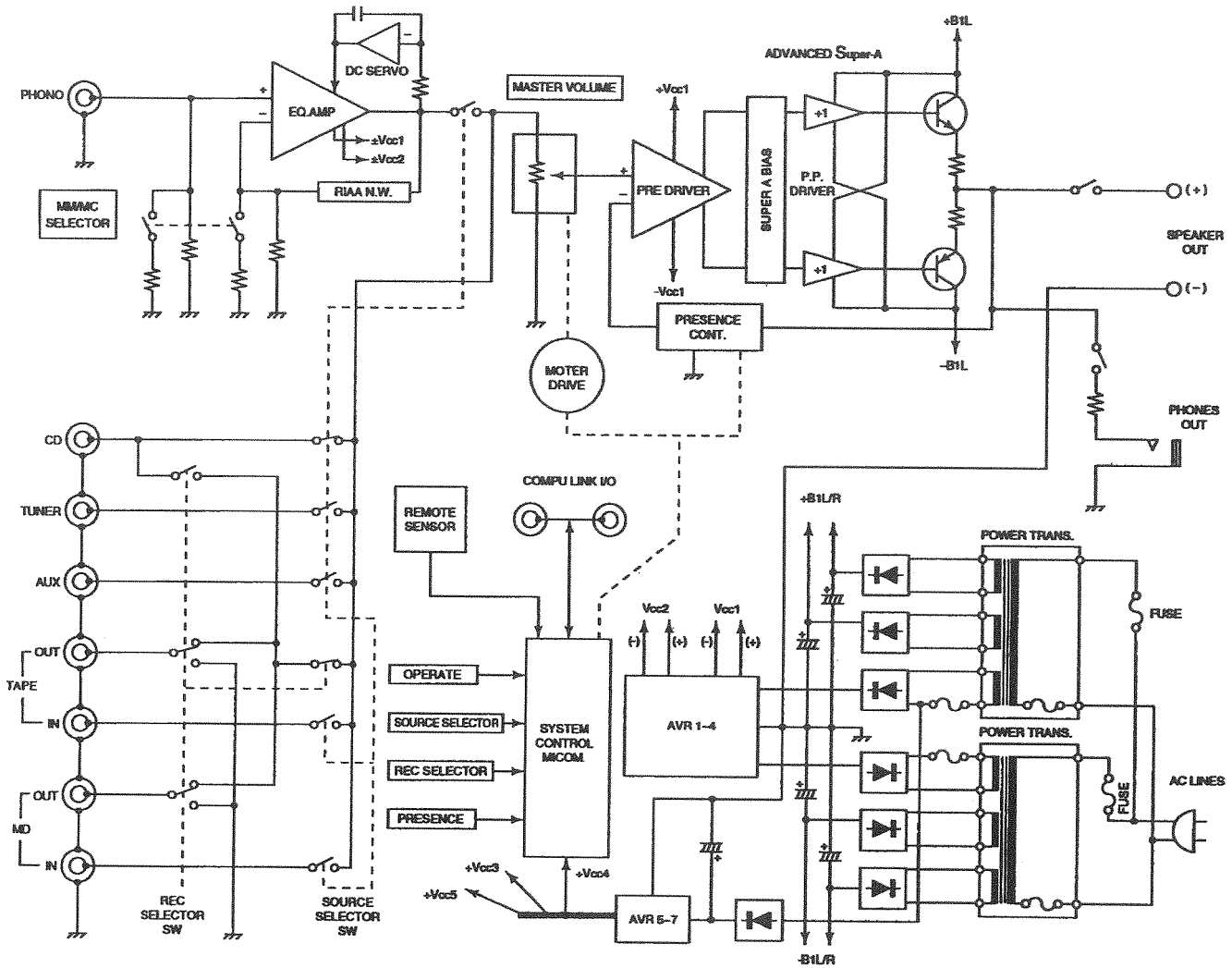

■ END-101 (soldered side)

Put 4 spacers (E73967-016) on spots marked with ●.
Do not cover holes on the PCB.

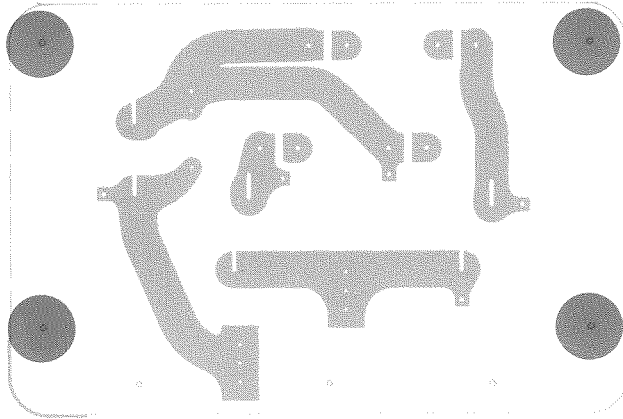

Disassembly Procedures

1. Side Panel removal

- 1) Remove 8 screws (A) fastening both the side panels. (The curved side shows front of the side panel.)
- 2) Disassemble the side panels.

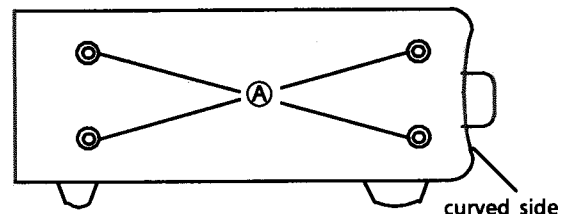

Fig-1. Side

2. Side panel assembly

- 1) Set the edge of the side panels with the one for the front and position it lower to adjust the side panels top with the one for the front.
- 2) Tighten screws for the bottom in advance.

3. Front panel removal

*Take care not to tear or cut spacers attached on the side bracket. Replacement with new one will be needed if it is torn or cut.

- 1) Disassemble the side panels.
 - 2) Remove 4 screws (B) fastening both sides of the front panel.
 - 3) Remove 4 screws (C) fastening under the front panel.
 - 4) Pull the front panel forward to disassemble it.
- *Clearance between the volume knob and the cover is narrow. Cover the knob with paper, etc. before the removal to prevent the knob from being scratched.

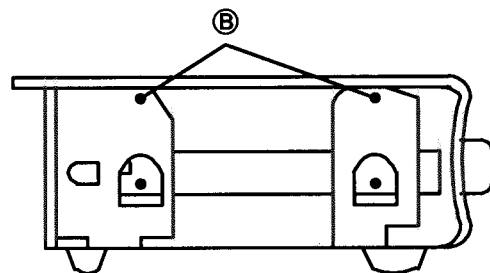

Fig-2. Left side (Without side panel)

4. Front panel assembly

- 1) Also, cover the knob not to be scratched.
- 2) Fasten screws for the side after fastening the ones for the bottom.

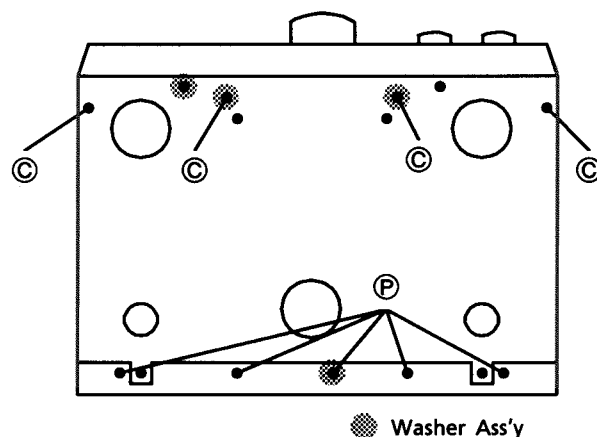

Fig-3. Bottom side

5. μ -COM PCB (ENB-226-1) removal

- 1) Disassemble the side panels and front panel.
- 2) Disconnect the connectors (CN701,CN702,CN703,CN705).
- 3) Remove 5 screws ① fastening the μ -com PCB to remove it.

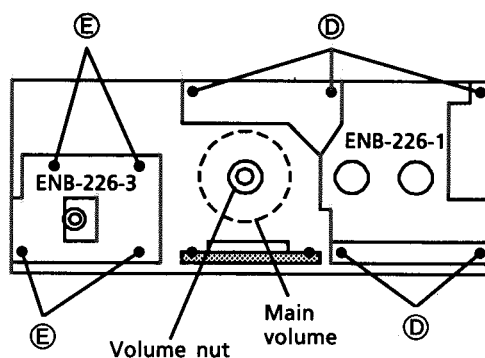

Fig-4. Front side (Without Front Panel)

6. Remote control sensor PCB (ENB-226-3) removal

- 1) Disassemble the side panels and front panel.
- 2) Disconnect the connectors (CN701,CN704).
- 3) Remove 4 plastic rivets ⑤ fastening the remote control sensor PCB to remove it.

7. Commutation PCB (ENB-226-2) removal

- 1) Disassemble the side panels and front panel.
- 2) Disconnect the connector (CN702).
- 3) Pull out the master volume knob.
- 4) Remove nut fastening master volume shaft.
- 5) Pull out the master volume shaft from joint ass'y.
- 6) Remove 6 screws ③ fastening the commutation PCB to remove it. (Remove each wires if necessary.)

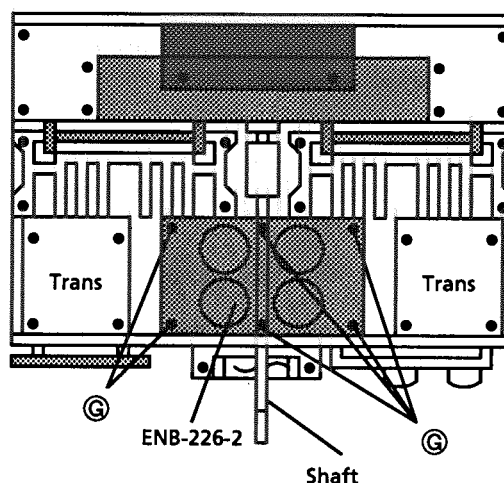

Fig-5. Upper side

8. Power supply PCB (END-101-1) removal

- 1) Remove the commutation PCB.
- 2) Remove 2 plastic rivets ④ fastening the shield plate to remove it.
- 3) Remove 2 screws ① fastening the power supply PCB to remove it.

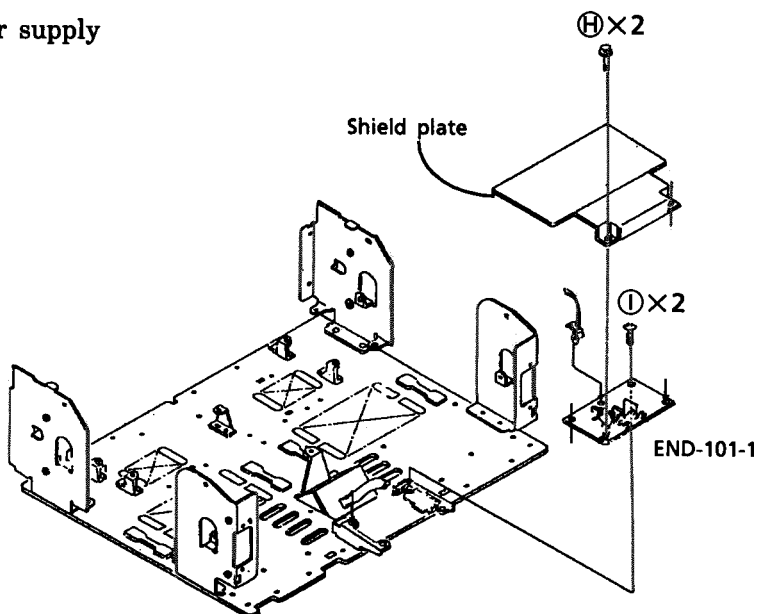

Fig-6. Upper side

9. Heat sink assembly (Left side) removal

- 1) Disassemble the front panel.
- 2) Disconnect the connectors (CN441,CN443,CN901).
- 3) Remove 4 screws ① and ② fastening the heat sink ass'y to remove it.

10. Power amp PCB (ENH-282-1) removal

- 1) Disassemble the heat sink ass'y.
- 2) Remove 9 screws ③ fastening the power amp PCB to remove it.
(Unsolder wires connected with PCB., if necessary.)

11. Phono EQ PCB (ENH-282-6) removal

- 1) Disassemble the front panel.
- 2) Remove 2 plastic rivets ④ fastening the Phono EQ PCB.
- 3) Remove 2 screws ⑤ which fasten rear side of the PCB.
- 4) Disconnect the connectors (CN833,CN201).
- 5) Remove the phono EQ PCB.
(Take care not to scratch S201's knob.)

12. Rear panel assembly removal

- 1) Disassemble the front panel.
- 2) Remove 4 screws ⑥ which fasten back of the rear panel ass'y and 5 screws ⑦ (see-Fig-3.) fastening its bottom.
- 3) Disassemble the rear panel ass'y. (Disconnect each connector if necessary.)

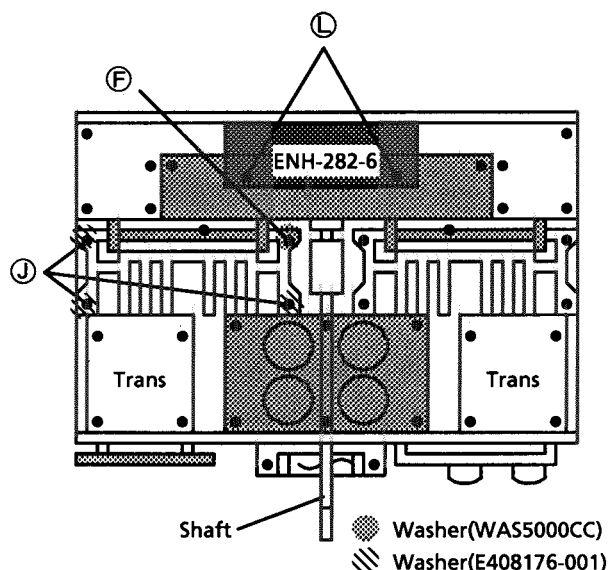

Fig-7. Upper side

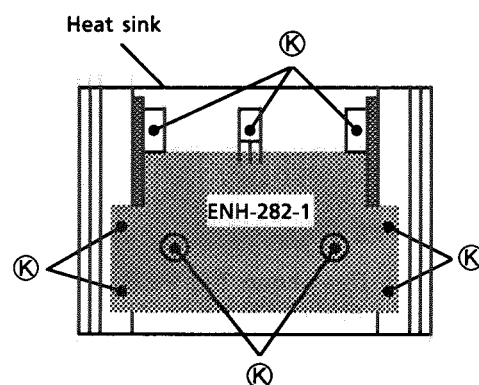

Fig-8. Heat sink ass'y

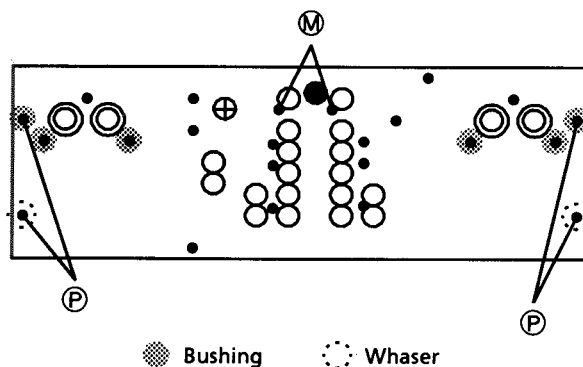

Fig-9 Rear side

13. Pre-Drive PCB (ENH-282-4) removal

- 1) Disassemble the rear panel ass'y.
- 2) Remove 2 plastic rivets ① fastening the pre-drive PCB.
- 3) Pull out the master volume knob.
- 4) Remove nut fastening master volume shaft.
- 5) Pull out the master volume shaft from joint ass'y.
- 6) Remove the joint ass'y.
- 4) Disconnect the connectors (CN441,CN442,CN443,CN444,CN447,CN448, CN971,CN972,CN831,CN832).
The PCB. can be open to be handled.
Unsolder other wires and connectors if necessary.

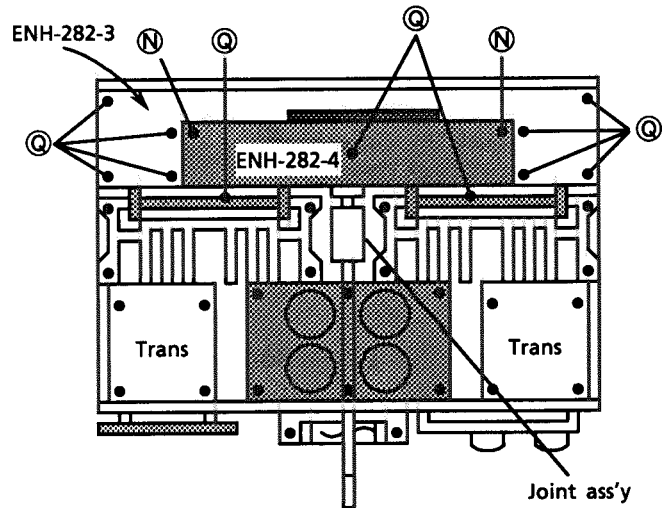

Fig-10. Upper side

14. Regulator PCB (ENH-282-3) removal

- 1) Remove the pre-drive PCB.
 - 2) Remove 11 screws ③ fastening the volume bracket and regulator PCB to remove its.
- (Unsolder other wires and connectors which are connected with the PCB. if necessary.)

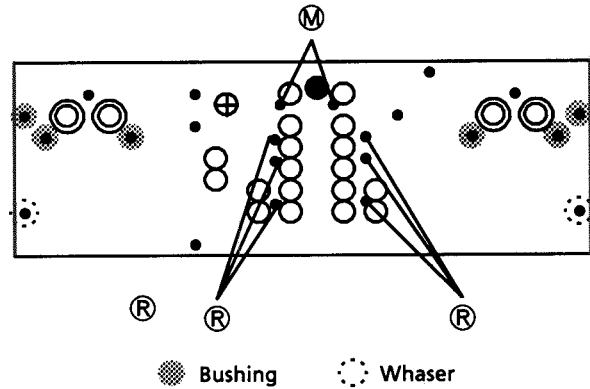

Fig-11 Rear side

15. Input PCB (ENH-282-5) removal

- 1) Remove the phono EQ PCB.
- 2) Disassemble the rear panel ass'y.
- 3) Disconnect the connectors (CN842,CN381,CN101,CN301).
- 4) Remove 6 screws ⑥ fastening the input PCB.
- 5) Remove 3 plastic rivets ⑦ fastening the shield plate and input PCB to remove its.

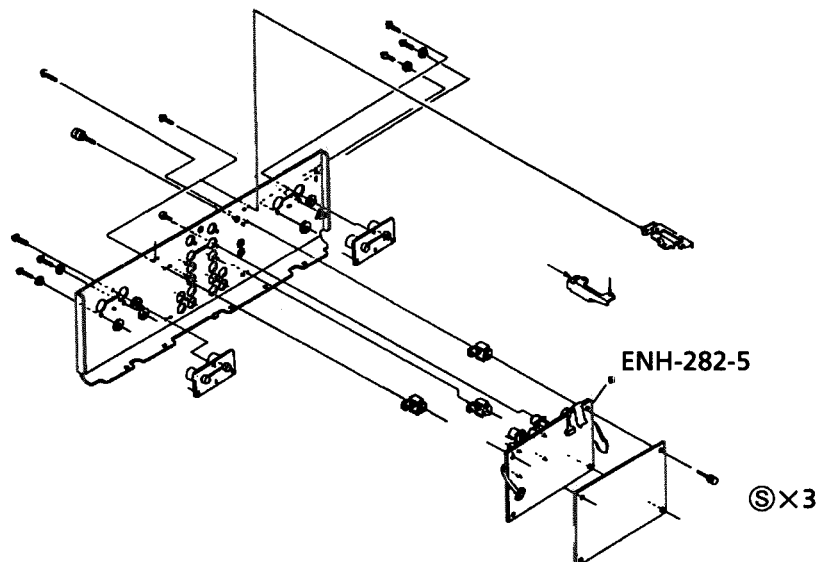
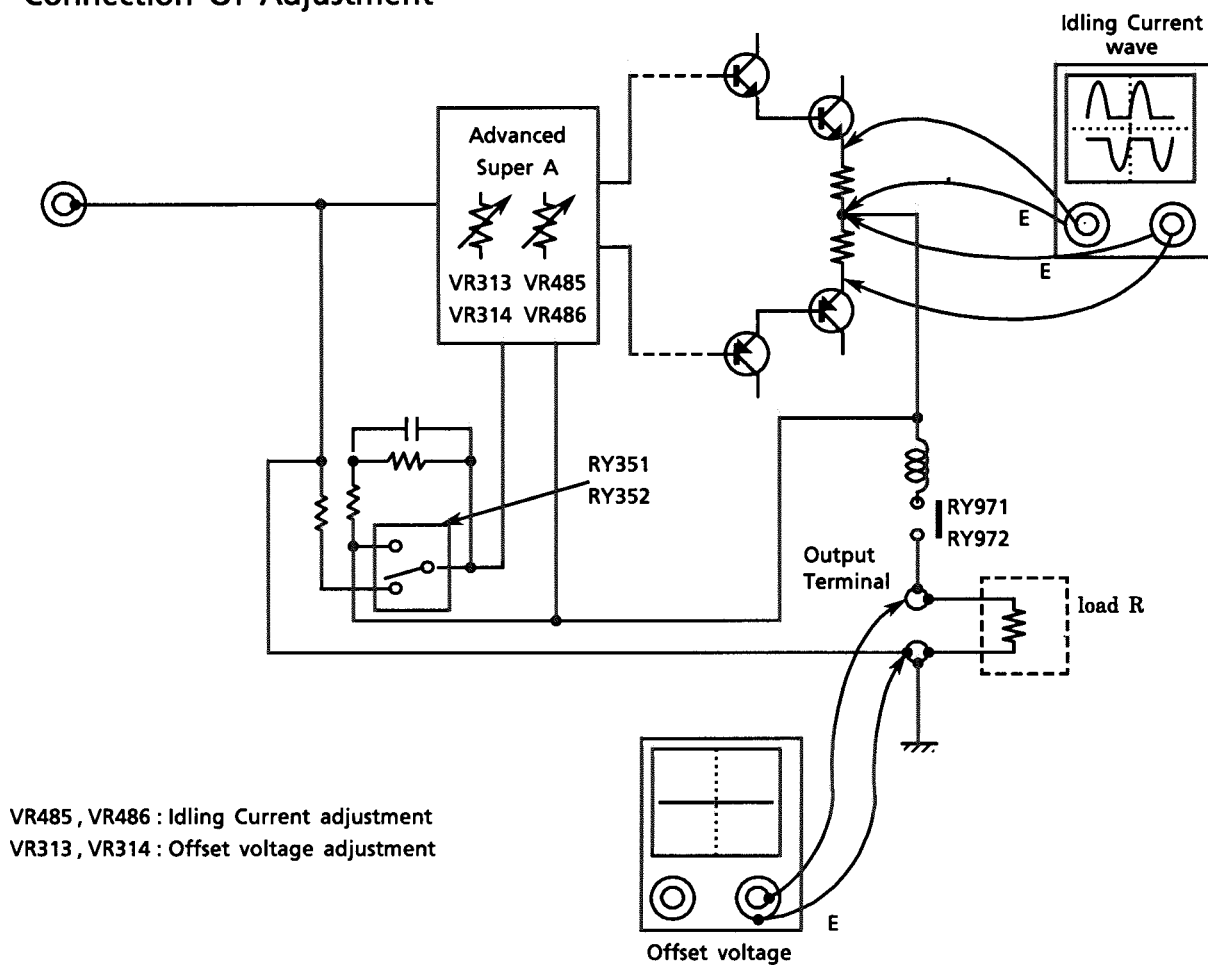

Fig-12 Rear panel ass'y

ADJUSTMENT PROCEDURES

■ Connection Of Adjustment



■ TEST Point / Adjustment Point

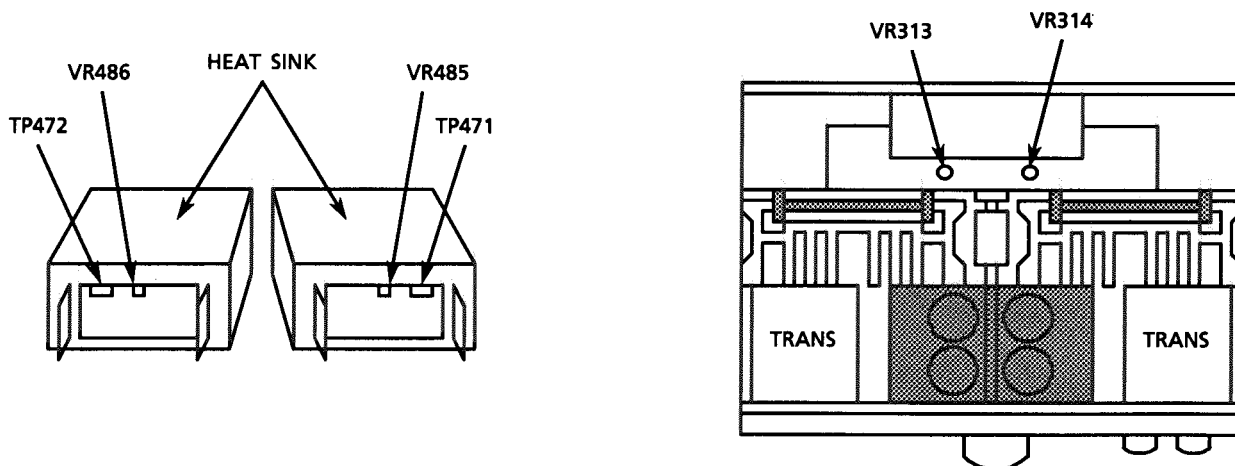

■ NOTICES BEFORE POWERING

AC primary voltage is set amp.'s rated voltage.

■ ADJUSTMENT PROCEDURES

* It varies slightly depending on Q301 and Q302.

1. Offset voltage Adjustment (No load and No signal)

1) Measurement points Speaker terminal

2) Adjustment points Lch : VR313 Rch : VR314

3) Adjustment Procedures

- (1) Turn ON. ON to set it "PRESENCE 3" and adjust VR313 and VR314 so that DC output from speakers becomes $0 \pm 10\text{mV}$.
- (2) Keep the unit for cooling down after the adjustment. Turn the unit ON and check that DC output is within $\pm 50\text{mV}$.

2. Main Amp Idling Current Adjustment (No load and No signal)

1) Measurement points

Lch : Between pins ① and ② of TP471, between pins ② and ③ of TP471
Rch : Between pins ① and ② of TP472, between pins ② and ③ of TP472

2) Adjustment points Lch : VR485 Rch : VR486

3) Adjustment Procedures

- (1) Set the volume control to minimum during this adjustment.
- (2) Turn R485 and R486 fully counterclockwise before the power is switch on.
- (3) Turn the power ON without load and signal while the top cover and the side panel assembled with the unit.
- (4) Check that there is no fault after the power ON and rotate VR485 and VR486 clockwise for its one third so that Lch and Rch can meet each target value described below after its specified time.
And, check the deviation between Lch and Rch is within 20%.

(Target value for adjustment)

Lch = 3.1mV (After 25sec.)

Rch = 2.2mV (After 35sec.)

P2-27-a

P2-27-b

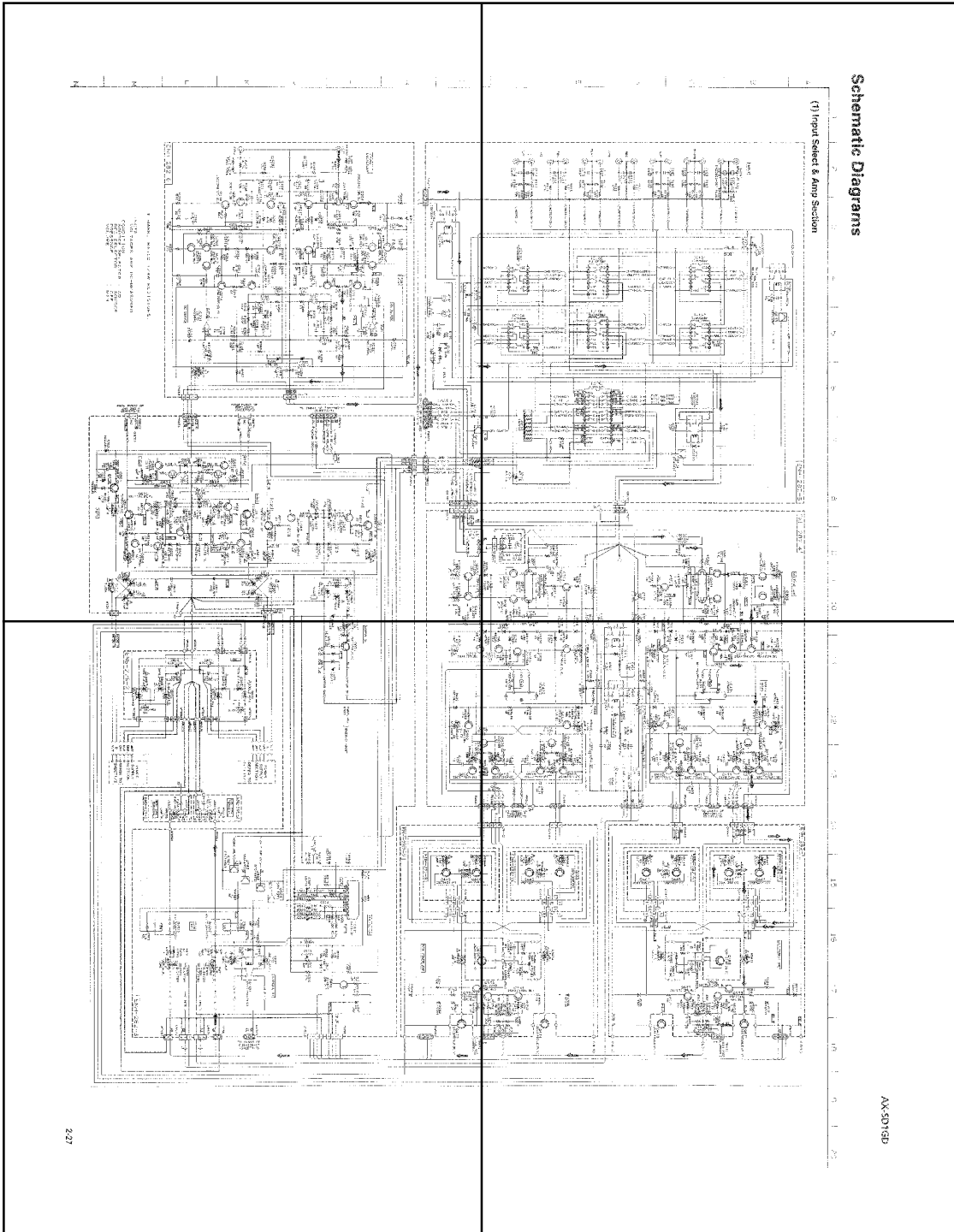

P2-27-c

P2-27-d

N
M
L
K
C
I
I
G

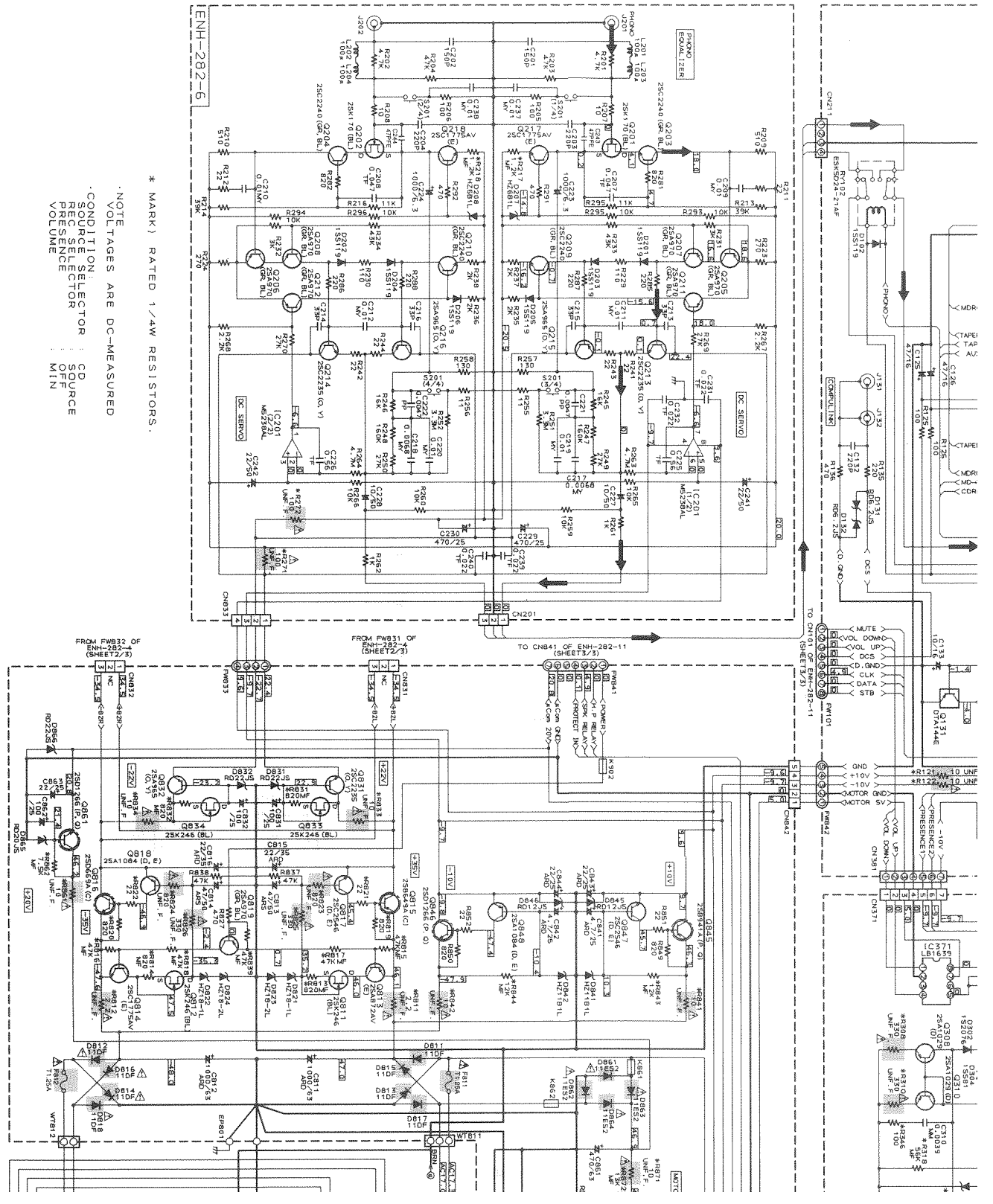

Schematic Diagrams

(1) Input Select & Amp Section

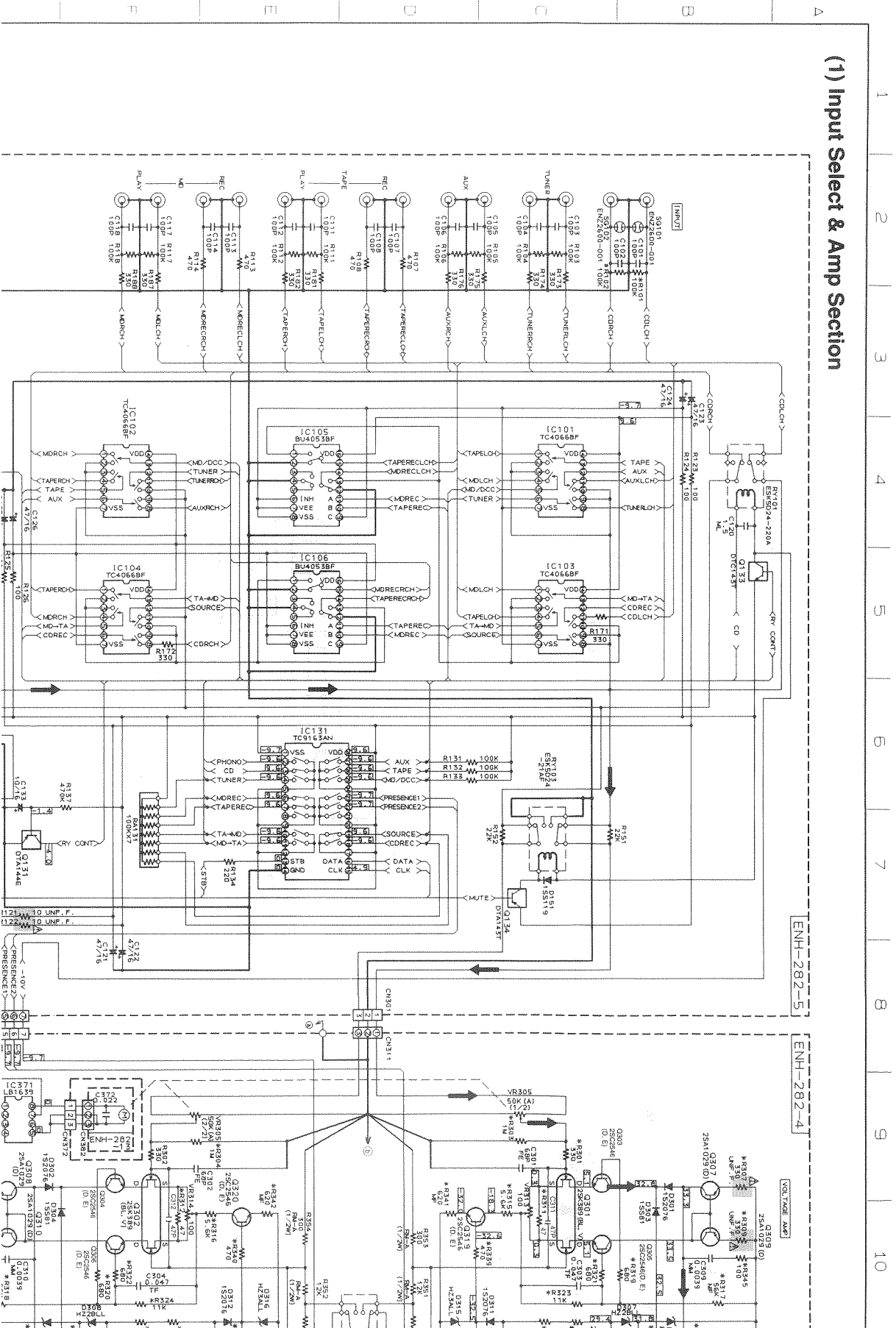

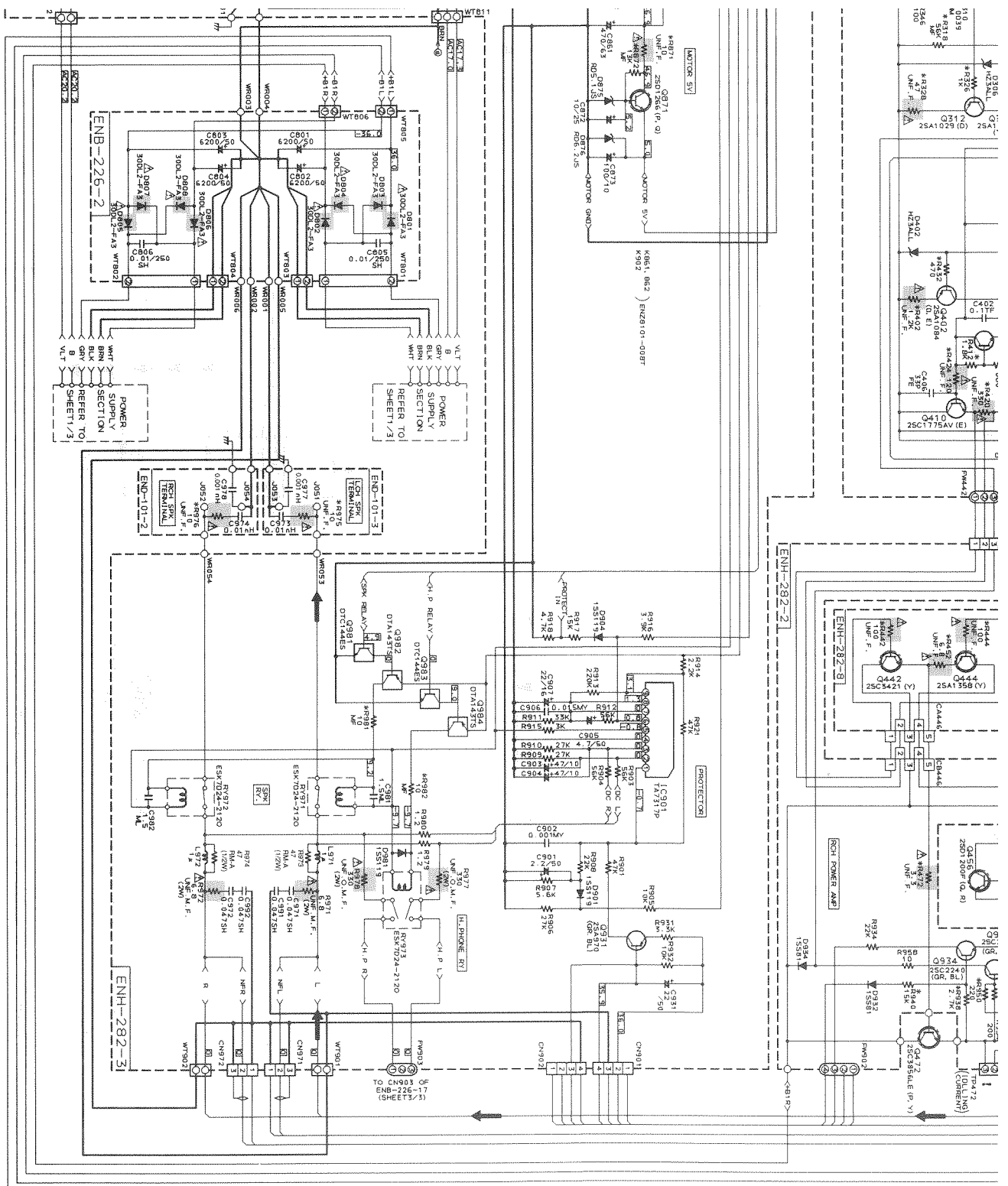

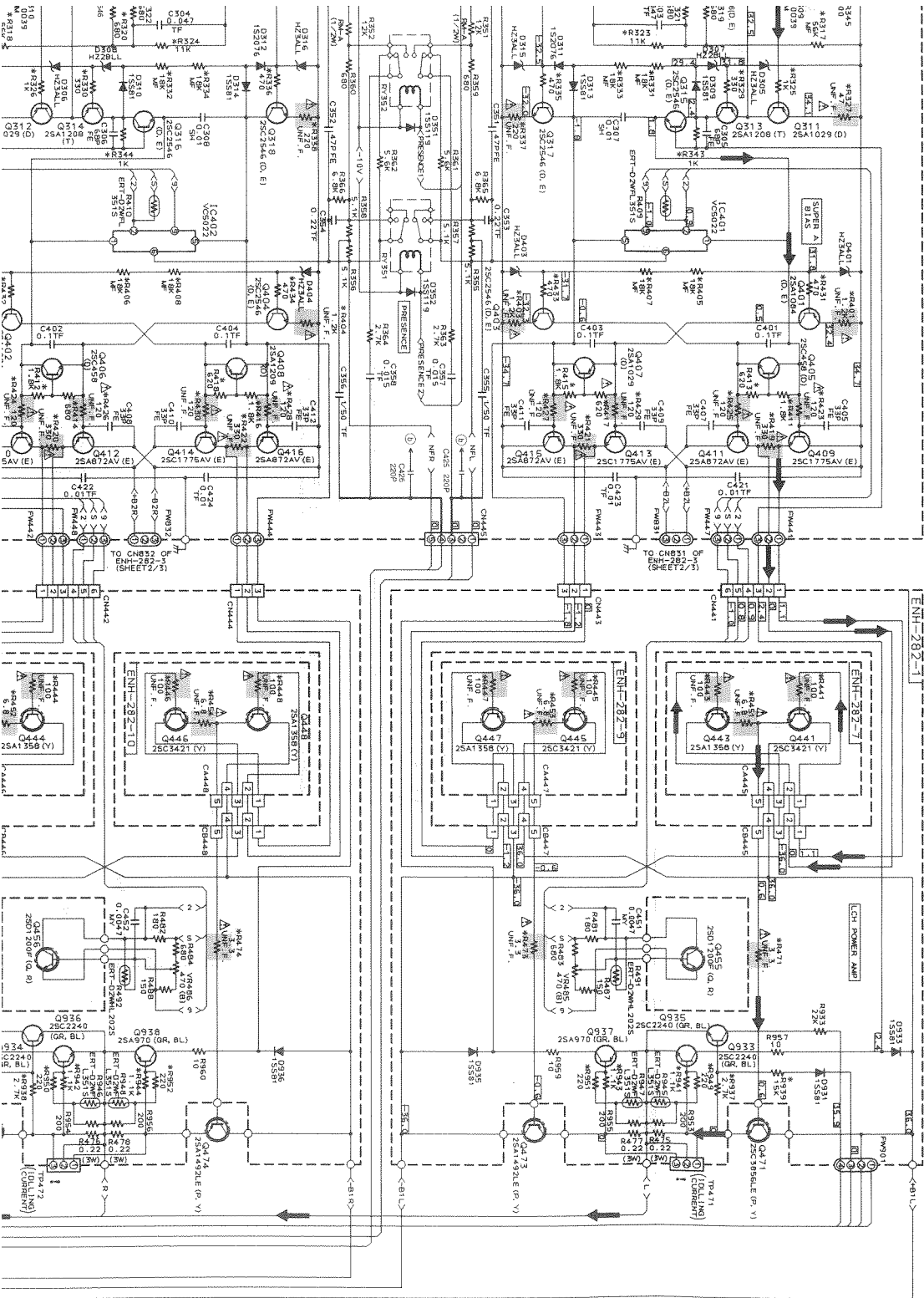

P2-28-a

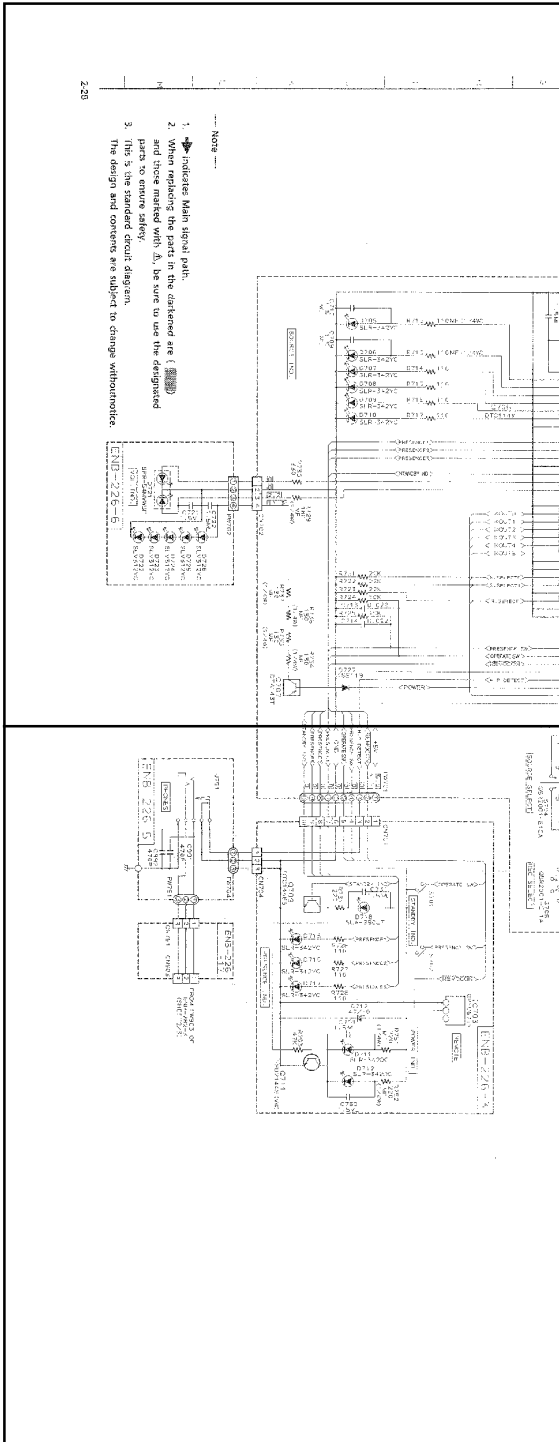

P2-28-b

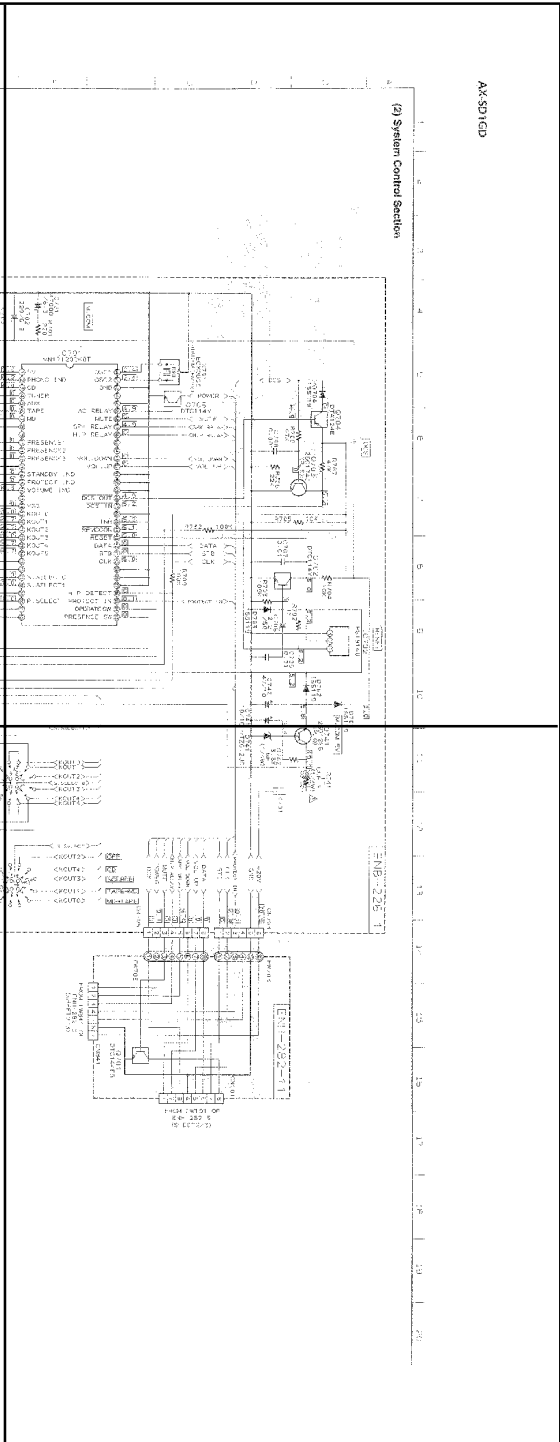

P2-28-c



P2-28-d



AXSDIGD
 (2) System Control Section
 Z28

Note ---
 1. ⚡ indicates Main signal path.
 2. When parts are shown as developed in () and those marked with ⚡, be sure to use the designated parts to ensure safety.
 3. This is the standard circuit diagram.
 The design and contents are subject to change without notice.

1. indicates Main signal path.
 2. When replacing the parts in the darkened are () and those marked with , be sure to use the designated parts to ensure safety.
 3. This is the standard circuit diagram.
- The design and contents are subject to change without notice.

— Note —

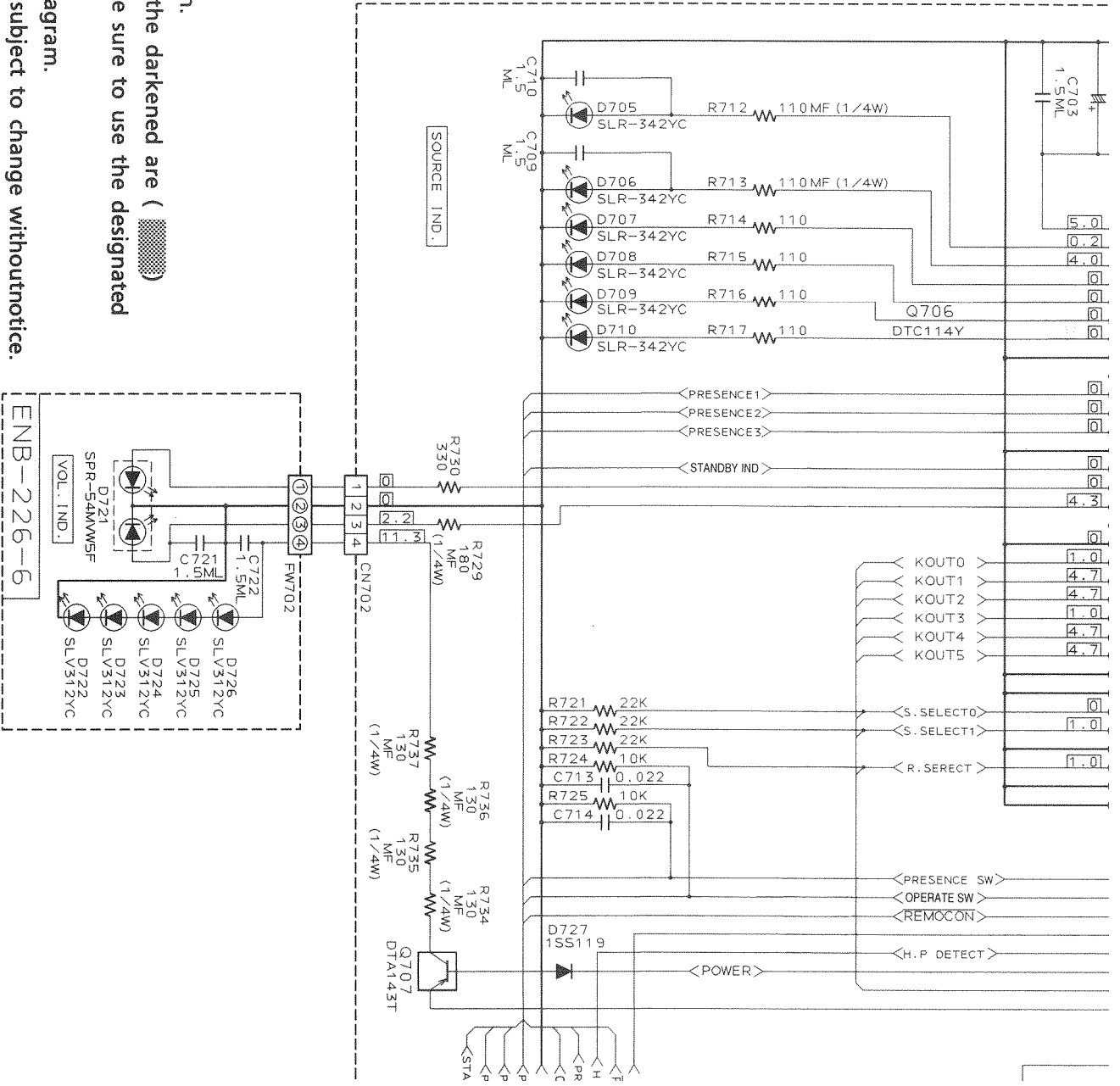

(2) System Control Section

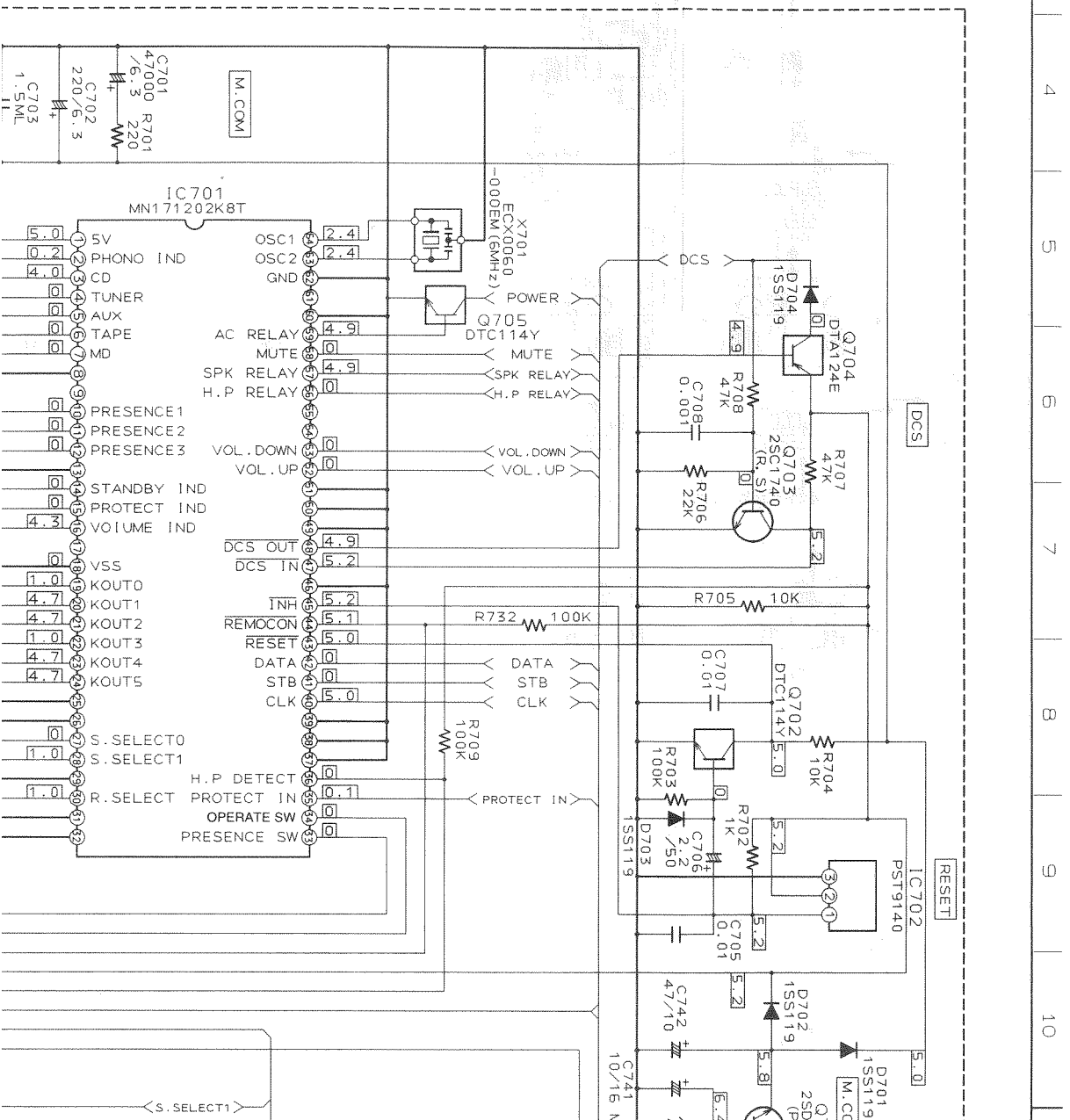

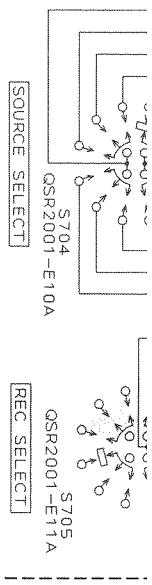
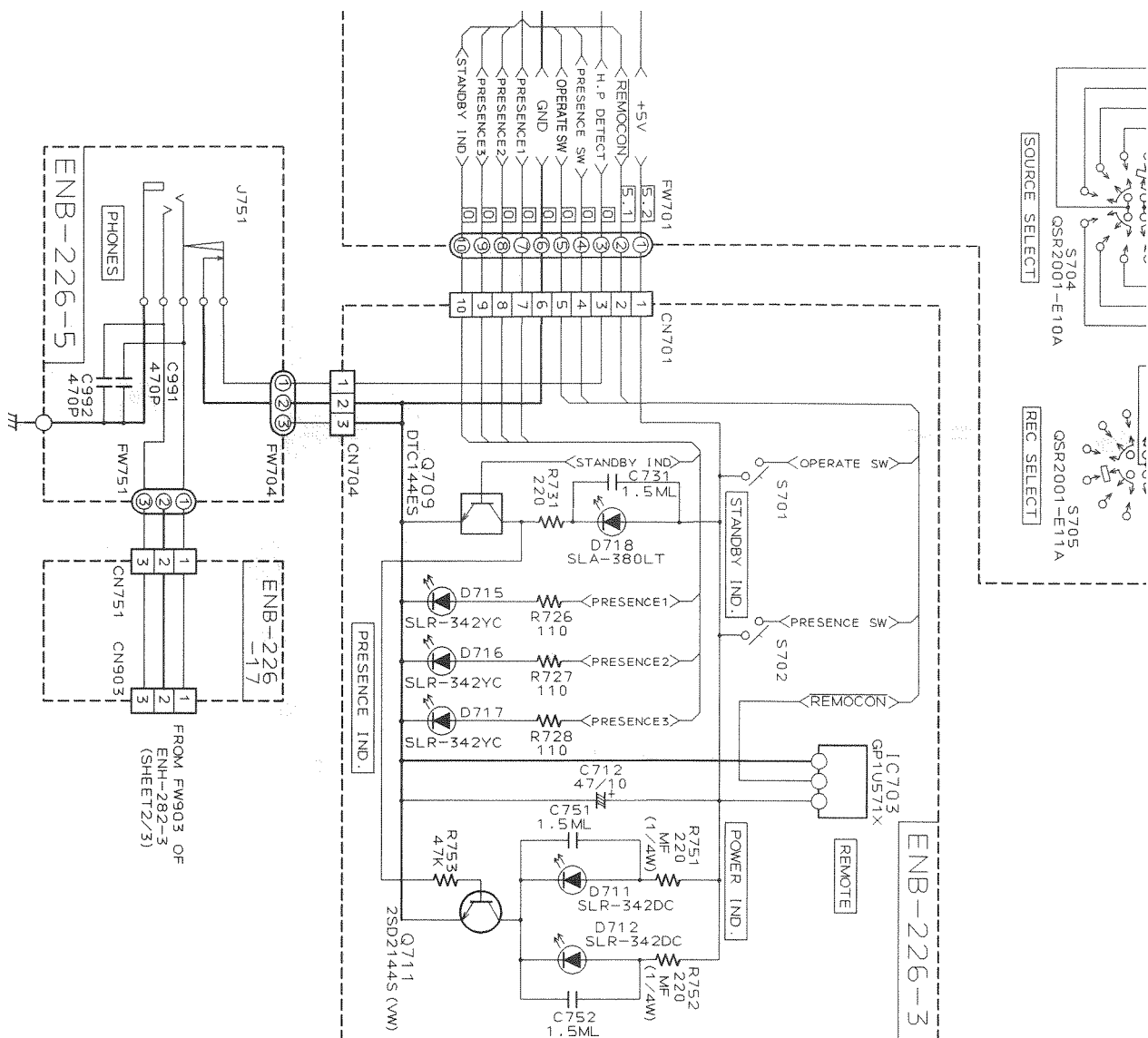

ENB-226-1

S.01

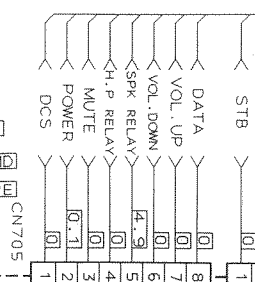
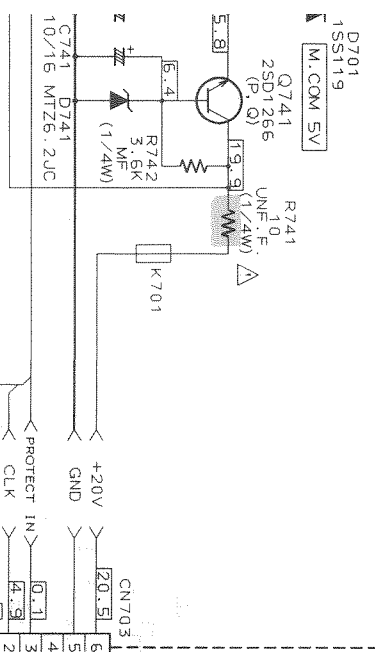

CNT703

CNT705

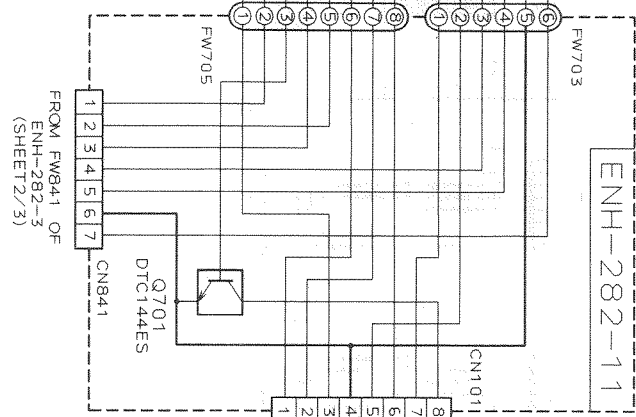

FROM FW101 OF
ENH-282-5
(SHEET2/3)

FROM FW841 OF
ENH-282-3
(SHEET2/3)

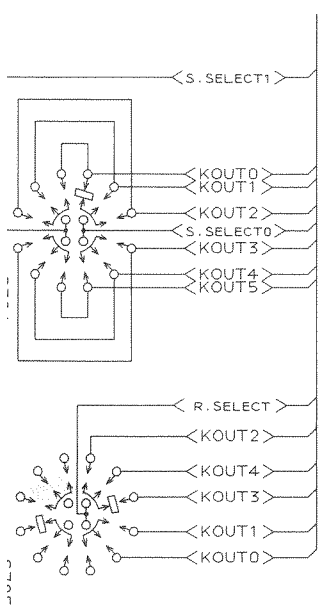

P2-29-a

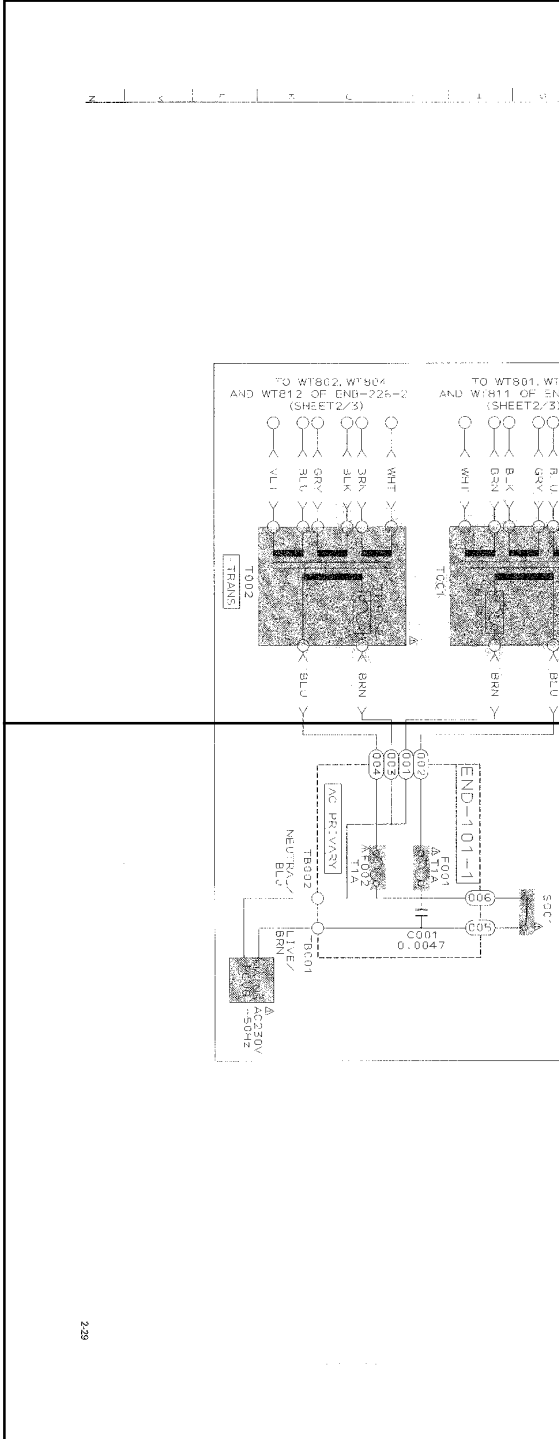

P2-29-b

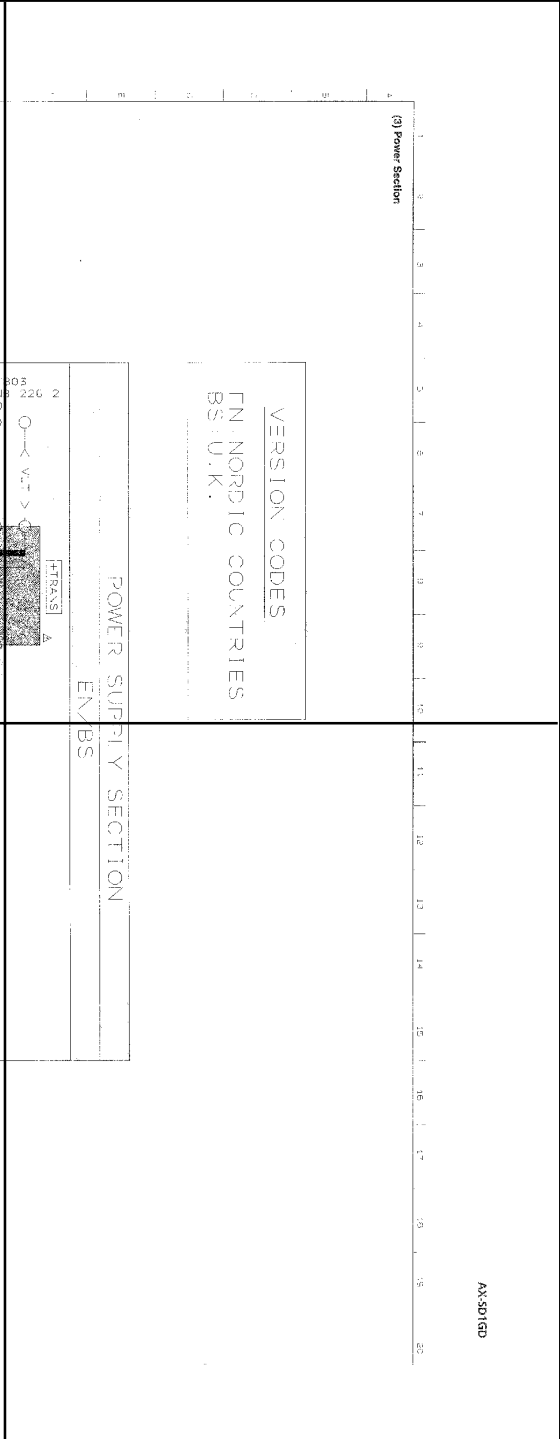

P2-29-c

P2-29-d

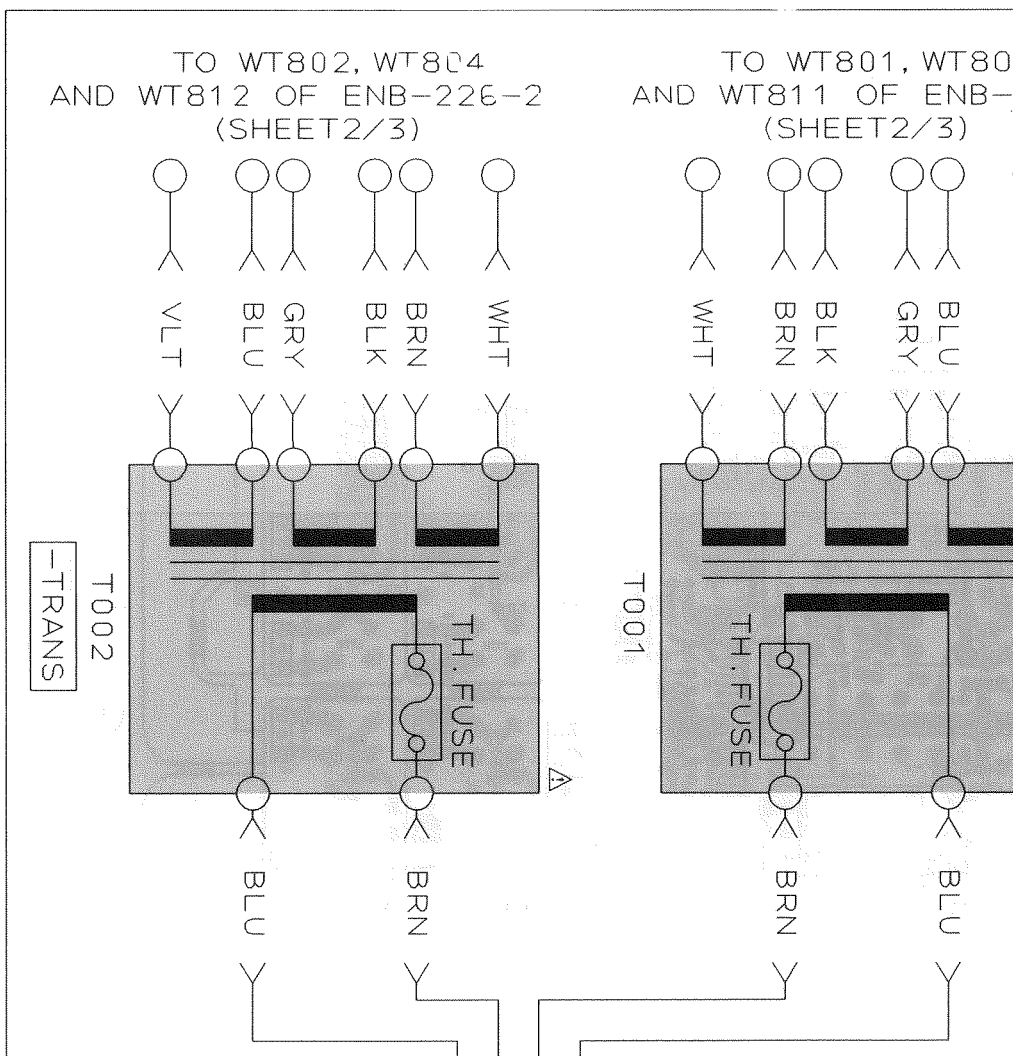

1 2 3 4 5 6 7 8 9 10

(3) Power Section

VERSION CODES
EN: NORDIC COUNTRIES
BS: U.K.

POWER SUPPLY
EN/B

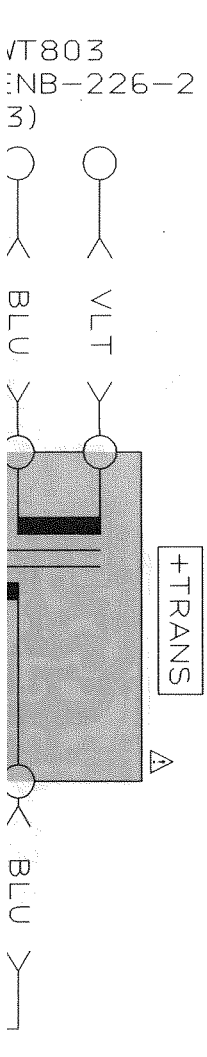

A B C D E F

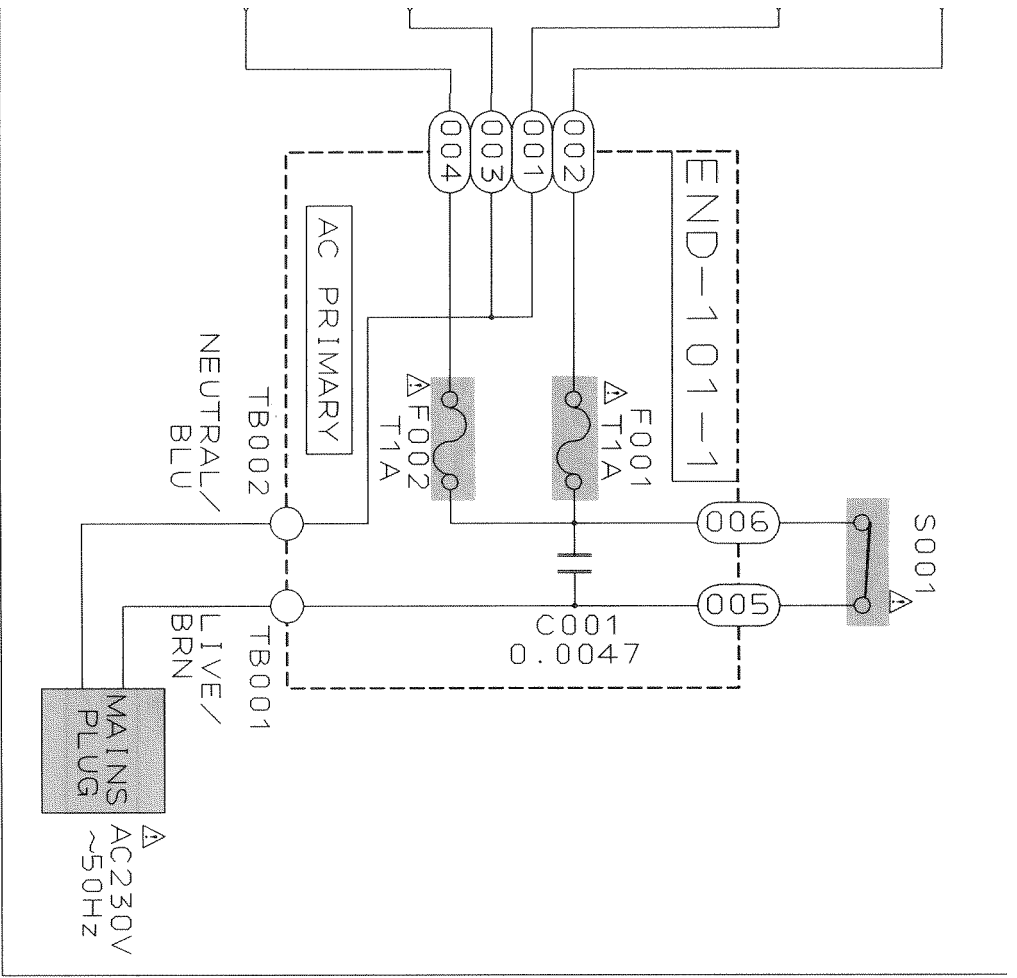

11 12 13 14 15 16 17 18 19 20

]

PLY SECTION
/BS

]]]]]]

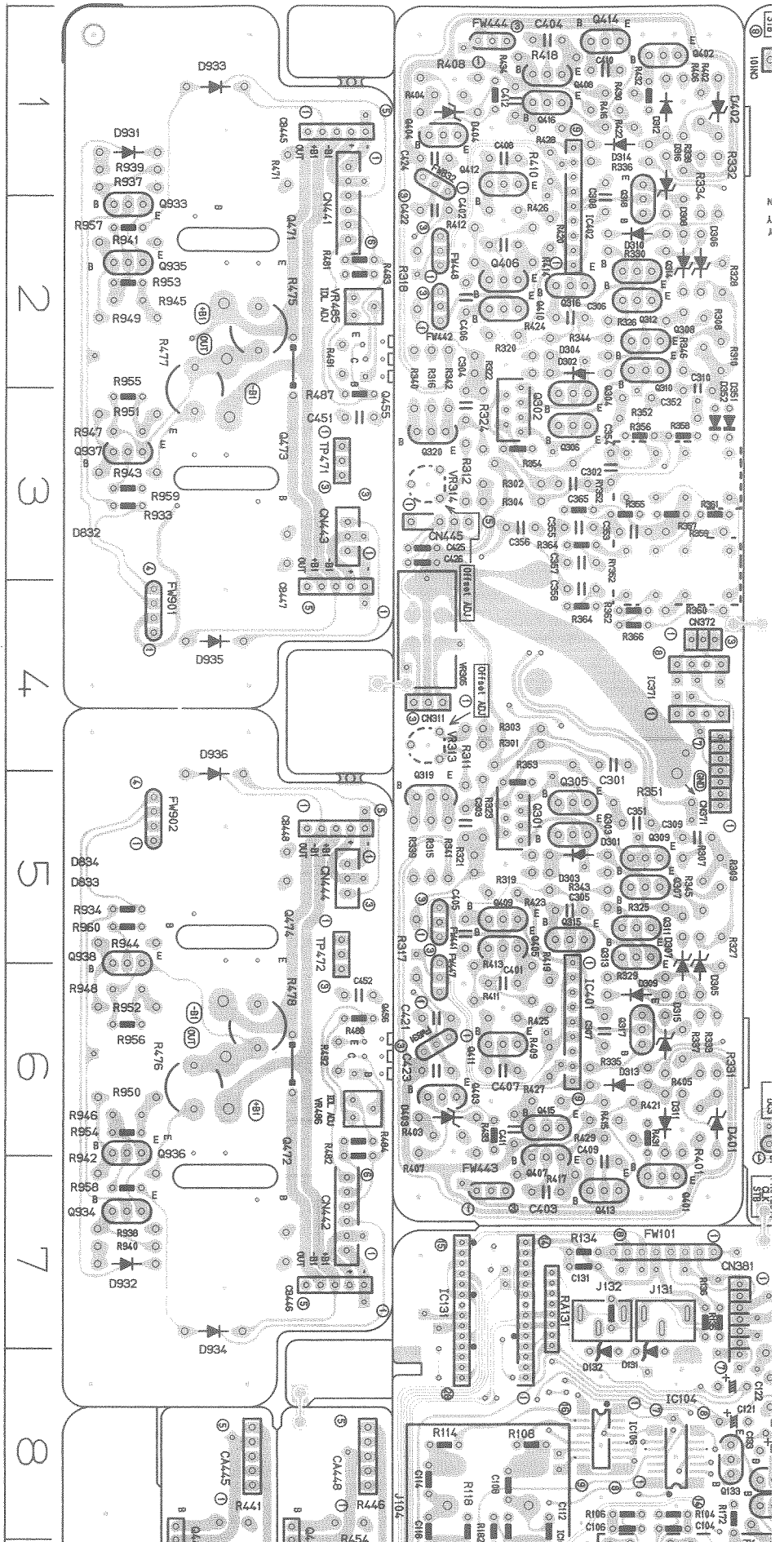

Printed Circuit Boards

(1) Input Select & Amp P. C. BOARD (ENH-282)

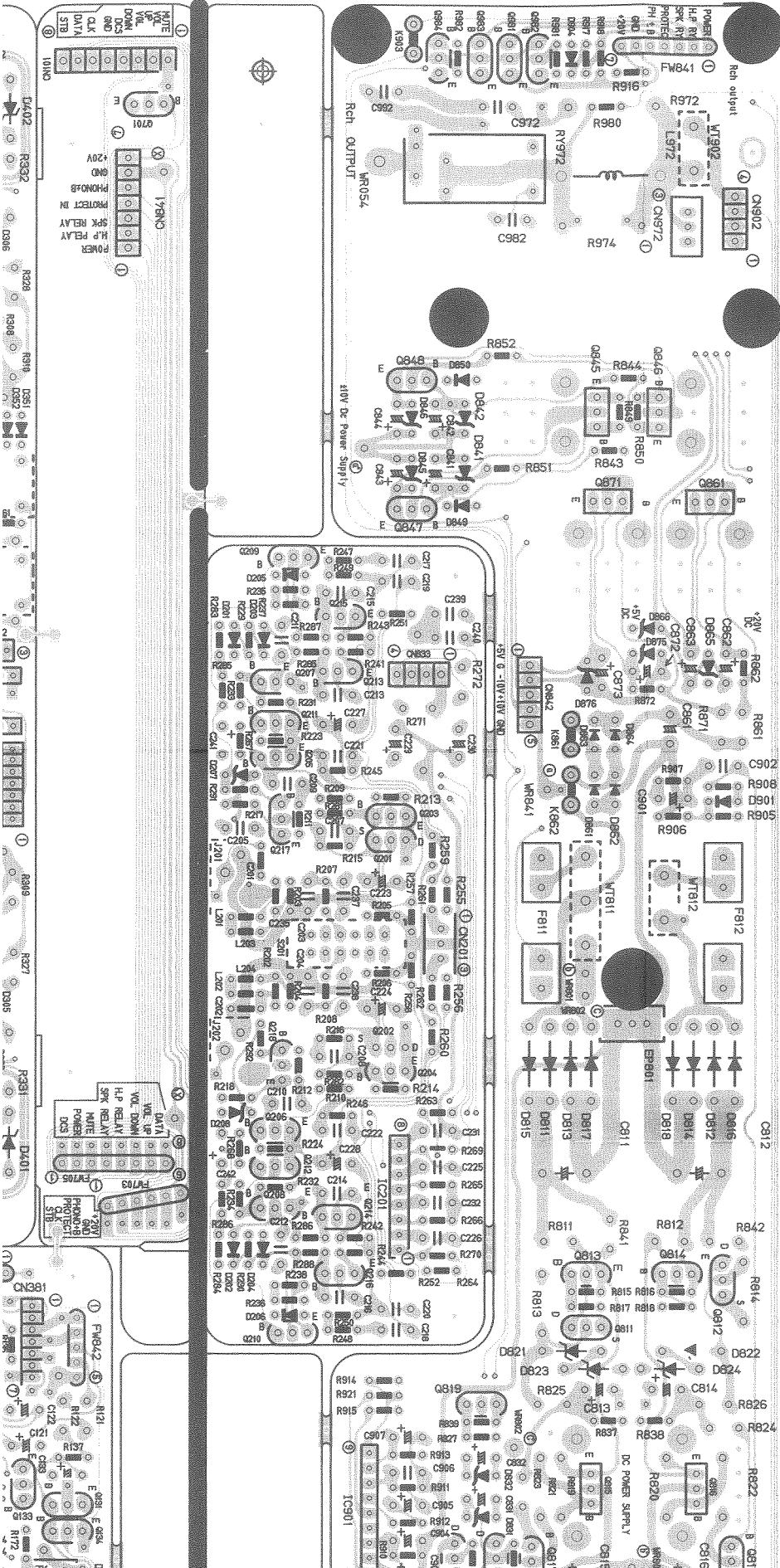

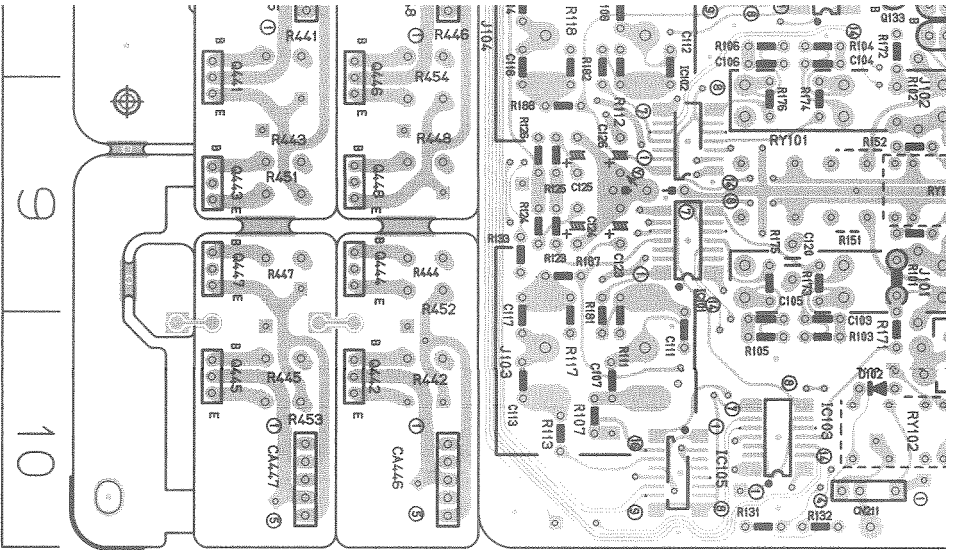

Section	Component	Value	Footprint	Mounting	Part Number	Quantity	Notes	Quantity	Notes					
E	C133	8 E	C356	3 D	CA445	8 B	D313	6 E	FW448	2 C	Q213	4 G	O815	8 I
	C201	5 G	C357	3 D	CA446	10 C	D314	1 E	FW703	7 F	Q214	7 G	O816	8 J
	C202	6 G	C358	4 D	CA447	10 B	D315	6 E	FW705	6 E	Q215	4 G	O817	8 I
	C203	5 G	C372	10 G	CA448	8 C	D316	1 E	FW831	6 C	Q216	7 G	O818	8 J
	C204	5 G	C401	6 D	CB445	1 B	D351	3 E	FW832	1 C	Q217	5 G	O819	8 H
	C205	5 G	C402	2 D	CB446	7 C	D352	3 E	FW833	9 I	Q218	6 G	O831	9 I
	C207	5 G	C403	7 D	CB447	4 C	D401	6 E	FW841	1 J	Q301	5 D	O832	9 H
	C208	6 G	C404	1 D	CB448	5 B	D402	1 E	FW842	7 F	Q302	3 D	O833	8 I
	C209	4 G	C405	5 C	CN101	1 F	D403	6 C	FW901	4 A	Q303	5 D	O834	8 H
	C210	6 G	C406	2 C	CN201	5 H	D404	1 C	FW902	5 A	Q304	3 D	O845	3 I
	C211	4 G	C407	6 D	CN211	10 E	D811	6 I	FW903	10 J	Q305	5 D	O846	3 J
	C212	7 G	C408	1 D	CN301	10 F	D812	6 J	IC101	9 D	Q306	3 D	O847	3 H
	C213	4 G	C409	7 D	CN311	4 C	D813	6 I	IC102	9 D	Q307	5 E	O848	2 H
	C214	7 G	C410	1 D	CN371	5 E	D814	6 J	IC103	10 E	Q308	2 E	O861	3 J
	C215	4 G	C411	6 D	CN372	4 E	D815	6 I	IC104	8 E	Q309	5 E	O871	3 I
	C216	7 G	C412	1 D	CN381	8 E	D816	6 J	IC105	10 D	Q310	2 E	O891	9 I
	C217	3 H	C421	6 C	CN382	10 G	D817	6 I	IC106	8 D	Q311	5 D	O933	2 A
	C218	7 H	C422	2 C	CN441	2 C	D818	6 J	IC131	8 D	Q312	2 D	O934	7 A
	C219	3 H	C423	6 C	CN442	7 C	D821	7 I	IC201	7 H	Q313	5 D	O935	2 A
	C220	7 H	C424	1 C	CN443	3 C	D822	7 J	IC371	4 E	Q314	2 D	O936	6 A
C221	4 G	C425	3 C	CN444	5 C	D823	7 I	IC401	5 D	Q315	5 D	O937	3 A	
C222	6 G	C426	3 C	CN445	3 C	D824	7 J	IC402	2 D	Q316	2 D	O938	5 A	
C223	5 H	C451	3 B	CN831	9 J	D831	8 I	IC901	9 H	Q317	6 E	O981	1 I	
C224	6 H	C452	6 B	CN832	9 J	D832	8 I	J101	9 E	Q318	2 E	O982	1 I	
C225	6 H	C811	6 I	CN833	4 H	D841	3 H	J102	9 E	Q319	5 C	O983	1 H	
C226	7 H	C812	6 J	CN841	1 F	D842	3 H	J103	9 C	Q320	3 C	O984	1 H	
C227	4 G	C813	8 I	CN842	4 I	D845	3 H	J104	8 C	Q401	7 E	R101	9 E	
C228	6 G	C814	8 J	CN901	10 J	D846	3 H	J131	7 E	Q402	1 E	R102	8 E	
C229	4 H	C815	9 I	CN902	2 J	D849	3 H	J132	7 D	Q403	6 C	R103	10 E	
C230	4 H	C816	9 J	CN971	9 J	D850	2 H	J201	5 G	Q404	1 C	R104	8 E	
C231	6 H	C831	8 H	CN972	2 J	D861	5 I	J202	6 G	Q405	5 D	R105	10 D	
C232	7 H	C832	8 H	D102	10 E	D862	5 I	K861	4 I	Q406	2 D	R106	8 D	

R172	8 E	R259	5 H	R334	2 E	R427	6 D	R833	9 I	R953	2 A
R173	9 E	R260	6 H	R335	6 E	R428	1 D	R834	9 J	R954	6 A
R174	9 E	R261	5 H	R336	1 E	R429	6 D	R837	8 I	R955	3 A
R175	9 E	R262	5 H	R337	6 E	R430	1 D	R838	8 J	R956	6 A
R176	9 E	R263	6 H	R338	2 E	R431	6 E	R839	8 H	R957	2 A
R181	9 D	R264	7 H	R339	5 C	R432	1 E	R841	7 I	R958	7 A
R182	8 D	R265	7 H	R340	3 C	R433	6 D	R842	7 J	R959	3 A
R187	9 C	R266	7 H	R341	5 C	R434	1 D	R843	3 I	R960	5 A
R188	9 C	R267	4 G	R342	3 C	R441	8 B	R844	2 I	R971	10 I
R201	5 G	R268	6 G	R343	5 D	R442	10 B	R849	3 I	R972	1 I
R202	5 G	R269	6 H	R344	2 D	R443	9 B	R850	3 I	R973	9 I
R203	5 G	R270	7 H	R345	5 E	R444	9 B	R851	3 H	R974	2 I
R204	5 G	R271	4 H	R346	2 E	R445	10 B	R852	2 H	R977	10 H
R205	5 H	R272	4 H	R351	5 D	R446	8 B	R861	4 J	R978	10 H
R206	5 H	R281	5 G	R352	3 D	R447	9 B	R862	4 J	R979	10 I
R207	5 G	R282	6 G	R353	4 D	R448	9 B	R871	4 J	R980	1 I
R208	5 G	R285	4 G	R354	3 D	R451	9 B	R872	4 I	R981	1 I
R209	5 G	R286	7 G	R355	3 D	R452	9 B	R901	9 I	R982	1 H
R210	6 G	R287	4 G	R356	3 D	R453	10 B	R903	9 H	RA131	7 D
R211	5 G	R288	7 G	R357	3 E	R454	9 B	R904	9 H	RY101	9 D
R212	6 G	R291	5 G	R358	3 E	R471	1 B	R905	5 J	RY102	10 E
R213	5 H	R292	6 G	R359	3 E	R472	7 B	R906	5 J	RY103	9 F
R214	6 H	R293	4 G	R360	4 E	R473	3 B	R907	4 J	RY351	3 E
R215	5 G	R294	7 G	R361	3 E	R474	5 B	R908	5 J	RY352	3 E
R216	6 G	R295	4 G	R362	4 D	R475	2 B	R909	9 H	RY971	10 I
R217	5 G	R296	7 G	R363	3 D	R476	6 A	R910	8 H	RY972	1 I
R218	6 G	R301	4 D	R364	4 D	R477	2 A	R911	8 H	RY973	10 I
R223	4 G	R302	3 D	R365	3 D	R478	6 B	R912	8 H	S201	5 G
R224	6 G	R303	4 D	R366	4 D	R481	2 B	R913	8 H	SG101	9 E
R229	4 G	R304	3 D	R401	6 E	R482	6 B	R914	8 H	SG102	9 E
R230	7 G	R307	5 E	R402	1 E	R483	2 B	R915	8 H	TP471	3 B

(2) Power P. C. B

Location List (ENH-282)

R107	10 D	X	Y	R231	4 G	X	Y	R308	2 E	X	Y	R403	6 C	X	Y	R484	6 B	X	Y	R916	1 I	X	Y	Symbol	X	Y
R108	8 D			R232	7 G			R309	5 E			R404	1 C			R487	3 B			R917	1 I			TP472	6 B	
R111	9 D			R233	4 G			R310	2 E			R405	6 E			R488	6 B			R918	1 I					
R112	8 D			R234	7 G			R311	5 C			R406	1 E			R491	2 B			R921	8 H					
R113	10 C			R235	3 G			R312	3 C			R407	6 C			R492	6 B			R931	9 I					
R114	8 C			R236	7 G			R315	5 C			R408	1 C			R811	7 I			R932	9 I					
R117	9 C			R237	4 G			R316	3 C			R409	6 D			R812	7 J			R933	3 A					
R118	8 C			R238	7 G			R317	6 C			R410	1 D			R813	7 I			R934	5 A					
R121	8 F			R241	4 G			R318	2 C			R411	6 D			R814	7 J			R937	1 A					
R122	8 F			R242	7 G			R319	5 D			R412	2 C			R815	7 I			R938	7 A					
R123	9 C			R243	4 G			R320	2 D			R413	6 C			R816	7 J			R939	1 A					
R124	9 C			R244	7 G			R321	5 D			R414	2 C			R817	7 I			R940	7 A					
R125	9 C			R245	4 G			R322	2 D			R415	6 D			R818	7 J			R941	2 A					
R126	9 C			R246	6 G			R323	5 C			R416	1 D			R819	8 I			R942	7 A					
R131	10 D			R247	3 G			R324	3 C			R417	7 D			R820	8 J			R943	3 A					
R132	10 E			R248	7 G			R325	5 E			R418	1 D			R821	8 I			R944	5 A					
R133	9 C			R249	3 G			R326	2 E			R419	6 D			R822	8 J			R945	2 A					
R134	7 D			R250	7 G			R327	6 E			R420	2 D			R823	8 I			R946	6 A					
R135	7 E			R251	4 H			R328	2 E			R421	6 D			R824	8 J			R947	3 A					
R136	7 E			R252	7 H			R329	6 E			R422	1 D			R825	8 I			R948	6 A					
R137	8 E			R255	5 H			R330	2 E			R423	5 D			R826	8 J			R949	2 A					
R151	9 E			R256	5 H			R331	6 E			R424	2 D			R827	8 H			R950	6 A					
R152	9 E			R257	5 H			R332	2 E			R425	6 D			R831	8 I			R951	3 A					
R171	9 E			R258	5 H			R333	6 E			R426	2 D			R832	8 H			R952	6 A					

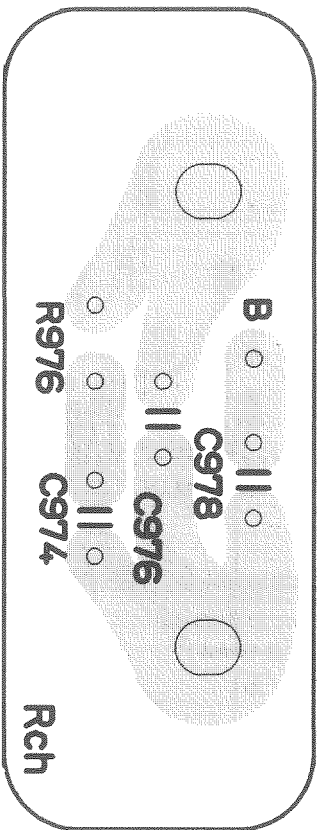
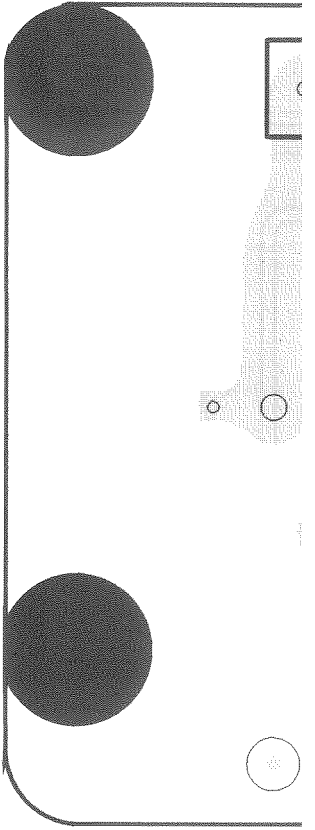

P. C. BOARD (ENA-101)

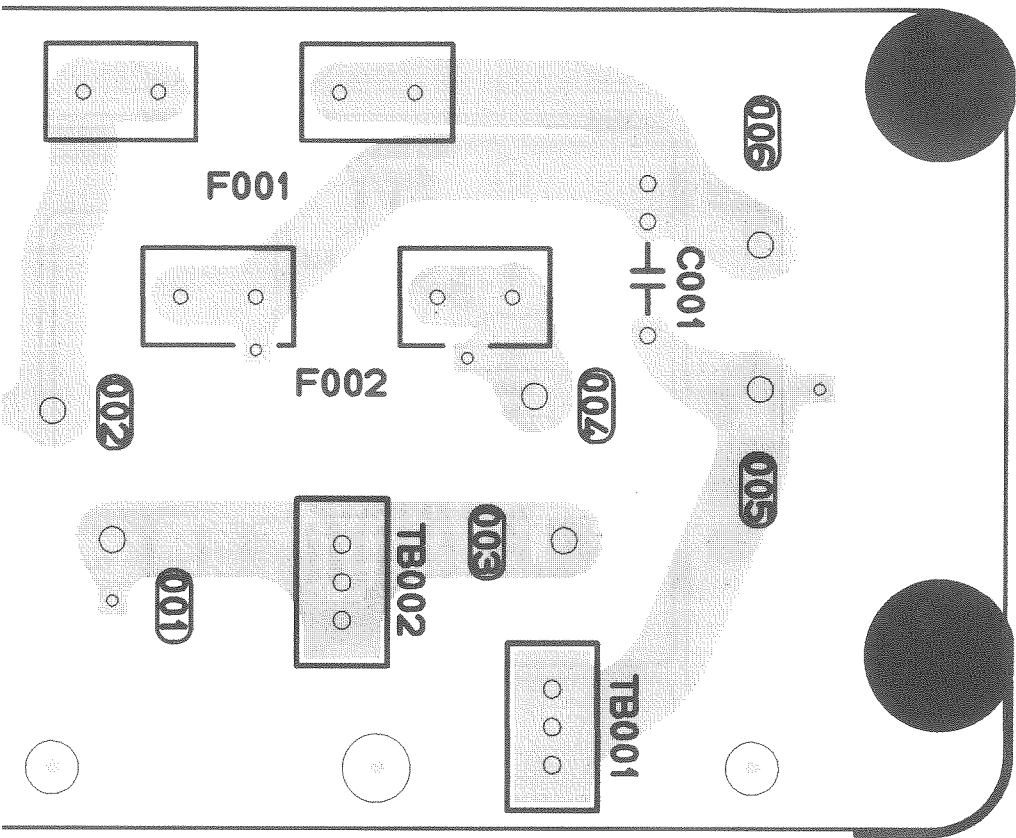

P2-32-a

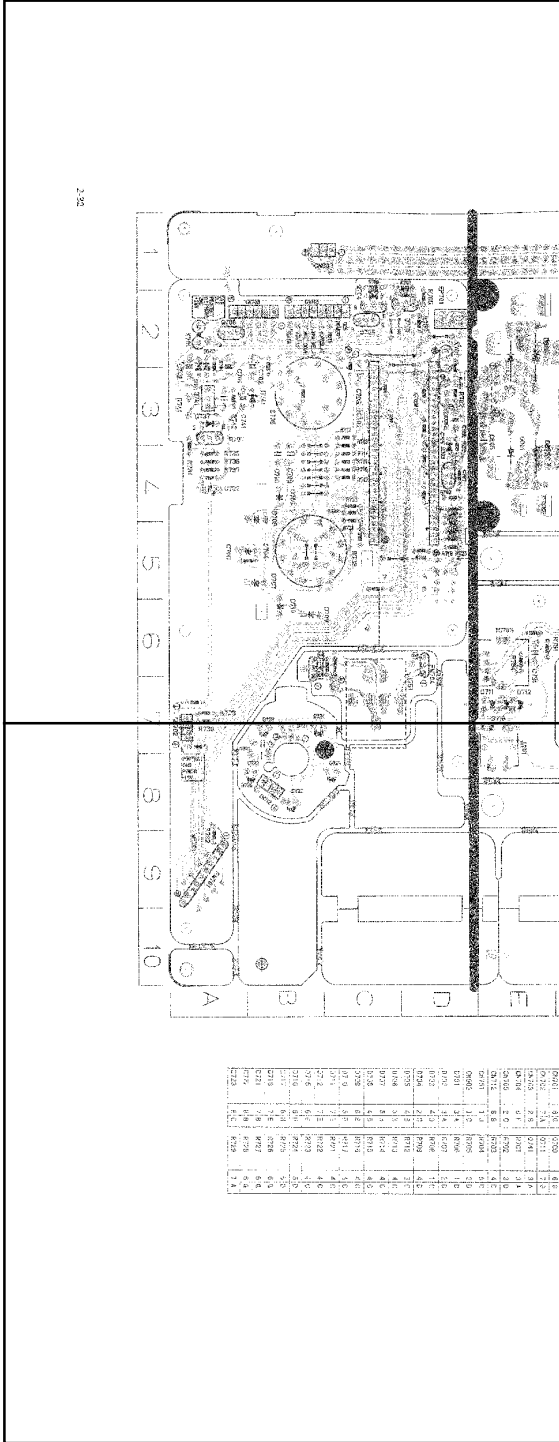

2.38

P2-32-c

P2-32-b

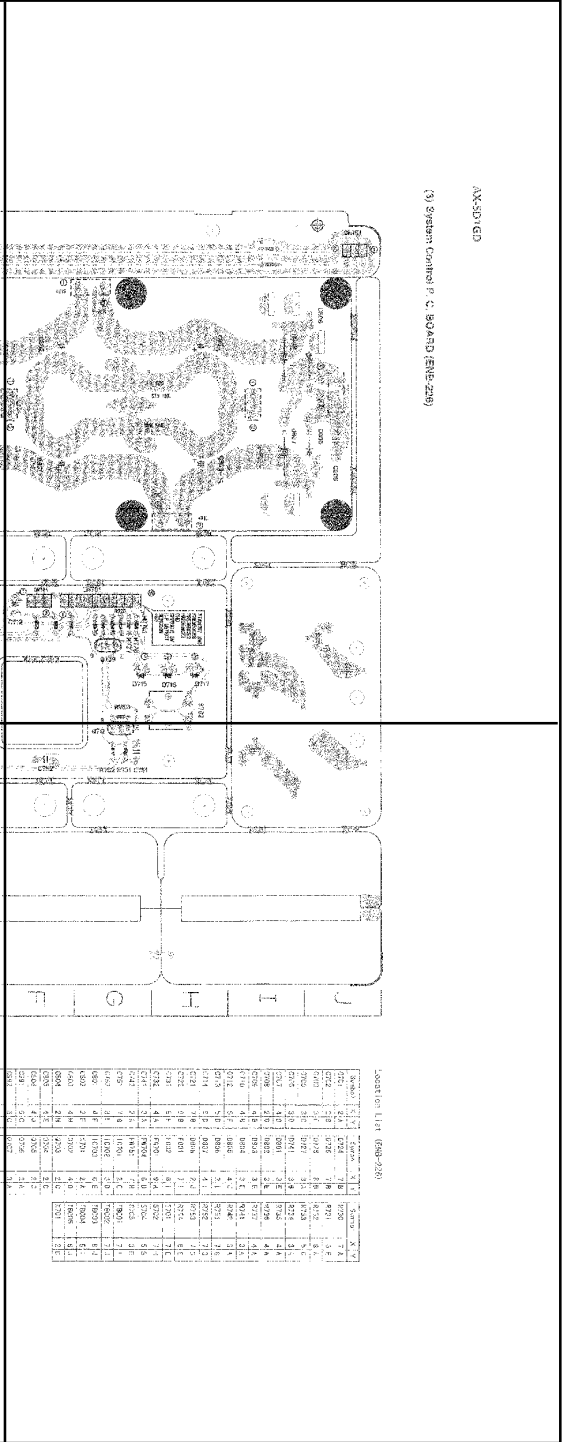

AX-50-IGD
 (3) System Control P. C. BOARD (ENR-226)

Asst. for L141 (ENR-226)

NO.	DESCRIPTION	QTY	UNIT	AMOUNT
1
2
3
4
5
6
7
8
9
10
11
12
13
14
15
16
17
18
19
20
21
22
23
24
25
26
27
28
29
30
31
32
33
34
35
36
37
38
39
40
41
42
43
44
45
46
47
48
49
50
51
52
53
54
55
56
57
58
59
60
61
62
63
64
65
66
67
68
69
70
71
72
73
74
75
76
77
78
79
80
81
82
83
84
85
86
87
88
89
90
91
92
93
94
95
96
97
98
99
100

P2-32-d

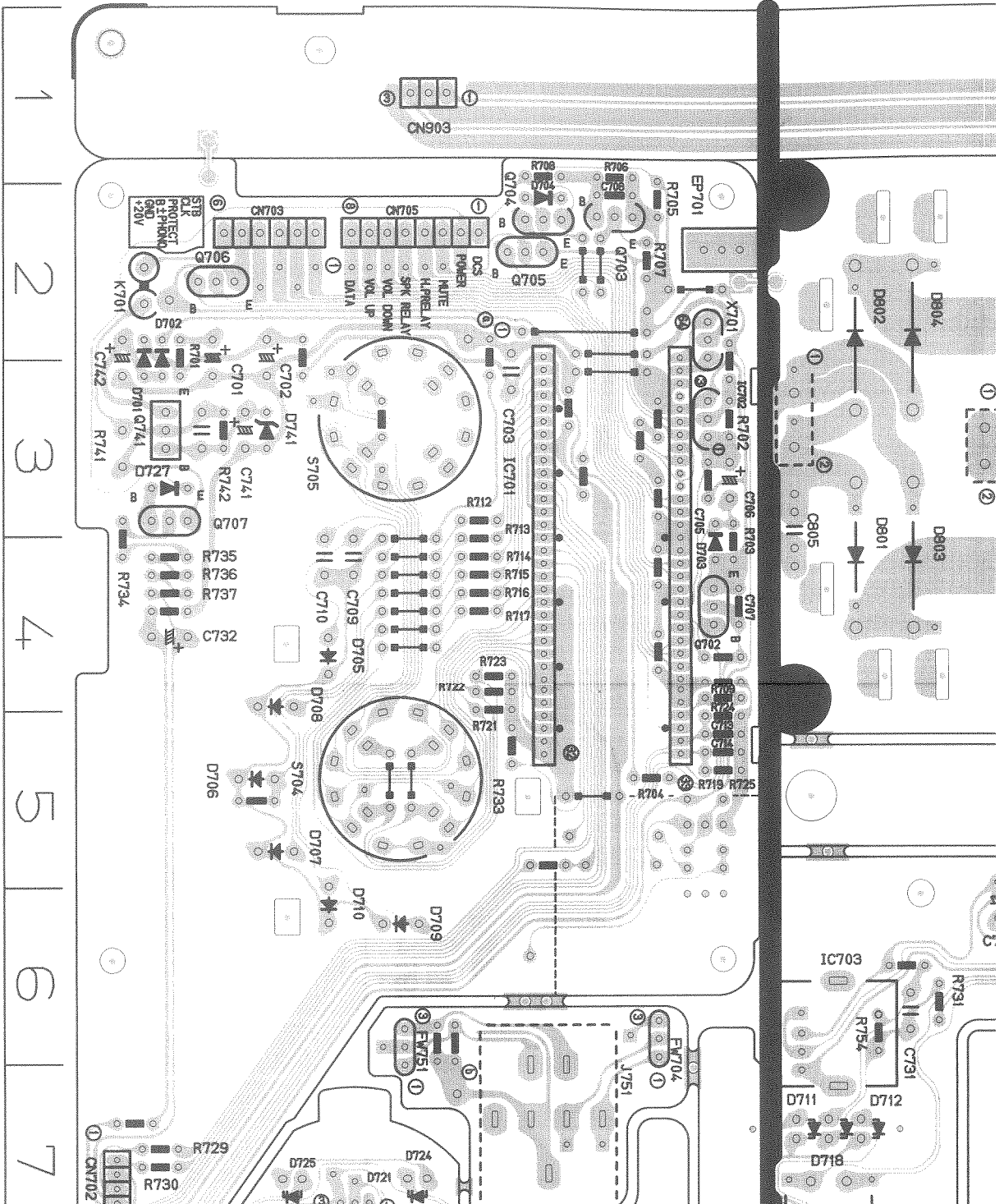

(3) System Control P. C. BOARD (ENB-226)

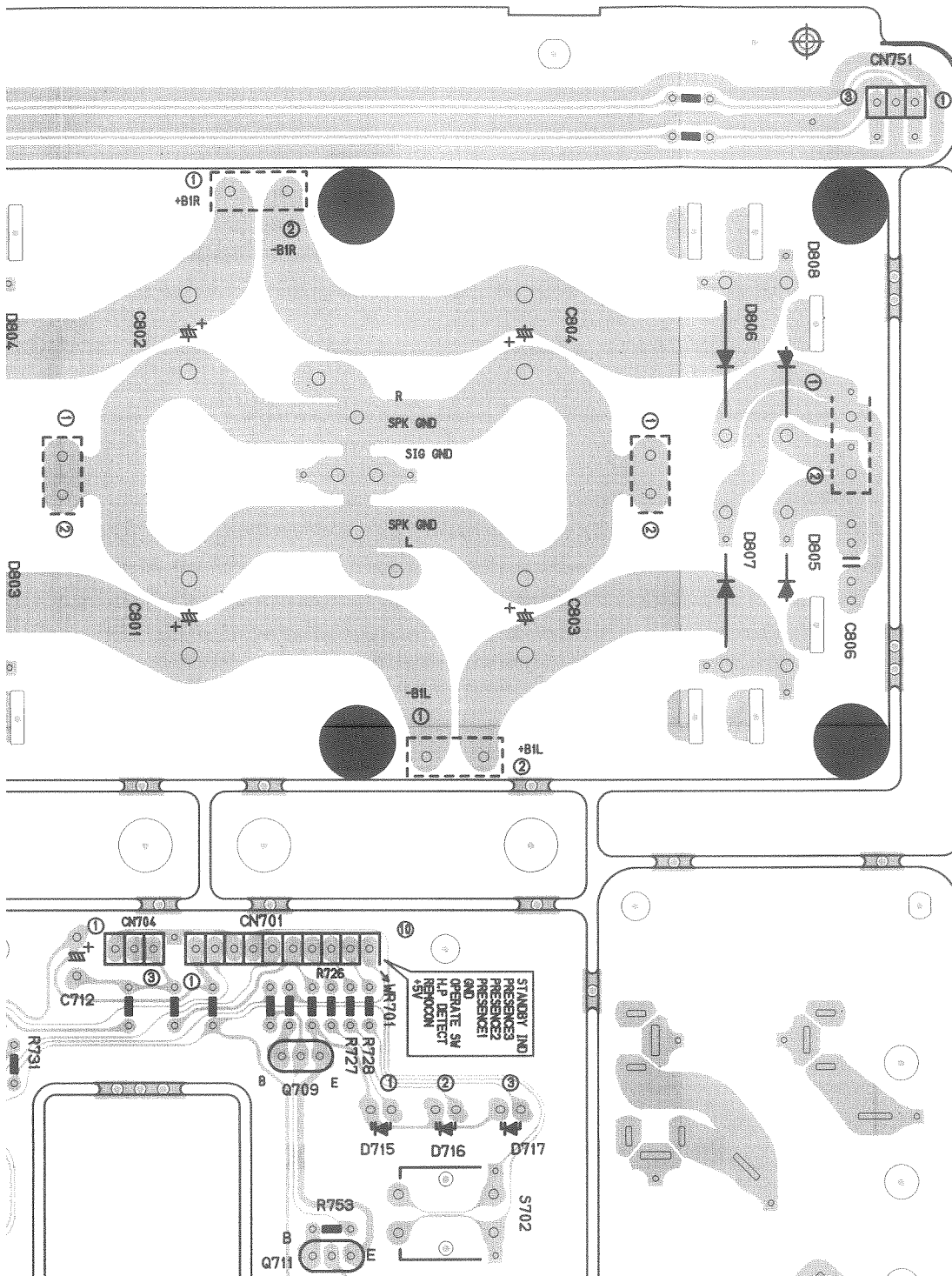

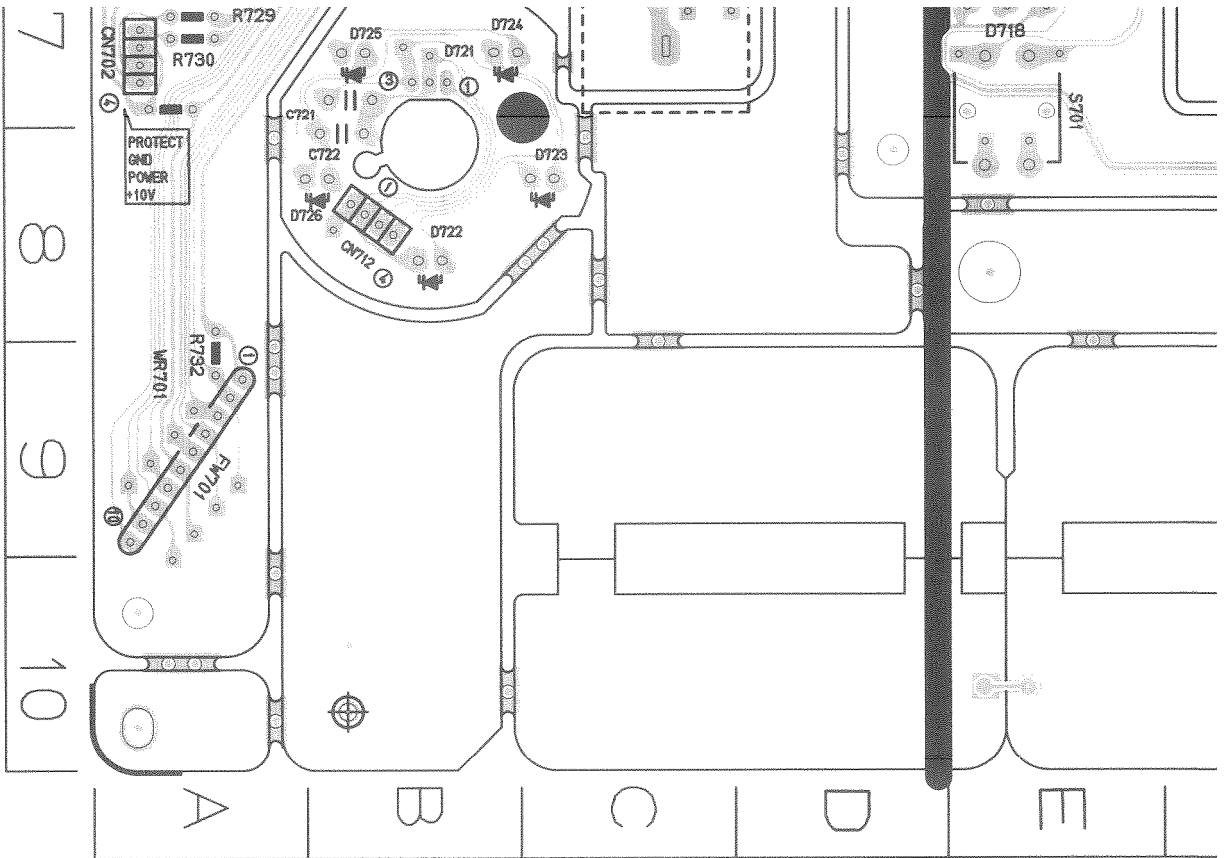

Q992	6 C	Q707	3 A
CN701	6 G	Q709	6 G
CN702	7 A	Q711	7 G
CN703	2 B	Q741	3 A
CN704	6 F	R701	3 A
CN705	2 C	R702	3 D
CN712	8 B	R703	4 D
CN751	1 J	R704	5 D
CN903	1 C	R705	2 D
D701	3 A	R706	1 D
D702	3 A	R707	2 D
D703	4 D	R708	1 C
D704	2 C	R709	4 D
D705	4 B	R712	3 C
D706	5 B	R713	4 C
D707	5 B	R714	4 C
D708	4 B	R715	4 C
D709	6 B	R716	4 C
D710	5 B	R717	4 C
D711	7 E	R721	4 C
D712	7 E	R722	4 C
D715	6 G	R723	4 C
D716	6 H	R724	5 D
D717	6 H	R725	5 D
D718	7 E	R726	6 G
D721	7 B	R727	6 G
D722	8 B	R728	6 G
D723	8 C	R729	7 A

Location List (ENB-226)

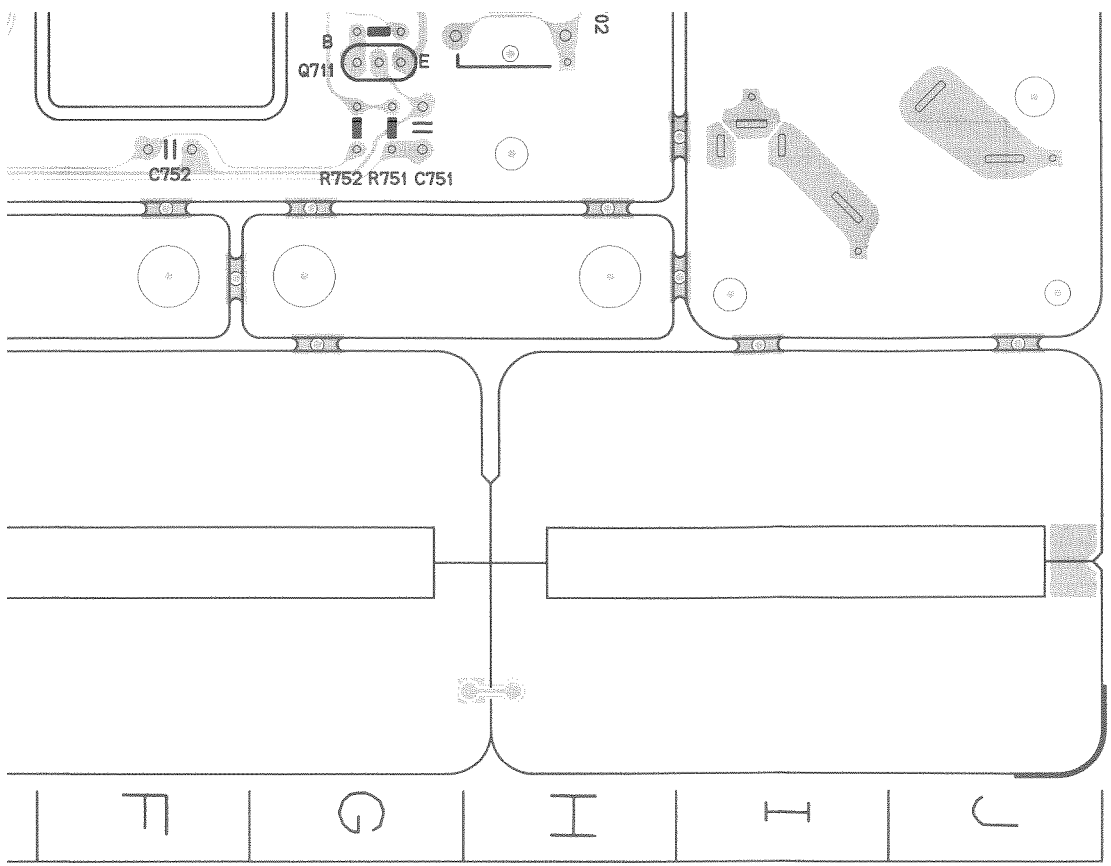

Symbol	X	Y	Symbol	X	Y	Symbol	X	Y
C701	2 A	2 A	D724	7 B	7 B	R330	7 A	7 A
C702	2 B	2 B	D725	7 B	7 B	R331	6 E	6 E
C703	3 C	3 C	D726	8 B	8 B	R332	8 A	8 A
C705	3 D	3 D	D727	3 A	3 A	R333	5 C	5 C
C706	3 D	3 D	D741	3 B	3 B	R334	3 A	3 A
C707	4 D	4 D	D801	3 E	3 E	R335	4 A	4 A
C708	2 D	2 D	D802	3 E	3 E	R336	4 A	4 A
C709	4 B	4 B	D803	3 E	3 E	R337	4 A	4 A
C710	4 B	4 B	D804	3 E	3 E	R741	3 A	3 A
C712	5 F	5 F	D805	4 J	4 J	R742	3 A	3 A
C713	5 D	5 D	D806	2 I	2 I	R751	7 G	7 G
C714	5 D	5 D	D807	4 I	4 I	R752	7 G	7 G
C721	7 B	7 B	D808	2 J	2 J	R753	7 G	7 G
C722	8 B	8 B	F001	7 I	7 I	R754	6 E	6 E
C731	6 E	6 E	F002	6 I	6 I	S701	7 E	7 E
C732	4 A	4 A	FW701	9 A	9 A	S702	7 H	7 H
C741	3 A	3 A	FW704	6 D	6 D	S704	5 B	5 B
C742	2 A	2 A	FW751	7 B	7 B	S705	3 B	3 B
C751	7 G	7 G	IC701	2 C	2 C	TB001	7 I	7 I
C752	8 F	8 F	IC702	3 D	3 D	TB002	7 J	7 J
C801	4 F	4 F	IC703	6 E	6 E	TB003	8 J	8 J
C802	2 F	2 F	K701	2 A	2 A	TB004	8 I	8 I
C803	4 H	4 H	Q702	4 D	4 D	TB005	6 J	6 J
C804	2 H	2 H	Q703	2 C	2 C	X701	2 D	2 D
C805	4 E	4 E	Q704	2 C	2 C			
C806	4 J	4 J	Q705	2 C	2 C			
C891	6 C	6 C	Q706	2 A	2 A			
C892	6 C	6 C	Q707	3 A	3 A			
CN701	6 G	6 G	Q709	6 G	6 G			

PARTS LIST

* All printed circuit boards and its assemblies are not available as service parts.

The Marks for Designated Areas

BS - the U.K. EN - Scandinavia No marks indicates all areas.

- Contents -

General Exploded View and Parts List	3-3
Electrical Parts List	3-6
(ENH-282)	3-6
(ENB-226)	3-12
(END-101)	3-13
Accessories List	3-13
Packing Materials and Part Numbers	3-15

General Exploded View and Parts List

Block No. **M1MM**

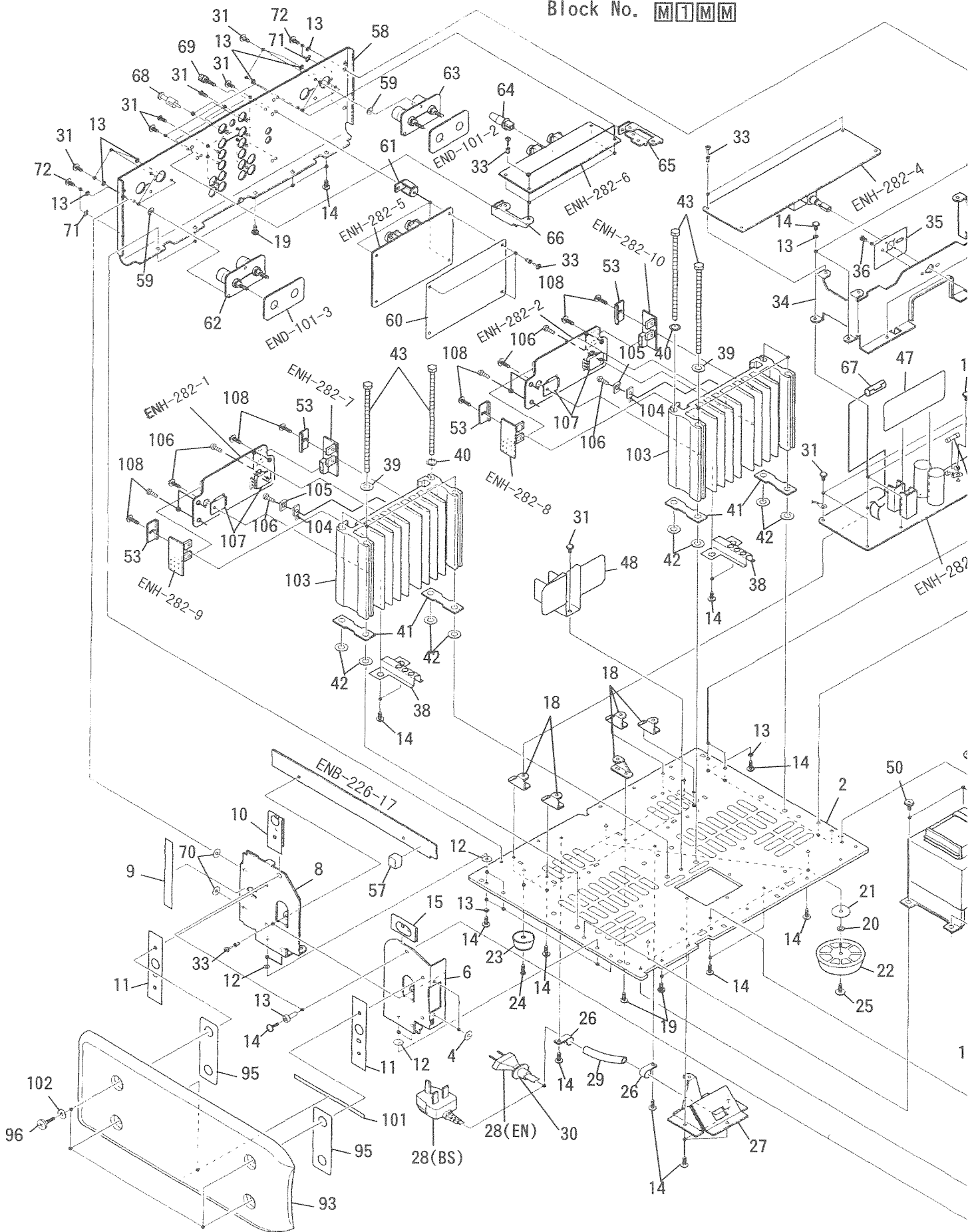

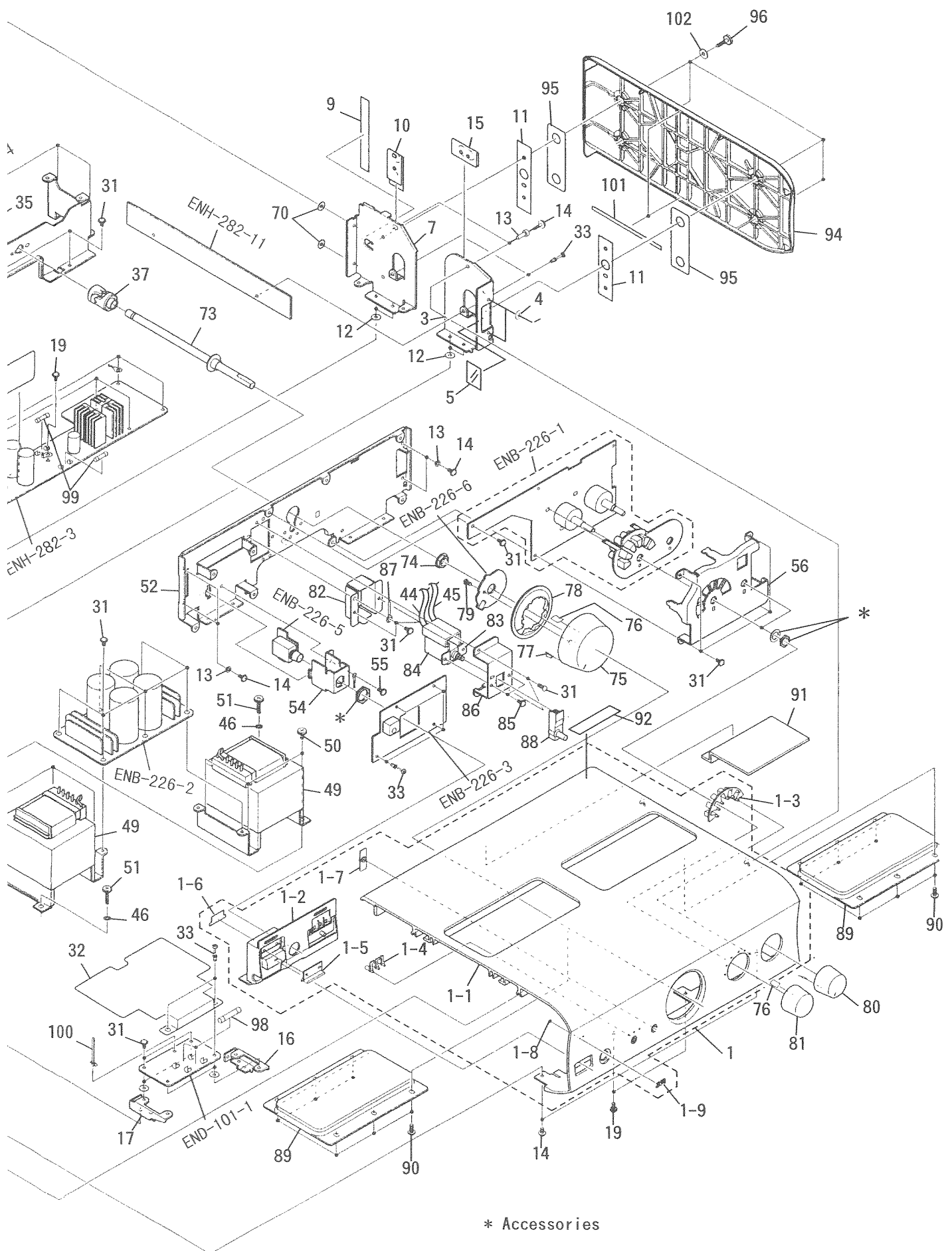

* Accessories

AX-SD1GD

Parts List

Block No. **M1M1M1**

△	Item	Parts Number	Parts Name	Q'ty	Description	Area
	1	EFP-AXSD1GDE(S)	FRONT PANEL ASSY	1		
	1-1	E102977-002	FRONT PANEL	1		
	1-2	E103027-003	PUSH BUTTON ASSY	1		
	1-3	E309299-001	INDICATOR LENS	1	SOURCE	
	1-4	E408524-001	INDICATOR LENS	1	PRS	
	1-5	E408526-001	REMOTE CONTROL WINDOW	1		
	1-6	E408747-001	SPACER	1		
	1-7	E409209-002	BUTTON ESCUTCHEON	1	POWER	
	1-8	E60912-003	SPEED NUT	1		
	1-9	E409213-002	JVC MARK	1		
	2	E102979-002	BOTTOM PLATE	1		
	3	E309302-005	SIDE BRACKET	1		
	4	E73967-001	SPACER	4		
	5	E306805-171	SPACER	1		
	6	E309302-006	SIDE BRACKET	1		
	7	E309303-007	SIDE BRACKET	1	RIGHT	
	8	E309303-008	SIDE BRACKET	1	LEFT	
	9	E409516-001	ACETATE TAPE	2		
	10	E408756-001	SPACER	2		
	11	E408756-002	SPACER	4		
	12	E73967-016	SPACER	8		
	13	BUSH-PUL	BUSHING	22		
	14	GBSG3008CC	TAPPING SCREW	42		
	15	E408758-001	SPACER	2		
	16	E408528-003	P. W. BOARD BRACKET	1	RIGHT	
	17	E408528-004	P. W. BOARD BRACKET	1	LEFT	
	18	E68587-004	ARM BRACKET	5		
	19	E408499-002	ASSY SCREW	5		
	20	WSS5000CC	WASHER	3		
	21	E409508-001	SPACER	3		
	22	E309292-002	FOOT ASSY	3		
	23	E47227-008	FOOT	2		
	24	SBSG3010CC	TAPPING SCREW	2		
	25	E65389-006	SPECIAL SCREW	3		
	26	E408556-001	WIRE CLAMP	2		
	27	E309306-002	CORD BRACKET	1		
△	28	QMP3900-200	POWER CORD	1		EN
△	28	QMP5530-0085BS	POWER CORD	1		BS
	29	QXT6820-090	TUBE	1		
△	30	QHS3771-108	CORD STOPPER	1		
	31	GBSG3006CC	SCREW	44		
	32	E310124-001	SHIELD PLATE	1		
	33	E48729-007	PLASTIC RIVET	17		
	34	E208441-003	VOLUME BRACKET	1		
	35	E408744-001	SPACER	1		
	36	SBST3004CC	TAPPING SCREW	2		
	37	E307792-001	JOINT ASSY	1		
	38	E408555-002	PROTECTOR COVER	2		
	39	E408176-001	WASHER	6		
	40	WAS5000CC	WASHER	2		
	41	E409210-001	SPACER	4		
	42	WSS6000CC	WASHER	8		
	43	E406831-008	SCREW	8		
	44	QWE883-13FR	VINYL WIRE	1	005	
	45	QWE884-13FR	VINYL WIRE	1	006	
	46	WBS4000CC	WASHER	2		
	47	E309462-001	SHIELD PLATE	1		
	48	E310027-002	PROTECTOR COVER	1		
△	49	ETP1100-56EA	POWER TRANSFORMER	2	PT001, PT002	
	50	E61660-007	SPECIAL SCREW	6		
	51	E61661-003	SPECIAL SCREW	2		

■ Parts List

Block No. **M1M1M**

△	Item	Parts Number	Parts Name	Q'ty	Description	Area
	52	E102980-005	FRONT BRACKET	1		
	53	E408013-001	TRANS. BRACKET	4		
	54	E408527-002	JACK BRACKET	1		
	55	E408499-001	SCREW	1		
	56	E208444-002	KNOB BRACKET	1		
	57	E306805-188	SPACER	1		
	58	E208442-003	REAR PANEL	1		
	59	E407406-003	SPACER	6		
	60	E309461-002	SHIELD PLATE	1		
	61	E408529-002	P. C. BOARD BRACKET	3		
	62	E309329-009ST	SPEAKER TERMINAL	1	RIGHT	
	63	E309329-010ST	SPEAKER TERMINAL	1	LEFT	
	64	E407321-002SM	PUSH BUTTON	1		
	65	E408528-003	P. C. BOARD BRACKET	1	RIGHT	
	66	E408528-004	P. C. BOARD BRACKET	1	LEFT	
	67	ENZ8104-004	NOISE FILTER	1	FW833	
	68	E03449-001	SHORT PLUG	2		
	69	E408091-001	EARTH PLUG	1		
	70	E73967-010	SPACER	4		
	71	WBS3000CC	WASHER	2		
	72	SBSG3008CC	TAPPING SCREW	4		
	73	E309296-002	VOLUME SHAFT	1		
	74	E71862-003	VOLUME NUT	1		
	75	E309294-001	VOLUME KNOB	1		
	76	E408294-001	SPACER	3		
	77	E408525-002	INDICATOR LENS	1		
	78	E309298-001	INDICATOR LENS	1		
	79	SDSF2608Z	SCREW	1		
	80	E309297-001	SELECT KNOB	1		
	81	E309297-002	SELECT KNOB	1		
	82	E309921-001	COVER BRACKET	1		
△	83	QSP1106-004	PUSH SWITCH	1	S001	
	84	E71004-001	SWITCH COVER	1		
	85	SBST3006CC	TAPPING SCREW	2		
	86	E309922-001	SWITCH BRACKET	1		
	87	E72018-001	WIRE CLAMP	1		
	88	E409208-001	PUSH BUTTON	1		
	89	E208920-003	GRILLE	2		
	90	E61661-005	SPECIAL SCREW	12		
	91	E409256-001	SHIELD PLATE	1		
	92	E409396-001	CAUTION LABEL	1		
	93	E102981-019	SIDE PANEL	1	LEFT	
	94	E102981-020	SIDE PANEL	1	RIGHT	
	95	E409351-001	SPACER	4		
	96	E74274-003	SPECIAL SCREW	8		
△	98	QMF51E2-1R0J1	FUSE	2	F001, F002 (T1.0A/250V)	
△	99	QMF51A2-1R25	FUSE	2	F811, F812 (T1.25A/250V)	
	100	E307572-001	VINYL TIE	1		
	101	E409366-001	SPACER	4		
	102	E409352-003	WASHER	8		
	103	E309307-002	HEAT SINK	2		
	104	2SD1200F	TRANSISTOR	2	Q456 Q455	
	105	E408022-001	SHIELD PLATE	2		
	106	E73525-003	SCREW	4		
	107	-----	TRANSISTOR	1	Q471~Q474 See page 3-14	
	108	GBSG3010CC	SCREW	12		
	-	E61029-005	NUMBER LABEL	1		

■ Electrical Parts List (ENH-282)

△	Item	Parts Number	Description	Area
		I. C. S		
	IC101	TC4066BF	I. C(DIGI-MOS)	
	IC102	TC4066BF	I. C(DIGI-MOS)	
	IC103	TC4066BF	I. C(DIGI-MOS)	
	IC104	TC4066BF	I. C(DIGI-MOS)	
	IC105	BU4053BF	I. C(DIGI-MOS)	
	IC106	BU4053BF	I. C(DIGI-MOS)	
	IC131	TC9163AN	I. C(DIGI-MOS)	
	IC201	M5238AL	I. C(MONO-ANALOG)	
	IC371	LB1839-CV	I. C(DIGI-OTHER)	
	IC401	VC5022 (X, Y)	I. C(MONO-ANALOG)	
	IC402	VC5022 (X, Y)	I. C(MONO-ANALOG)	
	IC901	TA7317P	I. C(MONO-ANALOG)	
		DIODES		
	D102	1SS119	SI. DIODE	
	D131	RD6. 2JSB3	ZENER DIODE	
	D132	RD6. 2JSB3	ZENER DIODE	
	D151	1SS119	SI. DIODE	
	D201	1SS119	SI. DIODE	
	D202	1SS119	SI. DIODE	
	D203	1SS119	SI. DIODE	
	D204	1SS119	SI. DIODE	
	D205	1SS119	SI. DIODE	
	D206	1SS119	SI. DIODE	
	D207	HZ6B1L	ZENER DIODE	
	D208	HZ6B1L	ZENER DIODE	
	D301	1S2076-31	SI. DIODE	
	D302	1S2076-31	SI. DIODE	
	D303	1SS81TD	SI. DIODE	
	D304	1SS81TD	SI. DIODE	
	D305	HZ3ALLTD	ZENER DIODE	
	D306	HZ3ALLTD	ZENER DIODE	
	D307	HZ2BLL	ZENER DIODE	
	D308	HZ2BLL	ZENER DIODE	
	D309	1SS81TD	SI. DIODE	
	D310	1SS81TD	SI. DIODE	
	D311	1S2076-31	SI. DIODE	
	D312	1S2076-31	SI. DIODE	
	D313	1SS81TD	SI. DIODE	
	D314	1SS81TD	SI. DIODE	
	D315	HZ3ALLTD	ZENER DIODE	
	D316	HZ3ALLTD	ZENER DIODE	
	D351	1SS119	SI. DIODE	
	D352	1SS119	SI. DIODE	
	D401	HZ3ALLTD	ZENER DIODE	
	D402	HZ3ALLTD	ZENER DIODE	
	D403	HZ3ALLTD	ZENER DIODE	
	D404	HZ3ALLTD	ZENER DIODE	
	D811	11DF2-FA11	SI. DIODE	
	D812	11DF2-FA11	SI. DIODE	
	D813	11DF2-FA11	SI. DIODE	
	D814	11DF2-FA11	SI. DIODE	
	D815	11DF2-FA11	SI. DIODE	
	D816	11DF2-FA11	SI. DIODE	
	D817	11DF2-FA11	SI. DIODE	
	D818	11DF2-FA11	SI. DIODE	
	D821	HZ18-1L	ZENER DIODE	
	D822	HZ18-1L	ZENER DIODE	
	D823	HZ18-2L	ZENER DIODE	
	D824	HZ18-2L	ZENER DIODE	
	D831	RD22JSB3	ZENER DIODE	
	D832	RD22JSB3	ZENER DIODE	
	D841	HZ11B1LTD	ZENER DIODE	
	D842	HZ11B1LTD	ZENER DIODE	
	D845	RD12JSB3	ZENER DIODE	
	D846	RD12JSB3	ZENER DIODE	

△	Item	Parts Number	Description	Area
	D861	11ES2	SI. DIODE	
	D862	11ES2	SI. DIODE	
	D863	11ES2	SI. DIODE	
	D864	11ES2	SI. DIODE	
	D865	RD20JSB3	ZENER DIODE	
	D866	RD22JSB3	ZENER DIODE	
	D875	RD5. 1JSB3	ZENER DIODE	
	D876	RD6. 2JSB3	ZENER DIODE	
	D901	1SS119	SI. DIODE	
	D904	1SS119	SI. DIODE	
	D931	1SS81TD	SI. DIODE	
	D932	1SS81TD	SI. DIODE	
	D933	1SS81TD	SI. DIODE	
	D934	1SS81TD	SI. DIODE	
	D935	1SS81TD	SI. DIODE	
	D936	1SS81TD	SI. DIODE	
	D981	1SS119	SI. DIODE	
		TRANSISTORS		
	Q131	DTA144ES	DIGITAL TRANSISTOR	
	Q133	DTC143TS	DIGITAL TRANSISTOR	
	Q134	DTA143TSTP	DIGITAL TRANSISTOR	
	Q201	2SK170 (BL)	F. E. T.	
	Q202	2SK170 (BL)	F. E. T.	
	Q203	2SC2240 (BL)	SI. TRANSISTOR	
	Q204	2SC2240 (BL)	SI. TRANSISTOR	
	Q205	2SA970 (GR)	SI. TRANSISTOR	
	Q206	2SA970 (GR)	SI. TRANSISTOR	
	Q207	2SA970 (GR)	SI. TRANSISTOR	
	Q208	2SA970 (GR)	SI. TRANSISTOR	
	Q209	2SC2240 (GR, BL)	SI. TRANSISTOR	
	Q210	2SC2240 (GR, BL)	SI. TRANSISTOR	
	Q211	2SA970 (GR)	SI. TRANSISTOR	
	Q212	2SA970 (GR)	SI. TRANSISTOR	
	Q213	2SC2235 (O, Y)	SI. TRANSISTOR	
	Q214	2SC2235 (O, Y)	SI. TRANSISTOR	
	Q215	2SA965 (Y)	SI. TRANSISTOR	
	Q216	2SA965 (Y)	SI. TRANSISTOR	
	Q217	2SC1775AV (F1)	SI. TRANSISTOR	
	Q218	2SC1775AV (F1)	SI. TRANSISTOR	
	Q301	2SK389 (BL, V)	F. E. T.	
	Q302	2SK389 (BL, V)	F. E. T.	
	Q303	2SC2546 (D, E)	SI. TRANSISTOR	
	Q304	2SC2546 (D, E)	SI. TRANSISTOR	
	Q305	2SC2546 (D, E)	SI. TRANSISTOR	
	Q306	2SC2546 (D, E)	SI. TRANSISTOR	
	Q307	2SA1029 (C, D)	SI. TRANSISTOR	
	Q308	2SA1029 (C, D)	SI. TRANSISTOR	
	Q309	2SA1029 (C, D)	SI. TRANSISTOR	
	Q310	2SA1029 (C, D)	SI. TRANSISTOR	
	Q311	2SA1029 (C, D)	SI. TRANSISTOR	
	Q312	2SA1029 (C, D)	SI. TRANSISTOR	
	Q313	2SA1208 (S)	SI. TRANSISTOR	
	Q314	2SA1208 (S)	SI. TRANSISTOR	
	Q315	2SC2546 (D, E)	SI. TRANSISTOR	
	Q316	2SC2546 (D, E)	SI. TRANSISTOR	
	Q317	2SC2546 (D, E)	SI. TRANSISTOR	
	Q318	2SC2546 (D, E)	SI. TRANSISTOR	
	Q319	2SC2546 (D, E)	SI. TRANSISTOR	
	Q320	2SC2546 (D, E)	SI. TRANSISTOR	
	Q401	2SA1084 (D, E)	SI. TRANSISTOR	
	Q402	2SA1084 (D, E)	SI. TRANSISTOR	
	Q403	2SC2546 (D, E)	SI. TRANSISTOR	
	Q404	2SC2546 (D, E)	SI. TRANSISTOR	
	Q405	2SC458 (C, D)	SI. TRANSISTOR	
	Q406	2SC458 (C, D)	SI. TRANSISTOR	
	Q407	2SA1029 (C, D)	SI. TRANSISTOR	

AX-SD1GD

■ Electrical Parts List (ENH-282)

△	Item	Parts Number	Description	Area
	Q408	2SA1029 (C, D)	SI. TRANSISTOR	
	Q409	2SC1775AV (F1)	SI. TRANSISTOR	
	Q410	2SC1775AV (F1)	SI. TRANSISTOR	
	Q411	2SA872AV (E, F)	SI. TRANSISTOR	
	Q412	2SA872AV (E, F)	SI. TRANSISTOR	
	Q413	2SC1775AV (F1)	SI. TRANSISTOR	
	Q414	2SC1775AV (F1)	SI. TRANSISTOR	
	Q415	2SA872AV (E, F)	SI. TRANSISTOR	
	Q416	2SA872AV (E, F)	SI. TRANSISTOR	
	Q441	2SC3421	SI. TRANSISTOR	
	Q442	2SC3421	SI. TRANSISTOR	
	Q443	2SA1358	SI. TRANSISTOR	
	Q444	2SA1358	SI. TRANSISTOR	
	Q445	2SC3421	SI. TRANSISTOR	
	Q446	2SC3421	SI. TRANSISTOR	
	Q447	2SA1358	SI. TRANSISTOR	
	Q448	2SA1358	SI. TRANSISTOR	
	Q455	2SD1200F (Q, R)	SI. TRANSISTOR	
	Q456	2SD1200F (Q, R)	SI. TRANSISTOR	
	Q471	-----	SEE PAGE 3-14	
	Q472	-----	SEE PAGE 3-14	
	Q473	-----	SEE PAGE 3-14	
	Q474	-----	SEE PAGE 3-14	
	Q701	DTC144ES	DIGITAL TRANSISTOR	
	Q811	2SK246 (BL)	F. E. T.	
	Q812	2SK246 (BL)	F. E. T.	
	Q813	2SA872AV (E, F)	SI. TRANSISTOR	
	Q814	2SC1775AV (F1)	SI. TRANSISTOR	
	Q815	2SB649A (B, C)	SI. TRANSISTOR	
	Q816	2SD669A (B, C)	SI. TRANSISTOR	
	Q817	2SC2546 (D, E)	SI. TRANSISTOR	
	Q818	2SA1084 (D, E)	SI. TRANSISTOR	
	Q819	2SA970 (GR)	SI. TRANSISTOR	
	Q831	2SC2235 (O, Y)	SI. TRANSISTOR	
	Q832	2SA965 (Y)	SI. TRANSISTOR	
	Q833	2SK246 (BL)	F. E. T.	
	Q834	2SK246 (BL)	F. E. T.	
	Q845	2SB941A (P, Q)	SI. TRANSISTOR	
	Q846	2SD1266	SI. TRANSISTOR	
	Q847	2SC2546 (D, E)	SI. TRANSISTOR	
	Q848	2SA1084 (D, E)	SI. TRANSISTOR	
	Q861	2SD1266	SI. TRANSISTOR	
	Q871	2SD1266	SI. TRANSISTOR	
	Q931	2SA970 (GR)	SI. TRANSISTOR	
	Q933	2SC2240 (GR, BL)	SI. TRANSISTOR	
	Q934	2SC2240 (GR, BL)	SI. TRANSISTOR	
	Q935	2SC2240 (GR, BL)	SI. TRANSISTOR	
	Q936	2SC2240 (GR, BL)	SI. TRANSISTOR	
	Q937	2SA970 (GR)	SI. TRANSISTOR	
	Q938	2SA970 (GR)	SI. TRANSISTOR	
	Q981	DTC144ES	DIGITAL TRANSISTOR	
	Q982	DTA143TSTP	DIGITAL TRANSISTOR	
	Q983	DTC144ES	DIGITAL TRANSISTOR	
	Q984	DTA143TSTP	DIGITAL TRANSISTOR	
		CAPACITORS		
	C101	QCBB1HK-101Y	100PF 50V CER. CAP.	
	C102	QCBB1HK-101Y	100PF 50V CER. CAP.	
	C103	QCBB1HK-101Y	100PF 50V CER. CAP.	
	C104	QCBB1HK-101Y	100PF 50V CER. CAP.	
	C105	QCBB1HK-101Y	100PF 50V CER. CAP.	
	C106	QCBB1HK-101Y	100PF 50V CER. CAP.	
	C107	QCBB1HK-101Y	100PF 50V CER. CAP.	
	C108	QCBB1HK-101Y	100PF 50V CER. CAP.	
	C111	QCBB1HK-101Y	100PF 50V CER. CAP.	
	C112	QCBB1HK-101Y	100PF 50V CER. CAP.	
	C113	QCBB1HK-101Y	100PF 50V CER. CAP.	

△	Item	Parts Number	Description	Area
	C114	QCBB1HK-101Y	100PF 50V CER. CAP.	
	C117	QCBB1HK-101Y	100PF 50V CER. CAP.	
	C118	QCBB1HK-101Y	100PF 50V CER. CAP.	
	C120	QCZ0205-155	1.5MF 25V C. CAP.	
	C121	EETB1CM-476E	47MF 16V E. CAP.	
	C122	EETB1CM-476E	47MF 16V E. CAP.	
	C123	EETB1CM-476E	47MF 16V E. CAP.	
	C124	EETB1CM-476E	47MF 16V E. CAP.	
	C125	EETB1CM-476E	47MF 16V E. CAP.	
	C126	EETB1CM-476E	47MF 16V E. CAP.	
	C132	QCBB1HK-221Y	220PF 50V CER. CAP.	
	C133	EETB1CM-106E	10MF 16V E. CAP.	
	C201	QCBB1HK-151	150PF 50V CER. CAP.	
	C202	QCBB1HK-151	150PF 50V CER. CAP.	
	C203	QCS31HJ-221Z	220PF 50V CER. CAP.	
	C204	QCS31HJ-221Z	220PF 50V CER. CAP.	
	C205	QFN31HJ-332Z	3300PF 50V MYLAR CAP.	
	C206	QFN31HJ-332Z	3300PF 50V MYLAR CAP.	
	C207	QFV81HJ-473	0.047MF 50V THIN FILM CAP.	
	C208	QFV81HJ-473	0.047MF 50V THIN FILM CAP.	
	C209	QFN31HJ-103Z	0.01MF 50V MYLAR CAP.	
	C210	QFN31HJ-103Z	0.01MF 50V MYLAR CAP.	
	C211	QFN31HJ-103Z	0.01MF 50V MYLAR CAP.	
	C212	QFN31HJ-103Z	0.01MF 50V MYLAR CAP.	
	C213	QCS31HJ-330Z	33PF 50V CER. CAP.	
	C214	QCS31HJ-330Z	33PF 50V CER. CAP.	
	C215	QCS31HJ-330Z	33PF 50V CER. CAP.	
	C216	QCS31HJ-330Z	33PF 50V CER. CAP.	
	C217	QFN81HJ-682	6800PF 50V METAL MYLAR	
	C218	QFN81HJ-682	6800PF 50V METAL MYLAR	
	C219	QFN31HJ-103Z	0.01MF 50V MYLAR CAP.	
	C220	QFN31HJ-103Z	0.01MF 50V MYLAR CAP.	
	C221	QFP31HG-472	4700PF 50V POLYPROP. FILM	
	C222	QFP31HG-472	4700PF 50V POLYPROP. FILM	
	C223	EET0605-108ZE	1000MF 6.3V E. CAP.	
	C224	EET0605-108ZE	1000MF 6.3V E. CAP.	
	C225	QFV71HJ-564ZM	0.56MF 50V THIN FILM CAP.	
	C226	QFV71HJ-564ZM	0.56MF 50V THIN FILM CAP.	
	C227	QENC1HM-106ZE	10MF 50V NP E. CAP.	
	C228	QENC1HM-106ZE	10MF 50V NP E. CAP.	
	C229	EETB1EM-477E	470MF 25V E. CAP.	
	C230	EETB1EM-477E	470MF 25V E. CAP.	
	C231	QFV81HJ-223	0.022MF 50V THIN FILM CAP.	
	C232	QFV81HJ-223	0.022MF 50V THIN FILM CAP.	
	C237	QFN31HJ-103Z	0.01MF 50V MYLAR CAP.	
	C238	QFN31HJ-103Z	0.01MF 50V MYLAR CAP.	
	C239	QFV81HJ-223	0.022MF 50V THIN FILM CAP.	
	C240	QFV81HJ-223	0.022MF 50V THIN FILM CAP.	
	C241	EETB1HM-226E	22MF 50V E. CAP.	
	C242	EETB1HM-226E	22MF 50V E. CAP.	
	C243	EFF001J-470	47PF 150V FILM MICA CAP.	
	C244	EFF001J-470	47PF 150V FILM MICA CAP.	
	C301	EFF001J-680	68PF 150V FILM MICA CAP.	
	C302	EFF001J-680	68PF 150V FILM MICA CAP.	
	C303	QFV81HJ-473	0.047MF 50V THIN FILM CAP.	
	C304	QFV81HJ-473	0.047MF 50V THIN FILM CAP.	
	C305	EFF001J-680	68PF 150V FILM MICA CAP.	
	C306	EFF001J-680	68PF 150V FILM MICA CAP.	
	C307	EFZ0096-103	0.01MF 630V METAL MYLAR	
	C308	EFZ0096-103	0.01MF 630V METAL MYLAR	
	C309	QFLC1HJ-392	3900PF 50V MYLAR CAP.	
	C310	QFLC1HJ-392	3900PF 50V MYLAR CAP.	
	C311	EFF001J-470	47PF 150V FILM MICA CAP.	
	C312	EFF001J-470	47PF 150V FILM MICA CAP.	
	C351	EFF001J-470	47PF 150V FILM MICA CAP.	
	C352	EFF001J-470	47PF 150V FILM MICA CAP.	

■ Electrical Parts List (ENH-282)

△	Item	Parts Number	Description	Area
	C353	QFV81HJ-224	0.22MF 50V THIN FILM CAP.	
	C354	QFV81HJ-224	0.22MF 50V THIN FILM CAP.	
	C355	QFV81HJ-105	1MF 50V THIN FILM CAP.	
	C356	QFV81HJ-105	1MF 50V THIN FILM CAP.	
	C357	QFV71HJ-153	0.015MF 50V THIN FILM CAP.	
	C358	QFV71HJ-153	0.015MF 50V THIN FILM CAP.	
	C372	QCHB1EZ-223	0.022MF 25V CER. CAP.	
	C401	QFV81HJ-104	0.1MF 50V THIN FILM CAP.	
	C402	QFV81HJ-104	0.1MF 50V THIN FILM CAP.	
	C403	QFV81HJ-104	0.1MF 50V THIN FILM CAP.	
	C404	QFV81HJ-104	0.1MF 50V THIN FILM CAP.	
	C405	EFF001J-330	33P 150V FILM MICA CAP.	
	C406	EFF001J-330	33P 150V FILM MICA CAP.	
	C407	EFF001J-330	33P 150V FILM MICA CAP.	
	C408	EFF001J-330	33P 150V FILM MICA CAP.	
	C409	EFF001J-330	33P 150V FILM MICA CAP.	
	C410	EFF001J-330	33P 150V FILM MICA CAP.	
	C411	EFF001J-330	33P 150V FILM MICA CAP.	
	C412	EFF001J-330	33P 150V FILM MICA CAP.	
	C421	QFV81HJ-103	0.01MF 50V THIN FILM CAP.	
	C422	QFV81HJ-103	0.01MF 50V THIN FILM CAP.	
	C423	QFV81HJ-103	0.01MF 50V THIN FILM CAP.	
	C424	QFV81HJ-103	0.01MF 50V THIN FILM CAP.	
	C425	QCBB1HK-221Y	220PF 50V CER. CAP.	
	C426	QCBB1HK-221Y	220PF 50V CER. CAP.	
	C451	QFN81HJ-472	4700PF 50V MYLAR CAP.	
	C452	QFN81HJ-472	4700PF 50V MYLAR CAP.	
	C811	-----	SEE PAGE 3-14	
	C812	-----	SEE PAGE 3-14	
	C813	QTE1V06-476Z	47MF 35V E. CAP.	
	C814	QTE1V06-476Z	47MF 35V E. CAP.	
	C815	EET3512-476ZE	47MF 35V E. CAP.	
	C816	-----	SEE PAGE 3-14	
	C831	EETB1EM-107E	100MF 25V E. CAP.	
	C832	EETB1EM-107E	100MF 25V E. CAP.	
	C841	EET2508-475ZE	4.7MF 25V E. CAP.	
	C842	EET2508-475ZE	4.7MF 25V E. CAP.	
	C843	EET2508-226ZE	22MF 25V E. CAP.	
	C844	EET2508-226ZE	22MF 25V E. CAP.	
	C861	EETB1JM-477E	470MF 63V E. CAP.	
	C862	EETB1EM-107E	100MF 25V E. CAP.	
	C863	EETC1EM-226ZE	22MF 25V E. CAP.	
	C872	EETB1EM-106E	10MF 25V E. CAP.	
	C873	EETB1AM-107E	100MF 10V E. CAP.	
	C901	EETB1HM-475E	4.7MF 50V E. CAP.	
	C902	QFN81HJ-102	1000PF 50V METAL MYLAR	
	C903	EETB1AM-476E	47MF 10V E. CAP.	
	C904	EETB1AM-476E	47MF 10V E. CAP.	
	C905	EETB1HM-475E	4.7MF 50V E. CAP.	
	C906	QFN81HJ-153	0.015MF 50V MYLAR CAP.	
	C907	EETB1CM-226E	22MF 16V E. CAP.	
	C931	EETB1HM-226E	22MF 50V E. CAP.	
	C971	EFZ0096-473	0.047MF 630V METAL MYLAR	
	C972	EFZ0096-473	0.047MF 630V METAL MYLAR	
	C981	QCZ0205-155	1.5MF 25V C. CAP.	
	C982	QCZ0205-155	1.5MF 25V C. CAP.	
	C991	EFZ0096-473	0.047MF 630V METAL MYLAR	
	C992	EFZ0096-473	0.047MF 630V METAL MYLAR	
	CA101	EMV7122-004Z	SOCKET I.M	
	CA445	EMV5103-005A	PLUG ASSY	
	CA446	EMV5103-005A	PLUG ASSY	
	CA447	EMV5103-005A	PLUG ASSY	
	CA448	EMV5103-005A	PLUG ASSY	
	CAB41	EMV7122-103	SOCKET I.M	
		RESISTORS		
	R101	ERD141J-104SY	100K 1/4W CARBON RES.	

△	Item	Parts Number	Description	Area
	R102	ERD141J-104SY	100K 1/4W CARBON RES.	
	R103	QRD161J-104	100K 1/6W CARBON RES.	
	R104	QRD161J-104	100K 1/6W CARBON RES.	
	R105	QRD161J-104	100K 1/6W CARBON RES.	
	R106	QRD161J-104	100K 1/6W CARBON RES.	
	R107	QRD161J-471	470 1/6W CARBON RES.	
	R108	QRD161J-471	470 1/6W CARBON RES.	
	R111	QRD161J-104	100K 1/6W CARBON RES.	
	R112	QRD161J-104	100K 1/6W CARBON RES.	
	R113	QRD161J-471	470 1/6W CARBON RES.	
	R114	QRD161J-471	470 1/6W CARBON RES.	
	R117	QRD161J-104	100K 1/6W CARBON RES.	
	R118	QRD161J-104	100K 1/6W CARBON RES.	
	R121	QRZ0110-100X	10 1/4W FUSIBLE RES.	
	R122	QRZ0110-100X	10 1/4W FUSIBLE RES.	
	R123	QRD161J-101	100 1/6W CARBON RES.	
	R124	QRD161J-101	100 1/6W CARBON RES.	
	R125	QRD161J-101	100 1/6W CARBON RES.	
	R126	QRD161J-101	100 1/6W CARBON RES.	
	R131	QRD161J-104	100K 1/6W CARBON RES.	
	R132	QRD161J-104	100K 1/6W CARBON RES.	
	R133	QRD161J-104	100K 1/6W CARBON RES.	
	R134	QRD161J-221	220 1/6W CARBON RES.	
	R135	QRD161J-221	220 1/6W CARBON RES.	
	R136	QRD161J-471	470 1/6W CARBON RES.	
	R137	QRD161J-474	470K 1/6W CARBON RES.	
	R151	QRD161J-223	22K 1/6W CARBON RES.	
	R152	QRD161J-223	22K 1/6W CARBON RES.	
	R171	QRD161J-331	330 1/6W CARBON RES.	
	R172	QRD161J-331	330 1/6W CARBON RES.	
	R173	QRD161J-331	330 1/6W CARBON RES.	
	R174	QRD161J-331	330 1/6W CARBON RES.	
	R175	QRD161J-331	330 1/6W CARBON RES.	
	R176	QRD161J-331	330 1/6W CARBON RES.	
	R181	QRD161J-331	330 1/6W CARBON RES.	
	R182	QRD161J-331	330 1/6W CARBON RES.	
	R187	QRD161J-331	330 1/6W CARBON RES.	
	R188	QRD161J-331	330 1/6W CARBON RES.	
	R201	QRD161J-472	4.7K 1/6W CARBON RES.	
	R202	QRD161J-472	4.7K 1/6W CARBON RES.	
	R203	QRD161J-473	47K 1/6W CARBON RES.	
	R204	QRD161J-473	47K 1/6W CARBON RES.	
	R205	QRD161J-101	100 1/6W CARBON RES.	
	R206	QRD161J-101	100 1/6W CARBON RES.	
	R207	QRD161J-100	10 1/6W CARBON RES.	
	R208	QRD161J-100	10 1/6W CARBON RES.	
	R209	QRD167J-511	510 1/6W CARBON RES.	
	R210	QRD167J-511	510 1/6W CARBON RES.	
	R211	QRD161J-220	22 1/6W CARBON RES.	
	R212	QRD161J-220	22 1/6W CARBON RES.	
	R213	QRD161J-393	39K 1/6W CARBON RES.	
	R214	QRD161J-393	39K 1/6W CARBON RES.	
	R215	QRD167J-113	11K 1/6W CARBON RES.	
	R216	QRD167J-113	11K 1/6W CARBON RES.	
△	R217	QRV144F-1201YM	1.2K 1/4W METAL FILM R	
△	R218	QRV144F-1201YM	1.2K 1/4W METAL FILM R	
	R223	QRD161J-271	270 1/6W CARBON RES.	
	R224	QRD161J-271	270 1/6W CARBON RES.	
	R229	QRD167J-111	110 1/6W CARBON RES.	
	R230	QRD167J-111	110 1/6W CARBON RES.	
	R231	QRD161J-302	3K 1/6W CARBON RES.	
	R232	QRD161J-302	3K 1/6W CARBON RES.	
	R233	QRD161J-433	43K 1/6W CARBON RES.	
	R234	QRD161J-433	43K 1/6W CARBON RES.	
	R235	QRD161J-202	2K 1/6W CARBON RES.	
	R236	QRD161J-202	2K 1/6W CARBON RES.	

AX-SD1GD

■ Electrical Parts List (ENH-282)

△	Item	Parts Number	Description	Area
	R237	QRD161J-202	2K 1/6W CARBON RES.	
	R238	QRD161J-202	2K 1/6W CARBON RES.	
	R241	QRD161J-220	22 1/6W CARBON RES.	
	R242	QRD161J-220	22 1/6W CARBON RES.	
	R243	QRD161J-220	22 1/6W CARBON RES.	
	R244	QRD161J-220	22 1/6W CARBON RES.	
	R245	QRD161J-163	16K 1/6W CARBON RES.	
	R246	QRD161J-163	16K 1/6W CARBON RES.	
	R247	QRD161J-164YT	160K 1/6W CARBON RES.	
	R248	QRD161J-164YT	160K 1/6W CARBON RES.	
	R249	QRD161J-273	27K 1/6W CARBON RES.	
	R250	QRD161J-273	27K 1/6W CARBON RES.	
	R251	QRD161J-335YT	3.3M 1/6W CARBON RES.	
	R252	QRD161J-335YT	3.3M 1/6W CARBON RES.	
	R255	ERD004J-110Z	11 1/4W CARBON RES.	
	R256	ERD004J-110Z	11 1/4W CARBON RES.	
	R257	QRD167J-131	130 1/6W CARBON RES.	
	R258	QRD167J-131	130 1/6W CARBON RES.	
	R259	QRD161J-103	10K 1/6W CARBON RES.	
	R260	QRD161J-103	10K 1/6W CARBON RES.	
	R261	QRD161J-102	1K 1/6W CARBON RES.	
	R262	QRD161J-102	1K 1/6W CARBON RES.	
	R263	QRD161J-475	4.7M 1/6W CARBON RES.	
	R264	QRD161J-475	4.7M 1/6W CARBON RES.	
	R265	QRD161J-103	10K 1/6W CARBON RES.	
	R266	QRD161J-103	10K 1/6W CARBON RES.	
	R267	QRD161J-222	2.2K 1/6W CARBON RES.	
	R268	QRD161J-222	2.2K 1/6W CARBON RES.	
	R269	QRD161J-273	27K 1/6W CARBON RES.	
	R270	QRD161J-273	27K 1/6W CARBON RES.	
	R271	QRZ0110-101X	100 1/4W FUSIBLE RES.	
	R272	QRZ0110-101X	100 1/4W FUSIBLE RES.	
	R281	QRD161J-821	820 1/6W CARBON RES.	
	R282	QRD161J-821	820 1/6W CARBON RES.	
	R285	QRD161J-221	220 1/6W CARBON RES.	
	R286	QRD161J-221	220 1/6W CARBON RES.	
	R287	QRD161J-221	220 1/6W CARBON RES.	
	R288	QRD161J-221	220 1/6W CARBON RES.	
	R291	QRD161J-471	470 1/6W CARBON RES.	
	R292	QRD161J-471	470 1/6W CARBON RES.	
	R293	QRD161J-103	10K 1/6W CARBON RES.	
	R294	QRD161J-103	10K 1/6W CARBON RES.	
	R295	QRD161J-103	10K 1/6W CARBON RES.	
	R296	QRD161J-103	10K 1/6W CARBON RES.	
	R301	ERD141J-331S	330 1/4W CARBON RES.	
	R302	ERD141J-331S	330 1/4W CARBON RES.	
	R303	ERD141J-105S	1M 1/4W CARBON RES.	
	R304	ERD141J-105S	1M 1/4W CARBON RES.	
	R307	QRZ0110-331X	330 1/4W FUSIBLE RES.	
	R308	QRZ0110-331X	330 1/4W FUSIBLE RES.	
	R309	QRZ0110-331X	330 1/4W FUSIBLE RES.	
	R310	QRZ0110-331X	330 1/4W FUSIBLE RES.	
	R311	ERD141J-470S	47 1/4W CARBON RES.	
	R312	ERD141J-470S	47 1/4W CARBON RES.	
	R315	ERD141J-562S	5.6K 1/4W CARBON RES.	
	R316	ERD141J-562S	5.6K 1/4W CARBON RES.	
	R317	QRV144F-5602	56K 1/4W CONST. METAL	
	R318	QRV144F-5602	56K 1/4W CONST. METAL	
	R319	ERD141J-681S	680 1/4W CARBON RES.	
	R320	ERD141J-681S	680 1/4W CARBON RES.	
	R321	ERD141J-681S	680 1/4W CARBON RES.	
	R322	ERD141J-681S	680 1/4W CARBON RES.	
	R323	ERD141J-113S	11K 1/4W CARBON RES.	
	R324	ERD141J-113S	11K 1/4W CARBON RES.	
	R325	ERD141J-102S	1K 1/4W CARBON RES.	
	R326	ERD141J-102S	1K 1/4W CARBON RES.	

△	Item	Parts Number	Description	Area
	R327	QRZ0110-470X	47 1/4W FUSIBLE RES.	
	R328	QRZ0110-470X	47 1/4W FUSIBLE RES.	
	R329	ERD141J-331S	330 1/4W CARBON RES.	
	R330	ERD141J-331S	330 1/4W CARBON RES.	
	R331	QRV144F-1802	18K 1/4W CONST. METAL	
	R332	QRV144F-1802	18K 1/4W CONST. METAL	
	R333	QRV144F-1802	18K 1/4W CONST. METAL	
	R334	QRV144F-1802	18K 1/4W CONST. METAL	
	R335	ERD141J-471S	470 1/4W CARBON RES.	
	R336	ERD141J-471S	470 1/4W CARBON RES.	
	R337	QRZ0110-221X	220 1/4W FUSIBLE RES.	
	R338	QRZ0110-221X	220 1/4W FUSIBLE RES.	
	R339	ERD141J-471S	470 1/4W CARBON RES.	
	R340	ERD141J-471S	470 1/4W CARBON RES.	
	R341	QRV144F-6200A	620 1/4W METAL FILM R	
	R342	QRV144F-6200A	620 1/4W METAL FILM R	
	R343	ERD141J-102S	1K 1/4W CARBON RES.	
	R344	ERD141J-102S	1K 1/4W CARBON RES.	
	R345	ERD141J-101S	100 1/4W CARBON RES.	
	R346	ERD141J-101S	100 1/4W CARBON RES.	
	R351	ERD127J-123	12K 1/2W CARBON RES.	
	R352	ERD127J-123	12K 1/2W CARBON RES.	
	R353	ERD127J-301	300 1/2W CARBON RES.	
	R354	ERD127J-301	300 1/2W CARBON RES.	
	R355	QRD161J-512	5.1K 1/6W CARBON RES.	
	R356	QRD161J-512	5.1K 1/6W CARBON RES.	
	R357	QRD161J-512	5.1K 1/6W CARBON RES.	
	R358	QRD161J-512	5.1K 1/6W CARBON RES.	
	R359	ERD141J-681S	680 1/4W CARBON RES.	
	R360	ERD141J-681S	680 1/4W CARBON RES.	
	R361	QRD167J-562	5.6K 1/6W CARBON RES.	
	R362	QRD167J-562	5.6K 1/6W CARBON RES.	
	R363	QRD161J-272	2.7K 1/6W CARBON RES.	
	R364	QRD161J-272	2.7K 1/6W CARBON RES.	
	R365	QRD167J-682	6.8K 1/6W CARBON RES.	
	R366	QRD167J-682	6.8K 1/6W CARBON RES.	
	R401	QRZ0110-122X	1.2K 1/4W FUSIBLE RES.	
	R402	QRZ0110-122X	1.2K 1/4W FUSIBLE RES.	
	R403	QRZ0110-122X	1.2K 1/4W FUSIBLE RES.	
	R404	QRZ0110-122X	1.2K 1/4W FUSIBLE RES.	
	R405	QRV144F-1802	18K 1/4W CONST. METAL	
	R406	QRV144F-1802	18K 1/4W CONST. METAL	
	R407	QRV144F-1802	18K 1/4W CONST. METAL	
	R408	QRV144F-1802	18K 1/4W CONST. METAL	
	R409	ERT-D2WFL351S	350 1/4W NEGATIVE THE	
	R410	ERT-D2WFL351S	350 1/4W NEGATIVE THE	
	R411	ERD141J-182S	1.8K 1/4W CARBON RES.	
	R412	ERD141J-182S	1.8K 1/4W CARBON RES.	
	R413	ERD141J-621S	620 1/4W CARBON RES.	
	R414	ERD141J-621S	620 1/4W CARBON RES.	
	R415	ERD004J-182Z	1.8K 1/4W CARBON RES.	
	R416	ERD004J-182Z	1.8K 1/4W CARBON RES.	
	R417	ERD141J-621S	620 1/4W CARBON RES.	
	R418	ERD141J-621S	620 1/4W CARBON RES.	
	R419	QRZ0110-331X	330 1/4W FUSIBLE RES.	
	R420	QRZ0110-331X	330 1/4W FUSIBLE RES.	
	R421	QRZ0110-331X	330 1/4W FUSIBLE RES.	
	R422	QRZ0110-331X	330 1/4W FUSIBLE RES.	
	R423	QRZ0110-121X	120 1/4W FUSIBLE RES.	
	R424	QRZ0110-121X	120 1/4W FUSIBLE RES.	
	R425	QRZ0110-121X	120 1/4W FUSIBLE RES.	
	R426	QRZ0110-121X	120 1/4W FUSIBLE RES.	
	R427	QRZ0110-121X	120 1/4W FUSIBLE RES.	
	R428	QRZ0110-121X	120 1/4W FUSIBLE RES.	
	R429	QRZ0110-121X	120 1/4W FUSIBLE RES.	
	R430	QRZ0110-121X	120 1/4W FUSIBLE RES.	

■ Electrical Parts List (ENH-282)

△	Item	Parts Number	Description	Area
	R431	ERD004J-471	470 1/4W NETWORK RES.	
	R432	ERD004J-471	470 1/4W NETWORK RES.	
	R433	ERD004J-471	470 1/4W NETWORK RES.	
	R434	ERD004J-471	470 1/4W NETWORK RES.	
	R441	QRZ0110-101X	100 1/4W FUSIBLE RES.	
	R442	QRZ0110-101X	100 1/4W FUSIBLE RES.	
	R443	QRZ0110-101X	100 1/4W FUSIBLE RES.	
	R444	QRZ0110-101X	100 1/4W FUSIBLE RES.	
	R445	QRZ0110-101X	100 1/4W FUSIBLE RES.	
	R446	QRZ0110-101X	100 1/4W FUSIBLE RES.	
	R447	QRZ0110-101X	100 1/4W FUSIBLE RES.	
	R448	QRZ0110-101X	100 1/4W FUSIBLE RES.	
	R449	QRZ0109-3R3X	3.3 1/4W FUSIBLE RES.	
	R450	QRZ0109-3R3X	3.3 1/4W FUSIBLE RES.	
	R451	QRZ0109-6R8X	6.8 1/4W FUSIBLE RES.	
	R452	QRZ0109-6R8X	6.8 1/4W FUSIBLE RES.	
	R453	QRZ0109-6R8X	6.8 1/4W FUSIBLE RES.	
	R454	QRZ0109-6R8X	6.8 1/4W FUSIBLE RES.	
	R455	QRZ0109-3R3X	3.3 1/4W FUSIBLE RES.	
	R456	QRZ0109-3R3X	3.3 1/4W FUSIBLE RES.	
	R471	QRZ0109-3R3X	3.3 1/4W FUSIBLE RES.	
	R472	QRZ0109-3R3X	3.3 1/4W FUSIBLE RES.	
	R473	QRZ0109-3R3X	3.3 1/4W FUSIBLE RES.	
	R474	QRZ0109-3R3X	3.3 1/4W FUSIBLE RES.	
△	R475	ERZ0001-R22	0.22 3W UNF. WIRE WOU	
△	R476	ERZ0001-R22	0.22 3W UNF. WIRE WOU	
△	R477	ERZ0001-R22	0.22 3W UNF. WIRE WOU	
△	R478	ERZ0001-R22	0.22 3W UNF. WIRE WOU	
	R481	QRD161J-181	180 1/6W CARBON RES.	
	R482	QRD161J-181	180 1/6W CARBON RES.	
	R483	QRD161J-681	680 1/6W CARBON RES.	
	R484	QRD161J-681	680 1/6W CARBON RES.	
	R487	QRD161J-151	150 1/6W CARBON RES.	
	R488	QRD161J-151	150 1/6W CARBON RES.	
	R491	ERT-D2WHL202S	2K 1/4W NEGATIVE THE	
	R492	ERT-D2WHL202S	2K 1/4W NEGATIVE THE	
	R811	QRZ0109-2R2X	2.2 1/4W FUSIBLE RES.	
	R812	QRZ0109-2R2X	2.2 1/4W FUSIBLE RES.	
△	R813	QRV144F-8200	1/4W CONST. METAL	
△	R814	QRV144F-8200	1/4W CONST. METAL	
△	R815	QRV144F-4702	47K 1/4W METAL FILM R	
△	R816	QRV144F-4702	47K 1/4W METAL FILM R	
△	R817	QRV144F-4702	47K 1/4W METAL FILM R	
△	R818	QRV144F-4702	47K 1/4W METAL FILM R	
	R819	ERD141J-821S	820 1/4W CARBON RES.	
	R820	ERD141J-821S	820 1/4W CARBON RES.	
	R821	ERD141J-220S	22 1/4W CARBON RES.	
	R822	ERD141J-220S	22 1/4W CARBON RES.	
	R823	QRZ0110-821X	820 1/4W FUSIBLE RES.	
	R824	QRZ0110-821X	820 1/4W FUSIBLE RES.	
	R825	QRZ0110-331X	330 1/4W FUSIBLE RES.	
	R826	QRZ0110-331X	330 1/4W FUSIBLE RES.	
	R827	QRD161J-471	470 1/6W CARBON RES.	
△	R831	QRV144F-8200	1/4W CONST. METAL	
△	R832	QRV144F-8200	1/4W CONST. METAL	
	R833	QRZ0110-100X	10 1/4W FUSIBLE RES.	
	R834	QRZ0110-100X	10 1/4W FUSIBLE RES.	
	R837	QRD161J-473	47K 1/6W CARBON RES.	
	R838	QRD161J-473	47K 1/6W CARBON RES.	
△	R839	QRV144F-4702	47K 1/4W METAL FILM R	
	R841	QRZ0110-100X	10 1/4W FUSIBLE RES.	
	R842	QRZ0110-100X	10 1/4W FUSIBLE RES.	
△	R843	QRV144F-1202	12K 1/4W CONST. METAL	
△	R844	QRV144F-1202	12K 1/4W CONST. METAL	
	R849	QRD161J-821	820 1/6W CARBON RES.	
	R850	QRD161J-821	820 1/6W CARBON RES.	

△	Item	Parts Number	Description	Area
	R851	QRD161J-220	22 1/6W CARBON RES.	
	R852	QRD161J-220	22 1/6W CARBON RES.	
	R861	QRZ0110-100X	10 1/4W FUSIBLE RES.	
△	R862	QRV144F-7501AY	7.5K 1/4W M. FILM	
	R871	QRZ0110-100X	10 1/4W FUSIBLE RES.	
△	R872	QRV144F-1302A	13K 1/4W CONST. METAL	
	R901	QRD161J-473	47K 1/6W CARBON RES.	
	R903	QRD161J-563	56K 1/6W CARBON RES.	
	R904	QRD161J-563	56K 1/6W CARBON RES.	
	R905	QRD161J-103	10K 1/6W CARBON RES.	
	R906	QRD161J-273	27K 1/6W CARBON RES.	
	R907	QRD167J-562	5.6K 1/6W CARBON RES.	
	R908	QRD161J-223	22K 1/6W CARBON RES.	
	R909	QRD161J-273	27K 1/6W CARBON RES.	
	R910	QRD161J-273	27K 1/6W CARBON RES.	
	R911	QRD161J-333	33K 1/6W CARBON RES.	
	R912	QRD161J-563	56K 1/6W CARBON RES.	
	R913	QRD161J-224	220K 1/6W CARBON RES.	
	R914	QRD161J-222	2.2K 1/6W CARBON RES.	
	R915	QRD161J-302	3K 1/6W CARBON RES.	
	R916	QRD161J-392YT	3.9K 1/6W CARBON RES.	
	R917	QRD161J-153	15K 1/6W CARBON RES.	
	R918	QRD161J-472	4.7K 1/6W CARBON RES.	
	R921	QRD161J-473	47K 1/6W CARBON RES.	
	R931	QRD161J-332YTT	3.3K 1/6W CARBON RES.	
	R932	QRD161J-103	10K 1/6W CARBON RES.	
	R933	QRD161J-223	22K 1/6W CARBON RES.	
	R934	QRD161J-223	22K 1/6W CARBON RES.	
	R937	ERD141J-272S	2.7K 1/4W CARBON RES.	
	R938	ERD141J-272S	2.7K 1/4W CARBON RES.	
	R939	ERD141J-153S	15K 1/4W CARBON RES.	
	R940	ERD141J-153S	15K 1/4W CARBON RES.	
	R941	ERD141J-112S	1.1K 1/4W CARBON RES.	
	R942	ERD141J-112S	1.1K 1/4W CARBON RES.	
	R943	ERD141J-112S	1.1K 1/4W CARBON RES.	
	R944	ERD141J-112S	1.1K 1/4W CARBON RES.	
	R945	ERT-D2WFL351S	350 1/4W NEGATIVE THE	
	R946	ERT-D2WFL351S	350 1/4W NEGATIVE THE	
	R947	ERT-D2WFL351S	350 1/4W NEGATIVE THE	
	R948	ERT-D2WFL351S	350 1/4W NEGATIVE THE	
	R949	ERD141J-221S	220 1/4W CARBON RES.	
	R950	ERD141J-221S	220 1/4W CARBON RES.	
	R951	ERD141J-221S	220 1/4W CARBON RES.	
	R952	ERD141J-221S	220 1/4W CARBON RES.	
	R953	QRD161J-201	200 1/6W CARBON RES.	
	R954	QRD161J-201	200 1/6W CARBON RES.	
	R955	QRD161J-201	200 1/6W CARBON RES.	
	R956	QRD161J-201	200 1/6W CARBON RES.	
	R957	QRD161J-100	10 1/6W CARBON RES.	
	R958	QRD161J-100	10 1/6W CARBON RES.	
	R959	QRD161J-100	10 1/6W CARBON RES.	
	R960	QRD161J-100	10 1/6W CARBON RES.	
△	R971	QRX022J-6R8AM	6.8 2W METAL FILM R	
△	R972	QRX022J-6R8AM	6.8 2W METAL FILM R	
	R973	ERD127J-470	47 1/2W CARBON RES.	
	R974	ERD127J-470	47 1/2W CARBON RES.	
△	R977	QRG022J-331AM	330 2W OXIDE METAL	
△	R978	QRG022J-331AM	330 2W OXIDE METAL	
	R979	QRD161J-1R2YTT	1.2 1/6W CARBON RES.	
	R980	QRD161J-1R2YTT	1.2 1/6W CARBON RES.	
△	R981	QRV144F-10R0	10 1/4W M. FILM	
△	R982	QRV144F-10R0	10 1/4W M. FILM	
	RA131	QRB079J-104	100K 1/10W NETWORK RES.	
	VR305	QVDB94Z-E54B	50K VARIABLE RES.	
	VR313	QVPA601-101	100 VARIABLE RES.	
	VR314	QVPA601-101	100 VARIABLE RES.	

AX-SD1GD

■ Electrical Parts List (ENH-282)

△	Item	Parts Number	Description	Area
	VR485	QVPC603-471	470 0.3W VARIABLE RES.	
	VR486	QVPC603-471	470 0.3W VARIABLE RES.	
		OTHERS		
		EMG7331-002	FEEDER CLAMP	
		EMG7331-002U	CONTACT CLIP	
		EMW10505-102	PRINTED BOARD	
		E309307-002	HEAT SINK	
		E3400-431	FELT SPACER	
		E408013-001	P. W. BOARD BRACKET	
		E408022-001	SHIELD PLATE	
		E408023-001	SHIELD PLATE	
		E409546-001	SHIELD TAPE	
		E70306-002	HEAT SINK	
		E70945-H35	HEAT SINK	
		E70945-H35B	HEAT SINK	
		E73525-003	SCREW	
		E73967-016	SPACER	
		E75303-003	SHIELD TAPE	
		E75303-004	SHIELD TAPE	
		E75303-005	SPACER	
		GBSG3008CC	TAPPING SCREW	
		GBSG3010CC	TAPPING SCREW	
		QXTFA00-010	TUBE	
		SBSG3008CC	TAPPING SCREW	
		VYH7653-004	I. C. PROTECTOR	
	J101	EMN00YP-307A	PIN JACK	
	J102	EMN00YP-307A	PIN JACK	
	J103	EMN00TP-412A	PIN JACK	
	J104	EMN00TP-412A	PIN JACK	
	J131	QMS3R90-EA0H	PIN JACK	
	J132	QMS3R90-EA0H	PIN JACK	
	J201	EMN00TV-114A	PIN JACK	
	J202	EMN00TV-114A	PIN JACK	
	K861	ENZ8101-008	INDUCTOR	
	K862	ENZ8101-008	INDUCTOR	
	K903	ENZ8101-008	INDUCTOR	
	L201	EQL4004-101	INDUCTOR	
	L202	EQL4004-101	INDUCTOR	
	L203	EQL4004-101	INDUCTOR	
	L204	EQL4004-101	INDUCTOR	
	L971	EQL0003-1R0	INDUCTOR	
	L972	EQL0003-1R0	INDUCTOR	
	S201	QSP2001-E05A	PUSH SWITCH	
	CB101	EMV7122-004Z	CONNECT TERMINAL	
	CB445	EMV7136-005R	CONNECT TERMINAL	
	CB446	EMV7136-005R	CONNECT TERMINAL	
	CB447	EMV7136-005R	CONNECT TERMINAL	
	CB448	EMV7136-005R	CONNECT TERMINAL	
	CB841	EMV7122-004Z	CONNECT TERMINAL	
	CN201	EMV5111-003	MALE CONNECTOR	
	CN211	EWS243-087	SOCKET WIRE	
	CN301	VMC0041-003	CONNECTOR	
	CN311	EWS243-081	SOCKET WIRE ASSY	
	CN371	EMV5109-007A	MALE CONNECTOR	
	CN372	VMC0075-003	CONNECTOR	
	CN381	EWS267-A913	SOCKET WIRE ASSY	
	CN382	EWS263-A908	SOCKET WIRE ASSY	
	CN441	VMC0107-R06	MALE CONNECTOR	
	CN442	VMC0107-R06	MALE CONNECTOR	
	CN443	VMC0107-R03	CONNECT TERMINAL	
	CN444	VMC0107-R03	CONNECT TERMINAL	
	CN445	EWS215-006	SOCKET WIRE ASSY	
	CN831	EMV7122-103	CONNECT TERMINAL	
	CN832	EMV7122-103	CONNECT TERMINAL	
	CN833	EMV7122-004Z	CONNECT TERMINAL	
	CN842	EMV7122-005	MALE CONNECTOR	

△	Item	Parts Number	Description	Area
	CN901	EMV7122-004Z	CONNECT TERMINAL	
	CN902	EMV7122-004Z	CONNECT TERMINAL	
	CN971	EMV5111-003	MALE CONNECTOR	
	CN972	EMV5111-003	MALE CONNECTOR	
	EP801	EMZ4002-001Z	EARTH PLATE	
	FW101	EWR38B-16LST	FLAT WIRE ASSY	
	FW441	EWR33B-08LST	FLAT WIRE ASSY	
	FW442	EWR33B-08LST	FLAT WIRE ASSY	
	FW443	EWR33B-08LST	FLAT WIRE ASSY	
	FW444	EWR33B-08LST	FLAT WIRE ASSY	
	FW447	EWR33B-08LST	FLAT WIRE ASSY	
	FW448	EWR33B-08LST	FLAT WIRE ASSY	
	FW703	EWR36B-10LST	FLAT WIRE ASSY	
	FW705	EWR38B-10LST	FLAT WIRE ASSY	
	FW831	EWR33B-13LST	FLAT WIRE ASSY	
	FW832	EWR33E-30LST	FLAT WIRE ASSY	
	FW833	EWR34B-16LST	FLAT WIRE ASSY	
	FW841	EWR37B-08LST	FLAT WIRE ASSY	
	FW842	EWR35B-13LST	FLAT WIRE ASSY	
	FW901	EWR34B-08LST	FLAT WIRE ASSY	
	FW902	EWR34B-08LST	FLAT WIRE ASSY	
	FW903	EWR33B-08LST	FLAT WIRE ASSY	
	RY101	ESK5D24-220A	RELAY	
	RY102	ESK5D24-21AF	RELAY	
	RY103	ESK5D24-21AF	RELAY	
	RY351	ESK5D24-220A	RELAY	
	RY352	ESK5D24-220A	RELAY	
	RY971	ESK7D24-2120	RELAY	
	RY972	ESK7D24-2120	RELAY	
	RY973	ESK7D24-2120	RELAY	
	SG101	ENZ2600-001	OUTPUT TRANSFORMER	
	SG102	ENZ2600-001	OUTPUT TRANSFORMER	
	TP471	QMV5004-003K	CONNECT TERMINAL	
	TP472	QMV5004-003K	CONNECT TERMINAL	
	WR053	QWE692-11KR	VINYL WIRE	
	WR054	QWE692-11KR	VINYL WIRE	
	WR101	QWE350-14RR	VINYL WIRE	
	WR103	QWE350-06RR	VINYL WIRE	
	WR104	QWE350-06RR	VINYL WIRE	
	WR201	QWE350-07RR	VINYL WIRE	
	WR301	QWE691-16GR	VINYL WIRE	
	WR441	QWE882-30JR	VINYL WIRE	
	WR442	QWE882-30JR	VINYL WIRE	
	WR443	QWE889-30JR	VINYL WIRE	
	WR444	QWE889-30JR	VINYL WIRE	
	WR445	QWE690-13JR	VINYL WIRE	
	WR446	QWE690-13JR	VINYL WIRE	
	WR801	QWE350-14RR	VINYL WIRE	
	WR802	QWE358-11RR	SHIELD WIRE	
	WR841	QWE350-10RR	SHIELD WIRE	
	WT811	E67764-103	CONNECT TERMINAL	
	WT812	E67764-102	TERMINAL	
	WT901	E67764-102	TERMINAL	
	WT902	E67764-102	TERMINAL	

■ Electrical Parts List (ENB-226)

△	Item	Parts Number	Description	Area
		I. C. S		
	IC701	MN171202K8T	I. C (MICRO-COMPUTER)	
	IC702	PST9140T	I. C (MONO-ANALOG)	
	IC703	GP1U571X	INFRARED DETECT	
		DIODES		
	D701	1SS119	SI. DIODE	
	D702	1SS119	SI. DIODE	
	D703	1SS119	SI. DIODE	
	D704	1SS119	SI. DIODE	
	D705	-----	SEE PAGE 3-14	
	D706	-----	SEE PAGE 3-14	
	D707	-----	SEE PAGE 3-14	
	D708	-----	SEE PAGE 3-14	
	D709	-----	SEE PAGE 3-14	
	D710	-----	SEE PAGE 3-14	
	D711	SLR-342DCA47	L. E. D.	
	D712	SLR-342DCA47	L. E. D.	
	D715	-----	SEE PAGE 3-14	
	D716	-----	SEE PAGE 3-14	
	D717	-----	SEE PAGE 3-14	
	D718	SLA-380LT	L. E. D.	
	D721	SPR-54MVW5F	L. E. D.	
	D722	SLV312YCT31	L. E. D.	
	D723	SLV312YCT31	L. E. D.	
	D724	SLV312YCT31	L. E. D.	
	D725	SLV312YCT31	L. E. D.	
	D726	SLV312YCT31	L. E. D.	
	D727	1SS119	SI. DIODE	
	D741	MTZ6. 2JC	ZENER DIODE	
△	D801	30DL2FA3	DIODE	
△	D802	30DL2FA3	DIODE	
△	D803	30DL2FA3	DIODE	
△	D804	30DL2FA3	DIODE	
△	D805	30DL2FA3	DIODE	
△	D806	30DL2FA3	DIODE	
△	D807	30DL2FA3	DIODE	
△	D808	30DL2FA3	DIODE	
		TRANSISTORS		
	Q702	DTC114YS	DIGITAL TRANSISTOR	
	Q703	2SC1740 (R. S)	SI. TRANSISTOR	
	Q704	DTA124ES	DIGITAL TRANSISTOR	
	Q705	DTC114YS	DIGITAL TRANSISTOR	
	Q706	DTC114YS	DIGITAL TRANSISTOR	
	Q707	DTA143TSTP	DIGITAL TRANSISTOR	
	Q709	DTC144ES	DIGITAL TRANSISTOR	
	Q711	2SD2144S (VW)	SI. TRANSISTOR	
	Q741	2SD1266	SI. TRANSISTOR	
		CAPACITORS		
	C701	QEAD0HZ-479ZB	47000MF 6. 3V E. CAP.	
	C702	EETB0JM-227E	220MF 6. 3V E. CAP.	
	C703	QCZ0205-155	1. 5MF 25V C. CAP.	
	C705	QCVB1CM-103Y	0. 01MF 16V CER. CAP.	
	C706	QEK51HM-225GE	2. 2MF 50V AL E. CAP.	
	C707	QCVB1CM-103Y	0. 01MF 16V CER. CAP.	
	C708	QCGB1HK-102	1000PF 50V CER. CAP.	
	C709	QCZ0205-155	1. 5MF 25V C. CAP.	
	C710	QCZ0205-155	1. 5MF 25V C. CAP.	
	C712	EETB1AM-476E	47MF 10V E. CAP.	
	C713	QCHB1EZ-223	0. 022MF 25V CER. CAP.	
	C714	QCHB1EZ-223	0. 022MF 25V CER. CAP.	
	C721	QCZ0205-155	1. 5MF 25V C. CAP.	
	C722	QCZ0205-155	1. 5MF 25V C. CAP.	
	C731	QCZ0205-155	1. 5MF 25V C. CAP.	
	C741	EETB1CM-106E	10MF 16V E. CAP.	
	C742	EETB1AM-476E	47MF 10V E. CAP.	
	C751	QCZ0205-155	1. 5MF 25V C. CAP.	
	C752	QCZ0205-155	1. 5MF 25V C. CAP.	

△	Item	Parts Number	Description	Area
	C801	EEW5012-628E	6200MF 50V E. CAP.	
	C802	EEW5012-628E	6200MF 50V E. CAP.	
	C803	EEW5012-628E	6200MF 50V E. CAP.	
	C804	EEW5012-628E	6200MF 50V E. CAP.	
	C805	EFZ0096-103	0. 01MF 630V METAL. MYLAR	
	C806	EFZ0096-103	0. 01MF 630V METAL. MYLAR	
	C991	QCBB1HK-471Y	470PF 50V CER. CAP.	
	C992	QCBB1HK-471Y	470PF 50V CER. CAP.	
	CA701	EMV7122-005	OMF MALE CONNECT	
	CA703	EMV7122-103	0. 01MF CONNECT TERM	
	CA705	EMV7122-004Z	0. MF CONNECT TERM	
		RESISTORS		
	R701	QRD161J-221	220 1/6W CARBON RES.	
	R702	QRD161J-102	1K 1/6W CARBON RES.	
	R703	QRD161J-104	100K 1/6W CARBON RES.	
	R704	QRD161J-103	10K 1/6W CARBON RES.	
	R705	QRD161J-103	10K 1/6W CARBON RES.	
	R706	QRD161J-223	22K 1/6W CARBON RES.	
	R707	QRD161J-473	47K 1/6W CARBON RES.	
	R708	QRD161J-473	47K 1/6W CARBON RES.	
	R709	QRD161J-104	100K 1/6W CARBON RES.	
	R712	QRD167J-111	110 1/6W CARBON RES.	
	R712	QRV144F-1100AY	110 1/4W M. FILM	
	R713	QRD167J-111	110 1/6W CARBON RES.	
	R713	QRV144F-1100AY	110 1/4W M. FILM	
	R714	QRD167J-111	110 1/6W CARBON RES.	
	R715	QRD167J-111	110 1/6W CARBON RES.	
	R716	QRD167J-111	110 1/6W CARBON RES.	
	R717	QRD167J-111	110 1/6W CARBON RES.	
	R721	QRD161J-223	22K 1/6W CARBON RES.	
	R722	QRD161J-223	22K 1/6W CARBON RES.	
	R723	QRD161J-223	22K 1/6W CARBON RES.	
	R724	QRD161J-103	10K 1/6W CARBON RES.	
	R725	QRD161J-103	10K 1/6W CARBON RES.	
	R726	QRD167J-111	110 1/6W CARBON RES.	
	R727	QRD167J-111	110 1/6W CARBON RES.	
	R728	QRD167J-111	110 1/6W CARBON RES.	
△	R729	QRV144F-1800	180 1/4W CONST. METAL	
	R730	QRD161J-331	330 1/6W CARBON RES.	
	R731	QRD161J-221	220 1/6W CARBON RES.	
	R732	QRD161J-104	100K 1/6W CARBON RES.	
	R733	QRD161J-104	100K 1/6W CARBON RES.	
	R734	QRD167J-131	130 1/6W CARBON RES.	
	R734	QRV144F-1300AY	130 1/4W M. FILM	
	R735	QRD167J-131	130 1/6W CARBON RES.	
	R735	QRV144F-1300AY	130 1/4W M. FILM	
	R736	QRD167J-131	130 1/6W CARBON RES.	
	R736	QRV144F-1300AY	130 1/4W M. FILM	
	R737	QRD167J-131	130 1/6W CARBON RES.	
	R737	QRV144F-1300AY	130 1/4W M. FILM	
△	R741	QRZ0077-100	10 1/4W FUSIBLE RES.	
△	R742	QRV144F-3601A	3. 6K 1/4W CONST. METAL	
△	R751	QRV144F-2200A	220 1/4W CONST. METAL	
△	R752	QRV144F-2200A	220 1/4W CONST. METAL	
	R753	QRD161J-473	47K 1/6W CARBON RES.	
	R754	QRD161J-472	4. 7K 1/6W CARBON RES.	
		OTHERS		
		EMW10504-102	PRINTED BOARD	
		E306805-047	SPACER	
		E309300-003	INDICATOR HOLDER	
		E73967-016	SPACER	
	J751	QMS6A3A-E42H	HEADPHONE JACK	
	K701	ENZ8101-007	INDUCTOR	
	S701	ESP0001-017	TACT SWITCH	
	S702	ESP0001-017	TACT SWITCH	
	S704	QSR2001-E10A	ROTARY SWITCH	
	S705	QSR2001-E11A	ROTARY SWITCH	

AX-SD1GD

■ Electrical Parts List (ENB-226)

△	Item	Parts Number	Description	Area
	X701	EGX0060-000EM	CERAMIC RESONATOR	
	CB701	EMV7122-005	MALE CONNECTOR	
	CB703	EMV7122-103	CONNECT TERMINAL	
	CB705	EMV7122-004Z	CONNECT TERMINAL	
	CN702	EMV5109-004A	MALE CONNECTOR	
	CN704	EMV7122-103	CONNECT TERMINAL	
	CN712	EWS264-A913	SOCKET WIRE ASSY	
	CN751	EMV7122-103	CONNECT TERMINAL	
	CN903	EMV7122-103	CONNECT TERMINAL	
	EP701	EMZ4002-001Z	EARTH PLATE	
	FW701	EWR3AB-16LST	FLAT WIRE ASSY	
	FW704	EWR33B-08LST	FLAT WIRE ASSY	
	FW751	EWR33B-08LST	FLAT WIRE ASSY	
	WR001	QWE880-44KR	VINYL WIRE	
	WR002	QWE880-44KR	VINYL WIRE	
	WR003	QWE691-22GR	VINYL WIRE	
	WR004	EWT011-168	TERMINAL WIRE	
	WR005	QWE881-40JR	VINYL WIRE	
	WR006	QWE881-40JR	VINYL WIRE	
	WR751	EWT011-158	TERMINAL WIRE	
	WT801	E67764-102	TERMINAL	
	WT802	E67764-102	TERMINAL	
	WT803	E67764-002	TERMINAL PIN	
	WT804	E67764-002	TERMINAL PIN	
	WT805	E67764-102	TERMINAL	
	WT806	E67764-102	TERMINAL	

■ Electrical Parts List (END-101)

△	Item	Parts Number	Description	Area
			CAPACITORS	
△	C001	QCZ9050-472A	4700PF 400V CER. CAP.	
	C973	EFZ0101-103S	0.01MF 100V POLYPROPY. FILM	
	C974	EFZ0101-103S	0.01MF 100V POLYPROPY. FILM	
	C977	EFZ0101-102S	1000PF 100V POLYPROPY. FILM	
	C978	EFZ0101-102S	1000PF 100V POLYPROPY. FILM	
			RESISTORS	
△	R975	QRZ0077-100	10 1/4W FUSIBLE RES.	
△	R976	QRZ0077-100	10 1/4W FUSIBLE RES.	
			OTHERS	
		EMG7331-002	FEEDER CLAMP	
		EMG7331-002U	CONTACT CLIP	
		EMW10599-002A	PRINTED BOARD	
		E73967-016	SPACER	
	TB001	EMZ4001-002Z	TAB	
	TB002	EMZ4001-002Z	TAB	
	WR977	EWT011-078	TERMINAL WIRE ASSY	
	WR978	EWT011-078	TERMINAL WIRE ASSY	

Accessories List

Block No. **M2MM**

△	Item	Parts Number	Parts Name	Q'ty	Description	Area
	1	E30580-2396B	INSTRUCTION BOOK	1		
	2	E309802-001	POLY BAG	1		
	3	RM-SASD1U	WIRE-LESS REMOTE CONTROL	1		
	4	R03BPA-2STSA	DRY CELL	1		
	5	E43486-340A	SAFETY SHEET	1		BS
	6	BT-54003-1	WARRANTY CARD	1		BS
	7	BT-20066A	DISTRIBUTOR LIST	1		BS

= CAUTION =

Item No.	Parts No.	Description
Q471, Q472	PT216	These transistors are controlled by 4 in 1. It is necessary to replace those transistors 4 in 1 at the same time. The parts number listed is the one for "4 in 1".
Q473, Q474		

Item No.	Parts No.	Description
D705~D710	SLR-342YCTE7X6	These diodes are controlled by 6 in 1. It is necessary to replace those diodes 6 in 1 at the same time. The parts number listed is the one for "6 in 1".

Item No.	Parts No.	Description
D715~D717	SLR-342YCA47X3	These diodes are controlled by 3 in 1. It is necessary to replace those diodes 3 in 1 at the same time. The parts number listed is the one for "3 in 1".

Item No.	Parts No.	Description
C811, C812	EEW6319-108E	1000MF E. CAPCITOR
C816	EET3512-476ZE	47MF E. CAPCITOR

* When the above condenser is replaced, it is necessary to order the shield tape below together.

C811, C812	• • • • •	E75303-003	SHIELD TAPE
C816	• • • • •	E75303-004	SHIELD TAPE

AX-SD1GD

Packing Materials and Part Numbers

Block No. **M3MM**

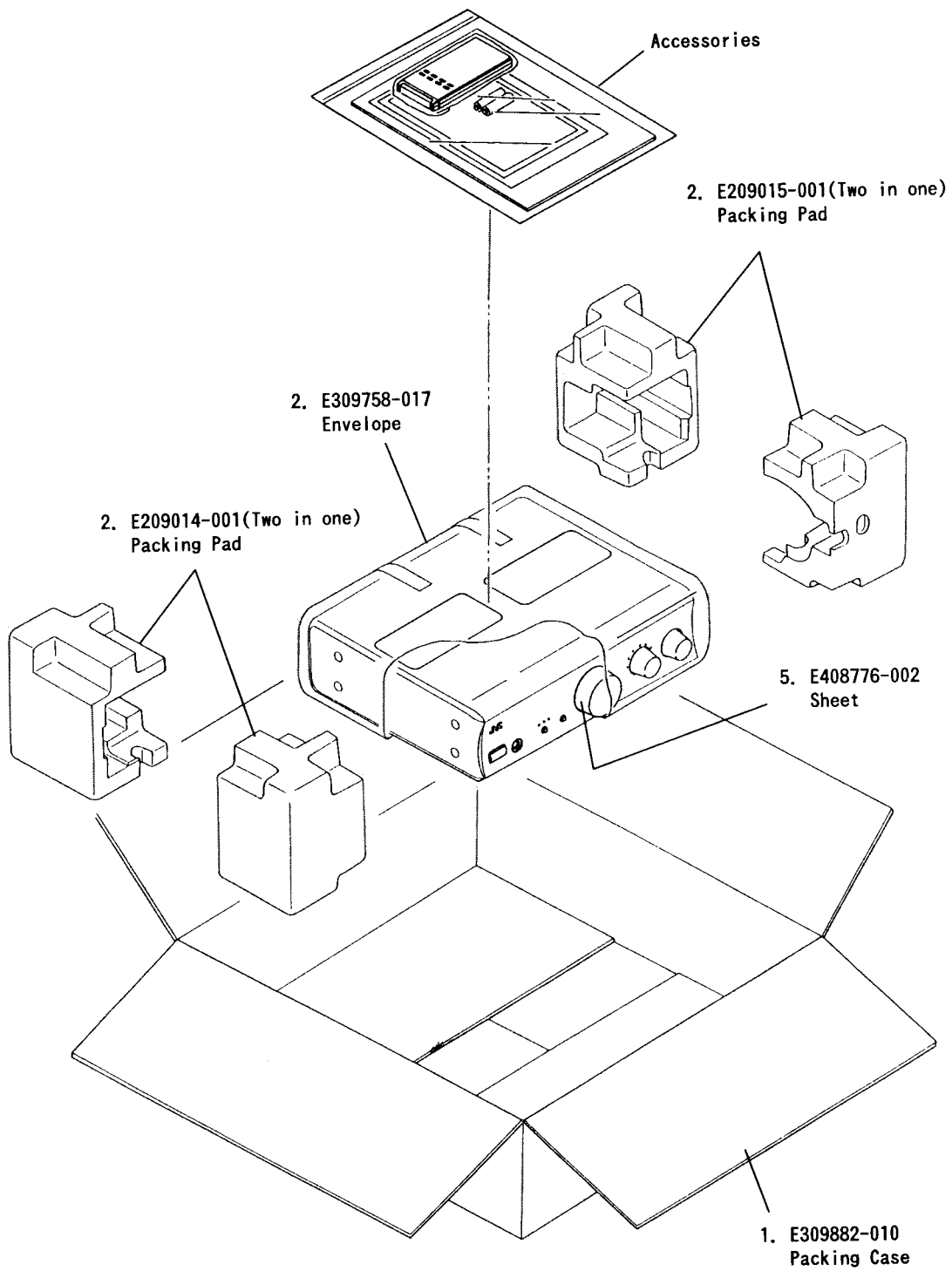

JVC

VICTOR COMPANY OF JAPAN, LIMITED

AUDIO PRODUCT DIVISION, , 1644, SHIMOTSURUMA, YAMATO - SHI, KANAGAWA - KEN, 242, JAPAN

