

JVC

SERVICE MANUAL

DIGITAL REFERENCE INTEGRATED AMPLIFIER

MODEL No. **AX-Z911BK**

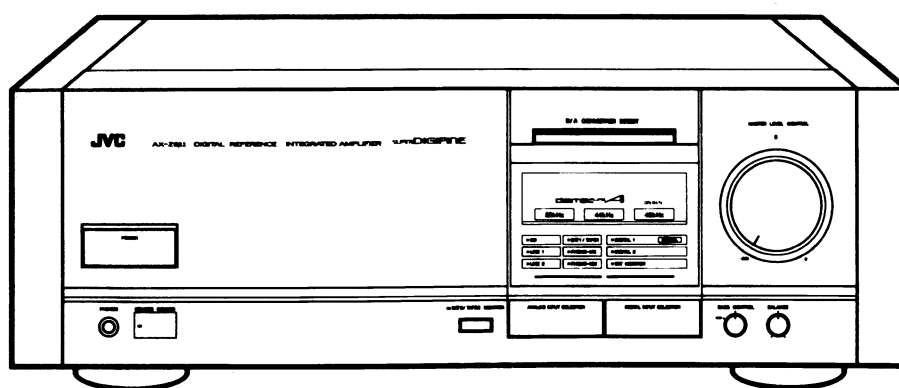

Contents

	Page		
Safety Precautions.....	1-2	Adjustment Procedures	1-33
Instruction Book	1-3	Schematic Diagrams	Insertion
Description of Technology	1-16	Block Diagram	Insertion
Description of Major ICs	1-21	Connection Diagram	Insertion
Internal Block Diagrams of ICs.....	1-27	Trouble shooting	Insertion
Removal Procedures.....	1-32	Parts List.....	Separate Volume Insertion

Safety Precautions

1. The design of this product contains special hardware and many circuits and components specially for safety purposes. For continued protection, no changes should be made to the original design unless authorized in writing by the manufacturer. Replacement parts must be identical to those used in the original circuits. Service should be performed by qualified personnel only.
2. Alterations of the design or circuitry of the product should not be made. Any design alterations of the product should not be made. Any design alterations or additions will void the manufacturer's warranty and will further relieve the manufacturer of responsibility for personal injury or property damage resulting therefrom.
3. Many electrical and mechanical parts in the product have special safety-related characteristics. These characteristics are often not evident from visual inspection nor can the protection afforded by them necessarily be obtained by using replacement components rated for higher voltage, wattage, etc. Replacement parts which have these special safety characteristics are identified in the Parts List of Service Manual. Electrical components having such features are identified by shading on the schematics and by (Δ) on the Parts List in the Service Manual. The use of a substitute replacement which does not have the same safety characteristics as the recommended replacement part shown in the Parts List of Service Manual may create shock, fire, or other hazards.
4. The leads in the products are routed and dressed with ties, clamps, tubings, barriers and the like to be separated from live parts, high temperature parts, moving parts and/or sharp edges for the prevention of electric shock and fire hazard. When service is required, the original lead routing and dress should be observed, and it should be confirmed that they have been returned to normal, after re-assembling.
5. Leakage current check (Electric shock hazard testing)

After re-assembling the product, always perform an isolation check on the exposed metal parts of the product (antenna terminals, knobs, metal cabinet, screw heads, headphone jack, control shafts, etc.) to be sure the product is safe to operate without danger of electrical shock.

Do not use a line isolation transformer during this check.

- Plug the AC line cord directly into the AC outlet. Using a "Leakage Current Tester", measure the leakage current from each exposed metal part of the cabinet, particularly any exposed metal part having a return path to the chassis, to a known good earth ground. Any leakage current must not exceed 0.5 mA AC (r.m.s).

- Alternate check method

Plug the AC line cord directly into the AC outlet. Use an AC voltmeter having 1,000 ohms per volt or more sensitivity in the following manner. Connect a 1,500 Ω 10 W resistor paralleled by a 0.15 μ F AC-type capacitor between an exposed metal part and a known good earth ground.

Measure the AC voltage across the resistor with the AC voltmeter.

Move the resistor connection to each exposed metal part, particularly any exposed metal part having a return path to the chassis, and measure the AC voltage across the resistor. Now, reverse the plug in the AC outlet and repeat each measurement. Any voltage measured must not exceed 0.75 V AC (r.m.s). This corresponds to 0.5 mA AC (r.m.s).

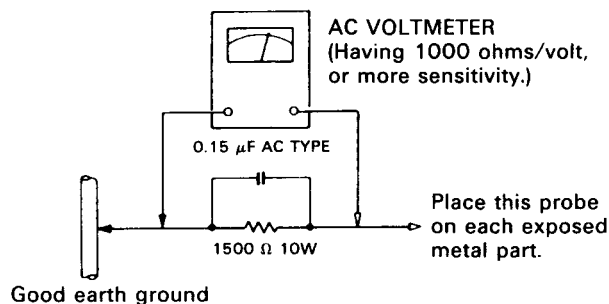

Warning

1. This equipment has been designed and manufactured to meet international safety standards.
2. It is legal responsibility of the repairer to ensure that these safety standards are maintained.
3. Repairs must be made in accordance with the relevant safety standards.
4. It is essential that safety critical components are replaced by approved parts.
5. If mains voltage selector is provided, check setting for local voltage.

SPECIFICATIONS

CIRCUITRY

Preamplifier	: ICL, MC/MM equalizer with EL-FETs in its initial stage
Power amplifier	: "DIGITAL PURE A"/ "Dynamic Super-A" power amplifier with Gm circuit

ALLOVER CHARACTERISTICS

Output power (CD IN → SP. OUT)
100 watts per channel, min. RMS, both channels driven into 8 ohms from 20 Hz to 20 kHz, with no more than 0.003% total harmonic distortion (U.S.A. and Canada only)

105 watts per channel, min. RMS, both channels driven, into 8 ohms at 1 kHz with no more than 0,0005% total harmonic distortion (U.S.A. and Canada only)

100 watts per channel, min. RMS, both channels driven, into 8 ohms at 1 kHz with no more than 0.7% total harmonic distortion (DIN)

120 watts 1 kHz, 4 ohm 0.7% (DIN)

Total harmonic distortion

(CD IN → SP. OUT) : 0.003% (20 Hz — 20 kHz, 8 ohms) at 90 watts

(PHONO IN → SP. OUT at volume —20 dB) : 0.007% (20 Hz — 20 kHz, 8 ohms) at 90 watts

Intermodulation distortion

(CD IN → SP. OUT) : 0.001% (60 Hz : 7 kHz = 4 : 1, 8 ohms) at 90 watts

Power band width

(CD IN → SP. OUT) : 7 Hz — 60 kHz (IHF, 0.02%, 8 ohms both channels driven)

Frequency response : DC to 200 kHz, +0 dB, —3 dB/8Ω (except for W. Germany)
 DC to 120 kHz, +0 dB, —3 dB/8Ω (for W. Germany)

Damping factor : 200 (1 kHz, 8 ohms)

Input terminals

Input sensitivity/impedance (1 kHz)

PHONO (MM) : 2.5 mV/47 k ohms (+6 dB)

PHONO (MC) : 200 μV/470 ohms (+6 dB)

CD, LINE 1, LINE 2, : 400 mV/30 k ohms

DAT 1/TAPE 1

DAT 2/TAPE 2

Signal to noise ratio

PHONO (MM) : 90 dB/72 dB

PHONO (MC) : 74 dB (250 μV input)

CD, LINE 1, LINE 2, : 112 dB/72 dB

DAT 1/TAPE 1

DAT 2/TAPE 2

('66 IHF/DIN)

TECHNISCHE DATEN

SCHALTUNG

Vorverstärker	: Eingangs-Kondensator-entloser-Entzerrer für dynamische/magnetische Tonabnehmer mit extra rauscharmen Feldeffekt-Transistoren im Eingangskreis.
Endverstärker	: Enderstärker "DIGITAL PURE-A"/ Gleichspannung-"Super-A" Endverstärker mit Gm Schaltung.

TECHNISCHE DATEN

Ausgangsleistung (CD IN → Lautsprecher-ausgang)

100 Watt pro Kanal, eff. min. beide Kanäle angesteuert an 8 Ohm, von 20 Hz bis 20 kHz mit nicht mehr als 0,003% Klirrfaktor. (Nur USA und Kanada)

105 Watt pro Kanal, eff. min., beide Kanäle angesteuert an 8 Ohm, bei 1 kHz mit nicht mehr als 0,0005% Klirrfaktor. (Nur USA und Kanada)

100 Watt pro Kanal, eff. min., beide Kanäle angesteuert an 8 Ohm, bei 1 kHz mit nicht mehr als 0,7% Klirrfaktor. (DIN)

120 Watt 1 kHz, 4 Ohm 0,7% (DIN)

Klirrfaktor

(CD IN → Lautsp.-Ausgang) : 0,003% (20 Hz — 20 kHz, 8 Ohm) bei 90 Watt

(Plattenspieler-Eingang (PHONO IN) → Lautsp.-Ausgang bei —20 dB Lautstärke) : 0,007% (20 Hz — 20 kHz, 8 Ohm) bei 90 Watt

Intermodulations-Verzerrung

(CD IN → Lautsp.-Ausgang) : 0,001% (60 Hz : 7 kHz = 4 : 1, 8 Ohm) bei 90 Watt

Leistungsbandbreite

(CD IN → Lautsp.-Ausgang) : 7 Hz — 60 kHz (IHF, 0,02% Klirrfaktor, beide Kanäle an 8 Ohm angesteuert)

Frequenzgang

: 0 Hz bis 200 kHz +0 dB, —3 dB/8Ω (ausgenommen für die BRD)
 0 Hz bis 120 kHz +0 dB, —3 dB/8Ω (für die BRD)

Dämpfungsfaktor : 200 (1 kHz, 8 Ohm)

Eingangs-Anschlüsse

Eingangs-Empfindlichkeit/Impedanz (1 kHz)

PHONO Magnet : 2,5 mV/47 k Ohm (MM) (+6 dB)

PHONO Dynamisch (MC) : 200 μV/470 Ohm (+6 dB)

CD, LINE 1, LINE 2, : 400 mV/30 k Ohm

DAT 1/TAPE 1

DAT 2/TAPE 2

Signal/Rauschabstand

PHONO Magnet (MM) : 90 dB/72 dB

PHONO Dynamisch (MC) Eingang : 74 dB (250 μV)

CD, LINE 1, LINE 2, : 112 dB/72 dB

DAT 1/TAPE 1

DAT 2/TAPE 2

('66 IHF/DIN)

CARACTERISTIQUES TECHNIQUES

CIRCUITS

Préamplificateur	: Entrée sans compensateur égaliseur MC/MM avec transistors à effet de champ EL au stade initial
Amplificateur de puissance	: Amplificateur de puissance "DIGITAL PURE A"/ Amplificateur de puissance "Dynamic Super-A" avec circuit Gm

CARACTERISTIQUES TECHNIQUES D'ENSEMBLE

Puissance de sortie (CD IN → SP. OUT)

100 watts par canal, min. RMS, les deux canaux entraînés à 8 ohms de 20 Hz à 20 kHz, avec moins de 0,003% de distorsion harmonique totale. (Etats-Unis et la Canada seulement)

105 watts par canal, min. RMS, les deux canaux entraînés à 8 ohms à 1 kHz avec moins de 0,0005% de distorsion harmonique totale. (Etats-Unis et la Canada seulement)

100 watts par canal, min. RMS, les deux canaux entraînés, à 8 ohms à 1 kHz avec moins de 0,7% de distorsion harmonique totale. (DIN)

120 watts 1 kHz, 4 ohms 0,7% (DIN)

Distorsion harmonique totale

(CD IN → SP. OUT) : 0,003% (20 Hz — 20 kHz, 8 ohms) à 90 watts

(PHONO IN → SP. OUT à un volume de —20 dB) : 0,007% (20 Hz — 20 kHz, 8 ohms) à 90 watts

Distorsion d'intermodulation

(CD IN → SP. OUT) : 0,001% (60 Hz : 7 kHz = 4 : 1, 8 ohms) à 90 watts

Largeur de gamme puissance : 7 Hz — 60 kHz (IHF, 0,02%, 8 ohms, les deux canaux entraînés)

Réponse en fréquence : DC à 200 kHz, +0 dB, —3 dB/8Ω à l'exception de l'Allemagne de l'Ouest)
 CC à 120 kHz, +0 dB, —3 dB/8Ω pour l'Allemagne de l'Ouest)

Facteur d'amortissement

: 200 (1 kHz, 8 ohms)

Bornes d'entrée

Sensibilité d'entrée/impédance (1 kHz)

PHONO (MM) : 2,5 mV/47 k ohms (+6 dB)

PHONO (MC) : 200 μV/470 ohms (+6 dB)

CD, LINE 1, LINE 2, : 400 mV/30 k ohms

DAT 1/TAPE 1

DAT 2/TAPE 2

Rapports signal/bruit

PHONO (MM) : 90 dB/72 dB

PHONO (MC) : 74 dB (250 μV d'entrée)

CD, LINE 1, LINE 2, : 112 dB/72 dB

DAT 1/TAPE 1

DAT 2/TAPE 2

('66 IHF/DIN)

PHONO (MM) : 80 dB (Rec Out)
 PHONO (MC) : 73 dB (Rec Out)
 CD, LINE 1,
 LINE 2, : 85 dB (Speaker Out)
 DAT 1/TAPE 1
 DAT 2/TAPE 2 ('78 IHF)
 Bass controls : 0 ~ +5 dB (50 Hz,
 MASTER LEVEL
 -30 dB)

DIGITAL INPUT

DIGITAL-1 : -23 ~ -14 dBm
 DIGITAL-2 : 0.5 Vp-p
 DAT REC : 0.5 Vp-p/75 ohm
 DAT PLAY : 0.5 Vp-p

EQUALIZER

PHONO overload capacity
 PHONO (MM) : 100 mV (1 kHz,
 0.007% THD)
 PHONO (MC) : 7 mV (1 kHz, 0.007%
 THD)

PHONO RIAA

deviation : ±0.2 dB
 (20 Hz - 20 kHz)

Total harmonic distortion

PHONO (MM) : 0.003% (at 3 V out-
 put, 20 Hz - 20 kHz)
 PHONO (MC) : 0.003% (at 3 V out-
 put, 20 Hz - 20 kHz)

Recording output

Output level/impedance
 : 400 mV/400 ohms
 (Analog)
 2.0 V/550 ohms
 (Digital)

GENERAL

Dimensions : 475 (W) x 166 (H) x
 442 (D) mm
 (18-3/4" x 6-9/16" x
 17-7/16")
 Weight : 20.0 kg (44.1 lbs)

Design and specifications subject to change
 without notice.

PHONO Magnet : 80 dB (Aufnahme-
 (MM) Ausgang)
 PHONO Dyna- : 73 dB (Aufnahme-
 misch (MC) : Ausgang)
 CD, LINE 1,
 LINE 2, : 85 dB (Lautsprecher-
 Ausgang)
 DAT 1/TAPE 1
 DAT 2/TAPE 2 ('78 IHF)
 Bass-Steuerung : 0 ~ +5 dB (50 Hz,
 MASTER LEVEL
 -30 dB)

DIGITAL INPUT

DIGITAL-1 : -23 ~ -14 dBm
 DIGITAL-2 : 0.5 Vp-p
 DAT REC : 0.5 Vp-p/75 Ohm
 DAT PLAY : 0.5 Vp-p

ENTZERRER

PHONO-Eingangsempfindlichkeit
 PHONO Magnet : 100 mV (1 kHz,
 (MM) 0,007% Klirrfaktor)
 PHONO Dyna- : 7 mV (1 kHz, 0,007%
 misch (MC) : Klirrfaktor)
 PHONO-RIAA-
 Abweichung : ±0,2 dB
 (20 Hz - 20 kHz)

Klirrfaktor

PHONO Magnet : 0,003% (bei 3 V Aus-
 gang, 20 Hz - 20 kHz)
 PHONO Dyna- : 0,003% (bei 3 V Aus-
 gang, 20 Hz - 20 kHz)

Aufnahme-Ausgang

Ausgangspegel/Impedanz
 : 400 mV/400 Ohm
 (Analog)
 2,0 V/550 Ohms
 (Digital)

ALLGEMEIN

Abmessungen : 475 (B) x 166 (H) x
 442 (T)
 Gewicht : 20,0 kg

Technische Änderungen vorbehalten!

PHONO (MM) : 80 dB (sortie d'enre-
 gistrement)
 PHONO (MC) : 73 dB (sortie d'enre-
 gistrement)
 CD, LINE 1,
 LINE 2 : 85 dB (sortie de haut-
 parleur)
 DAT 1/TAPE 1
 DAT 2/TAPE 2 ('78 IHF)
 Commandes de basse : 0 ~ +5 dB (50 Hz,
 MASTER LEVEL
 -30 dB)

ENTREE NUMERIQUE

DIGITAL-1 : -23 ~ -14 dBm
 DIGITAL-2 : 0.5 Vp-p
 DAT REC : 0.5 Vp-p/75 ohms
 DAT PLAY : 0.5 Vp-p

EGALISEUR

Capacité de surcharge PHONO
 PHONO (MM) : 100 mV (1 kHz,
 0,007% DHT)
 PHONO (MC) : 7 mV (1 kHz, 0,007%
 DHT)

Déviaton PHONO

: ±0,2 dB
 (20 Hz - 20 kHz)

Distorsion harmonique totale

PHONO (MM) : 0,003% (à 3 V de sortie,
 20 Hz - 20 kHz)
 PHONO (MC) : 0,003% (à 3 V de sortie,
 20 Hz - 20 kHz)

Sortie d'enregistrement

Niveau de sortie/impédance
 : 400 mV/400 ohms
 (analogique)
 2,0 V/550 ohms
 (numérique)

GENERALES

Dimensions : 475 (L) x 166 (H) x
 442 (P) mm
 Poids : 20,0 kg

Présentation et caractéristiques modifiables sans
 préavis.

POWER SPECIFICATIONS

Areas	Line Voltage & Frequency	Power Consumption
U.S.A. Canada	AC 120 V ~, 60 Hz	550 watts/690 VA
U.K. Australia	AC 240 V ~, 50 Hz	740 watts
Continental Europe Other Areas	AC 220 V ~, 50 Hz AC 110 / 120 / 220 / 240 V ~ selectable, 50/60 Hz	410 watts

SPANUNGSVERSORGUNG UND LEISTUNGS-AUFNAHME

Länder	Netzspannung und Frequenz	Leistungsaufnahme
USA Kanada	120 V ~, 60 Hz	550 Watt/690VA
Großbritannien Australien	240 V ~, 50 Hz	740 Watt
Kontinental-Europa Andere Gebiete	220 V ~, 50 Hz umschaltbar 110 / 120 / 220 / 240 V ~, 50/60 Hz	410 Watt

CARACTERISTIQUES D'ALIMENTATION

Pays	Tension d'alimentation et fréquence	Consommation
Utats-Unis Canada	CA 120 V ~, 60 Hz	550 watts/690VA
Royaume-Uni Australie	CA 240 V ~, 50 Hz	740 watts
Europe Continentale Autres Pays	CA 220 V ~, 50 Hz CA 110 / 120 / 220 / 240 V ~ commutable, 50/60 Hz	410 watts

FRONT PANEL
FRONTPLATTE
PANNEAU AVANT

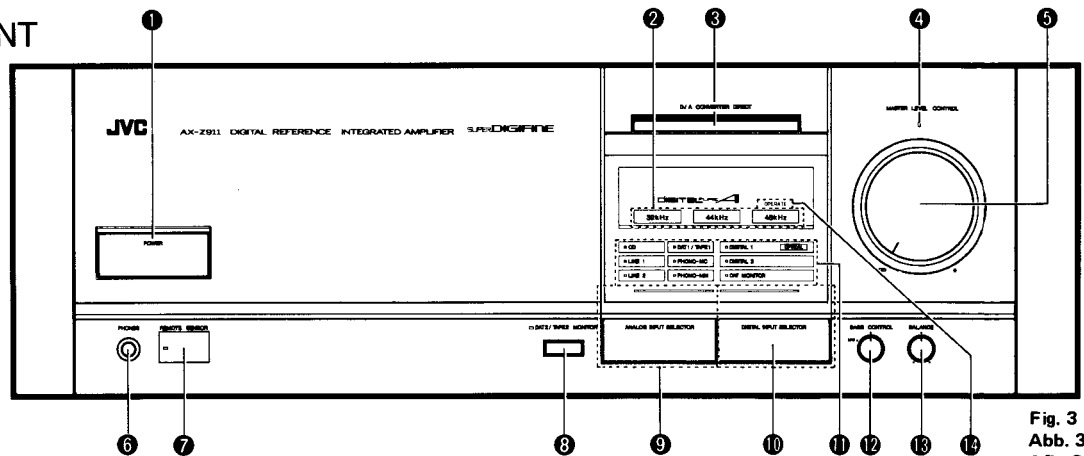

Fig. 3
Abb. 3
Afb. 3

1 POWER

Press this button to turn on the power. When the power button is pressed the indicator will light.

Note:

• Back up circuit

Even if the power is turned off or there is a power failure, the back up circuit will continue to operate and maintain the button settings for about three days. However, after this period has been exceeded the memory circuit will cancel and the button settings will be lost. In this situation press the buttons you want once more.

2 Sampling frequency indicator

In response to a digital signal input a sampling frequency will be displayed in this section. (All the lights turn on when a signal is not being received.)

3 D/A CONVERTER DIRECT

When this button is pressed the indicator will light and a signal from a CD player or some other component connected to the DIGITAL INPUT terminal will input directly into the power amplifier. Very high quality HiFi sound production with DIGITAL PURE A is achieved.

4 Volume indicator

This indicator will blink when the MASTER LEVEL or MUTE buttons on the remote control unit are being operated.

5 MASTER LEVEL CONTROL

This knob is used to adjust the volume of the speakers or headphones.

6 HEADPHONES

The headphones (impedance $6\ \Omega \sim 1\ k\Omega$) can be plugged in here. When the headphones are plugged in, the sound from the speakers will automatically stop.

1 Netzschalter (POWER)

Diese Taste zum Einschalten der Netzspannung betätigen. Bei Drücken der Netzschaltertaste beginnt die Anzeileuchte über der Taste zu blinken und leuchtet dann ununterbrochen, solange das Gerät betriebsbereit ist.

Hinweis:

• Speicherstützschaltung

Auch nach ausschalten der Netzspannung oder bei Stromausfall erhält die Speicherstützschaltung die Werte der Tasteneinstellung etwa drei Tage lang. Danach wird die Speicherstützschaltung den Speicherinhalt allerdings löschen, so daß die Tasteneinstellungen verloren sind. Die gewünschten Tasten sind dann noch einmal zu betätigen.

2 Schaltfrequenzanzeige

Nach Eingang eines Digitalsignals wird die Schaltfrequenz in diesem Feld angezeigt. (Alle Leuchten leuchten auf, solange kein Signal empfangen wird.)

3 D/A CONVERTER DIRECT

Wenn diese Taste gedrückt wird, leuchtet die Anzeige auf und ein Signal vom CD-Player oder einer anderen an die DIGITAL INPUT-Anschlußbuchse angeschlossenen Komponente wird direkt in den Endverstärker gespeist. Durch dieses DIGITAL PURE-A-Verfahren wird HiFi-Klang höchster Qualität erzielt.

4 Lautstärkeanzeige

Diese Anzeige blinkt, wenn die Tasten MASTER LEVEL oder MUTE auf der Fernbedienungseinheit (REMOTE CONTROL) betätigt werden.

5 MASTER LEVEL CONTROL

Dieser Knopf dient der Lautstärkeregelung für die Lautsprecher oder Kopfhörer.

6 Kopfhörer (HEADPHONES)

Hieran werden die Kopfhörer (Impedanz $6\ \Omega \sim 1\ k\Omega$) angeschlossen. Bei Anschluß von Kopfhörern wird der Klang von den Lautsprechern automatisch abgeschaltet.

1 Interrupteur d'alimentation (POWER)

Appuyer sur cette touche pour fournir l'alimentation. Lorsque cette touche est enfoncée, le témoin sur la touche se met à clignoter, et lorsqu'une condition stable est satisfaite, il s'allume.

Remarque:

• Circuit de secours (BACK UP CIRCUIT)

Même si l'alimentation est coupée ou en cas de panne d'électricité, le circuit de secours (BACK UP CIRCUIT) continue à fonctionner et à maintenir le réglage de touches pendant environ trois jours. Cependant, au-delà de cette période, le circuit de mémoire annule le réglage de touches. En ce cas, appuyer de nouveau sur les touches désirées.

2 Indicateur de fréquence de discrimination

En répondant à l'entrée d'un signal numérique, une fréquence de discrimination sera affichée dans cette section. (Toutes les lampes s'allument lorsqu'aucun signal n'est reçu.)

3 D/A CONVERTER DIRECT

Lorsque cette touche est enfoncée, le témoin s'allume, et un signal d'un lecteur de disques compacts ou d'un autre appareil raccordé à la borne d'entrée numérique (DIGITAL INPUT) sera directement envoyé dans l'amplificateur de puissance. La production sonore de très haute fidélité est réalisée avec la touche DIGITAL PURE A.

4 Indicateur de volume

Cet indicateur se met à clignoter lorsque les touches de niveau sonore principal (MASTER LEVEL) ou de réglage silencieux (MUTE) du boîtier de télécommande (REMOTE CONTROL) sont en fonction.

5 Commande de niveau sonore principal (MASTER LEVEL CONTROL)

Cette commande est utilisée pour régler le volume des haut-parleurs ou du casque d'écoute.

6 Prise de casque d'écoute (HEADPHONES)

Le casque d'écoute (impédance de $6\ \Omega$ à $1\ k\Omega$) peut être branché à cette prise. Une fois le casque d'écoute y branché, le son des haut-parleurs s'arrête automatiquement.

7 REMOTE SENSOR

This sensor receives the signal transmitted from the remote control unit. When a signal is being received the indicator will light.

8 DAT 2/TAPE 2 MONITOR

The indicator will light when this button is pressed. It is possible using this button to monitor a DAT deck, cassette deck or SEA graphic equalizer, connected to the DAT 2/TAPE 2 terminals. If the button is pressed again monitoring will stop.

9 ANALOG INPUT SELECTOR

When this button is pressed the areas in the display section above the button will light up in sequence. You can change to different analog signal sources using this button. While the button is being pressed the names of the sources will change in sequence.

→ (CD) → (LINE 1) → (LINE 2) → (DAT 1/TAPE 1) → (PHONO MM or MC)

10 DIGITAL INPUT SELECTOR

When this button is pressed the areas in the display section above the button will light up in sequence. You can change to different digital signal sources, using this button. While the button is being pressed the names of the sources will change in sequence.

→ (DIGITAL 1 (OPTICAL)) → (DIGITAL 2) → (DAT MONITOR + DIGITAL 1) → (DAT MONITOR + DIGITAL 2)

DIGITAL INPUT

A digital signal source connected to the amplifiers DIGITAL INPUT terminal will be processed by the DIGITAL PURE A circuit (For details please read the explanation on page 19.) enabling you to enjoy optimal A CLASS sound production.

11 Source indicator

The name of the source selected by using either the ANALOG INPUT SELECTOR or the DIGITAL INPUT SELECTOR will be displayed in the respective display sections.

12 BASS CONTROL

When music volume is turned down the human ear tends to become less aware of bass sound. This can be compensated for by adjusting the bass control knob so that you can enjoy powerful bass even at low sound level.

13 BALANCE

This knob adjusts the volume balance between the left and right speakers. Normally it is set to the center. (When D/A CONVERTER DIRECT is being used this knob will not operate.)

14 OPERATE indicator

When lit, this indicates that a digital input is being received and the DIGITAL PURE A circuit is operating.

7 Fernbedienungssensor (REMOTE SENSOR)

Dieser Sensor empfängt das von der Fernbedienungseinheit gesendete Signal. Bei Signalempfang leuchtet die Anzeigelampe auf.

8 DAT 2/TAPE 2 MONITOR

Die Anzeigelampe leuchtet auf, wenn diese Taste gedrückt wird. Mit Hilfe der Taste läßt sich der Betrieb eines DA-Tonbandgeräts, eines Kassettendecks oder eines SEA-Graphic-Equalizers mit der Monitor-Funktion kontrollieren, wenn diese Geräte an die DAT 2/TAPE 2-Anschlußbuchsen angeschlossen sind. Bei erneutem Tastendruck wird die Kontrollfunktion ausgeschaltet.

9 Wähler für Analogsignalquellen (ANALOG INPUT SELECTOR)

Bei Tastendruck leuchten die Felder im Display über der Taste der Reihe nach auf. Mit der Taste lassen sich dann verschiedene Analogsignalquellen wählen. Während die Taste gedrückt wird, wechseln die Namen der Signalquellen nacheinander.

→ (CD) → (LINE 1) → (LINE 2) → (DAT 1/TAPE 1) → (PHONO MM oder MC)

10 Wähler für Digitalsignalquellen (DIGITAL INPUT SELECTOR)

Bei Tastendruck leuchten die Felder im Display über der Taste der Reihe nach auf. Mit der Taste lassen sich dann verschiedene Digitalsignalquellen wählen. Während die Taste gedrückt wird, wechseln die Namen der Signalquellen nacheinander.

→ (DIGITAL 1 (OPTICAL)) → (DIGITAL 2) → (DAT MONITOR + DIGITAL 1) → (DAT MONITOR + DIGITAL 2)

Digital-Anschlußklemme (DIGITAL INPUT)

Eine an die DIGITAL INPUT-Anschlußbuchse des Verstärkers angeschlossene digitale Signalquelle wird über den DIGITAL PURE-A-Schaltkreis verarbeitet, was höchste Klangqualität der Verstärkerklasse A sichert. (Einzelheiten hierzu finden Sie auf Seite 19.)

11 Signalquellenanzeige

Der Name der mittels ANALOG INPUT SELECTOR oder DIGITAL INPUT SELECTOR gewählten Signalquelle wird in den jeweiligen Display-Feldern angezeigt.

12 Baßausgleich

Bei niedriger Lautstärke wird das menschliche Ohr tieferen Tönen gegenüber unempfindlich. Ein Ausgleich ist mit Hilfe des Baßreglers möglich, so daß auch bei niedrigen Lautstärkewerten noch kräftige Bässe hörbar sind.

13 BALANCE

Dieser Knopf dient zur Regelung der Lautstärkebalance zwischen den Lautsprechern rechts und links. Normalerweise sollte der Reglerknopf in der Mittenposition stehen. (Bei Verwendung von D/A CONVERTER DIRECT ist die Knopffunktion ausgeschaltet.)

14 OPERATE Anzeige (OPERATE)

Während diese Anzeige aufleuchtet, wird eine Digital-Signalquelle empfangen, und der DIGITAL PURE-A-Schaltkreis ist aktiv.

7 Détecteur de télécommande (REMOTE SENSOR)

Ce détecteur reçoit le signal transmis du boîtier de télécommande. Pendant qu'un signal est reçu, le témoin reste allumé.

8 Contrôle de magnétophone audionumérique 2/bande 2 (DAT 2/TAPE 2)

Le témoin s'allume lorsque cette touche est enfoncée. A l'aide de cette touche, il est possible de contrôler un enregistreur audionumérique, une platine à cassettes ou un égaliseur graphique SEA raccordé aux bornes de magnétophone audionumérique 2/bande 2 (DAT 2/TAPE 2). Si cette touche est de nouveau enfoncée, le contrôle s'arrête.

9 Sélecteur d'entrée analogique (ANALOG INPUT SELECTOR)

Lorsque cette touche est enfoncée, la zone de section d'affichage au-dessus de la touche s'allume en séquence. Il est possible de passer en différentes sources de signal analogique à l'aide de cette touche. Pendant que cette touche est enfoncée, les désignations des sources apparaissent en séquence l'une après l'autre.

→ (CD) → (LINE 1) → (LINE 2) → (DAT 1/TAPE 1) → (PHONO MM ou MC)

10 Sélecteur d'entrée numérique (DIGITAL INPUT SELECTOR)

Lorsque cette touche est enfoncée, la zone de section d'affichage au-dessus de la touche s'allume en séquence. Il est possible de passer en différentes sources de signal numérique à l'aide de cette touche. Pendant que cette touche est enfoncée, les désignations des sources apparaissent en séquence l'une après l'autre.

→ (DIGITAL 1 (OPTICAL)) → (DIGITAL 2) → (DAT MONITOR + DIGITAL 1) → (DAT MONITOR + DIGITAL 2)

Entrée numérique

Une source de signal numérique raccordée à la borne d'entrée numérique (DIGITAL INPUT) de l'amplificateur sera traitée par le circuit DIGITAL PURE A (pour plus de détails, se référer à l'explication de la page 19.), permettant ainsi la production sonore optimale de CLASS A.

11 Indicateur de source

La désignation de la source sélectionnée à l'aide du sélecteur d'entrée analogique (ANALOG INPUT SELECTOR) ou du sélecteur d'entrée numérique (DIGITAL INPUT SELECTOR) sera affichée dans les sections d'affichage respectives.

12 Contrôle de basses (BASS CONTROL)

Lorsque le volume de musique est réduit, les oreilles humaines ont tendance à devenir plus sensibles aux basses. Cela peut être compensé en réglant le bouton de contrôle de basses pour jouir des basses puissantes même au niveau sonore réduit.

13 Balance (BALANCE)

Ce bouton permet de régler la balance entre les hautparleurs de gauche et de droite. Normalement, il est placé sur la position centrale. (Pendant que le bouton D/A CONVERTER DIRECT est utilisé, ce bouton ne fonctionne pas.)

14 Indicateur d'opération (OPERATE)

Lorsqu'il est allumé, ce témoin indique qu'une entrée numérique est en cours de réception et que le circuit DIGITAL PURE A est en fonction.

**HOW TO OPERATE
BEDIENUNG
UTILISATION
BEDIENING
COMO SE OPERA
ANVÄNDNING**

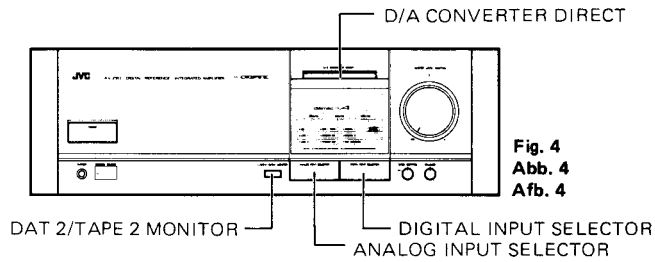

Fig. 4
Abb. 4
Afb. 4

Turn the MASTER LEVEL CONTROL knob down before turning on the power. Connect the tuner and video components to LINE 1 and LINE 2 respectively in accordance with the diagram on page 5 showing connections.

Drehen Sie den MASTER LEVEL CONTROL-Knopf herunter, bevor Sie den Netzstrom einschalten. Schließen Sie den Tuner und die Video-Komponenten an die Buchsen LINE 1 bzw. LINE 2 an, wie im Anschlußdiagramm auf Seite 5 gezeigt.

Abaisser le bouton de contrôle de niveau principal (MASTER LEVEL CONTROL) avant de fournir l'alimentation. Raccorder le syntoniseur et les appareils vidéo à la ligne 1 (LINE 1) et à la ligne 2 (LINE 2) respectivement suivant le diagramme de page 5 indiquant les raccordements.

What do you want to listen to? Was wollen Sie hören? Que voulez-vous écouter?			Names of switches operated Namen der zu betätigenden Schalter Désignation des touches utilisées			
			ANALOG INPUT SELECTOR	DIGITAL INPUT SELECTOR	DATE 2/TAPE 2MONITOR	
RECORD			PHONO	—	OFF	
CD	OUTPUT	OPTICAL DIGITAL	—	DIGITAL 1	OFF	
		COAXIAL DIGITAL	—	DIGITAL 2	OFF	
		ANALOG	CD	—	OFF	
FM/AM Broadcast FM/AM-Rundfunksendungen Emission en FM/AM			LINE 1	—	OFF	
VIDEO (Hi-Fi VIDEO)			LINE 2	—	OFF	
TAPE BAND BANDE	OUTPUT	COAXIAL DIGITAL DAT	—	DAT MONITOR	OFF	
		ANALOG DAT 1/TAPE 1	DAT 1/TAPE 1	—	OFF	
		ANALOG DAT 2/TAPE 2	—	—	ON	

Fig. 5
Abb. 5
Afb. 5

D/A CONVERTER DIRECT switch

When this switch is operated the digital input is received directly by the power amplifier and the balance circuit and source selector circuit are by-passed. The D/A CONVERTER (Digital Analog Converter) output is input directly into MASTER LEVEL CONTROL and very clear high fidelity performance is achieved. Accordingly, when the D/A CONVERTER DIRECT function is ON, ANALOG recording and the balance function will not operate.

Note:

- During the reception of television or FM radio signals, depending on the broadcasting station frequency, noise might appear from digital units such as CD players. In this type of situation, cut off the power to the digital unit.

D/A CONVERTER DIRECT-Schalter

Wenn Sie diesen Schalter betätigen, wird das Digitaleingangssignal direkt vom Endverstärker empfangen, wobei Balance-Schaltkreis und Signalquellenwahl-Schaltkreis umgangen werden. Der D/A CONVERTER-Ausgang (Digital-Analog-Umsetzer) liegt direkt am MASTER LEVEL CONTROL an, wodurch höchste HiFi-Klangqualität gewährleistet ist. Wenn die D/A CONVERTER DIRECT-Funktion eingeschaltet (ON) ist, sind ANALOG-Aufnahmefunktion und Balancereglerfunktion also nicht aktiv.

Hinweis:

- Während des Empfangs von Fernseh- oder UKW-Signalen können – je nach der Frequenz der Signalle – durch Digitalgeräte wie CD-Spieler Geräusche auftreten. In diesem Falle die Stromversorgung zum Digitalgerät abschalten.

Commutateur direct de convertisseur numérique-analogique (D/A CONVERTER)

Lorsque ce commutateur est manqué, l'entrée numérique est directement reçue par l'amplificateur de puissance, et le circuit de balance et le circuit de sélecteur de sources sont ignorés. La sortie de convertisseur numérique-analogique (D/A CONVERTER) est directement entrée dans le contrôle de niveau principal (MASTER LEVEL CONTROL), et la reproduction sonore de très haute fidélité est ainsi réalisée. Par conséquent, lorsque a touche de fonction directe de convertisseur numérique-analogique (D/A CONVERTER DIRECT) est sur la position marche (ON), l'enregistrement analogique (ANALOG) et la commande de balance ne s'effectuent pas.

Remarque:

- Pendant la réception des signaux de la télévision ou de la radio FM, selon la fréquence de la station émettrice, le bruit pourrait se produire des appareils numériques tels que le lecteur de disques compacts. Dans une telle situation, couper l'alimentation de l'appareil numérique.

Recording

1. Choose either an analog or a digital source that can be heard through the speakers. In this situation a tape deck connected to the REC terminal of either DAT 1/TAPE 1 or DAT 2/TAPE 2 can receive a recording signal and recording is possible. Recording level is adjusted from the tape deck, not from the MASTER LEVEL CONTROL. (Please refer to the table on page 15, 17 which shows button settings for various source and recording combinations.)
2. As this amplifier has both DIGITAL and ANALOG type input output terminals for a tape player a variety of combinations are possible.

Aufnahme

1. Verwenden Sie eine Analog- oder Digital-Signalquelle, die über die Lautsprecher zu hören ist. Ein Kassettendeck, das an die REC-Anschlußbuchsen von entweder DAT 1/TAPE 1 oder DAT 2/TAPE 2 angeschlossen ist, kann ein Aufnahmesignal empfangen und ermöglicht damit die Aufnahme. Der Aussteuerungspegel wird vom Kassettendeck her kontrolliert und nicht von MASTER LEVEL CONTROL. (Bitte beziehen Sie sich auf die Tabelle von Seite 15, 17, wo die verschiedenen Knopf- und Tastenstellungen für Signalquellen- und Aufnahmekombinationen aufgeführt sind.)
2. Da der vorliegende Verstärker für das Kassettendeck sowohl über DIGITAL- als auch ANALOG-Ein/Ausgangsbuchsen verfügt, sind vielerlei Zusammenstellungen möglich.

Enregistrement

1. Choisir une source analogique ou numérique qui peut être écoutée à travers les haut-parleurs. Dans ce cas, une platine d'enregistrement raccordée à la borne d'enregistrement (REC) du magnétophone audionumérique 1/bande 1 (DAT 1/TAPE 1) ou du magnétophone audionumérique 2/bande 2 (DAT 2/TAPE 2) peut recevoir un signal d'enregistrement, permettant ainsi l'enregistrement. Le niveau d'enregistrement est réglé depuis la platine d'enregistrement, et non pas depuis la commande de niveau sonore principal (MASTER LEVEL CONTROL). (Se référer à la table de page 15, 17 indiquant le réglage des touches pour diverses combinaisons de source et d'enregistrement.)
2. Cet amplificateur est muni des bornes d'entrée/sortie numérique et analogique pour un lecteur de bandes, et diverses combinaisons sont donc possibles.

What combination of components do you have? Wie sind Ihre Anlagenbauteile zusammengestellt? Quelle combinaison des appareils avez-vous?		Names of switches operated Namen der zu betätigenden Schalter Désignation des touches utilisées			
		DAC DIRECT	ANALOG IN SELECTOR	DIGITAL IN SELECTOR	DAT 2/TAPE 2 MONITOR
PLAY SIDE → RECORDING SIDE WIEDERGABESEITE → AUFNAHMESEITE COTE LECTURE → COTE ENREGISTREMENT					
DIGITAL → DIGITAL					
DIGITAL 1 (OPTICAL)	DAT (COAXIAL)	—	—	DIGITAL 1 → DAT MONITOR	—
DIGITAL 2 (COAXIAL)	DAT (COAXIAL)	—	—	DIGITAL 2 → DAT MONITOR	—
DIGITAL → ANALOG					
DIGITAL 1 (OPTICAL)	DAT 1/TAPE 1	OFF	—	DIGITAL 1	OFF
DIGITAL 1 (OPTICAL)	DAT 2/TAPE 2	OFF	—	DIGITAL 1	* — (Switch ON, to MONITOR) (Einschalten (ON) für MONITOR) (Mettre sur la position marche "ON", vers moniteur)
DIGITAL 2 (COAXIAL)	DAT 1/TAPE 1	OFF	—	DIGITAL 2	OFF
DIGITAL 2 (COAXIAL)	DAT 2/TAPE 2	OFF	—	DIGITAL 2	* — (Switch ON, to MONITOR) (Einschalten (ON) für MONITOR) (Mettre sur la position marche "ON", vers moniteur)
DAT (COAXIAL)	DAT 1/TAPE 1	"You cannot record." "Keine Aufnahme möglich." "L'enregistrement n'est pas possible."			
DAT (COAXIAL)	DAT 2/TAPE 2	OFF	—	DAT MONITOR	* — (Switch ON, to MONITOR) (Einschalten (ON) für MONITOR) (Mettre sur la position marche "ON", vers moniteur)

fig. 7
Abb. 7
Afb. 7

What combination of components do you have? Wie sind Ihre Anlagenbauteile zusammengestellt? Quelle combinaison des appareils avez-vous?		Names of switches operated Namen der zu betätigenden Schalter Désignation des touches utilisées			
		DAC DIRECT	ANALOG IN SELECTOR	DIGITAL IN SELECTOR	DAT 2/TAPE 2 MONITOR
PLAY SIDE → RECORDING SIDE WIEDERGABESEITE → AUFNAHMESEITE COTE LECTURE → COTE ENREGISTREMENT					
ANALOG → ANALOG					
PHONO	DAT 1/TAPE 1	OFF	PHONO	—	OFF
PHONO	DAT 2/TAPE 2	OFF	PHONO	—	(Switch ON, to MONITOR) (Einschalten (ON) für MONITOR) (Mettre sur la position marche "ON", vers moniteur)
CD	DAT 1/TAPE 1	OFF	CD	—	OFF
CD	DAT 2/TAPE 2	OFF	CD	—	(Switch ON, to MONITOR) (Einschalten (ON) für MONITOR) (Mettre sur la position marche "ON", vers moniteur)
LINE 1	DAT 1/TAPE 1	OFF	LINE 1	—	OFF
LINE 1	DAT 2/TAPE 2	OFF	LINE 1	—	(Switch ON, to MONITOR) (Einschalten (ON) für MONITOR) (Mettre sur la position marche "ON", vers moniteur)
LINE 2	DAT 1/TAPE 1	OFF	LINE 2	—	OFF
LINE 2	DAT 2/TAPE 2	OFF	LINE 2	—	(Switch ON, to MONITOR) (Einschalten (ON) für MONITOR) (Mettre sur la position marche "ON", vers moniteur)
DAT 1/TAPE 1	DAT 2/TAPE 2	OFF	DAT 1/TAPE 1	—	(Switch ON, to MONITOR) (Einschalten (ON) für MONITOR) (Mettre sur la position marche "ON", vers moniteur)

Fig. 9
Abb. 9
Afb. 9

Notes:

- DAT which is connected to the DIGITAL terminal from the source of the analog system cannot be recorded.
- Regarding CD/CDV software and digital signals which have a copy prohibit code in the source, a digital recording cannot be made.
- When monitoring a recording to a 3 head type deck the deck should be connected to DAT 2/TAPE 2 terminals and the DAT 2/TAPE 2 MONITOR switch should be ON. Also when recording from a digital source be careful not to turn the MONITOR switch ON and OFF as this will interrupt the recording.
- During synchronized recording, the source is locked to CD or PHONO position to avoid accidental stops or changing to another source.

DIGITAL PURE A

With the built in D/A converter and the special characteristics of digital signals, "signal time base control" becomes easy. Using the special characteristics of the digital signal an optimal A class operation (DIGITAL PURE A) for power amplifier is possible.

Normally, when music is being played, an amplifier operates at an output of several watts and is not required to deliver a large output continuously. With a high performance A CLASS amplifier operating at an average output level a large output is delivered only when there is a peak in the music. This amplifier can be switched to A CLASS amplifier performance, enabling optimum A CLASS operation. The three blocks described below make it possible to use the characteristics of the digital signal to control time so that a large output is delivered precisely when there is a peak in the music. Very economical use of power is achieved and A CLASS amplifier performance becomes a reality.

TIME BASE PROCESSOR ②

Within the MEMORY TIME SHIFT circuit the TIME BASE PROCESSOR is arranged immediately before the D/A CONVERTER and the time base of the input digital signal is shifted.

Hinweise:

- Wenn der DIGITAL-Anschluß mit der Signalquelle eines Analog-Systems verbunden ist, kann kein DAT-Band aufgenommen werden.
- Wenn CD/CDV-Software und digitale Signale mit einer Kopiersperrcodierung versehen sind, kann keine digitale Aufnahme durchgeführt werden.
- Wenn die Aufnahme auf ein 3-TONKOPF-KASSETTENDECK mit der Monitor-Funktion überwacht werden soll, sollte das Kassettendeck an die DAT 2/TAPE 2-Anschlußbuchsen angeschlossen werden und der DAT 2/TAPE 2 MONITOR-Schalter eingeschaltet (ON) sein. Bei Aufnahmen von einer Digitalsignalquelle ist darüber hinaus zu beachten, daß der MONITOR-Schalter nicht ein- und ausgeschaltet wird, da dies die Aufnahme sonst unterbrechen würde.
- Bei Synchro-Aufnahme wird die Signalquelleinstellung für CD oder PHONO verriegelt, so daß unbeabsichtigte Unterbrechungen oder Umschaltung auf andere Signalquellen vermieden werden.

DIGITAL PURE A

Mit Hilfe des eingebauten D/A-Umsetzers und den besonderen Eigenschaften von Digitalsignalen wird "Signalzeitbasis-Steuerung" einfach. Die speziellen Charakteristiken von Digitalsignalen verwirklichen für den Endverstärker die Höchstmögliche Klasse-A-Qualität. Normalerweise liegt die Musikleistung eines Verstärkers nur bei mehreren Watt, der Verstärker braucht also nicht permanent große Ausgangsleistungen aufzubringen. Wenn ein Hochleistungsverstärker der Klasse A bei durchschnittlichem Ausgangspegel betrieben wird, werden hohe Leistungswerte nur bei Spitzenbelastungen abgegeben. Dieser Verstärker läßt sich auf Betriebsleistungen der Klasse A umschalten und ermöglicht dann optimale Leistungen. Die drei nachstehend beschriebenen Schaltungen ermöglichen die Verwendung des Digitalsignals zur Steuerung des Takts, so daß große Leistungen genau bei den Spitzenwerten abgegeben werden. Damit ist äußerst wirtschaftliche Stromaufnahme gegeben, und die Leistungen eines Verstärkers der Klasse A sind verwirklicht.

ZEITBASIS-PROZESSOR ②

Innerhalb des Speichertaktverschiebungs-Schaltkreises liegt der ZEITBASIS-PROZESSOR unmittelbar vor dem D/A-Umsetzer. Er verschiebt die Zeitbasis des Digitaleingangssignals.

Remarques:

- Il est impossible d'effectuer l'enregistrement du magnétophone audionumérique raccordé à la borne numérique (DIGITAL) de la source du système analogique.
- Pour les signaux des logiciels ou numériques du disque compact/disque compact vidéo (CD/CDV) comportant un code d'interdiction de copie dans la source, il est impossible d'effectuer l'enregistrement numérique.
- Lors du contrôle d'un enregistrement pour une platine d'enregistrement à 3 têtes (3 HEAD TAPE DECK), la platine doit être raccordée aux bornes de magnétophone audionumérique 2/bande 2 (DAT 2/TAPE 2), et le commutateur du moniteur de magnétophone audionumérique 2/bande 2 (DAT 2/TAPE 2 MINOTOR) doit être mis sur la position marche (ON). Par ailleurs, lors de l'enregistrement à partir d'une source numérique, veiller à ne pas mettre le commutateur de moniteur (MONITOR) sur la position marche (ON) ou arrêt (OFF). En effet, cela risque d'interrompre l'enregistrement.
- Pendant l'enregistrement synchronisé, la source est verrouillée à la position CD ou PHONO pour éviter des arrêts accidentels ou de changer de source.

DIGITAL PURE A

Grâce au convertisseur numérique-analogique incorporé et aux caractéristiques spéciales des signaux numériques, le "contrôle de base de temps du signal" peut être facilement effectué. En utilisant les caractéristiques spéciales des signaux numériques, il est possible en effet de réaliser le fonctionnement optimal de classe A (DIGITAL PURE A) de l'amplificateur de puissance.

Normalement, au cours de la lecture de la musique, un amplificateur fonctionne à une puissance de sortie de plusieurs watts, et ne nécessite donc pas l'alimentation continue en grande puissance de sortie. Dans le cas du fonctionnement optimal de classe A d'un amplificateur de haute fidélité, une grande puissance de sortie est fournie uniquement lorsqu'il y a une crête dans la musique. Cet amplificateur peut être passé en mode de fonctionnement de classe A, permettant ainsi le fonctionnement optimal de classe A. Les trois passages ci-dessous permettent d'utiliser les caractéristiques des signaux numériques afin de contrôler le temps pour qu'une grande puissance de sortie soit fournie précisément lorsqu'il y a une crête dans la musique. Ainsi, l'utilisation hautement économique de la puissance est devenue possible, et le fonctionnement optimal de classe A de l'amplificateur de haute fidélité est réalisé.

Processeur de base de temps ②

Dans le circuit de décalage de temps (MEMORY TIME SHIFT), le processeur de base de temps (TIME BASE PROCESSOR) est disposé immédiatement avant le convertisseur numérique-analogique (D/A CONVERTER) et la base de temps de l'entrée initiale du signal est décalée.

ANTICIPATED SIGNAL FORMATION / DISCRIMINATING CIRCUIT ⑦

This circuit uses the information received from the signal input to the TIME BASE PROCESSOR, the output signal from the D/A CONVERTER and the output signal from the POWER AMPLIFIER when music is being played to form an anticipated signal. Based on the information received from the digital signals, a supply voltage and an operating point CONTROL SIGNAL are output.

POWER supply circuit with variable source voltage ⑧

The CONTROL SIGNAL selects an optimal power level, to prevent excessive heat generation so that HIGH POWER PURE A operation is possible.

SCHALTKREIS FÜR ERWARTUNGSSIGNALBILDUNG/ANALYSE ⑦

Dieser Schaltkreis verwendet bei der Wiedergabe die Informationen, die der Zeitbasis-Prozessor vom Signaleingang empfangen hat, sowie das Ausgangssignal vom D/A-Umsetzer und das Ausgangssignal vom Endverstärker, um damit ein erwartetes Signal zu bilden. Auf Basis von Informationen, die von den Digitalsignalen empfangen werden, werden Speisespannung und Arbeitspunkt-Steuersignal ausgegeben.

STROMVERSORUNGSSCHALTUNG MIT VARIABLER QUELLENSPANNUNG ⑧

Das Steuersignal wählt einen optimalen Leistungspegel, um übermäßige Erwärmung zu verhüten. Dies ermöglicht PURE-A-Hochleistungsbetrieb.

Formation de signal anticipé/circuit discriminateur ⑦

Ce circuit utilise l'information reçue de l'entrée de signal dans le processeur de base de temps (TIME BASE PROCESSOR), le signal de sortie du convertisseur numérique-analogique (D/A CONVERTOR) et le signal de sortie de l'amplificateur de puissance (POWER AMPLIFIER) pendant que la musique est lue pour former un signal anticipé. Suivant l'information reçue des signaux numériques, une tension d'alimentation et un signal de contrôle (CONTROL SIGNAL) de point de fonctionnement sont sortis.

Circuit d'alimentation avec tension de source variable ⑧

Le signal de contrôle (CONTROL SIGNAL) sélectionne le niveau optimal de puissance afin d'empêcher la production excessive de chaleur pour que le fonctionnement optimal de classe A (HIGH POWER PURE A) soit possible.

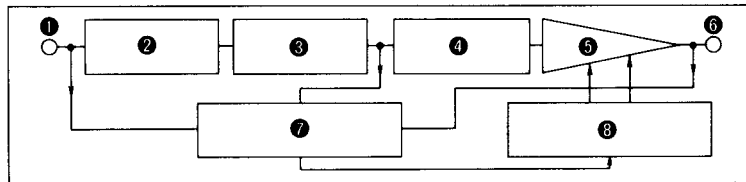

Fig. 11
Abb. 11
Afb. 11

- ① Input
- ② Timer base processor
- ③ D/A converter
- ④ Gain variable
- ⑤ Power amplifier
- ⑥ Output
- ⑦ Anticipated signal formation discriminating circuit
- ⑧ Variable voltage power source

- ① Eingang
- ② Zeitbasis-Prozessor
- ③ Digital/Analog-Umsetzer
- ④ Variable Verstärkung
- ⑤ Endverstärker
- ⑥ Ausgang
- ⑦ Erwartungssignalsbildung-Analyseschaltung
- ⑧ Stromquelle mit Spannungsregelung

- ① Entré
- ② Processeur de base de temps
- ③ Convertisseur numérique/analogique
- ④ Variable de gain
- ⑤ Amplificateur de source
- ⑥ Sortie
- ⑦ Circuit discriminateur de formation de signal anticipé
- ⑧ Alimentation de tension variable

**CONNECTION DIAGRAM
ANSCHLUSSDIAGRAMM
SCHEMA DE RACCORDEMENTS
AANSLUITINGSDIAGRAM
DIAGRAMA DE CONEXIONES
ANSLUTNINGSSCHEMA**

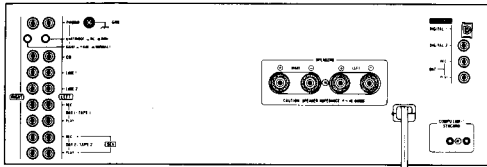

For Continental Europe, the U.K., and Australia
Für Europa, Großbritannien und Australien
Pour l'Europe continentale, le Royaume-Uni et l'Australie
Voor het vasteland van Europa, U.K. en Australië
Para Europa Continental, el Reino Unido y Australia
För kontinentala Europa, Storbritannien och Australien

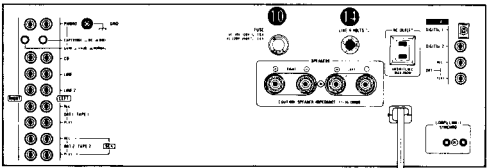

For other areas
Anderen Gebiete
Pour d'autres pays
Voor andere landen
Para otros países
För andra länder

- 1 GND terminal
- 2 PHONO terminals
- 3 Phono selector switch (CARTRIDGE (— MC/ — MM)) — This switch selects between MC and MM type cartridges. When depressed, MC is selected. When returned to the original position MM is selected. Gain (— +6 dB/ — NORMAL) — This switch changes the sensitivity of an equalizer amplifier. When depressed, a gain of +6 dB results.
- 4 CD terminals
- 5 LINE-1 terminals
- 6 LINE-2 terminals
- 7 DAT 1/TAPE 1 terminals
- 8 DAT 2/TAPE 2 SEA terminals
- 9 SPEAKERS terminals
Connect the speaker cords following the figures.
- 10 AC line fuse holder*
- 11 DIGITAL Terminals:
DIGITAL-1: Connect the optical digital output of CD player, etc. Connect the attached optical fiber cable after removing the connector cover.
DIGITAL-2: Connect the coaxial digital output of CD player, etc.
DAT REC: Connect the digital input of DAT deck.
DAT PLAY: Connect the digital output of DAT deck.
Digital coaxial cable: Use 75 ohm coaxial cable with RCA pins at both ends and a length of about 1 meter to connect the DIGITAL-2 and DAT terminals.
- 12 AC OUTLETS**
UNSWITCHED AC outlets

CD player
CD-Player
Lecteur de disques compacts
Kompakt diskspeler
Tocadiscos compacto
CD-spelare

Tuner
Tuner
Synthéiseur
Tuner
Sintonizador
Tuner

Hi-Fi VCR
Hi-Fi-Videorecorder
Magnétoscope de haute fidélité
Hi-Fi videorecorder
Grabdor de videocassettes
Hi-fi-videobandspelare

Tape deck
Kassetendeck
Platine d'enregistrement
Cassetdeck
Magnetofono
Kassett bandspelare

DAT deck
DA-Tonbandgerät
Enregistreur audionumérique
DAT digital deck
Magnetofono digital
Digitalkassettdäck

SEA graphic equalizer
Graphischen SEA Equalizers
Égaliseur graphique SEA
SEA grafische equalizer
Equalizador gráfico SEA
SEA grafisk equalizer

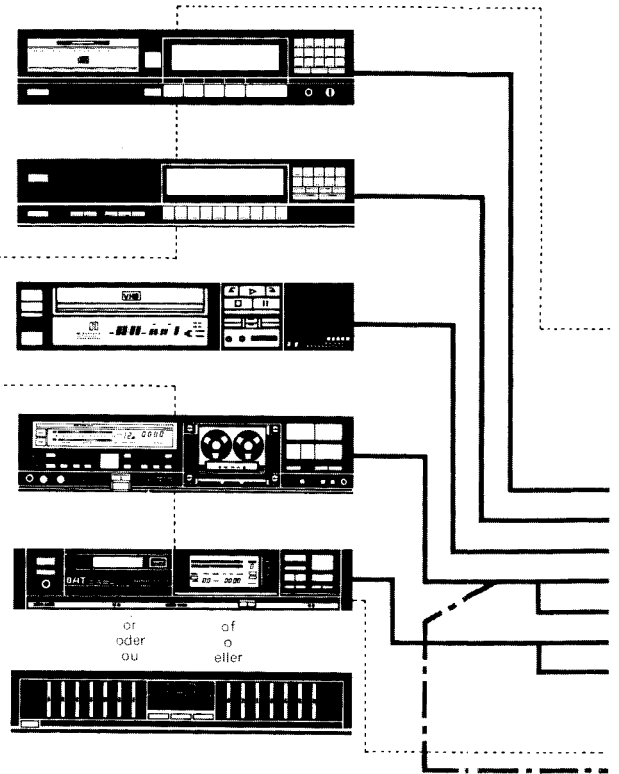

- 1 GND-Anschlußklemme
- 2 PHONO-Anschlußbuchsen
- 3 Phono-Wählschalter (CARTRIDGE (— MC/ — MM)) — Dieser Schalter dient zur Wahl zwischen Tonabnehmern des Typs MC und MM. Bei Tastendruck wird MC gewählt. Wenn die Taste wieder in der Ausgangsstellung ist, ist MM gewählt.
Gain (Verstärkung) (— +6 dB/ — NORMAL) — Dieser Schalter ändert die Ansprechempfindlichkeit eines Entzerrer-Verstärkers. Bei Tastendruck erfolgt eine Verstärkung von +6 dB.
- 4 CD-Anschlußbuchsen
- 5 LINE-1 Anschlußbuchsen
- 6 LINE-2 Anschlußbuchsen
- 7 DAT 1/TAPE 1-Anschlußbuchsen
- 8 DAT 2/TAPE 2-SEA-Anschlußbuchsen
- 9 SPEAKERS-Anschlußbuchsen
- 10 Sicherungsfach*
- 11 DIGITAL-Anschlußbuchse:
DIGITAL-1: Zum Anschluß an den opto-Digitalausgang des CD-Players, usw. Das mitgelieferte faseroptische Kabel nach dem Entfernen der Steckerabdeckung anschließen.
DIGITAL-2: Zum Anschluß an den Koaxial-Digitalausgang des CD-Players, usw.
DAT REC: Zum Anschluß an den Digital-eingang des DA-Kassettengeräts.
DAT PLAY: Zum Anschluß an den Digitalausgang des DA-Kassettengeräts.
Digitales Koaxialkabel: Verwenden Sie ein 75-Ohm-Koaxialkabel mit RCA-Stiften an beiden Enden und einer Länge von 1 meter für den Anschluß der DIGITAL-2-Buchsen an die DAT-Buchsen.
- 12 Netzausgänge (AC OUTLETS)**
Ungeschaltete Netzausgänge (UNSWITCHED AC)

- 1 Borne de mise à la terre (GND)
- 2 Bornes de platine tourne-disque (PHONO)
- 3 Commutateur de sélecteur de platine tourne-disque (PHONO) (CARTRIDGE (— MC/ — MM)) — Ce commutateur permet la sélection entre les cellules de type MC et MM. Lorsque ce commutateur est enfoncé, MC est sélectionné. Lorsqu'il est remis sur sa position originale, MM est sélectionné.
Gain (— +6 dB/ — NORMAL) — Ce commutateur permet de changer la sensibilité d'un amplificateur d'égaliseur. Lorsque ce commutateur est enfoncé, il en résulte un gain de +6 dB.
- 4 Bornes de lecteur de disque audionumérique
- 5 Bornes de ligne-1 (LINE-1)
- 6 Bornes de ligne-2 (LINE-2)
- 7 Bornes de magnétophone audionumérique 1/ bande 1 (DAT 1/TAPE 1)
- 8 Bornes de magnétophone audionumérique 2/ bande 2 SEA (DAT 1/TAPE 1 SEA)
- 9 Bornes de haut-parleurs (SPEAKERS)
Raccorder les câbles de haut-parleurs selon les illustrations.
- 10 Compartiment de fusible de ligne CA**
- 11 Borne numérique (DIGITAL) Terminal:
Numérique-1 (DIGITAL-1): Raccorde la sortie numérique optique du lecteur de disques compacts, etc.
Raccorde le câble de fibre optique fourni après avoir enlevé le couvercle de connecteur.
Numérique-2 (DIGITAL-2): Raccorde la sortie numérique coaxiale du lecteur de disques compacts, etc.
Enregistrement de magnétophone audionumérique (DAT REC): Raccorde l'entrée numérique de l'enregistreur audionumérique.
Lecture de magnétophone audionumérique (DAT PLAY): Raccorde la sortie numérique de l'enregistreur audionumérique.
Câble coaxial numérique: Utiliser un câble coaxial avec des broches RCA aux deux extrémités et une longueur de 1 mètre pour connecter les bornes DIGITAL 2 et DAT.
- 12 Prises CA (AC OUTLETS)**
Prises CA non commutées (UNSWITCHED AC)

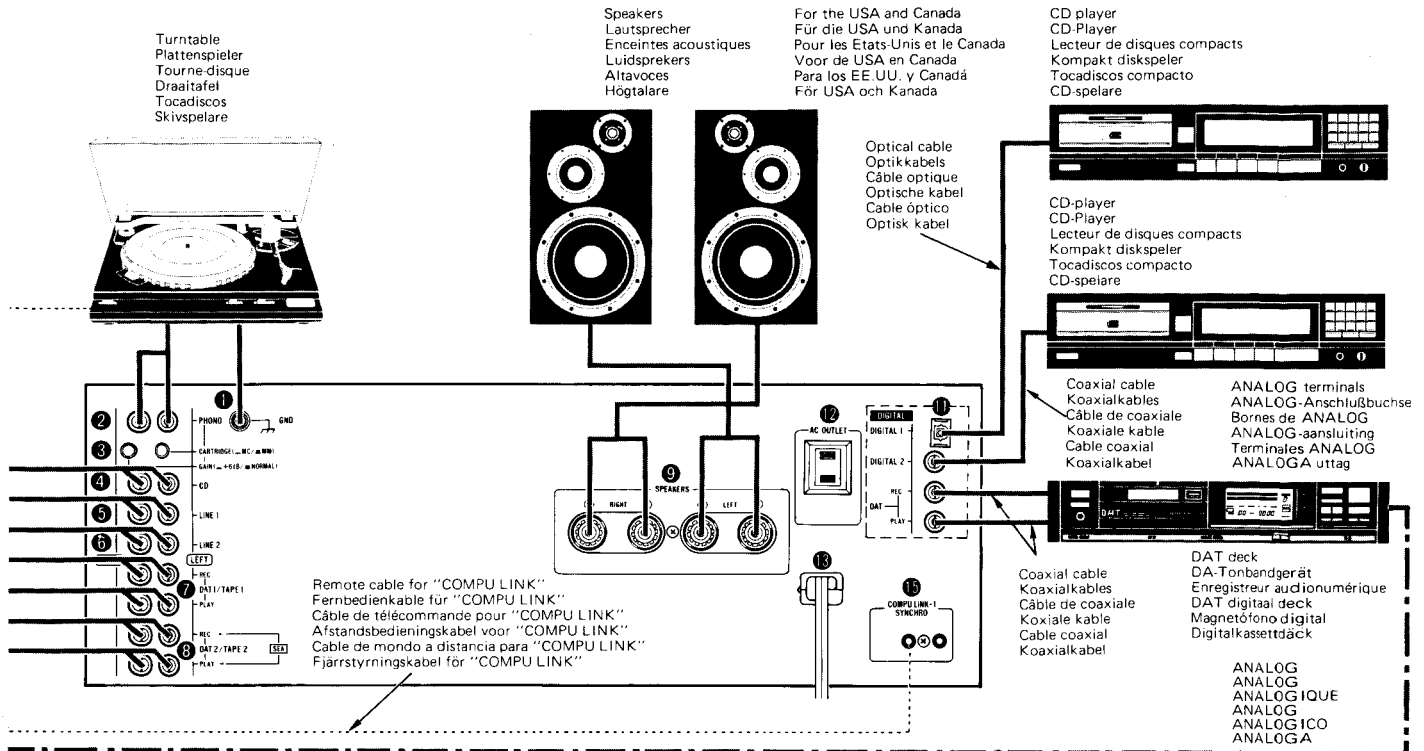

- 1 Aardaansluiting (GND)
- 2 Platenspeleraansluitingen (PHONO)
- 3 Platenspelerelement-keuzeschakelaar (CARTRIDGE (— MC/ — MM)) — Stel deze schakelaar in overeenkomstig het gebruikte platenspelerelement (MC of MM). Druk de schakelaar in voor MC en zet de schakelaar in de vrije stand voor MM.
Versterking (— +6 dB/ — NORMAL) — Deze schakelaar verandert de gevoeligheid van de equalizer-versterker. Bij het indrukken van de schakelaar wordt een versterking van +6 dB verkregen.
- 4 CD-aansluitingen (CD)
- 5 Lijningang 1 (LINE 1)
- 6 Lijningang 2 (LINE 2)
- 7 DAT-1/tape-1 aansluitingen (DAT 1/TAPE 1)
- 8 DAT-2/tape-2 aansluitingen (DAT 2/TAPE 2 SEA)
- 9 Luidsprekeraansluitingen (SPEAKERS)
Sluit hierop de luidsprekersnoeren aan zoals aangegeven in de afbeelding.
- 10 Zekeringhouder*
- 11 DIGITAL-aansluiting:
DIGITAL-1: Verbind deze met de optische digitale uitgang van de CD-speler, enz. Verbind de toegevoegde optische kabel na het verwijderen van de verbinding-beschermer.
DIGITAL-2: Verbind deze met de coaxiale digitale uitgang van de CD-speler, enz.
DAT REC: Verbind deze met de digitale ingang van het DAT-deck.
DAT PLAY: Verbind deze met de digitale uitgang van het DAT-deck.
Digitale koaxkabel: Gebruik een 1 meter lange 75-Ohm koaxkabel met RCA-pennen aan beide uiteinden en sluit de kabel op de DIGITAL-2 en DAT aansluitingen aan.
- 12 Netuitgangen (AC OUTLETS)**
Ongeschakelde netuitgangen (UNSWITCHED AC)

- 1 Terminal GND
- 2 Terminales PHONO
- 3 Selector fonográfico (CARTRIDGE (— MC/ — MM)) — Este interruptor selecciona ya sea la cápsula tipo MC o la tipo MM. Cuando se oprime, se selecciona MC. Cuando se retorna a la posición original, se selecciona MM.
Ganancia (— +6 dB/ — NORMAL) — Este interruptor cambia la sensibilidad de un amplificador equalizador. Cuando se oprime, resulta una ganancia de +6 dB.
- 4 Terminales CD
- 5 Terminales LINE 1
- 6 Terminales LINE 2
- 7 Terminales DAT 1/TAPE 1
- 8 Terminales SEA DAT 2/TAPE 2
- 9 Terminales SPEAKERS
Conecte los cables de los altavoces de acuerdo con las figuras.
- 10 Portafusible de CA*
- 11 Terminales DIGITAL:
Terminal DIGITAL-1: Conectan la salida óptica digital del reproductor de discos compactos, etc.
Conecta el cable de fibra óptica que se adjunta después de retirar la tapa del conector.
Terminal DIGITAL-2: Conecta la salida coaxial digital del reproductor de discos compactos, etc.
Terminal DAT REC: Conecta la entrada digital del magnetófono digital.
Terminal DAT PLAY: Conecta la salida digital del magnetófono digital.
Cable coaxial digital: Para conectar los terminales DIGITAL-2 y DAT, emplee un cable coaxial de 75 ohmios con conectores RCA en ambos extremos, y de 1 metro de longitud.
- 12 Tomas de CA (AC OUTLETS)**
(UNSWITCHED AC) Tomas de CA sin conmutador

- 1 Jorduttag (GND)
- 2 Skivspelaringångar (PHONO)
- 3 CARTRIDGE (— MC/ — MM) — Används för omkoppling mellan MC- eller MM pickup. När MC pickup används skall omkopplaren vara intryckt och när MM pickup används skall omkopplaren vara intryckt.
Förstärkning (— +6 dB/ — NORMAL) — Denna omkopplare ändrar equalizer förstärkarens känslighet. När den trycks in resulterar detta i +6 dB förstärkning.
- 4 CD-ingångar (CD)
- 5 Linjeingång 1 (LINE-1)
- 6 Linjeingång 2 (LINE-2)
- 7 DAT 1/TAPE 1-uttag
- 8 DAT 2/TAPE 2 SEA-uttag
- 9 Högtalaruttag (SPEAKERS)
Anslut högtalarledningarna såsom bilderna visar.
- 10 Hållare för nätspanningssäkring*
- 11 DIGITAL-uttag:
DIGITAL-1: För anslutning av CD-spelarens optiska digitalutgång, etc.
Anslut den medföljande optiska fiberkabeln hit när du har tagits bort skyddslocket över uttaget.
DIGITAL-2: För anslutning av CD-spelarens coaxiala digitalutgång, etc.
DAT REC: För anslutning av digitalkassettdäckets (DAT) digitalingång.
DAT PLAY: För anslutning av digitalkassettdäckets (DAT) digitalutgång.
Digital koaxialkabel: Använd en ca. en meter lång 75-ohms koaxial kabel med RCA-stiftkontakt på kabelns bägge ändar för att ansluta kopplingen DIGITAL-2 till DAT-kopplingen.
- 12 Växelströmsuttag (AC OUTLETS)**
Ej avstängningsbara växelströmsuttag (UNSWITCHED AC)

- Ⓛ Power cord
- Ⓛ AC voltage selector*
When this equipment is used in an area where the supply voltage is different from the preset voltage, reset the voltage selector to the correct position. Change the fuse to the designated capacity.
- Ⓛ COMPU LINK-1/SYNCHRO terminals
Connect to units provided with a COMPU LINK-1/SYNCHRO terminal to let the COMPU LINK control system function.

Notes:

1. Switch the power off when connecting any component.
2. Connect source components with left and right channels connected correctly. Reversed channels may degrade the stereo effect.
3. Connect speakers with correct polarity; (+) to (+) and (-) to (-). Reversed polarity will degrade the stereo effect.
4. Connect plugs or wires firmly. Poor contact may result in hum or damage the unit.
5. Do not connect equipment requiring more than the rated power to the AC outlets on the rear panel.
6. The UNSWITCHED AC outlets are not switched off when the front panel power switch is switched off.**
7. If your turntable has a separate ground lead, connect it to the GND terminal.
8. Use speakers with the correct impedance. This amplifier is for use with speakers with an impedance from 4 to 16 ohms.
9. Connection of attached digital signal cable
Before connecting the optical cable to the DIGITAL 1 optical input terminal remove the cover from the terminal.
Since optical cable is made of plastic or glass material be careful not to bend sharply.
Connect the digital signal output cable ONLY to the digital terminal.
10. When a unit is connected to the digital terminals of the present amplifier, it is not operated by COMPU LINK. (This can prevent accidental operation.)
11. When connected by COMPU LINK the TAPE DECK should be connected to the corresponding DAT 1/TAPE 1 terminals on the amplifier and the DAT DECK should be connected to the corresponding DAT 2/TAPE 2 terminals. When both the analog and digital terminals of DAT DECK are connected the analog terminal of the DAT DECK should be connected to the DAT 1/TAPE 1 terminal of the amplifier in order to prevent oscillation. Furthermore, the TAPE DECK should be connected to the DAT 2/TAPE 2 terminals of the amplifier. In this situation the corresponding COMPU LINK connections will be different. Don't connect COMPU LINK cables to the TAPE DECK or the DAT DECK.

* Not provided on units for the U.S.A., Canada, Continental Europe, U.K. and Australia.

** Not provided on units for Continental Europe, the United Kingdom and Australia.

- Ⓛ Netzkabel
- Ⓛ Netzspannungswähler*
Wenn die voreingestellte Netzspannung an diesem Gerät nicht mit der tatsächlich vorhandenen übereinstimmt, den Spannungswähler auf den erforderlichen Wert einstellen. Die Sicherung mit der vorgeschriebenen Leistung austauschen.
- Ⓛ COMPU LINK-1/SYNCHRO Anschlußbuchsen
An Geräte anschließen, die mit einer COMPU LINK-1/SYNCHRO-Anschlußbuchse ausgestattet sind, um somit die COMPU LINK-Steuerung in Funktion treten zu lassen.

Hinweise:

1. Vor Anschluß jeglicher Komponenten ist die Netzspannung auszuschalten.
2. Die Signalquellen so anschließen, daß die rechten und linken Lautsprecherkanäle phasenrichtigen angeschlossen haben. Phasenverkehrt angeschlossene Lautsprecherkanäle können die Stereowirkung beeinträchtigen.
3. Die Lautsprecher mit korrekter Polarität anschließen ((+) an (+) und (-) an (-)). Umgekehrte Polarität würde die Stereowirkung beeinträchtigen.
4. Stecker und Kabel fest anschließen. Schlechter Kontakt kann sich in Brummen auswirken oder gar das Gerät beschädigen.
5. Die Gesamtstromaufnahme der angeschlossenen Geräte darf die Nennleistung der Netzsteckdosen auf der Geräterückwand nicht überschreiten.
6. Die ungeschalteten Netzsteckdosen (UNSWITCHED AC) werden nicht ausgeschaltet, wenn der Hauptnetzschalter auf der Gerätevordersseite ausgeschaltet wird.**
7. Falls Ihr Plattenspieler einen separaten Erdungsdraht hat, sollten Sie diesen an die GND-Anschlußklemme anschließen.
8. Verwenden Sie Lautsprecher mit korrekter Impedanz. Dieser Verstärker ist für den Einsatz mit Lautsprechern einer Impedanz von 4 bis 16 Ohm vorgesehen.
9. Anschluß des mitgelieferten Digitalsignalkabels.
Vor Anschluß des Faseroptikkabels an die DIGITAL 1 opto-Eingangsbuchse ist die Abdeckung der Buchse zu entfernen.
Da das Faseroptikkabel aus Glas oder Kunststoff ist, sollten Sie darauf achten, es nicht extrem zu biegen oder zu knicken. Schließen Sie das Digitalsignal-Ausgangskabel NUR an den Digitalausgang an.
10. Wenn ein Gerät an die Digital-Anschlußbuchsen des vorliegenden Verstärkers angeschlossen ist, erfolgt keine Betriebsregelung über COMPU LINK. (Damit soll versehentliche Betätigung verhütet werden.)
11. Wenn das Kassettendeck über COMPU LINK angeschlossen wird, sollte es an die entsprechenden DAT 1/TAPE 1-Anschlußbuchse des Verstärkers angeschlossen werden, um Oszillation zu verhindern. Darüber hinaus sollte TAPE DECK an die Klemmen von DAT 2/TAPE 2 angeschlossen sein. Dabei sind die entsprechenden COMPU LINK-Anschlüsse verschieden. Schließen Sie keine COMPU LINK-Kabel an die Anschlußbuchsen TAPE DECK oder DAT DECK an.
* Nicht vorzufinden an den U.S.A., Kanada, Europa und Australien ausgelieferten Geräten.
** Gehört nicht zum Lieferumfang bei in Europa und Australien ausgelieferten Geräten.

- Ⓛ Cordon d'alimentation
- Ⓛ Sélecteur de tension de ligne CA*
Quand cet appareil est utilisé dans une région où la tension secteur est différente de celle qui est préétablie, replacer le sélecteur de tension sur la position correcte. Transformer le fusible selon la capacité désignée.
- Ⓛ Bornes de synchronisation (COMPU LINK-1/SYNCHRO)
Raccorder aux appareils prévus avec une borne COMPU LINK-1/SYNCHRO pour permettre le fonctionnement du système de commande COMPU LINK.

Remarques:

1. Mettre l'appareil hors tension lors du raccordement d'un appareil quelconque.
2. Raccorder les éléments de source en faisant attention de bien raccorder les canaux gauche et droit. Des canaux inversés risquent de dégrader l'effet stéréo.
3. Lors du raccordement des haut-parleurs, respecter la polarité, (+) sur (+) et (-) sur (-). Une polarité inversée risque de dégrader l'effet stéréo.
4. Raccorder à fond les prises et câbles. Un mauvais contact risque de provoquer des ronflements.
5. Ne pas raccorder d'appareil nécessitant plus d'alimentation que celle qui est spécifiée aux prises CA du panneau arrière.
6. Les prises UNSWITCHED AC ne sont pas mises hors circuit quand l'interrupteur d'alimentation du panneau frontal est mis sur la position d'arrêt.**
7. Si votre platine tourne-disque a un câble de mise à la terre séparé, le raccorder à cette borne.
8. Utiliser des haut-parleurs d'impédance correcte. Cet ampli peut accepter des haut-parleurs ayant une impédance de 4 à 16 ohms.
9. Raccordement du câble de signal numérique fourni
Avant de raccorder le câble optique à la borne d'entrée optique numérique 1, enlever le couvercle de la borne.
Le câble optique est en matières plastiques ou en verre. Veiller donc à ne pas le plier violemment.
Connecter le câble de sortie numérique uniquement à la borne numérique.
10. Lorsque l'appareil est raccordé aux bornes numériques du présent amplificateur, ce dernier n'est pas mis en fonction par le système COMPU LINK. (Cela permet d'éviter le fonctionnement accidentel.)
11. Lorsqu'elle est raccordée par le système COMPU LINK, la platine d'enregistrement doit être raccordée aux bornes de magnétophone audionumérique 1/bande 1 (DAT 1/TAPE 1) correspondantes de l'amplificateur, et l'enregistreur audionumérique (DAT DECK) doit être raccordé aux bornes de magnétophone audionumérique 2/bande 2 (DAT 2/TAPE 2) correspondantes. Lorsque les bornes analogique et numérique de l'enregistreur audionumérique (DAT DECK) sont raccordées, la borne analogique doit être raccordée à la borne de magnétophone audionumérique 1/bande 1 (DAT 1/TAPE 1) de l'amplificateur afin d'empêcher l'oscillation. De plus, l'enregistreur audionumérique (DAT DECK) doit être raccordé aux bornes de magnétophone audionumérique 2/bande 2 (DAT 2/TAPE 2) de l'amplificateur. En tel cas, les raccordements du système COMPU LINK sont différents. Ne pas donc raccorder les câbles du système COMPU LINK à la platine d'enregistrement (TAPE DECK) ou à l'enregistreur audionumérique (DAT DECK).
* Non prévu sur les appareils destinés aux Etats-Unis, au Canada, à l'Europe Continentale, au Royaume-Uni et à l'Australie.
** Pas prévues sur les appareils pour l'Europe continentale, le Royaume-Uni et l'Australie.

HOW TO USE S.E.A. GRAPHIC EQUALIZER

The present unit does not have a tone control circuit since it was designed on the principle of basic amplifier.

To enjoy full SOUND FIELD control and TONE adjustment you can connect a SEA graphic equalizer to the DAT 2/TAPE 2 terminals of the amplifier.

Note:

- When the D/A CONVERTER DIRECT function is ON, the SEA graphic equalizer connection will not operate.

BEDIENUNG DES GRAPHISCHEN S.E.A.- EQUALIZERS

Das vorliegende Gerät hat keinen Tonregler, da es als Grundverstärker konzipiert ist. Um volle Klangfeldsteuerung und Tonregelung zu erhalten, sollten Sie einen SEA GRAPHIC EQUALIZER an die DAT 2/TAPE 2-Anschlußbuchsen des Verstärker anschließen.

Hinweis:

- Wenn D/A CONVERTER DIRECT eingeschaltet ist (ON), ist der Anschluß des SEA GRAPHIC EQUALIZERS nicht mehr aktiv.

FUNCTIONNEMENT DE L'EGALISEUR GRAPHIQUE S.E.A.

Le présent appareil n'est pas muni d'un circuit de contrôle de tonalité dans la mesure où il a été conçu en principe comme amplificateur de base. Pour apprécier le contrôle complet de champ sonore (SOUND FIELD) et le réglage de tonalité (TONE), il est possible de raccorder un égaliseur graphique SEA (SEA GRAPHIC EQUALIZER) aux bornes de magnétophone audionumérique 2/bande 2 (DAT 2/TAPE 2) de l'amplificateur.

Remarque:

- Lorsque la fonction D/A CONVERTER DIRECT est sur la position marche (ON), le raccordement de l'égaliseur graphique SEA ne fonctionne pas.

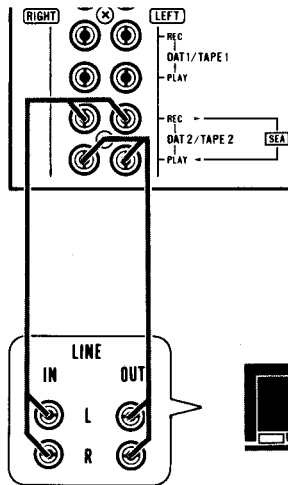

SEA graphic equalizer
Graphischen SEA equalizer
Egaliseur graphique SEA
SEA grafische equalizer
Ecuilizador grafico SEA
SEA grafisk equalizer

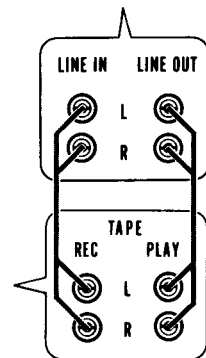

Cassette deck
Kassetendeck
Platine à cassette
Cassetdeck
Magnetofono
Kassetdäck

Fig. 17
Abb. 17
Afb. 17

OPERATION

To control the SOUND FIELD and adjust TONE

1. Press the DAT 2/TAPE 2 MONITOR button.
2. Operate the slide controls of the SEA graphic equalizer.

Recording with the SEA graphic equalizer

1. Press the SEA REC button on the SEA graphic equalizer.
2. Press the DAT 2/TAPE 2 MONITOR button.
3. Operate the slide controls of the SEA graphic equalizer.
4. Press the buttons of the tape deck to begin recording.

For more details of its connection and operation, refer to the instruction book of the S.E.A. graphic equalizer.

BEDIENUNG

Um Klangfeld und Ton zu steuern:

1. DAT 2/TAPE 2 MONITOR-Taste betätigen.
2. Die Schieberegler am SEA GRAPHIC EQUALIZER betätigen.

Aufnahmen mit dem SEA GRAPHIC EQUALIZER

1. Die SEA REC-Taste am SEA GRAPHIC EQUALIZER betätigen.
2. DAT 2/TAPE 2 MONITOR-Taste betätigen.
3. Die Schieberegler am SEA GRAPHIC EQUALIZER betätigen.
4. Die Aufnahme mittels der Tasten des Kassettendecks beginnen.

Weitere Angaben zu Anschluß und Betrieb des S.E.A. Graphic Equalizer sind in dessen Bedienungsanleitung zu finden.

FUNCTIONNEMENT

Pour contrôler le champ sonore (SOUND FIELD) et pour régler la tonalité

1. Appuyer sur la touche de moniteur de magnétophone audionumérique 2/bande 2 (DAT 2/TAPE 2 MONITOR).
2. Pour manipuler les commandes progressives de l'égaliseur graphique SEA.

Pour l'enregistrement avec l'égaliseur graphique SEA

1. Appuyer sur la touche d'enregistrement SEA (SEA REC) de l'égaliseur graphique SEA.
2. Appuyer sur la touche de moniteur de magnétophone audionumérique 2/bande 2 (DAT 2/TAPE 2 MONITOR).
3. Pour manipuler les commandes progressives de l'égaliseur graphique SEA.
4. Appuyer sur les touches de la platine d'enregistrement (TAPE DECK) pour commencer l'enregistrement.

Pour plus de détails sur les raccordements et le fonctionnement de l'égaliseur graphique, voir son manuel d'instructions.

Description of Technology

■ Digital Pure-A

"Digital Pure-A" is an entirely new amplifying system that makes possible high-efficiency class-A operation in the output stage by optimally controlling the power amplifier, so that there is no signal deterioration, based on the concept of "signal prediction".

The basic concept of "Digital Pure-A" and the principles of its operation are described in the following.

(1) Priority of "pure" class-A operation

Class-A amplification is the target of all amplification operations. However, since this requires too much power in the output stage, it is inefficient. Thus, class-B operation or modified class-B ("pseudo" class-A) operation (such as JVC's "Dynamic Super-A") are generally used in amplifiers for higher power with high efficiency.

In class-B operations, different transistors are used to amplify the upper and lower halves of the input waveform, then these two amplified waveform halves are combined in the final stage (called the "push-pull" amplifier). In this type of amplification, the current waveforms include large harmonic distortion components. In most amplifiers, these distortion components cancel each other, and thus distortion in the output waveform is greatly reduced. However, residual distortion components remain, and these cause switching distortion around the zero-cross point.

On the other hand, in class-A operations, since each of the upper and lower output transistors amplifies input waveforms which are symmetrical to the output waveform, theoretically, harmonic distortion will never occur. Also, since the operation current does not cause distortion, the impedance of the power supply does not affect the output current. And, since the upper and lower transistors are always active, their ability to drive lower impedance loads is greatly improved, as well as their having higher resistance to distortion, etc. This improvement in efficiency, which is the only weak point of class-A amplifiers, has long been a point of discussion among amplifier engineers.

(2) Amplifier output in actual use

From the results of our research into amplifiers as they are used, we confirmed that an amplifier's output in normal listening conditions is only a few (2 or 3) watts, and the average output level is 10 or more dB lower than the actual maximum output of the amplifier when the level is adjusted with the peak output level set to the amplifier's maximum output power. Also, for the reproduction of music, the maximum output power is hardly ever required for long periods; most of the time it is only required to deliver moderate power.

That is, the ideal amplifier design could be realized by a low-power output class-A amplifier with the ability to operate at a moderate output power, but which could operate as a high-power class-A amplifier only when a higher output is required. Our result is the "Digital Pure-A" circuitry - one possible approach to the ideal amplifier design.

■ Operation Principles

In the past, there were amplifiers which could select the output power or operating point. However, since they performed their processing in real time, using the output signal, parts of the signal waveform could be missing, because of the control circuit time delay, and this caused increased distortion. This made it very difficult to improve the sound quality. As a solution to this problem, in our new Digital Pure-A concept, a Time Base Processor (delay device) is placed just before the D/A converter, and the timing with which the signal is output from this is used as the reference on the time axis.

This TBP (Time Base Processor) is used to shift the time axis with no signal deterioration, using the unique nature of digital signals. With this circuit, the input signal is stored for a fixed period and is then output with a slight time delay; that is, the signal directly input to the power amplifier stage precedes the signal that passes through the Time Base Processor where it is delayed for a certain, fixed period.

In the next step, a circuit measures the current voltage gain corresponding to the delayed output signal and the level of the signal currently being output by the power amplifier. By calculating the voltage gain measured in this way using the preceding signal as described, the output signal level required for the subsequent signal which will arrive a fixed period later can be "predicted". Based on this "prediction signal", the power voltage supplied to the power amplifier and the operating point of the output stage are controlled, so that highly-efficient class-A operation of the output stage is made possible. (Refer to Figs. 1 and 2.)

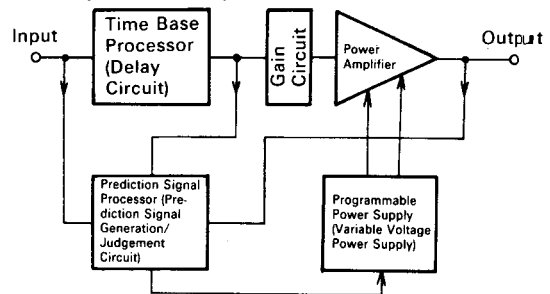
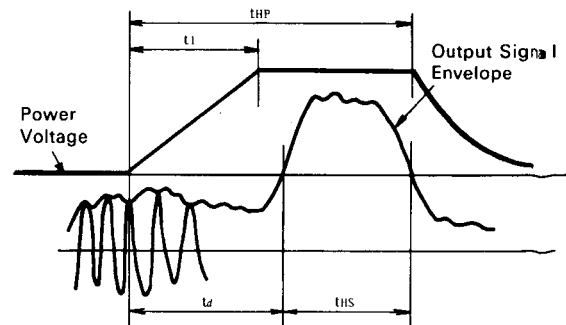

Fig. 1 Basic Block Diagram



Conditions such that there is no lack of waveforms:
 $t_1 < t_{-} \quad t_{MP} > t_{-} + t_{HS}$
 ... t_{-} : Delay time of Time Base Processor
 t_1 : Time required to switch over the voltage
 t_{HS} : Period requiring high voltage
 t_{MP} : Period to control the voltage

Fig. 2 Operation Concept

■ Components making up the "Digital Pure-A" circuit

The three major circuit components used in "Digital Pure-A", are described in the following:

(1) Time Base Processor

In conventional amplifiers, the input digital signal is decoded in the built-in digital decoder and applied to the D/A converter. However, in "Digital Pure-A", the input digital signal is stored in memory and output to the subsequent stage only after a fixed period has elapsed; in this way, the signal is delayed with no distortion.

In this circuit, a 256K-Byte DRAM is controlled by a newly-developed LSI with 1200 gates, to obtain a delay time of 150 msec. Also, an 8-bit parallel output is provided for an 8-bit D/A converter. (Fig. 3)

(2) Prediction Signal Processor (Prediction Signal Generation/Judgement Circuit)

To accurately measure and operate at the maximum voltage gain of the amplifier, without it being affected by the phase difference or gain difference between the channels, the waveforms are processed by full-wave peak-hold circuits, in which the minimum value of the delayed output is detected as well as the maximum value of the power amplifier output. If the operating result becomes unstable, such as when a non-signal section is reproduced, the judgement system is changed to another system having different parameters.

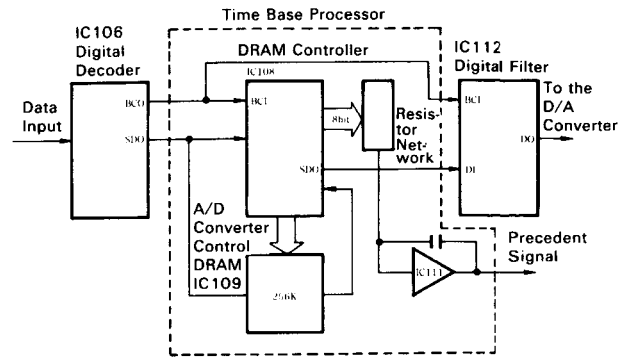

Fig. 3 Time Base Processor

The preceding signal is passed through the absolute value circuit, in which it is multiplied by the voltage gain coefficient, to generate the prediction signal. This "prediction" signal is compared with the reference value, so that the output signal can be used to control the power voltage and as the operation point control signal.

Furthermore, this signal is compensated for by a temperature sensor in the amplifier, to extend the period for which class-A operation continues to maximize the output, as well as to improve the reliability of the amplifier. (Refer to Fig. 4.)

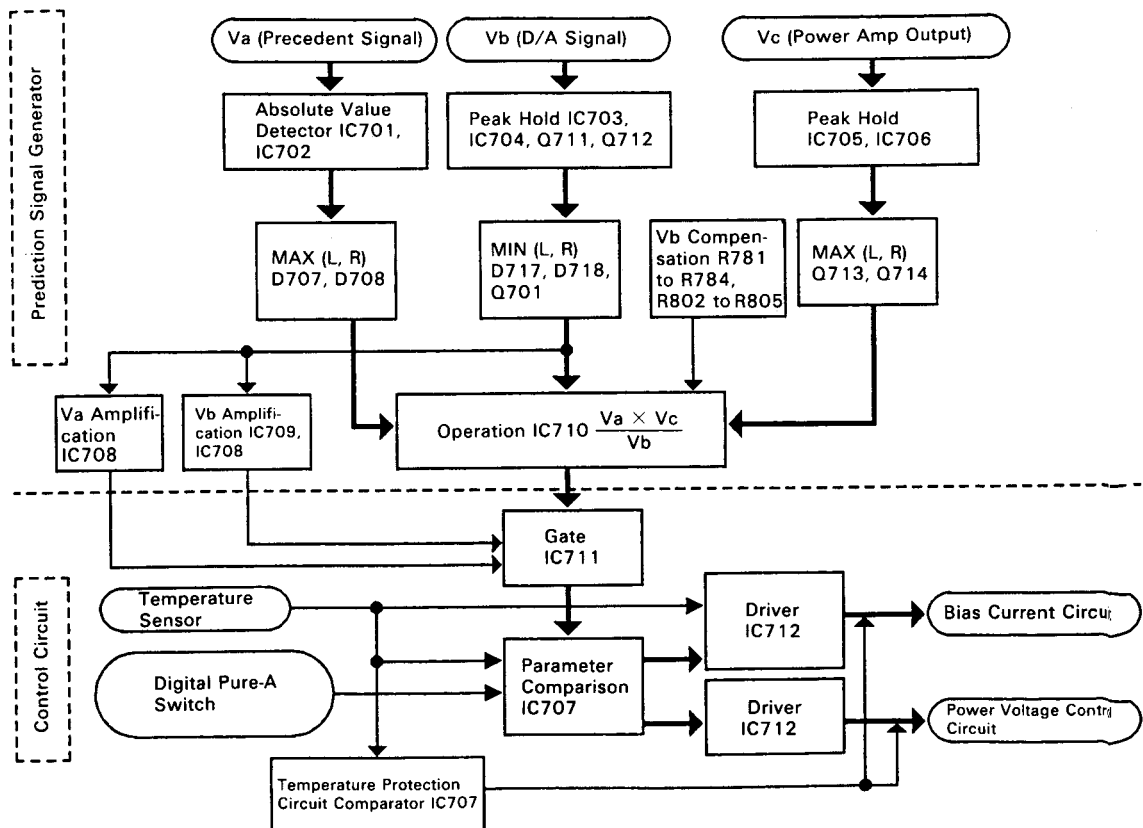

Fig. 4

**(3) Programmable Power Supply
(Variable Voltage Power Supply)**

To improve the power efficiency of the output stage, the power voltage should be varied according to the input signal. But, if switching were to be done using a thyristor, etc., the charging current of the power supply would fluctuate due to commutation current, and this could cause noise. For the "Digital Pure-A" circuit, a constant current switching circuit has been developed using newly developed low-saturation bipolar transistors, so that the voltage drift is kept at a fixed level. As a result, the switching operation of the power supply can be completed in about 120 msec. With this, switching noise is greatly reduced and effects picked up from the AC line are minimized. (Refer to Figs. 5 and 6.)

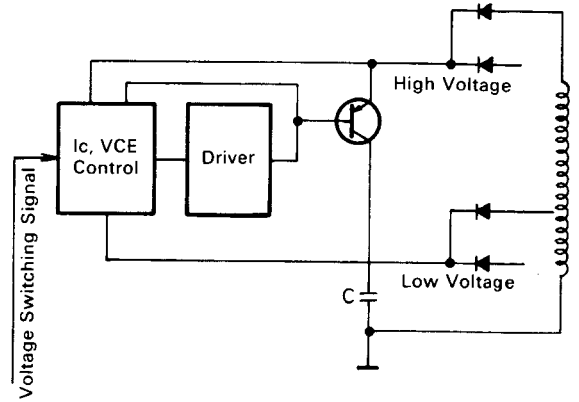

Fig. 5 Voltage Switching Circuit

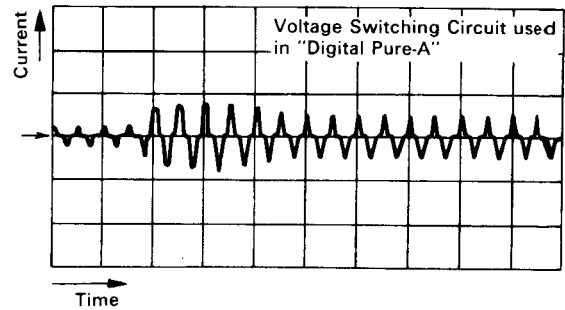
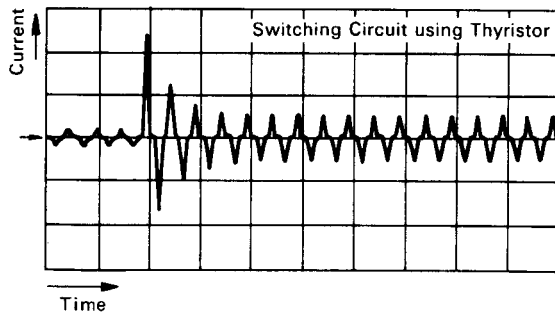
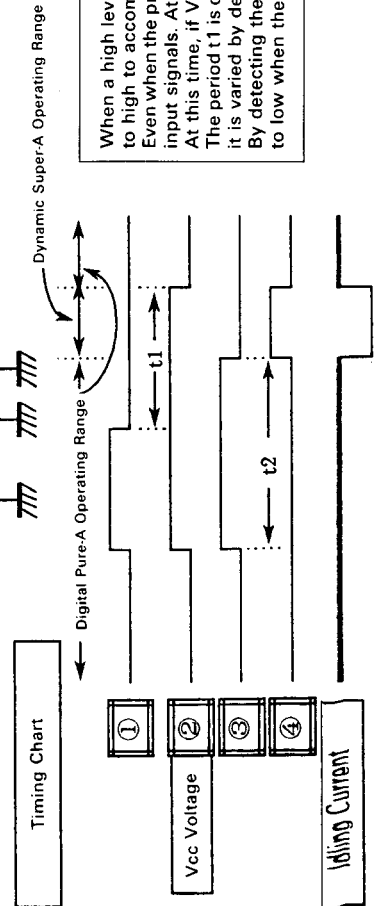
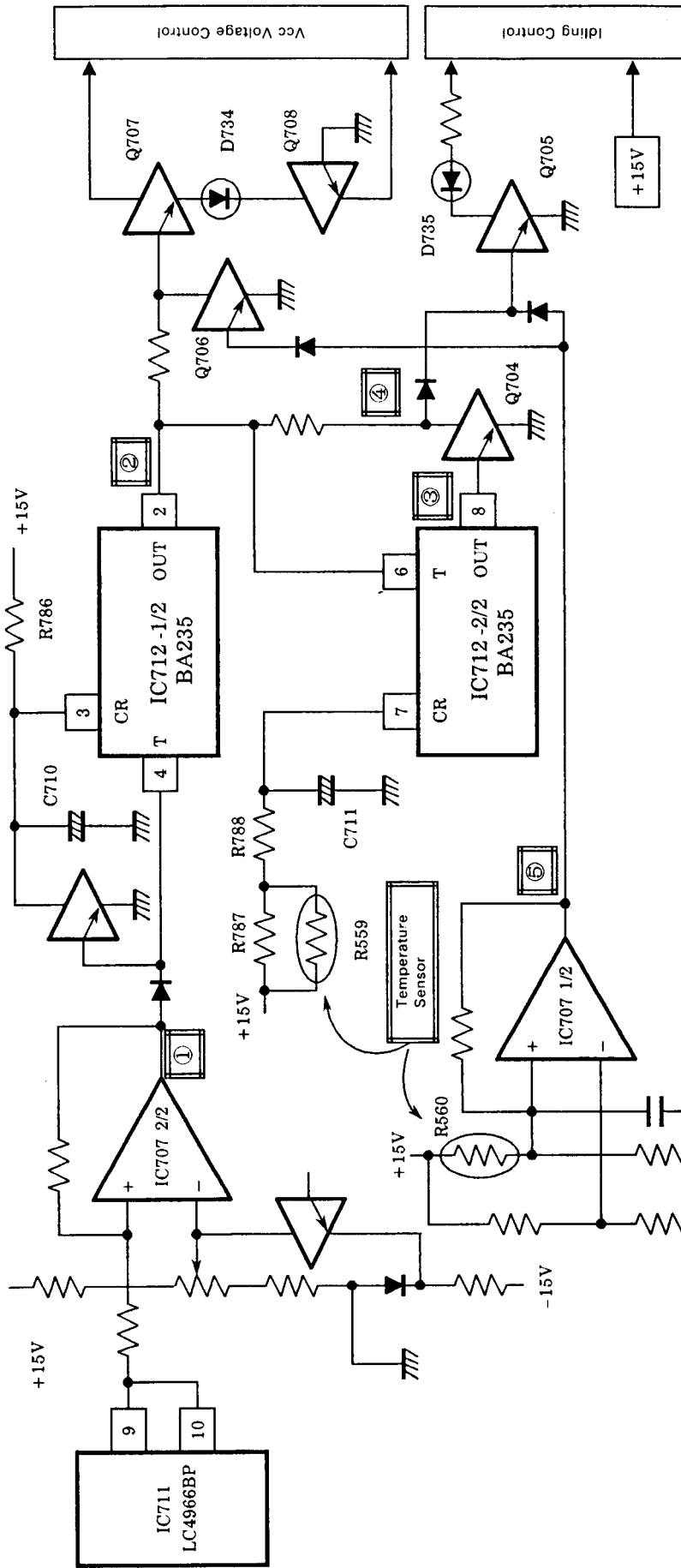

Fig. 6 Comparison between Voltage Switching Circuits

■ Digital Pure-A Control Block Diagram



When a high level signal is detected in the prediction signal, ① goes high and ② also goes high, then Vcc is changed to high to accommodate the higher power output. Even when the prediction signal lowers, Vcc maintains the high level status for a fixed time to prepare for the subsequent input signals. At the same time, the timer (IC712-2/2) goes high, then goes low after a fixed period (ts) has elapsed. At this time, if Vcc is still at the high level, Q704 pin (4) goes high to reduce the idling current. The period t1 is determined by R780 and C710. The period t2 is determined by R787, R788, R599 and C711. However, it is varied by detecting the ambient temperature with R559. By detecting the ambient temperature and inverting (5) to high, both Vcc and the idling current are forcibly inverted to low when the temperature exceeds the fixed degree.

Muting Circuit Diagram

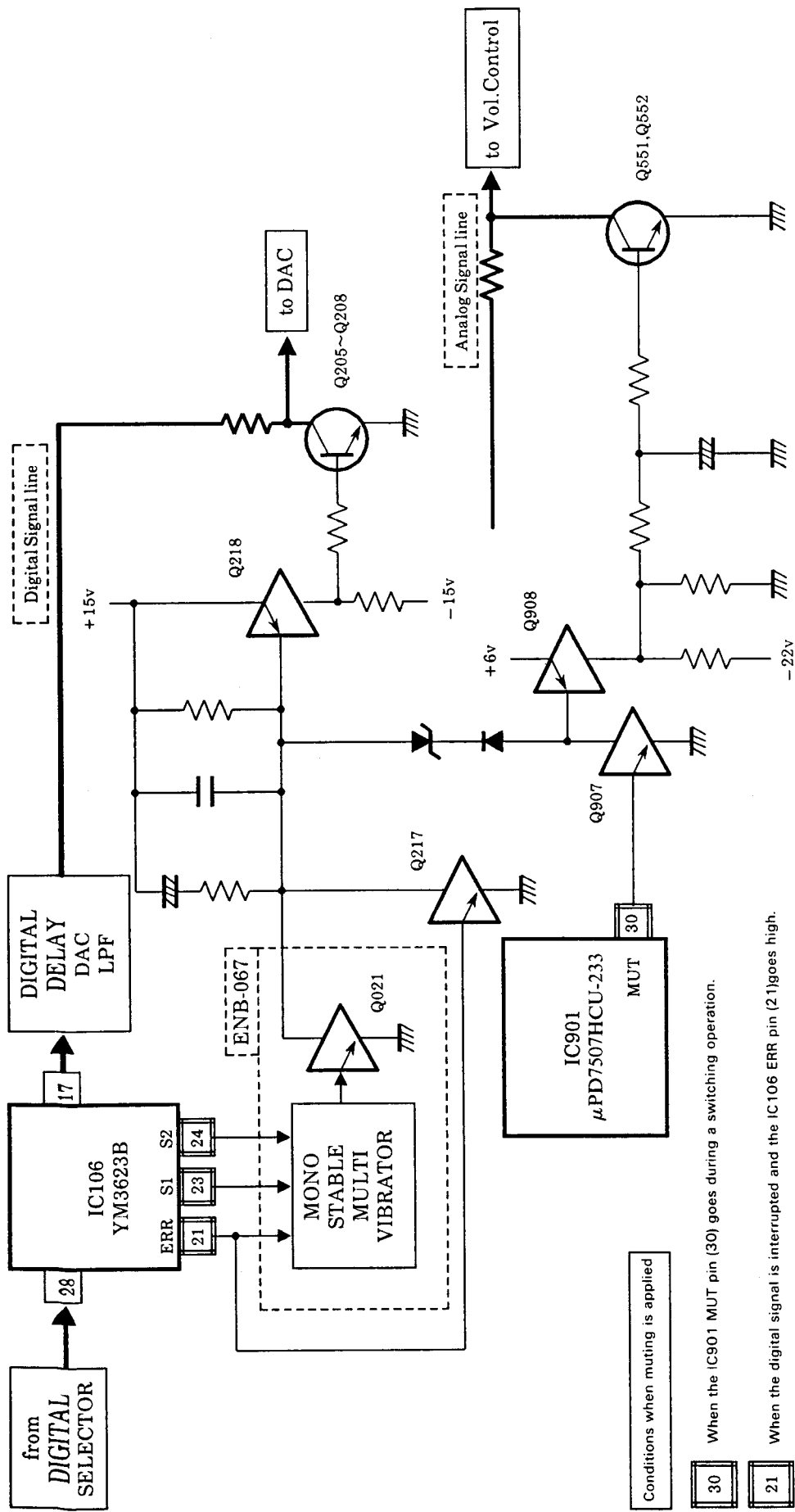

- 30 When the IC901 MUT pin (30) goes during a switching operation.
- 21 When the digital signal is interrupted and the IC106 ERR pin (21) goes high.
- 23 When the sampling frequency is changed and IC106 S1 (23) and S2 (24) are varied.

Status of S1 and S2 in IC106 depends on the sampling frequency	S1	H	L	L	L	48kHz
	S2	H	H	L	L	44kHz

Description of Major ICs

■ TORX172 (J101) : Optical Receiving Module

(1) Circuit Construction

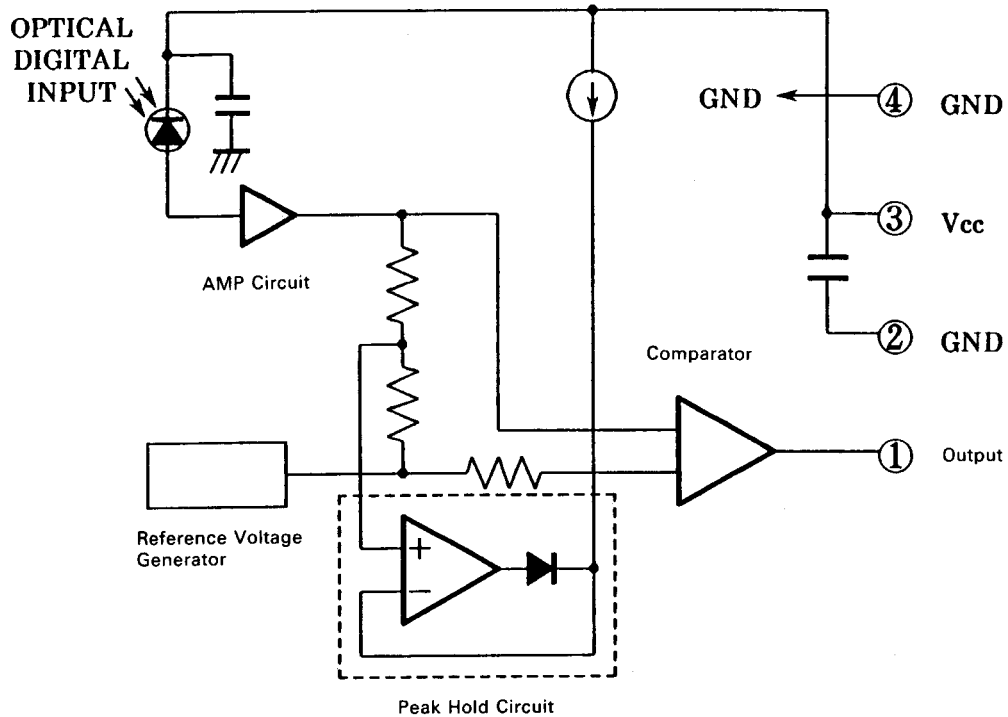

(2) Circuit Description

When an optical signal is input to the Si-PIN photodiode, current flows with a sensitivity of 0.3 A/W ($\lambda_p = 650$ [nm]) or less. This current is impedance-converted and amplified by the AMP circuit, and the resulting signal voltage is input to the comparator.

At the same time, a reference voltage of the comparator is given by the ATC (Automatic Threshold Control) circuit. The ATC circuit consists of a peak hold circuit, which detects the peak value of the input voltage and maintains it for a certain period. The period in which the peak value is maintained is called the "time constant". It is set for 1 - 3 μ s for "Toslink" (used in this unit).

The signal voltage from the AMP circuit is divided in two by a resistor and input to the peak hold circuit. Therefore, the comparator compares the output voltage of the AMP circuit with the peak value of 1/2 of the output voltage. For this, the comparator output can accurately reproduce the signal transmitted from the optical transmission module of the transmitter at any time, even if the optical input fluctuates.

Furthermore, since a reference voltage generator is provided to keep the output voltage at the same level as the voltage output from the AMP circuit when there is no optical input, so that the reference voltage varies according to the temperature drift in the AMP circuit, a change in the characteristics due to a temperature change is minimized.

Also, a constant current power supply is provided and the reference voltage of the comparator is set slightly higher than the output voltage of the reference voltage generator so that the transmission is made accurately even under the condition when there is no optical input for a long period.

■ YM3623B (IC106): Digital Audio Interface Receiver

(1) Function

- 1) A PLL circuit is incorporated to synchronize with a digital signal (conforming to the Digital Audio Interface Format) which is transmitted from the outside. Therefore, the sampling frequency is followed up automatically.
- 2) This outputs the audio signal with its MSB (most significant bit) first. In synchronism with it, this outputs the timing clock for sampling and holding the D/A output, L-channel and R-channel signals.
- 3) Since it provides the pins used for outputting the subcode signals, only the subcode data can be picked up.
- 4) It can output the sampling frequency, as well as signals indicating the presence/absence of copy enable, emphasis and error in the audio signal transmitted.
- 5) When an error is detected in a digital signal conforming to the Digital Audio Interface Format, the previous audio data is output again.

(2) Appearance

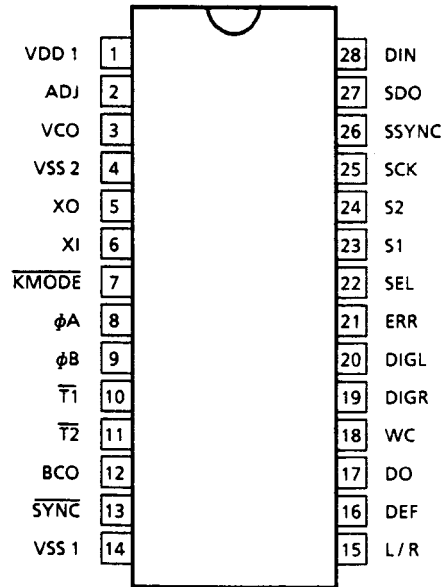

(3) Block Diagram

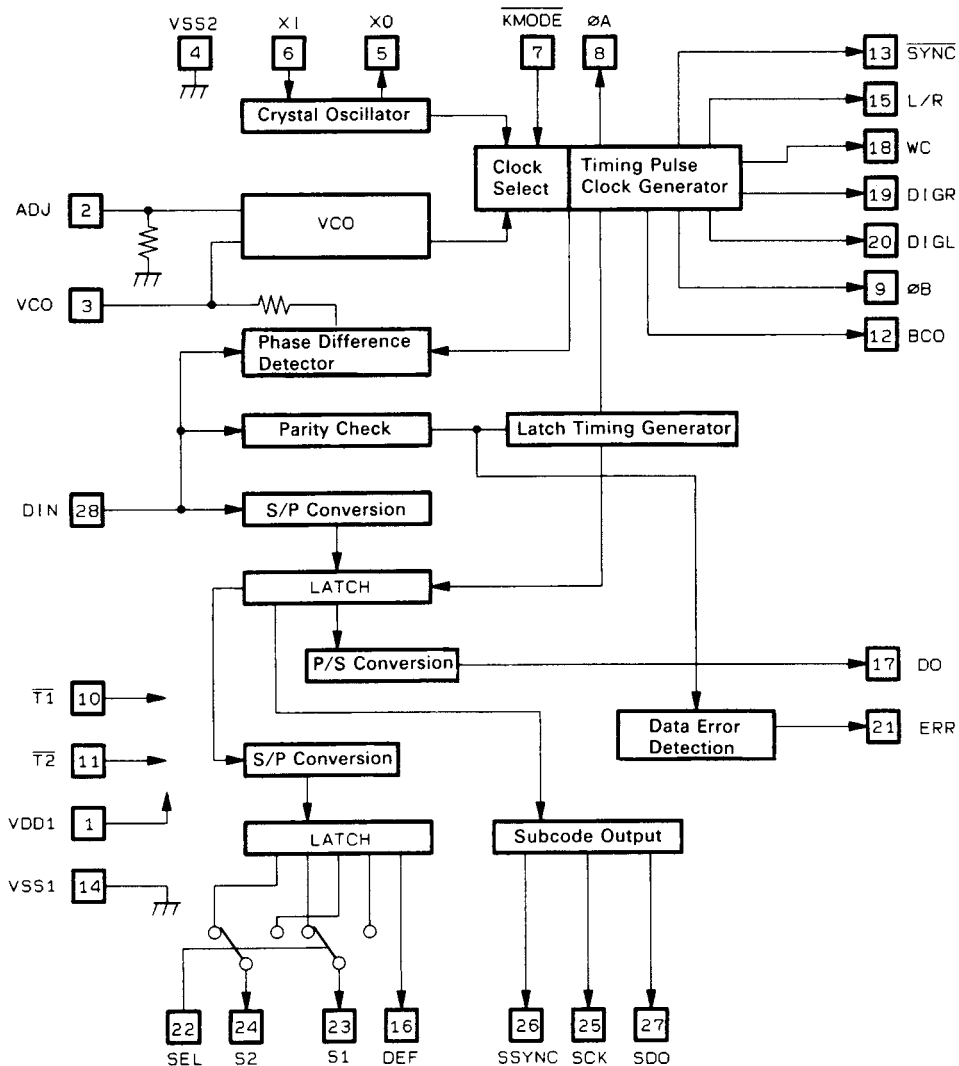

(4) Pin Descriptions

Pins accompanied with (PU) are pulled up internally.

Pin No.	Pin Name	I/O	Functions
1	VDD		System power supply (+5 V)
2	ADJ	I	VCO oscillator frequency adjustment pin. No connection.
3	VCO	I/O	Externally connected capacitor pin for the VCO circuit
4	VSS2		GND pin for the VCO circuit. Connected in common with VSS1. They are not common inside of the LSI.
5	XO	O	Ceramic oscillator pin (18.00 MHz)
6	XI	I	Ceramic oscillator pin
7	KMODE	I (PU)	H: Activates the PLL circuit when a signal is input to the DIN pin. Operates using the ceramic oscillator when there is no input to the DIN pin. L: Ceramic oscillator is used regardless of the state of the DIN pin.
8	ϕA	O	18.00 MHz when the ceramic oscillator is used. When the PLL circuit is engaged, the frequency varies according to the data rate of the signal input to the DIN pin. (About 16.9344 MHz when $f_s = 44.1$ kHz)
9	ϕB	O	1/3-divided ϕA when the ceramic oscillator is used. When the PLL circuit is engaged, the frequency varies according to the data rate of the signal input to the DIN pin. (About 5.6448 MHz when $f_s = 44.1$ kHz)
10	$\overline{T1}$	I (PU)	Internal circuit check pin
11	$\overline{T2}$	I (PU)	Internal circuit check pin
12	BCO	O	Timing clock of the signal output from the DO pin
13	\overline{SYNC}	O	Sync signal
14	VSS1	O	System GND
15	L/R	O	H: Indicates L-channel data is output from the DO pin. L: Indicates R-channel data is output from the DO pin.
16	DEF	O	H: Indicates that the input data has been emphasized. L: Indicates that the input data has no emphasis code.
17	DO	O	16-bit data output
18	WC	O	Indicates that the data is output to the DO pin.
19	DIGR	O	R-channel deglitch signal
20	DIGL	O	L-channel deglitch signal
21	ERR	O	H: Indicates a parity error, or operation with the ceramic oscillator. L: Indicates no error.
22	SEL	I (PU)	Refer to the table below.
23	S1	O	Refer to the table below.
24	S2	O	Refer to the table below.
25	SCK	O	Clock for the subcode output
26	SSYNC	O	Subcode signal
27	SDO	O	Subcode data output pin
28	DIN	I (PU)	Data input pin

* Concerning S1, S2 and SEL:

The S1 and S2 pins have a multiplied output function.

The S1/S2 output is changed by switching the SEL pin input.

Input	Output		Output	
	S1	Function	S2	Function
L	L	Copy inhibit	L	CD (other than DAT)
	H	Copy enable	H	DAT
H	L		L	DIN input signal's sampling frequency is 44.1 kHz
	L		H	48KHz
	H		H	32KHz
	H		L	—

As shown above, the required data are picked up from the input digital signal conforming to the Digital Audio Interface Format, and output to pins S1 and S2.

■ VC4082-2 (IC108)

(1) Outline

The VC4082-2 is the delay circuit gate array for the digital interface receiver (YM3622B: IC106). It is a delay device which writes the serial data transmitted from IC106 into the DRAM (IC109) and outputs the serial data after a fixed period (150 msec) has elapsed.

(2) Function

- 1) Parallel outputs the upper 8 bits of the serial data which is transmitted from IC106. (For the precedent signal)
- 2) Serially outputs the delayed serial data in synchronism with the BCO signal and the WC signal, which are transmitted from IC106.
- 3) Serially outputs the 2's complement data since operation starts until the first delay time has elapsed.
- 4) With the external RESET signal or the ERR signal transmitted from IC106, all of the internal memory is erased and the initialized status resumes in VC4082-2.
- 5) Outputs the 2's complement serial data, between the delayed L-channel and R-channel serial data.
- 6) Writes the serial data transmitted from IC106 into IC109 and at the same time, reads the serial data that the delay time has elapsed, by accessing by the read modified write cycle.
- 7) Enters START mode by detecting the rising edge of the external RESET signal (negative logic) or the falling edge of the ERR signal (positive logic) transmitted from C106, and enters operation mode by detecting the rising edge of the L/R signal transmitted from IC106.

(3) Internal Structure and Peripheral Connections

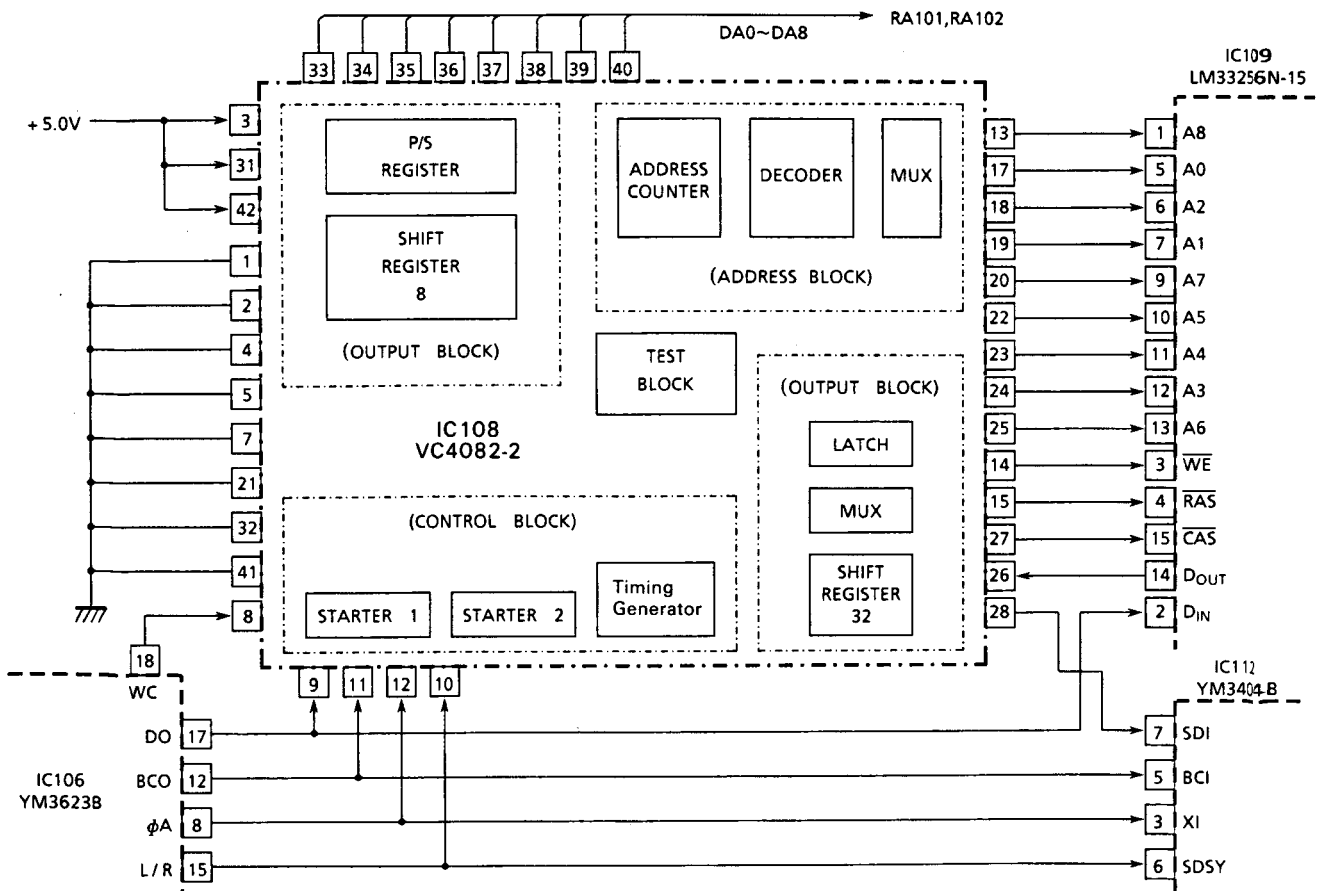

■ LM33256N-15 (IC109)

(1) Pin Assignment

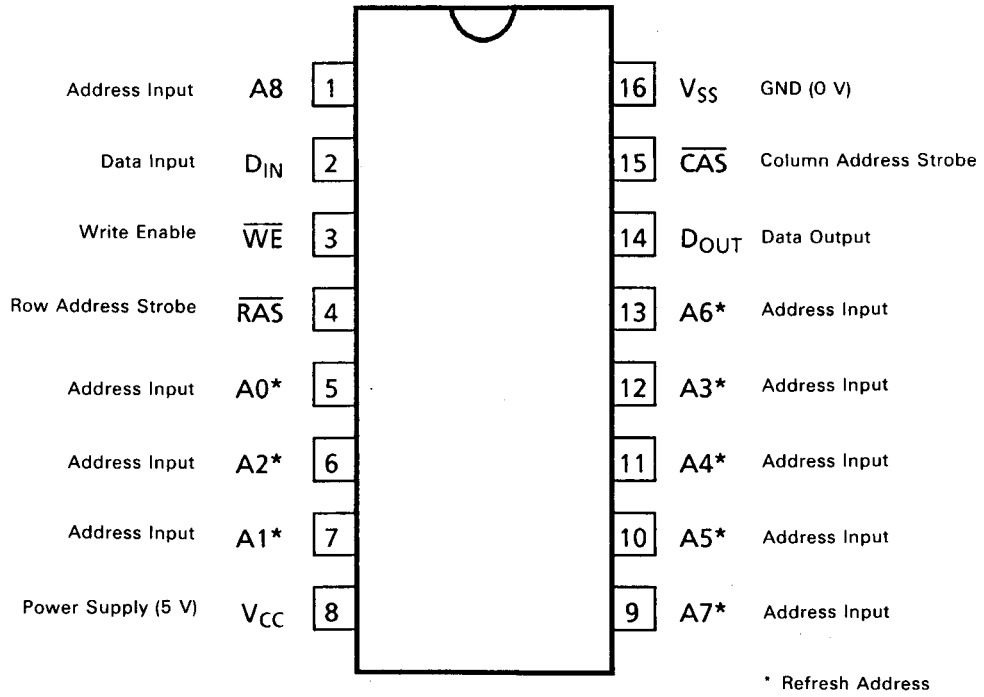

(2) Block Diagram

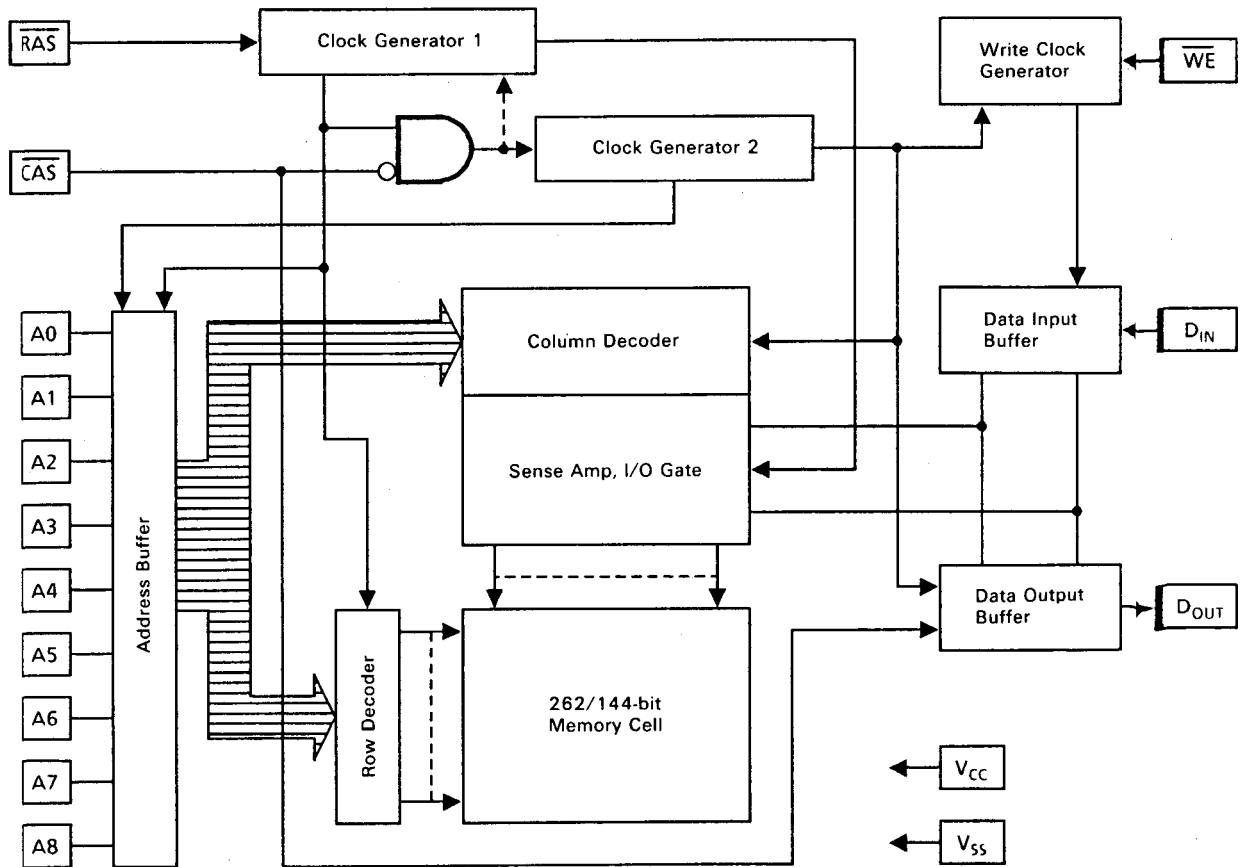

■ YM3404B (IC112): Quadruple Oversampling Digital Filter

(1) Appearance

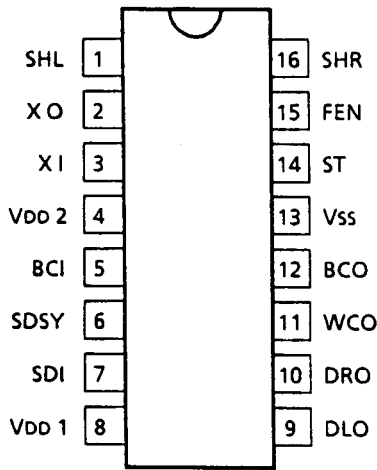

(2) Block Diagram

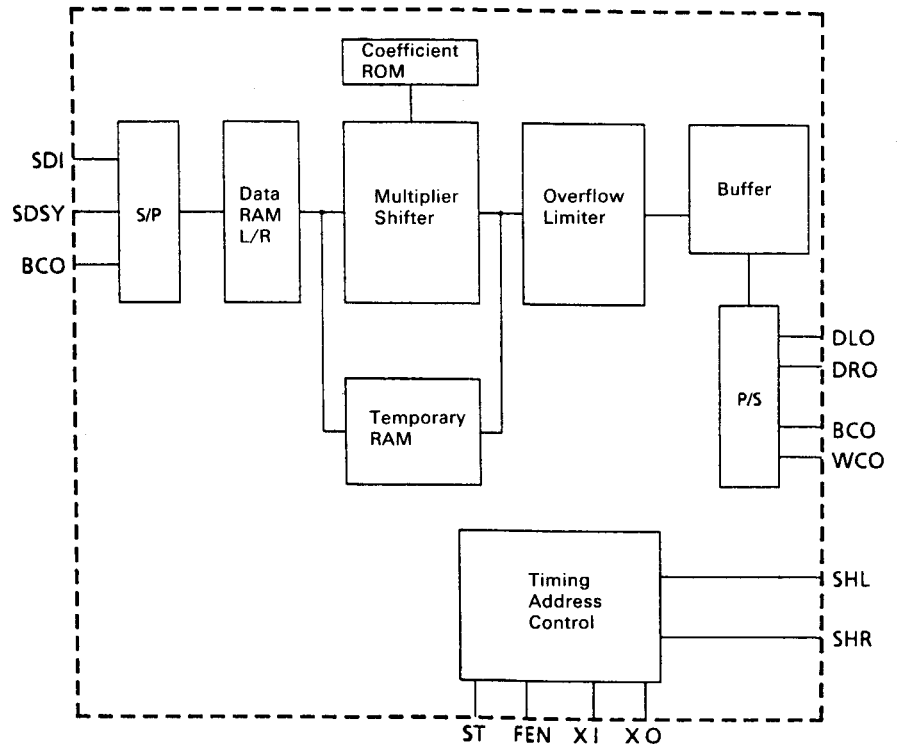

(3) Pin Description

Pin No.	Pin Name	I/O	Functions	Pin No.	Pin Name	I/O	Functions
1	SHL	O	When operating with 1 D/A converter: L-channel deglitcher signal When operating with 2 D/A converters: L/R channel deglitcher signal	9	DLO	O	When operating with 1 D/A converter (ST = low): L/R-channel data output When operating with 2 D/A converters (ST = high): L-channel data output
2	XO	O	Crystal oscillates with XO (Invert output of XI)	10	DRO	O	R-channel data output
3	XI	I	Crystal oscillates with XO. External clock can also be input directly. (196fs = 17.2872 MHz or 192fs = 16.9344 MHz)	11	WCO	O	Word clock for the output data DLO and DRO
4	Vdd 2		+5 V power supply pin for crystal oscillator and deglitcher signal	12	BCO	O	Output data bit clock, and system clock output pin for SPC2 and SPC3. (98fs = 8.6436 MHz or 96fs = 8.4672 MHz)
5	BCI	I	Inputs the input data bit clock	13	Vss		GND pin
6	SDSY	I	This pin differentiates the input data between the L and R channels, and defines the data input timing.	14	ST	I	1 DAC/2 DAC select pin 1 DAC (D/A converter) = low, 2 DAC (D/A converters) = high
7	SDI	I	Data input pin (Connected to SDO such as SPC1)	15	FEN	I	System clock select pin (196fs = low, 192fs = high)
8	Vdd 1		+5 V power supply, for the digital signal circuit	16	SHR	O	R-channel deglitcher signal when operating with 1 D/A converter.

Internal Block Diagrams of ICs

■ TC74HC86P (IC201)

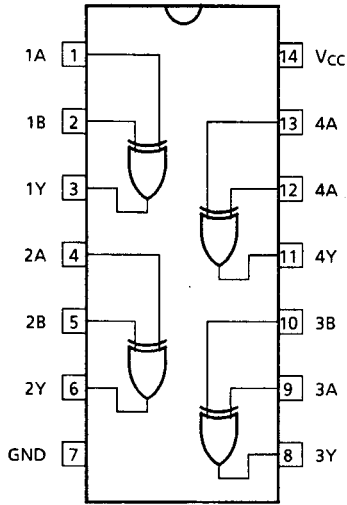

■ TC74HC27P (IC022)

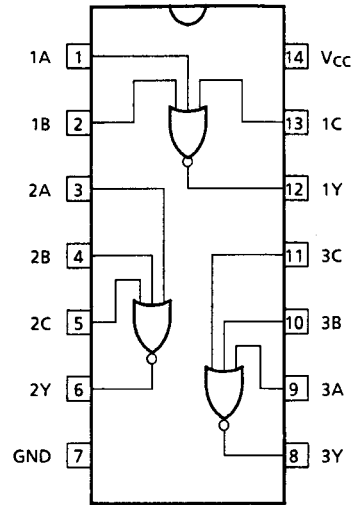

■ TC74HC123 (IC023)

(1) Pin Connections

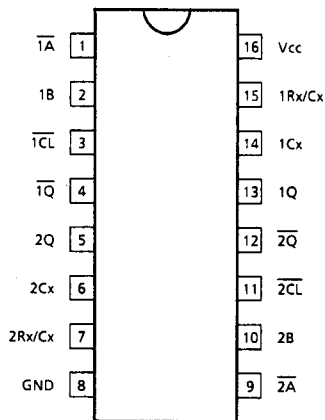

(2) Truth Table

INPUTS			OUTPUTS		NOTE
\bar{A}	B	$\bar{C}L$	Q	\bar{Q}	
	H	H			OUTPUT EN ABLE
H,L	L	H	L	H	INHIBIT
H	H,L	H	L	H	INHIBIT
L		H			OUTPUT EN ABLE
L	H				OUTPUT EN ABLE
H,L	H,L	L	L	H	INHIBIT

■ TC74HC04O (IC001)

■ TC74HCU04P (IC101)

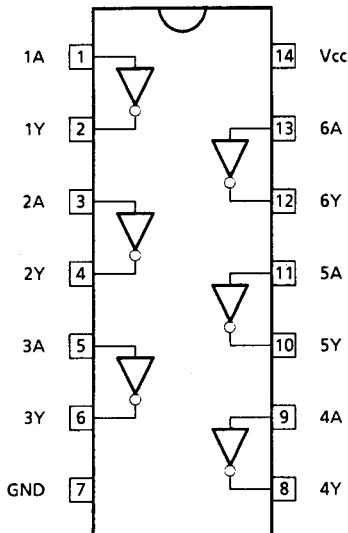

■ TC74HC125P (IC102, IC103)

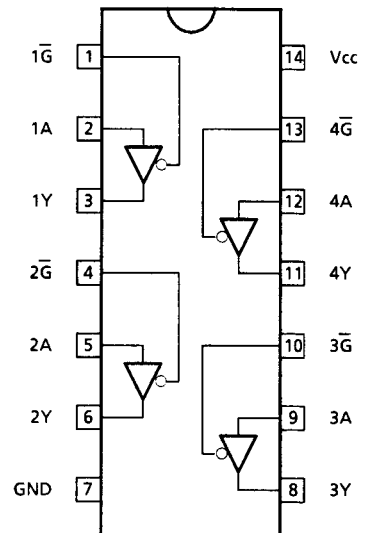

- NJM78M05A (IC105)
- NJM78M06A (IC902)

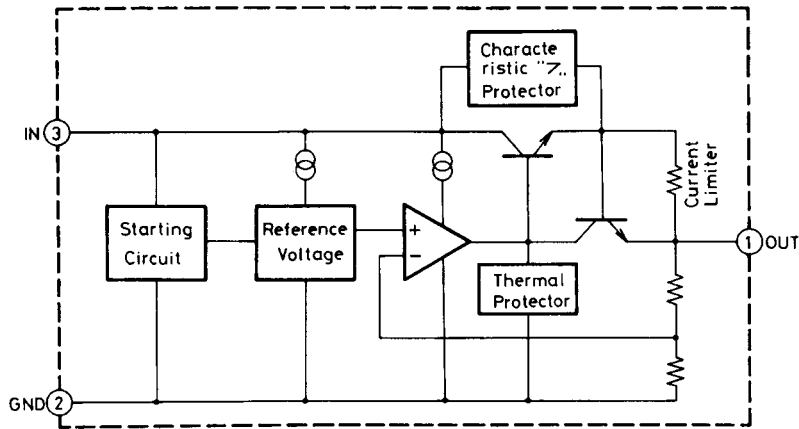

■ TC74HC238P (IC107)

(1) Logic Diagram

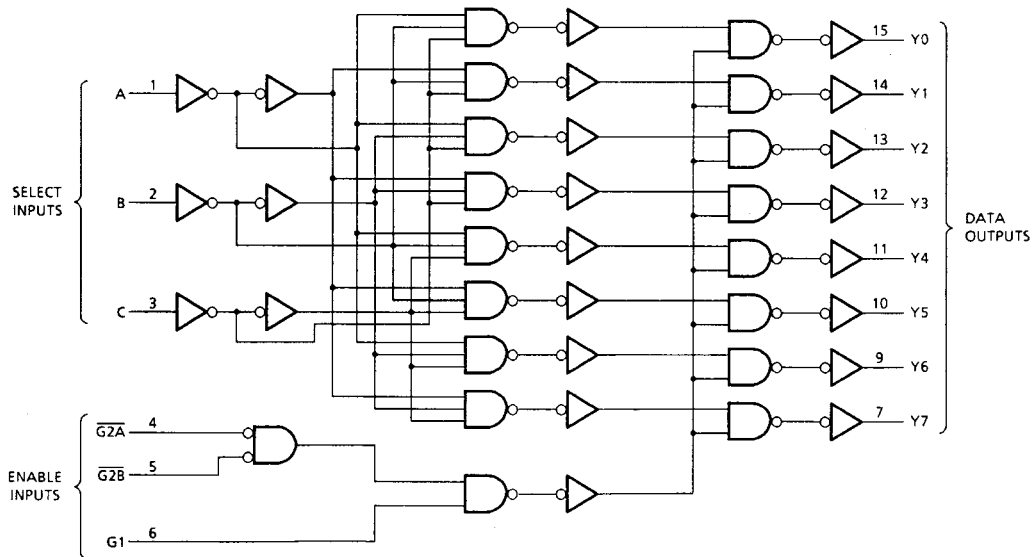

(2) Truth Table

I N P U T S						O U T P U T S								S E L E C T E D O U T P U T
E N A B L E			S E L E C T			Y0	Y1	Y2	Y3	Y4	Y5	Y6	Y7	
G2B	G2A	G1	C	B	A									
L,H	L,H	L	L,H	L,H	L,H	L	L	L	L	L	L	L	L	NONE
L,H	H	L,H	L,H	L,H	L,H	L	L	L	L	L	L	L	L	NONE
H	L,H	L,H	L,H	L,H	L,H	L	L	L	L	L	L	L	L	NONE
L	L	H	L	L	L	H	L	L	L	L	L	L	L	Y0
L	L	H	L	L	H	L	H	L	L	L	L	L	L	Y1
L	L	H	L	H	L	L	L	H	L	L	L	L	L	Y2
L	L	H	L	H	H	L	L	L	H	L	L	L	L	Y3
L	L	H	H	L	L	L	L	L	L	H	L	L	L	Y4
L	L	H	H	L	H	L	L	L	L	L	H	L	L	Y5
L	L	H	H	H	L	L	L	L	L	L	L	H	L	Y6
L	L	H	H	H	H	L	L	L	L	L	L	L	H	Y7

- TC4053BP (IC110)
- HD14053BP (IC202)

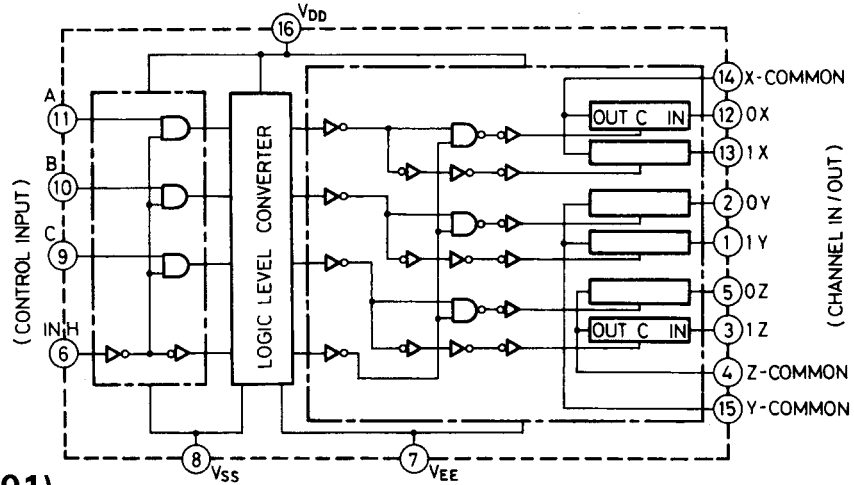

- PCM56 (IC201)

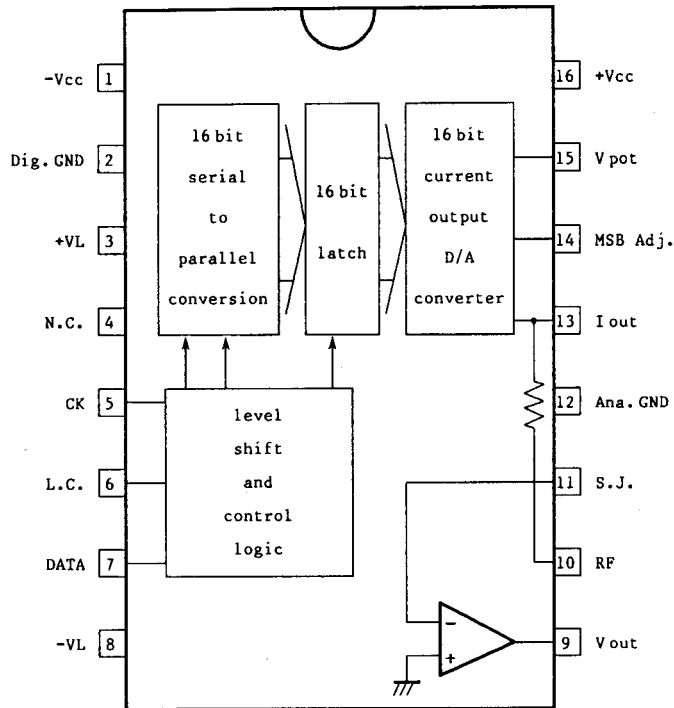

- BA15218N (IC701 ~ IC709)
- M5218L (IC205)
- NJM4560D-X (IC301)
- NJM5532D (IC203, IC204)

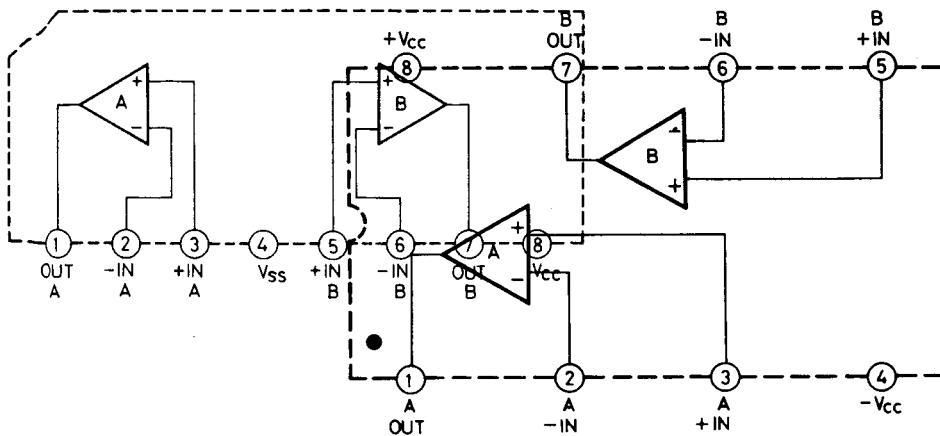

■ VC5022-2 (IC401, IC402)

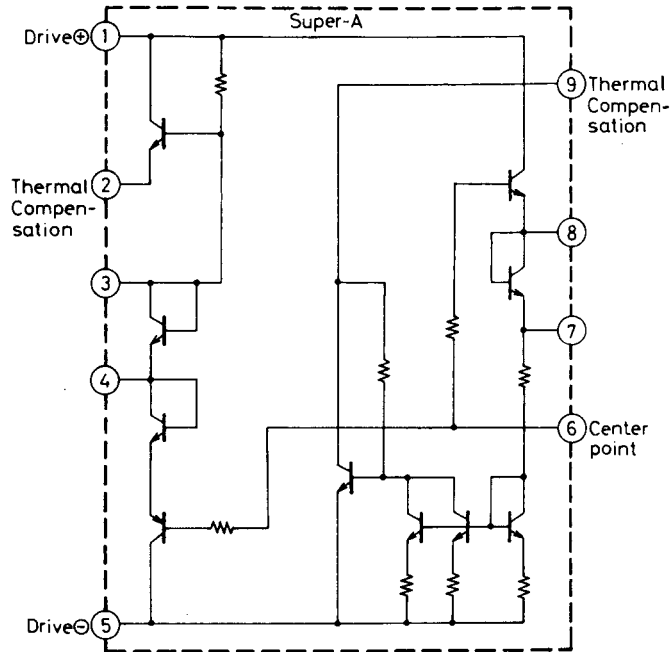

■ TA7317P (IC405)

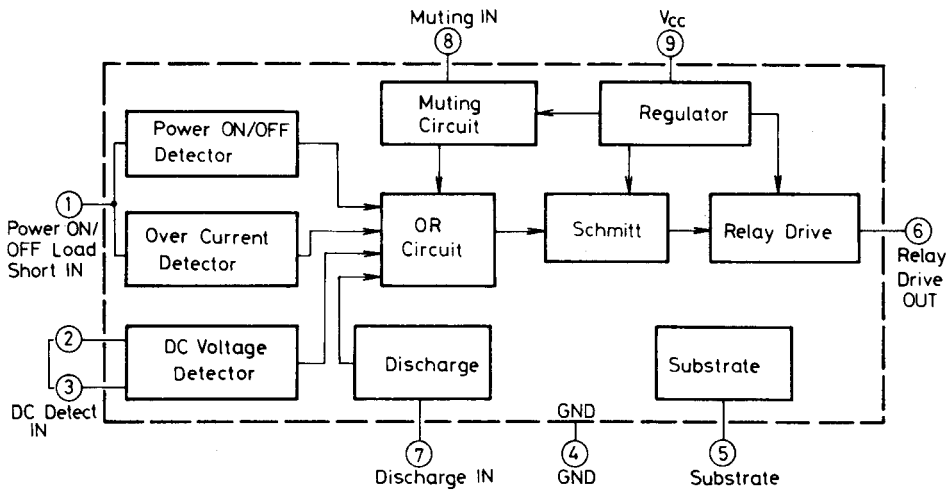

■ LB1639 (IC551)

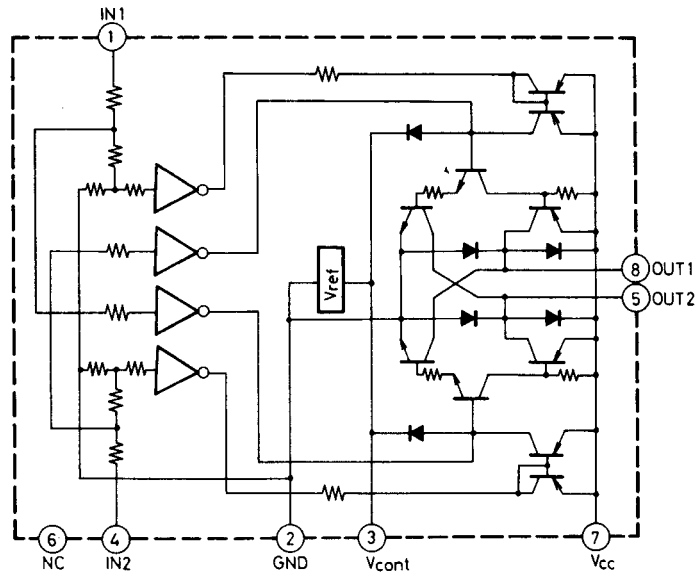

■ NJM4200D (IC710)

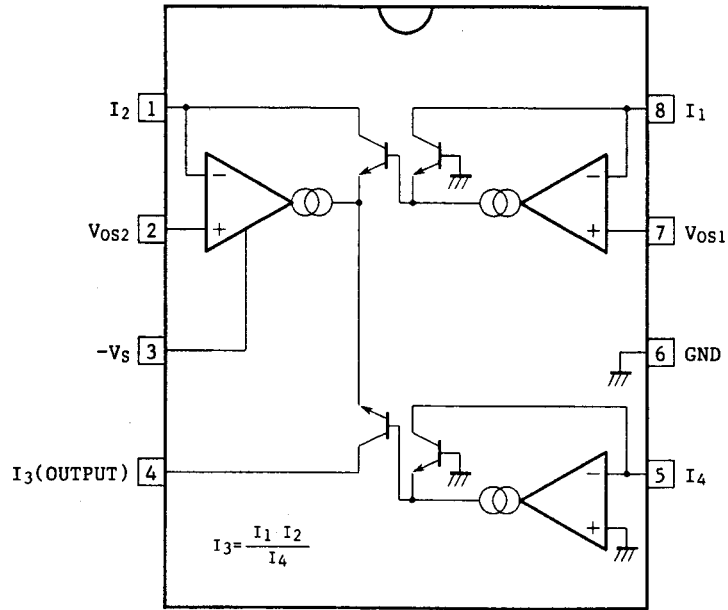

■ GP1U501V (IC951)

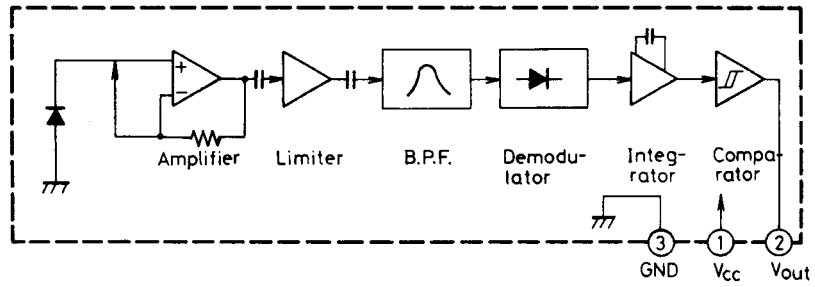

Removal Procedures

■ Removing the Top Cover

1. Remove the eight screws from the top plate to remove the top cover.
2. Remove the eight screws from the left and right side panels, and remove the two screws from the rear.

■ Removing the Bottom Plate

1. Remove the screws holding the four feet and remove them.
2. Remove all 30 screws holding the bottom plate to remove the bottom plate.

■ Removing the Front Panel

1. Remove the top cover. (Refer to the previous procedure.)
2. Pull off the volume knob.
3. Remove the two plastic rivets (A) holding the lamp housing for the "Digital Pure-A" indicator.
4. Take out the two lamps for the "D/A CONVERTER DIRECT" indicator and the three lamps for the "sampling frequency" indicators.
5. Remove the six screws holding the front panel (three screws on the top and bottom) and gently take off the front panel.

■ Removing the Side Brackets

When disassembling this unit, first remove the side brackets or front panel as shown in Fig. 3, to make subsequent disassembling of each section smooth.

1. Remove the front panel. (Refer to the previous procedure.)
2. Remove the three screws ((B) or (C)) holding the right or left side bracket.
3. Remove the three screws holding the side bracket to the bottom. (At this time, the feet should be removed.)
4. Remove the screws holding the jacks and terminals to the rear panel.
5. Take out the wires and connectors as required.

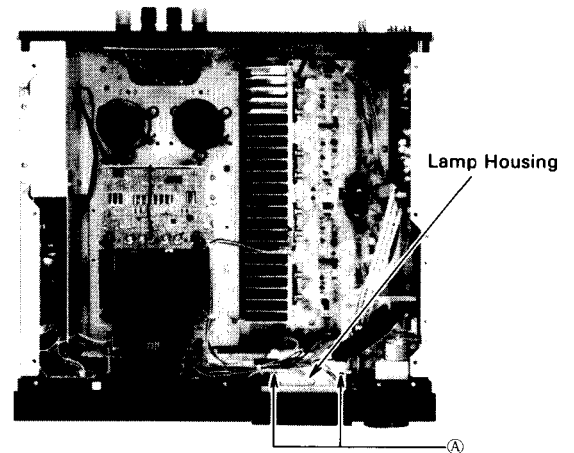

Fig. 1

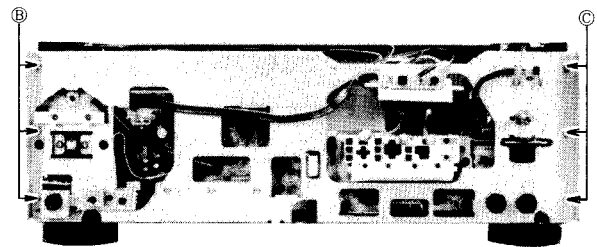

Fig. 2

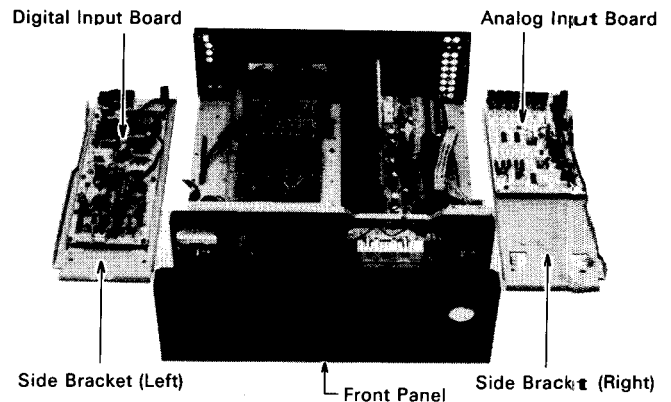

Fig. 3

Adjustment Procedures

Note: In this unit, since the power supply board is directly connected to the power transformer, be especially careful not to touch the soldered surface when servicing.

■ Power Amplifier Center Voltage Adjustment

1. Before applying a signal, first set the adjusting VRs R405 and R406 to their center points.
2. Adjust R405 (L-channel) and R406 (R-channel) until the voltage between pins ⑤ and ③ (for the L-channel) and pins ① and ③ (for the R-channel) of TP401 is 0 ± 5 mV.

■ Idling Adjustment

Note: Before starting this adjustment, be sure to disconnect the probes and the metallic case of the measurement instruments used for this adjustment from the ground of this unit (AX-Z911BK), or from other measurement instruments, so that they are independent from this unit.

1. Before applying a signal, first rotate the adjusting VRs R461, R462, R457 and R458 fully counterclockwise.
2. Connect a CD player having an optical digital out connector (such as the XL-Z444BK) to the DIGITAL-1 input jack of this unit.

3. Load the test disc (CRG-1106) in the CD player and play the 6th track ($-\infty$ dB, digital 0).

(1) Idling adjustment for "Dynamic Super-A":

1. Set the source selector to a position other than DIGITAL-1.
2. Adjust R461 (L-ch) and R462 (R-ch) until the voltage between pins ④ and ⑤ (for the L-channel) and pins ② and ① (for the R-channel) of TP401 is 0.48 or $[1.30]$ mV a half minute after the signal is applied, and is 2.7 or $[3.3]$ mV five minutes later.

(2) Idling adjustment for "Digital Pure-A":

1. Set the source selector to the DIGITAL-1 position.
2. Adjust R457 (L-ch) and R458 (R-ch) until the voltage between pins ④ and ⑤ (for the L-channel) and pins ② and ① (for the R-channel) of TP401 is 80 mV one minute after the signal is applied, and 150 mV five minutes later.

* Perform adjustments (1) and (2) sequentially for each channel, and after this check the "Dynamic Super-A" idling.

Note: \square for the U.S.A and Canada
 [] except for the U.S.A and Canada

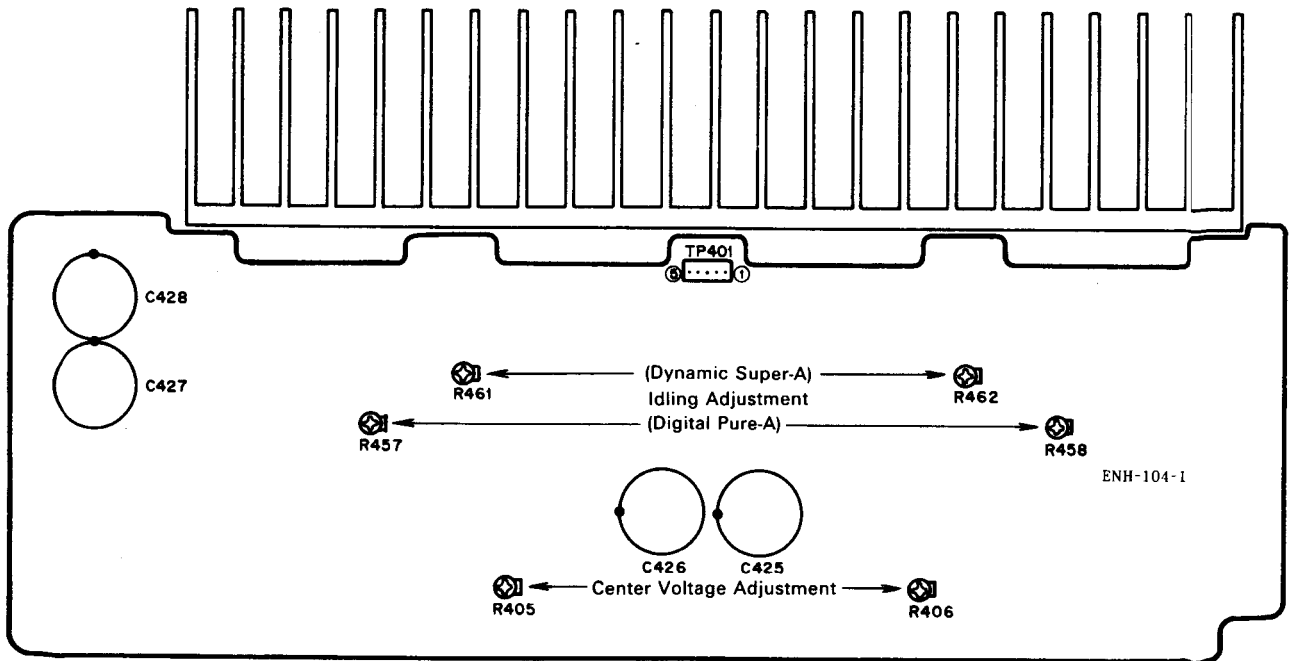

■ D/A Converter Adjustment (MSB Adjustment)

1. Connect the digital output of a CD player (such as the XL-Z444BK) to the DIGITAL INPUT jack of this unit, and also connect an amplifier device and oscilloscope to the DAT/TAPE 1 "REC OUT" jacks.
2. Load the test disc (CRG-1106) in the CD player, and play the 9th track (1 kHz, -60 dB).
3. Insert an insulated screwdriver, having a 1.5 mm flat blade, into the adjusting hole on the left side bracket, and adjust R202 until the waveform shows the correct sine wave.

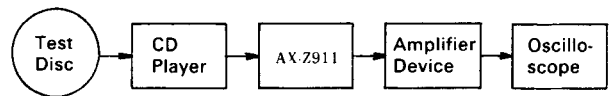

* For the amplifier device, refer to the XL-Z444BK Service Manual (No. 20034)

■ "Digital Pure-A" Operating Point Adjustment

1. Before applying a signal, rotate the adjusting VR R785 fully counterclockwise beforehand.
2. Connect the digital output of a CD player (such as the XL-Z444BK) to the DIGITAL INPUT jack of this unit, and apply a 1 kHz, 0 dB signal (sine wave, both channels).
3. Adjust the master volume of this unit until a sine wave of 1 kHz and 12.5 V is present at the speaker terminals.
4. With this condition, gradually rotate R785 clockwise until LEDs D734 and D735 light continuously.

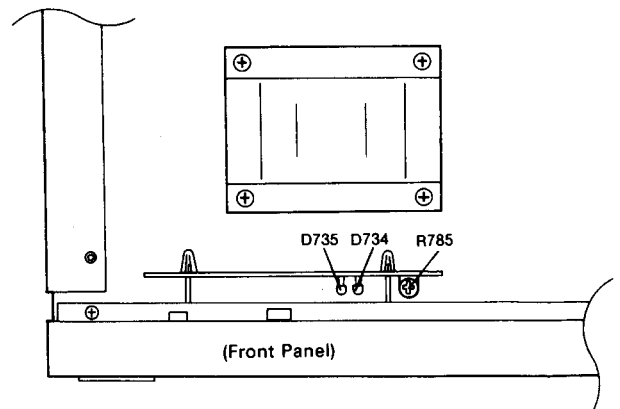
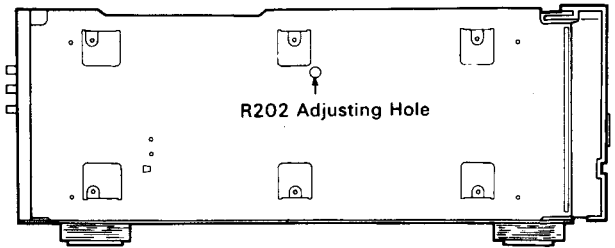

[Reference]

D734 and D735 indications

When LEDs D734 or D735 light or go out, it shows the following conditions for the output stage of this unit:

D734	Indicating the power voltage supply to the output stage	Lights: High power voltage ... Vcc H 100 watts*
		Not lit: Low power voltage ... Vcc L 20 watts
D735	Indicating the idling current for the output stage	Lights: Low idling current ... Dynamic Super-A
		Not lit: High idling current ... Digital Pure-A

*: for the U.S.A. & Canada

Therefore, by a combination of the status of D734 and D735, there are four output stage operation modes, as follows, and each of them can be separately used.

Mode	I	II	III	IV
D734	Lights	Lights	Not lit	Not lit
D735	Lights	Not lit	Not lit	Lights
Analog signal reproduction	← High power signal output →		Low power signal output	When the protection circuit is activated due to abnormal temperature (both analog and digital signal reproduction)
Digital signal reproduction	← High power signal output →			
DPA INO ON	← High power signal output →		← Low power signal output →	
Output Operation	100 W* Super A	100 W* PURE A	20 W PURE A	20 W SUPER A
Heating value	Middle	Large	Middle	Small

*: for the U.S.A. & Canada

Example of each mode under temperature compensating operation:

- 1) When heating the lead of R560 (abnormal temperature detecting thermistor) using a soldering iron, the unit enters mode IV operation.
- 2) In low power digital signal reproduction, when the input level is increased to enter the high power output operation, the operation mode is changed in the order, mode III → mode II → mode I. At this time, the transition period from mode II to mode I will be shortened when the temperature of R559 is raised.

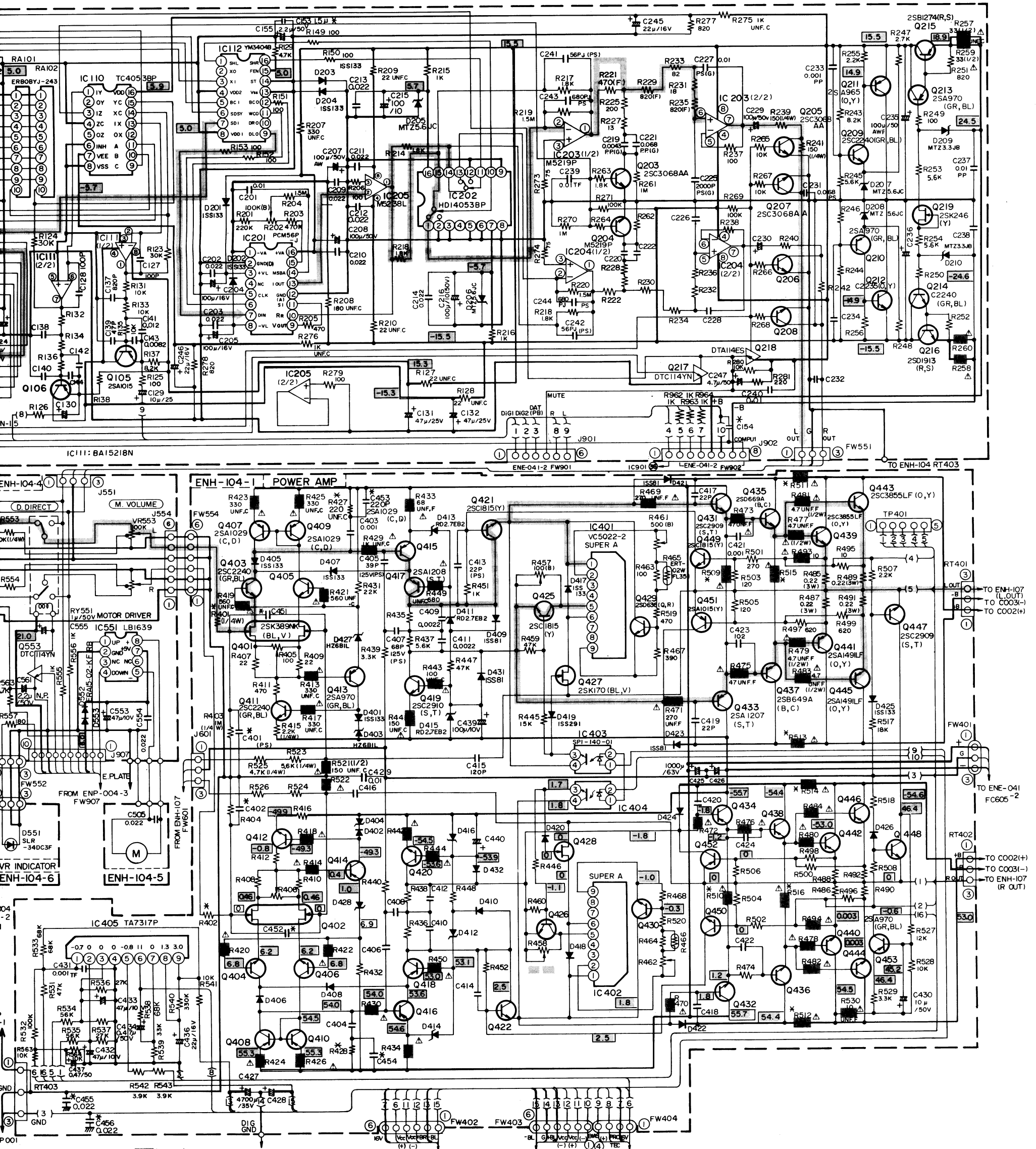

in the darkened area (■) and
 sure to use the designated parts to
 at diagram.
 re subject to change without notice.

Schematic Diagram

Front & Digital Pure "A" Control Section

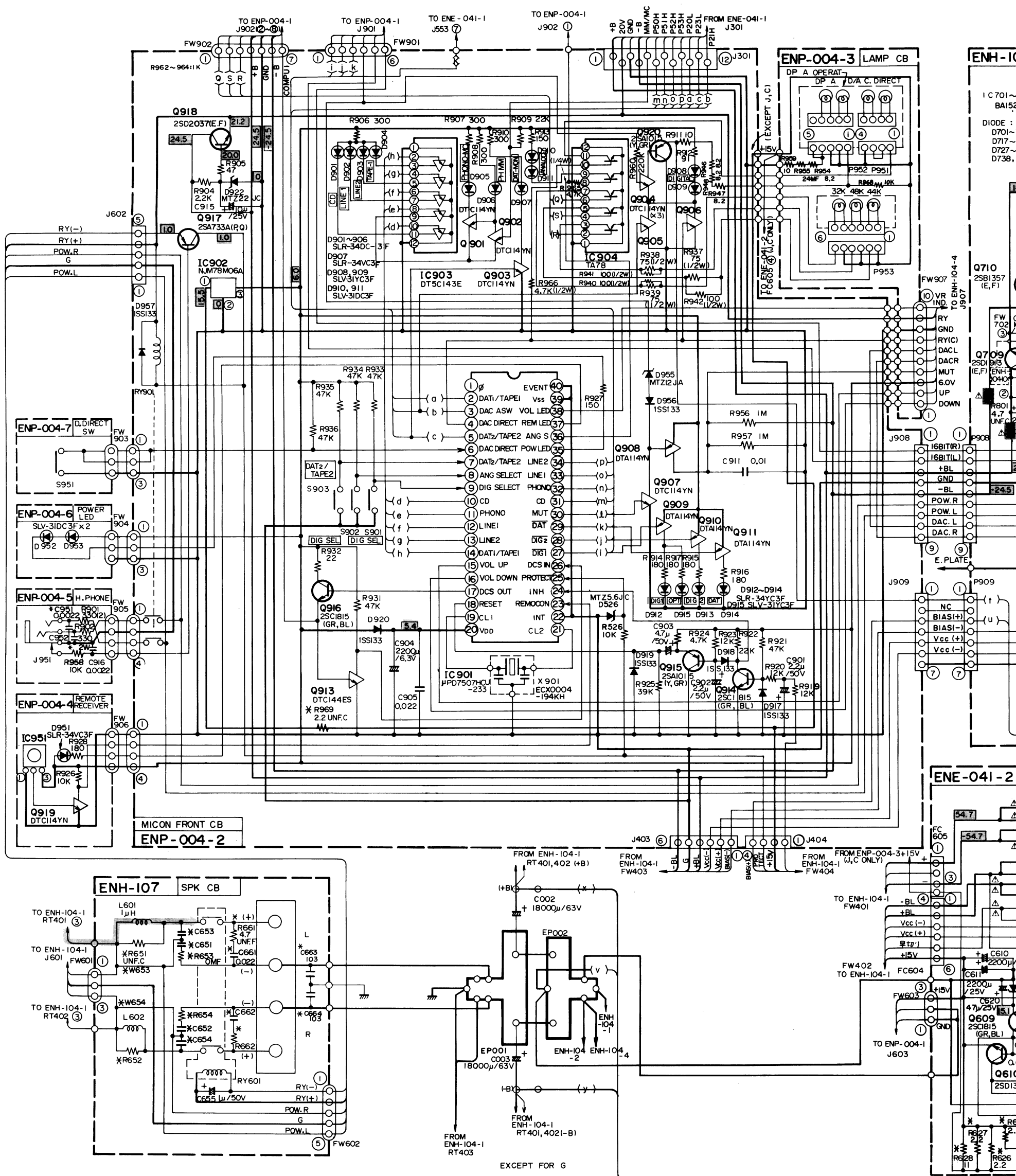

(No. 20058)

MC-Service

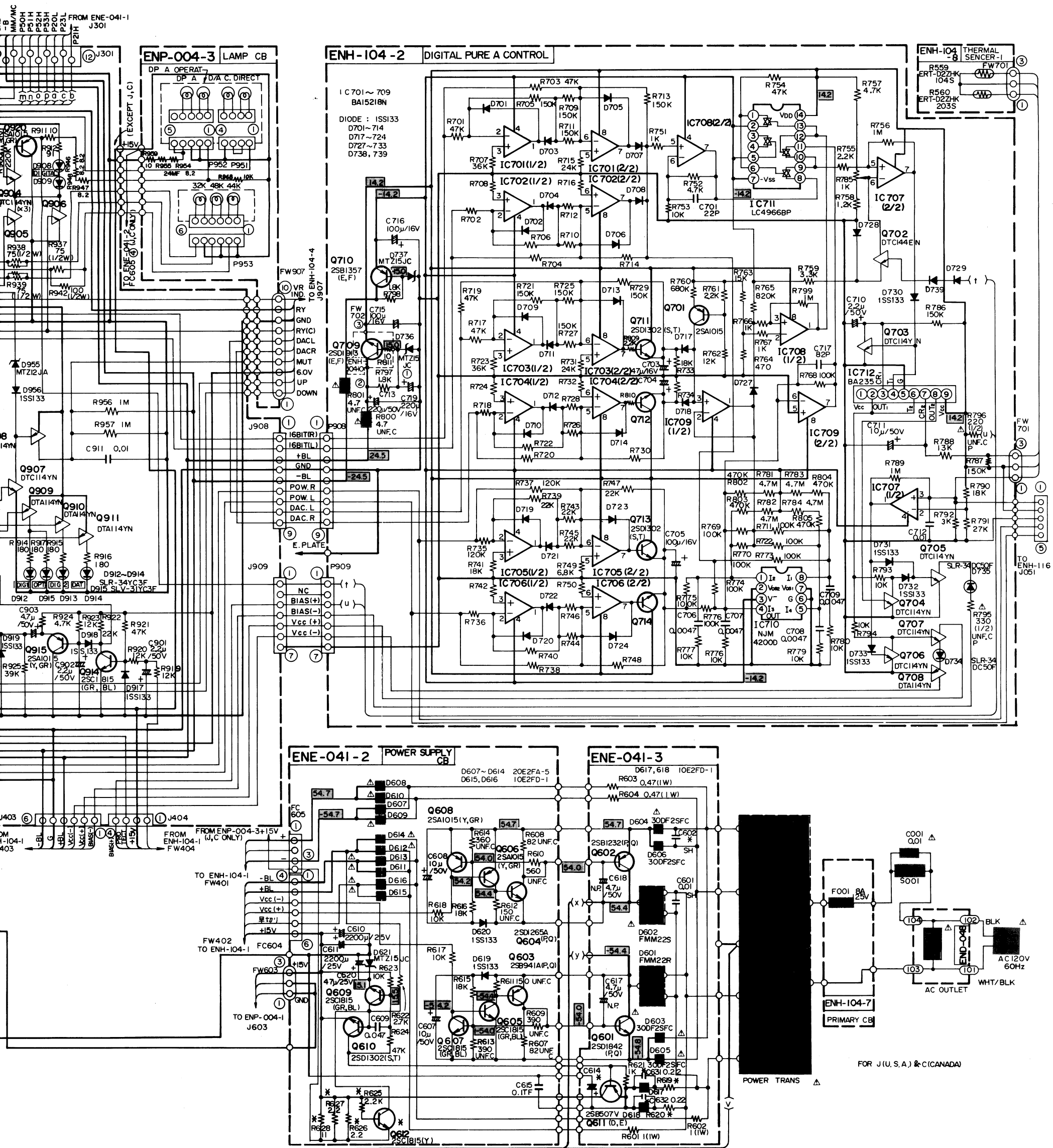

Schematic Diagram

Power Supply Section

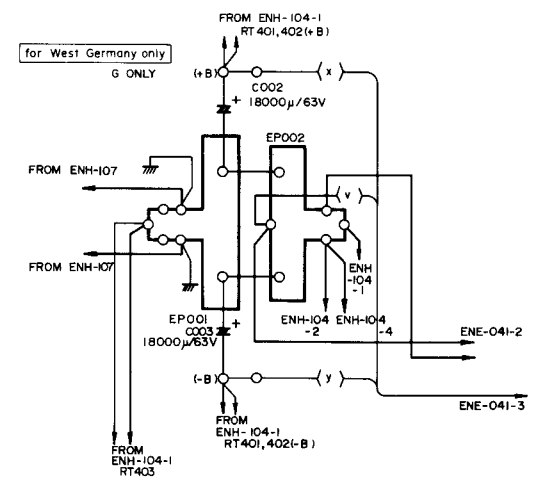
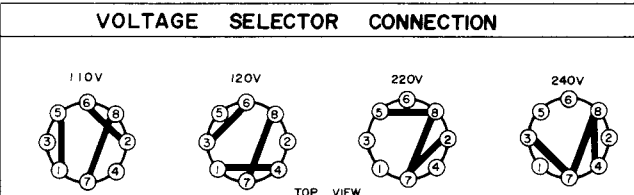
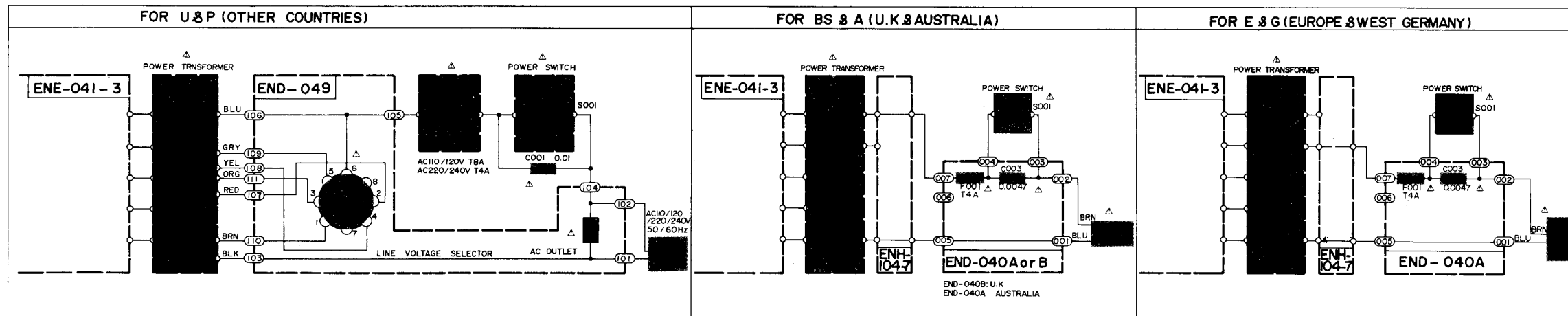
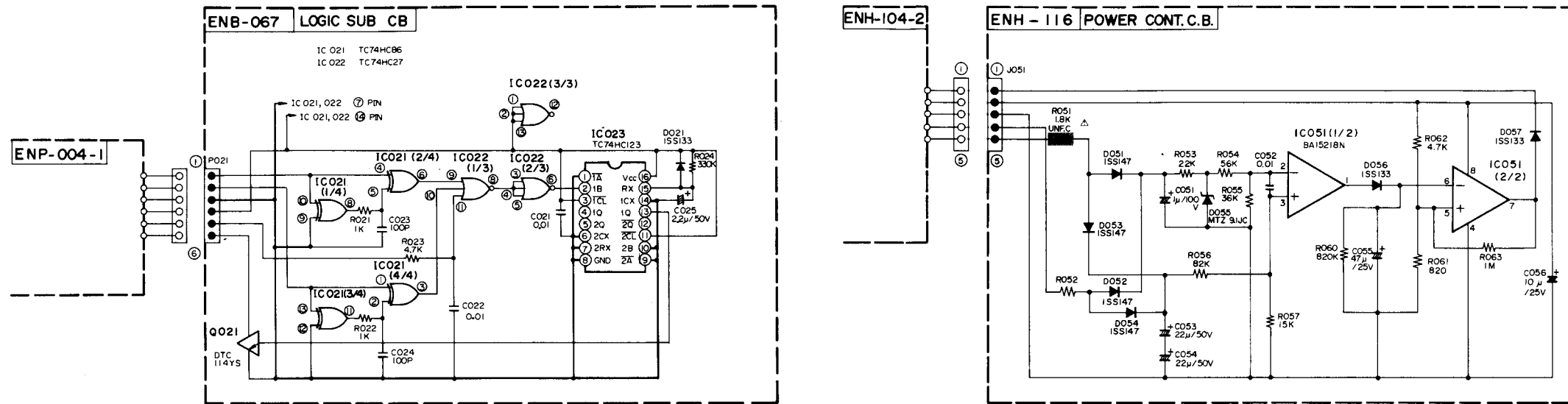

SYMBOL NO	J. C	U. P. PG	E. A. BS	G	SYMBOL NO	J. C	U. P. PG	E. A. BS	G
C351-364	NONE	NONE	NONE	USED	C653, 654	SHORT	0.1	0.1	NONE
L301, 302	NONE	NONE	NONE	USED	R661, 662	NONE	NONE	NONE	USED
C321, 322	NONE	NONE	NONE	USED	C661, 662	NONE	NONE	NONE	USED
R369, 390	SHORT	SHORT	SHORT	USED	C951, 952	NONE	NONE	NONE	USED
C325, 326	NONE	NONE	NONE	USED	R969	USED	USED	USED	SHORT
R509, 510	1K UNF.F	1.8K UNF.F	1.8K UNF.F	1.8K UNF.F	R651, 652	10(1/2)UNF.C	10(1/2)UNF.C	10(1/2)UNF.C	100(1/2)UNF.C
R511-514	10 UNF.C	4.7 UNF.F	4.7 UNF.F	4.7 UNF.F	R653, 654	10(2)10MF	10(2)10MF	10(2)10MF	47(2)10MF
R515, 516	100 UNF.F	270 UNF.F	270 UNF.F	270 UNF.F	W653, 654	NONE	NONE	NONE	USED
C651, 652	0.047	0.1	0.1	0.022	R427, 428	SHORT	SHORT	SHORT	USED
Q612	USED	NONE	NONE	NONE	C334-337	USED	NONE	NONE	USED
R625-628	USED	NONE	NONE	NONE	R401, 402	100	100	100	220
R146	NONE	USED	USED	USED	C401, 402	56P	56P	56P	330P
L104	1μH	NONE	NONE	NONE	C451, 452	68P	68P	68P	100P
R619, 620	0.56(1)M.F	0.22(2)M.F	0.22(2)M.F	0.22(2)M.F	C453, 454	NONE	NONE	NONE	USED
C614	2.2μ/50V	220 μ/35V	220 μ/35V	220 μ/35V	C455, 456	NONE	NONE	NONE	USED
					C123	1.5	0.01	0.01	1.5
					C152, 153	USED	NONE	NONE	USED
					C602	0.01	0.01	0.01	0.022
					C663, 664	NONE	NONE	NONE	USED
					C151	220P	220P	220P	470P
					C154	NONE	NONE	NONE	100P
					R140	220	220	220	470
					C365, 366	NONE	NONE	NONE	100P

MC-Service

Schematic Diagram

■ System Control Microcomputer Peripheral Circuit

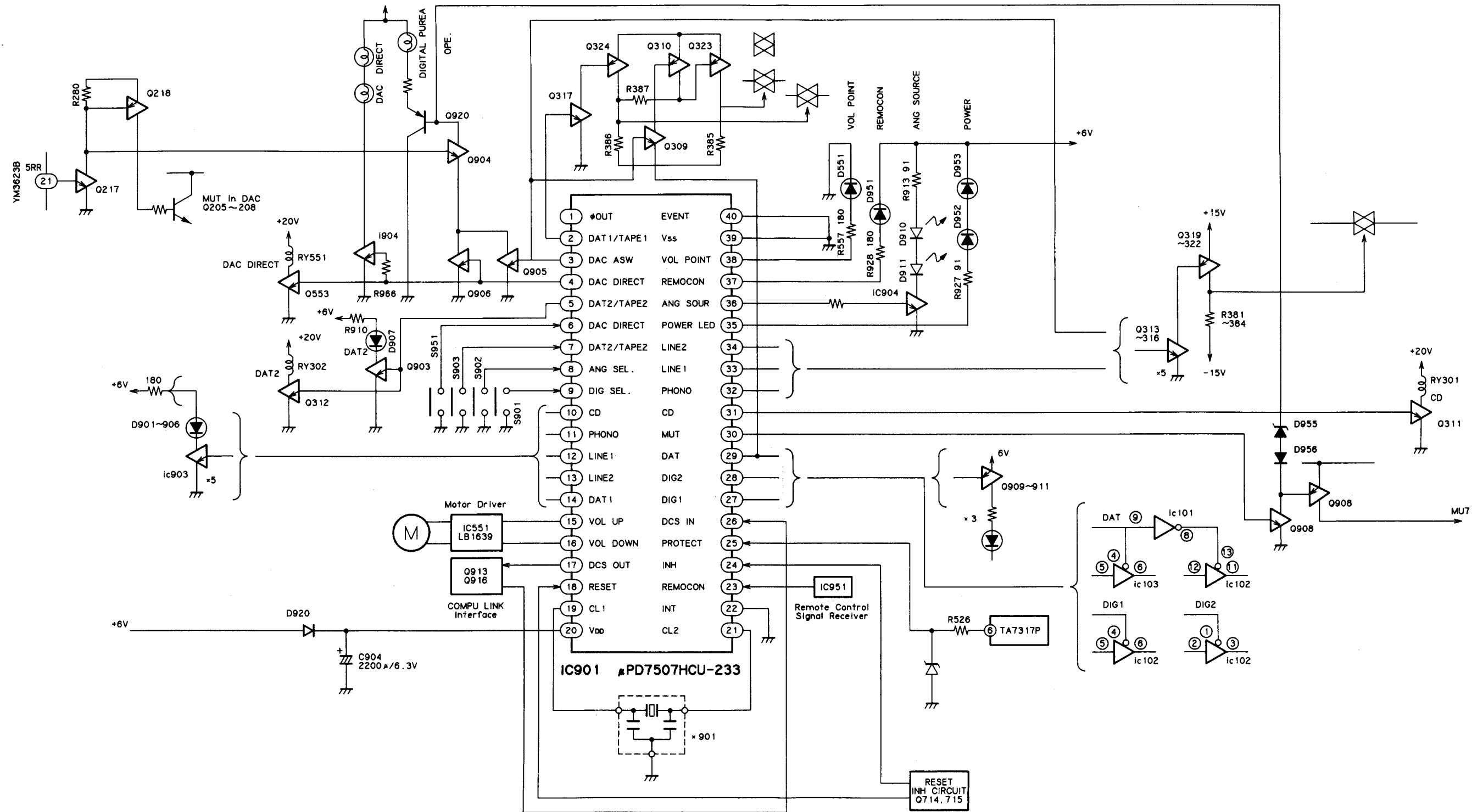

MC-Service

Block Diagram

■ Signal Circuit

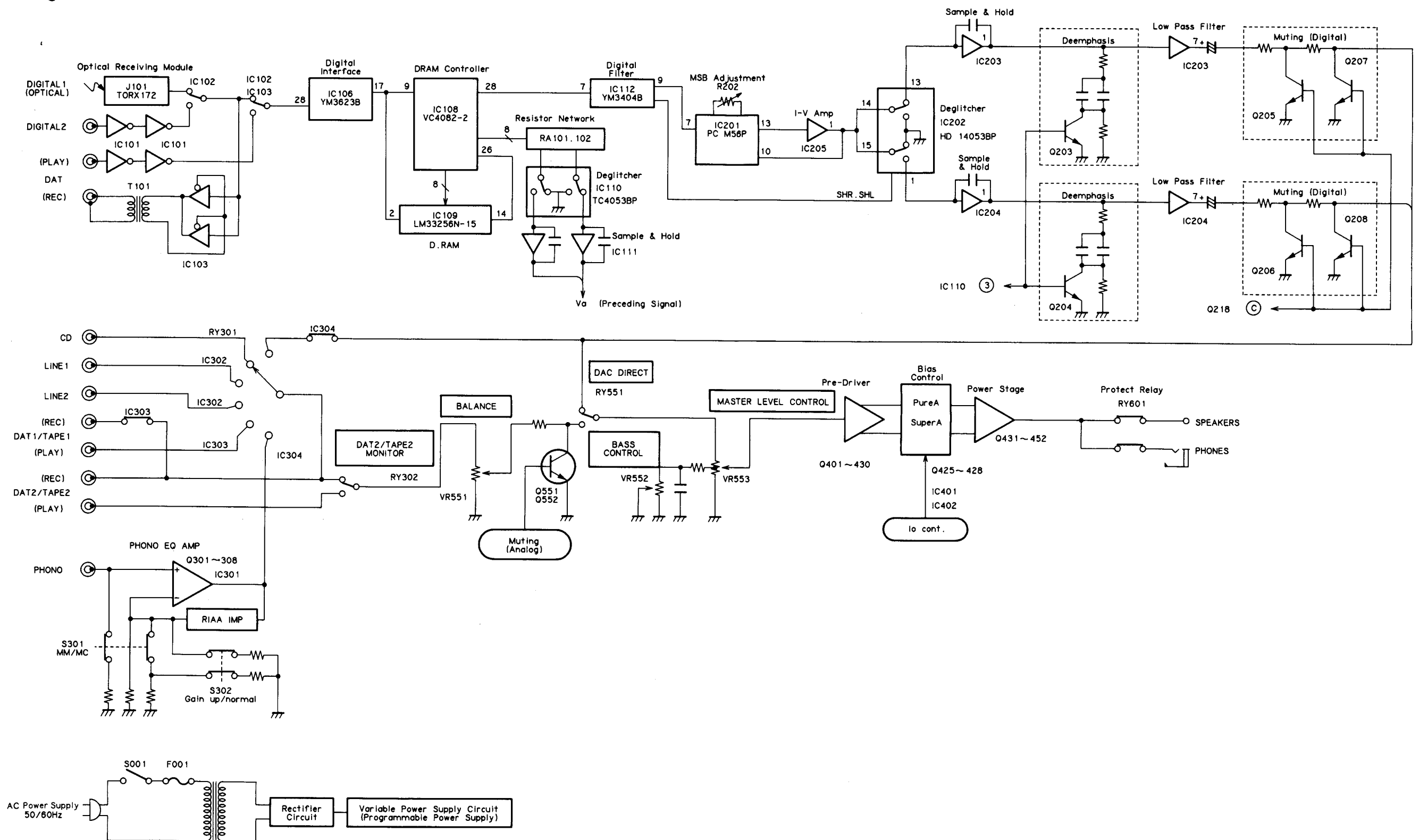

Connection Diagram

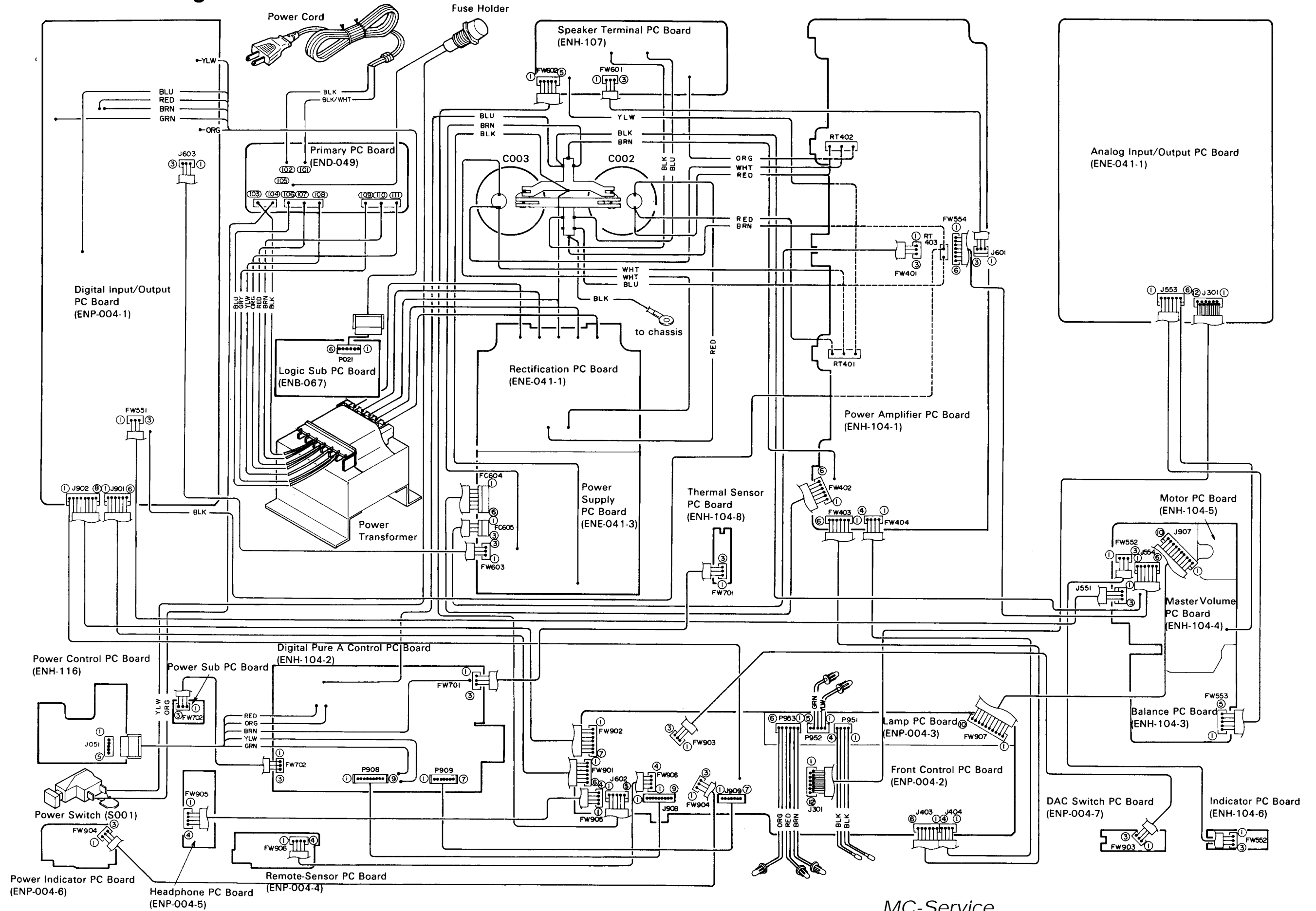

MC-Service

Troubleshooting

No.	Symptom	Check Points
1	Relay does not turn on	1) FW501 2) J403 3) FC604 4) FW601 5) Q918 6) FW401 7) FW601 8) J554 9) FW602 10) Short circuit between Q485 and C411 11) FC605 12) Q334 13) Q331 14) Q332 15) Q333 16) FW403 17) IC304 18) D329
2	Relay turns on quickly	1) C436
3	No sound from right channel	1) J602 2) RY551 3) RY601
4	No sound from left channel	1) J602 2) RY603
5	No sound from right channel at CD input	1) RY301
6	No headphone sound from right channel	1) J602 2) FW905
7	No sound	1) FW401 2) FW602 3) J907 4) BA235 5) J602 6) RY601 7) RY001
8	No sound at Digital input	1) IC108 2) FW603 3) J403 4) X101 5) J901 6) J101

(No. 20058)

No.	Symptom	Check Points
20	Relay turns off when increasing the volume	1) R397
21	Phono relay(RY302) does not turn on	1) R312 2) FW508 3) J554 4) J553
22	Source does not change	1) FW907 2) IC901
23	Poor distortion at Digital input	1) IC201 2) IC203 3) Q218 4) FW551 twist 5) IC204 6) Q203 7) Q216
24	Sampling frequency 32kHz lights continuously	1) IC904
25	Volume rotates to decrease automatically	1) J907
26	Center offset no regulation	1) Q438 2) Q402 3) Q401 4) J601
27	Oscillation from left channel	1) C149 2) C441 3) R651
28	Oscillation from right channel	1) R652
29	Poor distortion from right channel	1) C412
30	Poor distortion from left channel	1) C411 2) C407 3) C409 4) R511
31	Volume does not rotate with Remote Controller	1) J907
32	Oscillation at Digital input	1) C413 R469~R472
33	Remote Controller does not function	1) FW906
34	Small Digital output	1) C243 C244

(No. 20058)

No.	Symptom	Check Points
8	No sound at Digital input	7) J602 8) J551 9) J603 10) IC023 11) P021 12) P201 13) L101
9	No sound from right or left channel at Digital input	1) FW553
10	No sound at Phono input	1) IC301 2) D328 3) D326 4) D327 5) D325
11	Sampling frequency display does not light	1) IC022 2) J902 3) FW902 4) P902 5) P953
12	No sound when setting DAC DIRECT switch to on.	1) J907
13	Does not adjust the idling current of left channel	1) Q445 2) R653
14	Does not adjust the idling current of right channel	1) C420 2) Q428 3) R516 4) R514
15	Does not adjust the idling current	1) D601 2) Q601
16	Indicator does not change to Analog	1) J909 2) J908 3) J403
17	Saturation of the negative side of output wave form	1) Q601 2) Q603
18	Saturation of the positive side of output wave form	1) Q604 2) P909 3) R511(Left channel) 4) R512(Right channel)
19	Relay turns off due to the abnormal idling current	1) R653 2) R651 3) C651 4) C417

No.	Symptom	Check Points
35	Compu Link does not function	1) IC901 2) J902
36	Left and right channel reverse	1) J551(FW551)
37	Digital and Analog input selector light at the same time	1) J902
38	Super A does not function	1) J403 2) J901 3) J909 4) Q702 5) IC708 6) J902
39	Pure A does not function	1) IC701

■ Connections between the Control Signal Boards

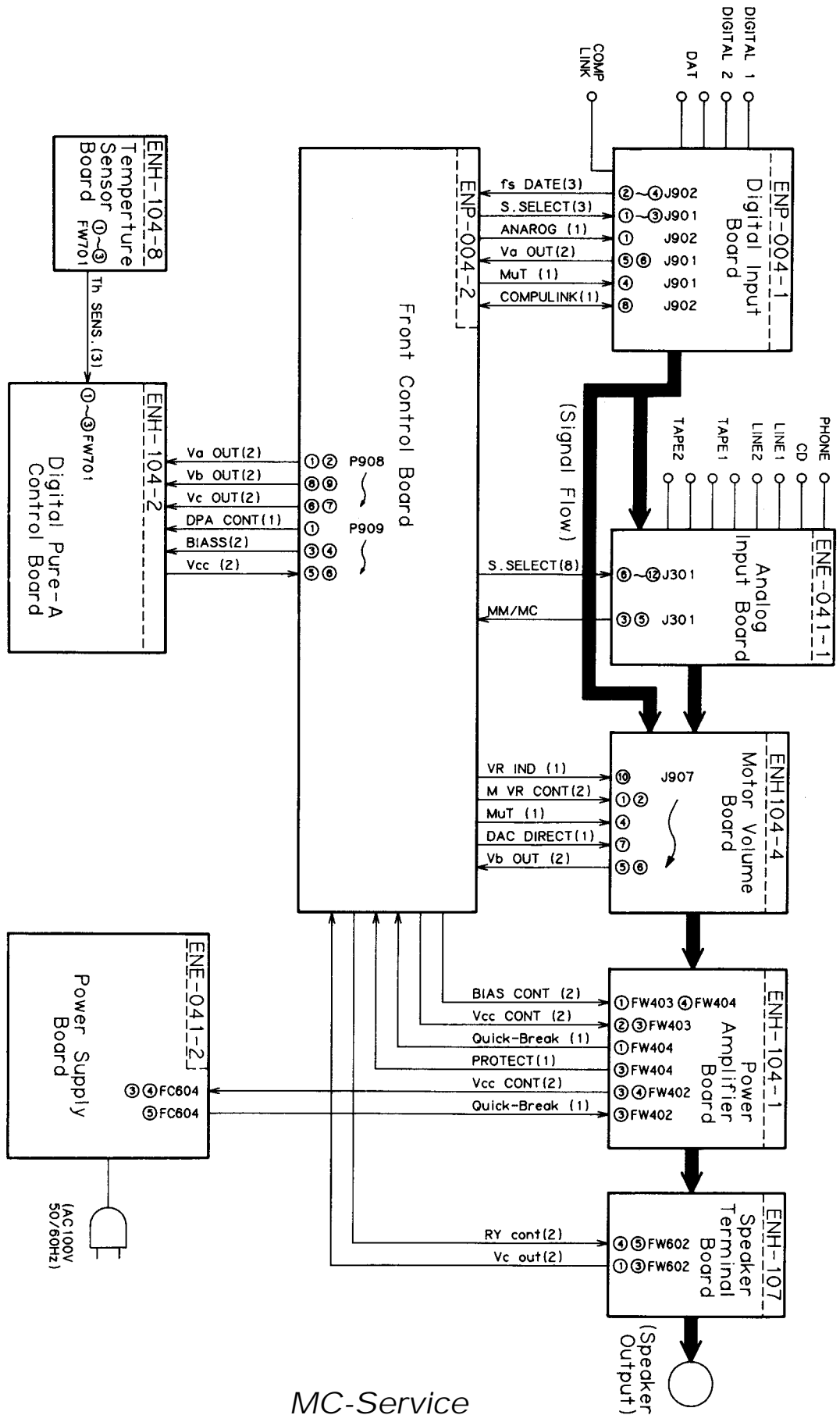

MC-Service



JVC

VICTOR COMPANY OF JAPAN LIMITED
AUDIO PRODUCTS DIVISION, YAMATO PLANT, 1644, SHIMOTSURUMA, YAMATO-SHI, KANAGAWA-KEN, 242, JAPAN

(No. 20058)



Printed in Japan
805 (G)

PARTS LIST

Contents

Main Parts Locations	2-2
Exploded View and Parts List.....	2-3
Printed Circuit Board Ass'y and Parts List.....	2-7
■ ENH-104 □ Power Amplifier PC Board Ass'y.....	2-7
■ ENP-004 □ Digital Front PC Board Ass'y	2-12
■ ENE-041 □ Analog Input / Output PC Board Ass'y	2-16
■ ENB-067 [B] Logic PC Board Ass'y.....	2-19
■ ENH-116 [A] Power Control PC Board Ass'y.....	2-20
■ END-049 [A] Voltage Selector PC Board Ass'y.....	2-20
■ ENH-107 □ Speaker PC Board Ass'y	2-21
■ END-048 [A] AC Outlet PC Board Ass'y.....	2-21
■ END-040 □ Primary PC Board Ass'y	2-22
Packing Materials and Parts Numbers.....	2-23
Accessories List.....	2-24

Main Parts Locations

■ Front View

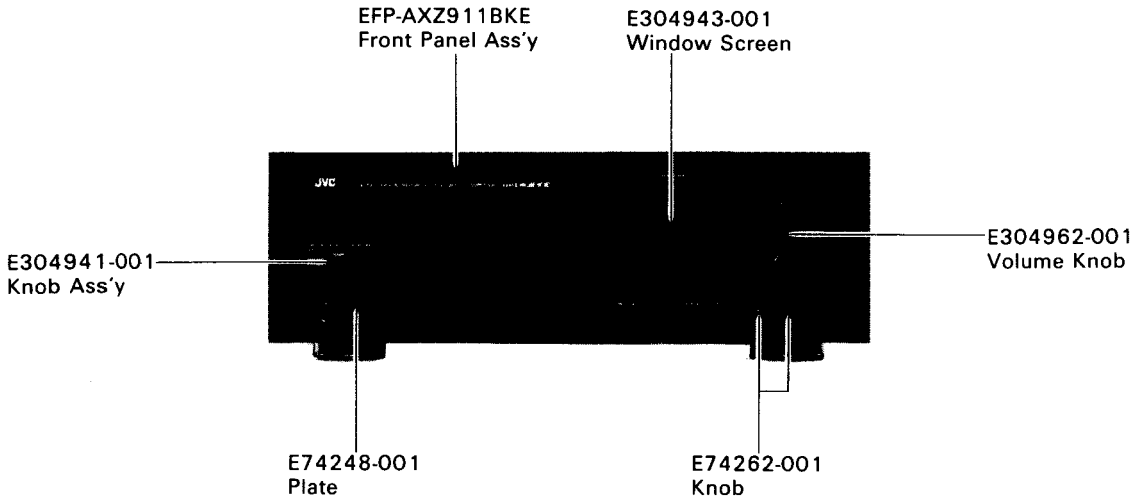

■ Top View

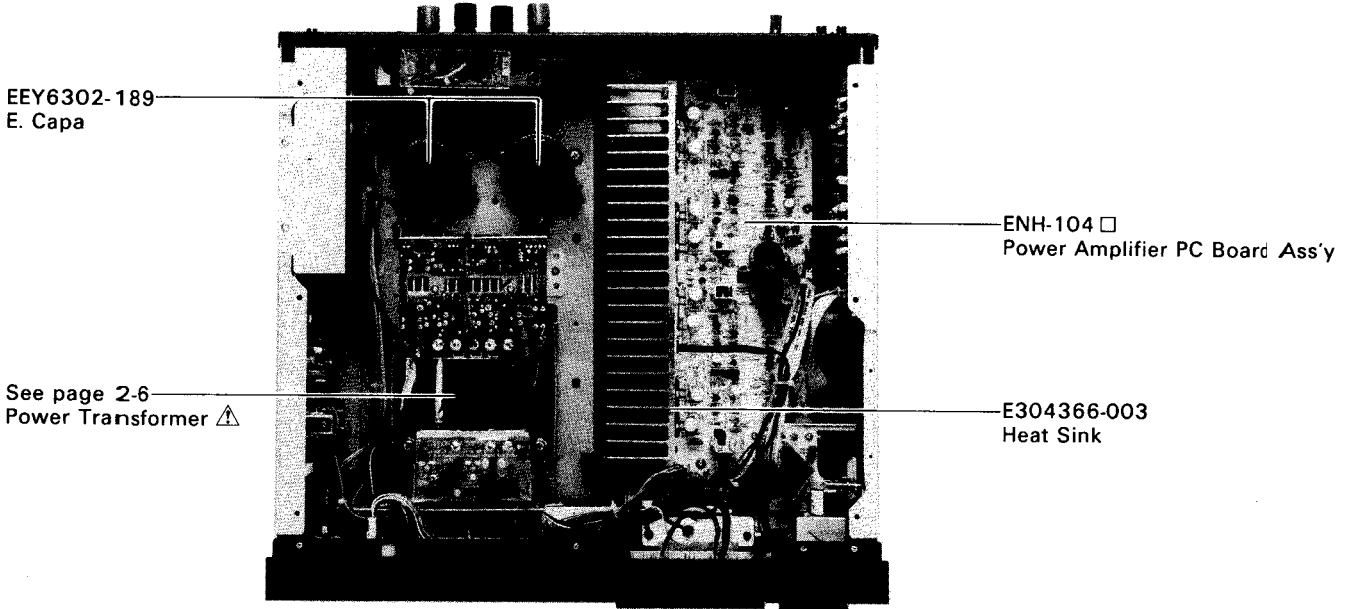

■ Rear View

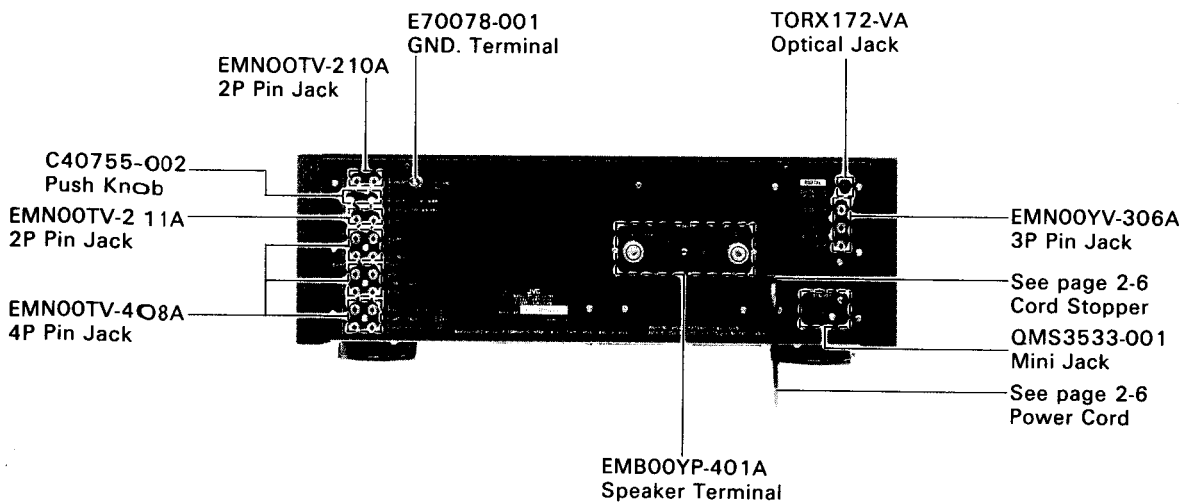

⚠: Safety Parts

Exploded View and Parts List

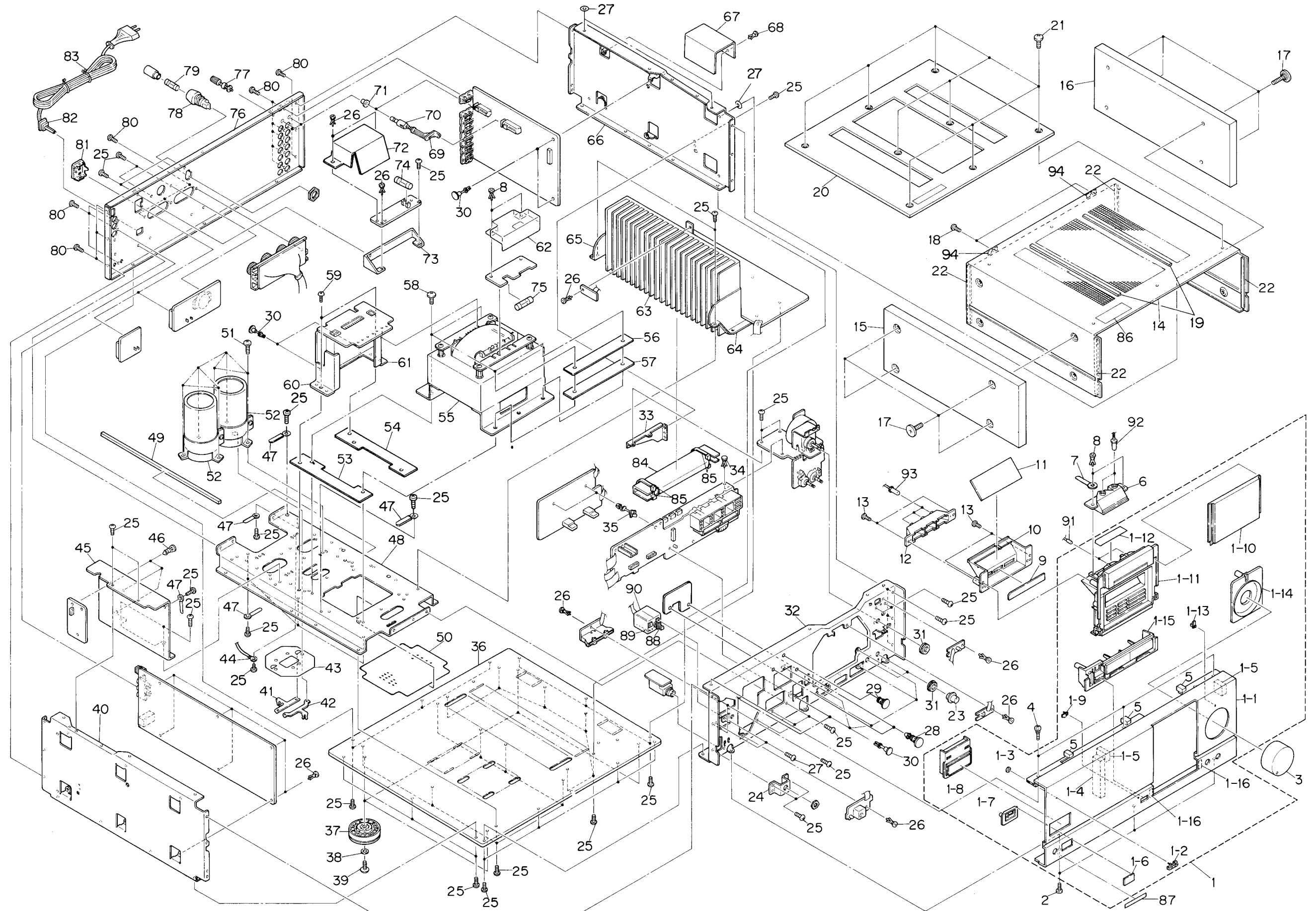

△	Item	Part Number	Part Name	Q'ty	Description	Areas
	1	FEP-AXZ911BKE	Front Panel Ass'y	1		
	1-1	E11534-002	Front Panel	1		
	1-2	E70913-001	JVC Mark	1		
	1-3	E60912-003	Speed Nut	1		
	1-4	E3400-392	Felt Spacer	1		
	1-5	E3400-391	Felt Spacer	2		
	1-6	E74248-001	Plate	1		
	1-7	E74250-002	Remocon Escutcheon	1		
	1-8	E304941-001	Knob Ass'y	1		
	1-9	E74259-002	Indicator	1		
	1-10	E304943-001	Window Screen	1		
	1-11	E25763-002	Front Escutcheon Ass'y	1		
	1-12	E74318-003	Sheet	1		
	1-13	E24259-001	Indicator	1		
	1-14	E304949-002	Knob Ring	1		
	1-15	E304951-001	Knob Ass'y	1	Source	
	1-16	EXO015005R02S	Spacer	2		
	2	SDS83008MCP	Screw	3		
	3	E304962-001	Volume Knob	1		
	4	E66052-006	Special Screw	3		
	5	EXO015008R60S	Spacer	3		Except J, C
	6	EXO015008R60S10	Spacer	3		J, C
	7	E304945-001	Lamp House	1		
	8	E50670-005	Wire Clamp	1		
	8	E48729-007	Plastic Rivet	4		Except U, P, PG
	9	E48729-007	Plastic Rivet	2		U, P, PG
	9	E74253-001	Sheet	1		
	10	E304948-001	Back Cover	1		
	11	E74255-005	Mirror	1		
	12	E304946-001	Lamp House	1		
	13	SBSF3008Z	Screw	4		
	14	E25766-003	Metal Cover	1		
	15	ED37916-001	Side Wood	1	Left	
	16	ED37916-002	Side Wood	1	Right	
	17	ED44071-002	Special Screw	8		
	18	SBSB3008MCP	Scerw	2		
	19	EXO210008H03S	Spacer	2		
	20	E25767-002	Top Plate	1		
	21	SDST4008M	Screw	8		
	22	EXO13004R20S10	Spacer	4		
	23	E74262-001	Knob	2		
	24	E74264-001	Head Phone Bracket	1		
	25	SBSE3008CC	Screw	58		J, C
	25	SBSE3008CC	Screw	59		U, P, PG
	25	SBSE3008CC	Screw	60		A, E, EF, BS
	26	SBSE3008CC	Screw	62		G
	26	E48729-008	Plastic Rivet	14		Except J, C, U, P, PG
	26	E48729-008	Plastic Rivet	11		J, C, U, P, PG
	27	E46891-032	Plate	6		G
	28	E303216-002	Fastener	2		
	29	E305536-001	Fastener	1		
	30	E48729-019	Plastic Rivet	10		
	31	E71862-001	Volume Nut	3		
	32	E11540-003	Front Bracket	1		
	33	E74307-001	Circuit Board Bracket	1		
	34	E48729-017	Plastic Rivet	1		
	35	E72631-006	Fastener	2		
	36	E11538-002	Bottom Cover	1		
	37	E74205-002	Foot Ass'y	4		
	38	WNS4000CC	Washer	4		
	39	E61661-005	Screw	4		
	40	E11537-001	Frame	1	Left	
	41	E73690-001	Earth Plate	1		
	42	E73689-001	Earth Plate	1		
	43	E74406-002	Sheet	1		
	44	EWT011-108	T. Wire Ass'y	2		G
	44	EWT011-108	T. Wire Ass'y	1		Except G
	45	E304975-003	Shield Cover	1		
	46	E303216-001	Fastener	3		
	47	E72018-001	Wire Clamp	6		Except J, C

△ : Safety Parts

△	Item	Part Number	Part Name	Q'ty	Description	Areas
	48	E72018-001	Wire Clamp	7		J, C
	48	E11536-003	Trans Base	1		
	49	EXO270005N60S02	Felt Spacer	1		
	50	E74750-001	Protect Cover	1		
	51	SDST4010CC	Screw	6	E.Capa	
	52	EY6302-189	E. Capa	2	C002, C003	
	53	E74916-001	Spacer	1		
	54	E74916-002	Spacer	1		
△	55	ETP1300-04JA	Power Transformer	1		J, C
△	55	ETP1300-04FA	Power Transformer	1		U, P, PG
△		ETP1300-04EA	Power Transformer	1		A, E, EF
△		ETP1300-04XA	Power Transformer	1		G
△		ETP1300-04EABS	Power Transformer	1		BS
	56	E74914-001	Bracket	2		
	57	E74915-001	Spacer	2		
	58	SDST4014CC	Screw	4		
	59	SBSE3010CC	Screw	2		
	60	E305014-003	Heat Sink Bracket	1	Left	
	61	E305014-004	Heat Sink Bracket	1	Right	
	62	E305535-001	Cover	1		Except U, P, PG
	63	E304366-003	Heat Sink	1		
	64	E304952-001	Heat Sink Bracket	1	Front	
	65	E304952-002	Heat Sink Bracket	1	Rear	
	66	E11537-002	Farne	1	Right	
	67	E74809-001	Shield Bracket	1		G
	68	E48729-009	Plastic Rivet	1		G
	69	E69337-001	Push Shaft	1		
	70	E66226-001	Push Shaft	1		
	71	C40755-002	Push Knob	2		
	72	E72922-003	Cover	1		A, E, EF, G, BS
△	73	E71074-002	Bracket	1		A, E, EF, G, BS
△	74	QMF51A2-4R0S	Fuse	1		A, E, EF, G
△	74	QMF51E2-4R0SBS	Fuse	1		BS
△	75	QMF61U1-BR0	Fuse	1	F001	J, C
△	76	E25764-002	Rear Panel	1		J, C
		E25764-003	Rear Panel	1		U, P, PG
		E25764-004	Rear Panel	1		A, E, EF, G, BS
		E303260-143	Rating Label	1		E, EF, G
		E70078-001	GND. Terminal	1		
		QMG0301-003	Fuse Holder	1		U, P, PG
△	79	QMF51A2-4R0S	Fuse	1		U, PG
△	79	QMF51A2-4R0L	Screw	1		P
△	80	E73273-003	Special Screw	22		
△	81	QMC0242-005C	AC Outlet	1		J, C
△	81	QMC0242-006C	AC Outlet	1		U, P, PG
△	82	QHS3771-108	Cord Stopper	1		Except BS
△	82	QHS3771-108BS	Cord Stopper	1		BS
△	83	QMP1480-200H	Power Cord	1		J, C
△	83	QMP7600-200	Power Cord	1		U, P, PG
△	83	QMP3900-200	Power Cord	1		E, EF
△		QMP2560-244	Power Cord	1		A
△		QMP39A0-200	Power Cord	1		G
△		QMP9017-008BS	Power Cord	1		BS
	84	E73684-001	Wire Cover	1		
	85	E33754-002	Tie Band	2		
	86	E67000-005	Caution Label	1		
	87	E49267-001	Origin Marking Label	1		BS
	88	QSP1106-005	Push Switch	1	Power S001	Except BS
	88	QSP1106-005BS	Push Switch	1	Power S001	BS
	89	QCZ9046-103	C.Capa	1	C001	J, C, U, P, PG
	90	E67520-002	Switch Cover	1		
	91	E03872-024	Lamp Ass'y	1		
	92	E03872-026	Lamp Ass'y	1		
	93	ELPA001-002	Lamp Ass'y	1		
	94	E74976-001	Spacer	2		G

The Marks for Designated Areas

J.....U.S.A.	G.....West Germany
C.....Canada	BS.....U.K.
P, PG.....U. S. Military Market	U.....Other Countries
E, EF.....Continental Europe	No mark indicates all areas.
A.....Australia	

△ : Safety Parts

Printed Circuit Board Ass'y and Parts List

■ ENH-104 □ Power Amplifier PC Board Ass'y

Note: ENH-104 □ Varies according to the areas employed. See note (1) when placing an order.

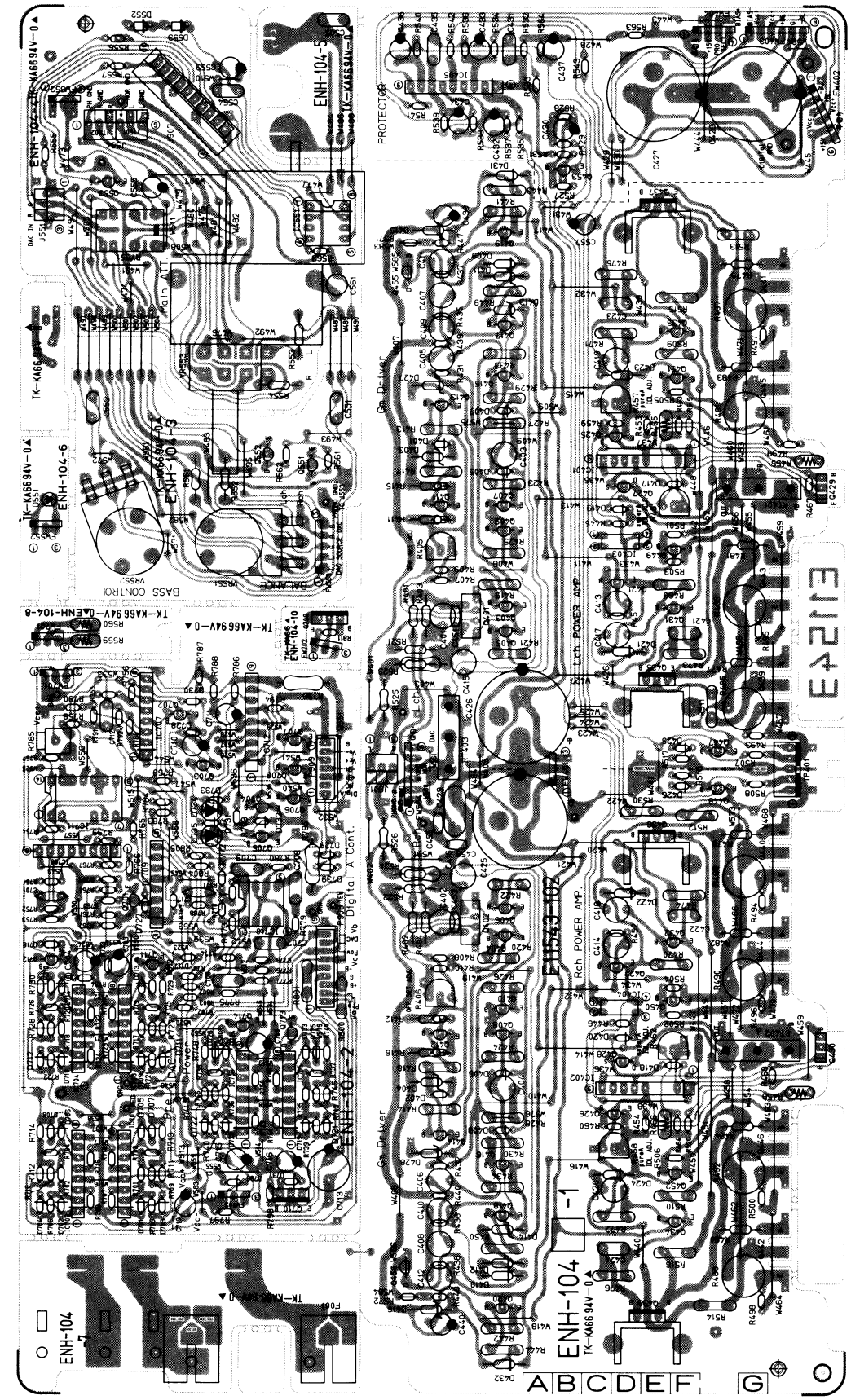

Note (1)

PC Board Ass'y	Designated Areas
ENH-104 B	U.S.A., Canada
ENH-104 C	U.S. Military Market & Other Countries
ENH-104 D BS	U.K.
ENH-104 E	Australia
ENH-104 F	Continental Europe
ENH-104 G	West Germany

ITEM	PART NUMBER	DESCRIPTION	AREA	
			MAKER	
Q401	2SK389(BL,V)	F.E.T	TOSHIBA	
Q402	2SK389(BL,V)	F.E.T	TOSHIBA	
Q403	2SC2240(GR,BL)	SILICON	TOSHIBA	
Q404	2SC2240(GR,BL)	SILICON	TOSHIBA	
Q405	2SC2240(GR,BL)	SILICON	TOSHIBA	
Q406	2SC2240(GR,BL)	SILICON	TOSHIBA	
Q407	2SA1029(C,D)	SILICON	HITACHI	
Q408	2SA1029(C,D)	SILICON	HITACHI	
Q409	2SA1029(C,D)	SILICON	HITACHI	
Q410	2SA1029(C,D)	SILICON	HITACHI	
Q411	2SC2240(GR,BL)	SILICON	TOSHIBA	
Q412	2SC2240(GR,BL)	SILICON	TOSHIBA	
Q413	2SA970(GR,BL)	SILICON	TOSHIBA	
Q414	2SA970(GR,BL)	SILICON	TOSHIBA	
Q415	2SA1029(C,D)	SILICON	HITACHI	
Q416	2SA1029(C,D)	SILICON	HITACHI	
Q417	2SA1208(S,T)	SILICON	SANYO	
Q418	2SA1208(S,T)	SILICON	SANYO	
Q419	2SC2910(S,T)	SILICON	SANYO	
Q420	2SC2910(S,T)	SILICON	SANYO	
Q421	2SC1815(Y)	SILICON		
Q422	2SC1815(Y)	SILICON		
Q425	2SC1815(Y)	SILICON		
Q426	2SC1815(Y)	SILICON		
Q427	2SK170(BL,V)	F.E.T	TOSHIBA	
Q428	2SK170(BL,V)	F.E.T	TOSHIBA	
Q429	2SD636(Q,R)	SILICON	MATSUSHITA	
Q430	2SD636(Q,R)	SILICON	MATSUSHITA	
Q431	2SC2909(S,T)	SILICON	SANYO	
Q432	2SC2909(S,T)	SILICON	SANYO	
Q433	2SA1207(T)	SILICON		
Q434	2SA1207(T)	SILICON		
Q435	2SD669A(B,C)	SILICON	HITACHI	
Q436	2SD669A(B,C)	SILICON	HITACHI	
Q437	2SB649A(B,C)	SILICON		
Q438	2SB649A(B,C)	SILICON		
Q439	2SC3855LF(O,Y)	SILICON		
Q440	2SC3855LF(O,Y)	SILICON		
Q441	2SA1491LF(O,Y)	SILICON		
Q442	2SA1491LF(O,Y)	SILICON		
Q443	2SC3855LF(O,Y)	SILICON		
Q444	2SC3855LF(O,Y)	SILICON		
Q445	2SA1491LF(O,Y)	SILICON		
Q446	2SA1491LF(O,Y)	SILICON		
Q447	2SC2909(T)	SILICON		
Q448	2SC2909(T)	SILICON		
Q449	2SC1815(Y)	SILICON		
Q450	2SC1815(Y)	SILICON		
Q451	2SA1015(Y)	SILICON		
Q452	2SA1015(Y)	SILICON		
Q453	2SA970(GR,BL)	SILICON	TOSHIBA	
Q551	2SC3068	SILICON	SANYO	
Q552	2SC3068	SILICON	SANYO	
Q553	DTC114YN	SILICON	ROHM	
Q701	2SA1015(Y)	SILICON		
Q702	DTC144EN	SILICON	ROHM	
Q703	DTC114YN	SILICON	ROHM	
Q704	DTC114YN	SILICON	ROHM	
Q705	DTC114YN	SILICON	ROHM	
Q706	DTC114YN	SILICON	ROHM	
Q707	DTC114YN	SILICON	ROHM	
Q708	DTA114YN	SILICON	ROHM	
Q709	2SD1913(R,S)	SILICON	SANYO	
Q710	2SB1357(E,F)	SILICON	ROHM	
Q711	2SD1302(S,T)	SILICON	MATSUSHITA	

TRANSISTORS				
ITEM	PART NUMBER	DESCRIPTION	AREA	
			MAKER	
Q712	2SD1302(S,T)	SILICON	MATSUSHITA	
Q713	2SD1302(S,T)	SILICON	MATSUSHITA	
Q714	2SD1302(S,T)	SILICON	MATSUSHITA	

I. C. S				
ITEM	PART NUMBER	DESCRIPTION	AREA	
			MAKER	
IC401	VC5022-2	I.C.	SANYO	
IC402	VC5022-2	I.C.	SANYO	
IC403	SPI-140-01	I.C.	SANYO	
IC404	SPI-140-01	I.C.	SANYO	
IC405	TA7317P	I.C.	TOSHIBA	
IC551	LB1639	I.C.	SANYO	
IC701	BA15218N	I.C.	ROHM	
IC702	BA15218N	I.C.	ROHM	
IC703	BA15218N	I.C.	ROHM	
IC704	BA15218N	I.C.	ROHM	
IC705	BA15218N	I.C.	ROHM	
IC706	BA15218N	I.C.	ROHM	
IC707	BA15218N	I.C.	ROHM	
IC708	BA15218N	I.C.	ROHM	
IC709	BA15218N	I.C.	ROHM	
IC710	NJM4200D	I.C.		
IC711	LC4966	I.C.	SANYO	
IC712	BA235	I.C.	ROHM	

DIODES				
ITEM	PART NUMBER	DESCRIPTION	AREA	
			MAKER	
D401	1SS133	SILICON	ROHM	
D402	1SS133	SILICON	ROHM	
D403	HZ6B1LTD	ZENER		
D404	HZ6B1LTD	ZENER		
D405	1SS133	SILICON	ROHM	
D406	1SS133	SILICON	ROHM	
D407	1SS133	SILICON	ROHM	
D408	1SS133	SILICON	ROHM	
D409	1SS81TD	SILICON		
D410	1SS81TD	SILICON		
D411	RD2.7EB2	ZENER	NEC	
D412	RD2.7EB2	ZENER	NEC	
D413	RD2.7EB2	ZENER	NEC	
D414	RD2.7EB2	ZENER	NEC	
D415	RD2.7EB2	ZENER	NEC	
D416	RD2.7EB2	ZENER	NEC	
D417	1SS133	SILICON	ROHM	
D418	1SS133	SILICON	ROHM	
D419	1SS291	SILICON	ROHM	
D420	1SS291	SILICON	ROHM	
D421	1SS81TD	SILICON		
D422	1SS81TD	SILICON		
D423	1SS81TD	SILICON		
D424	1SS81TD	SILICON		
D425	1SS133	SILICON	ROHM	
D426	1SS133	SILICON	ROHM	
D427	HZ6B1LTD	ZENER		
D428	HZ6B1LTD	ZENER		
D431	1SS81TD	SILICON		
D432	1SS81TD	SILICON		
D551	SLR-340C3F	L.E.D.	ROHM	
D552	ERA15-02L19	SILICON		
D553	ERA15-02L19	SILICON		
D701	1SS133	SILICON	ROHM	
D702	1SS133	SILICON	ROHM	
D703	1SS133	SILICON	ROHM	
D704	1SS133	SILICON	ROHM	
D705	1SS133	SILICON	ROHM	
D706	1SS133	SILICON	ROHM	
D707	1SS133	SILICON	ROHM	
D708	1SS133	SILICON	ROHM	
D709	1SS133	SILICON	ROHM	
D710	1SS133	SILICON	ROHM	
D711	1SS133	SILICON	ROHM	
D712	1SS133	SILICON	ROHM	
D713	1SS133	SILICON	ROHM	
D714	1SS133	SILICON	ROHM	
D717	1SS133	SILICON	ROHM	
D718	1SS133	SILICON	ROHM	
D719	1SS133	SILICON	ROHM	

△ : SAFETY PARTS

DIODES

ITEM	PART NUMBER	DESCRIPTION		AREA
		MAKER		
D720	1SS133	SILICON	ROHM	
D721	1SS133	SILICON	ROHM	
D722	1SS133	SILICON	ROHM	
D723	1SS133	SILICON	ROHM	
D724	1SS133	SILICON	ROHM	
D727	1SS133	SILICON	ROHM	
D728	1SS133	SILICON	ROHM	
D729	1SS133	SILICON	ROHM	
D730	1SS133	SILICON	ROHM	
D731	1SS133	SILICON	ROHM	
D732	1SS133	SILICON	ROHM	
D733	1SS133	SILICON	ROHM	
D734	SLR-34DC50F	L.E.D.	ROHM	
D735	SLR-34DC50F	L.E.D.	ROHM	
D736	MTZ15JC	ZENER	ROHM	
D737	MTZ15JC	ZENER	ROHM	
D739	1SS133	SILICON	ROHM	

CAPACITORS

ITEM	PART NUMBER	DESCRIPTION		AREA
C401	QCS21HJ-331	330PF	50V CERAMIC	G
C401	QFS31HJ-560	56PF	50V POLYSTYROL	B
C401	QFS31HJ-560	56PF	50V POLYSTYROL	C
C401	QFS31HJ-560	56PF	50V POLYSTYROL	DBS
C401	QFS31HJ-560	56PF	50V POLYSTYROL	F
C402	QCS21HJ-331	330PF	50V CERAMIC	B
C402	QFS31HJ-560	56PF	50V POLYSTYROL	G
C402	QFS31HJ-560	56PF	50V POLYSTYROL	C
C402	QFS31HJ-560	56PF	50V POLYSTYROL	DBS
C402	QFS31HJ-560	56PF	50V POLYSTYROL	E
C402	QFS31HJ-560	56PF	50V POLYSTYROL	F
C403	QFS31HJ-102	1000PF	50V POLYSTYROL	
C404	QFS31HJ-102	1000PF	50V POLYSTYROL	
C405	QFS82BJ-390	39PF	125V POLYSTYROL	
C406	QFS82BJ-390	39PF	125V POLYSTYROL	
C407	QFS82BJ-680	68PF	125V POLYSTYROL	
C408	QFS82BJ-680	68PF	125V POLYSTYROL	
C409	QFS31HJ-222	2200PF	50V POLYSTYROL	
C410	QFS31HJ-222	2200PF	50V POLYSTYROL	
C411	QFS31HJ-222	2200PF	50V POLYSTYROL	
C412	QFS31HJ-222	2200PF	50V POLYSTYROL	
C413	QFS81HJ-220	22PF	50V POLYSTYROL	
C414	QFS81HJ-220	22PF	50V POLYSTYROL	
C415	QFS31HJ-121	120PF	50V POLYSTYROL	
C416	QFS31HJ-121	120PF	50V POLYSTYROL	
C417	QFS82BJ-220	22PF	125V POLYSTYROL	
C418	QFS82BJ-220	22PF	125V POLYSTYROL	
C419	QFS82BJ-220	22PF	125V POLYSTYROL	
C420	QFS82BJ-220	22PF	125V POLYSTYROL	
C421	QFN81HJ-102	1000PF	50V MYLAR	
C422	QFN81HJ-102	1000PF	50V MYLAR	
C423	QFN81HJ-102	1000PF	50V MYLAR	
C424	QFN81HJ-102	1000PF	50V MYLAR	
C425	EEW6307-108	1000MF	ELECTRO	
C426	EEW6307-108	1000MF	ELECTRO	
C427	EEW3502-478	4700MF	ELECTRO	
C428	EEW3502-478	4700MF	ELECTRO	
C429	EFZ0091-103	0.01MF	630V M.MYLAR	
C430	QETB1HM-106	10MF	50V ELECTRO	
C431	QFN81HJ-102	1000PF	50V MYLAR	
C432	QETB1AM-476	47MF	10V ELECTRO	
C433	QETB1AM-476	47MF	10V ELECTRO	
C434	QETB1HM-474	0.47MF	50V ELECTRO	
C435	QFN81HJ-153	0.015MF	50V MYLAR	
C436	QETB1CM-226	22MF	16V ELECTRO	
C437	QETB1HM-474	0.47MF	50V ELECTRO	
C439	QETB1AM-107	100MF	10V ELECTRO	
C439	QETB1AM-107	100MF	10V ELECTRO	
C440	QETB1AM-107	100MF	10V ELECTRO	
C440	QETB1AM-107	100MF	10V ELECTRO	
C451	QCSB1HK-101	100PF	50V CERAMIC	G
C451	QCSB1HJ-680	68PF	50V CERAMIC	B
C451	QCSB1HJ-680	68PF	50V CERAMIC	C
C451	QCSB1HJ-680	68PF	50V CERAMIC	DBS
C451	QCSB1HJ-680	68PF	50V CERAMIC	
C452	QCSB1HJ-680	68PF	50V CERAMIC	B
C452	QCSB1HJ-680	68PF	50V CERAMIC	C

CAPACITORS

ITEM	PART NUMBER	DESCRIPTION		AREA
C452	QCSB1HJ-680	68PF	50V CERAMIC	DBS
C452	QCSB1HJ-680	68PF	50V CERAMIC	E
C452	QCSB1HJ-680	68PF	50V CERAMIC	F
C453	QCS21HJ-221	2200PF	50V CERAMIC	G
C454	QCS21HJ-221	2200PF	50V CERAMIC	G
C455	QCHB1EZ-223	0.022MF	25V CERAMIC	G
C456	QCHB1EZ-223	0.022MF	25V CERAMIC	G
C505	QCF21HP-223	0.022MF	50V CERAMIC	
C551	QFV81HJ-104	0.1MF	50V T.FILM	
C552	QFV81HJ-104	0.1MF	50V T.FILM	
C553	QETB1AM-476	47MF	10V ELECTRO	
C554	QCF21HP-223	0.022MF	50V CERAMIC	
C555	QETB1HM-105	1MF	50V ELECTRO	
C561	QEN51HM-225	2.2MF	50V NON POLE	
C701	QCS21HJ-220	22PF	50V CERAMIC	
C703	QETB1CM-476	47MF	16V ELECTRO	
C704	QETB1CM-476	47MF	16V ELECTRO	
C705	QETB1CM-107	100MF	16V ELECTRO	
C706	QFN81HJ-472	4700PF	50V MYLAR	
C707	QFN81HJ-472	4700PF	50V MYLAR	
C708	QFN81HJ-472	4700PF	50V MYLAR	
C709	QFN81HJ-472	4700PF	50V MYLAR	
C710	QETB1HM-225	2.2MF	50V ELECTRO	
C711	QETB1HM-106	10MF	50V ELECTRO	
C712	QFN81HJ-103	0.01MF	50V MYLAR	
C713	QETB1HM-227	220MF	50V ELECTRO	
C715	QETB1CM-107	100MF	16V ELECTRO	
C716	QETB1CM-107	100MF	16V ELECTRO	
C717	QCS21HJ-820	82PF	50V CERAMIC	
C719	QETB1CM-227	220MF	16V ELECTRO	

RESISTORS

ITEM	PART NUMBER	DESCRIPTION		AREA
R401	ERD141J-101SY	100	1/4W CARBON	B
R401	ERD141J-101SY	100	1/4W CARBON	C
R401	ERD141J-101SY	100	1/4W CARBON	DBS
R401	ERD141J-101SY	100	1/4W CARBON	E
R401	ERD141J-101SY	100	1/4W CARBON	F
R401	ERD141J-101SY	100	1/4W CARBON	G
R402	ERD141J-101SY	100	1/4W CARBON	B
R402	ERD141J-101SY	100	1/4W CARBON	C
R402	ERD141J-101SY	100	1/4W CARBON	DBS
R402	ERD141J-101SY	100	1/4W CARBON	E
R402	ERD141J-101SY	100	1/4W CARBON	F
R402	ERD141J-221SY	220	1/4W CARBON	G
R403	ERD141J-105SY	1M	1/4W CARBON	
R404	ERD141J-105SY	1M	1/4W CARBON	
R405	QVPE601-101	100	0.15W VARIABLE	
R406	QVPE601-101	100	0.15W VARIABLE	
R407	QRD167J-220	22	1/6W CARBON	
R408	QRD167J-220	22	1/6W CARBON	
R409	QRD167J-220	22	1/6W CARBON	
R410	QRD167J-220	22	1/6W CARBON	
R411	QRD167J-471	470	1/6W CARBON	
R412	QRD167J-471	470	1/6W CARBON	
R413	QRD14CJ-331S	330	1/4W UNF. CARBON	
R414	QRD14CJ-331S	330	1/4W UNF. CARBON	
R415	ERD141J-222SY	2.2K	1/4W CARBON	
R416	ERD141J-222SY	2.2K	1/4W CARBON	
R417	QRD14CJ-331S	330	1/4W UNF. CARBON	
R418	QRD14CJ-331S	330	1/4W UNF. CARBON	
R419	QRD14CJ-561S	560	1/4W UNF. CARBON	
R420	QRD14CJ-561S	560	1/4W UNF. CARBON	
R421	QRD14CJ-561S	560	1/4W UNF. CARBON	
R422	QRD14CJ-561S	560	1/4W UNF. CARBON	
R423	QRD14CJ-331S	330	1/4W UNF. CARBON	
R424	QRD14CJ-331S	330	1/4W UNF. CARBON	
R425	QRD14CJ-331S	330	1/4W UNF. CARBON	
R426	QRD14CJ-331S	330	1/4W UNF. CARBON	
R427	QRD14CJ-221S	220	1/4W UNF. CARBON	G
R428	QRD14CJ-221S	220	1/4W UNF. CARBON	G
R429	QRD14CJ-102S	1K	1/4W UNF. CARBON	
R430	QRD14CJ-102S	1K	1/4W UNF. CARBON	
R431	QRD167J-223	22K	1/6W CARBON	
R432	QRD167J-223	22K	1/6W CARBON	
R433	QRZ0077-680	68	1/4W FUSIBLE	
R434	QRZ0077-680	68	1/4W FUSIBLE	
R435	QRD167J-562	5.6K	1/6W CARBON	
R436	QRD167J-562	5.6K	1/6W CARBON	
R437	QRD167J-562	5.6K	1/6W CARBON	
R438	QRD167J-562	5.6K	1/6W CARBON	
R439	QRD167J-332	3.3K	1/6W CARBON	
R440	QRD167J-332	3.3K	1/6W CARBON	

△ : SAFETY PARTS

RESISTORS

ITEM	PART NUMBER	DESCRIPTION		AREA
R441	QRD14CJ-151S	150	1/4W UNF. CARBON	
R442	QRD14CJ-151S	150	1/4W UNF. CARBON	
R443	QRD14CJ-101S	100	1/4W UNF. CARBON	
R444	QRD14CJ-101S	100	1/4W UNF. CARBON	
R445	QRD167J-153	15K	1/6W CARBON	
R446	QRD167J-153	15K	1/6W CARBON	
R447	QRD167J-273	27K	1/6W CARBON	
R448	QRD167J-273	27K	1/6W CARBON	
R449	QRD14CJ-681S	680	1/4W UNF. CARBON	
R450	QRD14CJ-681S	680	1/4W UNF. CARBON	
R451	QRD167J-102	1K	1/6W CARBON	
R452	QRD167J-102	1K	1/6W CARBON	
R457	QVPE601-101	100	0.15W VARIABLE	
R458	QVPE601-101	100	0.15W VARIABLE	
R459	QRD167J-473	47K	1/6W CARBON	
R460	QRD167J-473	47K	1/6W CARBON	
R461	QVPE601-501	500	0.15W VARIABLE	
R462	QVPE601-501	500	0.15W VARIABLE	
R463	QRD167J-101	100	1/6W CARBON	
R464	QRD167J-101	100	1/6W CARBON	
R465	ERT-D2WFL351S	350	1/4W THERMISTOR	
R466	ERT-D2WFL351S	350	1/4W THERMISTOR	
R467	QRD167J-391	390	1/6W CARBON	
R468	QRD167J-391	390	1/6W CARBON	
R469	QRZ0077-271	270	1/4W FUSIBLE	
R470	QRZ0077-271	270	1/4W FUSIBLE	
R471	QRZ0077-271	270	1/4W FUSIBLE	
R472	QRZ0077-271	270	1/4W FUSIBLE	
R473	QRZ0077-470	47	1/4W FUSIBLE	
R474	QRZ0077-470	47	1/4W FUSIBLE	
R475	QRZ0077-470	47	1/4W FUSIBLE	
R476	QRZ0077-470	47	1/4W FUSIBLE	
R477	QRZ0063-4R7	4.7	1/2W FUSIBLE	
R478	QRZ0063-4R7	4.7	1/2W FUSIBLE	
R479	QRZ0063-4R7	4.7	1/2W FUSIBLE	
R480	QRZ0063-4R7	4.7	1/2W FUSIBLE	
R481	QRZ0063-4R7	4.7	1/2W FUSIBLE	
R482	QRZ0063-4R7	4.7	1/2W FUSIBLE	
R483	QRZ0063-4R7	4.7	1/2W FUSIBLE	
R484	QRZ0063-4R7	4.7	1/2W FUSIBLE	
R485	ERZ0001-R22	0.22	3W EMITTER	
R486	ERZ0001-R22	0.22	3W EMITTER	
R487	ERZ0001-R22	0.22	3W EMITTER	
R488	ERZ0001-R22	0.22	3W EMITTER	
R489	ERZ0001-R22	0.22	3W EMITTER	
R490	ERZ0001-R22	0.22	3W EMITTER	
R491	ERZ0001-R22	0.22	3W EMITTER	
R492	ERZ0001-R22	0.22	3W EMITTER	
R493	QRD167J-100	10	1/6W CARBON	
R494	QRD167J-100	10	1/6W CARBON	
R495	QRD167J-100	10	1/6W CARBON	
R496	QRD167J-100	10	1/6W CARBON	
R497	QRD167J-621	620	1/6W CARBON	
R498	QRD167J-621	620	1/6W CARBON	
R499	QRD167J-621	620	1/6W CARBON	
R500	QRD167J-621	620	1/6W CARBON	
R501	QRD167J-271	270	1/6W CARBON	
R502	QRD167J-271	270	1/6W CARBON	
R503	QRD167J-121	120	1/6W CARBON	
R504	QRD167J-121	120	1/6W CARBON	
R505	QRD167J-121	120	1/6W CARBON	
R506	QRD167J-121	120	1/6W CARBON	
R507	QRD167J-222	2.2K	1/6W CARBON	
R508	QRD167J-222	2.2K	1/6W CARBON	
R509	QRZ0077-102	1K	1/4W FUSIBLE	B
R509	QRZ0077-182	1.8K	1/4W FUSIBLE	C
R509	QRZ0077-182	1.8K	1/4W FUSIBLE	DBS
R509	QRZ0077-182	1.8K	1/4W FUSIBLE	E
R509	QRZ0077-182	1.8K	1/4W FUSIBLE	F
R509	QRZ0077-182	1.8K	1/4W FUSIBLE	G
R510	QRZ0077-			

RESISTORS

△	ITEM	PART NUMBER	DESCRIPTION			AREA
	R716	QRD167J-243	24K	1/6W	CARBON	
	R717	QRD167J-473	47K	1/6W	CARBON	
	R718	QRD167J-473	47K	1/6W	CARBON	
	R719	QRD167J-473	47K	1/6W	CARBON	
	R720	QRD167J-473	47K	1/6W	CARBON	
	R721	QRD167J-154	150K	1/6W	CARBON	
	R722	QRD167J-154	150K	1/6W	CARBON	
	R723	QRD167J-363	36K	1/6W	CARBON	
	R724	QRD167J-363	36K	1/6W	CARBON	
	R725	QRD167J-154	150K	1/6W	CARBON	
	R726	QRD167J-154	150K	1/6W	CARBON	
	R727	QRD167J-154	150K	1/6W	CARBON	
	R728	QRD167J-154	150K	1/6W	CARBON	
	R729	QRD167J-154	150K	1/6W	CARBON	
	R730	QRD167J-154	150K	1/6W	CARBON	
	R731	QRD167J-243	24K	1/6W	CARBON	
	R732	QRD167J-243	24K	1/6W	CARBON	
	R733	QRD167J-183	18K	1/6W	CARBON	
	R734	QRD167J-183	18K	1/6W	CARBON	
	R735	QRD167J-124	120K	1/6W	CARBON	
	R736	QRD167J-124	120K	1/6W	CARBON	
	R737	QRD167J-124	120K	1/6W	CARBON	
	R738	QRD167J-124	120K	1/6W	CARBON	
	R739	QRD167J-223	22K	1/6W	CARBON	
	R740	QRD167J-223	22K	1/6W	CARBON	
	R741	QRD167J-183	18K	1/6W	CARBON	
	R742	QRD167J-183	18K	1/6W	CARBON	
	R743	QRD167J-223	22K	1/6W	CARBON	
	R744	QRD167J-223	22K	1/6W	CARBON	
	R745	QRD167J-223	22K	1/6W	CARBON	
	R746	QRD167J-223	22K	1/6W	CARBON	
	R747	QRD167J-223	22K	1/6W	CARBON	
	R748	QRD167J-223	22K	1/6W	CARBON	
	R749	QRD167J-682	6.8K	1/6W	CARBON	
	R750	QRD167J-682	6.8K	1/6W	CARBON	
	R751	QRD167J-102	1K	1/6W	CARBON	
	R752	QRD167J-472	4.7K	1/6W	CARBON	
	R753	QRD167J-103	10K	1/6W	CARBON	
	R754	QRD167J-473	47K	1/6W	CARBON	
	R755	QRD167J-222	2.2K	1/6W	CARBON	
	R756	QRD167J-105	1M	1/6W	CARBON	
	R757	QRD167J-472	4.7K	1/6W	CARBON	
	R758	QRD167J-122	1.2K	1/6W	CARBON	
	R759	QRD167J-332	3.3K	1/6W	CARBON	
	R760	QRD167J-684	680K	1/6W	CARBON	
	R761	QRD167J-222	2.2K	1/6W	CARBON	
	R762	QRD167J-123	12K	1/6W	CARBON	
	R763	QRD167J-153	15K	1/6W	CARBON	
	R764	QRD167J-471	470	1/6W	CARBON	
	R765	QRD167J-824	820K	1/6W	CARBON	
	R766	QRD167J-102	1K	1/6W	CARBON	
	R767	QRD167J-102	1K	1/6W	CARBON	
	R768	QRD167J-104	100K	1/6W	CARBON	
	R769	QRD167J-104	100K	1/6W	CARBON	
	R770	QRD167J-104	100K	1/6W	CARBON	
	R771	QRD167J-104	100K	1/6W	CARBON	
	R772	QRD167J-104	100K	1/6W	CARBON	
	R773	QRD167J-104	100K	1/6W	CARBON	
	R774	QRD167J-104	100K	1/6W	CARBON	
	R775	QRD167J-104	100K	1/6W	CARBON	
	R776	QRD167J-104	100K	1/6W	CARBON	
	R777	QRD167J-103	10K	1/6W	CARBON	
	R778	QRD167J-103	10K	1/6W	CARBON	
	R779	QRD167J-103	10K	1/6W	CARBON	
	R780	QRD167J-103	10K	1/6W	CARBON	
	R781	QRD167J-475	4.7M	1/6W	CARBON	
	R782	QRD167J-475	4.7M	1/6W	CARBON	
	R783	QRD167J-475	4.7M	1/6W	CARBON	
	R784	QRD167J-475	4.7M	1/6W	CARBON	
	R785	QVPC603-102	1K	0.3W	VARIABLE	
	R786	QRD167J-154	150K	1/6W	CARBON	
	R787	QRD167J-154	150K	1/6W	CARBON	
	R788	QRD167J-133	13K	1/6W	CARBON	
	R789	QRD167J-105	1M	1/6W	CARBON	
	R790	QRD167J-183	18K	1/6W	CARBON	
	R791	QRD167J-273	27K	1/6W	CARBON	
	R792	QRD167J-302	3K	1/6W	CARBON	
	R793	QRD167J-103	10K	1/6W	CARBON	
	R794	QRD167J-103	10K	1/6W	CARBON	
△	R795	QRD125J-331	330	1/2W	UNF. CARBON	
△	R796	QRD125J-221	220	1/2W	UNF. CARBON	
	R797	QRD167J-182	1.8K	1/6W	CARBON	
	R798	QRD167J-182	1.8K	1/6W	CARBON	
	R799	QRD167J-105	1M	1/6W	CARBON	
△	R800	QRD14CJ-4R7S	4.7	1/4W	UNF. CARBON	
△	R801	QRD14CJ-4R7S	4.7	1/4W	UNF. CARBON	
	R802	QRD167J-474	470K	1/6W	CARBON	
	R803	QRD167J-474	470K	1/6W	CARBON	
	R804	QRD167J-474	470K	1/6W	CARBON	
	R805	QRD167J-474	470K	1/6W	CARBON	

RESISTORS

△	ITEM	PART NUMBER	DESCRIPTION			AREA
	R809	QRD167J-222	2.2K	1/6W	CARBON	
	R810	QRD167J-222	2.2K	1/6W	CARBON	
	R811	QRD167J-100	10	1/6W	CARBON	
	VR551	QVDB87M-EF5B	250K		VARIABLE	
	VR552	QVDB87A-E24B	20K		VARIABLE	
	VR553	QVDB91Z-E15B	100K		VARIABLE	

OTHERS

△	ITEM	PART NUMBER	DESCRIPTION			AREA
		BUSH-PUL	BUSHING			
		EWS015-139	SOCKET WIRE			
		EWT011-079	TERMINAL WIRE			G
		E03675-004	FUSE CLIP			B
		E11543-102	CIRCUIT BOARD			B
		E11543-102	CIRCUIT BOARD			C
		E11543-102	CIRCUIT BOARD			E
		E11543-102	CIRCUIT BOARD			F
		E11543-102	CIRCUIT BOARD			G
		E11543-102BS	CIRCUIT BOARD			DBS
		E304366-003	HEAT SINK			
		E304952-001	BRACKET			
		E304952-002	BRACKET			
		E305489-001	COVER			B
		E65508-002	TAB			B
		E70306-002	HEAT SINK			
		E72018-002	WIRE CLAMP			
		E73525-001	SCREW			
		E73525-001	SCREW			DBS
		E73658-002	VOLUME BRACKET			
		E73698-001	SPACER			
		E74265-001	BRACKET			
		E74495-001	BRACKET			
		E74870-001	SCREW			B
		E74870-001	SCREW			DBS
		GBSE3008CC	SCREW			
		GBSE3008CC	SCREW			
		SBSB3008CC	SCREW			B
		SBSB3008CC	SCREW			C
		SBSB3008CC	SCREW			E
		SBSB3008CC	SCREW			F
		SBSB3008CC	SCREW			G
		SBSE3008CC	SCREW			
		SBSE3008CC	SCREW			
		SBSE3008CC	SCREW			B
		SBSE3012CC	SCREW			
		SBST3006CC	SCREW			
	J551	EMV7122-003Z	CONNECTOR			
	J601	EMV7122-003Z	CONNECTOR			
	J907	EMV7112-010	CONNECTOR			
	P908	EMV5124-009	PLUG ASSY			
	P909	EMV5124-007	PLUG ASSY			
	FW401	EWR33B-35KST	FLAT WIRE			
	FW402	EWR36B-45KST	FLAT WIRE			
	FW403	EWR36B-16LST	FLAT WIRE			
	FW404	EWR34B-16LST	FLAT WIRE			
	FW552	EWR33B-16SST	FLAT WIRE			
	FW553	EWR15D-25LP	FLAT WIRE			
	FW554	EWR16D-25LP1	FLAT WIRE			
	FW701	EWR33B-40SST	FLAT WIRE			
	FW702	EWR33B-20SST	FLAT WIRE			
	JT501	EMV7122-003Z	CONNECTOR			
	JT502	EMV7122-003Z	CONNECTOR			
	RT401	E67764-503	WRAPPING TERMINAL			
	RT402	E67764-503	WRAPPING TERMINAL			
	RT403	E67764-503	WRAPPING TERMINAL			
	RY551	ESK5D24-219F	RELAY			
	TP401	QMV5005-005K	PLUG ASSY			

△ : SAFETY PARTS

■ ENP-004 □ Digital Front PC Board Ass'y

Note: ENP-004 □ Varies according to the areas employed. See note (1) when placing an order.

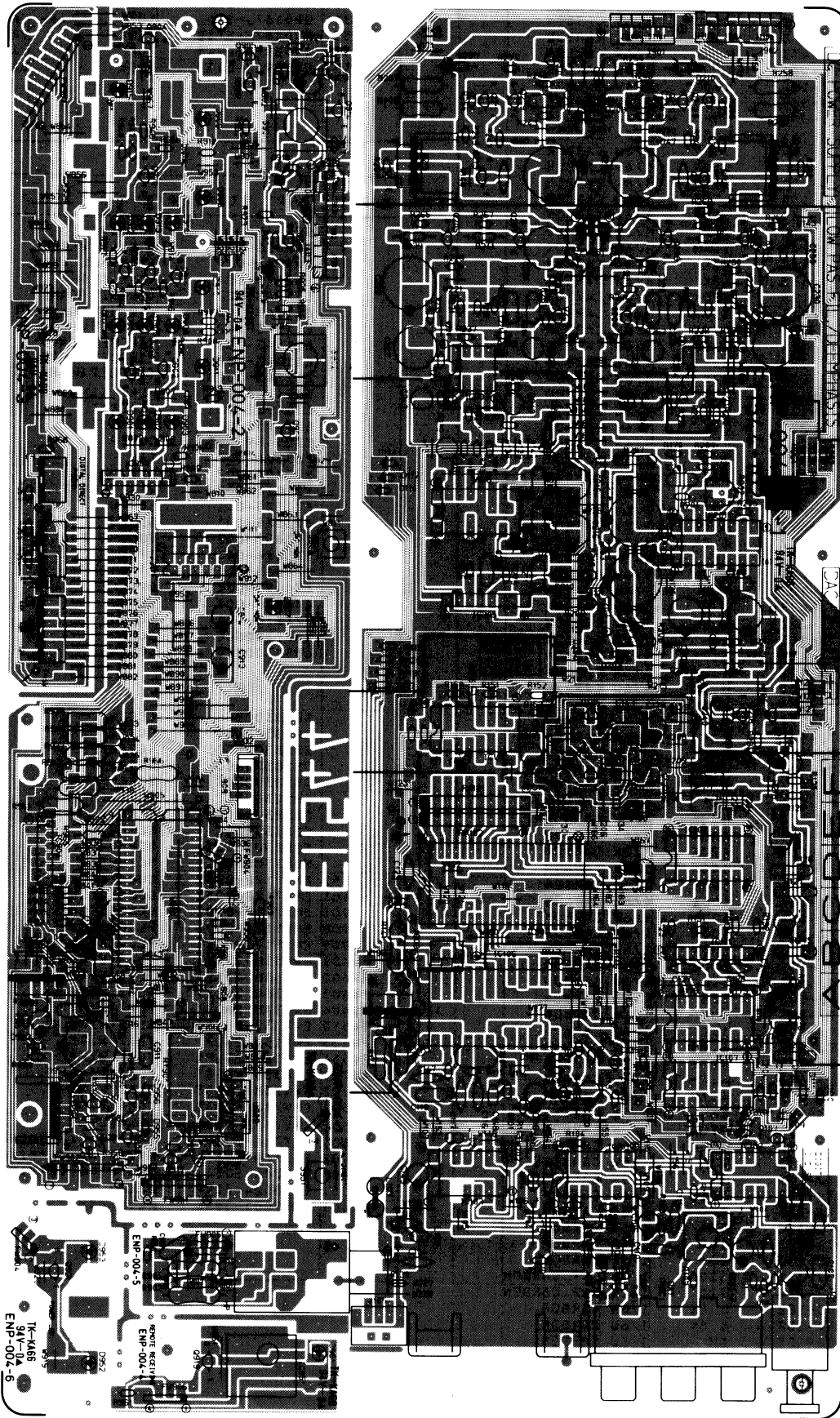

Note (1)

PC Board Ass'y	Designated Areas
ENP-004 [B]	U.S.A., Canada
ENP-004 [C]	U.S. Military Market, Australia, Continental Europe, U.K., Other Countries
ENP-004 [G]	West Germany

TRANSISTORS

ITEM	PART NUMBER	DESCRIPTION	AREA	
			MAKER	
Q101	DTC114YN	SILICON	ROHM	
Q102	DTC114YN	SILICON	ROHM	
Q103	DTC114YN	SILICON	ROHM	
Q105	2SA1015(Y)	SILICON		
Q106	2SA1015(Y)	SILICON		
Q107	2SC1815(Y)	SILICON		
Q203	2SC3068	SILICON	SANYO	
Q204	2SC3068	SILICON	SANYO	
Q205	2SC3068	SILICON	SANYO	
Q206	2SC3068	SILICON	SANYO	
Q207	2SC3068	SILICON	SANYO	
Q208	2SC3068	SILICON	SANYO	
Q209	2SC2240(GR,BL)	SILICON	TOSHIBA	
Q210	2SA970(GR,BL)	SILICON	TOSHIBA	
Q211	2SA965(O,Y)	SILICON	TOSHIBA	
Q212	2SC2235(O,Y)	SILICON	TOSHIBA	
Q213	2SA970(GR,BL)	SILICON	TOSHIBA	
Q214	2SC2240(GR,BL)	SILICON	TOSHIBA	
Q215	2SB1274(R,S)	SILICON	SANYO	
Q216	2SD1913(R,S)	SILICON	SANYO	
Q217	DTC114YN	SILICON	ROHM	
Q218	DTA114ES	SILICON	ROHM	
Q219	2SK246(Y)	F.E.T	TOSHIBA	
Q901	DTC114YN	SILICON	ROHM	
Q902	DTC114YN	SILICON	ROHM	
Q903	DTC114YN	SILICON	ROHM	
Q904	DTC114YN	SILICON	ROHM	
Q905	DTC114YN	SILICON	ROHM	
Q906	DTC114YN	SILICON	ROHM	
Q907	DTC114YN	SILICON	ROHM	
Q908	DTA114YN	SILICON	ROHM	
Q909	DTA114YN	SILICON	ROHM	
Q910	DTA114YN	SILICON	ROHM	
Q911	DTA114YN	SILICON	ROHM	
Q913	DTC144ES	SILICON	ROHM	
Q914	2SC1815(Y)	SILICON		
Q915	2SA1015(Y)	SILICON		
Q916	2SC1815(Y)	SILICON		
Q917	2SA733A(P,Q)	SILICON	NEC	
Q918	2SD2037(E,F)	SILICON	ROHM	
Q919	DTC114YN	SILICON	ROHM	
Q920	2SA1015(Y)	SILICON		

I. C. S

ITEM	PART NUMBER	DESCRIPTION	AREA	
			MAKER	
IC101	TC74HCU04P	I.C.		
IC102	TC74HC125P	I.C.	TOSHIBA	
IC103	TC74HC125P	I.C.	TOSHIBA	
IC105	NJM78M05A	I.C.		
IC106	YM3623B	I.C.		
IC107	TC74HC238P	I.C.	TOSHIBA	
IC108	VC4082-2	I.C.	SANYO	
IC109	LM33256N-15	I.C.	SANYO	
IC110	TC4053BP	I.C.	TOSHIBA	
IC111	BA15218N	I.C.	ROHM	
IC112	YM3404B	I.C.		
IC201	PCM56P	I.C.		
IC202	HD14053BP	I.C.	HITACHI	
IC203	NJM5532D	I.C.		
IC204	NJM5532D	I.C.		
IC205	M5238L	I.C.	MITSUBISHI	
IC901	UPD7507HCU-233	I.C.	NEC	
IC902	NJM78M06A	I.C.		
IC903	DT5C143E	I.C.	ROHM	
IC904	TA78	I.C.	ROHM	
IC951	GP1U501V	I.C.	SHARP	

DIODES

ITEM	PART NUMBER	DESCRIPTION	AREA	
			MAKER	
D102	1SS133	SILICON	ROHM	
D103	1SS133	SILICON	ROHM	
D104	1SS133	SILICON	ROHM	
D105	1SS133	SILICON	ROHM	
D106	1SS133	SILICON	ROHM	
D107	1SS133	SILICON	ROHM	
D108	1SS133	SILICON	ROHM	
D109	1SS133	SILICON	ROHM	
D110	1SS133	SILICON	ROHM	
D111	1SS133	SILICON	ROHM	
D112	1SS133	SILICON	ROHM	
D113	1SS133	SILICON	ROHM	
D114	1SS133	SILICON	ROHM	
D115	MTZ5.6JC	ZENER	ROHM	
D116	MTZ5.6JC	ZENER	ROHM	
D117	MTZ5.6JC	ZENER	ROHM	
D118	MTZ5.6JC	ZENER	ROHM	
D201	1SS133	SILICON	ROHM	
D202	1SS133	SILICON	ROHM	
D203	1SS133	SILICON	ROHM	
D204	1SS133	SILICON	ROHM	
D205	MTZ5.6JC	ZENER	ROHM	
D206	MTZ5.6JC	ZENER	ROHM	
D207	MTZ5.6JC	ZENER	ROHM	
D208	MTZ5.6JC	ZENER	ROHM	
D209	MTZ3.3JB	ZENER	ROHM	
D210	MTZ3.3JB	ZENER	ROHM	
D901	SLR-34DC3F	L.E.D.	ROHM	
D902	SLR-34DC3F	L.E.D.	ROHM	
D903	SLR-34DC3F	L.E.D.	ROHM	
D904	SLR-34DC3F	L.E.D.	ROHM	
D905	SLR-34DC3F	L.E.D.	ROHM	
D906	SLR-34DC3F	L.E.D.	ROHM	
D907	SLR-34VC3F	L.E.D.	ROHM	
D908	SLV-31YC3F	L.E.D.	ROHM	
D909	SLV-31YC3F	L.E.D.	ROHM	
D910	SLV-31DC3F	L.E.D.	ROHM	
D911	SLV-31DC3F	L.E.D.	ROHM	
D912	SLR-34YC3F	L.E.D.	ROHM	
D913	SLR-34YC3F	L.E.D.	ROHM	
D914	SLR-34YC3F	L.E.D.	ROHM	
D915	SLV-31YC3F	L.E.D.	ROHM	
D917	1SS133	SILICON	ROHM	
D918	1SS133	SILICON	ROHM	
D919	1SS133	SILICON	ROHM	
D921	MTZ5.6JC	ZENER	ROHM	
D922	MTZ22JC	ZENER	ROHM	
D951	SLR-34VC3F	L.E.D.	ROHM	
D952	SLV-31DC3F	L.E.D.	ROHM	
D953	SLV-31DC3F	L.E.D.	ROHM	
D954	1SS133	SILICON	ROHM	
D955	MTZ12JA	ZENER	ROHM	
D956	1SS133	SILICON	ROHM	
D957	1SS133	SILICON	ROHM	

CAPACITORS

ITEM	PART NUMBER	DESCRIPTION	AREA	
			MAKER	
C101	QETB1EM-107	100MF 25V	ELECTRO	
C103	QETB1EM-476	47MF 25V	ELECTRO	
C104	QETB1EM-476	47MF 25V	ELECTRO	
C106	QETB1EM-476	47MF 25V	ELECTRO	
C107	QCF21HP-103	0.01MF 50V	CERAMIC	
C109	QCF21HP-103	0.01MF 50V	CERAMIC	
C110	QCF21HP-103	0.01MF 50V	CERAMIC	
C111	QCF21HP-103	0.01MF 50V	CERAMIC	
C112	QCF21HP-103	0.01MF 50V	CERAMIC	
C113	QCF21HP-103	0.01MF 50V	CERAMIC	
C114	QCF21HP-103	0.01MF 50V	CERAMIC	
C115	QCF21HP-103	0.01MF 50V	CERAMIC	
C116	QCS21HJ-220	22PF 50V	CERAMIC	
C117	QCS21HJ-220	22PF 50V	CERAMIC	
C118	QETB1HM-105	1MF 50V	ELECTRO	
C119	QFN81HJ-822	8200PF 50V	MYLAR	
C120	QETB1HM-105	1MF 50V	ELECTRO	
C121	QCS21HJ-330	33PF 50V	CERAMIC	
C123	QCF21HP-103	0.01MF 50V	CERAMIC	C
C123	QCZ0205-155	1.5MF 25V	CERAMIC	B
C123	QCZ0205-155	1.5MF 25V	CERAMIC	D
C124	QETB1HM-225	2.2MF 50V	ELECTRO	
C125	QCF21HP-103	0.01MF 50V	CERAMIC	
C127	QCS21HJ-101	100PF 50V	CERAMIC	
C128	QCS21HJ-101	100PF 50V	CERAMIC	

Δ : SAFETY PARTS

CAPACITORS

△	ITEM	PART NUMBER	DESCRIPTION		AREA
	C129	QETB1EM-106	10MF	25V ELECTRO	
	C130	QETB1EM-106	10MF	25V ELECTRO	
	C131	QETB1EM-476	47MF	25V ELECTRO	
	C132	QETB1EM-476	47MF	25V ELECTRO	
	C135	QCF21HP-103	0.01MF	50V CERAMIC	
	C136	QFN81HJ-104	0.1MF	50V MYLAR	
	C137	QCS21HJ-821	820PF	50V CERAMIC	
	C138	QCS21HJ-821	820PF	50V CERAMIC	
	C139	QCS21HJ-470	47PF	50V CERAMIC	
	C140	QCS21HJ-470	47PF	50V CERAMIC	
	C141	QFN81HJ-123	0.012MF	50V MYLAR	
	C142	QFN81HJ-123	0.012MF	50V MYLAR	
	C143	QFN81HJ-822	8200PF	50V MYLAR	
	C144	QFN81HJ-822	8200PF	50V MYLAR	
	C147	QCS21HJ-471	470PF	50V CERAMIC	
	C148	QCB1HK-101	100PF	50V CERAMIC	
	C149	QETB1HM-475	4.7MF	50V ELECTRO	
	C151	QCS21HJ-221	220PF	50V CERAMIC	B
	C151	QCS21HJ-221	220PF	50V CERAMIC	C
	C151	QCS21HJ-471A	470PF	50V CERAMIC	D
	C152	QCZ0205-155	1.5MF	25V CERAMIC	B
	C152	QCZ0205-155	1.5MF	25V CERAMIC	D
	C153	QCZ0205-155	1.5MF	25V CERAMIC	B
	C153	QCZ0205-155	1.5MF	25V CERAMIC	D
	C154	QCS21HJ-471A	470PF	50V CERAMIC	D
	C155	QETB1HM-225	2.2MF	50V ELECTRO	
	C201	QFV81HJ-103	0.01MF	50V T.FILM	
	C202	QFV81HJ-223	0.022MF	50V T.FILM	
	C203	QFV81HJ-223	0.022MF	50V T.FILM	
	C204	QETB1CM-107	100MF	16V ELECTRO	
	C205	QETB1CM-107	100MF	16V ELECTRO	
	C207	EEZ41HM-107	100MF	50V ELECTRO	
	C208	EEZ41HM-107	100MF	50V ELECTRO	
	C209	QFV81HJ-223	0.022MF	50V T.FILM	
	C210	QFV81HJ-223	0.022MF	50V T.FILM	
	C211	QFV81HJ-223	0.022MF	50V T.FILM	
	C212	QFV81HJ-223	0.022MF	50V T.FILM	
	C213	QFV81HJ-223	0.022MF	50V T.FILM	
	C214	QFV81HJ-223	0.022MF	50V T.FILM	
	C215	QETB1AM-107	100MF	10V ELECTRO	
	C216	QETB1AM-107	100MF	10V ELECTRO	
	C219	QFP81HG-432	4300PF	50V POLY	
	C220	QFP81HG-432	4300PF	50V POLY	
	C221	QFP81HG-683	0.068MF	50V POLY	
	C222	QFP81HG-683	0.068MF	50V POLY	
	C225	QFS31HG-202	2000PF	50V POLYSTYROL	
	C226	QFS31HG-202	2000PF	50V POLYSTYROL	
	C227	QFS81HG-103	0.01MF	50V POLYSTYROL	
	C228	QFS81HG-103	0.01MF	50V POLYSTYROL	
	C229	EEZ41HM-107	100MF	50V ELECTRO	
	C230	EEZ41HM-107	100MF	50V ELECTRO	
	C231	QFS81HJ-682	6800PF	50V POLYSTYROL	
	C232	QFS81HJ-682	6800PF	50V POLYSTYROL	
	C233	QFP81HJ-102	1000PF	50V POLY	
	C234	QFP81HJ-102	1000PF	50V POLY	
	C235	EEZ5005-107	100MF	ELECTRO	
	C236	EEZ5005-107	100MF	ELECTRO	
	C237	QFP81HJ-103	0.01MF	50V POLY	
	C238	QFP81HJ-103	0.01MF	50V POLY	
	C239	QFV81HJ-103	0.01MF	50V T.FILM	
	C240	QFN81HJ-103	0.01MF	50V MYLAR	
	C241	QFS31HJ-560	56PF	50V POLYSTYROL	
	C242	QFS31HJ-560	56PF	50V POLYSTYROL	
	C243	QFS31HJ-681	680PF	50V POLYSTYROL	
	C244	QFS31HJ-681	680PF	50V POLYSTYROL	
	C245	QETB1CM-226	22MF	16V ELECTRO	
	C246	QETB1CM-226	22MF	16V ELECTRO	
	C247	QETB1HM-475	4.7MF	50V ELECTRO	
	C901	QEK61HM-225G	2.2MF	50V ELECTRO	
	C902	QEK61HM-225G	2.2MF	50V ELECTRO	
	C903	QEK61HM-475G	4.7MF	50V ELECTRO	
	C904	QETB0JM-228	2200MF	6.3V ELECTRO	
	C905	QFV81HJ-223	0.022MF	50V T.FILM	
	C911	QFN81HJ-103	0.01MF	50V MYLAR	
	C913	QETB1HM-106	10MF	50V ELECTRO	
	C914	QETB1HM-106	10MF	50V ELECTRO	
	C915	QETB1EM-106	10MF	25V ELECTRO	
	C916	QFN81HJ-223	0.022MF	50V MYLAR	
	C951	QFN81HJ-222	2200PF	50V MYLAR	D
	C952	QFN81HJ-222	2200PF	50V MYLAR	D

RESISTORS

△	ITEM	PART NUMBER	DESCRIPTION		AREA
	R101	QRD167J-750	75	1/6W CARBON	
	R102	QRD167J-750	75	1/6W CARBON	
	R103	QRD167J-750	75	1/6W CARBON	
	R104	QRD167J-103	10K	1/6W CARBON	
	R105	QRD167J-103	10K	1/6W CARBON	

RESISTORS

△	ITEM	PART NUMBER	DESCRIPTION		AREA
	R106	QRD167J-222	2.2K	1/6W CARBON	
	R107	QRD167J-222	2.2K	1/6W CARBON	
	R108	QRD167J-100	10	1/6W CARBON	
	R111	QRD167J-271	270	1/6W CARBON	
	R113	QRD167J-103	10K	1/6W CARBON	
	R114	QRD167J-103	10K	1/6W CARBON	
	R115	QRD167J-105	1M	1/6W CARBON	
	R116	QRD167J-223	22K	1/6W CARBON	
	R117	QRD167J-223	22K	1/6W CARBON	
	R118	QRD167J-223	22K	1/6W CARBON	
	R119	QRD167J-223	22K	1/6W CARBON	
	R120	QRD167J-223	22K	1/6W CARBON	
	R121	QRD167J-273	27K	1/6W CARBON	
	R122	QRD167J-273	27K	1/6W CARBON	
	R123	QRD167J-303	30K	1/6W CARBON	
	R124	QRD167J-303	30K	1/6W CARBON	
	R125	QRD167J-101	100	1/6W CARBON	
	R126	QRD167J-101	100	1/6W CARBON	
△	R127	QRD14CJ-220S	22	1/4W UNF. CARBON	
△	R128	QRD14CJ-220S	22	1/4W UNF. CARBON	
	R129	QRD167J-472	4.7K	1/6W CARBON	
	R130	QRD167J-102	1K	1/6W CARBON	
	R131	QRD167J-103	10K	1/6W CARBON	
	R132	QRD167J-103	10K	1/6W CARBON	
	R133	QRD167J-103	10K	1/6W CARBON	
	R134	QRD167J-103	10K	1/6W CARBON	
	R135	QRD167J-103	10K	1/6W CARBON	
	R136	QRD167J-103	10K	1/6W CARBON	
	R137	QRD167J-822	8.2K	1/6W CARBON	
	R138	QRD167J-822	8.2K	1/6W CARBON	
	R140	QRD167J-221	220	1/6W CARBON	B
	R140	QRD167J-221	220	1/6W CARBON	C
	R140	QRD167J-471	470	1/6W CARBON	D
△	R141	QRG022J-390A	39	2W O.M.FILM	B
△	R141	QRG022J-390A	39	2W O.M.FILM	D
△	R141	QRG026J-390AF	39	2W O.M.FILM	C
△	R142	QRD14CJ-100S	10	1/4W UNF. CARBON	
	R143	QRD167J-475	4.7M	1/6W CARBON	
	R145	QRD167J-101	100	1/6W CARBON	
	R146	QRD167J-471	470	1/6W CARBON	C
	R146	QRD167J-471	470	1/6W CARBON	D
	R147	QRD167J-101	100	1/6W CARBON	
	R148	QRD167J-101	100	1/6W CARBON	
	R149	QRD167J-101	100	1/6W CARBON	
	R150	QRD167J-101	100	1/6W CARBON	
	R151	QRD167J-101	100	1/6W CARBON	
	R152	QRD167J-101	100	1/6W CARBON	
	R153	QRD167J-101	100	1/6W CARBON	
	R170	QRD167J-564	560K	1/6W CARBON	
	R201	QRD167J-224	220K	1/6W CARBON	
	R202	QVZ3518-104	100K	0.1W VARIABLE	
	R203	QRD167J-474	470K	1/6W CARBON	
	R204	QRD167J-155	1.5M	1/6W CARBON	
	R205	QRD167J-471	470	1/6W CARBON	
	R206	QRD167J-101	100	1/6W CARBON	
△	R207	QRD14CJ-331S	330	1/4W UNF. CARBON	
△	R208	QRD14CJ-181S	180	1/4W UNF. CARBON	
△	R209	QRD14CJ-220S	22	1/4W UNF. CARBON	
△	R210	QRD14CJ-220S	22	1/4W UNF. CARBON	
	R213	QRD167J-182	1.8K	1/6W CARBON	
	R214	QRD167J-182	1.8K	1/6W CARBON	
	R215	QRD167J-102	1K	1/6W CARBON	
	R216	QRD167J-102	1K	1/6W CARBON	
	R217	QRD167J-182	1.8K	1/6W CARBON	
	R218	QRD167J-182	1.8K	1/6W CARBON	
	R219	QRD167J-155	1.5M	1/6W CARBON	
	R220	QRD167J-155	1.5M	1/6W CARBON	
△	R221	QRV144F-4700		1/4W M.FILM	
△	R222	QRV144F-4700		1/4W M.FILM	
	R225	QRD167J-201	200	1/6W CARBON	
	R226	QRD167J-201	200	1/6W CARBON	
	R227	QRD167J-130	13	1/6W CARBON	
	R228	QRD167J-130	13	1/6W CARBON	
△	R229	QRV144F-8200		1/4W M.FILM	
△	R230	QRV144F-8200		1/4W M.FILM	
	R231	QRD167J-180	18	1/6W CARBON	
	R232	QRD167J-180	18	1/6W CARBON	
	R233	QRD167J-820	82	1/6W CARBON	
	R234	QRD167J-820	82	1/6W CARBON	
△	R235	QRV144F-8200		1/4W M.FILM	
△	R236	QRV144F-8200		1/4W M.FILM	
	R237	QRD167J-101	100	1/6W CARBON	
	R238	QRD167J-101	100	1/6W CARBON	
	R239	ERD141J-151S	150	1/4W CARBON	
	R240	ERD141J-151S	150	1/4W CARBON	
	R241	ERD141J-151S	150	1/4W CARBON	
	R242	ERD141J-151S	150	1/4W CARBON	

△ : SAFETY PARTS

RESISTORS

△	ITEM	PART NUMBER	DESCRIPTION			AREA
	R243	QRD167J-822	8.2K	1/6W	CARBON	
	R244	QRD167J-822	8.2K	1/6W	CARBON	
	R245	QRD167J-562	5.6K	1/6W	CARBON	
	R246	QRD167J-562	5.6K	1/6W	CARBON	
	R247	QRD167J-272	2.7K	1/6W	CARBON	
	R248	QRD167J-272	2.7K	1/6W	CARBON	
	R249	QRD167J-101	100	1/6W	CARBON	
	R250	QRD167J-101	100	1/6W	CARBON	
	R251	QRD167J-821	820	1/6W	CARBON	
	R252	QRD167J-821	820	1/6W	CARBON	
	R253	QRD167J-562	5.6K	1/6W	CARBON	
	R254	QRD167J-562	5.6K	1/6W	CARBON	
	R255	QRD167J-222	2.2K	1/6W	CARBON	
	R256	QRD167J-222	2.2K	1/6W	CARBON	
△	R257	QRD125J-330	33	1/2W	UNF. CARBON	
△	R258	QRD125J-330	33	1/2W	UNF. CARBON	
△	R259	QRD125J-330	33	1/2W	UNF. CARBON	
△	R260	QRD125J-330	33	1/2W	UNF. CARBON	
	R261	QRD167J-105	1M	1/6W	CARBON	
	R262	QRD167J-105	1M	1/6W	CARBON	
	R263	QRD167J-182	1.8K	1/6W	CARBON	
	R264	QRD167J-182	1.8K	1/6W	CARBON	
	R265	QRD167J-103	10K	1/6W	CARBON	
	R266	QRD167J-103	10K	1/6W	CARBON	
	R267	QRD167J-103	10K	1/6W	CARBON	
	R268	QRD167J-103	10K	1/6W	CARBON	
	R269	QRD167J-104	100K	1/6W	CARBON	
	R270	QRD167J-105	1M	1/6W	CARBON	
	R271	QRD167J-104	100K	1/6W	CARBON	
	R273	QRD167J-750	75	1/6W	CARBON	
	R274	QRD167J-750	75	1/6W	CARBON	
△	R275	QRD14CJ-102S	1K	1/4W	UNF. CARBON	
△	R276	QRD14CJ-102S	1K	1/4W	UNF. CARBON	
	R277	QRD167J-821	820	1/6W	CARBON	
	R278	QRD167J-821	820	1/6W	CARBON	
	R279	QRD167J-101	100	1/6W	CARBON	
	R280	QRD167J-103	10K	1/6W	CARBON	
	R281	QRD167J-221	220	1/6W	CARBON	
△	R901	QRG022J-331A	330	2W	O.M. FILM	
△	R902	QRG022J-331A	330	2W	O.M. FILM	
	R904	QRD167J-222	2.2K	1/6W	CARBON	
	R905	QRD167J-470	47	1/6W	CARBON	
	R906	QRD167J-301	300	1/6W	CARBON	
	R907	QRD167J-301	300	1/6W	CARBON	
	R908	QRD167J-301	300	1/6W	CARBON	
	R909	QRD167J-223	22K	1/6W	CARBON	
	R910	QRD167J-301	300	1/6W	CARBON	
	R911	QRD167J-100	10	1/6W	CARBON	
	R912	QRD167J-910	91	1/6W	CARBON	
	R913	QRD167J-151	150	1/6W	CARBON	
	R914	QRD167J-181	180	1/6W	CARBON	
	R915	QRD167J-181	180	1/6W	CARBON	
	R916	QRD167J-181	180	1/6W	CARBON	
	R917	QRD167J-181	180	1/6W	CARBON	
	R919	QRD167J-123	12K	1/6W	CARBON	
	R920	QRD167J-123	12K	1/6W	CARBON	
	R921	QRD167J-473	47K	1/6W	CARBON	
	R922	QRD167J-223	22K	1/6W	CARBON	
	R923	QRD167J-123	12K	1/6W	CARBON	
	R924	QRD167J-472	4.7K	1/6W	CARBON	
	R925	QRD167J-393	39K	1/6W	CARBON	
	R926	QRD167J-103	10K	1/6W	CARBON	
	R927	QRD167J-151	150	1/6W	CARBON	
	R931	QRD167J-473	47K	1/6W	CARBON	
	R932	QRD167J-220	22	1/6W	CARBON	
	R933	QRD167J-473	47K	1/6W	CARBON	
	R934	QRD167J-473	47K	1/6W	CARBON	
	R935	QRD167J-473	47K	1/6W	CARBON	
	R936	QRD167J-473	47K	1/6W	CARBON	
	R937	QRD121J-121	120	1/2W	CARBON	
	R938	QRD121J-121	120	1/2W	CARBON	
	R939	QRD121J-121	120	1/2W	CARBON	
	R940	QRD121J-101	100	1/2W	CARBON	
	R941	QRD121J-101	100	1/2W	CARBON	
	R942	QRD121J-101	100	1/2W	CARBON	
	R946	QRD167J-8R2	8.2	1/6W	CARBON	
	R947	QRD167J-8R2	8.2	1/6W	CARBON	
	R948	QRD167J-8R2	8.2	1/6W	CARBON	
	R954	QRD167J-8R2	8.2	1/6W	CARBON	
△	R955	QRV144F-24R0	24	1/4W	M. FILM	
	R956	QRD167J-105	1M	1/6W	CARBON	
	R957	QRD167J-105	1M	1/6W	CARBON	
	R958	QRD167J-103	10K	1/6W	CARBON	
	R959	QRD167J-100	10	1/6W	CARBON	
	R960	QRD167J-224	220K	1/6W	CARBON	

RESISTORS

△	ITEM	PART NUMBER	DESCRIPTION			AREA
	R961	QRD167J-103	10K	1/6W	CARBON	
	R962	QRD167J-102	1K	1/6W	CARBON	
	R963	QRD167J-102	1K	1/6W	CARBON	
	R964	QRD167J-102	1K	1/6W	CARBON	
	R965	QRD148J-472S	4.7K	1/4W	CARBON	
	R966	QRD121J-472	4.7K	1/2W	CARBON	
	R968	QRD167J-103	10K	1/6W	CARBON	
△	R969	QRD14CJ-2R2S	2.2	1/4W	UNF. CARBON	B
△	R969	QRD14CJ-2R2S	2.2	1/4W	UNF. CARBON	C
	RA101	ERB08YJ-243	24K	8W	R.NETWORK	
	RA102	ERB08YJ-243	24K	8W	R.NETWORK	

OTHERS

△	ITEM	PART NUMBER	DESCRIPTION			AREA
		EWS016-104	SOCKET WIRE			
		EWT011-079	TERMINAL WIRE			D
		E11544-102	CIRCUIT BOARD			
		E304942-001	LED HOLDER			
		E304947-001	LED HOLDER			
		E33754-001	BAND			
		E65654-001	SPACER			C
		E70225-001	EARTH PLATE			
		E70306-006	HEAT SINK			
		E70306-006	HEAT SINK			
		SBSB3008CC	SCREW			
		SBSE3008CC	SCREW			
	J101	TORX172-VA	OPTICAL JACK			
	J103	EMN00YV-306A	3P PIN JACK			
	J105	QMS3533-001	MINI JACK			
	J951	QMS6312-022	HEADPHONE JACK			
	L101	EQL4004-560	INDUCTOR			
	L102	EQL4004-1R0	INDUCTOR			
	L103	ENZ8101-007	INDUCTOR			
	L104	ENZ8101-008	INDUCTOR			B
	P951	QMV5005-004K	PLUG ASSY			
	P952	QMV5005-005K	PLUG ASSY			
	P953	QMV5005-006K	PLUG ASSY			
	S951	ESP0001-007	TACT SWITCH			
	T101	ENZ3003-001	COIL			
	X101	ECX0018-000KS	RESONATOR			
	X901	ECX00004-194KM	RESONATOR			
	FW551	EWR23C-50LN	FLAT WIRE			
	FW901	EWR36B-13LST	FLAT WIRE			
	FW902	EWR37B-13LST	FLAT WIRE			
	FW903	EWR33B-30SST	FLAT WIRE			
	FW904	EWR33B-20SST	FLAT WIRE			
	FW905	EWR14A-16SS	FLAT WIRE			
	FW906	EWR34B-16SST	FLAT WIRE			
	FW907	EWR34B-13KST	FLAT WIRE			
	J 301	EMV7111-012	CONNECTOR			
	J 603	EMV7122-003Z	CONNECTOR			
	J 908	EMV7124-009	CONNECTOR			
	J 909	EMV7124-007	CONNECTOR			
	JT101	EMV7122-003Z	CONNECTOR			
	JT102	EMV7122-003Z	CONNECTOR			
	JT103	EMV7122-003Z	CONNECTOR			
	JT104	EMV7122-003Z	CONNECTOR			
	JT105	EMV7122-002Z	CONNECTOR			
	JT901	EMV7122-003Z	CONNECTOR			
	JT902	EMV7122-003Z	CONNECTOR			
	JT903	EMV7122-002Z	CONNECTOR			
	JT904	EMV7122-002Z	CONNECTOR			
	JT905	EMV7122-002Z	CONNECTOR			
	JT906	EMV7122-003Z	CONNECTOR			
	RY901	ESK7024-211	RELAY			
	S 901	ESP0001-017	TACT SWITCH			
	S 902	ESP0001-017	TACT SWITCH			
	S 903	ESP0001-011	TACT SWITCH			

△ : SAFETY PARTS

■ ENE-041 □ Analog Input/Output PC Board Ass'y

Note: ENE-041 □ Varies according to the areas employed. See note (1) when placing an order.

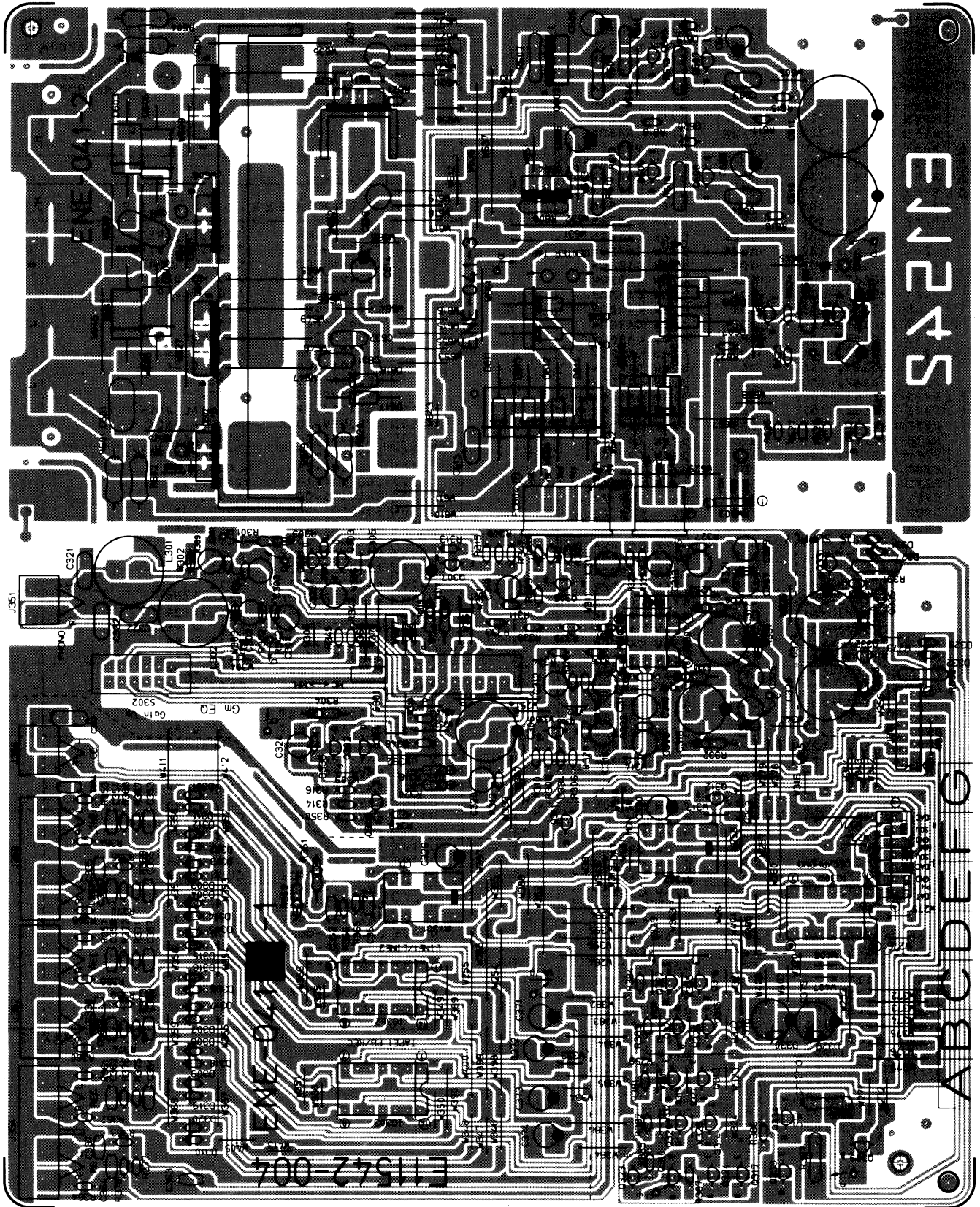

Note (1)

PC Board Ass'y	
ENE-041 B	U.S.A., Canada
ENE-041 C	U.S. Military Market, Australia Continental Europe, U.K., Other Countries
ENE-041 D	West Germany

TRANSISTORS

ITEM	PART NUMBER	DESCRIPTION		AREA
		MAKER		
Q301	2SK170(GR,BL)	F.E.T	TOSHIBA	
Q302	2SK170(GR,BL)	F.E.T	TOSHIBA	
Q303	2SK170(GR,BL)	F.E.T	TOSHIBA	
Q304	2SK170(GR,BL)	F.E.T	TOSHIBA	
Q305	2SA970(GR,BL)	SILICON	TOSHIBA	
Q306	2SA970(GR,BL)	SILICON	TOSHIBA	
Q307	2SC2240(GR,BL)	SILICON	TOSHIBA	
Q308	2SC2240(GR,BL)	SILICON	TOSHIBA	
Q309	DTC144ES	SILICON	ROHM	
Q310	DTA144ES	SILICON	ROHM	
Q311	DTC114YN	SILICON	ROHM	
Q312	DTC114YN	SILICON	ROHM	
Q313	DTC114YN	SILICON	ROHM	
Q314	DTC114YN	SILICON	ROHM	
Q315	DTC114YN	SILICON	ROHM	
Q316	DTC114YN	SILICON	ROHM	
Q317	DTC114YN	SILICON	ROHM	
Q319	DTA114EN	SILICON	ROHM	
Q320	DTA114EN	SILICON	ROHM	
Q321	DTA114EN	SILICON	ROHM	
Q322	DTA114EN	SILICON	ROHM	
Q323	DTA114EN	SILICON	ROHM	
Q324	DTA114EN	SILICON	ROHM	
Q331	2SC2235(O,Y)	SILICON	TOSHIBA	
Q332	2SA965(O,Y)	SILICON	TOSHIBA	
Q333	2SC2235(O,Y)	SILICON	TOSHIBA	
Q334	2SA965(O,Y)	SILICON	TOSHIBA	
Q335	2SK246(Y)	F.E.T	TOSHIBA	
Q601	2SD1842(P,Q)	SILICON	SANYO	
Q602	2SB1232(P,Q)	SILICON	SANYO	
Q603	2SB941A(P,Q)	SILICON	MATSUSHITA	
Q604	2SD1265A(P,Q)	SILICON	MATSUSHITA	
Q605	2SC1815(GR,BL)	SILICON	TOSHIBA	
Q606	2SA1015(Y,GR)	SILICON	TOSHIBA	
Q607	2SC1815(GR,BL)	SILICON	TOSHIBA	
Q608	2SA1015(Y,GR)	SILICON	TOSHIBA	
Q609	2SC1815(GR,BL)	SILICON	TOSHIBA	
Q610	2SD1302(S,T)	SILICON	MATSUSHITA	
Q611	2SB507V(D,E)	SILICON	SANYO	
Q612	2SC1815(Y)	SILICON		B

I. C. S

ITEM	PART NUMBER	DESCRIPTION		AREA
		MAKER		
IC301	NJM4560D-X	I.C.		
IC302	LC4966	I.C.	SANYO	
IC303	LC4966	I.C.	SANYO	
IC304	LC4966	I.C.	SANYO	

DIODES

ITEM	PART NUMBER	DESCRIPTION		AREA
		MAKER		
D301	1SS291	SILICON	ROHM	
D302	1SS291	SILICON	ROHM	
D303	1SS291	SILICON	ROHM	
D304	1SS291	SILICON	ROHM	
D305	1SS291	SILICON	ROHM	
D306	1SS291	SILICON	ROHM	
D307	1SS291	SILICON	ROHM	
D308	1SS291	SILICON	ROHM	
D309	1SS291	SILICON	ROHM	
D310	1SS291	SILICON	ROHM	
D311	1SS291	SILICON	ROHM	
D312	1SS291	SILICON	ROHM	
D313	1SS291	SILICON	ROHM	
D314	1SS291	SILICON	ROHM	
D315	1SS291	SILICON	ROHM	

DIODES

ITEM	PART NUMBER	DESCRIPTION			AREA
		MAKER			
D316	1SS291	SILICON	ROHM		
D317	1SS291	SILICON	ROHM		
D318	1SS291	SILICON	ROHM		
D319	1SS291	SILICON	ROHM		
D320	1SS291	SILICON	ROHM		
D325	MTZ15JC	ZENER	ROHM		
D326	MTZ15JC	ZENER	ROHM		
D327	1SS133	SILICON	ROHM		
D328	1SS133	SILICON	ROHM		
D329	MTZ15JC	ZENER	ROHM		
D330	MTZ15JC	ZENER	ROHM		
D331	1SS133	SILICON	ROHM		
D332	1SS133	SILICON	ROHM		
D333	1SS291	SILICON	ROHM		
D334	1SS291	SILICON	ROHM		
D335	1SS291	SILICON	ROHM		
D336	1SS291	SILICON	ROHM		
D601	FMM-22R	SI.DIODE			
D602	FMM-22S	SI.DIODE			
D603	30DF2SFC	SILICON	NIHONINTER		
D604	30DF2SFC	SILICON	NIHONINTER		
D605	30DF2SFC	SILICON	NIHONINTER		
D606	30DF2SFC	SILICON	NIHONINTER		
D607	20E2FA-5	SI.DIODE	NIHONINTER		
D608	20E2FA-5	SI.DIODE	NIHONINTER		
D609	20E2FA-5	SI.DIODE	NIHONINTER		
D610	20E2FA-5	SI.DIODE	NIHONINTER		
D611	20E2FA-5	SI.DIODE	NIHONINTER		
D612	20E2FA-5	SI.DIODE	NIHONINTER		
D613	20E2FA-5	SI.DIODE	NIHONINTER		
D614	20E2FA-5	SI.DIODE	NIHONINTER		
D615	10E2FD-1	ZENER	NIHONINTER		
D616	10E2FD-1	ZENER	NIHONINTER		
D617	10E2FD-1	ZENER	NIHONINTER		
D618	10E2FD-1	ZENER	NIHONINTER		
D619	1SS133	SILICON	ROHM		
D620	1SS133	SILICON	ROHM		
D621	MTZ15JC	ZENER	ROHM		

CAPACITORS

ITEM	PART NUMBER	DESCRIPTION			AREA
		MAKER			
C301	QFS31HJ-101	100PF	50V	POLYS TYROL	B
C301	QFS31HJ-101	100PF	50V	POLYS TYROL	C
C301	QFS31HJ-331	330PF	50V	POLYS TYROL	D
C302	QFS31HJ-101	100PF	50V	POLYS TYROL	B
C302	QFS31HJ-101	100PF	50V	POLYS TYROL	C
C302	QFS31HJ-331	330PF	50V	POLYS TYROL	D
C303	QFS31HJ-102	1000PF	50V	POLYS TYROL	
C304	QFS31HJ-102	1000PF	50V	POLYS TYROL	
C305	QETB0JM-228	2200MF	6.3V	ELECT RO	
C306	QETB0JM-228	2200MF	6.3V	ELECT RO	
C307	QFS31HJ-470	47PF	50V	POLYS TYROL	
C308	QFS31HJ-470	47PF	50V	POLYS TYROL	
C309	QFS31HJ-221	220PF	50V	POLYS TYROL	
C310	QFS31HJ-221	220PF	50V	POLYS TYROL	
C311	QFS81HG-682	6800PF	50V	POLYS TYROL	
C312	QFS81HG-682	6800PF	50V	POLYS TYROL	
C313	QFS81HG-103	0.01MF	50V	POLYS TYROL	
C314	QFS81HG-103	0.01MF	50V	POLYS TYROL	
C315	QFS31HG-472	4700PF	50V	POLYS TYROL	
C316	QFS31HG-472	4700PF	50V	POLYS TYROL	
C317	EEZ1005-106Z	10MF	100V	ELECT RO	
C318	EEZ1005-106Z	10MF	100V	ELECT RO	
C319	QFS31HJ-562	5600PF	50V	POLYS TYROL	
C320	QFS31HJ-562	5600PF	50V	POLYS TYROL	
C321	QFS31HJ-331	330PF	50V	POLYS TYROL	D
C322	QFS31HJ-331	330PF	50V	POLYS TYROL	D
C323	QFS31HJ-680	68PF	50V	POLYS TYROL	
C324	QFS31HJ-680	68PF	50V	POLYS TYROL	
C325	QFS31HJ-222	2200PF	50V	POLYS TYROL	D
C326	QFS31HJ-222	2200PF	50V	POLYS TYROL	D
C327	EEZ5003-107Z	100MF		ELECT RO	
C328	EEZ5003-107Z	100MF		ELECT RO	
C329	QETB1HM-105	1MF	50V	ELECT RO	
C330	QETB1HM-105	1MF	50V	ELECT RO	
C332	QCVB1CM-103	0.01MF	16V	CERAM IC	
C333	QCVB1CM-103	0.01MF	16V	CERAM IC	
C334	QCVB1CM-103	0.01MF	16V	CERAM IC	D
C334	QCVB1CM-103	0.01MF	16V	CERAM IC	B
C335	QCVB1CM-103	0.01MF	16V	CERAM IC	D
C335	QCVB1CM-103	0.01MF	16V	CERAM IC	B
C336	QCVB1CM-103	0.01MF	16V	CERAM IC	D
C336	QCVB1CM-103	0.01MF	16V	CERAM IC	B
C337	QCVB1CM-103	0.01MF	16V	CERAM IC	B
C337	QCVB1CM-103	0.01MF	16V	CERAM IC	B

Δ : SAFETY PARTS

CAPACITORS

△	ITEM	PART NUMBER	DESCRIPTION			AREA
	C351	QCBB1HK-221	220PF	50V	CERAMIC	D
	C352	QCBB1HK-221	220PF	50V	CERAMIC	D
	C353	QCBB1HK-221	220PF	50V	CERAMIC	D
	C354	QCBB1HK-221	220PF	50V	CERAMIC	D
	C355	QCBB1HK-221	220PF	50V	CERAMIC	D
	C356	QCBB1HK-221	220PF	50V	CERAMIC	D
	C357	QCBB1HK-221	220PF	50V	CERAMIC	D
	C358	QCBB1HK-221	220PF	50V	CERAMIC	D
	C359	QCBB1HK-221	220PF	50V	CERAMIC	D
	C360	QCBB1HK-221	220PF	50V	CERAMIC	D
	C361	QCBB1HK-221	220PF	50V	CERAMIC	D
	C362	QCBB1HK-221	220PF	50V	CERAMIC	D
	C363	QCBB1HK-221	220PF	50V	CERAMIC	D
	C364	QCBB1HK-221	220PF	50V	CERAMIC	D
	C375	QETB1EM-227	220MF	25V	ELECTRO	
	C376	QETB1EM-227	220MF	25V	ELECTRO	
	C601	EFZ0091-103	0.01MF	630V	M.MYLAR	B
	C602	EFZ0091-103	0.01MF	630V	M.MYLAR	C
	C602	EFZ0091-103	0.01MF	630V	M.MYLAR	C
	C602	EFZ0091-223	0.022MF	630V	M.MYLAR	D
	C607	QETB1HM-106	10MF	50V	ELECTRO	
	C608	QETB1HM-106	10MF	50V	ELECTRO	
	C609	QFN81HJ-473	0.047MF	50V	MYLAR	
	C610	QETB1EM-228	2200MF	25V	ELECTRO	
	C611	QETB1EM-228	2200MF	25V	ELECTRO	
	C614	EEZ3501-227M	220MF	35V	ELECTRO	D
	C614	QETB1HM-225	2.2MF	50V	ELECTRO	B
	C614	EEZ3501-227M	220MF	35V	ELECTRO	C
	C615	QFV81HJ-104	0.1MF	50V	T.FILM	
	C617	QENS1HM-475	4.7MF	50V	NON POLE	
	C618	QENS1HM-475	4.7MF	50V	NON POLE	
	C620	QETB1EM-476	47MF	25V	ELECTRO	
	C631	QFV81HJ-224	0.22MF	50V	T.FILM	D
	C632	QFV81HJ-224	0.22MF	50V	T.FILM	D

RESISTORS

△	ITEM	PART NUMBER	DESCRIPTION			AREA
	R301	QRD167J-473	47K	1/6W	CARBON	
	R302	QRD167J-473	47K	1/6W	CARBON	
	R303	ERD141J-5R6S	5.6	1/4W	CARBON	
	R304	ERD141J-5R6S	5.6	1/4W	CARBON	
	R305	QRD167J-222	2.2K	1/6W	CARBON	
	R306	QRD167J-222	2.2K	1/6W	CARBON	
	R307	QRD167J-242	2.4K	1/6W	CARBON	
	R308	QRD167J-242	2.4K	1/6W	CARBON	
	R309	QRD167J-272	2.7K	1/6W	CARBON	
	R310	QRD167J-272	2.7K	1/6W	CARBON	
	R311	QRD167J-470	47	1/6W	CARBON	
	R312	QRD167J-470	47	1/6W	CARBON	
	R313	QRD167J-471	470	1/6W	CARBON	
	R314	QRD167J-471	470	1/6W	CARBON	
	R315	QRD167J-102	1K	1/6W	CARBON	
	R316	QRD167J-102	1K	1/6W	CARBON	
	R317	ERD141J-220S	22	1/4W	CARBON	
	R318	ERD141J-220S	22	1/4W	CARBON	
	R319	ERD141J-271S	270	1/4W	CARBON	
	R320	ERD141J-271S	270	1/4W	CARBON	
	R321	QRD167J-125	1.2M	1/6W	CARBON	
	R322	QRD167J-125	1.2M	1/6W	CARBON	
△	R323	QRV144F-1002	10K	1/4W	M.FILM	
△	R324	QRV144F-1002	10K	1/4W	M.FILM	
△	R325	QRV144F-1803	180K	1/4W	M.FILM	
△	R326	QRV144F-1803	180K	1/4W	M.FILM	
△	R327	QRV144F-1602	16K	1/4W	M.FILM	
△	R328	QRV144F-1602	16K	1/4W	M.FILM	
	R329	ERD141J-101S	100	1/4W	CARBON	
	R330	ERD141J-101S	100	1/4W	CARBON	
	R331	QRD167J-104	100K	1/6W	CARBON	
	R332	QRD167J-104	100K	1/6W	CARBON	
	R333	QRD167J-475	4.7M	1/6W	CARBON	
	R334	QRD167J-475	4.7M	1/6W	CARBON	
	R335	QRD167J-475	4.7M	1/6W	CARBON	
	R336	QRD167J-475	4.7M	1/6W	CARBON	
	R337	QRD167J-155	1.5M	1/6W	CARBON	
	R338	QRD167J-155	1.5M	1/6W	CARBON	
	R339	QRD167J-125	1.2M	1/6W	CARBON	
	R340	QRD167J-125	1.2M	1/6W	CARBON	
	R341	QRD167J-471	470	1/6W	CARBON	
	R342	QRD167J-471	470	1/6W	CARBON	
	R343	QRD167J-200	20	1/6W	CARBON	
	R344	QRD167J-200	20	1/6W	CARBON	
	R345	QRD167J-271	270	1/6W	CARBON	

RESISTORS

△	ITEM	PART NUMBER	DESCRIPTION			AREA
	R346	QRD167J-271	270	1/6W	CARBON	
	R347	QRD167J-273	27K	1/6W	CARBON	
	R348	QRD167J-273	27K	1/6W	CARBON	
	R349	QRD167J-472	4.7K	1/6W	CARBON	
	R350	QRD167J-472	4.7K	1/6W	CARBON	
	R351	QRD167J-221	220	1/6W	CARBON	
	R352	QRD167J-221	220	1/6W	CARBON	
	R353	QRD167J-221	220	1/6W	CARBON	
	R354	QRD167J-221	220	1/6W	CARBON	
	R355	QRD167J-221	220	1/6W	CARBON	
	R356	QRD167J-221	220	1/6W	CARBON	
	R357	QRD167J-221	220	1/6W	CARBON	
	R358	QRD167J-221	220	1/6W	CARBON	
	R359	QRD167J-221	220	1/6W	CARBON	
	R360	QRD167J-221	220	1/6W	CARBON	
	R361	QRD167J-221	220	1/6W	CARBON	
	R362	QRD167J-221	220	1/6W	CARBON	
	R363	QRD167J-221	220	1/6W	CARBON	
	R364	QRD167J-221	220	1/6W	CARBON	
	R365	QRD167J-474	470K	1/6W	CARBON	
	R366	QRD167J-474	470K	1/6W	CARBON	
	R367	QRD167J-474	470K	1/6W	CARBON	
	R368	QRD167J-474	470K	1/6W	CARBON	
	R369	QRD167J-474	470K	1/6W	CARBON	
	R370	QRD167J-474	470K	1/6W	CARBON	
	R371	QRD167J-105	1M	1/6W	CARBON	
	R372	QRD167J-105	1M	1/6W	CARBON	
	R373	QRD167J-474	470K	1/6W	CARBON	
	R374	QRD167J-474	470K	1/6W	CARBON	
	R375	QRD167J-105	1M	1/6W	CARBON	
	R376	QRD167J-105	1M	1/6W	CARBON	
	R377	QRD167J-474	470K	1/6W	CARBON	
	R378	QRD167J-474	470K	1/6W	CARBON	
	R381	QRD167J-473	47K	1/6W	CARBON	
	R382	QRD167J-473	47K	1/6W	CARBON	
	R383	QRD167J-473	47K	1/6W	CARBON	
	R384	QRD167J-473	47K	1/6W	CARBON	
	R385	QRD167J-473	47K	1/6W	CARBON	
	R386	QRD167J-473	47K	1/6W	CARBON	
	R387	QRD167J-474	470K	1/6W	CARBON	
	R389	QRD167J-222	2.2K	1/6W	CARBON	D
	R390	QRD167J-222	2.2K	1/6W	CARBON	D
△	R391	QRD14CJ-220S	22	1/4W	UNF. CARBON	
△	R392	QRD14CJ-220S	22	1/4W	UNF. CARBON	
△	R393	QRD167J-103	10K	1/6W	CARBON	
△	R397	QRD14CJ-470S	47	1/4W	UNF. CARBON	
△	R398	QRD14CJ-470S	47	1/4W	UNF. CARBON	
△	R601	QRX012J-1R0AM	1	1W	M.FILM	
△	R602	QRX012J-1R0AM	1	1W	M.FILM	
△	R603	QRX012J-R47AF	0.47	1W	M.FILM	B
△	R603	QRX012J-R47AM	0.47	1W	M.FILM	C
△	R603	QRX012J-R47AM	0.47	1W	M.FILM	C
△	R604	QRX012J-R47AF	0.47	1W	M.FILM	C
△	R604	QRX012J-R47AM	0.47	1W	M.FILM	C
△	R607	QRD14CJ-820S	82	1/4W	UNF. CARBON	
△	R608	QRD14CJ-820S	82	1/4W	UNF. CARBON	
△	R609	QRD14CJ-391S	390	1/4W	UNF. CARBON	
△	R610	QRD14CJ-561S	560	1/4W	UNF. CARBON	
△	R611	QRD14CJ-151S	150	1/4W	UNF. CARBON	
△	R612	QRD14CJ-151S	150	1/4W	UNF. CARBON	
△	R613	QRD14CJ-391S	390	1/4W	UNF. CARBON	
△	R614	QRD14CJ-361S	360	1/4W	UNF. CARBON	
△	R615	QRD167J-183	18K	1/6W	CARBON	
△	R616	QRD167J-183	18K	1/6W	CARBON	
	R617	QRD167J-103	10K	1/6W	CARBON	
	R618	QRD167J-103	10K	1/6W	CARBON	
△	R619	QRX012J-R56AM	0.56	1W	M.FILM	B
△	R619	QRX022J-R22AM	0.22	2W	M.FILM	B
△	R619	QRX022J-R22AM	0.22	2W	M.FILM	B
△	R620	QRX012J-R56AM	0.56	1W	M.FILM	B
△	R620	QRX022J-R22AM	0.22	2W	M.FILM	B
△	R620	QRX022J-R22AM	0.22	2W	M.FILM	B
△	R621	QRD167J-102	1K	1/6W	CARBON	
	R622	QRD167J-272	2.7K	1/6W	CARBON	
	R623	QRD167J-103	10K	1/6W	CARBON	
	R624	QRD167J-473	47K	1/6W	CARBON	
	R625	QRD167J-222	2.2K	1/6W	CARBON	
	R626	QRD167J-2R2	2.2	1/6W	CARBON	
	R627	QRD167J-2R2	2.2	1/6W	CARBON	
	R628	QRD167J-110	11	1/6W	CARBON	

△ : SAFETY PARTS

OTHERS

△	ITEM	PART NUMBER	DESCRIPTION	AREA
		ENZ2006-001	SHIELD CASE	D
		E03532-001	SHIELD CASE	D
		E11542-102	CIRCUIT BOARD	
		E305013-001	HEAT SINK	
		E305014-003	BRACKET	
		E305014-004	BRACKET	
		E33754-001	BAND	
		E70306-002	HEAT SINK	
		E74943-002	SUB HEAT SINK	C
		E74943-002	SUB HEAT SINK	D
		G8SB3008CC	SCREW	
		SBSB3008CC	SCREW	
		SBSB3008CC	SCREW	
		SBSB3012CC	SCREW	
		SBSB3012CC	SCREW	
	J301	EMV7111-012	CONNECTOR	
	J351	EMN00TV-210A	2P PIN JACK	
	J352	EMN00TV-408A	4P PIN JACK	
	J353	EMN00TV-408A	4P PIN JACK	
	J354	EMN00TV-408A	4P PIN JACK	
	J355	EMN00TV-211A	2P PIN JACK	

OTHERS

△	ITEM	PART NUMBER	DESCRIPTION	AREA
	L301	EGL0111-391	INDUCTOR	D
	L302	EGL0111-391	INDUCTOR	D
	L303	ENZ8101-008	INDUCTOR	D
	S301	QST9101-E10	PUSH SWITCH	
	S302	QST9101-E04	PUSH SWITCH	
	FC604	EMV7112-006R	CONNECTOR	
	FC605	EMV7112-003R	CONNECTOR	C
	FC605	EMV7112-003R	CONNECTOR	D
	FC605	EMV7112-004R	CONNECTOR	B
	FW603	EWR33B-25LST	FLAT WIRE	
	JT301	EMV7122-003Z	CONNECTOR	
	JT302	EMV7122-002Z	CONNECTOR	
	JT303	EMV7122-002Z	CONNECTOR	
	RY301	ESK5D24-219F	RELAY	
	RY302	ESK5D24-219F	RELAY	

■ ENB-067 B Logic PC Board Ass'y

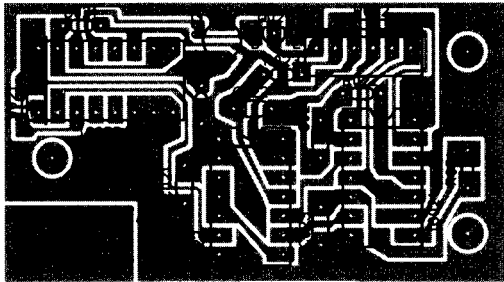

TRANSISTORS

△	ITEM	PART NUMBER	DESCRIPTION	AREA
			MAKER	
	Q021	DTC114YS	SILICON ROHM	

I. C. S

△	ITEM	PART NUMBER	DESCRIPTION	AREA
			MAKER	
	IC021	TC74HC86P	I.C. TOSHIBA	
	IC022	TC74HC27P	I.C. TOSHIBA	
	IC023	TC74HC123P	I.C.	

DIODES

△	ITEM	PART NUMBER	DESCRIPTION	AREA
			MAKER	
	D021	1SS133	SILICON ROHM	

CAPACITORS

△	ITEM	PART NUMBER	DESCRIPTION	AREA
	C021	QCF21HP-103	0.01MF 50V CERAMIC	
	C022	QFN81HJ-103	0.01MF 50V MYLAR	
	C023	QCS21HJ-101	100PF 50V CERAMIC	
	C024	QCS21HJ-101	100PF 50V CERAMIC	
	C025	QETB1HM-225	2.2MF 50V ELECTRO	

RESISTORS

△	ITEM	PART NUMBER	DESCRIPTION	AREA
	R021	QRD167J-102	1K 1/6W CARION	
	R022	QRD167J-102	1K 1/6W CARION	
	R023	QRD167J-472	4.7K 1/6W CARION	
	R024	QRD167J-564	560K 1/6W CARION	

OTHERS

△	ITEM	PART NUMBER	DESCRIPTION	AREA
	P021	E11662-101 GMV5005-006K	CIRCUIT BOARD PLUG ASSY	

△ : SAFETY PARTS

■ ENH-116 A Power Control PC Board Ass'y

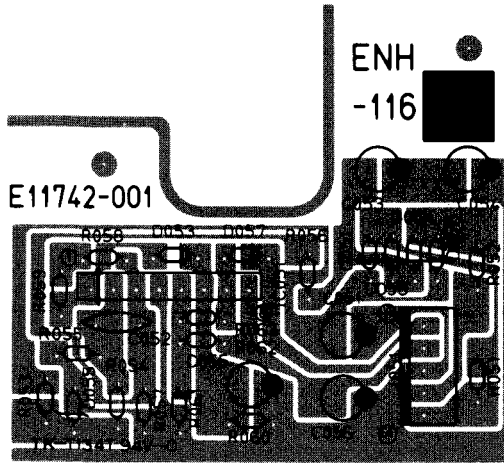

CAPACITORS

ITEM	PART NUMBER	DESCRIPTION			AREA
C051	QETB2AM-105	1MF	100V	ELECTRO	
C052	QFN81HJ-103	0.01MF	50V	MYLAR	
C053	QETB1HM-226	22MF	50V	ELECTRO	
C054	QETB1HM-226	22MF	50V	ELECTRO	
C055	QETB1EM-476	47MF	25V	ELECTRO	
C056	QETB1EM-106	10MF	25V	ELECTRO	

RESISTORS

ITEM	PART NUMBER	DESCRIPTION			AREA
R051	QRD14CJ-182S	1.8K	1/4W	UNF. CARBON	
R052	QRD14CJ-182S	1.8K	1/4W	UNF. CARBON	
R053	QRD167J-223	22K	1/6W	CARBON	
R054	QRD167J-563	56K	1/6W	CARBON	
R055	QRD167J-363	36K	1/6W	CARBON	
R056	QRD167J-823	82K	1/6W	CARBON	
R057	QRD167J-153	15K	1/6W	CARBON	
R058	QRD167J-105	1M	1/6W	CARBON	
R059	QRD167J-105	1M	1/6W	CARBON	
R060	QRD167J-824	820K	1/6W	CARBON	
R061	QRD167J-821	820	1/6W	CARBON	
R062	QRD167J-472	4.7K	1/6W	CARBON	
R063	QRD167J-105	1M	1/6W	CARBON	

I. C. S

ITEM	PART NUMBER	DESCRIPTION		AREA
			MAKER	
IC051	BA15218N	I.C.	ROHM	

OTHERS

ITEM	PART NUMBER	DESCRIPTION		AREA
J051	E11742-001 QMV5005-005K	CIRCUIT BOARD PLUG ASSY		

DIODES

ITEM	PART NUMBER	DESCRIPTION		AREA
			MAKER	
D051	1SS147	SILICON	ROHM	
D052	1SS147	SILICON	ROHM	
D053	1SS147	SILICON	ROHM	
D054	1SS147	SILICON	ROHM	
D055	MTZ9.1JC	ZENER	ROHM	
D056	1SS133	SILICON	ROHM	
D057	1SS133	SILICON	ROHM	

MC-Service

■ END-049 A Voltage Selector PC Board Ass'y

(Except U.S.A, Canada, Continental Europe, Australia, West Germany, U.K.)

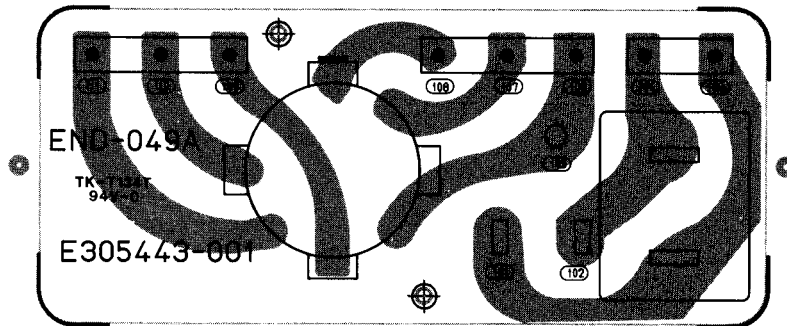

OTHERS

ITEM	PART NUMBER	DESCRIPTION		AREA
	E305443-001	CIRCUIT BOARD		
	E65508-002	TAB		
	E67764-302	WRAPPING TERMINAL		
	E67764-303	WRAPPING TERMINAL		
	QMC0242-006B	AC OUTLET		

OTHERS

ITEM	PART NUMBER	DESCRIPTION		AREA
	QSR0085-008U	VOLTAGE SELECTOR		

△ : SAFETY PARTS

■ ENH-107 □ Speaker PC Board Ass'y

Note: ENH-107 □ Varies according to the areas employed. See note (1) when placing an order.

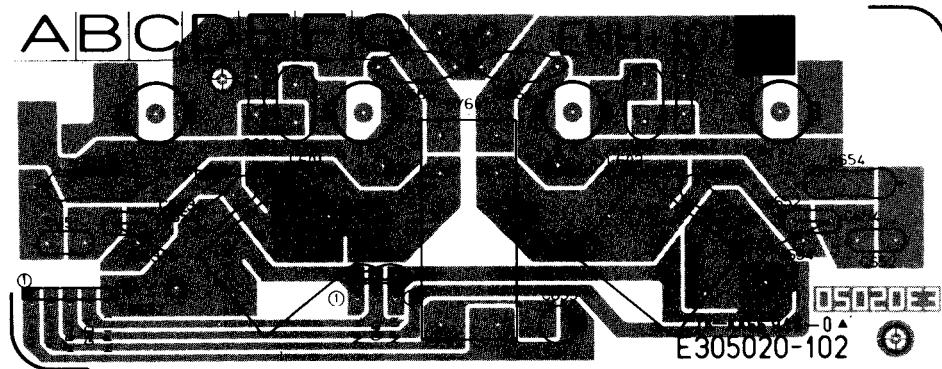

Note (1)

PC Board Ass'y	Designated Areas
ENH-107 B	U.S.A., Canada
ENH-107 C	U.S. Military Market, Australia, Continental Europe, U.K., Other Countries
ENH-107 D	West Germany

CAPACITORS

△	ITEM	PART NUMBER	DESCRIPTION			AREA
	C651	QFV81HJ-104	0.1MF	50V	T.FILM	C
	C651	QFV81HJ-223	0.022MF	50V	T.FILM	D
	C651	QFV81HJ-473	0.047MF	50V	T.FILM	B
	C652	QFV81HJ-104	0.1MF	50V	T.FILM	C
	C652	QFV81HJ-223	0.022MF	50V	T.FILM	D
	C652	QFV81HJ-473	0.047MF	50V	T.FILM	B
	C653	QFV81HJ-104	0.1MF	50V	T.FILM	C
	C654	QFV81HJ-104	0.1MF	50V	T.FILM	C
	C655	QETB1HM-105	1MF	50V	ELECTRO	
	C661	QFV81HJ-223	0.022MF	50V	T.FILM	D
	C662	QFV81HJ-223	0.022MF	50V	T.FILM	D
	C663	QCE22HP-103	0.01MF	500V	CERAMIC	D
	C664	QCE22HP-103	0.01MF	500V	CERAMIC	D

RESISTORS

△	ITEM	PART NUMBER	DESCRIPTION			AREA
△	R651	QRD125J-100	10	1/2W	UNF.CARBON	B
△	R651	QRD125J-100	10	1/2W	UNF.CARBON	C
△	R651	QRD125J-101	100	1/2W	UNF.CARBON	D
△	R652	QRD125J-100	10	1/2W	UNF.CARBON	B
△	R652	QRD125J-100	10	1/2W	UNF.CARBON	C
△	R652	QRD125J-101	100	1/2W	UNF.CARBON	D
△	R653	QRG022J-100A	10	2W	O.M.FILM	B
△	R653	QRG022J-100A	10	2W	O.M.FILM	C
△	R653	QRX022J-4R7A	4.7	2W	M.FILM	D
△	R654	QRG022J-100A	10	2W	O.M.FILM	B
△	R654	QRG022J-100A	10	2W	O.M.FILM	C
△	R654	QRX022J-4R7A	4.7	2W	M.FILM	D
△	R661	QRZ0077-4R7	4.7	1/4W	FUSIBLE	D
△	R662	QRZ0077-4R7	4.7	1/4W	FUSIBLE	D

OTHERS

△	ITEM	PART NUMBER	DESCRIPTION	AREA
		EWT011-112	TERMINAL WIRE	D
		E305020-102	CIRCUIT BOARD	
		E33754-001	BAND	
		E74366-001	PLATE	
	J604	EMBO0YP-401A	SPEAKER TERMINAL	
	L601	EQL0003-1R0	INDUCTOR	
	L602	EQL0003-1R0	INDUCTOR	
	FW601	EWR23C-50LN	FLAT WIRE	
	FW602	EWR35B-50LST	FLAT WIRE	
	RY601	ESK5D24-218	RELAY	

■ END-048 **A** AC Outlet PC Board Ass'y



OTHERS

△	ITEM	PART NUMBER	DESCRIPTION	AREA
		E305442-001	CIRCUIT BOARD	
		E65508-002	TAB	
		E67764-302	WRAPPING TERMINAL	
△		QMC0242-005B	AC OUTLET	

△ : SAFETY PARTS

■ END-040 □ Primary PC Board Ass'y

Note: END-040 □ Varies according to the areas employed. See note (1) when placing an order.

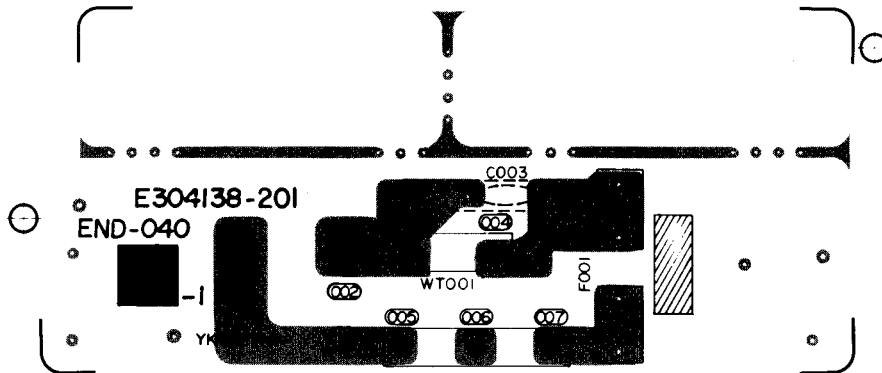

Note (1)

PC Board Ass'y	Designated Areas
END-040 A	Australia, West Germany Continental Europe
END-040 D BS	U.K.

CAPACITORS

△ ITEM	PART NUMBER	DESCRIPTION			AREA
C003	QCZ9019-472	4700PF		CERAMIC	A
C003	QCZ9019-472BS	4700PF		CERAMIC	BBS

OTHERS

△ ITEM	PART NUMBER	DESCRIPTION	AREA
	EMG7331-001	FUSE CLIP	
	E304138-201	CIRCUIT BOARD	A
	E304138-201BS	CIRCUIT BOARD	BBS
	E65508-002	TAB	
	E67132-T4R0	FUSE LABEL	
WT001	E67764-202	WRAPPING TERMINAL	
WT002	E67764-203	WRAPPING TERMINAL	

△ : SAFETY PARTS

MC-Service

Packing Materials and Parts Numbers

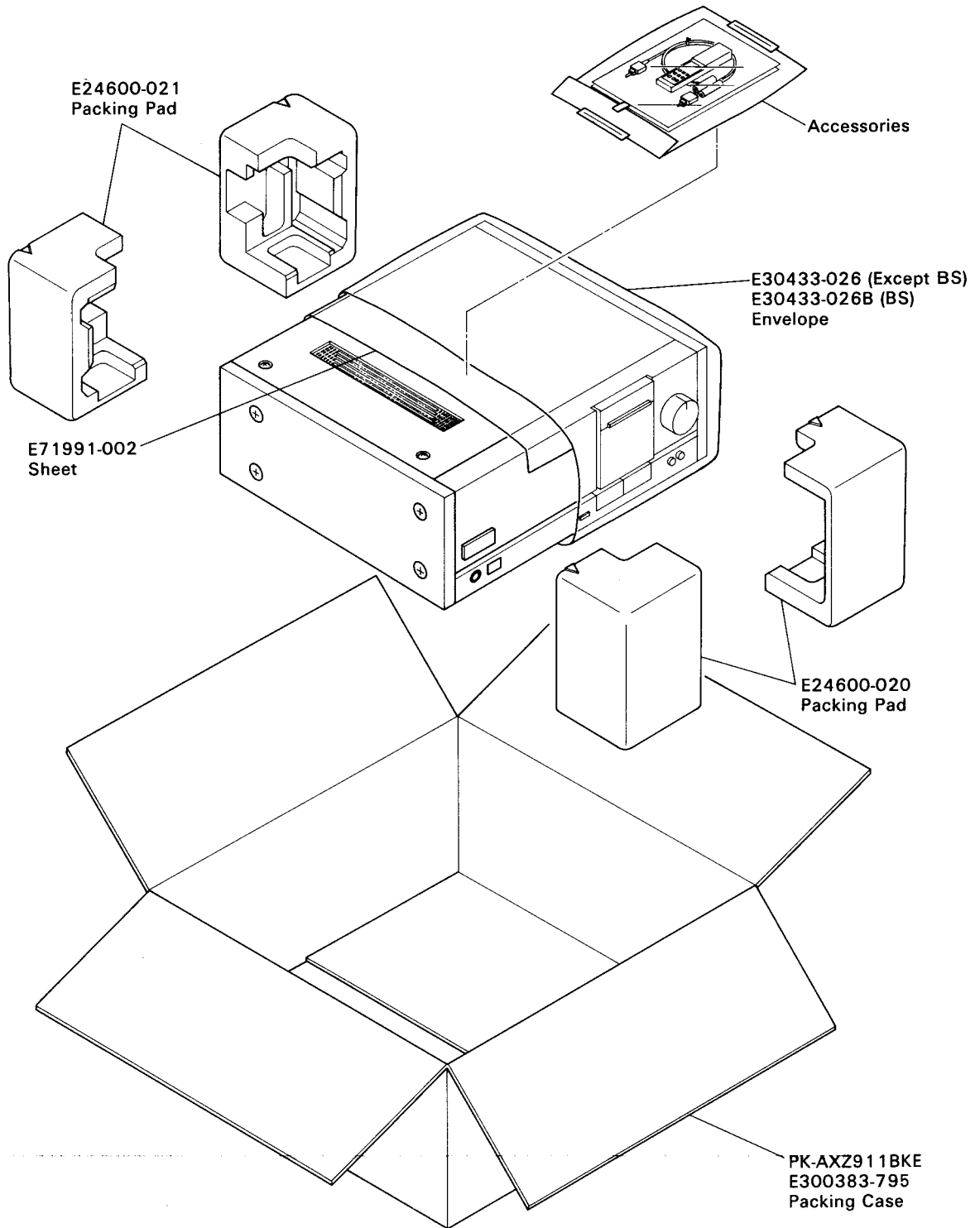

The Marks for Designated Areas	
J.....	U.S.A.
C.....	Canada
P, PG.....	U. S. Military Market
E, E F.....	Continental Europe
A.....	Australia
G.....	West Germany
BS.....	U.K.
U.....	Other Countries
No mark indicates all areas.	

Accessories List

△	Item	Part Number	Part Name	Q'ty	Description	Areas
		E30530-1428A E30530-1428ABS BT20025K BT20029C BT20048B	Instruction Book Instruction Book Warranty Card Warranty Card Warranty Card	1 1 1 1 1	for Australia	Except BS BS C A J, P, PG
		BT20060B BT20064A BT20098 BT20044E BT20046C	Warranty Card Warranty Card Warranty Card Safety Instruction Sheet Service Information	1 1 1 1 1	for New Zealand	BS G A J J, P, PG
		BT20066 BT20071A QZL1008-001 E43486-340A E72360-001	EEC Agency Service Center List FTZ Information Sheet Safety Sheet Caution Sheet	1 1 1 1 1		G, BS C G BS C
△ △		UM-4NJ-2PSA RM-SA911U QMF51A2-8R0L QMF51A2-4R0S E67142-T8R0	Battery Remote Controler Fuse Fuse Fuse Label	1 1 1 1 1		U, PG P U, PG
		E67142-T4R0 TOCP172-1MB-JV E41202-2 E41202-2B E6581-4	Fuse Label OPT. Fiver Envelope Envelope Envelope	1 1 1 1 1	for Fuse	P Exctet BS BS U, P, PG
△		E66416-003 E04056 E35497-019 E35497-017	Envelope Siemens Plug Caution Sheet Caution Sheet	1 1 1 1	220V 110V	J U, PG U, PG P

△ : Safety Parts

The Marks for Designated Areas	
J.....U.S.A.	G.....West Germany
C.....Canada	BS.....U.K.
P, PG.....U. S. Military Market	U.....Other Countries
E, EFContinental Europe	No mark indicates all areas.
A.....Australia	