

JVC

SERVICE MANUAL

COMPACT COMPONENT SYSTEM

CA-C330

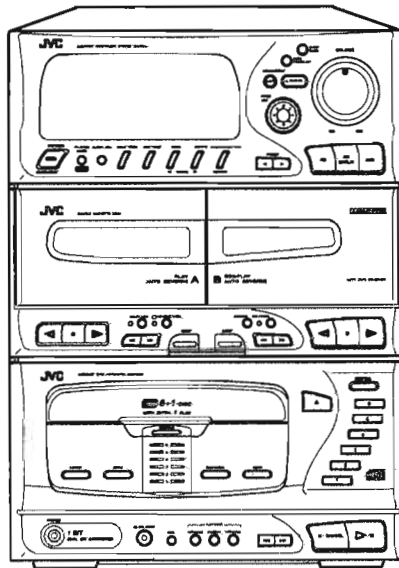
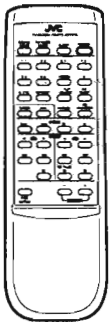

Pick up	OPTIMA-6
CD SIGNAL PROCESSOR with in 1 bit DAC	TC9284AF
CD SERVO	TA8191F

Area Suffix

A	Austraria
BS	the U.K.
C	Canada
EF	Continental Europe
EN	Scandinavia
G	Germany
GI	Italy
J	U.S.A
UT	Taiwan
US	Singapore
VX	Eastern Europe
U	Other Countries

COMPACT
disc
DIGITAL AUDIO

Contents

<i>Safety Precautions</i>	1-2	<i>Adjustment Procedures</i>	1-38
<i>Important for Laser Products</i>	1-3	<i>Block Diagrams</i>	1-43
<i>Instruction Book</i>	1-4	<i>Connection Diagram</i>	1-44
<i>Description of ICs</i>	1-17	<i>Printed Circuit Boards</i>	1-45
<i>Internal Connection for the FL</i>	1-28	<i>Schematic Diagrams</i>	1-51
<i>Disassembly Procedures</i>	1-31	<i>Parts List</i>	2-1

Safety Precautions

1. The design of this product contains special hardware and many circuits and components specially for safety purposes. For continued protection, no changes should be made to the original design unless authorised in writing by the manufacturer. Replacement parts must be identical to those used in the original circuits.
2. Any unauthorised design alterations or additions will void the manufacturer's guarantee ; furthermore the manufacturer cannot accept responsibility for personal injury or property damage resulting therefrom.
3. Essential safety critical components are identified by (Δ) on the Parts List and by shading on the schematics ,and must never be replaced by parts other than those listed in the manual. Please note however that many electrical and mechanical parts in the product have special safety related characteristics . These characteristics are often not evident from visual inspection . Parts other than specified by the manufacturer may not have the same safety characteristics as the recommended replacement parts shown in the Parts List of the service manual and may create shock , fire , or other hazards .
4. The leads in the products are routed and dressed with ties, clamps, tubings, barriers and the like to be separated from live parts, high temperature parts, moving parts and/or sharp edges for the prevention of electric shock and fire hazard. When service is required, the original lead routing and dress should be observed, and it should be confirmed that they have been returned to normal, after re-assembling.

Warning

1. Service should be performed by qualified personnel only.
2. This equipment has been designed and manufactured to meet international safety standards.
3. It is the legal responsibility of the repairer to ensure that these safety standards are maintained.
4. Repairs must be made in accordance with the relevant safety standards.
5. It is essential that safety critical components are replaced by approved parts.
6. If mains voltage selector is provided, check setting for local voltage .

Important for Laser Products

1. **CLASS 1 LASER PRODUCT**
2. **DANGER** : Invisible laser radiation when open and interlock failed or defeated. Avoid direct exposure to beam.
3. **CAUTION** : There are no serviceable parts inside the Laser Unit. Do not disassemble the Laser Unit. Replace the complete Laser Unit if it malfunctions.
4. **CAUTION** : The compact disc player uses invisible laser radiation and is equipped with safety switches which prevent emission of radiation when the drawer is open and the safety interlocks have failed or are defeated. It is dangerous to defeat the safety switches.
5. **CAUTION** : If safety switches malfunction, the laser is able to function.
6. **CAUTION** : Use of controls, adjustments or performance of procedures other than those specified herein may result in hazardous radiation exposure.

VARNING : Osynlig laserstrålning när denna del är öppnad och spärren är urkopplad. Betrakta ej strålen.

VARO : Avattaessa ja suojalukitus ohitettaessa olet alttiina näkymättömälle lasersäteilylle. Älä katso säteeseen.

ADVARSEL : Usynlig laserstrålning ved åbning, når sikkerhedsafbrydere er ude af funktion. Undgå udsættelse for stråling.

ADVARSEL : Usynlig laserstrålning ved åbning, når sikkerhedsbryteren er avslott. unngå utsettelse for stråling.

REPRODUCTION AND POSITION OF LABELS

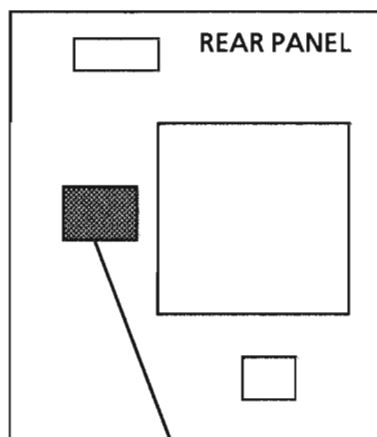

CLASSIFICATION LABEL
(Except for the U. S. A. and Canada)

CLASS 1
LASER PRODUCT

WARNING LABEL

(Except for the U. S. A.)

DANGER: invisible laser radiation when open and interlock failed or defeated. AVOID DIRECT EXPOSURE TO BEAM. (e)

VARNING: Osynlig laserstrålning när denna del är öppnad och spärren är urkopplad. Betrakta ej strålen. (s)

ADVARSEL: Usynlig laserstrålning ved åbning, når sikkerhedsafbrydere er ude af funktion. Undgå udsættelse for stråling. (d)

VARO: Avattaessa ja suojalukitus ohitettaessa olet alttiina näkymättömälle lasersäteilylle. Älä katso säteeseen. (f)

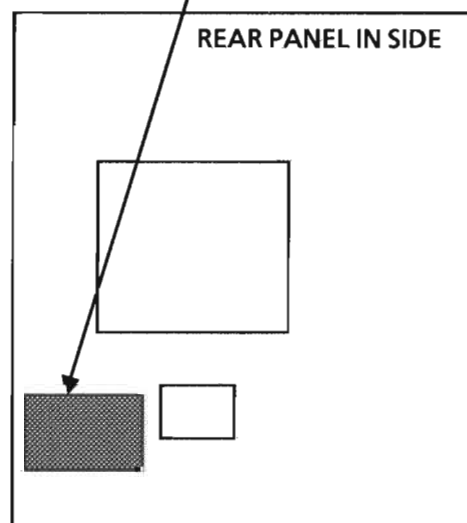

Instruction Book

Table of Contents

Features.....	1	Using the Cassette Deck.....	14
How This Manual Is Organized.....	1	Listening To a Tape.....	14
How To Put Batteries in the Remote Control.....	1	One Touch Play.....	14
IMPORTANT CAUTIONS.....	2	Regular Play.....	14
Getting Started.....	3	Fast Left And Fast Right.....	14
Connecting the Speakers.....	3	Music Scan.....	14
Connecting Auxiliary Equipment.....	3	To Find the Beginning of the Current Song.....	14
Connecting the FM And AM Antennas.....	3	To Find the Beginning of the Next Song.....	14
FM Antenna Connections.....	4	Other Useful Features of the Cassette Deck.....	15
AM (MW/LW) Antenna Connections.....	4	Recording.....	15
Using the Amplifier.....	5	Things To Know Before You Start Recording.....	15
Demonstration Function.....	5	Standard Recording.....	16
COMPULAY.....	5	To Record Any Sound Source To Tape.....	16
Tuning the CA-C330 On.....	5	CD Direct Recording.....	17
Tuning the CA-C330 Off.....	5	Tape To Tape Recording (Dubbing).....	17
Adjusting the Volume Controls.....	6	How To Use the DUBBING Button.....	17
Volume Control.....	6	Recording With the Timer.....	17
Active Bass Extension.....	6	Using the Tuner.....	18
Listening With Headphones.....	6	Listening To the Radio.....	18
Live Surround Effects.....	6	One Touch Radio.....	18
Presel S.E.A. (Sound Effect Amplifier) Effects.....	6	Tuning In a Station.....	18
Listening To Optional Equipment.....	7	Three ways to select a station.....	18
Auto Power Off.....	7	Presetting Stations.....	18
Using the CD Player.....	8	Receiving in Stereo Or Mono.....	19
To Insert Discs.....	8	Switching From FM Auto Mode To FM Mono Mode.....	19
When the CD Player Is Used For the First Time.....	8	Switching From FM Mono Mode To FM Auto Mode.....	19
To Insert Discs Into the Holder.....	8	Using the Timers.....	20
To Insert a Disc Into the Extra Tray.....	8	Clock Setting.....	20
To Play a Disc.....	9	Setting the REC (Recording) Timer.....	20
To Play Discs in the Holder.....	9	Setting the DAILY Timer.....	21
To Remove a Disc From the Holder.....	10	Setting the SLEEP Timer.....	22
To Remove a Disc From the Extra Tray.....	10	Timer Priority.....	22
To Select a Disc, Track Or Passage Within a Track.....	10	Using the Remote Control.....	23
Intro Scan.....	10	How To Use the Remote Control.....	23
Programming the Playing Order of the Tracks.....	11	Using the Numeric Key Pad.....	23
Random Play.....	11	Care And Maintenance — General Notes.....	24
Program Play.....	11	Troubleshooting.....	25
A Few Hints to Make Programming Easier.....	12	Specifications.....	26
Repeating a Selection Or the Discs.....	13		
Naming Discs.....	13		

Thank you for purchasing the JVC Compact Component Stereo System. We hope it will be a valued addition to your home, giving you years of enjoyment. Be sure to read this instruction manual carefully before operating your new stereo system. Here you will find all the information you need to set up and use the system. For questions that are not answered in the manual, please contact your dealer.

Features

- Here are some of the things that make your CA-C330 powerful and easy to use.
- ☐ To get such great sound from such a compact package as the CA-C330 has:
 - Pre-programmed live surround effects like **B. CLUB** (Binaural Club), **HALL**, **STADIUM** as well as **S.E.A.** effects like **ROCK**, **POPS**, and **CLASSIC** so you don't have to be a sound engineer to get great effects.
 - ☐ The controls and operations have been redesigned to make them very easy to use so you can spend your time listening to music.
 - With the **One Touch Operation** feature of JVC's **COMPULAY** you can turn on the CA-C330 and start the radio, the cassette deck, or the CD player with a single touch.
 - The three timers, **REC (Recording)** Timer, **DAILY** Timer, and **SLEEP** Timer are extremely easy to set.
 - The Displays are large and clear. They are organized so you can tell at a glance what's happening because functions light up as you use them, and blink to tell you they are ready. They give you some important messages like "NO DISC", and some others.

How This Manual Is Organized

- In this manual we have incorporated some special features:
- Basic information that is the same for many different functions is grouped in one place, and not repeated in each procedure. For instance, in the section on playing a CD, we do not repeat the information about setting the volume and the sound conditioning, which are talked about in the Using the Amplifier section.
 - Name of buttons and controls are written in all capital letters like this: **POWER**.
 - When we are talking about the Function, rather than the **BUTTON** or **DISPLAY**, only the first letter is capitalized.
 - The column on the left of the page is a special place to make it easier to find just what you want to know about, with little headlines announcing what each part of the page is about. Sometimes illustrations and helpful hints are placed here also.

The manual has a table of contents to help you easily look up what you want to know. We've enjoyed making this manual for you, and hope you will use it to enjoy the sound and many features built into your CA-C330.

How To Put Batteries In the Remote Control

Match the polarity (+ and -) on the batteries with the + and - markings in the battery compartment.

R6P (SUM-3)/AA (15F)



CAUTION: Handle batteries properly.

To avoid battery leakage or explosion:

- Remove batteries when the Remote Control will not be used for a long time.
- When you need to replace the batteries, replace both batteries at the same time with new ones.
- Don't use an old battery with a new one.
- Don't use different types of batteries together.

IMPORTANT CAUTIONS

1. **Installation of the Unit**
 - Select a place which is level, dry and neither too hot nor too cold (Between 5°C and 35°C or 41°F - 95°F).
 - Leave sufficient distance between the Unit and a TV.
 - Do not use the Unit in a place subject to vibrations.
2. **Power cord**
 - Do not handle the power cord with wet hands!
 - A small amount of power (1.3 watts) is always consumed as long as the power cord is connected to the wall outlet.
 - When unplugging the Unit from the wall outlet, always pull the plug, not the power cord.
3. **Malfunctions, etc.**
 - There are no user serviceable parts inside. If anything goes wrong, unplug the power cord and consult your dealer.
 - Do not insert any metallic object into the Unit.

Getting Started

Check to be sure you have all of the following things, which are supplied with the CA-C330.



If any are missing, contact your dealer immediately.

Connecting the Speakers

(Please refer to instructions for speakers as well when you connect speakers.)

- For each speaker connect one end of the speaker wire to the speaker terminals on the back of the CA-C330 and one end to the speaker.
- Open each terminal.
 - Insert the end of the speaker wire as shown (be sure to remove the insulation at the end of each wire first).
 - Close the terminals to clamp the speaker wires firmly in place.
 - Connect the red (+) and black (-) terminals of the right side speaker to the red (+) and black (-) terminals marked RIGHT on the CA-C330. Connect the red (+) and black (-) terminals of the left side speaker to the red (+) and black (-) terminals marked LEFT on the CA-C330.

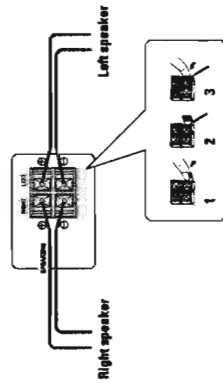

IMPORTANT: Use speakers with the correct impedance only. The correct impedance is indicated on the back panel.

CAUTION: If a TV is installed near speakers, the TV may display irregular colors. In this case, set the speakers away from the TV.

Connecting Auxiliary Equipment

CAUTION: Make all connections before plugging the Unit into an AC power outlet.

VCR or other equipment
To listen to these sources, press the AUX button.

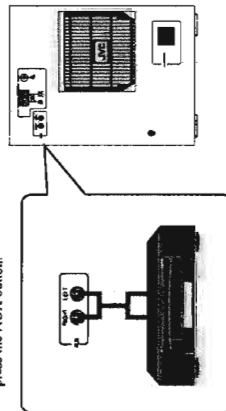

Laying Out the Unit

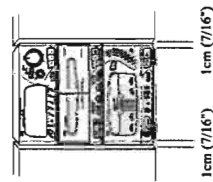

- Leave a space of at least 1 cm on both sides of the Unit and at least 10 cm at the back, for ventilation.

Connecting the FM And AM Antennas

FM Antenna Connections

- For Germany**
- Using the Supplied Wire Antenna**
The FM Wire Antenna provided can be connected to a FM 75-ohm COAXIAL as temporary measure.
Extend the supplied wire antenna horizontally.
 - Using the Coaxial Type Connector (Not Supplied)**
A 75-ohm antenna with coaxial type connector (DIN 45 352) should be connected to the FM 75-ohm COAXIAL terminal.
- For Other Countries**
- Using the Supplied Feeder Antenna**
● Attach the Feeder Antenna to the FM connector as shown in the figure.
 - Connect the FM connector to the FM 75-ohm COAXIAL terminal.
 - Using an FM 75-ohm Antenna Cable (Not Supplied)
 - Open the clamps at both sides and remove the cover.
 - Move the conductor wire from ⓐ to ⓑ using tweezers or a similar instrument (only when using coaxial cable).
 - Fix the coaxial cable and its core.
 - Put on the cover.
 - Connect the FM connector on the FM 75-ohm COAXIAL terminal.

Note: Make sure the antenna conductors do not touch any other terminals, connecting cord or the power cord in the system as this could cause poor reception.

For Other Countries
Unfold the loops of the supplied dipole FM Feeder Antenna and extend them as shown. Install them in the position and location which gives you the best FM reception.

If reception is poor, connect the outside antenna.

Before attaching a 75 ohm coaxial lead (the kind with a round wire going to an outside antenna), disconnect the supplied FM feeder antenna.

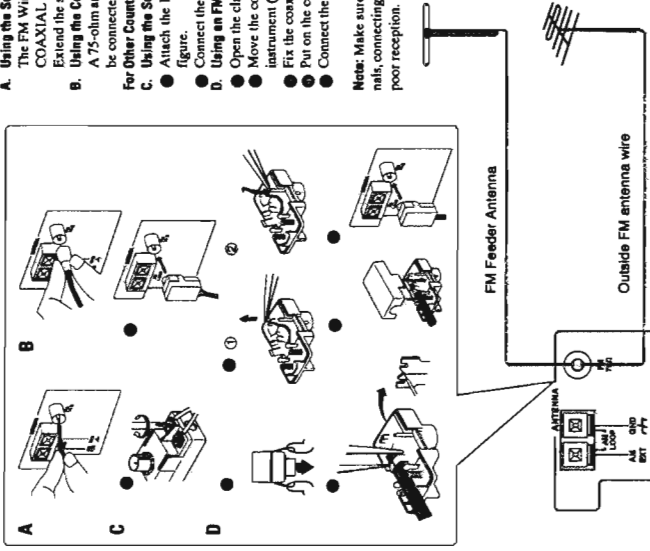

How To Strip the 75-Ohm Coaxial Cable

- Remove about 20 mm from the outside cover of the 75 ohm coaxial cable, exposing the metal mesh.
- Pull the mesh back over the cable as shown.
- Strip the insulation about 10 mm back from the central wire.
- Attach to the supplied Antenna Adaptor, as shown in the diagram above.

CAUTION: To avoid noise, keep antennas away from metallic parts of the CA-C330, connecting cord and the AC power cord.

AM (MW/LW) Antenna Connections

If reception is poor, connect the outside antenna.

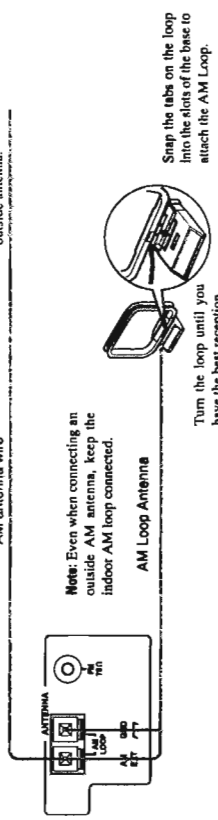

Turn the loop until you have the best reception

Snap the tabs on the loop into the slots of the base to attach the AM Loop.

Now you can plug the AC power cord into the wall outlet, and your CA-C330 is at your command!

Using the Amplifier

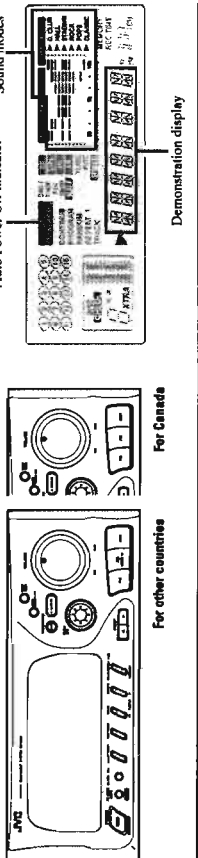

Demonstration Function

When the CA-C330 is connected to an AC power outlet, after "DEMO" flashes in the display, the Demonstration Display comes on repeatedly. The Demonstration Display proceeds as follows until it is turned off, regardless of whether the power is on or off.

- Power off → power on:** After the power has been turned on by pressing the POWER button, the Demonstration Display comes on automatically after about 1 minute. If no operation is done for about 1 minute, the Demonstration Display comes on. When doing the Sound Mode Demonstration, you can listen to the effects produced by each Sound Mode.
- Power on → power off:** After the power has been turned off by pressing the POWER button (Standby Mode), the Demonstration Display will come on after about 1 minute.

To stop the Demonstration Display, press the DEMO button (FM MODE/MUTE button) when the display is on. This will work whether the power is on or off.

The Demonstration Display will remain off until you press the DEMO button (FM MODE/MUTE button) again.

To start the Demonstration Display again, press the DEMO button (FM MODE/MUTE button) when the display is off. This will work whether the power is on or off.

- The Demonstration Display will always come on when the Unit is plugged into an AC outlet. When plugging the Unit back in once it has been disconnected, if you don't want the Demonstration Display to come on, turn it off by pressing the DEMO button (FM MODE/MUTE button) when the display is on.

COMPUPLAY

COMPUPLAY is JVC's feature that lets you control the most used functions of the CA-C330 with a single touch. One Touch Operation starts playing a CD, turns on the Tuner, plays a tape, etc. with a single press of the play button for that function. What One Touch Operation does for you is to turn the power on, then start the function you have specified. If the Unit is not ready, such as when no CD or tape is in place, the Unit still powers on so you can put in a CD or tape.

How One Touch Operation works in each case is explained in the section dealing with that function.

Turning the CA-C330 On

Press the POWER button.

- The displays come on and the red indicator on the POWER button light goes on.
- The CA-C330 comes on ready to do whatever it was doing when the power was last shut off. If the last thing you were doing was listening to a tape in Deck B, you are now ready to listen to a tape again in Deck B, or you can change to another source.
- If you were listening to the Tuner last, the Tuner comes on playing the station it was last set to.

Turning the CA-C330 Off

Press the POWER button again.

- The red indicator on the POWER button lights up and the displays blank, except for the clock display.
- A little power (13 watts) is always consumed even though power is turned off (called Standby Mode).
- To switch off the Unit completely, unplug the AC power cord from the AC outlet. When you unplug the AC power cord, the clock will reset to 0:00 (AM 12:00 for Canada) right away, and preset Tuner stations will be erased after a few days.



Adjusting the Volume Controls

Volume Control

Turn the VOLUME control to adjust the volume level of the speakers or headphones.

CAUTION: Always set the VOLUME control to MIN before turning on a connected source such as a VCR, or starting any of the other sound sources such as the Tuner, Cassette Deck or CD Player. Otherwise, the sudden blast of sound can permanently damage your hearing and/or ruin your speakers.

Active Bass Extension

This feature is designed and incorporated to reinforce the bass sound, depending on the volume level to maintain the richness and fullness of the bass. You cannot control it manually. Press the A. BASS EX. button to light the indicator if you want to use the Active Bass Extension function. To cancel this function, press the A. BASS EX. button again. The indicator will go off.

Listening With Headphones

A standard pair of headphones can be connected to the PHONES jack on the front panel. With the headphones connected, no sound will be heard from the speakers. Be sure to turn down the volume before connecting or putting on headphones, as high volume can damage both the headphones and your hearing.

Sound Effect Modes

The CA-C330 has some preset sound effects that give you control of the way your music sounds, so you can tailor it for your room and for the quality of the source. We can give you some idea of how each one affects the music, but the only way to really tell is to try them yourself. You can use only one effect at a time, selecting from the Live Surround or S.E.A. effects. Feel free to experiment!

Live Surround Effects

- With these effects, the sound coming from only two speakers approaches the quality of sound from four speakers.
- D. CLUB** Increases resonance and bass.
- HALL** Adds depth and brilliance to the sound, like in a concert hall.
- STADIUM** Adds clarity and spreads the sound, like in an outdoor stadium.

Preset S.E.A. (Sound Effect Amplifier) Effects

- Adjustments of frequency range levels have been preset as three S.E.A. effects.
- ROCK** Boosts low and high frequencies.
- POPS** Good for vocal music.
- CLASSIC** Set for wide and dynamic sound stereo systems.

To get an effect, turn the MUSIC JOG. The "SOUND MODE" indicator lights in the display, displaying the selected Sound Effect Mode and equalizing pattern.

If you select the Live surround effects, the "LIVE-S" indicator lights up on the display. If you select the S.E.A. effects, the "LIVE-S" indicator goes off.

To cancel the effect, press the SOUND EFFECT ON/OFF button; "SEA OFF" is displayed and "LIVE-S" and "SOUND MODE" or the "SOUND MODE" indicator goes off.

- While the "SOUND MODE" indicator is off, if you press the SOUND EFFECT ON/OFF button, Sound Effect is turned on. To select the mode, turn the MUSIC JOG.

When using the Remote Control, press the SOUND MODE button. Each time you press the button, the Sound Mode changes as follows:

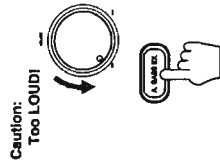

- Live Surround Effects**
- D. CLUB** (Dance Club)
- HALL**
- STADIUM**

- S.E.A. Effects**
- ROCK**
- POPS**
- CLASSIC**



Using the CD Player

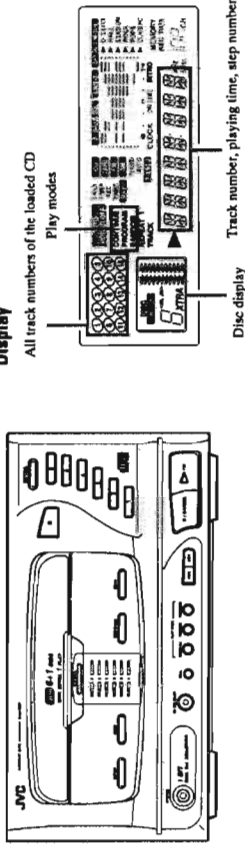

Listening To Optional Equipment

By playing the sound from auxiliary equipment through the CA-C330, you can gain control over how the music or program sounds. Once the connected equipment is playing through the CA-C330, you can apply the sound effects, make recordings, or listen with the headphones.

- First make sure that the optional equipment is properly connected to the CA-C330.
- 1. Set the **VOLUME** control to **MIN**.
- 2. Press the **AUX** button.
- 3. Start playing the selected equipment.
- 4. Adjust the **VOLUME** control to the desired listening level.
- 5. Select a sound effect mode, if you wish.

To Cancel the Setting

Change the source by starting any one of the CA-C330's built-in sound sources, such as the Tuner or CD Player.

Auto Power Off

When playing either a tape or a CD, Auto Power Off will shut the Unit off when the tape or CD comes to an end. Although Auto Power Off is very useful for shutting off the CA-C330 at night, you can also use it if you think you might forget to turn the Unit off when leaving the house or your room at other times of the day.

To Use Auto Power Off

Press the **AUTO POWER OFF** button so that the "AUTO POWER OFF" indicator lights up on the display.
To Cancel Auto Power Off
 Press the **AUTO POWER OFF** button again so that the "AUTO POWER OFF" indicator disappears from the display.

Important Information On Using Auto Power Off

- The end of CD musical performance varies depending on the play mode of the CD Player. If the play mode is "CONTINUE" or "RANDOM", when all tracks on the disc set in the CD player end, the power is automatically turned off. If the play mode is "PROGRAM", the power is automatically turned off when the last track you programmed ends.
- Auto Power Off will still work even though you press the **REPEAT** button.
- **Repeat Mode ("REPEAT" indicator lights up on the display):**
 After all tracks on the disc set in the CD Player end, the power is automatically turned off.
Repeat 1 Mode ("REPEAT 1" indicator lights up on the display):
 After the current track ends, the power is automatically turned off.
- If you press the **AUTO POWER OFF** button while the tape is playing:
 - If Reverse Mode is off (the REVERSE MODE indicator is not lit), the Unit turns off when the tape finishes playing in the < direction.

Advantages of connecting optional equipment



The CD Player in the CA-C330 has an Automatic Changer function and Extra 1 Play function. The Automatic Changer function allows you to do Continuous, Random, Program or Repeat Play of the six CDs in the CD Player's holder. The Extra 1 Play function allows you to play a CD in the same way as a CD player with one tray, using the Extra Tray. With the Extra 1 Play function, you can play one disc without having to change the discs in the holder.

- To play discs using the Automatic Changer function, first remove the disc in the Extra Tray if one is inserted. You will not be able to select tracks on the six CDs in the holder if there is one in the Extra Tray.

Here are the basic things you need to know to play a CD and locate the different selections on it. Each selection is called a track, so when we're talking about locating a track, we are also talking about how you find a certain song or performance.

The Quickest Way To Start a CD is With the One Touch Operation

- Press a Disc button (1 to 6) on the CD Player.
 - If one or more discs have been placed in the holder, when the power is turned on, the Unit will automatically play the disc whose Disc button (1-6) you have pressed. Play will start from the first track on the disc.
- Press the < /> button (or the > /< button on the Remote Control) on the CD Player.
 - If one or more discs have been placed in the holder, when the power is turned on, the Unit will automatically begin playing the first track of the disc whose number is displayed.
 - If there is no disc in the holder, the disc tray will slide out automatically when the power is turned on.

To Insert Discs

When the CD Player is Used For the First Time

Before inserting a disc, press Disc button 1. The Unit will check that no disc is inserted in the holder, to each position from 1 to 6, and turn off each Disc indicator in turn.

To Insert Discs into the Holder

1. Press the Disc button (1-6) for the disc to insert. The disc tray slides out automatically.
2. Put a CD, with its label side up, into the tray.
3. Press the < button to close the tray. The Disc indicator of the inserted disc (1-6) lights up. Repeat steps 1 to 3 to insert other discs into the holder. Up to 6 discs may be inserted.
- To play an inserted disc quickly, instead of pressing the < button, press the > /< button, or the Disc button (1-6) of the inserted disc. The tray will close automatically, and the disc will begin playing.

To Insert a Disc into the Extra Tray

1. Press the **EXTRA** button. The Extra Tray slides out.
2. Put a CD, with its label side up, into the tray.
3. Press the < button to close the tray.
 - To play an inserted disc quickly, instead of pressing the < button, press the > /< button, or the **EXTRA** button. The tray will close automatically, and the disc will begin playing.

□ 8 cm CDs cannot be placed in the holder. Place 8 cm CDs in the Extra Tray to play them, fitting them into the center groove.

When a disc is inserted, the display changes as follows:

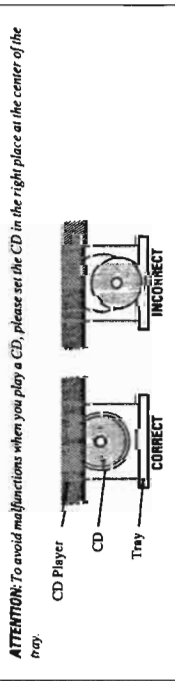
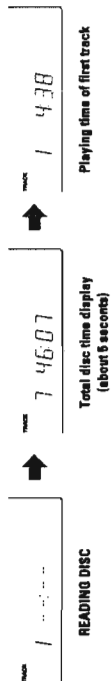

ATTENTION: To avoid malfunctions when you play a CD, please set the CD in the right place at the center of the tray.

Basics of Using the CD Player

Using the Automatic Changer function, you can do Continuous, Random, Program or Repeat Play of the discs in the holder. You can also choose preset names for the six discs using the Memo function. You can do Normal, Random, Program or Repeat Play of the disc in the Extra Tray.

- You cannot choose tracks from the discs in the holder when there is a disc in the Extra Tray. In this case, if a Disc button (1-6) is pressed, "PLEASE" and "TAKE" are displayed and the Extra Tray slides out automatically.
- To select tracks on discs in the holder, you must remove the disc in the Extra Tray.

To Play a Disc

The discs in the holder for which Disc indicators are lit play continuously, beginning with the selected disc, and moving toward disc 6. When you do normal playback of the disc in the Extra Tray, the disc starts playing from the first track.

To Play Discs in the Holder

- Prepare the disc.
 - Check that "CONTINUE" appears in the display. If "CONTINUE" does not appear, press the CONTINUE button.
 - When using the Remote Control, press the CD CHANGER button and then press the PLAY MODE button repeatedly until "CONTINUE" appears in the display.
 - Press the Disc button (1-6) of the disc to play.
 - The first track of the selected disc will begin playing.
 - The Disc No. of the selected disc will appear in the display and the Disc indicator of the disc playing will flash.
 - When the selected disc finishes playing, the next disc will begin playing automatically.
 - When the last disc has finished playing, the Unit will stop automatically.
 - When selecting the disc to play first, be sure to choose one which has a Disc No. lit in the Disc indicator. If you choose a disc whose Disc No. is unlit, "OPEN" will be appear in the display, and the tray will slide out automatically.
- To play discs continuously, beginning with the first track of the disc in the Disc display, you do not need to press a Disc button (1-6), just press the ▷/II button.

To Play a Disc in the Extra Tray

- Insert a disc into the Extra Tray.
 - The red EXTRA indicator lights up.
 - Press the ▷/II button or the EXTRA button.
 - The red EXTRA indicator flashes, and the disc starts playing.
 - When the disc in the Extra Tray finishes playing, the Unit stops automatically.
- To stop the CD, press the ■/CANCEL button (or the ■ button on the Remote Control). To pause, press the ▷/II button while the CD is playing. The ► display is flash. To cancel pause (resume playing), press the ▷/II button again.

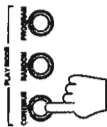

- #### To Remove a Disc From the Holder
- Press the Disc button (1-6) of the disc which you want to remove.
 - Press the ▲ button.
 - The tray with the selected disc slides out.
 - Press the ▲ button to close the tray.

To Remove a Disc From the Extra Tray

Press the ▲ button. The tray slides out. Alternatively, you can press any of the Disc buttons (1 to 6). "PLEASE" and "TAKE" appear in the display, and the tray slides out.

To Select a Disc, Track Or Passage Within a Track

- Using the Unit
- If the disc with the track you want is not playing, enter the number of the disc you want using the Disc buttons (1 to 6) on the far right of the CD Player.
 - Example: for the third disc, press 3.
 - Select the number of the track you want, using the ◀ or ▶ button.
 - The selected track starts playing.
 - Each time you briefly press and release the ◀ or ▶ button, the track changes by one.
 - Press and release the ▶ button to go ahead one track at a time.
 - Press and release the ◀ button to go back one track at a time.
 - Holding down the ◀ or ▶ button will fast forward or fast reverse the CD so you can quickly find a particular passage in the selection you are listening to.

Using the Remote Control

- If the disc with the track you want is not playing, first press the CD CHANGER button, then enter the number of the disc you want, using the numeric keys (1 to 6).
 - Example: for the third disc, press 3.
- Press the CD 10KEY button.
 - To select the disc in the Extra Tray, press the CD CHANGER button and then the EXTRA button.
- Enter the number of the track you want using the numeric keys.
 - The selected track starts playing.
 - Example: for track 5, press 5. For track 15, press +10 then 5. For track 20, press +10, then 10.
 - You can also use the ◀ or ▶ button to change tracks. However, you cannot fast forward or fast reverse to locate a particular passage using the Remote Control.

Intro Scan

You can use the Intro Scan function to search for a desired track.

- Make sure that the CD is not playing and that "CONTINUE" appears on the display.
 - If not, stop the CD Player and press the CONTINUE button on the Unit.
 - When using the Remote Control, press the CD CHANGER button, then press the PLAY MODE button until the display reads "CONTINUE".
 - Press the Disc button (1-6) of the disc on which you want to begin Intro Scan.
 - Press the INTRO button on the Unit. (When using the Remote Control, press the CD CHANGER button and then the INTRO button.)
 - "INTRO" appears in the display.
 - Press the ▷/II button.
 - Beginning with the first track on the selected disc, the first 15 seconds of each track is played continuously, one after another.
 - The Unit stops automatically after the first 15 seconds of the last track on the last disc has been played.
 - Press the ◀ button (or the ◀ button on the Remote Control) when the desired track is reached.
 - Intro Scan is canceled and normal playback starts from the selected track.
 - If you press the following buttons instead of the ◀ button (or the ◀ button on the Remote Control), Intro Scan is also canceled, and:
 - If you press the ▶ button (or the ▶ button on the Remote Control): Continuous Play starts from the next track.
 - Disc buttons (1 to 6): Continuous Play starts from the first track of the selected disc.
 - To specify a track using the Remote Control, press the CD 10KEY button and then the numeric keys (1 to +10) to enter a desired track number. Continuous Play starts from the selected track.
- To do an Intro Scan of this disc in the Extra Tray, press the INTRO button, then the ▷/II button. Intro Scan will begin on the tracks of the disc in the Extra Tray.
- To stop playing, press the ■/CANCEL button (or the ■ button on the Remote Control). To edit Intro Scan Mode, press the INTRO button. "INTRO" will disappear from the display.

With programming, you can play back tracks in any order

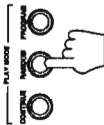

Programming the Playing Order of the Tracks

In addition to the high quality sound which makes the CD such a good way to listen to music, you can change the order in which the tracks play.

Random Play

The tracks will play in no special order when you use this mode.

To Do Random Play of the Discs in the Holder

1. Press the Disc button (1-8) of a disc which has a lighted Disc Indicator number.
 - When 1 through 5 is displayed in the DISC display go to step 3.
 - When there is a disc in the Extra Tray, "PLEASE" and "TAKE" are displayed and the Extra Tray slides out. Remove this disc before doing other operations.
 2. Press the **CANCEL** button.
 3. Press the **RANDOM** button on the Unit.
 - "RANDOM" will appear in the display.
- When using the Remote Control, press the **CD CHANGER** button and then press the **PLAY MODE** button repeatedly until "RANDOM" appears in the display.
4. Press the **▷/II** button.
 - Random Play begins.
- When all of the tracks have been played, the CD Player stops.

To Do Random Play of a Disc in the Extra Tray

1. Before starting a CD, press the **RANDOM** button on the Unit.
 - "RANDOM" will appear in the display.
 2. Press the **▷/II** button.
 - Random Play of the tracks on the disc in the Extra Tray begins.
- The CD Player stops automatically when all the tracks of the disc have been played.

Note: Random play is done on up to 32 tracks for each disc in the holder. If there are more than 32 tracks on a disc, the tracks after track 32 are not played.

Random play is done on all tracks of the disc in the Extra Tray.

To stop playing, press the **■/CANCEL** button (or the **■** button on the Remote Control).

To exit Random Mode, press the **CONTINUE** button.

When using the Remote Control, press the **CD CHANGER** button, then press the **PLAY MODE** button repeatedly until "CONTINUE" appears in the display. (The Unit must be in Stop Mode.)

- When Random Play finishes, press the **CONTINUE** button. You cannot select a disc while "RANDOM" is lit in the display.

How to program

Program Play
You can change the order in which the discs and tracks play, and select only the discs and tracks you want from among those loaded in the holder.

- You can do Program Play using either the Unit or the Remote Control, or a combination of both.
- You can program up to 20 steps in any desired order from among the discs in the player.

Programming Procedure

You can only make or change a program when the CD Player is stopped.

Programming Discs in the Holder Using the Unit

1. Press the **PROGRAM** button.
 - "PROGRAM" appears in the display.
 - Note: Wait until the display has finished showing the total time before pressing the **PROGRAM** button, or "PROGRAM" will not light up.
2. Select a disc with the disc buttons (1 to 6).
3. To select individual tracks from the selected disc, press the **◀** or **▶** button.
4. Press the **PROGRAM** button.
5. Repeat steps 2 - 4 until you have entered all the tracks you want to program.
6. Press the **▷/II** button.
 - The Unit plays the tracks in the order you have programmed them.

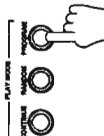

Using the Remote Control

1. Press the **CD CHANGER** button.
2. Press the **PLAY MODE** button repeatedly until "PROGRAM" appears on the display.
3. Select a disc with the numeric keys (1 to 6).
4. To select individual tracks from the selected disc enter each number by pressing the **CD 10 KEY** button and using the numeric keys (1 to 10 and +10).
 - Example: for track 5, press 5. For track 15, press +10 and 5. For track 20, press +10 and 10.

- You can also use the **◀** or **▶** button to select tracks. If you use the **◀** or **▶** button to select tracks, press the **PROGRAM** button on the CD player after selecting the desired tracks.

5. Repeat steps 1 and 3 - 4 until you have entered all the tracks you want to program.
6. Press the **▶** button.
 - The Unit plays the tracks in the order you have programmed them.

- If there is a disc in the Extra Tray, you cannot select discs in the holder. Before programming, remove the disc in the Extra Tray, if one has been inserted.

To Program a Disc in the Extra Tray

When the disc in the Extra Tray is programmed, the program total time is displayed. You can take advantage of this feature to match the program time to the recording time on a tape, for example.

- Using the Unit**
1. Press the **PROGRAM** button.
 - "PROGRAM" appears in the display.
 2. Press the **◀** or **▶** button to choose a track.
 3. Press the **PROGRAM** button.
 4. Repeat steps 2 - 3 until you have entered all the tracks you want to program.
 5. Press the **▷/II** button.
 - The Unit plays the tracks in the order you have programmed them.

- Using the Remote Control**
1. Press the **CD CHANGER** button.
 2. Press the **PLAY MODE** button repeatedly until "PROGRAM" appears on the display.
 3. Press the **CD 10 KEY** button, and then use the numeric keys (1 to 10 and +10) to choose a track.
 - Example: for track 5, press 5. For track 15, press +10 and 5. For track 20, press +10 and 10.
 - You can also use the **◀** or **▶** button to select tracks. If you use the **◀** or **▶** button to select tracks, press the **PROGRAM** button on the CD Player after selecting the desired tracks.
 4. Using the numeric keys (1 to 10 and +10), enter the track numbers of all the tracks to be programmed.
 5. Press the **▶** button.
 - The Unit plays the tracks in the order you have programmed them.

To stop playing, press the **■/CANCEL** button (or the **■** button on the Remote Control) once.

To delete the program and exit Program Mode, press the **■/CANCEL** button on the Unit repeatedly until all the program steps are deleted, and then press the **CONTINUE** button.

- You can skip to a particular program step by pressing the **◀** or **▶** button (or the **◀** or **▶** button on the Remote Control) during program play.
- To play the programmed tracks over and over, press the **REPEAT** button on the Unit. "REPEAT" lights up on the display.
 - When using the Remote Control, press the **CD CHANGER** button, then the **REPEAT** button.

Note: Pressing the **▶** button sets the Play Mode to CONTINUE.

A Few Hints to Make Programming Easier

- To Check the Program Contents (The Unit Must Be in Stop Mode)**
 - Each time you press the **CALL** button on the Unit, the program contents are shown on the display in the programmed order.
- To Change the Program Contents**
 - Press the **CALL** button on the Unit until the display shows the program step to correct. Enter the new disc number and/or track number, which will replace the one originally showing.
 - To delete a program step, press the **CALL** button until the display shows the program step to delete, then press the **■/CANCEL** button.
 - You can use both of these ways to change program steps during programming as well as later.

Using the Cassette Deck

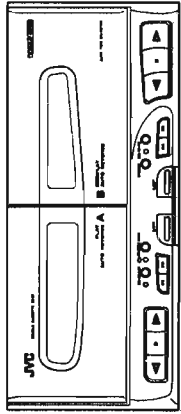

Listening To a Tape

- The Cassette Deck allows you to play, record and dub audio tapes.
- Most tapes are now recorded with the Dolby NR system, so first check which type of the Dolby NR system has been used on the tape. Only Dolby B NR is incorporated into the CA-C330.
 - With Automatic Tape Detection, you can listen to type I or II tapes without changing any settings.

One Touch Play

By pressing either the **▶** or **◀** button (or the **▶** or **◀** button on the Remote Control) on either Deck A or B, the Unit will come on, and if a tape is in the deck, it will start to play. If no tape is loaded, the Unit will come on and wait for you to insert a tape, or select another function.

Regular Play

- When the power is already on, you can use this basic procedure:
1. Press the **EJECT** button for the deck you want to use.
 2. When the cassette carrier opens, put the cassette in, with the exposed part of the tape down, toward the base of the CA-C330.
 - If the cassette carrier does not open, turn the Unit off, then back on and press the **EJECT** button again.
 3. Close the carrier gently.
 4. Press the **▶** button to play the front side, or the **◀** button to play the reverse side. The arrow indicator on the pressed button flashes and the tape starts playing.

To stop playing, press the **■** button.
To remove the tape, press the **EJECT** button.

Fast Left And Fast Right

- While the tape is stopped, press the **◀◀** button and the tape will wind rapidly onto the left side of the cassette without playing.
- While the tape is stopped, press the **▶▶** button and the tape will wind rapidly onto the right side of the cassette without playing.

Music Scan

To find the beginning of a music track during play, use the Music Scan function. Music Scan searches for blank portions that usually separate tracks, then plays the next song.
Warning: if you use Music Scan on Deck A while recording on Deck B, recording will stop.

To Find the Beginning of the Current Song

- Press the **◀◀** or **▶▶** button during play.
- Make sure that you press the **◀◀** or **▶▶** button in the opposite direction to that in which the tape is playing. Searching stops at the beginning of the current song, and the current song starts automatically.

To Find the Beginning of the Next Song

- Press the **◀◀** or **▶▶** button during play.
- Make sure that you press the **◀◀** or **▶▶** button in the same direction as that in which the tape is playing. Searching stops at the beginning of the next song, and the next song starts automatically.

Repeating a Selection Or the Discs

You can have all the discs, the program or the individual selection currently playing repeat as many times as you like.

Press the REPEAT button on the CD Player.

When using the Remote Control, press the **CD CHANGER** button, then the **REPEAT** button. Each time you press the **REPEAT** button, it cycles from function-off, which turns "REPEAT" off on the display, to "REPEAT" which will repeat all the tracks in order or according to the program you have set, and then to "REPEAT 1" which will repeat the currently playing track.

If there is no disc in the Extra Tray, Repeat Play is done of the discs in the holder (discs 1 to 6). If there is a disc in the Extra Tray, Repeat Play is done of that disc.

To exit Repeat Mode, press the **REPEAT** button so that neither "REPEAT" nor "REPEAT 1" appear on the display.

- Press the **REPEAT** button before or during Random Play to instruct the CA-C330 to continue with a different random track selection after the last selection of the last disc is played.

Naming Discs

You can give genre names to discs in the holder, to help easily identify them.

1. Press the **DISC** button (1-4) of the disc you want to name. The disc will begin playing.

2. Press the **MEMO** button to choose a name.

Each time you press the **MEMO** button, the names cycle as follows:
DISC (disc number) → BLUES → CLASSIC → HOUSE → JAZZ → OLDIES → POPS → RAP → ROCK → SOUL → (back to the beginning)

Repeat steps 1 and 2 to name other discs in the holder.

- If none of the names apply to a particular disc, use a disc number.
- A selected disc name will not change until the disc is removed or renamed.

Note: You cannot name the disc in the Extra Tray.

To check the name of a disc, press the **DISC CHECK** button.

The "CHECK" indicator flashes, and the names given to discs 1 to 6 will appear for 2 seconds each.

How to repeat a selection or all the CDs



Standard Recording

This is the basic method for recording any source. The CA-C330 also has special ways for recording CD to tape, and tape to tape, which save you time and effort, as well as give you some special effects. However, when you need to add a selection to a tape you have made, or are combining selections from several sources on one tape, use the method described below; just substitute the source you want into this procedure, such as a tape in Deck A, a CD, or the Tuner. You can also record from an auxiliary source with this procedure.

To Record Any Sound Source To Tape

Follow these steps to record from any sound source onto a tape in Deck B.

1. Insert a blank or erasable tape into Deck B.
2. Press the REC PAUSE button.
3. Press the REVERSE MODE button if you want to record on both sides of the tape. The REVERSE MODE indicator lights up.
4. Prepare the source, by, for example, tuning in a radio station, loading CDs, or turning on connected equipment.
5. On Deck B, press either the ▷ button to record on the front side, or the ◁ button to record on the reverse side.

To Pause At Any Time During the Recording Process

Press the REC PAUSE button again. Then press either the ▷ or ◁ button on Deck B to restart recording.

To Stop At Any Time During the Recording Process

Press the ■ button on Deck B.

CAUTION: During recording, DO NOT change the source or change discs. Otherwise, recording will be interrupted.

CD Direct Recording

Everything on the CD goes onto the tape in the order it is on the CD, or according to an order you have set in a program.

1. Prepare CDs. (See page 8.)
When recording from a disc in the holder, first select the disc by pressing the Disc button (1-6) of the disc to record from, then the ■/CANCEL button.
2. Set the Sound Effect Mode if you want.
Insert a cassette in Deck B to record on.
3. If you want to record on both sides of the tape, press the REVERSE MODE button on the Cassette Deck so that the REVERSE MODE indicator lights up.
4. Press the CD REC START button on the CD Player.
The Unit plays the CD and starts recording.

At the end of the tape, the CA-C330 automatically goes back to the beginning of the last selection and re-records it, this time gently fading out at the end. If you selected the Reverse Mode, the reverse side starts with the last selection on the front side and will be faded out at the end again. (A 10 second blank is created at the beginning of the reverse side.)

When the tape is finished, the Unit stops the CD Player and the Cassette Deck.

To Stop At Any Time During the Recording Process

Press the ■ button on Deck B.

Note: When the Auto Power Off function is turned on while recording a CD, the power will automatically turn OFF when either the CD or tape finishes. Be careful when the Auto Power Off function is turned on while recording a CD in Repeat Mode, as repeat will be canceled and the power will automatically turn OFF with Repeat Mode ("REPEAT" or "REPEAT !"). (Page 7)

Notes on Recording Process Started by the CD REC START button:

When the CD playback ends or you end it midway, a 4-second blank portion is allocated on the tape automatically and then the tape stops.

Do not perform any operation until the tape stops completely. If you press any button before the tape stops, further operation may be disabled. In this case, press the POWER button to turn the power off, and then press it again to turn the power back on.

For CD Direct Recording using more than one disc, use a blank tape. If you use a pre-recorded tape, pre-recorded sound may not be erased between newly-recorded tracks.

Standard recording: any source to tape

Source to tape: step by step



Misc Scan works by detecting a 4-second long blank at the beginning of each selection, so it won't work well if your tape has:

- No blank at the beginning of a track
- Noise (often caused by much use or poor quality dubbing) which fills the blank with noise.
- Long, very soft passages or pauses in a selection. The scan will detect these as 4-second long blanks. If this happens, just scan again until you reach the selection you want.

Other Useful Features of the Cassette Deck

- Use Reverse Mode to make the tape automatically reverse at the end of a side and start playing the other side. Press the REVERSE MODE button to change from Reverse Mode on (when the indicator is lit) to Reverse Mode off, or from off to on.
- Continuous Play: With the Reverse Mode indicator on, when a tape finishes playing, the Unit always checks to see if a tape is in the other deck. If there is, it automatically starts playing. This Continuous Play function works regardless of which deck starts first.
- Press the DOLBY B NR button to switch Dolby B Noise Reduction on (the indicator lights up) or off (the indicator goes off). If a tape is recorded with the Dolby B NR system, playing it back with the Dolby NR on will reduce tape noise and improve the clarity of the sound.

Dolby noise reduction manufactured under license from Dolby Laboratories Licensing Corporation. "DOLBY" and the double-D symbol are trademarks of Dolby Laboratories Licensing Corporation.

Recording

Recording onto a cassette from any of the sound sources is simple. Just place a tape in Deck B, have the source ready, make one or two settings, and you're ready to record. For each source the procedure is a little different and now we'll explain just what to do for each one. If you forget, just come back to the section which has the specific procedures you need. But first, here are a few things to make your recordings better.

Things To Know Before You Start Recording

- It may be unlawful to record or play back copyrighted material without the consent of the copyright owner.
- Press the DOLBY B NR button — the indicator lights up — to reduce tape hiss, except when dubbing tapes, since Dolby NR is inactive in Dubbing Mode regardless of the setting of DOLBY B NR. The dubbed tape automatically contains the same processing as the source tape.
- The recording level, which is the volume at which the new tape is being made, is automatically set correctly, so it is not affected by the VOLUME control on the CA-C330. Thus, during recording you can adjust the sound you are actually listening to without affecting the recording level.
- Two small tabs on the back, one for side A and one for side B, can be removed to prevent accidental erasure or re-recording. To record on a cassette with the tabs removed, you must cover the holes with adhesive tape first. However, when a type I tape is used, only cover part of the hole as shown, since the other part of the hole is used to detect the tape type.



When recording, you can use the Sound Effect Modes to condition the music as it is recorded. But when recording using CD Direct, once recording has started, these settings cannot be changed.

Type I and Type II tapes can be used for recording.

CAUTION: If recordings you have made have excessive noise or static, the Unit may be too close to a TV which was on during the recording. Either turn off the TV or increase the distance between the TV and the CA-C330.

Except for Cassets

If you are recording an AM (MW/LW) broadcast and you hear interference, move BEAT CUT switch on the back panel from position 1 (the normal mode) to position 2.

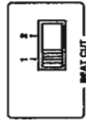

More useful things to know:

- Reverse Mode
- Continuous Play



- Dolby NR



What can you record?

- Tapes
- Radio
- CDs
- Connected source

Copyright

Reduce hiss — Dolby NR

Recording level

Erasure protection

Recording sound mode

Usable tape type

Tape to tape dubbing:
Introduction

Recording from one tape to another is called dubbing. You can dub tapes simply, with just a single button.

- To dub both sides of a tape, start from side A for both Deck A and Deck B, and press the REVERSE MODE button so that the REVERSE MODE indicator lights up.
- It is preferable that the type of tape (Type I or Type II) you record from be the same as the type you record onto.

How To Use the DUBBING Button

- Insert the source cassette you want to copy from into Deck A for playback.
- Insert the blank or erasable cassette you want to copy onto in to Deck B for recording.
- Press the DUBBING button.
- Deck A and Deck B will start simultaneously.
- To stop:
 - Press the button on Deck B. Recording on Deck B can be paused by Rec Mute.
 - Press the button on Deck A and Deck B will stop simultaneously.

Dolby NR is inactive in dubbing mode regardless of the setting of DOLBY B NR. The dubbed tape automatically contains the same processing as the source tape.



Using the Tuner

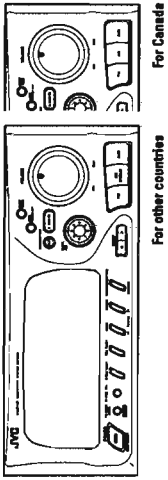

Display

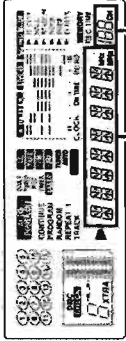

Band display, Frequency display, Preset channel

Listening To the Radio

You can listen to both FM and AM (MW/LW) stations. Stations can be tuned in manually, automatically, or from preset memory storage.

- Before listening to the radio:
 - Check that both the FM and AM (MW/LW) antennas are firmly connected.

One Touch Radio

Just press the FM button to turn on the Unit and start playing the most recent FM station tuned in, or press the AM (MW/LW) button to listen to the most recent AM (MW/LW) station tuned in.

- You can switch from any other sound source to the radio by pressing either the FM or AM (MW/LW) button.

Tuning In a Station

Press the FM or AM (MW/LW) button to turn on the radio. The display shows the station frequency tuned in.

Three ways to select a station

- Press the TUNING < or > button repeatedly to move from frequency to frequency until you find the one you want.
 - Hold down the TUNING < or > button, the frequency starts changing on the display. When a station is tuned in, "TUNED" lights up on the display and the frequency stops changing.
 - (Possible only after presetting stations.) Press once and release the PRESET < or > button to go to the next preset station, or hold the PRESET < or > button to cycle through the preset stations; release the button when the preset station you want shows on the display.
- You can also use the Remote Control to tune in preset channels:
- Press the TUNER button so that you can receive the most recent station tuned in.
 - Select the station by entering the preset number in the numeric keys of the Remote Control.

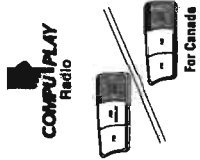

Three ways to tune in a station

How to preset FM and AM radio stations



Presetting Stations

You can store up to 40 of your favorite radio stations (FM and AM (MW/LW)) in memory, giving you quick, easy access to the stations.

- Select a band by pressing either the FM or AM (MW/LW) button.
- Press the TUNING < or > button to tune in a station. On the display, "MEMORY" will blink for 5 seconds.
- Press the MEMORY button on the Tuner. During these 5 seconds while "MEMORY" is blinking, you can assign a channel number to the station and enter it into the memory.
- Select a channel number by pressing the PRESET < or > button until you find the channel number you want.
- Press the MEMORY button and the station will be assigned to the channel number showing on the display. If a station has been previously stored using the same channel number, this will be erased and the newly selected station will be stored.
- If "MEMORY" in the display goes off, start again from step 3.
- Repeat steps 1 - 5 for each station you want to store in memory with a preset number.

Caution: If the Unit is unplugged or if a power failure occurs, the preset stations stored in memory may be lost.

Recording With the Timer

The Cassette Deck can be set to record a tape automatically. This is especially useful for recording broadcasts when you are not at home, or late at night when you are asleep.

- Insert a cassette for recording into Deck B.
- Set the REC Timer, by following the steps in "Setting the REC (Recording) Timer" (Page 20).

Using the Timers

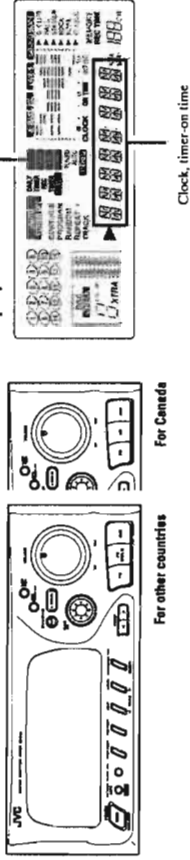

Three Timers:

- REC Timer
- DAILY Timer
- SLEEP Timer

The timers let you control recording and listening functions automatically.

- **REC (Recording) Timer** — Unattended recording of radio broadcasts. You can set the starting time and length of the recording.
- **DAILY Timer** — Wake up to music from any source.
- **SLEEP Timer** — Fall asleep and have your CA-C330 turn off automatically after a certain length of time.

Clock Setting

The timers depend on the clock; the clock must be right for the timers to work as you expect. Note that the clock must be set, or the timers cannot be set.

Setting the Clock

1. Press the **CLOCK ADJ.** button.
2. Set the hour by pressing the **HOUR** button. Each time you press the button, the hour advances by one. Hold the button down, and the hour displayed will advance continuously, until you release the button.
3. Set the minutes by pressing the **MINUTE** button. Each time you press the button, the minutes advance by one. Hold the button down, and the minutes advance in ten minutes increments until you release the button.
4. Press the **CLOCK ADJ.** button again and the clock is set for the hour and minutes you have selected, starting from zero seconds.

Caution: If there is a power failure, the clock loses its setting. The display shows "0:00" ("AM 12:00" for Canada), and the clock must be reset.

Setting the REC (Recording) Timer

With the Recording Timer you can make a tape of a radio broadcast automatically whether or not you are home. For the timer to work correctly, you need to make sure of the following in addition to setting the time for the Tuner and Cassette Deck to come on:

- You can set the Recording Timer whether the Unit is on or off.
- The tape you want to record onto must be in Deck B.
- The radio station whose program you want to tape must be the last one played before the timer comes on.

Procedure For Setting the Recording Timer

1. Press the **REC TIMER** button so that "REC TIMER" blinks on the display. As long as it is blinking, you can continue with the setting process.
 - If you wait too long, and it stops before you are done, just press the **REC TIMER** button twice and start over.
2. Set the time you want the radio to come on, and put a tape in Deck B to record on. Press the **HOUR** button to set the hour and the **MINUTE** button to set the minute.
3. Press the **SOURCE/REC TIME** button to set the length of time for the recording. Each time you press this button, the duration increases by one minute. If you hold the button down, it will advance in ten minute increments up to 120 minutes, which is the maximum time you can set.
 - At the end of the set length of time the radio and Deck B will shut off.

IMPORTANT!
Set your clock



Receiving In Stereo Or Mono

The CA-C330 can receive FM broadcasts in either stereo or mono. When "AUTO" lights up on the display, the Unit automatically receives broadcasts in the mode they are transmitted. (When a stereo broadcast is received, "STEREO" lights up on the display.) Furthermore, you won't hear noise while tuning in stations. Usually, leaving the Unit in Auto Mode, with "AUTO" lit, gives you the best reception.

While receiving an FM broadcast, the FM Mode can be switched between Auto and Mono with the FM MODE/MUTE button (DEMO button), as explained below.

Switching From FM Auto Mode To FM Mono Mode

When the Demonstration Display is On
Press the FM MODE/MUTE button (DEMO button) twice.

When the Demonstration Display is Off

Press the FM MODE/MUTE button (DEMO button) three times.
When "MONO" is lit up in the display, press this button to switch the FM Mode between Auto and Mono.

Switching From FM Mono Mode To FM Auto Mode

When the Demonstration Display is On
Press the FM MODE/MUTE button (DEMO button) twice.

When the Demonstration Display is Off

Press the FM MODE/MUTE button (DEMO button) three times.
When "AUTO" is lit up in the display, press this button to switch the FM Mode between Mono and Auto.

Note: The Demonstration Display will always turn off when the FM Mode is switched from Mono to Auto or vice versa.

- Pressing the FM MODE/MUTE button on the Remote Control switches between FM Auto Mode and FM Mono Mode, no matter what is in the Demonstration Display.





4. Press the REC TIMER button again, or wait 6 seconds. The set contents are displayed for a few seconds and the "REC TIMER" indicator lights up. The Unit will memorize the setting. When the set time comes, the CA-C330 turns the power on and records the broadcasting station you selected last, before turning the power off.
 - If you press any button while the Recording Timer is operated, the recording will stop.

Before the Set Time Comes

- Check that tape direction is correct. This is important especially when Reverse Mode is off.
- Set Reverse Mode on if you want to record on both sides of the tape.
- Select the Sound Mode if you want to record with one of the Sound Mode (D. CLUB, HALL STADIUM, etc.).
- Set the VOLUME control to MIN so that no sound comes out from speakers when the recording timer switches on the CA-C330. This is important especially if you will be out during the recording.

It is very easy, and can be very disappointing, to forget to put in a tape, or to accidentally leave a tape in Deck B you don't want recorded over. Although this happens to almost everyone at one time or another, we hope it won't happen to you!

To Change the Recording Timer Setting

Press the REC TIMER button twice ("REC TIMER" reappears) and make any changes you want. Press the REC TIMER button again so that "REC TIMER" goes off on the display.



Setting the DAILY Timer

With this timer you can wake up to music from a CD, tape or your favourite radio program.

- You can set the DAILY Timer whether the Unit is on or off.

Procedure For Setting the DAILY Timer

1. Press the DAILY TIMER button so that "DAILY TIMER" blinks on the display.
 - Press the HOUR button to set the hour and the MINUTE button to set the minute.
2. Press the SOURCE/REC TIME button to set the source.
 - Each time you press this button, the display shows one of the four possible sources: CD, TAPE, FM or AM.
 - Leave the one you want lit, but select within 5 seconds.
 - If you select FM or AM as the source, the last played station is the one which comes on at the set time.
 - If the CD is the source, when the set time comes, the CA-C330 plays in the Play Mode you set before turning the power off.
3. Press the DAILY TIMER button again, or wait 6 seconds. The set contents are displayed for a few seconds and the "DAILY TIMER" indicator lights up. The Unit will memorize the setting.
4. Turn the power off. When the set time comes, the CA-C330 turns on, plays the source you have selected for 60 minutes, and then the Unit turns off.
5. If you press any button while the DAILY Timer is being activated, the Unit will not turn off automatically after 60 minutes.

Before Turning Off the Unit

- If the source is a tape:
 - Check that the tape direction is correct. This is important especially when Reverse Mode is off.
 - Deck B has priority, so if tapes are in both decks, the tape in Deck B plays first.
 - Set Reverse Mode on if you want to play both sides of the tape.
 - If you're not home at the designated time, be sure to set the volume level to minimum.
- Select the Sound Mode if you want to listen using a Sound Mode (D. CLUB, HALL STADIUM, etc.).
- Set the volume to an appropriate level.

To change the DAILY Timer setting

Press the DAILY TIMER button twice ("DAILY TIMER" reappears) and make any changes you want. Press the DAILY TIMER button again so that "DAILY TIMER" goes off on the display.

Setting the SLEEP Timer

Use the Sleep Timer to turn the Unit off after a certain number of minutes when it is playing. By setting this timer, you can fall asleep to music and know your Unit will turn off by itself rather than play all night.

- You can only set the Sleep Timer when the Unit is on and a source is playing.

To set the SLEEP Timer, follow this procedure:

1. With the CA-C330 on and a source playing, press the SLEEP TIMER button. The "SLEEP" indicator on the display will start blinking.
 - Each time you press this button while the "SLEEP" indicator is blinking, it changes the number of minutes shown on the display in this sequence:
→ 10 → 20 → 30 → 60 → 90 → 120 → Sleep Timer off → (back to the beginning)
2. Set the length of time you want the source to play before shutting off.
 - Each time you press this button while the "SLEEP" indicator is blinking, it changes the number of minutes shown on the display in this sequence:
→ 10 → 20 → 30 → 60 → 90 → 120 → Sleep Timer off → (back to the beginning)

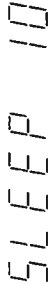

When the number of minutes you want shows on the display, just wait 5 seconds until the indicator stops blinking, and is lit steadily.

The Unit is now set to turn off after the number of minutes you set.

To Change the SLEEP Timer Setting

Press the SLEEP TIMER button until the number of minutes you want appears on the display.

To Cancel the SLEEP Timer Setting

Press the SLEEP TIMER button until the "SLEEP" indicator goes off on the display. Turning off the Unit also cancels the SLEEP Timer.

Timer Priority

Since each timer can be set independently, you may wonder what happens if the settings overlap. Here are the priorities for each timer:

- The Recording Timer always has priority. This means that:
 - If another timer is set to come on during a time when the Recording Timer is operating, the other timer just won't come on at all, so you will always get the entire program on tape.
 - If the Recording Timer is set to come on while another timer is operating, the other timer will shut off 10 seconds before the Recording Timer is set to turn on, and the Recording Timer will then take over.
- The SLEEP Timer has priority over the DAILY Timer. This is important because if you set the SLEEP Timer to start before and then end after the DAILY Timer would start, the DAILY Timer doesn't come on. So if you want your alarm to go off as scheduled, be sure the SLEEP Timer shuts off before the DAILY Timer is set to turn on the Unit.

Using the Remote Control

How To Use the Remote Control

The Remote Control makes it easy to use many of the functions of the CA-C330 from a distance of up to 23 feet away. You need to point the Remote Control at the remote sensor on the CA-C330's front panel.

- Most of the buttons on the Remote Control do just what the ones on the CA-C330 do.
- A few functions are available only by using the Remote Control, as described below.

Using the Numeric Key Pad

The numeric key pad is used to specify a CD, a CD track or the number you have assigned to a preset radio station. To enter a number using the numeric key pad, follow these steps:

- Before using the numeric key pad, check to see whether the numeric key pad is functioning to operate the CD Player or Tuner. This depends on which button on the Remote Control you have pressed before using the numeric key pad. For example, if you press the TUNER button before the numeric key pad, it can select a preset station. Pressing the CD CHANGER button enables you to select a CD and also to operate the INTRO, REPEAT, and PLAY MODE buttons. If you press the CD TURKEY button, it can select a CD track.
- For numbers between 1 and 10, just press the button with the number you want.
- For numbers from 11 to 20, first press the +10 key, then the ones digit of the number you want — to get 15, first press +10, then 5. For 20, press +10 and 10.
- For numbers from 21 to 30, press the +10 key twice; then press the ones digit — to get 25, press +10 +10 and 5. For 30, +10 +10 and 10.
- For numbers from 31 to 40, press the +10 key three times; then the ones digit of the number you want — to get 32, press +10 +10 +10 and 2. For 40, press +10 +10 +10 and 10.

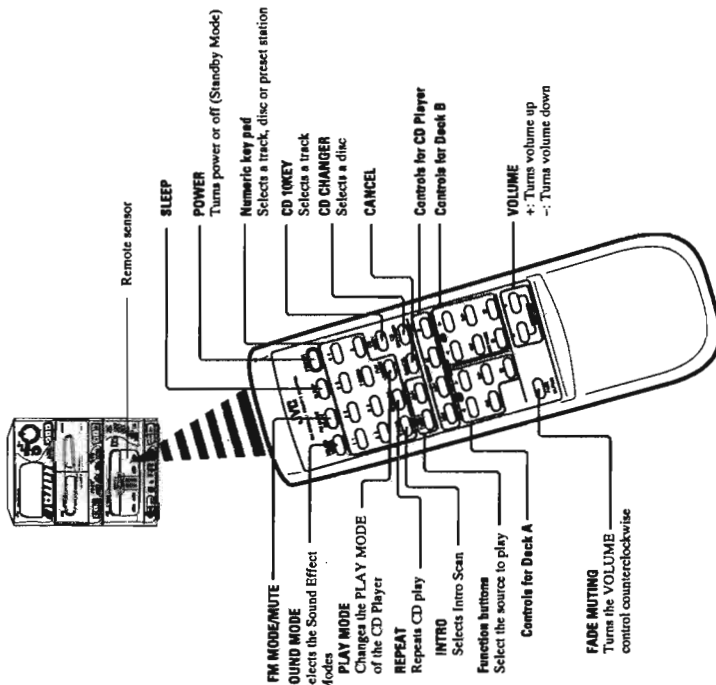

Care And Maintenance — General Notes

Compact Discs

Handle your compact discs, cassette tapes, and Cassette Deck carefully, and they will last a long time.



- Remove the CD from the case by holding it at the edges while pressing the center hole lightly.
- Do not touch the shiny surface of the CD, or bend the CD.



- Put the CD back in its case after use to prevent warping.
- Be careful not to scratch the surface of the CD when placing it back in the case.
- Avoid exposure to direct sunlight, temperature extremes, and moisture.



- A dirty CD may not play correctly. If a CD does become dirty, wipe it with a soft cloth in a straight line, from center to edge.

CAUTION: Do not use any solvent (for example, conventional record cleaner, spray thinner, benzine, etc.) to clean a CD.

Moisture Condensation



- Moisture may condense on the lens inside the Unit in the following cases:
 - After starting the heating in the room.
 - In a damp room.
 - If the unit is brought directly from a cold to a warm place.

Should this occur, the Unit may malfunction. In this case, leave the unit turned on for a few hours until the moisture evaporates, unplug the AC power cord, and then plug it in again.

In general, you will have the best performance by keeping your tapes, CDs, and the mechanism clean.

- Store tapes and CDs in their cases, and keep them in cabinets or on shelves.
- Keep the Cassette Deck's tape doors and the CD trays closed when not in use.

Cassette Tapes



- If the tape is loose in its cassette, take up the slack by inserting a pencil in one of the reels and rotating.
- If the tape is loose, it may get stretched, cut, or caught in the cassette.



- Do not touch the tape surface.



- Do not store the tape:
 - In dusty places
 - In direct sunlight or heat
 - In moist areas
 - On a TV or speaker
 - Near a magnet

Cassette Deck

- If the heads, capstans, and pinch-rollers of the Cassette Deck become dirty, the following will occur:
 - Loss of sound quality
 - Fading
 - Incomplete erasure
 - Difficultly recording
- Clean the heads, capstans, and pinch-rollers using a cotton swab moistened with alcohol.

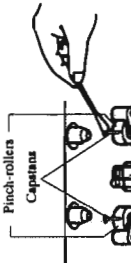

- If the heads become magnetized, the Unit will produce noise or lose high frequencies.
- To demagnetize the heads, turn off the Unit, and use a head demagnetizer (available at electronics and record shops).

Troubleshooting

- If you are having a problem with your CA-C330, check this list for a possible solution before calling for service.
- If you cannot solve the problem from the hints given here, or the Unit has been physically damaged, call a qualified person, such as your dealer, for service.

Symptom	Possible Cause	Action
No sound is heard.	Connections are incorrect, or loose.	Check all connections and make corrections. (See pages 3 - 4.)
Unable to record.	Cassette record protect tabs are removed.	Cover holes on back edge of cassette with tape.
Poor radio reception	The antenna is disconnected. The AM Loop Antenna is too close to the Unit. The FM Wire Antenna is not properly extended and positioned.	Re-connect the antenna securely. Change the position and direction of the AM Loop Antenna. Extend FM Wire Antenna to the best reception position.
The CD skips.	The CD is dirty or scratched.	Clean or replace the CD.
Unable to operate the Remote Control.	The path between the Remote Control and the sensor on the Unit is blocked. The batteries have lost their charge.	Remove the obstruction. Replace the batteries.
The CD tray cannot be operated.	The main AC power cord is not plugged in.	Plug in the AC power plug.
The CD does not play.	The CD is upside down.	Put the CD in with the label side up.
Operations are disabled.	The built-in microprocessor has malfunctioned due to external electrical interference.	Unplug the Unit then plug it back in.
The cassette door cannot be opened.	During tape playing, the power cord was unplugged.	Plug in the power cord and press eject.

Specifications

Amplifier Section Output Power	30 watts per channel, min. RMS, both channels driven, into 6 ohms from 40 Hz to 20 kHz, with no more than 0.5% total harmonic distortion. (for Canada)	Tuner Section FM Tuner Tuning Range AM Tuner Tuning Range MW	87.5 - 108.0 MHz 530 - 1,710 kHz (only for Canada) 522 - 1,629 kHz (for other countries) 144 - 288 kHz (except for Canada)
(IEC 268-3/DIN)	30 watts per channel, min. RMS, both channels driven, into 6 ohms at 1 kHz with no more than 0.9% total harmonic distortion. (for other countries)	LW	245 x 329 x 343 mm (W/H/D) 8.6 kg (19 lbs)
Input Sensitivity/Impedance (1 kHz) AUX	300 mV/47 kohms	Dimensions	
Cassette Deck Section Frequency Response Type II (CO) Type I (NORMAL) Wow And Flutter	30 - 16,000 Hz 30 - 15,000 Hz 0.09% (WRMS)	Weight	
CD Automatic Changer Section CD Capacity Dynamic Range Signal-To-Noise Ratio Wow And Flutter	6 discs + EXTRA 90 dB 90 dB Unmeasurable	Accessories AM (MW/LW) Loop Antenna (1) Remote Control (1) Batteries RGP (SUM-3)/AAA (13F) (2) FM Wire Antenna (only for Germany) (1) FM Feeder Antenna (except for Germany) (1) FM Antenna Adaptor (except for Germany) (1)	
		Power Specifications (for Canada only) Power Requirements Power Consumption	AC 120 V ~, 60 Hz 1.0 watts (in standby mode) 1.3 watts (in standby mode)
		Power Specifications (for other areas) Power Requirements Power Consumption	AC 230 V ~, 50 Hz 1.0 watts 1.3 watts (in standby mode)

Design and specifications are subject to change without notice.

Description of ICs

■ MN172412J5Z(IC804) : System Controller

1. Terminal Layout

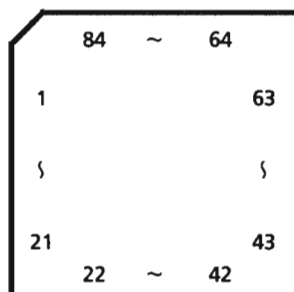

2. Key Matrix

	KEY IN 0 (PIN48)	KEY IN 1 (PIN49)	KEY IN 2 (PIN50)	KEY IN 3 (PIN51)
KEY OUT 0 (PIN52)	FM MODE / MUTE	CLOCK ADJ	DAILY TIMER	REC TIMER
KEY OUT 1 (PIN53)	HOUR TU <	MINUTE TU >	SOURCE / REC TIME MEMORY	PRESET <
KEY OUT 2 (PIN54)	PRESET >	FM	AM	SLEEP TIMER (except U,US,UT)
KEY OUT 3 (PIN12)	REPEAT	INTRO	CD REC START	CALL
KEY OUT 4 (PIN11)	DICK CHEK	MEMO	CONTINUE	RANDOM
KEY OUT 5 (PIN10)	PROGRAM	⏮	⏭	■ / CANCEL
KEY OUT 6 (PIN9)	▶ / ⏸	▲	5	6
KEY OUT 7 (PIN8)	EXTRA	4	3	2
KEY OUT 8 (PIN7)	1	---	---	---

3. Pin Functions

Pin No.	Symbol	I/O	Function	Pin No.	Symbol	I/O	Function
1~3	1G~3G	O	FL grid control signal	57	DATA	I/O	Control,Status data I/O for IC801
4	LSI ON	O	ON signal for CD LSI (IC801)	58	SCK	O	Click output for IC801
5	INH	I	Inhibit signal input for tuner controller	59	CHREQ	I	Input the "mecha. data request" to IC801
6	CS	I	Chip select terminal for tuner controller	60	STEREO	I	Stereo mode signal input from IC012
7~12	KO8~KO3	O	Key matrix output	61	TUNED	I	TUNED indicator on signal input from tuner P.C.B.
13,14	DCS IN,OUT	I/O	DCS signal input / output	62	T.CE	O	Chip enable signal output for IC121
15~22	S24~S17	O	FL segment control signal	63	T.CLK	O	Clock output for IC121
23	VDISP	-	Power supply for FL display	64	IFDATA	O	IF data output for IC121
24~39	S16~S1	O	FL segment control signal	65	T.DATA	I	Data input from IC121
40~43	BUS0~ BUS3	I/O	CD bus command / data input and output (IC601)	66	T.MUTE	I	Mute signal input from tuner P.C.B.
44	CCE	O	CD bus data chip enable (IC601)	67	TU TEST	I	Test mode input for tuner controller
45	BUCK	O	CD bus clock output (IC601)	68	RESET	I	Reset signal input for tuner controller
46	CD RESET	O	CD reset signal output (IC601)	69	X1	-	Connected to ground
47	RESTSW	I	CD rest switch signal input	70	X2	-	Non connection
48~51	KI0~KI3	I	Key matrix input	71	VSS	-	Connected to ground
52~54	KO0~KO2	O	Key matrix output	72,73	OSC2,1	I/O	Oscillation terminal
55	CD TEST	I	CD TEST mode input	74	VDD	-	Power supply
56	CHST	O	Strobe signal output for IC801	75~84	13G~4G	O	FL grid control signal

CA-C330

■ HD404719A62FS (IC901) : Deck / Amp. Controller

1. Terminal Layout

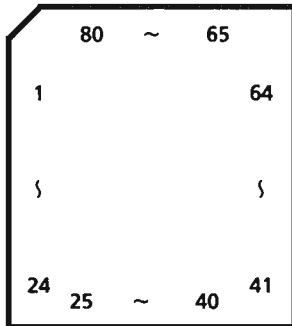

2. Pin Functions

Pin No.	Symbol	I/O	Function	Pin No.	Symbol	I/O	Function
1,2	IN6,7	I	Mode switch signal input	36	REV I	O	Reverse mode indicator control signal
3	PRT	I	Detection for protector	37	DOL I	O	Dolby indicator control signal
4	AD GND	-	Ground	38,39	AFI,ARI	O	Forward / reverse indicator control signal for A deck
5	A.RES	I	Amp. reset signal input	40	P.LED	O	Power LED control signal
6,7	OSC1,2	I/O	Oscillation terminal	41,42	BFR,BRR	O	Forward / reverse control signal for B deck's reel motor
8,9	GND	-	Connection to the ground	43,44	BRC,BFC	O	Forward / reverse control signal for B deck's cam motor
10	NC	-	Non connection	45,46	AFR,ARR	O	Forward / reverse control signal for A deck's reel motor
11	TEST	-	Test mode select terminal	47,48	ARC,AFC	O	Forward / reverse control signal for A deck's cam motor
12	VCC	-	Power supply	49	GND	-	Connection to the ground
13	PBMT	O	Deck playback muting signal output	50~52	ACS2~0	I	Cam switch input signal for A mech.
14,15	ECHO1,2	O	Echo level control signal output	53~55	BCS2~0	I	Cam switch input signal for B mech.
16,17	AMC,BMC	O	A mech. and B mech. reel motor control signal output	56	FADE	O	FADE mode control signal output
18	CAP	O	Capstan motor control signal output	57,58	JOG2,1	I	JOG dial signal input
19	A/B	O	A/B select signal output for IC304	59,60	DCS IN/OUT	I/O	DCS signal input / output terminal
20	NC	-	Non connection	61	RM	I	Remote control signal input
21,22	APLS,BPLS	I	Pulse signal input from hall IC	62	MSI	I	Music scan signal input
23	RMT	O	Rec. mute signal output for IC304	63,64	B,A	O	Deck A / B select signal output
24	NR	O	NR on signal output for IC304	65	LATCH	O	Latch signal output for IC402
25	REC	O	Recording mode signal output for IC304	66	CLK	O	Clock signal output for IC402
26	D.CLUB	O	"D.CLUB" indicator control signal	67	BIAS	O	Bias on signal output for IC304
27	HALL	O	"HALL" indicator control signal	68	DATA	O	Data output for IC402
28	STADIUM	O	"STADIUM" indicator control signal	69	POWER	O	Power control signal output
29	ROCK	O	"ROCK" indicator control signal	70	SPK	O	Speaker relay control signal output
30	POPS	O	"POPS" indicator control signal	71,72	V.DO,UP	O	Master volume up /down signal output
31	CLASSIC	O	"CLASSIC" indicator control signal	73	S.MUTE	O	Source mute control signal output
32	FLAT	O	Flat control signal for sound mode indicator	74	HP IN	I	Headphone in signal input
33,34	BFI,BRI	O	Forward / reverse indicator control signal for B deck	75	AD VCC	-	Power supply terminal
35	REC I	O	Recording indicator control signal	76~80	IN1~5	I	Operation switch signal input

■ LC7218 (IC121) : PLL Synthesizer

1. The main function descriptions

- (1) It makes the local oscillation frequency by the control data from IC804.
- (2) Decode the control signal and transmit the signal for receiving conditions.
- (3) For the best tuning, count the internal-frequency and transmit the data to IC804.

2. Terminal Layout

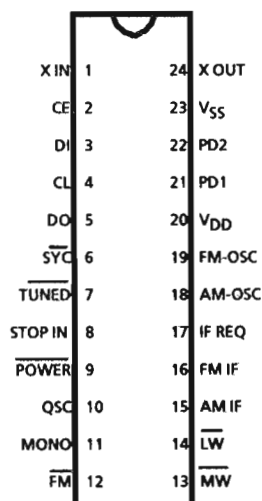

3. Block Diagram

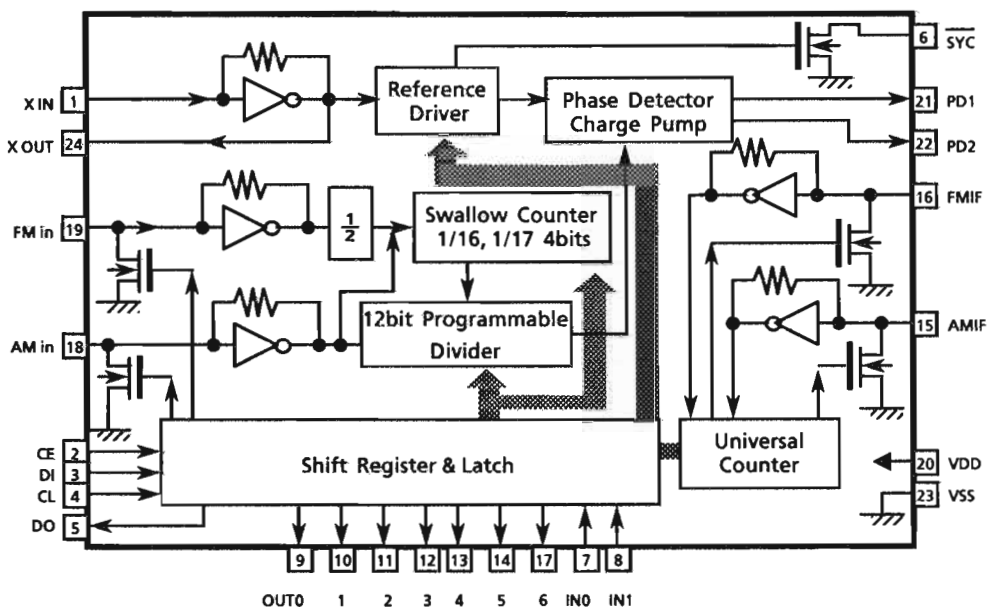

4. Pin Functions

Pin No.	Symbol	I/O	Function
1,24	X in, X out	I/O	Crystal oscillator (7.2MHz).
2	CE	I	Fix the chip enable to "H" when inputting (DI) and outputting (DO) the serial data.
3	DI	I	Receive the control data from the controller (IC804).
4	CL	I	This clock is used to synchronize data when transmitting the data of DI and DO.
5	DO	O	Transmit the data from LC7218 to the controller which is synchronized with CL.
6	SYC	—	Not used.
7	TUNED	I	Receive the tuned signal from IC102 (LA1836).
8	STOP IN	—	Connected to GND
9	POWER	—	Not used.
10	QSC	—	Not used.
11	MONO	O	It is "H" on FM-monaural, "L" on FM-Stereo.
12	FM	O	It is "L" on FM mode.
13	MW	O	It is "L" on MW mode.
14	LW	O	It is "L" on LW mode.
15	AM-IF	I	Universal counter input for AM-IF from IC102 (LA1836).
16	FM-IF	I	Universal counter input for FM-IF from IC102(LA1836).
17	IF REQ	O	Output the "IF-signal request" to IC102 when the pin-7 (tuned in) goes to "H".
18	AM OSC	I	Input the local oscillator signal of AM.
19	FM OSC	I	Input the local oscillator signal of FM.
20	V _{DD}	—	This is a terminal of power supply.
21	PD1	O	PLL charge pump output : When the local oscillator signal frequency is higher than the reference frequency high level signals will output. When it is lower than the reference frequency, low level signals will output. When it is same as reference frequency signals, it will be floating.
22	PD2	—	Not used.
23	V _{SS}	—	Connected to GND

■ LA1836M (IC102) : FM / AM IF Amp. & Detector

1. Terminal Layout

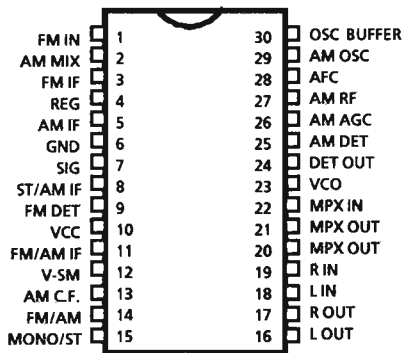

2. Pin Functions

Pin No.	Symbol	I/O	Function
1	FM IN	I	This is an input terminal of FM IF Signal.
2	AM MIX	O	This is an output terminal for AM mixer.
3	FM IF	I	Bypass of FM IF
4	REG	—	Register value between pin4 and pin28 desides the frequency width of the input signal.
5	AM IF	I	Input of AM IF Signal.
6	GND	—	This is the device ground terminal.
7	SIG	O	When the set is tunning ,this terminal becomes "L".
8	ST/AM IF	O	Stereo indicator output. Stereo : "L", Mono : "H"
9	FM DET	—	FM detect transformer.
10	VCC	—	This is the power supply terminal.
11	FM/AM IF	O	When the signal of IF REQ of IC121(LC7218) appear, the signal of FM/AM IF output.
12	VSM	O	S Meter output and adjust AM SD sensitivity.
13	AM C.F.	I	This is a terminal of AM ceramic filter.
14	FM/AM	I	Change over the FM / AM input. "H" : FM, "L" : AM
15	MONO/ST	O	Stereo : "H", Mono : "L"
16	L OUT	O	Left channel signal output.
17	R OUT	O	Right channel signal output
18	L IN	I	Input terminal of the Left channel post AMP.
19	R IN	I	Input terminal of the Right channel post AMP.
20	MPX L OUT	O	Mpx Left channel signal output.
21	MPX R OUT	O	Mpx Right channel signal output.
22	MPX IN	I	Mpx input terminal.
23	VCO	I	Voltage controlled oscillator terminal.
24	DET OUT	O	AM/FM detection output.
25	AM DET	—	AM low cut adjustment.
26	AM AGC	I	This is an AGC voltage input terminal for AM.
27	AM RF	I	This is an input terminal for AM RF signal.
28	AFC	—	This is an output terminal of voltage for FM-AFC.
29	AM OSC	—	This is a terminal of AM Local oscillation circuit.
30	OSC BUFFER	O	AM Local oscillation Signal output.

3. Block Diagram

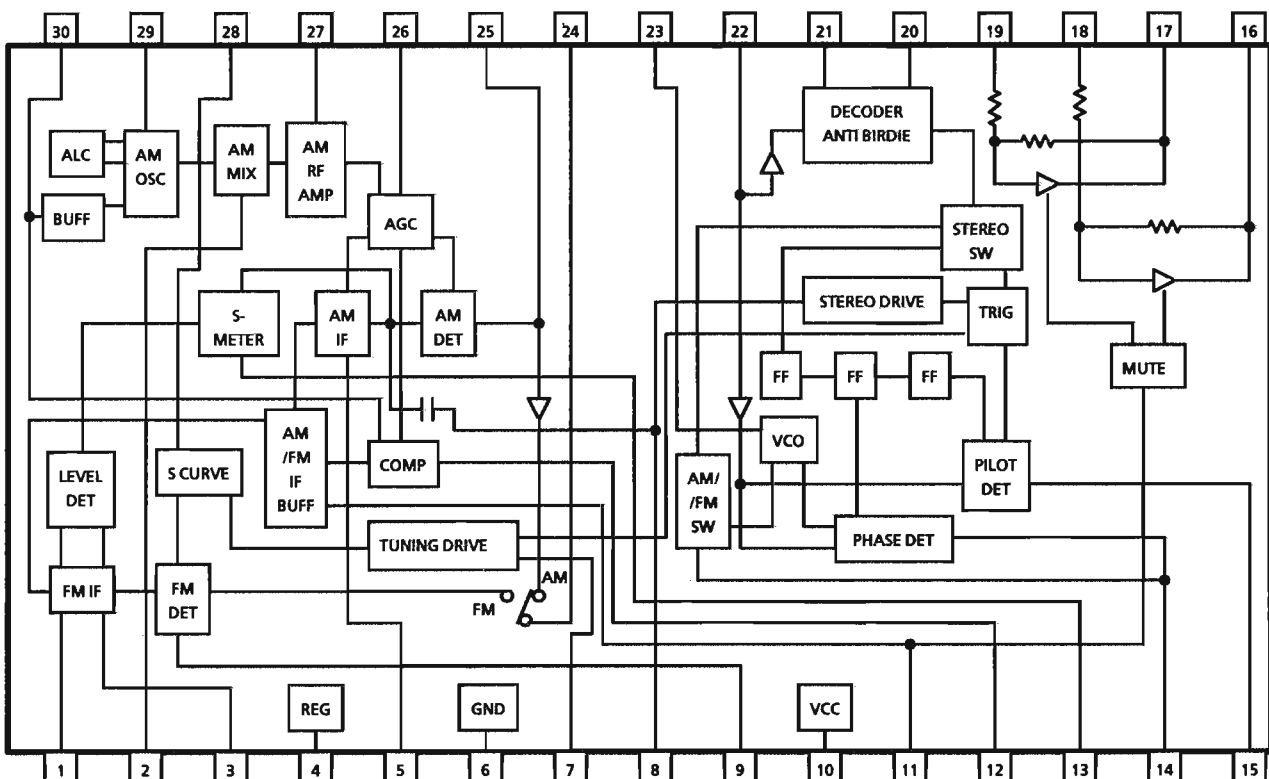

■ TA9284AF (IC998) : 1 CHIP PROCESSOR (1 BIT DAC)

Block Diagram

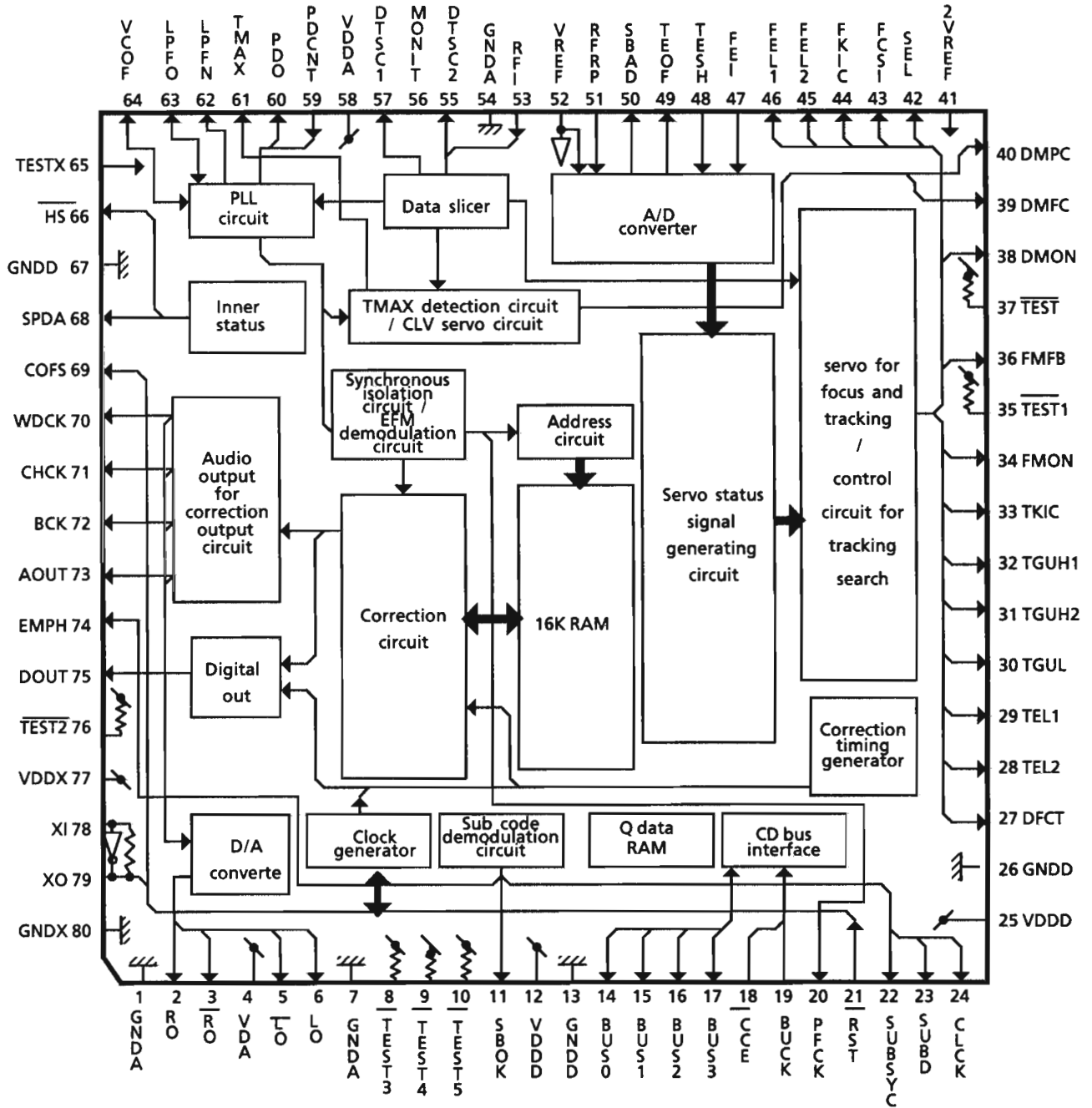

CA-C330

■ UPD65612GC-088 (IC801) : CD Changer Controller

1. Terminal Layout

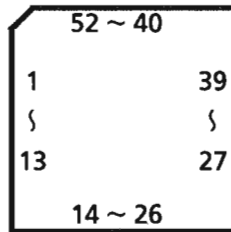

2. Pin Functions

Pin No.	Symbol	I/O	Function	Pin No.	Symbol	I/O	Function
1	EXTRA	I	Input terminal of the Disc case assy UP/DOWN RST.SW	27	C25OUT	--	Not used
2	CHPS	I	Input terminal of the changer HPS	28	C25IN	--	Not used
3	--	--	Not used	29	OS2I	--	Oscillation terminal
4	DOORPS	I	LOAD/UNLOAD Pals input	30	OS2	--	Oscillation terminal
5	OPEN	I	Input terminal of the CD Tray open	31	OS1	--	Oscillation terminal
6	CLOSE	I	Input terminal of the CD Tray close	32	OS1I	--	Oscillation terminal
7	DG	--	DGITAL GND	33	DG	--	DGITAL GND
8	TOP	I	Input terminal of the CD mecha. up	34	VCC	--	Power supply terminal
9	BOTTM	I	Input terminal of the CD mecha. down	35	RST	I	Reset signal input
10	DISCPS	I	Input terminal of the Disc NO. pals	36	CHREQ	O	Output the "mecha. data request" to IC804
11	ERROR	I	Input terminal of the Disc error	37	DATA	I	Control,Status data I/O for IC804
12	SCK	--	Connection to the ground	38	STCH	I	Strobe signal input from IC804
13	SELECT	--	Connection to the ground	39	CKS	I	Clock input from IC804
14	NC	--	Not used	40	NC	--	Not used
15	IN1	--	Connection to the ground	41	CHANGE 2	O	Plunger control signal
16	IN2	--	Connection to the ground	42	LED1	O	Indicator control signal
17	IN3	--	Connection to the ground	43	LED2	O	Indicator control signal
18	IN4	--	Connection to the ground	44	LED3	O	Indicator control signal
19	IN5	--	Connection to the ground	45	LED4	O	Indicator control signal
20	IN6	--	Connection to the ground	46	LED5	O	Indicator control signal
21	LMF	O	L motor control signal (foward)	47	LED6	O	Indicator control signal
22	LMR	O	L motor control signal (reverse)	48	NC	--	Not used
23	UDMUP	O	U/D motor control signal (up)	49	NC	--	Not used
24	UDNDW	O	U/D motor control signal (down)	50	NC	--	Not used
25	NC	--	Not used	51	NC	--	Not used
26	NC	--	Not used	52	NC	--	Not used

■ TA8191F (IC501) : Focus Tracking Servo LSI

1. Description

- RF amp, Focus error amp, and Tracking error amp
- Focus and Tracking servo amp
- Phase compensation amp and LPF amp

2. Terminal Layout

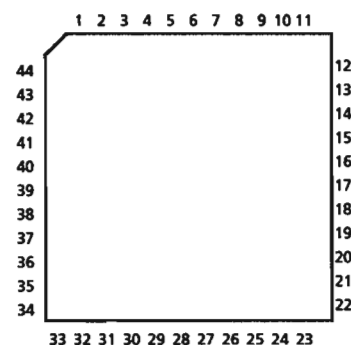

3. Pin Functions

Pin No.	Symbol	I/O	Function	Pin No.	Symbol	I/O	Function
1	TPO	O	Sub beam I-V amp (TP AMP) output	23	VCC	--	+ 5V
2	TPI	I	Sub beam I-V amp (TP AMP) input	24	DMEP	I	Disc motor amp (DM AMP) positive phase input
3	TNI	I	Sub beam I-V amp (TN AMP) input	25	DMEN	I	Disc motor amp (DM AMP) negative phase input
4	FNI	I	Main beam I-V amp (FN AMP) input	26	DMEO	O	Disc motor amp (DM AMP) output
5	FPI	I	Main beam I-V amp (FP AMP) input	27	DMPO	O	Disc motor driving amp (DM AMP) output
6	LDO	O	Laser diode amp (LD AMP) output	28	PVR	I	Driving amp reference voltage input
7	MDI	I	Monitor photo amp (MD AMP) input	29	FMPO	O	Feed motor driving amp (FMP AMP) output
8	RFN	I	RF amp (RF AMP) negative phase input	30	FMEO	O	Feed motor amp (FM AMP) output
9	RFO	O	RF amp (RF AMP) output	31	FMEP	I	Feed motor amp (FM AMP) negative phase input
10	RFI	I	RF ripple signal generating circuit	32	TS2O	I	Feed motor amp (FM AMP) positive phase input
11	VREF	O	Reference voltage supply (+ 2.1V) output	33	FAPO	O	Focus actuator driving amp (FAP AMP) output
12	RFRP	O	RF ripple signal output	34	2VRO	O	2VREF amp (2VREF AMP) output
13	SBAD	O	Defects detection signal output	35	2VVRP	I	2VREF amp (2VREF AMP) positive phase input
14	FEB	I	Focus error balance adjusting input	36	2VRN	I	2VREF amp (2VREF AMP) negative phase input
15	FEO	O	Focus error amp (FE AMP) output	37	TS2O	O	Tracking servo amp (TS2 AMP) output
16	SEL	I	Analog switch control signal input	38	TS2N	I	Tracking servo amp (TS2 AMP) negative phase input
17	VEE	--	GND	39	TS2P	I	Tracking servo amp (TS2 AMP) positive phase input
18	FSN	I	Focus output amp (FS AMP) negative phase input	40	TS1O	O	Tracking servo amp (TS1 AMP) output
19	FSO	O	Focus output amp (FS AMP) output	41	TS1N	I	Tracking servo amp (TS1 AMP) negative phase input
20	COSC	O	Focus search signal generating capacitor connecting	42	TS1P	I	Tracking servo amp (TS1 AMP) positive phase input
21	OSCI	I	Focus search signal generating built-in current source control input	43	TSO	O	Tracking output amp (TS AMP) output
22	GND	--	GND	44	TSN	I	Tracking output amp (TS AMP) negative phase input

CA-C330

■ BA8221N (IC353) : ALC (Auto Level Controller)

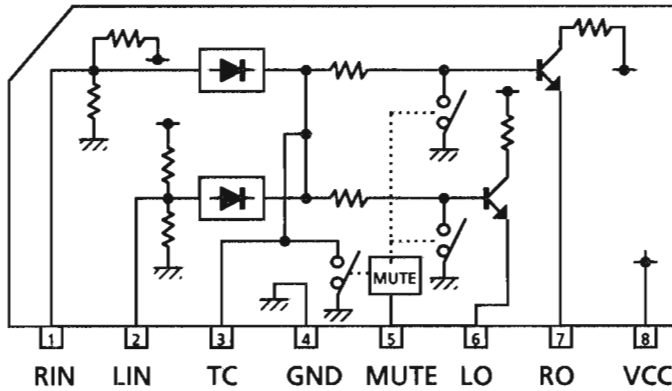

■ LB1639-CV (IC404) : Motor Driver

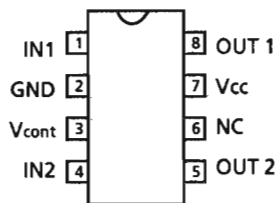

IN 1	IN 2	OUT 1	OUT 2	MOTOR
H	L	H	L	clockwise
L	H	L	H	counter - clockwise
H	H	OFF	OFF	waiting
L	L	OFF	OFF	waiting

■ BA15218N or XRA15218N (IC805,604) : Dual OP Amp. VC4580L (IC502,515) VC4580LD (IC503)

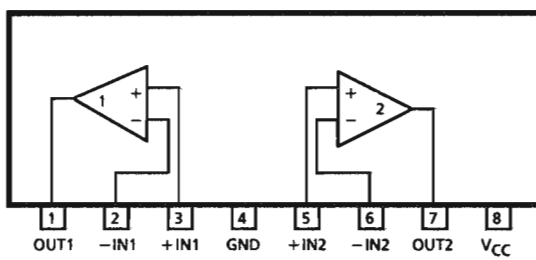

■ BA7725S (IC751) :Echo circuit (For U,UT,US)

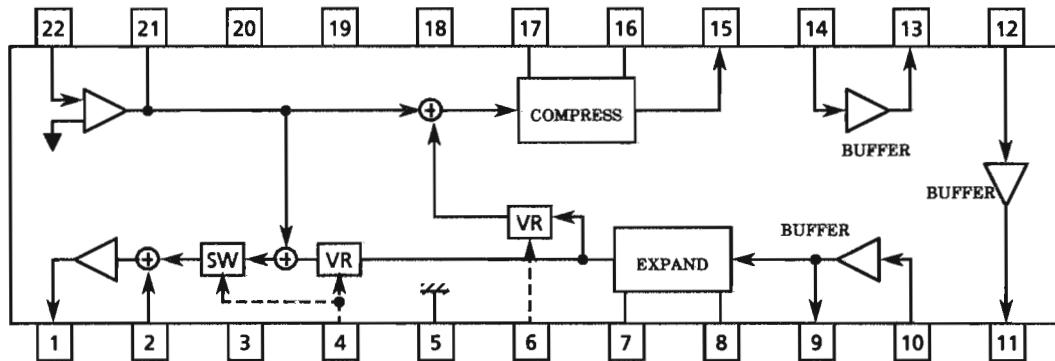

Terminal Description

Pin No.	Symbol	Function
1	LINE OUT	Line output
2	LINE IN	Line input
3	NC	Not used
4	ECHO LEV CTRL	Determines echo level. The echo circuit is off when 1 volt is added. The echo level varies according to the voltage from 2 volts to 9 volts.
5	GND	Analog GND
6	LOOP GAIN CTRL	Loop gain control terminal. The gain varies according to the voltage from 2 volts to 9 volts.
7	EXP DET	Detection terminal for expand circuit
8	EXP DET CT	Determines the attack and recovery time of expand circuit
9	EXP BF OUT	Buffer output (Expand circuit side)
10	EXP BF IN	Buffer input (Expand circuit side)
11	DLY BF OUT	Delay buffer output
12	DLY BF IN	Delay buffer input
13	CMP BF OUT	Buffer output (Compress circuit side)
14	CMP BF IN	Buffer input (Compress circuit side)
15	CMP OUT	Compress circuit output
16	CMP DET CT	Determines the attack and recovery time of compress circuit
17	CMP DET	Detection terminal for compress circuit
18	RIPPLE FITER	A capacitor is connected for ripple elimination filter
19	VCC	Power supply
20	NC	Not used
21	MIC AMP OUT	Mic amp output
22	MIC AMP IN	Mic amp input

CA-C330

■ BU9251S (IC652) : Delay Circuit (For U,UT,US)

Block Diagram

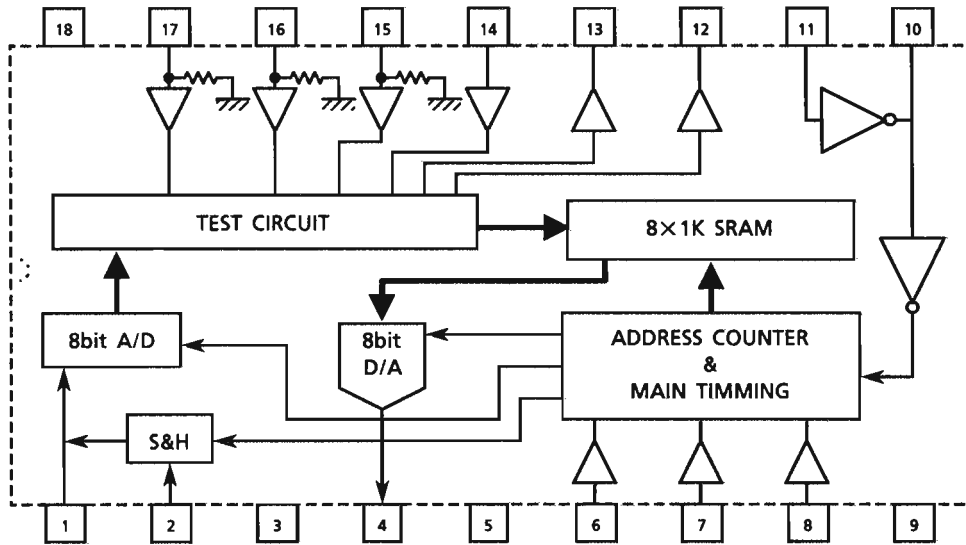

Description

Pin No	Symbol	Function	Pin No	Symbol	Function
1	S&H	A capacitor is connected for sample & hold	10	OSC0	Oscillation terminal
2	AIN	Analog input	11	OSC1	Oscillation terminal
3	GND	GND	12	TDO1	Not used
4	AOUT	Analog output	13	TDO0	Not used
5	VDD	Power supply	14	TDIN	Not used
6	DCNT0	Pull up (+5V)	15	TST2	Not used
7	DCNT1	Pull up (+5V)	16	TST1	Not used
8	DCNT2	Pull up (+5V)	17	TST0	Not used
9	GND	GND	18	VCC	Power supply

■ HA12171NT (IC304) : DOLBY NR&RECORD EQUALIZER

1. Outline

- Dolby B type NR
- Reoed equalizer
- Interval detection

2. Terminal Layout

GND	1	○	56	GND
AIN(R)	2		55	AIN(L)
BIN(R)	3		54	BIN(L)
ABO(R)	4		53	ABO(L)
CIN(R)	5		52	CIN(L)
RIN(R)	6		51	RIN(L)
BIAS	7		50	RIP
PBOUT(R)	8		49	PBOUT(L)
DET(R)	9		48	DET(L)
RECOUT(R)	10		47	RECOUT(L)
EQIN(R)	11		46	EQIN(L)
BOOST(R)	12		45	BOOST(L)
EQOUT(R)	13		44	EQOUT(L)
PB A/B	14		43	BIAS(N)
A 120/70	15		42	BIAS(C)
PAS/DOL	16		41	BIAS(M)
NORM/HIGH	17		40	BIASOUT
B 120/70	18		39	VREF
CROM/METAL	19		38	NOI
BIAS ON/OFF	20		37	FFI
RM ON/OFF	21		36	MS-GND
NR ON/OFF	22		35	MAOUT
MS GAIN R/S	23		34	MSIN
REC/PB	24		33	MSDET
LM ON/OFF	25		32	MS-VCC
IREF	26		31	MSOUT
GPCAL	27		30	D-GND
RECCAL	28		29	VCC

3. Terminal Description

Pin No	Symbol	I/O	Function	Pin No	Symbol	I/O	Function
1	GND	--	Ground	29	VCC	--	Power supply
2	AIN(R)	I	Deck A playback input (Rch)	30	D-GND	--	Digital GND
3	BIN(R)	I	Deck B playback input (Rch)	31	MSOUT	O	Blank scanning signal output
4	ABO(R)	O	Playback buffer out (Rch)	32	MS-VCC	--	Power supply
5	CIN(R)	I	70 μ Buffer input (Rch)	33	MSDET	I	Time constant setting for music scan
6	RIN(R)	I	Recording input (Rch)	34	MSIN	I	Input for music scan
7	BIAS	I	Connected to GND	35	MAOUT	O	Buffer AMP for music scan
8	PBOUT(R)	O	Playback output (Rch)	36	MS-GND	--	GND
9	DET (R)	I	NR time constant (Rch)	37	FFI	I	Feedback input for MS(FF,REW)
10	RECOUT(R)	O	Recording output (Rch)	38	NOI	I	Feedback input for MS
11	EQIN(R)	I	Input for recording equalizer (Rch)	39	VREF	--	Reference for music scan
12	BOOST(R)	I	Time constant for low boost (Rch)	40	BIASOUT	O	Recording bias control
13	EQOUT(R)	O	Equalizer output (Rch)	41	BIAS(M)	I	Bias current input for metal tape
14	PB A/B	I	Deck A/B select	42	BIAS(C)	I	Bias current input for CrO2 tape
15	A 120/70	I	Deck A playback EQ select	43	BIAS(N)	I	Bias current input for normal tape
16	PASS/DOL	I	Dolby signal path select (Through/pass)	44	EQOUT(L)	O	Equalizer output (Lch)
17	NORM/HIGH	I	Dubbing mode select	45	BOOST(L)	I	Time constant for low boost (Lch)
18	B 120/70	I	Deck B playback EQ select	46	EQIN(L)	I	Input for recording equalizer (Lch)
19	CROM/METAL	I	Tape select	47	RECOUT(L)	O	/Recording output (Lch)
20	BIAS ON/OFF	I	Bias ON/OFF control	48	DET(L)	I	NR time constant (Lch)
21	RM ON/OFF	I	Recording mute ON/OFF control	49	PBOUT(L)	O	Playback output (Lch)
22	NR ON/OFF	I	NR ON/OFF control	50	RIP	I	Ripple filter
23	MS GAIN R/S	I	Gain for music scan control	51	RIN(L)	I	Recording input (Lch)
24	REC/PB	I	Recording/Playback control	52	CIN(L)	--	70 μ buffer input (Lch)
25	LM ON/OFF	I	Playback mute ON/OFF control	53	ABO(L)	O	Playback buffer out (Lch)
26	IREF	I	Reference current input	54	BIN(L)	I	Deck B playback input (Lch)
27	GPCAL	I	GP calibration	55	AIN(L)	I	Deck A playback input (Lch)
28	RECCAL	I	Recording gain calibration	56	GND	--	GND

Internal Connections of FL Display

■ ELU0001-201 : (FL800)

1. Grid Layout

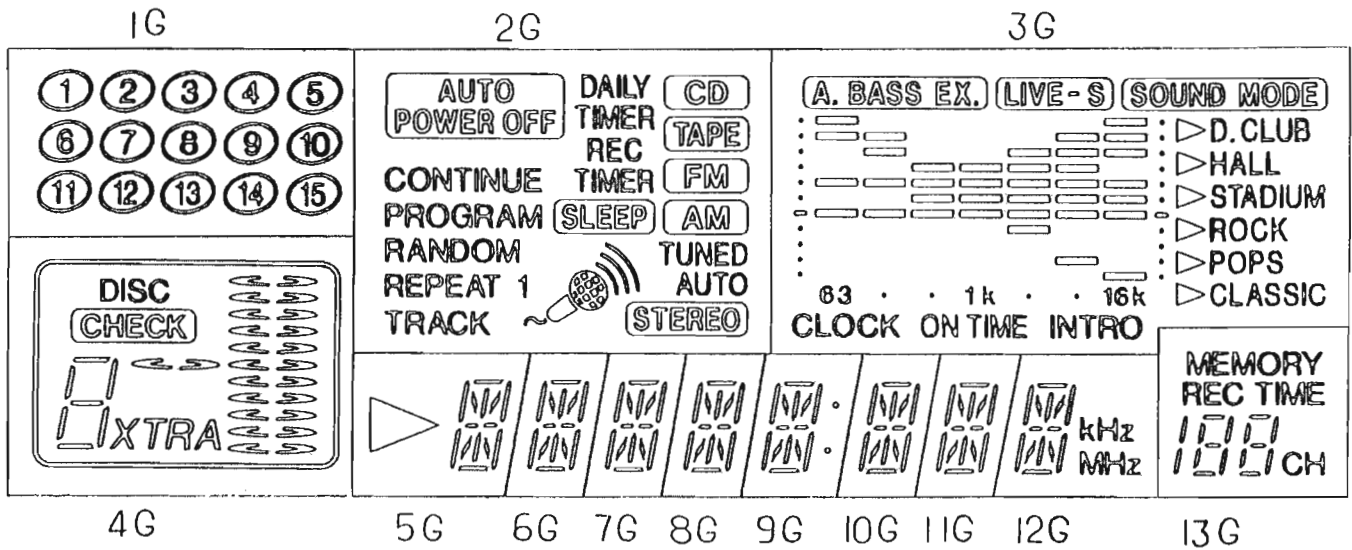

2. Pin Connections

LOWER

TERMINAL NO.	1	2	3	4	5	6	7	8	9	10	11	12	13	14	15	16
ELECTRODE	F1	F1	F1	NP	P S1	P S2	P S3	P S4	P S5	P S6	P S7	P S8	P S9	P S10	P S11	P S12
TERMINAL NO.		17	18	19	20	21	22	23	24	25	26	27	28	29	30	31
ELECTRODE		P S13	P S14	P S15	P S16	NP	P S17	P S18	P S19	P S20	P S21	P S22	NP	F2	F2	F2

UPPER

TERMINAL NO.	32	33	34	35	36	37	38	39	40	41	42	43	44	45	46	47
ELECTRODE	F2	F2	F2	NP	P S23	P S24	P S25	P S26	P S27	P S28	P S29	P S30	P S31	P S32	P S33	P S34
TERMINAL NO.		48	49	50	51	52	53	54	55	56	57	58	59	60	61	62
ELECTRODE		P S35	1G	2G	3G	4G	5G	6G	7G	8G	9G	NP	NP	F1	F1	F1

(Notes) F: Filament G: Grid P: Anode NP: No Pin

(3) Anode Designation

	1G	2G	3G	4G	5G	6-8G	9G	10, 11G	12G	13G
S1	⑮	TRACK	CLOCK	S1	▶		s		kHz	MEMORY
S2	⑭	STEREO	ON TIME	S2	a	a	a	a	a	REC TIME
S3	⑬	S3	INTORO	S3	b	b	b	b	b	1a
S4	⑫	REPEAT	CLASSIC	S4	j	j	j	j	j	1b
S5	⑪	1	POPS	S5	k	k	k	k	k	1f
S6	⑩	S6	ROCK	S6	h	h	h	h	h	1g
S7	⑨	S7	STADIUM	S7	f	f	f	f	f	1c
S8	⑧	S8	HALL	S8	g	g	g	g	g	1e
S9	⑦	AUTO	D. CLUB	S9	m	m	m	m	m	1d
S10	⑥	TUNED	SOUND MODE	S10	e	e	e	e	e	CH
S11	⑤	SLEEP	LIVE-S	S11	n	n	n	n	n	2a
S12	④	RANDOM	A BASS EX	S12	r	r	r	r	r	2b
S13	③	AM	S13	S13	p	p	p	p	p	2f
S14	②	PROGRAM		S14	c	c	c	c	c	2g
S15	①	CONTINUE		XTRA	d	d	d	d	d	2c
S16		REC TIMER			d		t		MHz	2e
S17		FM			e					2d
S18		TAPE			c					3a, 3b
S19		AUTO POWER OFF			g					
S20		DAILY TIMER			f					
S21		CD			b					
S22					a					
S23				CHECK						
S24				S24						
T1			▶ (D. CLUB) ,T1							
T2			▶ (HALL) ,T2							
T3			▶ (STUDIUM) ,T3							
T4			▶ (ROCK) ,T4							
T5			▶ (POPS) ,T5							
T6			▶ (CLASSIC) ,T6							
T7			T7							
T8			T8							
T9			T9							
T10			T10							

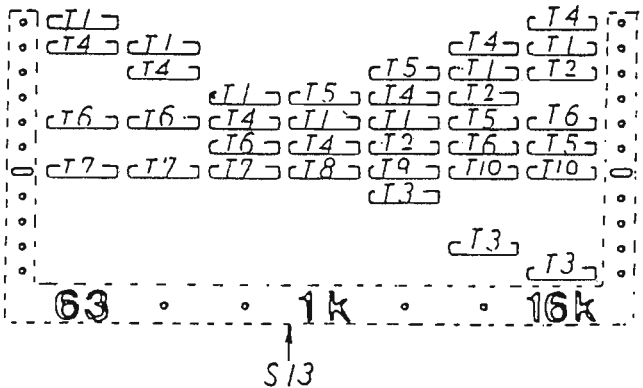
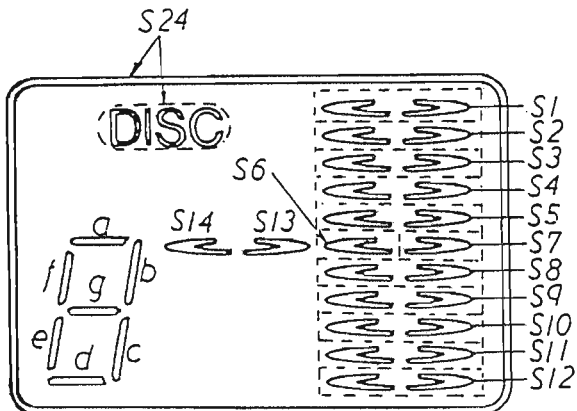
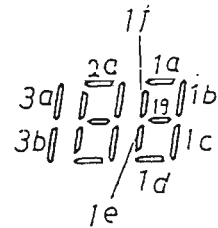
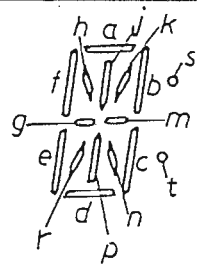
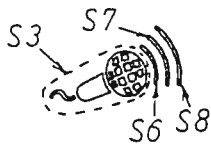

— MEMO —

Disassembly Procedures

(1) Top cover removal

1. Take off 6 screws **A** on the rear side and 2 screws **A** on both sides of the cover.
2. Remove the cover.

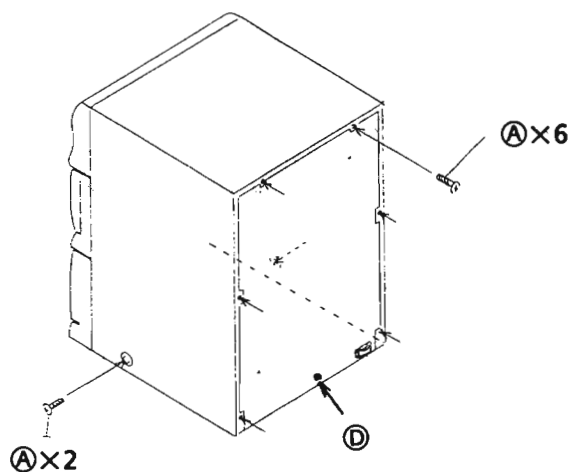

Fig. 1

(2) Front panel and Cassette mecha ass'y removal

1. Remove the top cover.
2. Remove the main volume knob and remove the NUT for the volumeshaft.
3. Take off 2 screws **B** and remove the Main P.C.B. from the cassette P.C.B.'s connector.
4. Drawing out the Disc base ass'y and remove the Tray Fitting.
5. Remove 8 flat wires from each connector.
6. Take off 2 screws **C** on the bottom side.

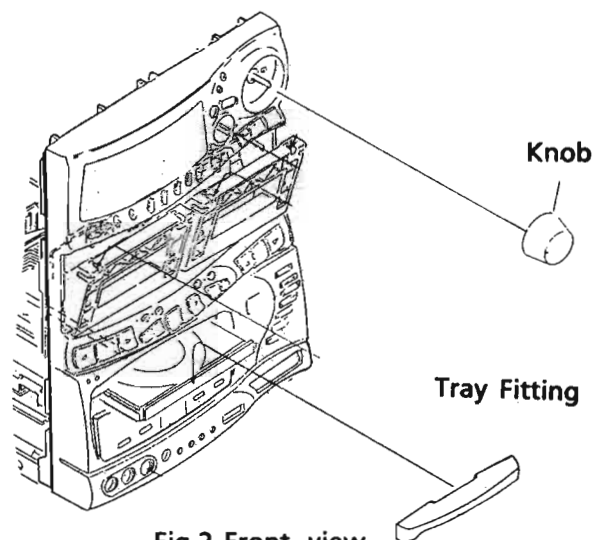

Fig. 2 Front view

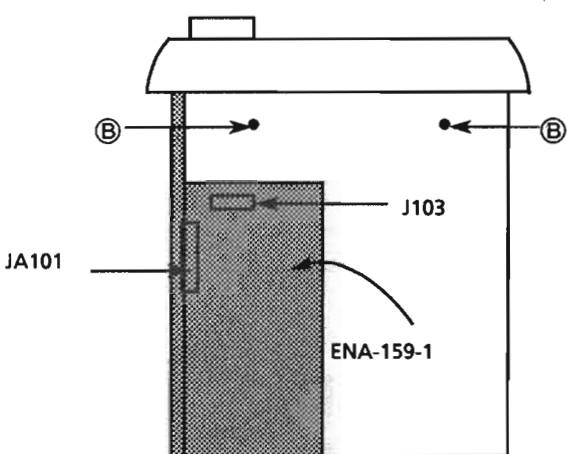

Fig. 3 Top view

Front

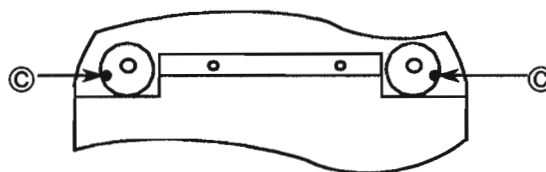

Fig. 4 Bottom view

(3) Rear panel removal (including power trans and power amp. P.C.B. and tuner P.C.B. and main P.C.B.)

1. Remove the top cover.
2. Remove the main volume knob and remove the NUT for the volumeshaft.
3. Take off 8 flat wires from each connector.
4. Take off 2 screws **B** and remove the Main P.C.B. from the cassette P.C.B.'s connector.
5. Take off a screw **D** and remove the rear panel.

A .. SD5G3006M **B** ... SPST2604Z **C** ... SBST3006Z **D** ... E73273-003

(4) CD Changer mechanism assembly removal

1. Remove the front panel assembly and rear panel assembly.
2. Take off 4 screws ③ securing the CD changer mechanism assembly.
3. Remove the CD changer mechanism assembly.

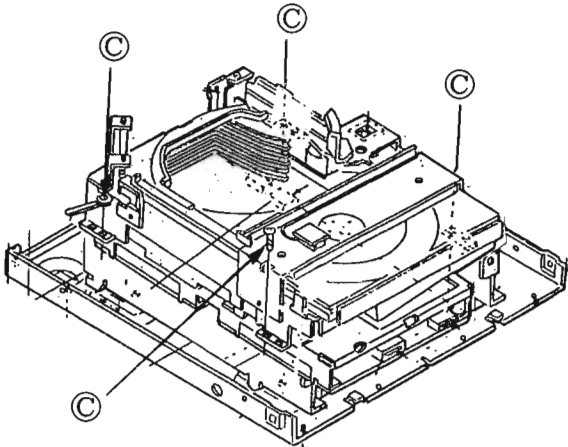

Fig. 5

(5) Disc base assembly removal

1. Remove the CD changer mechanism assembly.
2. Take off 2 screws ⑤ securing the clamper base assembly.
3. Turn the gear G4 manually in the direction of arrow as shown in Fig.6, and lower the CD mechanism assembly.
4. Remove a screw ⑥ securing the disc base bracket visible from notched window of the disc base assembly. (Refer to Fig.7)
5. Draw out the disc base assembly to the position the base is hooked.
6. After turning over the CD changer mechanism assembly, move the point ⑥ engaging the cover plate A (S) and disc base assembly in the direction of arrow and disengage the above plate and assembly. (Refer to Fig.8)
7. While lifting the tip of the disc base assembly, move the blue guide stopper slide switch in the direction of arrow, and remove the switch from the disc base assembly. (Refer to Fig.9)
8. Draw out the disc base assembly further toward the front side until it is hooked by the guide.
9. When the guide stopper switch and guide have been removed by lifting the tip of disc base assembly, then the disc base assembly will be dismantled.

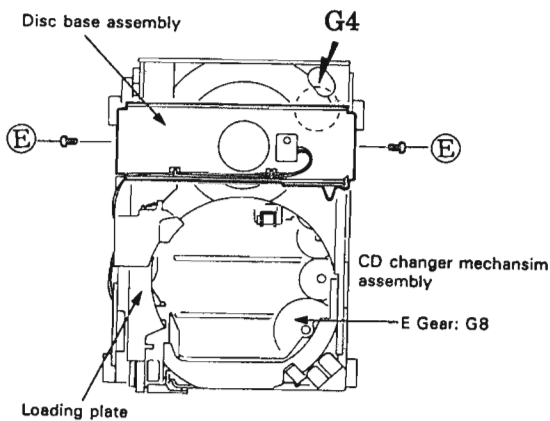

Fig. 6

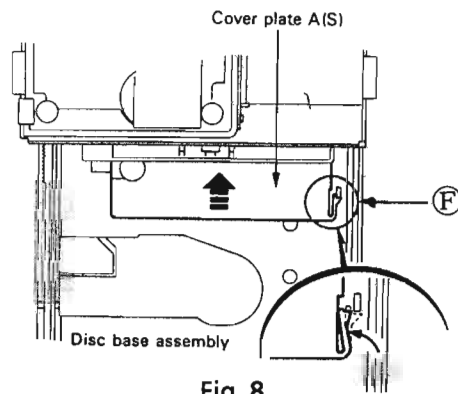

Fig. 8

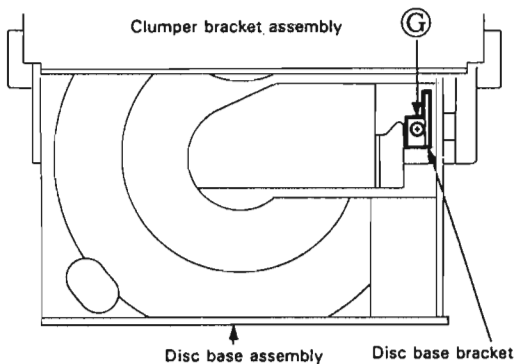

Fig. 7

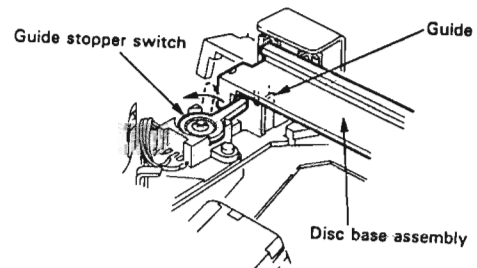

Fig. 9

③ .. SBST3006Z ⑤ ... 9P0420041T ⑥ ... 9P0420041T

(6) CD mechanism removal

1. Remove the CD changer mechanism assembly.
(Refer to Item (4) of "CD changer mechanism assembly removal")
2. After turning over the CD changer mechanism assembly, from the CD changer mechanism assembly, remove the 2 screws \textcircled{H} securing the P.C. board holder bracket. (Refer to Fig.10)
3. From the CD changer mechanism assembly, remove the 2 screws \textcircled{I} securing the CD mechanism. (Refer to Fig.11)

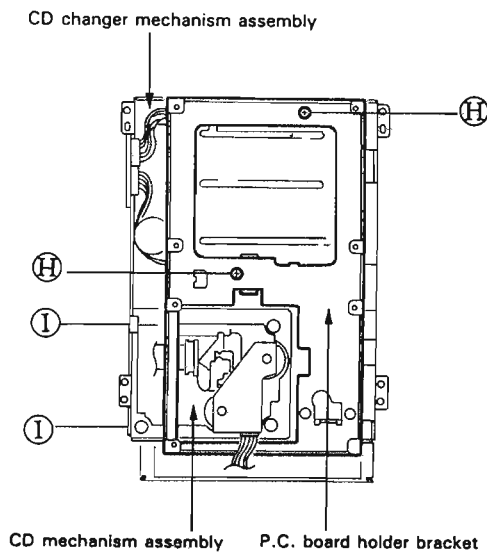

Fig. 10

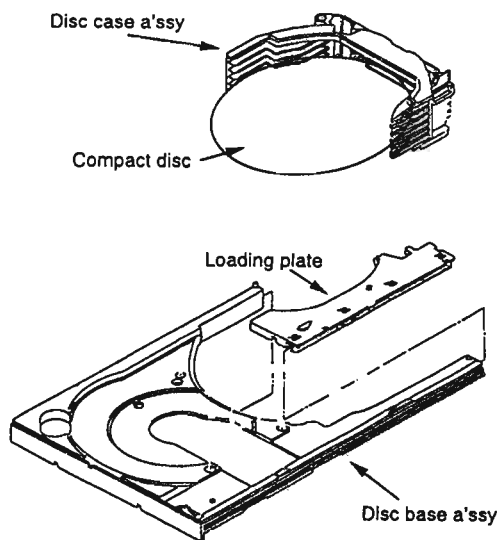

Fig. 12

■ Forced ejection method of Compact Disc

1. Remove the CD changer mechanism assembly.
(Refer to Item (4) of "CD changer mechanism assembly removal")
2. Compact disc ejection method.
 - 2-1. Method of ejecting the compact disc on the disc base ass'y. (Refer to Fig.6)
 - (1) Turn the gear G4 clockwise and lower the CD mechanism.
 - (2) When the loading plate is located at the rear most position, move the plate to the front panel side (At this time, the compact disc will be set on the disc base ass'y by the loading plate).
 - (3) By moving the disc base ass'y to the front panel side, take out the compact disc.
 - 2-2. Method of ejecting the compact disc left on the disc case ass'y (Refer to Fig.12).
 - (1) Move the loading plate to the rear most position.
 - (2) Turn the E gear G8 (Refer to Fig.6) counterclockwise, and move up the disc case ass'y into which any compact disc has been loaded.
 - (3) While turning the E gear G8, align the first compact disc (the lowermost compact disc on the disc case ass'y) to its loading position to the loading plate.
 - (4) After the loading plate onto which the first compact disc is loaded has been moved to the front panel side, pull out the disc base ass'y from the front panel side and take out the compact disc.
 - (5) Eject the second through sixth compact discs as well similarly according to the procedures in Items (1) through (4).
Whenever the second and subsequent discs are to be ejected, however, align the compact disc to be ejected to the height of the loading plate.

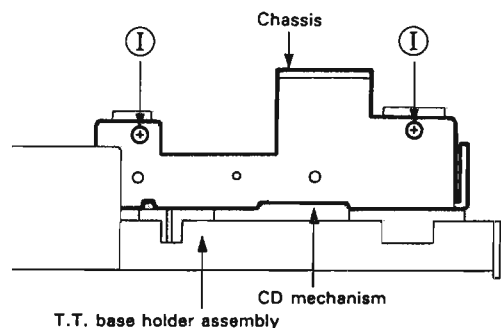

Fig. 11

\textcircled{H} .. SBST3006Z \textcircled{I} ... 9P0720061T

(7) Cassette mechanism with the PCB (ENJ-083) removal

1. Remove the (1) and (2).
2. Open the cassette door.
3. Remove the 4 screws (K) and the 4 screws (J).
4. Remove the Cassette mechanism.

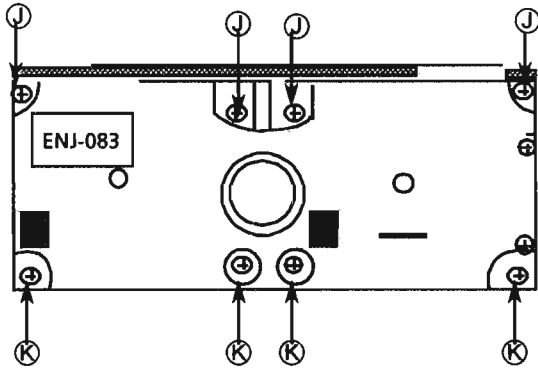

Fig. 13 Front panel Rear view

(8) Cassette lid removal

1. Open the cassette door.
2. Remove the Cassette lid slide up ward.

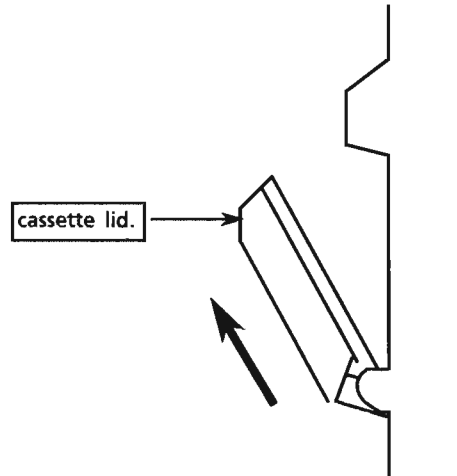

Fig 14 Side view

(9) Front SW PCB(ENH-263-2,3) removal

1. Remove the (1),(2),(4)and (5),(7),(10).
2. Remove the Cassette mechanism assembly.
3. Remove the 6 screws (E)holding the braket .
4. Remove the 14 screws (E)holding the SW PCB.
5. Remove the SW PCB .

(10) Cassette door lock plate removal

1. Remove the (1),(2)and (5),(9).
2. Remove the 2screw (E)holding the door lock plate.
3. Remove the door lock plate.

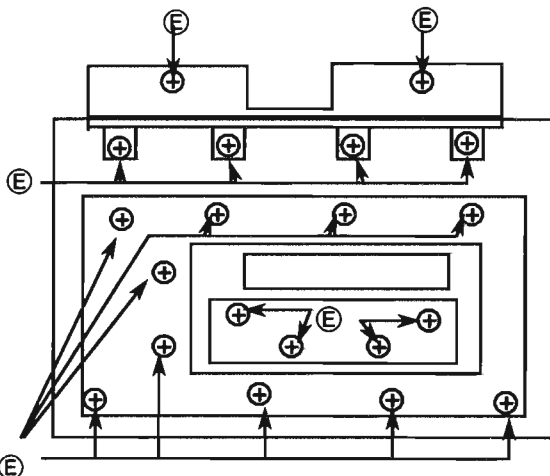

Fig 15 Front panel Rear view

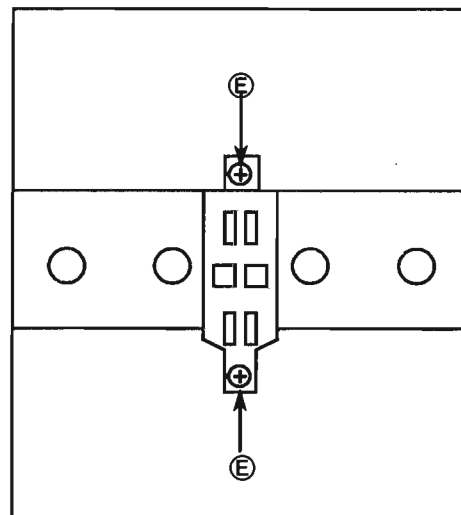

Fig 16 Front panel Rear view

(E) .. SDSF2608Z (F) ... SBSF3008Z (G) ... SBST3006Z

- (11) Damper removal
1. Remove the cassette mechanism.
 2. Remove the spring holding the cassette holder.
 3. Press the tab which secures the damper to remove the damper. (See the arrow shown in the figure below)

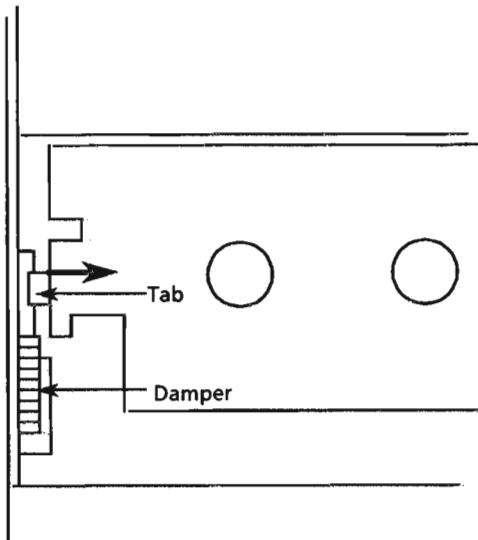

Fig 17 Door damper view

- (12) Cassette holder removal
1. Remove the Cassette mechanism assembly.
 2. Remove the spring holding the cassette holder.
 3. Remove Cassette holder .

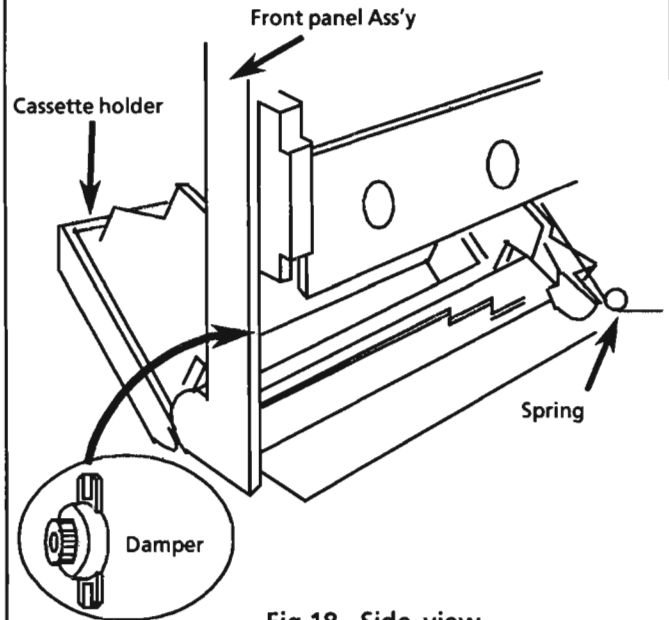

Fig 18 Side view

- (13) Capstan motor removal.
1. Remove the cassette mechanism.
 2. Remove the cassette deck control PCB.
 3. Remove the 6screws holding the bracket.
 4. Remove the capstan motor with the bracket.
 5. Remove the 2screws fixing the motor and the braket.

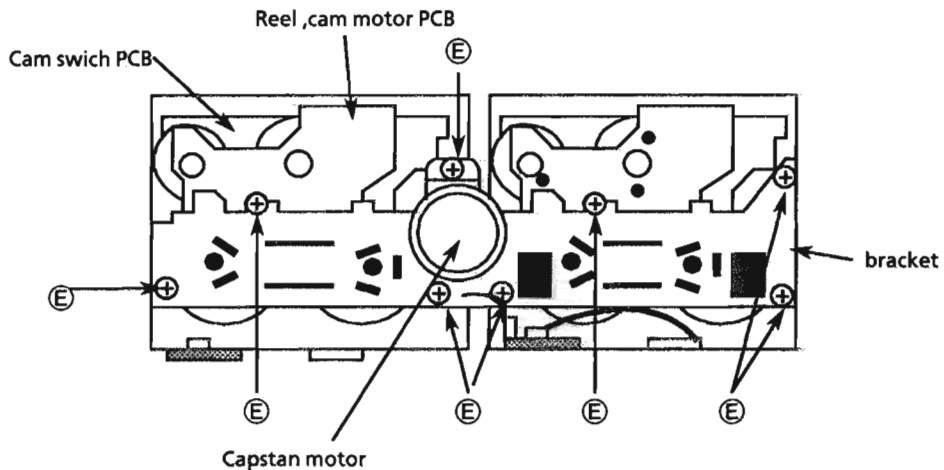

Fig 19 Cassette mechanism bottom view

(14) Head assembly

The direction of the head is changed with the head gear. When servicing, install the head gear according to the direction of the head.

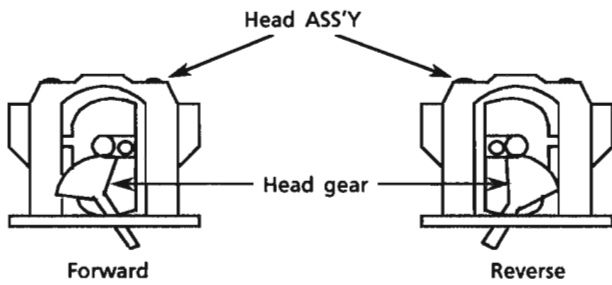

Fig20 Head ass'y side view

(15) Pinch roller arm assembly removal

1. Release the hook holding the pinch roller arm assembly to remove the assembly .

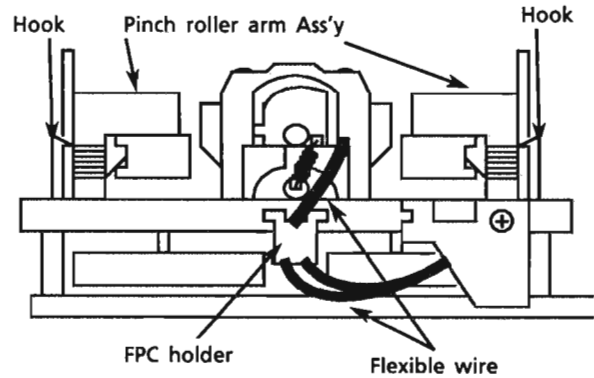

Fig21 Cassette mechanism side view

(16) Fly wheel removal

1. Remove the cassette mechanism assembly.
 2. Remove the cassette controller PCB.
 3. Remove the 8 screws (E) and the bracket
- * The oil on the capstan must be wiped out after re-assembling.

(17) Fly wheel assembly

1. Install the beltB of bossA ,next install the beltA as shown in fig 19 up side.
2. Assemble the d the bracket with the capstan motor.
3. Hang the beltB of the motor pulley using a tweezers and the like as shown in fig 19 down side .

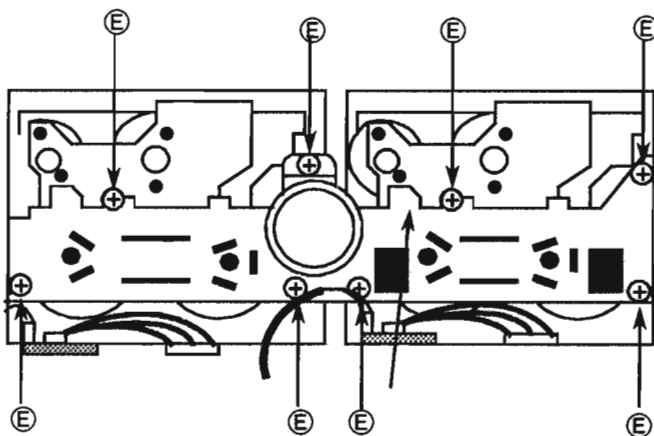

Fig 22 Cassette mechanism bottom view

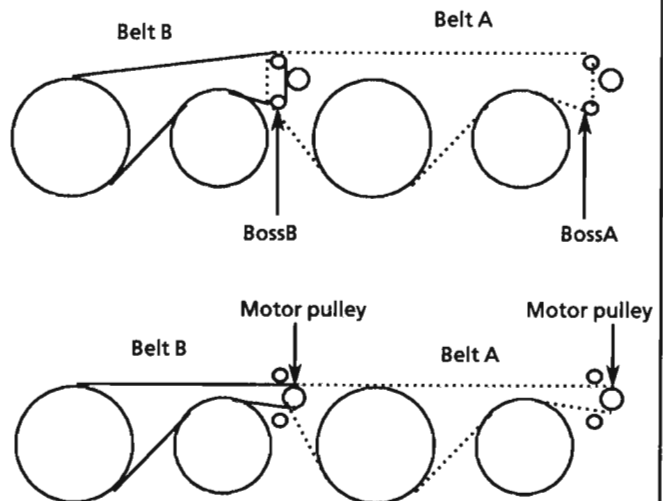

Fig 23 Fly wheel view

(A) .. SD5G3006M (B) ... E73273-003

(18) Reel and cam motor removal

1. Remove the cassette mechanism assembly.
2. Remove the cassette controller PCB.
3. Remove the (15).
4. Remove the 2screws① and 2screws②.
5. Unsolder the reel and cam motor PCB .
6. Remove the motor .

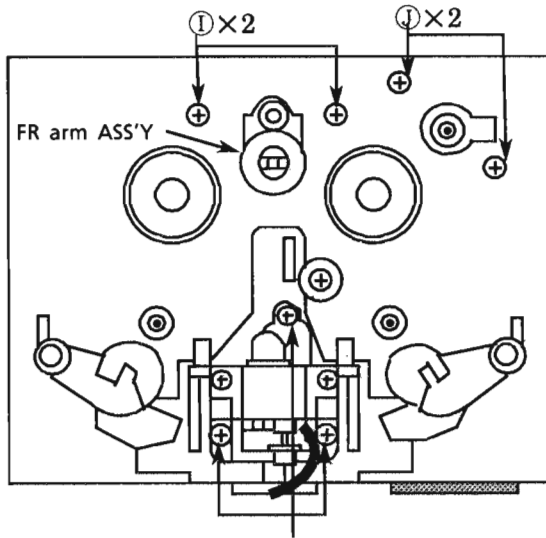

Fig 24 Cassette mecha Top view

(19) Cam SW PCB removal

1. Remove the (18).
 2. Remove the reel and cam motor PCB.
 3. Remove the screw and hooks fixing the PCB to remove the Cam SW .
- When assembling the cam switch ,install it so that the part ④ meets the part ⑤.

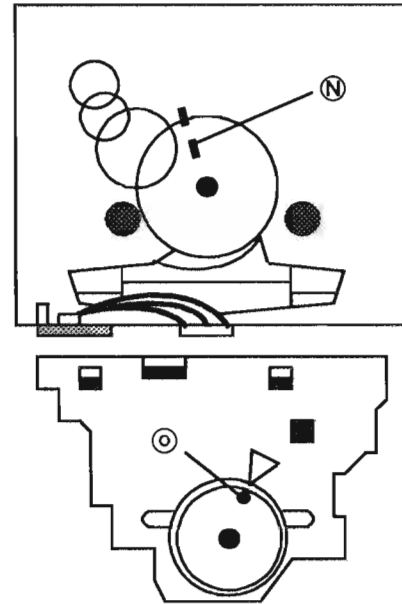

Fig 25 AMP PCB view

(20) Cassette control PCB(ENJ-083)removal.

1. Remove the (1)(2)and (5).
2. Disconnect the J303,J304.
3. Remove the 2screws ③holding the Cassette control PCB.
4. Remove the Cassette control PCB.

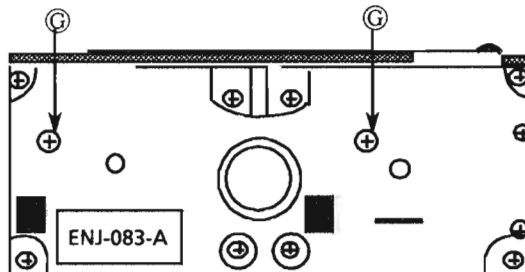

Fig 26 Cassette mechanism Bottom view

(21) Head assembly removal

1. Remove the cassette mechanism assembly.
2. Remove the FPC wire to the Cassette control PCB.
3. Remove the 3 screws ④ holding the Cassette control PCB.

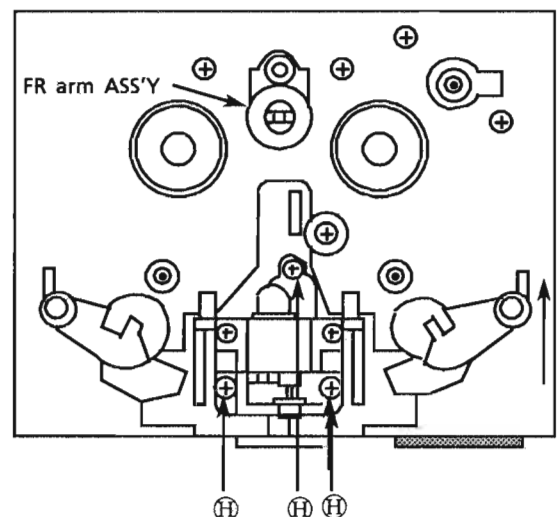

Fig 27 Front panel rear view

© .. SPST2604Z

④ ... SBST3006M

⑤ ... SDSF2608Z

Adjustment Procedures

■ Tuner section

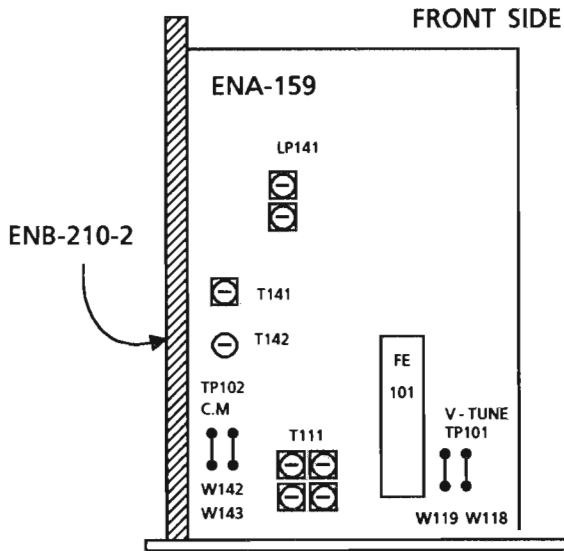

Clock Adjustment

1. After connecting W620 and W621 with some wire as shown in the figure below, connect the AC power cord into an AC outlet.
2. Confirm that the display is off and remove the wire.
3. Connect a frequency counter to W622 and W621.
4. Adjust TC801 so that the frequency becomes $50000 \pm 0.29\text{Hz}$.

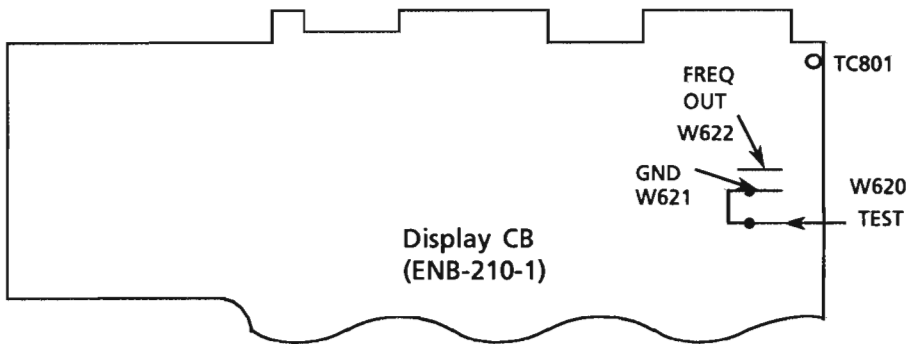

(1) Tuning voltage

Confirm the voltages at TP101 is within the standard values shown in the table below. If the voltages are not satisfied, replace T111 for MW and for LW or FE101 for FM.

FM Tuning voltage (Unit : V)

Area	Frequency	
	87.5MHz	108MHz
EXCPET EAST EUROPE	$1.6 \pm 0.5(V)$	7~10 (V)
EAST EUROPE	$1.6 \pm 0.5(V)$	7~11 (V)

AM Tuning voltage (Unit : V)

Area	Frequency (MW)							Frequency (LW)	
	522KHz	530KHz	531KHz	1600KHz	1602KHz	1629KHz	1710KHz	144kHz	353kHz
the U.K., Europe	1.0 > 0.5	—	—	—	—	7.5 < 8.5	—	0.7 <	5.5~9
U.S.A,Canada	—	1.0 > 0.5	—	—	—	—	7.5 < 8.5	—	—
Universal(Chanel Space 9kHz)	—	—	1.0 > 0.5	—	7.5 < 8.5	—	—	—	—
Universal(Chanel Space 10kHz)	—	1.0 > 0.5	—	7.5 < 8.5	—	—	—	—	—
Australia	1.0 > 0.5	—	—	—	—	7.5 < 8.5	—	—	—

(2) FM center meter

Receive a broadcast by using the function of 'AUTO STOP'.

Adjust T141 (detector coil) so that the voltage at TP102 becomes $0 \pm 1.5\text{mV}$.

Adjustment Procedures

■ CD section

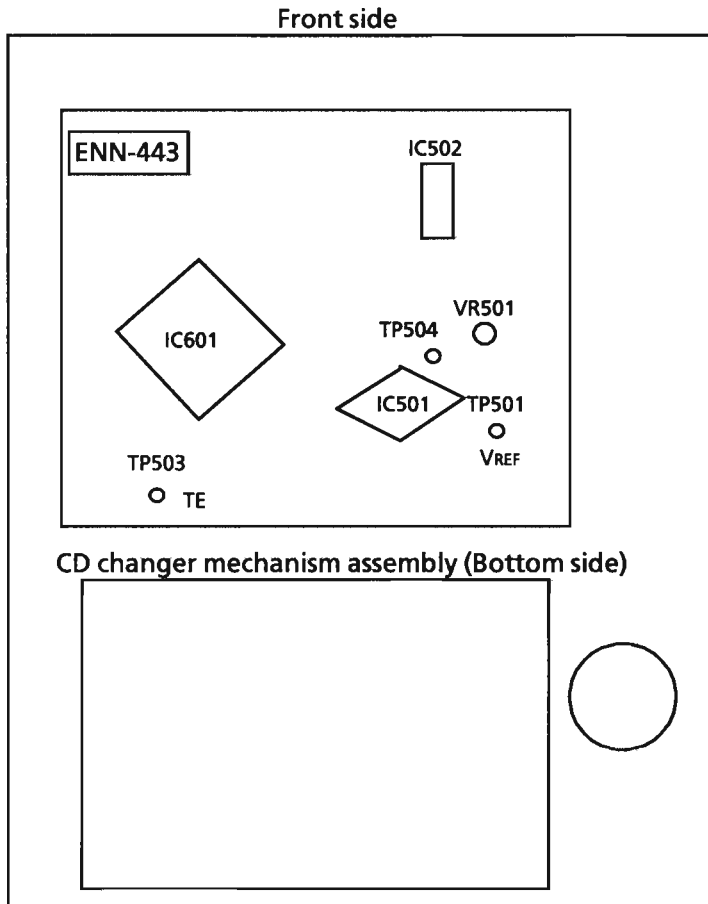

1. CD changer mechanism assembly removal.
2. Re-assembling front panel assembly (including cassette mechanism ass'y) and rear panel ass'y.
3. Connections all wires connection.
4. Adjusting Tracking offset adjustment.

Tracking offset adjustment

- 1) Measuring instruments : Oscilloscope, Normal disc
- 2) Adjusting procedure
 - (1) Connect an oscilloscope with TP503 (HOT side) and TP501 (EARTH side) on the CD servo (ENN-443) PC board.
 - (2) Play a disc.
 - (3) Short circuit between TP504 and TP501.
 - (4) Adjust VR501 for setting the DC level of the tracking error (off set) becomes 0.

Note : Adjust VR501 for setting the waveform becomes symmetrical around the 0 level.

Input to the oscilloscope should be DC coupling.

■ Deck section

1. Measuring instruments

Audio frequency signal generator (0dbS output at the 600 ohm output terminal from 50Hz to 20KHz)
 Electronic voltmeter
 Frequency counter
 Wow & Flutter meter
 Distortion Meter with band pass filter
 Attenuator (600 ohm impedance)
 A resistor with 600Ω

Tape No.	Frequency	Level (Wow & Fkutter)	Purpose
VTT-703L	10kHz	-10dBs	Head azimuth , Frequency Response
VTT-712	3000Hz	0dBs 0.025%WRMS	Tape Speed , Wow & Flutter
VTT-724	1kHz	-4dBs	Standard Level
TMT-6447	—	—	Blunk Skip
TMT-6247 , TMT-6237	—	—	Music Scan
TMT-7088S	—	—	Recording standard Normal : UR
AC-712	—	—	Recording standard METAL :MA
AC-513	—	—	Recording standard CrO ₂ :SA
TW-2111, TW-2121	—	—	Forward / reverse play torque measuring
TW-2231	—	—	Feed forward / rewind torque measuring
C-120 Tape	—	—	Confirming the tape running

2. Adjustment and repairing the mechanism

Item	Adjustment method	Standard value	Remarks
Head azimuth	<p>Deck A</p> <ol style="list-style-type: none"> 1. Connect an electronic voltmeter to the DOLBY TP (figure 3) to playback VTT-703L. 2. Adjust screw Ⓐ so that the indication of the voltmeter becomes maximum when PLAY (▶) is pressed. 3. Adjust screw Ⓑ so that the indication of the voltmeter becomes maximum when PLAY (◀) is pressed. <p>Deck B</p> <ol style="list-style-type: none"> 4. Adjust screw Ⓒ so that the indication of the voltmeter becomes maximum when PLAY (▶) is pressed. 5. Adjust screw Ⓓ so that the indication of the voltmeter becomes maximum when PLAY (◀) is pressed. 6. After making the adjustment, apply screw lock to prevent screws Ⓐ, Ⓑ, Ⓒ and Ⓓ coming loose. 	Maximum	<ol style="list-style-type: none"> 1. Refer to figure 1. 2. When the specified characteristic cannot be obtained because of head wear, excessive magnetization, etc., replace the head assembly and adjust the head azimuth. Also, perform the electric adjustment. 3. When there is the difference of more than 3 ~ 4 dB between left and right output levels, replace the head assembly to avoid complaints.
Playback torque	1. Measure the torque in the playback mode by the torque meter.	26 ~ 62 g-cm	When the standard torque cannot be obtained, replace the FR arm assembly or motor.
Fast forward torque	1. Measure the torque in the fast forward mode by the torque meter.	80 ~ 200 g-cm	When the standard torque cannot be obtained, replace the FR arm assembly or motor.
Rewind torque	1. Measure the torque in the rewind mode by the torque meter.	80 ~ 200 g-cm	When the standard torque cannot be obtained, replace the FR arm assembly or motor.
Wow & flutter	<ol style="list-style-type: none"> 1. Connect the wow & flutter meter to the DOLBY TP (figure 3) and play back VTT-712. 2. Its reading should be within 0.2% (WTD). 	Less than 0.2%	As a complaint may occur if the wow & flutter fluctuates by 0.1% even though it is allowed in the standard, repairing is required.

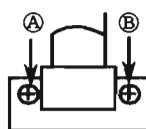

Deck A

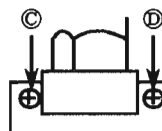

Deck B

Figure 1

3. Electrical Adjustments (Make the following adjustments after adjusting the head azimuth.)

In principle, the adjustments should be made in the following sequence.

Set the NR switch to OFF and the BEAT CUT switch to "1".

Adjustments marked with an asterisk (*) should always be made after the head is replaced

0dBs=0.775V.

Item	Adjustment Method	Adjustment Location	Standard Value	Remarks
Tape Speed	1. Connect a frequency counter to the DOLBY TP (figure 3) and play back VTT-712 . 2. Adjust the semi-fixed resistor VR948 on ENJ - 083 .	VR948	3,000 Hz ± 10Hz	Connect a wow & flutter meter with a built-in frequency counter to the speaker terminals.
Standard level (Playback Level)	1. Connect an electronic voltmeter to the DOLBY TP (figure 3) . Play back VTT-724 (1 kHz : -4dBs) to adjust the semi - fixed resistors.	Deck A L: VR311 R: VR312 Deck B L: VR333 R: VR334	488mV (-4dBs)	1) The playback level varies when the head is replaced so should be adjusted. Use an electronic voltmeter with an impedance of 100 kΩ or more.
Playback Frequency Response	1. Connect an electronic voltmeter to the DOLBY TP (figure 3) . 2. Play VTT-703L (10kHz : -10dBs) and adjust semi-fixed resistors to obtain the standard values.	Deck A L: VR303 R: VR304 Deck B L: VR323 R: VR324	245mV (-10dBs)	—
Recording Bias Frequency	1. Connect a frequency counter to the BIAS TP (figure 3) , and perform a recording to adjust bias frequency .	L331	100 kHz ± 5 kHz	Set the BEAT CUT SWITCH to "1" .
Record / Play Frequency Response (Bias current)	1. Supply 1kHz and 12.5kHz with 30mV signals to PHONO/AUX terminals respectively to record them. 2. Connect an electronic voltmeter to the DOLBY TP (figure 3) to confirm the recorded values . 3. If the values are not satisfied , adjust the semi-fixed resistors and record the signal again to confirm the recorded values.	L: VR355 R: VR356	0±2 dB with 1 kHz as the standard.	Refer to figure 2 below. 1) The recording and playback frequency response of a cassette deck are adjusted by adjusting the bias. 2) Perform the adjustment with normal tape and confirm that the values are within the range for metal tape.

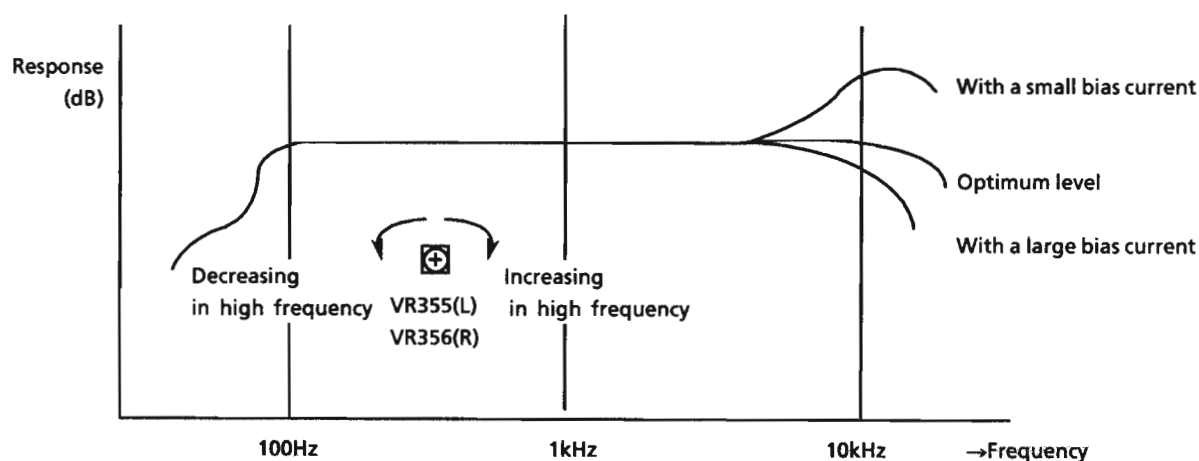

Figure 2

Item	Adjustment Method	Adjustment Location	Standard Value	Remarks
Record / Playback Sensitivity	<ol style="list-style-type: none"> 1. Input a 1kHz (300mV) signal to AUX terminal and record it with a normal tape. 2. Connect an electronic voltmeter to the DOLBY TP (figure 3) to confirm the values. 3. If the values are not satisfied , adjust the semi-fixed resistors and record the signal again to confirm the values. 	L : VR205 R : VR206	-5.5dBs (411mV)	Adjust with normal tape and make sure that the left / right level difference is 1.0dB or less
Recording / playback distortion	<ol style="list-style-type: none"> 1) Input a 1 kHz (300mV) to AUX terminal and record it. 2) Play it back and check the speaker out with a distortion meter to make sure it is within the criterion. 		less than 3% (Normal/ CrO ₂)	Perform after the record / play frequency response and recording /playback sencitivity adjustments.
Recording / playback S/N ratio	<ol style="list-style-type: none"> 1) Input a 1 kHz (300mV) signal to AUX terminal and record it. While recording, remove the input and record without the signal. 2) Connect a electronic voltmeter to the speaker terminals to measure the output levels. 3) Confirm that the output level ratio between the signals with a 1kHz and no signal is more than 40dB. 		more than 40 dB (Normal/ CrO ₂)	
Erase ratio check	<ol style="list-style-type: none"> 1. Record a music source using the Metal tape. 2. Rewind and erase the recorded section. 3. Comfirm nothing can be heard. 	—	—	—
Music Scan	<ol style="list-style-type: none"> 1. Make sure not to work the music scanning operation at the start of tape wind. 2. Make sure to work the music scanning operation at the end of tape wind. 	—	—	—

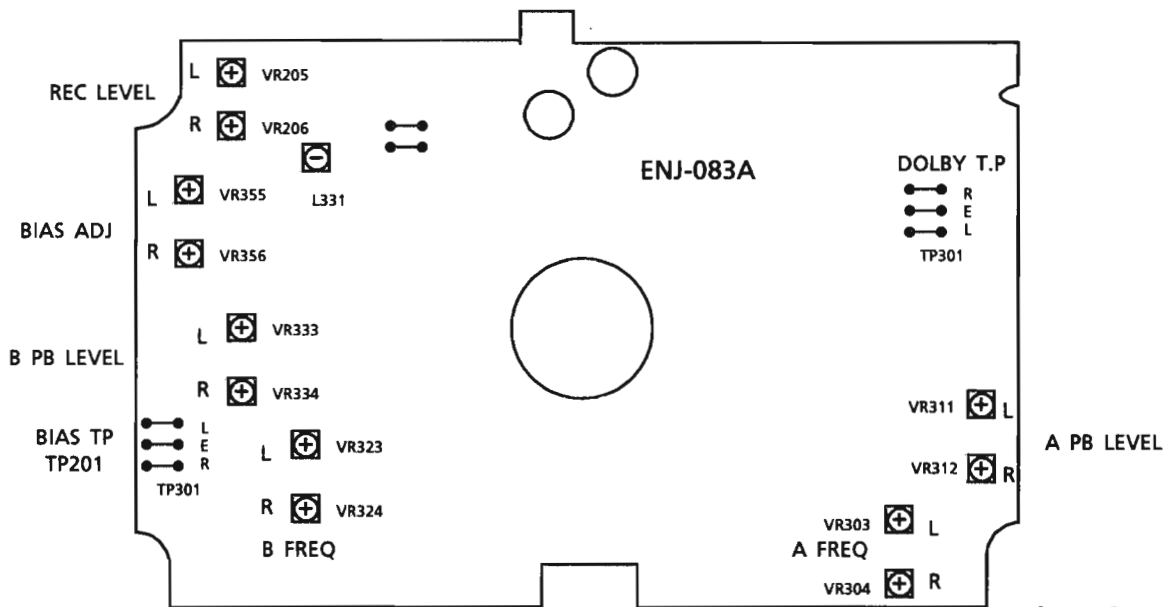

Figure 3

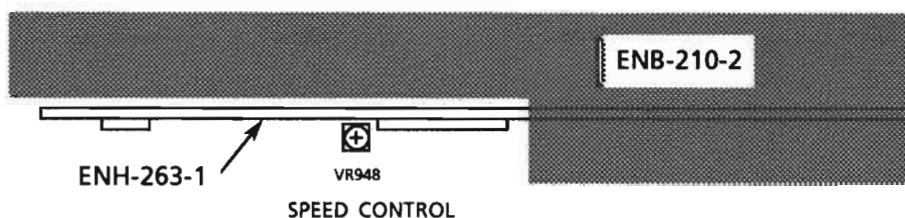
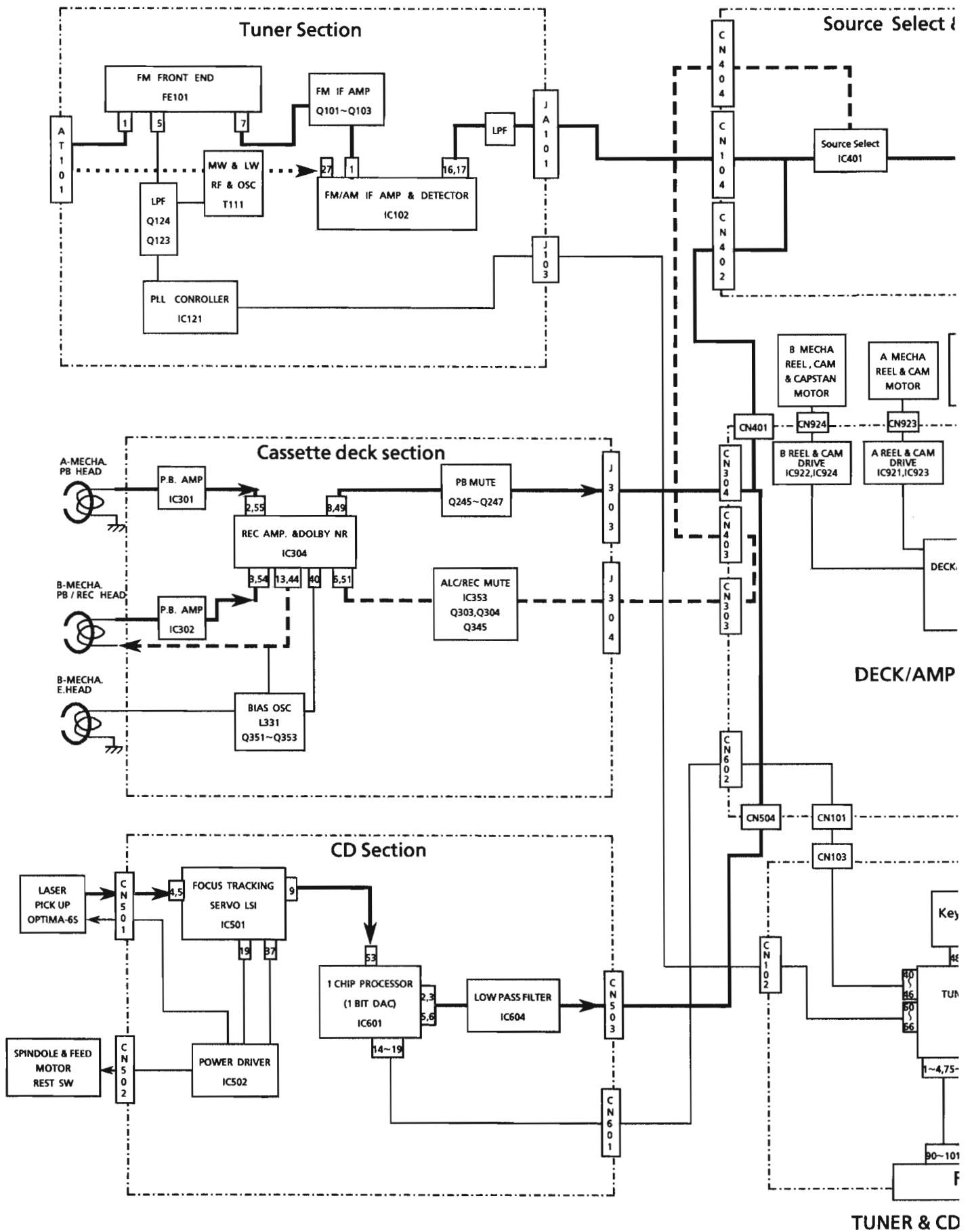
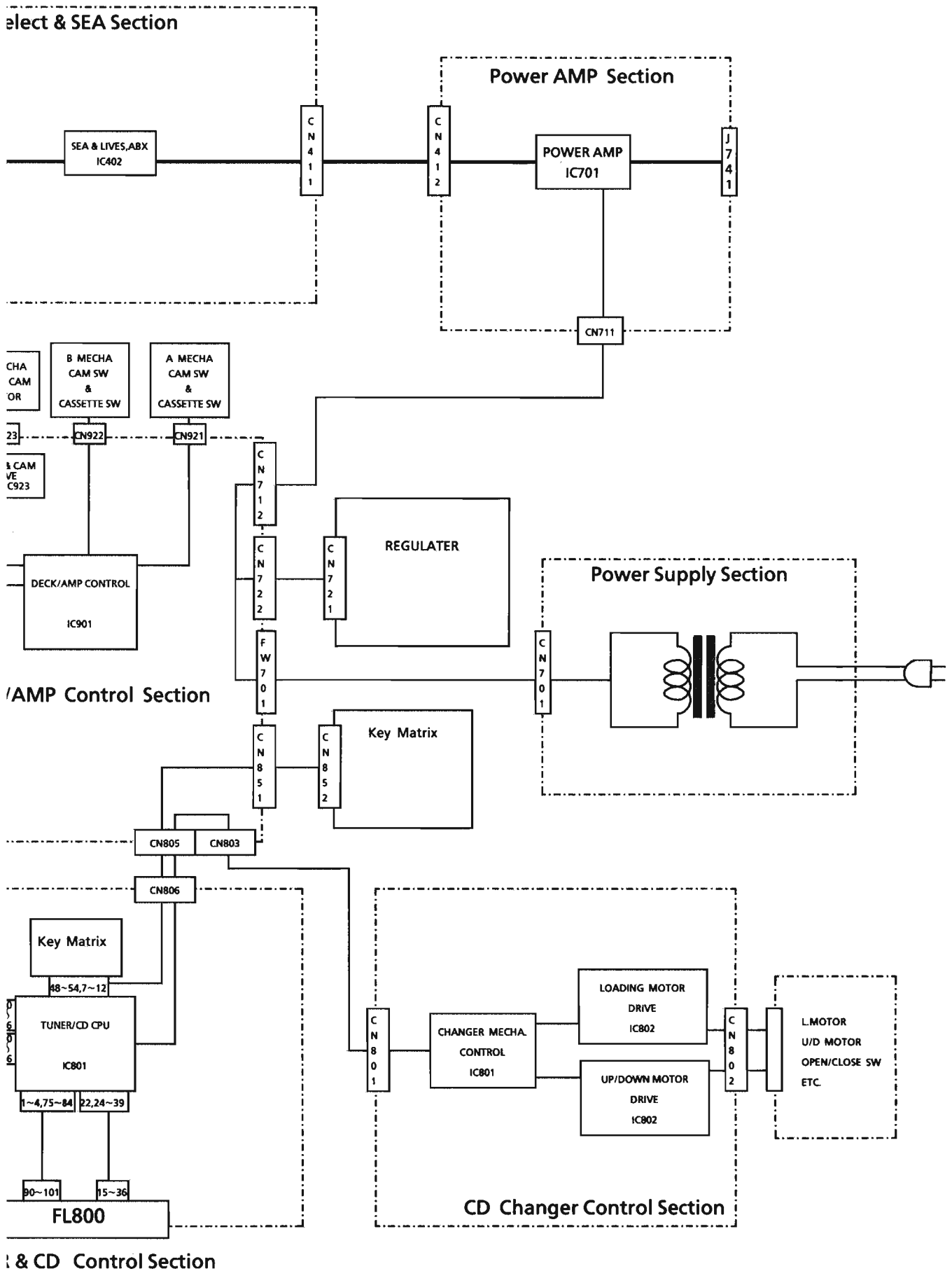

Figure 4

FRONT

Block Diagrams





Connection Diagram

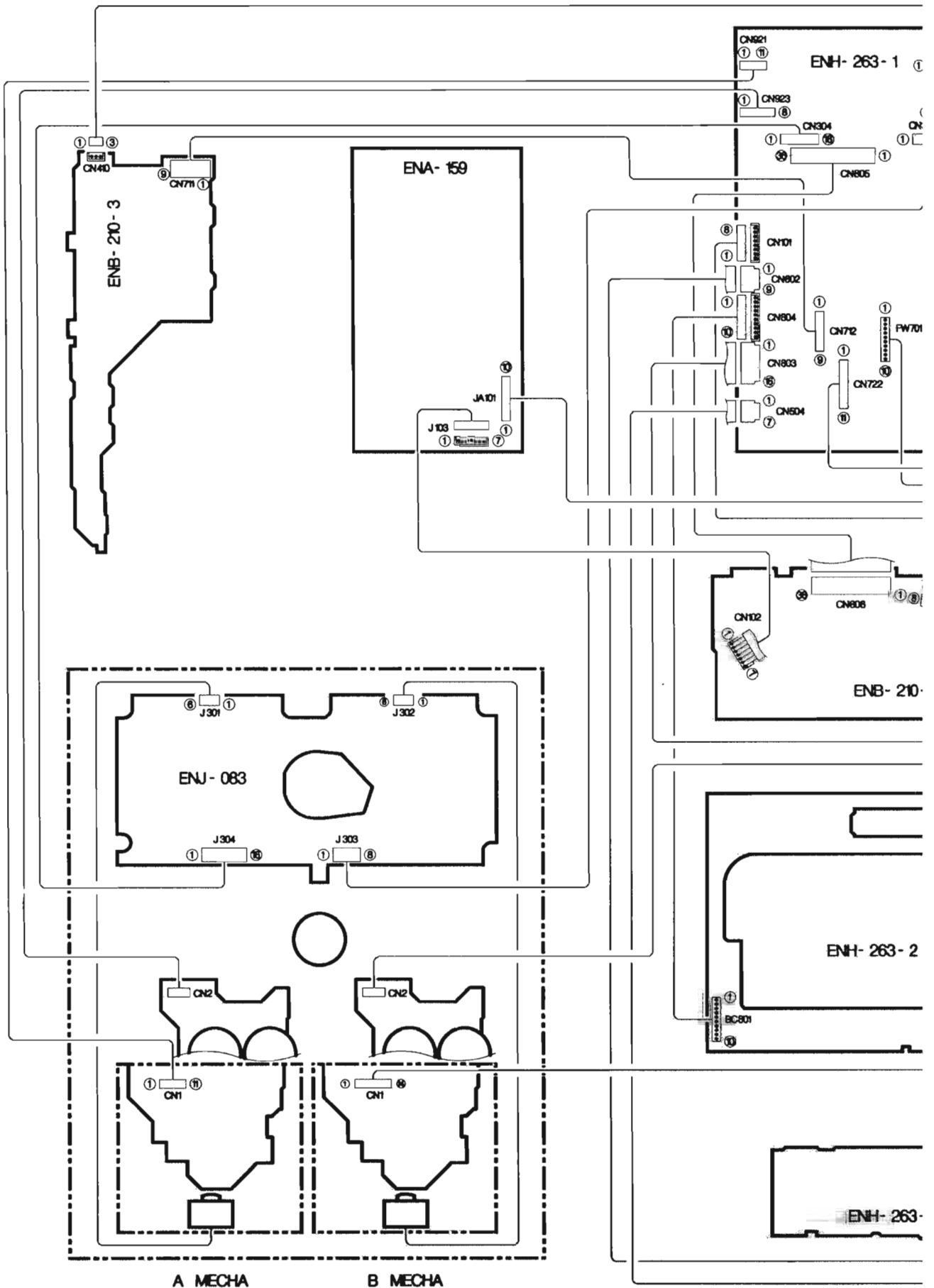

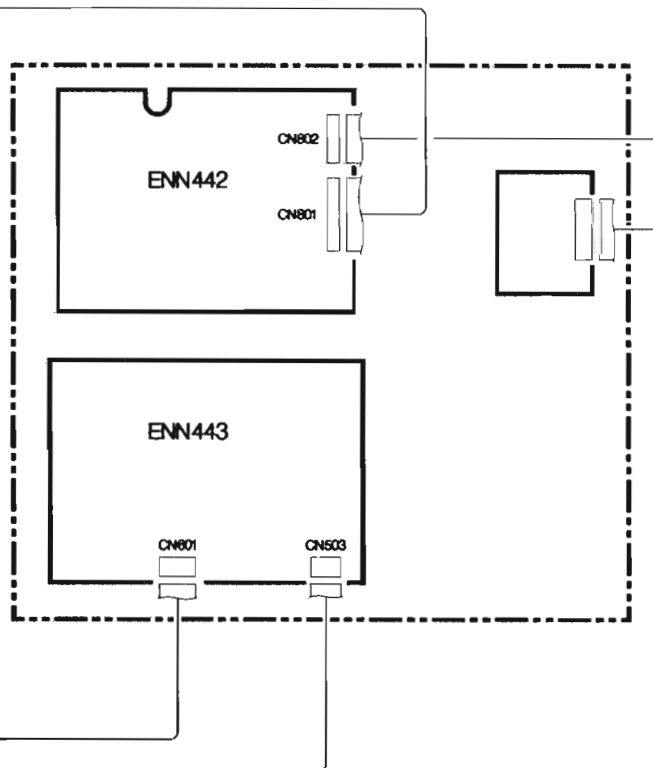
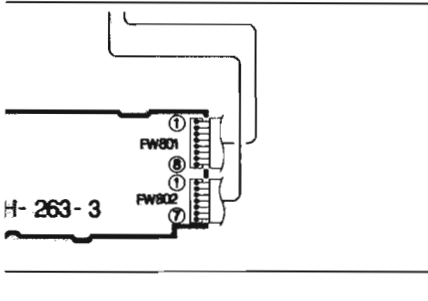
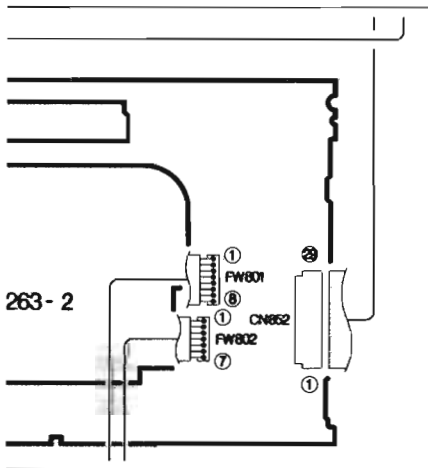
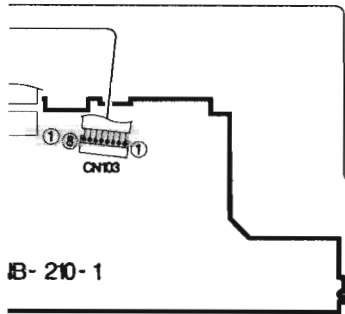
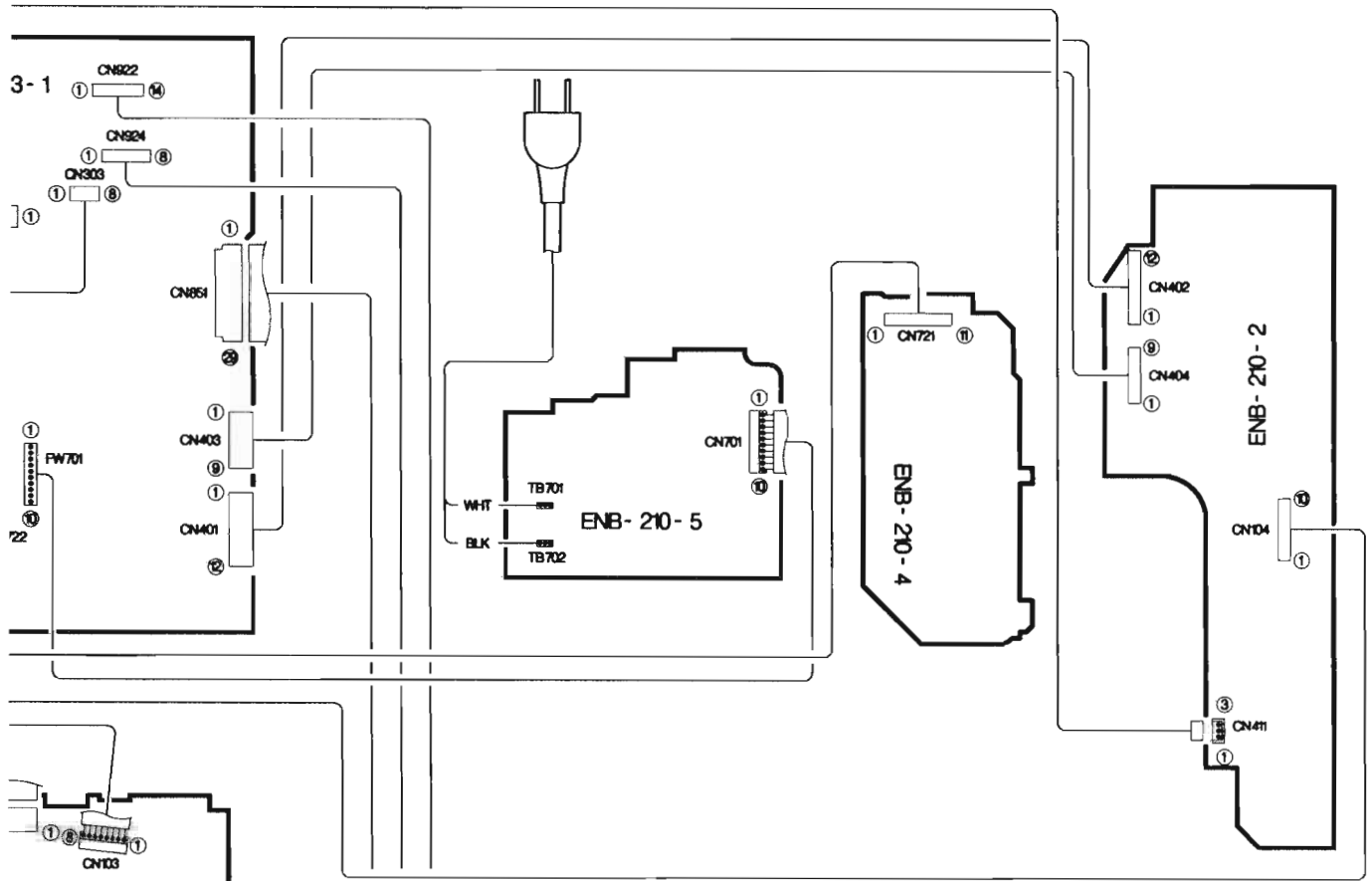

■ CD Servo & Low Pass Filter P.C.Board (ENN-443)

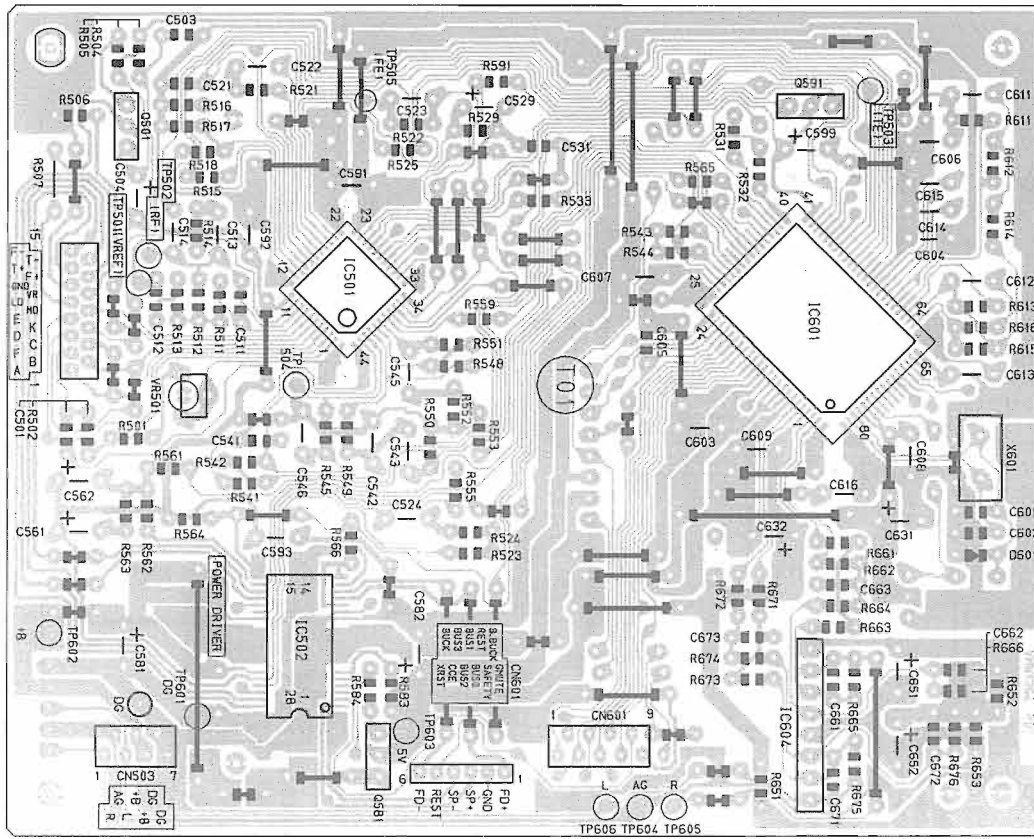

■ Tuner P.C.Board (ENA-159)

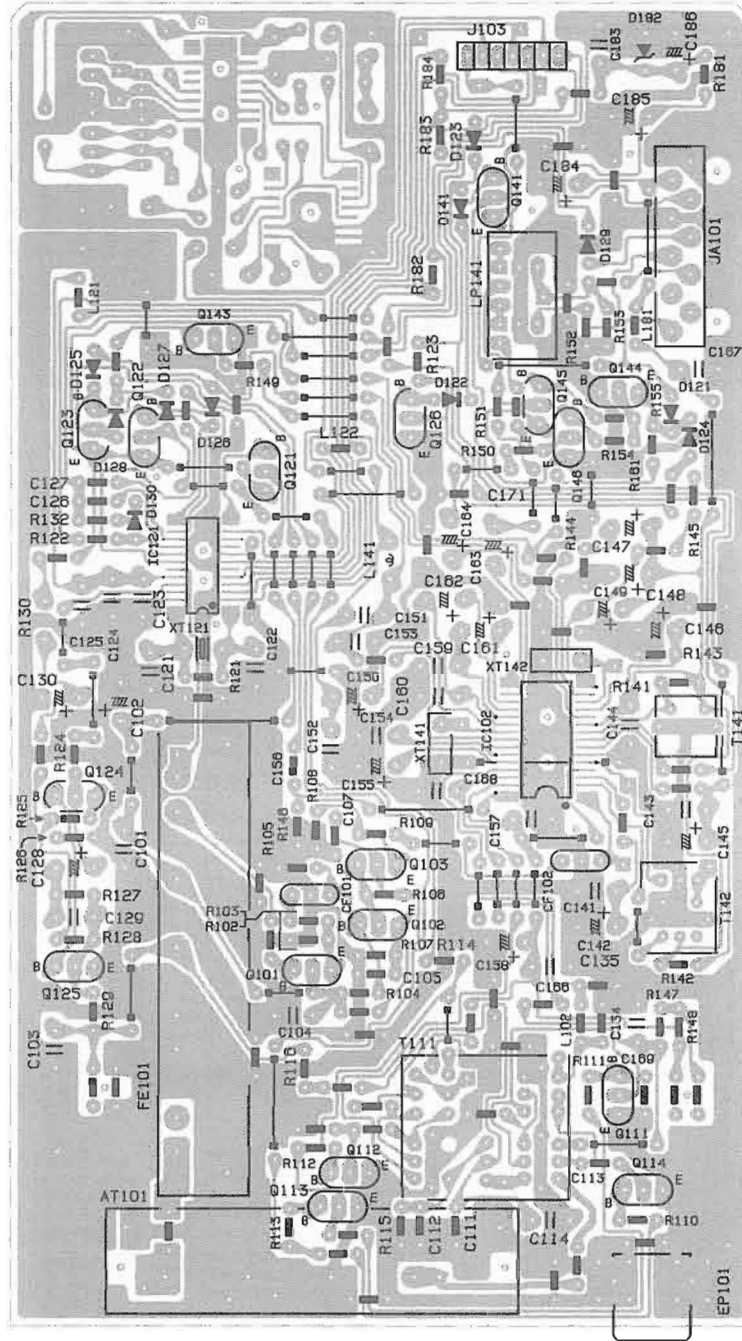

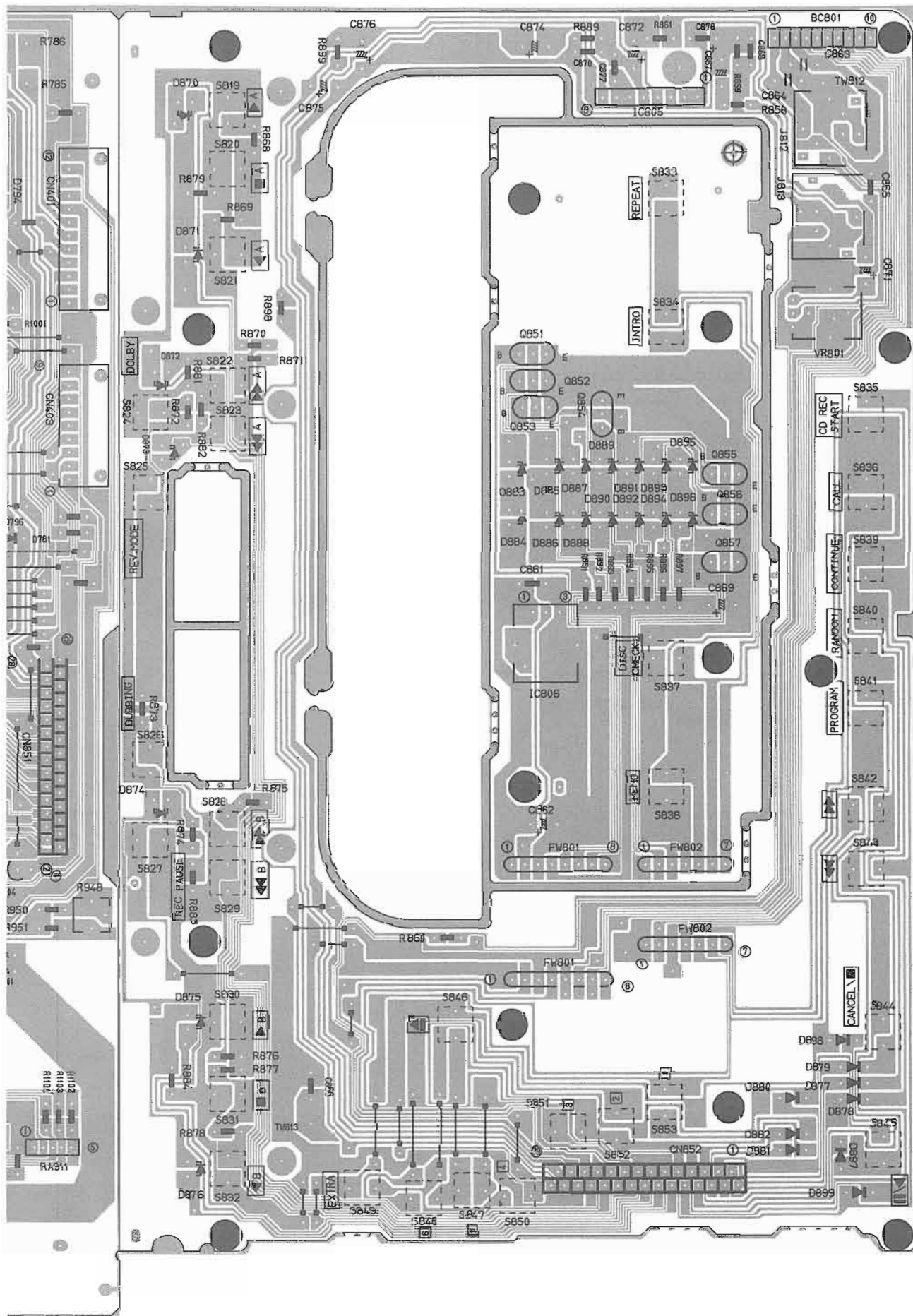

■ Tuner / CD Control, FL Display & Power Supply P.C.Board (ENB-210)

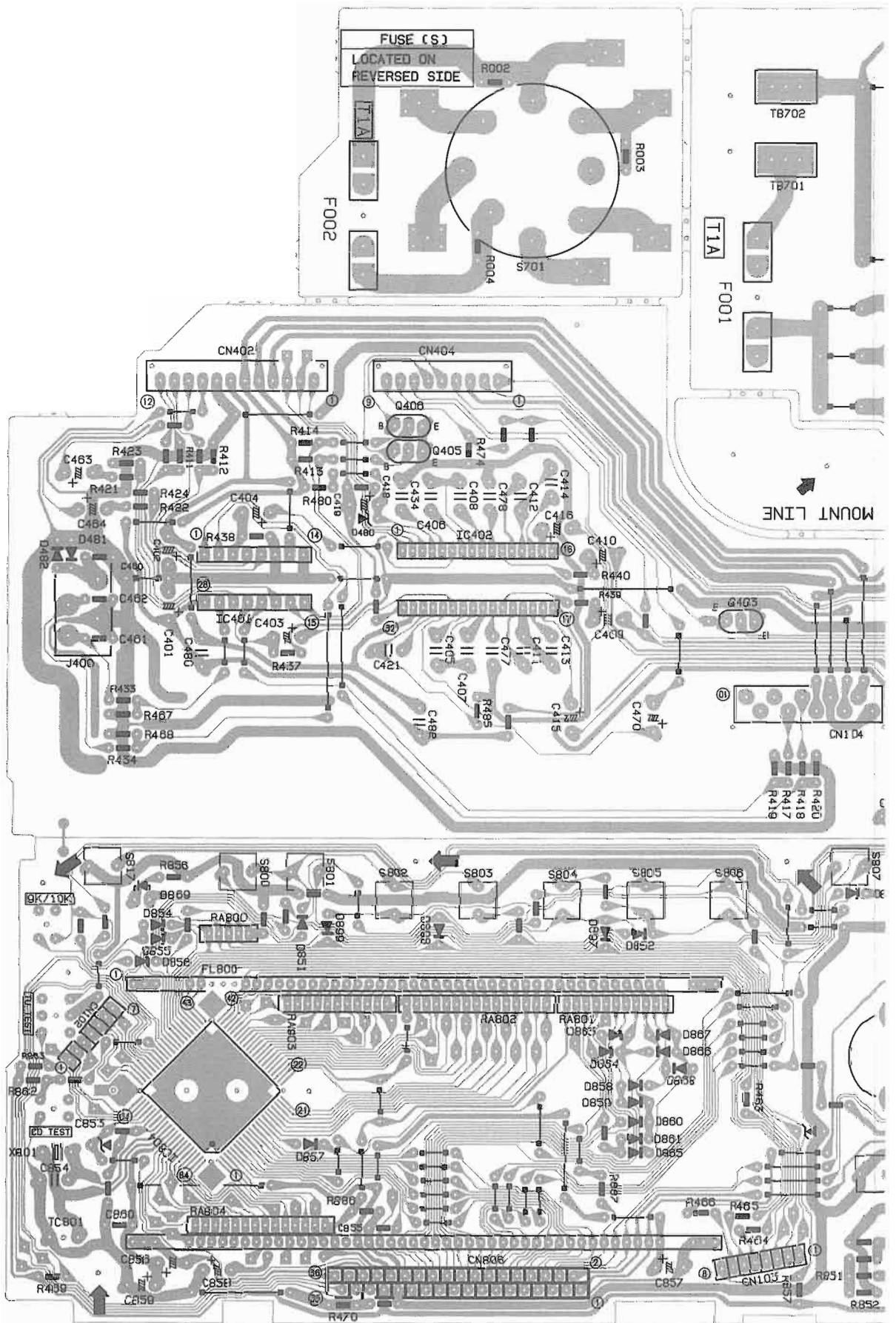

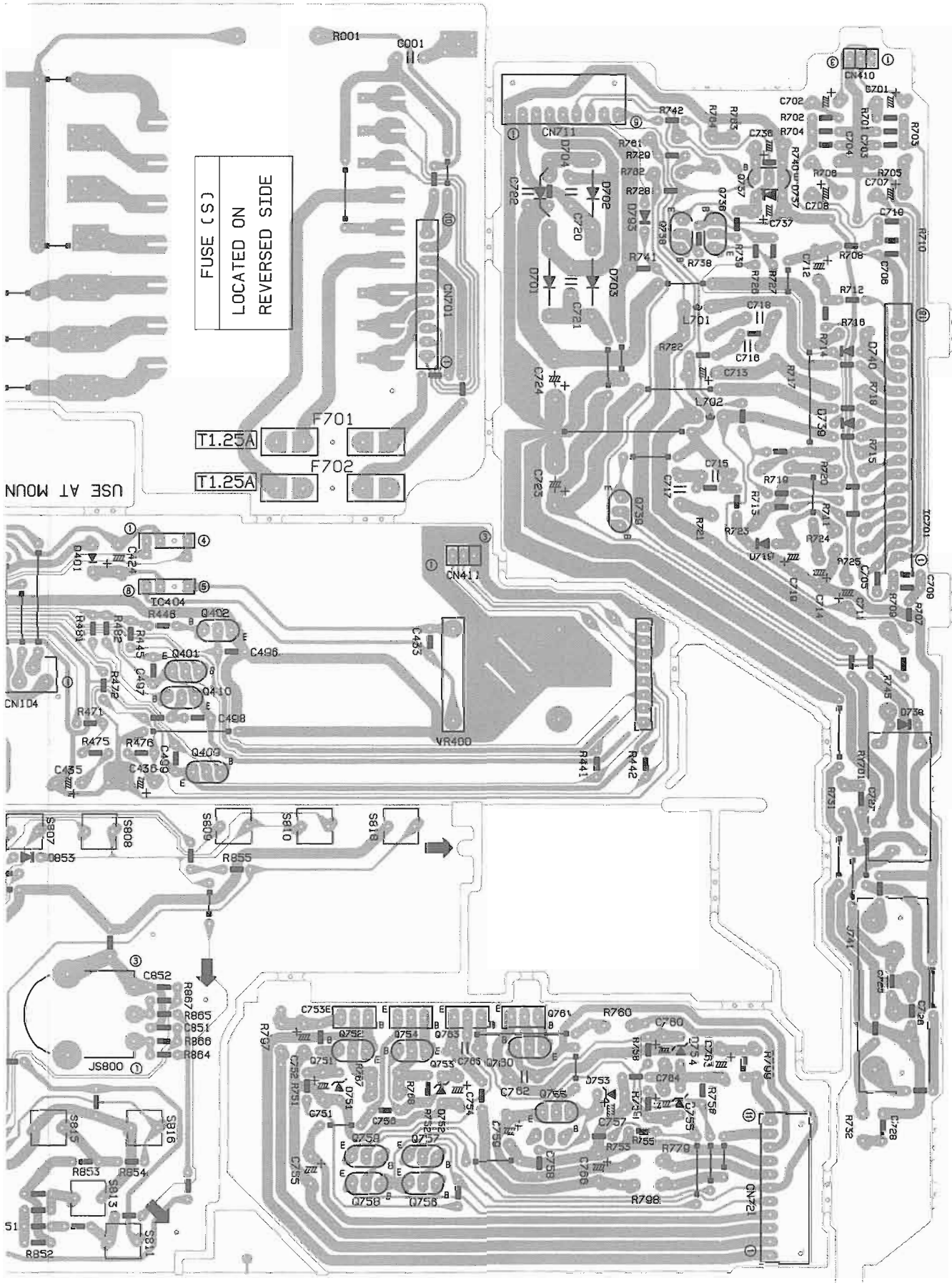

FUSE (S)
LOCATED ON
REVERSED SIDE

T1.25A
T1.25A

USE AT MOUN

51

Schematic Diagrams

Tuner Section

FOR J. C. U, UT, US, UP, A

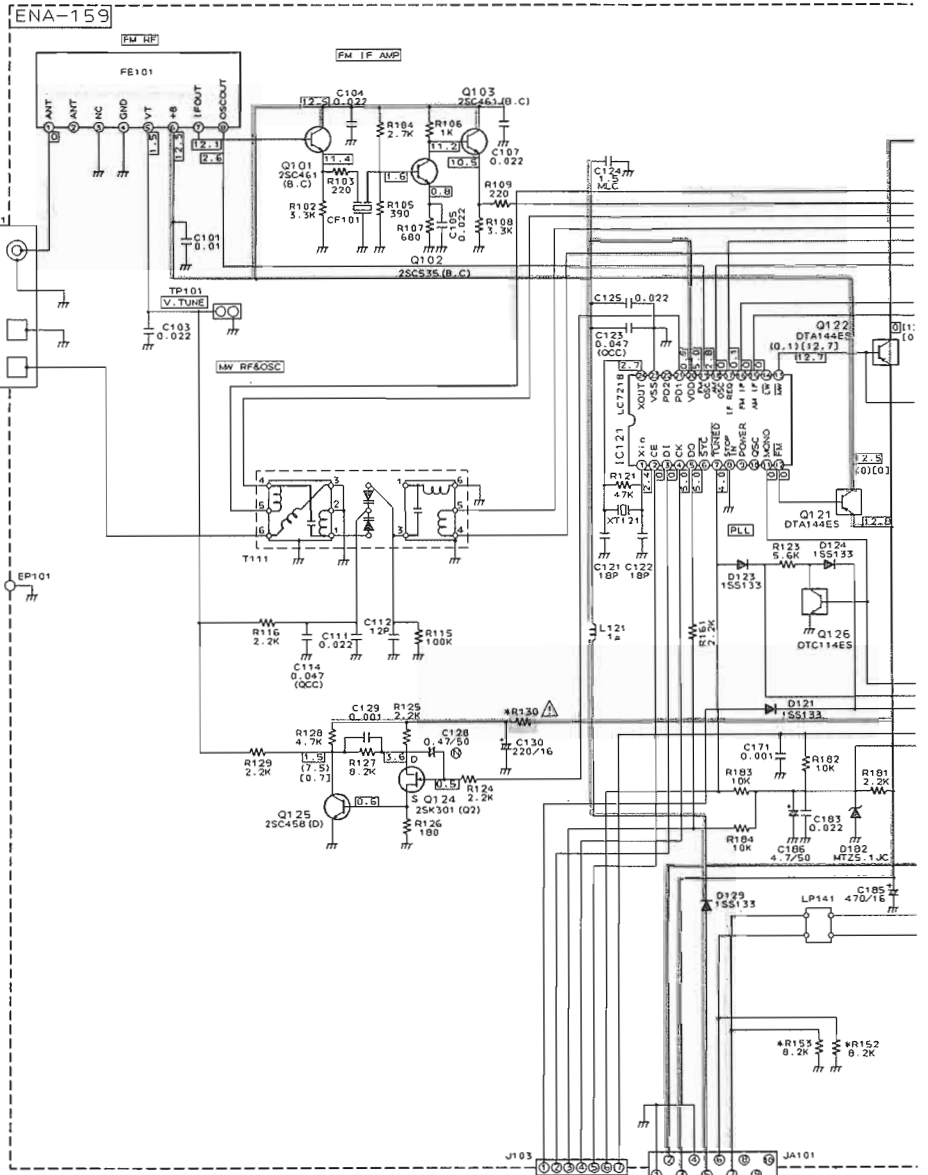

FE101
EAF2203-004

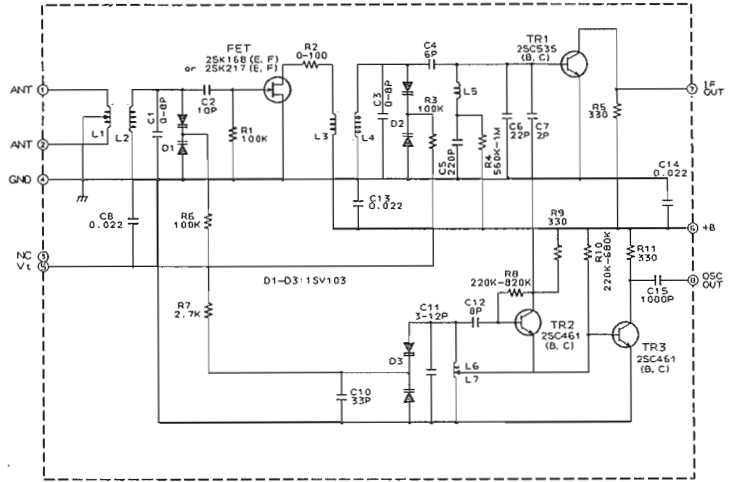

FROM CH102 OF ENA-210-1 (SHEET 3/8)

FROM CH104 OF ENA-210-2 (SHEET 3/8)

J | K | L | M | N | O | P | Q | R | S | T

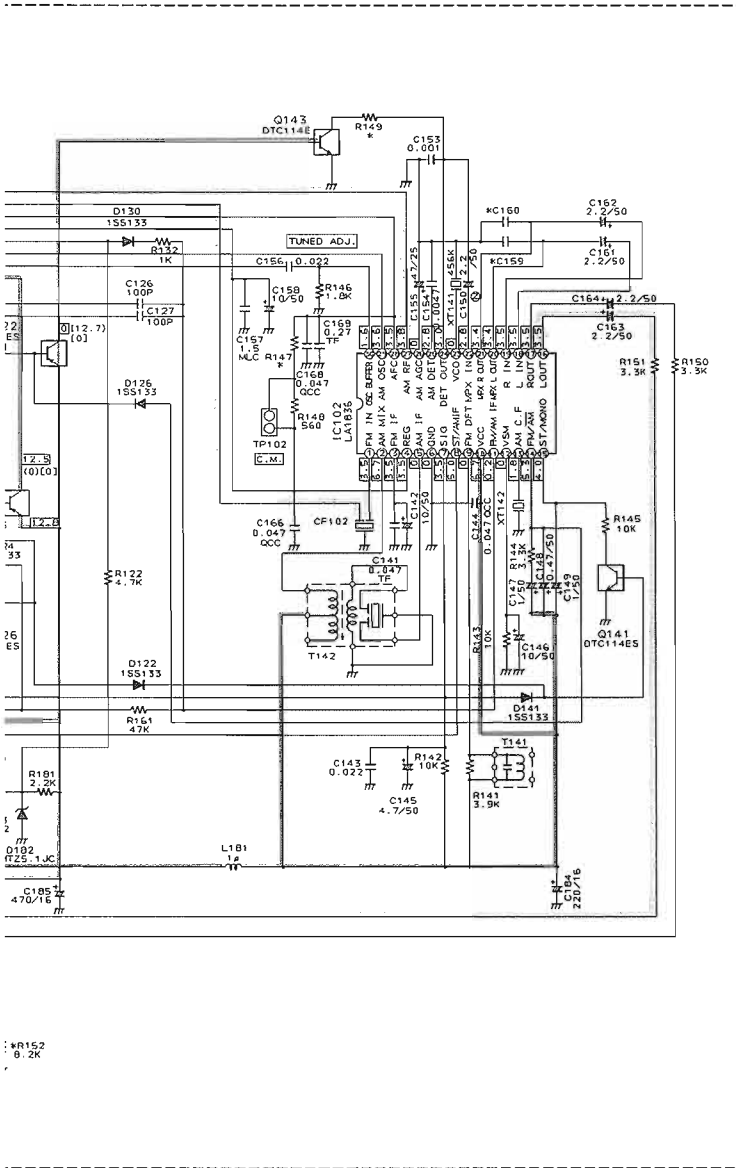

* MARK	U. U.T. US. UP	A	J. C
C159, 160	0.033	0.022	0.033
R130	68 UNF. F. (1/4W)	68 UNF. F. (1/4W)	68 UNF. C. (1/4W)
R147	47K	47K	22K
R149	22K	10K	22K
R152, 153	3.3K	8.2K	3.3K

□ FM AUTO NO SIGNAL
 () LMW NO SIGNAL
 [] LW NO SIGNAL

- Notes:
1. — indicates +B power supply.
 2. — indicates -B power supply.
 3. ■ indicates Main signal path.
 4. ■ indicates Recording signal path.
 5. ■ indicates Mic signal path.
 6. When replacing the parts in the darkened are (■) and those marked with △, be sure to use the designated parts to ensure safety.
 7. This is the standard circuit diagram. The design and contents are subject to change without notice.

CD Servo & Low Pass Filter Section

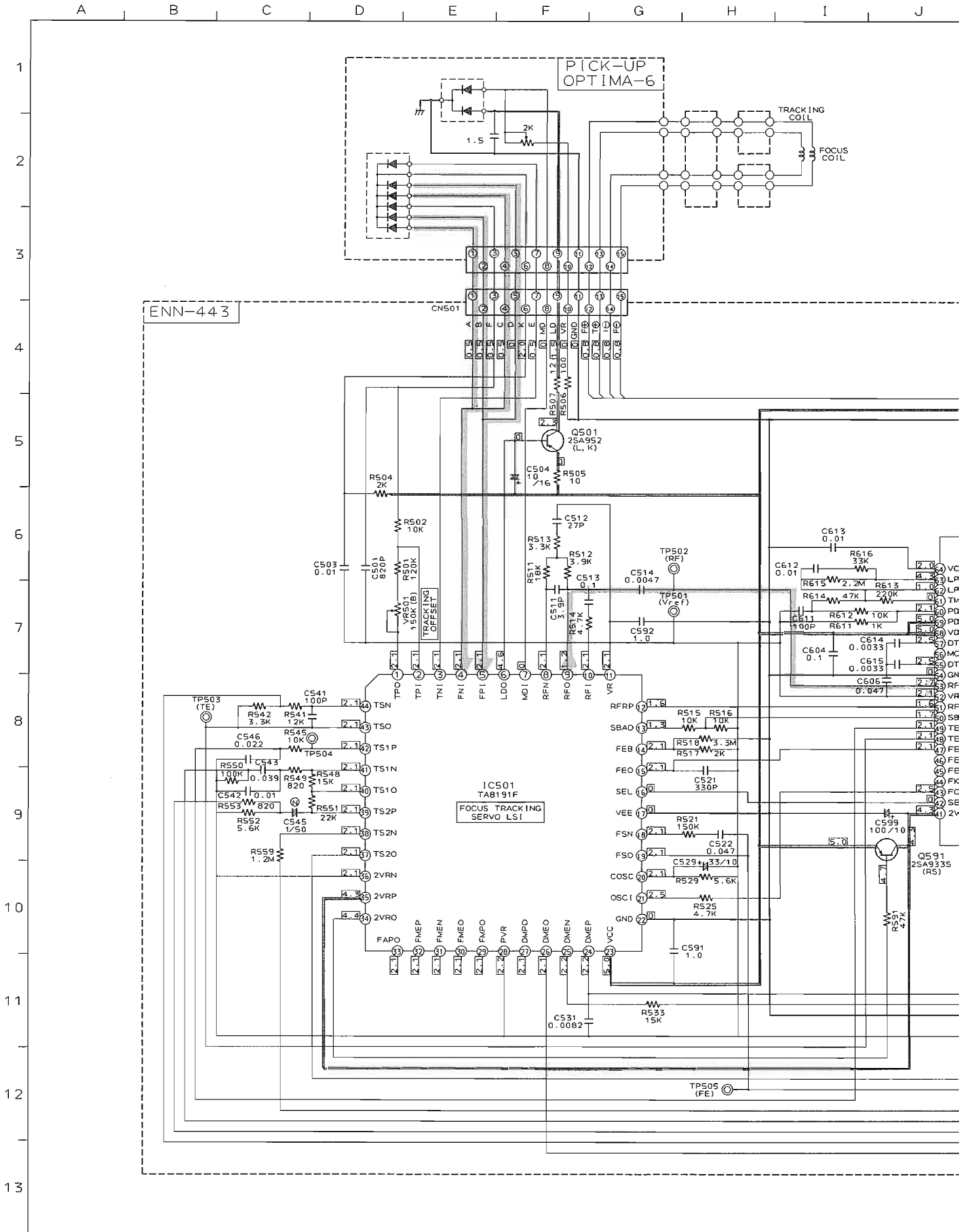

J K L M N O P Q R S T

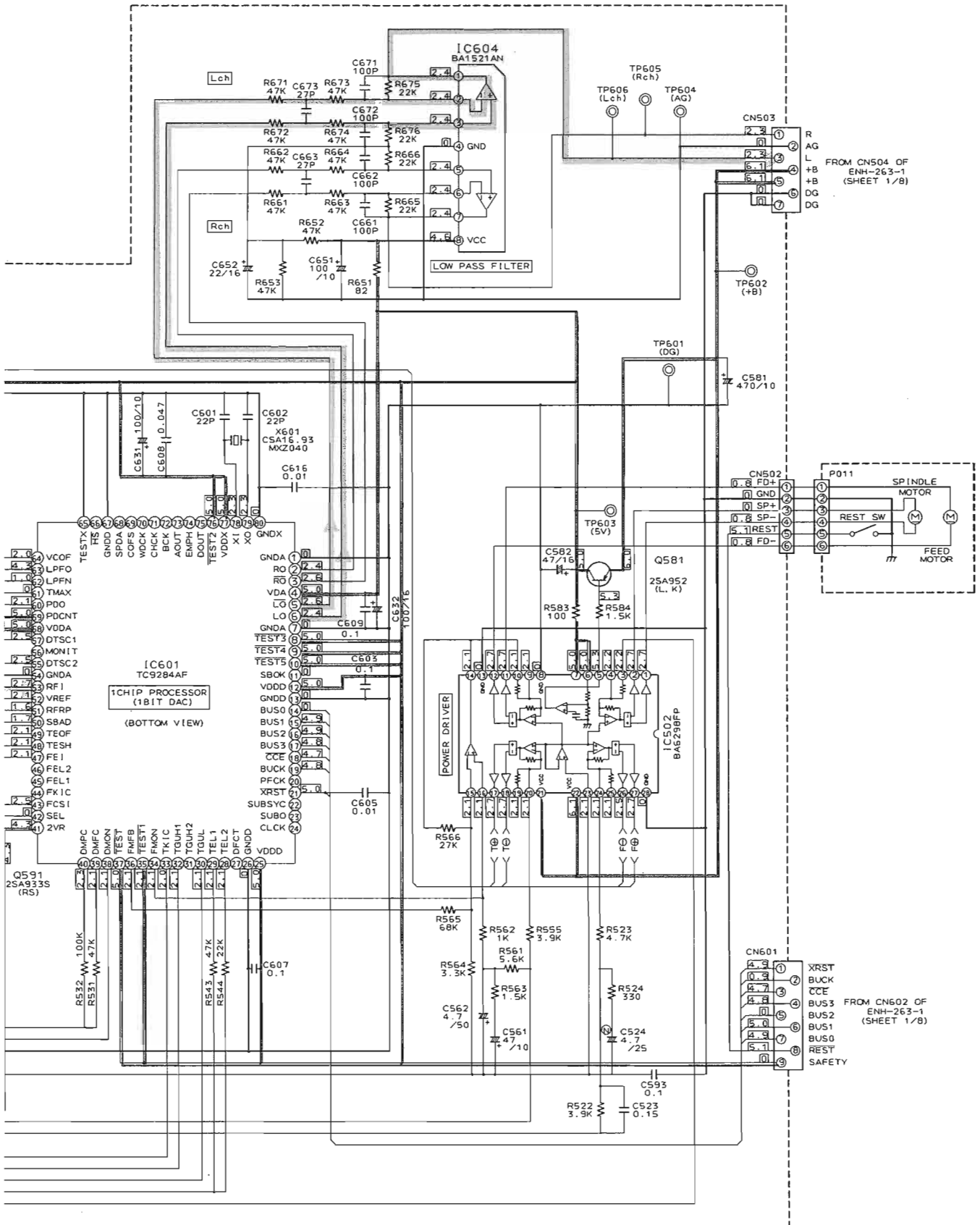

■ CD Changer Mechanizm Control Section

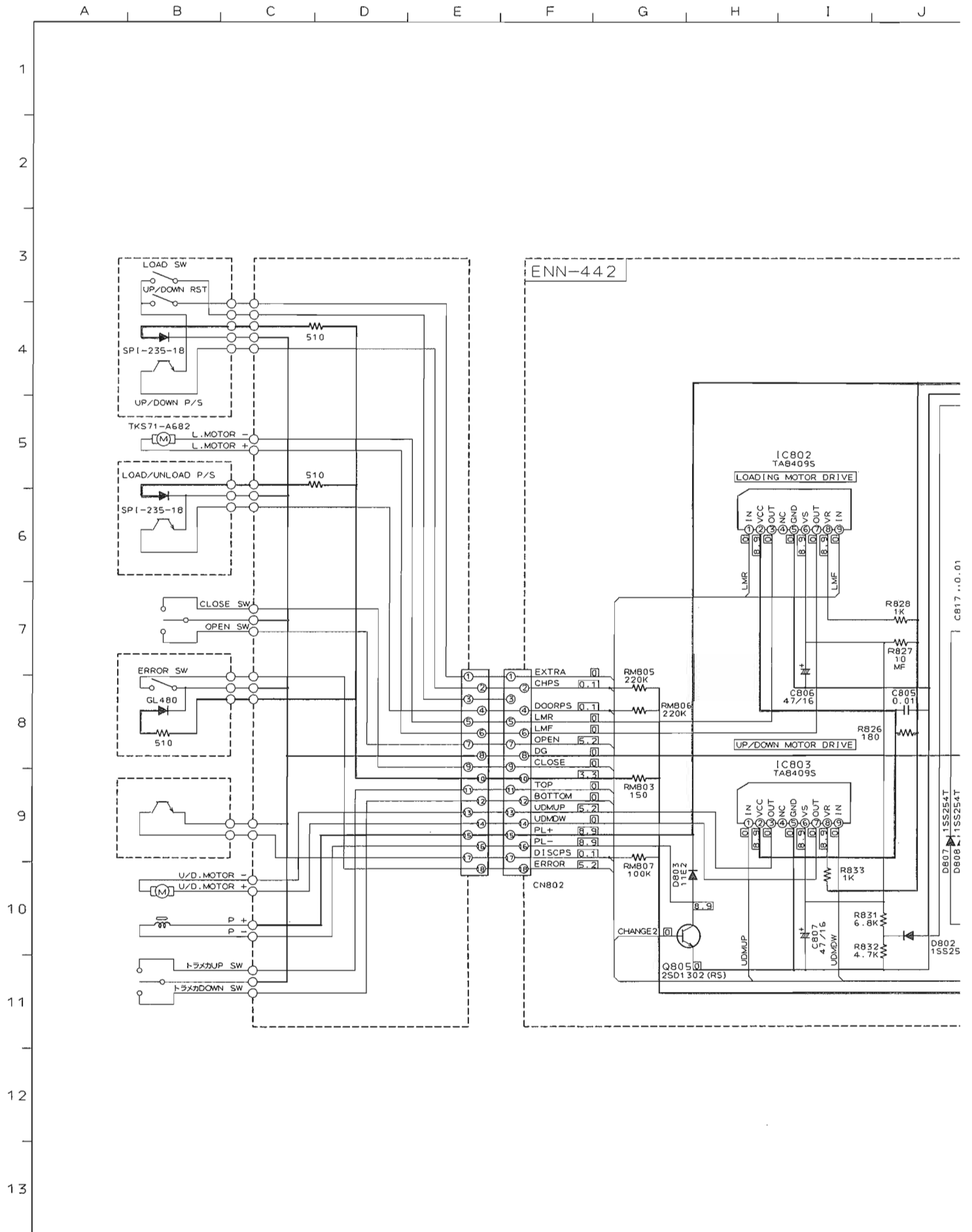

FROM CN803 OF ENN-263-1
(SHEET 1/8)

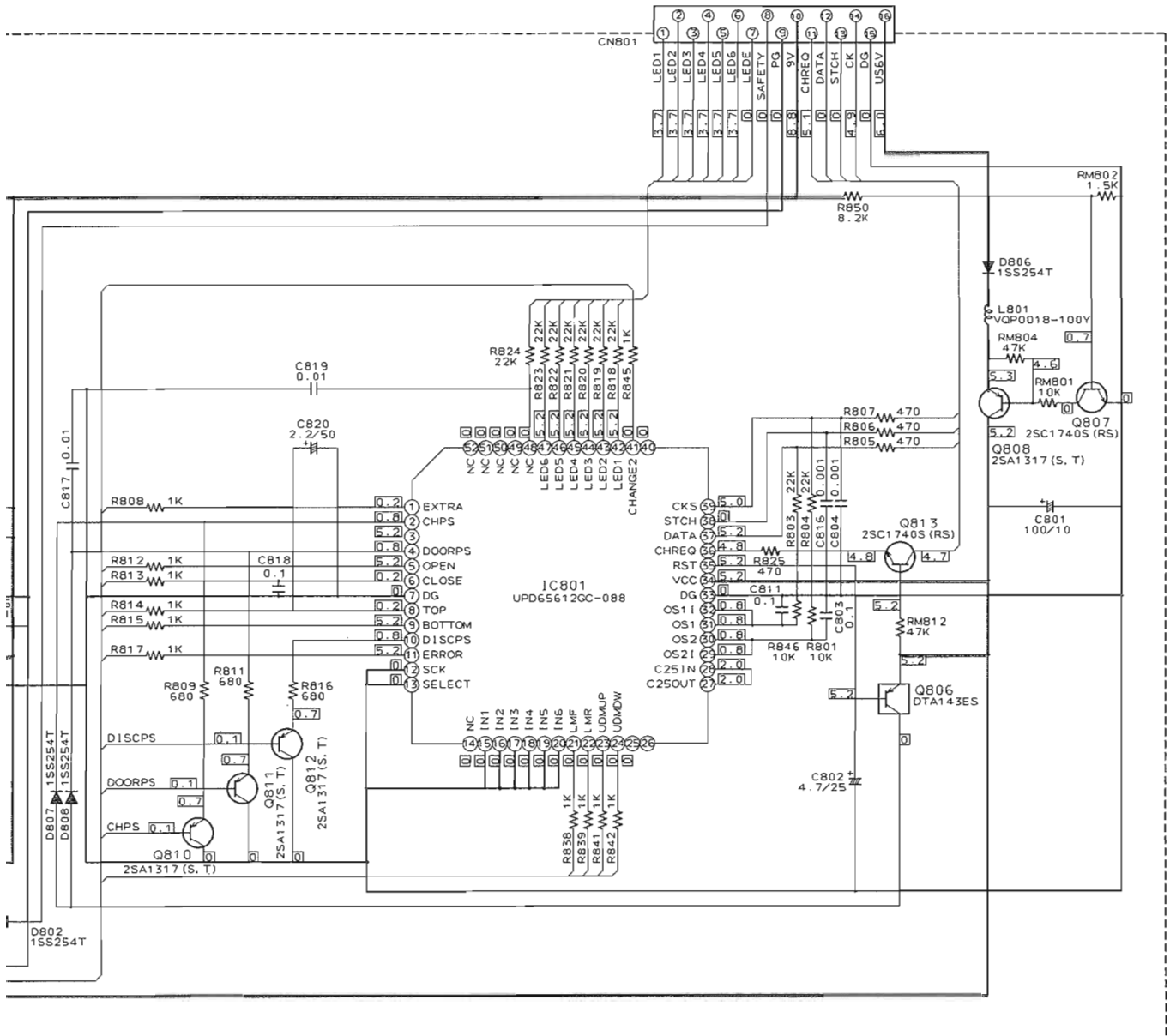

Cassette Amplifier, Dolby NR & Bias Qscillator Section

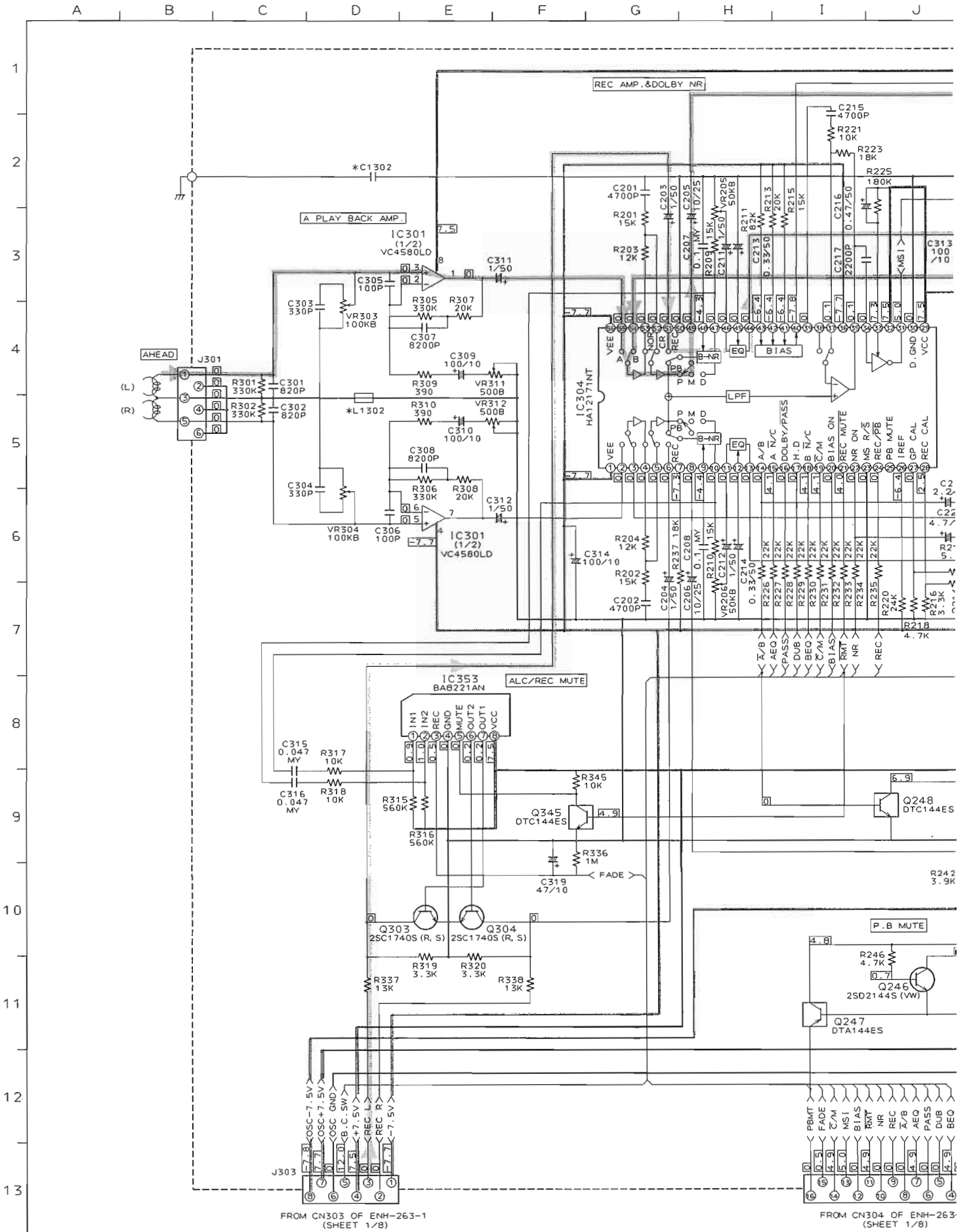

FROM CN303 OF ENH-263-1 (SHEET 1/8)

FROM CN304 OF ENH-263-1 (SHEET 1/8)

J K L M N O P Q R S T

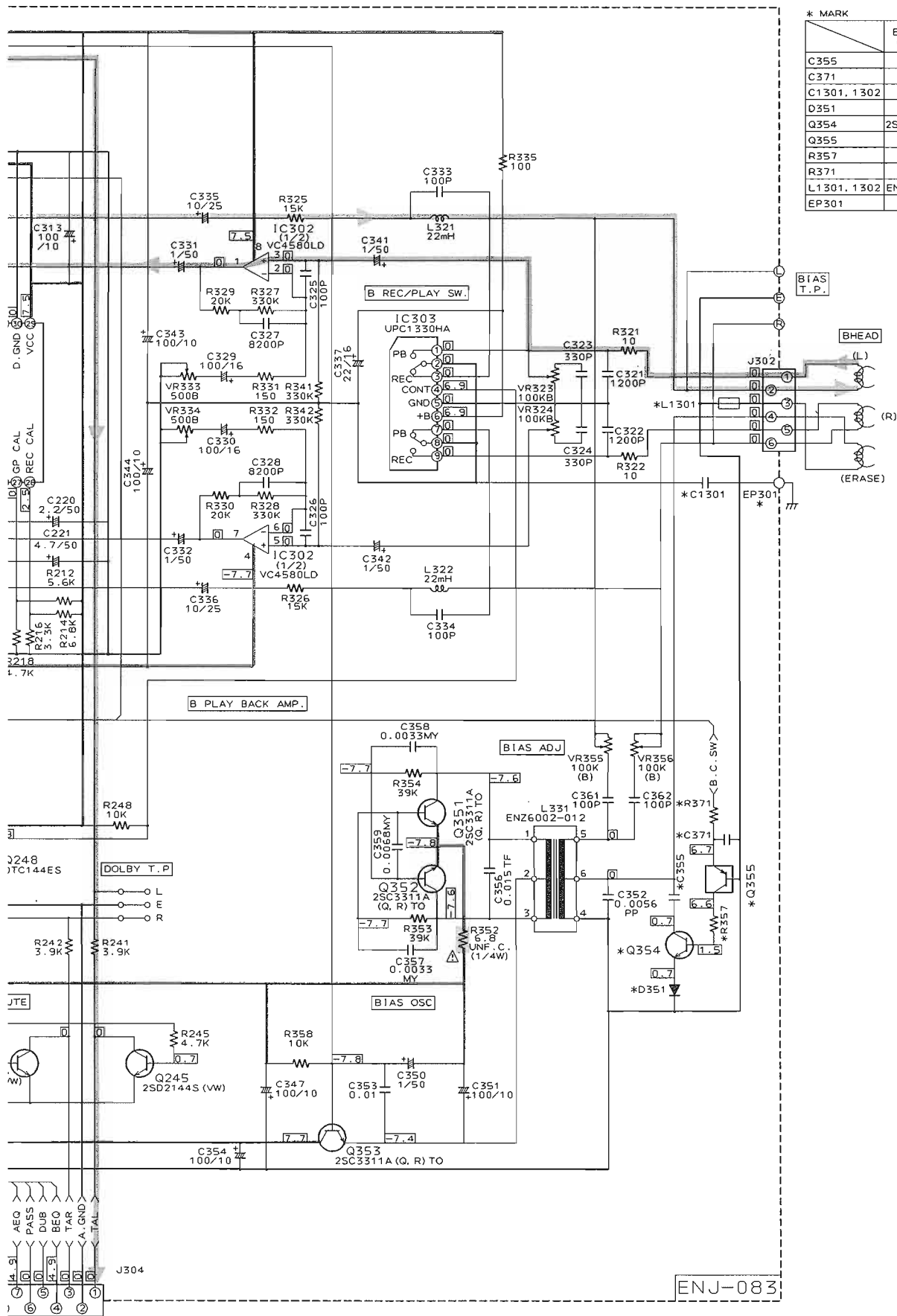

* MARK

	BS, EF, EN, G, GI, VX	OTHER
C355	470P	NONE
C371	0.022	NONE
C1301, 1302	0.001	NONE
Q351	1SS119	NONE
Q354	2SC945A (P, Q)	NONE
Q355	DTA144E	NONE
R357	1K	NONE
R371	1K	NONE
L1301, 1302	ENZ8001-007	NONE
EP301	USED	NONE

■ Power Supply Section

A | B | C | D | E | F | G | H | I | J

1

2

3

4

5

6

7

8

9

10

11

12

13

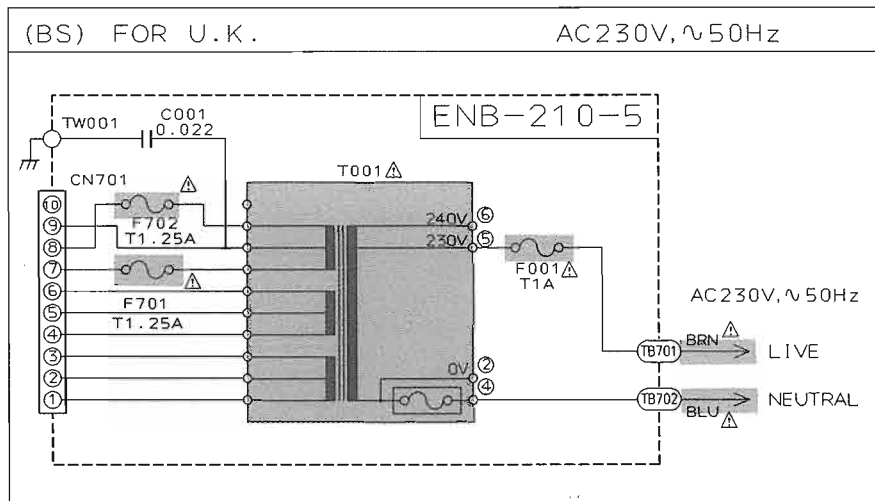
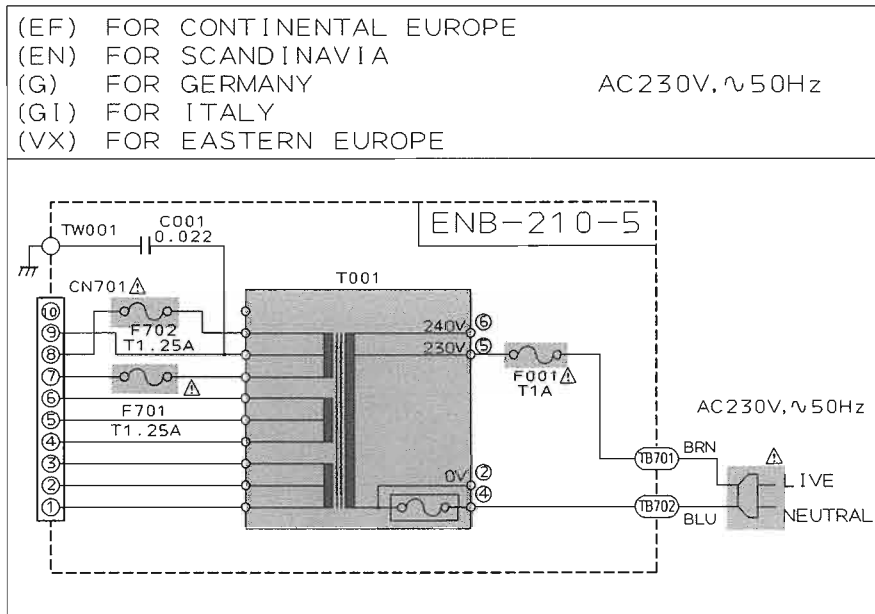
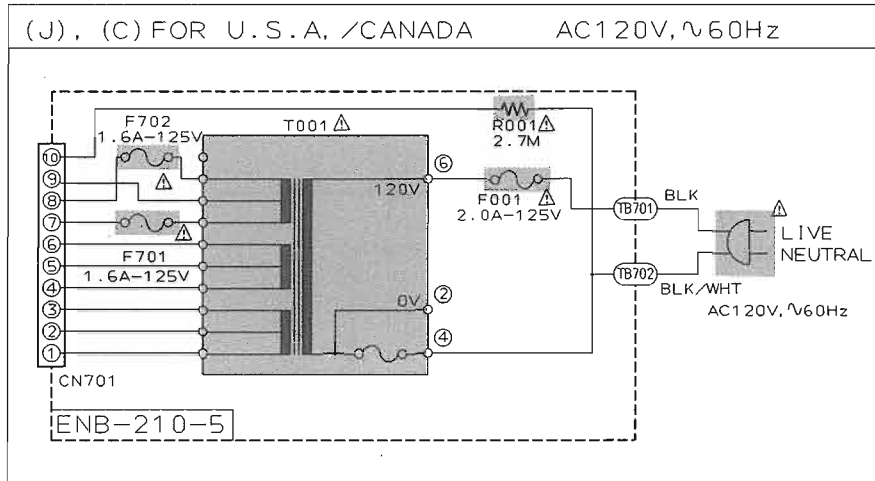

(U) FOR OTHER COUNTRIES AC110V/127V/220V/230V-240V
 (UT) FOR TAIWAN ~50Hz/60Hz
 (US) FOR SINGAPORE

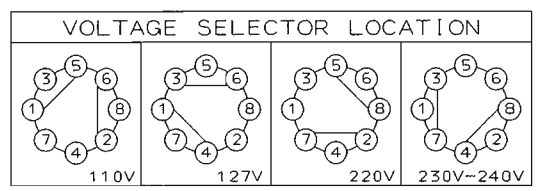
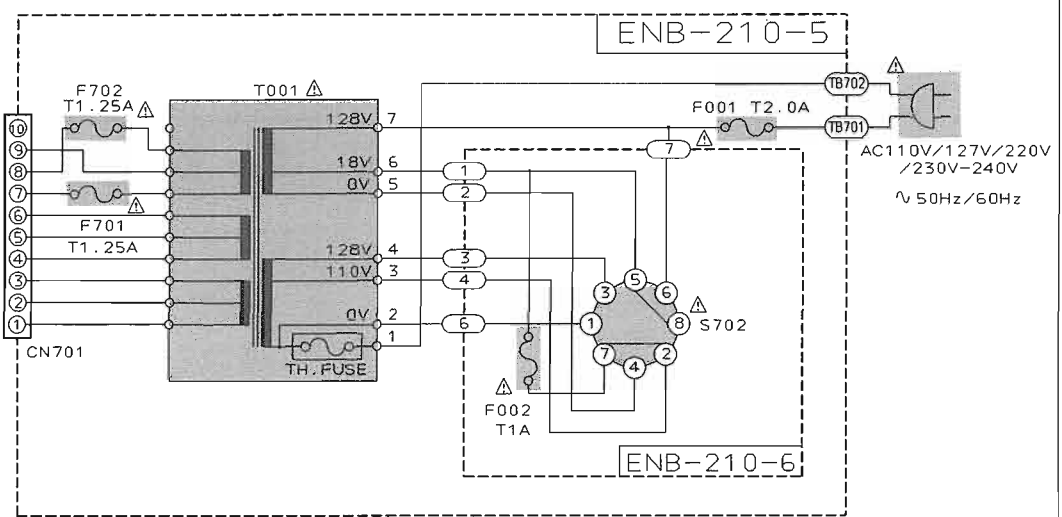

(A) FOR AUSTRARIA AC 240V, ~50Hz

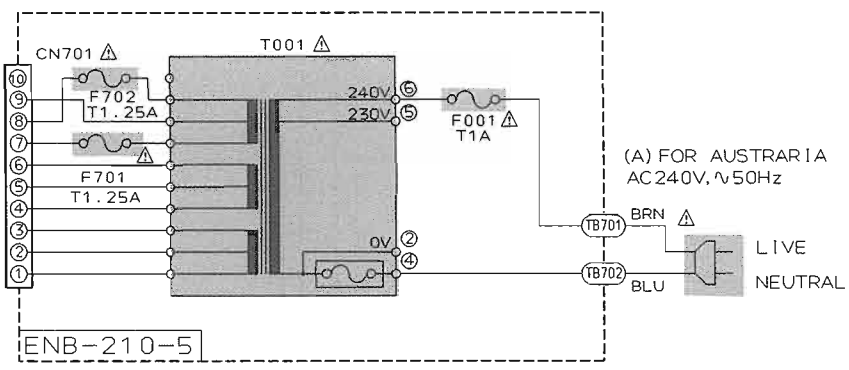

P1-57-a

P1-57-b

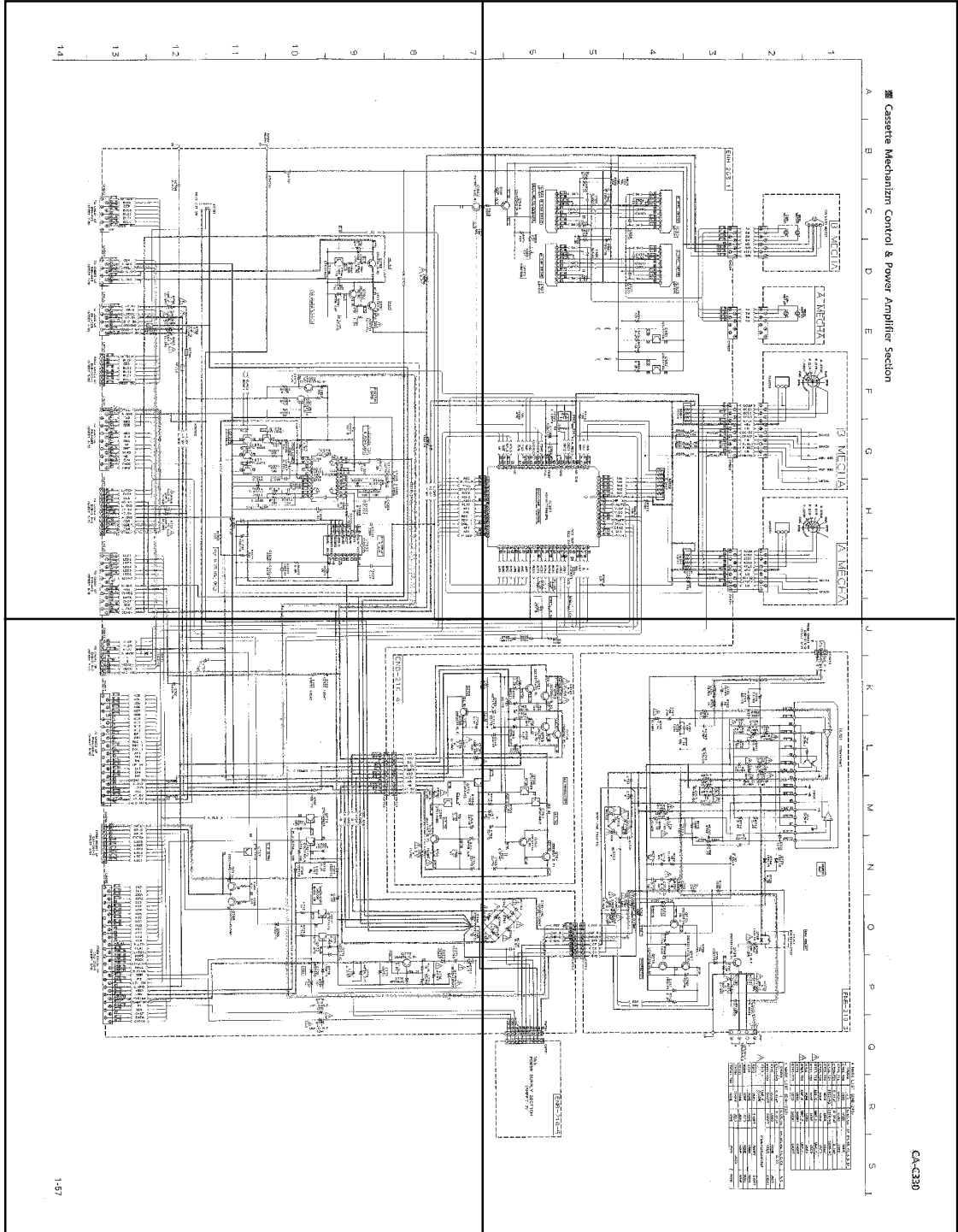

P1-57-c

P1-57-d

7
8
9
10
11
12
13
14

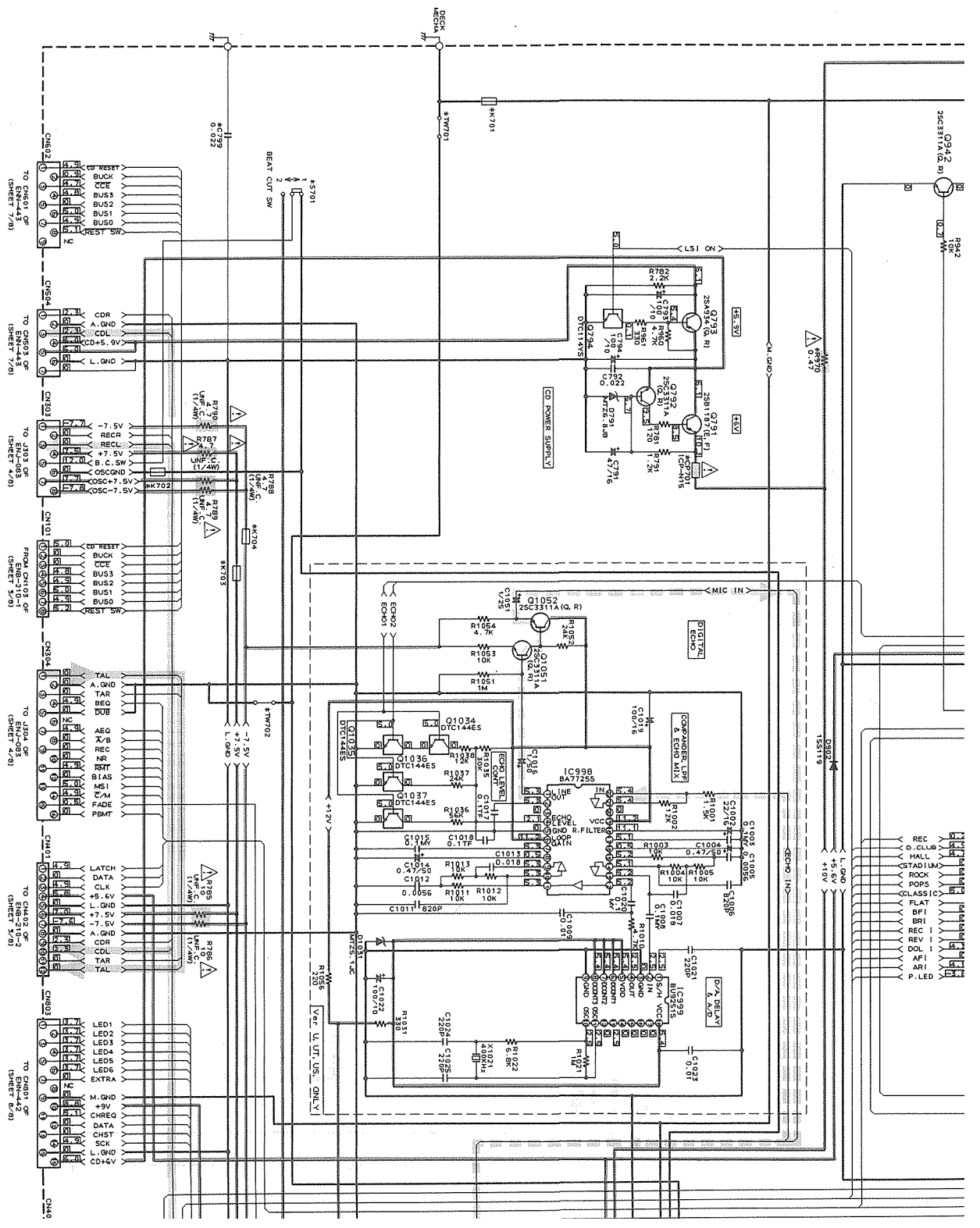

Cassette Mechanism Control & Power Amplifier Section

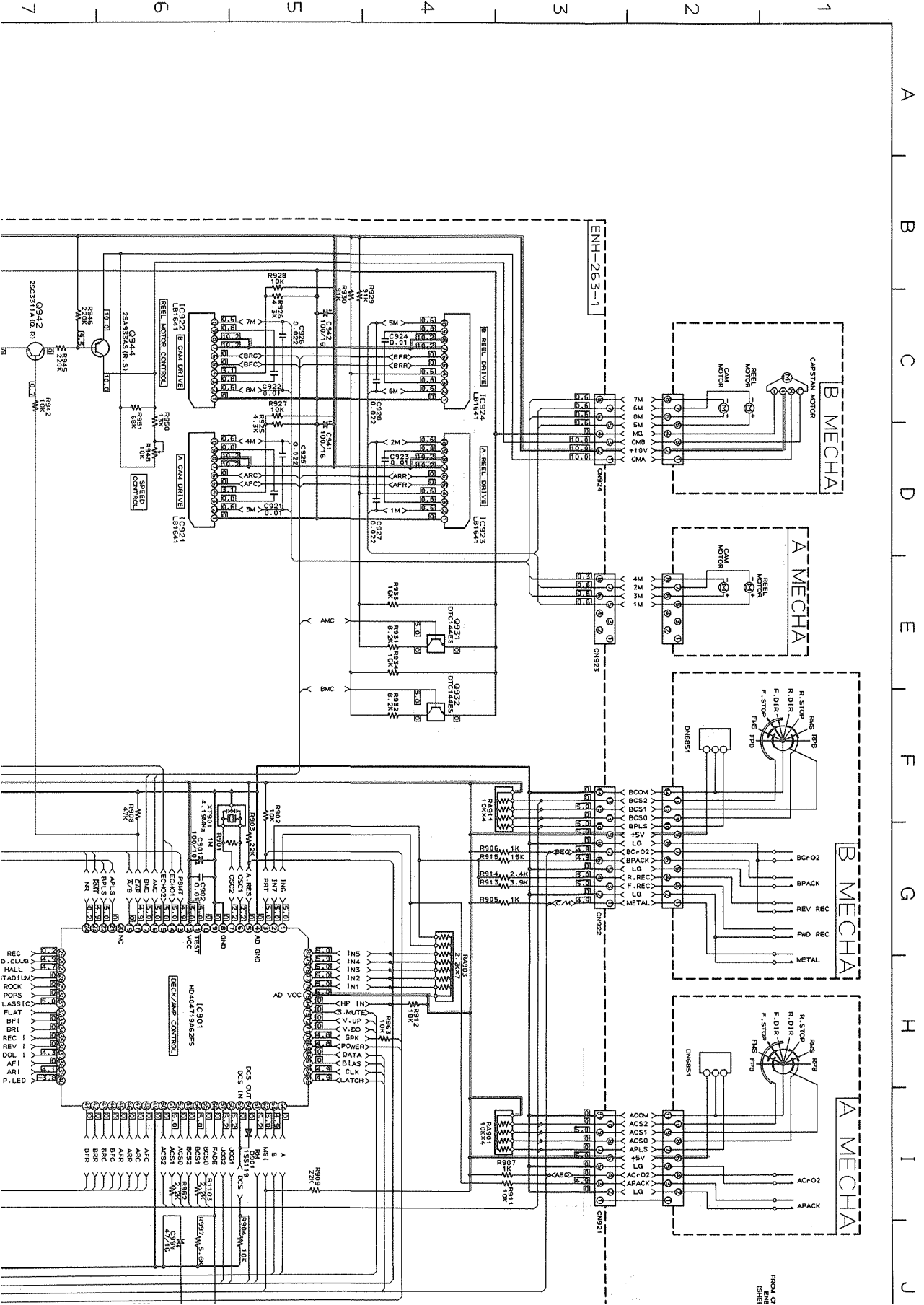

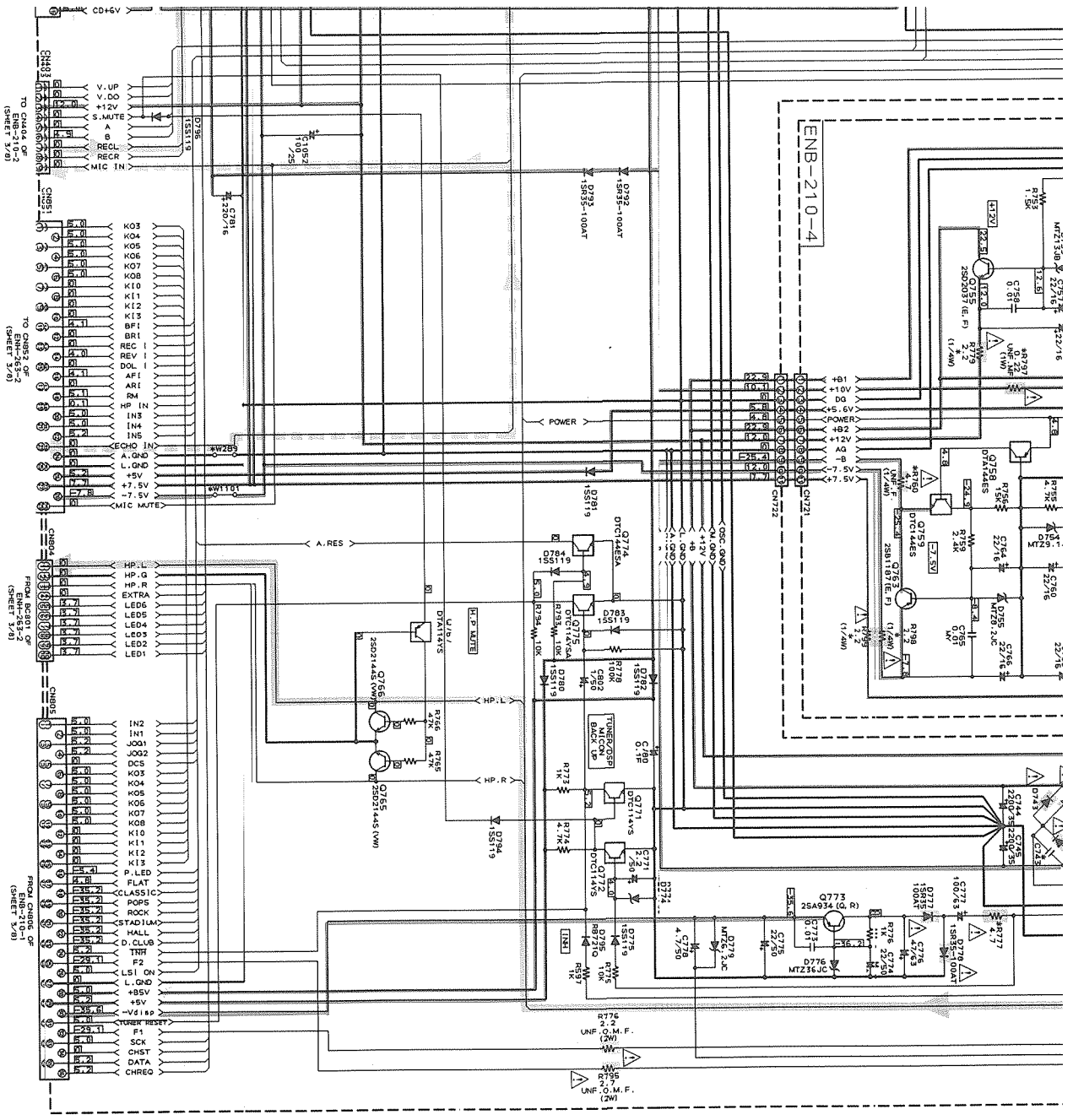

P1-58-a

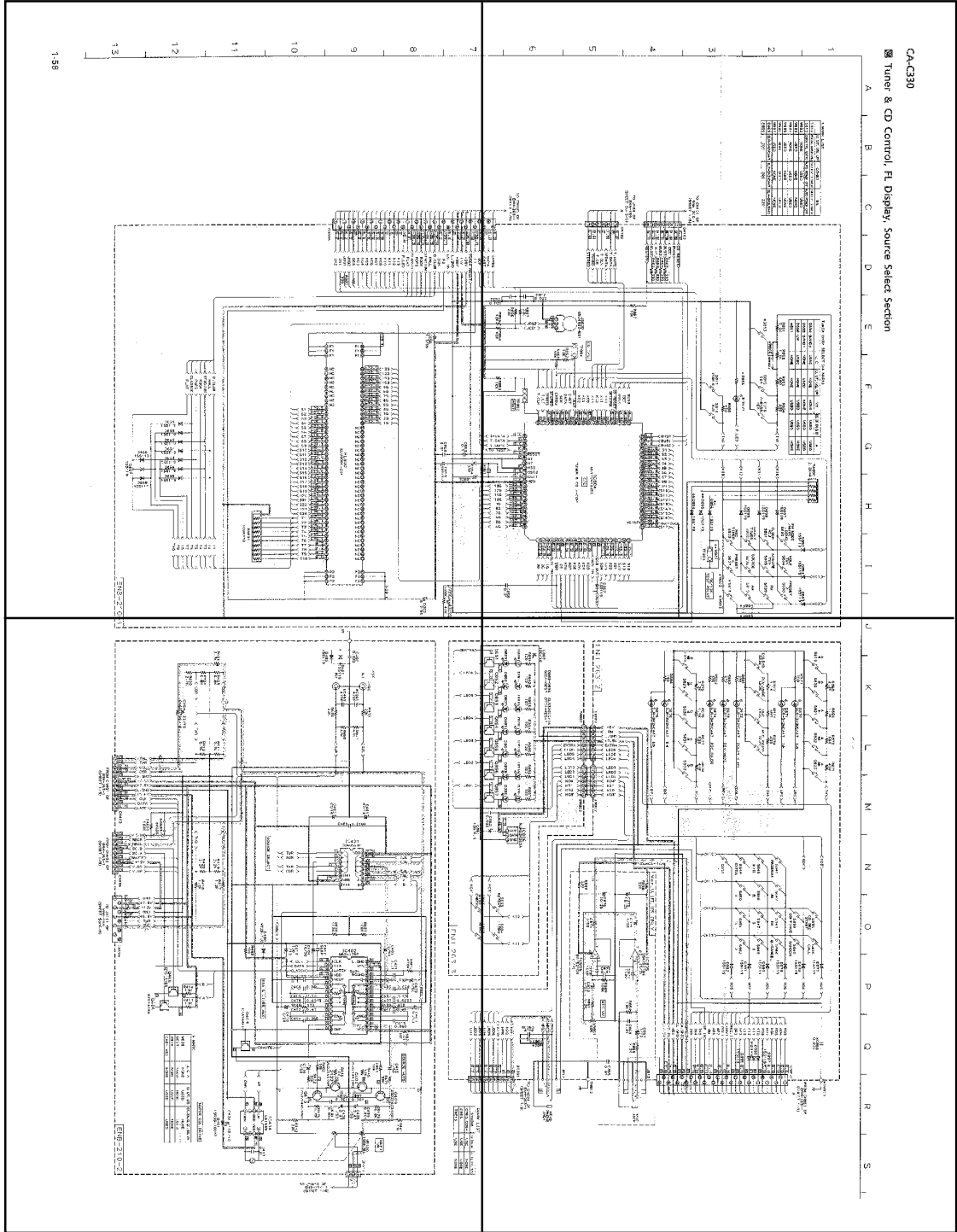

P1-58-b

P1-58-c

P1-58-d

7
8
9
10
11
12
13

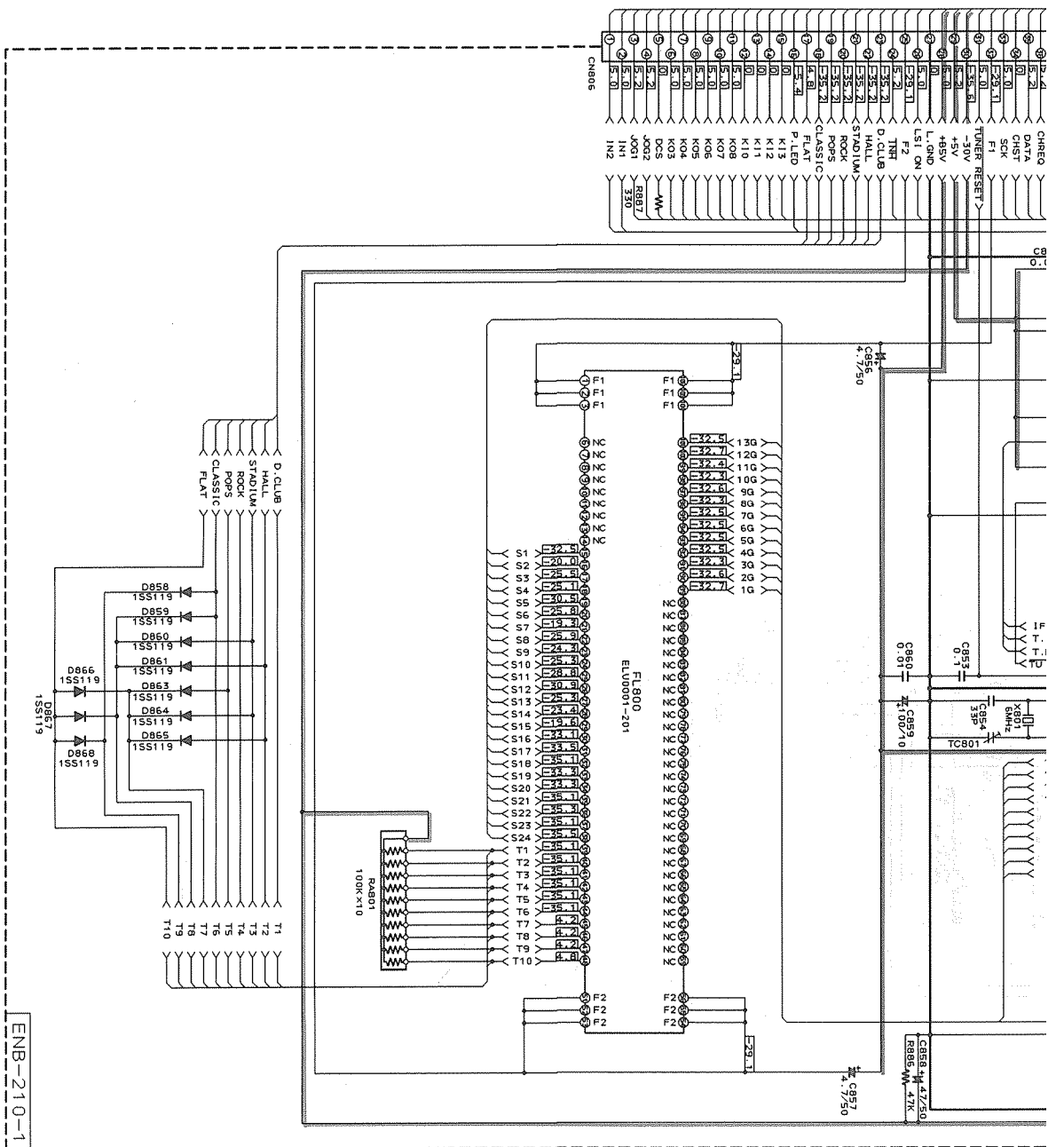

ENB-210-1

Tuner & CD Control, FL Display, Source Select Section

* MARK LIST

U/UT	US	UP	OTHER	BS				
S811	KCAL	WASHING	SLEEP	TIMER	SLEEP	TIMER		
S813	DIGITAL	EQD	AUTO	POWER	OFF	AUTO	POWER	OFF
W802	NONE	USED	USED	NONE	NONE	NONE		
W803	NONE	USED	USED	NONE	NONE	NONE		
W804	NONE	USED	USED	NONE	NONE	NONE		
W805	USED	USED	USED	NONE	NONE	NONE		
W806	NONE	USED	USED	NONE	NONE	NONE		
W807	USED	USED	USED	NONE	NONE	NONE		
D869	S.L.R-342CM17	S.L.R-342CM17	S.L.A-390LTM17	NONE	NONE	NONE		
R856	200	200	220					

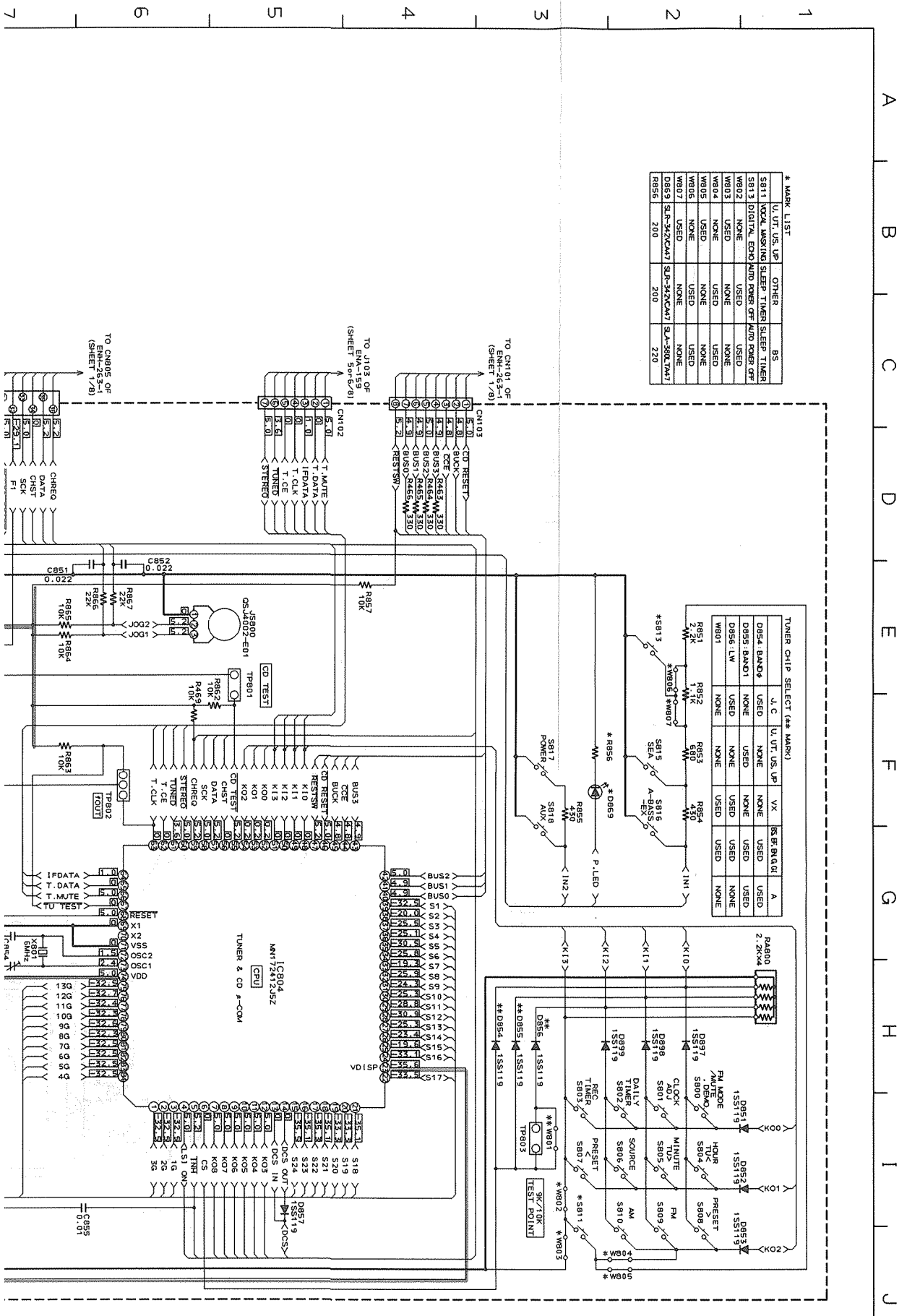

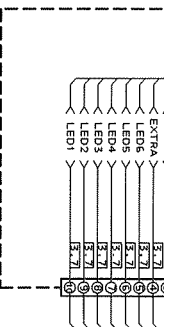
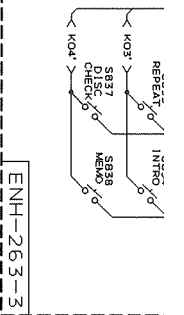
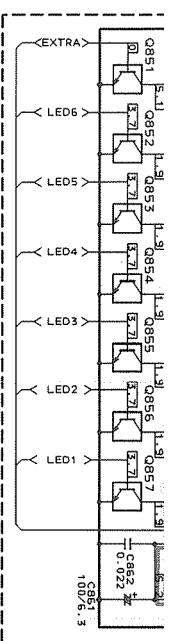

MARK LIST

SYMBOL	OTHER	U. U. UT. US
CB63, CB64	USE	NONE
CB66	USE	NONE
TW61, 3	USE	NONE

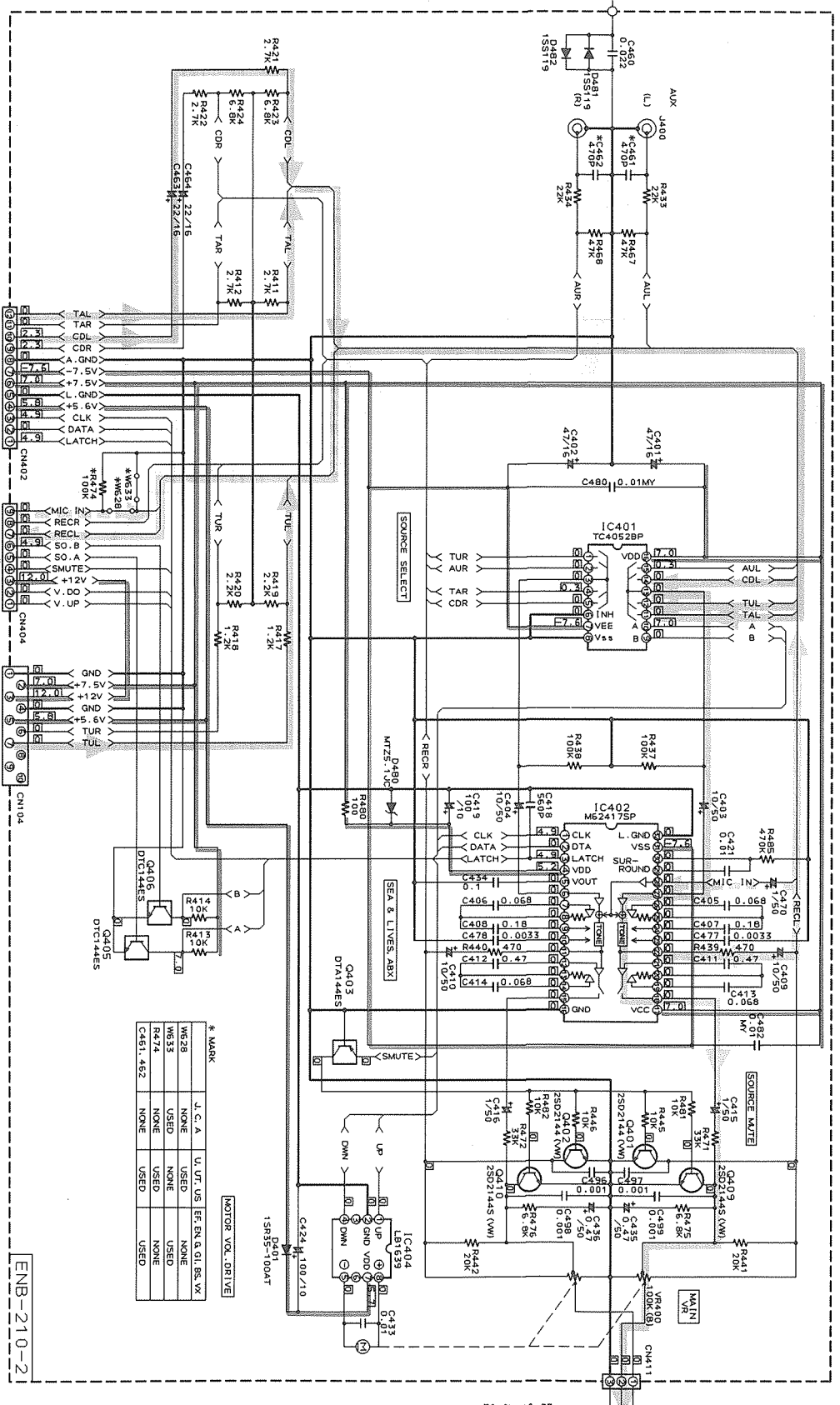

* MARK

J.C. A	U. UT. US	EF. EN. G. I. BS. VV
W628	NONE	NONE
W633	USED	NONE
R474	USED	NONE
C461, 462	NONE	USED

FROM CH401 OF (SHEET 1/8)

FROM CH403 OF (SHEET 1/8)

TO J4101 OF (SHEET 506/6)

ENB-210-2

PARTS LIST

Note : All printed circuit boards and its assemblies are not available as service parts.

Contents

General Exploded view and Parts List	2-2
CD Changer Mechanizm Ass'y and Parts List	2-5
CD Mechanizm Ass'y and Parts List	2-7
Cassette Mechanizm Ass'y and Parts List	2-8
Printed Circuit Board Ass'y and Parts List	2-9
■ ENN-442 □ CD Changer Mechanizm Control PC Board Ass'y	2-9
■ ENN-443 □ CD Servo & Low Pass Filter PC Board Ass'y	2-10
■ ENA-159 □ Tuner PC Board Ass'y	2-12
■ ENJ-083 □ Deck Amp., EQ & NR PC Board Ass'y	2-15
■ ENH-263 □ Indicator, Key & Deck / Amp. Control PC Board Ass'y	2-18
■ ENB-210 □ Tuner / CD Control, FL Display & Power Supply PC Board Ass'y ..	2-23
Accessories List	2-28
Packing Materials and Part Numbers	2-29

■ Parts List

Symbol No.

M	1	M	M
---	---	---	---

△	Item	Part Number	Part Name	Q'ty	Description	Area
	1	EFP-CAC330E(S)	FRONT PANEL	1		A,BS,C,EF,EN,G,GI,J,VX
		EFP-CAC330U(S)	FRONT PANEL	1		U,US,UT
	1-1	E103009-003SS	FRONT PANEL	1		U,US,UT
		E103009-004SS	FRONT PANEL	1		A,BS,C,EF,EN,G,GI,J,VX
	1-2	E208491-002SS	WINDOW SCREEN	1		
	1-3	E208489-001SS	WINDOW SCREEN	1		
	1-4	E69777-003	REFLECTION PLATE	2		
	1-5	E406971-221	JVC MARK	2		
	2	FSJT2003-001SA	CASSETTE LID ASSY	1		
	2-1	FSJT2003-001	CASSETTE LID	1		
	2-2	E406971-221	JVC MARK	1		
	3	FSJT2004-001	CASSETTE LID	1		
	4	E207972-004SS	CASSETTE HOLDER	1		
	5	E207973-004SS	CASSETTE HOLDER	1		
	6	E406713-001	CASSETE SPRING	4		
	7	SBST3006Z	TAPPING SCREW	24		
	8	FSXP3016-001	SELECT KNOB	1		
	9	E309084-004SS	VOLUME KNOB	1		
	10	E208487-001SS	CD FITTING	1		
	11	E304434-005	DAMPER ASSY	2		
	12	E208484-001SS	PUSH BUTTON	1		
	13	E208244-002SS	PUSH BUTTON ASSY	1		
	14	E309079-002SS	PUSH BUTTON	1		
	15	E408306-001	INDICATOR LENS	1		
	16	E408305-001	INDICATOR LENS	1		
	17	E309357-001SS	INDICATOR LENS	1		
	18	E208482-001SS	PUSH BUTTON	1		
	19	E208241-002SS	PUSH BUTTON ASSY	1		
	20	E208479-001SS	PUSH BUTTON ASSY	1		A,C,J,U,US,UT
		E208479-002SS	PUSH BUTTON ASSY	1		BS,EF,EN,G,GI,VX
	21	E208486-001SS	PUSH BUTTON	1		
	22	SDSF2608Z	SCREW	29		
	23	VWF1229-30TTB	FFC CABLE	1		
	24	VWF1236-20TTBW	CARD WIRE	1		
	25	E309081-002SS	EJECT BUTTON	1		
	26	E309082-002SS	EJECT BUTTON	1		
	27	E308681-002SS	EJECT LEVER	1		
	28	E308682-002SS	EJECT LEVER	1		
	29	E308683-002	EJECT GUIDE	1		
	30	E407798-002	SPRING	1		
	31	E407799-001	EJECT BRACKET	1		
	32	E407800-001	EJECT BRACKET	1		
	33	E407801-002	SPRING	1		
	34	E407802-002	SPRING	1		
	35	SBSF3006Z	TAPPING SCREW	2		
	36	---	CASS MECHA ASSY	1	SEE PAGE 2-8	
	37	SBSF3008Z	TAPPING SCREW	4		
	38	E208256-001	HOLDER BKT	1		
	39	FSKW4002-001	HOLDER SPRING	1		
	40	FSKW4003-001	HOLDER SPRING	1		

The Marks for Designated Areas

J	the U.S.A.	A	Australia	C	Canada	VX	East Europe
G	Germany	U	Universal	US	Singapore	UT	Taiwan
EF	Continental Europe	EN	Scandinavia	GI	Italy	BS	the U.K.

No mark indicates all area.

△	Item	Part Number	Part Name	Q'ty	Description	Area
	41	VYH2285-003	P.W.BOARD BRACKET	1		
	42	VWF1218-14TTB	CARD WIRE	1		
	43	VWF1015-07TTA	FLAT WIRE	1		
	44	E103011-001SS	CHASSIS BASE	1		
	45	E309359-002SS	MECHA BRACKET	2		
	46	E75896-006	FELT SPACER	2		
	47	---	CHANGER MECHA	1	SEE PAGE 2-5	
	48	VKS5503-001	GUIDE PIN	1		
	49	VYSA1R6-049	FELT SPACER	2		
	50	E407469-001SS	WIRE CLAMP	1		
△	51	QMF0007-1R6J1	FUSE	2		C,J
△		QMF51E2-1R2J1BS	FUSE	2		BS
△		QMF51E2-1R25	FUSE	2		A,EF,EN,G,GI,U,US,UT,VX
△	52	QMF0007-2R0J1	FUSE	1		C,J
△		QMF51E2-1R0J1	FUSE	1		A,EF,EN,G,GI,VX
△		QMF51E2-1R0J1BS	FUSE	1		BS
△		QMF51E2-2R0	FUSE	1		U,US,UT
△	53	QMF51E2-1R0J1	FUSE	1		U,US,UT
△	54	ETP1070-36EAJ	POWER TRANSFORMER	1		A,EF,EN,G,GI,VX
△		ETP1070-36EAJBS	POWER TRANSFORMER	1		BS
△		ETP1070-36FAJ	POWER TRANSFORMER	1		U,US,UT
△		ETP1070-36JAJ	POWER TRANSFORMER	1		C,J
	55	E65389-002	SPECIAL SCREW	4		
	56	EWS266-B908	SOCKET WIRE	1		
	57	E408393-002SS	SHIELD PLATE	1		
△	58	E309358-001SS	P.W.BOARD BRACKET	1		
△	59	QMP1D00-200H	POWER CORD	1		C,J
△		QMP25F0-244	POWER CORD	1		A
△		QMP3900-200	POWER CORD	1		EF,EN,G,GI,US,VX
△		QMP5530-0085BS	POWER CORD	1		BS
△	60	QMP7520-200	POWER CORD	1		U,UT
△		QHS3876-162	CORD STOPPER	1		A,BS,EF,EN,G,GI,U,US,UT,VX
△		QHS3876-163	CORD BUSHING	1		C,J
	61	E406969-221	LEAF SPRING	1		
	62	SBSG3014CC	SCREW	4		
	63	SPST2604Z	TAPPING SCREW	2		
	64	FSJC3007-001	HEAT SINK	1		
	65	E103012-008SS	REAR PANEL	1		J
		E103012-009SS	REAR PANEL	1		C
		E103012-010SS	REAR PANEL	1		U,US,UT
		E103012-011SS	REAR PANEL	1		BS,EF,EN,G,GI
		E103012-012SS	REAR PANEL	1		A
		E103012-013SS	REAR PANEL	1		VX
	66	E207356-223SS	REAR COVER	1		A,BS,EF,EN,G,GI,VX,U,US,UT
		E207356-002SM	REAR COVER	1		J,C
	67	E73273-003	SPECIAL SCREW	15		A,BS,C,EF,EN,G,GI,J,VX
		E73273-003	SPECIAL SCREW	17		U,US,UT
	68	E103014-002	METAL COVER	1		
	69	SDSG3006M	TAPPING SCREW	8		
	70	FSXP3017-001	VOLUME KNOB	1		U,US,UT
	71	VWF1209-40TTB	FLAT WIRE ASSY	1		
	72	VWF1207-45TTB	FLAT WIRE ASSY	1		
	73	VWF1216-40TTBX	FLAT WIRE ASSY	1		
	-	E307570-001	NUMBER LABEL	1		J
	-	E309384-009	RATING LABEL	2		UT

⚠	Item	Part Number	Part Name	Q'ty	Description	Area
	-	E406507-001	CAUTION LABEL	1		A,BS,C,EF,EN,G,GI,U,US,UT,VX
	-	E61029-005	NUMBER LABEL	1		A,BS,C,EF,EN,G,GI,U,US,UTVX
	-	E67132-T2R0	FUSE LABEL	1		U,US,UT
	-	E70028-001	APPROVAL LABEL	1		EN
	-	E70891-001	CLASS 1 LABEL	1		A,BS,EF,EN,G,GI,U,US,UT,VX
	-	E75040-054	GI LABEL	1		GI
	-	E75139-004	NAME LABEL	1		U,UT
	-	E75803-001	CAUTION LABEL	2		J
	-	E75804-001	CAUTION LABEL	2		C
	-	QZL1007-001	BEAB LABEL	1		BS
	-	QZL1031-101	LABEL	1		EF

General Exploded View and Parts List

Symbol No.

M	1	M	M
---	---	---	---

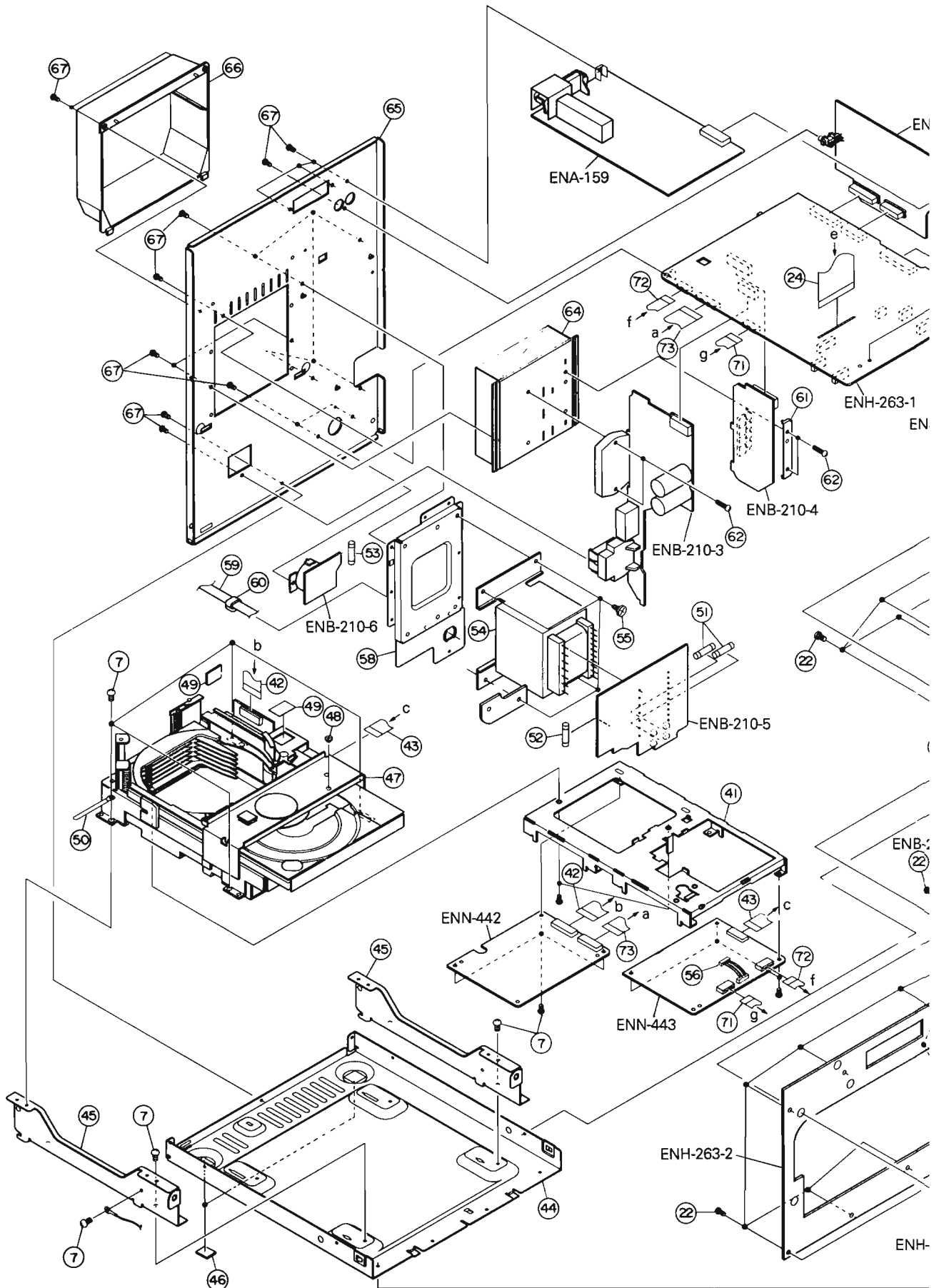

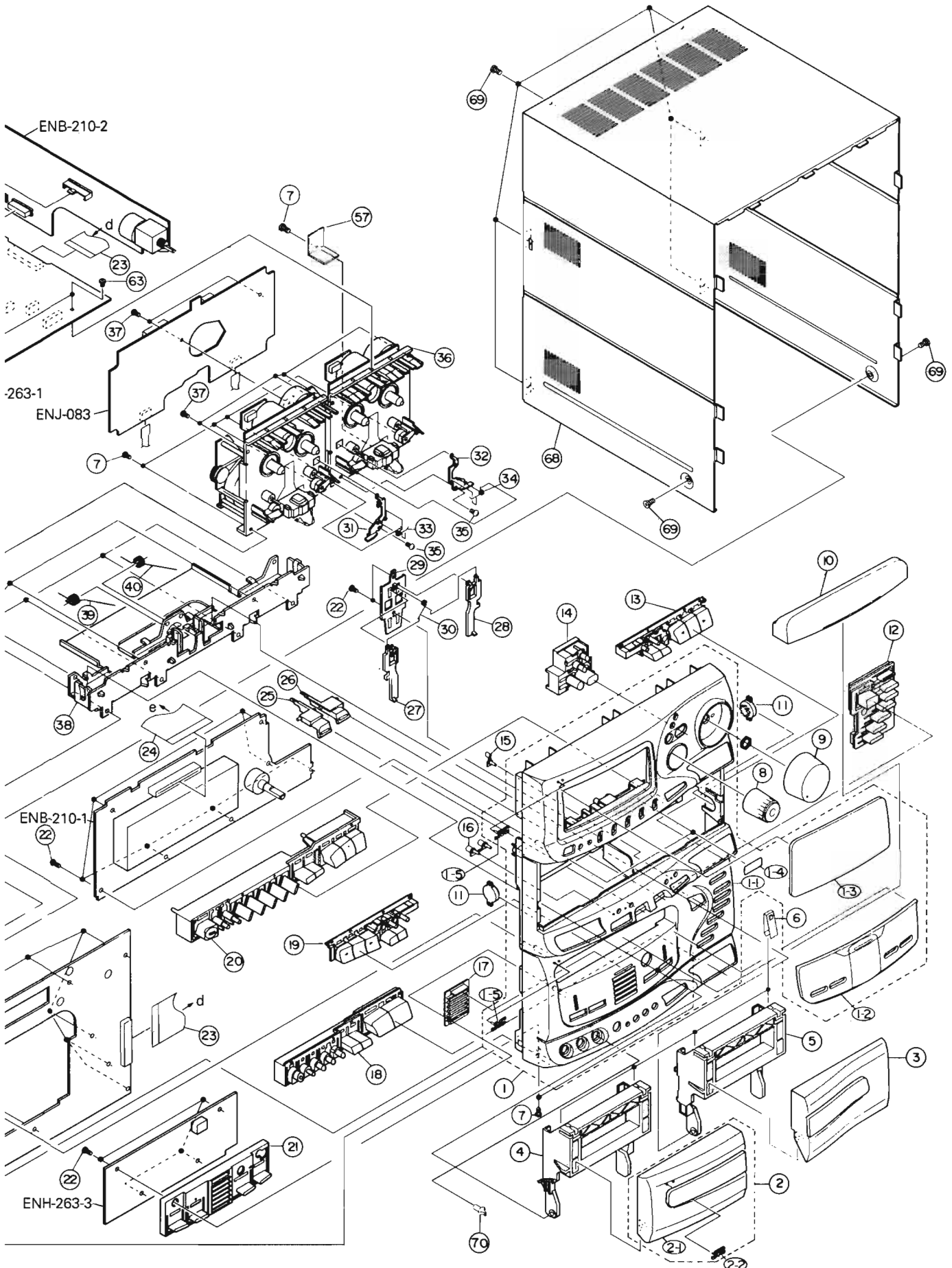

CD Changer Mechanism Ass'y and Parts List

Symbol No.

M	2	M
---	---	---

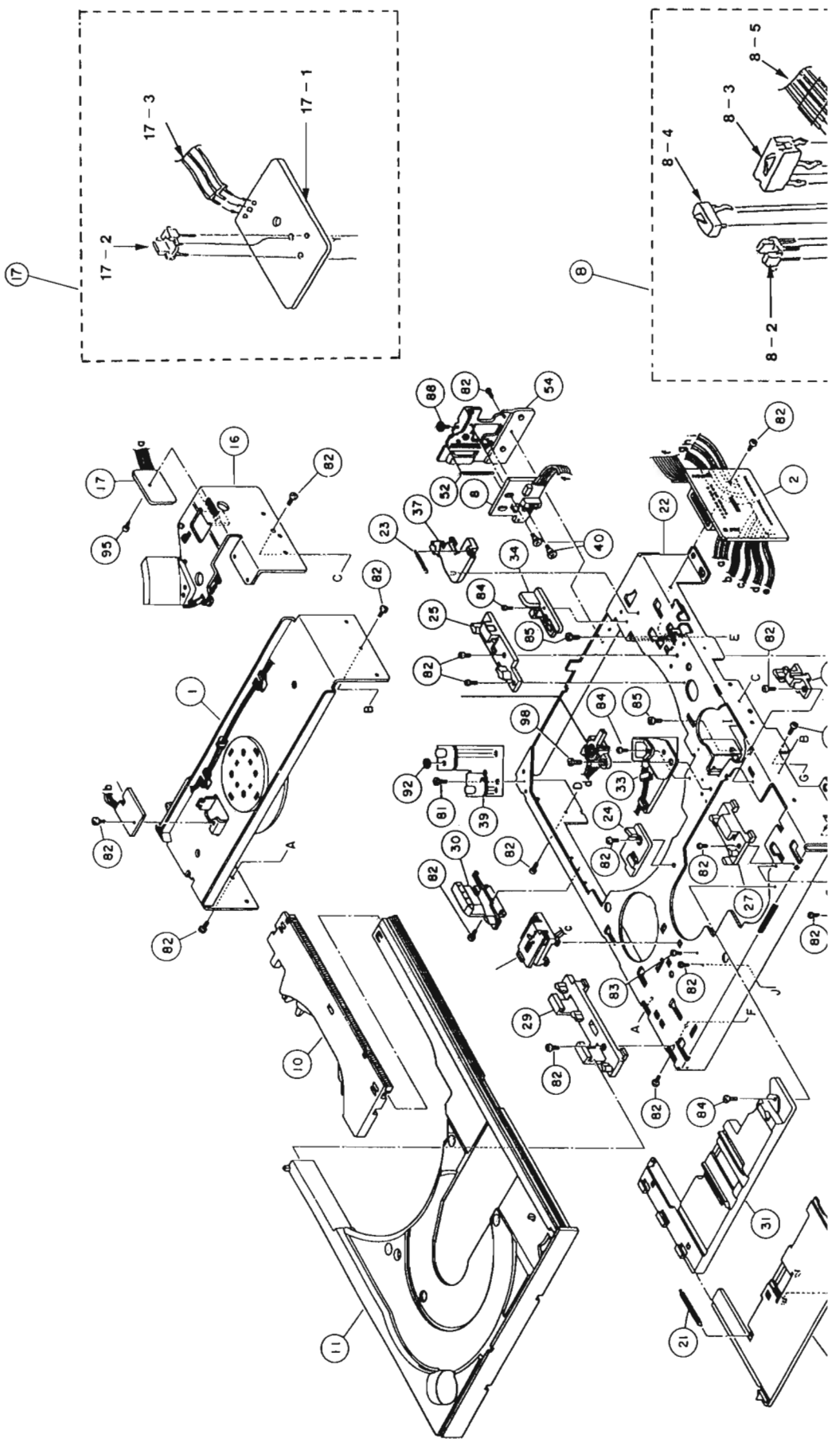

2 M M

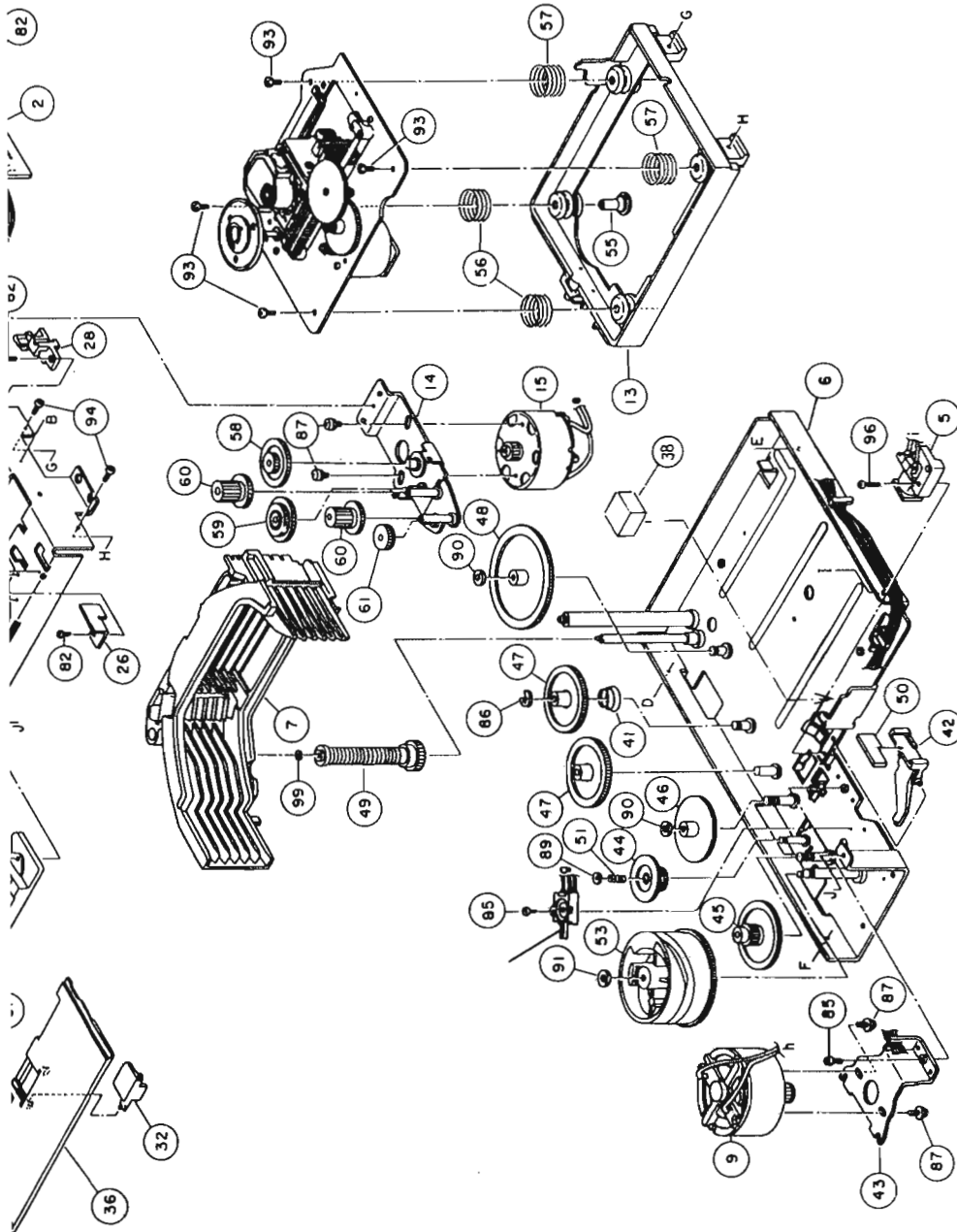
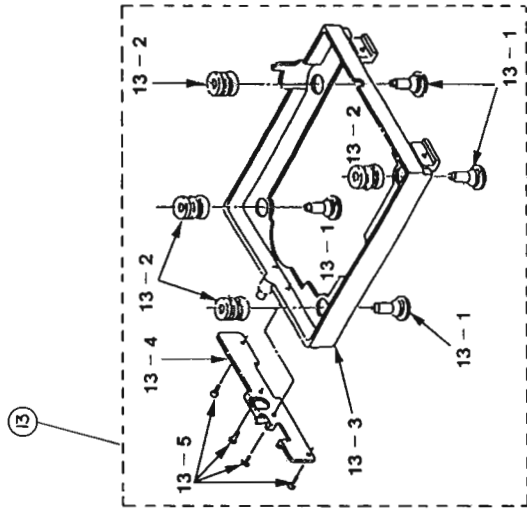
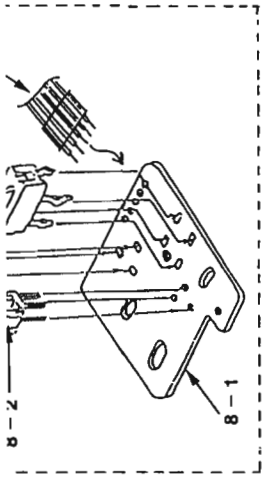

■ Parts List (CD Changer Mechanism Ass'y)

Symbol No.

M	2	M	M
---	---	---	---

△	Item	Part Number	Part Name	Q'ty	Description	Area
	1	300701307T	CLUMPER BKT ASSY	1		
	2	---	CONNECTOR PCB ASSY	1		
	2-1	30070119T	PRINTED BOARD	1		
	2-2	VMC0163-R18	CONNECT TERMINAL	1		
	2-3	68190503T	CARBON RESISTOR	2		
	2-4	30071016T	CONNECTOR WIRE ASSY	1		
	2-5	30071015T	CONNECTOR WIRE ASSY	1		
	3	---	CD MECH ASSY	1	SEE PAGE 2-7	
	5	300702303T	COIL ASSY	1		
	6	300702505T	GEAR CHASSIS	1		
	7	300702305T	DISC CASE ASSY	1		
	8	---	E.SENSOR PCB ASSY	1		
	8-1	30070250T	PRINTED BOARD	1		
	8-2	SPI-235-18	I.C(PHOTO-INTERRUPTOR)	1		
	8-3	64010401T	PUSH SWITCH	1		
	8-4	64010402T	PUSH SWITCH	1		
	8-5	30071013T	FLAT WIRE	1		
	9	300702302T	DC MOTOR ASSY	1		
	10	300706315T	LOADING PLATE ASSY	1		
	11	300706313T	DISC BASE ASSY	1		
	13	---	T.T BASE HOLDER ASSY	1		
	13-1	30070713T	RUBBER HOLDER	4		
	13-2	30070741T	RUBBER BUSHING	4		
	13-3	30070745T	BASE HOLDER	1		
	13-4	30070750T	PLATE	1		
	13-5	9P0720531T	TAPPING SCREW	4		
	14	300711501T	L.GEAR BKT ASSY	1		
	15	300711301T	L MOTOT ASSY	1		
	16	300711303T	GUIDE PLATE ASSY	1		
	17	---	L SENSOR PCB ASSY	1		
	17-1	30071116T	PRINTED BOARD	1		
	17-2	SPI-235-18	I.C(PHOTO-INTERRUPTOR)	1		
	17-3	30071018T	FLAT WIRE	1		
	21	30070117T	COIL SPRING	1		
	22	30070142T	CHASSIS BASE	1		
	23	30070144T	LEVER SPRING	1		
	24	30070165T	SPRING STOPPER	1		
	25	30070148T	BASE GUIDE	1		
	26	30070149T	BASE BRACKET	1		
	27	30070150T	BASE GUIDE	1		
	28	30070151T	BASE GUIDE	1		
	29	30070153T	BASE GUIDE	1		
	30	30070154T	BASE GUIDE	1		
	31	30070155T	COVER PLATE	1		
	32	30070156T	DISK STOPPER	1		
	33	30070157T	GUIDE STOPPER	1		
	34	30070158T	WIRE CLAMP	1		
	36	30070162T	COVER PLATE	1		
	37	30070163T	LOCK LEVER	1		
	38	30070265T	SPONGE CUSHION	1		

△	Item	Part Number	Part Name	Q'ty	Description	Area
	39	30070240T	GEAR BRACKET	1		
	40	19001204T	COLOR SCREW	2		
	41	19210707T	CLUTCH SPRING	1		
	42	30070257T	ADJUST LEVER	1		
	43	30070203T	MOTOR BRACKET	1		
	44	30070214T	ELEVATOR GEAR	1		
	45	30070215T	ELEVATOR GEAR	1		
	46	30070217T	ELEVATOR GEAR	1		
	47	30070218T	ELEVATOR GEAR	2		
	48	30070220T	ELEVATOR GEAR	1		
	49	30070221T	ELEVATOR GEAR	1		
	50	30070228T	CONTROL PLATE	1		
	51	30070232T	GEAR SPRING	1		
	52	30070233T	SENER SPRING	1		
	53	30070259T	ELEVATOR GEAR	1		
	54	30070266T	SENER BRACKET	1		
	56	30070755T	RUBBER SPRING	2		
	57	30070756T	RUBBER SPRING	2		
	58	30071103T	LOADING GEAR	1		
	59	30071104T	LOADING GEAR	1		
	60	30071105T	LOADING GEAR	2		
	61	30071106T	LOADING GEAR	1		
	81	9B1320041T	TAPPING SCREW	1		
	82	9P0420041T	SCREW	18		
	83	9P0420051T	SCREW	1		
	84	9P0420061T	TAPPING SCREW	4		
	85	9C2020301T	SPECIAL SCREW	3		
	86	9E0100252T	'E' WASHER	1		
	87	9P0226031T	SCREW	4		
	88	9P1720061T	SCREW	1		
	89	9W0250080T	POLY WASHER	1		
	90	9W0250110T	WASHER	2		
	91	9W0250130T	POLY WASHER	1		
	92	9W0650220T	POLY WASHER	4		
	93	9B1220041T	TAPPING SCREW	3		
	94	9P0720061T	TAPPING SCREW	1		
	95	9C0320353T	SCREW	2		
	96	9P0420081T	TAPPING SCREW	1		
	97	9C2020301T	TAPPING SCREW	1		
	98	9P0426051T	TAPPING SCREW	1		
	99	9W0613010T	WASHER	1		

CD Mechanism Ass'y and Parts List

Symbol No.

M	3	M	M
---	---	---	---

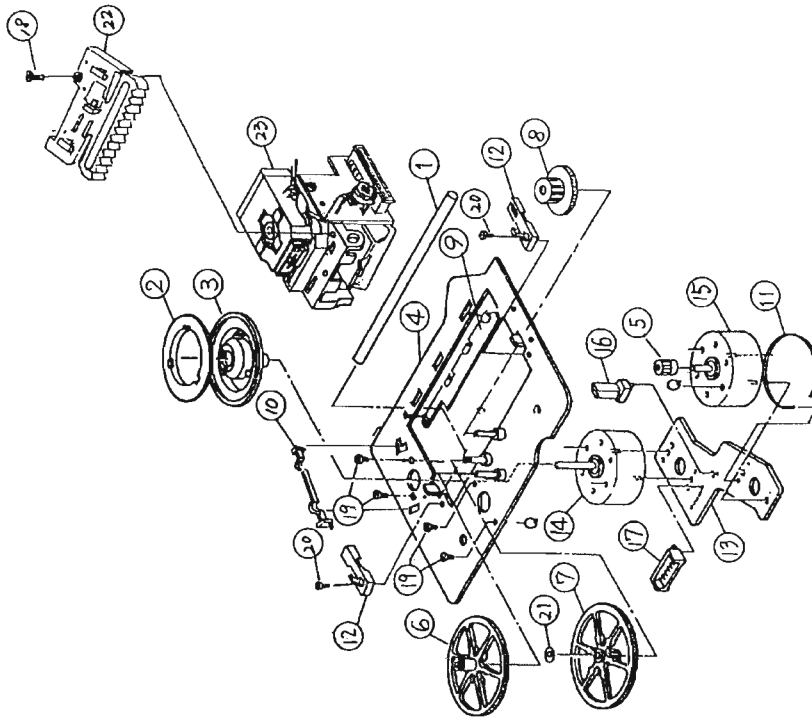

■ Parts List (CD Mechanism Ass'y)

Symbol No.

M	3	M	M
---	---	---	---

Item	Part Number	Part Name	Q'ty	Description	Area
1	30020712T	GUIDE SHAFT	1		
2	30050713T	LOCK RING	1		
3	30070760T	TURNTABLE	1		
4	300707502T	MECHA BASE	1		
5	30070726T	CD GEAR	1		
6	30070727T	CD GEAR	1		
7	30070728T	CD GEAR	1		
8	30070729T	CD GEAR	1		
9	30070730T	STOPPER	1		
10	30070739T	TENSION ARM	1		
11	30070746T	EARTH SPRING	1		
12	30070764T	SHAFT CLAMP	2		
13	30070751T	PRINTED BOARD	1		
14	60020902T	SPINDLE MOTOR	1		
15	60020903T	GEAR MOTOR	1		
16	640101195T	LEAF SWITCH	1		
17	68020264T	CONNECT TERMINAL	1		
18	9B1220061T	SCREW	1		
19	9C0120253T	TAPPING SCREW	4		
20	9P0420051T	TAPPING SCREW	2		
21	9W0640070T	WASHER	1		
22	E307746-001	CD RACK	1		
23	OPTIMA-65	OPTICAL PICK-UP	1		

■ Parts List (Cassette Mechanism Ass'y)

Symbol No.

M	4	M	M
---	---	---	---

△	Item	Part Number	Part Name	Q'ty	Description	Area
	1	VKM3775-00A	GUIDE BRACKET	1		
	2	SDSF2608Z	SCREW	1		
	3	MSI5U2LWA-SA1	DC MOTOR	1		
	3-1	MSI-5U2LWA	DC MOTOR	1		
	3-2	VKR4632-003MM	MOTOR PULLEY	1		
	4	SPSP2603Z	WOOD SCREW	1		
	5	VKS5327-005MM	LOCK PLATE	1		
	6	WDL163525-4	WASHER	1		
	7	VKR4631-005MM	IDLER PULLEY	1		
	8	MSN5D257A-SA1	DC MOTOR	1		
	8-1	MSN-5D257A	DC MOTOR	1		
	8-2	VKS5433-001	ACTUATER MOTOR GEAR	1		
	9	MMN-6F4RA38	DC MOTOR	1		
	10	SDSR2004Z	SCREW	1		
	11	VMC0234-R08	CONNECT TERMINAL	1		
	12	VKS5430-00CMM	F.F/REW.ARM	1		
	13	VKS5432-001	REEL MOTOR GEAR	1		
	14	SDST2612Z	SCREW	1		
	15	VKS3616-00A	CAM SWITCH	1		
	16	DN6851-HI	I.C(M)	1		
	17	VKS3630-001MM	I.C.PROTECTOR	1		
	18	MXS00220MVL0	CASSETTE SWITCH	1		
	19	VMC0234-R11	CONNECT TERMINAL	1		
	19	VMC0234-R14	CONNECT TERMINAL	1		
	20	VKB3001-064	DRIVE BELT	1		
	20	VKB3001-065	DRIVE BELT	1		
	21	VKF3184-00H	FLYWHEEL	1		
	22	VKF3186-00H	FLYWHEEL	1		
	23	VKS2224-002	CONTROL CAM	1		
	24	VKS5454-001	ACTUATER GEAR	1		
	25	VKS5455-001	ACTUATER GEAR	1		
	26	VKS3627-001	PINCH ROLLER LEVER	1		
	27	VKP4229-00B	PINCH ROLLER	1		
	28	VKS1134-00B	CHASSIS BASE	1		
	29	VKW5045-003	PINCH ROLLER SPRING	1		
	30	VKP4227-00B	PINCH ROLLER	1		
	31	VKS5428-00B	REEL DISK	1		
	32	VKW5043-001	TENSION SPRING	1		
	33	VKS3617-002	REEL DISK	1		
	34	VKZ4705-102	SCREW	1		
	35	VKY4670-001	SPRING	1		
	36	VKZ4705-101	SCREW	1		
	37	VKZ4708-001	SPECIAL SCREW	1		
	38	VKM3632-001	HEAD BASE	1		
	39	VKW5046-003	PINCH ROLLER SPRING	1		
	40	VKS3682-00BMM	H.MOUNT ASS'Y	1		
	40	VKS3701-00AMM	H.MOUNT ASS'Y	1		
	40-1	VKW5126-001	HEAD SPRING	1		
	40-2	VKS3670-001	CONNECT GEAR	1		
	40-3	VKS3671-001	HEAD COVER	1		
	40-4	VKZ4730-001	SPECIAL SCREW	1		

Cassette Mechanism Ass'y and Parts List

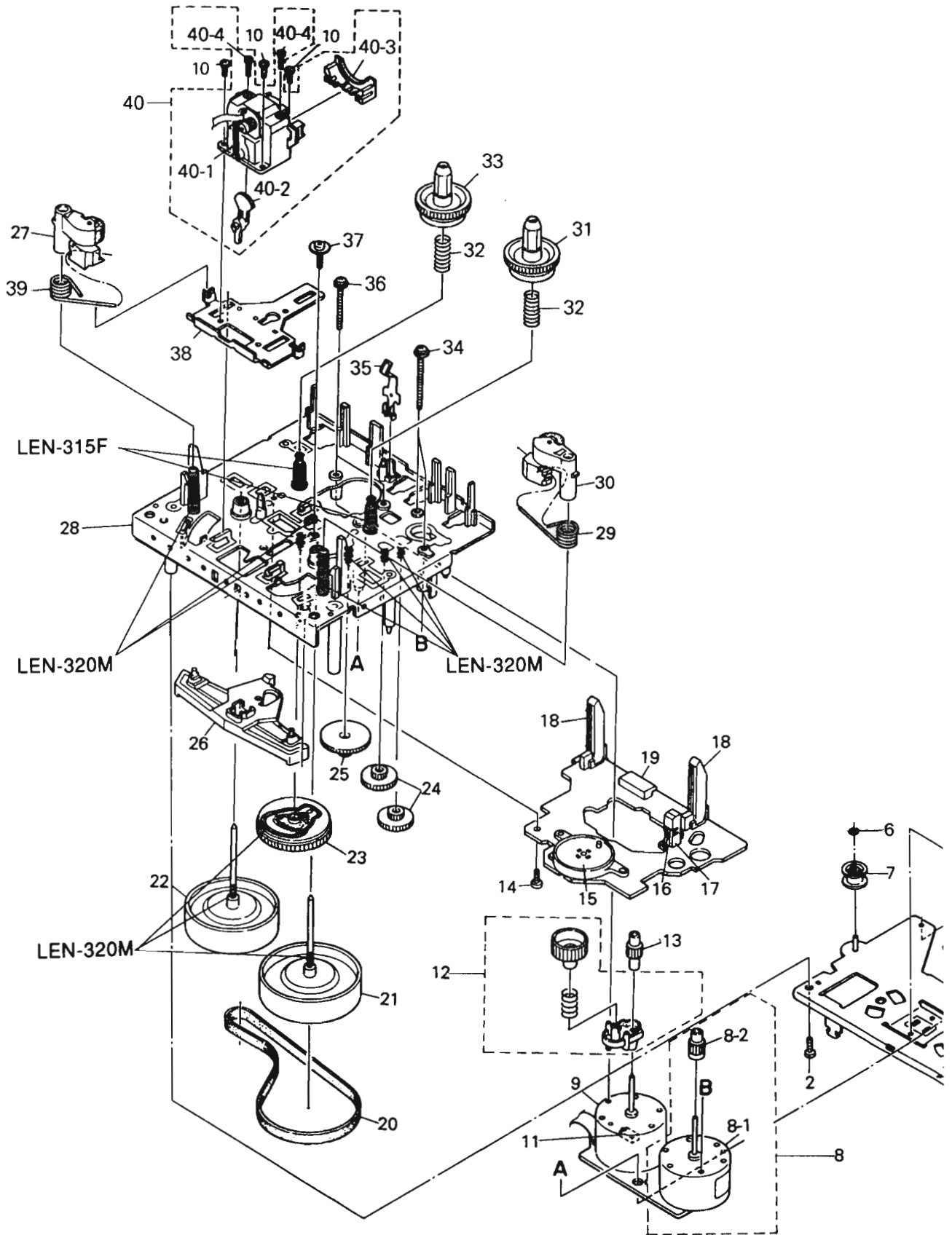

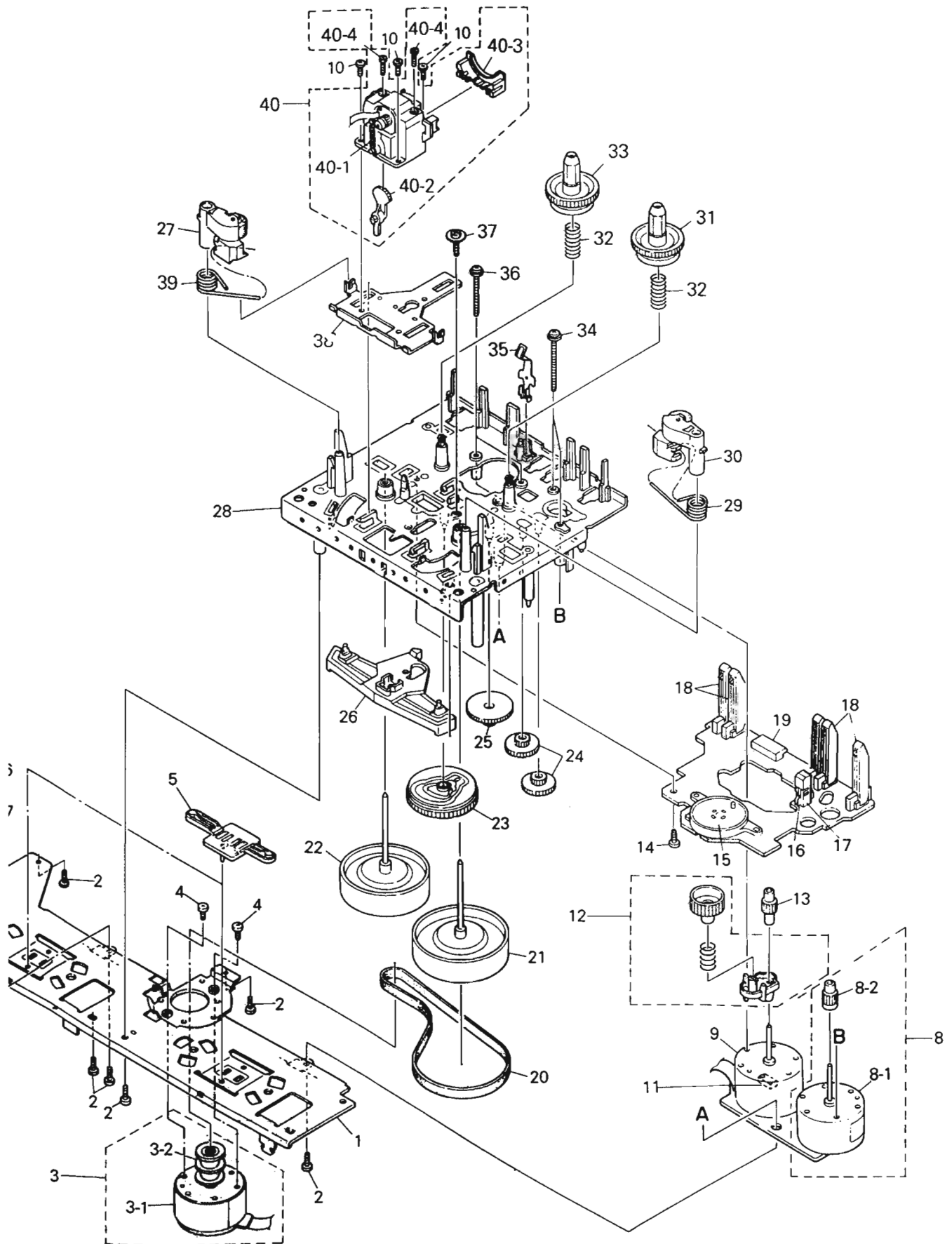

Printed Circuit Board Ass'y and Parts List

■ ENN-442 **A** CD Changer MechanizmControl PC Board Ass'y

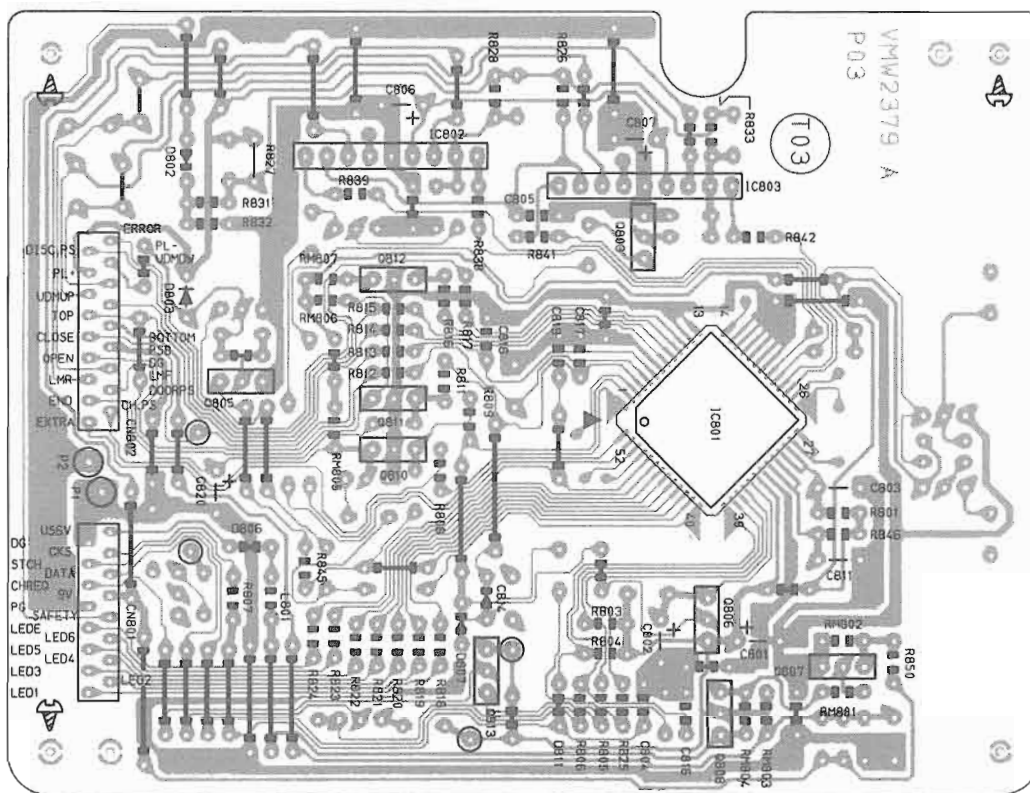

TRANSISTORS

ITEM	PART NUMBER	DESCRIPTION	AREA
Q805	2SD1302	SI. TRANSIST MATSUSHITA	
Q806	DTA143ES	DIGITAL TRA ROHM	
Q807	2SC1740S(R,S)	SI. TRANSIST ROHM	
Q808	2SA1317	SI. TRANSIST SANYO	
Q810	2SA1317	SI. TRANSIST SANYO	
Q811	2SA1317	SI. TRANSIST SANYO	
Q812	2SA1317	SI. TRANSIST SANYO	
Q813	2SC1740S(R,S)	SI. TRANSIST ROHM	

△ : SAFETY PARTS

CAPACITORS

ITEM	PART NUMBER	DESCRIPTION	AREA
C801	QEK51AM-107	100MF 10V AL E.CAPAC	
C802	QEK51EM-475	4.7MF 25V AL E.CAPAC	
C803	QFV81HJ-104	0.1MF 50V THIN FILM	
C804	QCBB1HK-102Y	1000PF 50V CER.CAPACI	
C805	QCVB1CM-103Y	0.01MF 16V CER.CAPACI	
C806	QEK51CM-476	47MF 16V AL E.CAPAC	
C807	QEK51CM-476	47MF 16V AL E.CAPAC	
C811	QFV81HJ-104	0.1MF 50V THIN FILM	
C816	QCBB1HK-102Y	1000PF 50V CER.CAPACI	
C817	QCVB1CM-103Y	0.01MF 16V CER.CAPACI	
C818	QCFB1HZ-104Y	0.1MF 50V CER.CAPACI	
C819	QCVB1CM-103Y	0.01MF 16V CER.CAPACI	
C820	QEK51HM-225G	2.2MF 50V AL E.CAPAC	

△ : SAFETY PARTS

I.C.S

ITEM	PART NUMBER	DESCRIPTION	AREA
IC801	UPD65612GC-088	I.C(M) 0050	
IC802	TA8409S	I.C(MONO-AN TOSHIBA	
IC803	TA8409S	I.C(MONO-AN TOSHIBA	

△ : SAFETY PARTS

DIODES

ITEM	PART NUMBER	DESCRIPTION	AREA
D802	1SS254	DIODE	
D803	11E2	SI. DIODE NIHONINTER	
D806	1SS254	DIODE	
D807	1SS254	DIODE	
D808	1SS254	DIODE	

△ : SAFETY PARTS

RESISTORS

ITEM	PART NUMBER	DESCRIPTION	AREA
R801	QRD161J-103	10K 1/6W CARBON RES	
R803	QRD167J-223	22K 1/6W CARBON RES	
R804	QRD167J-223	22K 1/6W CARBON RES	
R805	QRD161J-471	470 1/6W CARBON RES	
R806	QRD161J-471	470 1/6W CARBON RES	
R807	QRD161J-471	470 1/6W CARBON RES	
R808	QRD161J-102	1K 1/6W CARBON RES	
R809	QRD161J-681	680 1/6W CARBON RES	
R811	QRD161J-681	680 1/6W CARBON RES	
R812	QRD161J-102	1K 1/6W CARBON RES	
R813	QRD161J-102	1K 1/6W CARBON RES	
R814	QRD161J-102	1K 1/6W CARBON RES	
R815	QRD161J-102	1K 1/6W CARBON RES	
R816	QRD161J-681	680 1/6W CARBON RES	
R817	QRD161J-102	1K 1/6W CARBON RES	
R818	QRD167J-223	22K 1/6W CARBON RES	
R819	QRD167J-223	22K 1/6W CARBON RES	
R820	QRD167J-223	22K 1/6W CARBON RES	
R821	QRD167J-223	22K 1/6W CARBON RES	
R822	QRD167J-223	22K 1/6W CARBON RES	

△ : SAFETY PARTS

RESISTORS

ITEM	PART NUMBER	DESCRIPTION	AREA
R823	QRD167J-223	22K 1/6W CARBON RES	
R824	QRD167J-223	22K 1/6W CARBON RES	
R825	QRD161J-471	470 1/6W CARBON RES	
R826	QRD161J-181	180 1/6W CARBON RES	
R827	QRZ0076-100X	10 1/4W FUSIBLE RE	
R828	QRD161J-102	1K 1/6W CARBON RES	
R831	QRD167J-682	6.8K 1/6W CARBON RES	
R832	QRD161J-472	4.7K 1/6W CARBON RES	
R833	QRD161J-102	1K 1/6W CARBON RES	
R838	QRD161J-102	1K 1/6W CARBON RES	
R839	QRD161J-102	1K 1/6W CARBON RES	
R841	QRD161J-102	1K 1/6W CARBON RES	
R842	QRD161J-102	1K 1/6W CARBON RES	
R845	QRD161J-102	1K 1/6W CARBON RES	
R846	QRD161J-103	10K 1/6W CARBON RES	
R850	QRD167J-822	8.2K 1/6W CARBON RES	
RM801	QRD161J-103	10K 1/6W CARBON RES	
RM802	QRD167J-152	1.5K 1/6W CARBON RES	
RM803	QRD167J-151	150 1/6W CARBON RES	
RM804	QRD161J-473	47K 1/6W CARBON RES	

△ : SAFETY PARTS

RESISTORS

ITEM	PART NUMBER	DESCRIPTION	AREA
RM805	QRD161J-224	220K 1/6W CARBON RES	
RM806	QRD161J-224	220K 1/6W CARBON RES	
RM807	QRD161J-104	100K 1/6W CARBON RES	
RM812	QRD161J-473	47K 1/6W CARBON RES	

△ : SAFETY PARTS

OTHERS

ITEM	PART NUMBER	DESCRIPTION	AREA
L801	VMW2379-003X	PRINTED BOA	
CN801	EQL4004-100	INDUCTOR	
CN802	VMC0161-R16	CONNECT TER	
SP801	VMC0161-R18	CONNECT TER	
	VYH7237-003	I.C.COVER	

△ : SAFETY PARTS

■ ENN-443 □ CD Servo & Low Pass Filter PC Board Ass'y

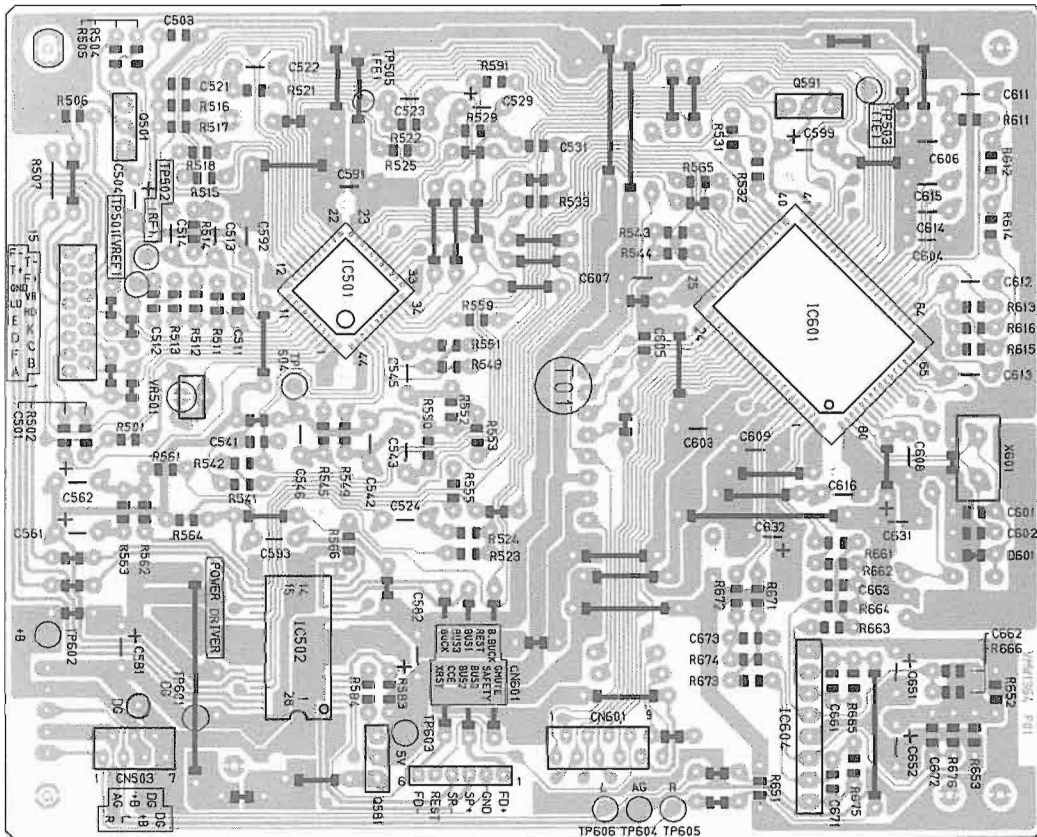

TRANSISTORS

ITEM	PART NUMBER	DESCRIPTION	AREA
Q501	2SA952(L,K)	SI.TRANSIST NEC	
Q581	2SA952(L,K)	SI.TRANSIST NEC	
Q591	2SA933S(RS)	SI.TRANSIST	

△ : SAFETY PARTS

I.C.S

ITEM	PART NUMBER	DESCRIPTION	AREA
IC501	TA8191F	I.C.(MONO-AN TOSHIBA	
IC502	BA6398FP	I.C.(MONO-AN ROHM	
IC601	TC9284BF	I.C.(M) TOSHIBA	
IC604	NJM4580L-S	I.C.(MONO-AN 0050	

△ : SAFETY PARTS

CAPACITORS

Δ	ITEM	PART NUMBER	DESCRIPTION	AREA
	C501	QCBB1HK-821Y	820PF 50V CER.CAPACI	
	C503	QCVB1CM-103Y	0.01MF 16V CER.CAPACI	
	C504	QETB1EM-106	10MF 25V AL E.CAPAC	
	C511	QCSB1HK-3R9	3.9PF 50V CER.CAPACI	
	C512	QCSB1HJ-270	27PF 50V CERAMIC	
	C513	QFLB1HJ-104	0.1MF 50V MYLAR CAPA	
	C514	QFN81HJ-472	4700PF 50V MYLAR CAPA	
	C521	QCBB1HK-331Y	330PF 50V CER.CAPACI	
	C522	QFLB1HJ-473	0.047MF 50V MYLAR CAPA	
	C523	QFV81HJ-154	0.15MF 50V THIN FILM	
	C524	QENC1HM-475Z	4.7MF 50V NP E.CAPAC	
	C529	QETB1AM-336	33MF 10V AL E.CAPAC	
	C531	QCVB1CM-822Y	8200PF 16V CER.CAPACI	
	C541	QCBB1HK-101Y	100PF 50V CER.CAPACI	
	C542	QFLB1HJ-103	0.01MF 50V MYLAR CAPA	
	C543	QFLB1HJ-393	0.039MF 50V MYLAR CAPA	
	C545	QENC1HM-105Z	1MF 50V NP E.CAPAC	
	C546	QFLB1HJ-223	0.022MF 50V MYLAR CAPA	
	C561	QETB1AM-476	47MF 10V E.CAPACITO	
	C562	QETB1HM-475E	4.7MF 50V E.CAPACITO	
	C581	QETB1AM-477	470MF 10V E.CAPACITO	
	C582	QEK51CM-476	47MF 16V AL E.CAPAC	
	C591	QCZ0205-155	1.5MF 25V C.CAPACITO	
	C592	QCZ0205-155	1.5MF 25V C.CAPACITO	
	C593	QCC21EM-104	0.1MF 25V CER.CAPACI	
	C599	QEK51AM-107	100MF 10V AL E.CAPAC	
	C601	QCSB1HJ-220	22PF 50V CER.CAPACI	
	C602	QCSB1HJ-220	22PF 50V CER.CAPACI	
	C603	QFV81HJ-104	0.1MF 50V THIN FILM	
	C604	QCC21EM-104	0.1MF 25V CER.CAPACI	
	C605	QCVB1CM-103Y	0.01MF 16V CER.CAPACI	
	C606	QCC21EM-473	0.047MF 25V CER.CAPACI	
	C607	QFV81HJ-104	0.1MF 50V THIN FILM	
	C608	QCC21EM-473	0.047MF 25V CER.CAPACI	
	C609	QFV81HJ-104	0.1MF 50V THIN FILM	
	C611	QCS21HJ-101A	100PF 50V CER.CAPACI	
	C612	QFLB1HJ-103	0.01MF 50V MYLAR CAPA	
	C613	QFLB1HJ-103	0.01MF 50V MYLAR CAPA	
	C614	QFN31HJ-332Z	3300PF 50V MYLAR CAPA	
	C615	QFN31HJ-332Z	3300PF 50V MYLAR CAPA	
	C616	QCC21EM-103	0.01MF 25V CER.CAPACI	
	C631	QEK51AM-107	100MF 10V AL E.CAPAC	
	C632	QER50JM-107	100MF 6.3V AL E.CAPAC	
	C651	QEK51AM-107	100MF 10V AL E.CAPAC	
	C652	QEK51CM-226	22MF 16V AL E.CAPAC	
	C661	QCBB1HK-101Y	100PF 50V CER.CAPACI	
	C662	QCBB1HK-101Y	100PF 50V CER.CAPACI	
	C663	QCSB1HJ-270	27PF 50V CERAMIC	
	C671	QCBB1HK-101Y	100PF 50V CER.CAPACI	
	C672	QCBB1HK-101Y	100PF 50V CER.CAPACI	
	C673	QCSB1HJ-270	27PF 50V CERAMIC	

Δ : SAFETY PARTS

OTHERS

Δ	ITEM	PART NUMBER	DESCRIPTION	AREA
		EMW10477-004	PRINTED BOA	
		VMM1364-002X	PRINTED BOA	
	X601	CSA16.93MXZ040T	CERAMIC RES	
	CN501	EMV7144-015R	CONNECT TER	
	CN502	EMV5109-006A	CONNECT TER	
	CN503	VMC0161-R07	CONNECT TER	
	CN601	VMC0161-R09	CONNECT TER	
	SP501	VYH7237-004	I.C.COVER	
	SP502	VYH7653-003	I.C.PROTECT	
	SP601	VYH7237-002	I.C.COVER	

Δ : SAFETY PARTS

RESISTORS

Δ	ITEM	PART NUMBER	DESCRIPTION	AREA
	R501	QRD161J-124	120K 1/6W CARBON RES	
	R502	QRD161J-103	10K 1/6W CARBON RES	
	R504	QRD161J-202	2K 1/6W CARBON RES	
	R505	QRD161J-100	10 1/6W CARBON RES	
	R506	QRD161J-101	100 1/6W CARBON RES	
	R507	QRD161J-120	12 1/6W CARBON RES	
	R511	QRD161J-183	18K 1/6W CARBON RES	
	R512	QRD161J-392	3.9K 1/6W CARBON RES	
	R513	QRD167J-332	3.3K 1/6W CARBON RES	
	R514	QRD161J-472	4.7K 1/6W CARBON RES	
	R515	QRD161J-103	10K 1/6W CARBON RES	
	R516	QRD161J-103	10K 1/6W CARBON RES	
	R517	QRD161J-202	2K 1/6W CARBON RES	
	R518	QRD161J-335YT	3.3M 1/6W CARBON RES	
	R521	QRD167J-154	150K 1/6W CARBON RES	
	R522	QRD161J-392	3.9K 1/6W CARBON RES	
	R523	QRD161J-472	4.7K 1/6W CARBON RES	
	R524	QRD161J-331	330 1/6W CARBON RES	
	R525	QRD161J-472	4.7K 1/6W CARBON RES	
	R529	QRD167J-562	5.6K 1/6W CARBON RES	
	R531	QRD161J-473	47K 1/6W CARBON RES	
	R532	QRD161J-104	100K 1/6W CARBON RES	
	R533	QRD167J-153	15K 1/6W CARBON RES	
	R541	QRD161J-123	12K 1/6W CARBON RES	
	R542	QRD167J-332	3.3K 1/6W CARBON RES	
	R543	QRD161J-473	47K 1/6W CARBON RES	
	R544	QRD167J-223	22K 1/6W CARBON RES	
	R545	QRD161J-103	10K 1/6W CARBON RES	
	R548	QRD167J-153	15K 1/6W CARBON RES	
	R549	QRD161J-821	820 1/6W CARBON RES	
	R550	QRD161J-104	100K 1/6W CARBON RES	
	R551	QRD167J-223	22K 1/6W CARBON RES	
	R552	QRD167J-562	5.6K 1/6W CARBON RES	
	R553	QRD161J-821	820 1/6W CARBON RES	
	R555	QRD161J-392	3.9K 1/6W CARBON RES	
	R559	QRD161J-125	1.2M 1/6W CARBON RES	
	R561	QRD167J-562	5.6K 1/6W CARBON RES	
	R562	QRD161J-102	1K 1/6W CARBON RES	
	R563	QRD167J-152	1.5K 1/6W CARBON RES	
	R564	QRD167J-332	3.3K 1/6W CARBON RES	
	R565	QRD161J-683	68K 1/6W CARBON RES	
	R566	QRD161J-273	27K 1/6W CARBON RES	
	R583	QRD161J-101	100 1/6W CARBON RES	
	R584	QRD161J-331	330 1/6W CARBON RES	
	R591	QRD161J-473	47K 1/6W CARBON RES	
	R611	QRD161J-102	1K 1/6W CARBON RES	
	R612	QRD161J-103	10K 1/6W CARBON RES	
	R613	QRD161J-224	220K 1/6W CARBON RES	
	R614	QRD161J-473	47K 1/6W CARBON RES	
	R615	QRD161J-225	2.2M 1/6W CARBON RES	
	R616	QRD161J-333	33K 1/6W CARBON RES	
	R651	QRD161J-820	82 1/6W CARBON RES	
	R652	QRD161J-473	47K 1/6W CARBON RES	
	R653	QRD161J-473	47K 1/6W CARBON RES	
	R661	QRD161J-473	47K 1/6W CARBON RES	
	R662	QRD161J-473	47K 1/6W CARBON RES	
	R663	QRD161J-473	47K 1/6W CARBON RES	
	R664	QRD161J-473	47K 1/6W CARBON RES	
	R665	QRD167J-223	22K 1/6W CARBON RES	
	R666	QRD167J-223	22K 1/6W CARBON RES	
	R671	QRD161J-473	47K 1/6W CARBON RES	
	R672	QRD161J-473	47K 1/6W CARBON RES	
	R673	QRD161J-473	47K 1/6W CARBON RES	
	R674	QRD161J-473	47K 1/6W CARBON RES	
	R675	QRD167J-223	22K 1/6W CARBON RES	
	R676	QRD167J-223	22K 1/6W CARBON RES	
	VR501	QVPA601-154A	150K TRIMMER RE	

Δ : SAFETY PARTS

DIODES

Δ	ITEM	PART NUMBER	DESCRIPTION	AREA
	D121	1SS133	SI. DIODE ROHM	
	D122	1SS133	SI. DIODE ROHM	
	D123	1SS133	SI. DIODE ROHM	
	D124	1SS133	SI. DIODE ROHM	
	D125	1SS133	SI. DIODE ROHM	BS
	D125	1SS133	SI. DIODE ROHM	EF
	D125	1SS133	SI. DIODE ROHM	EN
	D125	1SS133	SI. DIODE ROHM	G
	D125	1SS133	SI. DIODE ROHM	GI
	D125	1SS133	SI. DIODE ROHM	VX
	D126	1SS133	SI. DIODE ROHM	
	D127	1SS133	SI. DIODE ROHM	BS
	D127	1SS133	SI. DIODE ROHM	EF
	D127	1SS133	SI. DIODE ROHM	EN
	D127	1SS133	SI. DIODE ROHM	G
	D127	1SS133	SI. DIODE ROHM	GI
	D127	1SS133	SI. DIODE ROHM	VX
	D128	1SS133	SI. DIODE ROHM	BS
	D128	1SS133	SI. DIODE ROHM	EF
	D128	1SS133	SI. DIODE ROHM	EN
	D128	1SS133	SI. DIODE ROHM	G
	D128	1SS133	SI. DIODE ROHM	GI
	D128	1SS133	SI. DIODE ROHM	VX
	D129	1SS133	SI. DIODE ROHM	
	D130	1SS133	SI. DIODE ROHM	
	D141	1SS133	SI. DIODE ROHM	
	D182	MTZ5.1JC	ZENER DIODE ROHM	

Δ : SAFETY PARTS

CAPACITORS

Δ	ITEM	PART NUMBER	DESCRIPTION	AREA
	C151	QCS21HJ-181A	180PF 50V CER. CAPACI	G
	C151	QCS21HJ-181A	180PF 50V CER. CAPACI	GI
	C151	QCS21HJ-181A	180PF 50V CER. CAPACI	VX
	C152	QCS21HJ-181A	180PF 50V CER. CAPACI	BS
	C152	QCS21HJ-181A	180PF 50V CER. CAPACI	EF
	C152	QCS21HJ-181A	180PF 50V CER. CAPACI	EN
	C152	QCS21HJ-181A	180PF 50V CER. CAPACI	G
	C152	QCS21HJ-181A	180PF 50V CER. CAPACI	GI
	C152	QCS21HJ-181A	180PF 50V CER. CAPACI	VX
	C153	QCY31HK-102Z	1000PF 50V CER. CAPACI	A
	C153	QCY31HK-102Z	1000PF 50V CER. CAPACI	C
	C153	QCY31HK-102Z	1000PF 50V CER. CAPACI	J
	C153	QCY31HK-102Z	1000PF 50V CER. CAPACI	U
	C153	QCY31HK-102Z	1000PF 50V CER. CAPACI	US
	C153	QCY31HK-102Z	1000PF 50V CER. CAPACI	UT
	C153	QCY31HK-821Z	820PF 50V CER. CAPACI	BS
	C153	QCY31HK-821Z	820PF 50V CER. CAPACI	EF
	C153	QCY31HK-821Z	820PF 50V CER. CAPACI	EN
	C153	QCY31HK-821Z	820PF 50V CER. CAPACI	G
	C153	QCY31HK-821Z	820PF 50V CER. CAPACI	GI
	C153	QCY31HK-821Z	820PF 50V CER. CAPACI	VX
	C154	QCY31HK-472Z	4700PF 50V CER. CAPACI	
	C155	QETB1EM-476	47MF 25V AL E. CAPAC	
	C156	QCHB1EZ-223	0.022MF 25V CER. CAPACI	
	C157	QCZ0202-155	1.5MF 25V CER. RESIST	
	C158	QETB1HM-106	10MF 50V E. CAPACITO	
	C159	QFLB1HJ-333	0.033MF 50V MYLAR CAPA	
	C160	QFLB1HJ-333	0.033MF 50V MYLAR CAPA	
	C161	QETB1HM-225	2.2MF 50V AL E. CAPAC	
	C162	QETB1HM-225	2.2MF 50V AL E. CAPAC	
	C163	QETB1HM-225	2.2MF 50V AL E. CAPAC	
	C164	QETB1HM-225	2.2MF 50V AL E. CAPAC	
	C166	QCC21EM-473	0.047MF 25V CER. CAPACI	
	C168	QCC21EM-473	0.047MF 25V CER. CAPACI	
	C169	QFVB1HJ-274	0.27MF 50V T. FILM CAP	
	C171	QCSB1HJ-470	47PF 50V CER. CAPACI	
	C179	QCSB1HK-101Y	100PF 50V CER. CAPACI	
	C183	QCF21HP-223A	0.022MF 50V CER. CAPACI	
	C184	QETB1CM-227	220MF 16V AL E. CAPAC	
	C185	QETB1CM-477M	470MF 16V E. CAPACITO	
	C186	QETB1HM-475E	4.7MF 50V E. CAPACITO	

Δ : SAFETY PARTS

CAPACITORS

Δ	ITEM	PART NUMBER	DESCRIPTION	AREA
	C101	QCF21HP-103A	0.01MF 50V CER. CAPACI	
	C102	QETB1EM-476	47MF 25V AL E. CAPAC	BS
	C102	QETB1EM-476	47MF 25V AL E. CAPAC	EF
	C102	QETB1EM-476	47MF 25V AL E. CAPAC	EN
	C102	QETB1EM-476	47MF 25V AL E. CAPAC	G
	C102	QETB1EM-476	47MF 25V AL E. CAPAC	GI
	C102	QETB1EM-476	47MF 25V AL E. CAPAC	VX
	C103	QCF21HP-223A	0.022MF 50V CER. CAPACI	
	C104	QCF21HP-223A	0.022MF 50V CER. CAPACI	
	C105	QCHB1EZ-223	0.022MF 25V CER. CAPACI	
	C107	QCHB1EZ-223	0.022MF 25V CER. CAPACI	
	C111	QCHB1EZ-223	0.022MF 25V CER. CAPACI	
	C112	QCT30CH-120Y	12PF 50V CER. CAPACI	
	C113	QCHB1EZ-223	0.022MF 25V CER. CAPACI	BS
	C113	QCHB1EZ-223	0.022MF 25V CER. CAPACI	EF
	C113	QCHB1EZ-223	0.022MF 25V CER. CAPACI	EN
	C113	QCHB1EZ-223	0.022MF 25V CER. CAPACI	G
	C113	QCHB1EZ-223	0.022MF 25V CER. CAPACI	GI
	C113	QCHB1EZ-223	0.022MF 25V CER. CAPACI	VX
	C114	QCC21EM-473	0.047MF 25V CER. CAPACI	
	C121	QCS21HJ-180A	18PF 50V CER. CAPACI	
	C122	QCS21HJ-180A	18PF 50V CER. CAPACI	
	C123	QCC21EM-473	0.047MF 25V CER. CAPACI	
	C124	QCZ0202-155	1.5MF 25V CER. RESIST	
	C125	QCF21HP-223A	0.022MF 50V CER. CAPACI	
	C126	QCSB1HK-101Y	100PF 50V CER. CAPACI	
	C127	QCSB1HK-101Y	100PF 50V CER. CAPACI	
	C128	QENB1HM-474	0.47MF 50V NP E. CAPAC	
	C129	QCY31HK-102Z	1000PF 50V CER. CAPACI	
	C130	QETB1CM-227	220MF 16V AL E. CAPAC	
	C134	QCSB1HK-5R6Y	5.6PF 50V CER. CAPACI	BS
	C134	QCSB1HK-5R6Y	5.6PF 50V CER. CAPACI	EF
	C134	QCSB1HK-5R6Y	5.6PF 50V CER. CAPACI	EN
	C134	QCSB1HK-5R6Y	5.6PF 50V CER. CAPACI	G
	C134	QCSB1HK-5R6Y	5.6PF 50V CER. CAPACI	GI
	C134	QCSB1HK-5R6Y	5.6PF 50V CER. CAPACI	VX
	C135	QCSB1HJ-150Y	15PF 50V CER. CAPACI	BS
	C135	QCSB1HJ-150Y	15PF 50V CER. CAPACI	EF
	C135	QCSB1HJ-150Y	15PF 50V CER. CAPACI	EN
	C135	QCSB1HJ-150Y	15PF 50V CER. CAPACI	G
	C135	QCSB1HJ-150Y	15PF 50V CER. CAPACI	GI
	C135	QCSB1HJ-150Y	15PF 50V CER. CAPACI	VX
	C141	QFLB1HJ-473	0.047MF 50V MYLAR CAPA	
	C142	QETB1HM-106	10MF 50V E. CAPACITO	
	C143	QCF21HP-223A	0.022MF 50V CER. CAPACI	
	C144	QCC21EM-473	0.047MF 25V CER. CAPACI	
	C145	QETB1HM-475E	4.7MF 50V E. CAPACITO	
	C146	QETB1HM-106	10MF 50V E. CAPACITO	
	C147	QETB1HM-105	1MF 50V AL E. CAPAC	
	C148	QETB1HM-474	0.47MF 50V ELECTRO	
	C149	QETB1HM-105	1MF 50V AL E. CAPAC	
	C150	QETC1HM-225ZN	2.2MF 50V AL E. CAPAC	BS
	C151	QCS21HJ-181A	180PF 50V CER. CAPACI	EF
	C151	QCS21HJ-181A	180PF 50V CER. CAPACI	EN

Δ : SAFETY PARTS

RESISTORS

Δ	ITEM	PART NUMBER	DESCRIPTION	AREA
	R102	QRD167J-332	3.3K 1/6W CARBON RES	
	R103	QRD161J-221	220 1/6W CARBON RES	
	R104	QRD167J-272	2.7K 1/6W CARBON RES	
	R105	QRD161J-391	390 1/6W CARBON RES	
	R106	QRD161J-102	1K 1/6W CARBON RES	
	R107	QRD161J-681	680 1/6W CARBON RES	
	R108	QRD167J-332	3.3K 1/6W CARBON RES	
	R109	QRD161J-221	220 1/6W CARBON RES	
	R110	QRD161J-472	4.7K 1/6W CARBON RES	BS
	R110	QRD161J-472	4.7K 1/6W CARBON RES	EF
	R110	QRD161J-472	4.7K 1/6W CARBON RES	EN
	R110	QRD161J-472	4.7K 1/6W CARBON RES	G
	R110	QRD161J-472	4.7K 1/6W CARBON RES	GI
	R110	QRD161J-472	4.7K 1/6W CARBON RES	VX
	R111	QRD161J-472	4.7K 1/6W CARBON RES	BS
	R111	QRD161J-472	4.7K 1/6W CARBON RES	EF
	R111	QRD161J-472	4.7K 1/6W CARBON RES	EN
	R111	QRD161J-472	4.7K 1/6W CARBON RES	G
	R111	QRD161J-472	4.7K 1/6W CARBON RES	GI
	R111	QRD161J-472	4.7K 1/6W CARBON RES	VX
	R112	QRD161J-472	4.7K 1/6W CARBON RES	BS
	R112	QRD161J-472	4.7K 1/6W CARBON RES	EF
	R112	QRD161J-472	4.7K 1/6W CARBON RES	EN
	R112	QRD161J-472	4.7K 1/6W CARBON RES	G
	R112	QRD161J-472	4.7K 1/6W CARBON RES	GI
	R112	QRD161J-472	4.7K 1/6W CARBON RES	VX
	R113	QRD161J-103	10K 1/6W CARBON RES	BS
	R113	QRD161J-103	10K 1/6W CARBON RES	EF
	R113	QRD161J-103	10K 1/6W CARBON RES	EN
	R113	QRD161J-103	10K 1/6W CARBON RES	G
	R113	QRD161J-103	10K 1/6W CARBON RES	GI
	R113	QRD161J-103	10K 1/6W CARBON RES	VX
	R114	QRD161J-103	10K 1/6W CARBON RES	
	R115	QRD161J-104	100K 1/6W CARBON RES	
	R116	QRD161J-222	2.2K 1/6W CARBON RES	
	R122	QRD161J-473	4.7K 1/6W CARBON RES	
	R122	QRD161J-472	4.7K 1/6W CARBON RES	
	R123	QRD167J-562	5.6K 1/6W CARBON RES	
	R124	QRD161J-222	2.2K 1/6W CARBON RES	
	R125	QRD161J-222	2.2K 1/6W CARBON RES	

Δ : SAFETY PARTS

■ ENJ-083 □ Deck Amp.,EQ & NR PC Board Ass'y

Note : ENJ-083 □ varies according to the areas employed. See note (2) when placing an order.

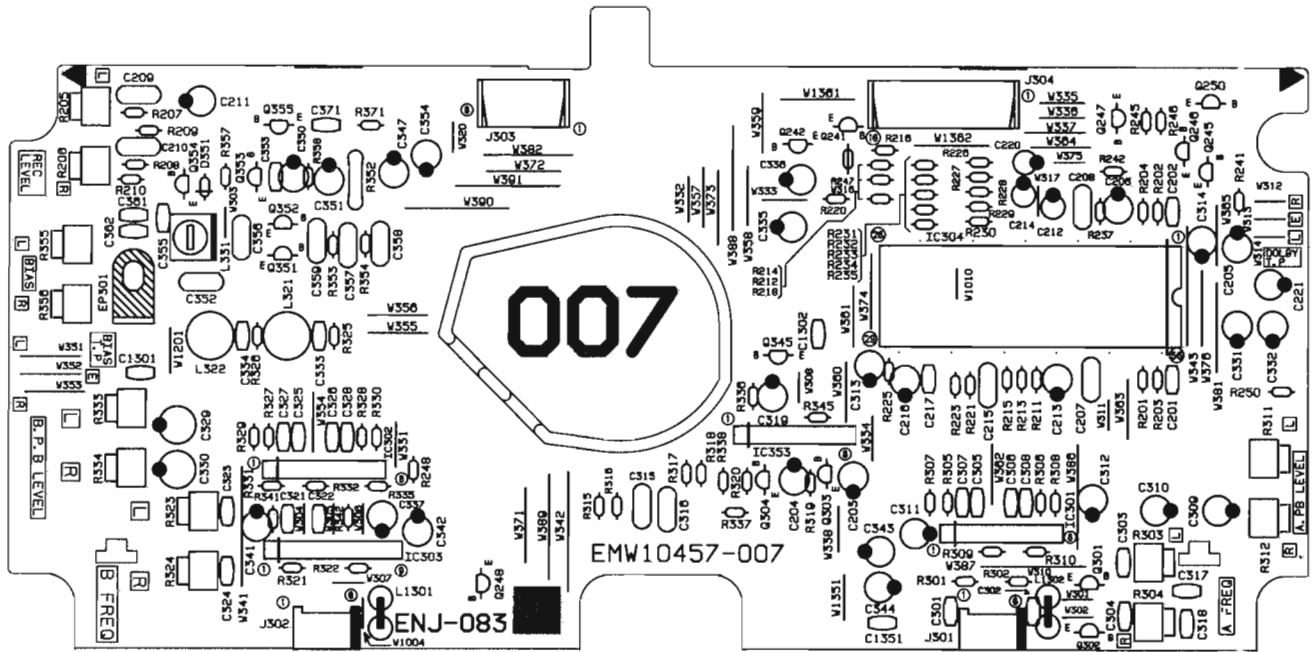

Note(2)

PC Board Ass'y	Designated Areas
ENJ-083 D	Austraria, U.S.A., Canada Singapore, Taiwan, Other Countries
ENJ-083 E	the U.K., Eastern Europe Scandinavia, Germany, Italy Continental Europe

I.C.S

Δ	ITEM	PART NUMBER	DESCRIPTION	AREA
	IC301	NJM4580LD	I.C(MONO-AN DAINICHI	
	IC302	NJM4580LD	I.C(MONO-AN DAINICHI	
	IC303	UPC1330HA	I.C(MONO-AN NEC	
	IC304	HA1271NT	I.C(MONO-AN HITACHI	
	IC353	BA8221AN	I.C(MONO-AN ROHM	

Δ :SAFETY PARTS

TRANSISTORS

Δ	ITEM	PART NUMBER	DESCRIPTION	AREA
	Q245	2SD2144S(VW)	SI.TRANSIST ROHM	
	Q246	2SD2144S(VW)	SI.TRANSIST ROHM	
	Q247	DTA144ES	DIGITAL TRA ROHM	
	Q248	DTC144ES	DIGITAL TRA ROHM	
	Q303	2SC1740S(R,S)	SI.TRANSIST ROHM	
	Q304	2SC1740S(R,S)	SI.TRANSIST ROHM	
	Q345	DTC144ES	DIGITAL TRA ROHM	
	Q351	2SC3311A(Q,R)	SI.TRANSIST MATSUSHITA	
	Q352	2SC3311A(Q,R)	SI.TRANSIST MATSUSHITA	
	Q353	2SC3311A(Q,R)	SI.TRANSIST MATSUSHITA	
	Q354	2SC3311A(Q,R)	SI.TRANSIST MATSUSHITA	BS
	Q354	2SC3311A(Q,R)	SI.TRANSIST MATSUSHITA	EF
	Q354	2SC3311A(Q,R)	SI.TRANSIST MATSUSHITA	EN
	Q354	2SC3311A(Q,R)	SI.TRANSIST MATSUSHITA	G
	Q354	2SC3311A(Q,R)	SI.TRANSIST MATSUSHITA	GI
	Q354	2SC3311A(Q,R)	SI.TRANSIST MATSUSHITA	VX
	Q355	DTA144ES	DIGITAL TRA ROHM	BS
	Q355	DTA144ES	DIGITAL TRA ROHM	EF
	Q355	DTA144ES	DIGITAL TRA ROHM	EN
	Q355	DTA144ES	DIGITAL TRA ROHM	G
	Q355	DTA144ES	DIGITAL TRA ROHM	GI
	Q355	DTA144ES	DIGITAL TRA ROHM	VX

Δ :SAFETY PARTS

DIODES

Δ	ITEM	PART NUMBER	DESCRIPTION	AREA
	D351	1SS119	SI. DIODE	BS
	D351	1SS119	SI. DIODE	EF
	D351	1SS119	SI. DIODE	EN
	D351	1SS119	SI. DIODE	G
	D351	1SS119	SI. DIODE	GI
	D351	1SS119	SI. DIODE	VX

Δ SAFETY PARTS

CAPACITORS

Δ	ITEM	PART NUMBER	DESCRIPTION	AREA
	C201	QCXB1CM-472Y	4700PF 16V CER. CAPACI	
	C202	QCXB1CM-472Y	4700PF 16V CER. CAPACI	
	C203	QETB1HM-105	1MF 50V AL E. CAPAC	
	C204	QETB1HM-105	1MF 50V AL E. CAPAC	
	C205	QETB1EM-106	10MF 25V AL E. CAPAC	
	C206	QETB1EM-106	10MF 25V AL E. CAPAC	
	C207	QFV81HJ-104	0.1MF 50V THIN FILM	
	C208	QFV81HJ-104	0.1MF 50V THIN FILM	
	C211	QETB1HM-105	1MF 50V AL E. CAPAC	
	C212	QEK51HM-105G	1MF 50V AL E. CAPAC	
	C213	QER61HM-334Z	0.33MF 50V AL E. CAPAC	
	C214	QER61HM-334Z	0.33MF 50V AL E. CAPAC	
	C215	QFLB1HJ-472	4700PF 50V MYLAR CAPA	
	C216	QETB1HM-474	0.47MF 50V ELECTRO	
	C217	QCXB1CM-222Y	2200PF 16V CER. CAPACI	
	C220	QEK51HM-225G	2.2MF 50V AL E. CAPAC	
	C221	QETB1HM-475E	4.7MF 50V E. CAPACITO	
	C301	QCBB1HK-821Y	820PF 50V CER. CAPACI	
	C302	QCBB1HK-821Y	820PF 50V CER. CAPACI	
	C303	QCBB1HK-331Y	330PF 50V CER. CAPACI	
	C304	QCBB1HK-331Y	330PF 50V CER. CAPACI	
	C305	QCBB1HK-101Y	100PF 50V CER. CAPACI	
	C306	QCBB1HK-101Y	100PF 50V CER. CAPACI	
	C307	QCVB1CM-822Y	8200PF 16V CER. CAPACI	
	C308	QCVB1CM-822Y	8200PF 16V CER. CAPACI	
	C309	QETB1AM-107	100MF 10V AL E. CAPAC	
	C310	QETB1AM-107	100MF 10V AL E. CAPAC	
	C311	QETB1HM-105	1MF 50V AL E. CAPAC	
	C312	QETB1HM-105	1MF 50V AL E. CAPAC	
	C313	QETB1AM-107	100MF 10V AL E. CAPAC	
	C314	QETB1AM-107	100MF 10V AL E. CAPAC	
	C315	QFV81HJ-473	0.047MF 50V THIN FILM	
	C316	QFV81HJ-473	0.047MF 50V THIN FILM	
	C319	QETB1AM-476	47MF 10V E. CAPACITO	
	C321	QCXB1CM-122	1200PF 16V POLYPROPY.	
	C322	QCXB1CM-122	1200PF 16V POLYPROPY.	
	C323	QCBB1HK-331Y	330PF 50V CER. CAPACI	
	C324	QCBB1HK-331Y	330PF 50V CER. CAPACI	
	C325	QCBB1HK-101Y	100PF 50V CER. CAPACI	
	C326	QCBB1HK-101Y	100PF 50V CER. CAPACI	
	C327	QCVB1CM-822Y	8200PF 16V CER. CAPACI	
	C328	QCVB1CM-822Y	8200PF 16V CER. CAPACI	
	C329	QEK51CM-107	100MF 16V E. CAPACITO	
	C330	QEK51CM-107	100MF 16V E. CAPACITO	
	C331	QETB1HM-105	1MF 50V AL E. CAPAC	
	C332	QETB1HM-105	1MF 50V AL E. CAPAC	
	C333	QCBB1HK-101Y	100PF 50V CER. CAPACI	
	C334	QCBB1HK-101Y	100PF 50V CER. CAPACI	
	C335	QETB1EM-106	10MF 25V AL E. CAPAC	
	C336	QETB1EM-106	10MF 25V AL E. CAPAC	
	C337	QEK51CM-226	22MF 16V AL E. CAPAC	
	C341	QER51HM-105G	1MF 50V AL E. CAPAC	
	C342	QER51HM-105G	1MF 50V AL E. CAPAC	
	C343	QETB1AM-107	100MF 10V AL E. CAPAC	
	C344	QETB1AM-107	100MF 10V AL E. CAPAC	
	C347	QETB1AM-107	100MF 10V AL E. CAPAC	
	C350	QETB1HM-105	1MF 50V AL E. CAPAC	
	C351	QETB1AM-107	100MF 10V AL E. CAPAC	
	C352	QFP31HG-562	5600PF 50V POLYPROPY.	
	C353	QCVB1CM-103Y	0.01MF 16V CER. CAPACI	
	C354	QETB1AM-107	100MF 10V AL E. CAPAC	
	C355	QCBB1HK-471Y	470PF 50V CER. CAPACI	BS
	C355	QCBB1HK-471Y	470PF 50V CER. CAPACI	EF
	C355	QCBB1HK-471Y	470PF 50V CER. CAPACI	EN
	C355	QCBB1HK-471Y	470PF 50V CER. CAPACI	G
	C355	QCBB1HK-471Y	470PF 50V CER. CAPACI	GI
	C355	QCBB1HK-471Y	470PF 50V CER. CAPACI	VX
	C356	QFLB1HJ-153	0.015MF 50V MYLAR CAPA	
	C357	QFLB1HJ-332	3300PF 50V MYLAR CAPA	
	C358	QFLB1HJ-332	3300PF 50V MYLAR CAPA	
	C359	QFLB1HJ-682	6800PF 50V MYLAR CAPA	
	C361	QCBB1HK-101Y	100PF 50V CER. CAPACI	
	C362	QCBB1HK-101Y	100PF 50V CER. CAPACI	
	C371	QCHB1EZ-223	0.022MF 25V CER. CAPACI	BS
	C371	QCHB1EZ-223	0.022MF 25V CER. CAPACI	EF
	C371	QCHB1EZ-223	0.022MF 25V CER. CAPACI	EN
	C371	QCHB1EZ-223	0.022MF 25V CER. CAPACI	G
	C371	QCHB1EZ-223	0.022MF 25V CER. CAPACI	GI
	C371	QCHB1EZ-223	0.022MF 25V CER. CAPACI	VX
	C1301	QCBB1HK-102Y	1000PF 50V CER. CAPACI	BS

Δ SAFETY PARTS

CAPACITORS

Δ	ITEM	PART NUMBER	DESCRIPTION	AREA
	C1301	QCBB1HK-102Y	1000PF 50V CER. CAPACI	EF
	C1301	QCBB1HK-102Y	1000PF 50V CER. CAPACI	EN
	C1301	QCBB1HK-102Y	1000PF 50V CER. CAPACI	G
	C1301	QCBB1HK-102Y	1000PF 50V CER. CAPACI	GI
	C1301	QCBB1HK-102Y	1000PF 50V CER. CAPACI	VX
	C1302	QCBB1HK-102Y	1000PF 50V CER. CAPACI	BS
	C1302	QCBB1HK-102Y	1000PF 50V CER. CAPACI	EF
	C1302	QCBB1HK-102Y	1000PF 50V CER. CAPACI	EN
	C1302	QCBB1HK-102Y	1000PF 50V CER. CAPACI	G
	C1302	QCBB1HK-102Y	1000PF 50V CER. CAPACI	GI
	C1302	QCBB1HK-102Y	1000PF 50V CER. CAPACI	VX

Δ SAFETY PARTS

RESISTORS

Δ	ITEM	PART NUMBER	DESCRIPTION	AREA
	R201	QRD167J-153	15K 1/6W CARBON RES	
	R202	QRD167J-153	15K 1/6W CARBON RES	
	R203	QRD161J-123	12K 1/6W CARBON RES	
	R204	QRD161J-123	12K 1/6W CARBON RES	
	R205	QVPA603-503A	50K VARIABLE R	
	R206	QVPA603-503A	50K VARIABLE R	
	R209	QRD167J-153	15K 1/6W CARBON RES	
	R210	QRD167J-153	15K 1/6W CARBON RES	
	R211	QRD161J-823	82K 1/6W CARBON RES	
	R212	QRD167J-562	5.6K 1/6W CARBON RES	
	R213	QRD161J-203	20K 1/6W CARBON RES	
	R214	QRD167J-682	6.8K 1/6W CARBON RES	
	R215	QRD167J-153	15K 1/6W CARBON RES	
	R216	QRD167J-332	3.3K 1/6W CARBON RES	
	R218	QRD161J-472	4.7K 1/6W CARBON RES	
	R220	QRD161J-243	24K 1/6W CARBON RES	
	R221	QRD161J-103	10K 1/6W CARBON RES	
	R223	QRD161J-183	18K 1/6W CARBON RES	
	R225	QRD161J-184	180K 1/6W CARBON RES	
	R226	QRD167J-223	22K 1/6W CARBON RES	
	R227	QRD167J-223	22K 1/6W CARBON RES	
	R228	QRD167J-223	22K 1/6W CARBON RES	
	R229	QRD167J-223	22K 1/6W CARBON RES	
	R230	QRD167J-223	22K 1/6W CARBON RES	
	R231	QRD167J-223	22K 1/6W CARBON RES	
	R232	QRD167J-223	22K 1/6W CARBON RES	
	R233	QRD167J-223	22K 1/6W CARBON RES	
	R234	QRD167J-223	22K 1/6W CARBON RES	
	R235	QRD167J-223	22K 1/6W CARBON RES	
	R237	QRD161J-183	18K 1/6W CARBON RES	
	R241	QRD161J-392	3.9K 1/6W CARBON RES	
	R242	QRD161J-392	3.9K 1/6W CARBON RES	
	R245	QRD161J-472	4.7K 1/6W CARBON RES	
	R246	QRD161J-472	4.7K 1/6W CARBON RES	
	R248	QRD161J-103	10K 1/6W CARBON RES	
	R301	QRD167J-334	330K 1/6W CARBON RES	
	R302	QRD167J-334	330K 1/6W CARBON RES	
	R303	QVPA603-104A	100K TRIMMER RE	
	R304	QVPA603-104A	100K TRIMMER RE	
	R305	QRD167J-334	330K 1/6W CARBON RES	
	R306	QRD167J-334	330K 1/6W CARBON RES	
	R307	QRD167J-223	22K 1/6W CARBON RES	
	R308	QRD167J-223	22K 1/6W CARBON RES	
	R309	QRD161J-391	390 1/6W CARBON RES	
	R310	QRD161J-391	390 1/6W CARBON RES	
	R311	QVPA603-501A	500 TRIMMER RE	
	R312	QVPA603-501A	500 TRIMMER RE	
	R315	QRD161J-564	560K 1/6W CARBON RES	
	R316	QRD161J-564	560K 1/6W CARBON RES	
	R317	QRD161J-103	10K 1/6W CARBON RES	
	R318	QRD161J-103	10K 1/6W CARBON RES	
	R319	QRD167J-332	3.3K 1/6W CARBON RES	
	R320	QRD167J-332	3.3K 1/6W CARBON RES	
	R321	QRD161J-100	10 1/6W CARBON RES	
	R322	QRD161J-100	10 1/6W CARBON RES	
	R323	QVPA603-104A	100K TRIMMER RE	
	R324	QVPA603-104A	100K TRIMMER RE	
	R325	QRD167J-153	15K 1/6W CARBON RES	
	R326	QRD167J-153	15K 1/6W CARBON RES	
	R327	QRD167J-334	330K 1/6W CARBON RES	
	R328	QRD167J-334	330K 1/6W CARBON RES	
	R329	QRD161J-203	20K 1/6W CARBON RES	
	R330	QRD161J-203	20K 1/6W CARBON RES	
	R331	QRD167J-151	150 1/6W CARBON RES	
	R332	QRD167J-151	150 1/6W CARBON RES	
	R333	QVPA603-501A	500 TRIMMER RE	
	R334	QVPA603-501A	500 TRIMMER RE	
	R335	QRD161J-101	100 1/6W CARBON RES	
	R336	QRD161J-105	1M 1/6W CARBON RES	
	R337	QRD161J-133Y	13K 1/6W CARBON RES	
	R338	QRD161J-133Y	13K 1/6W CARBON RES	
	R341	QRD167J-334	330K 1/6W CARBON RES	
	R342	QRD167J-334	330K 1/6W CARBON RES	
	R345	QRD161J-103	10K 1/6W CARBON RES	
	R352	QRD14CJ-6R8SX	6.8 1/4W UNF. CARBON	

Δ SAFETY PARTS

RESISTORS

Δ	ITEM	PART NUMBER	DESCRIPTION		AREA
	R353	QRD161J-393	39K	1/6W CARBON RES	
	R354	QRD161J-393	39K	1/6W CARBON RES	
	R355	QVPA603-104A	100K	TRIMMER RE	
	R356	QVPA603-104A	100K	TRIMMER RE	
	R357	QRD161J-102	1K	1/6W CARBON RES	BS
	R357	QRD161J-102	1K	1/6W CARBON RES	EF
	R357	QRD161J-102	1K	1/6W CARBON RES	EN
	R357	QRD161J-102	1K	1/6W CARBON RES	G
	R357	QRD161J-102	1K	1/6W CARBON RES	GI
	R357	QRD161J-102	1K	1/6W CARBON RES	VX
	R358	QRD161J-103	10K	1/6W CARBON RES	
	R371	QRD161J-102	1K	1/6W CARBON RES	BS
	R371	QRD161J-102	1K	1/6W CARBON RES	EF
	R371	QRD161J-102	1K	1/6W CARBON RES	EN
	R371	QRD161J-102	1K	1/6W CARBON RES	G
	R371	QRD161J-102	1K	1/6W CARBON RES	GI
	R371	QRD161J-102	1K	1/6W CARBON RES	VX

Δ : SAFETY PARTS

OTHERS

Δ	ITEM	PART NUMBER	DESCRIPTION		AREA
	J301	EMV10457-006	PRINTED BOA		
	J301	EMV7155-106R	CONNECT TER		
	J302	EMV7155-106R	CONNECT TER		
	J303	EMV5132-008R	CONNECT TER		
	J304	EMV5132-016R	CONNECT TER		
	L321	EQL2106-223	INDUCTOR		
	L322	EQL2106-223	INDUCTOR		
	L331	ENZ6002-012	OSCILLATOR		
	EP301	EMZ4002-001Z	EARTH PLATE		BS
	EP301	EMZ4002-001Z	EARTH PLATE		EF
	EP301	EMZ4002-001Z	EARTH PLATE		EN
	EP301	EMZ4002-001Z	EARTH PLATE		G
	EP301	EMZ4002-001Z	EARTH PLATE		GI
	EP301	EMZ4002-001Z	EARTH PLATE		VX
	L1301	ENZ8101-007	INDUCTOR		BS
	L1301	ENZ8101-007	INDUCTOR		EF
	L1301	ENZ8101-007	INDUCTOR		EN
	L1301	ENZ8101-007	INDUCTOR		G
	L1301	ENZ8101-007	INDUCTOR		GI
	L1301	ENZ8101-007	INDUCTOR		VX
	L1302	ENZ8101-007	INDUCTOR		BS
	L1302	ENZ8101-007	INDUCTOR		EF
	L1302	ENZ8101-007	INDUCTOR		EN
	L1302	ENZ8101-007	INDUCTOR		G
	L1302	ENZ8101-007	INDUCTOR		GI
	L1302	ENZ8101-007	INDUCTOR		VX

Δ : SAFETY PARTS

■ ENH-263 □ Indicator, Key & Deck / Amp. Control PC Board Ass'y

Note : ENH-263 □ varies according to the areas employed. See note (3) when placing an order.

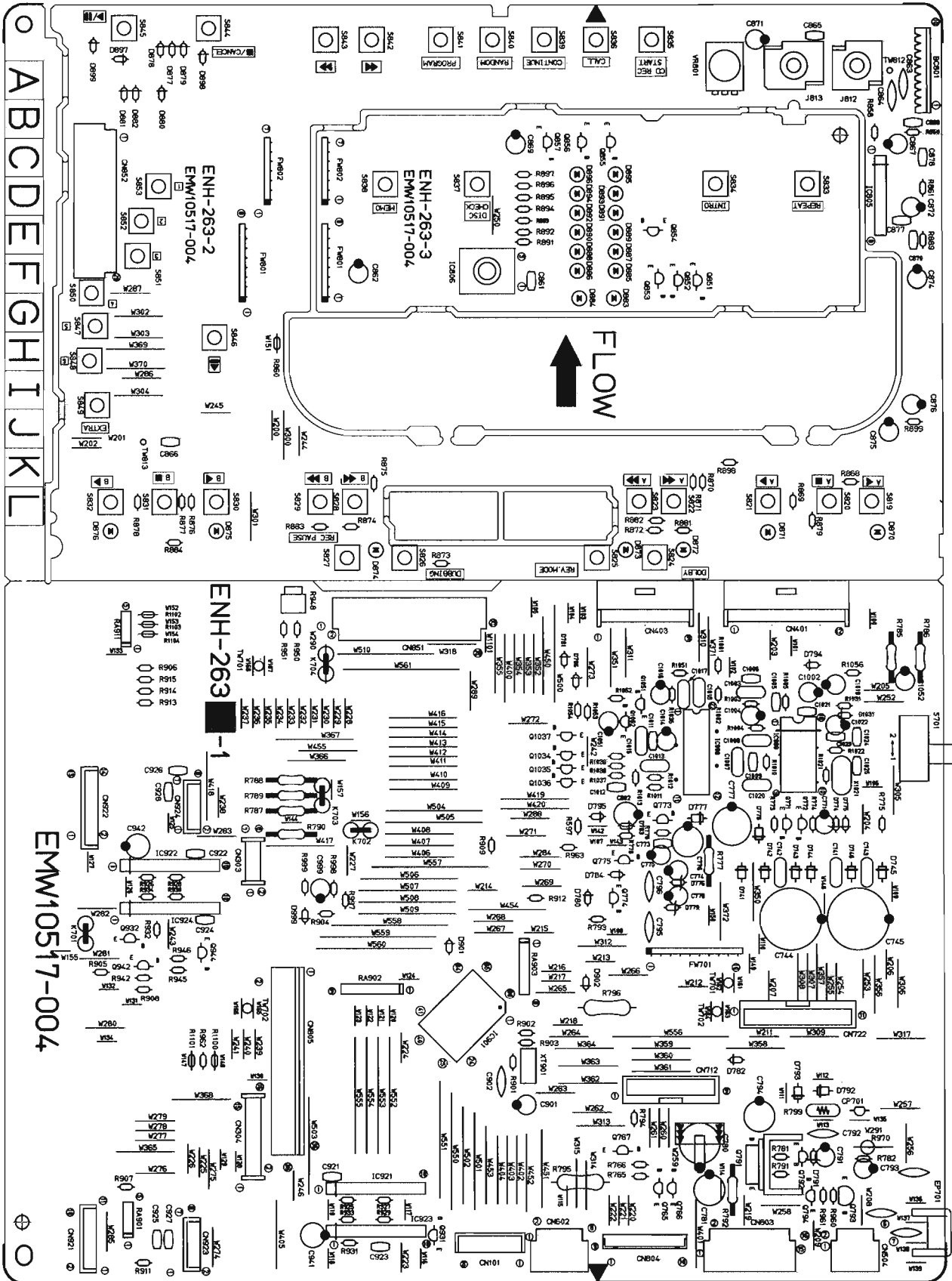

Note(3)

PC Board Ass'y	Designated Areas
ENH-263 A	U.S.A.
ENH-263 B	Canada
ENH-263 C	Singapore,Taiwan, Other Countries
ENH-263 D	the U.K.,Eastern Europe Scandinavia,Germany,Italy Continental Europe
ENH-263 E	Austraria

TRANSISTORS

ITEM	PART NUMBER	DESCRIPTION	AREA
Q765	2SD2144S(VW)	SI.TRANSIST ROHM	
Q766	2SD2144S(VW)	SI.TRANSIST ROHM	
Q767	DTA114YS	DIGITAL TRA ROHM	
Q771	DTC114YS	DIGITAL TRA ROHM	
Q772	DTC114YS	DIGITAL TRA ROHM	
Q773	2SA934(Q,R)	SI.TRANSIST ROHM	
Q774	DTC144ES	DIGITAL TRA ROHM	
Q775	DTC114YS	DIGITAL TRA ROHM	
Q791	2SB1187(F,G)	SI.TRANSIST ROHM	
Q792	2SC3311A(Q,R)	SI.TRANSIST MATSUSHITA	
Q793	2SA934(Q,R)	SI.TRANSIST ROHM	
Q794	DTC114YS	DIGITAL TRA ROHM	
Q851	DTC144ES	DIGITAL TRA ROHM	
Q852	DTC144ES	DIGITAL TRA ROHM	
Q853	DTC144ES	DIGITAL TRA ROHM	
Q854	DTC144ES	DIGITAL TRA ROHM	
Q855	DTC144ES	DIGITAL TRA ROHM	
Q856	DTC144ES	DIGITAL TRA ROHM	
Q857	DTC144ES	DIGITAL TRA ROHM	
Q931	DTC144ES	DIGITAL TRA ROHM	
Q932	DTC144ES	DIGITAL TRA ROHM	
Q942	2SC3311A(Q,R)	SI.TRANSIST MATSUSHITA	
Q944	2SA933S(RS)	SI.TRANSIST	
Q1034	DTC144ES	DIGITAL TRA ROHM	U
Q1034	DTC144ES	DIGITAL TRA ROHM	US
Q1034	DTC144ES	DIGITAL TRA ROHM	UT
Q1035	DTC144ES	DIGITAL TRA ROHM	U
Q1035	DTC144ES	DIGITAL TRA ROHM	US
Q1035	DTC144ES	DIGITAL TRA ROHM	UT
Q1036	DTC144ES	DIGITAL TRA ROHM	U
Q1036	DTC144ES	DIGITAL TRA ROHM	US
Q1036	DTC144ES	DIGITAL TRA ROHM	UT
Q1037	DTC144ES	DIGITAL TRA ROHM	U
Q1037	DTC144ES	DIGITAL TRA ROHM	US
Q1037	DTC144ES	DIGITAL TRA ROHM	UT
Q1051	2SC3311A(Q,R)	SI.TRANSIST MATSUSHITA	U
Q1051	2SC3311A(Q,R)	SI.TRANSIST MATSUSHITA	US
Q1051	2SC3311A(Q,R)	SI.TRANSIST MATSUSHITA	UT
Q1052	2SC3311A(Q,R)	SI.TRANSIST MATSUSHITA	U
Q1052	2SC3311A(Q,R)	SI.TRANSIST MATSUSHITA	US
Q1052	2SC3311A(Q,R)	SI.TRANSIST MATSUSHITA	UT

Δ : SAFETY PARTS

I.C.S

ITEM	PART NUMBER	DESCRIPTION	AREA
IC805	BA15218N	I.C(MONO-AN ROHM	U
IC805	BA15218N	I.C(MONO-AN ROHM	US
IC805	BA15218N	I.C(MONO-AN ROHM	UT
IC806	NJH32H380A	I.C(M) DAINICHI	
IC901	HD404719A62FS	I.C(MICRO-C HITACHI	
IC921	LB1641	I.C(DIGI-OT SANYO	
IC922	LB1641	I.C(DIGI-OT SANYO	
IC923	LB1641	I.C(DIGI-OT SANYO	
IC924	LB1641	I.C(DIGI-OT SANYO	
IC998	BA7725S	I.C(MONO-AN ROHM	U
IC998	BA7725S	I.C(MONO-AN ROHM	US
IC998	BA7725S	I.C(MONO-AN ROHM	UT
IC999	BU9251S	I.C(M) ROHM	U
IC999	BU9251S	I.C(M) ROHM	US
IC999	BU9251S	I.C(M) ROHM	UT

Δ : SAFETY PARTS

DIODES

ITEM	PART NUMBER	DESCRIPTION	AREA
Δ D741	1SR35-100	SI.DIODE ROHM	
Δ D742	1SR35-100	SI.DIODE ROHM	
Δ D743	1SR35-100	SI.DIODE ROHM	
Δ D744	1SR35-100	SI.DIODE ROHM	
Δ D745	1SR35-100	SI.DIODE ROHM	
Δ D746	1SR35-100	SI.DIODE ROHM	
D774	MT25.1JC	ZENER DIODE ROHM	
D775	1SS119	SI.DIODE	
D776	MT236JC	ZENER DIODE ROHM	
Δ D777	1SR35-100	SI.DIODE ROHM	
Δ D778	1SR35-100	SI.DIODE ROHM	
D779	MT26.2JC	ZENER DIODE ROHM	
D780	1SS119	SI.DIODE	
D781	1SS119	SI.DIODE	
D782	1SS119	SI.DIODE	
D783	1SS119	SI.DIODE	
D784	1SS119	SI.DIODE	
D791	MT26.8JB	ZENER DIODE ROHM	
D792	1SR35-100	SI.DIODE ROHM	
D793	1SR35-100	SI.DIODE ROHM	
D794	1SS119	SI.DIODE	
D795	R8721Q	SI.DIODE ROHM	
D796	1SS119	SI.DIODE	
D870	SLR-342MCA47	L.E.D. ROHM	
D871	SLR-342MCA47	L.E.D. ROHM	
D872	SLR-342VC3F	L.E.D. ROHM	
D873	SLR-342VC3F	L.E.D. ROHM	
D874	SLR-342VC3F	L.E.D. ROHM	
D875	SLR-342MCA47	L.E.D. ROHM	
D876	SLR-342MCA47	L.E.D. ROHM	
D877	1SS119	SI.DIODE	
D878	1SS119	SI.DIODE	
D879	1SS119	SI.DIODE	
D880	1SS119	SI.DIODE	
D881	1SS119	SI.DIODE	
D882	1SS119	SI.DIODE	
D883	SLR-320VCA49	L.E.D. ROHM	
D884	SLR-320VCA49	L.E.D. ROHM	
D885	SLR-320MCA49	L.E.D. ROHM	
D886	SLR-320MCA49	L.E.D. ROHM	
D887	SLR-320MCA49	L.E.D. ROHM	
D888	SLR-320MCA49	L.E.D. ROHM	
D889	SLR-320MCA49	L.E.D. ROHM	
D890	SLR-320MCA49	L.E.D. ROHM	
D891	SLR-320MCA49	L.E.D. ROHM	
D892	SLR-320MCA49	L.E.D. ROHM	
D893	SLR-320MCA49	L.E.D. ROHM	
D894	SLR-320MCA49	L.E.D. ROHM	
D895	SLR-320MCA49	L.E.D. ROHM	
D896	SLR-320MCA49	L.E.D. ROHM	
D897	1SS119	SI.DIODE	
D898	1SS119	SI.DIODE	
D899	1SS119	SI.DIODE	
D901	1SS119	SI.DIODE	
D902	1SS119	SI.DIODE	
D999	1SS119	SI.DIODE	
D1031	MT25.1JC	ZENER DIODE ROHM	U
D1031	MT25.1JC	ZENER DIODE ROHM	US
D1031	MT25.1JC	ZENER DIODE ROHM	UT
D1100	MT23.OJB	ZENER DIODE ROHM	

Δ : SAFETY PARTS

CAPACITORS

ITEM	PART NUMBER	DESCRIPTION	AREA
C741	QFN82AJ-103	0.01MF 100V MYLAR CAPA	J
C741	QFN82AJ-103	0.01MF 100V MYLAR CAPA	U
C741	QFN82AJ-103	0.01MF 100V MYLAR CAPA	US
C741	QFN82AJ-103	0.01MF 100V MYLAR CAPA	UT
C741	QFV82AJ-224	0.22MF 100V MYLAR CAPA	A
C741	QFV82AJ-224	0.22MF 100V MYLAR CAPA	BS
C741	QFV82AJ-224	0.22MF 100V MYLAR CAPA	C
C741	QFV82AJ-224	0.22MF 100V MYLAR CAPA	EF
C741	QFV82AJ-224	0.22MF 100V MYLAR CAPA	EN
C741	QFV82AJ-224	0.22MF 100V MYLAR CAPA	G
C741	QFV82AJ-224	0.22MF 100V MYLAR CAPA	GI
C741	QFV82AJ-224	0.22MF 100V MYLAR CAPA	VX
C742	QFN82AJ-103	0.01MF 100V MYLAR CAPA	J
C742	QFN82AJ-103	0.01MF 100V MYLAR CAPA	U
C742	QFN82AJ-103	0.01MF 100V MYLAR CAPA	US
C742	QFN82AJ-103	0.01MF 100V MYLAR CAPA	UT
C742	QFV82AJ-224	0.22MF 100V MYLAR CAPA	A
C742	QFV82AJ-224	0.22MF 100V MYLAR CAPA	BS
C742	QFV82AJ-224	0.22MF 100V MYLAR CAPA	C
C742	QFV82AJ-224	0.22MF 100V MYLAR CAPA	EF
C742	QFV82AJ-224	0.22MF 100V MYLAR CAPA	EN
C742	QFV82AJ-224	0.22MF 100V MYLAR CAPA	G
C742	QFV82AJ-224	0.22MF 100V MYLAR CAPA	GI
C742	QFV82AJ-224	0.22MF 100V MYLAR CAPA	VX
C743	QFN82AJ-103	0.01MF 100V MYLAR CAPA	J

Δ : SAFETY PARTS

CAPACITORS

Δ	ITEM	PART NUMBER	DESCRIPTION			AREA
	C743	QFN82AJ-103	0.01MF	100V	MYLAR CAPA	U
	C743	QFN82AJ-103	0.01MF	100V	MYLAR CAPA	US
	C743	QFN82AJ-103	0.01MF	100V	MYLAR CAPA	UT
	C743	QFV82AJ-224	0.22MF	100V	MYLAR CAPA	A
	C743	QFV82AJ-224	0.22MF	100V	MYLAR CAPA	BS
	C743	QFV82AJ-224	0.22MF	100V	MYLAR CAPA	C
	C743	QFV82AJ-224	0.22MF	100V	MYLAR CAPA	EF
	C743	QFV82AJ-224	0.22MF	100V	MYLAR CAPA	EN
	C743	QFV82AJ-224	0.22MF	100V	MYLAR CAPA	G
	C743	QFV82AJ-224	0.22MF	100V	MYLAR CAPA	GI
	C743	QFV82AJ-224	0.22MF	100V	MYLAR CAPA	VX
	C744	QETM1VM-228J7	2200MF	35V	E.CAPACITO	
	C745	QETM1VM-228J7	2200MF	35V	E.CAPACITO	
	C771	QETB1HM-225	2.2MF	50V	AL E.CAPAC	
	C773	QCVB1CM-103Y	0.01MF	16V	CER.CAPACI	
	C774	QETB1HM-226E	22MF	50V	E.CAPACITO	
	C775	QETB1HM-226E	22MF	50V	E.CAPACITO	
	C776	QETB1JM-476	47MF	63V	AL E.CAPAC	
	C777	QETB1JM-107	100MF	63V	AL E.CAPAC	
	C778	QETB1HM-475E	4.7MF	50V	E.CAPACITO	
	C780	QEZ0171-10AM			AL E.CAPAC	
	C781	QETB1CM-227	220MF	16V	AL E.CAPAC	
	C791	QETB1CM-476	47MF	16V	AL E.CAPAC	
	C792	QCF21HP-223A	0.022MF	50V	CER.CAPACI	
	C793	QETB1AM-107	100MF	10V	AL E.CAPAC	
	C794	QETB1AM-107	100MF	10V	AL E.CAPAC	
	C795	QCF21HP-103A	0.01MF	50V	CER.CAPACI	
	C796	QCF21HP-103A	0.01MF	50V	CER.CAPACI	
	C799	QCF21HP-223A	0.022MF	50V	CER.CAPACI	
	C799	QCF21HP-223A	0.022MF	50V	CER.CAPACI	A
	C799	QCF21HP-223A	0.022MF	50V	CER.CAPACI	C
	C799	QCF21HP-223A	0.022MF	50V	CER.CAPACI	J
	C799	QCF21HP-223A	0.022MF	50V	CER.CAPACI	U
	C799	QCF21HP-223A	0.022MF	50V	CER.CAPACI	US
	C799	QCF21HP-223A	0.022MF	50V	CER.CAPACI	UT
	C802	QETB1HM-105	1MF	50V	AL E.CAPAC	
	C861	QCHB1EZ-223	0.022MF	25V	CER.CAPACI	
	C862	QER50JM-107	100MF	6.3V	AL E.CAPAC	
	C863	QCS31HJ-471Z	470PF	50V	CER.CAPACI	BS
	C863	QCS31HJ-471Z	470PF	50V	CER.CAPACI	EF
	C863	QCS31HJ-471Z	470PF	50V	CER.CAPACI	EN
	C863	QCS31HJ-471Z	470PF	50V	CER.CAPACI	GI
	C863	QCS31HJ-471Z	470PF	50V	CER.CAPACI	G
	C863	QCS31HJ-471Z	470PF	50V	CER.CAPACI	VX
	C864	QCS31HJ-471Z	470PF	50V	CER.CAPACI	BS
	C864	QCS31HJ-471Z	470PF	50V	CER.CAPACI	EF
	C864	QCS31HJ-471Z	470PF	50V	CER.CAPACI	EN
	C864	QCS31HJ-471Z	470PF	50V	CER.CAPACI	G
	C864	QCS31HJ-471Z	470PF	50V	CER.CAPACI	GI
	C864	QCS31HJ-471Z	470PF	50V	CER.CAPACI	VX
	C865	QCVB1CM-103Y	0.01MF	16V	CER.CAPACI	
	C865	QCVB1CM-103Y	0.01MF	16V	CER.CAPACI	U
	C865	QCVB1CM-103Y	0.01MF	16V	CER.CAPACI	US
	C865	QCVB1CM-103Y	0.01MF	16V	CER.CAPACI	UT
	C866	QCHB1EZ-223	0.022MF	25V	CER.CAPACI	BS
	C866	QCHB1EZ-223	0.022MF	25V	CER.CAPACI	EF
	C866	QCHB1EZ-223	0.022MF	25V	CER.CAPACI	EN
	C866	QCHB1EZ-223	0.022MF	25V	CER.CAPACI	G
	C866	QCHB1EZ-223	0.022MF	25V	CER.CAPACI	GI
	C866	QCHB1EZ-223	0.022MF	25V	CER.CAPACI	VX
	C867	QEK51HM-105G	1MF	50V	AL E.CAPAC	
	C867	QEK51HM-105G	1MF	50V	AL E.CAPAC	U
	C867	QEK51HM-105G	1MF	50V	AL E.CAPAC	US
	C868	QCVB1CM-103Y	0.01MF	16V	CER.CAPACI	UT
	C868	QCVB1CM-103Y	0.01MF	16V	CER.CAPACI	U
	C868	QCVB1CM-103Y	0.01MF	16V	CER.CAPACI	US
	C869	QEK51CM-107	100MF	16V	E.CAPACITO	
	C870	QCVB1CM-103Y	0.01MF	16V	CER.CAPACI	U
	C870	QCVB1CM-103Y	0.01MF	16V	CER.CAPACI	US
	C871	QEK51HM-105	1MF	50V	AL E.CAPAC	U
	C871	QEK51HM-105	1MF	50V	AL E.CAPAC	US
	C871	QEK51HM-105	1MF	50V	AL E.CAPAC	UT
	C872	QETB1HM-105	1MF	50V	AL E.CAPAC	U
	C872	QETB1HM-105	1MF	50V	AL E.CAPAC	US
	C872	QETB1HM-105	1MF	50V	AL E.CAPAC	UT
	C872	QETB1HM-105	1MF	50V	AL E.CAPAC	U
	C874	QETB1HM-105	1MF	50V	AL E.CAPAC	U
	C874	QETB1HM-105	1MF	50V	AL E.CAPAC	US
	C874	QETB1HM-105	1MF	50V	AL E.CAPAC	UT
	C875	QEK51EM-106	10MF	25V	AL E.CAPAC	U
	C875	QEK51EM-106	10MF	25V	AL E.CAPAC	US
	C875	QEK51EM-106	10MF	25V	AL E.CAPAC	UT
	C876	QETB1EM-106	10MF	25V	AL E.CAPAC	U
	C876	QETB1EM-106	10MF	25V	AL E.CAPAC	US
	C876	QETB1EM-106	10MF	25V	AL E.CAPAC	UT
	C877	QCB1HK-101Y	100PF	50V	CER.CAPACI	U
	C877	QCB1HK-101Y	100PF	50V	CER.CAPACI	US
	C877	QCB1HK-101Y	100PF	50V	CER.CAPACI	UT
	C878	QCB1HK-101Y	100PF	50V	CER.CAPACI	U
	C878	QCB1HK-101Y	100PF	50V	CER.CAPACI	US
	C878	QCB1HK-101Y	100PF	50V	CER.CAPACI	UT

Δ IS SAFETY PARTS

CAPASITORS

Δ	ITEM	PART NUMBER	DESCRIPTION			AREA
	C878	QCB1HK-101Y	100PF	50V	CER.CAPACI	UT
	C901	QETB1AM-107	100MF	10V	AL E.CAPAC	
	C902	QCF21HP-103A	0.01MF	50V	CER.CAPACI	
	C921	QCVB1CM-103Y	0.01MF	16V	CER.CAPACI	
	C922	QCVB1CM-103Y	0.01MF	16V	CER.CAPACI	
	C923	QCVB1CM-103Y	0.01MF	16V	CER.CAPACI	
	C924	QCVB1CM-103Y	0.01MF	16V	CER.CAPACI	
	C925	QCHB1EZ-223	0.022MF	25V	CER.CAPACI	
	C926	QCHB1EZ-223	0.022MF	25V	CER.CAPACI	
	C927	QCHB1EZ-223	0.022MF	25V	CER.CAPACI	
	C928	QCHB1EZ-223	0.022MF	25V	CER.CAPACI	
	C941	QETB1CM-107	100MF	16V	AL E.CAPAC	
	C942	QETB1CM-107	100MF	16V	AL E.CAPAC	
	C999	QETB1CM-476	47MF	16V	AL E.CAPAC	
	C1002	QETB1CM-226	22MF	16V	E.CAPACITO	U
	C1002	QETB1CM-226	22MF	16V	E.CAPACITO	US
	C1002	QETB1CM-226	22MF	16V	E.CAPACITO	UT
	C1003	QFN81HJ-104	0.1MF	50V	METAL.MYLA	U
	C1003	QFN81HJ-104	0.1MF	50V	METAL.MYLA	US
	C1003	QFN81HJ-104	0.1MF	50V	METAL.MYLA	UT
	C1004	QETB1HM-474	0.47MF	50V	ELECTRO	U
	C1004	QETB1HM-474	0.47MF	50V	ELECTRO	US
	C1004	QETB1HM-474	0.47MF	50V	ELECTRO	UT
	C1005	QCVB1CM-562Y	5600PF	16V	CER.CAPACI	U
	C1005	QCVB1CM-562Y	5600PF	16V	CER.CAPACI	US
	C1005	QCVB1CM-562Y	5600PF	16V	CER.CAPACI	UT
	C1006	QCVB1CM-562Y	5600PF	16V	CER.CAPACI	U
	C1006	QCVB1CM-562Y	5600PF	16V	CER.CAPACI	US
	C1006	QCVB1CM-562Y	5600PF	16V	CER.CAPACI	UT
	C1007	QFN81HJ-183	0.018MF	50V	METAL.MYLA	U
	C1007	QFN81HJ-183	0.018MF	50V	METAL.MYLA	US
	C1007	QFN81HJ-183	0.018MF	50V	METAL.MYLA	UT
	C1008	QFN81HJ-104	0.1MF	50V	METAL.MYLA	U
	C1008	QFN81HJ-104	0.1MF	50V	METAL.MYLA	US
	C1008	QFN81HJ-104	0.1MF	50V	METAL.MYLA	UT
	C1008	QFN81HJ-104	0.1MF	50V	METAL.MYLA	U
	C1009	QCVB1CM-103Y	0.01MF	16V	CER.CAPACI	U
	C1009	QCVB1CM-103Y	0.01MF	16V	CER.CAPACI	US
	C1009	QCVB1CM-103Y	0.01MF	16V	CER.CAPACI	UT
	C1011	QCVB1CM-103Y	0.01MF	16V	CER.CAPACI	U
	C1011	QCVB1CM-103Y	0.01MF	16V	CER.CAPACI	US
	C1011	QCVB1CM-103Y	0.01MF	16V	CER.CAPACI	UT
	C1011	QCVB1CM-103Y	0.01MF	16V	CER.CAPACI	U
	C1012	QCVB1CM-562Y	5600PF	16V	CER.CAPACI	U
	C1012	QCVB1CM-562Y	5600PF	16V	CER.CAPACI	US
	C1012	QCVB1CM-562Y	5600PF	16V	CER.CAPACI	UT
	C1012	QCVB1CM-562Y	5600PF	16V	CER.CAPACI	U
	C1013	QFN81HJ-183	0.018MF	50V	METAL.MYLA	U
	C1013	QFN81HJ-183	0.018MF	50V	METAL.MYLA	US
	C1013	QFN81HJ-183	0.018MF	50V	METAL.MYLA	UT
	C1014	QETB1HM-474	0.47MF	50V	ELECTRO	US
	C1014	QETB1HM-474	0.47MF	50V	ELECTRO	UT
	C1015	QFN81HJ-104	0.1MF	50V	METAL.MYLA	U
	C1015	QFN81HJ-104	0.1MF	50V	METAL.MYLA	US
	C1015	QFN81HJ-104	0.1MF	50V	METAL.MYLA	UT
	C1016	QETB1HM-105	1MF	50V	AL E.CAPAC	U
	C1016	QETB1HM-105	1MF	50V	AL E.CAPAC	US
	C1016	QETB1HM-105	1MF	50V	AL E.CAPAC	UT
	C1016	QETB1HM-105	1MF	50V	AL E.CAPAC	U
	C1017	QFV81HJ-104	0.1MF	50V	THIN FILM	U
	C1017	QFV81HJ-104	0.1MF	50V	THIN FILM	US
	C1017	QFV81HJ-104	0.1MF	50V	THIN FILM	UT
	C1017	QFV81HJ-104	0.1MF	50V	THIN FILM	U
	C1018	QFV81HJ-104	0.1MF	50V	THIN FILM	U
	C1018	QFV81HJ-104	0.1MF	50V	THIN FILM	US
	C1018	QFV81HJ-104	0.1MF	50V	THIN FILM	UT
	C1018	QFV81HJ-104	0.1MF	50V	THIN FILM	U
	C1019	QETB1CM-107	100MF	16V	AL E.CAPAC	J
	C1019	QETB1CM-107	100MF	16V	AL E.CAPAC	US
	C1019	QETB1CM-107	100MF	16V	AL E.CAPAC	UT
	C1019	QETB1CM-107	100MF	16V	AL E.CAPAC	U
	C1020	QFN81HJ-104	0.1MF	50V	METAL.MYLA	U
	C1020	QFN81HJ-104	0.1MF	50V	METAL.MYLA	US
	C1020	QFN81HJ-104	0.1MF	50V	METAL.MYLA	UT
	C1020	QFN81HJ-104	0.1MF	50V	METAL.MYLA	U
	C1021	QCB1HK-221Y	220PF	50V	CER.CAPACI	U
	C1021	QCB1HK-221Y	220PF	50V	CER.CAPACI	US
	C1021	QCB1HK-221Y	220PF	50V	CER.CAPACI	UT
	C1021	QCB1HK-221Y	220PF	50V	CER.CAPACI	U
	C1022	QETB1AM-107	100MF	10V	AL E.CAPAC	U
	C1022	QETB1AM-107	100MF	10V	AL E.CAPAC	US
	C1022	QETB1AM-107	100MF	10V	AL E.CAPAC	UT
	C1022	QETB1AM-107	100MF	10V	AL E.CAPAC	U
	C1023	QCVB1CM-103Y	0.01MF	16V	CER.CAPACI	U
	C1023	QCVB1CM-103Y	0.01MF	16V	CER.CAPACI	US
	C1023	QCVB1CM-103Y	0.01MF	16V	CER.CAPACI	UT
	C1023	QCVB1CM-103Y	0.01MF	16V	CER.CAPACI	U
	C1024	QCB1HK-221Y	220PF	50V	CER.CAPACI	U
	C1024	QCB1HK-221Y	220PF	50V	CER.CAPACI	US
	C1024	QCB1HK-221Y	220PF	50V	CER.CAPACI	UT
	C1024	QCB1HK-221Y	220PF	50V	CER.CAPACI	U
	C1025	QCB1HK-221Y	220PF	50V	CER.CAPACI	U
	C1025	QCB1HK-221Y	220PF	50V	CER.CAPACI	US
	C1025	QCB1HK-221Y	220PF	50V	CER.CAPACI	UT
	C1025	QCB1HK-221Y	220PF	50V		

RESISTORS

Δ	ITEM	PART NUMBER	DESCRIPTION			AREA
	R597	QRD161J-102	1K	1/6W	CARBON RES	
	R765	QRD161J-473	47K	1/6W	CARBON RES	
	R766	QRD161J-473	47K	1/6W	CARBON RES	
	R773	QRD161J-102	1K	1/6W	CARBON RES	
	R774	QRD161J-472	4.7K	1/6W	CARBON RES	
	R775	QRD161J-103	10K	1/6W	CARBON RES	
	R776	QRD161J-102	1K	1/6W	CARBON RES	
Δ	R777	PTH61G25AR4R7M			POSITIVE T	A
Δ	R777	PTH61G25AR4R7M			POSITIVE T	BS
Δ	R777	PTH61G25AR4R7M			POSITIVE T	C
Δ	R777	PTH61G25AR4R7M			POSITIVE T	EF
Δ	R777	PTH61G25AR4R7M			POSITIVE T	EN
Δ	R777	PTH61G25AR4R7M			POSITIVE T	G
Δ	R777	PTH61G25AR4R7M			POSITIVE T	GI
Δ	R777	PTH61G25AR4R7M			POSITIVE T	U
Δ	R777	PTH61G25AR4R7M			POSITIVE T	US
Δ	R777	PTH61G25AR4R7M			POSITIVE T	UT
Δ	R777	PTH61G25AR4R7M			POSITIVE T	VX
Δ	R777	QRD14CJ-4R7S	4.7	1/4W	UNF. CARBON	J
	R778	QRD161J-104	100K	1/6W	CARBON RES	
	R781	QRD167J-121	120	1/6W	CARBON RES	
	R782	QRD161J-222	2.2K	1/6W	CARBON RES	
Δ	R785	QRD14CJ-100SX	10	1/4W	UNF. CARBON	
Δ	R786	QRD14CJ-100SX	10	1/4W	UNF. CARBON	
Δ	R787	QRD14CJ-4R7S	4.7	1/4W	UNF. CARBON	
Δ	R788	QRD14CJ-4R7S	4.7	1/4W	UNF. CARBON	
Δ	R789	QRD14CJ-4R7S	4.7	1/4W	UNF. CARBON	
Δ	R790	QRD14CJ-4R7S	4.7	1/4W	UNF. CARBON	
	R791	QRD161J-122	1.2K	1/6W	CARBON RES	
	R793	QRD161J-103	10K	1/6W	CARBON RES	
	R794	QRD161J-103	10K	1/6W	CARBON RES	
Δ	R795	QRX022J-2R7AM	2.7	2W	METAL FILM	
Δ	R796	QRX022J-2R2AM	2.2	2W	METAL FILM	
	R858	QRD161J-122	1.2K	1/6W	CARBON RES	U
	R858	QRD161J-122	1.2K	1/6W	CARBON RES	US
	R858	QRD161J-122	1.2K	1/6W	CARBON RES	UT
	R859	QRD161J-103	10K	1/6W	CARBON RES	U
	R859	QRD161J-103	10K	1/6W	CARBON RES	US
	R859	QRD161J-103	10K	1/6W	CARBON RES	UT
	R861	QRD161J-122	1.2K	1/6W	CARBON RES	U
	R861	QRD161J-122	1.2K	1/6W	CARBON RES	US
	R861	QRD161J-122	1.2K	1/6W	CARBON RES	UT
	R868	QRD161J-222	2.2K	1/6W	CARBON RES	
	R869	QRD161J-112	1.1K	1/6W	CARBON RES	
	R870	QRD161J-681	680	1/6W	CARBON RES	
	R871	QRD167J-431	430	1/6W	CARBON RES	
	R872	QRD161J-112	1.1K	1/6W	CARBON RES	
	R873	QRD161J-681	680	1/6W	CARBON RES	
	R874	QRD167J-431	430	1/6W	CARBON RES	
	R875	QRD161J-222	2.2K	1/6W	CARBON RES	
	R876	QRD161J-112	1.1K	1/6W	CARBON RES	
	R877	QRD161J-681	680	1/6W	CARBON RES	
	R878	QRD167J-431	430	1/6W	CARBON RES	
	R879	QRD167J-161	160	1/6W	CARBON RES	
	R881	QRD161J-271	270	1/6W	CARBON RES	
	R882	QRD161J-271	270	1/6W	CARBON RES	
	R883	QRD161J-391	390	1/6W	CARBON RES	
	R884	QRD167J-161	160	1/6W	CARBON RES	
	R889	QRD161J-103	10K	1/6W	CARBON RES	U
	R889	QRD161J-103	10K	1/6W	CARBON RES	US
	R889	QRD161J-103	10K	1/6W	CARBON RES	UT
	R891	QRD167J-121	120	1/6W	CARBON RES	
	R892	QRD161J-101	100	1/6W	CARBON RES	
	R893	QRD161J-101	100	1/6W	CARBON RES	
	R894	QRD161J-101	100	1/6W	CARBON RES	
	R895	QRD161J-101	100	1/6W	CARBON RES	
	R896	QRD161J-101	100	1/6W	CARBON RES	
	R897	QRD161J-101	100	1/6W	CARBON RES	
	R898	QRD161J-221	220	1/6W	CARBON RES	U
	R898	QRD161J-221	220	1/6W	CARBON RES	US
	R898	QRD161J-221	220	1/6W	CARBON RES	UT
	R899	QRD161J-221	220	1/6W	CARBON RES	U
	R899	QRD161J-221	220	1/6W	CARBON RES	US
	R899	QRD161J-221	220	1/6W	CARBON RES	UT
	R901	QRD161J-105	1M	1/6W	CARBON RES	U
	R902	QRD161J-103	10K	1/6W	CARBON RES	
	R903	QRD167J-223	22K	1/6W	CARBON RES	
	R904	QRD161J-103	10K	1/6W	CARBON RES	
	R905	QRD161J-102	1K	1/6W	CARBON RES	
	R906	QRD161J-102	1K	1/6W	CARBON RES	
	R907	QRD161J-102	1K	1/6W	CARBON RES	
	R908	QRD161J-473	47K	1/6W	CARBON RES	
	R909	QRD167J-223	22K	1/6W	CARBON RES	
	R911	QRD161J-103	10K	1/6W	CARBON RES	
	R912	QRD161J-103	10K	1/6W	CARBON RES	
	R913	QRD161J-392	3.9K	1/6W	CARBON RES	
	R914	QRD161J-242	2.4K	1/6W	CARBON RES	
	R915	QRD167J-153	15K	1/6W	CARBON RES	
	R925	QRD161J-432	4.3K	1/6W	CARBON RES	
	R926	QRD161J-432	4.3K	1/6W	CARBON RES	

Δ : SAFETY PARTS

RESISTORS

Δ	ITEM	PART NUMBER	DESCRIPTION			AREA
	R927	QRD161J-103	10K	1/6W	CARBON RES	
	R928	QRD161J-103	10K	1/6W	CARBON RES	
	R929	QRD161J-913	91K	1/6W	CARBON RES	
	R930	QRD161J-913	91K	1/6W	CARBON RES	
	R931	QRD167J-822	8.2K	1/6W	CARBON RES	
	R932	QRD167J-822	8.2K	1/6W	CARBON RES	
	R933	QRD161J-163	16K	1/6W	CARBON RES	
	R934	QRD161J-163	16K	1/6W	CARBON RES	
	R942	QRD161J-103	10K	1/6W	CARBON RES	
	R945	QRD161J-224	220K	1/6W	CARBON RES	
	R946	QRD161J-224	220K	1/6W	CARBON RES	
	R948	QVPA603-103A	10K		TRIMMER RE	
	R950	QRD161J-133Y	13K	1/6W	CARBON RES	
	R951	QRD161J-683	68K	1/6W	CARBON RES	
	R960	QRD161J-472	4.7K	1/6W	CARBON RES	
	R961	QRD161J-331	330	1/6W	CARBON RES	
	R962	QRD161J-222	2.2K	1/6W	CARBON RES	
	R963	QRD161J-103	10K	1/6W	CARBON RES	
Δ	R970	QRX014J-R47X	0.47	1W	M. FILM	J
	R997	QRD167J-562	5.6K	1/6W	CARBON RES	
	R998	QRD161J-104	100K	1/6W	CARBON RES	
	R999	QRD161J-274	270K	1/6W	CARBON RES	
	RA901	QRB049J-103	10K	1/10W	RESISTOR	
	RA903	QRB079J-222	2.2K	1/10W	NETWORK RE	
	RA911	QRB049J-103	10K	1/10W	RESISTOR	
	R1001	QRD167J-152	1.5K	1/6W	CARBON RES	U
	R1001	QRD167J-152	1.5K	1/6W	CARBON RES	US
	R1001	QRD167J-152	1.5K	1/6W	CARBON RES	UT
	R1002	QRD161J-123	12K	1/6W	CARBON RES	U
	R1002	QRD161J-123	12K	1/6W	CARBON RES	US
	R1002	QRD161J-123	12K	1/6W	CARBON RES	UT
	R1003	QRD161J-103	10K	1/6W	CARBON RES	U
	R1003	QRD161J-103	10K	1/6W	CARBON RES	US
	R1003	QRD161J-103	10K	1/6W	CARBON RES	UT
	R1004	QRD161J-103	10K	1/6W	CARBON RES	U
	R1004	QRD161J-103	10K	1/6W	CARBON RES	US
	R1004	QRD161J-103	10K	1/6W	CARBON RES	UT
	R1005	QRD161J-103	10K	1/6W	CARBON RES	U
	R1005	QRD161J-103	10K	1/6W	CARBON RES	US
	R1005	QRD161J-103	10K	1/6W	CARBON RES	UT
	R1010	QRD161J-472	4.7K	1/6W	CARBON RES	U
	R1010	QRD161J-472	4.7K	1/6W	CARBON RES	US
	R1010	QRD161J-472	4.7K	1/6W	CARBON RES	UT
	R1011	QRD161J-103	10K	1/6W	CARBON RES	U
	R1011	QRD161J-103	10K	1/6W	CARBON RES	US
	R1011	QRD161J-103	10K	1/6W	CARBON RES	UT
	R1012	QRD161J-103	10K	1/6W	CARBON RES	U
	R1012	QRD161J-103	10K	1/6W	CARBON RES	US
	R1012	QRD161J-103	10K	1/6W	CARBON RES	UT
	R1013	QRD161J-103	10K	1/6W	CARBON RES	U
	R1013	QRD161J-103	10K	1/6W	CARBON RES	US
	R1013	QRD161J-103	10K	1/6W	CARBON RES	UT
	R1021	QRD161J-105	1M	1/6W	CARBON RES	U
	R1021	QRD161J-105	1M	1/6W	CARBON RES	US
	R1021	QRD161J-105	1M	1/6W	CARBON RES	UT
	R1022	QRD167J-682	6.8K	1/6W	CARBON RES	U
	R1022	QRD167J-682	6.8K	1/6W	CARBON RES	US
	R1022	QRD167J-682	6.8K	1/6W	CARBON RES	UT
	R1031	QRD161J-331	330	1/6W	CARBON RES	U
	R1031	QRD161J-331	330	1/6W	CARBON RES	US
	R1031	QRD161J-331	330	1/6W	CARBON RES	UT
	R1035	QRD161J-303Y	30K	1/6W	CARBON RES	U
	R1035	QRD161J-303Y	30K	1/6W	CARBON RES	US
	R1035	QRD161J-303Y	30K	1/6W	CARBON RES	UT
	R1036	QRD161J-563	56K	1/6W	CARBON RES	U
	R1036	QRD161J-563	56K	1/6W	CARBON RES	US
	R1036	QRD161J-563	56K	1/6W	CARBON RES	UT
	R1037	QRD161J-243	24K	1/6W	CARBON RES	U
	R1037	QRD161J-243	24K	1/6W	CARBON RES	US
	R1037	QRD161J-243	24K	1/6W	CARBON RES	UT
	R1038	QRD161J-123	12K	1/6W	CARBON RES	U
	R1038	QRD161J-123	12K	1/6W	CARBON RES	US
	R1038	QRD161J-123	12K	1/6W	CARBON RES	UT
	R1051	QRD161J-105	1M	1/6W	CARBON RES	U
	R1051	QRD161J-105	1M	1/6W	CARBON RES	US
	R1051	QRD161J-105	1M	1/6W	CARBON RES	UT
	R1052	QRD161J-243	24K	1/6W	CARBON RES	U
	R1052	QRD161J-243	24K	1/6W	CARBON RES	US
	R1052	QRD161J-243	24K	1/6W	CARBON RES	UT
	R1053	QRD161J-103	10K	1/6W	CARBON RES	U
	R1053	QRD161J-103	10K	1/6W	CARBON RES	US
	R1053	QRD161J-103	10K	1/6W	CARBON RES	UT
	R1054	QRD161J-472	4.7K	1/6W	CARBON RES	U
	R1054	QRD161J-472	4.7K	1/6W	CARBON RES	US
	R1054	QRD161J-472	4.7K	1/6W	CARBON RES	UT
	R1056	QRD161J-221	220	1/6W	CARBON RES	U
	R1056	QRD161J-221	220	1/6W	CARBON RES	US
	R1056	QRD161J-221	220	1/6W	CARBON RES	UT
	R1103	QRD161J-222	2.2K	1/6W	CARBON RES	U
	VR801	QVAA72B-E54B	50K		VARIABLE R	U
	VR801	QVAA72B-E54B	50K		VARIABLE R	US
	VR801	QVAA72B-E54B	50K		VARIABLE R	UT

Δ : SAFETY PARTS

OTHERS

Δ	ITEM	PART NUMBER	DESCRIPTION	AREA
	J812	EMW10517-004	CIR BOARD	
	J813	QMS3R10-E40S	MICROPHONE	
	J813	QMS3R80-EE0S	HEADPHONE J	U
	J813	QMS3R80-EE0S	HEADPHONE J	US
	J813	QMS3R80-EE0S	HEADPHONE J	UT
	K701	ENZ8101-007	INDUCTOR	BS
	K701	ENZ8101-007	INDUCTOR	EF
	K701	ENZ8101-007	INDUCTOR	EN
	K701	ENZ8101-007	INDUCTOR	G
	K701	ENZ8101-007	INDUCTOR	GI
	K701	ENZ8101-007	INDUCTOR	VX
	K702	ENZ8101-007	INDUCTOR	BS
	K702	ENZ8101-007	INDUCTOR	EF
	K702	ENZ8101-007	INDUCTOR	EN
	K702	ENZ8101-007	INDUCTOR	G
	K702	ENZ8101-007	INDUCTOR	GI
	K702	ENZ8101-007	INDUCTOR	VX
	K703	ENZ8101-007	INDUCTOR	BS
	K703	ENZ8101-007	INDUCTOR	EF
	K703	ENZ8101-007	INDUCTOR	EN
	K703	ENZ8101-007	INDUCTOR	G
	K703	ENZ8101-007	INDUCTOR	GI
	K703	ENZ8101-007	INDUCTOR	VX
	K704	ENZ8101-007	INDUCTOR	BS
	K704	ENZ8101-007	INDUCTOR	EF
	K704	ENZ8101-007	INDUCTOR	EN
	K704	ENZ8101-007	INDUCTOR	G
	K704	ENZ8101-007	INDUCTOR	GI
	K704	ENZ8101-007	INDUCTOR	VX
	S701	QSS7A12-E01	SLIDE SWITC	BS
	S701	QSS7A12-E01	SLIDE SWITC	EF
	S701	QSS7A12-E01	SLIDE SWITC	EN
	S701	QSS7A12-E01	SLIDE SWITC	G
	S701	QSS7A12-E01	SLIDE SWITC	GI
	S701	QSS7A12-E01	SLIDE SWITC	VX
	S819	ESP0001-023M	TACT SWITCH	
	S820	ESP0001-023M	TACT SWITCH	
	S821	ESP0001-023M	TACT SWITCH	
	S822	ESP0001-023M	TACT SWITCH	
	S823	ESP0001-023M	TACT SWITCH	
	S824	ESP0001-023M	TACT SWITCH	
	S825	ESP0001-023M	TACT SWITCH	
	S826	ESP0001-023M	TACT SWITCH	
	S827	ESP0001-023M	TACT SWITCH	
	S828	ESP0001-023M	TACT SWITCH	
	S829	ESP0001-023M	TACT SWITCH	
	S830	ESP0001-023M	TACT SWITCH	
	S831	ESP0001-023M	TACT SWITCH	
	S832	ESP0001-023M	TACT SWITCH	
	S833	ESP0001-023M	TACT SWITCH	
	S834	ESP0001-023M	TACT SWITCH	
	S835	ESP0001-023M	TACT SWITCH	
	S836	ESP0001-023M	TACT SWITCH	
	S837	ESP0001-023M	TACT SWITCH	
	S838	ESP0001-023M	TACT SWITCH	
	S839	ESP0001-023M	TACT SWITCH	
	S840	ESP0001-023M	TACT SWITCH	
	S841	ESP0001-023M	TACT SWITCH	
	S842	ESP0001-023M	TACT SWITCH	
	S843	ESP0001-023M	TACT SWITCH	
	S844	ESP0001-023M	TACT SWITCH	
	S845	ESP0001-023M	TACT SWITCH	
	S846	ESP0001-023M	TACT SWITCH	
	S847	ESP0001-023M	TACT SWITCH	
	S848	ESP0001-023M	TACT SWITCH	

Δ SAFETY PARTS

OTHERS

Δ	ITEM	PART NUMBER	DESCRIPTION	AREA
	S849	ESP0001-023M	TACT SWITCH	
	S850	ESP0001-023M	TACT SWITCH	
	S851	ESP0001-023M	TACT SWITCH	
	S852	ESP0001-023M	TACT SWITCH	
	S853	ESP0001-023M	TACT SWITCH	
	BC801	ESV32A-A942J	SOCKET WIRE	
	CN101	VMC0075-008N	CONNECT TER	
	CN303	VMC0314-S08	CONNECT TER	
	CN304	VMC0314-S16	CONNECT TER	
	CN401	EMV5163-012R	CONNECT TER	
	CN403	EMV5163-009R	CONNECT TER	
	CN504	VMC0161-R07	CONNECT TER	
	CN602	VMC0161-R09	CONNECT TER	
	CN712	EMV7163-009	CONNECT TER	
	CN722	EMV7163-011	CONNECT TER	
	CN803	VMC0161-R16	CONNECT TER	
	CN804	EMV5142-910	CONNECT TER	
	CN805	EMV7160-036	CONNECT TER	
	CN851	VMC0161-R29	CONNECT TER	
	CN852	VMC0161-R29	CONNECT TER	
	CN921	VMC0234-P11	CONNECT TER	
	CN922	VMC0234-P14	CONNECT TER	
	CN923	VMC0234-P08	CONNECT TER	
	CN924	VMC0234-P08	CONNECT TER	
	Δ CP701	ICP-N15	I.C.PROTECT	A
	Δ CP701	ICP-N15	I.C.PROTECT	BS
	Δ CP701	ICP-N15	I.C.PROTECT	C
	Δ CP701	ICP-N15	I.C.PROTECT	EF
	Δ CP701	ICP-N15	I.C.PROTECT	EN
	Δ CP701	ICP-N15	I.C.PROTECT	G
	Δ CP701	ICP-N15	I.C.PROTECT	GI
	Δ CP701	ICP-N15	I.C.PROTECT	U
	Δ CP701	ICP-N15	I.C.PROTECT	US
	Δ CP701	ICP-N15	I.C.PROTECT	UT
	Δ CP701	ICP-N15	I.C.PROTECT	VX
	EP701	E70225-003SS	EARTH PLATE	
	FW701	EMR3A8-20LST	FLAT WIRE A	
	FW801	EMR388-08SST	FLAT WIRE A	
	FW802	EMR378-08SST	FLAT WIRE A	
	TW701	QWE880-20RR	VINYL WIRE	BS
	TW701	QWE880-20RR	VINYL WIRE	EF
	TW701	QWE880-20RR	VINYL WIRE	EN
	TW701	QWE880-20RR	VINYL WIRE	G
	TW701	QWE880-20RR	VINYL WIRE	GI
	TW701	QWE880-20RR	VINYL WIRE	VX
	TW702	QWE881-17RR	PIN WIRE	BS
	TW702	QWE881-17RR	PIN WIRE	EF
	TW702	QWE881-17RR	PIN WIRE	EN
	TW702	QWE881-17RR	PIN WIRE	G
	TW702	QWE881-17RR	PIN WIRE	GI
	TW702	QWE881-17RR	PIN WIRE	VX
	TW812	EMT011-045	TERMINAL WI	
	TW813	EMT011-045	TERMINAL WI	BS
	TW813	EMT011-045	TERMINAL WI	EF
	TW813	EMT011-045	TERMINAL WI	EN
	TW813	EMT011-045	TERMINAL WI	G
	TW813	EMT011-045	TERMINAL WI	GI
	TW813	EMT011-045	TERMINAL WI	VX
	XT901	ECX0004-194KM	CERAMIC RES	
	X1021	ECX0000-400KS	CERAMIC RES	U
	X1021	ECX0000-400KS	CERAMIC RES	US
	X1021	ECX0000-400KS	CERAMIC RES	UT

Δ SAFETY PARTS

■ ENB-210 □ Tuner / CD Control, FL Display & Power Supply PC Board Ass'y

Note : ENB-210 □ varies according to the areas employed. See note (4) when placing an order.

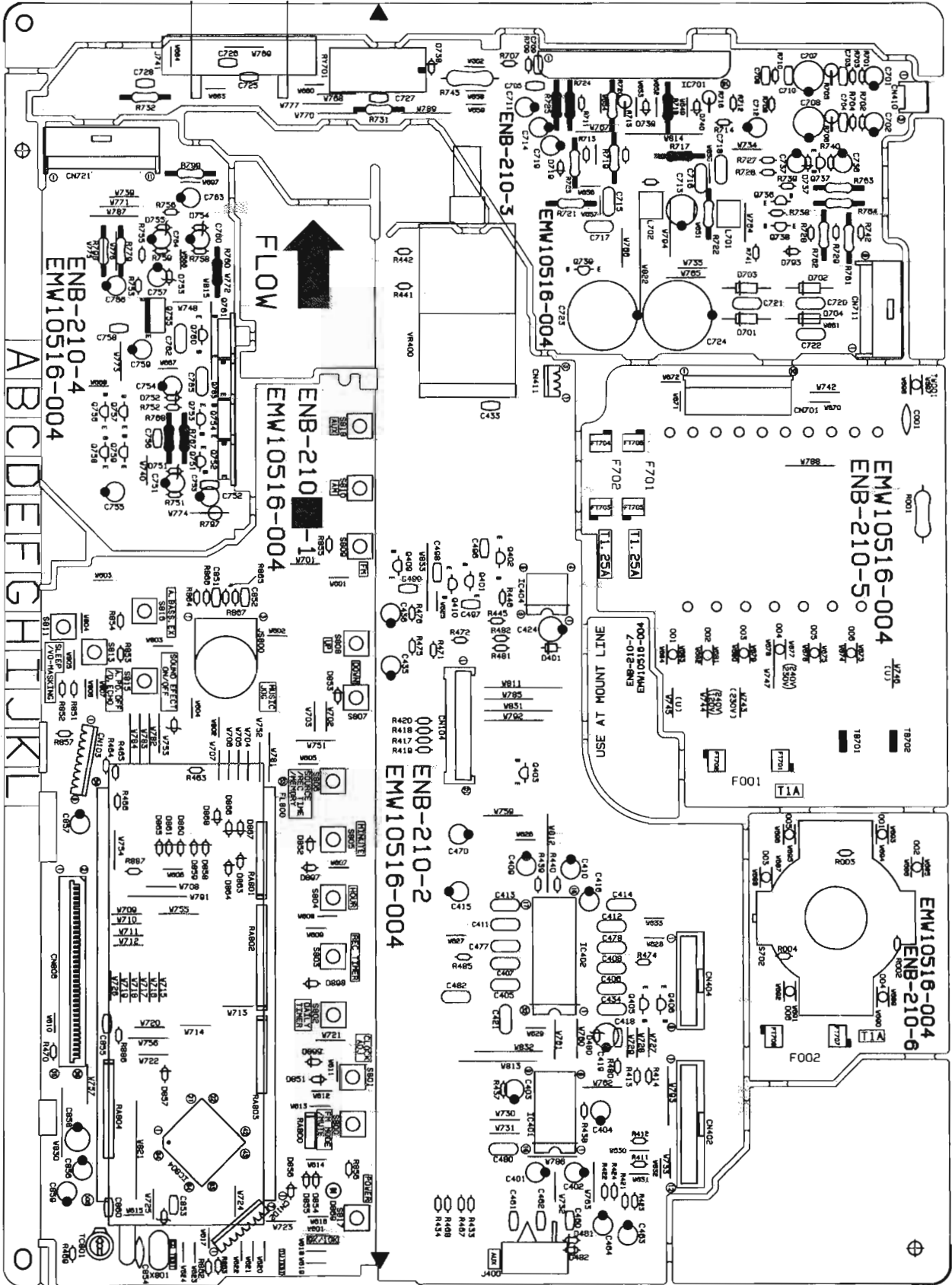

Note(4)

PC Board Ass'y	Designated Areas
ENB-210 A	U.S.A.,Canada
ENB-210 B	Singapore,Taiwan, Other Countries
ENB-210 C	Scandinavia,Germany,Italy Continental Europe
ENB-210 D	Eastern Europe
ENB-210 E	Austraria
ENB-210 F	the U.K.

TRANSISTORS

Δ ITEM	PART NUMBER	DESCRIPTION	AREA
Q401	2SD2144S(VW)	SI.TRANSIST ROHM	
Q402	2SD2144S(VW)	SI.TRANSIST ROHM	
Q403	DTA144ES	DIGITAL TRA ROHM	
Q405	DTC144ES	DIGITAL TRA ROHM	
Q406	DTC144ES	DIGITAL TRA ROHM	
Q409	2SD2144S(VW)	SI.TRANSIST ROHM	
Q410	2SD2144S(VW)	SI.TRANSIST ROHM	
Q736	2SC3311A(Q,R)	SI.TRANSIST MATSUSHITA	
Q737	2SC3311A(Q,R)	SI.TRANSIST MATSUSHITA	
Q738	2SA933S(RS)	SI.TRANSIST	
Q739	2SC3311A(Q,R)	SI.TRANSIST MATSUSHITA	
Q751	2SC3311A(Q,R)	SI.TRANSIST MATSUSHITA	
Q752	2SD2061(F,G)	SI.TRANSIST ROHM	
Q753	2SC3311A(Q,R)	SI.TRANSIST MATSUSHITA	
Q754	2SD2061(F,G)	SI.TRANSIST ROHM	
Q755	2SD2037(E,F)	SI.TRANSIST ROHM	
Q756	DTC144ES	DIGITAL TRA ROHM	
Q757	DTA144ES	DIGITAL TRA ROHM	
Q758	DTA144ES	DIGITAL TRA ROHM	
Q759	DTC144ES	DIGITAL TRA ROHM	
Q760	2SC3311A(Q,R)	SI.TRANSIST MATSUSHITA	
Q761	2SD2061(F,G)	SI.TRANSIST ROHM	
Q763	2SB1187(F,G)	SI.TRANSIST ROHM	

Δ SAFETY PARTS

I.C.S

Δ ITEM	PART NUMBER	DESCRIPTION	AREA
IC401	TC4052BP	I.C(DIGI-MO TOSHIBA	
IC402	M62417SP	I.C(M) MITSUBISHI	
IC404	LB1639-CV	I.C(DIGI-OT SANYO	
IC701	STK4141MK5	I.C(HYBRID) SANYO	
IC804	MN172412J521	I.C(MICRO-C MATSUSHITA	

Δ SAFETY PARTS

DIODES

Δ ITEM	PART NUMBER	DESCRIPTION	AREA
D401	1SR35-100	SI.DIODE ROHM	
D480	MTZ5.1JB	ZENER DIODE ROHM	
D481	1SS119	SI.DIODE	
D482	1SS119	SI.DIODE	
D701	10E2-FD	DIODE NIHONINTER	
D702	10E2-FD	DIODE NIHONINTER	
D703	10E2-FD	DIODE NIHONINTER	
D704	10E2-FD	DIODE NIHONINTER	
D719	1SS119	SI.DIODE	
D737	1SS119	SI.DIODE	
D738	1SS119	SI.DIODE	
D739	1SS119	SI.DIODE	
D740	1SS119	SI.DIODE	
D751	MTZ11JC	ZENER DIODE ROHM	
D752	MTZ6.8JC	ZENER DIODE ROHM	
D753	MTZ13JA	ZENER DIODE ROHM	
D754	MTZ9.1JB	ZENER DIODE ROHM	
D755	MTZ8.2JC	ZENER DIODE ROHM	
D793	1SS119	SI.DIODE	
D851	1SS119	SI.DIODE	

Δ SAFETY PARTS

DIODES

Δ ITEM	PART NUMBER	DESCRIPTION	AREA
D852	1SS119	SI.DIODE	
D853	1SS119	SI.DIODE	
D854	1SS119	SI.DIODE	A
D854	1SS119	SI.DIODE	BS
D854	1SS119	SI.DIODE	C
D854	1SS119	SI.DIODE	EF
D854	1SS119	SI.DIODE	EN
D854	1SS119	SI.DIODE	G
D854	1SS119	SI.DIODE	GI
D854	1SS119	SI.DIODE	J
D855	1SS119	SI.DIODE	A
D855	1SS119	SI.DIODE	BS
D855	1SS119	SI.DIODE	EF
D855	1SS119	SI.DIODE	EN
D855	1SS119	SI.DIODE	G
D855	1SS119	SI.DIODE	GI
D855	1SS119	SI.DIODE	U
D855	1SS119	SI.DIODE	US
D855	1SS119	SI.DIODE	UT
D856	1SS119	SI.DIODE	BS
D856	1SS119	SI.DIODE	C
D856	1SS119	SI.DIODE	EF
D856	1SS119	SI.DIODE	EN
D856	1SS119	SI.DIODE	G
D856	1SS119	SI.DIODE	GI
D856	1SS119	SI.DIODE	J
D856	1SS119	SI.DIODE	VX
D857	1SS119	SI.DIODE	
D858	1SS119	SI.DIODE	
D859	1SS119	SI.DIODE	
D860	1SS119	SI.DIODE	
D861	1SS119	SI.DIODE	
D863	1SS119	SI.DIODE	
D864	1SS119	SI.DIODE	
D865	1SS119	SI.DIODE	
D866	1SS119	SI.DIODE	ㄐㄐㄐ
D867	1SS119	SI.DIODE	ㄐㄐㄐ
D868	1SS119	SI.DIODE	ㄐㄐㄐ
D869	SLA-380LT	L.E.D. ROHM	BS
D869	SLR-342VC3F	L.E.D. ROHM	A
D869	SLR-342VC3F	L.E.D. ROHM	C
D869	SLR-342VC3F	L.E.D. ROHM	EF
D869	SLR-342VC3F	L.E.D. ROHM	EN
D869	SLR-342VC3F	L.E.D. ROHM	G
D869	SLR-342VC3F	L.E.D. ROHM	GI
D869	SLR-342VC3F	L.E.D. ROHM	J
D869	SLR-342VC3F	L.E.D. ROHM	U
D869	SLR-342VC3F	L.E.D. ROHM	US
D869	SLR-342VC3F	L.E.D. ROHM	UT
D869	SLR-342VC3F	L.E.D. ROHM	VX
D897	1SS119	SI.DIODE	ㄐㄐㄐ
D898	1SS119	SI.DIODE	ㄐㄐㄐ
D899	1SS119	SI.DIODE	ㄐㄐㄐ

Δ SAFETY PARTS

CAPACITORS

Δ ITEM	PART NUMBER	DESCRIPTION	AREA
C001	QCF21HP-223A	0.022MF 50V CER.CAPACI	BS
C001	QCF21HP-223A	0.022MF 50V CER.CAPACI	EF
C001	QCF21HP-223A	0.022MF 50V CER.CAPACI	EN
C001	QCF21HP-223A	0.022MF 50V CER.CAPACI	G
C001	QCF21HP-223A	0.022MF 50V CER.CAPACI	GI
C001	QCF21HP-223A	0.022MF 50V CER.CAPACI	VX
C401	QETB1CM-476	47MF 16V AL E.CAPAC	
C402	QETB1CM-476	47MF 16V AL E.CAPAC	
C403	QETB1HM-106	10MF 50V E.CAPACITO	
C404	QETB1HM-106	10MF 50V E.CAPACITO	
C405	QFV71HJ-683ZM	0.068MF 50V THIN FILM	
C406	QFV71HJ-683ZM	0.068MF 50V THIN FILM	
C407	QFV71HJ-184ZM	0.18MF 50V CAPACITOR	
C408	QFV71HJ-184ZM	0.18MF 50V CAPACITOR	
C409	QETB1HM-106	10MF 50V E.CAPACITO	
C410	QETB1HM-106	10MF 50V E.CAPACITO	
C411	QFV71HJ-474ZM	0.47MF 50V THIN FILM	
C412	QFV71HJ-474ZM	0.47MF 50V THIN FILM	
C413	QFV71HJ-683ZM	0.068MF 50V THIN FILM	
C414	QFV71HJ-683ZM	0.068MF 50V THIN FILM	
C415	QETB1HM-105	1MF 50V AL E.CAPAC	
C416	QETB1HM-105	1MF 50V AL E.CAPAC	
C418	QCBBIHK-561Y	560PF 50V CER.CAPACI	
C419	QETB1AM-107	100MF 10V AL E.CAPAC	
C421	QFV81HJ-103	0.01MF 50V THIN FILM	
C424	QETB1AM-107	100MF 10V AL E.CAPAC	
C433	QCVB1CM-103Y	0.01MF 16V CER.CAPACI	
C434	QFV81HJ-104	0.1MF 50V THIN FILM	
C435	QETB1HM-474	0.47MF 50V ELECTRO	
C436	QETB1HM-474	0.47MF 50V ELECTRO	
C460	QCHB1EZ-223	0.022MF 25V CER.CAPACI	
C461	QCBBIHK-471Y	470PF 50V CER.CAPACI	BS
C461	QCBBIHK-471Y	470PF 50V CER.CAPACI	EF

Δ SAFETY PARTS

CAPACITORS

Δ	ITEM	PART NUMBER	DESCRIPTION			AREA
	C461	QCBB1HK-471Y	470PF	50V	CER.CAPACI	EN
	C461	QCBB1HK-471Y	470PF	50V	CER.CAPACI	G
	C461	QCBB1HK-471Y	470PF	50V	CER.CAPACI	GI
	C461	QCBB1HK-471Y	470PF	50V	CER.CAPACI	U
	C461	QCBB1HK-471Y	470PF	50V	CER.CAPACI	US
	C461	QCBB1HK-471Y	470PF	50V	CER.CAPACI	UT
	C461	QC3B1HK-471Y	470PF	50V	CER.CAPACI	VX
	C462	QCBB1HK-471Y	470PF	50V	CER.CAPACI	BS
	C462	QCBB1HK-471Y	470PF	50V	CER.CAPACI	EF
	C462	QC3B1HK-471Y	470PF	50V	CER.CAPACI	EN
	C462	QCBB1HK-471Y	470PF	50V	CER.CAPACI	G
	C462	QCBB1HK-471Y	470PF	50V	CER.CAPACI	GI
	C462	QCBB1HK-471Y	470PF	50V	CER.CAPACI	U
	C462	QCBB1HK-471Y	470PF	50V	CER.CAPACI	US
	C462	QCBB1HK-471Y	470PF	50V	CER.CAPACI	UT
	C462	QCBB1HK-471Y	470PF	50V	CER.CAPACI	VX
	C463	QETB1CM-226	22MF	16V	E.CAPACITO	
	C464	QETB1CM-226	22MF	16V	E.CAPACITO	
	C470	QETB1HM-105	10MF	50V	AL E.CAPAC	
	C477	QFN31HJ-332Z	3300PF	50V	MYLAR CAPA	
	C478	QFN31HJ-332Z	3300PF	50V	MYLAR CAPA	
	C480	QFN81HJ-103	0.01MF	50V	METAL.MYLA	
	C482	QFN81HJ-103	0.01MF	50V	METAL.MYLA	
	C496	QCBB1HK-102Y	1000PF	50V	CER.CAPACI	
	C497	QCBB1HK-102Y	1000PF	50V	CER.CAPACI	
	C498	QCBB1HK-102Y	1000PF	50V	CER.CAPACI	
	C499	QCBB1HK-102Y	1000PF	50V	CER.CAPACI	
	C701	QETB1HM-106	10MF	50V	E.CAPACITO	
	C702	QETB1HM-106	10MF	50V	E.CAPACITO	
	C703	QCBB1HK-471Y	470PF	50V	CER.CAPACI	C
	C703	QCBB1HK-471Y	470PF	50V	CER.CAPACI	J
	C703	QCBB1HK-471Y	470PF	50V	CER.CAPACI	U
	C703	QCBB1HK-471Y	470PF	50V	CER.CAPACI	US
	C703	QCBB1HK-471Y	470PF	50V	CER.CAPACI	UT
	C704	QCBB1HK-471Y	470PF	50V	CER.CAPACI	C
	C704	QCBB1HK-471Y	470PF	50V	CER.CAPACI	J
	C704	QCBB1HK-471Y	470PF	50V	CER.CAPACI	U
	C704	QCBB1HK-471Y	470PF	50V	CER.CAPACI	US
	C704	QCBB1HK-471Y	470PF	50V	CER.CAPACI	UT
	C705	QCBB1HK-221Y	220PF	50V	CER.CAPACI	
	C706	QCBB1HK-221Y	220PF	50V	CER.CAPACI	
	C707	QETB1EM-476	47MF	25V	AL E.CAPAC	
	C708	QETB1EM-476	47MF	25V	AL E.CAPAC	
	C709	QCSB1HJ-100Y	10PF	50V	CER.CAPACI	
	C710	QCSB1HJ-100Y	10PF	50V	CER.CAPACI	
	C711	QETB1HM-226E	22MF	50V	E.CAPACITO	
	C712	QETB1HM-226E	22MF	50V	E.CAPACITO	
	C713	QETB1HM-107	100MF	50V	E.CAPACITO	
	C714	QETB1HM-106	10MF	50V	E.CAPACITO	
	C715	QFN81HJ-104	0.1MF	50V	METAL.MYLA	A
	C715	QFN81HJ-104	0.1MF	50V	METAL.MYLA	BS
	C715	QFN81HJ-104	0.1MF	50V	METAL.MYLA	EF
	C715	QFN81HJ-104	0.1MF	50V	METAL.MYLA	EN
	C715	QFN81HJ-104	0.1MF	50V	METAL.MYLA	G
	C715	QFN81HJ-104	0.1MF	50V	METAL.MYLA	GI
	C715	QFN81HJ-104	0.1MF	50V	METAL.MYLA	U
	C715	QFN81HJ-104	0.1MF	50V	METAL.MYLA	US
	C715	QFN81HJ-104	0.1MF	50V	METAL.MYLA	UT
	C715	QFN81HJ-104	0.1MF	50V	METAL.MYLA	VX
	C716	QFN81HJ-104	0.1MF	50V	METAL.MYLA	A
	C716	QFN81HJ-104	0.1MF	50V	METAL.MYLA	BS
	C716	QFN81HJ-104	0.1MF	50V	METAL.MYLA	EF
	C716	QFN81HJ-104	0.1MF	50V	METAL.MYLA	EN
	C716	QFN81HJ-104	0.1MF	50V	METAL.MYLA	EV
	C716	QFN81HJ-104	0.1MF	50V	METAL.MYLA	G
	C716	QFN81HJ-104	0.1MF	50V	METAL.MYLA	GI
	C716	QFN81HJ-104	0.1MF	50V	METAL.MYLA	U
	C716	QFN81HJ-104	0.1MF	50V	METAL.MYLA	US
	C716	QFN81HJ-104	0.1MF	50V	METAL.MYLA	UT
	C716	QFN81HJ-104	0.1MF	50V	METAL.MYLA	VX
	C717	QFN81HJ-104	0.1MF	50V	METAL.MYLA	
	C718	QFN81HJ-104	0.1MF	50V	METAL.MYLA	
	C719	QETB1HM-106	10MF	50V	E.CAPACITO	
	C720	QFN82AJ-103	0.01MF	100V	MYLAR CAPA	C
	C720	QFN82AJ-103	0.01MF	100V	MYLAR CAPA	J
	C720	QFN82AJ-103	0.01MF	100V	MYLAR CAPA	U
	C720	QFN82AJ-103	0.01MF	100V	MYLAR CAPA	US
	C720	QFN82AJ-103	0.01MF	100V	MYLAR CAPA	UT
	C720	QFN82AJ-104	0.1MF	100V	THIN FILM	A
	C720	QFN82AJ-104	0.1MF	100V	THIN FILM	BS
	C720	QFN82AJ-104	0.1MF	100V	THIN FILM	EF
	C720	QFN82AJ-104	0.1MF	100V	THIN FILM	EN
	C720	QFN82AJ-104	0.1MF	100V	THIN FILM	G
	C720	QFN82AJ-104	0.1MF	100V	THIN FILM	GI
	C720	QFN82AJ-104	0.1MF	100V	THIN FILM	VX
	C721	QFN82AJ-103	0.01MF	100V	MYLAR CAPA	C
	C721	QFN82AJ-103	0.01MF	100V	MYLAR CAPA	J
	C721	QFN82AJ-103	0.01MF	100V	MYLAR CAPA	U
	C721	QFN82AJ-103	0.01MF	100V	MYLAR CAPA	US
	C721	QFN82AJ-103	0.01MF	100V	MYLAR CAPA	UT
	C721	QFN82AJ-104	0.1MF	100V	THIN FILM	A
	C721	QFN82AJ-104	0.1MF	100V	THIN FILM	BS
	C721	QFN82AJ-104	0.1MF	100V	THIN FILM	EF
	C721	QFN82AJ-104	0.1MF	100V	THIN FILM	EN
	C721	QFN82AJ-104	0.1MF	100V	THIN FILM	G

Δ SAFETY PARTS

CAPACITORS

Δ	ITEM	PART NUMBER	DESCRIPTION			AREA
	C721	QFN82AJ-104	0.1MF	100V	THIN FILM	GI
	C721	QFN82AJ-104	0.1MF	100V	THIN FILM	VX
	C722	QFN82AJ-103	0.01MF	100V	MYLAR CAPA	C
	C722	QFN82AJ-103	0.01MF	100V	MYLAR CAPA	J
	C722	QFN82AJ-103	0.01MF	100V	MYLAR CAPA	U
	C722	QFN82AJ-103	0.01MF	100V	MYLAR CAPA	US
	C722	QFN82AJ-103	0.01MF	100V	MYLAR CAPA	UT
	C722	QFN82AJ-104	0.1MF	100V	THIN FILM	A
	C722	QFN82AJ-104	0.1MF	100V	THIN FILM	BS
	C722	QFN82AJ-104	0.1MF	100V	THIN FILM	EF
	C722	QFN82AJ-104	0.1MF	100V	THIN FILM	EN
	C722	QFN82AJ-104	0.1MF	100V	THIN FILM	G
	C722	QFN82AJ-104	0.1MF	100V	THIN FILM	GI
	C722	QFN82AJ-104	0.1MF	100V	THIN FILM	VX
	C723	EET4202-228E	2200MF		E.CAPACITO	A
	C723	EET4202-228E	2200MF		E.CAPACITO	BS
	C723	EET4202-228E	2200MF		E.CAPACITO	EF
	C723	EET4202-228E	2200MF		E.CAPACITO	EN
	C723	EET4202-228E	2200MF		E.CAPACITO	G
	C723	EET4202-228E	2200MF		E.CAPACITO	GI
	C723	EET4202-228E	2200MF		E.CAPACITO	U
	C723	EET4202-228E	2200MF		E.CAPACITO	US
	C723	EET4202-228E	2200MF		E.CAPACITO	UT
	C723	EET4202-228E	2200MF		E.CAPACITO	VX
	C723	EET4202-338E	3300MF		E.CAPACITO	C
	C723	EET4202-338E	3300MF		E.CAPACITO	J
	C724	EET4202-228E	2200MF		E.CAPACITO	A
	C724	EET4202-228E	2200MF		E.CAPACITO	BS
	C724	EET4202-228E	2200MF		E.CAPACITO	EF
	C724	EET4202-228E	2200MF		E.CAPACITO	EN
	C724	EET4202-228E	2200MF		E.CAPACITO	G
	C724	EET4202-228E	2200MF		E.CAPACITO	GI
	C724	EET4202-228E	2200MF		E.CAPACITO	U
	C724	EET4202-228E	2200MF		E.CAPACITO	US
	C724	EET4202-228E	2200MF		E.CAPACITO	UT
	C724	EET4202-228E	2200MF		E.CAPACITO	VX
	C724	EET4202-338E	3300MF		E.CAPACITO	C
	C724	EET4202-338E	3300MF		E.CAPACITO	J
	C725	QCXB1CM-222Y	2200PF	16V	CER.CAPACI	A
	C725	QCXB1CM-222Y	2200PF	16V	CER.CAPACI	BS
	C725	QCXB1CM-222Y	2200PF	16V	CER.CAPACI	EF
	C725	QCXB1CM-222Y	2200PF	16V	CER.CAPACI	EN
	C725	QCXB1CM-222Y	2200PF	16V	CER.CAPACI	G
	C725	QCXB1CM-222Y	2200PF	16V	CER.CAPACI	GI
	C725	QCXB1CM-222Y	2200PF	16V	CER.CAPACI	VX
	C726	QCXB1CM-222Y	2200PF	16V	CER.CAPACI	A
	C726	QCXB1CM-222Y	2200PF	16V	CER.CAPACI	BS
	C726	QCXB1CM-222Y	2200PF	16V	CER.CAPACI	EF
	C726	QCXB1CM-222Y	2200PF	16V	CER.CAPACI	EN
	C726	QCXB1CM-222Y	2200PF	16V	CER.CAPACI	G
	C726	QCXB1CM-222Y	2200PF	16V	CER.CAPACI	GI
	C726	QCXB1CM-222Y	2200PF	16V	CER.CAPACI	VX
	C727	QCHB1EZ-223	0.022MF	25V	CER.CAPACI	A
	C727	QCHB1EZ-223	0.022MF	25V	CER.CAPACI	BS
	C727	QCHB1EZ-223	0.022MF	25V	CER.CAPACI	EF
	C727	QCHB1EZ-223	0.022MF	25V	CER.CAPACI	EN
	C727	QCHB1EZ-223	0.022MF	25V	CER.CAPACI	G
	C727	QCHB1EZ-223	0.022MF	25V	CER.CAPACI	GI
	C727	QCHB1EZ-223	0.022MF	25V	CER.CAPACI	VX
	C728	QCHB1EZ-223	0.022MF	25V	CER.CAPACI	A
	C728	QCHB1EZ-223	0.022MF	25V	CER.CAPACI	BS
	C728	QCHB1EZ-223	0.022MF	25V	CER.CAPACI	EF
	C728	QCHB1EZ-223	0.022MF	25V	CER.CAPACI	EN
	C728	QCHB1EZ-223	0.022MF	25V	CER.CAPACI	GI
	C736	QETB1CM-476	47MF	16V	AL E.CAPAC	
	C737	QETB1CM-226	22MF	16V	E.CAPACITO	
	C751	QETB1CM-226	22MF	16V	E.CAPACITO	
	C752	QETB1CM-226	22MF	16V	E.CAPACITO	
	C753	QCVB1CM-103Y	0.01MF	16V	CER.CAPACI	
	C754	QETB1CM-226	22MF	16V	E.CAPACITO	
	C755	QETB1CM-226	22MF	16V	E.CAPACITO	
	C756	QCVB1CM-103Y	0.01MF	16V	CER.CAPACI	
	C757	QETB1CM-226	22MF	16V	E.CAPACITO	
	C758	QCVB1CM-103Y	0.01MF	16V	CER.CAPACI	
	C759	QETB1CM-226	22MF	16V	E.CAPACITO	
	C760	QETB1CM-226	22MF	16V	E.CAPACITO	
	C762	QFN81HJ-103	0.01MF	50V	METAL.MYLA	
	C763	QETB1CM-226	22MF	16V	E.CAPACITO	
	C764	QETB1CM-226	22MF	16V	E.CAPACITO	
	C765	QFN81HJ-103	0.01MF	50V	METAL.MYLA	
	C766	QETB1CM-226	22MF	16V	E.CAPACITO	
	C851	QCHB1EZ-223	0.022MF	25V	CER.CAPACI	
	C852	QCHB1EZ-223	0.022MF	25V	CER.CAPACI	
	C853	QCFB1HZ-104Y	0.1MF	50V	CER.CAPACI	
	C854	QCT26CH-330	33PF	50V	CER.CAPACI	
	C855	QCVB1CM-103Y	0.01MF	16V	CER.CAPACI	
	C856	QETB1HM-475E	4.7MF	50V	E.CAPACITO	
	C857	QETB1HM-475E	4.7MF	50V	E.CAPACITO	
	C858	QETB1HM-476	47MF	50V	E.CAPACITO	
	C859	QETB1AM-107	100MF	10V	AL E.CAPAC	
	C860	QCVB1CM-103Y	0.01MF	16V	CER.CAPACI	
	TC801	ENZ1003-015	0.1MF		TRIMMER CA	

Δ SAFETY PARTS

RESISTORS

Δ	ITEM	PART NUMBER	DESCRIPTION		AREA
Δ	R001	QRC128K-275EM	2.7M	1/2W COMPOSITIO	C
Δ	R001	QRC128K-275EM	2.7M	1/2W COMPOSITIO	J
Δ	R002	QRD161J-104	100K	1/6W CARBON RES	U
Δ	R002	QRD161J-104	100K	1/6W CARBON RES	US
Δ	R002	QRD161J-104	100K	1/6W CARBON RES	UT
Δ	R003	QRD161J-104	100K	1/6W CARBON RES	U
Δ	R003	QRD161J-104	100K	1/6W CARBON RES	US
Δ	R003	QRD161J-104	100K	1/6W CARBON RES	UT
Δ	R004	QRD161J-104	100K	1/6W CARBON RES	U
Δ	R004	QRD161J-104	100K	1/6W CARBON RES	US
Δ	R004	QRD161J-104	100K	1/6W CARBON RES	UT
Δ	R411	QRD167J-272	2.7K	1/6W CARBON RES	U
Δ	R412	QRD167J-272	2.7K	1/6W CARBON RES	US
Δ	R413	QRD161J-103	10K	1/6W CARBON RES	U
Δ	R414	QRD161J-103	10K	1/6W CARBON RES	US
Δ	R417	QRD161J-122	1.2K	1/6W CARBON RES	U
Δ	R418	QRD161J-122	1.2K	1/6W CARBON RES	US
Δ	R419	QRD161J-222	2.2K	1/6W CARBON RES	U
Δ	R420	QRD161J-222	2.2K	1/6W CARBON RES	US
Δ	R421	QRD167J-272	2.7K	1/6W CARBON RES	U
Δ	R422	QRD167J-272	2.7K	1/6W CARBON RES	US
Δ	R423	QRD167J-682	6.8K	1/6W CARBON RES	U
Δ	R424	QRD167J-682	6.8K	1/6W CARBON RES	US
Δ	R433	QRD167J-223	22K	1/6W CARBON RES	U
Δ	R434	QRD167J-223	22K	1/6W CARBON RES	US
Δ	R437	QRD161J-104	100K	1/6W CARBON RES	U
Δ	R438	QRD161J-104	100K	1/6W CARBON RES	US
Δ	R439	QRD161J-471	470	1/6W CARBON RES	U
Δ	R440	QRD161J-471	470	1/6W CARBON RES	US
Δ	R441	QRD161J-203	20K	1/6W CARBON RES	U
Δ	R442	QRD161J-203	20K	1/6W CARBON RES	US
Δ	R445	QRD161J-103	10K	1/6W CARBON RES	U
Δ	R446	QRD161J-103	10K	1/6W CARBON RES	US
Δ	R463	QRD161J-331	330	1/6W CARBON RES	U
Δ	R464	QRD161J-331	330	1/6W CARBON RES	US
Δ	R465	QRD161J-331	330	1/6W CARBON RES	UT
Δ	R466	QRD161J-331	330	1/6W CARBON RES	U
Δ	R467	QRD161J-473	47K	1/6W CARBON RES	US
Δ	R468	QRD161J-473	47K	1/6W CARBON RES	U
Δ	R469	QRD161J-103	10K	1/6W CARBON RES	US
Δ	R470	QRD161J-104	100K	1/6W CARBON RES	U
Δ	R471	QRD161J-333	33K	1/6W CARBON RES	U
Δ	R472	QRD161J-333	33K	1/6W CARBON RES	US
Δ	R474	QRD161J-104	100K	1/6W CARBON RES	U
Δ	R474	QRD161J-104	100K	1/6W CARBON RES	US
Δ	R474	QRD161J-104	100K	1/6W CARBON RES	UT
Δ	R475	QRD167J-682	6.8K	1/6W CARBON RES	U
Δ	R476	QRD167J-682	6.8K	1/6W CARBON RES	US
Δ	R480	QRD161J-101	100	1/6W CARBON RES	U
Δ	R481	QRD161J-103	10K	1/6W CARBON RES	US
Δ	R482	QRD161J-103	10K	1/6W CARBON RES	UT
Δ	R485	QRD161J-474	470K	1/6W CARBON RES	U
Δ	R701	QRD161J-102	1K	1/6W CARBON RES	US
Δ	R702	QRD161J-102	1K	1/6W CARBON RES	U
Δ	R703	QRD161J-104	100K	1/6W CARBON RES	US
Δ	R704	QRD161J-104	100K	1/6W CARBON RES	U
Δ	R705	ERD004J-112Z	1.1K	CARBON RES	U
Δ	R706	ERD004J-112Z	1.1K	CARBON RES	US
Δ	R707	QRD161J-112	1.1K	1/6W CARBON RES	U
Δ	R708	QRD161J-112	1.1K	1/6W CARBON RES	US
Δ	R709	QRD161J-104	100K	1/6W CARBON RES	U
Δ	R710	QRD161J-104	100K	1/6W CARBON RES	US
Δ	R711	QRD161J-242	2.4K	1/6W CARBON RES	U
Δ	R712	QRD161J-242	2.4K	1/6W CARBON RES	US
Δ	R713	QRD161J-242	2.4K	1/6W CARBON RES	UT
Δ	R714	QRD161J-242	2.4K	1/6W CARBON RES	U
Δ	R715	QRX014J-R22	0.22	1W METAL FILM	C
Δ	R716	QRX014J-R22	0.22	1W METAL FILM	J
Δ	R717	QRD14CJ-101S	100	1/4W UNF. CARBON	C
Δ	R717	QRD14CJ-101S	100	1/4W UNF. CARBON	J
Δ	R717	QRZ0077-101	100	1/4W FUSIBLE RE	A
Δ	R717	QRZ0077-101	100	1/4W FUSIBLE RE	BS
Δ	R717	QRZ0077-101	100	1/4W FUSIBLE RE	EF
Δ	R717	QRZ0077-101	100	1/4W FUSIBLE RE	EN
Δ	R717	QRZ0077-101	100	1/4W FUSIBLE RE	G
Δ	R717	QRZ0077-101	100	1/4W FUSIBLE RE	GI
Δ	R717	QRZ0077-101	100	1/4W FUSIBLE RE	U
Δ	R717	QRZ0077-101	100	1/4W FUSIBLE RE	US
Δ	R717	QRZ0077-101	100	1/4W FUSIBLE RE	UT
Δ	R717	QRZ0077-101	100	1/4W FUSIBLE RE	VX
Δ	R718	QRD14CJ-100SX	10	1/4W UNF. CARBON	C
Δ	R718	QRD14CJ-100SX	10	1/4W UNF. CARBON	J
Δ	R718	QRZ0077-100	10	1/4W FUSIBLE RE	A
Δ	R718	QRZ0077-100	10	1/4W FUSIBLE RE	BS
Δ	R718	QRZ0077-100	10	1/4W FUSIBLE RE	EF
Δ	R718	QRZ0077-100	10	1/4W FUSIBLE RE	EN
Δ	R718	QRZ0077-100	10	1/4W FUSIBLE RE	G
Δ	R718	QRZ0077-100	10	1/4W FUSIBLE RE	GI
Δ	R718	QRZ0077-100	10	1/4W FUSIBLE RE	U
Δ	R718	QRZ0077-100	10	1/4W FUSIBLE RE	US
Δ	R718	QRZ0077-100	10	1/4W FUSIBLE RE	UT
Δ	R718	QRZ0077-100	10	1/4W FUSIBLE RE	VX
Δ	R719	QRD14CJ-222SX	2.2K	1/4W UNF. CARBON	C
Δ	R720	QRD14CJ-222SX	2.2K	1/4W UNF. CARBON	J

Δ SAFETY PARTS

RESISTORS

Δ	ITEM	PART NUMBER	DESCRIPTION		AREA
Δ	R721	QRD14CJ-100SX	10	1/4W UNF. CARBON	C
Δ	R722	QRD14CJ-100SX	10	1/4W UNF. CARBON	J
Δ	R723	QRD14CJ-222SX	2.2K	1/4W UNF. CARBON	C
Δ	R724	QRZ0077-100	10	1/4W FUSIBLE RE	A
Δ	R725	QRZ0077-100	10	1/4W FUSIBLE RE	BS
Δ	R726	QRD161J-472	4.7K	1/6W CARBON RES	EF
Δ	R727	QRD161J-104	100K	1/6W CARBON RES	EN
Δ	R728	QRD161J-104	100K	1/6W CARBON RES	GI
Δ	R729	QRD161J-823	82K	1/6W CARBON RES	VX
Δ	R731	QRD14CJ-4R7S	4.7	1/4W UNF. CARBON	A
Δ	R731	QRD14CJ-4R7S	4.7	1/4W UNF. CARBON	BS
Δ	R731	QRD14CJ-4R7S	4.7	1/4W UNF. CARBON	EF
Δ	R731	QRD14CJ-4R7S	4.7	1/4W UNF. CARBON	EN
Δ	R731	QRD14CJ-4R7S	4.7	1/4W UNF. CARBON	G
Δ	R731	QRD14CJ-4R7S	4.7	1/4W UNF. CARBON	GI
Δ	R731	QRD14CJ-4R7S	4.7	1/4W UNF. CARBON	VX
Δ	R732	QRD14CJ-4R7S	4.7	1/4W UNF. CARBON	A
Δ	R732	QRD14CJ-4R7S	4.7	1/4W UNF. CARBON	BS
Δ	R732	QRD14CJ-4R7S	4.7	1/4W UNF. CARBON	EF
Δ	R732	QRD14CJ-4R7S	4.7	1/4W UNF. CARBON	EN
Δ	R732	QRD14CJ-4R7S	4.7	1/4W UNF. CARBON	G
Δ	R732	QRD14CJ-4R7S	4.7	1/4W UNF. CARBON	GI
Δ	R732	QRD14CJ-4R7S	4.7	1/4W UNF. CARBON	VX
Δ	R738	QRD161J-104	100K	1/6W CARBON RES	U
Δ	R739	QRD161J-103	10K	1/6W CARBON RES	US
Δ	R740	QRD161J-104	100K	1/6W CARBON RES	U
Δ	R741	QRD161J-103	10K	1/6W CARBON RES	US
Δ	R742	QRD161J-222	2.2K	1/6W CARBON RES	U
Δ	R745	QRG022J-561A	560	2W OXIDE META	A
Δ	R751	QRD161J-222	2.2K	1/6W CARBON RES	BS
Δ	R752	QRD167J-272	2.7K	1/6W CARBON RES	EF
Δ	R753	QRD167J-152	1.5K	1/6W CARBON RES	EN
Δ	R755	QRD161J-472	4.7K	1/6W CARBON RES	G
Δ	R756	QRD167J-153	15K	1/6W CARBON RES	GI
Δ	R758	QRD161J-242	2.4K	1/6W CARBON RES	VX
Δ	R759	QRD161J-242	2.4K	1/6W CARBON RES	U
Δ	R760	QRZ0077-4R7	4.7	1/4W FUSE RESIS	A
Δ	R760	QRZ0077-4R7	4.7	1/4W FUSE RESIS	BS
Δ	R760	QRZ0077-4R7	4.7	1/4W FUSE RESIS	EF
Δ	R760	QRZ0077-4R7	4.7	1/4W FUSE RESIS	EN
Δ	R760	QRZ0077-4R7	4.7	1/4W FUSE RESIS	G
Δ	R760	QRZ0077-4R7	4.7	1/4W FUSE RESIS	GI
Δ	R760	QRZ0077-4R7	4.7	1/4W FUSE RESIS	U
Δ	R760	QRZ0077-4R7	4.7	1/4W FUSE RESIS	US
Δ	R760	QRZ0077-4R7	4.7	1/4W FUSE RESIS	UT
Δ	R760	QRZ0077-4R7	4.7	1/4W FUSE RESIS	VX
Δ	R761	QRD14CJ-681SX	680	1/4W UNF. CARBON	C
Δ	R762	QRD14CJ-681SX	680	1/4W UNF. CARBON	J
Δ	R763	QRD14CJ-681SX	680	1/4W UNF. CARBON	C
Δ	R764	QRD14CJ-681SX	680	1/4W UNF. CARBON	J
Δ	R767	QRD14CJ-8R2S	8.2	1/4W UNF. CARBON	C
Δ	R767	QRD14CJ-8R2S	8.2	1/4W UNF. CARBON	J
Δ	R767	QRZ0077-8R2	8.2	1/4W FUSIBLE	A
Δ	R767	QRZ0077-8R2	8.2	1/4W FUSIBLE	BS
Δ	R767	QRZ0077-8R2	8.2	1/4W FUSIBLE	EF
Δ	R767	QRZ0077-8R2	8.2	1/4W FUSIBLE	EN
Δ	R767	QRZ0077-8R2	8.2	1/4W FUSIBLE	G
Δ	R767	QRZ0077-8R2	8.2	1/4W FUSIBLE	GI
Δ	R767	QRZ0077-8R2	8.2	1/4W FUSIBLE	U
Δ	R767	QRZ0077-8R2	8.2	1/4W FUSIBLE	US
Δ	R767	QRZ0077-8R2	8.2	1/4W FUSIBLE	UT
Δ	R767	QRZ0077-8R2	8.2	1/4W FUSIBLE	VX
Δ	R768	QRD14CJ-8R2S	8.2	1/4W UNF. CARBON	C
Δ	R768	QRD14CJ-8R2S	8.2	1/4W UNF. CARBON	J
Δ	R768	QRZ0077-8R2	8.2	1/4W FUSIBLE	A
Δ	R768	QRZ0077-8R2	8.2	1/4W FUSIBLE	BS
Δ	R768	QRZ0077-8R2	8.2	1/4W FUSIBLE	EF
Δ	R768	QRZ0077-8R2	8.2	1/4W FUSIBLE	EN
Δ	R768	QRZ0077-8R2	8.2	1/4W FUSIBLE	G
Δ	R768	QRZ0077-8R2	8.2	1/4W FUSIBLE	GI
Δ	R768	QRZ0077-8R2	8.2	1/4W FUSIBLE	U
Δ	R768	QRZ0077-8R2	8.2	1/4W FUSIBLE	US
Δ	R768	QRZ0077-8R2	8.2	1/4W FUSIBLE	UT
Δ	R768	QRZ0077-8R2	8.2	1/4W FUSIBLE	VX
Δ	R779	QRD14CJ-2R2SX	2.2	1/4W UNF. CARBON	C
Δ	R779	QRD14CJ-2R2SX	2.2	1/4W UNF. CARBON	J
Δ	R797	QRX014J-R22	0.22	1W METAL FILM	C
Δ	R797	QRX014J-R22	0.22	1W METAL FILM	J
Δ	R798	QRD14CJ-2R2SX	2.2	1/4W UNF. CARBON	C
Δ	R798	QRD14CJ-2R2SX	2.2	1/4W UNF. CARBON	J
Δ	R799	QRD14CJ-2R2SX	2.2	1/4W UNF. CARBON	C
Δ	R799	QRD14CJ-2R2SX	2.2	1/4W UNF. CARBON	J
Δ	R851	QRD161J-222	2.2K	1/6W CARBON RES	U
Δ	R852	QRD161J-112	1.1K	1/6W CARBON RES	US
Δ	R853	QRD161J-681	680	1/6W CARBON RES	U
Δ	R854	QRD167J-431	430	1/6W CARBON RES	US
Δ	R855	QRD167J-431	430	1/6W CARBON RES	UT
Δ	R856	QRD161J-201	200	1/6W CARBON RES	A
Δ	R856	QRD161J-201	200	1/6W CARBON RES	C
Δ	R856	QRD161J-201	200	1/6W CARBON RES	EF
Δ	R856	QRD161J-201	200	1/6W CARBON RES	EN
Δ	R856	QRD161J-201	200	1/6W CARBON RES	G
Δ	R856	QRD161J-201	200	1/6W CARBON RES	GI
Δ	R856	QRD161J-201	200	1/6W CARBON RES	J

Δ SAFETY PARTS

RESISTORS

Δ	ITEM	PART NUMBER	DESCRIPTION	AREA
	R856	QRD161J-201	200 1/6W CARBON RES	U
	R856	QRD161J-201	200 1/6W CARBON RES	US
	R856	QRD161J-201	200 1/6W CARBON RES	UT
	R856	QRD161J-201	200 1/6W CARBON RES	VX
	R856	QRD161J-221	220 1/6W CARBON RES	BS
	R857	QRD161J-103	10K 1/6W CARBON RES	
	R862	QRD161J-103	10K 1/6W CARBON RES	
	R863	QRD161J-103	10K 1/6W CARBON RES	
	R864	QRD161J-103	10K 1/6W CARBON RES	
	R865	QRD161J-103	10K 1/6W CARBON RES	
	R866	QRD167J-223	22K 1/6W CARBON RES	
	R867	QRD167J-223	22K 1/6W CARBON RES	
	R886	QRD161J-473	47K 1/6W CARBON RES	
	R887	QRD161J-331	330 1/6W CARBON RES	
	RA800	QRB049J-222	2.2K 1/10W RESISTOR A	
	RA801	QRB109J-104	100K 1/10W NETWORK RE	
	VR400	QVDB71Z-E15CJ3	100K VARIABLE R	

Δ : SAFETY PARTS

OTHERS

Δ	ITEM	PART NUMBER	DESCRIPTION	AREA
	J741	EMB90TV-403A	SPEAKER TER	
	L701	EQL0011-R45J1	INDUCTOR	
	L702	EQL0011-R45J1	INDUCTOR	
	S702	QSR8001-E01U	ROTARY SWIT	U
	S702	QSR8001-E01U	ROTARY SWIT	US
	S702	QSR8001-E01U	ROTARY SWIT	UT
	S800	ESP0001-023M	TACT SWITCH	
	S801	ESP0001-023M	TACT SWITCH	
	S802	ESP0001-023M	TACT SWITCH	
	S803	ESP0001-023M	TACT SWITCH	
	S804	ESP0001-023M	TACT SWITCH	
	S805	ESP0001-023M	TACT SWITCH	
	S806	ESP0001-023M	TACT SWITCH	
	S807	ESP0001-023M	TACT SWITCH	
	S808	ESP0001-023M	TACT SWITCH	
	S809	ESP0001-023M	TACT SWITCH	
	S810	ESP0001-023M	TACT SWITCH	
	S811	ESP0001-023M	TACT SWITCH	
	S813	ESP0001-023M	TACT SWITCH	
	S815	ESP0001-023M	TACT SWITCH	
	S816	ESP0001-023M	TACT SWITCH	
	S817	ESP0001-023M	TACT SWITCH	
	S818	ESP0001-023M	TACT SWITCH	
	X801	ECX0006-000KNJ	CRYSTAL	
	CN102	EWS267-F93Z	SOCKET WIRE	
	CN103	EWS268-F925J	SOCKET WIRE	
	CN104	EMV5140-010	VOLUME SOCK	
	CN402	EMV7163-012	CONNECT TER	
	CN4C4	EMV7163-009	CONNECT TER	
	CN410	EMV5109-003B	CONNECT TER	
	CN411	EWS293-0135	SOCKET WIRE	
	CN701	VMC0107-R10	CONNECT TER	
	CN711	EMV5163-009R	CONNECT TER	
	CN721	EMV5163-011R	CONNECT TER	
	CN806	VMC0161-036	CONNECT TER	
	FL800	ELU0001-201	FLUORESCENT	
	FT701	VMZ0087-001Z	FUSE HOLDER	
	FT702	VMZ0087-001Z	FUSE HOLDER	
	FT703	VMZ0087-001Z	FUSE HOLDER	
	FT704	VMZ0087-001Z	FUSE HOLDER	
	FT705	VMZ0087-001Z	FUSE HOLDER	
	FT706	VMZ0087-001Z	FUSE HOLDER	
	FT707	VMZ0087-001Z	FUSE HOLDER	U
	FT707	VMZ0087-001Z	FUSE HOLDER	US
	FT707	VMZ0087-001Z	FUSE HOLDER	UT
	FT707	VMZ0087-001Z	FUSE HOLDER	U
	FT707	VMZ0087-001Z	FUSE HOLDER	US
	FT708	VMZ0087-001Z	FUSE HOLDER	US
	FT708	VMZ0087-001Z	FUSE HOLDER	UT
	JS800	QSJ4002-E02	PUSH SWITCH	
	RY701	ESK7D24-2120	RELAY	
	TB701	EMZ4001-001	TAB	
	TB702	EMZ4001-001	TAB	
	TW001	EWTO11-173	TERMINAL WI	BS
	TW001	EWTO11-173	TERMINAL WI	EF
	TW001	EWTO11-173	TERMINAL WI	EN
	TW001	EWTO11-173	TERMINAL WI	G
	TW001	EWTO11-173	TERMINAL WI	GI
	TW001	EWTO11-173	TERMINAL WI	VX
	WR001	QWE350-05BB	VINYL WIRE	

Δ : SAFETY PARTS

OTHERS

Δ	ITEM	PART NUMBER	DESCRIPTION	AREA
		EMW10516-004	CIRCUIT BOA	A
		EMW10516-004	CIRCUIT BOA	EF
		EMW10516-004	CIRCUIT BOA	EN
		EMW10516-004	CIRCUIT BOA	G
		EMW10516-004	CIRCUIT BOA	GI
		EMW10516-004	CIRCUIT BOA	U
		EMW10516-004	CIRCUIT BOA	US
		EMW10516-004	CIRCUIT BOA	UT
		EMW10516-004	CIRCUIT BOA	VX
		EMW10516-004BS	CIRCUIT BOA	BS
		EMW10516-104	CIRCUIT BOA	C
		EMW10516-104	CIRCUIT BOA	J
		E67132-T2R0	FUSE LABEL	U
		E67132-T2R0	FUSE LABEL	US
		E67132-T2R0	FUSE LABEL	UT
		QWE881-24RR	VINYL WIRE	U
		QWE881-24RR	VINYL WIRE	US
		QWE881-24RR	VINYL WIRE	UT
		QWE882-24RR	VINYL WIRE	U
		QWE882-24RR	VINYL WIRE	US
		QWE882-24RR	VINYL WIRE	UT
		QWE883-21RR	VINYL WIRE	U
		QWE883-21RR	VINYL WIRE	US
		QWE883-21RR	VINYL WIRE	UT
		QWE884-25RR	VINYL WIRE	U
		QWE884-25RR	VINYL WIRE	US
		QWE884-25RR	VINYL WIRE	UT
		QWE886-23RR	VINYL WIRE	U
		QWE886-23RR	VINYL WIRE	US
		QWE886-23RR	VINYL WIRE	UT
		QWE888-25RR	VINYL WIRE	U
		QWE888-25RR	VINYL WIRE	US
		QWE888-25RR	VINYL WIRE	UT
		VYH7653-001	SPRING	
	J400	EMN00TV-222AJ2	PIN JACK	

Δ : SAFETY PARTS

Accessories List

Symbol No.

M	5	M	M
---	---	---	---

Item	Part Number	Part Name	Q'ty	Description	Area
1	E30580-2260A	INSTRUCTION BOOK	1		A
	E30580-2260ABS	INSTRUCTION BOOK	1		BS
	E30580-2261A	INSTRUCTION BOOK	1		C,EF,G,GI
	E30580-2262A	INSTRUCTION BOOK	1		EN
	E30580-2263A	INSTRUCTION BOOK	1		VX
2	E30580-2264A	INSTRUCTION BOOK	1		U,US,UT
	E30580-2265B	INSTRUCTION BOOK	1		J
	ENZ2202-001	SIEMENS PLUG	1		US
3	ENZ2203-001	ADAPTOR PLUG	1		U,UT
	E03614-004	FM FEEDER ANTENNA	1		A,BS,C,EF,EN,GI,J,U,US,UT,VX
3	E67007-001	ANTENNA WIRE	1		G
	EQB4001-015	LOOP ANTENNA	1		
	EMZ2001-014	ADAPTOR PLUG	1		A,BS,C,EF,EN,GI,J,U,US,UT,VX
	RM-SEC330U	WIRE-LESS REMOTE CONTROL	1		
	R6PRPA-2ST	DRY CELL	2		
8	QPGA025-03505	POLY BAG	1		A,C,EF,EN,G,GI,U,US,UT,VX
	QPGA025-03505B	POLY BAG	1		BS,J
	BT-20025M	WARRANTY CARD	1		C
	BT-20044G	SAFETY SHEET	1		J
	BT-20066A	WARRANTY CARD	1		BS
-	BT-20071B	SERVICE NETWORK	1		C
	BT-20134	WARRANTY CARD	1		G
	BT-51006-1	REGISTER CARD	1		J
	BT-56001-1	WARRANTY CARD	1		A
	BT20060	WARRANTY CARD	1		BS
-	E43486-340A	SAFETY SHEET	1		BS

The Marks for Designated Areas

J	the U.S.A.	A	Australia	C	Canada	VX	East Europe
G	Germany	U	Universal	US	Singapore	UT	Taiwan
EF	Continental Europe	EN	Scandinavia	GI	Italy	BS	the U.K.

No mark indicates all area.

Packing Materials and Part Numbers

Symbol No.

M	6	M	M
---	---	---	---

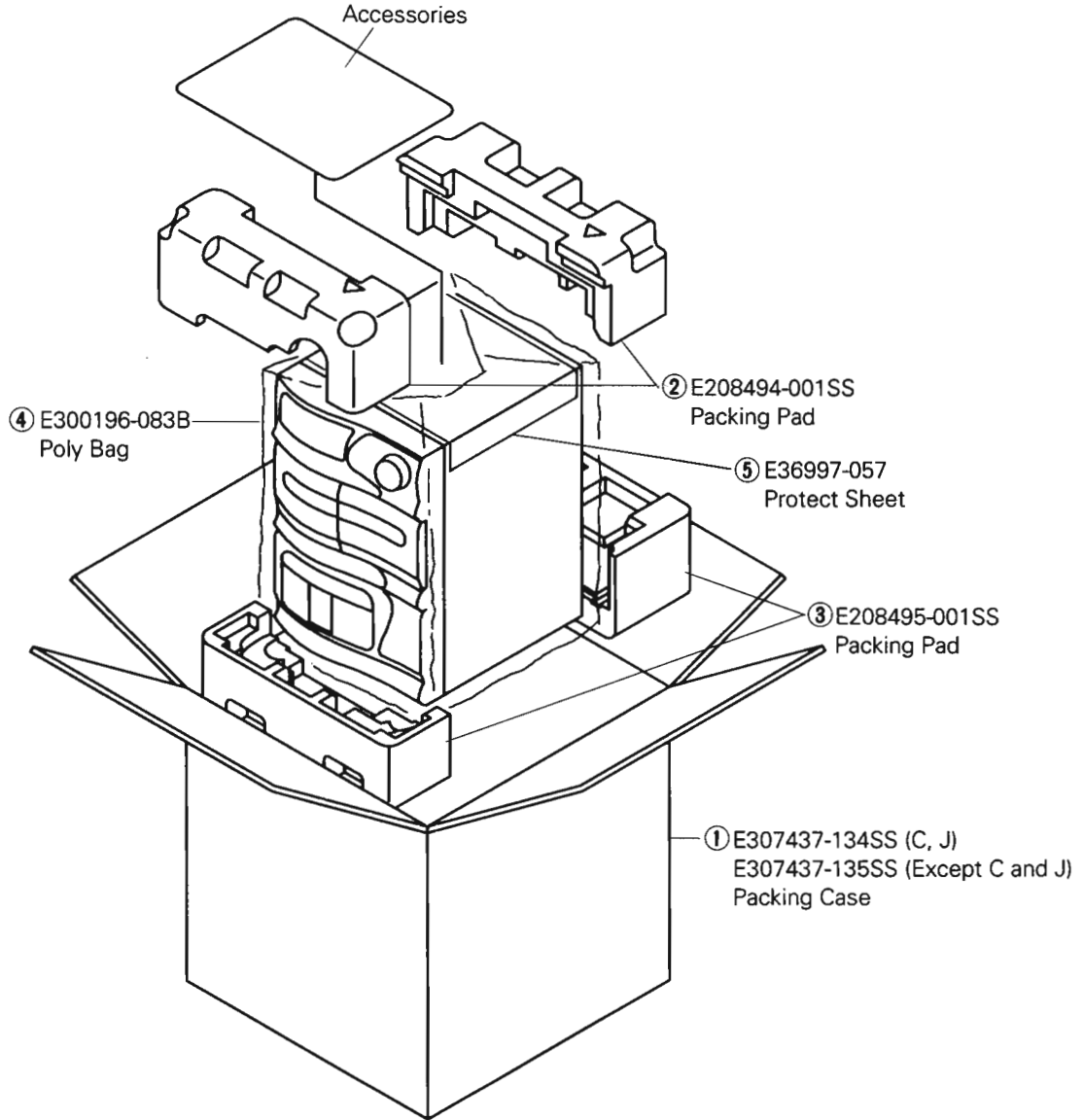

The Marks for Designated Areas			
J	the U.S.A.	
G	Germany	
EF	Continental Europe	
No mark indicates all area.			
A	Australia	
U	Universal	
EN	Scandinavia	
C	Canada	
US	Singapore	
GI	Italy	
VX	East Europe	
UT	Taiwan	
BS	the U.K.	

JVC

VICTOR COMPANY OF JAPAN, LIMITED
AUDIO DIVISION, YAMATO PLANT, 1644, SHIMOTSURUMA, YAMATO-SHI, KANAGAWA-KEN, 242, JAPAN

