

# JVC

## SERVICE MANUAL

### COMPACT COMPONENT SYSTEM

## CA-D4T

PICK UP	OPT-6S
Lsi	MN35510

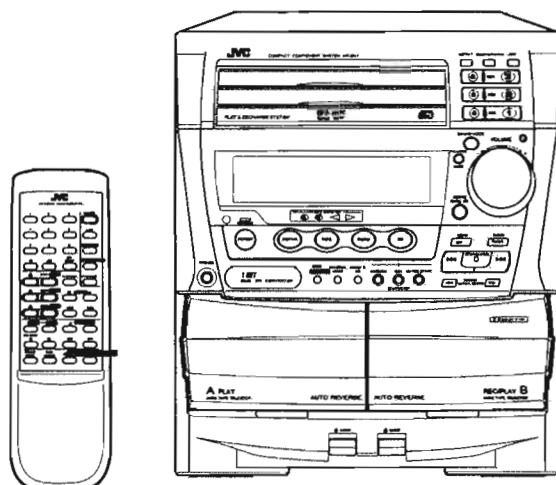

#### Area Suffix

J	.....	U.S.A
C	.....	Canada
A	.....	Australia
BS	.....	the U.K.
E	.....	Continental Europe
G	.....	Germany
GI	.....	Italy
VX	.....	East Europe
US	.....	Singapore
UT	.....	Taiwan
UC	.....	China
UB	.....	Hong Kong
U	.....	Other Area

### Contents

<i>Safety Precautions</i> .....	1-2	<i>Maintenance of Laser Pickup</i> .....	1-54
<i>Important for Laser Products</i> .....	1-3	<i>Replacement of Laser Pickup</i> .....	1-54
<i>Instruction Book</i> .....	1-4	<i>Block Diagrams</i> .....	1-55
<i>Description of Major LSIs</i> .....	1-21	<i>Schematic Diagrams</i> .....	1-57
<i>Internal Connection of FL Display Tube</i> ..	1-32	<i>Printed Circuit Boards</i> .....	1-65
<i>Disassembly Procedures</i> .....	1-34	<i>Parts List</i> .....	2-1
<i>Adjustment Procedures</i> .....	1-49		
<i>Flow of Functional Operation</i>			
<i>Until TOC is Read</i> .....	1-53		

COMPACT  
**disc**  
DIGITAL AUDIO

### **Safety Precautions**

1. The design of this product contains special hardware and many circuits and components specially for safety purposes. For continued protection, no changes should be made to the original design unless authorised in writing by the manufacturer. Replacement parts must be identical to those used in the original circuits.
2. Any unauthorised design alterations or additions will void the manufacturer's guarantee ; furthermore the manufacturer cannot accept responsibility for personal injury or property damage resulting therefrom.
3. Essential safety critical components are identified by (⚠) on the Parts List and by shading on the schematics ,and must never be replaced by parts other than those listed in the manual. Please note however that many electrical and mechanical parts in the product have special safety related characteristics . These characteristics are often not evident from visual inspection . Parts other than specified by the manufacturer may not have the same safety characteristics as the recommended replacement parts shown in the Parts List of the service manual and may create shock , fire , or other hazards .
4. The leads in the products are routed and dressed with ties, clamps, tubings, barriers and the like to be separated from live parts, high temperature parts, moving parts and/or sharp edges for the prevention of electric shock and fire hazard. When service is required, the original lead routing and dress should be observed, and it should be confirmed that they have been returned to normal, after re-assembling.

### **Warning**

1. Service should be performed by qualified personnel only.
2. This equipment has been designed and manufactured to meet international safety standards.
3. It is the legal responsibility of the repairer to ensure that these safety standards are maintained.
4. Repairs must be made in accordance with the relevant safety standards.
5. It is essential that safety critical components are replaced by approved parts.
6. If mains voltage selector is provided, check setting for local voltage .

# Important for Laser Products

1. **CLASS 1 LASER PRODUCT**
2. **DANGER** : Invisible laser radiation when open and interlock failed or defeated. Avoid direct exposure to beam.
3. **CAUTION** : There are no serviceable parts inside the Laser Unit. Do not disassemble the Laser Unit. Replace the complete Laser Unit if it malfunctions.
4. **CAUTION** : The compact disc player uses invisible laser radiation and is equipped with safety switches which prevent emission of radiation when the drawer is open and the safety interlocks have failed or are defeated. It is dangerous to defeat the safety switches.
5. **CAUTION** : If safety switches malfunction, the laser is able to function.
6. **CAUTION** : Use of controls, adjustments or performance of procedures other than those specified herein may result in hazardous radiation exposure.

**VARNING** : Osynlig laserstrålning när denna del är öppnad och spärren är urkopplad. Betrakta ej strålen.

**VARO** : Avattaessa ja suojalukitus ohitettaessa olet alttiina näkymättömälle lasersäteilylle. Älä katso säteeseen.

**ADVARSEL** : Usynlig laserstrålning ved åbning, når sikkerhedsafbrydere er ude af funktion. Undgå udsættelse for stråling.

**ADVARSEL** : Usynlig laserstrålning ved åbning, når sikkerhedsbryteren er avslott. unngå utsettelse for stråling.

## REPRODUCTION AND POSITION OF LABELS

CLASS 1  
LASER PRODUCT

**CLASSIFICATION LABEL**  
(Except for the U. S. A. and Canada)

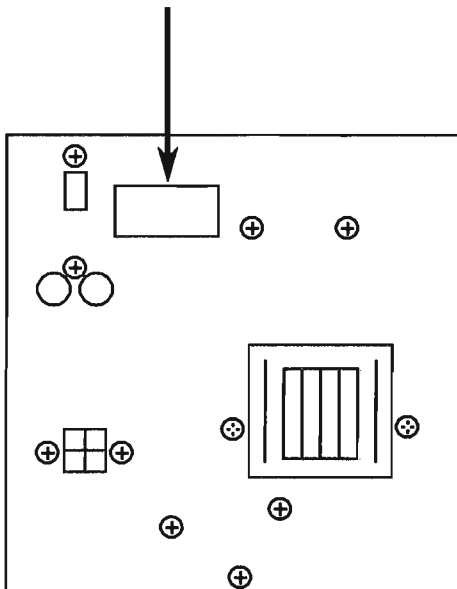

## WARNING LABEL

(Except for the U. S. A.)

**DANGER**: invisible laser radiation when open and interlock failed or defeated. AVOID DIRECT EXPOSURE TO BEAM. (e)

**VARNING**: Osynlig laserstrålning när denna del är öppnad och spärren är urkopplad. Betrakta ej strålen. (s)

**ADVARSEL**: Usynlig laserstrålning ved åbning, når sikkerhedsafbrydere er ude af funktion. Undgå udsættelse for stråling. (d)

**VARO**: Avattaessa ja suojalukitus ohitettaessa olet alttiina näkymättömälle lasersäteilylle. Älä katso säteeseen. (f)

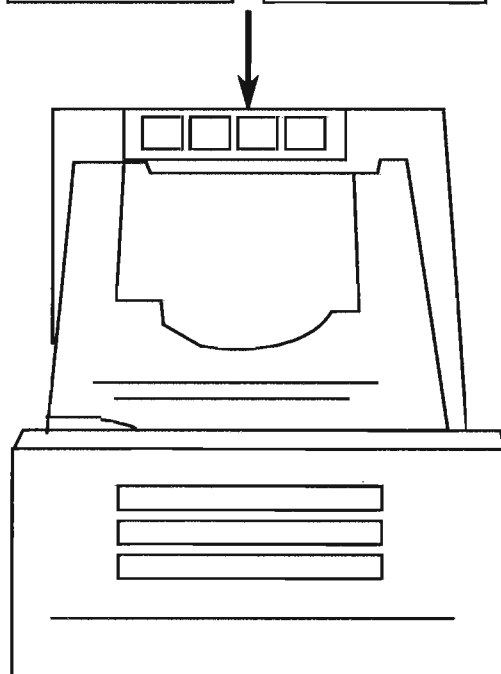

# Instruction Book

## Specifications

<b>Amplifier Section</b>	
Output Power	70 watts per channel, Min. RMS at 6 ohms, from 60 Hz to 20 kHz, with no more than 0.9% Total Harmonic Distortion.
Input Sensitivity/Impedance (1 kHz)	300 mV/50 kohms
AUX	
Speaker terminals	6 - 16 ohms
Main speakers	
<b>Cassette Deck Section</b>	
Frequency Response	30 - 16,000 Hz
Type II (CrO <sub>2</sub> ) :	30 - 15,000 Hz
Type I (NORMAL) :	0.15% (WRMS)
Wow And Flutter	
<b>CD Automatic Changer Section</b>	
CD Capacity	3 discs
Dynamic Range	90 dB
Signal-To-Noise Ratio	90 dB
Wow And Flutter	Unmeasurable
<b>Tuner Section</b>	
FM Tuner	
Tuning Range	87.5 - 108.0 MHz
AM Tuner	
Tuning Range	530 - 1,710 kHz
Dimensions	245 x 285 x 348 mm (W/H/D) (9-11/16 x 11-1/4 x 13-3/4 inches)
Mass	7.7 kg (17.0 lbs)
<b>Accessories</b>	
AM Loop Antenna	(1)
Remote Control	(1)
Batteries R6P (SUM-3)/AAA (15F)	(2)
FM Wire Antenna	(1)
<b>Power Specifications</b>	
Power Requirements	AC 120 V $\sim$ , 60 Hz
Power Consumption	115 watts
	16 watts (in standby mode)

*Design and specifications are subject to change without notice.*

## Getting Started

### Accessories

Check to be sure you have all of the following things, which are supplied with the CA-D4T:

- AM Loop Antenna (1)
- Remote Control (1)
- Batteries (2)
- FM Wire Antenna (1)

If any are missing, contact your dealer immediately.

### How To Put Batteries in the Remote Control

Match the polarity (+ and -) on the batteries with the + and - markings in the battery compartment.

R6P (SUM-3)/AAA (15F)

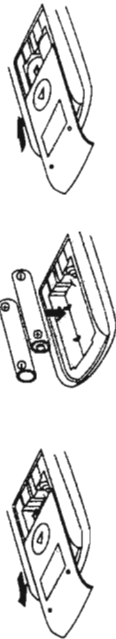

**CAUTION:** Handle batteries properly.

To avoid battery leakage or explosion:

- Remove batteries when the Remote Control will not be used for a long time.
- When you need to replace the batteries, replace both batteries at the same time with new ones.
- Don't use an old battery with a new one.
- Don't use different types of batteries together.

### Using the Remote Control

The Remote Control makes it easy to use many of the functions of the CA-D4T from a distance of up to 7 m (23 feet) away. You need to point the Remote Control at the remote sensor on the CA-D4T's front panel.

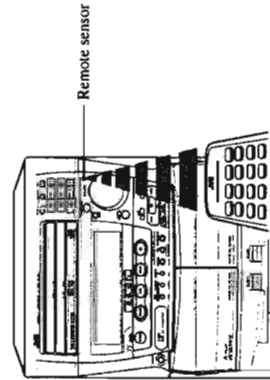

**CAUTION:** Make all connections before plugging the Unit into an AC power outlet.

### Connecting the FM Antenna

#### Using the Supplied Feeder Antenna

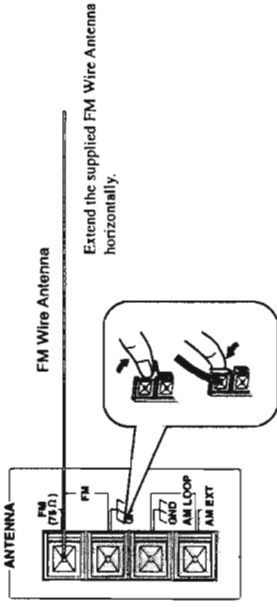

#### Using an FM 75-Ohm Antenna Cable (Not Supplied)

If reception is poor, connect the outside antenna.

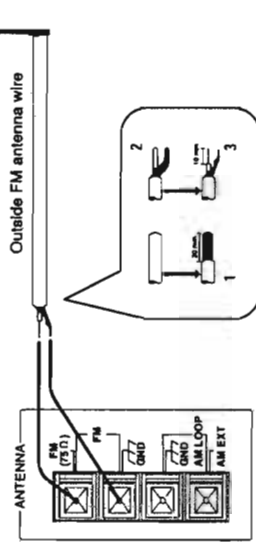

Before attaching a 75 ohm coaxial lead (the kind with a round wire going to an outside antenna), disconnect the supplied FM Wire Antenna.

**CAUTION:** To avoid noise, keep antennas away from metallic parts of the CA-D4T, connecting cord and the AC power cord.

**CAUTION:** Make all connections before plugging the Unit into an AC power outlet.

### Connecting the AM Antenna

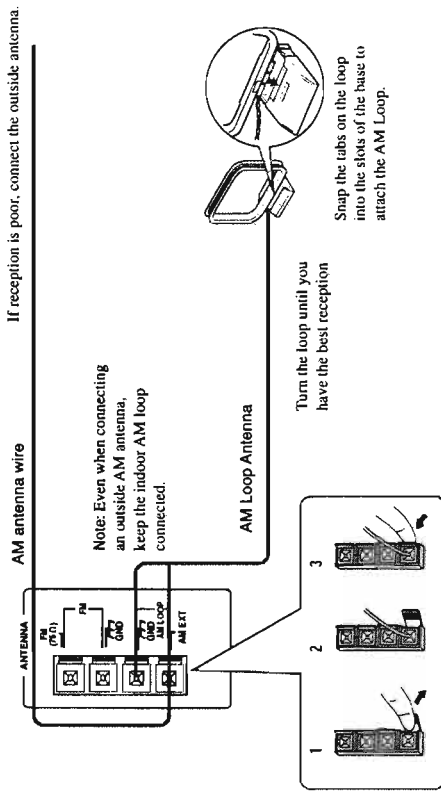

### Connecting the Speakers (Please refer to instructions for speakers as well when you connect speakers.)

- For each speaker connect one end of the speaker wire to the speaker terminals on the back of the CA-D4T and one end to the speaker.
1. Open each of the terminals and insert the speaker wires firmly, then close the terminals.
  2. Connect the red (+) and black (-) terminals of the right side speaker to the red (+) and black (-) terminals marked **RIGHT** on the CA-D4T.
  3. Connect the red (+) and black (-) terminals of the left side speaker to the red (+) and black (-) terminals marked **LEFT** on the CA-D4T.

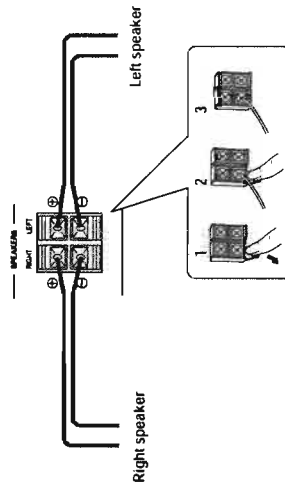

**IMPORTANT:** Use speakers with the correct impedance only. The correct impedance is indicated on the back panel.  
**CAUTION:** If a TV is installed near speakers, the TV may display irregular colors. In this case, set the speakers away from the TV.

**CAUTION:** Make all connections before plugging the Unit into an AC power outlet.

### Connecting Auxiliary Equipment

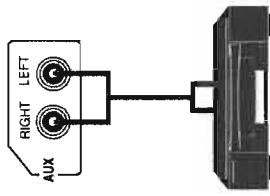

VCR or other equipment  
 To listen to these sources, press the AUX button

### Laying Out the Unit

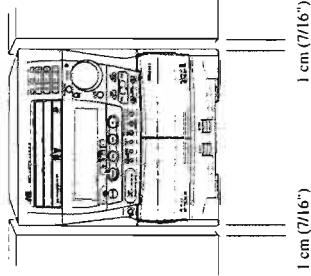

- Leave a space of at least 1 cm on both sides of the Unit and at least 10 cm at the back, for ventilation.

Now you can plug the AC power cord into the wall outlet, and your CA-D4T is at your command!

### DEMO Mode

When the CA-D4T is connected to an AC power outlet, a DEMO mode displaying some of the system's features starts.

The DEMO display cycles through the following items repeatedly:

- Scrolling display of "DEMO MODE"
- Demo of IllumiMagic COMPU PLAY buttons.
- Source Indicator.
- DISC-1 to DISC-3 Indicator.
- Demo of Live Surround effects and S.E.A effects.
- Demo of CD RANDOM PLAY.
- Demo of ACTIVE BASS EXTENSION.
- Demo of pre-setting of up to 40 FM/AM channels.

The DEMO display stops when the power is turned on.

The DEMO display will start again about one minute after the CA-D4T is set to STANDBY mode (the red STANDBY indicator is on).

### Turning the DEMO Display ON and Off

The DEMO display can be turned on and off when the system is in STANDBY mode.

To turn the DEMO display off, press the DEMO button while in DEMO mode. The display changes from the DEMO display to the clock display after "DEMO OFF" light up on the display.

To turn the DEMO display on, press the DEMO button. The display changes from the clock display to the DEMO display.



Note: The DEMO display automatically starts when the power cord is inserted into a wall outlet. To stop the DEMO display when the power cord is inserted into the wall outlet, press the DEMO button to turn the DEMO display off.

**COMPU PLAY**

COMPU PLAY is JVC's feature that lets you control the most used functions of the CA-D4T with a single touch.

What COMPU PLAY does is to automatically turn on the power and start the function you have specified. With IllumiMagic COMPU PLAY, when you approach the system to use a function, the sensor detects your action, illuminates the function buttons and displays "PRESS ANY BLINKING KEY" on the display. Not all COMPU PLAY buttons blink with the IllumiMagic COMPU PLAY function.

**IllumiMagic COMPU PLAY buttons**

The CD, FM/AM, TAPE, AUX, DISC-1, DISC-2 and DISC-3 buttons on the Uni.

**Buttons that do not blink**

On the Uni

CD Player **▲** buttons.

On the Remote Control

AUX button

TUNER button

CD player Play (**▶**) button

CD Player DISC-1 to DISC-3 buttons.

CD player Open/Close (**▲**) button

Cassette player Play (**◀** or **▶**) buttons

The functions performed when the you use the IllumiMagic COMPU PLAY buttons are explained in the relevant section for each function.

**Stopping the IllumiMagic COMPU PLAY buttons blinking and turning the guide display off**

When the system is in STANDBY mode, press the POWER button on the CA-D4T while holding down the STOP/CANCEL **■** button.

"GUIDE OFF" appears in the display.

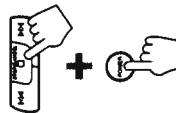

GUIDE OFF

To start IllumiMagic COMPU PLAY blinking again, repeat this operation.

"GUIDE ON" appears in the display.

GUIDE ON

**Note:** IllumiMagic COMPU PLAY buttons may interfere with the remote control operation of TV's and other remote controlled equipment. If this occurs, turn off the IllumiMagic COMPU PLAY blink function

**Using the Amplifier**

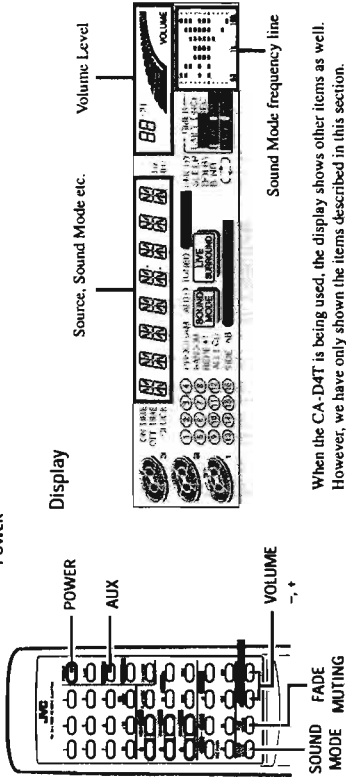
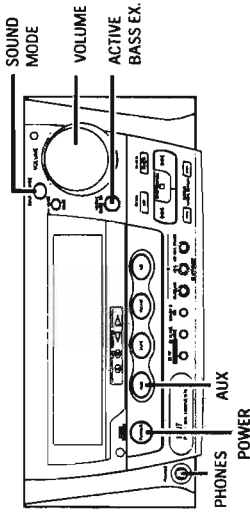

When the CA-D4T is being used, the display shows other items as well. However, we have only shown the items described in this section.

**Turning Power**

**Turning the CA-D4T On**

Press the POWER button.

The displays come on and the Standby indicator goes out.

The CA-D4T comes on ready to do whatever it was doing when the power was last shut off.

- If the last thing you were doing was listening to a tape in Deck B, you are now ready to listen to a tape again in Deck B, or you can change to another source.
- If you were listening to the Tuner last, the Tuner comes on playing the station it was last set to.

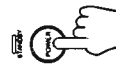

**Turning the CA-D4T Off**

Press the POWER button again.

The Standby indicator lights up and the displays blank, except for the clock display.

- Some power (16 watts) is always consumed even though power is turned off (called Standby Mode).
- To switch off the Unit completely, unplug the AC power cord from the AC outlet. When you unplug the AC power cord, the clock will reset to AM 12:00 right away, and preset Tuner stations will be erased after a few days.



**Adjusting the Volume**

Turn the VOLUME control clockwise to increase the volume or counterclockwise to decrease it. Turning the VOLUME control quickly also adjusts the volume level quickly. When use the Remote Control, press the VOLUME + button to increase the volume or press the VOLUME - button to decrease it.

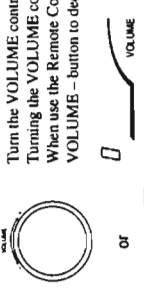

or



Display when the volume level is set to 0

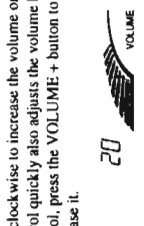

Display when the volume level is set to 20

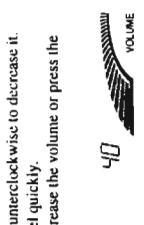

Display when the volume level is set to its maximum level

For private listening  
Connect a pair of headphones to the PHONES jack. No sound comes out of the speakers. Be sure to turn down the volume before connecting or putting headphones.

**CAUTION:** The Volume cannot be adjusted while the Unit is in **STANDBY mode**. **DO NOT** turn on the Unit and/or start playing any source without setting the VOLUME control to 0; otherwise, the sudden blast of sound can damage your hearing, speakers and/or headphones.

**FADE MUTING Function**

Set the Volume Level to 0 by pressing the FADE MUTING button on the Remote Control. Press this button again to restore the Volume Level to its previous level.



**Reinforcing the Bass Sound**

The richness and fullness of the bass sound is maintained regardless of how low you set the volume. You can use this effect only for playback.



To get the effect, press the ACTIVE BASS EX (Active Bass Extension) button. "ACT-BASS" appears in the display and the ACTIVE BASS EX indicator lights up.

ACT-BASS

To cancel the effect, press the button again. The message "OFF" appears in the display and the ACTIVE BASS EX indicator goes out.

OFF

**Sound Modes**

The CA-D4T has some preset sound effects that give you control of the way your music sounds, so you can tailor it for your room and for the quality of the source. We can give you some idea of how each one affects the music, but the only way to really tell is to try them yourself. You can use only one effect at a time, selecting from the Live Surround or S.E.A. effects is only possible for playback mode.

**Live Surround Effects**

With these effects, the sound coming from only two speakers approaches the quality of sound from four speakers.

- D. CLUB (Dance Club) Increases resonance and bass.
- HALL Adds depth and brilliance to the sound, like in a concert hall.
- STADIUM Adds clarity and spreads the sound, like in an outdoor stadium.

**Preset S.E.A. (Sound Effect Amplifier) Effects**

Adjustments of frequency range levels have been preset as three S.E.A. effects.

- ROCK Boosts low and high frequencies.
- POPS Good for vocal music.
- CLASSIC Set for wide and dynamic sound stereo systems.

To get an effect, press the SOUND MODE button repeatedly until the Sound Mode you want appears in the display.

Each time you press the button, the modes change as follows:



The display changes to display appropriate information for the Sound Mode you have selected.

When D. CLUB, HALL or STADIUM (Live Surround effects) are selected.



When ROCK, POPS or CLASSIC (S.E.A. effects) are selected.



When Sound Mode OFF is selected.

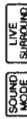

To cancel an effect, press the Sound Mode button until "OFF" appears in the display.

**Listening To Optional Equipment**

By playing the sound from auxiliary equipment through the CA-D4T, you can gain control over how the music or program sounds. Once the connected equipment is playing through the CA-D4T, you can apply the sound effects, make recordings, or listen with the headphones.

First make sure that the optional equipment is properly connected to the CA-D4T. (See page 6).



1. Set the VOLUME control to 0.

2. Press the AUX button.

The Unit automatically turns on and "AUX" lights up on the display.

AUX



3. Start playing the selected equipment.

4. Adjust the VOLUME control to the desired listening level.

5. Select a sound effect mode, if you wish.

To Cancel the Setting  
Change the source by starting any one of the CA-D4T's built-in sound sources, such as the Tuner or CD Player.



# Using the Tuner

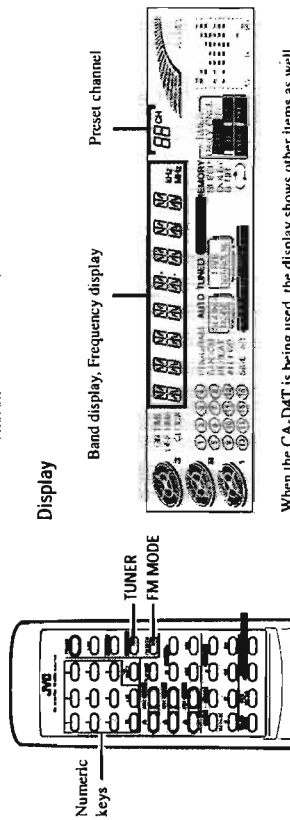
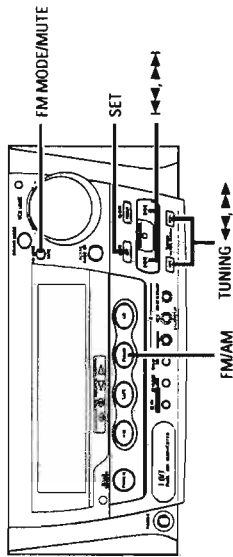

When the CA-D4T is being used, the display shows other items as well. However, we have only shown the items described in this section.

- You can listen to both FM and AM stations. Stations can be tuned in manually, automatically, or from preset memory storage.
- Before listening to the radio:
    - Check that both the FM and AM antennas are firmly connected. (See page 4 and 5).

### One Touch Radio

- Just press the FM/AM button (or the TUNER button on the Remote Control) to turn on the Unit and start playing the most recent station tuned in.
- You can switch from any other sound source to the radio by pressing the FM/AM button (or the TUNER button on the Remote Control).

### Tuning In a Station

- Press the FM/AM button (or the TUNER button on the Remote Control) to turn on the radio. The frequency of the previously selected channel appears on the display.

### Switching between Frequency Bands

- Press the FM/AM button. Each time you press the button, the band alternates between FM and AM.



### Three ways to select a station

- Press the TUNING  $\leftarrow$  or  $\rightarrow$  button on the Unit repeatedly to move from frequency to frequency until you find the one you want. (Manual Tuning).
- OR
- Hold down the TUNING  $\leftarrow$  or  $\rightarrow$  button on the Unit, the frequency starts changing on the display. When a station is tuned in, "TUNED" lights up on the display and the frequency stops changing. (Auto Tuning).
- OR
- (Possible only after presetting stations.) Press once and release the  $\leftarrow$  or  $\rightarrow$  button on the Unit to go to the next preset station, or hold the  $\leftarrow$  or  $\rightarrow$  button on the Unit to cycle through the preset stations: release the button when the preset station you want shows on the display. You can also use the Remote Control to tune in preset channels:
  - Press the TUNER button so that you can receive the most recent station tuned in.
  - Select the station by entering the preset number in the numeric keys of the Remote Control.
    - Example: for channel 5, press 5. For channel 15, press +10 then 5. For channel 20, press +10, then 10. For channel 32, press +10 three times, then 2.

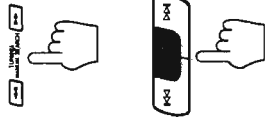

### Presetting Stations

You can store up to 40 of your favorite radio stations (FM and AM) in memory, giving you quick, easy access to the stations.

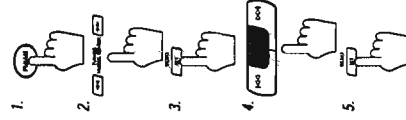

- Select a band by pressing the FM/AM button.
- Press the TUNING  $\leftarrow$  or  $\rightarrow$  button on the Unit to tune in a station.
- Press the SET button. The SET button indicator comes on, the preset number and "MEMORY" appears in the display and blinks for five seconds.
  - During these five seconds while blinking, you can assign a channel number to the station and enter it into the memory.
- Select a channel number by pressing the  $\leftarrow$  or  $\rightarrow$  button on the Unit until you find the channel number you want.
- Press the SET button and the station will be assigned to the channel number showing on the display. "MEMORY" appears in the display.

MEMORY

- If a station has been previously stored using the same channel number, this will be erased and the newly selected station will be stored.
  - If the "MEMORY" indicator goes off, start again from step 3.
- Repeat steps 1 - 5 for each station you want to store in memory with a preset number.

**CAUTION:** If the Unit is unplugged or if a power failure occurs, the preset stations will be erased in a few days. If this happens, preset the stations again.

### To Change the FM Reception Mode

When an FM stereo broadcast is hard to receive or noisy, press the FM MODE/MUTE button (or FM MODE button on the Remote Control) so that the "AUTO" indicator goes off in the display. Reception improves, but there are no stereo effects. In this monaural mode, noisy comes out while tuning in stations (since muting is also canceled).

To restore the stereo effect, press the FM MODE/MUTE button (or the FM MODE button on the Remote Control) so that the "AUTO" indicator lights up. In this stereo mode, no noise comes out while tuning in stations, and you can hear stereo sounds when a program is broadcast in stereo.



# Using the CD Player

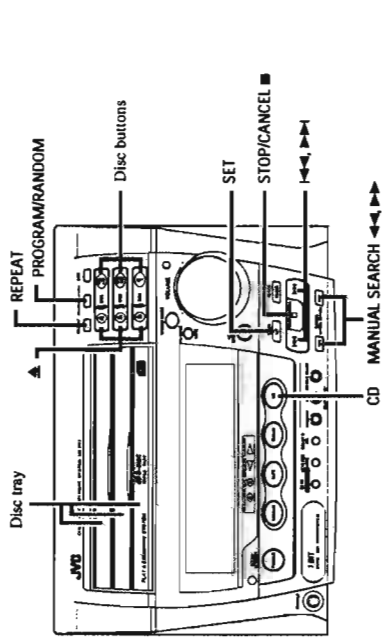

Numeric keys

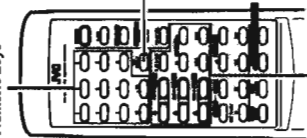

CD Player control buttons



Track number, Playing time, step number

All track numbers of the loaded CD

When the CA-D4T is being used, the display shows other items as well. However, we have only shown the items described in this section.

Disc Indicator

Each Disc button has a disc indicator. This indicator is off when the CD Player is checking that there is no disc in the disc tray for the corresponding disc number. Pressing the **▲** button turns the indicator on.

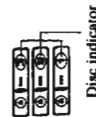

Disc indicator

Disc display

A red marker lights on the disc display for the disc number you have selected. This disc display blinks while a CD is being played.

The center of the disc display is not lit while CD Player is checking that there is no disc in the disc tray for the corresponding disc number.



Disc marker

The CA-D4T's CD Player has an Automatic Changer with 3 disc trays. You can use Continuous, Random, Program or Repeat Play for the discs in DISC-1, DISC-2 and DISC-3. Repeat Play can repeat all the tracks on all the CD's, the tracks on one of the CD's or one track on one CD. There is also the Tray Lock function, which safely keeps discs in the trays.

Here are the basic things you need to know to play a CD and locate the different selections on it. Each selection is called a track, so when we are talking about locating a track, we are also talking about how you find a certain song or performance.

## The Quickest Way To Start a CD Is With the One Touch Operation

- The power comes on, and operations are done automatically.
- Press the CD button (or the **▲** button on the Remote Control).
- If there is a CD in the disc tray of the selected (lit) disc number, playback continues from the track where it was interrupted.
- If there is no CD in any of the disc trays, the message "OPEN" appears in the display after a few seconds and the disc tray for the marked disc opens.
- Press a DISC button (1 to 3).
- If there is a CD in the disc tray for the disc number you have selected, playback begins from the first track of that disc. If there is no CD in the disc tray, the message "OPEN" appears in the display after a few seconds and the disc tray opens.
- Press the **▲** button.
- The power turns on, and the tray opens automatically.



## Basics of Using the CD Player — Continuous Play

You can play the discs continuously in the DISC 1 to DISC 3 trays.

### To Insert Discs

1. Press the **▲** button on the right of the tray you want to insert the disc into. The disc tray slides out automatically.
2. Put a CD, with its label side up, into the tray.

**ATTENTION:** To avoid malfunctions when you play a CD, please set the CD in the right place at the center of the tray.

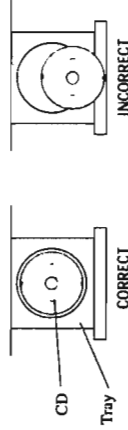

CORRECT

INCORRECT

3. Press the **▲** button to close the tray.
4. Repeat steps 1 to 3 to insert other discs into other trays.
  - To continue putting discs into other trays, even if a tray is open, by pressing the **▲** button of another disc tray, the open tray will close automatically, and the new disc tray will slide out.
- To put an 8 cm CD into a tray, insert it so that it is aligned with the groove in the tray's center.
- "OPEN" appears in the display when a tray opens, and "CLOSE" when a tray closes.

Note: When the CD Player is reading a disc, "..." appears in the display. While this is being displayed, the **▲** button or DISC button cannot be used. Once the display changes from "..." to another display, the **▲** button and DISC button can be used.

**To Play a Disc**

This function plays the disc in the Unit continuously.

1. Prepare the discs.



or

2. Press the DISC button (1-3) of the disc to play.  
The first track of the selected disc will begin playing.  
When the selected disc finishes playing, the next disc will begin playing automatically.  
When the last disc has finished playing, the Unit will stop automatically.
- When a DISC button is pressed while a tray is open, the open tray will close automatically and Continuous Play playback begins from the first track of the disc.

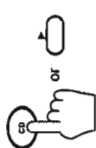

To use Continuous Play from the first track of the disc selected by the disc marker, you do not need to press a DISC button (1-3), just press the CD button (or ► button on the Remote Control).

**Playing order of discs**

- When playback starts from DISC-1, the playing order is DISC-1 → DISC-2 → DISC-3. When DISC-3 has finished, the CD Player selects DISC-1 (the disc marker is on) and stops.
- When playback starts from DISC-2, the playing order is DISC-2 → DISC-3 → DISC-1. When DISC-1 has finished, the CD Player selects DISC-2 (the disc marker is on) and stops.
- When playback starts from DISC-3, the playing order is DISC-3 → DISC-1 → DISC-2. When DISC-2 has finished, the CD Player selects DISC-3 (the disc marker is on) and stops.
- If any of the disc trays are empty, the CD Player skips that disc tray and continues through the remaining disc trays in the order shown above.

**Note:** If there is no CD in disc tray for the DISC button you pressed, the message "OPEN" appears in the display and the disc tray automatically opens.  
If there is no disc in the disc tray for the selected disc number, when the CD button (or the ► button on the Remote Control) is pressed, playback begins from the next disc.

To stop play the disc, press the ■ button (or the ■ button on the Remote Control) for the disc number being played.  
To stop play and remove the disc, press the ▲ button (or the ▲ button on the Remote Control) for the disc being played.  
To pause, press the CD button. The CD button and the Disc display will blink. (The Pause function cannot be used with the button on the Remote Control.)  
To cancel pause, press the CD button again. Play continues from the point where it was paused.

**RESUME**

When the STOP/CANCEL ■ button (or the ■ button on the Remote Control) is pressed during playback, and the source is changed, the track number is memorized even when the power is turned off. The next time the CD button (or the ► button on the Remote Control) is pressed, play resumes from the track where it was interrupted.  
To start playback from the first track, press the DISC button.

**To Change Discs While Playing**

You can replace a CD in a tray not being used, while another CD is playing.

1. Press the ▲ button of the tray not being used.  
The tray opens.
2. Replace the disc in the tray.
3. Press the ▲ button to close the tray.

**To Select a Disc, Track Or Passage Within a Track**

1. Press the DISC button (1-3) for the disc tray containing the track you want to listen to.  
Example: for the third disc, press 3.
2. Press the ◀ or ▶ button to select the track.  
The selected track starts playing.
  - Each time you briefly press and release the ◀ or ▶ button, the track changes by one.
  - Press and release the ▶ button to go ahead one track at a time.
  - Press and release the ◀ button to go back one track at a time.
  - Holding down the ◀ or ▶ button allows you to change tracks continuously.
- Holding down the MANUAL SEARCH ◀◀ or ▶▶ buttons, during playback, will fast forward/backwards the CD so you can quickly find a particular passage in the selection you are listening to. (The fast forward/backwards function cannot be used from the Remote Control.)

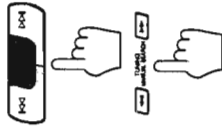

**Locating a Track With the Remote Control Directly**

Using the numeric keys on the Remote Control allows you to go directly to the beginning of any track.

1. Press the DISC button (1-3) for the disc tray containing the track you want to listen to.  
Example: for the third disc, press 3.
2. Press the CD 'KEY' button.
3. Enter the number of the track you want to listen to with the numeric keys.  
The selected track starts playing.
  - Example: for track 5, press 5. For track 15, press +10 then 5. For track 20, press +10, then 10. For track 32, press +10 three times, then 2.



**Programming the Playing Order of the Tracks**

You can change the order in which the discs and tracks play, and select only the discs and tracks you want from among those loaded in the CD Player.

By using the Remote Control, you can easily program tracks.

- You can program up to 32 steps in any desired order from among the discs in the player.
- You can only make or change a program when the CD Player is stopped.

**Using the Remote Control**



1. Press the PLAY MODE button.  
The message "PROGRAM" appears in the display and the PROGRAM indicator comes on.  
If a program is already running, the track number blinks.



- The display changes with each press of the PLAY MODE button, as shown below.  
→ PROGRAM → RANDOM → Off (Continuous Play) → (back to the beginning)



2. Select a disc with the DISC buttons (1-3). The display changes to the Program Entry display and the disc number and track number sections blink for a few seconds. The DISC buttons (1-3), SET button and or buttons on the CA-D4T also blink.

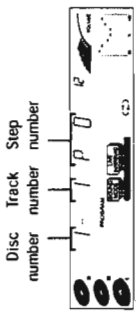

- While the display is blinking, perform the operations in steps 3 to 4. When the blinking display changes to the "PROGRAM" display, repeat the operations in steps 2 to 4.
3. Press the CD 10KEY button.
  4. Press the numeric keys (1 to 10 and +10) to select the track to program.
    - Example: for track 5, press 5. For track 15, press +10 then 5. For track 20, press +10, then 10. For track 32, press +10 three times, then 2.
 The blinking disc number and track number changes to the step number display. Also, the blinking buttons on the CA-D4T stop blinking, but remain lit.



5. Repeat steps 2 to 4 to select the other tracks for the program.
6. Press the button.
  - The Unit plays the tracks in the order you have programmed them.



Using the Unit

7. Press the PROGRAM/RANDOM button.
  - The message "PROGRAM" appears in the display and the PROGRAM indicator comes on. If a program is already running, the track number blinks.



- The display changes with each press of the PROGRAM/RANDOM button, as shown below. PROGRAM → RANDOM → Off (Continuous Play) → (back to the beginning)

2. Select a disc with the DISC buttons (1 to 3).

The display changes to the Program Entry display and the disc number and track number sections blink for a few seconds. The DISC buttons (1-3), SET button and or buttons on the CA-D4T also blink.

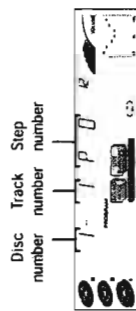

- While the display is blinking, perform the operations in steps 3 to 4. When the blinking display changes to the "PROGRAM" display, repeat the operations in steps 2 to 4.



3. Press the or buttons to select the track to program. The track number appears in the display.



4. Press the SET button.
  - The blinking disc number and track number changes to the step number display. Also, the blinking buttons on the CA-D4T stop blinking, but remain lit.



5. Repeat steps 2 to 4 to select the other tracks for the program.



6. Press the CD button.
  - The Unit plays the tracks in the order you have programmed them.

- If you try to program a 33rd track, the CA-D4T lets you know that the program is full by displaying the message "FULL" on the display.
- If you try to program an disc tray that is empty, or a track number that does not exist on a disk (for example, selecting track 14 on a disc that only has 12 tracks), the selected disc or track are skipped when the program is played.
- You can skip to a particular program step by pressing the or button during program play.
- To play the programmed tracks over and over, press the REPEAT button. "REPEAT" lights up on the display.

To stop playing, press the STOP/CANCEL button (or the button on the Remote Control) once. To modify the program, press the STOP/CANCEL button on the CA-D4T while the CD Player is stopped. With each press of the button, a track is deleted from the program until the last track is deleted.

To add tracks to the program, use the procedure above (on either the CA-D4T or the Remote Control) to add the new tracks to the program. The new tracks are added to the end of the program. To delete all the tracks in a program, keep pressing the STOP/CANCEL button on the Unit until all the tracks in the program have been deleted, or press the button for each disc in the program. To exit Program Mode, press the PROGRAM/RANDOM button (or the PLAY MODE button on the Remote Control) twice to change to Continuous Play mode.

Random Play

The tracks will play in no special order when you use this mode.



1. Press the PROGRAM/RANDOM button (or the PLAY MODE button on the Remote Control) while the CD Player is stopped to change to the RANDOM Mode display.



- The display changes with each press of the PROGRAM/RANDOM button, as show below. PROGRAM → RANDOM → Off (Continuous Play) → (back to the beginning)

2. Press the CD button (or the button on the Remote Control)
  - The tracks are played in random order.
  - When all of the tracks have been played, the CD Player stops.

Note: Press the DISC buttons (1-3), or the Numeric keys, to cancel Random play and begin playback in Continuous Play mode.

## Using the Cassette Deck (Listening to a Tape)

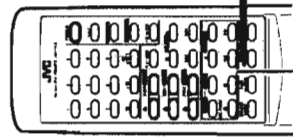
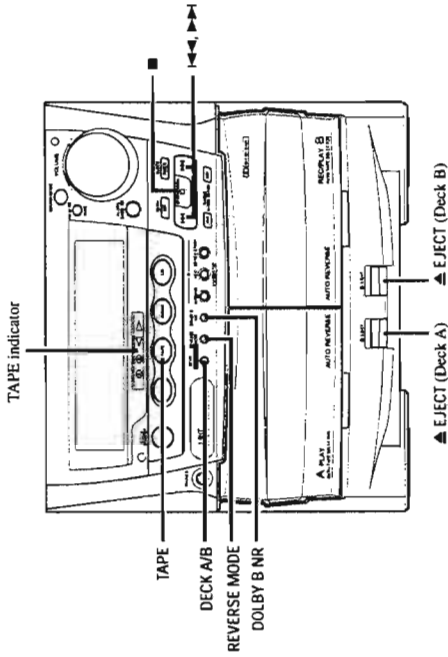

Cassette Deck control buttons

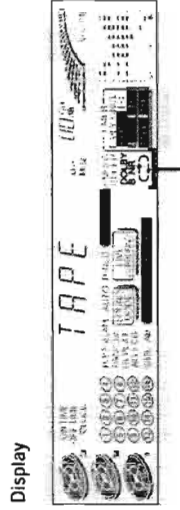

Reverse Mode Indicator

When the CA-D4T is being used, the display shows other items as well. However, we have only shown the items described in this section.

- Press the REPEAT button before or during random play to instruct the CA-D4T to continue with a different random track selection after the last selection is played.

To cancel random play, press the PROGRAM/RANDOM button (or the PLAY MODE button on the Remote Control) and select another mode.

### Repeating a Selection Or the Discs

You can have all the discs, the program or the individual selection currently playing repeat as many times as you like.



Press the REPEAT button on the CA-D4T.

The display changes with each press of the button, as shown below.  
 → REPEAT ALL → REPEAT 1 CD → REPEAT 1 → Off (Continuous Play) →  
 (back to the beginning) →

REPEAT ALL: Repeats all the tracks on the CD's in the CD Player, or all the tracks in the program.

REPEAT 1 CD: Repeats all the tracks on one CD.

REPEAT 1: Repeats one track on a CD.

- The three Repeat Modes above can be selected during Continuous Play, however, during Program Play and Random Play, you can only select REPEAT ALL or REPEAT 1.

To exit Repeat Mode, press the REPEAT button until the "REPEAT" indicator on the display goes out.

### Tray Lock Function

In order to safely keep the discs in the CD Player, the three trays can be electronically locked in a single operation.

When the electronic lock is on, the trays cannot be opened even if the ▲ button is pressed.

#### Locking the Electronic Lock

1. Put the CA-D4T's power into the STANDBY condition. If the power is on, press the POWER button to light the Standby indicator.
2. While pressing the STOP/CANCEL ■ button, press the ▲ button for DISC 1's tray on the Unit. "LOCKED" appears in the display to notify that the trays have been locked.

LOCKED

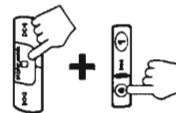

When the CD Player trays are locked, pressing the ▲ buttons displays the message: "LOCKED" on the display and the trays do not open. Also, the ▲ button cannot be used to automatically turn on the power.

#### Unlocking the Electronic Lock

1. Put the CA-D4T's power into the STANDBY condition. If the power is on, press the POWER button to light the Standby indicator.
2. While pressing the STOP/CANCEL ■ button, press the ▲ button for DISC 1's tray on the Unit. When the unlock operation is done, "UNLOCKED" appears in the display to show that the lock has been taken off.

UNLOCKED

The trays can now be opened by pressing the ▲ buttons. The ▲ button can also be used to automatically turn on the power.

The Cassette Deck allows you to play, record and dub audio tapes.

- Most tapes are now recorded with the Dolby NR system, so first check which type of the Dolby NR system has been used on the tape. Only Dolby B NR is incorporated into the CA-D4T.
- With Automatic Tape Detection, you can listen to type I or II tapes without changing any settings.

The use of tapes longer than 120 minutes is not recommended, since characteristic deterioration may occur and these tapes easily jams in the pinch-rollers and the capstans.

**Music Scan**

To find the beginning of a music track during play, use the Music Scan function. Music Scan searches for blank portions that usually separate tracks, then plays the next song.

**To Find the Beginning of the Current Song**

- Press the TAPE or button (or the or button on the Remote Control) during play.
- Make sure that you press the TAPE or button (or the or button on the Remote Control) in the opposite direction to that in which the tape is playing. Searching stops at the beginning of the current song, and the current song starts automatically.

**To Find the Beginning of the Next Song**

- Press the TAPE or button (or the or button on the Remote Control) during play.
- Make sure that you press the TAPE or button (or the or button on the Remote Control) in the same direction as that in which the tape is playing. Searching stops at the beginning of the next song, and the next song starts automatically.

Music Scan works by detecting a 4-second long blank at the beginning of each selection, so it won't work well if your tape has:

- No blank at the beginning of a track
- Noise (often caused by much use or poor quality dubbing) which fills the blank with noise.
- Long, very soft passages or pauses in a selection. The scan will detect these as 4-second long blanks. If this happens, just scan again until you reach the selection you want.

**Other Useful Features of the Cassette Deck**

- Use Reverse Mode to make the tape automatically reverse at the end of a side and start playing the other side. Press the REVERSE MODE button to change from Reverse Mode on to Reverse Mode off, or from off to on.

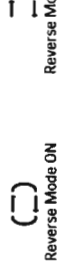

- Continuous Play: With the Reverse Mode indicator on, when tape playback in the direction finishes, the Unit always checks to see if a tape is in the other deck. If there is, it automatically starts playing. This Continuous Play function works regardless of which deck starts first.
- Press the DOLBY B NR button to switch Dolby B Noise Reduction on (the indicator lights up) or off (the indicator goes off). If a tape is recorded with the Dolby B NR system, playing it back with the Dolby NR on will reduce tape noise and improve the clarity of the sound.

Dolby noise reduction manufactured under license from Dolby Laboratories Licensing Corporation. "DOLBY" and the double-D symbol are trademarks of Dolby Laboratories Licensing Corporation.



**One Touch Play**

- Press the TAPE button. The power comes on and "TAPE" lights up on the display. When a tape is already in the tape deck, the tape is played in the direction of the blinking Tape Direction indicator. If no tape is loaded, the CA-D4T automatically turns on and wait for you to insert a tape, or select another function.

- Press the or button on the Remote Control. The power comes on and "TAPE" appears in the display. When a tape is already in the tape deck, the tape is played in the direction of the button pressed. If no tape is loaded, the CA-D4T automatically turns on and wait for you to insert a tape, or select another function.

**Regular Play**

When the power is already on, you can use this basic procedure:

- Press the EJECT button for the deck you want to use.
- When the cassette holder opens, put the cassette in, with the exposed part of the tape down, toward the base of the CA-D4T.
  - If the cassette holder does not open, turn the Unit off, then back on and press the EJECT button again.
- Close the holder gently. When both Deck A and Deck B contain a tape, the last deck to have a tape inserted is selected. To change the selected deck, press the DECK A/B button. When using the Remote Control, press the A or B button.

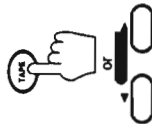

- Press the TAPE button. The tape is played in the direction of the indicator for the selected deck. To change the play direction for the tape, press the TAPE button again. When using the Remote Control, press the or button. The tape is played in the direction of the button pressed.
  - The Cassette Deck automatically stops when one side of a tape has finished playing.

To stop playing, press the button. To remove the tape, stop the tape, and press the EJECT button. To change deck while playing a tape, press the TAPE button after pressing the DECK A/B button.

When a tape is being played, pressing the TAPE button only changes the direction of playback.

**Fast Left And Fast Right**

- While the tape is stopped, press the TAPE button (or the button on the Remote Control) and the tape will wind rapidly onto the left side of the cassette without playing.
- While the tape is stopped, press the TAPE button (or the button on the Remote Control) and the tape will wind rapidly onto the right side of the cassette without playing.

The MANUAL SEARCH or buttons on the Unit can also be used for this operation.

Note: Deck A and Deck B cannot be used for playback at the same time.

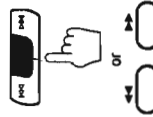

**TAPE Indicator**



The TAPE indicator tells you which direction the selected tape deck will use for playback. During playback, the direction indicator blinks slowly. During fast forward or fast reverse, the indicator blinks quickly. During Music Scan mode, the direction indicator alternates between blinking slowly and quickly repeatedly.

## Using the Cassette Deck (Recording)

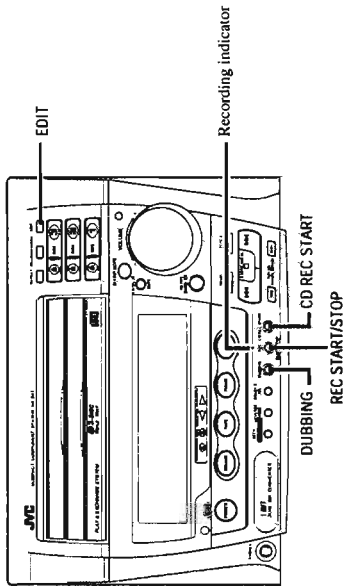

Recording onto a cassette from any of the sound sources is simple. Just place a tape in Deck B, have the source ready, make one or two settings, and you're ready to record. For each source the procedure is a little different and now we'll explain just what to do for each one. If you forget, just come back to the section which has the specific procedures you need. But first, here are a few things to make your recordings better.

### Things To Know Before You Start Recording

- It may be unlawful to record or play back copyrighted material without the consent of the copyright owner.
- Press the DOLBY B NR button — the indicator lights up — to reduce tape hiss, except when dubbing tapes, since Dolby NR is inactive in Dubbing Mode regardless of the setting of DOLBY B NR. The dubbed tape automatically contains the same processing as the source tape.
- The recording level, which is the volume at which the new tape is being made, is automatically set correctly, so it is not affected by the VOLUME control on the CA-D4T. Thus, during recording you can adjust the sound you are actually listening to without affecting the recording level.
- Two small tabs on the back of the cassette tape, one for side A and one for side B, can be removed to prevent accidental erasure or re-recording.
- To record on a cassette with the tabs removed, you must cover the holes with adhesive tape first. However, when a type II tape is used, only cover part of the hole as shown, since the other part of the hole is used to detect the tape type.
- When recording, you can hear Sound Effect effects through the speakers or headphones.
- However, the sound is recorded without Sound Mode effects.
- Type I and Type II tapes can be used for recording.



Note: At the start and end of cassette tapes, there is leader tape which cannot be recorded onto. Depending on the recording source, the first part of the recording may be missing because of the leader. When recording CDs or radio broadcasts, to get the beginning of the recording on the tape, first wind on the leader before beginning recording.

CAUTION: If recordings you have made have excessive noise or static, the Unit may be too close to a TV which was on during the recording. Either turn off the TV or increase the distance between the TV and the CA-D4T.

## Standard Recording

This is the basic method for recording any source. The CA-D4T also has special ways for recording CD to tape, and tape to tape, which save you time and effort, as well as give you some special effects.

However, when you need to add a selection to a tape you have made, or are combining selections from several sources on one tape, use the method described below, just substitute the source you want into this procedure, such as a tape in Deck A, a CD, or the Tuner. You can also record from an auxiliary source with this procedure.

### To Record Any Sound Source To Tape

Follow these steps to record from any sound source onto a tape in Deck B.

#### Using the Unit

1. Insert a blank or erasable tape into Deck B.
2. Press the REVERSE MODE button if you want to record on both sides of the tape.
  - When using Reverse Mode, insert the tape so that it will be recorded in the forwards ► direction.
3. Check the recording direction for the tape.
  - Check that the direction indicator is the same as that for the tape in the tape deck. If the directions are different, press the TAPE button twice then press the STOP ■ button.
  - When using Reverse Mode to record both sides of a tape, check that the direction indicator is in the forwards ► direction. If the direction indicator is not in the forwards ► direction, press the TAPE button twice then press the STOP ■ button.
4. Prepare the source, by, for example, tuning in a radio station, loading CDs, or turning on connected equipment.
5. Press the REC START/STOP button.
  - The Recording indicator light comes on and the CA-D4T begins recording.

#### Using the Remote Control

1. Insert a blank or erasable tape into Deck B.
2. Press the REC PAUSE button.
  - The Recording indicator light comes on.
3. Press the REVERSE MODE button if you want to record on both sides of the tape.
  - Reverse Mode comes on.
  - When using Reverse Mode, insert the tape so that it will be recorded in the forwards ► direction.
4. Prepare the source by, for example, tuning in a radio station, loading CDs, or turning on connected equipment.
5. Press the ◀ or ▶ button.
  - Recording starts in the direction of the button pressed.
  - When using Reverse Mode to record both sides of a tape, press the ▶ button.



**Notes for using Reverse Mode for recording**

When recording in Reverse Mode, the CA-D4T automatically stops when it reaches the end of the reverse ◀ direction. To record on both sides of a tape, make sure that the recording direction for the tape inserted into Deck B is forwards ▶, and that the direction indicator for the TAPE indicator is also forwards ▶, before you start recording.

**To Pause At Any Time During the Recording Process**

Press the REC PAUSE button on the Remote Control. Then press either the ◀ or ▶ button on the Remote Control or REC START/STOP button on the Unit to restart recording.

**To Stop At Any Time During the Recording Process**

Press the REC button on the CA-D4T again, or press the ■ button on the Remote Control.

**CD Direct Recording**

Everything on the CD goes onto the tape in the order it is on the CD, or according to an order you have set in a program.

1. Prepare CDs. (See page 14.)  
Check that the CD Player is stopped.

2. Insert a cassette in Deck B to record on.
  - When you want to record on both sides of a tape, press the REVERSE MODE to turn Reverse Mode on. Check that the recording direction for the tape and the TAPE indicator are correct. (See "Notes for using Reverse Mode for recording" earlier on this page.)

3. Press the CD REC START button.  
The Unit plays the CD and starts recording.



At the end of the tape, the CA-D4T automatically goes back to the beginning of the last selection and re-records it, this time gently fading out at the end. If you selected the Reverse Mode, the reverse side starts with the last selection on the front side and will be faded out at the end again. (A 10 second blank is created at the beginning of the reverse side.)

When the recording is finished, the message "CD REC FINISHED" scrolls by on the display. The CD Player and Cassette Deck stop.

**To Stop At Any Time During the Recording Process**

Press the STOP ■ button.

**Note:** When making SLEEP timer settings while doing CD Direct recording, set the time so that there is enough leeway to finish the recording before the power goes off. If the time is set to about the length of the CD, the power may go off before recording finishes.

For CD Direct Recording using more than one disc, use a blank tape. If you use a pre-recorded tape, pre-recorded sound may not be erased between newly-recorded tracks.

**Auto Edit Recording**

Using Auto Edit, you can record the CD tracks to fit the tape, so a selection isn't cut off. Auto Edit is one of the best ways to copy all of a CD onto a tape.  
Auto Edit programs the CD tracks in numerical order. To prevent the end of the last track on the front side from being cut off, the last track on the front side is selected to fit on the remaining tape length.

1. Prepare CDs. (See page 14.)
2. Press the EDIT button on the Unit.  
The DISC button (1-3) light comes on and "DISC" appears in the display.

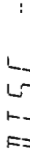

3. Press the DISC button for the disc you want to record.  
The DISC button (1-3) changes from a blinking light to a continuously lit display, and the recommended tape length for the recording appears in the display.

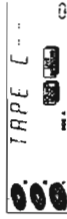

- You can select a different length of tape, depending on the actual size of the tape you are using, from eleven possibilities programmed into the CA-D4T: 40, 46, 50, 54, 60, 64, 70, 74, 80, 84, 90. Cycle through these choices using the ◀ or ▶ button until you find the length closest to your tape's actual length.

- If you pick a tape length shorter than the total playing time of the CD, the last tracks on both sides of the tape will be faded out as the tape ends.

4. Press the SET button.  
The tracks to be recorded on side B of the tape appear on the display.

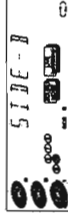

- To display the tracks that will be recorded on side A of the tape, press the SET button again. The Unit switches between Side A and Side B with each press of the SET button.
- To check the tracks that will be recorded, press the ◀ or ▶ buttons on the Remote Control.

5. Insert a cassette in Deck B to record on.  
When you want to record on both sides of a tape, press the REVERSE MODE to turn Reverse Mode on.

6. Press the CD REC START button.



The recording indicator light comes on and the CD buttons start to blink. The message "TAPE SIDE A STANDBY" scrolls by on the display and the CA-D4T prepares to start recording. If the tape has not been rewound, it is rewound to the start.

When the tape is ready, to prevent the start of a track being cut, the CA-D4T creates a blank period of 10 seconds before it starts to record the CD. (The CA-D4T also creates a 10 second blank period at the start of side B of the tape.) When recording starts, the CD button changes from a blinking light to a continuously lit display.

When the recording is finished, the message "CD REC FINISHED" scrolls by on the display. The CD Player and Cassette Deck stop.



## Using the Timers

To stop at any time while recording, press the STOP button. The CD Player stops, and then the Cassette Deck stops about four seconds later.

To cancel Auto Edit, press the button for disc number being recorded, or press the PROGRAM/RANDOM button while the CD Player is stopped.

Note: When making SLEEP timer settings while doing Auto Edit recording, set the time so that there is enough leeway to finish the recording before the power goes off. If the time is set to about the length of the CD, the power may go off before recording finishes.

### Tape To Tape Recording (Dubbing)

Recording from one tape to another is called dubbing.

- You can dub tapes simply, with just a single button.
- When dubbing tapes, make sure that the playback direction of Deck A and Deck B are the same.
- When you want to record both sides of a tape, press the REVERSE MODE to turn Reverse Mode on. Make sure that the play direction for the tapes in both Deck A and Deck B are in the forwards direction, and that the TAPE indicator is also in the forwards direction before you start recording.
- It is preferable that the type of tape (Type I or Type II) you record from be the same as the type you record onto.

#### How To Use the DUBBING Button

1. Insert the source cassette you want to copy from into Deck A for playback.
2. Insert the blank or erasable cassette you want to copy onto in to Deck B for recording.



3. Press the DUBBING button.

- Deck A and Deck B will start simultaneously.
- If the tape has not been rewound, it is rewound before dubbing starts.

To stop dubbing, press the STOP button (or button on the Remote Control).

- Dolby NR is inactive in dubbing mode regardless of the setting of DOLBY B NR. The dubbed tape automatically contains the same processing as the source tape.
- When doing dubbing with the DUBBING button, you can hear Sound Mode effects through the speakers or headphones. However, the sound is dubbed without Sound Mode effects.

### Recording With the Timer

The Cassette Deck can be set to record a tape automatically. This is especially useful for recording broadcasts when you are not at home, or late at night when you are asleep.

1. Insert a cassette for recording into Deck B.
2. Set the ONCE REC Timer, by following the steps in "Setting the ONCE REC (Recording) Timer" (Page 31).

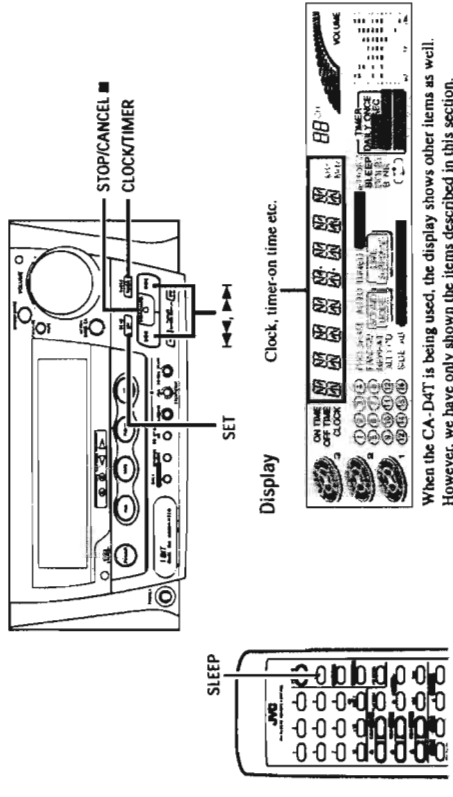

When the CA-D4T is being used, the display shows other items as well. However, we have only shown the items described in this section.

The timers lets you control recording and listening functions automatically.

- Three types of timers are available:
- DAILY Timer — Wake up to music from any source.
  - ONCE REC (Recording) Timer — Unattended recording of radio broadcasts. You can set the starting time and length of the recording.
  - SLEEP Timer — Fall asleep and have your CA-D4T turn off automatically after a certain length of time.

### Clock Setting

The timers depend on the clock: the clock must be right for the timers to work as you expect. Note that the clock must be set, or the timers cannot be set.

#### Setting the Clock

1. Press the CLOCK/TIMER button.  
The SET button light comes on.
2. Set the hour by pressing the left or right button.  
Pressing the left button increase the hour, and pressing the right button decrease it. Holding down these buttons allows you to continuously adjust the hour setting until the button is released.
3. Press the SET button.  
Check that the hour setting is correct.
4. Set the minutes by pressing the left or right button.  
Pressing the left button increase the minute, and pressing the right button decrease it. Holding down these buttons allows you to continuously adjust the minute setting in 10 minute increments until the button is released.
5. Press the SET button.  
The SET button light goes out and the clock is set to the hour and minute you have selected starting from zero seconds after "CLOCK OK" appears in the display.



**CAUTION:** If there is a power failure, the clock loses its setting. The display shows "AMT2:00", and the clock must be reset.

### Setting the DAILY Timer

With this timer you can wake up to music from a CD, tape or your favourite radio program.  
 You can set the DAILY Timer whether the Unit is on or off.

#### Procedure For Setting the DAILY Timer

The DAILY Timer is used to set the various settings, from the Timer ON setting to the Volume level. Use the or buttons to select each setting then press the SET button to complete the setting. To correct any errors in the setting, press the STOP/CANCEL button, and go back through the settings until you reach the Timer ON setting. The , , SET and STOP/CANCEL buttons blink if they can be used in a particular setting. When the SET button is pressed, the settings for the next item are displayed on the display.

- Press the TIMER button and so that "DAILY Timer" appears in the display.  
 The message "DAILY" blinks on the display, and the DAILY indicator light blinks.

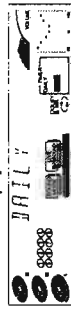

- The display changes with each press of the button, as shown below.  
 DAILY (blinks) → ON TIME (blinks) → ONCE REC (blinks) → ON TIME (blinks) → CLOCK (blinks) (Clock setting mode) → original display before the TIMER button was pressed → to the beginning

- Press the TIMER button again.  
 The display changes to the blinking "DAILY" or a blinking display of the Timer ON setting.



- Set the time you want the Unit to turn on.

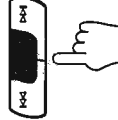

The "OFF TIME" hour setting starts to blink after the "ON TIME" minute setting is set.

- Set the time you want the Unit to turn off.

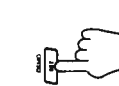

- Select the source you want to listen to.

When CD is selected,



When TAPE, FM or AM are selected,



CD: Select this when you want to listen to a CD. When CD is selected, you can set the disc number and track number (1-20).  
 Use the procedure below to set the disc number and track number.

- Set the disc number.



- If a disc number is not set, the disc indicated by the disc marker is selected.

- Set the track number.



- If no track number is set, playback starts from the first track.

TAPE: Select this when you want to listen to a cassette tape.

FM: Select this when you want to listen to a FM channel.

AM: Select this when you want to listen to an AM channel.

- If you select FM or AM as the source, the last played station is the one which comes on at the set time.

- Setting the Volume Level.

When the volume level is set, the message "TIMER OK" is displayed, and the blinking "DAILY" indicator changes to a continuously lit display to let you know that the DAILY Timer setting is complete.



- Turn the power off.

When the timer start time arrives, the CA-D4T's power is turned on and the source you selected is played. When the timer end time comes, the power is turned off again.

- If you press any source button while the DAILY Timer is active, the timer operation is cancelled.



#### Before Turning Off the Unit

- If the source is a CD, make sure that there is a CD in the selected disc number.
- If the source is a tape:
  - Check that the tape direction is correct. This is important especially when Reverse Mode is off.
  - Deck B has priority, so if tapes are in both decks, the tape in Deck B plays first.
- Set Reverse Mode on if you want to play both sides of the tape.
- Select the Sound Mode if you want to listen using a Sound Mode (D, CLUB, HALL, STADIUM, etc.).

To change the DAILY Timer setting

To change the settings for the DAILY Timer, repeat the setting procedure from the beginning.

#### Turning the DAILY Timer On and Off

Once the DAILY Timer has been set it will be activated at the same time every day until the setting is turned off.

To turn the DAILY Timer off, press the TIMER button until "DAILY" appears in the display, then press the STOP/CANCEL button.  
 The message "OFF" appears in the display.

To turn the DAILY TIMER on again, press the TIMER button until "DAILY" appears in the display, then press the SET button.  
 The Timer ON TIME, OFF TIME, PLAYBACK SOURCE (including the disc number and track number if a CD source is selected) are displayed on the display.

**CAUTION:** If the CA-DAT is unplugged, or a power failure occurs, the timer setting will be erased after 2 or 3 days. If the settings are erased in this way, reset the timer settings.

### Setting the ONCE REC (Recording) Timer

With the Recording Timer you can make a tape of a radio broadcast automatically whether or not you are home. For the timer to work correctly, you need to make sure of the following in addition to setting the time for the Tuner and Cassette Deck to come on:

- You can set the Recording Timer whether the Unit is on or off.
- The tape you want to record onto must be in Deck B.
- The radio station whose program you want to tape must be the last one played before the timer comes on.

#### Procedure for Setting the Recording Time

1. Press the **TIMER** button until "ONCE REC" appears in the display. The message "ONCE REC" blinks on the display and the ONCE REC indicator light blinks.



- The display changes with each press of the button, as shown below.  
DAILY (blinks) → ON TIME (blinks) → ONCE REC (blinks) → ON TIME (blinks) → CLOCK (blinks) (Clock setting mode) → original display before the **TIMER** button was pressed → to the beginning)

2. Press the **TIMER** button again.



The display changes from "ONCE REC" to the setting display for the **TIMER ON** time.



3. Set the time you want the radio to come on, and put a tape in Deck B to record on.
  - Use the **←** or **→** button to set the start time, then press the **SET** button.
4. Set the time you want the radio to shut off and the tape in Deck B to stop recording.
  - Use the **←** or **→** button to set the off time, then press the **SET** button.
  - The message "TIMER OK" is displayed, and the blinking "ONCE REC" indicator changes to a continuously lit display to let you know that the ONCE REC Timer setting is complete.
5. Turn the power off.
  - When the set time comes, the CA-D4T turns the power on and records the broadcasting station you selected last, before turning the power off.
  - If a button is pressed when the Recording timer is operating, recording continues but the timer is cancelled.



#### Before the Timer Starts

- Check that the recording direction for the tape and the TAPE indicator are the same.
- Set Reverse Mode to on if you want to record on both sides of the tape. Check that the recording direction and the direction of the TAPE indicator are correct. (See "Notes for using Reverse Mode for recording" on page 25)
- The **VOLUME** control is automatically set to 0 when ONCE REC Timer is recording.

It is very easy, and can be very disappointing, to forget to put in a tape, or to accidentally leave a tape in Deck B you don't want recorded over. Although this happens to almost everyone at one time or another, we hope it won't happen to you!

#### To Change the Recording Timer Setting

To change the settings for the ONCE REC Timer, repeat the setting procedure from the beginning.

### Turning the ONCE REC Timer On and Off

Once the ONCE REC Timer has been used to record a source, the setting is maintained but the Timer is set to OFF.

To record at the same time again, press the **TIMER** button, select the "ONCE REC" display and press the **SET** button to turn the ONCE REC Timer on. The **ON TIME** and **OFF TIME** are displayed.

To turn the ONCE REC Timer off before the timer starts, press the **TIMER** button, select the "ONCE REC" display and press the **STOP/CANCEL** button to turn the timer off. The message "OFF" appears in the display.

**CAUTION:** If the CA-DAT is unplugged, or a power failure occurs, the timer setting will be erased after 2 or 3 days. If settings are erased in this way, reset the timer settings.

### Setting the SLEEP Timer

Use the Sleep Timer to turn the Unit off after a certain number of minutes when it is playing. By setting this timer, you can fall asleep to music and know your Unit will turn off by itself rather than play all night.

- You can only set the Sleep Timer when the Unit is on and a source is playing.

To set the SLEEP Timer, follow this procedure:

1. With the CA-DAT on and a source playing, press the **SLEEP** button on the Remote Control. The message "SLEEP" appears in the display.

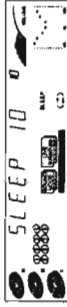

2. Set the length of time you want the source to play before shutting off.
  - Each time you press this button while the "SLEEP" indicator is blinking, it changes the number of minutes shown on the display in this sequence:

→ 10 → 20 → 30 → 60 → 90 → 120 → Cancelled → (back to the beginning)

When the number of minutes you want shows on the display, just wait 5 seconds until the indicator stops blinking, and is lit steadily.

The Unit is now set to turn off after the number of minutes you set.

#### To Change the SLEEP Timer Setting

Press the **SLEEP** button until the number of minutes you want appears on the display.

#### To Cancel the SLEEP Timer Setting

Press the **SLEEP** button until the "SLEEP" indicator goes off on the display.

Turning off the Unit also cancels the SLEEP Timer.

# Troubleshooting

- If you are having a problem with your CA-D4T, check this list for a possible solution before calling for service.
- If you cannot solve the problem from the hints given here, or the Unit has been physically damaged, call a qualified person, such as your dealer, for service.

Symptom	Possible Cause	Action
No sound is heard.	Connections are incorrect, or loose.	Check all connections and make corrections. (See pages 4 - 6.)
Unable to record.	Cassette record protect tabs are removed.	Cover holes on back edge of cassette with tape.
Poor radio reception	<ul style="list-style-type: none"> <li>• The antenna is disconnected.</li> <li>• The AM Loop Antenna is too close to the Unit.</li> <li>• The FM Wire Antenna is not properly extended and positioned.</li> </ul>	<ul style="list-style-type: none"> <li>• Re-connect the antenna securely.</li> <li>• Change the position and direction of the AM Loop Antenna.</li> <li>• Extend FM Wire Antenna to the best reception position.</li> </ul>
The CD skips.	The CD is dirty or scratched.	Clean or replace the CD.
Unable to operate the Remote Control.	<ul style="list-style-type: none"> <li>• The path between the Remote Control and the sensor on the Unit is blocked.</li> <li>• The batteries have lost their charge.</li> </ul>	<ul style="list-style-type: none"> <li>• Remove the obstruction.</li> <li>• Replace the batteries.</li> </ul>
The CD tray cannot be opened.	The main AC power cord is not plugged in.	Plug in the AC power plug.
The CD does not play.	The CD is upside down.	Put the CD in with the label side up.
Operations are disabled.	The built-in microprocessor has malfunctioned due to external electrical interference.	Unplug the Unit then plug it back in.
The cassette door cannot be opened.	During tape playing, the power cord was unplugged.	Plug in the power cord, press the POWER button, and then the EJECT button.

## Timer Priority

- Since each timer can be set independently, you may wonder what happens if the settings overlap. Here are the priorities for each timer:
- The ONCE REC Timer always has priority. This means that:
    - If another timer is set to come on during a time when the ONCE REC Timer is operating, the other timer just won't come on at all, so you will always get the entire program on tape.
    - If the ONCE REC Timer is set to come on while another timer is operating, the other timer will shut off 10 seconds before the ONCE REC Timer is set to turn on, and the ONCE REC Timer will then take over.
  - The SLEEP Timer has priority over the DAILY Timer. This is important because if you set the SLEEP Timer to start before and then end after the DAILY Timer would start, the DAILY Timer doesn't come on. So if you want your alarm to go off as scheduled, be sure the SLEEP Timer shuts off before the DAILY Timer is set to turn on the Unit.

Example 1

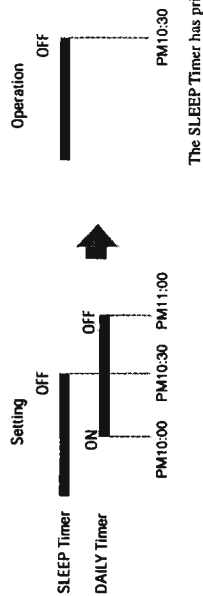

Example 2

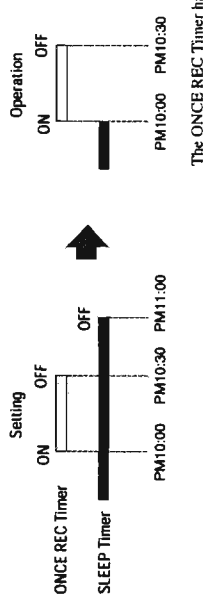

Example 3

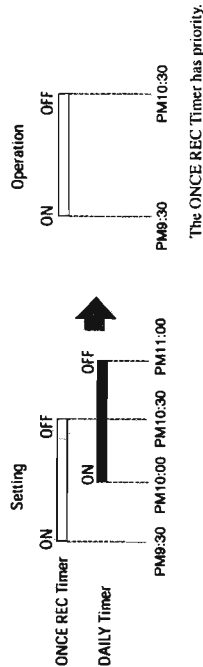

## Description of the ICs

### ■ MN172412J6N( IC701) : System Controller

#### 1. Terminal layout

42	~	22
43		21
}		}
63		1
64	~	84

#### 2. Key matrix

	KEY IN 0 (49pin)	KEY IN 1 (50pin)	KEY IN2 (51pin)		KEY IN 0 (49pin)	KEY IN 1 (50pin)	KEY IN2 (51pin)
1G (3pin)	PROGRAM/ (S701)	EDIT (S702)	REPEAT RANDOM (S703)	6G (8pin)	CD (S716)	REC (S717)	◀◀ (S718)
2G (4pin)	OPEN / CLOSE 1 (S704)	OPEN / CLOSE 2 (S705)	OPEN / CLOSE 3 (S706)	7G (9pin)	FM / AM (S719)	DUBBING (S720)	STOP / CLEAR (S721)
3G (5pin)	DISC 1 (S707)	DISC 2 (S708)	DISC 3 (S709)	8G (10pin)	TAPE (S722)	DOLBY B NR (S723)	▶▶ (S724)
4G (6pin)	KARAOKE (S710)	SOUND MODE (S711)	BASS (S712)	9G (11pin)	AUX (S725)	REVERSE MODE (S726)	▶▶ (S727)
5G (7pin)	DEMO / SET (S713)	CD REC START (S714)	◀◀ (S715)	10G (12pin)	POWER (S728)	A/B (S729)	CLOCK TIMER (S730)

#### 3. Terminal Function

Pin No.	Symbol	I/O	Functions and Operations	Pin No.	Symbol	I/O	Functions and Operations
1	S11	O	FL Segment control output	45	COMCLK	I	Clock signal input from IC751
2	S12	O	FL Segment control output	46	COMDT1	I	Data signal input from IC751
3	1G	O	FL Grid control output(Key matrix output)	47	COMDT2	O	Data signal output for IC751
4	2G	O	FL Grid control output(Key matrix output)	48	RMIN	I	Remote control signal input
5	3G	O	FL Grid control output(Key matrix output)	49	KI0	I	Key matrix input
6	4G	O	FL Grid control output(Key matrix output)	50	KI1	I	Key matrix input
7	5G	O	FL Grid control output(Key matrix output)	51	KI2	I	Key matrix input
8	6G	O	FL Grid control output(Key matrix output)	52	COMRDY	I	Redy signal input from IC851
9	7G	O	FL Grid control output(Key matrix output)	53	PRT	I	Protector signal input
10	8G	O	FL Grid control output(Key matrix output)	54	JOG IN 1	I	Input 1 of JOG Pulse
11	9G	O	FL Grid control output	55	JOG IN 2	I	Input 2 of JOG Pulse
12	10G	O	FL Grid control output	56	IFDATA	I	Data signal input from IC121
13	11G	O	FL Grid control output	57	TCLK	O	Clock signal output for IC121
14	12G	O	FL Grid control output	58	TDATA	O	Data signal output for IC121
15	13G	O	FL Grid control output	59	TCE	O	Thip enable for IC121
16	14G	O	FL Grid control output	60	/INH	I	Inhibit signal input
19	S13	O	FL Segment control output	61	SPK	O	Speaker relay control signal output
20	S14	O	FL Segment control output	62	SCL	O	Clock signal output for IC401
21	S15	O	FL Segment control output	63	SDA	O	Data signal output for IC401
22	S16	O	FL Segment control output	64	CD,IND	O	'CD' indicator control signal
23	V <sub>pp</sub>	—	Power supply(-V <sub>pp</sub> ,...)	65	TUNER,IND	O	'TUNER' indicator control signal
24	S17	O	FL Segment control output	66	TAPE,IND	O	'TAPE' indicator control signal
25	S18	O	FL Segment control output	67	AUX,IND	O	'AUX' indicator control signal
26	S19	O	FL Segment control output	68	RESET	I	System reset signal signal input
30	STOP,IND	O	'STOP' indicator control signal	69	X1	—	Connection of the GND
31	SET,IND	O	'SET' indicator control signal	71	VSS	—	Connection of the GND
32	DISC1,IND	O	'DISC1' indicator control signal	72	OSC2	—	Oscillation terminal (6MHz)
33	DISC2,IND	O	'DISC2' indicator control signal	73	OSC1	—	Oscillation terminal (6MHz)
34	DISC3,IND	O	'DISC3' indicator control signal	74	V <sub>DD</sub>	—	Power supply(+ 5V)
35	SKIP,IND	O	'SKIP' indicator control signal	75	S1	O	FL Segment control output
36	SURROUND	O	SURROUND control signal output	76	S2	O	FL Segment control output
37	V,MASK	O	Vocal masking control signal output	77	S3	O	FL Segment control output
38	ECHO1	O	Echo1 control signal output	78	S4	O	FL Segment control output
39	ECHO2	O	Echo2 control signal output	79	S5	O	FL Segment control output
40	T,MUTE	O	Tuner mute signal output	80	S6	O	FL Segment control output
41	S,MUTE	O	Sourse mute signal output	81	S7	O	FL Segment control output
42	POWER	O	Power control signal output	82	S8	O	FL Segment control output
43	H,PH,IN	I	Head phone detect signal input	83	S9	O	FL Segment control output
44	RMOUT	O	Infrared ray LED output for IllumiMagic compu play	84	S10	O	FL Segment control output

# CA-D4T

## ■ MN172412K8D (IC751) : Deck & CD Controller

### 1. Terminal layout

42 ~ 22	
43	21
}	}
63	1
64 ~ 84	

### 3. Pin Functions

Pin No.	Symbol	I/O	Function	Pin No.	Symbol	I/O	Function
1	APACK	I	APACK switch detect input	43	COMDT2	O	Data 2 signal for IC701
2	AEQ	O	Play equalizer control	44	NC	--	Pull down
3	DECKAI	O	Indication control	45	SQCK	O	Clock signal for sub code and Q register
4	DECKBI	O	Indication control	46	SUBQ	I	Sub code and Q register signal input
5	PLAYRI	O	Indication control	47	LSI POWER	O	CD LSI Power output control
6	PLAYFI	O	Indication control	48	STAT	I	Status signal input
7	RECI	O	Indication control	49	/RST	O	System reset signal output
8	STDBY	O	Indication control	50	NC	--	Non connection
9	NC	--	Non connection	51	NC	--	Non connection
10	NC	--	Non connection	52	/RESET SW	I	CD mech. rest switch input
11	NC	--	Non connection	53	MLD	O	μ-com comand road signal output
12	PBEQ	O	Play equalizer select output	54	MDATA	O	μ-com comand data signal output
13	MSIN	I	Music scan signal input	55	MCLK	O	μ-com comand clock signal output
14	NR	O	Dolby ON/OFF control	56	DATA	O	Data signal output for changer μ-com
15	CAPN	O	Capstan (ON/OFF) control	57	SCK	O	Clock signal output for changer μ-com
16	BPLZ	O	B mech. pranger control output	58	CHST	O	Strove signal output for changer μ-com
17	APLZ	O	A mech. pranger control output	59	REQI	I	Redy signal input from changer μ-com
18	FADE	O	FADE mode control	60	NC	--	Non connection
19	AMT	O	It is "H" when Deck A is not playing	61	NC	--	Non connection
20	BMT	O	It is "H" when Deck B is not playing	62	NC	--	Non connection
21	OMT	O	Deck P.B mute control signal	63	GND	--	GND
22	RMT	O	Rec. P.B select signal output	64	NC	--	Non connection
23	GND	--	GND	65	NC	--	Non connection
24	PB/REC	O	It is "H" when NR recording	66	NC	--	Non connection
25	REC	O	It is "H" when recording	67	NC	--	Non connection
26	BIAS	O	REC bias ON/OFF control	68	RESET	I	System reset signal input
27	NC	--	Non connection	69	GND	--	GND
28	NC	--	Non connection	70	NC	--	Non connection
29	NC	--	Non connection	71	GND	--	GND
30	NC	--	Non connection	72	OSC	--	Oscillation terminal(6MHz)
31	NC	--	Non connection	73	OSC	--	Oscillation terminal(6MHz)
32	GND	--	Connection to the ground	74	VDD	--	Power supply
33	GND	--	Connection to the ground	75	DCS OUT	O	DCS signal output
34	GND	--	Connection to the ground	76	DCS IN	I	DCS signal input
35	GND	--	Connection to the ground	77	APLS	I	A mech. reel pulse input
36	GND	--	Connection to the ground	78	PSWA	O	A mech. play switch output
37	GND	--	Connection to the ground	79	BEQ	O	Bias current and Playing EQ control
38	GND	--	Connection to the ground	80	PSWB	I	B mech. play switch output
39	GND	--	Connection to the ground	81	PBLS	I	B mech. reel pulse input
40	COMRDY	O	Redy signal output to IC701	82	FREC	I	FREC switch detect input
41	COMCLK	O	Clock signal for IC701	83	RREC	I	RREC switch detect input
42	COMDT1	I	Data 1 signal from IC701	84	BPACK	I	BPACK switch detect input

■ UPD65612GB-165(IC801) : Changer Controller

1. Terminal Layout

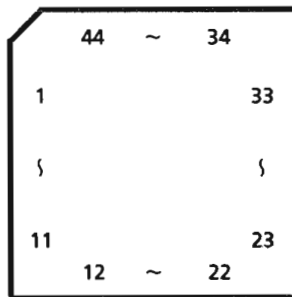

2. Pin Functions

Pin No.	Symbol	I/O	Function	Pin No.	Symbol	I/O	Function
1	NC	--	Non connection	23	2SSW	I	TRAY2 switch input signal
2	NC	--	Non connection	24	1SSW	I	TRAY1 switch input signal
3	NC	--	Non connection	25	NC	--	Non connection
4	OS1I	I	Oscillation terminal	26	CAM0	I	Cam switch input signal for LCAM
5	OS1O	O	Oscillation terminal	27	CAM1	I	Cam switch input signal for LCAM
6	OS2I	I	Oscillation terminal	28	CAM2	I	Cam switch input signal for LCAM
7	OS2O	O	Oscillation terminal	29	CAM3	I	Cam switch input signal for LCAM
8	NC	--	Non connection	30	CAM4	I	Cam switch input signal for RCAM
9	C25IN	I	Connected to C25OUT	31	CAM5	I	Cam switch input signal for RCAM
10	C25OUT	O	Connected to C25IN	32	CAM6	I	Cam switch input signal for RCAM
11	RESET	I	Reset signal input	33	CAM7	I	Cam switch input signal for RCAM
12	REQ	O	Output the "mecha. data request"	34	FIT	O	Connected to C50
13	DATA	I/O	Control,Status data I/O	35	C50	I	Connected to FIT
14	ST	I	Strobe signal input	36	LMUP	O	L motor control signal
15	CKS	I	Clock input	37	LMDWN	O	L motor control signal
16	SELECT	--	Connected to GND	38	C25	--	Non connection
17	GND	--	GND	39	VDD	--	Power supply terminal
18	CK	--	Connected to GND	40	C100	--	Non connection
19	1MSW	I	TRAY1 switch input signal	41	RMUP	O	R motor control signal
20	2MSW	I	TRAY2 switch input signal	42	RMDWN	O	R motor control signal
21	3MSW	I	TRAY3 switch input signal	43	NC	--	Non connection
22	3SSW	I	TRAY3 switch input signal	44	NC	--	Non connection

# CA-D4T

## ■ MN35510 (IC603) : DIGITAL SERVO & DIGITAL SIGNAL PROCESSER

### 1. Terminal Layout

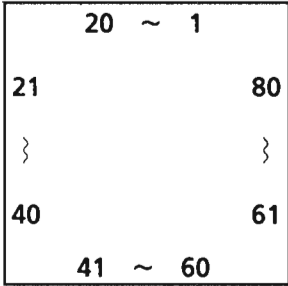

### 2. Block Diagram

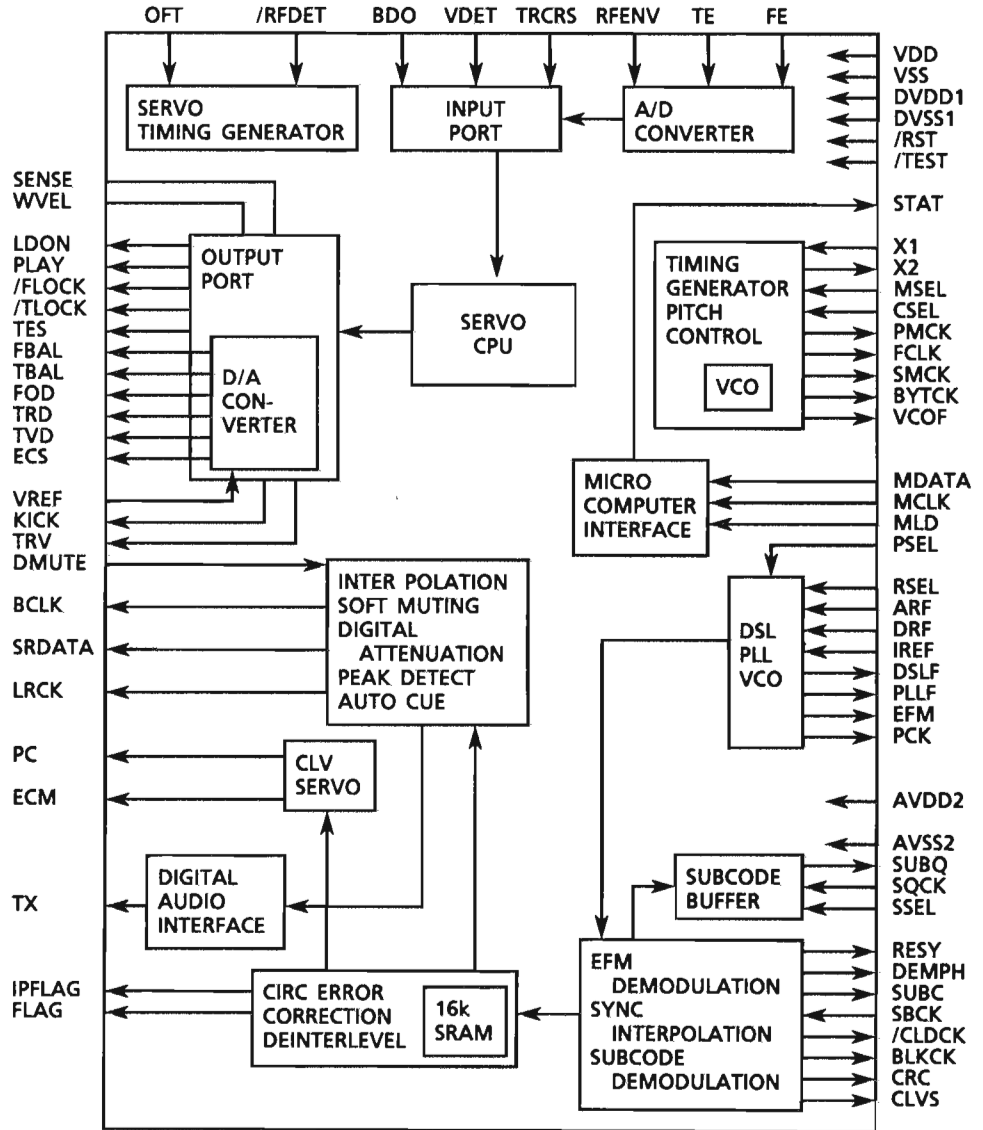



## 3. Description

Pin No.	symbol	I/O	Description	Pin No.	symbol	I/O	Description
1	BCLK	O	Not used	41	TES	O	Tracking error shunt signal output (H;shunt)
2	LRCK	O	Not used	42	PLAY	—	Not used
3	SRDATA	O	Not used	43	WVEL	—	Not used
4	DVDD1	—	Power supply(Digital)	44	ARF	I	RF signal input
5	DVSS1	—	Not used	45	IREF	I	Reference current input pin
6	TX	O	Not used	46	DRF	I	Bias pin for DSL
7	MCLK	I	$\mu$ -com command clock signal input (Data is latched at signal's rising point)	47	DSLIF	I/O	Loop filter pin for DSL
8	MDATA	I	$\mu$ -com command data input	48	PLLIF	I/O	Loop filter pin for PLL
9	MLD	I	$\mu$ -com command load signal input	49	VCOF	—	Not used
10	SENSE	O	Not used	50	AVDD2	—	Power supply (Analog)
11	FLOCK	O	Not used	51	AVSS2	—	Connected to GND(Analog)
12	TLOCK	O	Not used	52	EFM	—	Not used
13	BLKCK	O	Subcode · block · clock signal output	53	PCK	—	Not used
14	SQCK	I	Outside lock for sub-code Q resistor input	54	PDO	—	Not used
15	SUBQ	O	Sub-code Q-code output	55	SUBC	—	Not used
16	DMUTE	—	Connected to GND	56	SBCK	—	Not used
17	STATUS	O	Status signal (CRC,CUE,CLVS,TTSTOP,ECLV,SQOK)	57	VSS	—	Connected to GND(for X'tal oscillation circuit)
18	RST	I	Reset signal input (L :Reset)	58	X1	I	Input of 16.9344MHz X'tal oscillation circuit
19	SMCK	—	Not used	59	X2	O	Output of X'tal oscillation circuit
20	PMCK	—	Not used	60	VDD	—	Power supply(for X'tal oscillation circuit)
21	TRV	O	Traverse enforced output	61	BYTCK	—	Not used
22	TVD	O	Traverse drive output	62	CLDCK	—	Not used
23	PC	—	Not used	63	FCLK	—	Not used
24	ECM	O	Spindle motor drive signal (Enforced mode output) 3-State	64	IPPLAG	—	Not used
25	ECS	O	Spindle motor drive signal (Servo error signal output)	65	FLAG	—	Not used
26	KICK	O	Kick pulse output	66	CLVS	—	Not used
27	TRD	O	Tracking drive output	67	CRC	—	Not used
28	FOD	O	Focus drive output	68	DEMPH	—	Not used
29	VREF	I	Reference voltage input pin for D/A output block(TVD,FOD,FBAL,TBAL)	69	RESY	—	Not used
30	FBAL	O	Focus Balance adjust signal output	70	IOSEL	—	Pull up
31	TBAL	O	Tracking Balance adjust signal output	71	TEST	—	Pull up
32	FE	I	Focus error signal input(Analog input)	72	AVDD1	—	Power supply (Digital)
33	TE	I	Tracking error signal input(Analog input)	73	OUT L	O	Lch audio output
34	RF ENV	I	RF envelope signal input(Analog input)	74	AVSS1	—	Connected to GND
35	VDET	I	Vibration detect signal input(H : detect)	75	OUT R	O	Rch audio output
36	OFT	I	Off track signal input(H : off track)	76	RSEL	—	Pull up
37	TRCRS	I	Track cross signal input	77	CSEL	—	Connected to GND
38	RFDET	I	RF detect signal input (L : detect)	78	PSEL	—	Connected to GND
39	BDO	I	BDO input pin (H : drop out)	79	MSEL	—	Connected to GND
40	LDON	O	Laser ON signal output (H : on)	80	SSEL	—	Not used

# CA-D4T

## ■ AN8806SB (IC601) : RF & SERVO AMP

### 1. Terminal Layout

PD	1	36 PDAC
LD	2	35 PD8D
LDON	3	34 PDE
LDP	4	33 PDF
VCC	5	32 PDER
RF-	6	31 PDFR
RF OUT	7	30 TBAL
RF IN	8	29 FBAL
C.AGC	9	28 FE-
ARF	10	27 FE OUT
C.ENV	11	26 TE-
C.EA	12	25 TE OUT
CS BDO	13	24 CROSS
BDO	14	23 TE BPF
CS BRT	15	22 VDET
OFTR	16	21 LD OFF
/NRFDET	17	20 VREF
GND	18	19 ENV

### 2. Block Diagram

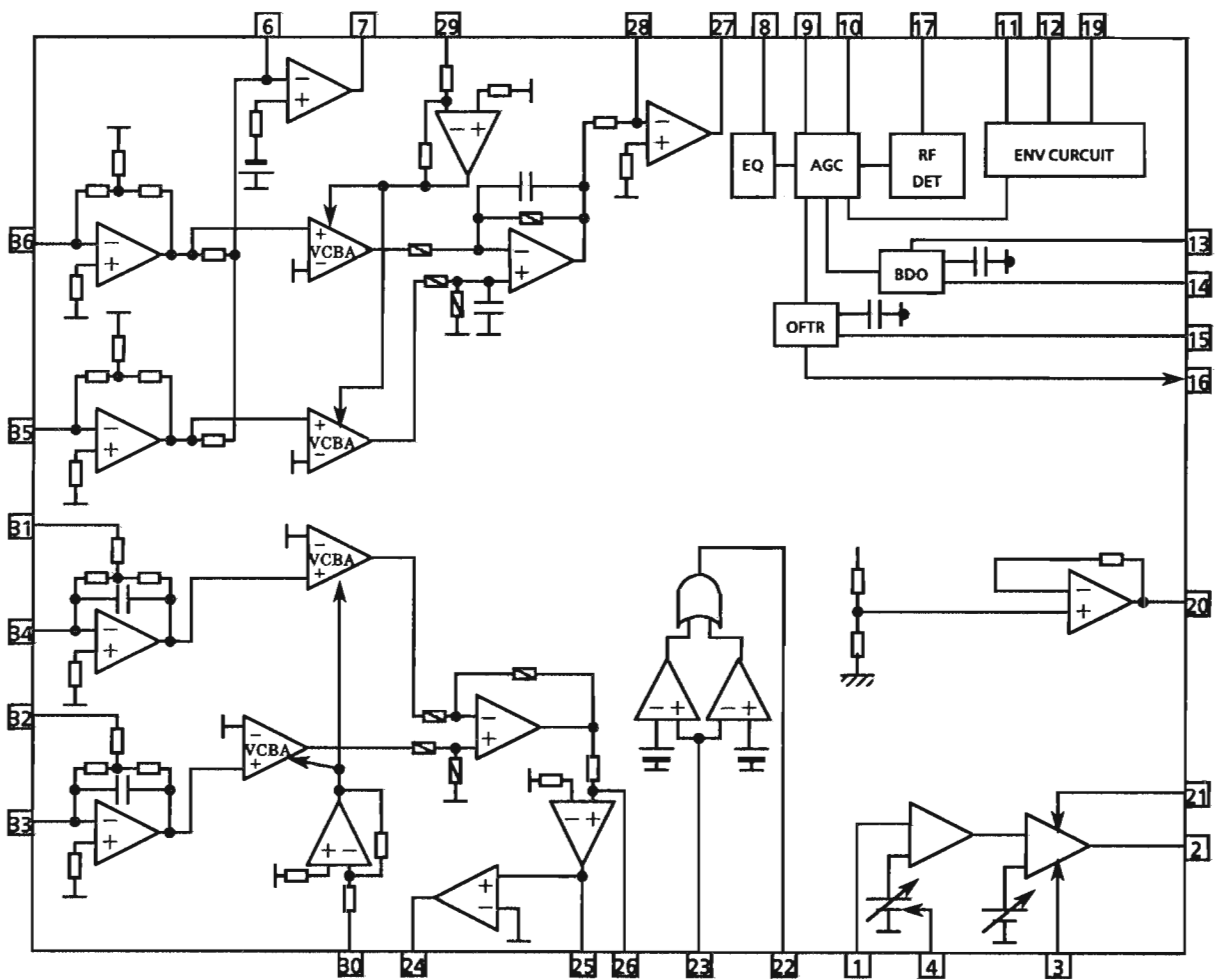

## 3. Functions

Pin No.	Symbol	I/O	Functions and operations
1	PD	I	APC amp input terminal
2	LD	O	APC amp output terminal
3	LD ON	I	APC ON/OFF control terminal
4	LDP	--	Connected to ground
5	VCC	--	Power supply
6	RF-	I	Inverse input pin for RF amp
7	RF OUT	O	RF amp output
8	RF IN	I	RF input
9	C.AGC	I/O	Connecting pin of AGC loop filter
10	ARF	O	RF output
11	C.ENV	I/O	A capacitor is connected to this terminal to detect the envelope of RF signal
12	C.EA	I/O	A capacitor is connected to this terminal to detect the envelope of RF signal
13	CS BDO	I/O	A capacitor is connected to detect the lower envelope of the RF signal
14	BDO	O	BDO output pin
15	CS BRT	I/O	A capacitor is connected to detect the lower envelope of the RF signal
16	OFTR	O	Of-track status signal output
17	/NRFDET	O	RF detection signal output
18	GND	--	Ground
19	ENV	O	Envelope output
20	VREF	O	Reference voltage output
21	LD OFF	--	Connect to ground
22	VDET	O	Vibration detection signal output
23	TE BPF	I	Input pin of tracking error through BPF
24	CROSS	O	Tracking error cross output
25	TE OUT	O	Tracking error signal output
26	TE-	I	Inverse input pin for tracking error amp
27	FE OUT	O	Output pin of focus error
28	FE-	I	Inverse input pin for focus error amp
29	FBAL	I	Focus balance control
30	TBAL	I	Tracking balance control
31	PDFR	--	Non connection
32	PDER	--	Non connection
33	PDF	I	I-V amp input
34	PDE	I	I-V amp input
35	PD BD	I	I-V amp input
36	PD AC	I	I-V amp input

# CA-D4T

## BA6397FPW(IC602) : BTL DRIVER

### 1. Terminal Layout

CH1-OUT A	1	28	GND
CH1-OUT B	2	27	CH4-OUT A
CH1-IN A	3	26	CH4-OUT B
CH1-IN B	4	25	CH4-IN A
TR-B	5	24	CH4-IN B
VREG-OUT	6	23	BIAS IN
MUTE	7	22	VCC
GND	8	21	VCC
CH2-IN B	9	20	CH3-IN B
CH2-IN A	10	19	CH3-IN A
CH2-OUT B	11	18	CH3-OUT B
CH2-OUT A	12	17	CH3-OUT A
GND	13	16	OP IN+
OP OUT	14	15	OP IN-

### 2. Block Diagram

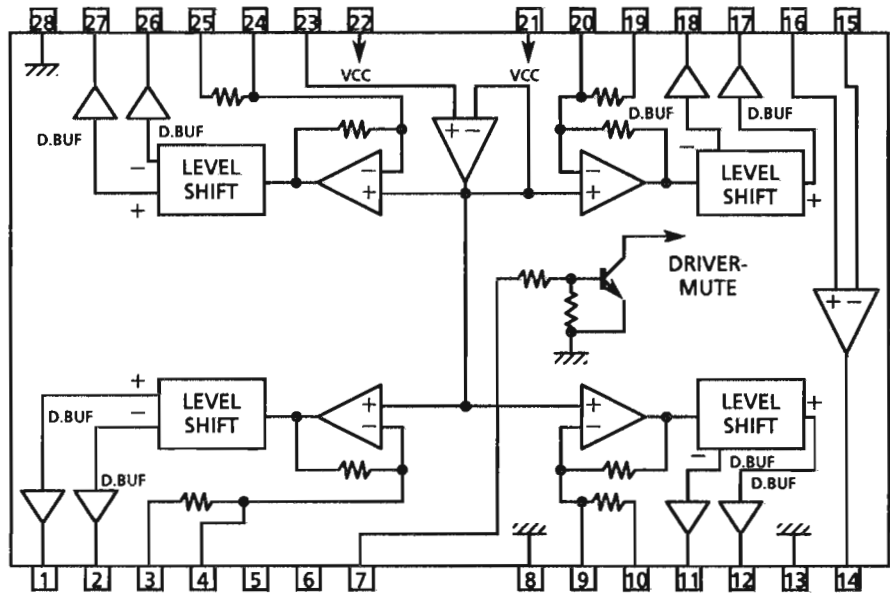

### 3. Description

Pin No.	Symbol	I/O	Description
1	CH1-OUT A	O	Focus drive output
2	CH1-OUT B		
3	CH1-IN A	—	Non connection
4	CH1-IN B	I	FOD input
5	TR-B	O	Transistor control
6	VREG-OUT	O	Reference voltage output
7	MUTE	I	Mute signal input pin
9	CH2-IN B	I	Spindle motor drive input Feed motor drive input
20	CH3-IN B		
11	CH2-OUT B	O	Spindle motor drive output
12	CH2-OUT A		
24	CH4-IN B	I	Feed motor drive input

Pin No.	Symbol	I/O	Description
8,13,28	GND	—	GND
10	CH2-IN A	—	Non connection
14	OPOUT		
15	OPIN-		
16	OPIN+		
19	CH3-IN A		
25	CH4-IN A		
17	CH3-OUT A	O	Feed motor drive output
18	CH3-OUT B		
21,22	Vcc	—	Power supply
23	BIAS IN	I	Input pin of Bias
26	CH4-OUT B	O	Tracking drive output
27	CH4-OUT A		

## TA8409F (IC802,IC803) : DC Motor driver

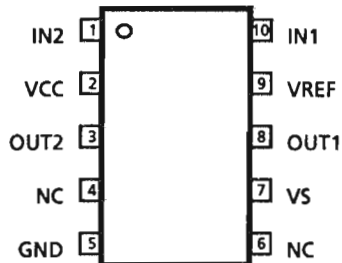

INPUT		OUTPUT		MODE
IN1	IN2	OUT1	OUT2	
0	0	∞	∞	stop
1	0	H	L	open
0	1	L	H	close
1	1	L	L	break

∞--High impedance

■ LC72131 (IC121) : PLL Synthesizer

1. Terminal Layout

XIN	1	22	XOUT
NC	2	21	VSS
CE	3	20	LPF OUT
DI	4	19	LPF IN
CK	5	18	PD
DO	6	17	VDD
$\overline{\text{FM}}$	7	16	FM OSC
$\overline{\text{AW}}$	8	15	AM OSC
LW	9	14	NC
AUTO/MONO	10	13	IF REQ
No use	11	12	FM/AM IF

2. Block Diagram

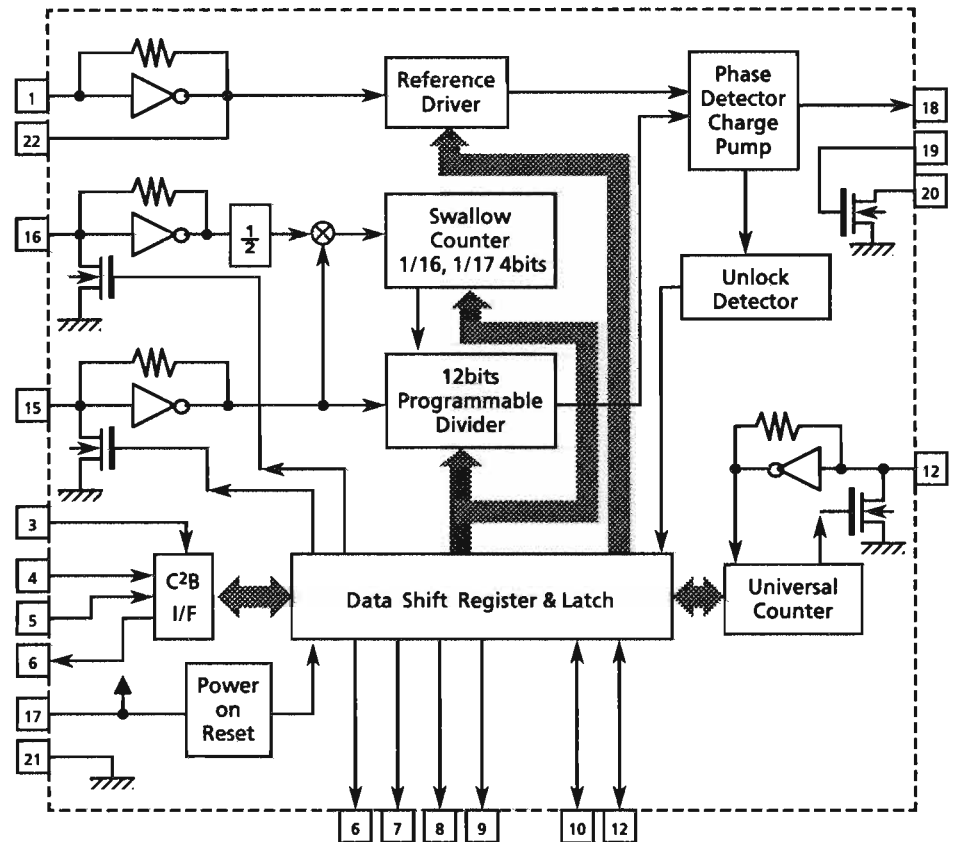

3. Pin Functions

Pin No.	Symbol	I/O	Functions	Pin No.	Symbol	I/O	Functions
1	X in	I	Crystal oscillator (7.2MHz).	12	FM/AM IF	I	Universal counter input
3	CE	I	Fix the chip enable to "H" when inputting (DI) and outputting (DO) the serial data.	13	IFREQ	O	Output the "IF-signal request" to IC102
4	DI	I	Receive the control data from the controller (IC701).	15	AM IN	I	Input the local oscillator signal of AM.
5	CK	I	This clock is used to synchronize data when transmitting the data of DI and DO.	16	FM IN	I	Input the local oscillator signal of FM.
6	DO	O	Transmit the data from LC72131 to the controller which is synchronized with CK.	17	VDD	--	This is a terminal of power supply.
7	$\overline{\text{FM}}$	O	It is "L" on FM mode.	18	PD	O	PLL charge pump output : When the local oscillator signal frequency is higher than the reference frequency high level signals will output. When it is lower than the reference frequency, low level signals will output. When it is same as reference frequency signals, it will be floating.
8	MW	O	It is "L" on MW mode.	19	LPF IN	I	Transistor used for the PLL active low-pass filter
9	LW	O	It is "H" on LW mode.	20	LPF OUT	O	Transistor used for the PLL active low-pass filter
10	$\overline{\text{AUTO/MONO}}$	O	It is "H" on monaural, "L" on auto.	21	VSS	--	Connected to GND
11	NO USE	O		22	X out	O	Crystal oscillator (7.2MHz).

■ LA1266 (IC104) : FM AM IF AMP & detector

1. The main function descriptions

- (1) Amplify and detect of FM intermodulation frequencies.
- (2) It has local oscillator and mixer for AM, and amplify the AM-IF signal.

2. Top View

3. Block Diagram

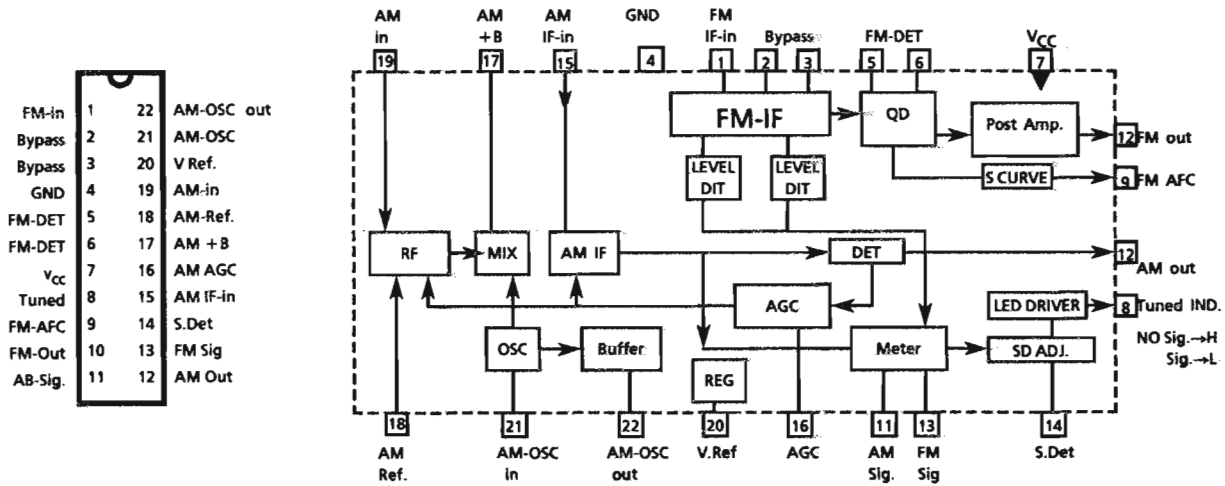

4. Pin Function Description

Pin No.	Symbol	I/O	Functions and Operations
1	FM in	I	This is an input terminal of FM IF Signal.
2,3	Bypass	--	Bypass of FM IF Amp.
4	GND	--	This is the device ground terminal.
5,6	FM DET	--	FM detect transformer.
7	V <sub>CC</sub>	--	This is the power supply terminal.
8	SIG	O	Auto-stop drive signal output for mute and tune
9	FM AFC	O	This is an output terminal of voltage for FM- AFC.
10	FM IF out	O	When the signal of IF REQ of IC121(LC72131) applied to pin12, the signal of FM IF does output.
11	AM IF out	O	When the signal of IF REQ of IC121(LC72131) applied to pin12, the signal of AM IF does output.
12	FM out	O	FM detection output.
13	STRQ	I	The IF-signals come out from pin10 (FM-IF) or pin11 (AM-IF) while this terminal going to "High".
14	NAR SM	--	Control the Band-width of signal meter.
15	AM out	O	AM detection output.
16	FM Adj	--	For adjust the stop level (or mute level) of FM.
17	AM Adj	--	For adjust the stop level (or mute level) of AM.
18	AM-IF	I	Input of AM IF Signal.
19	AM-AGC	I	This is an AGC voltage Input terminal for AM.
20	AM-MIX	O	This is an output terminal for AM mixer.
21	AM-IN	I	This is an input terminal for AM RF Signal.
22	V.REF	--	Resister value between pin9 and pin22 desides the frequency width of the inputsignal
23	AM-OSC	--	This is a terminal of AM Local oscillation circuit.
24	AM-OSC out	O	AM Local Oscillation Signal output.

■ LA3401 (IC105) : FM MPX Detector

1. The main function descriptions

- (1) Detect the FM Multiplex Signal (Stereo signal).
- (2) When receiving FM Stereo Signal, it outputs the signal for indicator.
- (3) AM/FM Audio Amplifier.

2. Terminal Layout

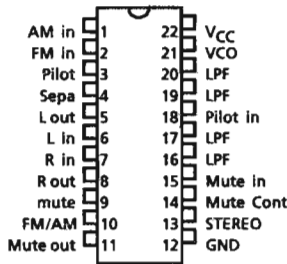

3. Block Diagram

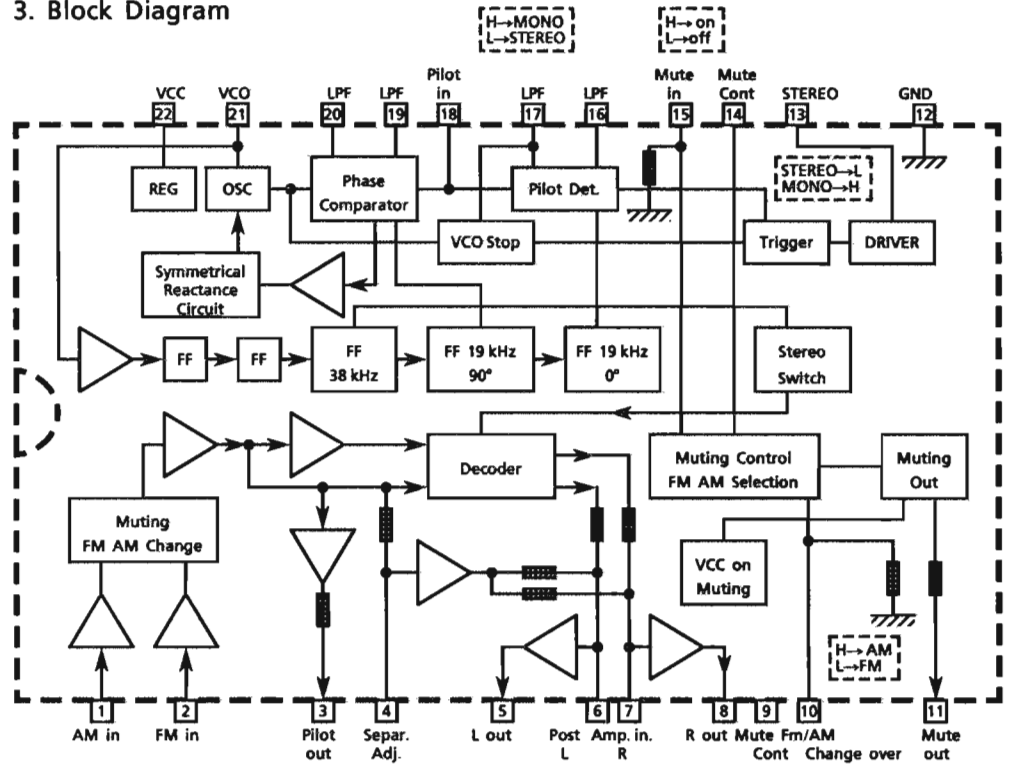

4. Pin Function Description

Pin No.	Symbol	I/O	Functions and Operations
1	AM in	I	This is an input terminal for AM detection signal.
2	FM in	I	This is an input terminal for FM detection signal.
3	Pilot out	O	Output of MPX pilot signal (Connect to Pin18).
4	Sepa. Adj.	--	Separation adjustment.
5	L. out	O	Left channel signal output.
6	L	O	Reversal output of Pin5.
7	R	O	Reversal output of Pin8.
8	R out	O	Right channel signal output
9	Mute Cont	--	The mute time is controlled by the connected capacitor when turning the power switch on.
10	/FM, AM	I	Change over the FM / AM input. "H" : AM, "L" : FM
11	Mute out	--	Not use
12	GND	--	Ground terminal.
13	/Stereo	O	Stereo indicator output. Stereo : "L", Mono : "H"
14	Mute Cont	--	The mute time is controlled by the connected capacitor when changing over the FM / AM .
15	Mute in	I	Mute signal input. "H" : Mute on, "L" : Mute off.
16	LPF	--	Low pass filter of pilot detector.
17	LPF	--	While this terminal goes to "H", the VCO stop.
18	Pilot in	I	Pilot input.
19	LPF	--	Low-pass filter of PLL.
20	LPF	--	Low-pass filter of PLL.
21	VCO	I	Voltage controlled oscillator terminal.
22	V <sub>CC</sub>	--	Power supply.

# Internal Connections of FL Display

■ ELU0001-210 : (FL701)

1. Grid Layout

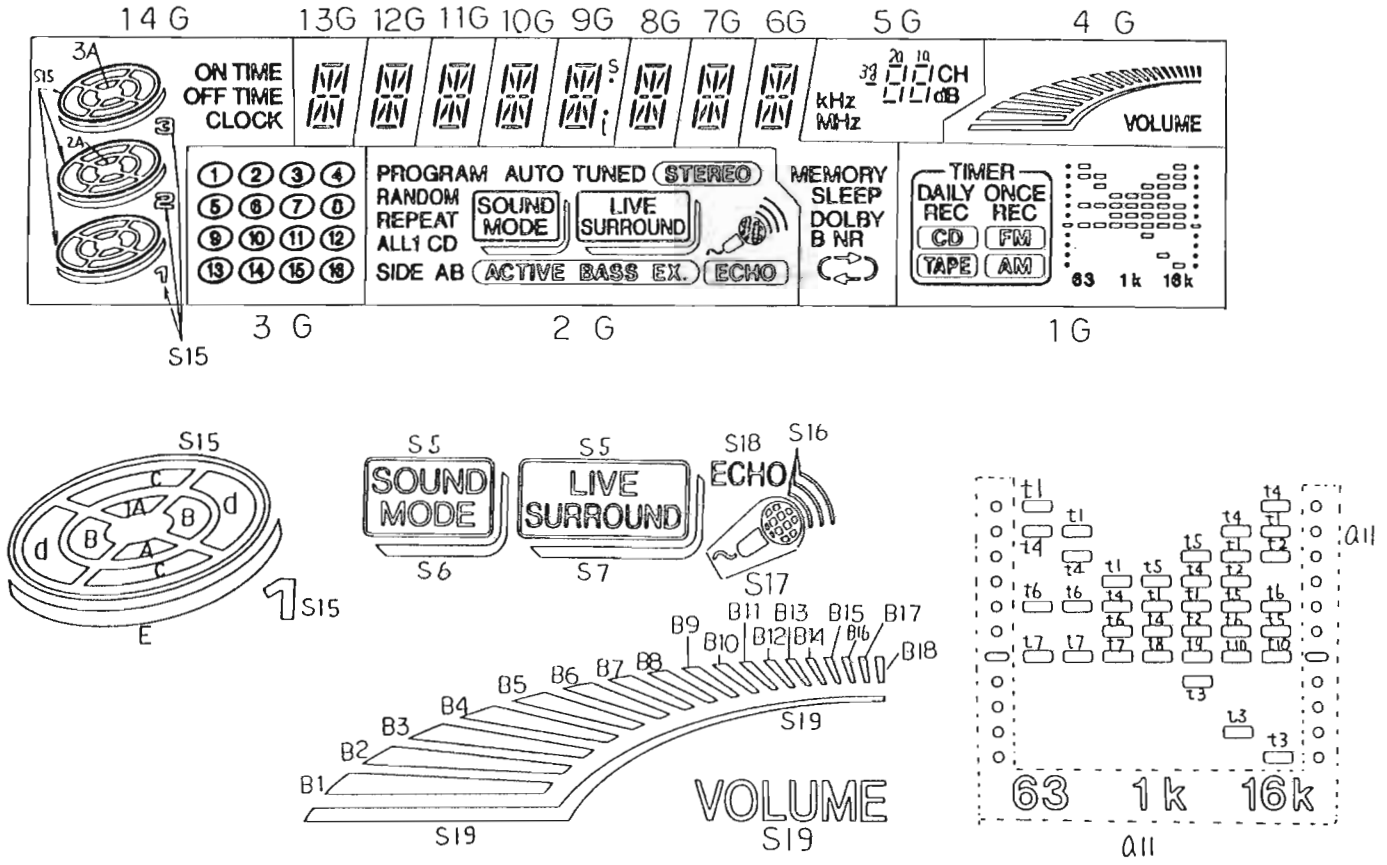

2. Pin Connections

TERMINAL NO.	1	2	3	4	5	6	7	8	9	10	11	12	13	14	15						
ELECTRODE	F1	F1	F1	NP	P <sub>s1</sub>	P <sub>s2</sub>	P <sub>s3</sub>	P <sub>s4</sub>	P <sub>s5</sub>	P <sub>s6</sub>	P <sub>s7</sub>	P <sub>s8</sub>	P <sub>s9</sub>	P <sub>s10</sub>	P <sub>s11</sub>						
TERMINAL NO.	16	17	18	19	20	21	22	23	24	25	26	27	28	29	30	31	32	33	34	35	
ELECTRODE	P <sub>s12</sub>	NP	NP	NP	NP	NP	NP	NP	P <sub>s11</sub>	1G	2G	3G	4G	5G	6G	7G	8G	9G	10G	11G	
TERMINAL NO.								36	37	38	39	40	41	42	43	44	45	46	47	48	49
ELECTRODE								12G	13G	14G	P <sub>s13</sub>	P <sub>s14</sub>	P <sub>s15</sub>	P <sub>s16</sub>	P <sub>s17</sub>	P <sub>s18</sub>	P <sub>s19</sub>	NP	F2	F2	F2

Notes F: Filament NP: No Pin  
 G: Grid  
 P: Anode



(3) Anode Designation

	1 G	2 G	3 G	4 G	5 G
S1	DAILY	TUNED		B18	CH
S2	ONCE	AUTO	①	B17	dB
S3		PROGRAM	②	B16	1a
S4	CD	RANDOM	③	B15	1b
S5	REC (ONCE )	S5	④	B14	1f
S6	FM	S6 (SOUND MODE )	⑤	B13	1g
S7	TAPE	S7(LIVE SURROUND )	⑥	B12	1c
S8	AM	REPEAT	⑦	B11	1e
S9	t1	CD	⑧	B10	1d
S10	t2	1	⑨	B9	2a
S11	t3	ACTIVE BASS EX	⑩	B8	2b
S12	t4	ALL	⑪	B7	2f
S13	t5	B	⑫	B6	2g
S14	t6	A	⑬	B5	2c
S15	t7	SIDE	⑭	B4	2e
S16	t8	S16 )))	⑮	B3	2d
S17	t9	S17( )	⑯	B2	KHz
S18	t10	ECHO		B1	MHz
S19	TIME	STEREO		S19	3g
all	all				

	6 G	7~8G	9G	10~13G	14G
S1	a	a	a	a	3A
S2	b	b	b	b	3B
S3	j	j	j	j	3C
S4	h	h	h	h	3D
S5	k	k	k	k	3E
S6	f	f	f	f	2A
S7	g	g	g	g	2B
S8	m	m	m	m	2C
S9	c	c	c	c	2D
S10	n	n	n	n	2E
S11	p	p	p	p	1A
S12	r	r	r	r	1B
S13	e	e	e	e	1D
S14	d	d	d	d	1E
S15	SLEEP		t		s15
S16	DOLBY B NR				ON TIME
S17	⇐				OFF TIME
S18	( )				CLOCK
S19	MEMORY		s		1C
all					

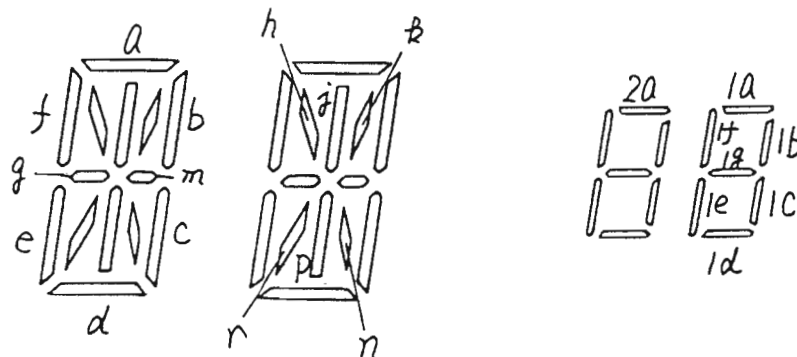

# Disassembly Procedures

- (1) Top cover and heatsink cover removal
1. Remove 6 screws (A) on the rear side and 2 screws (A) on both sides of the cover.
  2. Remove the 2 screws (B) holding the heatsink cover
  3. Remove the top cover and heatsink cover.

- (2) Rear panel removal
1. Remove the top cover.
  2. Remove the 2 screws (C) holding the CD changer mech. ass'y.
  3. Remove the 10 screws (B).
  4. Remove the rear panel.

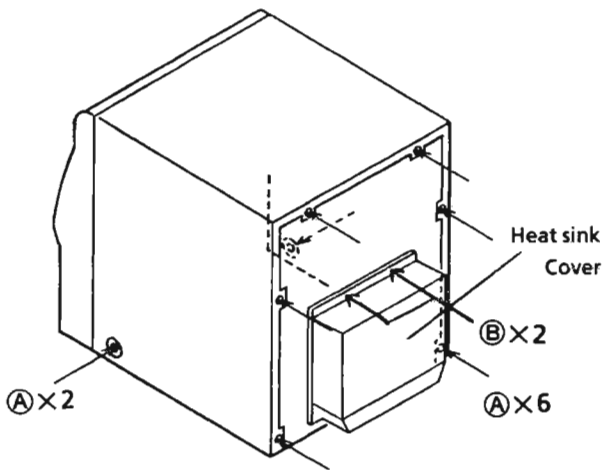

Fig 1

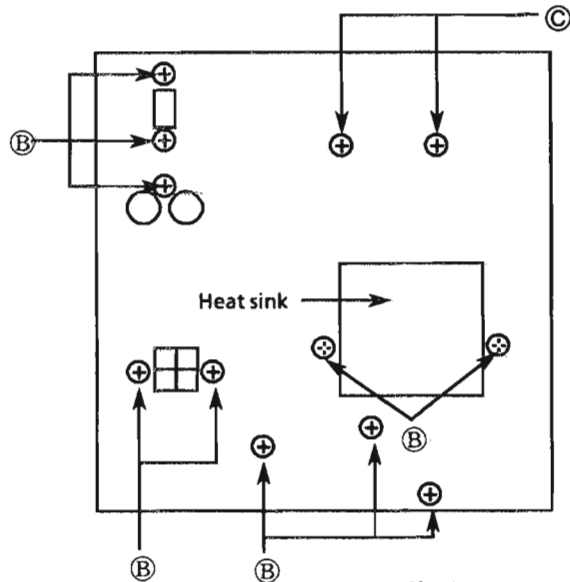

Fig 2 Rear view

- (3) CD changer mech. removal
1. Remove the rear panel.
  2. Disconnect the CN603, CN604, CN801.
  3. Remove the 2 screws (D) holding the CD changer mech. .
  4. Remove the CD changer mech. ass'y.

- (4) Tuner & Audio PCB (FMC-002-1) removal
1. Remove the CD changer mech. ass'y.
  2. Remove the plastics rivet and Remove the FMC-002-4.
  3. Disconnect CN401(Flat wire) , CN514.
  4. Disconnect CN513 and CN514.
  5. Remove the Tuner & Audio PCB (FMC-002-1).

**[Note]**

Changer mech. ass'y needed connect the main PCB When servicing, so that the set can be movement.

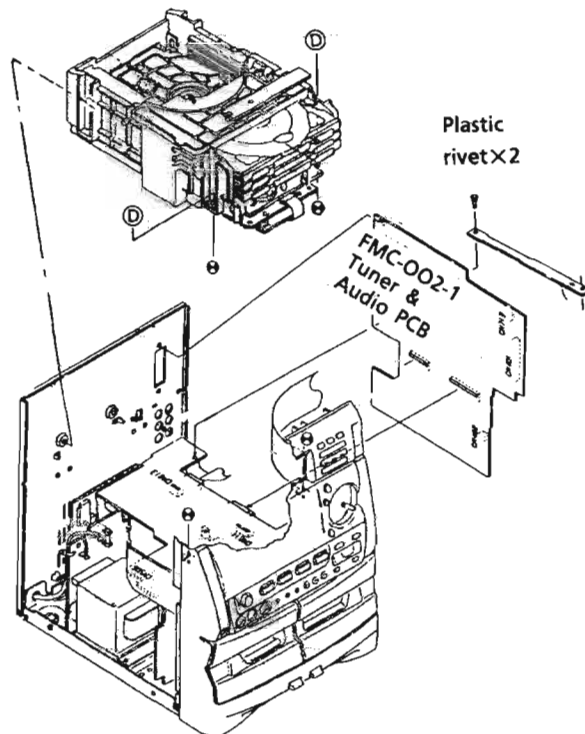

Fig 3 FRont view

(A) .. SDSG3006M (B) .... E73273-003 (C) ... SBSF3008Z (D) ... SBSG3008Z

(5) Deck & CD control PCB (FMH-005-1) removal

1. Remove the (1)(2)(3)(4).
2. Disconnect the CN901.
3. Remove the 3 screws (E) holding the PCB and Remove the plastics rivet.
4. Raise up the PCB for disconnecting and you can remove the Deck & CD control PCB with the power AMP PCB.

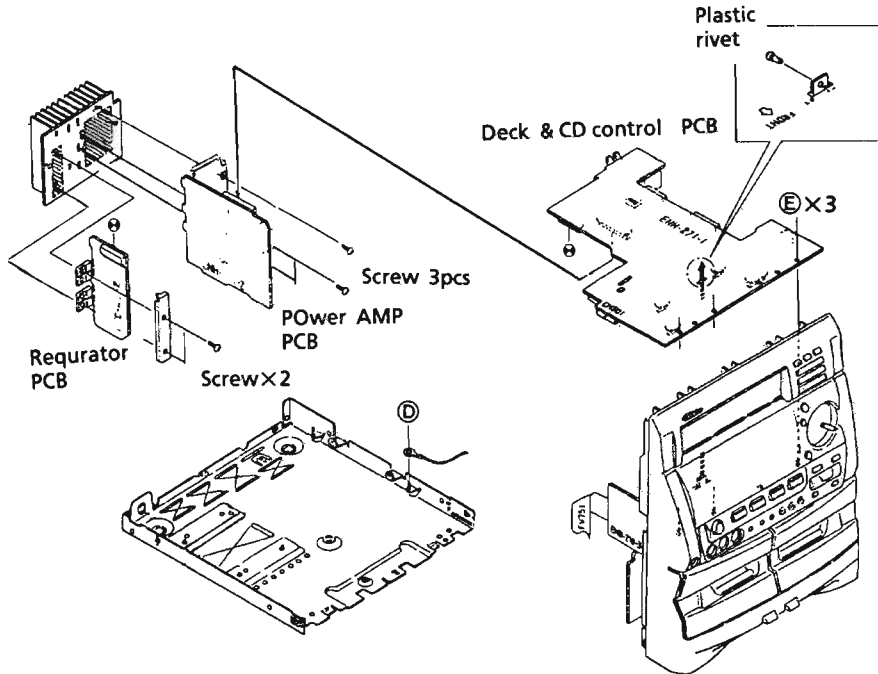

Fig 4

(6) Front PCB (FMB-006-1) removal.

1. Remove the (1)(2)(3)and(4) (5).
2. Remove the 3 Fook of the bottom side and both side and Remove the Front panel ass'y.
3. Remove the 15 screws (F) holding the braket .
4. Remove the Braket and Front PCB.

(7) Switch PCB(FMB-006-2) removal .

1. Remove the (1)(2)(3)and(4)(5)(6).
2. Remove the 7 screws holding the PCB .
3. Remove the Switch PCB with the headphone PCB .

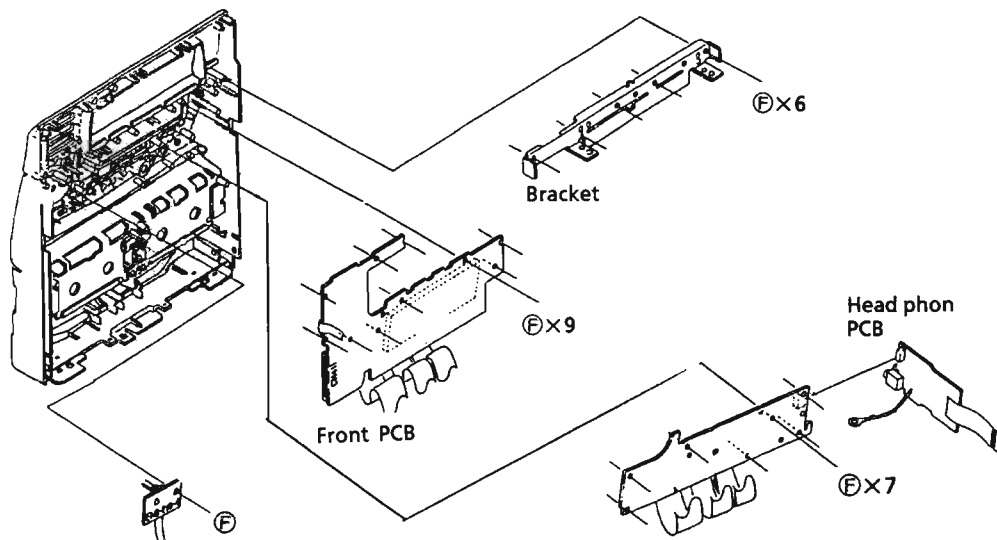

Fig 5

(E) .. SPST2604Z

(F) ... CDSF2608Z

**(8) Cassette mechanism with the PCB (FMC-002-3) removal**

1. Remove the (1)(2)(3)and (4)(5).
2. Remove the 4screws ③ and 4screws ④.
3. Remove the Cassette mechanism.

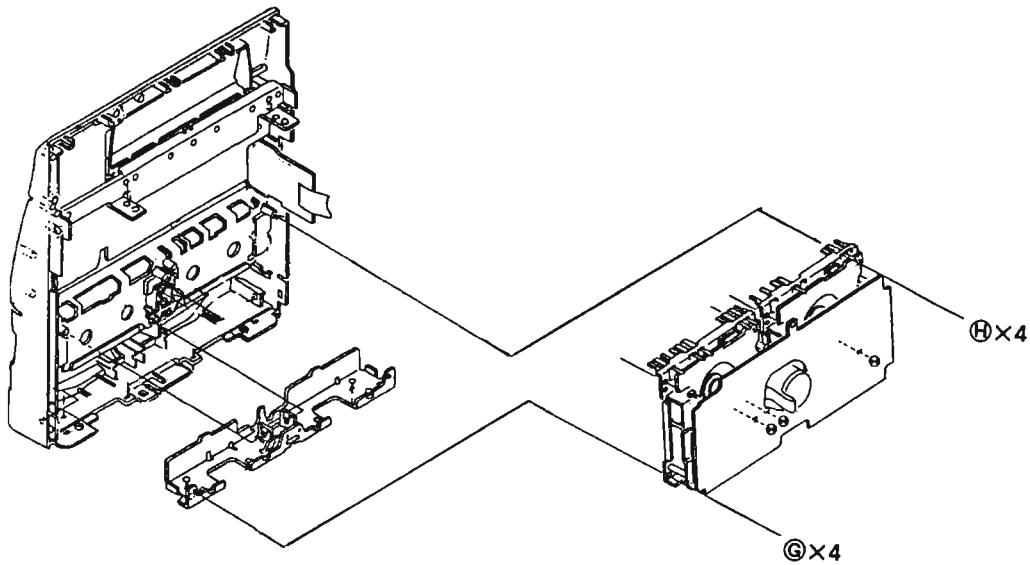

Fig 6

**(9) Cassette deck PCB (FMC-002-3) removal**

1. Remove the (1),(2),(3)and (4),(5),(8).
2. Disconnect the CN331 and CN332.
3. Remove the 2 screws ⑤ holding the PCB.
4. Remove the Cassette deck PCB .

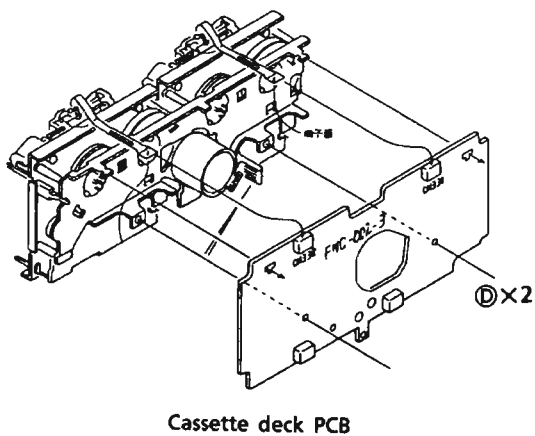

Fig 7

**(10) Cassette door lock plate removal**

1. Remove the (1)(2)(3)and (4),(5),(8) .
2. Remove the spring.
3. Push up the Elever as shown in the figure below(Fig .8) and remove the door lock plate.

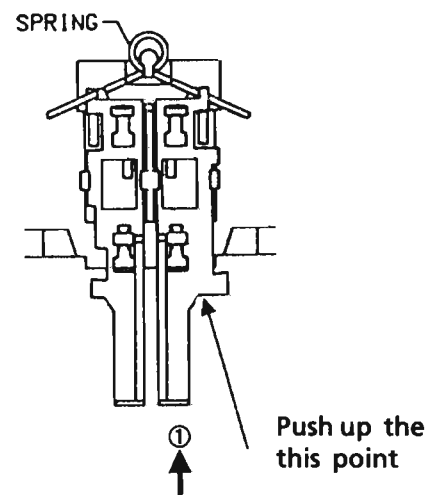

Fig 8

⑤ .. SBSG3008Z      ③ ... SBST3006Z      ④ ... SBSF3008Z

**(13)** Damper removal

1. Remove the cassette mechanism.
2. Remove the spring holding the cassette holder.
3. Press the tab which secures the damper to remove the damper. (See the arrow shown in the figure below)

**(14)** Cassette holder removal

1. Remove the Cassette mechanism assembly.
2. Remove the spring holding the cassette holder.
3. Remove the Cassette holder .

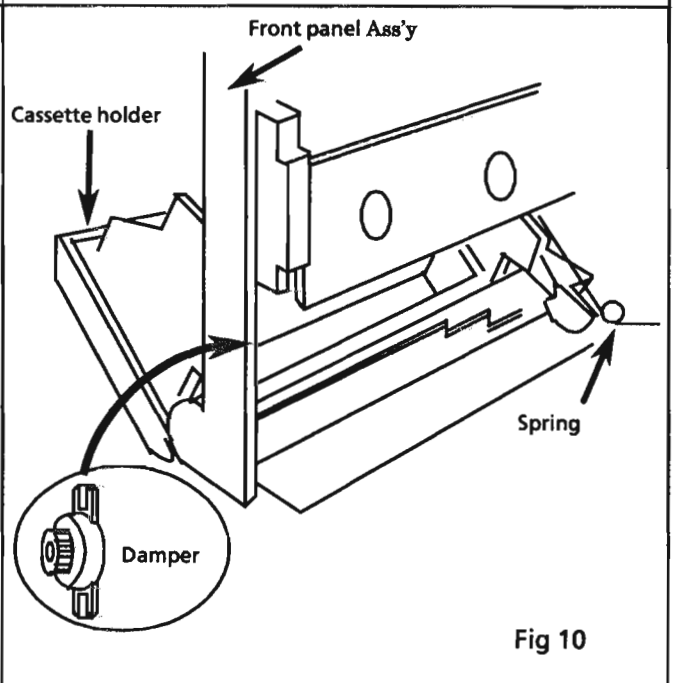
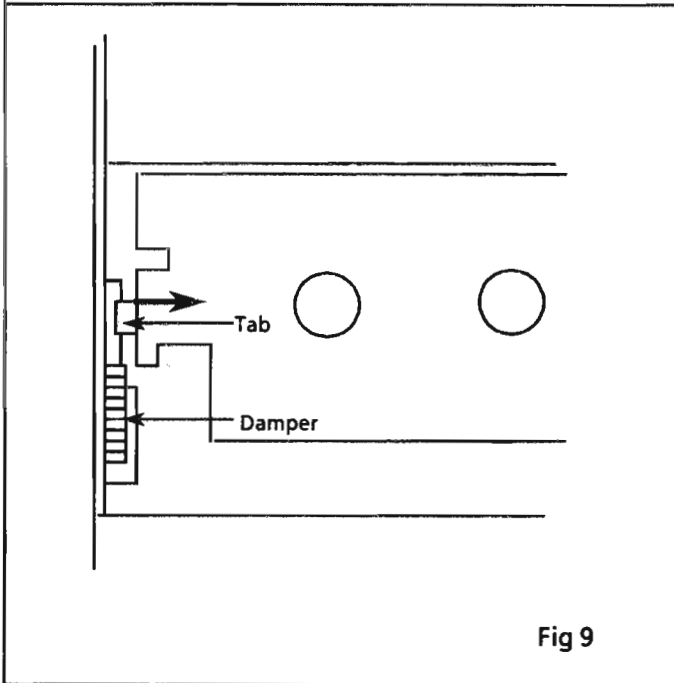

# Cassette Mech. Ass'y removal

- (13) Head assembly removal
1. Remove the Cassette mech. ass'y.
  2. Remove the Flexible wire from the cassette deck and remove the 3 screws ① holding the head Ass'y.

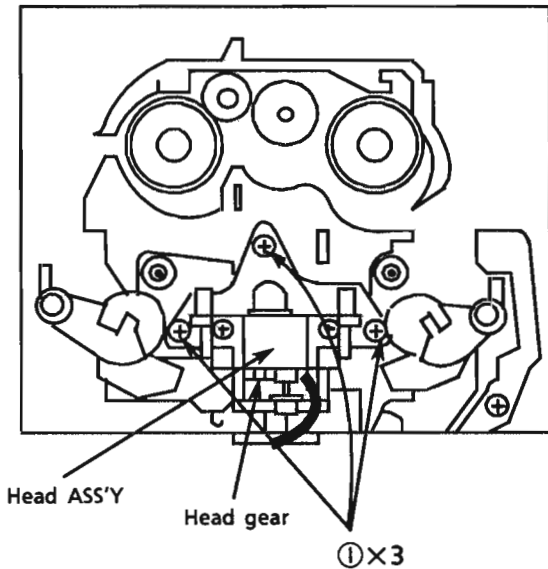

Fig11 Cassettem mech. bottom view

- (15) Pinch roller(FWD/REV) removal
1. Remove the cassette mech. assembly.
  2. Remove the hook holding the pinch roller.
  3. Remove the pinch roller ass'y.

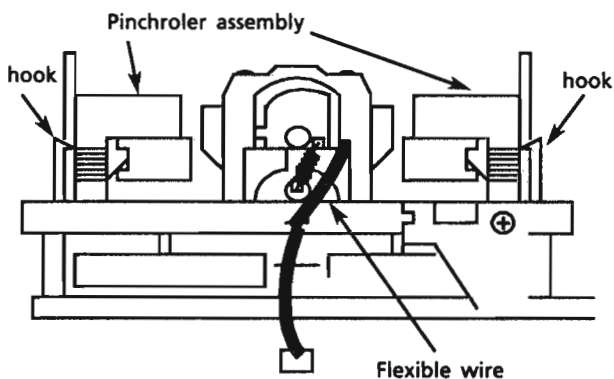

Fig 13 Cassette mechanism bottom view

- (14) Head assembly
1. The direction of the head is changed with the direction lever. When servicing, install the direction lever according to the direction of the head assembly.

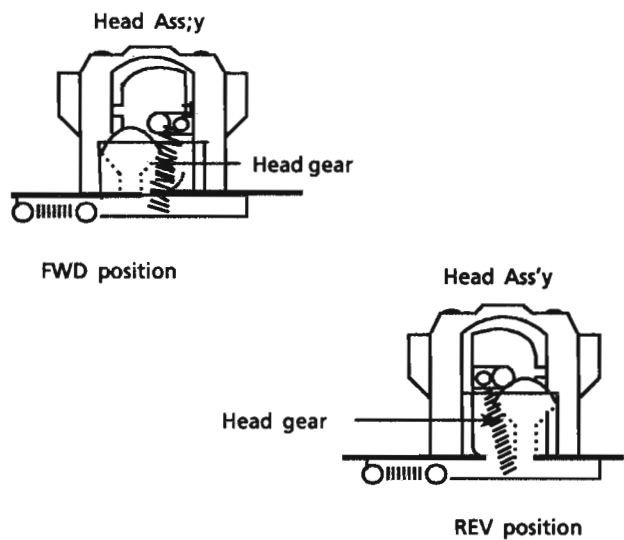

Fig.12-A Head Ass'y side view

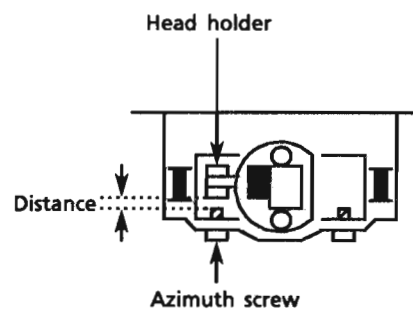

Fig.12-B A distance of between head older and azimuth screw

① .. SDSF2608Z

(16) Capstan motor removal.

1. Remove the cassette mechanism.
2. Remove the cassette deck control PCB.
3. Remove the 6 screws ① holding the bracket.
4. Remove the hooks (■) of the bracket.
5. Put the cutting on the flywheel A together the bracket's pawl as shown in Fig.16(Flywheel A) and check that the flywheel B is removed from the bracket's pawl(Fig.16-Flywheel B).
6. Remove the capstan motor with the bracket.
7. Unsolder the broken flat wire of the capstan motor.
8. Remove the 2 screws fixing the motor and the bracket.

\* To remove the bracket, it is easier to remove mech."B" first.  
Vice versa, assembling mech."A" is easier for reassembly.

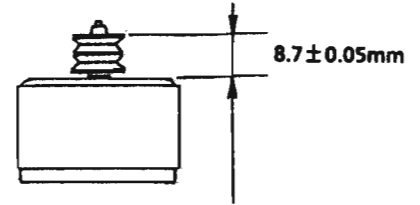

Fig 14 Capstan motor pulley installation

(17) Flywheel removal

1. Remove the cassette mechanism assembly.
2. Remove the cassette amp PCB.
3. Remove the 6 screws ① and the bracket.
4. Remove the 4 hooks of the bracket.
5. Remove the bracket.
6. Remove the flywheels.

\*The oil on the capstan must be wiped out after re-assembling.

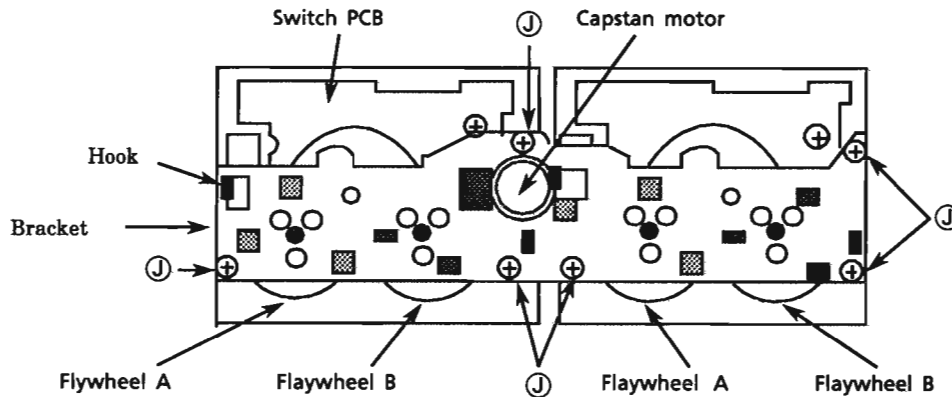

Fig. 15 Cassette mech. bottom view

Cutting on the flywheel

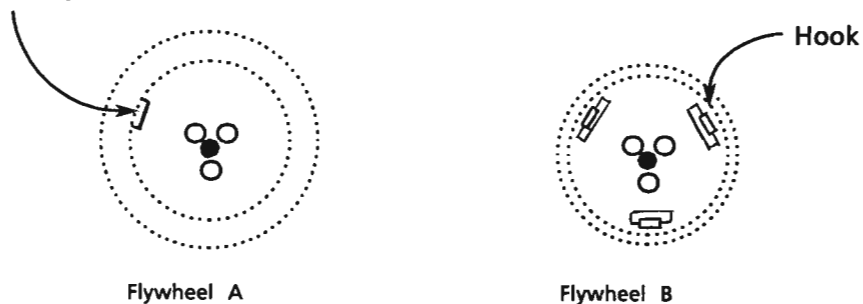

Fig 16 Hook and Cutting on the flywheel

(18) How to install the belts

1. Install the flywheels and belts as shown in the figure below . ( Fig 17 )  
When putting the belts, put the long belt first.
2. Install the main reels to put the belts on the flywheels.

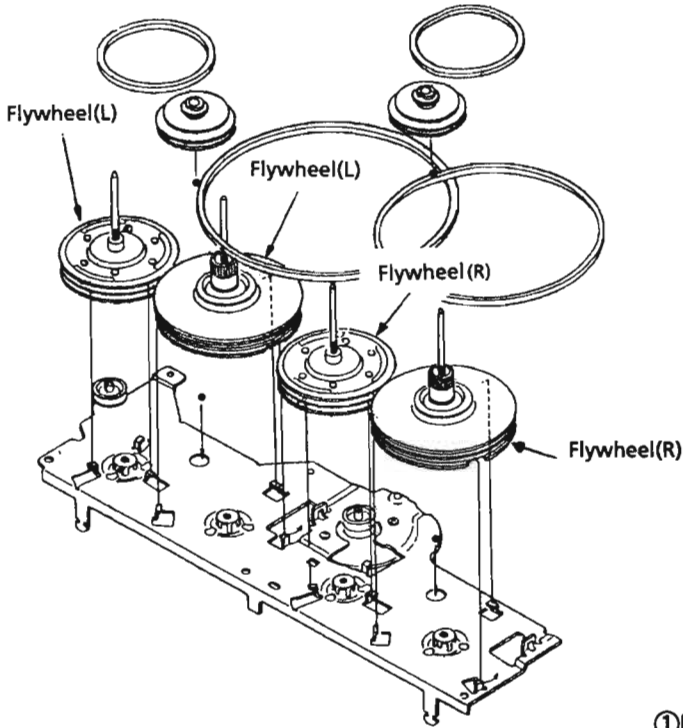

Fig 17-A Install the Braket and flywheels

REEL BELTS

After hooking reel belts, no twist .

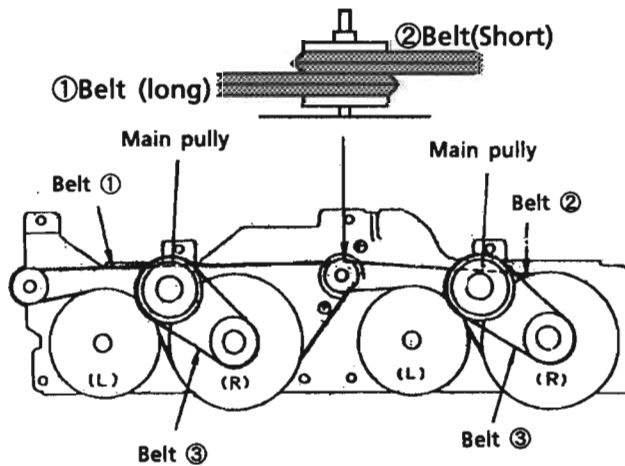

Fig 17-B Install the Belts

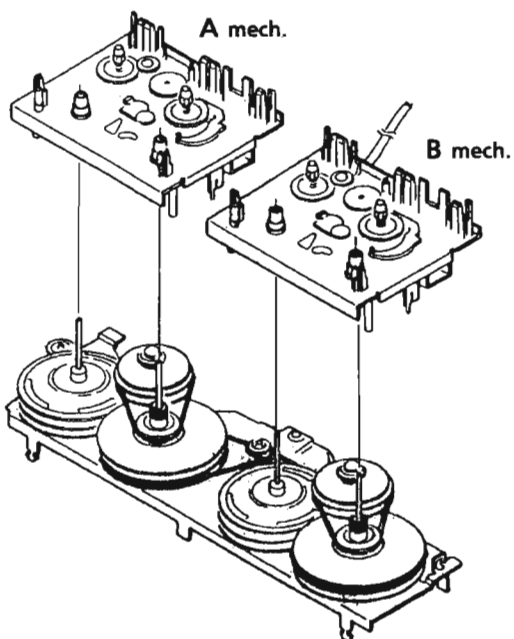

Fig 17-C Insdtall the cassette emch.



**(19) Switch PCB removal**

1. Remove the flywheel.
2. Remove the 1 screw ①.
3. Unsolder the broken solenoid.
4. Release the 4 hooks holding the Switch PCB.
5. Remove it.

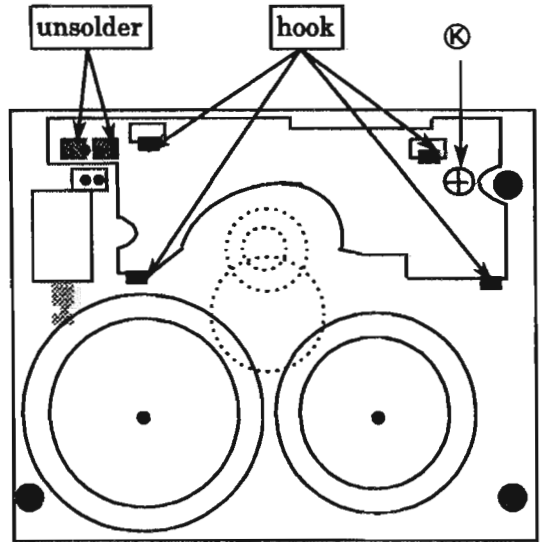

Fig 18 Cassette mech. bottom view

**(20) How to install the cassette mechanism**

Install the parts as shown in the Fig.19 .

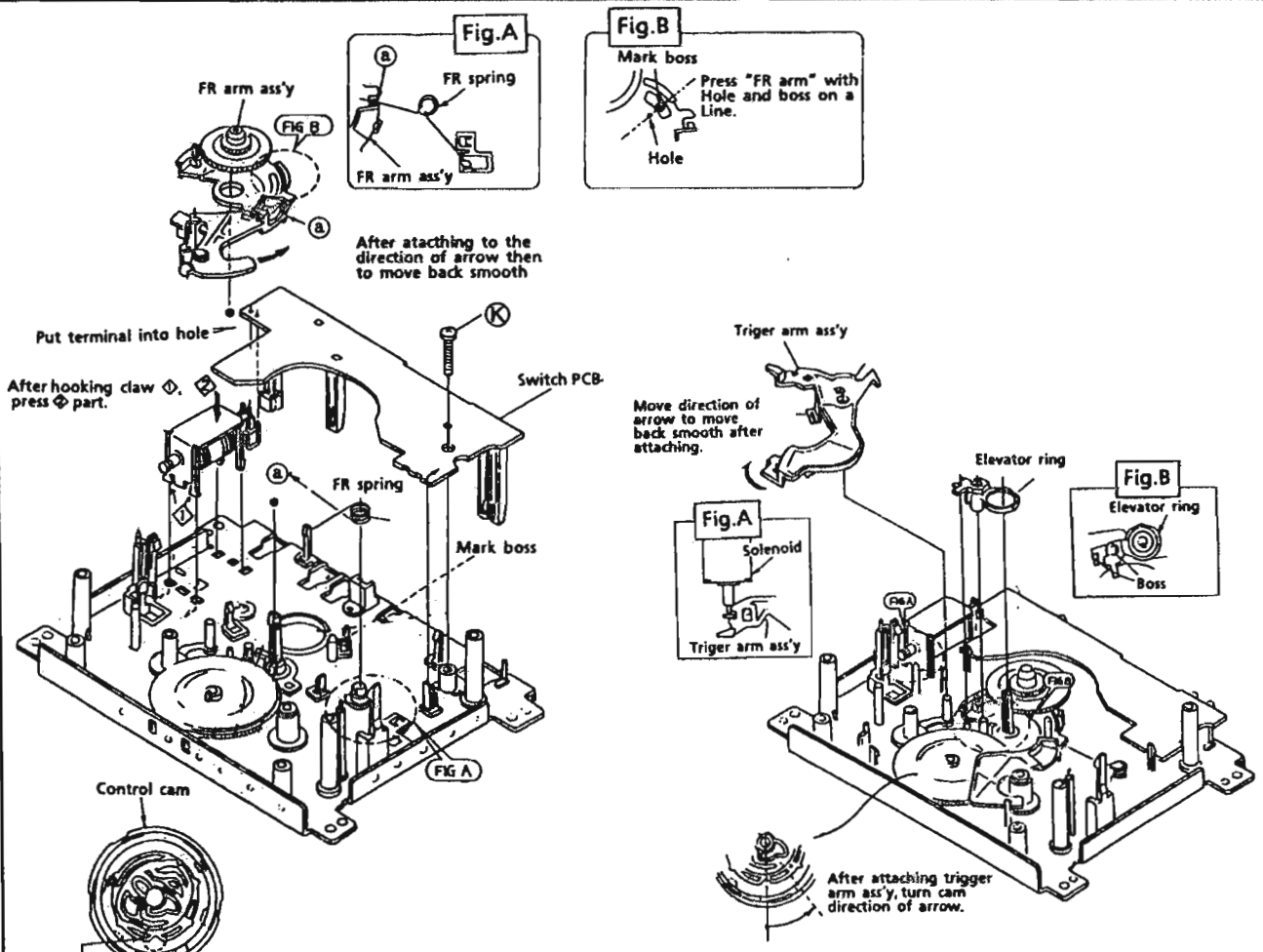

Fig 19 Install the link and arm ass'y

① .. SDST2612Z

## CD changer mech. Ass'y removal

### (21) CD Tray assembly removal

1. Disassemble the changer mech..
2. Remove the screw ① holding the stopper bracket.(See Fig.20) --- (U.S.A and CANADA only)
3. Remove the rod from both ends' hooks which are secured on T.Bracket ③ and clamber base④.(See Fig. 20)
4. Remove 3 screws② securing T.Bracket.(See Fig. 22.)
5. Remove a screw ⑤securing center of the clamper ass'y.(See Fig. 21)
6. Remove the clamper ass'y from ★ screw fixing side.
7. Remove a screw ⑥which secures the return spring and lock levers from the chassis ass'y.(See Fig. 23.)
8. Remove 2 pawls④ which slightly secure the return spring to remove it.
9. Remove 3 lock levers.
10. Check that the lifter unit stopper is inserted into hole ⑦ located on CD tray ass'y. (See Fig. 24.)
11. Check that the driver unit elevator is seen from a hole (marked ⑧) on left side of the CD changer mech..(See Fig. 25 and 26.)  
[NOTE] Set the elevator in correct position (Fig. 26) by rotating the pulley gear with finger if it is not positioned correctly (Fig. 27.).
12. Rotate the motor pulley clockwise with finger until the lifter unit's stopper is lowered from ⑦hole located on the CD tray ass'y. (See Fig. 27.)
13. And, pull all 3 CD tray assemblies forward until they stop. (See Fig. 25.)
14. Press 2 pawls(f, f') located rear side of the CD tray ass'y according to an arrow⑨ to remove the CD tray ass'y. (See Fig. 28.)  
At first, removing the lowest tray is easier.

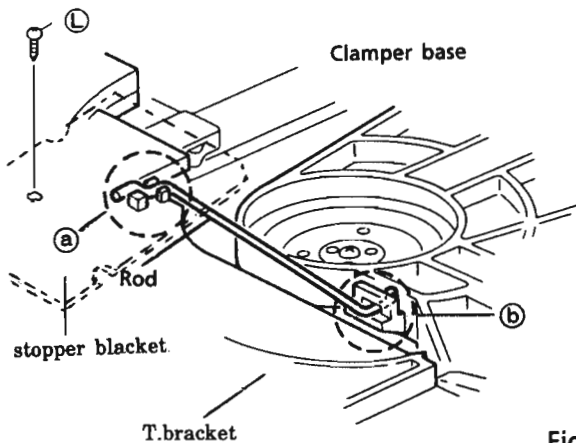

Fig. 20

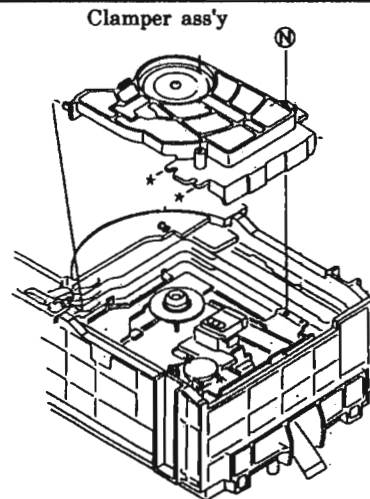

Fig.21

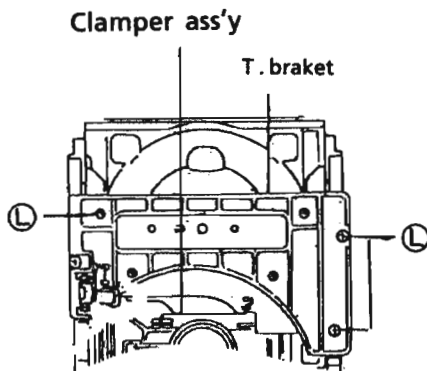

Fig.22

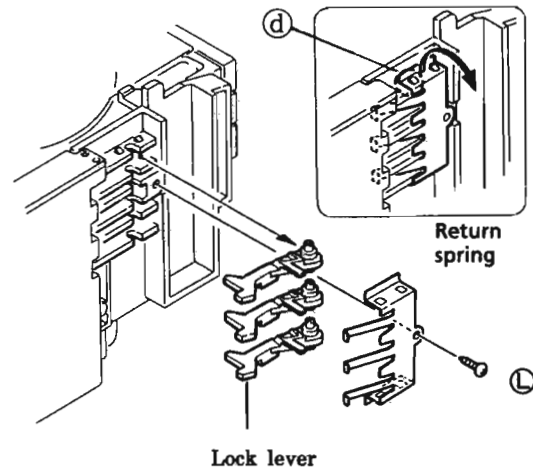

Fig.23

① .. SBSF2608Z      ⑤ ... SPST2606Z

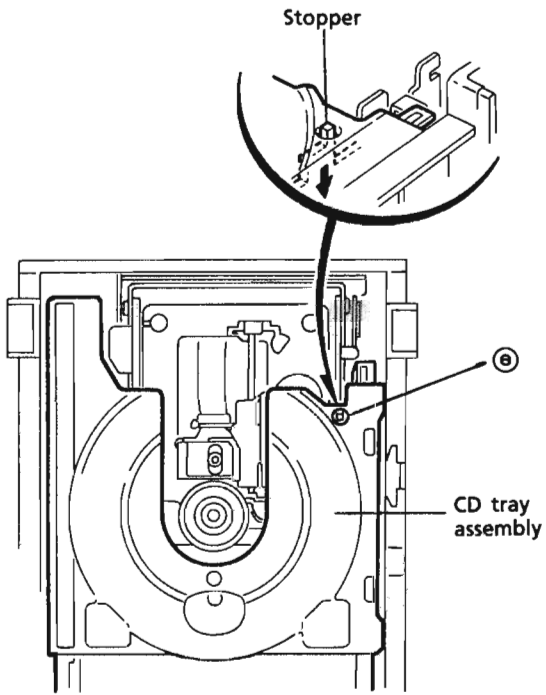
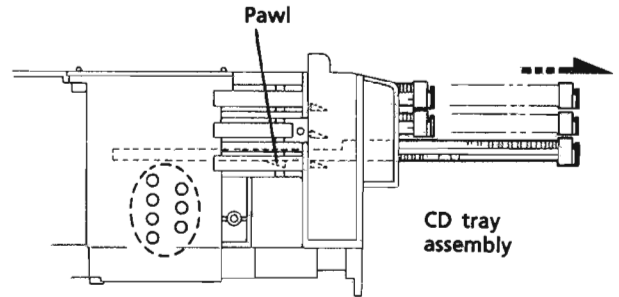

Fig. 24



See Fig.26 assembly

Fig. 25

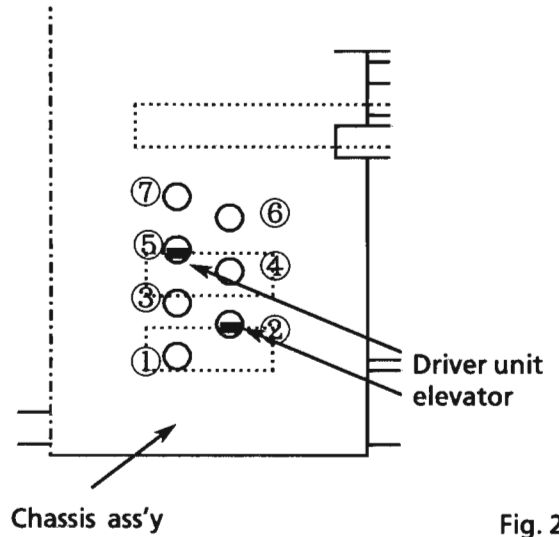

Fig. 26

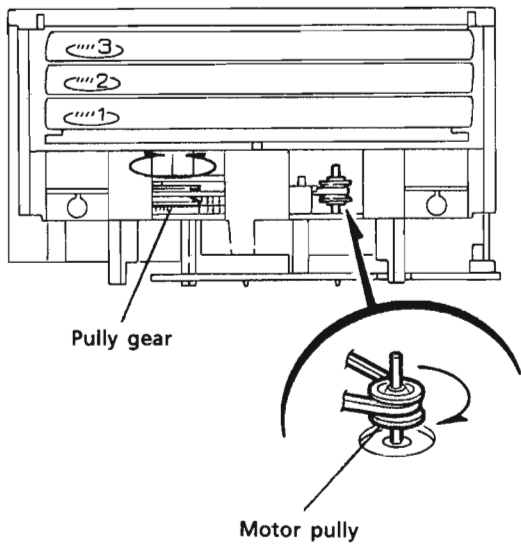

Fig. 27

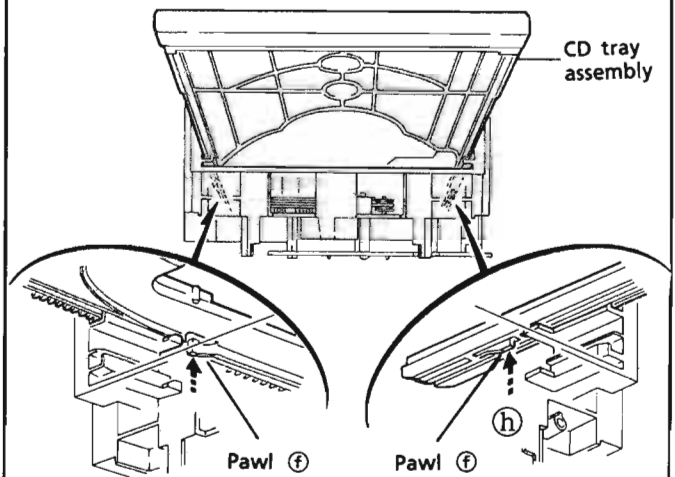

Fig. 28

(22) CD mechanism removal

1. Remove the CD tray ass'y.
2. Rotate the Cam R1, R2 ass'y counterclockwise so that CD mech. ass'y's shaft (h) is positioned as shown in Fig. 29.
3. Remove 4 screws (L) securing CD mech. ass'y. (See Fig. 29.)

\*How to replace pick-up unit

1. If CD mech. is removed without disassembling CD mech. ass'y, rotate the Cam R1, R2 ass'y clockwise to set the CD mech. ass'y's shaft(L) as shown in Fig. 30.
2. Lift the CD mech. ass'y toward the direction (i) to remove it from the lifter unit. (See Fig. 31.)

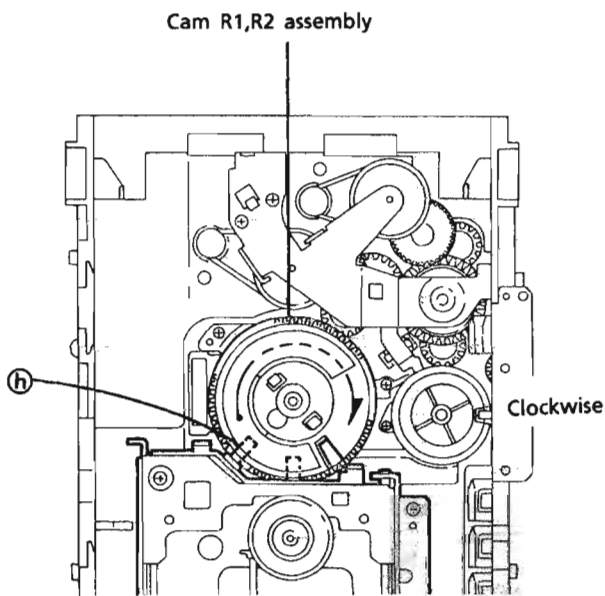
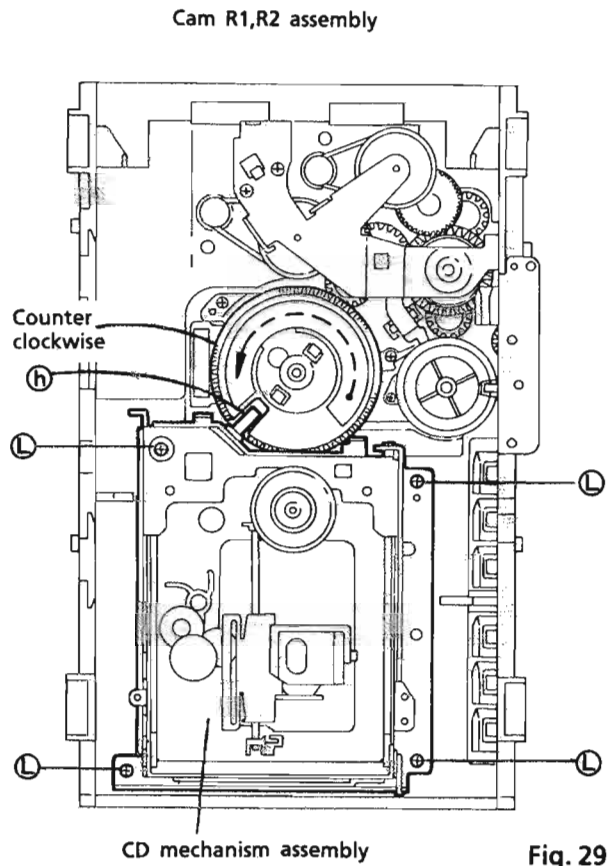

Fig. 30

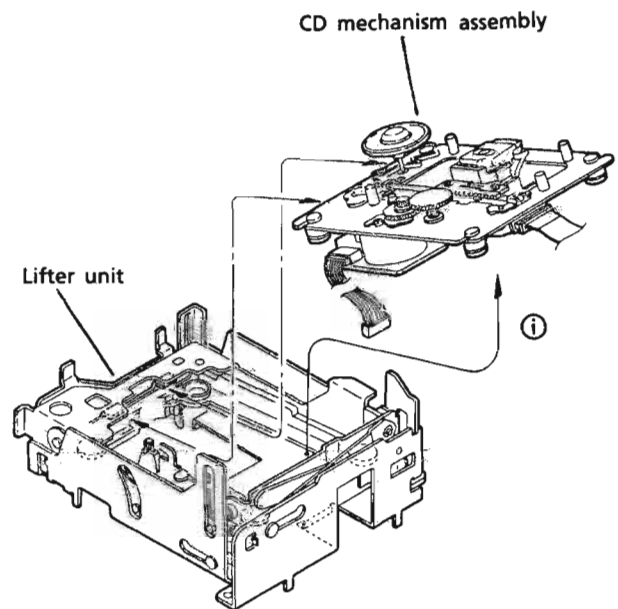

Fig. 31

(L) .. SBSF2608Z

**(23) Actuator motor board removal**

1. Unsolder 4 soldered point ① for both motors. (See Fig. 32.)
2. Remove a screw ④ securing the CD servo board. (See Fig. 32.)
3. Press the hook and release it to remove the CD servo board.
4. Remove 2 screws ② securing the actuator motor board. (See Fig. 32.)
5. Remove 2 screws ③ securing the tray select switch board. (See Fig. 33.)

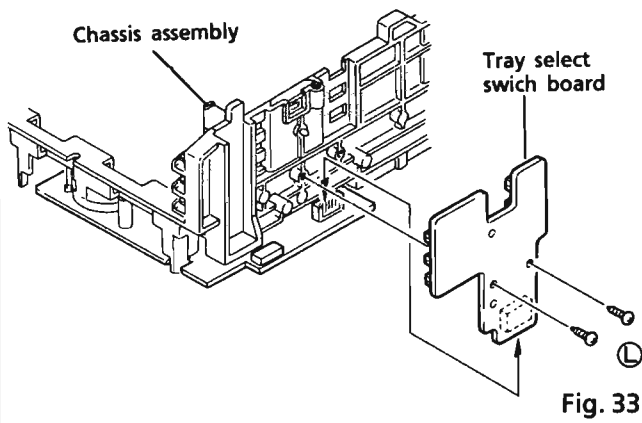

Fig. 33

**(24) Cam unit removal**

1. Disassemble CD mech. ass'y.
2. Rotate the Cam gear L so that the drive unit's pawl ① is positioned as shown in Fig. 34.
3. Remove the drive unit and cylinder gear. (See Fig.35.)
4. Rotate the Cam gear L so that the select gear's ② is positioned as shown in Fig.36.
5. Remove 4 screws ② securing the cam unit which includes the cam gear L and Cam R1, R2 ass'y. (See Fig 36.)

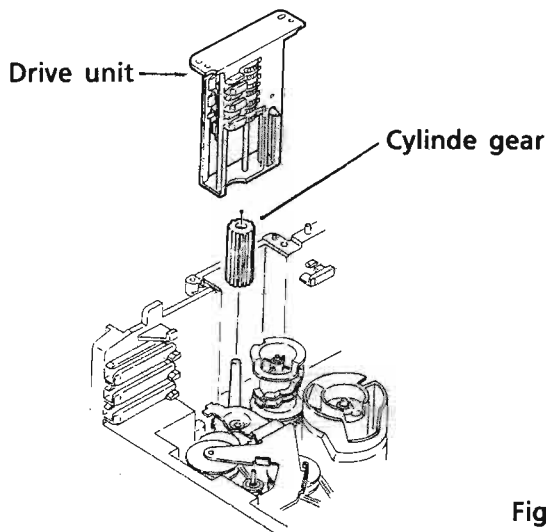

Fig. 35

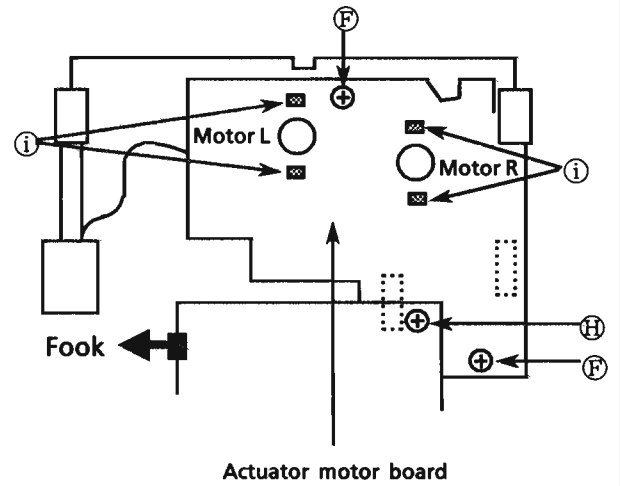

Fig. 32

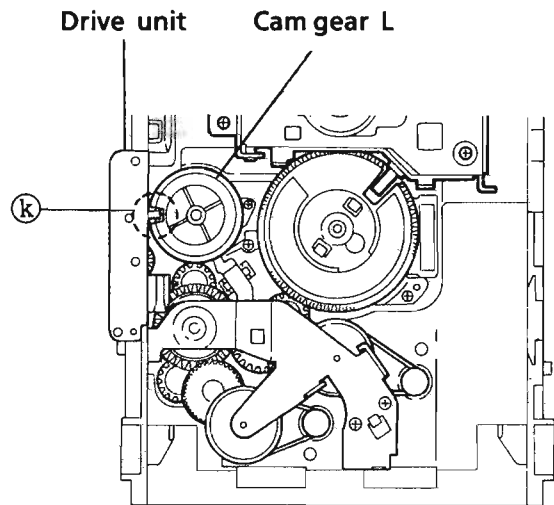

Fig. 34

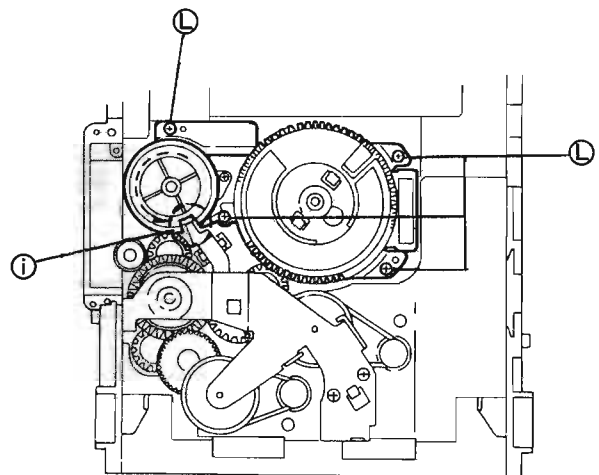

Fig. 36

② .. SBSF2608Z      ④ ... SBSF3008Z

(25) Removal for actuator motor and belt

1. Remove 2 screws (P) securing the gear bracket. (See Fig. 37.)
2. Press the pawl (M) securing the gear bracket to the arrow in the figure to remove the gear bracket. (See Fig. 37.)
3. Remove the gear bracket from the chassis ass'y's (N) securing top of the gear bracket. (See Fig. 38.)
4. Remove each belts from the both actuator motor pulleys and the pulley gears. (See Fig. 37.)
5. Reverse the chassis ass'y and widen 4 pawls (O) which secure both actuator motors to its arrows to remove the actuator motors. (See Fig. 39.)

[NOTE] The pulley gears and other gears which consist the gear unit may drop separately if the chassis ass'y is reversed without gear bracket and belt. See Fig. 40 to assemble them again.

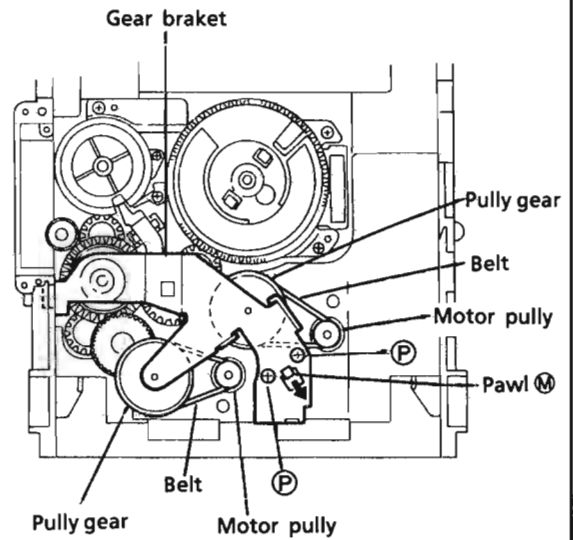

Fig. 37

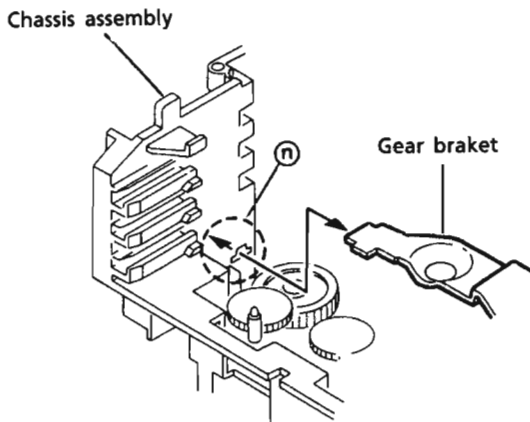

Fig. 38

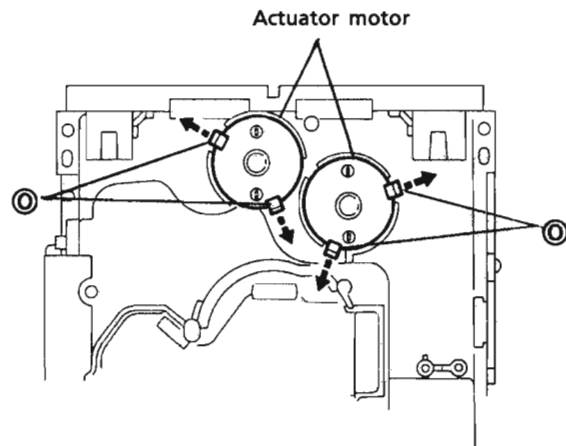

Fig. 39

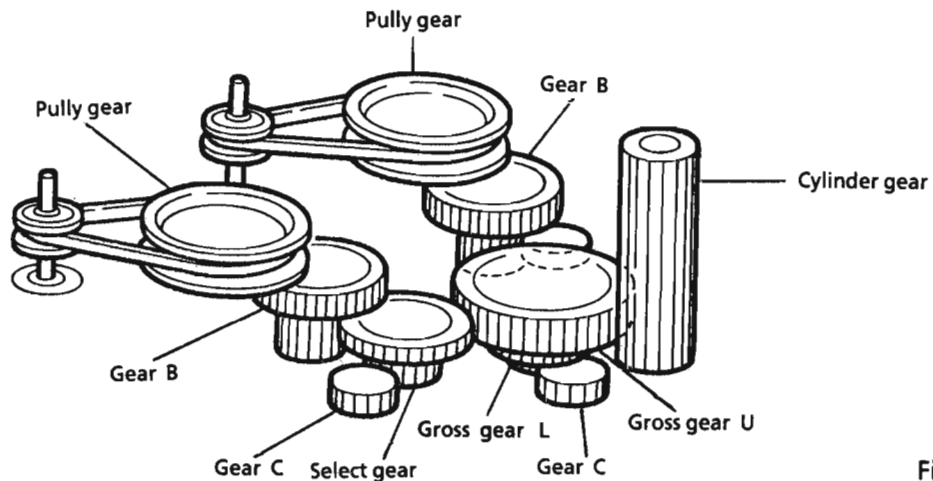

Fig. 40

(P) .. DPSP2616Z

(26) Removal of cam R1, R2 ass'y and cam gear L

1. Remove the slit washer securing Cam R1, R2 ass'y.  
(See Fig. 41.)
2. Remove 2 pawls ④ securing Cam R1 to remove Cam R2 from Cam R1.
3. Remove the slit washer securing Cam gear L.
4. Remove Cam gear L from the C.G. base ass'y.

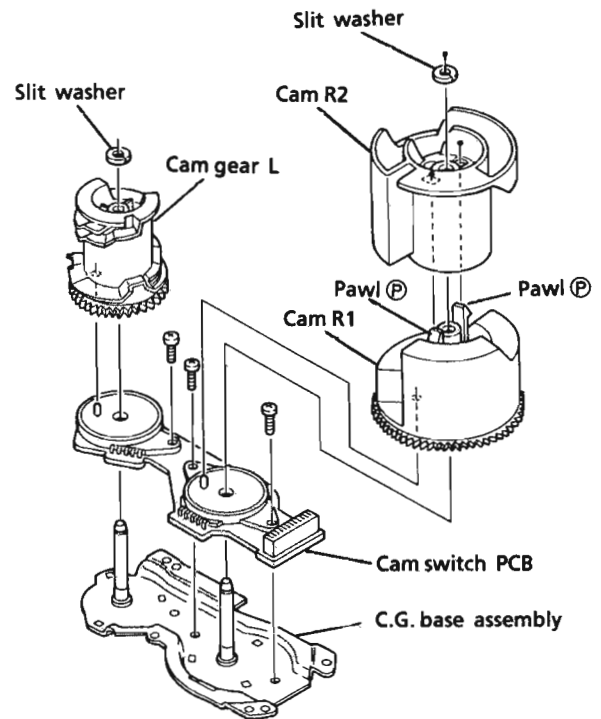

Fig. 41

(27) Removal of C.G base ass'y

Remove 3 screws ③ securing the C.G. base ass'y. (See Fig. 41 and 42.)

[NOTE] Set the drive unit's pawl ④ so that it is positioned as shown in Fig. 42.  
Confirm that the cam gear L engages with the gear unit by rotating the cam gear L.

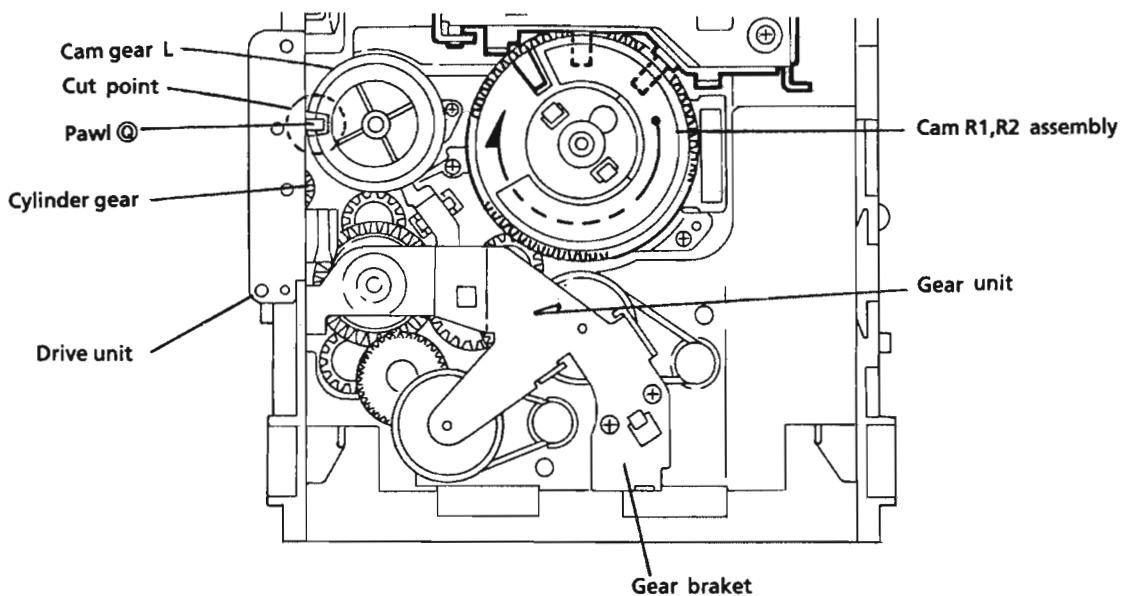

Fig. 42

④ .. SPST2606Z

- (28) Removing the Pickup  
 1. Remove the CD mech. assembly.  
 2. Release the shaft to remove the pickup .

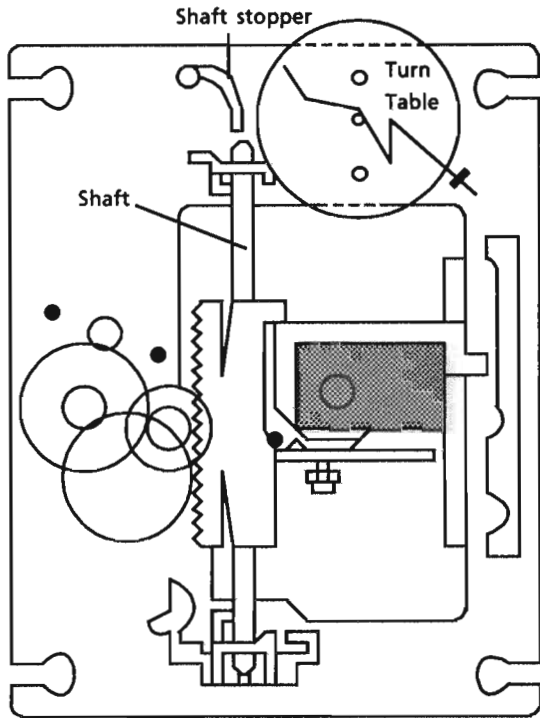

Fig. 43

- (29) Spindle motor installation  
 1. Tighten the 2 screws to the same torque.  
 2. Fasten the spindle and feed motor P.C. board with the screw and solder.  
 3. Install the turntable. When installing, press straight down at the center of the turntable until the distance from the surface of the mech. base to the turntable is exactly  $19.4 \pm 0.1\text{mm}$ .

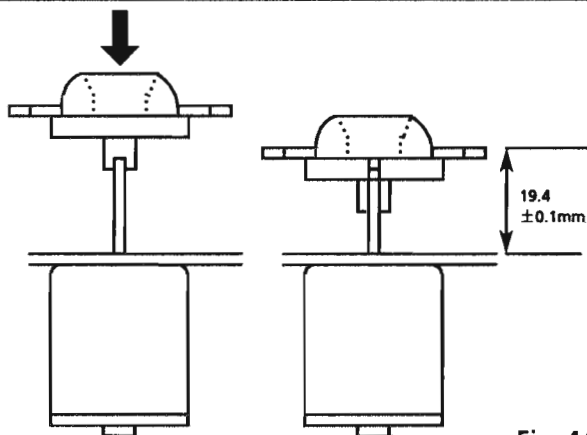

Fig. 44

- (30) Removing the Spindle motor  
 1. Remove the CD mech. assembly.  
 2. Remove the turntable, and remove the 2 screws ⊗ retaining the spindle motor.  
 3. Remove the screw retaining the spindle and feed motor circuit board and unsolder it.

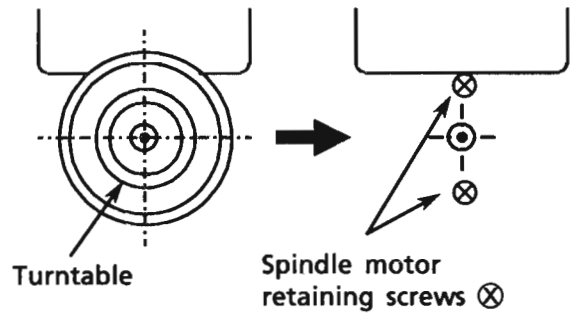

Fig. 45

- (31) After inserting the turntable, bond the motor shaft and turntable together (at the section marked by an arrow in fig 46 on the left below).

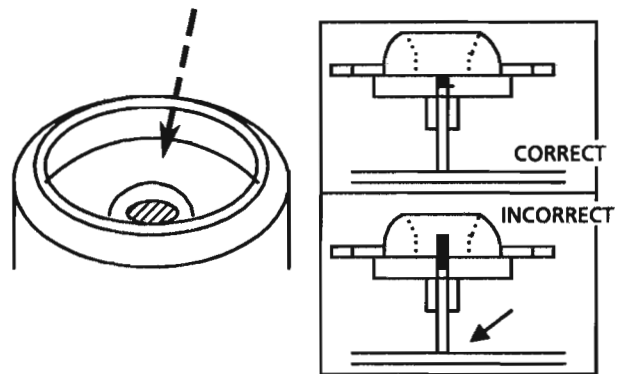

Fig. 46

- (32) Use "LOKTTITE" #460 bonding agent, and apply as little as possible .  
 Take care not to allow any excess bonding agent to get onto the turntable .  
 Be extremely careful not to allow bonding agent to adhere to the motor bearing (the section marked by an allow in fig 46 on the right).

⊗ .. SDSP2003N



**Adjustment procedures**

■ Tuner section

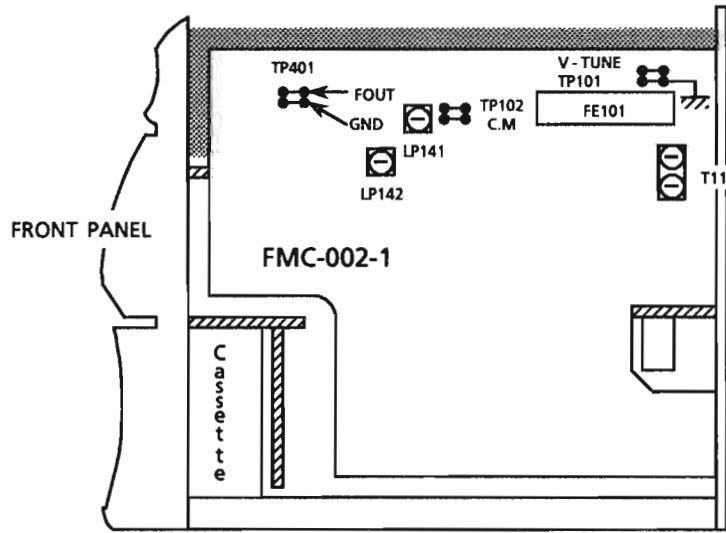
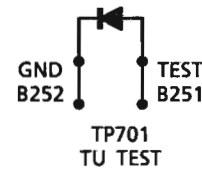

Fig.1

**Clock Adjustment**

1. After connecting B251 and B252 with some wire as shown in the figure below, connect the AC power cord into an AC outlet.
2. Confirm that the display is off and remove the wire.
3. Connect a frequency counter to TP401 B178 and B179.
4. Confirm the frequency  $50000 \pm 0.29\text{Hz}$ .



FMB-006-1(Front PCB)

(1) Tuning voltage

Confirm the voltages at TP101 is within the standard values shown in the table below. If the voltages are not satisfied, replace T111 for MW and for LW or FE101 for FM.

**FM Tuning voltage (Unit : V)**

Area	Frequency			
	64.0MHz	74.0MHz	87.5MHz	108MHz
East Europe	$1.8 \pm 1.0 (V)$	$1.8 \pm 1.0 (V)$	$9 \sim 10.5 (V)$	$9 \sim 10.5 (V)$
the U.K. , Continental Europe, U.S.A. , Canada, Australia, Universal	—	—	$1.6 \pm 1.0 (V)$	$8.0 \pm 2.0 (V)$

**AM Tuning voltage (Unit : V)**

Area	Frequency (MW)							Frequency (LW)	
	522KHz	530KHz	531KHz	1600KHz	1602KHz	1629KHz	1710KHz	144kHz	288kHz
BS,EF,EN,G,GI,VX	>0.7	—	—	—	—	<8.3	—	0.5<	>7.5
C,J	—	>0.8	—	—	—	—	<8.8	—	—
U,UT,UB,UP,US(Channel Space 9kHz)	—	—	>0.8	—	<7.9	—	—	—	—
Universal(Channel Space 10kHz)	—	>0.8	—	<7.9	—	—	—	—	—
A	>0.7	—	—	—	—	<8.3	—	—	—

(2) FM center meter

Receive a broadcast which understanding the frequency by using the function of 'MANUAL SEARCH'. Adjust T105 (detector coil) so that the voltage at TP102 becomes  $0 \pm 1.5\text{mV}$ .

**The Marks for Designated Areas**

J ..... the U.S.A.	A ..... Australia	C ..... Canada	VX ..... East Europe
G ..... Germany	U ..... Universal	US ..... Singapore	UT ..... Taiwan
EF ..... Continental Europe	EN ..... Scandinavia	GI ..... Italy	BS ..... the U.K.
UB ..... Hong Kong	UP ..... Korea	No mark indicates all area.	

■ Deck Adjust point

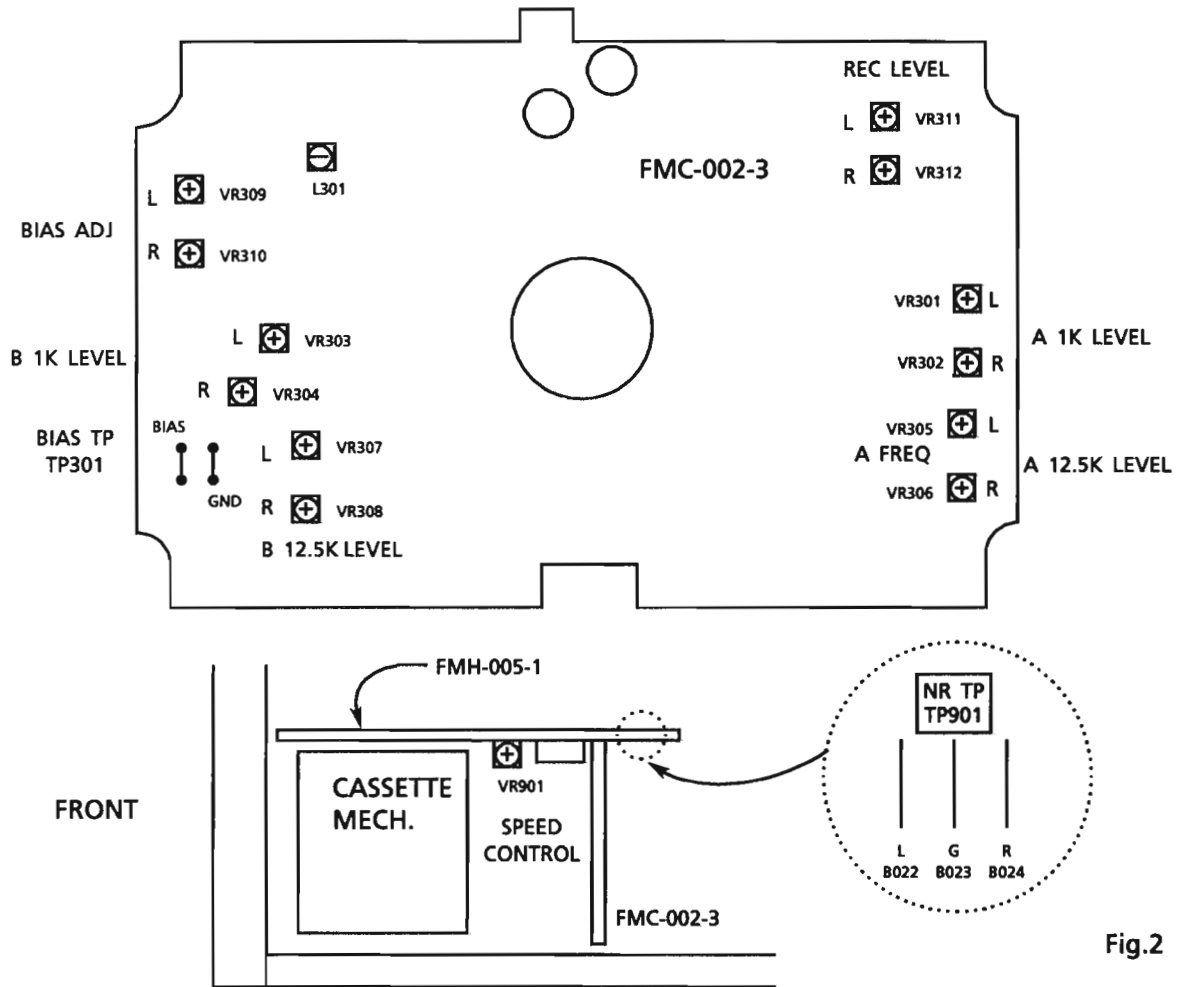

Fig.2

Deck section

1. Measuring instruments

- Audio frequency signal generator ( 0dbs output at the 600 ohm output terminal from 50Hz to 20KHz)
- Electronic voltmeter
- Frequency counter
- Wow & Flutter meter
- Distortion Meter with band pass filter
- Attenuator (600 ohm impedance)
- A resistor with 600Ω

Tape No.	Frequency	Level (Wow & Flutter)	Purpose
VTT-703L	10kHz	- 10dBs	Head azimuth , Frequency Response
VTT-712	3000Hz	0dBs 0.025%WRMS	Tape Speed , Wow & Flutter
VTT-724	1kHz	- 4dBs	Standard Level
TMT-6447	--	--	Blank Skip
TMT-6247 , TMT-6237	--	--	Music Scan
TMT-7088S	--	--	Recording standard Normal : UR
AC-712	--	--	Recording standard METAL :MA
AC-513	--	--	Recording standard CrO <sub>2</sub> ,SA
TW-2111, TW-2121	--	--	Forward / reverse play torque measuring
TW-2231	--	--	Feed forward / rewind torque measuring
C-120 Tape	--	--	Confirming the tape running

## Adjustment and repairing the mechanism

Item	Adjustment method	Standard value	Remarks
Head azimuth	<p>Deck A</p> <ol style="list-style-type: none"> <li>1. Connect an electronic voltmeter to the NR TP901 (figure 1) to playback VTT-703L.</li> <li>2. Adjust screw (A) so that the indication of the voltmeter becomes maximum when PLAY (▶) is pressed.</li> <li>3. Adjust screw (B) so that the indication of the voltmeter becomes maximum when PLAY (◀) is pressed.</li> </ol> <p>Deck B</p> <ol style="list-style-type: none"> <li>4. Adjust screw (C) so that the indication of the voltmeter becomes maximum when PLAY (▶) is pressed.</li> <li>5. Adjust screw (D) so that the indication of the voltmeter becomes maximum when PLAY (◀) is pressed.</li> <li>6. After making the adjustment, apply screw lock to prevent screws (A), (B), (C) and (D) coming loose.</li> </ol>	Maximum	<ol style="list-style-type: none"> <li>1. Refer to figure 3.</li> <li>2. When the specified characteristic cannot be obtained because of head wear, excessive magnetization, etc., replace the head assembly and adjust the head azimuth. Also, perform the electric adjustment.</li> <li>3. When there is the difference of more than 3 ~ 4 dB between left and right output levels, replace the head assembly to avoid complaints.</li> </ol>
Playback torque	1. Measure the torque in the playback mode by the torque meter.	26 ~ 72 g-cm	When the standard torque cannot be obtained, replace the FR arm assembly or motor.
Fast forward torque	1. Measure the torque in the fast forward mode by the torque meter.	75 ~ 175 g-cm	When the standard torque cannot be obtained, replace the FR arm assembly or motor.
Rewind torque	1. Measure the torque in the rewind mode by the torque meter.	75 ~ 175 g-cm	When the standard torque cannot be obtained, replace the FR arm assembly or motor.
Wow & flutter	<ol style="list-style-type: none"> <li>1. Connect the wow &amp; flutter meter to the DOLBY TP (figure 1) and play back VTT-712.</li> <li>2. Its reading should be within 0.25% (WTD).</li> </ol>	Less than 0.25%	As a complaint may occur if the wow & flutter fluctuates by 0.1% even though it is allowed in the standard, repairing is required.

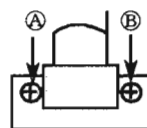

Deck A

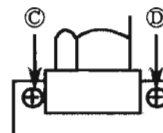

Deck B

Fig.3

### 3. Electrical Adjustments (Make the following adjustments after adjusting the head azimuth.)

In principle, the adjustments should be made in the following sequence.  
 Set the NR switch to OFF and the BEAT CUT switch to "1".  
 Adjustments marked with an asterisk (\*) should always be made after the head is replaced

0dBs=0.775V

Item	Adjustment Method	Adjustment Location	Standard Value	Remarks
Tape Speed	1. Connect a frequency counter to the NR TP 901 (figure 1) and play back VTT-712 . 2. Adjust the semi-fixed resistor VR901 on FMH-005 - 1 (figure 1).	VR901	3,000 Hz ±10Hz	Connect a wow & flutter meter with a built-in frequency counter to the speaker terminals.
Standard level (Playback Level)	1. Connect an electronic voltmeter to the NR TP901(figure 1) . Play back VTT-724 (1 kHz : -4dBs) to adjust the semi - fixed resistors.	<b>Deck A</b> L: VR301 R: VR302 <b>Deck B</b> L: VR303 R: VR304	488mV (-4dBs)	1) The playback level varies when the head is replaced so should be adjusted. Use an electronic voltmeter with an impedance of 100 kΩ or more.
Playback Frequency Response	1. Connect an electronic voltmeter to the NR TP 901(figure 1) . 2. Play VTT-703L (10kHz : -10dBs) and adjust semi-fixed resistors to obtain the standard values.	<b>Deck A</b> L: VR305 R: VR306 <b>Deck B</b> L: VR307 R: VR308	245mV (-10dBs)	—
Recording Bias Frequency	1. Connect a frequency counter to the BIAS TP(figure 1) , and perform a recording to adjust bias frequency .	L301	105 kHz ±5 kHz	Set the BEAT CUT SWITCH to "1" . (BS,EF,EN,G,GI,VX only)
Record / Play Frequency Response (Bias current)	1. Supply 1kHz and 12.5kHz with 30mV signals to AUX terminals respectively to record them. 2. Connect an electronic voltmeter to the NR TP901 (figure 1) to confirm the recorded values. 3. If the values are not satisfied , adjust the semi-fixed resistors and record the signal again to confirm the recorded values.	L : VR309 R : VR310	0±2 dB with 1 kHz as the standard.	<b>Refer to figure 4 below.</b> 1) The recording and playback frequency response of a cassette deck are adjusted by adjusting the bias. 2) Perform the adjustment with normal tape and confirm that the values are within the range for metal tape.

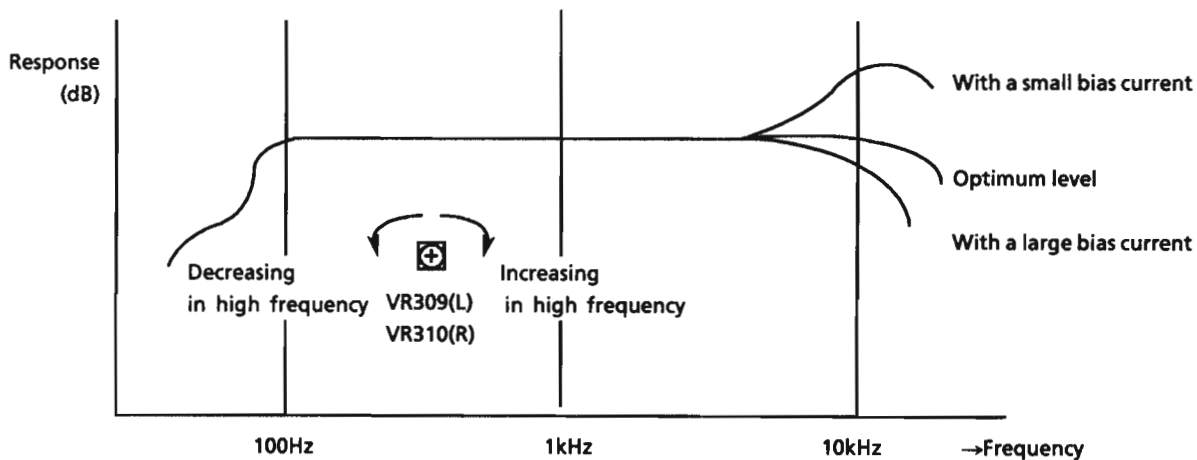
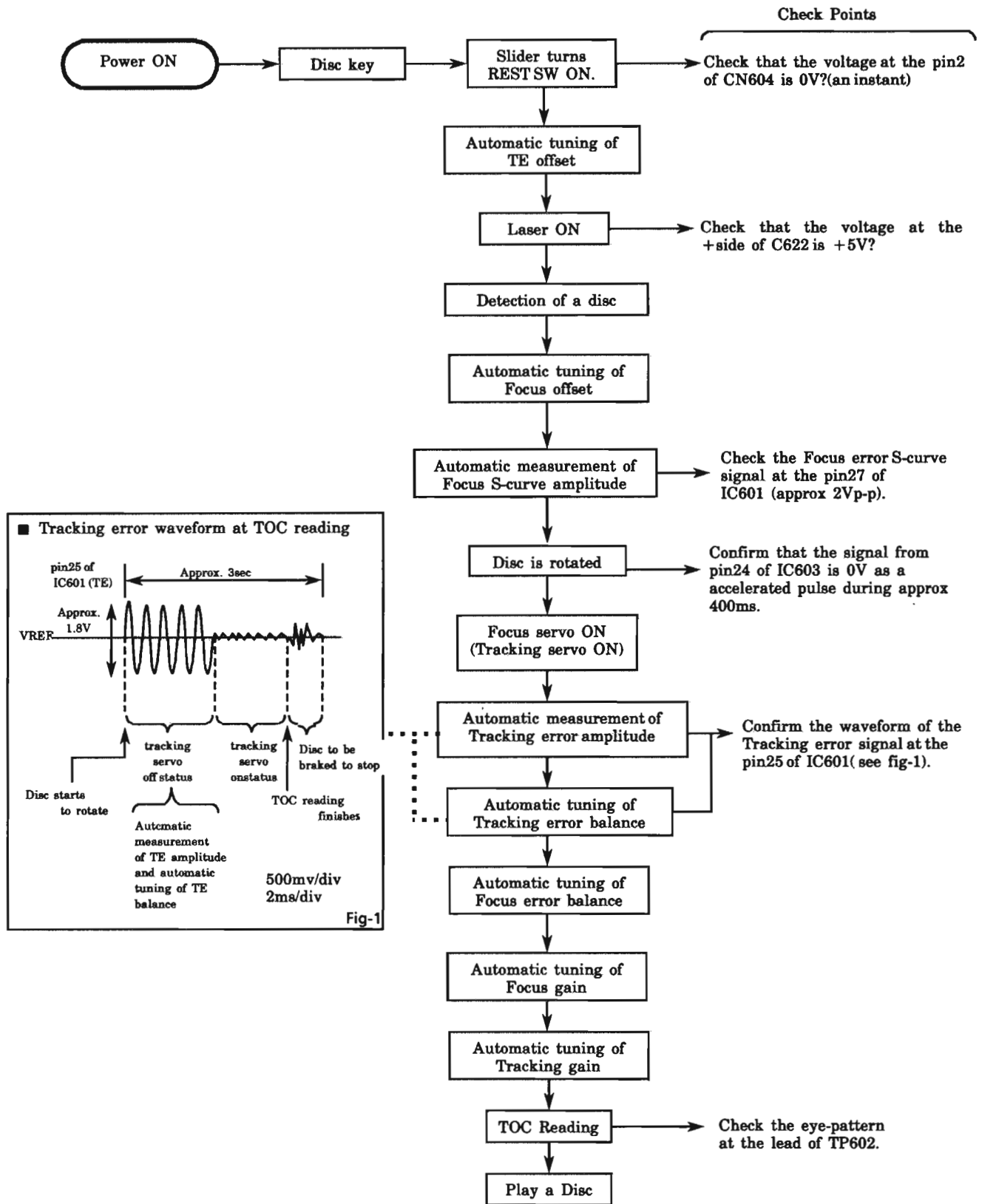

Fig.4

# Flow of Functional Operation Until TOC is Read



## Maintenance of Laser Pickup

### (1) Cleaning the pick up lens

Before you replace the pick up, please try to clean the lens with a alcohol soaked cotton swab.

### (2) Life of the laser diode (Fig.1)

When the life of the laser diode has expired, the following symptoms will appear.

The level of RF output (EFM output: amplitude of eye pattern) will be low.

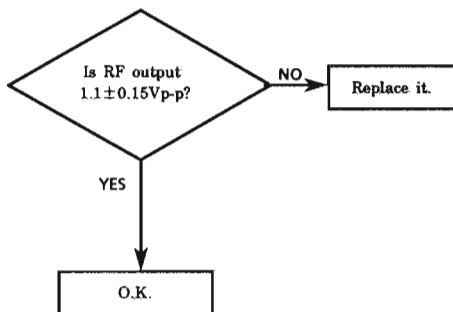

### (3) Semi-fixed resistor on the APC PC board

The semi-fixed resistor on the APC printed circuit board which is attached to the pickup is used to adjust the laser power. Since this adjustment should be performed to match the characteristics of the whole optical block, do not touch the semi-fixed resistor.

If the laser power is lower than the specified value, the laser diode is almost worn out, and the laser pickup should be replaced.

If the semi-fixed resistor is adjusted while the pickup is functioning normally, the laser pickup may be damaged due to excessive current.

## Replacement of Laser Pickup

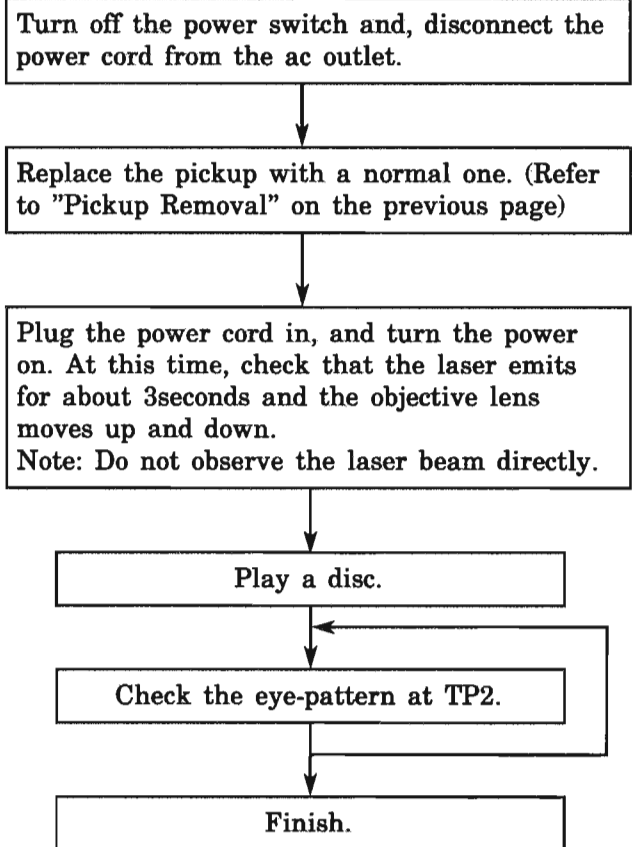



# Block Diagram

## TUNER, SOURCE SELECT & SEA SECTION

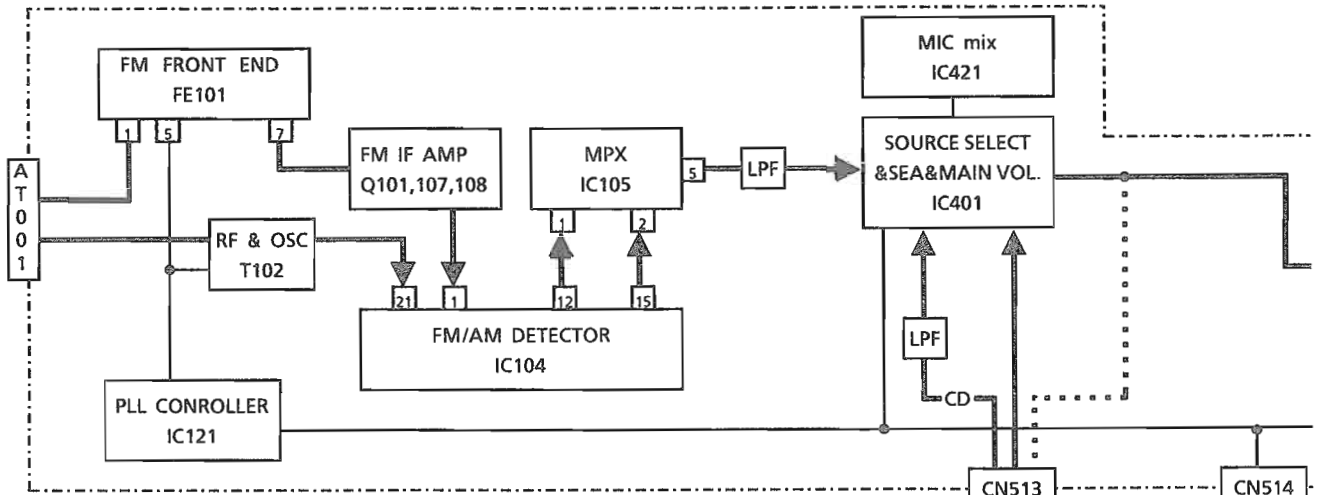

## CASSETTE DECK SECTION

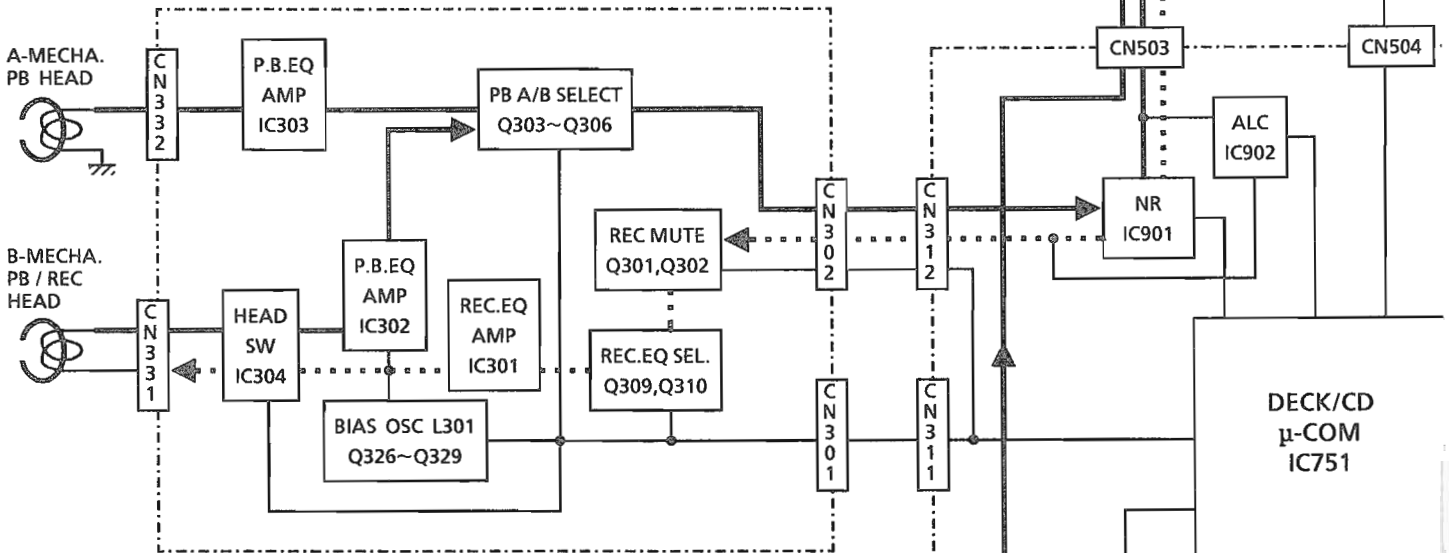

## CD SERVO SECTION

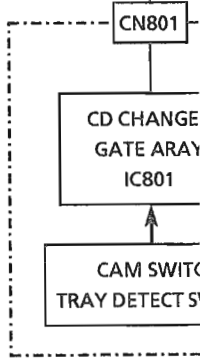
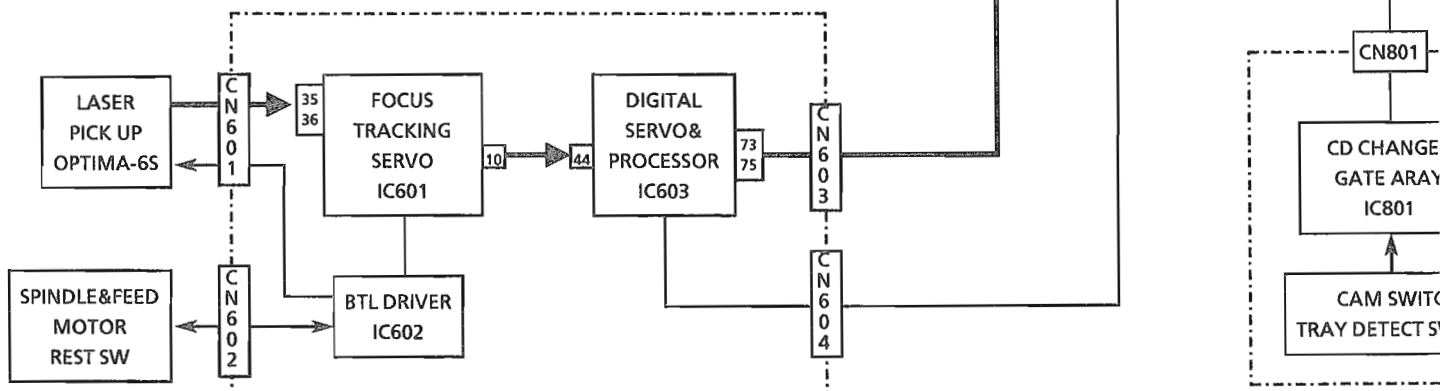



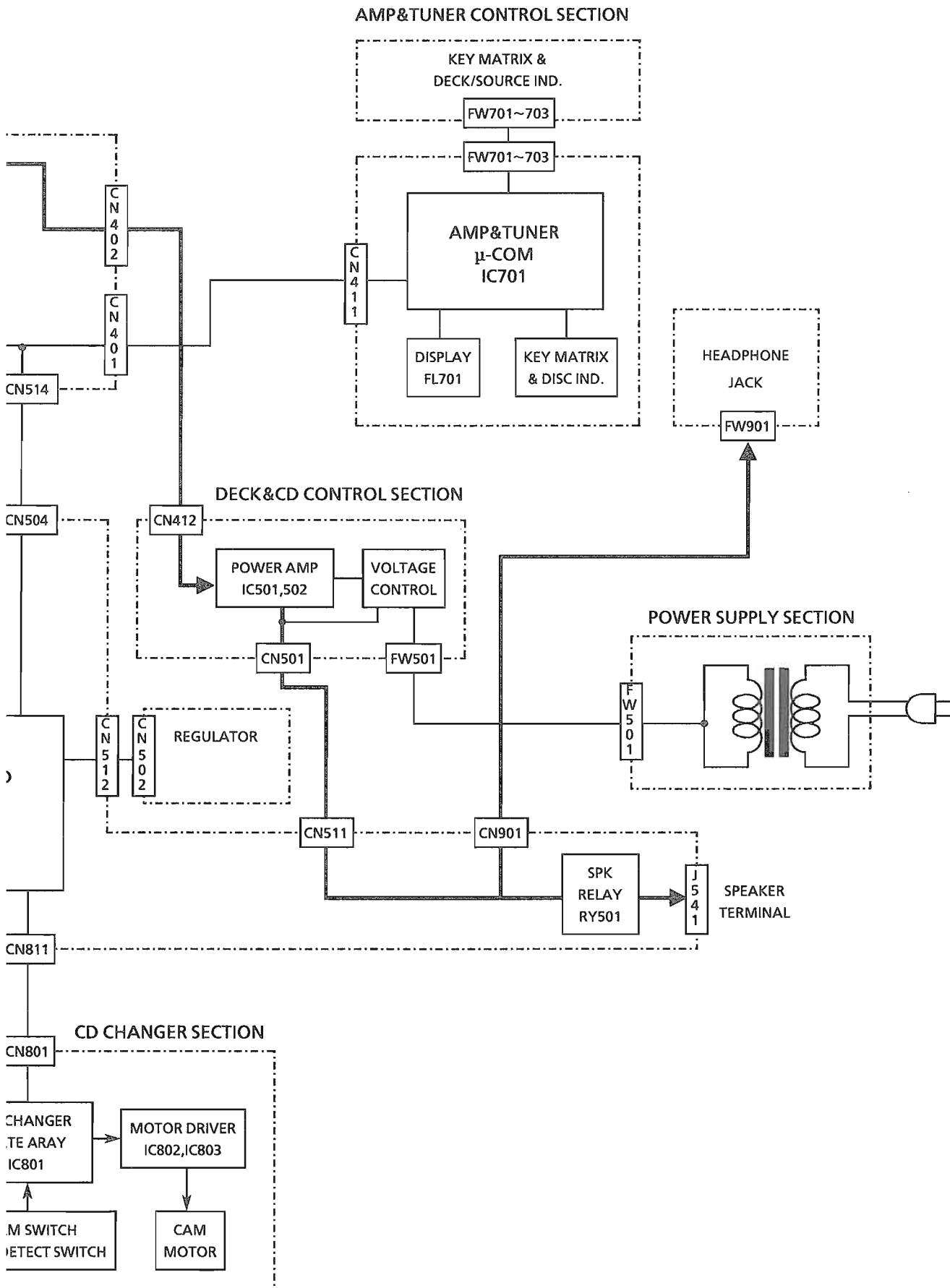



P1-57-a

P1-57-b

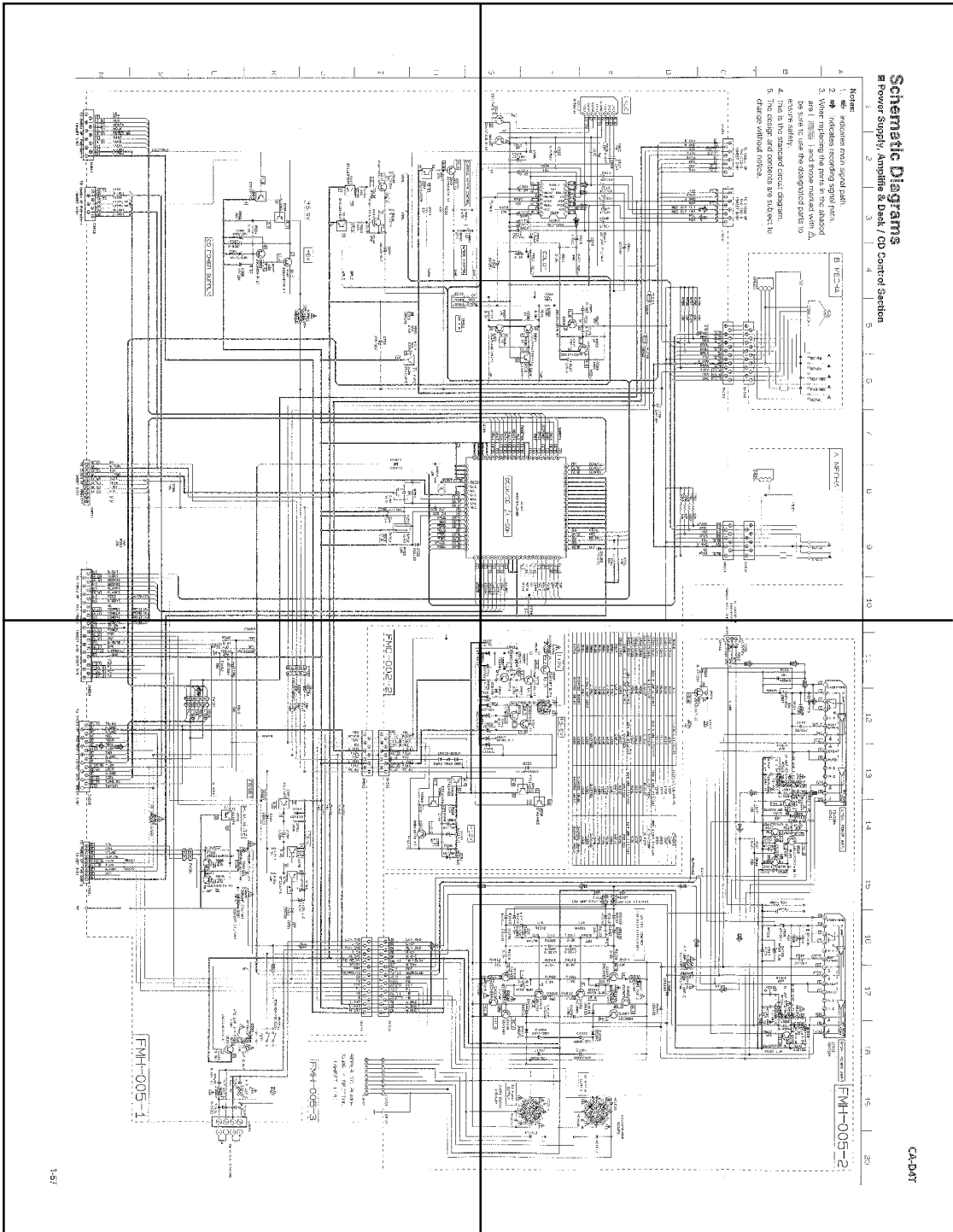

P1-57-c

P1-57-d

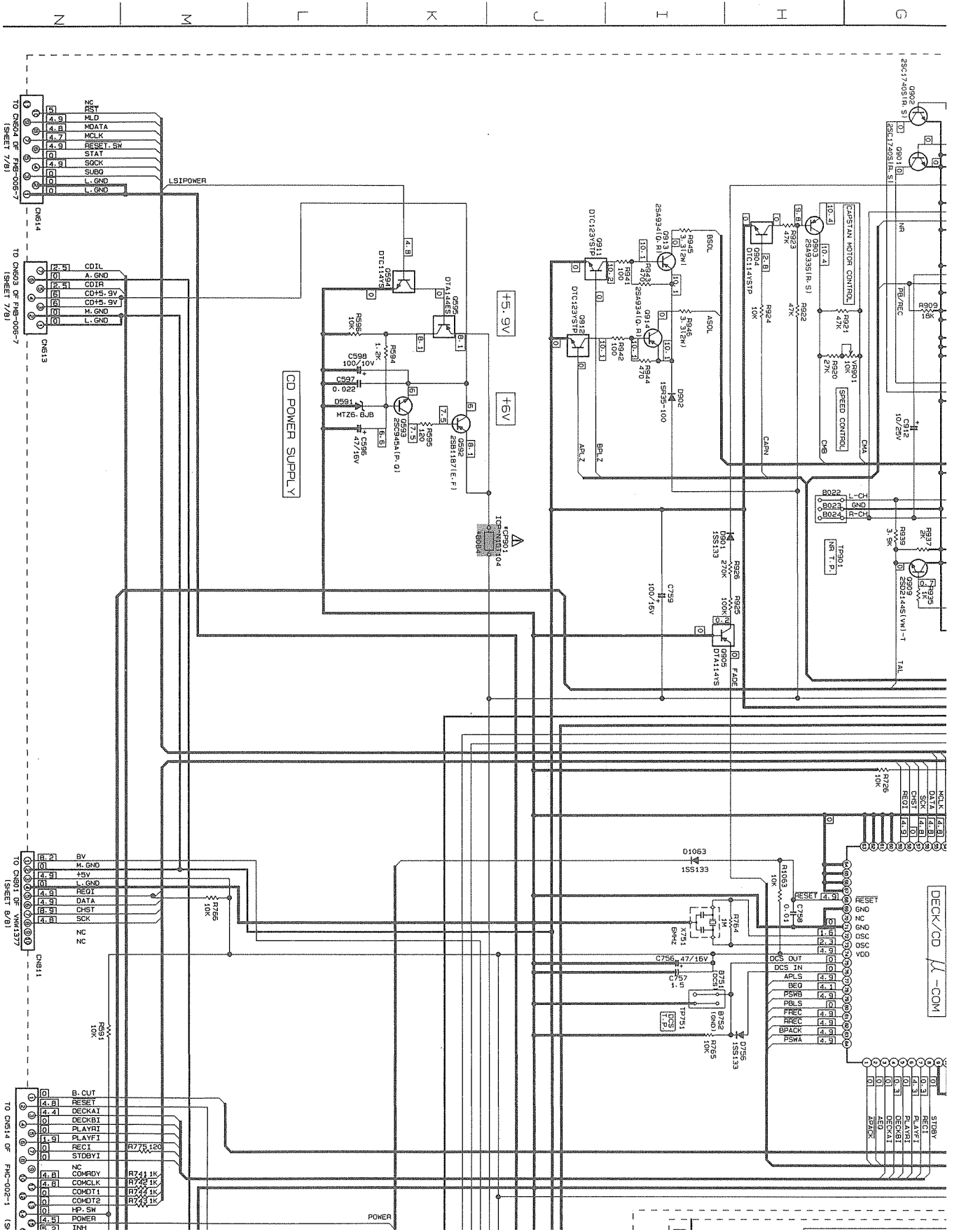

# Schematic Diagrams

## Power Supply, Amplifier & Deck / CD Control Section

1 2 3 4 5 6 7 8 9 10

### Notes:

1. indicates main signal path.
2. indicates recording signal path.
3. When replacing the parts in the shaded area ( ) and those marked with  $\Delta$ , be sure to use the designated parts to ensure safety.
4. This is the standard circuit diagram.
5. The design and contents are subject to change without notice.

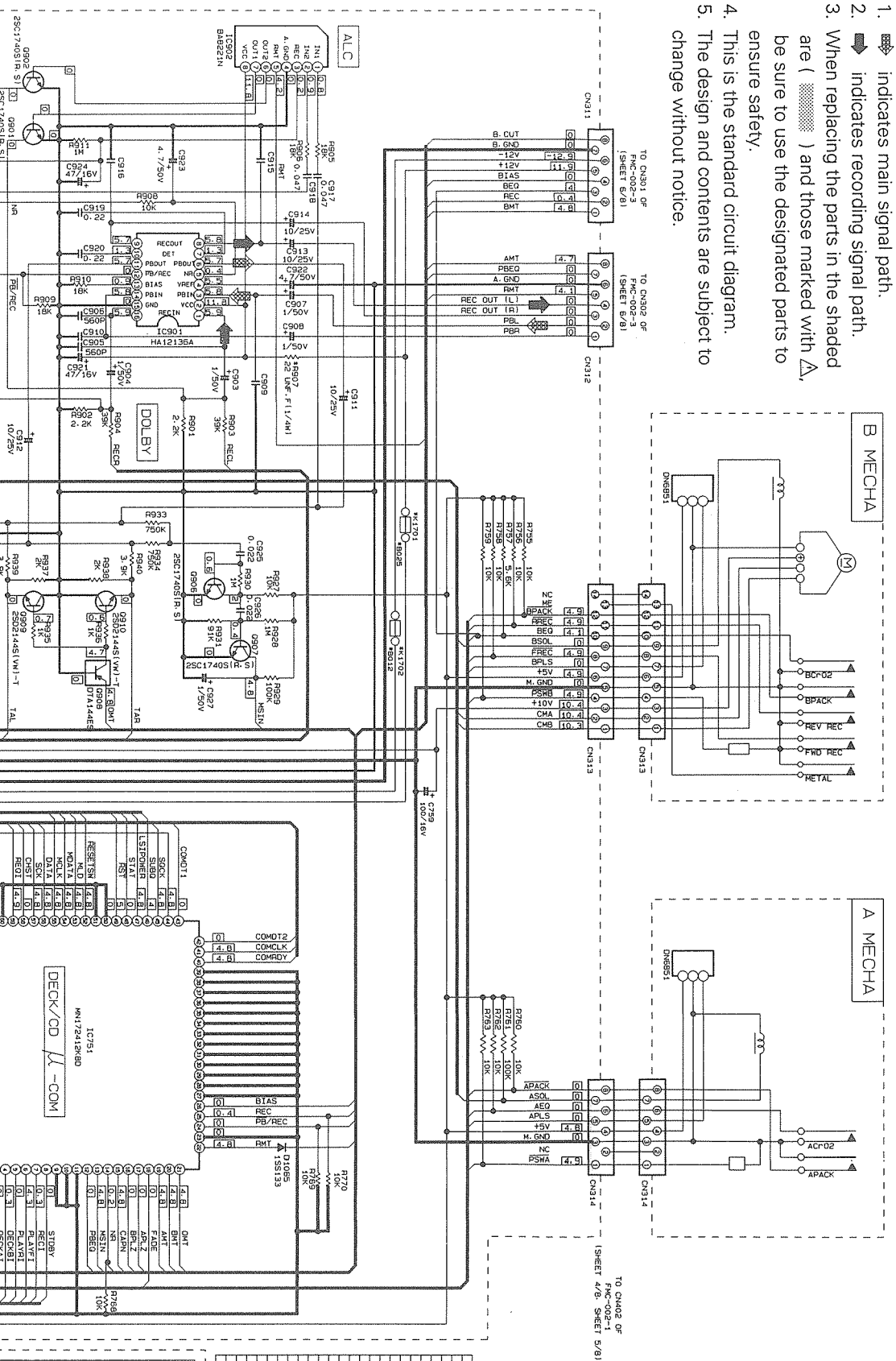

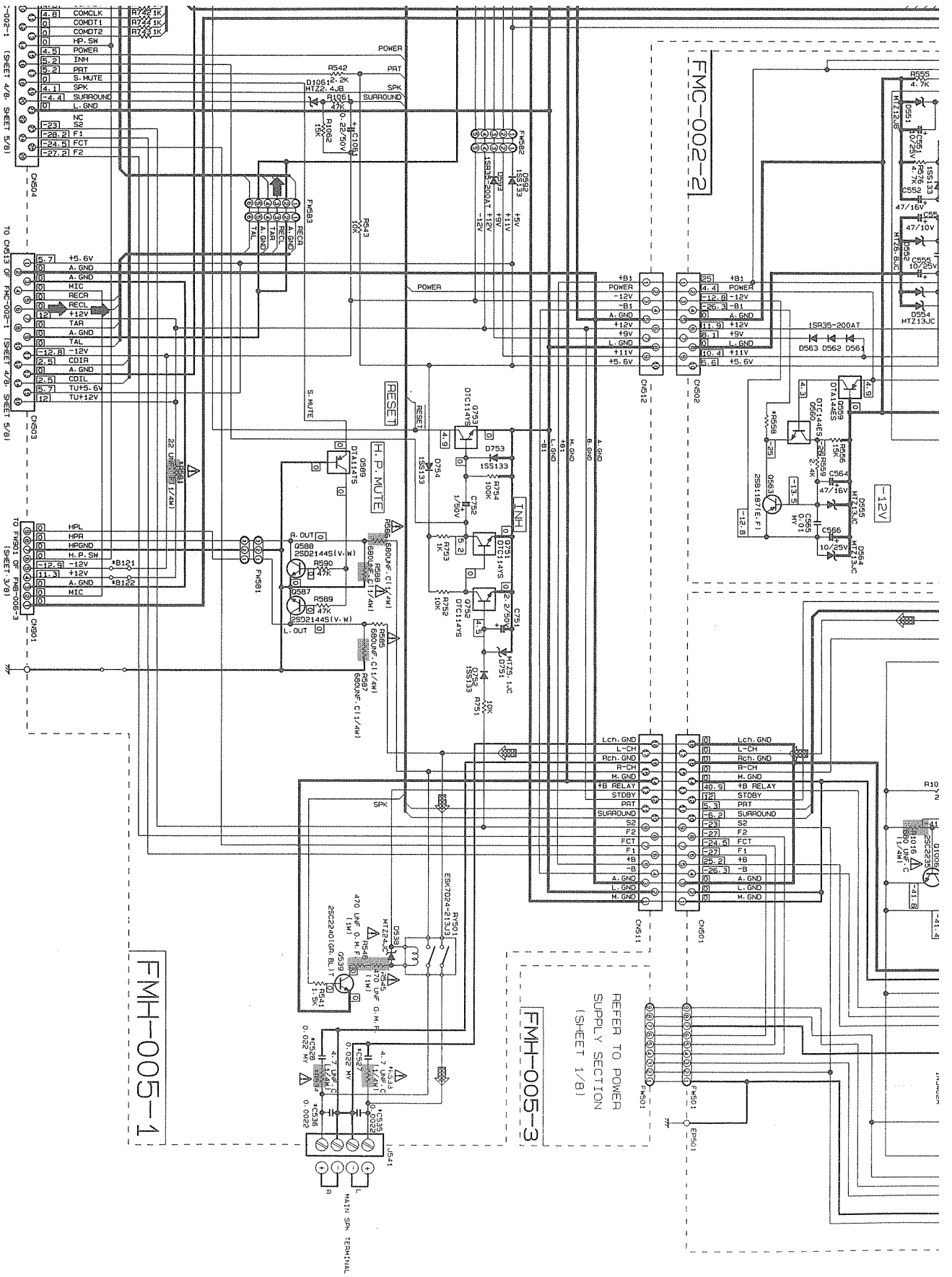

FMC-002-2

FMC-005-3

FMH-005-1

REFER TO POWER SUPPLY SECTION (SHEET 1/8)

TO CN513 OF FMC-002-1 (SHEET 4/8)

TO CN513 OF FMC-002-1 (SHEET 4/8)

TO FMS01 OF FMS-005-3 (SHEET 3/8)

77

11 | 12 | 13 | 14 | 15 | 16 | 17 | 18 | 19 | 20

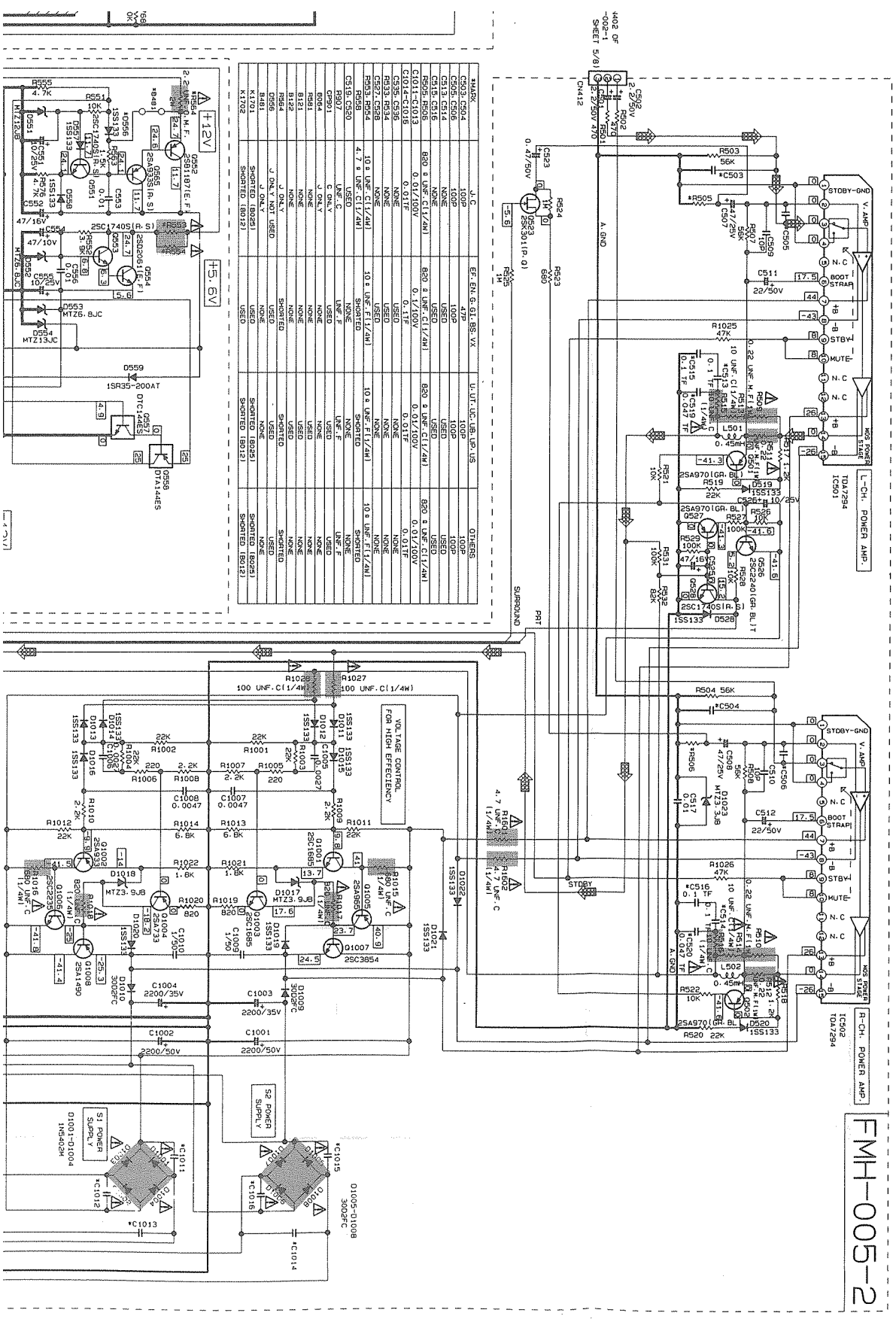

FMH-005-2

4211

4208  
SHEET 5/8





P1-58-a

P1-58-b

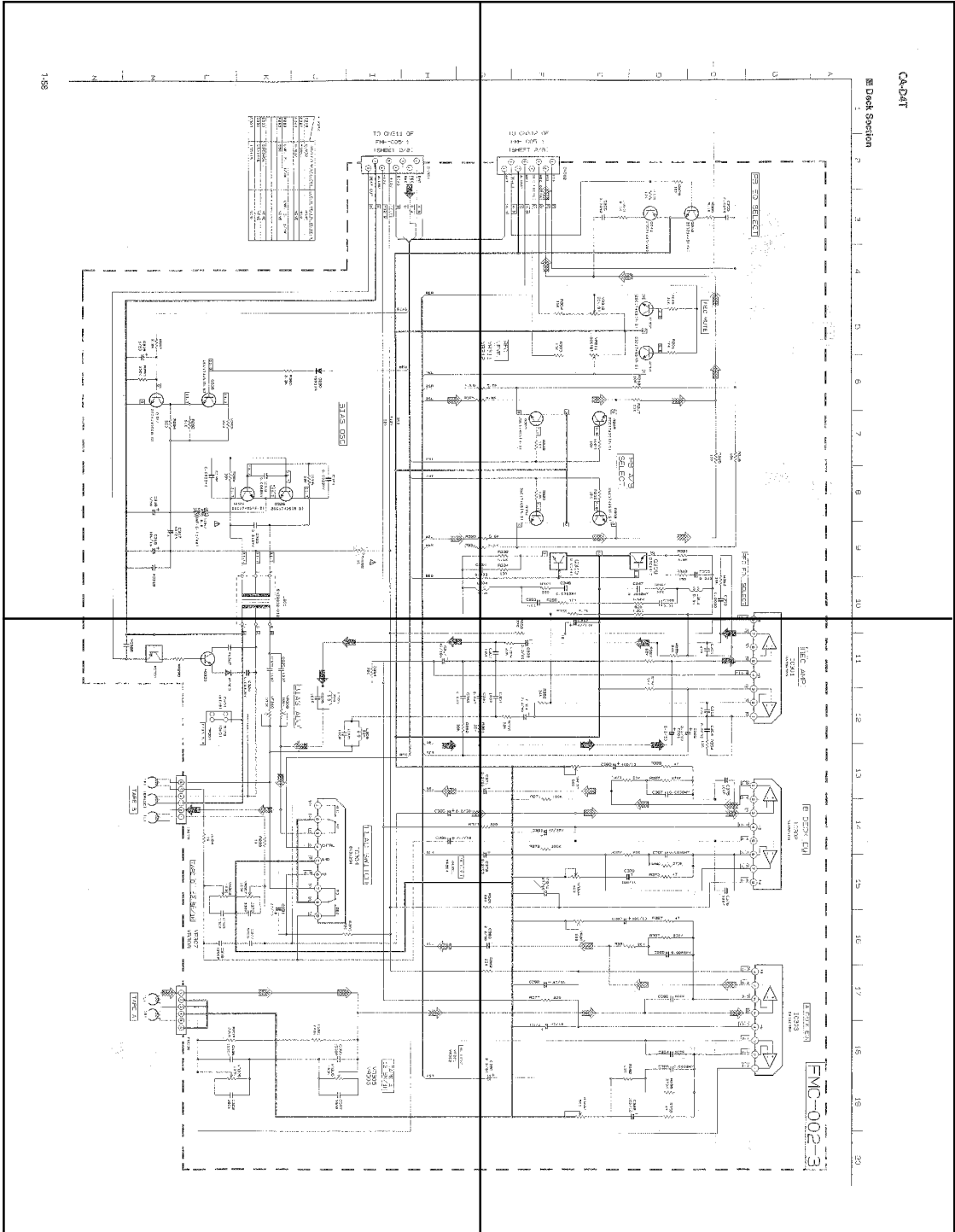

P1-58-c

P1-58-d

TO CN311 OF  
FMH-005-1  
(SHEET 2/8)

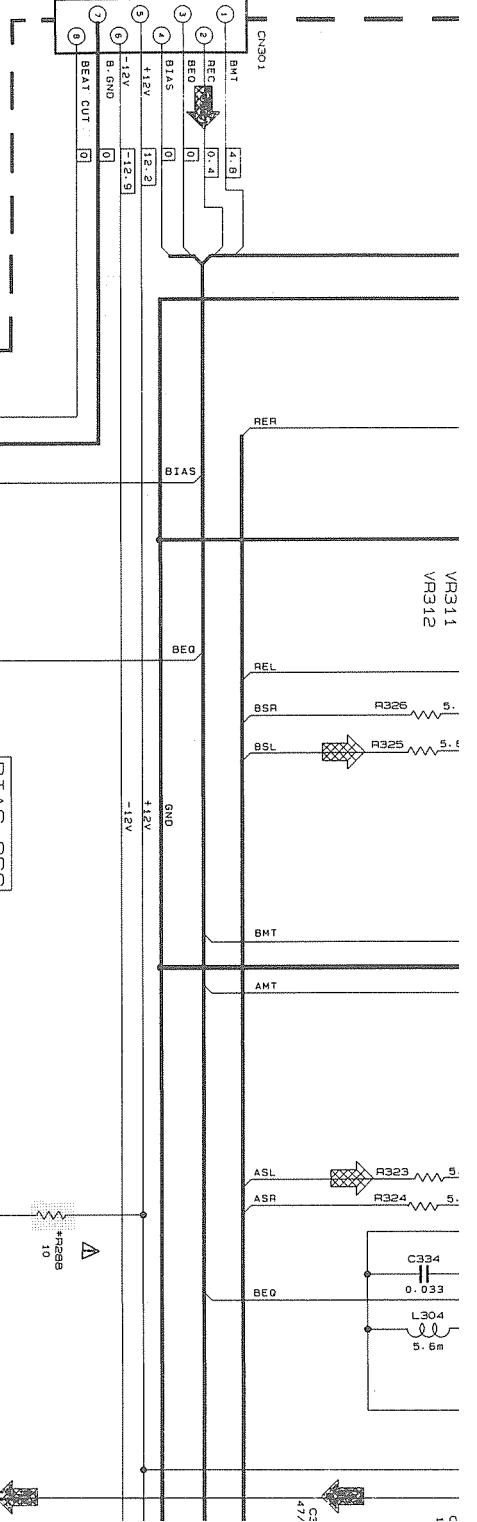

\* MARK

	85/EF/EN/6/61/VX	J. C. U. UB. UP. US. UT. A
C319	0.022	NONE
C327	5600	NONE
C328	0.022	NONE
R228	UNF. F. 1/4W	UNF. C. 1/4W
R229	560	NONE
Q330	2SC945A	NONE
Q331	DT144E	NONE
Q303	1S5119	NONE

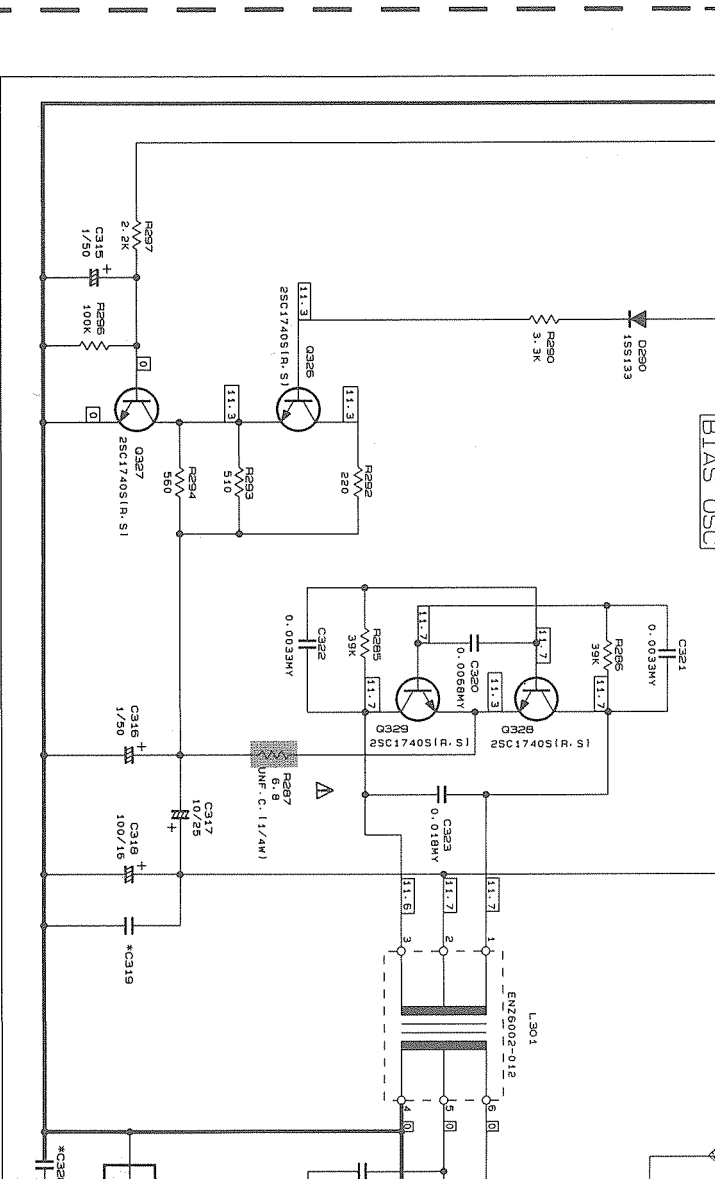

Deck Section

1 2 3 4 5 6 7 8 9 10

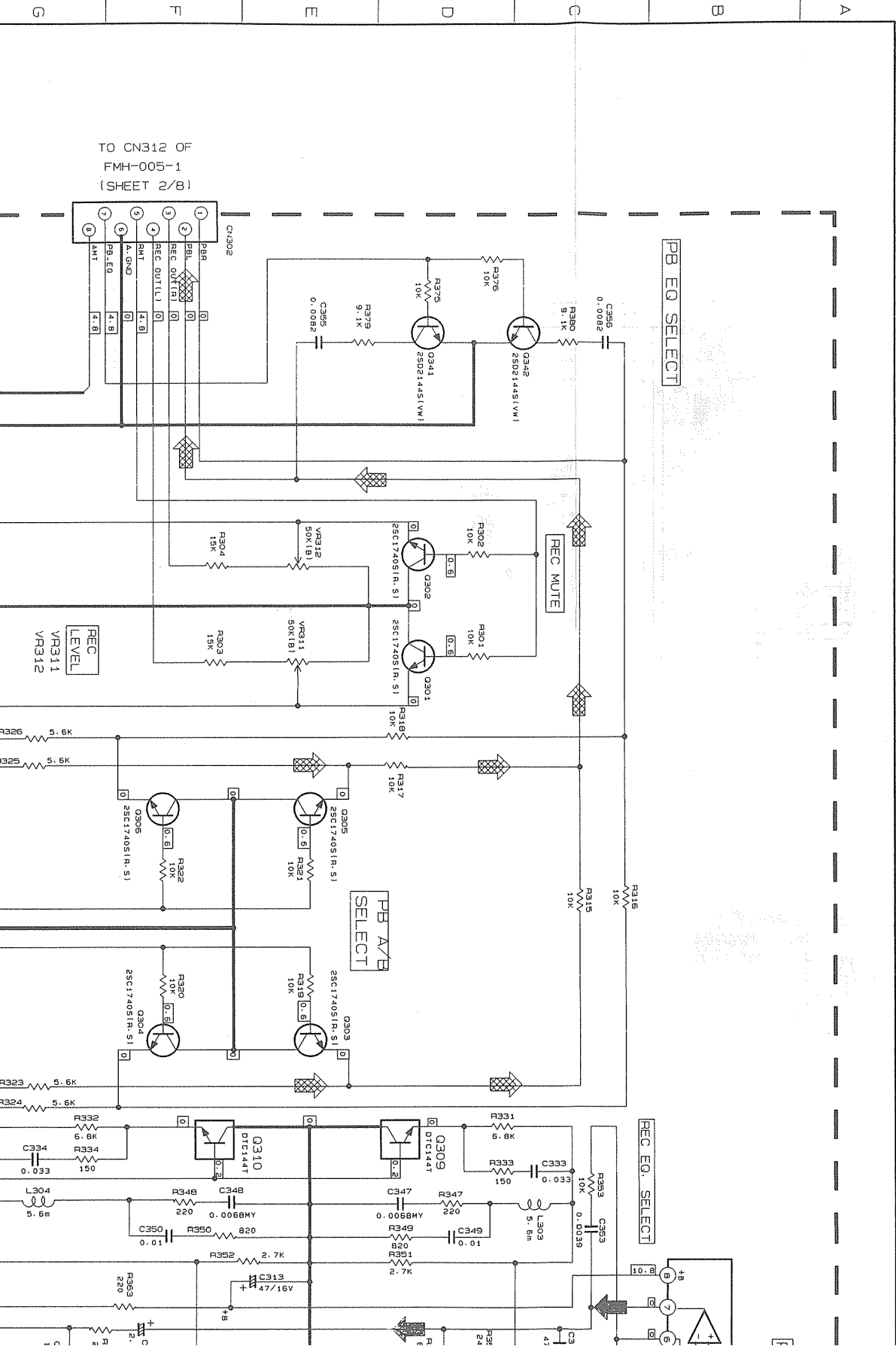

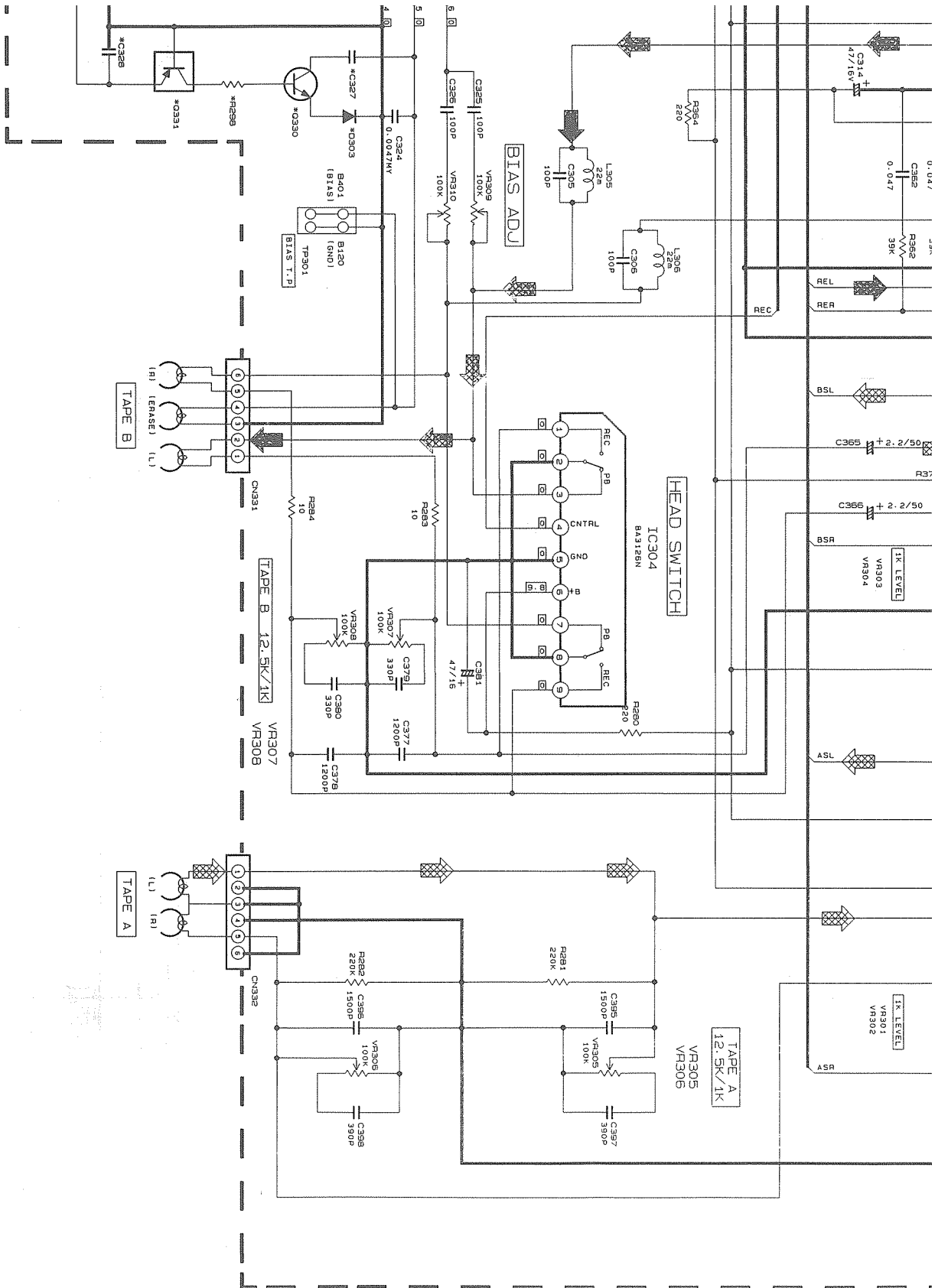

REC AMP

IC301  
BA1521BN

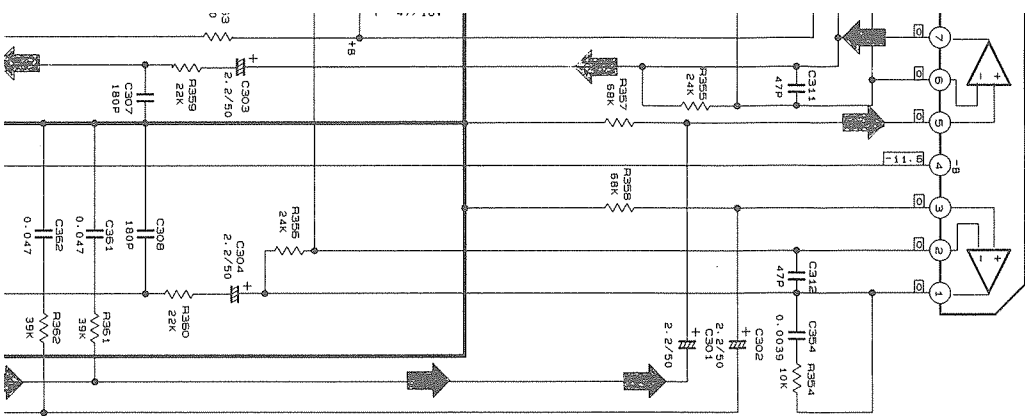

B DECK EQ

IC302  
BA1521BN

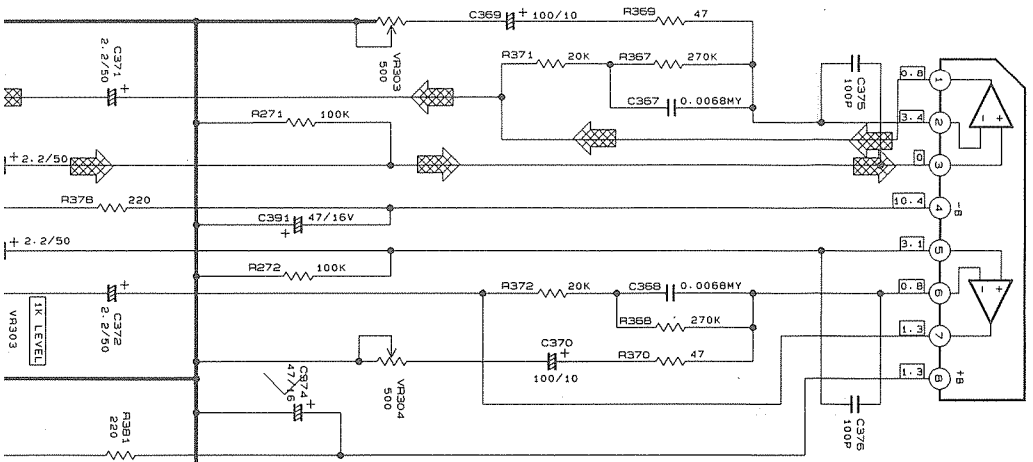

A DECK EQ

IC303  
BA1521BN

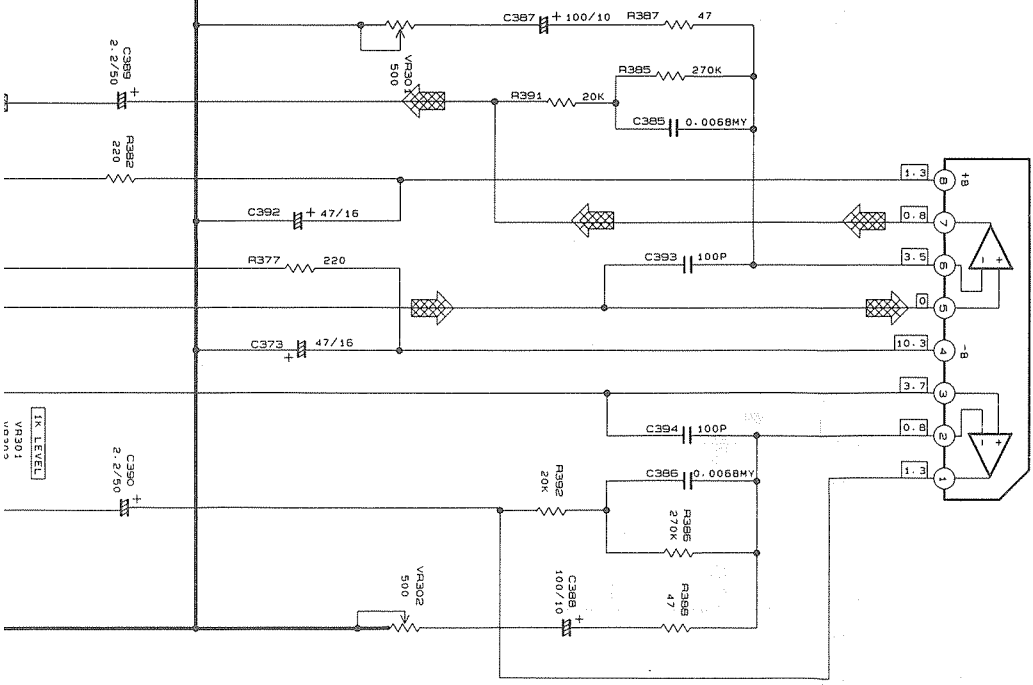

FMC-002-3



P1-59-a

P1-59-b

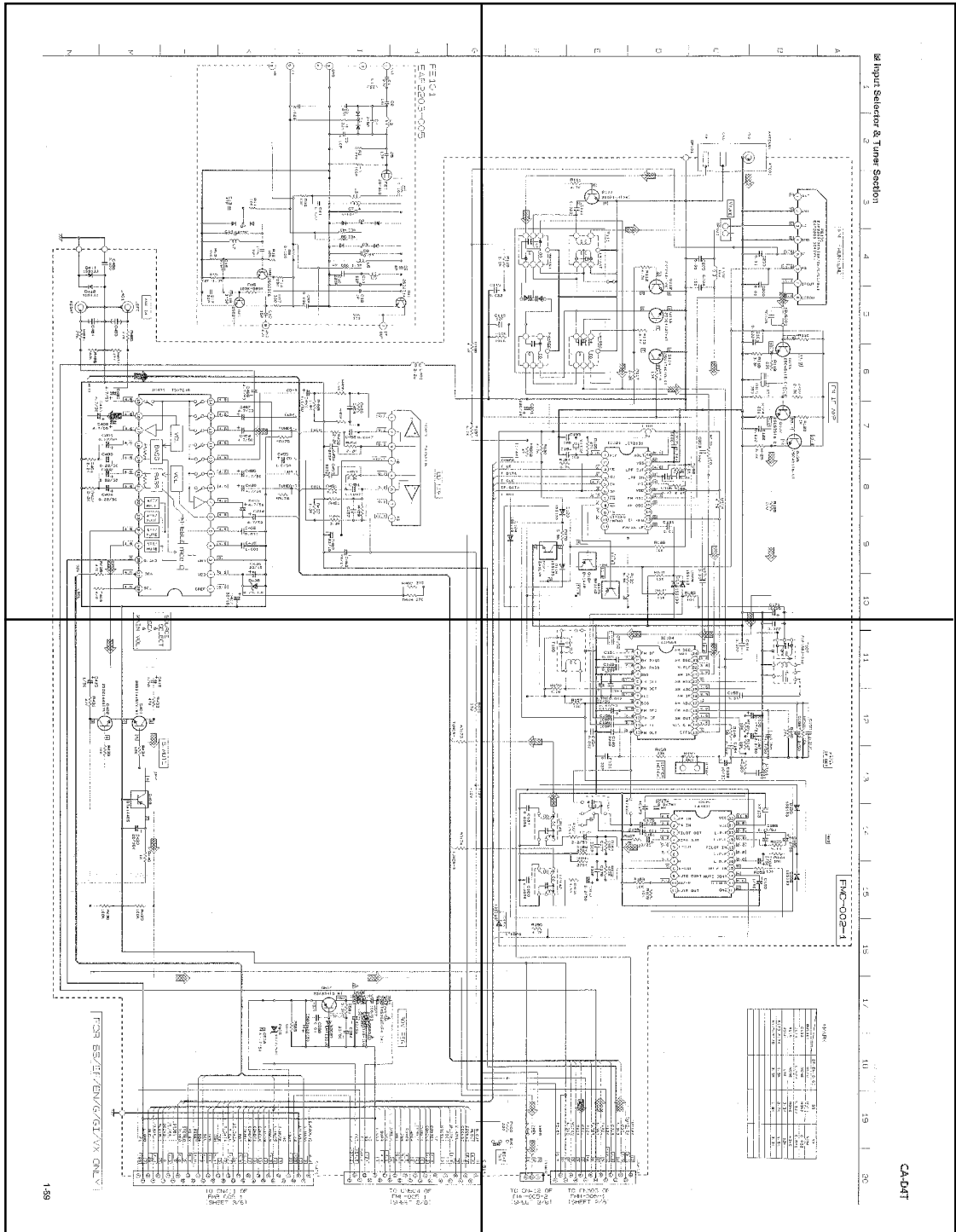

P1-59-c

P1-59-d

FE101  
EAF2203-005

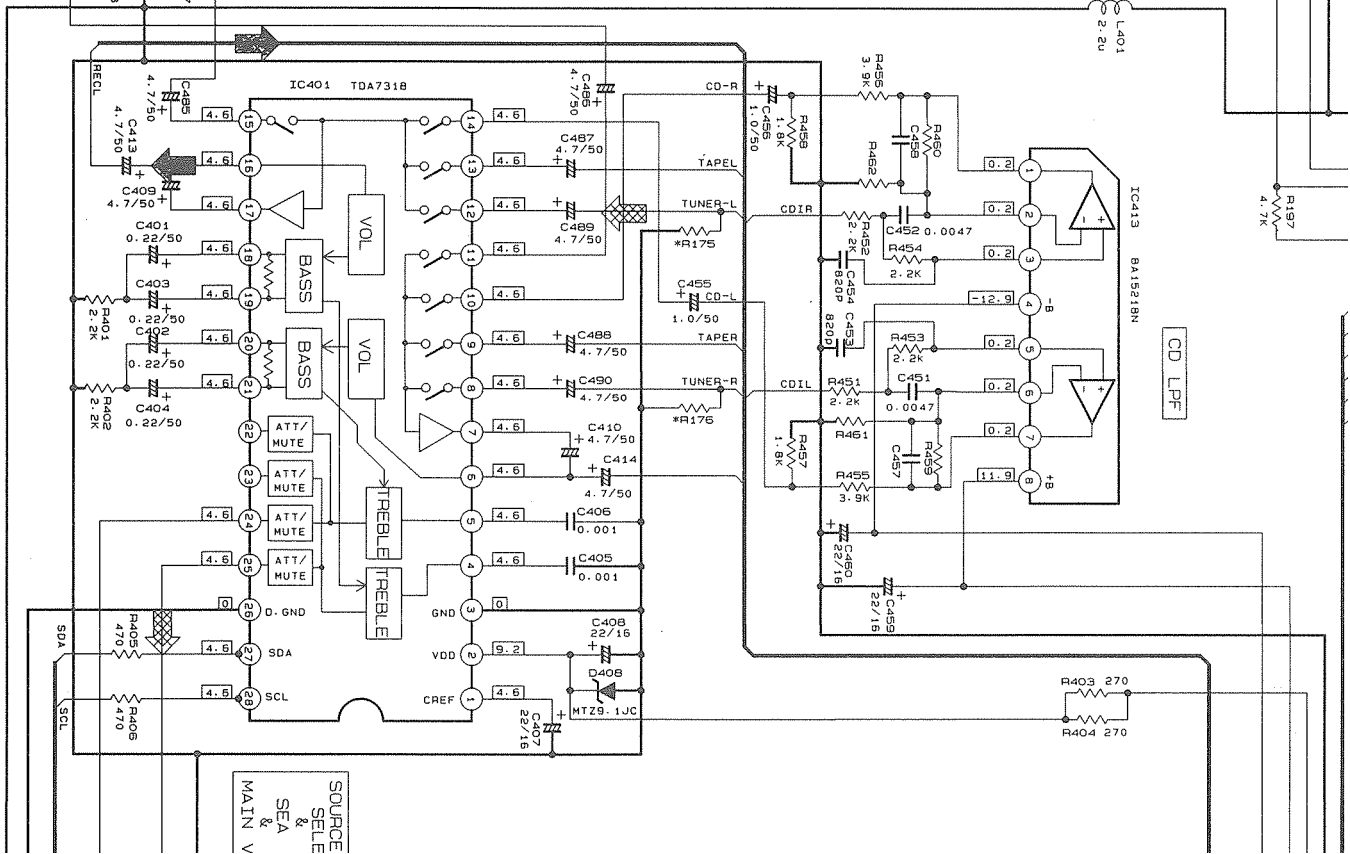
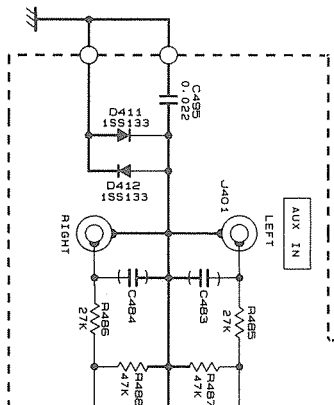
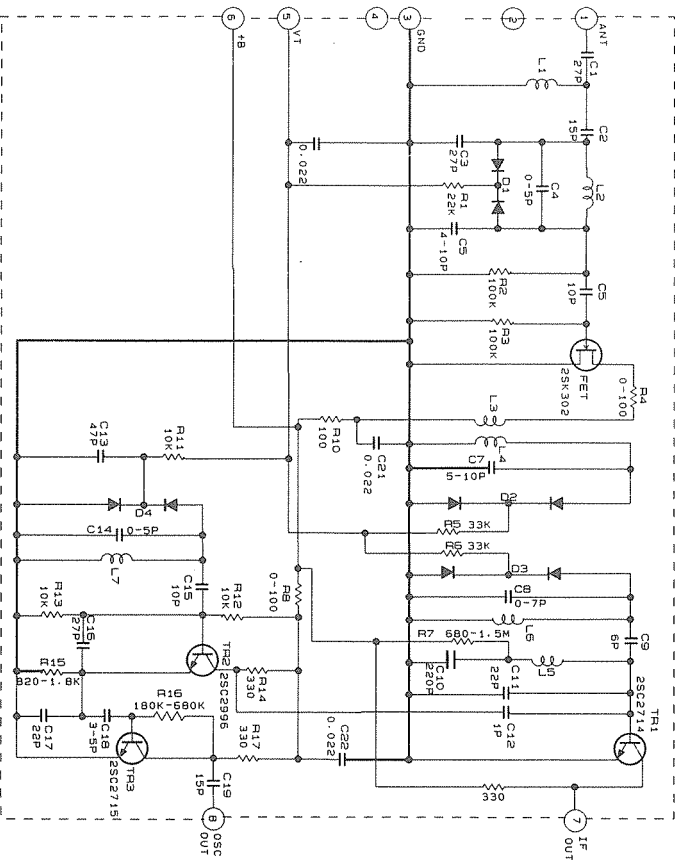



# Input Selector & Tuner Section

1 2 3 4 5 6 7 8 9 10

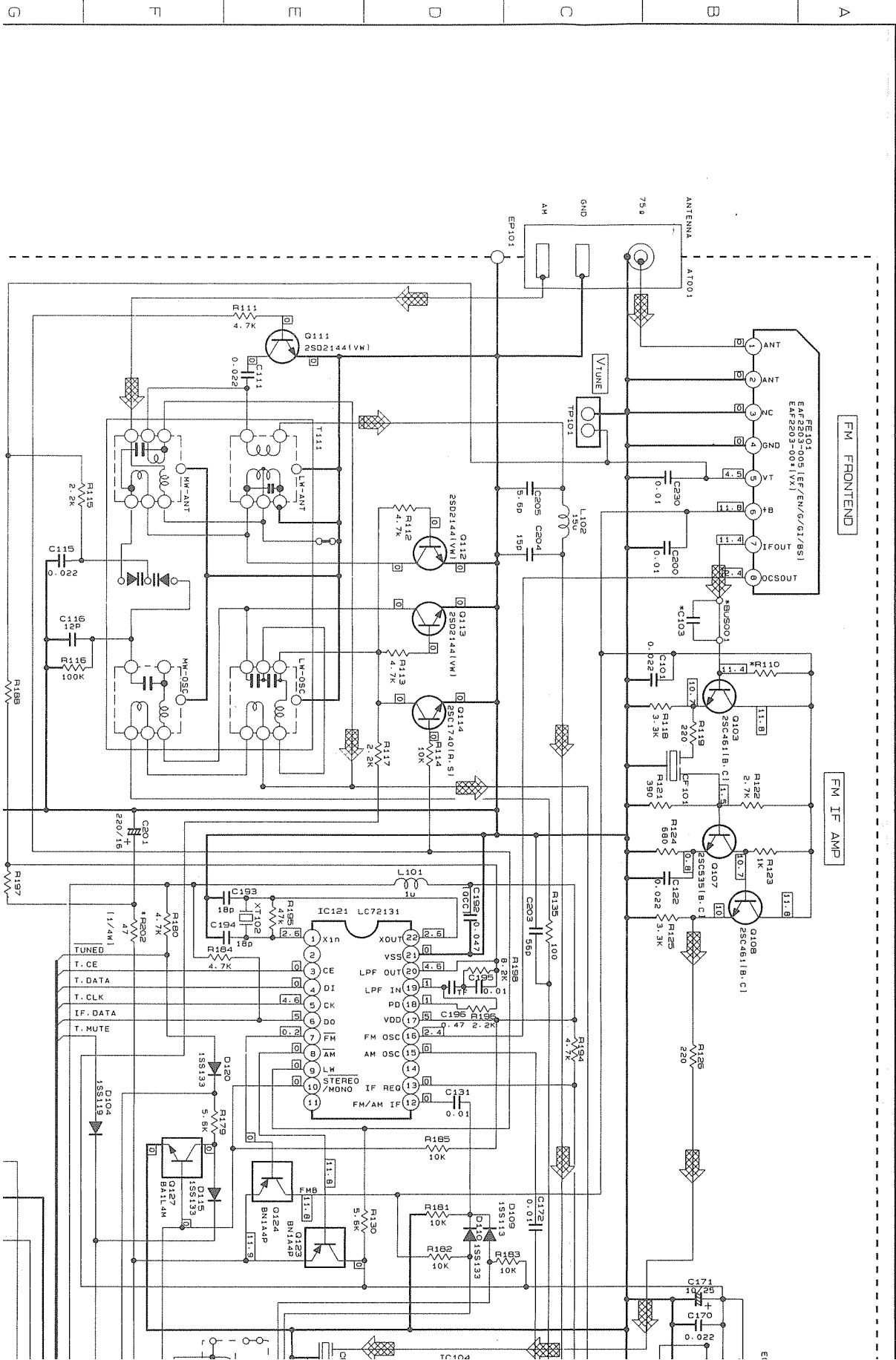

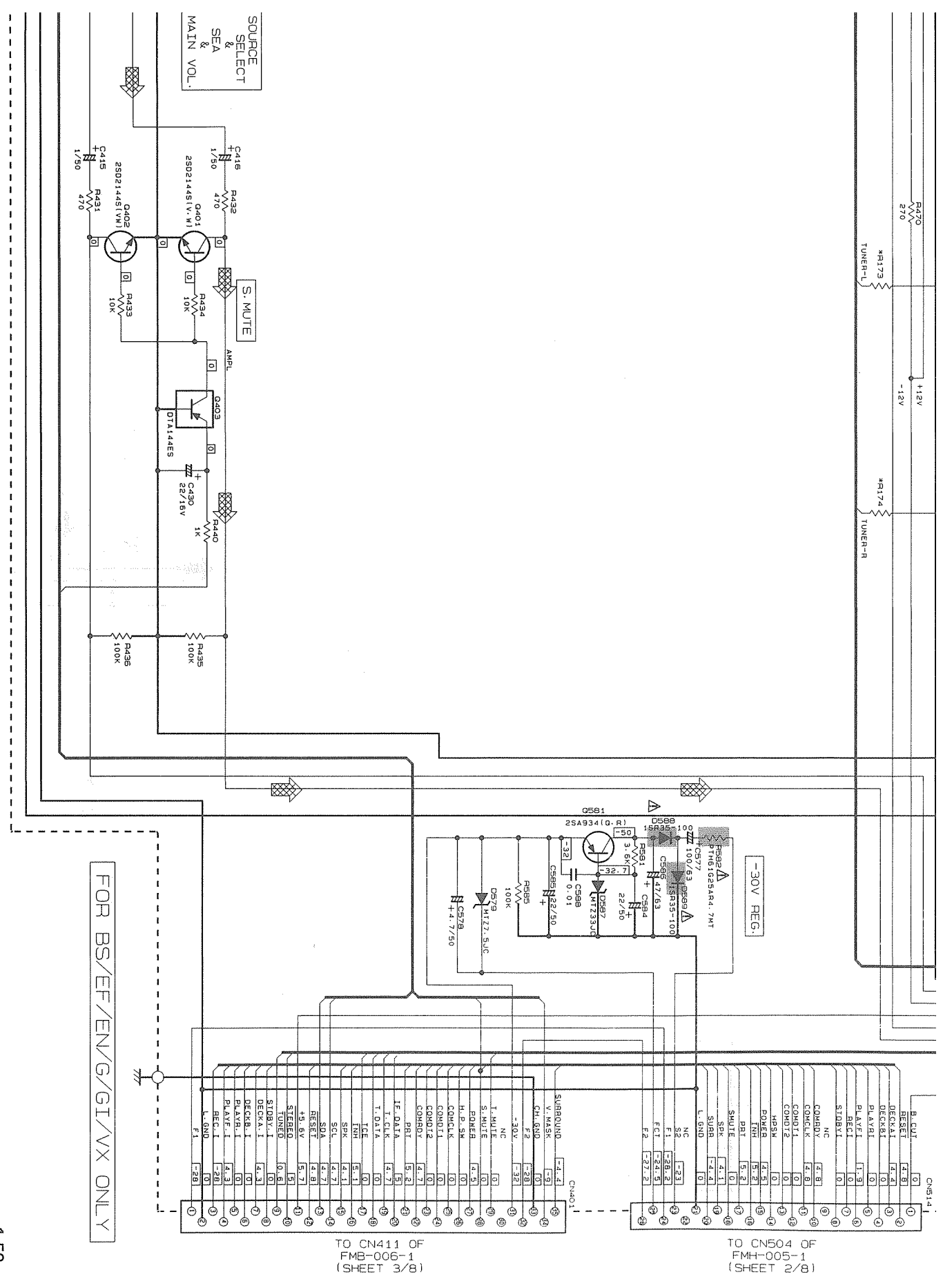

11 12 13 14 15 16 17 18 19 20

FMC-002-1

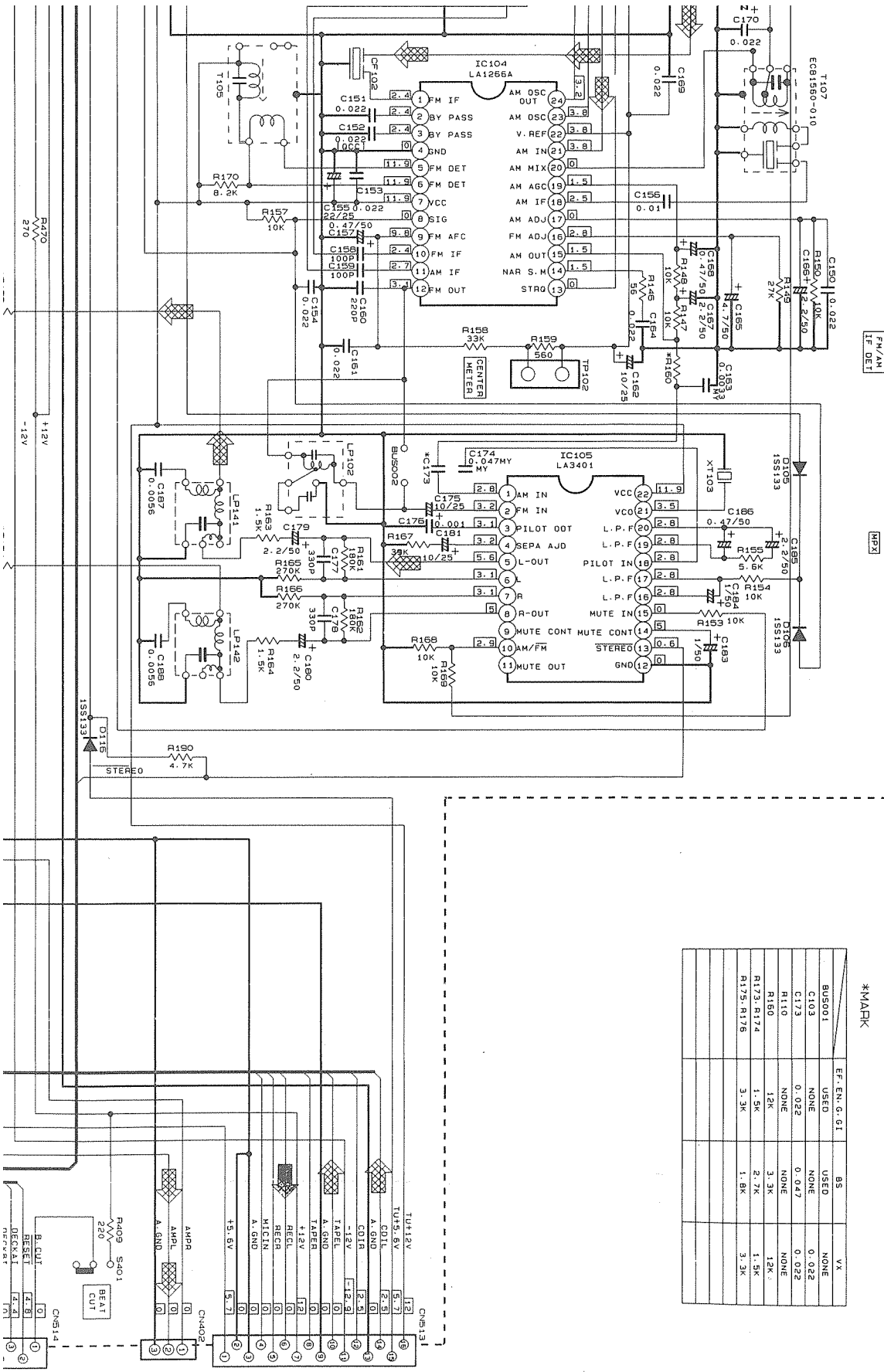

FM/AM  
IF DET

MPX

\*MARK

REF	EF. EN. G. G1	BS	VX
BUS001	USED	USED	NONE
C103	NONE	NONE	0.022
C173	0.022	0.047	0.022
R110	NONE	NONE	NONE
R160	12K	3.3K	13K
R173, R174	1.5K	2.7K	1.5K
R175, R176	3.3K	1.8K	3.3K

TO CN412 OF  
FMH-005-2  
(SHEET 2/8)

TO CN503 OF  
FMH-005-1  
(SHEET 2/8)

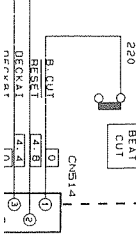



P1-60-a

P1-60-b

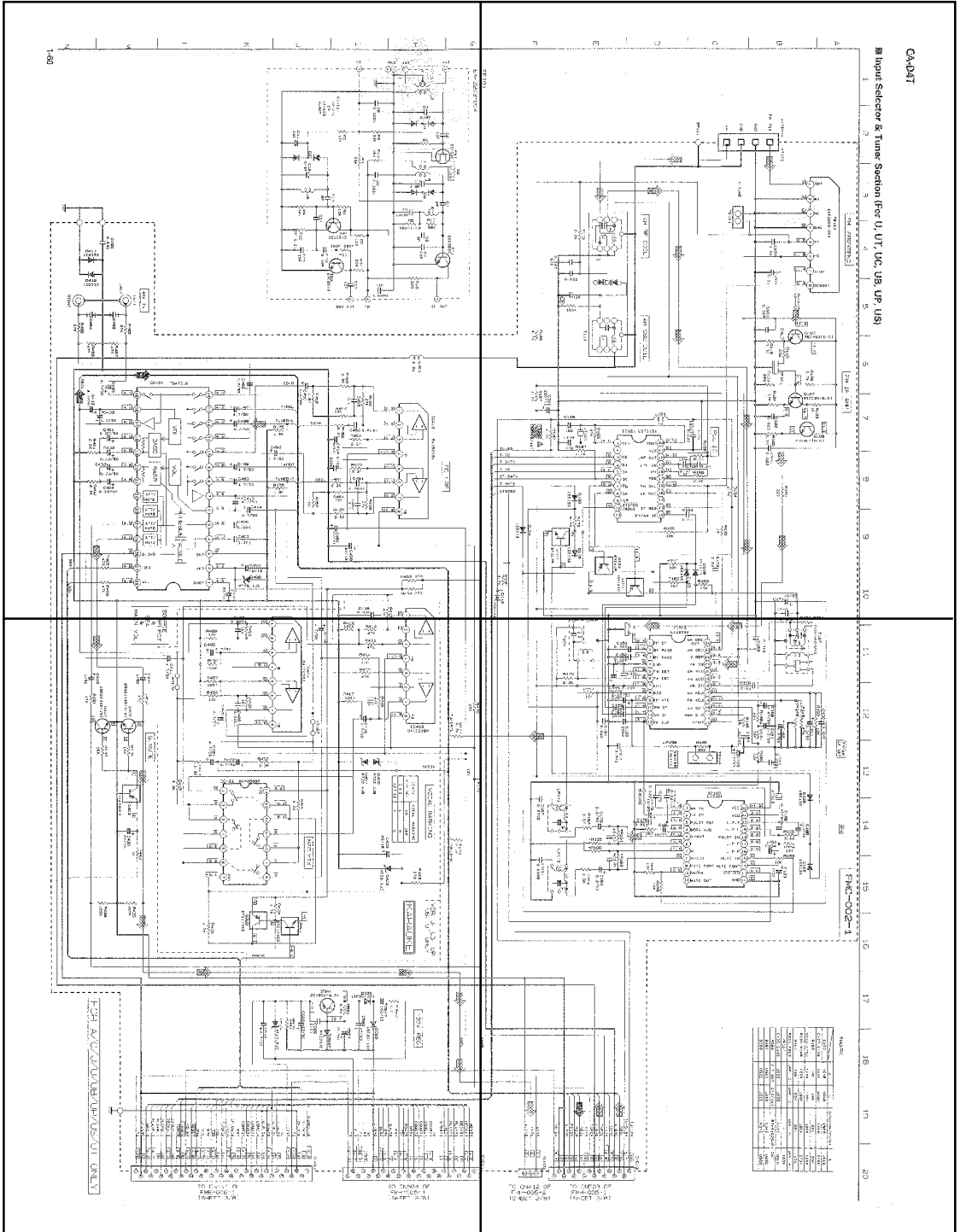

P1-60-c

P1-60-d

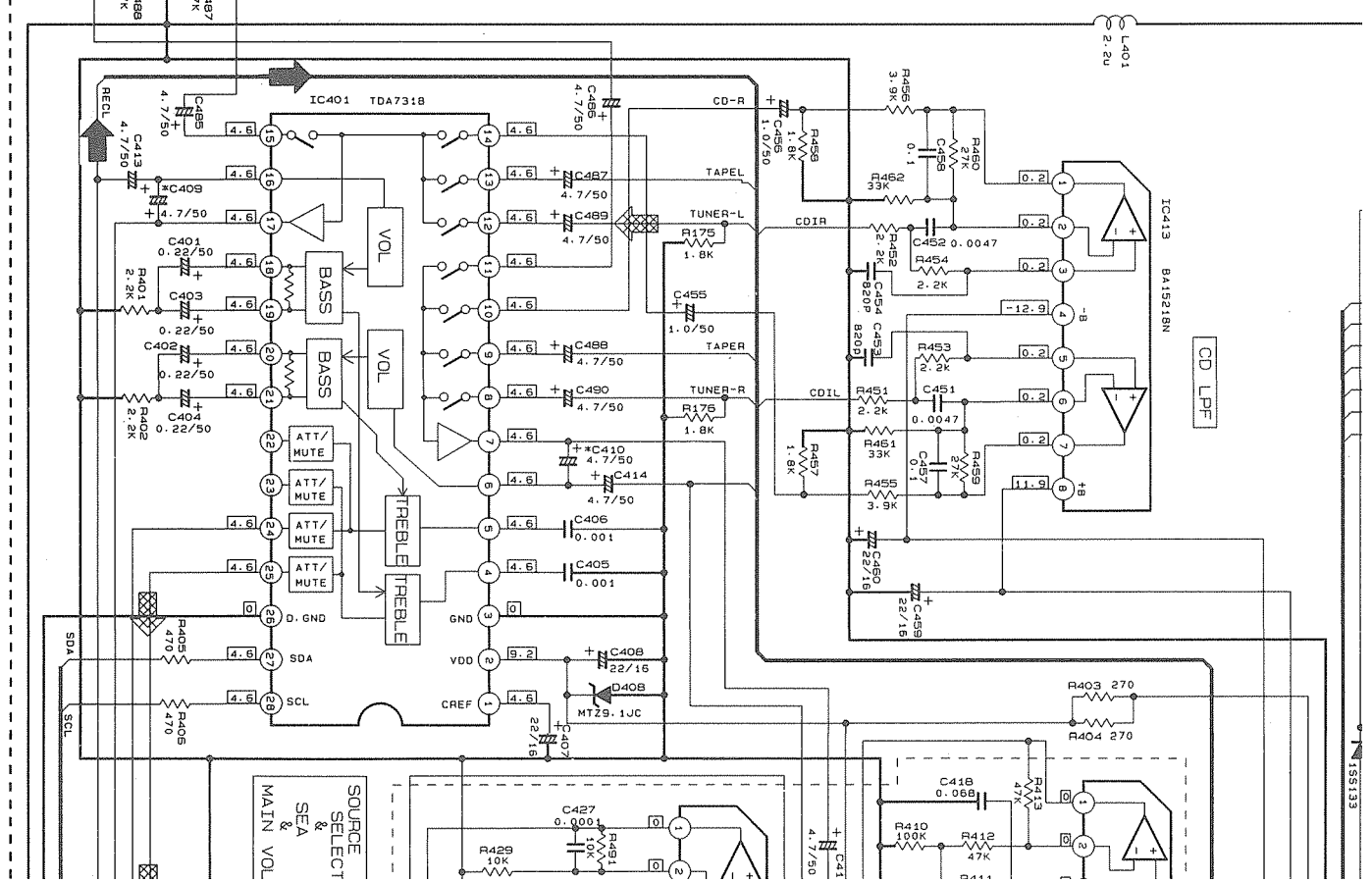
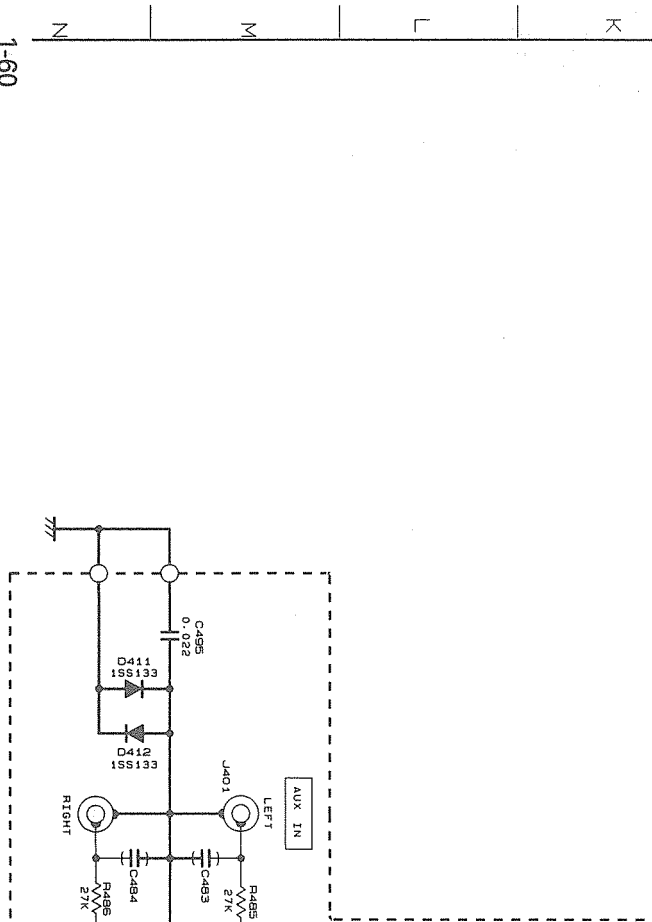
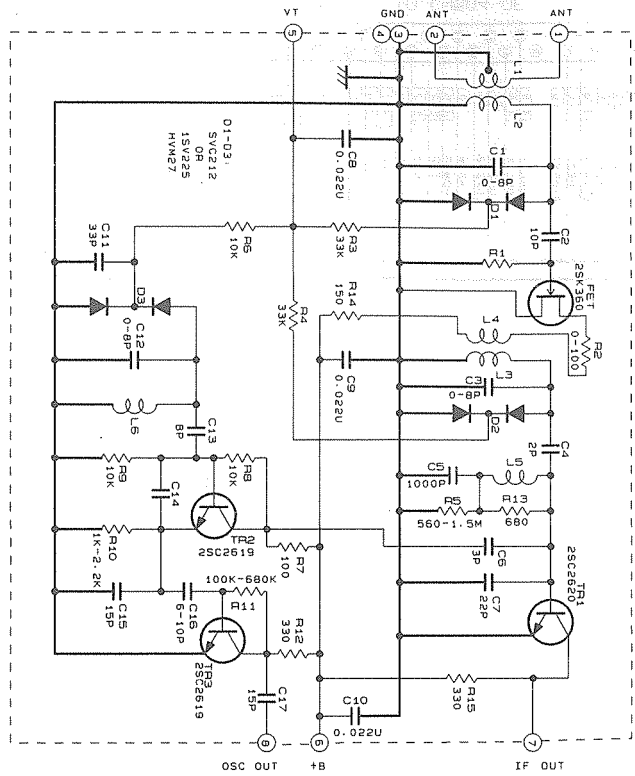

Input Selector & Tuner Section (For U, UT, UC, UB, UP, US)

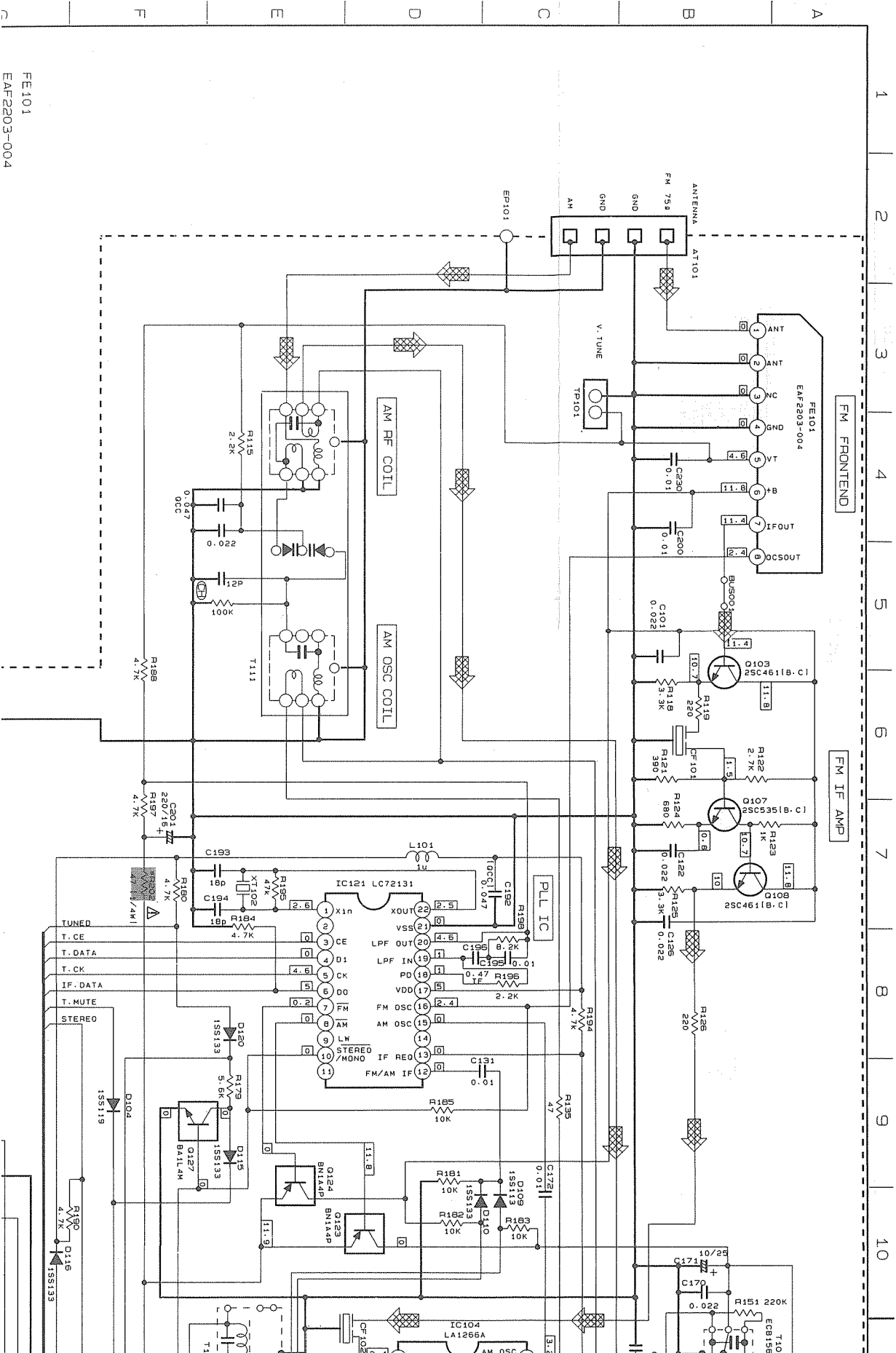

FE101  
EAF2203-004

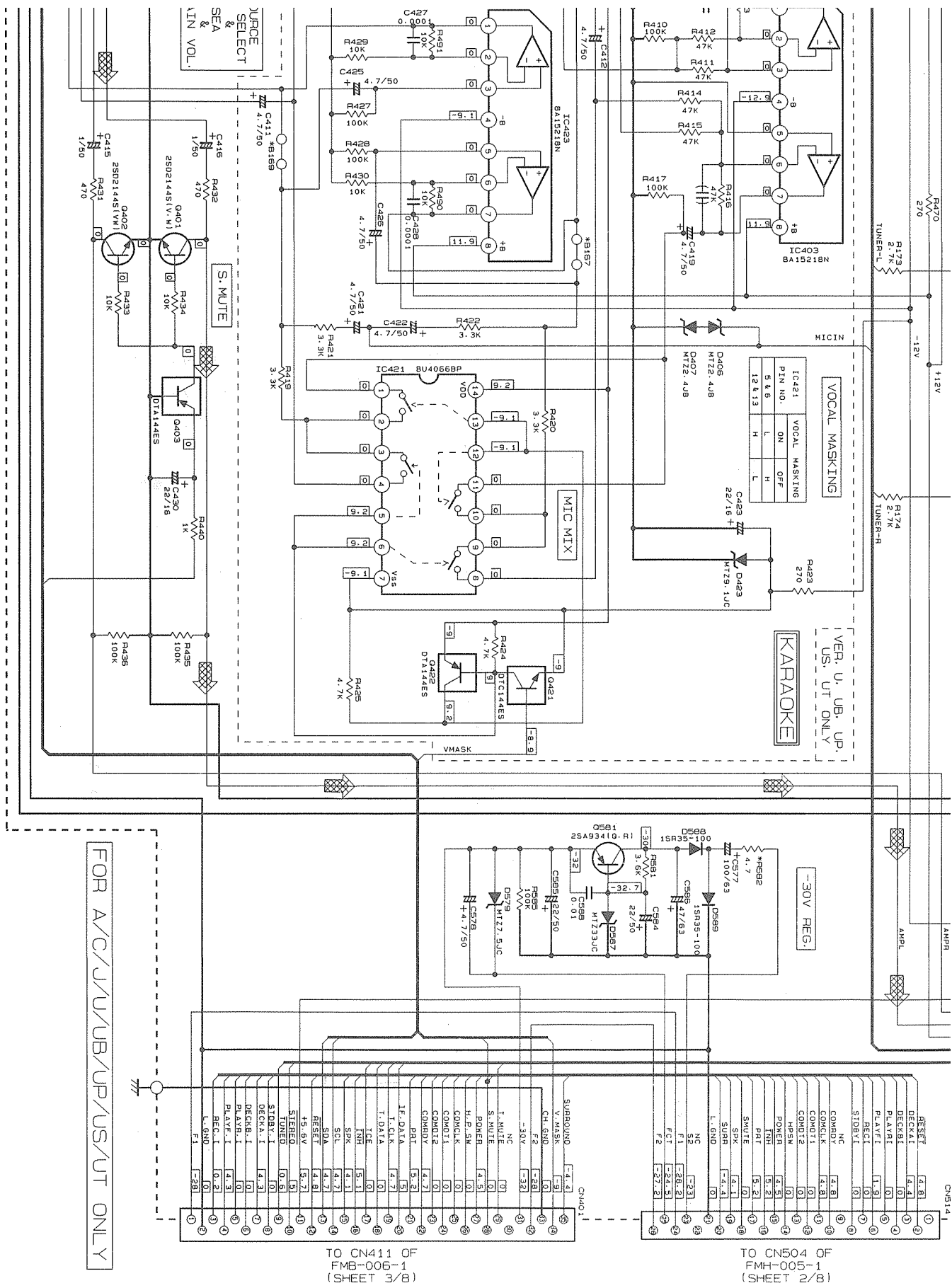



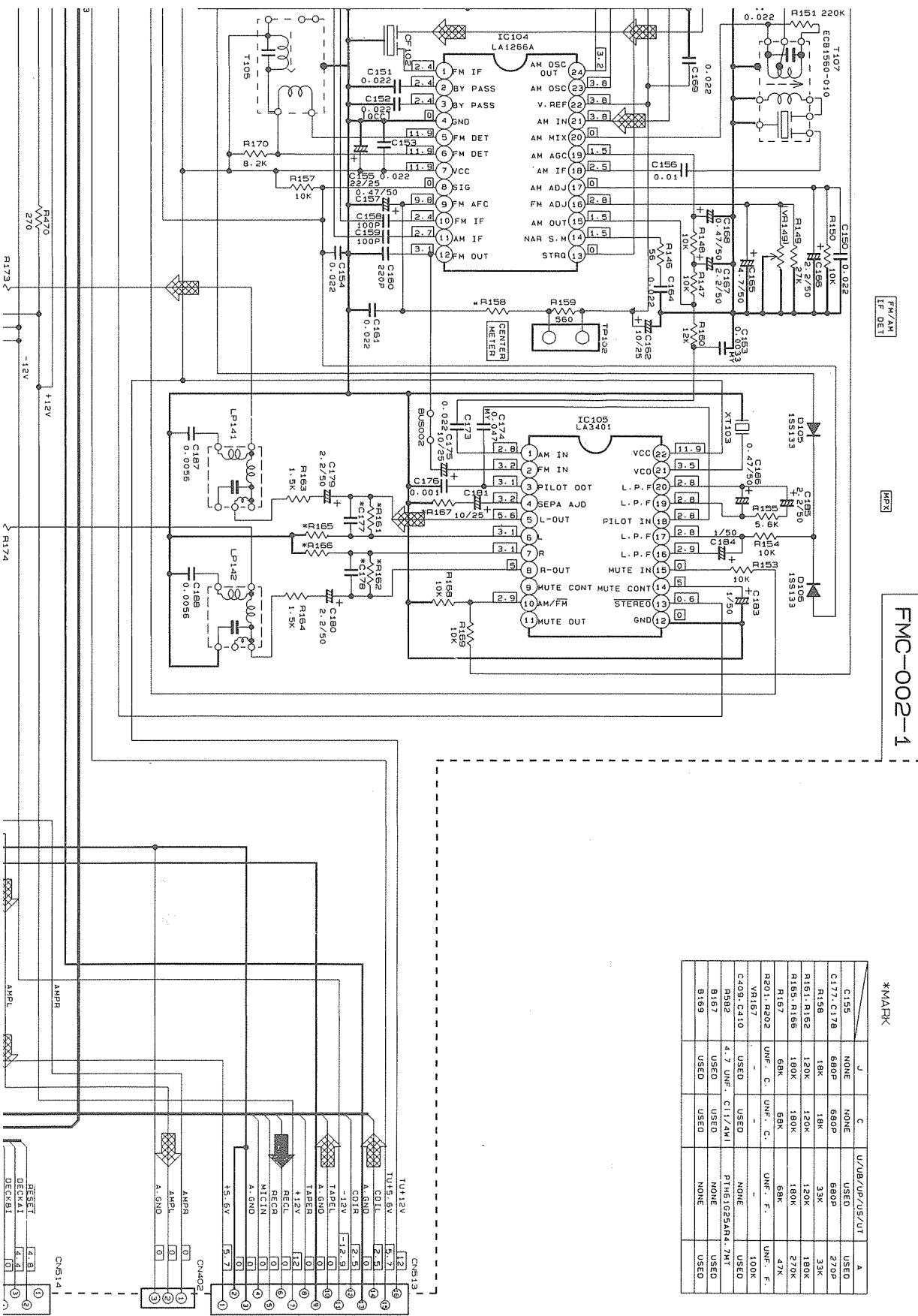

FM/AM  
IF DET

MPX

FMC-002-1

\*MARK

U	C	U/UB/UF/US/UT	A
C155	NONE	USED	USED
C177, C178	680P	680P	270P
R156	18K	33K	33K
R151, R152	120K	120K	180K
R155, R156	180K	180K	270K
R157	68K	68K	47K
R201, R202	UNF. C.	UNF. C.	UNF. F.
VR157	-	100K	100K
C409, C410	USED	USED	NONE
R592	4.7 UNF.	C11/4M1	PTH61G5A44.7M1
B167	USED	USED	NONE
B169	USED	USED	USED

TO CN412 OF  
FMH-005-2  
(SHEET 2/8)

TO CN503 OF  
FMH-005-1  
(SHEET 2/8)

CD Section

1 2 3 4 5 6 7 8 9 10 11

A  
B  
C  
D  
E  
F  
G  
H  
I  
J  
K  
L  
M  
N

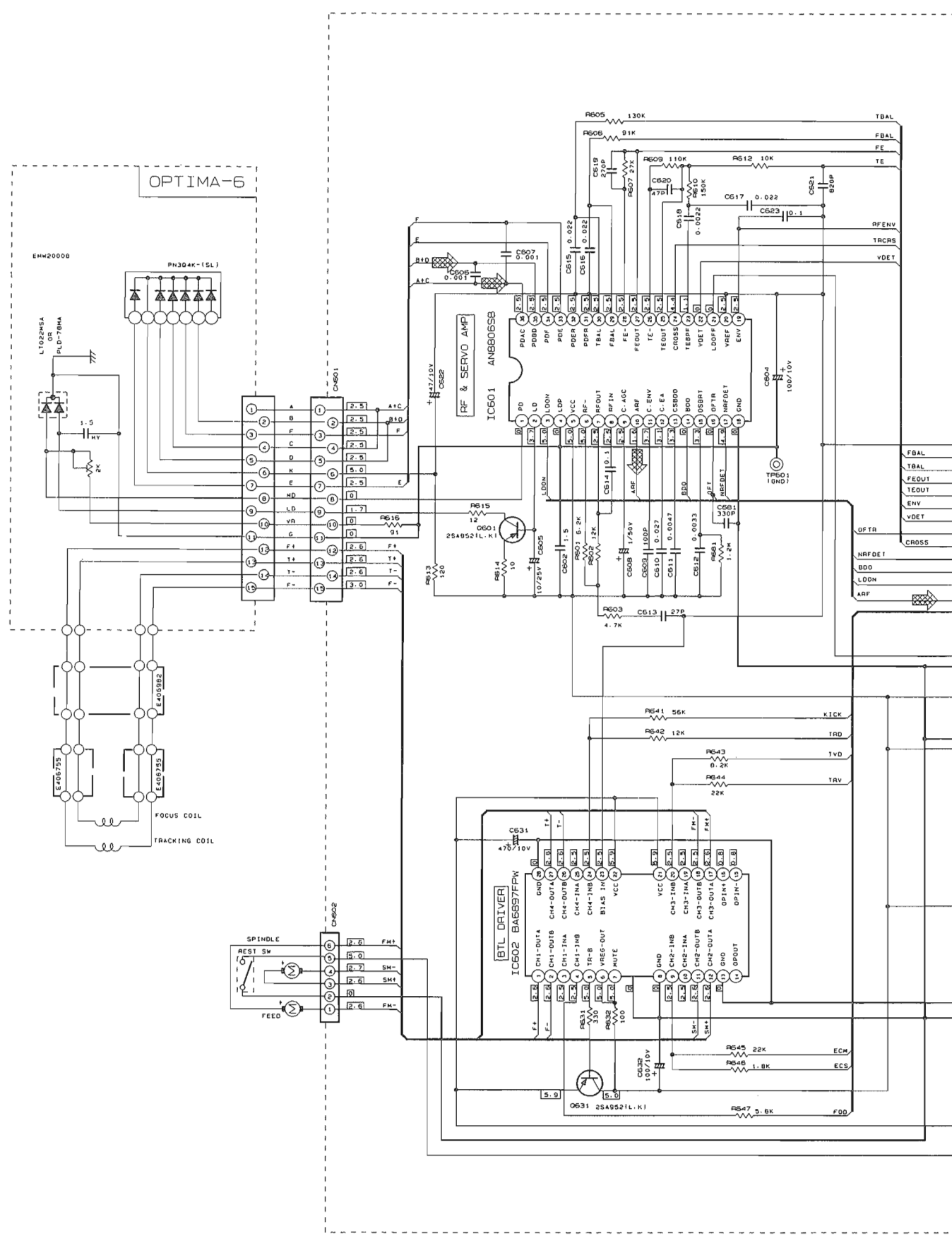

11 12 13 14 15 16 17 18 19 20

FMB-006-7

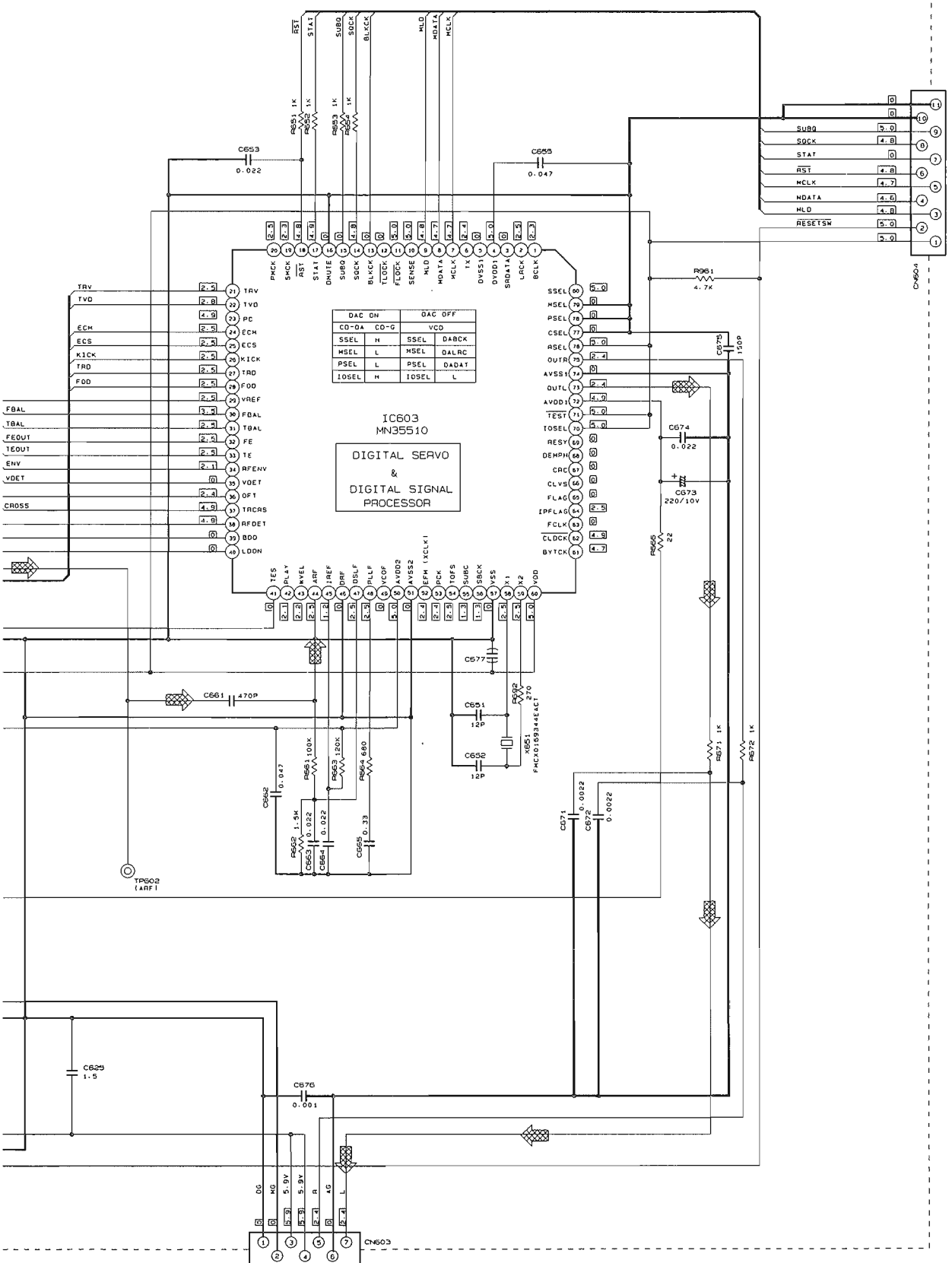

TO CN614 OF FMH-005-1 (SHEET 2/8)

TO CN613 OF FMH-005-1 (SHEET 2/8)

■ Front & MIK AMP (For U, UT, UC, UB, UP, US)

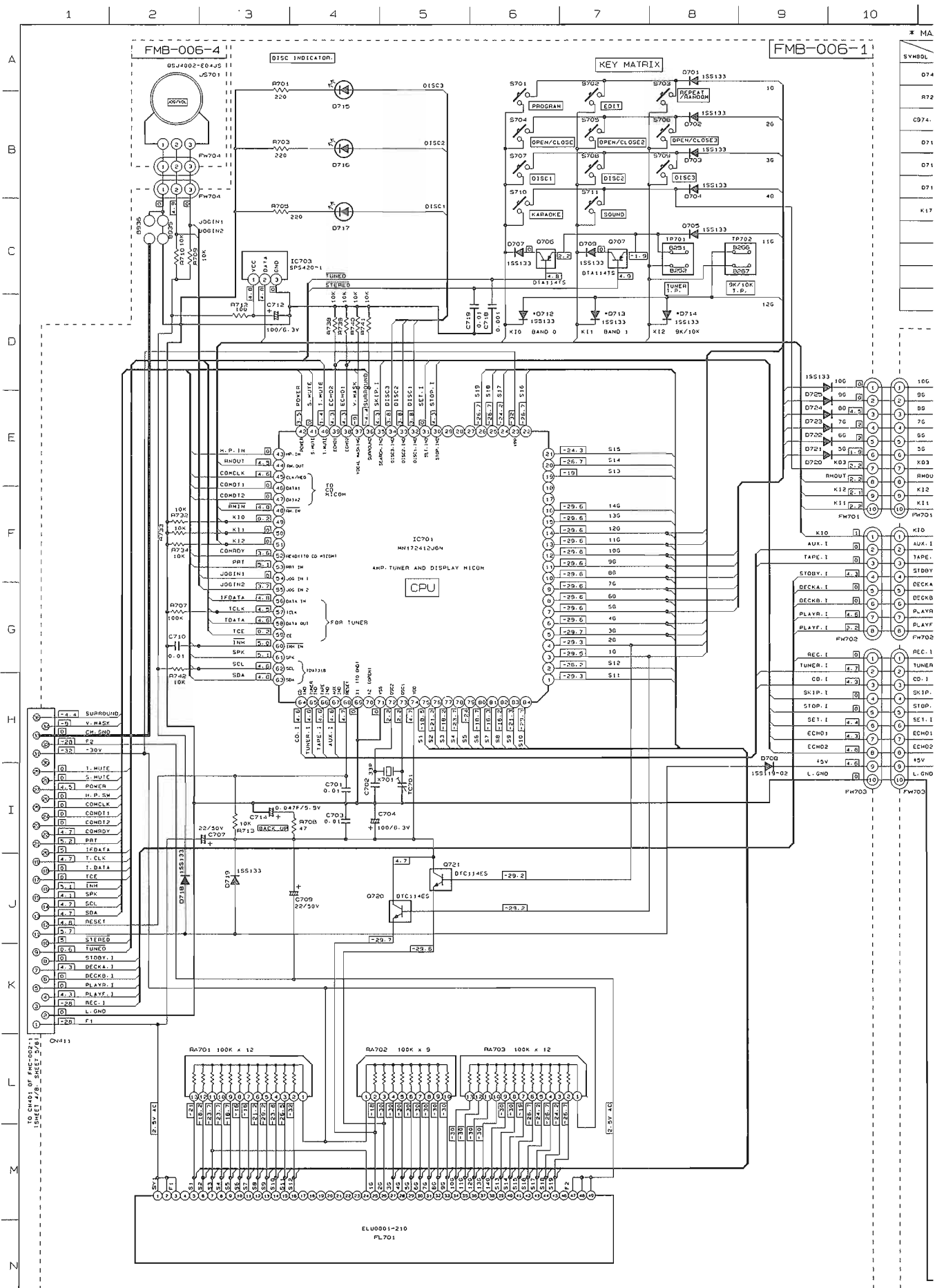

\* MARK

SYMBOL	VER	BS	G-DI-EF-EN-VX	OTHERS
D743	SLA-380L1447	SLR342VCA47	SLN342VCA47	
R728	470	220	220	
C974, C975	470P	470P	NONE	
D712	NONE	ONLY VX USED	ONLY U, UB, UP, US, UT USED	
D713	NONE	ONLY VX USED	ONLY C, J USED	
D714	NONE	NONE	ONLY A USED	
K1703	USED	USED	B1703 SHORT	

TO C-801 OF  
FORM-005-1  
1 SHEET 2/01

FMB-006-3



FMB-006-2

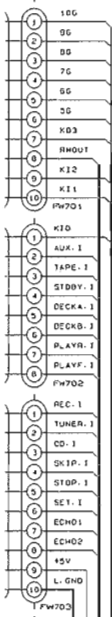
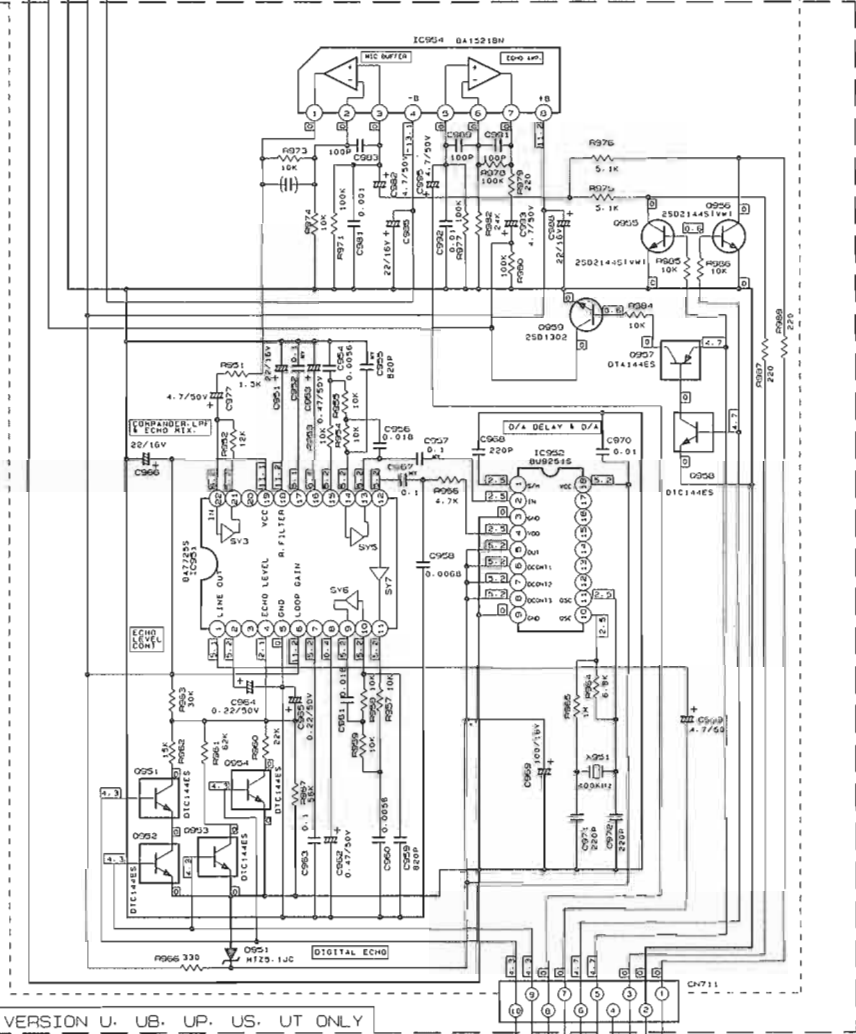

KEY MATRIX

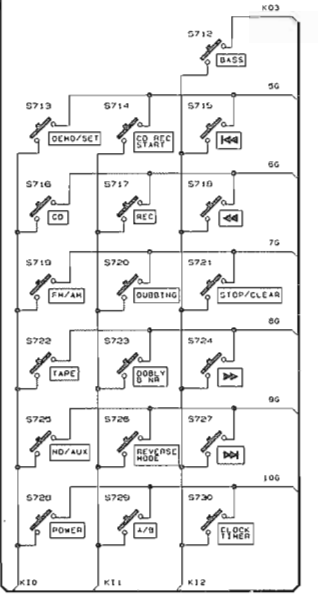

VERSION U, UB, UP, US, UT ONLY

SOURCE SELECT INDICATOR

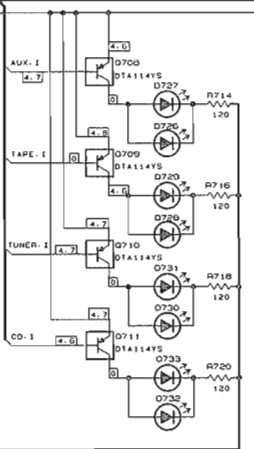

VERSION U, UB, UP, US, UT ONLY

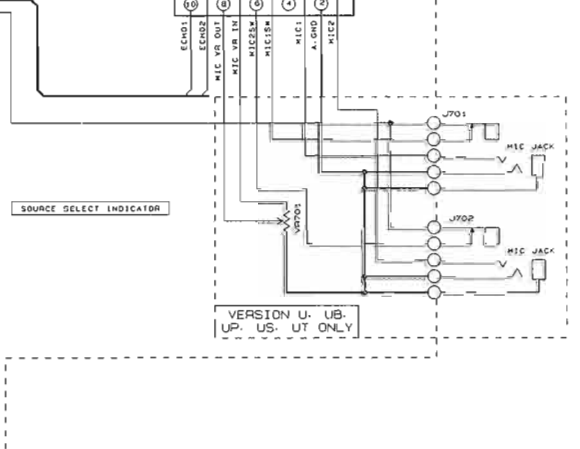

# Changer Mech. Control Section

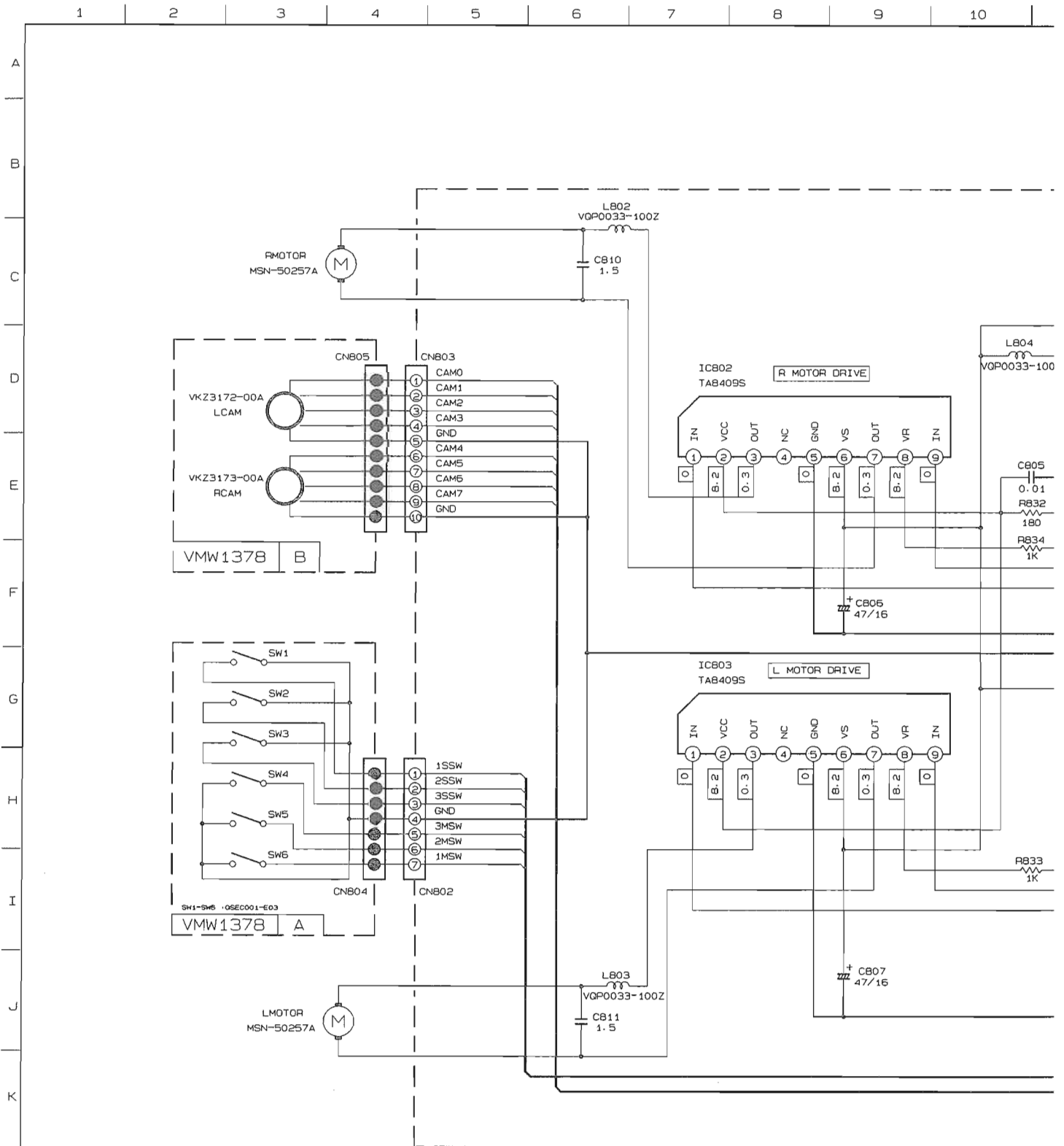

TABLE 1 CAM PATTERN LIST

CAM NO	LCAM				RCAM							POSITION
	0	1	2	3	4	5	6	7	8	9	10	
MAIN TRAY1	0	1	1	1	0	1	1	1	0			EMERGENCY
SUB TRAY1	0	0	1	1	0	1	1	0	0			TRAY1 STANDBY
CAM# 1	0	1	0	1	0	1	0	1	0			TRAY1 CHECKING
MAIN TRAY2	1	0	0	1	0	1	0	0	1			TRAY2 STANDBY
SUB TRAY2	1	1	1	0	0	0	1	1	1			TRAY2 CHECKING
CAM# 2	1	0	1	0	0	0	1	0	1			TRAY3 STANDBY
MAIN TRAY3	1	1	0	0	0	0	0	1	1			TRAY3 CHECKING
SUB TRAY3	1	0	0	0								
OFF	1	1	1	1	0	1	1	1	1			OFF

0=0V  
1=5V

11 12 13 14 15 16 17 18 19 20

TO CNB11 OF  
FMH-005-1  
(SHEET 2/8)

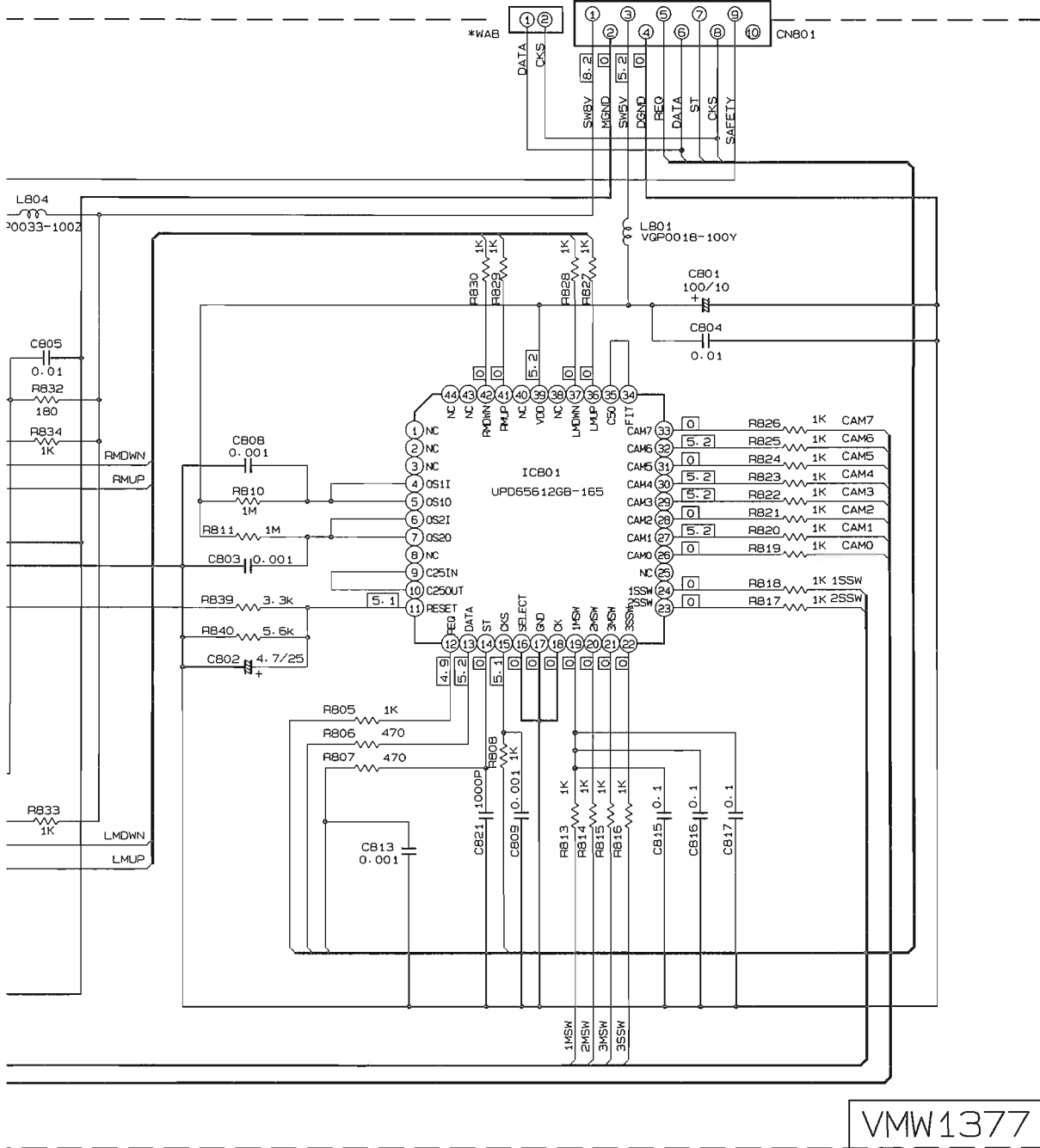

VMW1377

■ Power Supply BLOCK.

1 | 2 | 3 | 4 | 5 | 6 | 7 | 8 | 9 | 10

A  
B  
C  
D  
E  
F  
G  
H  
I  
J  
K  
L  
M

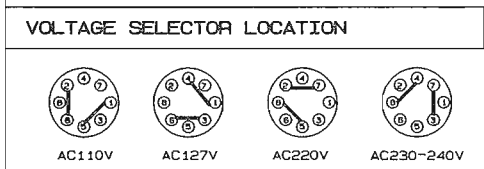
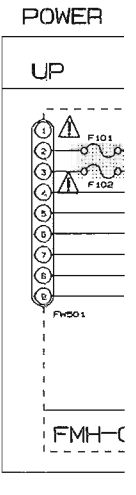
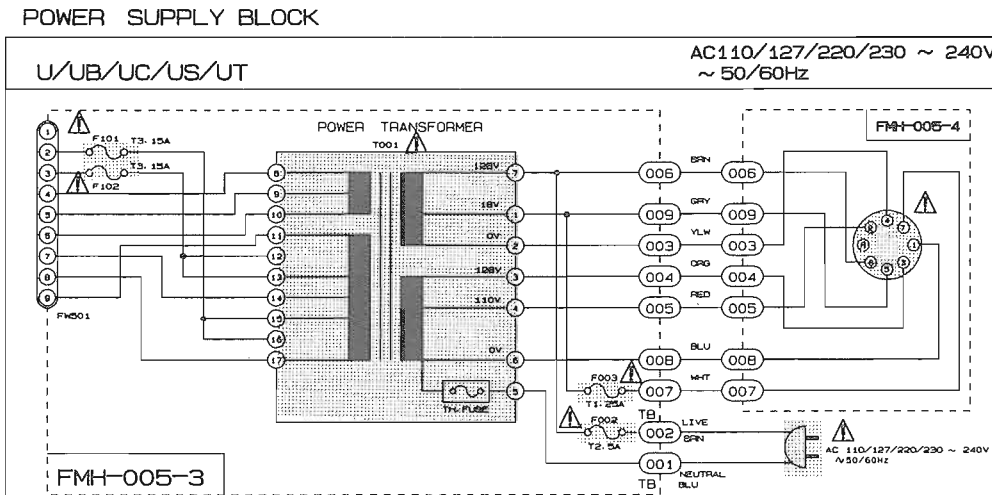
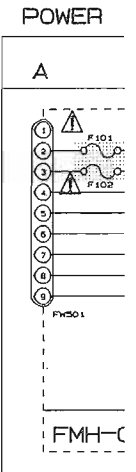
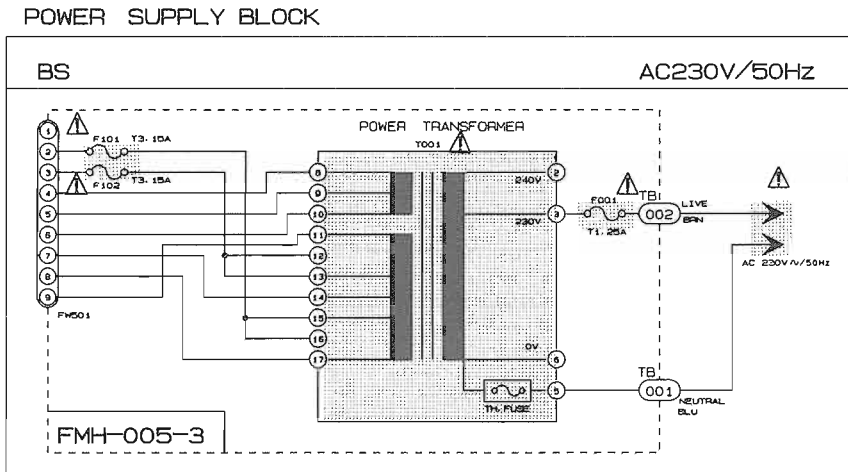
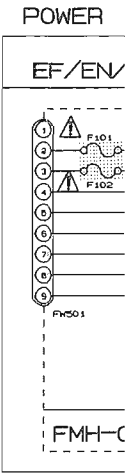
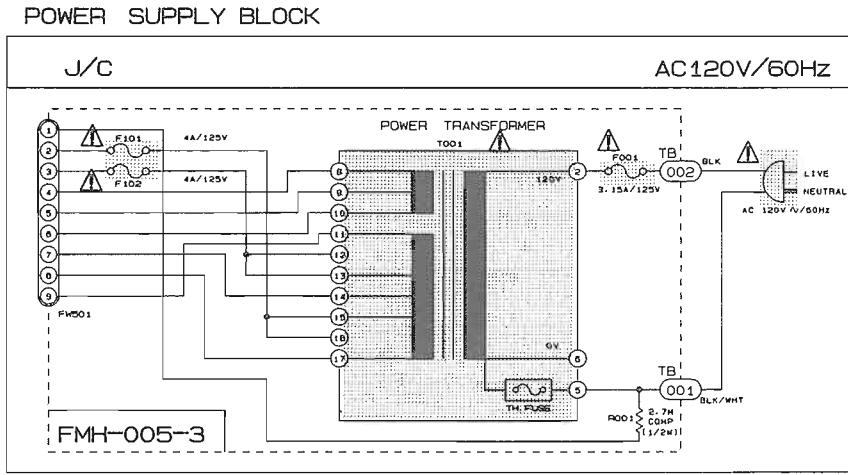



## POWER SUPPLY BLOCK

RF/EN/G/GI/VX

AC230V/50Hz

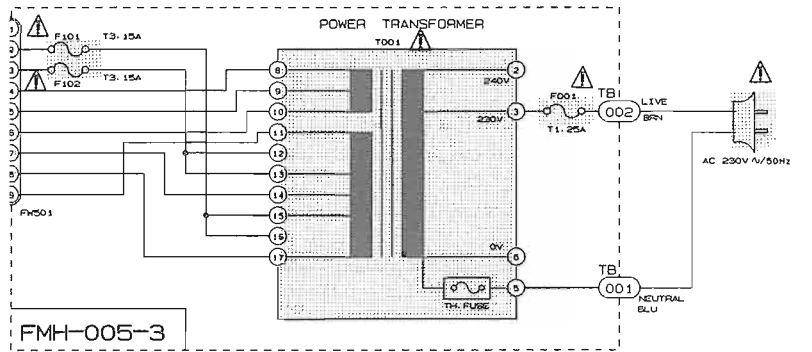

## VERSION CODES:

J : U. S. A.  
 C : CANADA  
 EN : NORDIC COUNTRIES  
 EF : CONTINENTAL EUROPE EXCEPT GERMANY AND ITALY  
 G : GERMANY  
 GI : ITALY  
 VX : EASTERN EUROPE  
 BS : U. K.  
 A : AUSTRALIA  
 UP : KOREA  
 UB : HONG KONG  
 US : SINGAPORE  
 UT : TAIWAN  
 U : UNIVERSAL EXCEPT ALL OF ABOVE

## POWER SUPPLY BLOCK

AC240V/50Hz

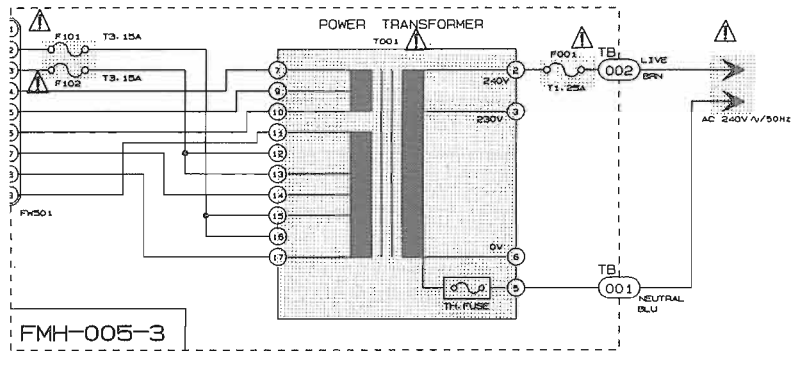

## EXPLANATION OF OVERALL SCHEMATIC

MODEL CA-D4T

SHEET NUMBER	MODEL NUMBERS	CIRCUITS DESCRIPTION
1/8	CA-D4T	PRIMARY WITH MAINS TRANSFORMER
2/8	CA-D4T	• DECK/CD CONTROL MICOM • POWER AMPLIFIER • DC REGULATORS
3/8	CA-D4T	• AMP. TUNER AND DISPLAY CONTROL MICOM • FL AND USER CONTROL KEYS • DIGITAL ECHO (ONLY FOR U/UB/UP/US/UT)
4/8	CA-D4T	• TUNER RF/IF/FM MULTIPLEX (ONLY FOR A/C/J/U/UB/UP/US/UT) • SIGNAL INPUT JACK. SOURCE SELECT. SEA AND MAIN VOL. • KARAOKE (ONLY FOR U/UB/UP/US/UT) • -30V REGULATOR
5/8	CA-D4T	• TUNER RF/IF/FM MULTIPLEX (ONLY FOR BS/EF/EN/G/GI/VX) • SIGNAL INPUT JACK. SOURCE SELECT. SEA AND MAIN VOL. • -30V REGULATOR
6/8	CA-D4T	MISCELLANEOUS CIRCUIT FOR TAPE DECK SUCH AS AMPLIFIER, SWITCH, BIAS AND OTHERS
7/8	CA-D4T	DIGITAL SERVO AND DIGITAL SIGNAL PROCESSOR FOR CD
8/8	CA-D4T	CD MECHANISM CONTROL

## NOTES:

1. MARK (\*) IS TO SHOW DEVIATION IN VERSIONS. DETAILS ARE EXPLAINED NEAR THE MARK.

## POWER SUPPLY BLOCK

AC220V/50Hz

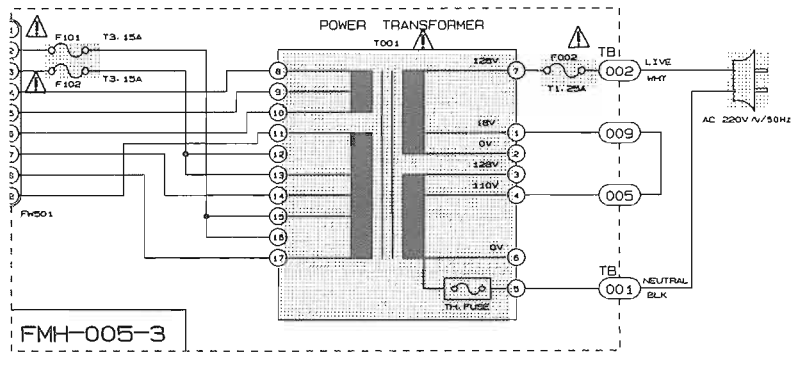



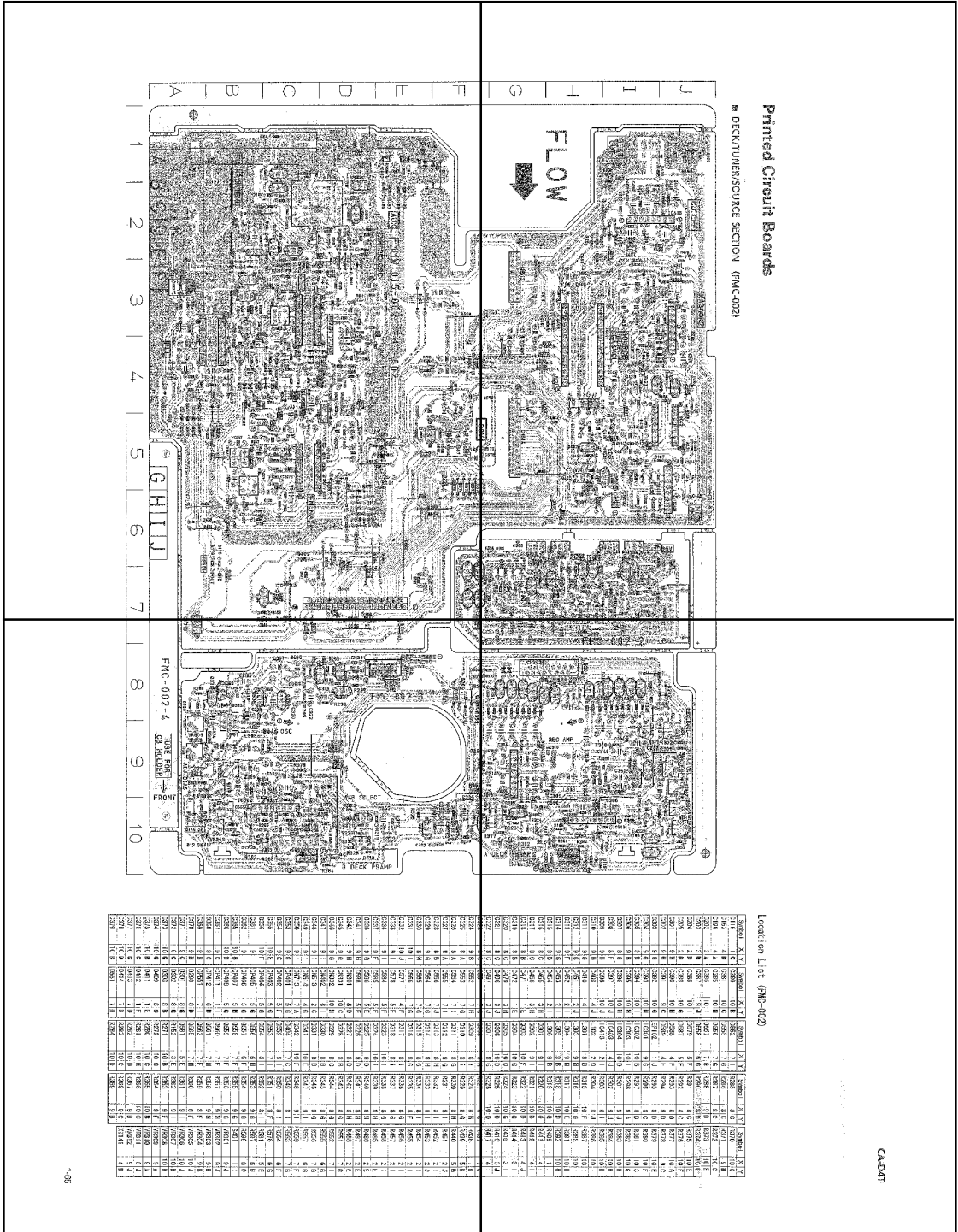

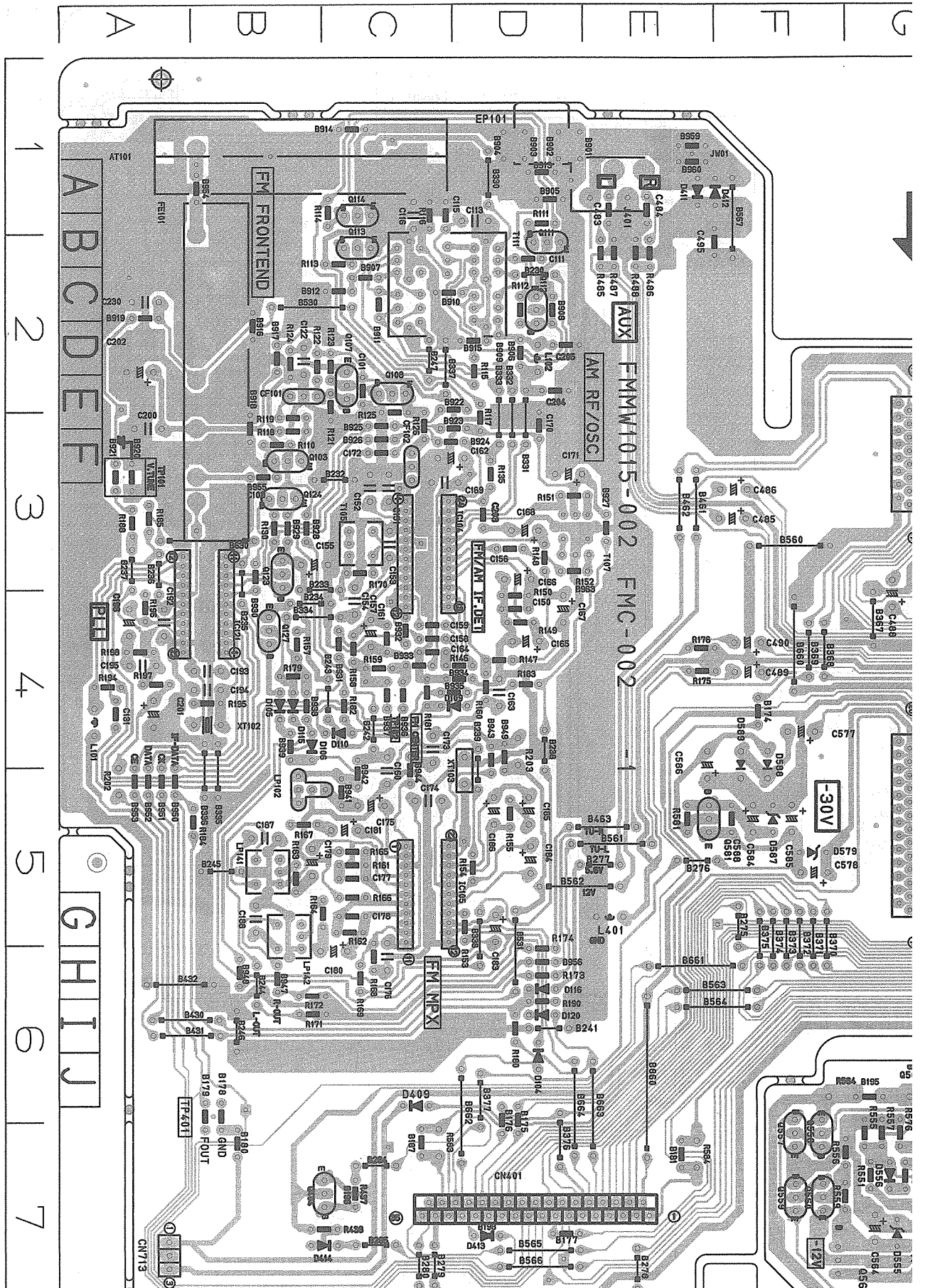

# Printed Circuit Boards

■ DECK/TUNER/SOURCE SECTION (FMC-002)

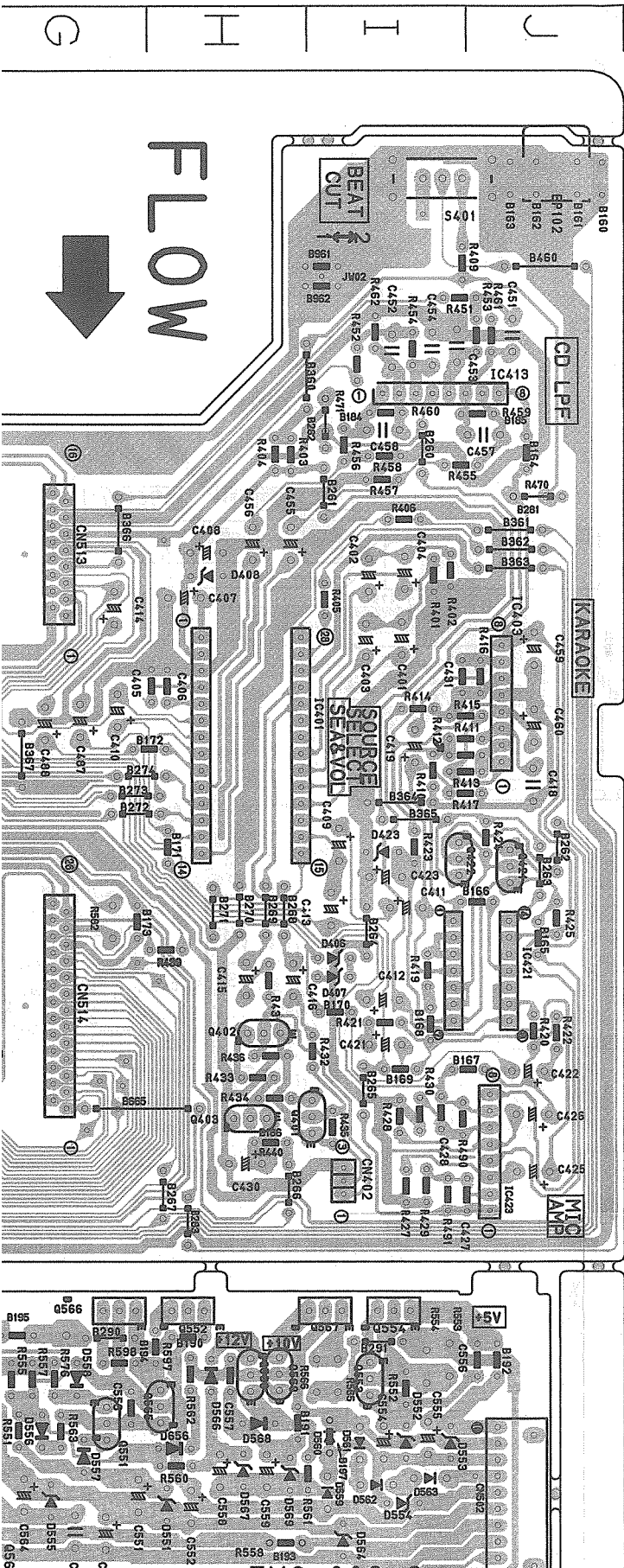

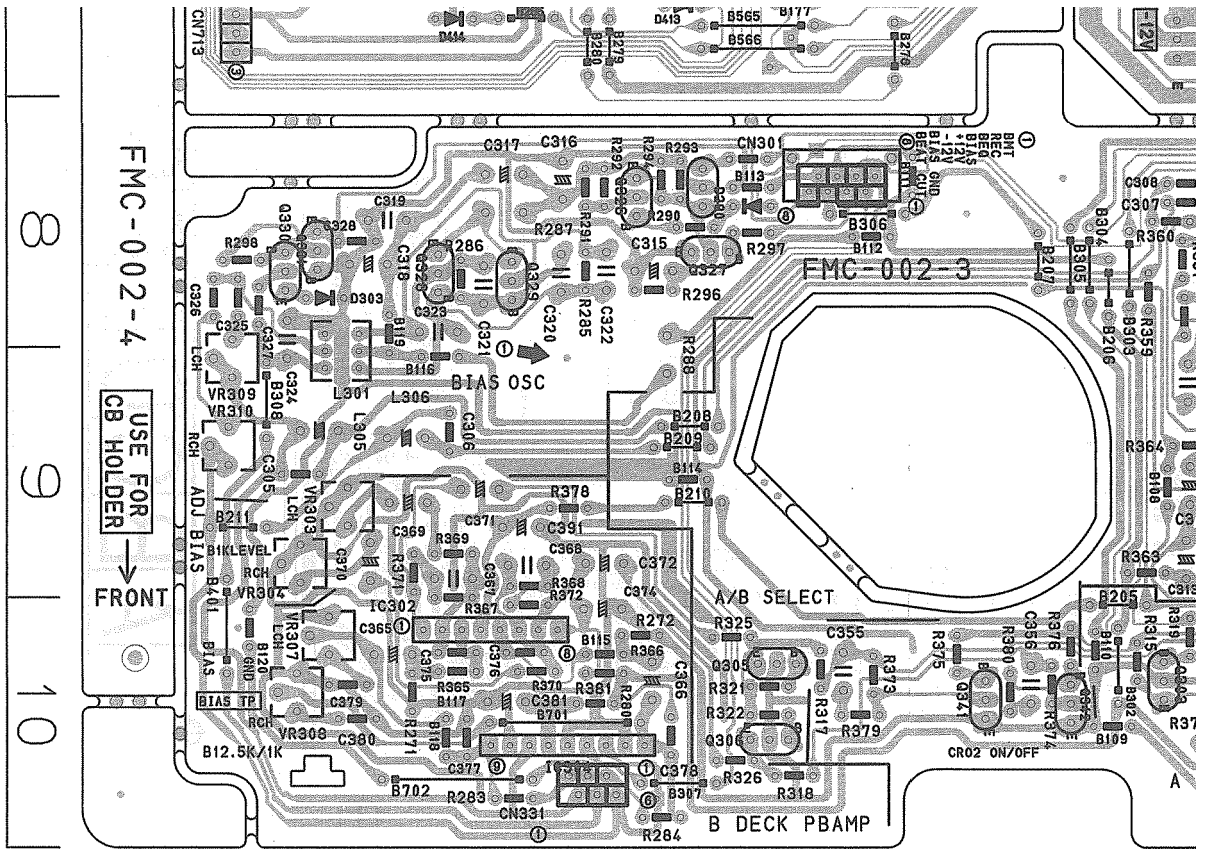

C322	8 C	C497	3 J	Q307	8 G	R326	10 D	R417	4 I
C323	8 C	C551	7 G	Q308	8 H	R327	8 G	R437	7 C
C324	9 B	C552	7 H	Q309	8 I	R328	8 H	R438	7 B
C325	8 A	C553	7 G	Q310	8 I	R329	8 G	R439	5 H
C326	8 A	C554	7 I	Q311	8 G	R330	8 H	R440	5 H
C327	8 A	C555	7 I	Q312	8 G	R331	8 I	R451	2 J
C328	8 B	C556	7 J	Q313	8 H	R332	8 I	R452	2 I
C329	9 G	C564	7 G	Q314	8 H	R333	8 I	R453	2 J
C330	8 H	C565	7 G	Q315	8 G	R334	8 I	R454	2 I
C331	10 I	C566	7 G	Q316	8 G	R335	8 F	R455	2 I
C332	10 J	C577	4 F	Q317	8 I	R336	8 G	R456	2 I
C333	9 I	C578	5 F	Q318	8 I	R337	8 G	R457	2 I
C334	9 I	C584	5 F	Q323	10 I	R338	8 G	R458	2 I
C337	9 F	C585	5 F	Q324	10 I	R339	8 H	R485	2 E
C338	9 G	C586	5 E	Q325	8 D	R340	8 H	R486	2 E
C341	9 H	C588	5 F	Q326	8 D	R341	8 H	R487	2 E
C342	9 H	CN301	8 D	Q327	8 D	R342	8 H	R488	2 E
C345	9 G	CN331	10 C	Q328	8 B	R343	8 G	R551	7 G
C346	9 G	CN332	10 H	Q329	8 C	R344	8 G	R552	7 I
C347	9 I	CN402	6 I	Q330	8 B	R345	8 G	R555	6 G
C348	9 I	CN513	2 G	Q331	8 B	R346	8 G	R556	7 G
C349	9 I	CN514	4 G	Q341	10 E	R347	9 I	R557	6 G
C350	9 I	CN713	7 A	Q342	10 F	R348	9 I	R559	7 F
C353	9 G	CP401	5 G	Q404	7 C	R349	8 I	R563	7 G
C354	9 G	CP402	5 F	Q52	6 I	R350	8 I	R564	6 F
C355	10 E	CP403	5 G	Q53	7 I	R351	8 F	R576	6 G
C356	10 F	CP404	5 G	Q54	6 I	R352	8 I	R581	5 E
C361	9 I	CP405	5 G	Q56	6 H	R353	9 G	R597	6 H
C362	9 I	CP406	5 G	Q57	6 F	R354	9 G	R598	6 G
C365	10 B	CP407	5 H	Q58	7 F	R355	9 G	S401	1 I
C366	10 D	CP408	5 G	Q59	7 F	R356	9 G	VR301	9 J
C367	9 C	CP411	1 I	Q60	7 F	R357	9 H	VR302	9 J
C368	9 C	CP412	6 B	Q61	7 H	R358	9 H	VR303	9 B
C369	9 B	CP551	7 I	Q63	7 F	R359	8 F	VR304	9 B
C370	9 B	D290	8 D	Q65	7 H	R360	8 F	VR305	10 J
C371	9 C	D301	8 G	Q68	5 E	R361	9 I	VR306	10 J
C372	9 C	D302	8 G	R152	3 E	R362	9 I	VR307	10 B
C373	10 G	D303	8 B	R271	10 B	R363	9 F	VR308	10 B
C374	10 C	D409	6 C	R272	10 C	R364	9 F	VR309	9 A
C375	10 B	D411	1 E	R280	10 C	R365	10 B	VR310	9 A
C376	10 C	D412	1 F	R281	10 H	R366	10 C	VR311	8 J
C377	10 C	D413	7 D	R282	10 H	R367	9 B	VR312	9 J
C378	10 D	D414	7 B	R283	10 C	R368	9 C	X1141	4 D
C379	10 B	D551	7 H	R284	10 D	R369	9 B		

Location List (FMC-002)

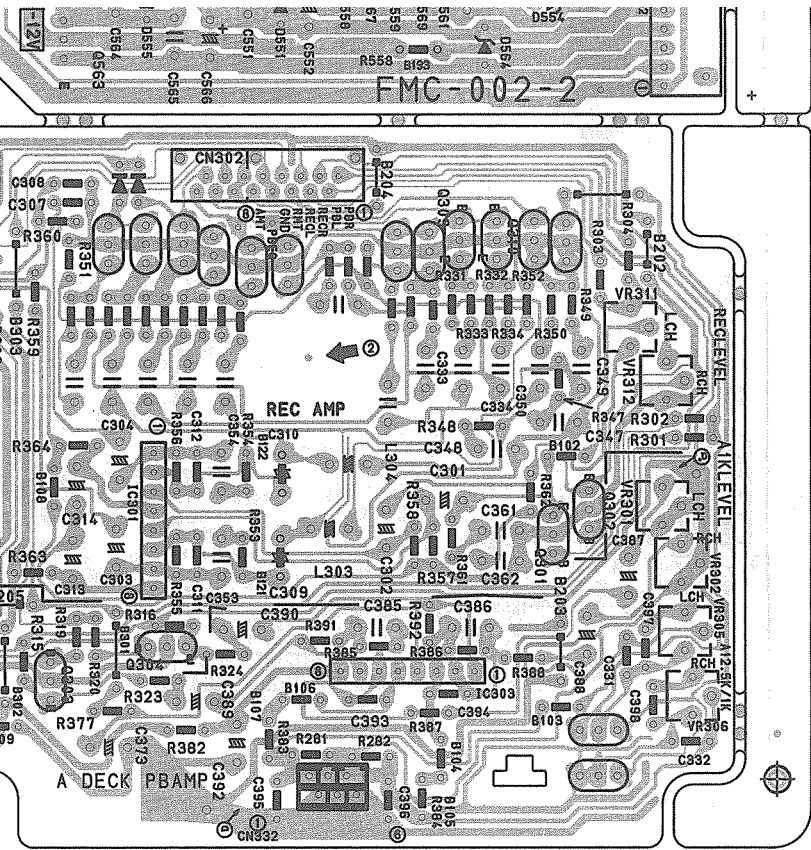

Symbol	X	Y	Symbol	X	Y	Symbol	X	Y	Symbol	X	Y	Symbol	X	Y
C116	1	C	G380	10	B	D552	7	I	R285	8	C	R370	10	C
C163	4	D	G381	10	C	D555	7	G	R286	8	C	R371	9	B
C196	4	A	G385	10	H	D556	7	G	R287	8	C	R372	10	C
C202	2	A	G386	10	I	D557	7	G	R288	9	D	R373	10	E
C203	3	D	G387	9	J	D558	6	G	R290	8	D	R374	10	F
C204	2	D	G388	10	I	D579	5	F	R291	8	C	R375	10	E
C205	2	D	G389	10	G	D587	5	F	R292	8	C	R376	10	F
C301	9	H	G390	10	H	D588	4	F	R293	8	D	R377	10	G
C302	9	H	G391	9	C	D589	4	F	R294	8	D	R378	9	C
C303	9	G	G392	10	G	EP102	1	J	R295	8	D	R379	10	E
C304	9	G	G393	10	H	IC301	9	G	R296	8	C	R380	10	F
C305	9	B	G394	10	I	IC302	10	B	R297	8	D	R381	10	C
C306	9	B	G395	10	H	IC303	10	I	R298	8	A	R382	10	G
C307	8	G	G396	10	H	IC304	10	D	R301	9	J	R383	10	H
C308	8	F	G397	10	J	IC403	4	J	R302	9	J	R384	10	H
C309	9	H	G398	10	J	IC413	2	I	R303	8	I	R385	10	H
C310	9	H	G409	4	J	L102	2	D	R304	8	J	R386	10	I
C311	9	G	G410	4	I	L301	9	B	R315	10	F	R387	10	I
C312	9	G	G451	2	J	L303	9	H	R316	10	G	R388	10	I
C313	9	F	G452	2	I	L304	9	H	R317	10	E	R391	10	H
C314	9	G	G453	2	I	L305	9	B	R318	10	D	R392	10	H
C315	8	D	G454	2	I	L306	9	B	R319	10	G	R409	1	I
C316	8	C	G455	3	H	IC301	9	I	R320	10	G	R411	4	I
C317	8	C	G456	3	H	IC302	9	I	R321	10	D	R412	4	I
C318	8	B	G471	1	E	IC303	10	F	R322	10	D	R413	4	J
C319	8	B	G472	1	E	IC304	10	G	R323	10	G	R414	3	I
C320	8	C	G479	3	H	IC305	10	D	R324	10	G	R415	3	I
C321	8	C	G496	3	J	IC306	10	D	R325	10	D	R416	3	J
C322	8	C	G497	3	J	IC307	8	G	R326	10	D	R417	4	I
C323	8	C	G551	7	G	IC308	8	H	R327	8	G	R437	7	C
C324	9	B	G552	7	H	IC309	8	I	R328	8	H	R438	7	B





P1-66-b

CADD  
 ■ DECK/CD CONTROL, / POWER SUPPLY SECTION (FMH-005)

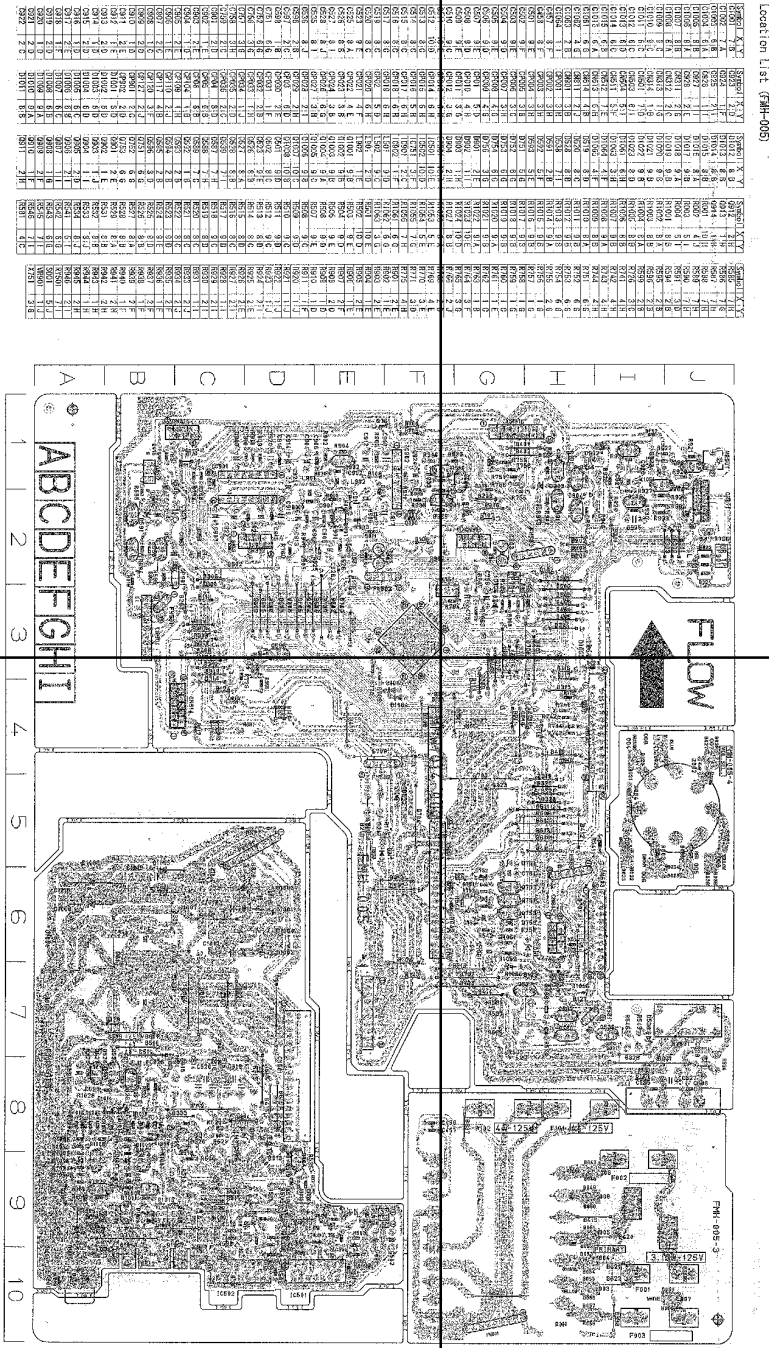

1-58

P1-66-a

Location List (FMH-005)

Location	Component	Quantity	Location	Component	Quantity	Location	Component	Quantity
B22	3-124	1	F3	3-124	1	J1	3-124	1
B22	3-124	1	F3	3-124	1	J2	3-124	1
B22	3-124	1	F3	3-124	1	J3	3-124	1
B22	3-124	1	F3	3-124	1	J4	3-124	1
B22	3-124	1	F3	3-124	1	J5	3-124	1
B22	3-124	1	F3	3-124	1	J6	3-124	1
B22	3-124	1	F3	3-124	1	J7	3-124	1
B22	3-124	1	F3	3-124	1	J8	3-124	1
B22	3-124	1	F3	3-124	1	J9	3-124	1
B22	3-124	1	F3	3-124	1	J10	3-124	1
B22	3-124	1	F3	3-124	1	J11	3-124	1
B22	3-124	1	F3	3-124	1	J12	3-124	1
B22	3-124	1	F3	3-124	1	J13	3-124	1
B22	3-124	1	F3	3-124	1	J14	3-124	1
B22	3-124	1	F3	3-124	1	J15	3-124	1
B22	3-124	1	F3	3-124	1	J16	3-124	1
B22	3-124	1	F3	3-124	1	J17	3-124	1
B22	3-124	1	F3	3-124	1	J18	3-124	1
B22	3-124	1	F3	3-124	1	J19	3-124	1
B22	3-124	1	F3	3-124	1	J20	3-124	1
B22	3-124	1	F3	3-124	1	J21	3-124	1
B22	3-124	1	F3	3-124	1	J22	3-124	1
B22	3-124	1	F3	3-124	1	J23	3-124	1
B22	3-124	1	F3	3-124	1	J24	3-124	1
B22	3-124	1	F3	3-124	1	J25	3-124	1
B22	3-124	1	F3	3-124	1	J26	3-124	1
B22	3-124	1	F3	3-124	1	J27	3-124	1
B22	3-124	1	F3	3-124	1	J28	3-124	1
B22	3-124	1	F3	3-124	1	J29	3-124	1
B22	3-124	1	F3	3-124	1	J30	3-124	1

P1-66-c

P1-66-d

C510	9 C	CP012	3 G	D904	2 H	R1027	8 B	R766	2 J
C511	10 E	CP013	6 H	EP501	10 A	R1028	8 A	R768	2 D
C512	10 D	CP014	6 H	IC501	10 E	R1053	5 E	R769	4 E
C513	8 C	CP015	6 H	IC502	10 D	R1054	5 E	R770	3 E
C514	8 C	CP016	5 H	IC751	3 F	R1055	7 G	R771	3 D
C515	8 C	CP017	6 H	IC901	2 C	R1056	7 H	R775	4 H
C516	8 C	CP018	6 H	IC902	1 F	R1061	6 G	R901	2 E
C517	8 C	CP019	6 H	L501	9 D	R1062	6 G	R902	2 E
C519	8 C	CP02	5 D	L502	9 C	R1063	3 G	R903	2 E
C520	8 C	CP020	6 H	L901	2 D	R501	10 E	R904	1 E
C523	9 A	CP021	4 F	L902	1 E	R502	10 D	R905	2 E
C525	8 A	CP022	4 E	Q1001	9 B	R503	9 E	R906	1 E
C526	8 B	CP023	3 B	Q1002	9 B	R504	9 D	R907	2 F
C527	8 B	CP024	3 B	Q1003	9 B	R505	9 E	R908	2 D
C528	8 J	CP026	6 G	Q1004	9 A	R506	9 D	R909	1 D
C535	8 I	CP027	3 H	Q1005	9 C	R507	9 E	R910	1 D
C536	8 J	CP028	2 I	Q1006	9 B	R508	9 C	R911	1 F
C596	2 B	CP029	2 H	Q1007	10 C	R509	9 D	R920	1 J
C597	2 C	CP03	6 D	Q1008	10 B	R510	9 C	R921	1 J
C598	1 B	CP030	2 E	Q501	9 D	R511	9 D	R922	1 J
C751	6 G	CP031	1 F	Q502	8 C	R512	9 C	R923	1 J
C752	6 G	CP032	2 B	Q523	9 E	R513	8 D	R924	2 I
C756	3 G	CP033	1 H	Q526	8 B	R514	8 C	R925	2 E
C757	3 G	CP034	1 J	Q527	8 A	R515	8 D	R926	2 E
C758	3 H	CP035	2 D	Q528	8 B	R516	8 C	R927	2 I
C759	2 C	CP036	2 C	Q539	7 I	R517	9 D	R928	1 I
C901	2 D	CP04	8 D	Q587	7 H	R518	9 C	R929	2 I
C902	1 E	CP05	6 B	Q588	7 H	R519	8 D	R930	2 I
C903	2 E	CP06	6 B	Q589	7 G	R520	8 C	R931	1 I
C904	1 D	CP104	1 B	Q592	1 B	R521	8 C	R933	2 J
C905	2 E	CP109	1 H	Q593	2 B	R522	8 C	R934	2 J
C906	1 E	CP117	4 B	Q594	2 B	R523	9 E	R935	2 F
C907	2 C	CP120	3 F	Q595	2 B	R524	9 E	R936	1 F
C908	1 C	CP127	2 J	Q596	3 D	R525	9 D	R937	2 F
C909	2 D	CP901	2 C	Q751	6 G	R526	8 B	R938	1 F
C910	1 D	CP902	2 D	Q752	6 G	R527	8 A	R939	2 F
C911	2 E	DI001	6 D	Q753	6 G	R528	8 B	R940	1 F
C912	1 E	DI002	6 D	Q901	2 E	R529	8 A	R941	2 H
C913	2 D	DI003	6 D	Q902	1 E	R531	8 B	R942	2 H
C914	1 D	DI004	6 D	Q903	1 J	R532	8 B	R943	1 H
C915	2 D	DI004	6 D	Q904	1 I	R533	8 J	R944	1 H
C916	1 D	DI005	6 C	Q905	2 D	R534	8 J	R945	2 H
C917	2 E	DI006	6 B	Q906	2 I	R541	5 I	R946	2 I
C918	1 F	DI007	6 C	Q907	1 I	R542	6 G	R9501	7 I
C919	2 D	DI008	6 B	Q908	1 G	R543	6 G	S001	5 J
C920	1 D	DI009	9 A	Q909	2 F	R545	7 I	VR901	1 J
C921	2 D	DI010	9 A	Q910	1 F	R546	7 I	X751	3 G
C922	2 C	DI011	8 B	Q911	2 H	R581	4 C		

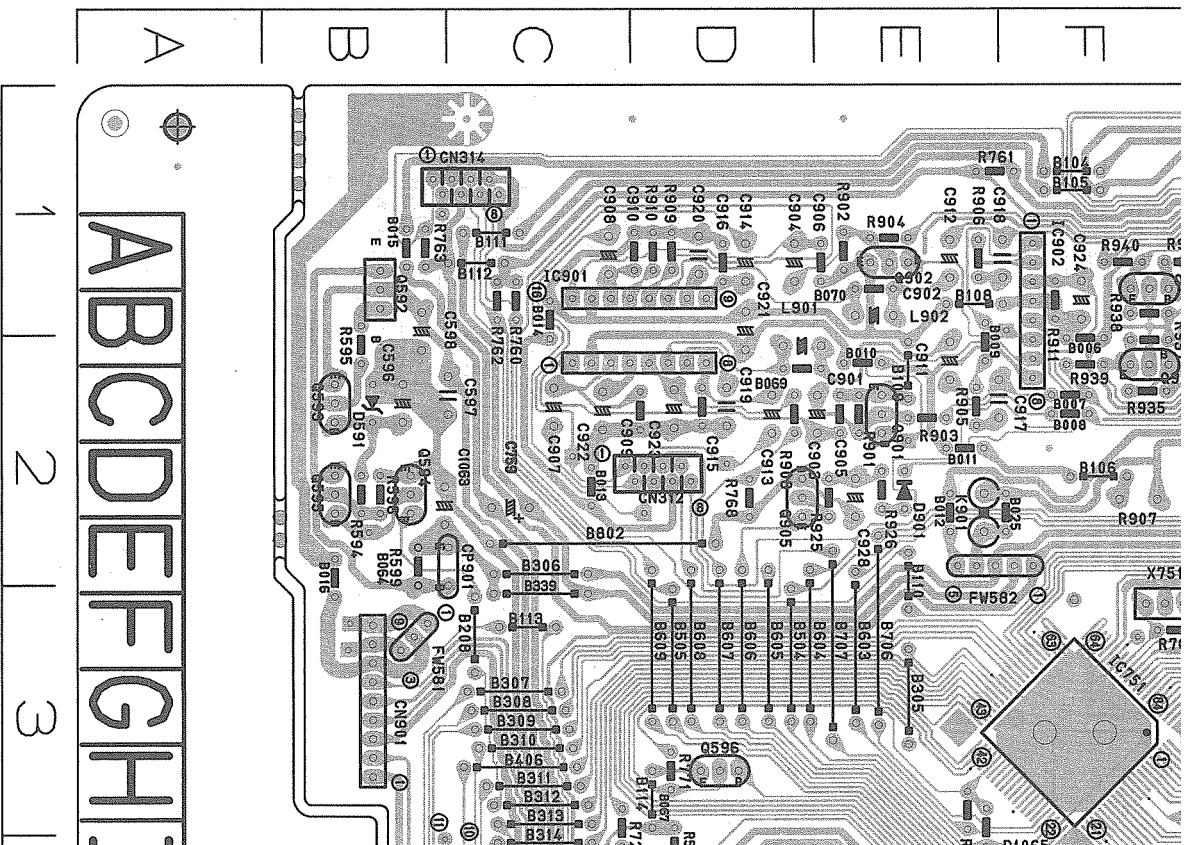

DECK/CD CONTROL / POWER SUPPLY SECTION (FMH-005)

Location List (FMH-005)

Symbol	X	Y	Symbol	X	Y	Symbol	X	Y	Symbol	X	Y	Symbol	X	Y
C1001	7	B	G923	2	D	D1012	8	B	Q912	2	H	R385	7	H
C1002	7	A	G924	1	F	D1013	8	B	Q913	1	H	R386	7	G
C1003	6	B	G925	2	I	D1014	8	B	Q914	1	H	R387	7	H
C1004	6	A	G926	1	I	D1015	8	B	R001	10	H	R388	7	H
C1005	8	B	G927	1	I	D1016	8	B	R002	4	J	R389	7	H
C1006	8	A	G928	2	E	D1017	8	A	R003	5	I	R390	7	H
C1007	8	B	G931	2	G	D1018	9	A	R004	5	I	R391	3	D
C1008	8	A	G932	2	C	D1019	9	B	R1001	8	B	R394	2	B
C1009	9	C	G933	1	G	D1020	9	B	R1002	8	A	R395	2	B
C1010	9	C	G934	1	B	D1021	9	B	R1003	8	B	R396	2	B
C1011	6	C	G950	7	D	D1022	9	B	R1004	8	A	R399	2	B
C1012	6	C	G953	6	I	D1023	8	D	R1005	8	B	R726	3	C
C1013	6	D	G954	5	I	D1024	8	D	R1006	8	B	R741	4	H
C1014	6	C	G951	5	F	D1063	3	H	R1007	9	B	R742	4	H
C1015	6	B	G952	7	E	D1064	4	F	R1008	9	A	R743	4	H
C1016	6	A	G963	6	H	D1065	4	F	R1009	8	B	R744	4	H
C1061	6	G	G964	4	B	D519	8	D	R1010	8	A	R751	6	G
C1062	4	G	G981	2	J	D520	8	C	R1011	9	B	R752	6	G
C1063	2	B	G990	3	B	D528	8	B	R1012	9	B	R753	6	G
C1064	1	I	G991	3	H	D538	7	I	R1013	9	B	R754	6	G
C457	8	F	CP002	3	H	D591	2	B	R1014	9	A	R755	2	G
C458	8	F	CP003	3	H	D592	5	F	R1015	9	B	R756	1	G
C501	9	E	CP004	3	H	D593	5	E	R1016	9	B	R757	1	G
C502	9	F	CP005	3	G	D751	5	G	R1017	9	B	R758	1	G
C503	9	E	CP006	3	G	D752	6	G	R1018	9	B	R759	1	G
C504	9	D	CP007	3	H	D753	6	G	R1019	9	B	R760	1	G
C505	9	E	CP008	4	G	D754	6	G	R1020	9	A	R761	1	E
C506	9	D	CP009	4	G	D756	3	G	R1021	9	B	R762	1	C
C507	9	E	CP01	5	D	D901	2	E	R1022	9	A	R763	1	B
C508	9	D	CP010	4	H	D902	1	I	R1023	10	E	R764	3	F
C509	9	E	CP011	3	G	D903	1	H	R1024	10	D	R765	3	G
C510	9	C	CP012	3	G	D904	2	H	R1027	8	B	R766	2	J
C511	10	E	CP013	6	H	EP501	10	A	R1028	8	A	R768	2	D
C512	10	D	CP014	6	H	TC501	10	E	R1053	5	E	R769	4	E

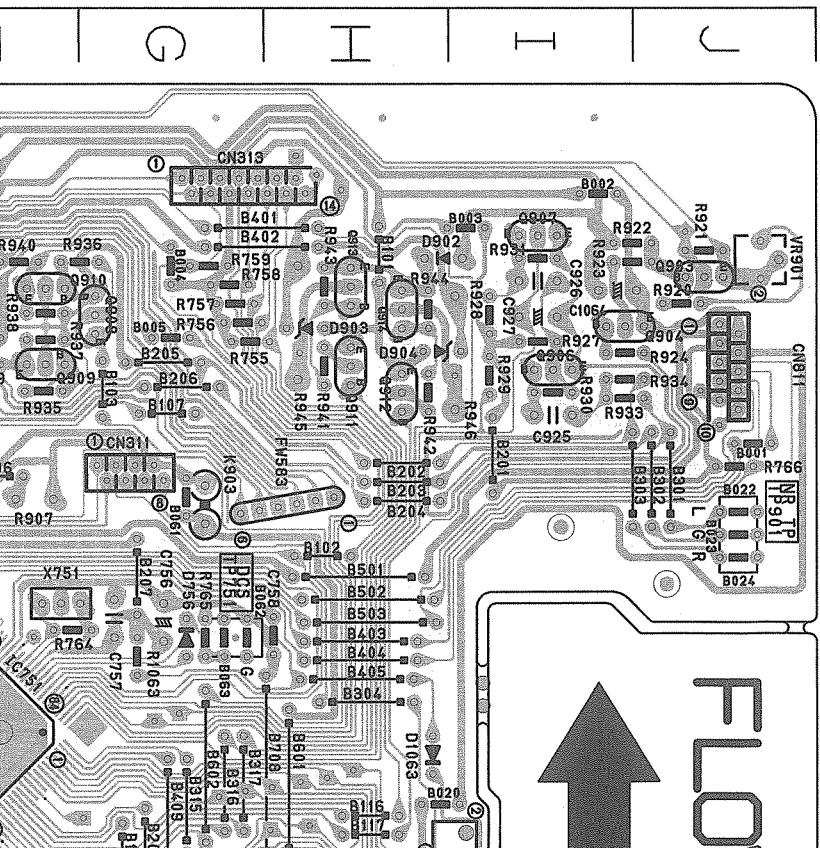

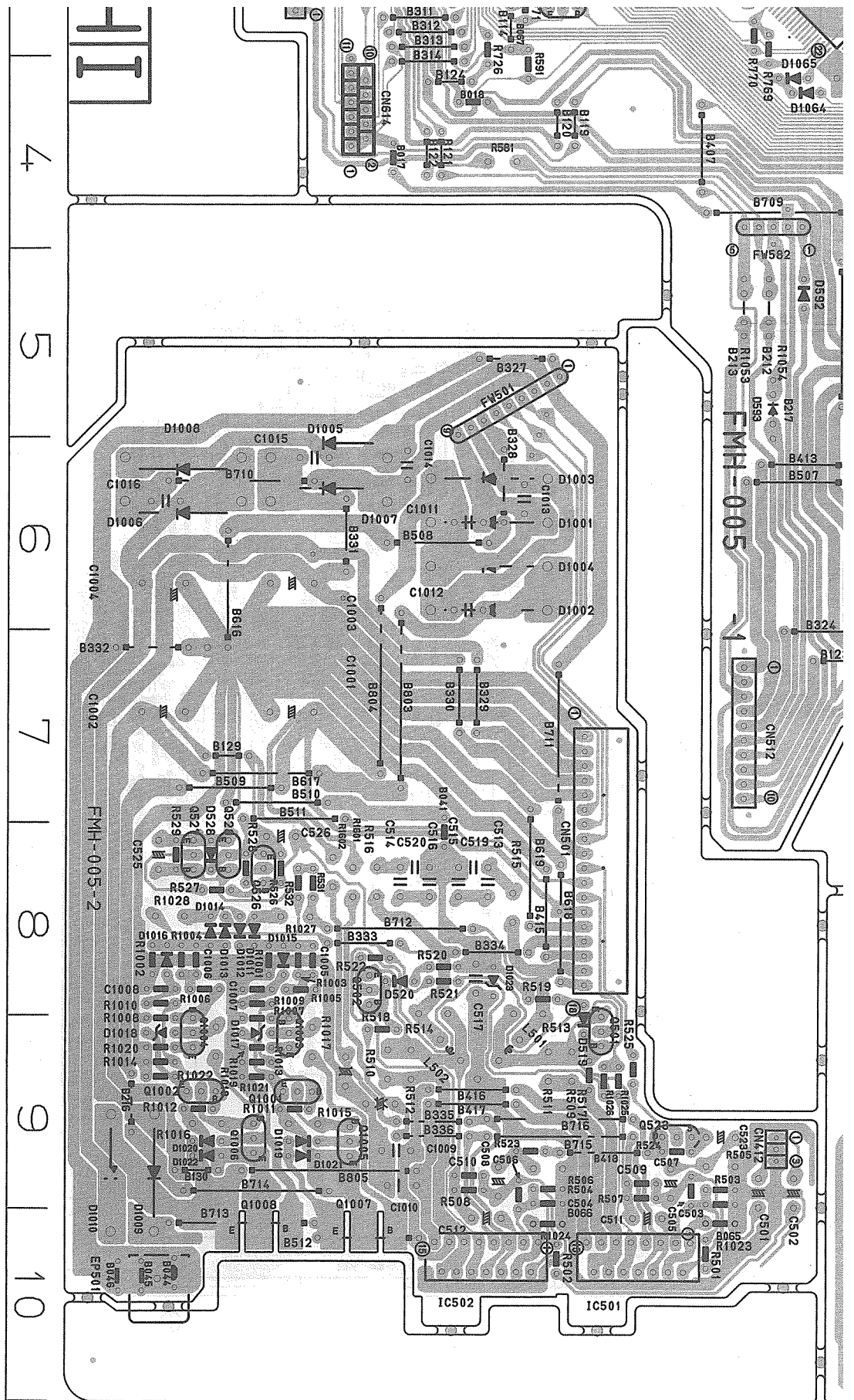

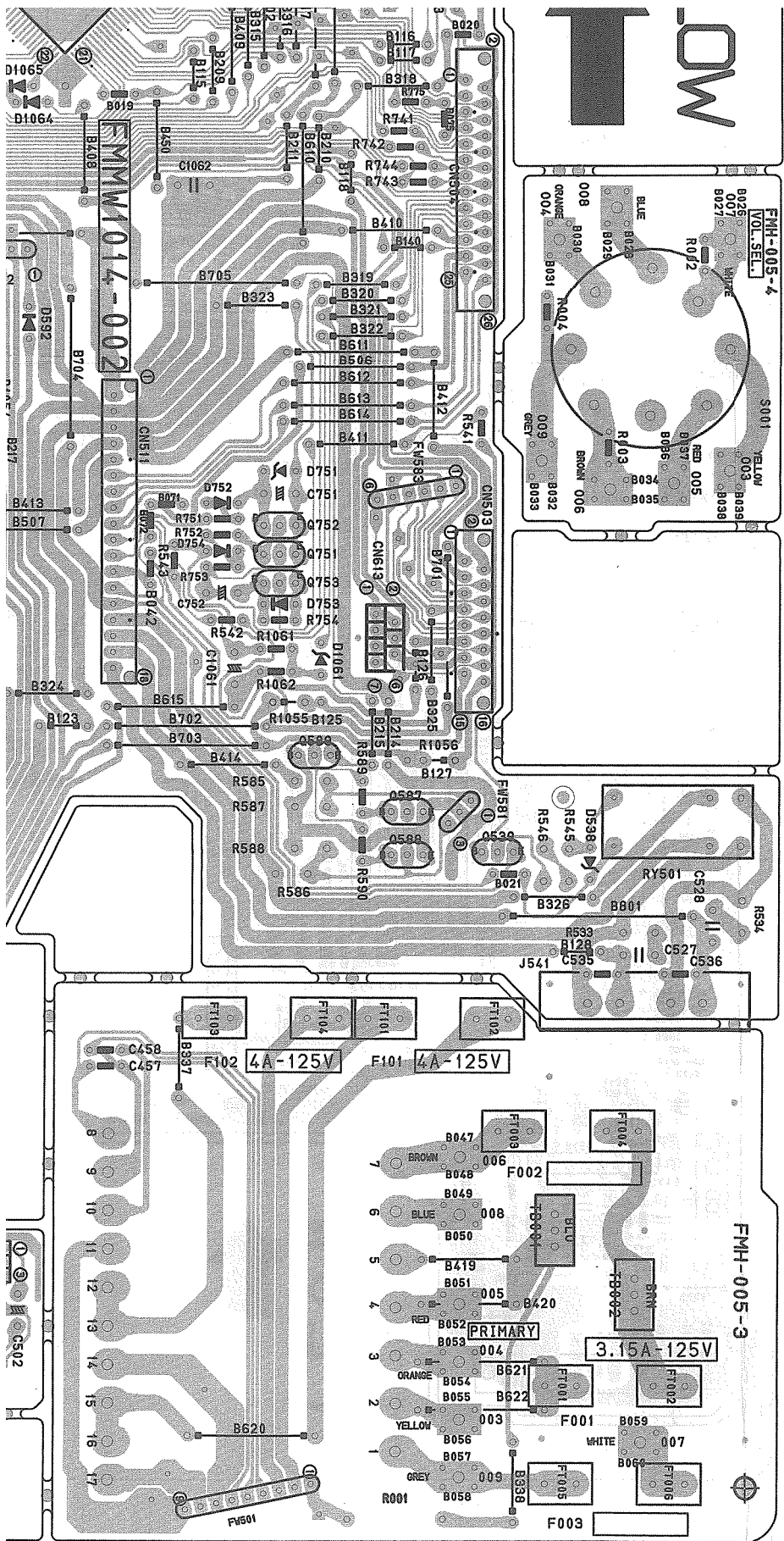



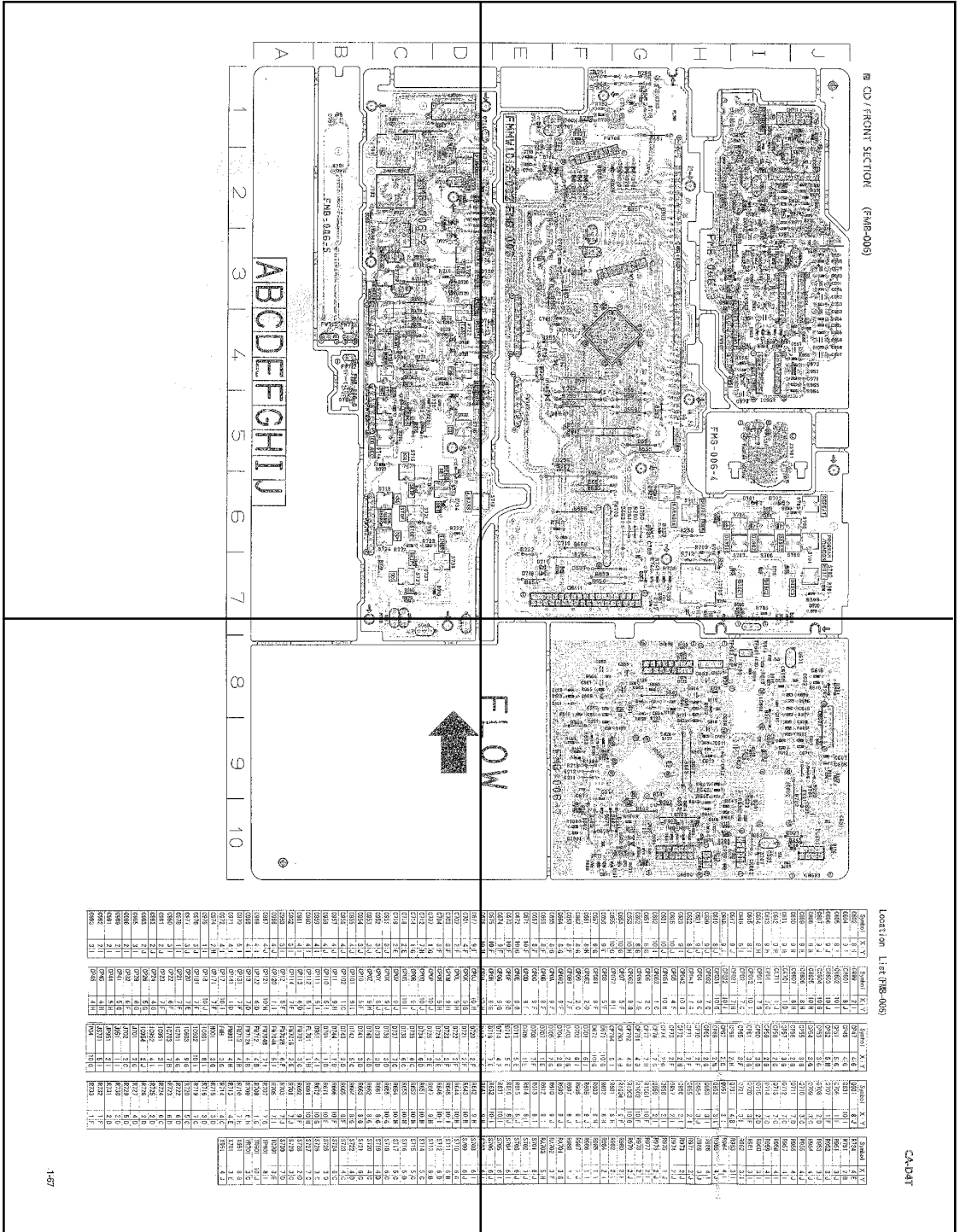

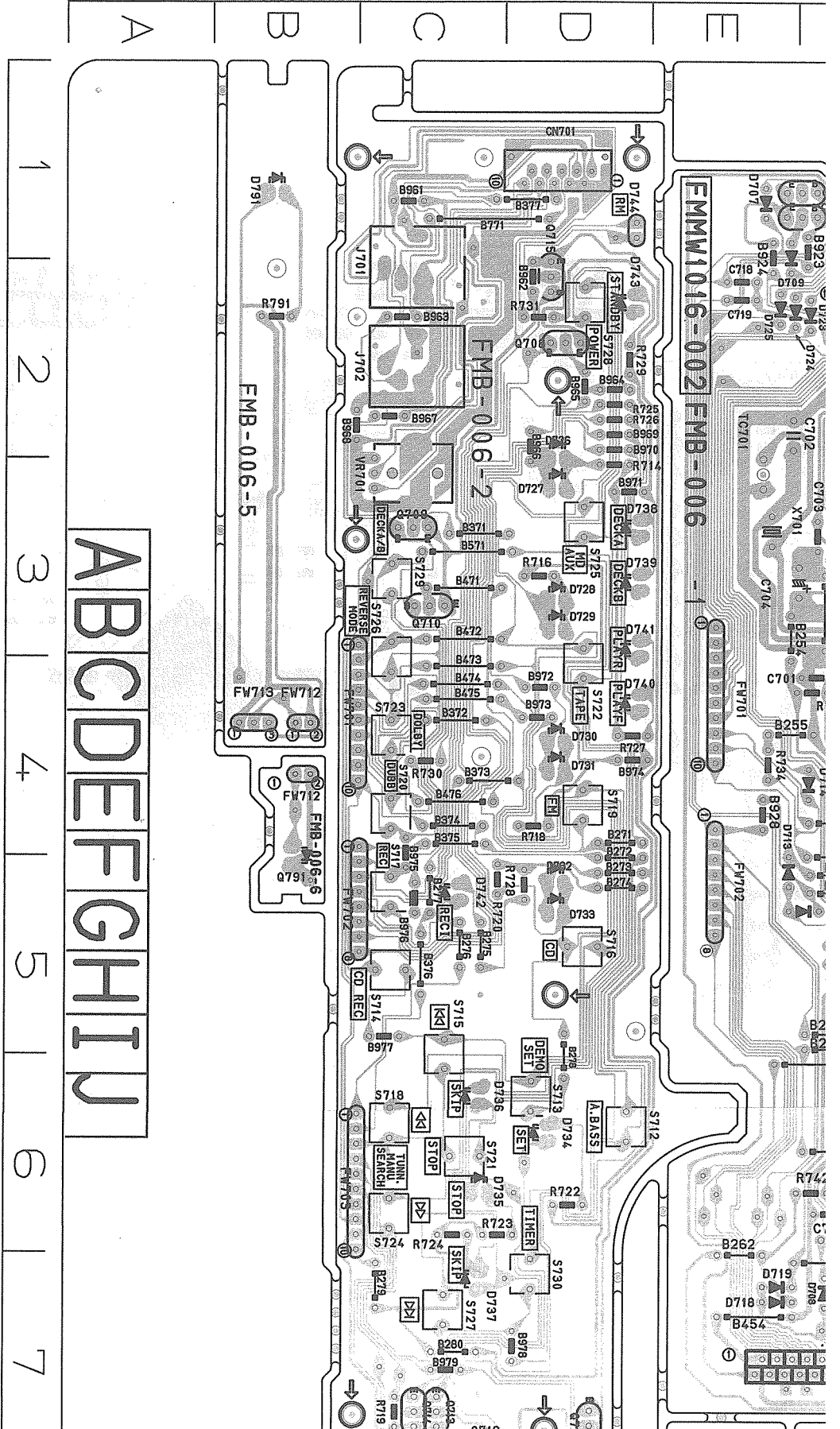

ABCDEFGHIJ



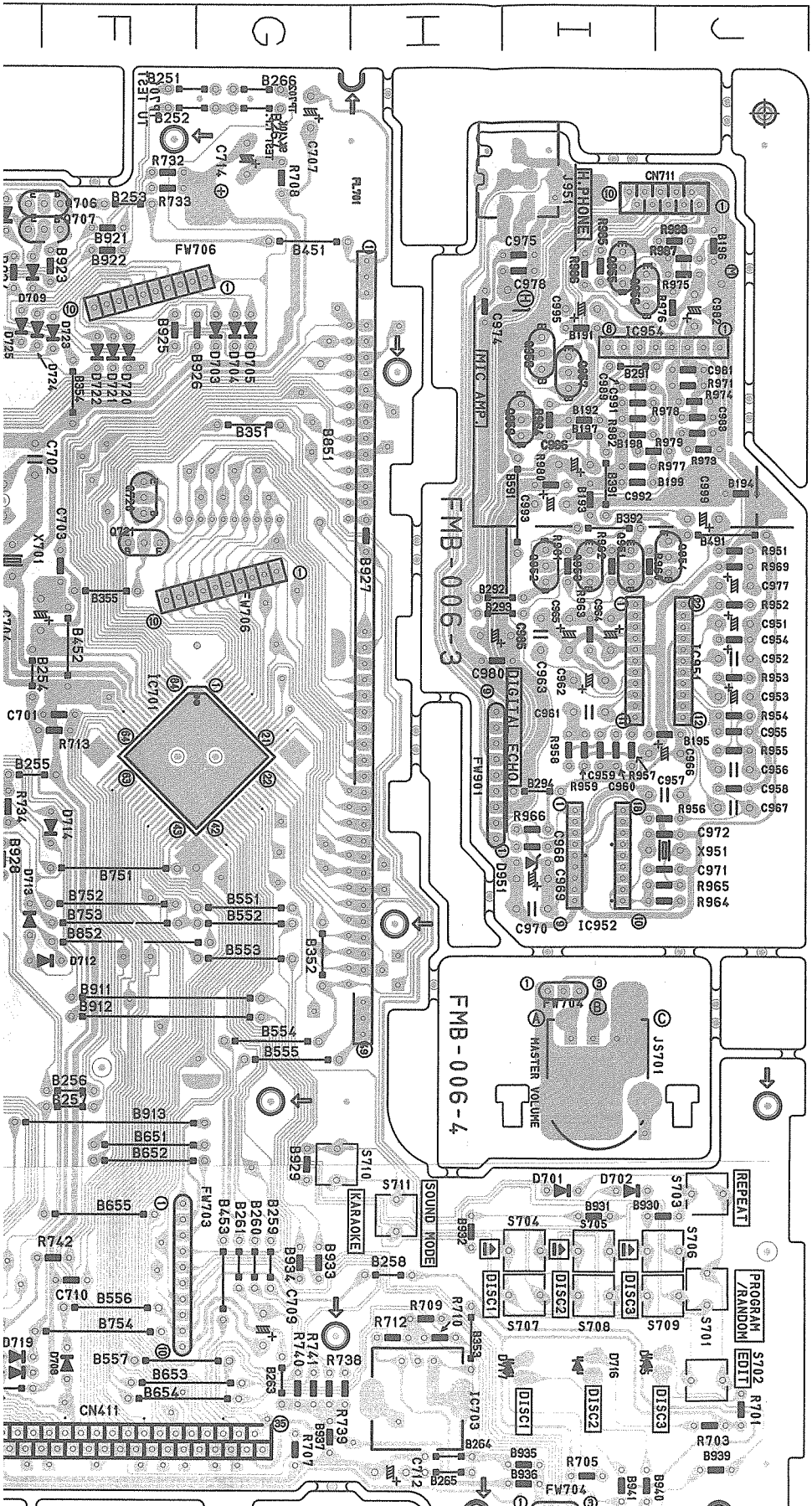

CD / FRONT SECTION (FMB-006)

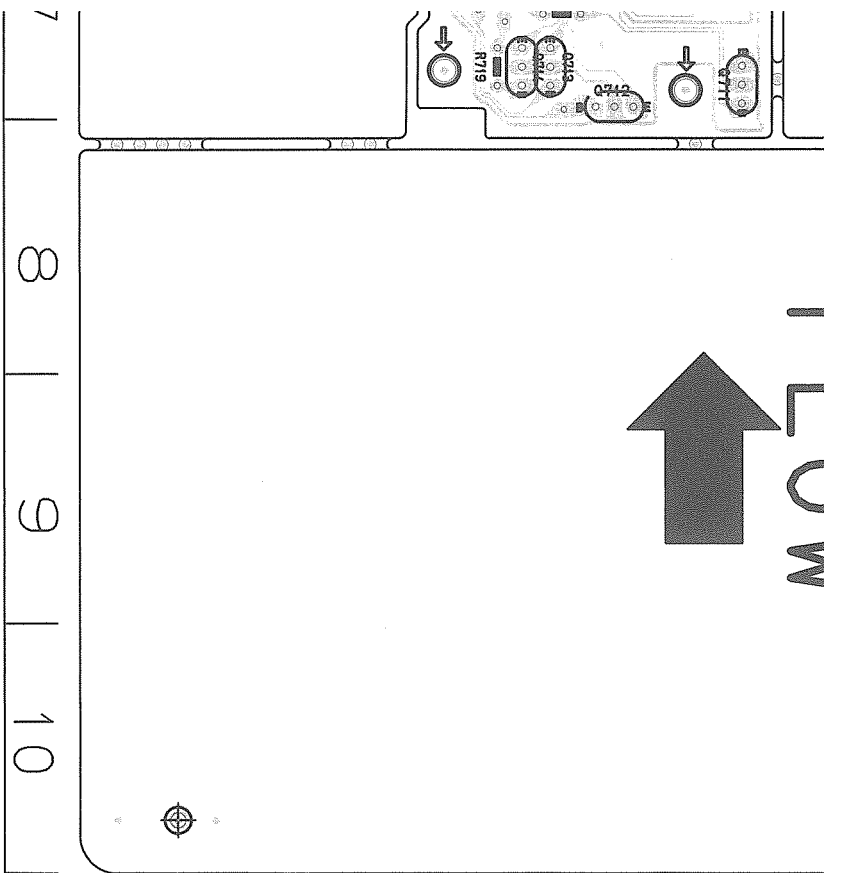

C676	10 H	CP01	10 H	D718	7 E	R632	10 I	S706	6 J
C677	9 F	CP0J	10 H	D719	7 E	R641	9 H	S707	6 I
C701	4 F	CP0K	9 G	D720	2 F	R642	9 H	S708	6 I
C702	2 E	CP0L	9 H	D721	2 F	R643	10 H	S709	6 J
C703	3 F	CP0M	9 H	D722	2 F	R644	10 H	S710	6 G
C704	3 F	CP0N	9 H	D723	2 F	R645	10 I	S711	6 H
C707	1 G	CP0P	10 J	D724	2 E	R646	10 I	S712	6 D
C712	7 H	CP0Q	10 J	D725	2 E	R647	9 H	S713	6 D
C714	1 G	CP0R	9 J	D734	6 D	R651	10 H	S714	5 C
C718	2 E	CP0S	10 I	D735	6 C	R652	10 H	S715	5 C
C719	2 E	CP0V	9 J	D736	6 C	R653	10 H	S716	5 D
C951	3 J	CP0X	9 J	D737	7 C	R654	10 H	S717	5 C
C952	3 J	CP0Y	8 J	D738	3 D	R655	10 G	S718	6 C
C953	3 J	CP0Z	9 H	D739	3 D	R661	8 G	S719	4 D
C954	3 J	CP10	5 F	D740	4 D	R662	8 G	S720	4 C
C955	4 J	CP101	9 I	D741	3 D	R663	8 G	S721	6 C
C956	4 J	CP102	1 C	D742	5 C	R664	8 G	S722	4 D
C957	4 J	CP11	9 H	D743	2 D	R665	8 F	S723	4 C
C958	4 J	CP110	5 I	D744	1 D	R666	10 F	S724	6 C
C959	4 I	CP111	5 I	D791	1 B	R671	10 F	S725	3 D
C960	4 I	CP112	5 I	D951	4 I	R672	10 G	S726	3 C
C961	4 I	CP113	6 D	FL701	1 H	R691	10 H	S727	7 C
C962	3 I	CP114	7 F	FW701	3 C	R692	9 F	S728	2 D
C963	3 I	CP12	5 F	FW701B	3 E	R701	7 J	S729	3 C
C966	4 J	CP120	1 I	FW702B	6 F	R703	7 J	S730	7 D
C967	4 J	CP121	10 H	FW704A	5 I	R705	7 I	TC701	3 E
C968	4 I	CP122	6 D	FW704B	7 I	R707	7 G	TP601	8 I
C970	5 I	CP13	7 D	FW712	4 B	R708	1 G	TW601	10 J
C971	4 I	CP131	7 F	FW712A	4 B	R709	6 H	VR701	3 C
C972	4 I	CP141	1 D	FW713	4 B	R710	7 H	X651	8 G
C974	2 H	CP171	7 F	FW901	4 H	R713	4 E	X701	3 E
C975	1 I	CP18	10 J	FWB	3 G	R714	4 C	X951	4 J
C976	3 J	CP181	7 F	H001	3 G	R715	3 D		
C977	3 J	CP20	7 E	I0601	8 I	R716	3 D		
C978	1 I	CP21	7 F	I0602	10 I	R719	7 C		
C980	3 I	CP22	6 F	I0603	9 G	R720	5 C		
C981	2 J	CP23	7 F	I0701	4 G	R722	6 D		
C982	2 J	CP24	4 G	I0703	7 H	R723	6 D		
C983	2 J	CP26	5 G	I0951	3 I	R724	6 C		
C985	3 I	CP28	6 G	I0952	4 I	R725	2 D		
C986	2 I	CP32	6 F	I0954	2 J	R726	2 D		
C989	2 I	CP41	5 G	J701	2 C	R727	4 D		
C991	2 I	CP44	5 H	J951	1 I	R729	5 D		
C992	2 I	CP45	4 H	JP951	2 I	R730	2 D		
C993	3 I	CP46	4 H	JS701	5 I	R731	2 D		
				P04	10 G	R732	1 F		
						R733	1 F		

Location List (FMB-006)

Symbol	X	Y	Symbol	X	Y	Symbol	X	Y	Symbol	X	Y	Symbol	X	Y
G602	8	H	G999	2	I	GP47	4	G	G601	8	J	R734	4	E
G604	9	I	GM601	8	J	GP49	4	G	G603	10	I	R791	2	B
G605	8	I	GM602	10	I	GP51	5	G	G606	7	J	R951	3	J
G606	9	J	GM603	10	J	GP52	5	H	G607	9	J	R952	3	J
G607	9	J	GM604	10	G	GP53	3	G	G608	8	H	R953	3	J
G608	8	H	GM605	10	H	GP54	3	G	G609	9	H	R954	4	J
G609	9	H	GM606	8	H	GP55	3	G	G610	9	H	R955	4	J
G610	9	H	GM607	8	H	GP56	2	G	G611	9	H	R956	4	J
G611	9	H	GM701	1	D	GP57	3	G	G612	9	H	R957	4	I
G612	9	H	GN711	1	J	GP58	2	G	G613	9	H	R958	4	I
G613	9	H	GP01	7	C	GP59	2	G	G614	8	H	R959	4	I
G614	8	H	GP011	7	G	GP60	3	G	G615	8	H	R960	3	I
G615	8	I	GP012	10	I	GP61	3	G	G616	8	I	R961	3	I
G616	8	I	GP02	7	C	GP65	3	F	G617	9	J	R962	3	I
G617	9	J	GP021	7	H	GP66	2	H	G618	9	I	R963	3	I
G618	9	I	GP022	10	I	GP67	2	G	G619	8	J	R964	4	I
G619	8	J	GP031	10	G	GP68	2	H	G620	9	J	R965	4	J
G620	9	J	GP032	7	G	GP69	2	G	G621	9	J	R966	4	I
G621	9	J	GP04	3	C	GP70	2	F	G622	8	J	R969	3	J
G622	8	J	GP041	7	G	GP71	2	F	G623	9	I	R971	2	J
G623	9	I	GP042	10	G	GP72	2	H	G624	9	I	R973	2	J
G625	10	J	GP05	4	F	GP73	2	F	G625	10	J	R974	2	J
G631	10	J	GP051	10	H	GP74	2	G	G632	10	I	R975	1	J
G632	10	I	GP052	1	C	GP76	2	G	G633	10	I	R976	2	J
G651	8	G	GP06	2	C	GP77	7	H	G655	10	G	R977	2	I
G652	8	G	GP061	7	G	GP791	4	B	G654	10	G	R978	2	I
G653	10	H	GP062	8	G	GP792	4	B	G655	10	G	R979	2	J
G654	10	G	GP07	5	F	GP793	4	B	G656	9	F	R980	2	I
G655	10	G	GP072	8	I	GP794	6	I	G657	9	F	R982	2	I
G656	9	F	GP08	5	F	D671	10	G	G658	8	H	R984	2	I
G657	9	G	GP081	9	F	D672	10	G	G659	8	H	R985	1	I
G661	8	H	GP082	2	D	D701	6	I	G662	8	G	R986	1	I
G662	8	G	GP09	2	C	D702	6	I	G663	8	F	R987	1	J
G663	8	F	GP091	7	F	D703	2	G	G664	8	G	R988	1	J
G664	8	G	GP092	9	F	D704	2	G	G665	8	G	RA701	3	G
G665	8	G	GP0A	9	F	D705	2	G	G666	8	F	RA702	3	F
G666	8	F	GP0B	9	F	D707	1	E	G667	8	F	RA703	5	H
G667	8	F	GP0C	9	F	D708	7	F	G671	10	F	S701	6	J
G671	10	F	GP0D	9	F	D709	1	E	G672	10	G	S702	7	J
G672	10	G	GP0E	9	G	D712	5	E	G673	10	F	S703	6	J
G673	10	F	GP0F	9	G	D713	5	E	G674	9	F	S704	6	I
G674	9	F	GP0G	9	G	D714	4	F	G675	10	F	S705	6	I
G675	10	F	GP0H	9	G	D718	7	E	G676	10	H	S706	6	J
G676	10	H	GP0I	10	H	D719	7	E	G677	9	F	S707	6	I
G677	9	F	GP0J	10	H	D720	2	F				S708	6	I

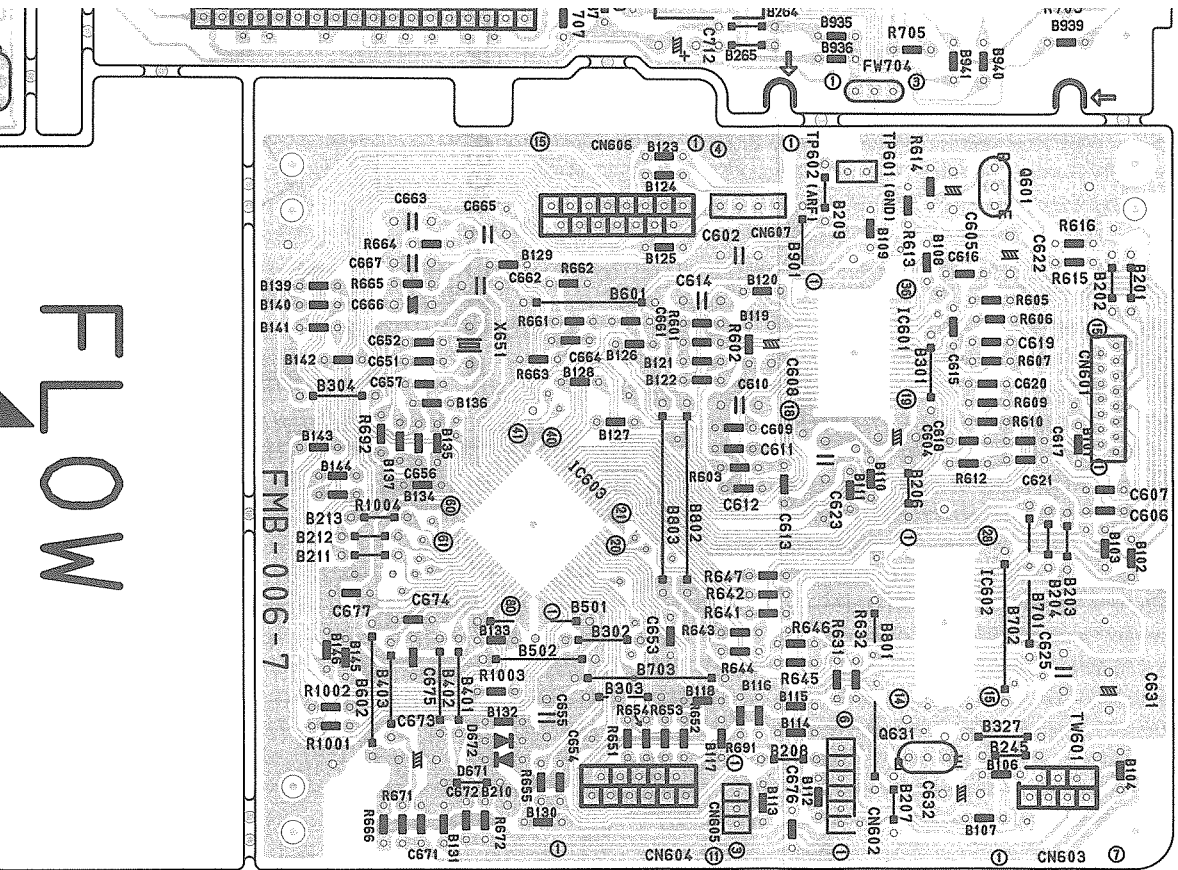

FLOW



P1-68-a

P1-68-b

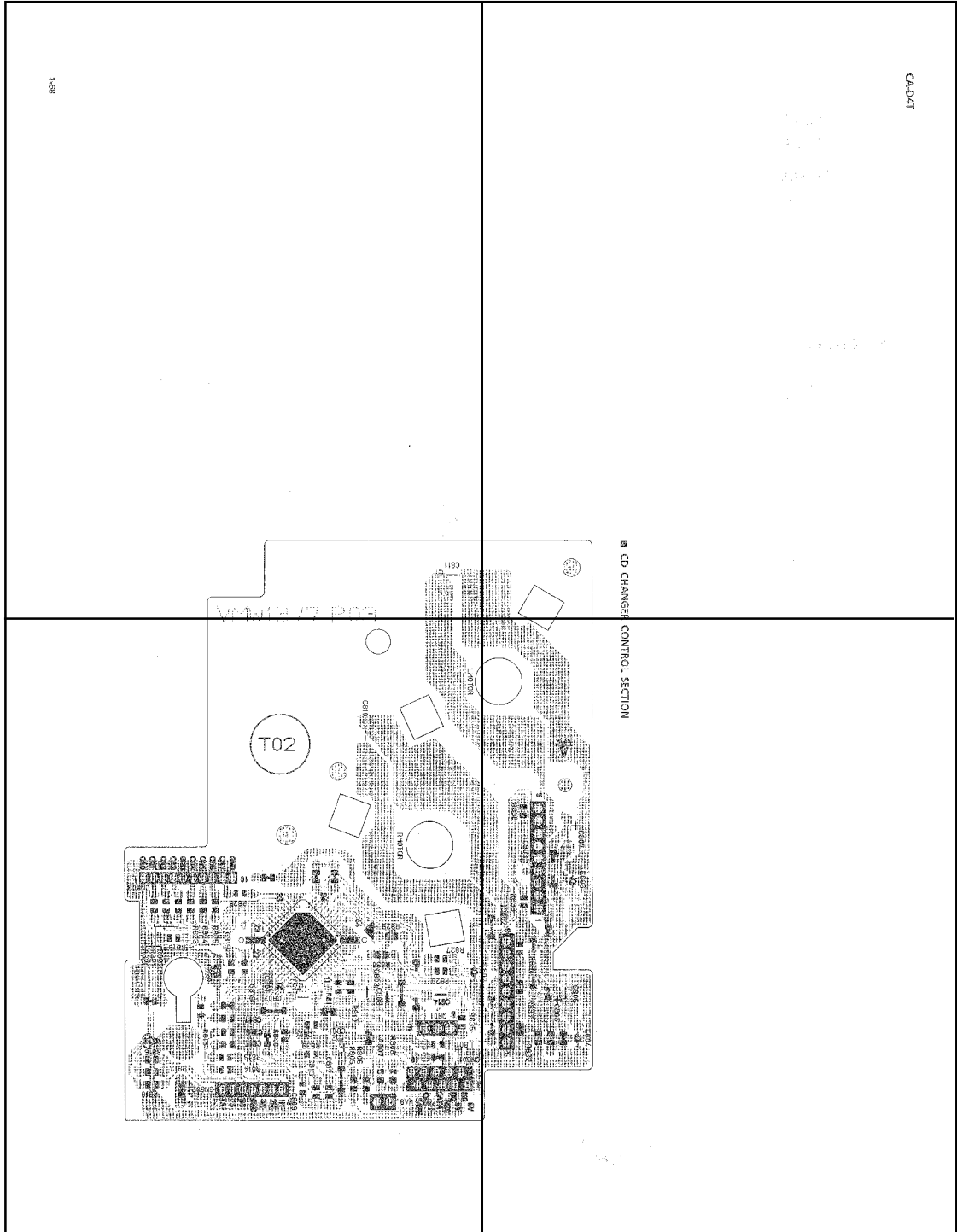

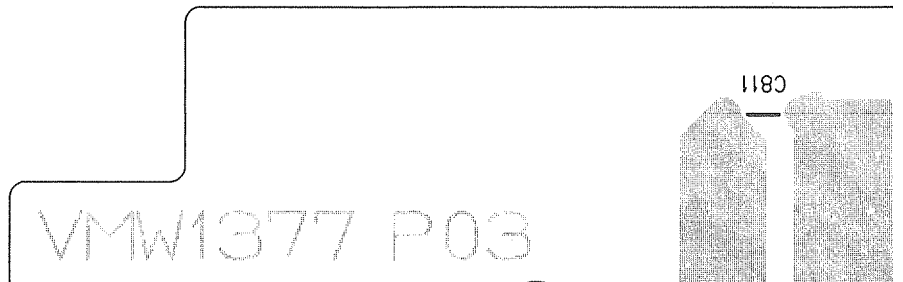

CA-D4T

3/20/2023  
11:11 AM  
00:00

3/20/2023

■ CD CHANGER C

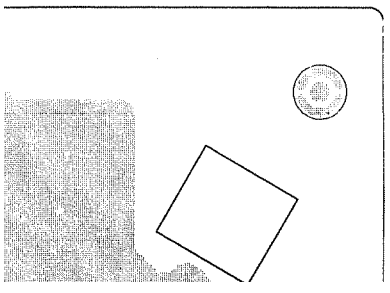

VMW1377 P03

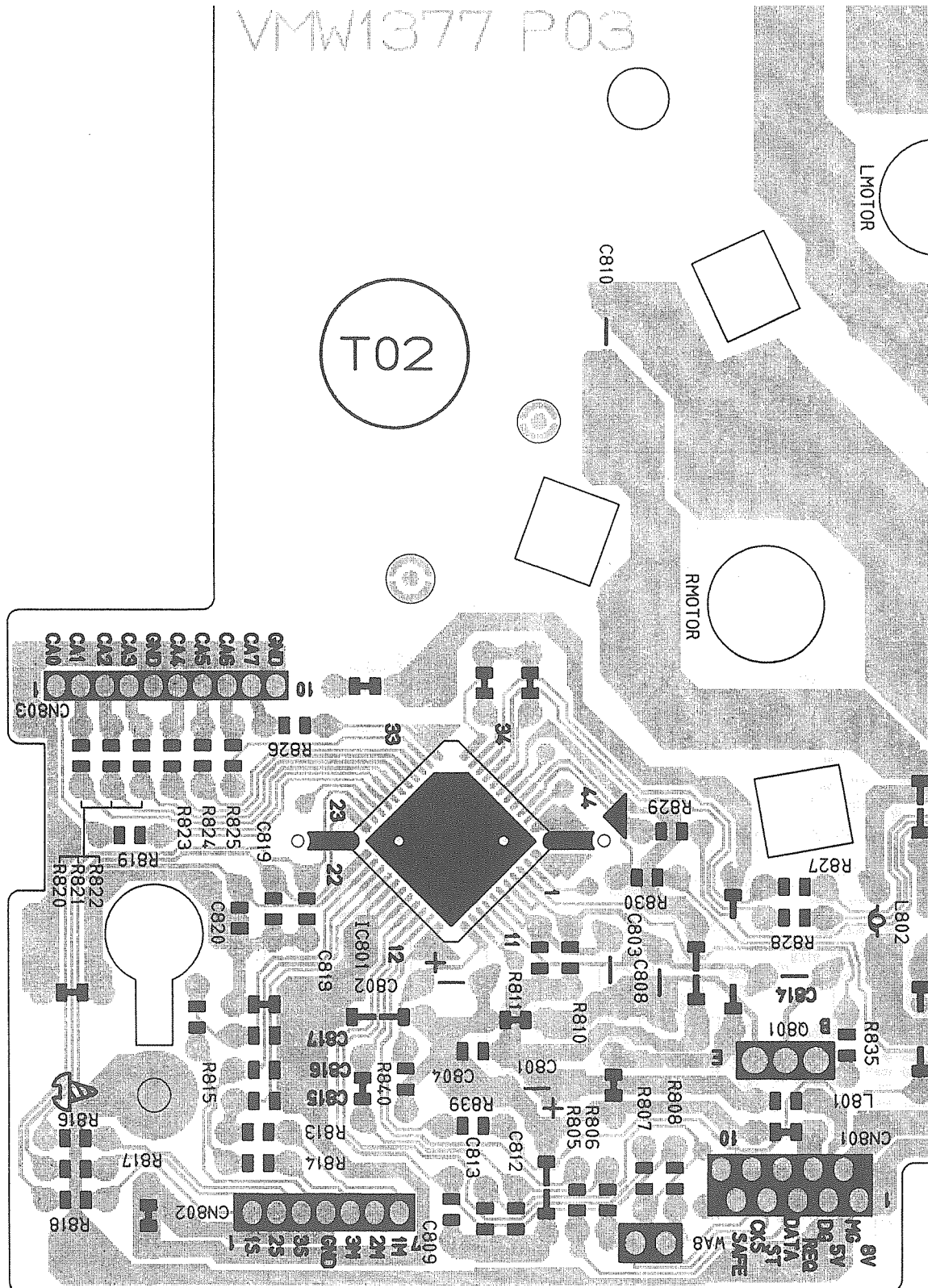



3ER CONTROL SECTION

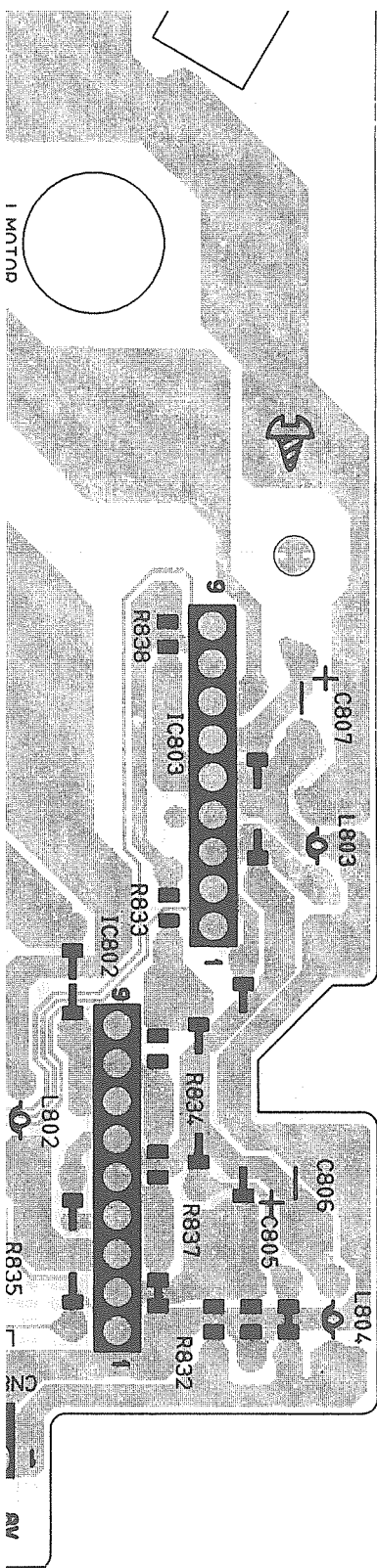



# PARTS LIST

※ All printed circuit boards and its assemblies are not available as service parts.

## – Contents –

General Exploded View and Parts List .....	2-2
Changer Mechanism Ass'y and Parts List .....	2-6
■ Grease Point .....	2-6
CD Mechanism Ass'y and Parts List .....	2-8
■ Grease Point .....	2-8
Cassette Mechanism Ass'y and Parts List .....	2-9
■ Grease Point .....	2-9
Electrical Parts List .....	2-12
■ CD/Deck Control & Power Supply P. C. Board Ass'y (FMH-005) .....	2-12
■ Deck/Tuner & Source Select P. C. Board Ass'y (FMC-002) .....	2-16
■ CD Selection P. C. Board Ass'y (FMB-006) .....	2-22
■ Changer Control P. C. Board Ass'y .....	2-26
Accessories List .....	2-27
Packing Materials and Part Numbers .....	2-28

# General Exploded View and Parts List

Block No. 

M	1	M	M
---	---	---	---

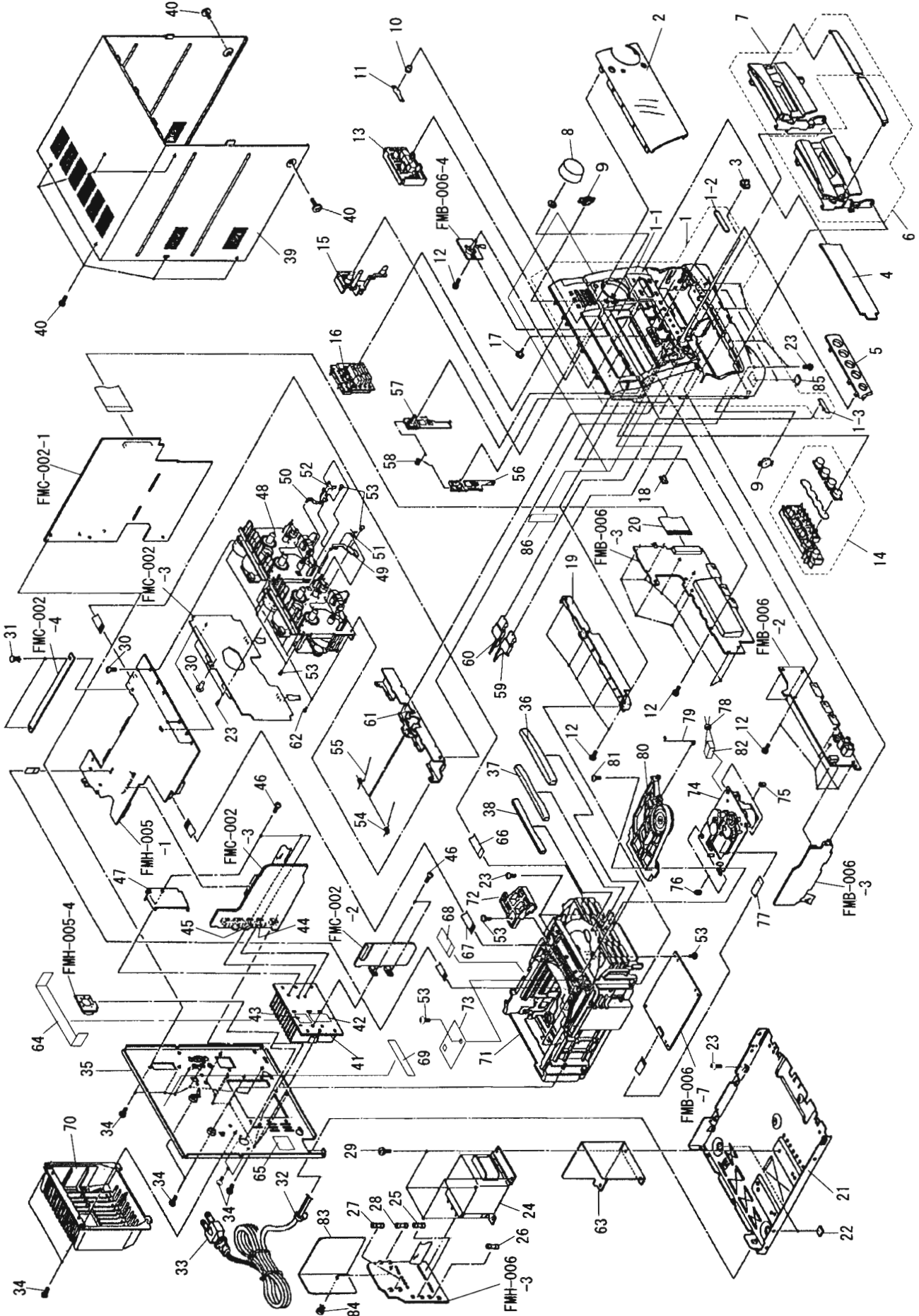

Block No. 

M	1	M	M
---	---	---	---

## Parts List

Item	Part Number	Part Name	Q'ty	Description	Area	
1	EFP-CAD4TE(S)	FRONT PANEL ASSY	1		Except U,UB,US,UP and UT	
	EFP-CAD4TU(S)	FRONT PANEL ASSY	1		U,UB,US,UP,UT	
	1-1	E103052-008SM	FRONT PANEL	1		Except U,UB,US,UP and UT
		E103052-014SM	FRONT PANEL	1		U,UB,US,UP,UT
	1-2	E309487-001SM	INDICATOR PLATE	1		
1-3	E406971-221	JVC MARK	1			
2	E208574-007SM	WINDOW SCREEN	1		Except U,UB,US,UP and UT	
	E208574-008SM	WINDOW SCREEN	1		U,UB,US,UP,UT	
	3	E408765-004SM	MIC KNOB	1		U,UB,US,UP,UT
	4	E309489-001	FL SCREEN	1		
5	E208576-001	ORNAMENT	1			
6	E208758-001SM	CASSETTE HOLDER ASSY	1			
7	E208759-001SM	CASSETTE HOLDER ASSY	1			
8	E309501-001	MAIN VOLUME KNOB	1			
9	VYH7779-00B	DAMPER	2			
10	E408733-001SM	REMOTE CONTROL WINDOW	1			
11	E408937-001SM	REMOTE CONTROL SCREEN	1			
12	SDSF2608Z	SCREW	23			
13	E208582-003	PUSH BUTTON	1	STOP		
14	E208757-002SM	PUSH BUTTON ASSY	1			
15	E208587-001	PUSH BUTTON	1	BASS		
16	E208578-001	PUSH BUTTON	1	3CD		
17	E408760-001SM	INDICATOR LENS	1	REC		
18	E408759-001SM	POWER INDICATOR	1			
19	E309495-002SM	STAY BRACKET	1			
20	VVWF1235-12TTBW	FLAT WIRE ASSY	1	FL to Input P.C.Board		
21	E102616-228SM	CHASSIS BASE	1			
22	E75896-006	FELT SPACER	2			
23	SBSG3008Z	TAPPING SCREW	9			
24	FMTP1100-01EA	POWER TRANSFORMER	1		A,EF,EN,G,GI,VX,BS	
25	FMTP1100-01FA	POWER TRANSFORMER	1		U,UB,US,UP,UT	
	FMTP1100-01JA	POWER TRANSFORMER	1		C,J	
	QMF0007-4R0J1	FUSE	1	F101(T4.0A/125V)	C,J	
	QMF51E2-3R15J1	FUSE	1	F101(T3.15A/250)	Except C,J	
26	QMF0007-4R0J1	FUSE	1	F102(T4.0A/125V)	C,J	
27	QMF51E2-3R15J1	FUSE	1	F102(T3.15A/250)	Except C,J	
	QMF0007-3R15J1	FUSE	1	F001(T3.15A/125V)	C,J	
	QMF51E2-1R2J1BS	FUSE	1	F001(T1.2A/250V)	BS	
	QMF51E2-1R25	FUSE	1	F001(T1.25A/250)	A,FF,EN,G,GI,VX	
	QMF51E2-2R5J1	FUSE	1	F002(T2.5A/250V)	U,UB,US,UP,UT	
-	FMND4004-001	FUSE LABEL	1	F001	A,BS,EF,EN,GI,G,VX	
-	VND4003-071	FUSE LABEL	1	F002	U,UB,UTS,UP,UT	
-	VND4003-083	FUSE LABEL	2	F101,F102	Except J,C	
28	QMF51E2-1R25	FUSE	1	F003(T1.25A/250)	U,UB,US,UP,UT	
29	E65389-002	SPECIAL SCREW	4			
30	SBST2604Z	SCREW	3			
31	E48729-021	PLASTIC RIVET	3			
32	QHS3876-162	CORD STOPPER	1			
33	EMP7000-200	POWER CORD	1		UP	
	QMP1480-200E	POWER CORD	1		C,J	
	QMP25F0-244	POWER CORD	1		A	
	QMP3900-200	POWER CORD	1		EF,EN,G,GI,US,VX	
	QMP5530-0085BS	POWER CORD	1		BS,UB	
	QMP7520-200	POWER CORD	1		U,UT	
34	E73273-003	SPECIAL SCREW	12		Except U,UB,UP,US and UT	

CA-D4T

△	Item	Part Number	Part Name	Q'ty	Description	Area
	35	E73273-003 E103054-022SM E103054-023SM E103054-024SM E103054-025SM	SPECIAL SCREW REAR PANEL REAR PANEL REAR PANEL REAR PANEL	14 1 1 1 1		U,UB,UP,US,UT J C U,UB,US,UT BS,EF,EN,G,GI
	35 36 37	E103054-026SM E103054-027SM E103054-028SM E208593-006SM E208595-006SM	REAR PANEL REAR PANEL REAR PANEL CD FITTING CD FITTING	1 1 1 1 1		A VX UP
	38 39 40 41	E208597-006SM FMKL1003-002 FMKL1003-003 SDSG3006M FMMH3003-006	CD FITTING METAL COVER METAL COVER TAPPING SCREW HEAT SINK	1 1 1 8 1		Except J,C J,C
	42 43 44 45 46	FMPK4003-001 FMPK4004-001 2SA1490LC(O,Y) 2SC3854LC(O,Y) SBSG3014CC	MICA SHEET MICA SHEET SI.TRANSISTOR SI.TRANSISTOR SCREW	1 1 1 1 5	Q1008 Q1007	
	47 48 49 50 51	FMKL4007-001 ----- E309477-222 E309478-222 E407801-002	HEAT SINK BRACKET CHASSETTE MECHANISM ASSY EJECT SAFETY EJECT SAFETY SPRING	1 1 1 1 1	SEE PAGE 2-9	
	52 53 54 55	E407802-002 SBSF3008Z SBSF3008Z E408933-001 E408934-001	SPRING TAPPING SCREW TAPPING SCREW HOLDER SPRING HOLDER SPRING	1 10 11 1 1		Except C,J C,J
	56 57 58 59 60	E309479-001SS E309480-001SS E408742-001SS E309496-001 E309497-001	EJECT LEVER EJECT LEVER SPRING EJECT BUTTOM EJECT BUTTOM	1 1 1 1 1		
	61 62 63 64 65	E208588-001 SBST3006Z E409015-001SM FMYSA110-001 E65507-001	HOLDER BKT TAPPING SCREW SHIELD PLATE SPACER CAUTION LABEL	1 4 1 1 1		C
△	66 67 68 69	E67199-001 VWF1210-30TTB VWF1211-22TTBV VWF1207-20TTB E406709-001	CAUTION LABEL FLAT WIRE ASSY FLAT WIRE ASSY FLAT WIRE ASSY CAUTION LABEL	1 1 1 1 1	Mecha to M-Com. CD to M-Com CD to AMP. P.C.Board.	J
	70 71 72 73	E207356-001SM E207356-002SM ----- E309662-001 FMKL4008-001	REAR COVER REAR COVER CHANGERMECHANISM ASSY DISC STOPPER LOD STOPPER	1 1 1 1 1	SEE PAGE 2-6	Except C,J C,J C,J
	74 75 76 77 78	----- FMYH4003-002 FMYH4003-001 VWF1015-09TTAV VYSA1R2-033	CD MECHANISM ASSY INSULATOR INSULATOR FLAT WIRE ASSY SPACER	1 2 2 1 1	SEE PAGE 2-8 Pick to Servo	

⚠	Item	Part Number	Part Name	Q'ty	Description	Area
	79	VKW5187-001	ROD	1	CD Mecha to Servo	
	80	VKS3703-00DMM	CLAMPER ASSY	1		
	81	SPST2606Z	TAPPING SCREW	1		
	82	VDM1001-M001A	SOCKET WIRE ASSY	1		
	83	E409190-221SM	PROTECT SHEET	1		
	84	E48729-021	RIVET	1		
	85	E75896-002	FELT SPACER	2		
	86	E306805-174	SPACER	2		
	-	E307570-001	NUMBER LABEL	1		J
	-	E408843-001	APPROVAL LABEL	1		EN
	-	E70891-001	CLASS 1 LABEL	1		
	-	E75139-003	Z LABEL	1		U
	-	E75139-003	Z LABEL	1		UT
	-	FMND3007-003	RATING LABEL	2		UT
	-	FMND4001-003	FTZ LABEL	1		G
	-	FMND4004-001	FUSE CABEL	1		Except J,C
	-	QZL1031-101	LABEL	1		EF

⚠ : Safety Parts

**The Marks for Designated Areas**

A ..... Australia	BS ..... the U.K.	C ..... Canada	EF ..... Continental Europe
EN ..... Scandinavia	G ..... Germany	GI ..... Italy	J ..... the U.S.A.
UB ..... Hong Kong	U ..... Universal Type	US ..... Singapore	UP ..... Korea
UT ..... Taiwan	VX ..... East Eurpe	No mark indicates all area.	

# Changer Mechanism Ass'y and Parts List

■ Grease Point

Block No. 

M	2	M	M
---	---	---	---

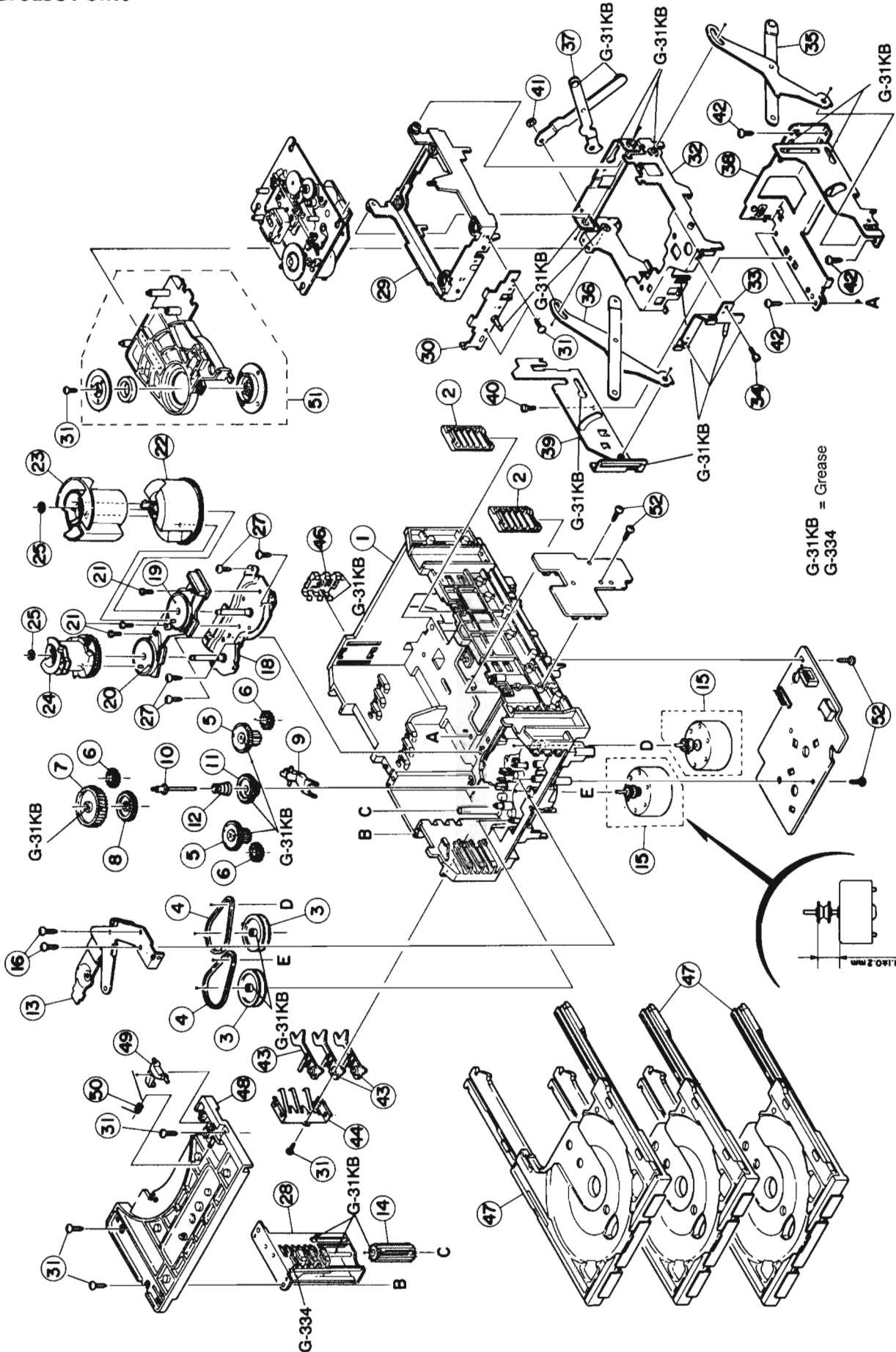



**Parts List (Changer Mechanism Ass'y)**

Block No.

M	2	M	M
---	---	---	---

△	Item	Part Number	Part Name	Q'ty	Description	Area
	1	VKS1144-003	CHASSIS BASE	1		
	2	VKS3698-002	TRAY GUIDE	2		
	3	VKS5532-002	PULLEY GEAR	2		
	4	VKB3000-164	DRIVE BELT	2		
	5	VKS5505-002	GEAR B	2		
	6	VKS5506-001	GEAR C	3		
	7	VKS5507-001	CROSS GEAR U	1		
	8	VKS5508-001	CROSS GEAR L	1		
	9	VKS5510-002	SELECT LEVER	1		
	10	VKH5769-001	GEAR STUD	1		
	11	VKS5511-001	SELECT GEAR	1		
	12	VKW5155-003	COMPRESS SPRING	1		
	13	VKM3846-002	GEAR BRACKET	1		
	14	VKS5509-001	CYLINDER GEAR	1		
	15	MSN5D257A-SA2	D.C.MOTOR	1		
	16	DPSP2616Z	SCREW	2		
	19	VKZ3172-00A	CAM SW. R ASS'Y	1		
	20	VKZ3173-00A	CAM SW. L ASS'Y	1		
	21	SPST2606Z	TAPPING SCREW	1		
	22	VKS2263-001	CAM R1	1		
	23	VKS2264-001	CAM R2	1		
	24	VKS2265-001	CAM GEAR L	1		
	25	WDL316050	SLIT WASHER	2		
	27	SBSF2608Z	TAPPING SCREW	4		
	28	VKS3702-00E	DRIVE UNIT	1		
	29	VKS2247-002	MECHA HOLDER A	1		
	30	VKL7767-00B	MECHABRACKET	1		
	31	SBSF2606Z	TAPPING SCREW	2		
	32	VKM3824-00D	M.HOLDER B AS'Y	1		
	33	VKL7802-00C	MECHA HOLDER	1		
	34	SDST2604Z	SCREW	2		
	35	VKL7810-00A	LIFTER	1		
	36	VKL7811-00A	LIFTER	1		
	37	VKL7812-00A	LIFTER	1		
	38	VKL2732-002	LIFTER BASE	1		
	39	VKM3823-001	LIFTER BRACKET	1		
	40	SDST2604Z	SCREW	1		
	41	WDL266035-2	SLIT WASHER	1		
	42	SBSF2608Z	TAPPING SCREW	8		
	43	VKS5514-001	LOCK LEVER	3		
	44	VKY3133-002	RETURN SPRING	1		
	46	VKY3134-003	CLICK SPRING	1		
	47	VKS2252-00C	TRAY ASS'Y	3		
	48	VKS2250-002	BRACKET	1		
	49	VKS5515-001	S.TRAY STOPPER	1		
	50	VKW5156-004	TORSION SPRING	1		
	51	-----	CLAMPER ASSY	1	See page 2-1	

# CD Mechanism Ass'y and Parts List

Block No. 

M	4	M	M
---	---	---	---

■ Grease Point

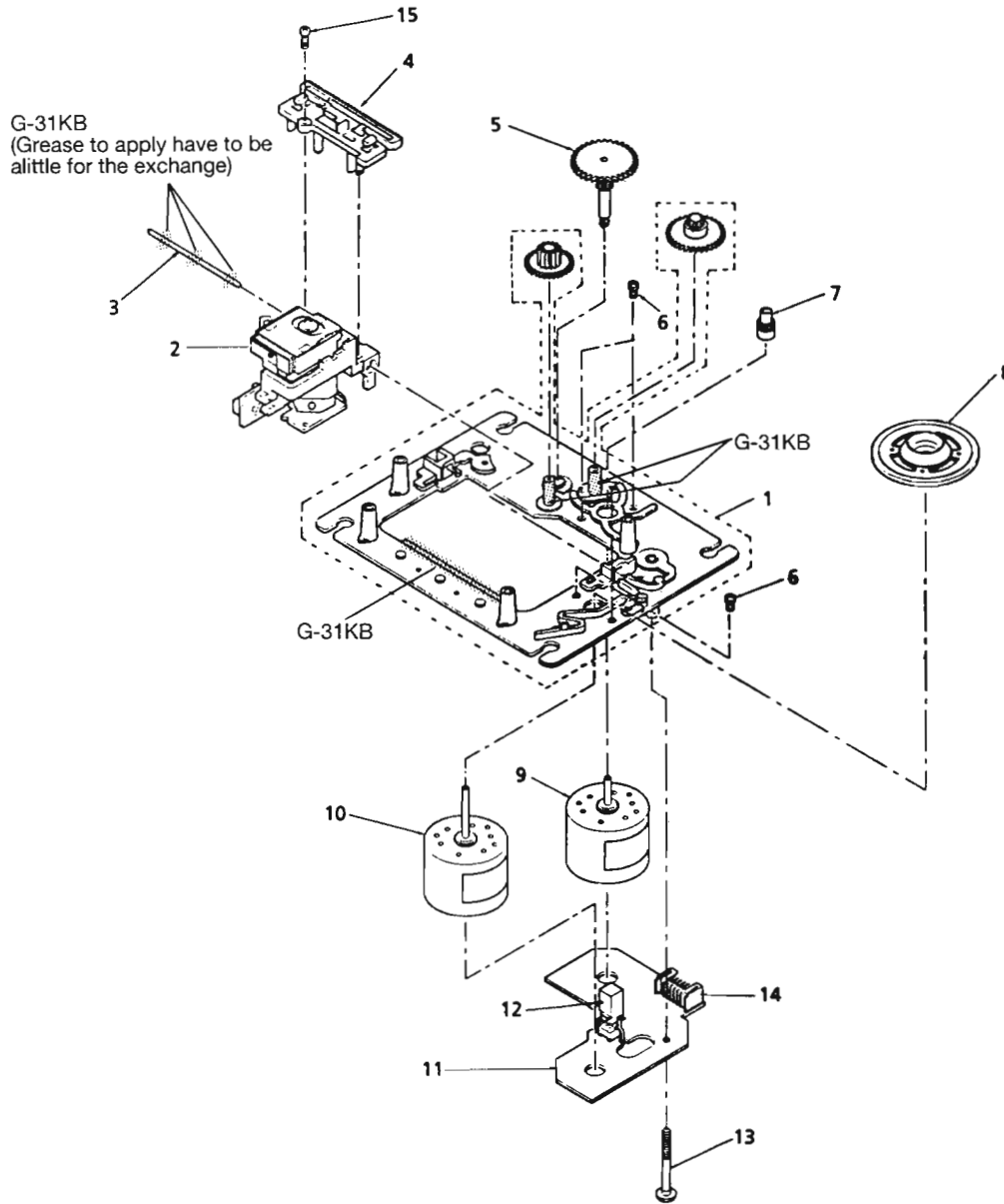

■ Parts List ( CD Mechanism Ass'y )

Item	Part Number	Part Name	Q'ty	Description	Area
1	EPB-002A	MECHANISM BASE ASSY	1		
2	OPTIMA-6S	PICK UP ASSY	1		
3	E406777-001	SHAFT	1		
4	E307746-001	CD RACK	1		
5	E307745-221SS	GEAR (3)	1		
6	SDSP2003N	SCREW	4		
7	E406750-001	PINION GEAR	1		
8	EPB309173A	TURN TABLE	1		
9	E406784-001	FEED MOTOR	1		
10	E406783-001	SPINDLE MOTOR	1		
11	EW10190-001(S)	CIRCUIT BOARD	1		
12	ESB1100-005	LEAF SWITCH	1		
13	E75832-001	SCREW	1		
14	EMV5109-006B	PLUG ASSY	1	6PIN	
15	SDSF2006Z	SCREW	1		



# Cassette Mechanism Ass'y and Parts List

■ Grease Point

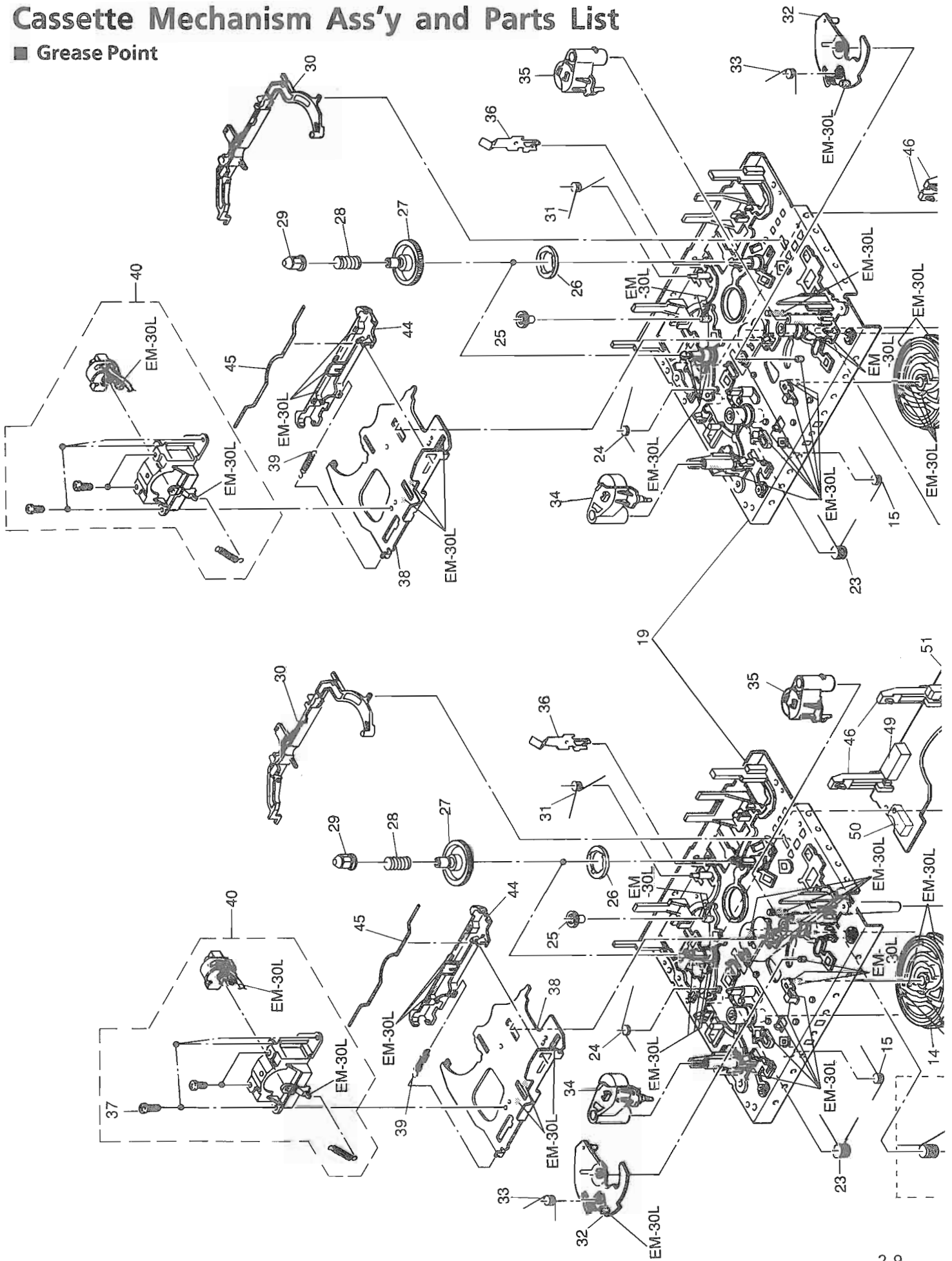

T

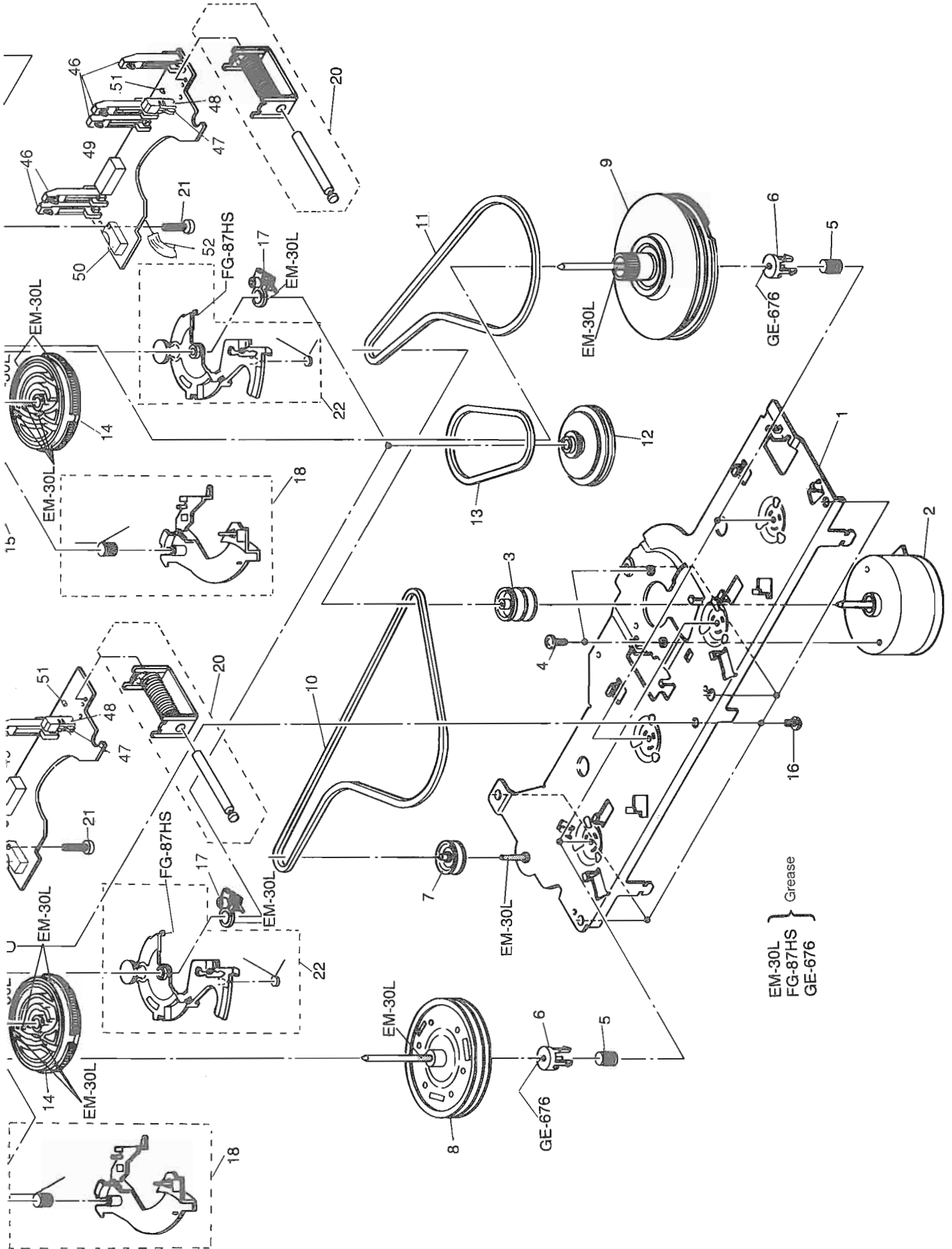

9

Block No. 

M	3	M	M
---	---	---	---

## ■ Parts List (Cassette Mechanism Ass'y)

⚠	Item	Part Number	Part Name	Q'ty	Description	Area
	1	VKM3835-00A	FLYWHEEL BRACKET	1		
	2	MMI-6H2LWK	DC MOTOR	1		
	3	VKR4746-001	MOTOR PULLEY	1		
	4	SPSP2603Z	WOOD SCREW	1		
	5	VKW5177-002	SPRING	1		
	6	VKS5524-001	THRUST GUIDE	1		
	7	VKR4747-001	IDLER PULLEY	1		
	8	VKF3202-00A	FLYWHEEL	2		
	9	VKF3200-00A	FLYWHEEL	2		
	10	VKB3000-161	CAPSTAN BELT	1		
	11	VKB3000-162	CAPSTAN BELT	1		
	12	VKS5523-00C	MAIN PULLY ASSY	2		
	13	VKB3000-167	REEL BELT	2		
	14	VKS1150-001	CONTROL CAM	2		
	15	VKW5170-002	SPRING	2		
	16	SBSF2608Z	TAPPING SCREW	6		
	17	VKS3719-002	ELEVATOR RING	2		
	18	VKS5525-00B	TRIGGER ARM	2		
	19	VKS1151-00A	CHASSIS BASE ASSY	2		
	20	VGP2401-00A	SOLENOID	2		
	21	SDST2612Z	SCREW	2		
	22	VKS3714-00B	F.F./REW.ARM	2		
	23	VKW5173-001	SPRING	2		
	24	VKW5202-002	SPRING	2		
	25	VKS5519-002	IDLER GEAR	2		
	26	VKZ4690-002	MAGNET	2		
	27	VKS3707-002	REEL GEAR	4		
	28	VKW5162-002	SPRING	4		
	29	VKS3708-002	REEL CAP	4		
	30	VKS2261-002	REEL STOPPER	2		
	31	VKW5178-001	BRAKE SPRING	2		
	32	VKS2255-001	DIRECTION LEVER	2		
	33	VKW5163-001	SPRING	2		
	34	VKP4232-00B	PINCH ROLLER	2		
	35	VKP4231-00B	PINCH ROLLER	2		
	36	VKY4670-001	SPRING	2		
	37	SDSR2004Z	SCREW	6		
	38	VKL7809-00A	BASE PLATE	2		
	39	VKW5167-002	SPRING	2		
	40	VKM3834-00F	H. MOUNT ASY	1	A MECHA	
		VKM3832-00F	H. MOUNT ASY	1	B MECHA	
	44	VKS2257-002	ACTION LEVER	2		
	45	VKW5209-003	P.R. SPRING	2		
	46	MXS00220MVL0	CASSETTE SWITCH	2		
	47	DN6851-HI	I.C.(M)	2	IC1	
	48	VKS3630-001MM	I.C.PROTECTOR	2		
	49	VMC0314-P08	CONNECT TERMINAL	1		
	49	VMC0314-P14	CONNECT TERMINAL	1		
	50	QSEC001-E03	LEVER SWITCH	2	S6	
	51	1SR139-400T-32	SI DIODE	2		
	52	VWSC04-11A13K	FLAT WIRE ASSY	1	FW1	







Capacitors

Table with columns: ITEM, PART NUMBER, DESCRIPTION, AREA. Rows include various capacitor types like QFLB1HJ-104, QXCB1CM-222Y, QETB1HM-105, etc.

SAFETY PARTS

Capacitors

Table with columns: ITEM, PART NUMBER, DESCRIPTION, AREA. Rows include various capacitor types like QFV82AJ-104, QFV81HJ-103, QFV81HJ-104, etc.

SAFETY PARTS

Resistors

Table with columns: ITEM, PART NUMBER, DESCRIPTION, AREA. Rows include various resistor types like QRC12BK-275EM, QRD161J-104, QRD161J-104, etc.

SAFETY PARTS



Others

Δ	ITEM	PART NUMBER	DESCRIPTION	AREA
Δ	CP901	ICP-N15	I.C.PROTECT	G
Δ	CP901	ICP-N15	I.C.PROTECT	GI
Δ	CP901	ICP-N15	I.C.PROTECT	U
Δ	CP901	ICP-N15	I.C.PROTECT	UB
Δ	CP901	ICP-N15	I.C.PROTECT	UP
Δ	CP901	ICP-N15	I.C.PROTECT	US
Δ	CP901	ICP-N15	I.C.PROTECT	UT
Δ	CP901	ICP-N15	I.C.PROTECT	VX
	EP501	E70225-001	EARTH PLATE	
	FT001	VMZ0087-001Z	FUSE HOLDER	A
	FT001	VMZ0087-001Z	FUSE HOLDER	BS
	FT001	VMZ0087-001Z	FUSE HOLDER	C
	FT001	VMZ0087-001Z	FUSE HOLDER	EF
	FT001	VMZ0087-001Z	FUSE HOLDER	EN
	FT001	VMZ0087-001Z	FUSE HOLDER	G
	FT001	VMZ0087-001Z	FUSE HOLDER	GI
	FT001	VMZ0087-001Z	FUSE HOLDER	J
	FT001	VMZ0087-001Z	FUSE HOLDER	V
	FT001	VMZ0087-001Z	FUSE HOLDER	VX
	FT002	VMZ0087-001Z	FUSE HOLDER	A
	FT002	VMZ0087-001Z	FUSE HOLDER	BS
	FT002	VMZ0087-001Z	FUSE HOLDER	C
	FT002	VMZ0087-001Z	FUSE HOLDER	EF
	FT002	VMZ0087-001Z	FUSE HOLDER	EN
	FT002	VMZ0087-001Z	FUSE HOLDER	G
	FT002	VMZ0087-001Z	FUSE HOLDER	GI
	FT002	VMZ0087-001Z	FUSE HOLDER	J
	FT002	VMZ0087-001Z	FUSE HOLDER	V
	FT002	VMZ0087-001Z	FUSE HOLDER	VX
	FT003	VMZ0087-001Z	FUSE HOLDER	U
	FT003	VMZ0087-001Z	FUSE HOLDER	UB
	FT003	VMZ0087-001Z	FUSE HOLDER	UC
	FT003	VMZ0087-001Z	FUSE HOLDER	UP
	FT003	VMZ0087-001Z	FUSE HOLDER	US
	FT003	VMZ0087-001Z	FUSE HOLDER	UT
	FT004	VMZ0087-001Z	FUSE HOLDER	U
	FT004	VMZ0087-001Z	FUSE HOLDER	UB
	FT004	VMZ0087-001Z	FUSE HOLDER	UC
	FT004	VMZ0087-001Z	FUSE HOLDER	UP
	FT004	VMZ0087-001Z	FUSE HOLDER	US
	FT004	VMZ0087-001Z	FUSE HOLDER	UT
	FT005	VMZ0087-001Z	FUSE HOLDER	U
	FT005	VMZ0087-001Z	FUSE HOLDER	UB
	FT005	VMZ0087-001Z	FUSE HOLDER	UC
	FT005	VMZ0087-001Z	FUSE HOLDER	US
	FT005	VMZ0087-001Z	FUSE HOLDER	UT
	FT006	VMZ0087-001Z	FUSE HOLDER	U
	FT006	VMZ0087-001Z	FUSE HOLDER	UB
	FT006	VMZ0087-001Z	FUSE HOLDER	UC
	FT006	VMZ0087-001Z	FUSE HOLDER	US
	FT006	VMZ0087-001Z	FUSE HOLDER	UT
	FT101	VMZ0087-001Z	FUSE HOLDER	
	FT102	VMZ0087-001Z	FUSE HOLDER	
	FT103	VMZ0087-001Z	FUSE HOLDER	
	FT104	VMZ0087-001Z	FUSE HOLDER	
	FW501	EWR39D-25SS	FLAT WIRE A	
	FW581	EWR33D-25SS	FLAT WIRE A	
	FW582	EWR35D-10SS	FLAT WIRE A	
	FW583	EWR36D-16SS	FLAT WIRE A	
	RY501	ESK7D24-213R	RELAY	
	SP751	VYH7653-001	SPRING	
	TB001	EMZ4001-001	TAB	
	TB002	EMZ4001-001	TAB	

Δ : SAFETY PARTS

Deck / Tuner & Source Select P. C. Board Ass'y (FMC-002)

Transistors

Δ	ITEM	PART NUMBER	DESCRIPTION	AREA
	Q103	2SC461	SI. TRANSIST	
	Q107	2SC535	SI. TRANSIST HITACHI	
	Q108	2SC461	SI. TRANSIST	
	Q111	2SD2144S(VW)	SI. TRANSIST ROHM	BS
	Q111	2SD2144S(VW)	SI. TRANSIST ROHM	EF
	Q111	2SD2144S(VW)	SI. TRANSIST ROHM	EN
	Q111	2SD2144S(VW)	SI. TRANSIST ROHM	G
	Q111	2SD2144S(VW)	SI. TRANSIST ROHM	GI
	Q111	2SD2144S(VW)	SI. TRANSIST ROHM	V
	Q111	2SD2144S(VW)	SI. TRANSIST ROHM	VX
	Q112	2SD2144S(VW)	SI. TRANSIST ROHM	BS
	Q112	2SD2144S(VW)	SI. TRANSIST ROHM	EF
	Q112	2SD2144S(VW)	SI. TRANSIST ROHM	EN
	Q112	2SD2144S(VW)	SI. TRANSIST ROHM	G
	Q112	2SD2144S(VW)	SI. TRANSIST ROHM	GI
	Q112	2SD2144S(VW)	SI. TRANSIST ROHM	V
	Q112	2SD2144S(VW)	SI. TRANSIST ROHM	VX
	Q113	2SD2144S(VW)	SI. TRANSIST ROHM	BS
	Q113	2SD2144S(VW)	SI. TRANSIST ROHM	EF
	Q113	2SD2144S(VW)	SI. TRANSIST ROHM	EN
	Q113	2SD2144S(VW)	SI. TRANSIST ROHM	G
	Q113	2SD2144S(VW)	SI. TRANSIST ROHM	GI
	Q113	2SD2144S(VW)	SI. TRANSIST ROHM	V
	Q113	2SD2144S(VW)	SI. TRANSIST ROHM	VX
	Q114	2SC1740S(R,S)	SI. TRANSIST ROHM	BS
	Q114	2SC1740S(R,S)	SI. TRANSIST ROHM	EF
	Q114	2SC1740S(R,S)	SI. TRANSIST ROHM	EN
	Q114	2SC1740S(R,S)	SI. TRANSIST ROHM	G
	Q114	2SC1740S(R,S)	SI. TRANSIST ROHM	GI
	Q114	2SC1740S(R,S)	SI. TRANSIST ROHM	V
	Q114	2SC1740S(R,S)	SI. TRANSIST ROHM	VX
	Q123	BN1A4P	DIGITAL TRA NEC	
	Q124	BN1A4P	DIGITAL TRA NEC	
	Q127	BA1L4M	DIGITAL TRA NEC	
	Q301	2SC1740S(R,S)	SI. TRANSIST ROHM	
	Q302	2SC1740S(R,S)	SI. TRANSIST ROHM	
	Q303	2SC1740S(R,S)	SI. TRANSIST ROHM	
	Q304	2SC1740S(R,S)	SI. TRANSIST ROHM	
	Q305	2SC1740S(R,S)	SI. TRANSIST ROHM	
	Q306	2SC1740S(R,S)	SI. TRANSIST ROHM	
	Q309	DTC144TS	DIGITAL TRA ROHM	
	Q310	DTC144TS	DIGITAL TRA ROHM	
	Q326	2SC1740S(R,S)	SI. TRANSIST ROHM	
	Q327	2SC1740S(R,S)	SI. TRANSIST ROHM	
	Q328	2SC1740S(R,S)	SI. TRANSIST ROHM	
	Q329	2SC1740S(R,S)	SI. TRANSIST ROHM	
	Q330	2SC945A	SI. TRANSIST NEC	BS
	Q330	2SC945A	SI. TRANSIST NEC	EF
	Q330	2SC945A	SI. TRANSIST NEC	EN
	Q330	2SC945A	SI. TRANSIST NEC	G
	Q330	2SC945A	SI. TRANSIST NEC	GI
	Q330	2SC945A	SI. TRANSIST NEC	V
	Q330	2SC945A	SI. TRANSIST NEC	VX
	Q331	DTA144ES	DIGITAL TRA ROHM	BS
	Q331	DTA144ES	DIGITAL TRA ROHM	EF
	Q331	DTA144ES	DIGITAL TRA ROHM	EN
	Q331	DTA144ES	DIGITAL TRA ROHM	G
	Q331	DTA144ES	DIGITAL TRA ROHM	GI
	Q331	DTA144ES	DIGITAL TRA ROHM	V
	Q331	DTA144ES	DIGITAL TRA ROHM	VX
	Q341	2SC1740S(R,S)	SI. TRANSIST ROHM	
	Q342	2SC1740S(R,S)	SI. TRANSIST ROHM	
	Q401	2SD2144S(VW)	SI. TRANSIST ROHM	
	Q402	2SD2144S(VW)	SI. TRANSIST ROHM	
	Q403	DTA144ES	DIGITAL TRA ROHM	
	Q421	DTC144ES	DIGITAL TRA ROHM	U
	Q421	DTC144ES	DIGITAL TRA ROHM	UB
	Q421	DTC144ES	DIGITAL TRA ROHM	UC
	Q421	DTC144ES	DIGITAL TRA ROHM	US
	Q421	DTC144ES	DIGITAL TRA ROHM	UT
	Q422	DTA144ES	DIGITAL TRA ROHM	U
	Q422	DTA144ES	DIGITAL TRA ROHM	UB
	Q422	DTA144ES	DIGITAL TRA ROHM	UC
	Q422	DTA144ES	DIGITAL TRA ROHM	US
	Q422	DTA144ES	DIGITAL TRA ROHM	UT
	Q551	2SC1740S(R,S)	SI. TRANSIST ROHM	
	Q552	2SB1187(F,G)	SI. TRANSIST ROHM	
	Q553	2SC1740S(R,S)	SI. TRANSIST ROHM	
	Q554	2SD2061(F,G)	SI. TRANSIST ROHM	
	Q557	DTC144ES	DIGITAL TRA ROHM	
	Q558	DTA144ES	DIGITAL TRA ROHM	
	Q559	DTA144ES	DIGITAL TRA ROHM	
	Q560	DTC144ES	DIGITAL TRA ROHM	
	Q563	2SB1187(F,G)	SI. TRANSIST ROHM	
	Q565	2SA933S(RS)	SI. TRANSIST	
	Q581	2SA934(Q,R)	SI. TRANSIST ROHM	

Δ : SAFETY PARTS

I.C.s

Δ	ITEM	PART NUMBER	DESCRIPTION	AREA
	IC104	LA1266A	I.C.(MONO-AN SANYO	
	IC105	LA3401	I.C.(MONO-AN SANYO	
	IC121	LC72131	I.C.(M) SANYO	
	IC301	BA15218N	I.C.(MONO-AN ROHM	
	IC302	BA15218N	I.C.(MONO-AN ROHM	
	IC303	BA15218N	I.C.(MONO-AN ROHM	
	IC304	BA3126N	I.C.(MONO-AN ROHM	
	IC401	TDA731B	I.C.(M) 0062	
	IC403	BA15218N	I.C.(MONO-AN ROHM	U
	IC403	BA15218N	I.C.(MONO-AN ROHM	UB

Δ : SAFETY PARTS

I.C.s

Δ	ITEM	PART NUMBER	DESCRIPTION	AREA
	IC403	BA15218N	I.C.(MONO-AN ROHM	UC
	IC403	BA15218N	I.C.(MONO-AN ROHM	UP
	IC403	BA15218N	I.C.(MONO-AN ROHM	US
	IC403	BA15218N	I.C.(MONO-AN ROHM	UT
	IC421	BU4066B	I.C.(DIGI-MO ROHM	U
	IC421	BU4066B	I.C.(DIGI-MO ROHM	UB
	IC421	BU4066B	I.C.(DIGI-MO ROHM	UC
	IC421	BU4066B	I.C.(DIGI-MO ROHM	UP
	IC421	BU4066B	I.C.(DIGI-MO ROHM	US
	IC421	BU4066B	I.C.(DIGI-MO ROHM	UT
	IC423	BA15218N	I.C.(MONO-AN ROHM	U
	IC423	BA15218N	I.C.(MONO-AN ROHM	UB
	IC423	BA15218N	I.C.(MONO-AN ROHM	UP
	IC423	BA15218N	I.C.(MONO-AN ROHM	US
	IC423	BA15218N	I.C.(MONO-AN ROHM	UT

Δ : SAFETY PARTS

Diodes

Δ	ITEM	PART NUMBER	DESCRIPTION	AREA
	D104	1SS133	SI. DIODE ROHM	
	D105	1SS133	SI. DIODE ROHM	
	D106	1SS133	SI. DIODE ROHM	
	D109	1SS133	SI. DIODE ROHM	
	D110	1SS133	SI. DIODE ROHM	
	D115	1SS133	SI. DIODE ROHM	
	D116	1SS133	SI. DIODE ROHM	
	D120	1SS133	SI. DIODE ROHM	
	D290	1SS133	SI. DIODE ROHM	
	D303	1SS119	SI. DIODE	BS
	D303	1SS119	SI. DIODE	EF
	D303	1SS119	SI. DIODE	EN
	D303	1SS119	SI. DIODE	G
	D303	1SS119	SI. DIODE	GI
	D303	1SS119	SI. DIODE	V
	D303	1SS119	SI. DIODE	VX
	D406	MTZ2.4JB	ZENER DIODE ROHM	U
	D406	MTZ2.4JB	ZENER DIODE ROHM	UB
	D406	MTZ2.4JB	ZENER DIODE ROHM	UP
	D406	MTZ2.4JB	ZENER DIODE ROHM	US
	D406	MTZ2.4JB	ZENER DIODE ROHM	UT
	D407	MTZ2.4JB	ZENER DIODE ROHM	U
	D407	MTZ2.4JB	ZENER DIODE ROHM	UB
	D407	MTZ2.4JB	ZENER DIODE ROHM	UP
	D407	MTZ2.4JB	ZENER DIODE ROHM	US
	D407	MTZ2.4JB	ZENER DIODE ROHM	UT
	D408	MTZ9.1JC	ZENER DIODE ROHM	
	D411	1SS133	SI. DIODE ROHM	
	D412	1SS133	SI. DIODE ROHM	
	D423	MTZ9.1JC	ZENER DIODE ROHM	U
	D423	MTZ9.1JC	ZENER DIODE ROHM	UB
	D423	MTZ9.1JC	ZENER DIODE ROHM	UC
	D423	MTZ9.1JC	ZENER DIODE ROHM	UP
	D423	MTZ9.1JC	ZENER DIODE ROHM	US
	D423	MTZ9.1JC	ZENER DIODE ROHM	UT
	D551	MTZ12JB	ZENER DIODE ROHM	
	D552	MTZ6.8JC	ZENER DIODE ROHM	
	D553	MTZ6.8JC	ZENER DIODE ROHM	
	D554	MTZ13JC	ZENER DIODE ROHM	
	D555	MTZ13JC	ZENER DIODE ROHM	
	D556	1SS133	SI. DIODE ROHM	
	D557	1SS133	SI. DIODE ROHM	
	D558	1SS133	SI. DIODE ROHM	
	D559	1SR35-200A	SI. DIODE ROHM	
	D561	1SR35-200A	SI. DIODE ROHM	
	D562	1SR35-200A	SI. DIODE ROHM	
	D563	1SR35-200A	SI. DIODE ROHM	
	D564	MTZ13JC	ZENER DIODE ROHM	
	D579	MTZ7.5JC	ZENER DIODE ROHM	
	D587	MTZ33JC	ZENER DIODE ROHM	
	D588	1SR35-100	SI. DIODE ROHM	
	D589	1SR35-100	SI. DIODE ROHM	

Δ : SAFETY PARTS

Capacitors

Δ	ITEM	PART NUMBER	DESCRIPTION	AREA
	C101	QCHB1EZ-223	0.022MF 25V CER. CAPACI	
	C103	QCHB1EZ-223	0.022MF 25V CER. CAPACI	
	C111	QCHB1EZ-223	0.022MF 25V CER. CAPACI	VX
	C113	QCC21EM-473	0.047MF 25V CER. CAPACI	
	C115	QCHB1EZ-223	0.022MF 25V CER. CAPACI	
	C116	QCSB1HJ-120Y	12PF 50V CER. CAPACI	
	C122	QCF21HP-223A	0.022MF 50V CER. CAPACI	
	C131	QCVB1CM-103Y	0.01MF 16V CER. CAPACI	
	C150	QCHB1EZ-223	0.022MF 25V CER. CAPACI	
	C151	QCF21HP-223A	0.022MF 50V CER. CAPACI	
	C152	QCF21HP-223A	0.022MF 50V CER. CAPACI	
	C153	QCC21EM-223	0.022MF 25V CER. CAPACI	
	C154	QCF21HP-223A	0.022MF 50V CER. CAPACI	
	C155	QETB1EM-226N	22MF 25V E. CAPACITO	
	C156	QCVB1CM-103Y	0.01MF 16V CER. CAPACI	
	C157	QETB1HM-474	0.47MF 50V E. CAPACITO	
	C158	QCVB1HK-101Y	100PF 50V CER. CAPACI	
	C159	QCVB1HK-101Y	100PF 50V CER. CAPACI	
	C160	QCS21HJ-101A	100PF 50V CER. CAPACI	A
	C160	QCS21HJ-101A	100PF 50V CER. CAPACI	C
	C160	QCS21HJ-101A	100PF 50V CER. CAPACI	J
	C160	QCS21HJ-101A	100PF 50V CER. CAPACI	U
	C160	QCS21HJ-101A	100PF 50V CER. CAPACI	UB
	C160	QCS21HJ-101A	100PF 50V CER. CAPACI	UC
	C160	QCS21HJ-101A	100PF 50V CER. CAPACI	UP

Δ : SAFETY PARTS





Resistors

Table with 5 columns: ITEM, PART NUMBER, DESCRIPTION, AREA. Contains resistor part numbers (e.g., QRD161J-124, QRD167J-152) and their corresponding descriptions and areas.

Δ : SAFETY PARTS

Resistors

Table with 5 columns: ITEM, PART NUMBER, DESCRIPTION, AREA. Contains resistor part numbers (e.g., QRD167J-272, QRD161J-182) and their corresponding descriptions and areas.

Δ : SAFETY PARTS





Resistors

Δ	ITEM	PART NUMBER	DESCRIPTION	AREA
Δ	R554	QRD14CJ-100SX	10 1/4W UNF. CARBON	J
Δ	R554	QRZ0077-100	10 1/4W FUSIBLE RE	A
Δ	R554	QRZ0077-100	10 1/4W FUSIBLE RE	BS
Δ	R554	QRZ0077-100	10 1/4W FUSIBLE RE	EF
Δ	R554	QRZ0077-100	10 1/4W FUSIBLE RE	EM
Δ	R554	QRZ0077-100	10 1/4W FUSIBLE RE	G
Δ	R554	QRZ0077-100	10 1/4W FUSIBLE RE	GI
Δ	R554	QRZ0077-100	10 1/4W FUSIBLE RE	U
Δ	R554	QRZ0077-100	10 1/4W FUSIBLE RE	UB
Δ	R554	QRZ0077-100	10 1/4W FUSIBLE RE	UC
Δ	R554	QRZ0077-100	10 1/4W FUSIBLE RE	UP
Δ	R554	QRZ0077-100	10 1/4W FUSIBLE RE	US
Δ	R554	QRZ0077-100	10 1/4W FUSIBLE RE	UT
Δ	R554	QRZ0077-100	10 1/4W FUSIBLE RE	V
Δ	R554	QRZ0077-100	10 1/4W FUSIBLE RE	VX
Δ	R555	QRD161J-472	4.7K 1/6W CARBON RES	
Δ	R556	QRD167J-153	15K 1/6W CARBON RES	
Δ	R558	QRD14CJ-4R7SX	4.7 1/4W UNF. CARBON	C
Δ	R558	QRD14CJ-4R7SX	4.7 1/4W UNF. CARBON	J
Δ	R559	QRD161J-242	2.4K 1/6W CARBON RES	
Δ	R563	QRD167J-152	1.5K 1/6W CARBON RES	
Δ	R564	QRX022J-2R2A	2.2 2W METAL FILM	J
Δ	R576	QRD161J-472	4.7K 1/6W CARBON RES	
Δ	R581	QRD161J-362	3.6K 1/6W CARBON RES	
Δ	R582	PTH61G25AR4R7M	POSITIVE T	A
Δ	R582	PTH61G25AR4R7M	POSITIVE T	BS
Δ	R582	PTH61G25AR4R7M	POSITIVE T	EF
Δ	R582	PTH61G25AR4R7M	POSITIVE T	EM
Δ	R582	PTH61G25AR4R7M	POSITIVE T	G
Δ	R582	PTH61G25AR4R7M	POSITIVE T	GI
Δ	R582	PTH61G25AR4R7M	POSITIVE T	U
Δ	R582	PTH61G25AR4R7M	POSITIVE T	UB
Δ	R582	PTH61G25AR4R7M	POSITIVE T	UC
Δ	R582	PTH61G25AR4R7M	POSITIVE T	UP
Δ	R582	PTH61G25AR4R7M	POSITIVE T	US
Δ	R582	PTH61G25AR4R7M	POSITIVE T	UT
Δ	R582	PTH61G25AR4R7M	POSITIVE T	V
Δ	R582	PTH61G25AR4R7M	POSITIVE T	VX
Δ	R582	QRD14CJ-4R7SX	4.7 1/4W UNF. CARBON	J
Δ	R582	QRD14CJ-4R7SX	4.7 1/4W UNF. CARBON	C
Δ	R585	QRD161J-104	100K 1/6W CARBON RES	
Δ	VR301	QVPA603-501A	500 TRIMMER RE	
Δ	VR302	QVPA603-501A	500 TRIMMER RE	
Δ	VR303	QVPA603-501A	500 TRIMMER RE	
Δ	VR304	QVPA603-501A	500 TRIMMER RE	
Δ	VR305	QVPA603-104A	100K TRIMMER RE	
Δ	VR306	QVPA603-104A	100K TRIMMER RE	
Δ	VR307	QVPA603-104A	100K TRIMMER RE	
Δ	VR308	QVPA603-104A	100K TRIMMER RE	
Δ	VR309	QVPA603-104A	100K TRIMMER RE	
Δ	VR310	QVPA603-104A	100K TRIMMER RE	
Δ	VR311	QVPA603-503A	50K VARIABLE R	
Δ	VR312	QVPA603-503A	50K VARIABLE R	

Δ : SAFETY PARTS

Others

Δ	ITEM	PART NUMBER	DESCRIPTION	AREA
Δ	AT101	EMB10YV-401K	ANTENNA TER	UC
Δ	AT101	EMB10YV-401K	ANTENNA TER	UP
Δ	AT101	EMB10YV-401K	ANTENNA TER	US
Δ	AT101	EMB10YV-401K	ANTENNA TER	UT
Δ	AT101	EMB41YV-302K	ANTENNA TER	BS
Δ	AT101	EMB41YV-302K	ANTENNA TER	EF
Δ	AT101	EMB41YV-302K	ANTENNA TER	EN
Δ	AT101	EMB41YV-302K	ANTENNA TER	G
Δ	AT101	EMB41YV-302K	ANTENNA TER	GI
Δ	AT101	EMB41YV-302K	ANTENNA TER	V
Δ	AT101	EMB41YV-302K	ANTENNA TER	VX
Δ	CF101	ECB2118-007R	CERAMIC FIL	BS
Δ	CF101	ECB2118-007R	CERAMIC FIL	EF
Δ	CF101	ECB2118-007R	CERAMIC FIL	EN
Δ	CF101	ECB2118-007R	CERAMIC FIL	G
Δ	CF101	ECB2118-007R	CERAMIC FIL	GI
Δ	CF101	ECB2118-007R	CERAMIC FIL	V
Δ	CF101	ECB2118-007R	CERAMIC FIL	VX
Δ	CF101	FMCB2123-001	CERAMIC FIL	A
Δ	CF101	FMCB2123-001	CERAMIC FIL	C
Δ	CF101	FMCB2123-001	CERAMIC FIL	J
Δ	CF101	FMCB2123-001	CERAMIC FIL	UB
Δ	CF101	FMCB2123-001	CERAMIC FIL	UC
Δ	CF101	FMCB2123-001	CERAMIC FIL	UP
Δ	CF101	FMCB2123-001	CERAMIC FIL	US
Δ	CF101	FMCB2123-001	CERAMIC FIL	UT
Δ	CF102	ECB2118-007R	CERAMIC FIL	BS
Δ	CF102	ECB2118-007R	CERAMIC FIL	EF
Δ	CF102	ECB2118-007R	CERAMIC FIL	EN
Δ	CF102	ECB2118-007R	CERAMIC FIL	G
Δ	CF102	ECB2118-007R	CERAMIC FIL	GI
Δ	CF102	ECB2118-007R	CERAMIC FIL	V
Δ	CF102	ECB2118-007R	CERAMIC FIL	VX
Δ	CF102	FMCB2123-001	CERAMIC FIL	A
Δ	CF102	FMCB2123-001	CERAMIC FIL	C
Δ	CF102	FMCB2123-001	CERAMIC FIL	J
Δ	CF102	FMCB2123-001	CERAMIC FIL	UB
Δ	CF102	FMCB2123-001	CERAMIC FIL	UC
Δ	CF102	FMCB2123-001	CERAMIC FIL	UP
Δ	CF102	FMCB2123-001	CERAMIC FIL	US
Δ	CF102	FMCB2123-001	CERAMIC FIL	UT
Δ	CN301	VMC0314-P08	CONNECT TER	
Δ	CN302	VMC0314-P08	CONNECT TER	
Δ	CN331	EMV7155-106R	CONNECT TER	
Δ	CN332	EMV7155-106R	CONNECT TER	
Δ	CN401	VMC0163-035	CONNECT TER	
Δ	CN402	VMC0075-003	CONNECTOR	
Δ	CN502	EMV7125-010R	MALE CONNEC	
Δ	CN513	EMV5167-116	CONNECT TER	
Δ	CN514	EMV5167-126	CONNECT TER	
Δ	EP102	E70225-001	EARTH PLATE	
Δ	FE101	EAF2203-004	FRONT END	A
Δ	FE101	EAF2203-004	FRONT END	C
Δ	FE101	EAF2203-004	FRONT END	J
Δ	FE101	EAF2203-004	FRONT END	U
Δ	FE101	EAF2203-004	FRONT END	UB
Δ	FE101	EAF2203-004	FRONT END	UC
Δ	FE101	EAF2203-004	FRONT END	UP
Δ	FE101	EAF2203-004	FRONT END	US
Δ	FE101	EAF2203-004	FRONT END	UT
Δ	FE101	EAF2203-005	FRONT END	BS
Δ	FE101	EAF2203-005	FRONT END	EF
Δ	FE101	EAF2203-005	FRONT END	EN
Δ	FE101	EAF2203-005	FRONT END	G
Δ	FE101	EAF2203-005	FRONT END	GI
Δ	FE101	EAF2203-005	FRONT END	V
Δ	FE101	EAF2203-005	FRONT END	VX
Δ	LP102	EQF0102-001	LOWPASS FIL	BS
Δ	LP102	EQF0102-001	LOWPASS FIL	EF
Δ	LP102	EQF0102-001	LOWPASS FIL	EN
Δ	LP102	EQF0102-001	LOWPASS FIL	G
Δ	LP102	EQF0102-001	LOWPASS FIL	GI
Δ	LP102	EQF0102-001	LOWPASS FIL	V
Δ	LP102	EQF0102-001	LOWPASS FIL	VX
Δ	LP141	EQF0101-013	LOWPASS FIL	
Δ	LP142	EQF0101-013	LOWPASS FIL	
Δ	XT102	ECX0007-200KWJ	CRYSTAL	
Δ	XT103	ECX0000-456KR	CERAMIC RES	

Δ : SAFETY PARTS

Others

Δ	ITEM	PART NUMBER	DESCRIPTION	AREA
Δ	J401	FMMW1016-002	PRINTED BOA	
Δ	L101	EMN00TV-222AJ2	PIN JACK	
Δ	L102	EQL4007-150T	INDUCTOR	BS
Δ	L102	EQL4007-150T	INDUCTOR	EF
Δ	L102	EQL4007-150T	INDUCTOR	EN
Δ	L102	EQL4007-150T	INDUCTOR	G
Δ	L102	EQL4007-150T	INDUCTOR	GI
Δ	L102	EQL4007-150T	INDUCTOR	VX
Δ	L301	ENZ6002-012	OSCILLATOR	
Δ	L303	EQL2106-562	INDUCTOR	
Δ	L304	EQL2106-562	INDUCTOR	
Δ	L305	EQL2106-223	INDUCTOR	
Δ	L306	EQL2106-223	INDUCTOR	
Δ	L401	EQL4007-2R2T	INDUCTOR	
Δ	S401	QSS7A12-E01	SLIDE SWITC	BS
Δ	S401	QSS7A12-E01	SLIDE SWITC	EF
Δ	S401	QSS7A12-E01	SLIDE SWITC	EN
Δ	S401	QSS7A12-E01	SLIDE SWITC	G
Δ	S401	QSS7A12-E01	SLIDE SWITC	GI
Δ	S401	QSS7A12-E01	SLIDE SWITC	V
Δ	S401	QSS7A12-E01	SLIDE SWITC	VX
Δ	T105	EQT2140-017	I. F. TRANSFO	
Δ	T107	ECB1560-010	CERAMIC FIL	
Δ	T111	EQR7121-004	RF COIL	A
Δ	T111	EQR7121-004	RF COIL	C
Δ	T111	EQR7121-004	RF COIL	J
Δ	T111	EQR7121-004	RF COIL	U
Δ	T111	EQR7121-004	RF COIL	UB
Δ	T111	EQR7121-004	RF COIL	UC
Δ	T111	EQR7121-004	RF COIL	UP
Δ	T111	EQR7121-004	RF COIL	US
Δ	T111	EQR7121-004	RF COIL	UT
Δ	T111	EQR7121-006	RF COIL	BS
Δ	T111	EQR7121-006	RF COIL	EF
Δ	T111	EQR7121-006	RF COIL	EN
Δ	T111	EQR7121-006	RF COIL	G
Δ	T111	EQR7121-006	RF COIL	GI
Δ	T111	EQR7121-006	RF COIL	V
Δ	T111	EQR7121-006	RF COIL	VX
Δ	AT101	EMB10YV-401K	ANTENNA TER	A
Δ	AT101	EMB10YV-401K	ANTENNA TER	C
Δ	AT101	EMB10YV-401K	ANTENNA TER	J
Δ	AT101	EMB10YV-401K	ANTENNA TER	U
Δ	AT101	EMB10YV-401K	ANTENNA TER	UB

Δ : SAFETY PARTS









# CA-D4T

## ■ Changer Control P. C. Board Ass'y

### I.C.s

Δ	ITEM	PART NUMBER	DESCRIPTION	AREA
	IC801	UPD65612GB-177	I.C.(M) NEC	
	IC802	TAB409S	I.C.(MONO-AN) TOSHIBA	
	IC803	TAB409S	I.C.(MONO-AN) TOSHIBA	

Δ : SAFETY PARTS

### Capacitors

Δ	ITEM	PART NUMBER	DESCRIPTION	AREA
	C801	QEK51AM-107	100MF 10V AL E.CAPAC	
	C802	QEK51EM-475	4.7MF 25V AL E.CAPAC	
	C803	QFLB1HJ-102	1000PF 50V MYLAR CAPA	
	C804	QCFB1HZ-104Y	0.1MF 50V CER.CAPACI	
	C805	QCVB1CM-103Y	0.01MF 16V CER.CAPACI	
	C806	QEK51CM-476	47MF 16V AL E.CAPAC	
	C807	QEK51CM-476	47MF 16V AL E.CAPAC	
	C808	QFLB1HJ-102	1000PF 50V MYLAR CAPA	
	C810	QCZ0205-155	1.5MF 25V C.CAPACITO	
	C811	QCZ0205-155	1.5MF 25V C.CAPACITO	
	C813	QCVB1CM-103Y	0.01MF 16V CER.CAPACI	
	C815	QCFB1HZ-104Y	0.1MF 50V CER.CAPACI	
	C816	QCFB1HZ-104Y	0.1MF 50V CER.CAPACI	
	C817	QCFB1HZ-104Y	0.1MF 50V CER.CAPACI	
	C818	QCFB1HZ-104Y	0.1MF 50V CER.CAPACI	
	C819	QCFB1HZ-104Y	0.1MF 50V CER.CAPACI	
	C820	QCFB1HZ-104Y	0.1MF 50V CER.CAPACI	
	C821	QCB1HK-102Y	1000PF 50V CER.CAPACI	

Δ : SAFETY PARTS

### Resistors

Δ	ITEM	PART NUMBER	DESCRIPTION	AREA
	R805	QRD161J-102	1K 1/6W CARBON RES	
	R806	QRD161J-471	470 1/6W CARBON RES	
	R807	QRD161J-471	470 1/6W CARBON RES	
	R808	QRD161J-102	1K 1/6W CARBON RES	
	R810	QRD161J-684	680K 1/6W CARBON RES	
	R811	QRD161J-105	1M 1/6W CARBON RES	
	R813	QRD161J-102	1K 1/6W CARBON RES	
	R814	QRD161J-102	1K 1/6W CARBON RES	
	R815	QRD161J-102	1K 1/6W CARBON RES	
	R816	QRD161J-102	1K 1/6W CARBON RES	

Δ : SAFETY PARTS

### Resistors

Δ	ITEM	PART NUMBER	DESCRIPTION	AREA
	R817	QRD161J-102	1K 1/6W CARBON RES	
	R818	QRD161J-102	1K 1/6W CARBON RES	
	R819	QRD161J-102	1K 1/6W CARBON RES	
	R820	QRD161J-102	1K 1/6W CARBON RES	
	R821	QRD161J-102	1K 1/6W CARBON RES	
	R822	QRD161J-102	1K 1/6W CARBON RES	
	R823	QRD161J-102	1K 1/6W CARBON RES	
	R824	QRD161J-102	1K 1/6W CARBON RES	
	R825	QRD161J-102	1K 1/6W CARBON RES	
	R826	QRD161J-102	1K 1/6W CARBON RES	
	R827	QRD161J-102	1K 1/6W CARBON RES	
	R828	QRD161J-102	1K 1/6W CARBON RES	
	R829	QRD161J-102	1K 1/6W CARBON RES	
	R830	QRD161J-102	1K 1/6W CARBON RES	
	R832	QRD161J-181	180 1/6W CARBON RES	
	R833	QRD161J-102	1K 1/6W CARBON RES	
	R834	QRD161J-102	1K 1/6W CARBON RES	
	R839	QRD167J-332	3.3K 1/6W CARBON RES	
	R840	QRD167J-562	5.6K 1/6W CARBON RES	

Δ : SAFETY PARTS

### Others

Δ	ITEM	PART NUMBER	DESCRIPTION	AREA
		QSEC001-E03	LEVER SWITC	
		SBSF260BZ	TAPPING SCR	
		VMCO289-S07K	CONNECTOR	
		VMW1377-004XMM	PW BOARD	
		VPH4116-005	CUSHION	
		VWE352-084K4K	WIRE	
		VYH7257-001MM	IC HOLDER>>	
	L801	VGP0018-100	INDUCTOR	
	L802	VGP0033-1002	INDUCTOR	
	L803	VGP0033-1002	INDUCTOR	
	L804	VGP0033-1002	INDUCTOR	
	CN801	VMCO163-R10	CONNECT TER	
	CN802	VMCO289-P07	CONNECT TER	
	CN803	VMCO324-12310	CONNECT TER	

Δ : SAFETY PARTS

# Accessories List

Block No. 

M	5	M	M
---	---	---	---

△	Item	Part Number	Part Name	Q'ty	Description	Area
	1	E30580-2375A	INSTRUCTION BOOK	1		J
		E30580-2376A	INSTRUCTION BOOK	1		EF,G,GI
		E30580-2377A	INSTRUCTION BOOK	1		U,UB,US,UT
		E30580-2378A	INSTRUCTION BOOK	1		A
		E30580-2378ABS	INSTRUCTION BOOK	1		BS
		E30580-2379A	INSTRUCTION BOOK	1		VX
		E30580-2380A	INSTRUCTION BOOK	1		C
		E30580-2381A	INSTRUCTION BOOK	1		EN
		E30580-2382A	INSTRUCTION BOOK	1		UP
	2	E309758-002	ENVELOPE	1		Except UP
		E300196-033	ENVELOPE	1		UP
	3	EQB4001-015	AM LOOP ANTENNA	1		
	4	BT-20071B	SVC CENTER LIST	1		C
	5	BT-52002-1	WARRANTY CARD	1		C
		BT-54003-1	WARRANTY CARD	1		BS
		BT-56001-1	WARRANTY CARD	1		A
		BT-20134	WARRANTY CARD	1		G
		BT-56004-3	WARRANTY CARD	1		UP
	6	BT-51006-1	REGISTER CARD	1		J
	7	BT-20066A	WARRANTY CARD	1		BS
	8	EWP201-011	BILT IN ANTENNA	1		A,C,J,U,UB,UC,UP,US,UT
	8	EWP503-001	BILT IN ANTENNA	1		BS,EF,EN,G,GI,V,VX
	9	BT-20044G	SAFETY SHEET	1		J
	10	E43486-340A	SAFETY SHEET	1		BS
	11	VMZ0139-001	CONNECT PLUG	1		U
		VMZ0139-001	CONNECT PLUG	1		UC
	11	VMZ0139-001	CONNECT PLUG	1		UT
	12	V04062-002	AC PLUG	1		US
	13	RM-SED5TU	WIRE-LESS REMOTE CONTROL	1		A,BS,C,EF,EN,G,GI,J,V,VX,
		RM-SED5TXU	WIRE-LESS REMOTE CONTROL	1		U,UB,UC,UP,US,UT
	14	UM-3(DJ)-2PSA	BATTERY	2		

△ : Safety Parts

## The Marks for Designated Areas

A .... Australia	BS .... the U.K.	C ..... Canada	EF ..... Continental Europe
EN ... Scandinavia	G ..... Germany	GI ..... Italy	J ..... the U.S.A.
UB ... Hong Kong	U ..... Universal Type	UP ..... Korea	US ..... Singapore
UT ... Taiwan	VX .... East Europe	No mark indicates all area.	

# Packing Materials and Part Numbers

Block No. 

M	6	M	M
---	---	---	---

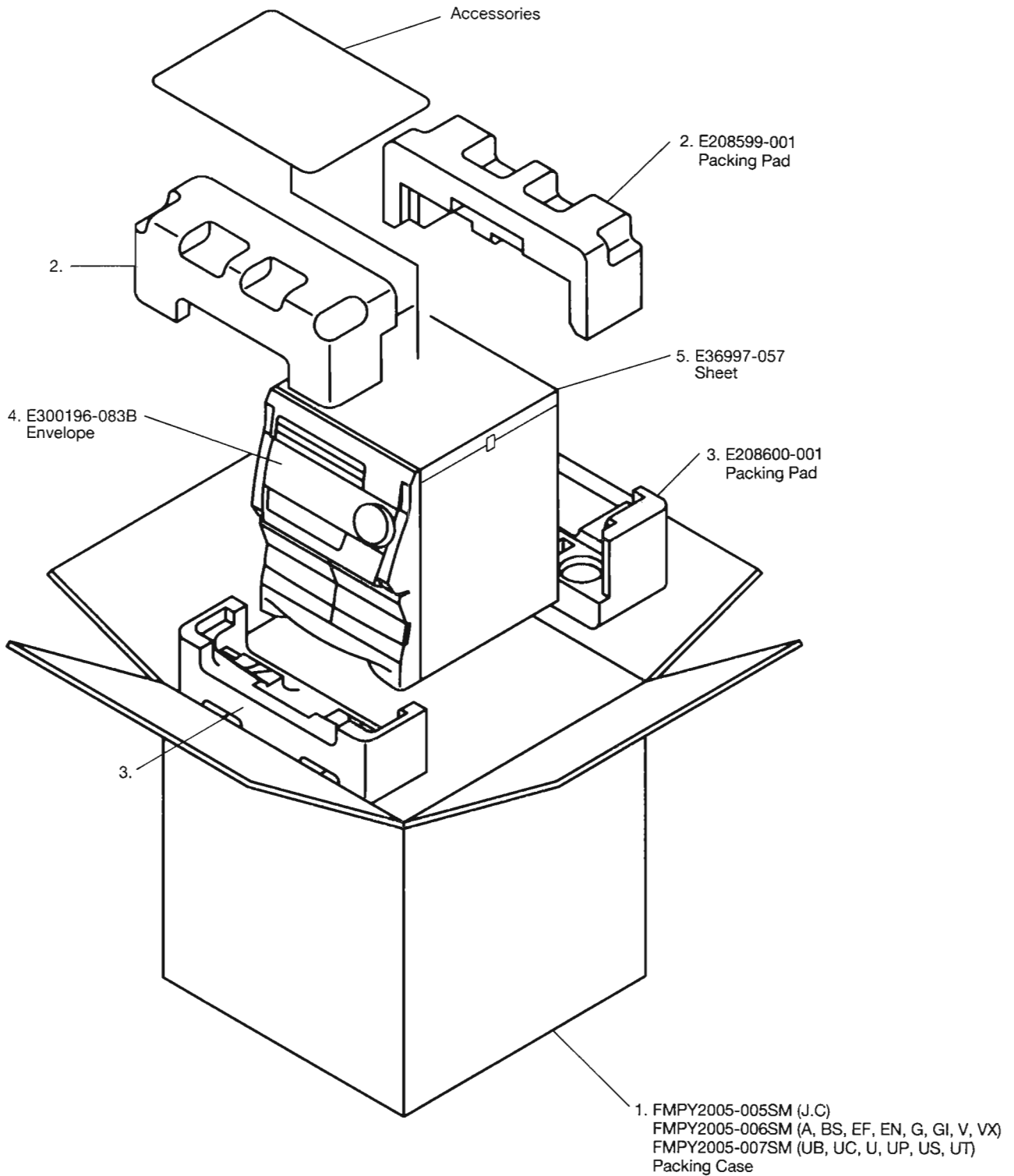

**The Mark for Designated Areas.**

A .... Australia	BS ... the U.K.	C ..... Canada	EF ... Continental Type
EN ... Scandinavia	GI ... Italy	G ..... Germany	J .... the U.S.A.
UB ... Hong Kong	U .... Universal Type	UP .... Korea	US ... Singapore
UT ... Taiwan	VX ... Ease Europe	No mark indicates all area.	





CA-D4T

**JVC**

VICTOR COMPANY OF JAPAN, LIMITED

AUDIO DIVISION, YAMATO PLANT, 1644, SHIMOTSURUMA, YAMATO-SHI, KANAGAWA-KEN, 242, JAPAN

(No. 20553U)



Printed in Japan  
9512 (S)