

# JVC

## SERVICE MANUAL

### COMPACT COMPONENT SYSTEM

# CA-D661T

Pick up	OPTIMA-150
CD signal Processor	MN35510

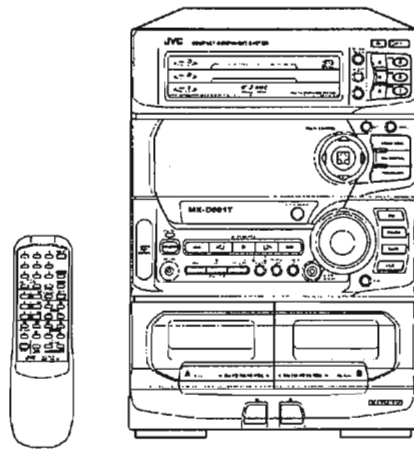

Area Suffix  
 J ... the U.S.A  
 C ... Canada

**COMPACT**  
**disc**  
**DIGITAL AUDIO**

## Contents

Safety Precautions .....	1-2	Flow of Functional Operation	
Important for Laser Products .....	1-3	Until TOC Read .....	1-59
Instruction Book .....	1-4	Maintenance of Lazer Pickup .....	1-60
Description ICs .....	1-23	Self-diagnosis for pickup .....	1-61
Internal Connection of the Display .....	1-35	Block diagram .....	1-63
Disassembly Procedures .....	1-36	Schematic Diagram .....	1-65
Connected an extension cord .....	1-54	Printed Circuit Board .....	1-72
Adjustment Procedures .....	1-55	Parts List .....	2-1

## Safety Precautions

1. The design of this product contains special hardware and many circuits and components specially for safety purposes. For continued protection, no changes should be made to the original design unless authorized in writing by the manufacturer. Replacement parts must be identical to those used in the original circuits. Services should be performed by qualified personnel only.
2. Alterations of the design or circuitry of the product should not be made. Any design alterations of the product should not be made. Any design alterations or additions will void the manufacturer's warranty and will further relieve the manufacture of responsibility for personal injury or property damage resulting therefrom.
3. Many electrical and mechanical parts in the products have special safety-related characteristics. These characteristics are often not evident from visual inspection nor can the protection afforded by them necessarily be obtained by using replacement components rated for higher voltage, wattage, etc. Replacement parts which have these special safety characteristics are identified in the Parts List of Service Manual. Electrical components having such features are identified by shading on the schematics and by ( $\Delta$ ) on the Parts List in the Service Manual. The use of a substitute replacement which does not have the same safety characteristics as the recommended replacement parts shown in the Parts List of Service Manual may create shock, fire, or other hazards.
4. The leads in the products are routed and dressed with ties, clamps, tubings, barriers and the like to be separated from live parts, high temperature parts, moving parts and/or sharp edges for the prevention of electric shock and fire hazard. When service is required, the original lead routing and dress should be observed, and it should be confirmed that they have been returned to normal, after re-assembling.
5. Leakage current check (Electrical shock hazard testing)  
After re-assembling the product, always perform an isolation check on the exposed metal parts of the product (antenna terminals, knobs, metal cabinet, screw heads, headphone jack, control shafts, etc.) to be sure the product is safe to operate without danger of electrical shock.

Do not use a line isolation transformer during this check.

- Plug the AC line cord directly into the AC outlet. Using a "Leakage Current Tester", measure the leakage current from each exposed metal parts of the cabinet, particularly any exposed metal part having a return path to the chassis, to a known good earth ground. Any leakage current must not exceed 0.5mA AC (r.m.s.).

- Alternate check method

Plug the AC line cord directly into the AC outlet. Use an AC voltmeter having, 1,000 ohms per volt or more sensitivity in the following manner. Connect a 1,500 $\Omega$  10 W resistor paralleled by a 0.15  $\mu$ F AC-type capacitor between an exposed metal part and a known good earth ground.

Measure the AC voltage across the resistor with the AC voltmeter.

Move the resistor connection to each exposed metal part, particularly any exposed metal part having a return path to the chassis, and measure the AC voltage across the resistor.

Now, reverse the plug in the AC outlet and repeat each measurement. Any voltage measured must not exceed 0.75 V AC (r.m.s.). This corresponds to 0.5 mA AC (r.m.s.).

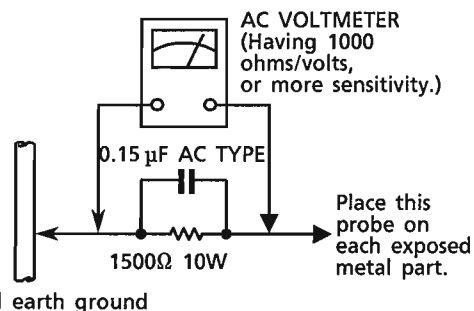

## Warning

1. This equipment has been designed and manufactured to meet international safety standards.
2. It is the legal responsibility of the repairer to ensure that these safety standards are maintained.
3. Repairs must be made in accordance with the relevant safety standards.
4. It is essential that safety critical components are replaced by approved parts.
5. If mains voltage selector is provided, check setting for local voltage.

## Important for Laser Products

1. **CLASS 1 LASER PRODUCT**
2. **DANGER** : Invisible laser radiation when open and interlock failed or defeated. Avoid direct exposure to beam.
3. **CAUTION** : There are no serviceable parts inside the Laser Unit. Do not disassemble the Laser Unit. Replace the complete Laser Unit if it malfunctions.
4. **CAUTION** : The compact disc player uses invisible laser radiation and is equipped with safety switches which prevent emission of radiation when the drawer is open and the safety interlocks have failed or are defeated. It is dangerous to defeat the safety switches.
5. **CAUTION** : If safety switches malfunction, the laser is able to function.
6. **CAUTION** : Use of controls, adjustments or performance of procedures other than those specified herein may result in hazardous radiation exposure.

**VARNING** : Osynlig laserstrålning när denna del är öppnad och spärren är urkopplad. Betrakta ej strålen.

**VARO** : Avattaessa ja suojalukitus ohitettaessa olet alttiina näkymättömälle lasersäteilylle. Älä katso säteeseen.

**ADVARSEL** : Usynlig laserstrålning ved åbning, når sikkerhedsafbrydere er ude af funktion. Undgå udsættelse for stråling.

**ADVARSEL** : Usynlig laserstrålning ved åpning, når sikkerhetsbryteren er avslott. unngå utsettelse for stråling.

### REPRODUCTION AND POSITION OF LABELS

#### WARNING LABEL

(Except for the U. S. A.)

<p><b>DANGER</b>: invisible laser radiation when open and interlock failed or defeated. AVOID DIRECT EXPOSURE TO BEAM. (e)</p>	<p><b>VARNING</b>: Osynlig laserstrålning när denna del är öppnad och spärren är urkopplad. Betrakta ej strålen. (s)</p>	<p><b>ADVARSEL</b>: Usynlig laserstrålning ved åbning, når sikkerhedsafbrydere er ude af funktion. Undgå udsættelse for stråling. (d)</p>	<p><b>VARO</b>: Avattaessa ja suojalukitus ohitettaessa olet alttiina näkymättömälle lasersäteilylle. Älä katso säteeseen. (f)</p>
--	--	---	--

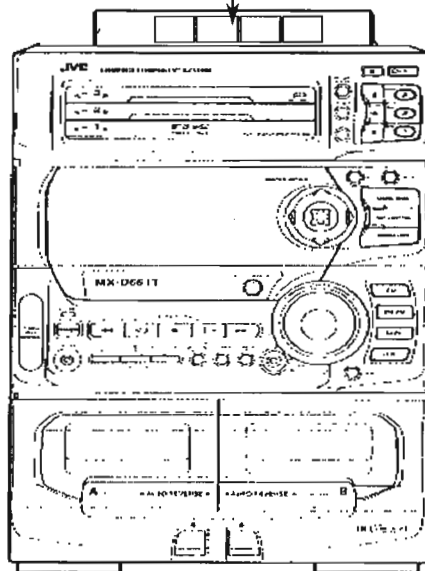

# Specifications

## Amplifier Section

Output Power	80 watts per channel, Min. RMS into 6 ohms at 1 kHz, with no more than 3% Total Harmonic Distortion.
Input Sensitivity/Impedance (1 kHz)	
VCR	300 mV/45 kohms
Speaker terminals	
Main speakers	6 - 16 ohms

## Cassette Deck Section

Frequency Response	
Type II (CrO <sub>2</sub> ) :	30 - 16,000 Hz
Type I (NORMAL) :	30 - 15,000 Hz
Wow And Flutter	0.15% (WRMS)

## CD Automatic Changer Section

CD Capacity	3 discs
Dynamic Range	93 dB
Signal-To-Noise Ratio	98 dB
Wow And Flutter	Unmeasurable

## Tuner Section

FM Tuner	
Tuning Range	87.5 - 108.0 MHz
AM Tuner	
Tuning Range	530 - 1,710 kHz

Dimensions	245 x 345 x 350.2 mm (W/H/D) (9-11/16 x 13-5/8 x 13-13/16 inches)
Mass	8.5 kg (18.8 lbs)

## Accessories

AM Loop Antenna	(1)
Remote Control	(1)
Batteries R6P (SUM-3)/AA (15F)	(2)
FM Wire Antenna	(1)

## Power Specifications

Power Requirements	AC 120 V <sup>~</sup> , 60 Hz
Power Consumption	115 watts, 150 VA 16 watts (in standby mode)

*Design and specifications are subject to change without notice.*

# Getting Started

## Accessories

Check that you have all of the following items, which are supplied with the CA-D661T.

- AM Loop Antenna (1)
- Remote Control (1)
- Batteries (2)
- FM Wire Antenna (1)

If any of these items is missing, contact your dealer immediately.

## How To Put Batteries in the Remote Control

Match the polarity (+ and -) on the batteries with the + and - markings in the battery compartment.

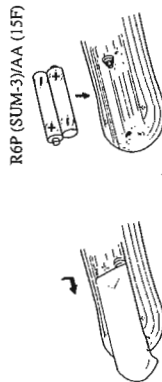

### CAUTION: Handle batteries properly.

- To avoid battery leakage or explosion:
  - Remove batteries when the Remote Control will not be used for a long time.
  - When you need to replace the batteries, replace both batteries at the same time with new ones.
  - Don't use an old battery with a new one.
  - Don't use different types of batteries together.

## Using the Remote Control

The Remote Control makes it easy to use many of the functions of the CA-D661T from a distance of up to 7m (23 feet) away.

You need to point the Remote Control at the remote sensor on the CA-D661T's front panel.

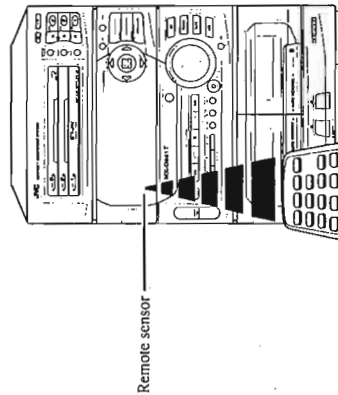

Thank you for purchasing the JVC Compact Component System. We hope it will be a valued addition to your home, giving you years of enjoyment. Be sure to read this instruction manual carefully before operating your new stereo system. Here you will find all the information you need to set up and use the system. For questions that are not answered in the manual, please contact your dealer.

## Features

- Here are some of the things that make your CA-D661T powerful and easy to use.
  - The controls and operations have been redesigned to make them very easy to use so you can spend your time listening to music.
    - With the One Touch Operation feature of JVC's **COMPU PLAY**, you can turn on the CA-D661T and start the radio, the Cassette Deck, or the CD Player with a single touch.
    - You can use the **MULTI CONTROL** stick to set the CD Player, Tuner, Timer, and Sound Mode operations.
  - To get such great sound from such a compact package the CA-D661T has:
    - Programmed sound mode includes live surround effects **D. CLUB**, **HALL**, and **STADIUM**. It also includes S.E.A. (Sound Effect Amplifier) effects **ROCK**, **POP**, and **CLASSIC**. You can also register up to three customized settings.
    - CD changer function can operate 3 discs.
      - Discs can be changed during play using the **TRIPLE TRAY**.
      - Continuous, random or program play of 3 discs.
    - The three timers, **DAILY Timer**, **REC (Recording) Timer**, and **SLEEP Timer** are extremely easy to set.
    - The Displays are large and clear. They are organized so you can tell at a glance what's happening because functions light up as you use them, and blink to tell you they are ready. They provide some important messages like "NO DISC", and other informations.

## How This Manual Is Organized

- In this manual we have incorporated some special features:
- Basic information that is the same for many different functions is grouped in one place, and not repeated in each procedure. For instance, in the section on playing a CD, we do not repeat the information about setting the volume and the sound conditions, which are discussed in the Using the Amplifier section.
  - Name of buttons and controls are written in all capital letters like this: **POWER**.
  - When we are talking about the Function, rather than the **BUTTON** or **DISPLAY**, only the first letter is capitalized.
- The manual has a table of contents to help you quickly look up what you want to know. We've enjoyed making this manual for you, and hope you will use it to enjoy the sound and many features built into your CA-D661T.

## IMPORTANT CAUTIONS

1. **Installation of the Unit**
  - Select a place which is level, dry and neither too hot nor too cold. (Between 5°C and 35°C or 41°F and 95°F).
  - Leave sufficient distance between the Unit and a TV.
  - Do not use the Unit in a place subject to vibrations.
2. **Power cord**
  - Do not handle the power cord with wet hands!
  - Some power (16 watts) is always consumed as long as the power cord is connected to the wall outlet.
  - When unplugging the Unit from the wall outlet, always pull the plug, not the power cord.
3. **Malfunctions, etc.**
  - There are no user serviceable parts inside. If anything goes wrong, unplug the power cord and consult your dealer.
  - Do not insert any metallic object into the Unit.

**CAUTION:** Make all connections before plugging the Unit into an AC power outlet.

**Connecting the FM Antenna**

**Using the Supplied Feeder Antenna**

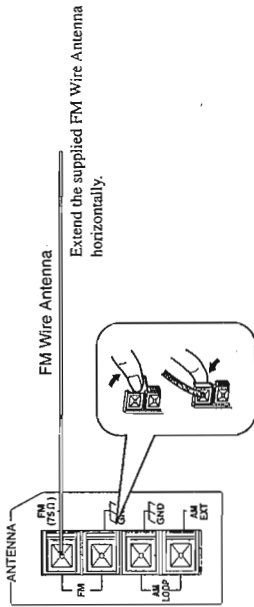

**Using an FM 75-Ohm Antenna Cable (Not Supplied)**

If reception is poor, connect the outside antenna.

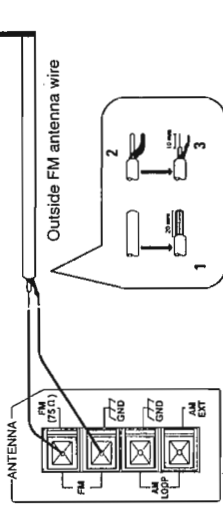

Before attaching a 75 ohm coaxial lead (the kind with a round wire going to an outside antenna), disconnect the supplied FM Wire Antenna.

**CAUTION:** To avoid noise, keep antennas away from metallic parts of the CA-D661T, connecting cord and the AC power cord.

**Connecting the AM Antenna**

AM antenna wire

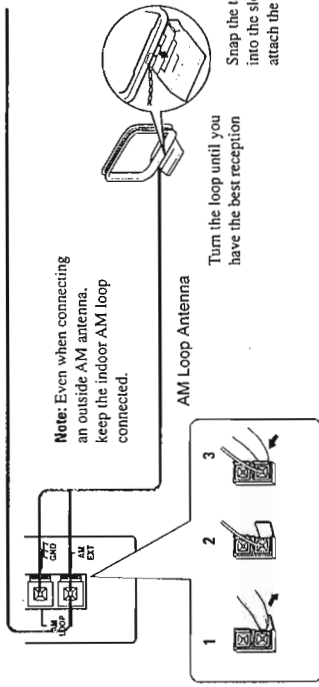

If reception is poor, connect the outside antenna.

**CAUTION:** Make all connections before plugging the Unit into an AC power outlet.

**Connecting the Speakers** (Please refer to instructions for speakers as will when you connect speakers.)

For each speaker, connect one end of the speaker wire to the speaker terminals on the back of the CA-D661T and the other end to the speaker.

1. Open each of the terminals and insert the speaker wires firmly (be sure to remove the insulation at the end of each wire first), then close the terminals.
2. Connect the red (+) and black (-) terminals of the right side speaker to the red (+) and black (-) terminals marked RIGHT on the CA-D661T.  
Connect the red (+) and black (-) terminals of the left side speaker to the red (+) and black (-) terminals marked LEFT on the CA-D661T.

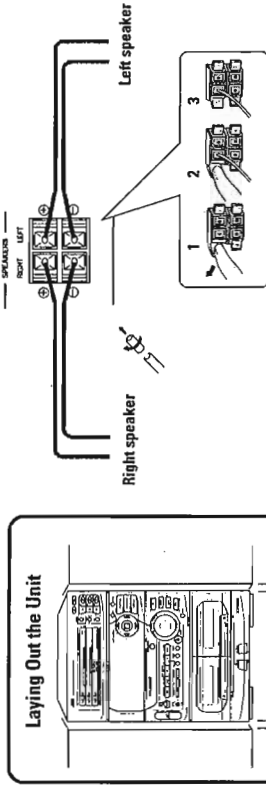

**IMPORTANT:** Use speakers with the correct impedance only. The correct impedance is indicated on the back panel.

**CAUTION:** If a TV is installed near speakers, the TV may display irregular colors. In this case, set the speakers away from the TV.

**Connecting the SUB WOOFER**

Connect the Sub-Wooferto the SUBWOOFER OUT terminal.

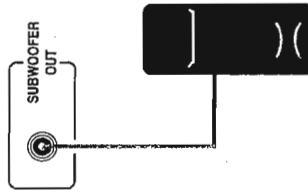

**Connecting a VCR**

Connect the VCR to the VCR terminal.

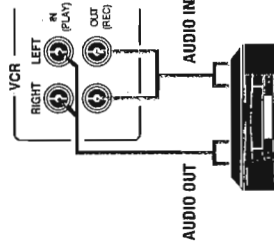

Now you can plug the AC power cord into the wall outlet, and your CA-D661T is at your command!

## Auto Power Off

When playing either a tape or a CD, Auto Power Off will shut the Unit off when the tape or CD comes to an end. Although Auto Power Off is very useful for shutting off the CA-D661T at night, you can also use it if you think you might forget to turn the Unit off when leaving the house or your room at other times of the day.

**To Use Auto Power Off**  
Press the AUTO POWER OFF button, the AUTO POWER OFF button lights up.  
**To Cancel Auto Power Off**  
Press the AUTO POWER OFF button again, the AUTO POWER OFF button goes out.



**Important Information On Using Auto Power Off**

- The end of CD playback varies depending on the play mode of the CD Player. If the play mode is Continuous or "RANDOM", when all tracks on the disc set in the CD player end, the power is automatically turned off. If the play mode is "PROGRAM", the power is automatically turned off when the last track you programmed ends.
- Auto Power Off will still work even though you press the REPEAT button.
- Repeat Mode ("REPEAT ALL" indicator lights up on the display):**  
This automatically turns off the power after all the tracks on the CDs in the CD Player have been played.
- Repeat 1 CD Mode ("REPEAT 1 CD" indicator appears on the display):**  
This automatically turns the power off after all of the tracks on the CD have been played.
- Repeat 1 Mode ("REPEAT 1" indicator lights up on the display):**  
This automatically turns the power off after the selected track has been played.
- If you press the AUTO POWER OFF button while the tape is playing:
  - If Reverse Mode is off, the Unit turns off when the current side finishes.
  - If Reverse Mode is on, the Unit will turn off when the tape finishes playing in the direction.

## Using a VCR

**Listening to a VCR**  
By playing the sound from VCR through the CA-D661T, you can gain control over how the music or program sounds. Once the connected equipment is playing through the CA-D661T, you can apply the sound effects.

- First make sure that the optional equipment is properly connected to the CA-D661T. (See page 5).

- Set the VOLUME control to 0.
- Press the VCR button.  
When CA-D661T is in Standby mode, the Unit is automatically turned on and "VCR" appears on the display.
- Start playing the equipment.
- Adjust the VOLUME control to the desired listening level.
- Select a sound effect mode, if you wish.



**To Cancel the Setting**  
Change the source by starting any one of the CA-D661T's built-in sound sources, such as the Tuner or CD Player.

### Recording to a VCR

To record to a VCR, start playback of the recording source of the CA-D661T and start recording on your VCR. (Refer to the VCR's instruction manual for details on the recording procedure for your VCR.)

- You cannot record using Sound mode effects.

## Using the Remote Control

Press the SOUND MODE button.

The display changes with each press of the button as shown below.

→D. CLUB→HALL→STADIUM→ROCK→POP→CLASSIC→MANUAL 1→MANUAL 2→MANUAL 3→OFF→

### Customizing a sound mode

You can change an existing sound mode to suit your own preferences. These changed settings can be stored in the CA-D661T's sound mode memory.

- Select the sound mode you want to change.  
If you select D. CLUB, HALL, or STADIUM, the surround effect remains unchanged, but you can adjust the S.E.A. effect.

- Press the SEA CONTROL button.

"SEA CONT" appears in the display, then the low tone section of the tone equalizer is displayed and the MULTI CONTROL indicators light up to indicate the directions in which you can use the controller.

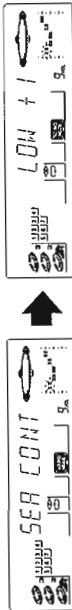
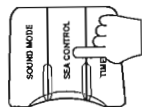

**Note:** If no adjustments are made for 5 seconds after the SEA CONTROL button is pressed, Sound mode appears on the display then reverts to the previous display.

- Adjust the settings using the MULTI CONTROL stick.

- Adjust the level by adjusting the MULTI CONTROL stick up and down.  
The level can be set between +3 and -3 in seven steps.



- Select the tone range by adjusting the MULTI CONTROL stick left and right. You can select LOW, MID, or HIGH tones.



- Press the SET button.

"MANUAL 1" appears on the display.



- Select the memory number by adjusting the MULTI CONTROL stick left and right.

You can choose from "MANUAL 1" to "MANUAL 3".

- Press the SET button again.

"MEMORY" appears on the display and the settings are stored in the memory number selected.



- The sound mode is set to the settings you have stored.

- If you store new settings to a memory number that has already been used, the new settings replace the existing setting.

# Using the Tuner

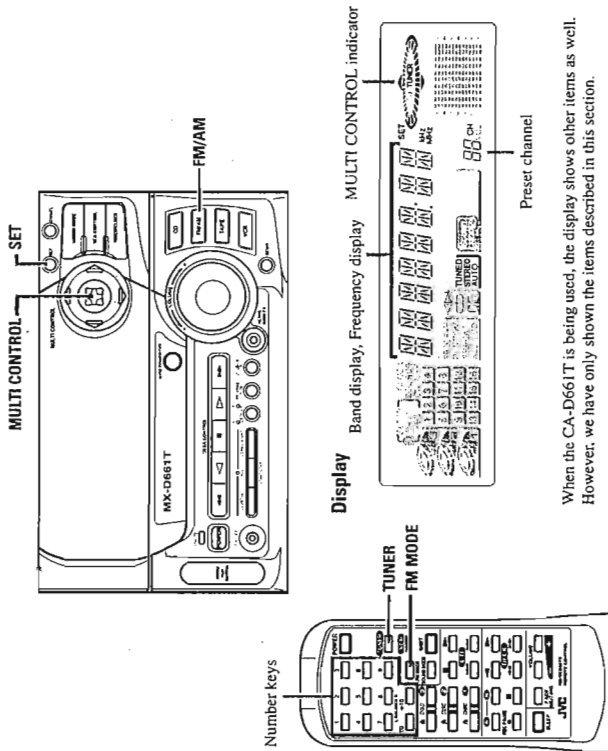

When the CA-D661T is being used, the display shows other items as well. However, we have only shown the items described in this section.

You can listen to both FM and AM stations. Stations can be tuned in manually, automatically, or from preset memory storage.

- Before listening to the radio:
  - Check that both the FM and AM antennas are firmly connected. (See page 4).

### One Touch Radio

Just press the FM/AM button (or the TUNER button on the Remote Control) to turn on the Unit and start playing the most recent station tuned in.

- You can switch from any other sound source to the radio by pressing the FM/AM button (or the TUNER button on the Remote Control).



### Tuning In a Station

Press the FM/AM button (or the TUNER button on the Remote Control) to turn on the radio. The Frequency of the previously selected channel appears on the display.



### Switching between Frequency Bands

Press the FM/AM button. Each time you press the button, the band alternates between FM and AM.

### Selecting a radio station

- Select a frequency by adjusting the MULTI CONTROL stick up or down. The frequency changes in one step increments. "TUNED" appears on the display when a signal is found. This is called Manual Tuning.
- The frequency increases when MULTI CONTROL stick is pressed upwards, and decreases when the MULTI CONTROL stick is pressed downwards.
- If the MULTI CONTROL stick is pressed up or down continuously for a few seconds, the frequency changes continuously until a signal is found, then "TUNED" appears on the display. This is called Auto Tuning.
- (Possible only after presetting stations.)



### Using the Unit

Select a preset channel by adjusting the MULTI CONTROL stick left or right.

### Using the Remote Control

- Press the TUNER button so that you can receive the most recent station tuned in.
- Select the station by entering the preset number in the number keys of the Remote Control.
  - Example: for channel 5, press 5. For channel 15, press +10 then 5. For channel 20, press +10, then 10. For channel 32, press +10 three times, then 2.

### Presetting Stations

You can store up to 40 of your favorite radio stations (FM and AM) in memory, giving you quick, easy access to the stations.

Note: In some cases, test frequencies have been already memorized for the tuner since the factory examined the tuner preset function before shipment. This is not a malfunction. You can preset the stations you want into memory by following the presetting method.

- Select a frequency band by pressing the FM/AM button.
- Tune to a station by adjusting the MULTI CONTROL stick up or down.
- Press the SET button.
  - On the display, "SET" will blink for 5 seconds.
  - During these 5 seconds while "SET" is blinking, you can assign a channel number to the station and enter it into the memory.
- Select a preset number by adjusting the MULTI CONTROL stick left or right.
- Press the SET button and the station will be assigned to the channel number showing on the display. "MEMORY" appears in the display.



MEMORY

- If a station has been previously stored using the same channel number, this will be erased and the newly selected station will be stored.
  - If "SET" in the display goes off, start again from step 3.
- Repeat steps 1 - 5 for each station you want to store in memory with a preset number.

CAUTION: If the Unit is unplugged or if a power failure occurs, the preset stations will be erased after a few days. If this happens, preset the station again.

### To Change the FM Reception Mode

When an FM stereo broadcast is hard to receive or noisy, press the FM MODE button on the Remote Control so that the "AUTO" indicator goes off in the display. Reception improves, but there are no stereo effects. In this monaural mode, noise comes out while tuning in stations (since muting is also cancelled).



To restore the stereo effect, press the FM MODE button on the Remote Control so that the "AUTO" indicator lights up. In this stereo mode, no noise comes out while tuning in stations, and you can hear stereo sounds when a program is broadcast in stereo.



## Using the Amplifier

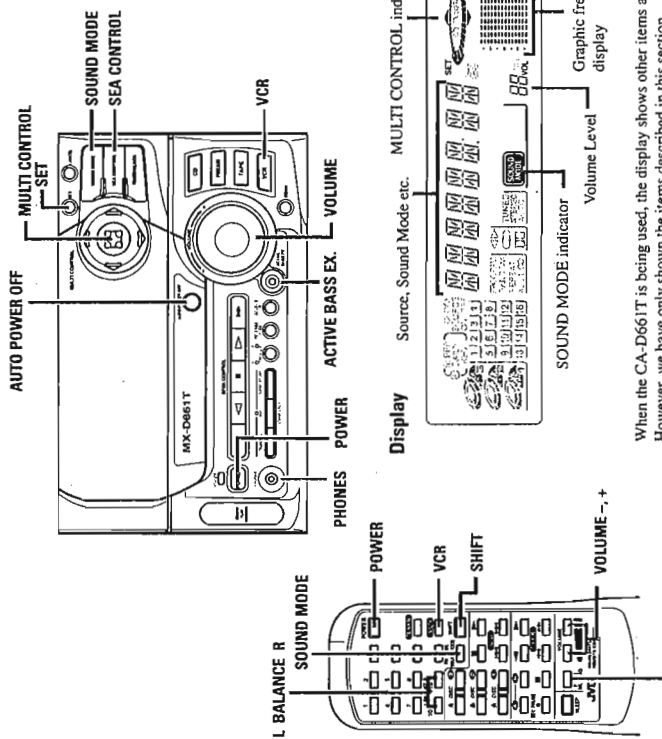

When the CA-D661T is being used, the display shows other items as well. However, we have only shown the items described in this section.

### Turning the Power On and Off

#### Turning the CA-D661T On

Press the **POWER** button.

The display comes on and the **STANDBY** indicator goes out.

The CA-D661T comes on ready to continue in the mode it was in when the power was last turned off.

- If the last thing you were doing was listening to a tape in Deck B, you are now ready to listen to a tape again in Deck B, or you can change to another source.
- If you were listening to the Tuner last, the Tuner comes on playing the station it was last set to.



#### Turning the CA-D661T Off

Press the **POWER** button again.

The **STANDBY** indicator lights up and the display is blank, except for the clock display.

- Some power (1.6 watts) is always consumed even though power is turned off (called Standby Mode).
- To switch off the Unit completely, unplug the AC power cord from the AC outlet. When you unplug the AC power cord, the clock will be reset to AM12:00 immediately, and preset Tuner stations will be erased after a few days.

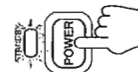

### DEMO Mode

When the CA-D661T is connected to an AC power outlet, a DEMO mode displaying some of the system's features automatically starts.

The DEMO display cycles through the following items repeatedly.

- Scrolling display of "DEMO MODE START".
- Demo of MULTI CONTROL.
- Demo of Sound Modes.
- Demo of continuous play from DISC-1 to DISC-3.
- Scrolling display of "TUNER RANDOM 40CH PRESET".

To turn the **DEMO display off**, press any of the operation buttons. "DEMO OFF" appears on the display and the DEMO display automatically stops.

DEMO OFF



To turn the **DEMO display on**, press the **DEMO** button.

**Note:** The DEMO display automatically starts when the power cord is inserted into a wall outlet.

### COMPU PLAY

**COMPU PLAY** is JVC's feature that lets you control the most frequently used functions of the CA-D661T with a single touch.

One Touch Operation starts playing a CD, turns on the radio, plays a tape, etc. with a single press of the play button for that function. What One Touch Operation does for you is to turn the power on, then start the function you have specified. If the Unit is not ready, such as no CD or tape in place, the Unit still powers on so you can insert a CD or tape.

How One Touch Operation works in each case is explained in the section dealing with that function. The **COMPU PLAY** buttons are:

#### On the Unit

- CD button
- CD Player  $\triangleright$ /II button
- CD Player DISC-1 to DISC-3 buttons
- CD Player Open/Close ( $\triangle$ ) buttons
- FM/AM button
- TAPE button
- DECK CONTROL  $\triangleleft$ ,  $\triangleright$  buttons
- VCR button

#### On the Remote Control

- TUNER button
- VCR button
- CD control  $\blacktriangleright$  button
- CD control DISC 1 to DISC 3 buttons
- CD control Open/Close ( $\blacktriangle$ ) buttons
- Deck control  $\blacktriangleleft$ ,  $\blacktriangleright$  buttons

### Adjusting the Brightness of the Display

In Standby mode, you can adjust the brightness of the clock display.

Pressing the **MULTI CONTROL** stick in the upwards direction makes the display brighter.

Pressing the **MULTI CONTROL** stick in the downwards direction makes the display darker.



**Adjusting the Volume**

Turn the VOLUME control clockwise to increase the volume or anticlockwise to decrease it. Turning the VOLUME control quickly also adjusts the volume level quickly. When using the Remote Control, press the VOLUME + button to increase the volume or press the VOLUME - button to decrease it. You can adjust the volume level between 0 and 50.

- When the CA-D661T is turned on from Standby mode, the volume is set to 0 and automatically increases to the previous volume level. To stop this automatic volume adjustment, turn the VOLUME control slightly or press the VOLUME button on the Remote Control.

**For private listening**

Connect a pair of headphones to the PHONES jack. No sound comes out of the speakers. Be sure to turn down the volume before connecting or putting on headphones.

**FADE MUTING Function**

Set the Volume Level to 0 by pressing the FADE MUTING button on the Remote Control. Press this button again to restore the Volume Level to its previous level.



**Balance adjustment**

You can use the Remote Control to adjust the left and right balance of the speakers.

1. Press the SHIFT button.
2. Press the L BALANCE R buttons (10 or +10).



The display changes to show the balance adjustment.

L - - \* - - R

Pressing the L button (10) moves the pointer to the left, pressing the R button (+10) moves the pointer to the right.

L - - \* - - R      L - - \* - - R  
 Display when set for no sound from the right speaker.      Display when set for no sound from the left speaker.

- The balance is normally set to the center position.

Note: If no adjustments are made for 5 seconds in balance adjustment mode, the display reverts to the previous display.

**Reinforcing the Bass Sound**

The richness and fullness of the bass sound is maintained regardless of how low you set the volume. You can use this effect only for playback.

To get the effect, press the ACTIVE BASS EX. (Active Bass Extension) button. "BASS ON" appears in the display and the indicator lights up.



To cancel the effect, press the button again. The message "OFF" appears in the display and the indicator goes out.

BASS ON

OFF

**Sound Modes**

The CA-D661T has some preset sound effects that give you control of the way your music sounds, so you can tailor it for your room and for the quality of the source. We can give you some idea of how each one affects the music, but the only way to really tell is to try them yourself. You can also create up to three of your own customized S.E.A. (Sound Effect Amplifier) settings and store them in the unit's memory.

- The preset sound modes include modes using surround effects and modes using S.E.A. effects.
- Sound Mode effects cannot be recorded.

**Surround effect modes**

- D. CLUB (Dance Club)**      Increases resonance and bass
- HALL**                              Adds depth and brilliance to the sound, like in a concert hall.
- STADIUM**                        Adds clarity and spreads the sound, like in an outdoor stadium.

**S.E.A. effect modes**

- ROCK**                              Boosts low and high frequencies.
- POP**                                Good for vocal music.
- CLASSIC**                        Set for wide and dynamic sound stereo systems.

**Selecting a Sound Mode**

Using the Unit

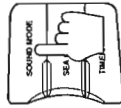

1. Press the SOUND MODE button. The currently selected Sound mode appears on the display. The MULTI CONTROL indicators light up to indicate the directions in which you can use the controller.

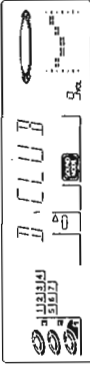

Note: If no adjustments are made for 5 seconds in Sound mode after the SOUND MODE button is pressed, the display reverts to the previous display.

2. Press the MULTI CONTROL stick to the left or right to select a Sound mode. Use the MULTI CONTROL stick to select a Sound mode while sound mode is displayed. If the display reverts to the previous display, press the SOUND MODE button again and use the MULTI CONTROL stick to select a mode.

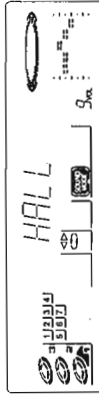

- The display also displays the frequency for the selected mode.

Moving the MULTI CONTROL stick to the right →  
 → D. CLUB → HALL → STADIUM → ROCK → POP → CLASSIC → MANUAL 1 → MANUAL 2 →  
 MANUAL 3 → OFF ←

← Moving the MULTI CONTROL stick to the left

To cancel Sound mode, select "OFF".

Unless sound mode "OFF" is selected, the red perimeter line around the SOUND MODE indicator is lit. If "OFF" is selected, the perimeter line goes out.



SOUND MODE ON

SOUND MODE OFF

# Using the CD Player

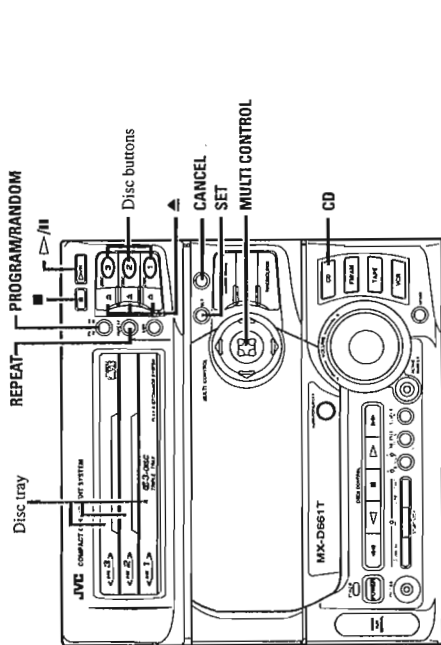

Number keys

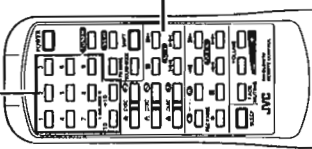

## Display

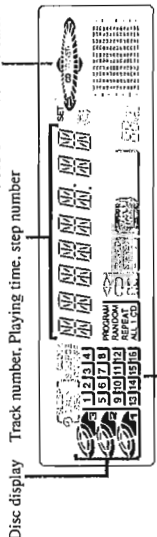

All track numbers of the loaded CD

When the CA-D661T is being used, the display shows other items as well. However, we have only shown the items described in this section.

## DISC indicator

Each of the Disc buttons acts as an indicator. This indicator is off when the CD Player is checking that there is no disc in the disc tray for the corresponding disc number. Pressing the **▲** button turns the indicator on. During playback, the disc indicator for the disc being played flashes.



Disc indicator

## Disc display

A red marker lights on the disc display for the disc number you have selected. This disc display blinks while a CD is being played. The centre of the disc display is not lit while CD Player is checking that there is no disc in the disc tray for the corresponding disc number.



Disc marker



The CA-D661T's CD Player has an Automatic Changer with 3 disc trays. You can use Continuous, Random, Program or Repeat Play for the discs in DISC-1, DISC-2 and DISC-3. Repeat Play can repeat all the tracks on all the CD's, the tracks on one of the CD's or one track on one CD. There is also the Tray Lock function, which safely keeps discs in the trays.

Here are the basic things you need to know to play a CD and locate the different selections on it. Each selection is called a track, so when we are talking about locating a track, we are also talking about how you find a certain song or performance.

### The Quickest Way To Start a CD Is With the One Touch Operation

- The power comes on, and operations are done automatically.
- Press the CD or **▶/M** button (or the **▶** button on the Remote Control).
  - If there is a CD in the disc tray of the selected (lit) disc number, playback continues from the track where it was interrupted.
  - If there is no CD in any of the disc trays, the message "OPEN" appears in the display after a few seconds and the disc tray for the marked disc opens.
- Press a DISC button (1 to 3).
- If there is a CD in the disc tray for the disc number you have selected, playback begins from the first track of that disc. If there is no CD in the disc tray, the message "OPEN" appears in the display after a few seconds and the disc tray opens.
- Press the **▲** button.
- The power turns on, and the tray opens automatically.

## Basics of Using the CD Player — Continuous Play

You can play the discs continuously in the DISC 1 to DISC 3 trays.

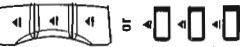

### To Insert Discs

1. Press the **▲** button on the left of the Disc button you want to insert the disc into. The disc tray slides out automatically.
2. Place a CD, with its label side up, onto the tray.

**ATTENTION:** To avoid malfunctions when you play a CD, please set the CD in the right place at the centre of the tray.

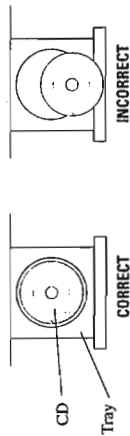

3. Press the **▲** button to close the tray.

### 4. Repeat steps 1 to 3 to insert other discs into other trays.

- To continue putting discs into other trays, even if a tray is open, by pressing the **▲** button of another disc tray, the open tray will close automatically, and the new disc tray will slide out.
- To put an 8 cm CD into a tray, insert it so that it is aligned with the groove in the tray's centre.
- "OPEN" appears in the display when a tray opens, and "CLOSE" when a tray closes.
- If a tray is open when the CA-D661T switches to Standby mode, the tray is closed automatically.

**Note:** When the CD Player is reading a disc, "..." appears in the display. While this is being displayed, the **▲** button or DISC button cannot be used. Once the display changes from "..." to another display, the **▲** button and DISC button can be used.

**To Play a Disc**

This function plays the disc in the Unit continuously.

**1. Prepare the discs.**

**2. Press the DISC button (1-3) of the disc you want to play.**

The first track of the selected disc will begin playing. When the selected disc finishes playing, the next disc will begin playing automatically. When the last disc has finished playing, the Unit will stop automatically.

- When a DISC button is pressed while a tray is open, the open tray will close automatically and Continuous Play playback begins from the first track of the disc.

To use Continuous Play from the first track of the disc selected by the disc marker, you do not need to press a DISC button (1-3), just press the  $\Delta$ /II or CD button (or  $\blacktriangleright$  button on the Remote Control).

**Playing order of discs**

- When playback starts from DISC-1, the playing order is DISC-1  $\rightarrow$  DISC-2  $\rightarrow$  DISC-3. When DISC-3 has finished, the CD Player selects DISC-1 (the disc marker is on) and stops.
- When playback starts from DISC-2, the playing order is DISC-2  $\rightarrow$  DISC-3  $\rightarrow$  DISC-1. When DISC-1 has finished, the CD Player selects DISC-2 (the disc marker is on) and stops.
- When playback starts from DISC-3, the playing order is DISC-3  $\rightarrow$  DISC-1  $\rightarrow$  DISC-2. When DISC-2 has finished, the CD Player selects DISC-3 (the disc marker is on) and stops.
  - If any of the disc trays are empty, the CD Player skips that disc tray and continues through the remaining disc trays in the order shown above.

**Note:** If there is no CD in disc tray for the DISC button you pressed, the message "OPEN" appears in the display and the disc tray automatically opens. If there is no disc in the disc tray for the selected disc number, when the  $\Delta$ /II or CD button (or the  $\blacktriangleright$  button on the Remote Control) is pressed, playback begins from the next disc.

**To stop play the disc,** press the  $\blacksquare$  button.

**To stop play and remove the disc,** press the  $\blacktriangle$  button for the disc being played.

**To pause,** press the  $\Delta$ /II button. The Disc display will blink. (The Pause function cannot be used with the  $\blacktriangleright$  button on the Remote Control.)

**To cancel pause,** press the  $\Delta$ /II button again (or press the  $\blacktriangleright$  button on the Remote Control). Play continues from the point where it was paused.

**RESUME**

When the  $\blacksquare$  button is pressed during playback, and the source is changed, the track number is memorized even when the power is turned off. The next time the  $\Delta$ /II or CD button (or the  $\blacktriangleright$  button on the Remote Control) is pressed, play resumes from the track where it was interrupted.

- To start playback from the first track, press the DISC button.

**To Change Discs While Playing**

You can replace a CD in a tray not being used, while another CD is playing.

- 1. Press the  $\blacktriangle$  button of the tray not being used.**  
The tray opens.
- 2. Replace the disc in the tray.**
- 3. Press the  $\blacktriangle$  button to close the tray.**

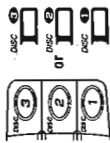

**To Select a Disc, Track Or Passage Within a Track**

Press the DISC button (1-3) for the disc tray containing the track you want to listen to.

- Playback starts from the first track of the disc you selected.
- Example: for the third disc, press 3.

**To Select a Track**

Using the Unit

Select a track by adjusting the MULTI CONTROL stick left or right.

- The MULTI CONTROL stick adjustments step through the tracks on the CD one track at a time.
  - Moving the MULTI CONTROL stick to the right selects the next track.
  - Moving the MULTI CONTROL stick to the left selects the previous track.
- If the MULTI CONTROL stick is held down continuously, the CD Player skips through the tracks on the CD continuously in the selected direction.



Using the Remote Control

Press the  $\blacktriangle$  or  $\blacktriangleright$  button to select the track.

- Each time you briefly press and release the  $\blacktriangle$  or  $\blacktriangleright$  button, the track changes by one.
  - Press and release the  $\blacktriangleright$  button to go ahead one track at a time.
  - Press and release the  $\blacktriangle$  button to go back one track at a time.
- Holding down the  $\blacktriangle$  or  $\blacktriangleright$  button allows you to change tracks continuously.



**To Select a Passage Within a Track**

While a CD is playing, press the MULTI CONTROL stick up or downwards continuously.

- If the MULTI CONTROL stick is pressed upwards the CD is played forwards quickly, if the controller is pressed downwards the CD is played backwards quickly. Release the controller when the CD reaches the passage you want to hear.

**Note:** You cannot perform these fast forwards or fast backwards operation with the remote control.



**Locating a Track With the Remote Control Directly**

Using the number keys on the Remote Control allows you to go directly to the beginning of any track.

- 1. Press the DISC button (1-3) for the disc tray containing the track you want to listen to.**
  - Example: for the third disc, press 3.
- 2. Enter the number of the track you want to listen to with the number keys.**
  - The selected track starts playing.
  - Example: for track 5, press 5. For track 15, press +10 then 5. For track 20, press +10, then 10. For track 32, press +10 three times, then 2.

**Programming the Playing Order of the Tracks**

You can change the order in which the discs and tracks play, and select only the discs and tracks you want from among those loaded in the CD Player.

- You can program up to 32 steps in any desired order from among the discs in the player.
- You can only make or change a program when the CD Player is stopped.

Using the Unit

**1. Press the PROGRAM/RANDOM button.**

The message "PROGRAM" appears on the display and the PROGRAM indicator comes on. If you have already created a program, the last step of the previous program is displayed.



- The display changes with each press of the PROGRAM/RANDOM button, as shown below.  
 $\rightarrow$  PROGRAM  $\rightarrow$  RANDOM  $\rightarrow$  Off (Continuous Play)  $\rightarrow$  (back to the beginning)

2. Select a disc with the DISC buttons (1 to 3). The display changes to the Program Entry display and the disc number and track number sections blink for a few seconds.

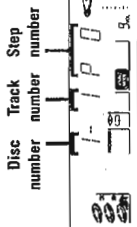
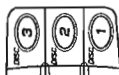

- While the display is blinking, perform the operations in steps 3 to 4. When the blinking display changes to the "PROGRAM" display, repeat the operations in steps 2 to 4.

3. Select a track for the program by adjusting the MULTI CONTROL stick left or right. The track number appears on the display.

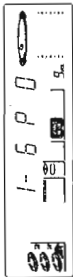

4. Press the SET button. The blinking disc number and track number changes to a steady light, and the step number is displayed.



5. Repeat steps 2 to 4 to select the other tracks for the program.

6. Press the >||/II or CD button. The Unit plays the tracks in the order you have programmed them.

**Using the Remote Control**

1. Press the PROGRAM/RANDOM button on the Unit. The message "PROGRAM" appears in the display and the PROGRAM indicator comes on. If you have already created a program, the last step of the previous program is displayed.



- The display changes with each press of the PROGRAM/RANDOM button, as shown below. → PROGRAM → RANDOM → Off (Continuous Play) → (back to the beginning)

2. Select a disc with the DISC buttons (1-3). The display changes to the Program Entry display and the disc number and track number sections blink for a few seconds.

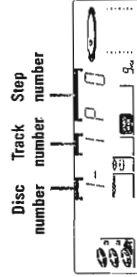

- While the display is blinking, perform the operations in step 3. When the blinking display changes to the "PROGRAM" display, repeat the operations in steps 2 to 3.



3. Press the number keys (1 to 10 and +10) to select the track to program. Example: For track 5, press 5. For track 15, press +10 then 5. For track 20, press +10 then 10. For track 32, press +10 three times, then 2. The blinking disc number and track number changes to a steady light, and the step number is displayed.

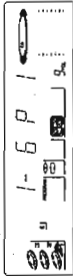

4. Repeat steps 2 to 3 to select the other tracks for the program.

5. Press the >||/II button. The Unit plays the tracks in the order you have programmed them.

- If you try to program a 33rd step, the CA-D661T lets you know that the program is full by displaying the message "FULL" on the display.
- If you try to program an disc tray that is empty, or a track number that does not exist on a disc (for example, selecting track 14 on a disc that only has 12 tracks), the selected disc or track are skipped when the program is played.
- You can skip to a particular program step during program play. To do this from the unit, move the MULTI CONTROL stick left or right, to do so from the remote control press the <||/II or >||/II buttons.
- To play the programmed tracks over and over, press the REPEAT button. The Repeat mode indicators light up in sequence with each press of the REPEAT button.

**To stop playing, press the ■ button.**

To delete all the tracks in a program, keep pressing the CANCEL button on the Unit until all the tracks in the program have been deleted, or press the >||/II button for each disc in the program. To exit Program Mode, press the PROGRAM/RANDOM button twice to change to Continuous Play mode.

**To Check the Program**

While the CD Player is stopped, use the <||/II or >||/II buttons on the remote control to check the contents of the program. Each time you press the >||/II button, the program contents are shown on the display in the programmed order. Pressing the <||/II button displays the previous step in the program.

**To Modify the Program**

Modify the contents of a program while the CD Player is stopped. Press the CANCEL button on the Unit, the last track in the program is deleted. Each time you press the button, the last track listed in the program is deleted from the program. To add a track to the program, follow the procedure above (on either the Unit or the Remote Control). The news tracks are added to the end of the program.

**Random Play**



1. Press the PROGRAM/RANDOM button while the CD Player is stopped to change to the Random Mode display.



The tracks will play in no special order when you use this mode.

- The display changes with each press of the PROGRAM/RANDOM button, as shown below. → PROGRAM → RANDOM → Off (Continuous Play) → (back to the beginning)
2. Press the >||/II or CD button (or the >||/II button on the Remote Control). The tracks are played in random order. When all of the tracks have been played, the CD Player stops.

# Using the Cassette Deck (Listening to a Tape)

**Note:** Press the DISC buttons (1-3), or the number keys, to cancel Random play and begin playback in Continuous Play mode.

- Press the REPEAT button before or during random play to instruct the CA-D661T to continue with a different random track selection after the last selection is played.

To cancel random play, press the **■** button, then press the PROGRAM/RANDOM button to select another mode.

## Repeating a Selection or the Discs

You can have all the discs, the program or the individual selection currently playing repeat as many times as you like.

Press the **REPEAT** button on the CA-D661T.

The display changes with each press of the button, as shown below.

→ **REPEAT ALL** → **REPEAT 1 CD** → **REPEAT 1** → blank display → (back to the beginning)

**REPEAT ALL:** Repeats all the tracks on the CD's in the CD Player, or all the tracks in the program.

**REPEAT 1 CD:** Repeats all the tracks on one CD.

**REPEAT 1:** Repeats one track on a CD.

- "REPEAT ALL" and "REPEAT 1" remain on the display even when you change the play mode.
- The three Repeat Modes above can be selected during Continuous Play, however, during Program Play and Random Play, you can only select REPEAT ALL or REPEAT 1.

To exit Repeat Mode, press the REPEAT button until the Repeat mode indicator on the display goes out.

## Tray Lock Function

In order to safely keep the discs in the CD Player, the three trays can be electronically locked in a single operation.

When the electronic lock is on, the trays cannot be opened even if the **▲** button is pressed.

This function can only be accessed by using the buttons on the Unit itself.

### Locking the Electronic Lock

- Put the CA-D661T's power into STANDBY mode.
- While pressing the **■** button, press the **▲** button for DISC 1's tray on the Unit.

"LOCKED" appears on the display to let you know that the trays have been locked.

LOCKED

When the CD Player trays are locked, pressing the **▲** buttons displays the message "LOCKED" on the display and the trays do not open. But, the **▲** button can be used to automatically turn on the power.

### Unlocking the Electronic Lock

- Put the CA-D661T's power into STANDBY mode.
  - While pressing the **■** button, press the **▲** button for DISC 1's tray on the Unit.
- When the unlock operation is done, "UNLOCKED" appears in the display to show that the lock has been taken off.

UNLOCKED

The trays can now be opened by pressing the **▲** buttons.  
The **▲** button can also be used to automatically turn on the power.

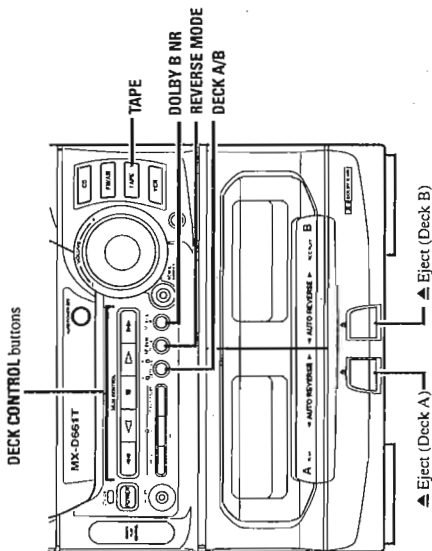

Display

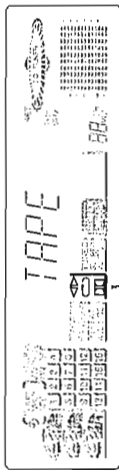

- ◀▶ : Tape Direction indicator
- ⏮⏭ : Reverse Mode indicator
- ⏪⏩ : DOLBY B NR indicator

### Tape Direction Indicator on the Display

The Tape Direction indicator tells you which direction the selected tape deck will use for playback.  
During playback, the direction indicator blinks slowly.  
During fast left or fast right, the indicator blinks quickly.  
During Music Scan mode, the direction indicator alternates between blinking slowly and quickly repeatedly.

When the CA-D661T is being used, the display shows other items as well. However, we have only shown the items described in this section.

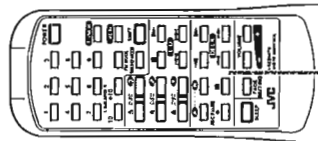

Cassette Deck control buttons

The Cassette Deck allows you to play, record and dub audio tapes.

- Most tapes are now recorded with the Dolby NR system, so first check which type of the Dolby NR system has been used on the tape. Only Dolby B NR is incorporated into the CA-D661T.
- With Automatic Tape Detection, you can listen to type I or II tapes without changing any settings.

The use of tapes longer than 120 minutes is not recommended, since characteristic deterioration may occur and these tapes easily jam in the pinch-rollers and the capstans.

## Music Scan

To find the beginning of a music track during play, use the Music Scan function. Music Scan searches for blank portions that usually separate selections, then plays the next selection.

### To Find the Beginning of the Current Selection

- Press the **REVERSE** button during play.
- Make sure that you press the **REVERSE** button in the opposite direction to that in which the tape is playing. Searching stops at the beginning of the current selection, and the current selection starts automatically.

### To Find the Beginning of the Next Selection

- Press the **REVERSE** button during play.
- Make sure that you press the **REVERSE** button in the same direction as that in which the tape is playing. Searching stops at the beginning of the next selection, and the next selection starts automatically.

### Music Scan works by detecting a 4-second long blank at the beginning of each selection, so it won't work well if your tape has:

- No blank at the beginning of a selection.
- Noise (often caused by much use or poor quality dubbing) which fills the blank with noise.
- Long, very soft passages or pauses in a selection. The scan will detect these as 4-second long blanks. If this happens, just scan again until you reach the selection you want.

## Other Useful Features of the Cassette Deck

- Use **Reverse Mode** to make the tape automatically reverse at the end of a side and start playing the other side. Press the REVERSE MODE button to change from Reverse Mode on to Reverse Mode off, or from off to on.



- **Continuous Play:** With the Reverse Mode indicator on, when tape playback in the **REVERSE** direction finishes, the Unit always checks to see if a tape is in the other deck. If there is, it automatically starts playing. This Continuous Play function works regardless of which deck starts first.
- Press the **DOLBY B NR** button to switch Dolby B Noise Reduction on (the indicator lights up) or off (the indicator goes off). If a tape is recorded with the Dolby B NR system, playing it back with the Dolby NR on will reduce tape noise and improve the clarity of the sound.

Dolby noise reduction manufactured under license from Dolby Laboratories Licensing Corporation.  
"DOLBY" and the double-D symbol are trademarks of Dolby Laboratories Licensing Corporation.



## One Touch Play

- Press the **TAPE** button.
- The power comes on and "TAPE" lights up on the display. If there is a tape in the deck corresponding to the Deck Indicator DECK A/B, that tape starts to playback. If there is no tape in the deck corresponding to the Deck Indicator, the CA-D661T automatically turns on the power and displays "TAPE" then the message "NO TAPE" and waits for you to insert a tape or select another function.
- Press the **REVERSE** button (or the **REVERSE** button on the Remote Control).
- The power comes on and "TAPE" appears in the display. When a tape is already in the tape deck, the tape is played in the direction of the button pressed. If there is no tape in the deck corresponding to the Deck Indicator, the CA-D661T automatically turns on the power and displays "TAPE" then the message "NO TAPE" and waits for you to insert a tape or select another function.

## Regular Play

If the power is already on, you can use this basic procedure:

1. Press the **TAPE** button for the deck you want to use.
2. When the cassette holder opens, put the cassette in, with the exposed part of the tape down, toward the base of the CA-D661T.
  - If the cassette carrier does not open, turn the Unit off, then back on and press the **TAPE** button again.
3. Close the holder gently.
  - When both Deck A and Deck B contain a tape, the last deck to have a tape inserted is selected. To change the selected deck, press the DECK A/B button.
  - When using the Remote Control, press the A or B button.
4. Press the **REVERSE** button (or **REVERSE** button on the Remote Control).
  - The tape is played in the direction of the button pressed for the selected deck.
  - The Cassette Deck automatically stops when one side of a tape has finished playing.

To stop playing, press the **STOP** button.

- To remove the tape, stop the tape, and press the **TAPE** button.
- To change deck while playing a tape, press the **REVERSE** button after pressing the DECK A/B button on the Unit or press the **REVERSE** button after pressing the A or B button on the Remote Control.



## Fast Left and Fast Right

- While the tape is stopped, press the **REVERSE** button and the tape will wind rapidly onto the left side of the cassette without playing.
- While the tape is stopped, press the **TAPE** button and the tape will wind rapidly onto the right side of the cassette without playing.

Note: Deck A and Deck B cannot be used for playback at the same time.

# Using the Cassette Deck (Recording)

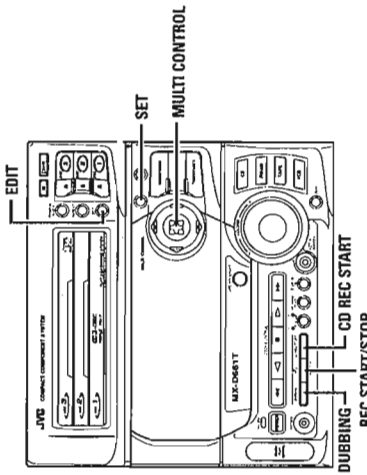

Recording onto a cassette from any of the sound sources is simple. Just place a tape in Deck B, have the source ready, make one or two settings, and you're ready to record. For each source the procedure is a little different and now we'll explain just what to do for each one. If you forget, just come back to the section which has the specific procedures you need. But first, here are a few things to make your recordings better.

## Things To Know Before You Start Recording

- ❑ It may be unlawful to record or play back copyrighted material without the consent of the copyright owner.
- ❑ Press the DOLBY B NR button — the indicator lights up — to reduce tape hiss, except when dubbing tapes, since Dolby NR is inactive in Dubbing Mode regardless of the setting of DOLBY B NR. The dubbed tape automatically contains the same processing as the source tape.
- ❑ When you want to record onto both sides of a tape, you can set Reverse mode on to do so. However, recording automatically stops after recording in the ◀ direction in Reverse mode. Therefore, make sure that the tape direction is ▶ when recording with Reverse mode on.
- ❑ The recording level, which is the volume at which the new tape is being made, is automatically set correctly, so it is not affected by the VOLUME control on the CA-D661T. Thus, during recording you can adjust the sound you are actually listening to without affecting the recording level.
- ❑ Two small tabs on the back of the cassette tape, one for side A and one for side B, can be removed to prevent accidental erasure or re-recording. To record on a cassette with the tabs removed, you must cover the holes with adhesive tape first. However, when a type II tape is used, only cover part of the hole as shown, since the other part of the hole is used to detect the tape type.
- ❑ When recording, you can hear Sound Mode effects through the speakers or headphones.
- ❑ However, the sound is recorded without Sound Mode effects.
- ❑ Type I and Type II tapes can be used for recording.



**Note:** At the start and end of cassette tapes, there is leader tape which cannot be recorded onto. Depending on the recording source, the first part of the recording may be missing because of the leader. When recording CDs or radio broadcasts, to get the beginning of the recording on the tape, first wind on the leader before beginning recording.

**CAUTION:** If recordings you have made have excessive noise or static, the Unit may be too close to a TV which was on during the recording. Either turn off the TV or increase the distance between the TV and the CA-D661T.

## Standard Recording

This is the basic method for recording any source. The CA-D661T also has special ways for recording CD to tape, and tape to tape, which save you time and effort, as well as give you some special effects. However, when you need to add a selection to a tape you have made, or are combining selections from several sources on one tape, use the method described below; just substitute the source you want into this procedure, such as a tape in Deck A, a CD, or the Tuner. You can also record from VCR with this procedure.

### To Record Any Sound Source To Tape

Follow these steps to record from any sound source onto a tape in Deck B.

#### Using the Unit

1. Insert a blank or erasable tape into Deck B.
2. Press the REVERSE MODE button if you want to record on both sides of the tape.
  - ❑ When using Reverse Mode, insert the tape so that it will be recorded in the forwards direction.
3. Check the recording direction for the tape.
 

Check that the Tape Direction indicator is the same as that for the tape in the tape deck. If the directions are different, press the ■ button after pressing the ◀ or ▶ button to set the tape direction.

  - ❑ When using Reverse Mode to record both sides of a tape, check that the Tape Direction indicator is in the forwards ▶ direction. If the direction indicator is not in the forwards direction, press the ▶ button then press the ■ button.
4. Prepare the source, by, for example, tuning in a radio station, loading CDs, or turning on connected equipment.
5. Press the REC START/STOP button.
 

The Recording indicator light comes on and the CA-D661T begins recording.

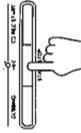

#### Using the Remote Control

1. Insert a blank or erasable tape into Deck B.
2. Press the REC PAUSE button.
 

The Recording indicator light comes on.
3. Press the REVERSE MODE button on the Unit if you want to record on both sides of the tape.
  - ❑ When using Reverse Mode, insert the tape so that it will be recorded in the forwards direction.
4. Prepare the source by, for example, tuning in a radio station, loading CDs, or turning on connected equipment.
5. Press the ◀ or ▶ button.
 

Recording starts in the direction of the button pressed.

  - ❑ When using Reverse Mode to record both sides of a tape, press the ▶ button.



**CAUTION:** Operations other than using AUTO POWER OFF, the SLEEP timer or changing the CD for the other disc trays, may cause the recording source to be changed.



### Auto Edit Recording

Using Auto Edit, you can record the CD tracks to fit the tape, so a selection isn't cut off. Auto Edit is one of the best ways to copy all of a CD onto a tape.  
Auto Edit programs the CD tracks in numerical order. To prevent the end of the last track on the front side from being cut off, the last track on the front side is selected to fit on the remaining tape length.

1. Prepare CDs. (See page 15.)
2. Press the EDIT button on the Unit.  
"DISC" appears in the display.



DISC

3. Press the DISC button for the disc you want to record.  
After "TAPE C..." appears on the display, the optimum tape length for the disc you want to record is displayed.



- You can select a different length of tape, depending on the actual size of the tape you are using, from eleven possibilities programmed into the CA-D661T: 40, 46, 50, 54, 60, 64, 70, 74, 80, 84, 90. Select the tape length that corresponds to the length of tape you are using, or the nearest length to it, by adjusting the MULTI CONTROL stick left or right.
- If you pick a tape length shorter than the total playing time of the CD, the last tracks on both sides of the tape will be faded out as the tape ends.



4. Press the SET button.  
The tracks to be recorded on side B of the tape appear on the display.

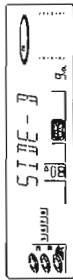

- To display the tracks that will be recorded on side A of the tape, press the SET button again. The Unit switches between side A and side B with each press of the SET button.
- To check the tracks that will be recorded, press the ◀ or ▶ buttons on the Remote Control.

5. Insert a cassette in Deck B to record on.  
When you want to record on both sides of a tape, press the REVERSE MODE button to turn Reverse mode on.

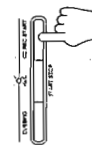

6. Press the CD REC START button.  
The Unit plays the CD and starts recording. If the tape has not been rewound, the Unit rewinds the tape before starting to record the CD.

When the tape is ready, to prevent the start of a track being cut, the CA-D661T creates a blank period of 10 seconds before it starts to record the CD. While a blank period is being created, "TAPE SIDE-A STANDBY" scrolls through the display. (The CA-D661T also creates a 10 second blank period at the start of side B of the tape. While a blank period is being created, "TAPE SIDE-B STANDBY" scrolls through the display.)

When the recording is finished, the message "CD REC FINISHED" scrolls by on the display. The CD Player and Cassette Deck stop.

**Notes for using Reverse Mode for recording**  
When recording in Reverse Mode, the CA-D661T automatically stops when it reaches the end of the reverse direction. To record on both sides of a tape, make sure that the recording direction for the tape inserted into Deck B is forwards ▶, and that the Tape Direction indicator is also forwards ▶, before you start recording.

**To Pause at Any Time During the Recording Process**  
Press the REC PAUSE button on the Remote Control. Then press either the ◀ or ▶ button on the Remote Control or REC START/STOP button on the Unit to restart recording.

**To Stop at Any Time During the Recording Process**  
Press the REC START/STOP button on the Unit again, or press the ■ button.

### CD Direct Recording

Everything on the CD goes onto the tape in the order it is on the CD, or according to the order you have set in a program.

1. Prepare CDs. (See page 15.)  
Check that the CD Player is not playing a CD.
2. Insert a cassette in Deck B to record on.  
When you want to record on both sides of a tape, press the REVERSE MODE to turn Reverse Mode on. Check that the recording direction for the tape and the Tape Direction indicator are correct. (See "Notes for using Reverse Mode for recording" earlier on this page.)

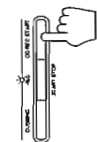

3. Press the CD REC START button.  
"CD REC" is displayed on the display then the Unit plays the CD and starts recording.  
At the end of the tape, the CA-D661T automatically goes back to the beginning of the last selection and re-records it, this time gently fading out at the end. If you selected Reverse Mode, "TAPE SIDE-B STANDBY" scrolls through the display then the reverse side starts with the last selection of the first side. The last selection of the first side will fade out at the end. (A 10 second blank is created at the beginning of the reverse side.)  
When the recording is finished, the message "CD REC FINISHED" scrolls by on the display. The CD Player and Cassette Deck stop.

**To Stop at Any Time During the Recording Process**  
Press the REC START/STOP button or the ■ button on the Cassette Deck or CD Player (or the ■ button on the Remote Control).

- Notes:**
- When the Auto Power Off function is turned on while recording a CD, the power will automatically turn off when the CD finishes. Be careful when the Auto Power Off function is turned on while recording a CD in Repeat Mode, as repeat will be cancelled and the power will automatically turn off with Repeat Mode ("REPEAT ALL", "REPEAT 1 CD", or "REPEAT 1"). (Page 11)
  - When making SLEEP timer settings while doing CD Direct recording, set the time so that there is enough leeway to finish the recording before the power goes off. If the time is set to about the length of the CD, the power may go off before recording finishes.

For CD Direct Recording using more than one disc, use a blank tape. If you use a prerecorded tape, prerecorded material may not be erased between newly-recorded tracks.

# Using the Timers

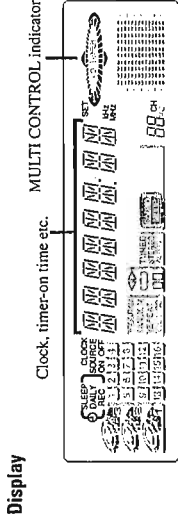
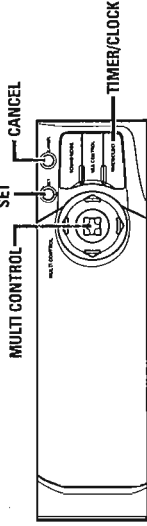

When the CA-D661T is being used, the display shows other items as well. However, we have only shown the items described in this section.

- The timers lets you control recording and listening functions automatically.
- Three types of timers are available:
- DAILY Timer** — Use this timer to set wake up everyday to music from any source, instead of an alarm clock.
  - REC (Recording) Timer** — Unattended recording of radio broadcasts. You can set the starting time and length of the recording.
  - SLEEP Timer** — Fall asleep and have your CA-D661T turn off automatically after a certain length of time.

## Setting the Clock

The timers depend on the clock: the clock must be right for the timers to work as you expect. You can set the clock whether the Unit is on or off.

**Note that the clock must be set, or the timers cannot be set.**

1. Press the **TIMER/CLOCK** button. The "CLOCK" indicator and the hour digits blink on the display.
2. Set the hour by adjusting the **MULTI CONTROL** stick left or right. Adjust the **MULTI CONTROL** stick to the right to advance the hour setting, adjust it to the left to decrease the setting. Press the **MULTI CONTROL** stick continuously to increase or decrease the hour setting rapidly.
3. Press the **SET** button. The minute digits blink on the display.
4. Set the minute by adjusting the **MULTI CONTROL** stick left or right. Adjust the **MULTI CONTROL** stick to the right to advance the minute setting, adjust it to the left to decrease the setting. Press the **MULTI CONTROL** stick continuously to increase or decrease the minute setting rapidly in 10 minute steps.
5. Press the **SET** button. "CLOCK OK" appears on the display, and the clock starts at zero seconds from the set time.

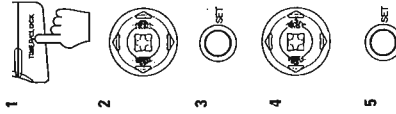

To stop at any time while recording, press the **■** button (CD control or Cassette Deck control) or the **REC START/STOP** button. If you press the CD control **■** button, the Cassette Deck creates a four second blank space after the CD Player stops. If you press any other button to stop the recording, the CD Player and Cassette Deck stop at the same time.

To cancel **Auto Edit**, press the **▲** button for disc number being recorded, or press the **PROGRAM/RANDOM** button while the CD Player is stopped.

**Note:** When making **SLEEP** timer settings while doing **Auto Edit** recording, set the time so that there is enough leeway to finish the recording before the power goes off. If the time is set to about the length of the CD, the power may go off before recording finishes.

## Tape to Tape Recording (Dubbing)

Recording from one tape to another is called dubbing.

- You can dub tapes simply, with just a single button.
- When dubbing tapes, make sure that the playback direction of Deck A and Deck B are the same.
  - When you want to record both sides of a tape, press the **REVERSE MODE** button to turn Reverse mode on.
  - It is preferable that the type of tape (Type I or Type II) you record from be the same as the type you record onto.

### How to Use the DUBBING Button

1. Insert the source cassette you want to copy from into **Deck A** for playback.
2. Insert the blank or erasable cassette you want to copy onto in to **Deck B** for recording.
3. Press the **DUBBING** button. Deck A and Deck B will start simultaneously.

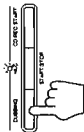

To stop dubbing, press the **■** button or **REC START/STOP** button.

- Dolby NR is inactive in dubbing mode regardless of the setting of **DOLBY B NR**. The dubbed tape automatically contains the same processing as the source tape.
- When doing dubbing with the **DUBBING** button, you can hear Sound Mode effects through the speakers or headphones. However, the sound is dubbed without Sound Mode effects.

**CAUTION:** If there is a power failure, the clock loses its setting. The display shows "AM 12:00", and the clock must be reset.

### Setting the DAILY Timer

With this timer you can wake up to music from a CD, tape, your favorite radio program, or other source.

- You can set the DAILY Timer whether the Unit is on or off.

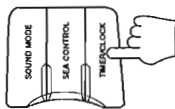

#### Procedure For Setting the DAILY Timer

1. Press the **TIMER/CLOCK** button so that "DAILY Timer" appears in the display.

The message "DAILY" blinks and the DAILY indicator light blinks on the display.

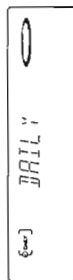

- The display changes with each press of the button, as shown below.  
**DAILY** (blinks) → **ON TIME** (blinks) → **REC** (blinks) → **ON TIME** (blinks) → **CLOCK** (blinks) (Clock setting mode) → original display before the **TIMER/CLOCK** button was pressed → (back to the beginning)

**Note:** If the clock has not been set, even if the **TIMER/CLOCK** button is pressed you cannot select the DAILY Timer.

2. Press the **TIMER/CLOCK** button again.

The display changes to the On Time display.

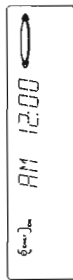

3. Set the time you want the Unit to turn on.

Set the time by adjusting the **MULTI CONTROL** stick left or right in the same way you set the time for the clock. Press the **SET** button to set the on time.



The "OFF time" hour setting starts to blink after the "ON time" minute setting is set.

4. Set the time you want the Unit to turn off.

Set the time by adjusting the **MULTI CONTROL** stick left or right in the same way you set the time for the clock. Press the **SET** button to set the off time.

- When the off time has been set, the display changes to the source selection display.

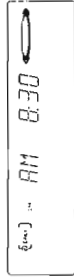

5. Select the source you want to listen to. To use the Tuner as the source:

1. Adjust the **MULTI CONTROL** stick left or right until "TUNER" blinks in the display.



2. Adjust the **MULTI CONTROL** stick up or down to select the preset channel you want to listen to.

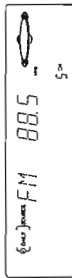

3. Press the **SET** button.

To use a CD as the source:

1. Adjust the **MULTI CONTROL** stick left or right until "CD ---" blinks in the display.

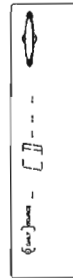

2. Adjust the **MULTI CONTROL** stick up or down to select the disc tray containing the CD you want to play.

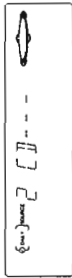

3. Press the **SET** button.

If you press the **SET** button without selecting a disc, the last disc played by the CA-D661T will be used.

4. Adjust the **MULTI CONTROL** stick up or down to select the starting track of the CD. You can only select up to 20 tracks.



5. Press the **SET** button.

If you press the **SET** button without selecting a track, playback will start from the first track on the CD.



To use a Cassette Deck as the source:

1. Adjust the **MULTI CONTROL** stick left or right until "TAPE" blinks in the display.



2. Press the **SET** button.

To use another source:

Use this to select a radio station that has not been preset.

1. Adjust the **MULTI CONTROL** stick left or right until "..." blinks in the display.



2. Press the **SET** button.

The last source used is selected.

**6. Setting the Volume Level.**

Adjust the MULTI CONTROL stick left or right to set the volume level.



- VOLUME - A:** Sets the volume level to 10.
- VOLUME - B:** Sets the volume level to 15.
- VOLUME - C:** Sets the volume level to 20.
- VOLUME - :** Sets the volume to the last volume setting used.

**7. Press the SET button.**

The "DAILY" indicator changes from a blinking display to a steady display. The ON TIME, OFF TIME, PLAYBACK SOURCE (including the disc number and track number if a CD source is selected) are displayed then the display reverts to the previous display, before the Timer was set.

Turn the power off if you made the timer settings with the power turned on.

- A few seconds before the start for the timer, the CA-D661T automatically turns on the power, and the "DAILY TIMER" blinks on the display. When the set time is reached, playback starts using the selected source. After the finish time for the timer is reached, the power is automatically turned off again.
  - If a button is pressed when the DAILY Timer is operating, recording continues but the timer is cancelled.
- Before Turning Off the Unit**
- If the source is a CD, make sure that there is a CD in the selected disc number.
  - If the source is a tape:
    - The tape in the deck corresponding to the Deck Indicator mark is played. Make sure that there is a tape in the selected Cassette Deck.
    - Check that the tape direction is correct. This is important especially when Reverse Mode is off.
  - Set Reverse Mode on if you want to play both sides of the tape.
  - Select the Sound Mode if you want to listen using a Sound Mode effect.

**To change the DAILY Timer setting**

To change the settings for the DAILY Timer, repeat the setting procedure from the beginning.

**Turning the DAILY Timer On and Off**

Once the DAILY Timer has been set, it will be activated at the same time every day until the setting is turned off.

To turn the DAILY Timer off, press the TIMER/CLOCK button until "DAILY" appears in the display. Press the CANCEL button. "OFF" appears in the display and the DAILY indicator goes out. To turn the DAILY TIMER on again, press the TIMER/CLOCK button until "DAILY" appears in the display, then press the SET button. The Timer ON TIME, OFF TIME, PLAYBACK SOURCE (including the disc number and track number if a CD source is selected) are displayed on the display.

**CAUTION: If the CA-D661T is unplugged, or a power failure occurs, the timer setting will be erased in a few days. If the settings are erased in this way, reset the timer settings.**

**Setting the REC (Recording) Timer**

With the Recording Timer you can make a tape of a radio broadcast automatically whether or not you are home. For the timer to work correctly, you need to make sure of the following in addition to setting the time for the Tuner and Cassette Deck to come on:

- You can set the REC Timer whether the Unit is on or off.
- The tape you want to record onto must be in Deck B.

**Procedure for Setting the REC Timer**

- 1. Press the TIMER/CLOCK button so that "REC Timer" appears in the display.**  
The message "REC" blinks and the REC indicator light blinks on the display.



- The display changes with each press of the button, as shown below.  
DAILY (blinks) → ON TIME (blinks) → REC (blinks) → ON TIME (blinks) → CLOCK (blinks) (Clock setting mode) → original display before the TIMER/CLOCK button was pressed → (back to the beginning)

**Note:** If the clock has not been set, even if the TIMER/CLOCK button is pressed you cannot select the REC Timer.

- 2. Press the TIMER/CLOCK button again.**  
The display changes to the On Time display.

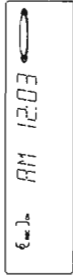

- 3. Set the time you want the Unit to be turned on.**

Set the time by adjusting the MULTI CONTROL stick left or right in the same way you set the time for the clock. Press the SET button to set the on time.

- 4. Set the time you want the Unit to be turned off.**

Set the time by adjusting the MULTI CONTROL stick left or right in the same way you set the time for the clock. Press the SET button to set the off time.

- 5. Select the radio station you want to record.**

Set the radio station you want to record by adjusting the MULTI CONTROL stick up or down.

- 6. Press the SET button.**

The "REC" indicator changes from a blinking display to a steady display. The ON TIME, OFF TIME, and preset channel number are displayed then the display reverts to the previous display, before the Timer was set.

Turn the power off if you made the timer settings with the power turned on.

- A few seconds before the start time for the recording, the CA-D661T automatically turns on the power, and "REC TIMER" blinks on the display. When the start time is reached, recording starts using the selected source. After the finish time for the recording is reached, the power is automatically turned off again.
- If a button is pressed when the REC Timer is operating, recording continues but the timer is cancelled.

**Before the Timer Starts**

- Check that tape direction is correct. This is important especially when Reverse Mode is off.
- Set Reverse Mode on if you want to record on both sides of the tape.
- The VOLUME control is automatically set to 0 when REC Timer is recording.



### Timer Priority

Since each timer can be set independently, you may wonder what happens if the settings overlap. Here are the priorities for each timer:

- The REC Timer always has priority. This means that:
  - If another timer is set to come on during a time when the REC Timer is operating, the other timer just won't come on at all, so you will always get the entire program on tape.
  - If the REC Timer is set to come on while another timer is operating, the other timer will shut off 10 seconds before the REC Timer is set to turn on, and the REC Timer will then take over.
- The SLEEP Timer has the least priority. This means that if the SLEEP Timer is set while the DAILY Timer is operating, the DAILY Timer settings are cancelled. However, if the DAILY Timer is set to come while the SLEEP Timer is operating, the SLEEP Timer setting will be cancelled and the Unit will use the settings from the DAILY Timer.

Example 1

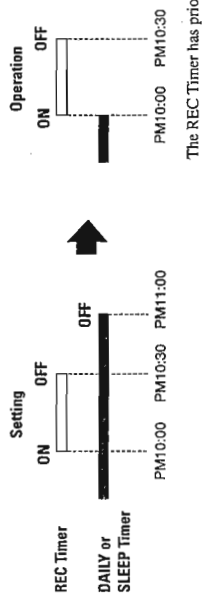

Example 2

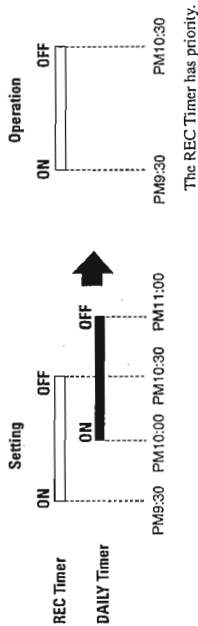

It is very easy, and can be very disappointing, to forget to put in a tape, or to accidentally leave a tape in Deck B you don't want recorded over. Although this happens to almost everyone at one time or another, we hope it won't happen to you!

#### To Change the Recording Timer Setting

To change the settings for the REC Timer, repeat the setting procedure from the beginning.

#### Turning the REC Timer On and Off

Once the REC Timer has been used to record a source, the setting is maintained but the Timer is set to OFF.

To record at the same time again, press the TIMER/CLOCK button until "REC" appears in the display, then press the SET button. The ON TIME, OFF TIME, channel frequency, and preset channel number are displayed then the display reverts to the previous display, before the Timer was set.

To turn the REC Timer off before the timer starts, press the TIMER/CLOCK button until "REC" appears in the display, then press the CANCEL button. "OFF" appears in the display and the REC indicator goes out.

**CAUTION:** If the CA-D661T is unplugged, or a power failure occurs, the timer setting will be erased in a few days. If the settings are erased in this way, reset the timer settings.

### Setting the SLEEP Timer

Use the Sleep Timer to turn the Unit off after a certain number of minutes when it is playing. By setting this timer, you can fall asleep to music and know your Unit will turn off by itself rather than play all night.

□ You can only set the Sleep Timer when the Unit is on and a source is playing.

To set the SLEEP Timer, follow this procedure:

1. With the CA-D661T on and a source playing, press the SLEEP button on the Remote Control. The message "SLEEP" appears on the display.

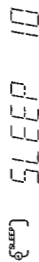

2. Set the length of time you want the source to play before shutting off.

□ Each time you press this button while the "SLEEP" indicator is blinking, it changes the number of minutes shown on the display in this sequence:

→ 10 → 20 → 30 → 60 → 90 → 120 → Cancelled → (back to the beginning)

When the number of minutes you want shows on the display, just wait 5 seconds until the indicator stops blinking, and is lighted steadily.

The Unit is now set to turn off after the number of minutes you set.

#### To Change the SLEEP Timer Setting

Press the SLEEP button until the number of minutes you want appears on the display.

#### To Cancel the SLEEP Timer Setting

Press the SLEEP button until the "SLEEP" indicator goes off on the display.

Turning off the Unit also cancels the SLEEP Timer.

## Care And Maintenance

### Compact Discs

Handle your compact discs, cassette tapes, and Cassette Deck carefully, and they will last a long time.

- Remove the CD from the case by holding it at the edges while pressing the center hole lightly.
- Do not touch the shiny surface of the CD, or bend the CD.
- Put the CD back in its case after use to prevent warping. Be careful not to scratch the surface of the CD when placing it back in the case.
- Avoid exposure to direct sunlight, temperature extremes, and moisture.
- A dirty CD may not play correctly. If a CD does become dirty, wipe it with a soft cloth in a straight line, from center to edge.



**CAUTION: Do not use any solvent (for example, conventional record cleaner, spray thinner, benzine, etc.) to clean a CD.**

### Moisture Condensation

- Moisture may condense on the lens inside the Unit in the following cases:
- After starting the heating in the room.
  - In a damp room.
  - If the unit is brought directly from a cold to a warm place. Should this occur, the Unit may malfunction. In this case, leave the unit turned on for a few hours until the moisture evaporates, unplug the AC power cord, and then plug it in again.



### General Notes

- In general, you will have the best performance by keeping your tapes, CDs, and the mechanism clean.
- Store tapes and CDs in their cases, and keep them in cabinets or on shelves.
  - Keep the Cassette Deck's tape holder and the CD trays closed when not in use.

### Cassette Tapes



- If the tape is loose in its cassette, take up the slack by inserting a pencil in one of the reels and rotating.
- If the tape is loose, it may get stretched, cut, or caught in the cassette.
- Do not touch the tape surface.



- Do not store the tape:
  - In dusty places
  - In direct sunlight or heat
  - In moist areas
  - On a TV or speaker
  - Near a magnet

### Cassette Deck

- If the heads, capstans, and pinch-rollers of the Cassette Deck become dirty, the following will occur:
  - Loss of sound quality
  - Discontinuous sound
  - Fading
  - Incomplete erasure
  - Difficulty recording
- Clean the heads, capstans, and pinch-rollers using a cotton swab moistened with alcohol.

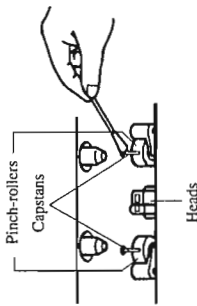

- If the heads become magnetized, the Unit will produce noise or lose high frequencies.
- To demagnetize the heads, turn off the Unit, and use a head demagnetizer (available at electronics and record shops).

## Troubleshooting

- If you are having a problem with your CA-D661T, check this list for a possible solution before calling for service.
- If you cannot solve the problem from the hints given here, or the Unit has been physically damaged, call a qualified person, such as your dealer, for service.

Symptom	Possible Cause	Action
No sound is heard.	Connections are incorrect, or loose.	Check all connections and make corrections. (See pages 4 - 5.)
Unable to record.	Cassette record protect tabs are removed.	Cover holes on back edge of cassette with tape.
Poor radio reception	<ul style="list-style-type: none"> <li>• The antenna is disconnected.</li> <li>• The AM Loop Antenna is too close to the Unit.</li> <li>• The FM Wire Antenna is not properly extended and positioned.</li> </ul>	<ul style="list-style-type: none"> <li>• Re-connect the antenna securely.</li> <li>• Change the position and direction of the AM Loop Antenna.</li> <li>• Extend FM Wire Antenna to the best reception position.</li> </ul>
The CD skips.	The CD is dirty or scratched.	Clean or replace the CD.
Unable to operate the Remote Control.	<ul style="list-style-type: none"> <li>• The path between the Remote Control and the sensor on the Unit is blocked.</li> <li>• The batteries have lost their charge.</li> </ul>	<ul style="list-style-type: none"> <li>• Remove the obstruction.</li> <li>• Replace the batteries.</li> </ul>
The CD tray cannot be opened.	The main AC power cord is not plugged in.	Plug in the AC power plug.
The CD does not play.	The CD is upside down.	Put the CD in with the label side up.
Operations are disabled.	The built-in microprocessor has malfunctioned due to external electrical interference.	Unplug the Unit then plug it back in.
The cassette door cannot be opened.	During tape playing, the power cord was unplugged.	Plug in the power cord, press the POWER button, and then the <b>▲</b> button.

# Description of ICs

## ■ MN172412JAAW( IC902) : TUNER / DISPLAY Controller

### 1. Terminal layout

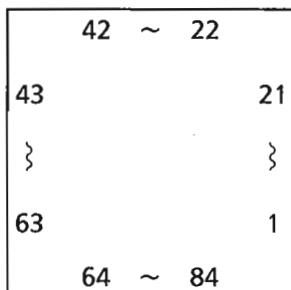

### 2. Terminal Function

Pin No.	Symbol	I/O	Functions and Operations	Pin No.	Symbol	I/O	Functions and Operations
1	7G	O	FL grid control	49	RDS RST	I	Reset signal from IC
2	8G	O	FL grid control	50	/TUNED	I	TUNED indication control
3~15	P1~P13	O	FL anode control	51	/STEREO	I	STEREO indication control
16	P14	O	FL anode control	52	MUTE	O	Muting of tuner sound
17	P15	O	FL anode control	53	DCSOUT	O	Compulink signal output
18	P16	O	FL anode control	54	DCSIN	I	Compulink signal input
19	P20	O	FL anode control	55	CS2	I	chip select terminal input
20	P19	O	FL anode control	56	KI1	I	Key matrix input
21	P18	O	FL anode control	57	KI2	I	Key matrix input
22	P17	O	FL anode control	58	KI3	I	Key matrix input
23	-BP	--	Power supply for FL display	59	KI4	I	Key matrix input
24	P36	O	FL anode control	60	IFDATA	I	Data from PLL synthesizer
25	P35	O	FL anode control	61	CE	O	Chip enable signal for PLL synthesizer
26	P34	O	FL anode control	62	CK	O	Clock for PLL synthesizer
27	P33	O	FL anode control	63	TUDATA	O	Data for PLL synthesizer
28	P32	O	FL anode control	64	CS1	I	chip select terminal input
29	P31	O	FL anode control	65	C-REQ	I	Communication request data to IC301
30	P30	O	FL anode control	66	C-CLK	O	Communication data clock to IC301
31	P29	O	FL anode control	67	C-DATA	O	Communication data to IC301
32	P28	O	FL anode control	68	/RESET	I	RESET signal input
33	P27	O	FL anode control	69	GND	--	Connected to GND
34	P26	O	FL anode control	70	X1	--	Non connection
35	P25	O	FL anode control	71	X2	--	Connected to GND
36	P24	O	FL anode control	72	OSC2	I/O	Clock oscillation terminal
37	P23	O	FL anode control	73	OSC1	I/O	Clock oscillation terminal
38	P22	O	FL anode control	74	VDD	---	Power supply (+ B5V)
39	P21	O	FL anode control	75	T-REQ	I	Request signal to IC901
40	FOUT	O	Clock frequency	76	T-CLK	O	Clock signal to IC901
41	SPISTB	O	Strobe signal for IC303	77	T-DATA	O	Data for IC901
42	SPIDT1	O	Data input from IC303	78	NC	--	Non connection
43	SPIDTO	O	Data output for IC303	79	1G	O	FL grid control
44	SPICSB	O	Chip select output for IC303	80	2G	O	FL grid control
45	RDS CK	O	Clock input from IC	81	3G	O	FL grid control
46	RDS DATA	O	Data signal from IC	82	4G	O	FL grid control
47	RDS RST	O	Reset signal for IC	83	5G	O	FL grid control
48	/TUINH	I	Inhibit signal Input	84	6G	O	FL grid control

## ■ MN17P3222JAAX( IC301) : DECK/CD Controller

## 1. Terminal layout

42 ~ 22
43                      21
}                              }
63                              1
64 ~ 84

## 3. Terminal Function

Pin No.	Symbol	I/O	Functions and Operations	Pin No.	Symbol	I/O	Functions and Operations
1	/APACK	I	APACKswitch detect input	49	/RESTSW	I	Traverse REST sw input
2	AEQ	O	It is "L" when CrO2 tape is in deck A	50		--	Connected to GND
3	DECKAI	O	DECKA indicator control	51		--	Connected to GND
4	DECKBI	O	DECKB indicator control	52	/RST	O	CD Lsi reset signal output
5		--	Non connection	53	MLD	O	Command load signal output to CD Lsi
6		--	Non connection	54	MDATA	O	Command data output to CD Lsi
7	RECI	O	Indication control	55	MLCK	O	Command clock signal output to CD Lsi
8	PON IND	O	Power indicator control	56	DATA	O	Communication data to changer $\mu$ -com
9	DISC1IND	O	DISC1 indicator control	57	SCK	O	Communication clock signal to changer $\mu$ -com
10	DISC2IND	O	DISC2 indicator control	58	CHST	I	Strobe signal to changer $\mu$ -com
11	DISC3IND	O	DISC3 indicator control	59	REQ1	I	Request signal to changer $\mu$ -com
12	PBEQ	O	Play back	60		--	Connected to GND
13	MSIN	I	music scan signal input	61		--	Connected to GND
14	NR	O	NR control signal	62		--	Connected to GND
15	/CAPN	O	Capstan (ON/OFF) control	63	CS	--	Connected to GND
16	BPLZ	O	B mecha. solenoid control	64		--	Connected to GND
17	APLZ	O	A mecha. solenoid control	65		--	Connected to GND
18		--	Connected to GND	66		--	Connected to GND
19		--	Non connection	67		--	Connected to GND
20	BMT	O	It is 'H' when Deck B is not playing	68	/RESET	I	CD reset signal input
21	OMT	O	Deck PB Mute control signal	69	GND	--	Connected to GND
22	RMT	O	Recording mute signal output	70	NC	--	Non connection
23		--	Non connection	71	GND	--	Connected to GND
24	/PB/REC	O	Rec. P.B select signal output	72	OSC	-I	Osillation terminal
25	REC	O	It is "H" when recording	73	OSC	---	Osillation terminal
26	BIAS	O	REC bias ON/OFF control	74	VDD	---	+ 5V
27~39		--	Connected to GND	75	DCS IN	I	DCS signal input
40	C-REQ	O	Communication request data output to IC902	76	DCS OUT	O	DCS signal output
41	C-CLK	I	Clock signal input from IC902	77	APLS	I	A mech. reel pulse input
42		--	Non connection	78	BEQ	O	Play equalizer control
43	C-DATA	I	Command data output to IC902	79	/PSWB	I	B mech. play switch input
44		--	Connected to GND	80	BPLS	I	B mech. pranger control output
45	SQCK	O	Outside lock for sub-code Q register output	81	/FREC	I	FREC switch detect input
46	SUBQ	I	Sub code and Q register signal input	82	/RREC	I	RREC switch detect input
47	LSION	O	CD Lsi on signal output	83	/BPACK	I	BPACKswitch detect input
48	STAT	O	STATUS signal (CRC,CUE,CLVS,TTSTOP,ECLV,SQOK)	84	/PSWA	O	A mech. play switch input



■ HD404719A71FS( IC901) : AMP Controller

1. Terminal layout

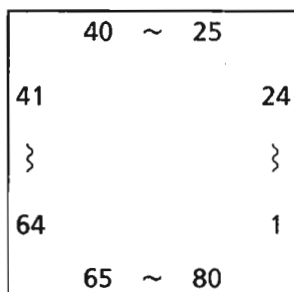

2. Terminal Function

Pin No.	Symbol	I/O	Functions and Operations	Pin No.	Symbol	I/O	Functions and Operations
1	IN6	I	Key input (A/D convert)	40		--	Not use
2	/INH	I	Inhibit signal input	41	CDI	O	CD indication control
3	/PRT	I	Protector signal input	42	TUI	O	TUNED indication control
4	AD GND	--	Connected to GND	43	TAPEI	O	TAPE indication control
5	RESET	I	Reset signal input	44	VCRI	O	VCR indication control
6	OSC1	I/O	Clock oscillation terminal	45		--	Not use
7	OSC2	I/O	Clock oscillation terminal	46	APOI	O	APO indication control
8	GND	--	Connected to GND	47	BASSI	O	BASS indication control
9		--	Connected to GND	48	STUNDBYI	O	STNDBY indication control
10		--	Not use	49		--	Connected to GND
11	/TEST	O	Pull up	50~57		--	Not use
12	VCC	--	Power supply	58	SCK	O	Clock for IC401
13	RDS	O	Chip select terminal	59	SDA1	O	Data for IC401
14	PROLOGIC	O	Chip select terminal	60		--	Not use
15	KARAOKE	O	Chip select terminal	61	/RMIN	I	Remote control signal input
16	ECHO	O	Chip select terminal	62		--	Not use
17	SABASS	O	Chip select terminal	63	T-DATA	I	Communication data from IC302
18	HPIN	I	Head phone detect	64	T-REQ	O	Communication request data to IC302
19	CDRESET	O	CD servo Lsi reset signal output	65	T-CLK	O	Communication data clock from IC302
20	/TUINH	O	Tuner Inhibit signal output	66~68		--	Not use
21	TURESET	O	Tuner reset signal output	69	JOG2	I	Input 2 Jog pulse
22	DCSIN	I	Compulink signal data input	70	JOG1	I	Input 1 Jog pulse
23	DCSOUT	O	Compulink signal data output	71		--	Not use
24	ACO	O	Power supply control signal	72	SMUTE	O	Source Mute control signal
25	CONT.A	O	KARAOKE on/off control signal	73	ECHO2	O	Echo2 signal output
26,27		--	Not use	74	ECHO1	O	Echo1 signal output
28	RERAY1	O	Speaker relay on/off signal output	75	AD Vcc	---	Power supply ( + B5V)
29		--	Not use	76	IN1	I	Key input (A/D convert)
30	SURR	O	Surrund ON/OFF control signal	77	IN2	I	Key input (A/D convert)
31		--	Not use	78	IN3	I	Key input (A/D convert)
32~38		--	Not use	79	IN4	I	Key input (A/D convert)
39		--	Not use	80	IN5	I	Key input (A/D convert)

■ MN35510 (IC603) : DIGITAL SERVO & DIGITAL SIGNAL PROCESSER

1. Terminal Layout

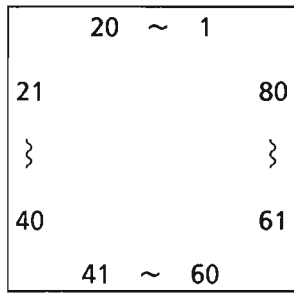

2. Block Diagram

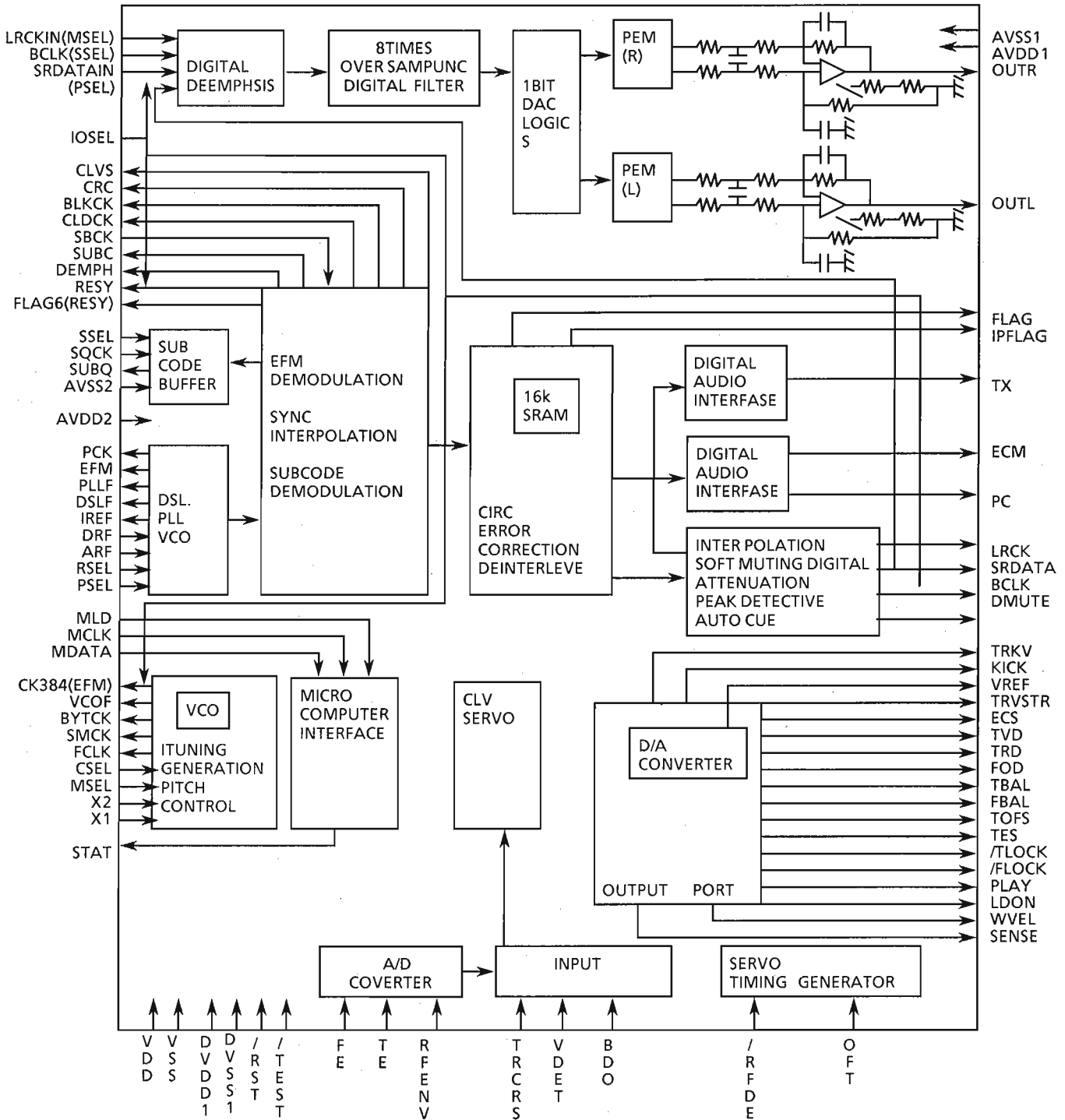

## 3. Description

Pin No.	symbol	I/O	Description	Pin No.	symbol	I/O	Description
1	BCLK	O	Bit clock output pin SRDATA	41	TES	O	Tracking error shunt signal output (H;shunt)
2	LRCK	O	L/R distinction signal output	42	PLAY	—	Not used
3	SRDATA	O	Serial data output	43	WVEL	—	Not used
4	DVDD1	—	Power supply(Digital)	44	ARF	I	RF signal input
5	DVSS1	—	Connected to GND(Digital)	45	IREF	I	Reference current input pin
6	TX	O	Not use	46	DRF	—	Connected to GND
7	MCLK	I	$\mu$ -com command clock signal input (Data is latched at signal's rising point)	47	DSL F	I/O	Loop filter pin for DSL
8	MDATA	I	$\mu$ -com command data input	48	PLL F	I/O	Loop filter pin for PLL
9	MLD	I	$\mu$ -com command load signal input	49	VCOF	—	Connected to GND
10	SENSE	O	Not used	50	AVDD2	—	Power supply (Analog)
11	FLOCK	O	Not used	51	AVSS2	—	Connected to GND(Analog)
12	TLOCK	O	Not used	52	EFM	—	Not used
13	BLKCK	O	Subcode · block · clock signal output	53	PCK	—	Not used
14	SQCK	I	Outside lock for sub-code Q resister input	54	PDO	—	Not used
15	SUBQ	O	Sub-code Q-code output	55	SUBC	—	Not used
16	DMUTE	—	Connected to GND	56	SBCK	—	Not used
17	STATUS	O	Status signal (CRC,CUE,CLVS,TTSTOP,ECLV,SQOK)	57	VSS	—	Connected to GND(for X'tal cscillation circuit)
18	RST	I	Reset signal input (L :Reset)	58	X1	I	Input of 16.9344MHz X'tal oscillation circuit
19	SMCK	—	Not used	59	X2	O	Output of X'tal oscillation circuit
20	PMCK	—	Not used	60	VDD	—	Power supply(for X'tal cscillation circuit)
21	TRV	O	Traverse enforced output	61	BYTCK	—	Not used
22	TVD	O	Traverse drive output	62	CLDCK	—	Not used
23	PC	—	Not used	63	FCLK	—	Not used
24	ECM	O	Spindle motor drive signal (Enforced mode output) 3-State	64	IPPLAG	—	Not used
25	ECS	O	Spindle motor drive signal (Servo error signal output)	65	FLAG	—	Not used
26	KICK	O	Kick pulse output	66	CLVS	—	Not used
27	TRD	O	Tracking drive output	67	CRC	—	Not used
28	FOD	O	Focus drive output	68	DEMPH	—	Not used
29	VREF	I	Reference voltage input pin for D/A output block(TVD,FOD,FBAL,TBAL)	69	RESY	—	Not used
30	FBAL	O	Focus Balance adjust signal output	70	IOSEL	—	Pull up
31	TBAL	O	Tracking Balance adjust signal output	71	TEST	—	Pull up
32	FE	I	Focus error signal input(Analog input)	72	AVDD1	—	Power supply (Digital)
33	TE	I	Tracking error signal input(Analog input)	73	OUT L	O	Lch audio output
34	RF ENV	I	RF envelope signal input(Analog input)	74	AVSS1	—	Connected to GND
35	VDET	I	Vibration detect signal input(H : detect)	75	OUT R	O	Rch audio output
36	OFT	I	Off track signal input(H : off track)	76	RSEL	—	Pull up
37	TRCRS	I	Track cross signal input	77	CSEL	—	Connected to GND
38	RFDET	I	RF detect signal input (L : detect)	78	PSEL	—	Connected to GND
39	BDO	I	BDO input pin (H : drop out)	79	MSEL	—	Connected to GND
40	LDON	O	Laser ON signal output (H : on)	80	SSEL	—	Pull up (+ 5V)

■ AN8806SB (IC601) : RF & SERVO AMP

1. Terminal Layout

PD	1	36	PDAC
LD	2	35	PDBD
LDON	3	34	PDE
LDP	4	33	PDF
VCC	5	32	PDER
RF-	6	31	PDFR
RFOUT	7	30	TBAL
RF IN	8	29	FBAL
C.AGC	9	28	FE-
ARF	10	27	FE OUT
C.ENV	11	26	TE-
C.EA	12	25	TE OUT
CS BDO	13	24	CROSS
BDO	14	23	TE BPF
CS BRT	15	22	VDET
OFTR	16	21	LD OFF
/NRFDET	17	20	VREF
GND	18	19	ENV

2. Block Diagram

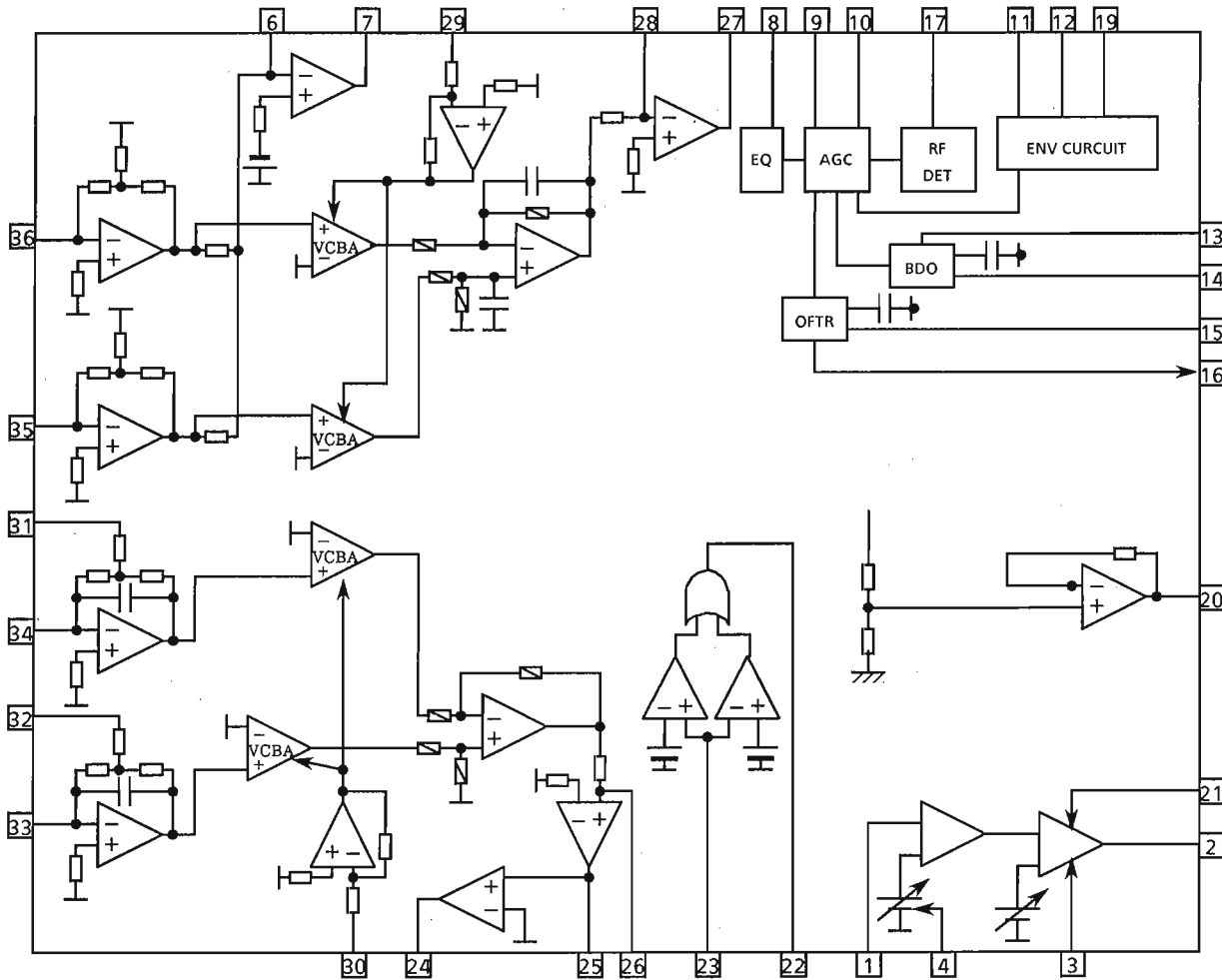

## 3. Functions

Pin No.	Symbol	I/O	Functions and operations
1	PD	I	APC amp input terminal
2	LD	O	APC amp output terminal
3	LD ON	I	APC ON/OFF control terminal
4	LDP	--	Connected to ground
5	VCC	--	Power supply
6	RF-	I	Inverse input pin for RF amp
7	RF OUT	O	RF amp output
8	RF IN	I	RF input
9	C.AGC	I/O	Connecting pin of AGC loop filter
10	ARF	O	RF output
11	C.ENV	I/O	A capacitor is connected to this terminal to detect the envelope of RF signal
12	C.EA	I/O	A capacitor is connected to this terminal to detect the envelope of RF signal
13	CS BDO	I/O	A capacitor is connected to detect the lower envelope of the RF signal
14	BDO	O	BDO output pin
15	CS BRT	I/O	A capacitor is connected to detect the lower envelope of the RF signal
16	OFTR	O	Of-track status signal output
17	/NRFDET	O	RF detection signal output
18	GND	--	Ground
19	ENV	O	Envelope output
20	VREF	O	Reference voltage output
21	LD OFF	--	Connect to ground
22	VDET	O	Vibration detection signal output
23	TE BPF	I	Input pin of tracking error through BPF
24	CROSS	O	Tracking error cross output
25	TE OUT	O	Tracking error signal output
26	TE-	I	Inverse input pin for tracking error amp
27	FE OUT	O	Output pin of focus error
28	FE-	I	Inverse input pin for focus error amp
29	FBAL	I	Focus balance control
30	TBAL	I	Tracking balance control
31	PDFR	I/O	F I-V amp gain control
32	PDER	I/O	E I-V amp gain control
33	PDF	I	I-V amp input
34	PDE	I	I-V amp input
35	PD BD	I	I-V amp input
36	PD AC	I	I-V amp input

■ LC72131 (IC121) : PLL Synthesizer

1. Terminal Layout

XIN	1	22	XOUT
PLLCE	3	21	VSS
PLLDA	4	19	LPF IN
PLLCK	5	18	PD
IFDATA	6	17	VDD
$\overline{\text{FM}}$	7	16	FM OSC
$\overline{\text{AM}}$	8	15	AM OSC
LW	9	14	
$\overline{\text{AUTO/MONO}}$	10	13	IF REQ
$\overline{\text{FM-LOW}}$	11	12	FM/AM IF

2. Block Diagram

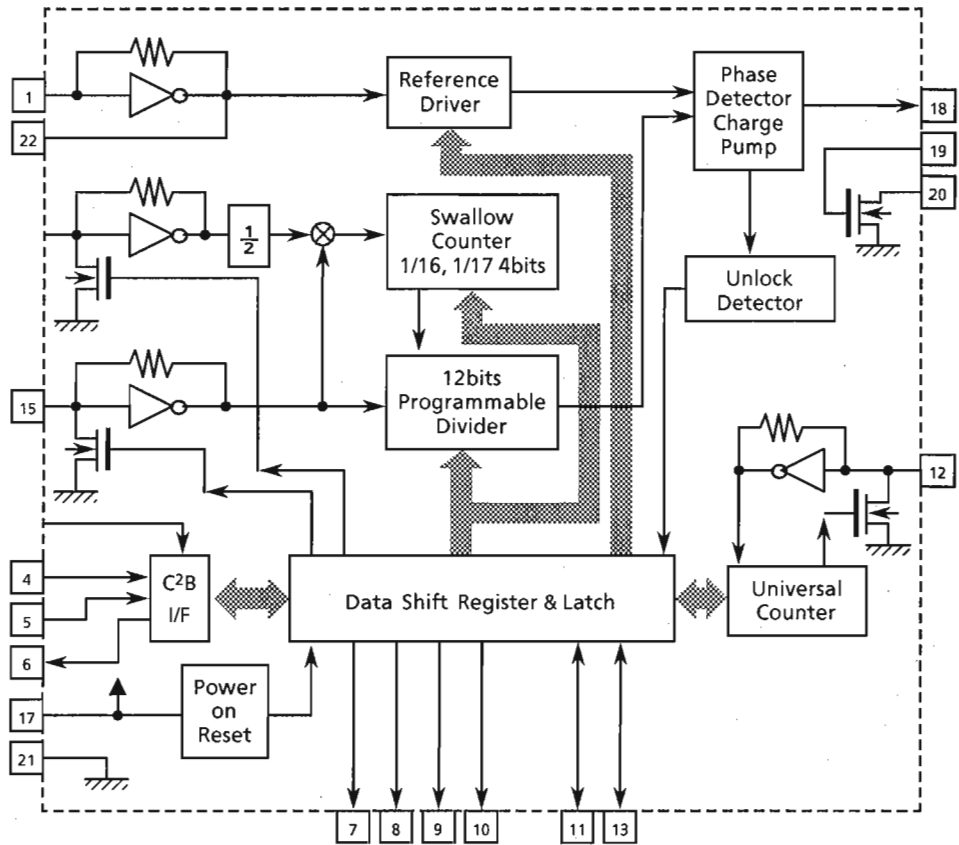

3. Pin Functions

Pin No.	Symbol	I/O	Functions	Pin No.	Symbol	I/O	Functions
1	X in	I	Crystal oscillator (7.2MHz).	12	FM/AM IF	I	Universal counter input
2		--	Not use	13	IF REQ	O	Output the "IF-signal request" to IC102
3	PLLCE	I	Fix the chip enable to "H" when inputting(DI) and outputting (DO) the serial data	14		I	Not use
4	PLLDA	I	Receive the control data from the controller (IC201).	15	AMOSC	I	Input the local oscillator signal of AM.
5	PLLCK	I	This clock is used to synchronize data when transmitting the data of DI and DO.	16	FM OSC	I	Input the local oscillator signal of FM.
6	IFDATA	O	Transmit the data from LC72131 to the controller which is synchronized with CK.	17	VDD	O	This is a terminal of power supply.
7	$\overline{\text{FM}}$	O	It is "L" on FM mode.	18	PD	O	PLL charge pump output : When the local oscillator signal frequency is higher than the reference frequency high level signals will output. When it is lower than the reference frequency, low level signals will output. When it is same as reference frequency signals, it will be floating.
8	$\overline{\text{AM}}$	O	It is "L" on MW mode.	19	LPF IN	I	Transistor used for the PLL active low-pass filter
9	LW	O	It is "L" on LW mode.	20	LPF OUT	O	Transistor used for the PLL active low-pass filter
10	$\overline{\text{AUTO/MONO}}$	O	It is "L" on monaural, "H" on auto.	21	VSS	--	Connected to GND
11	$\overline{\text{POWER}}$	O	Regulator control singal PON "H", STANDBY "L"	22	X out	O	Crystal oscillator (7.2MHz).

LA1837 (IC102) : FM AM IF AMP & detector, FM MPX Decoder

1. Terminal Layout

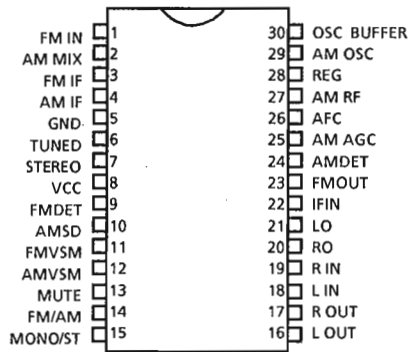

3. Pin Function

Pin No.	Symbol	I/O	Function
1	FM IN	I	This is an input terminal of FM IF Signal.
2	AM MIX	O	This is an output terminal for AM mixer.
3	FM IF	I	Bypass of FM IF
4	AM IF	I	Input of AM IF Signal.
5	GND	-	This is the device ground terminal.
6	/TUNED	O	When the set is tuning ;this terminal becomes "L".
7	STEREO	O	Stereo indicator output. Stereo : "L", Mono : "H"
8	VCC	-	This is the power supply terminal.
9	FM DET	-	FM detect transformer.
10	AMSD	-	AM ceramic filter terminal
11	FM VSM	O	Fix the sensitivity of FM tuned
12	AM VSM	O	Fix the sensitivity of AM tuned
13	MUTE	O/I	When the signal of IF REQ of IC121(LC72131) appear, the signal of FM/AM IF output. //Muting control input.
14	FM/AM	I	Change over the FM / AM input. "H" : FM, "L" : AM
15	MONO/ST	O	Stereo : "H", Mono : "L"
16	L OUT	O	Left channel signal output.
17	ROUT	O	Right channel signal output
18	L IN	I	Input terminal of the Left channel post AMP.
19	R IN	I	Input terminal of the Right channel post AMP.
20	ROUT	O	Mpx Right channel signal output.
21	L OUT	O	Mpx Left channel signal output.
22	IF IN	I	Mpx input terminal.
23	FMOUT	I	Voltage controlled oscillator terminal.
24	AMDET	-	AM low cut adjustment.
25	AM AGC	I	This is an AGC voltage input terminal for AM.
26	AFC	-	This is an output terminal of voltage for FM-AFC.
27	AMRF	I	This is an input terminal for AM RF signal.
28	REG	-	Control of desides the frequency width
29	AM OSC	-	This is a terminal of AM Local oscillation circuit.
30	OSC BUFFER	O	AM Local oscillation Signal output.

2. Block Diagram

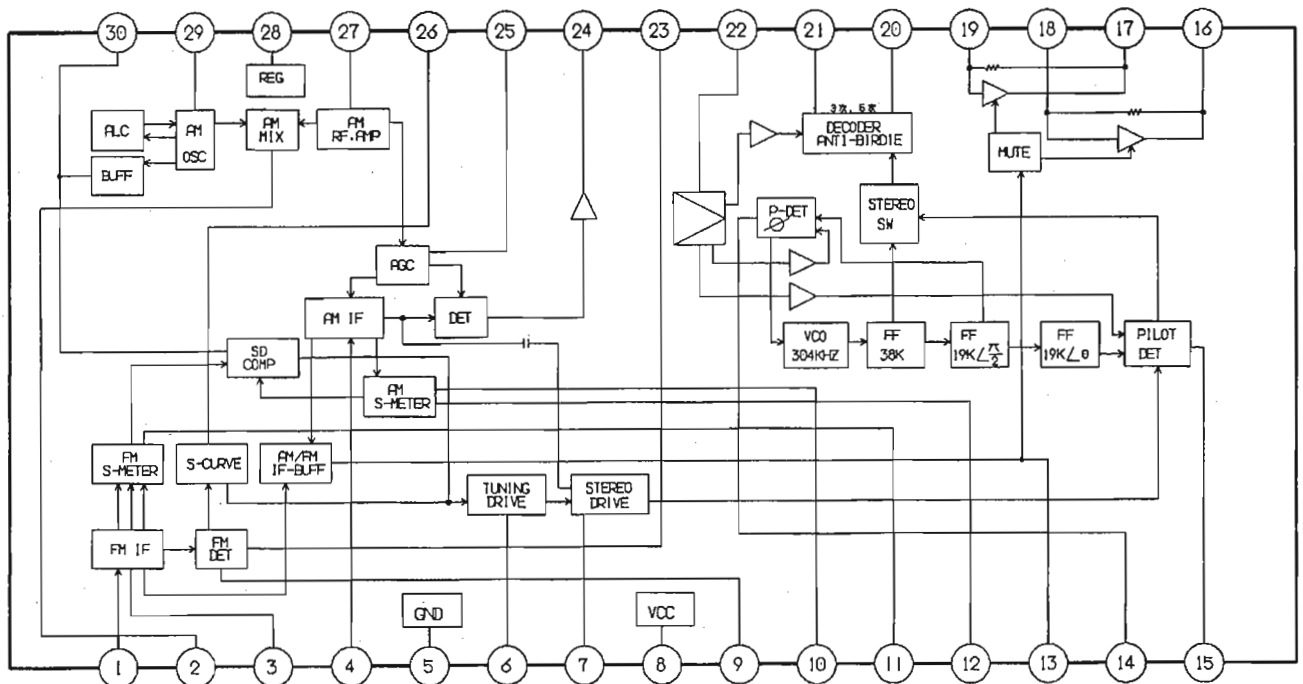

■ UPD65612GB-165(IC801) : Changer Controller

1. Terminal Layout

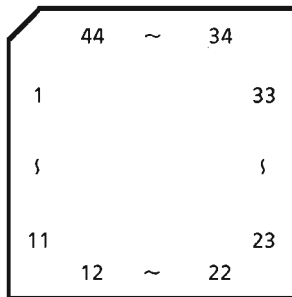

2. Pin Functions

Pin No.	Symbol	I/O	Function	Pin No.	Symbol	I/O	Function
1	NC	--	Non connection	23	2SSW	I	TRAY2 switch input signal
2	NC	--	Non connection	24	1SSW	I	TRAY1 switch input signal
3	NC	--	Non connection	25	NC	--	Non connection
4	OS1I	I	Oscillation terminal	26	CAM0	I	Cam switch input signal for LCAM
5	OS1O	O	Oscillation terminal	27	CAM1	I	Cam switch input signal for LCAM
6	OS2I	I	Oscillation terminal	28	CAM2	I	Cam switch input signal for LCAM
7	OS2O	O	Oscillation terminal	29	CAM3	I	Cam switch input signal for LCAM
8	NC	--	Non connection	30	CAM4	I	Cam switch input signal for RCAM
9	C25IN	I	Connected to C25OUT	31	CAM5	I	Cam switch input signal for RCAM
10	C25OUT	O	Connected to C25IN	32	CAM6	I	Cam switch input signal for RCAM
11	RESET	I	Reset signal input	33	CAM7	I	Cam switch input signal for RCAM
12	REQ	O	Output the "mecha. data request"	34	FIT	O	Connected to C50
13	DATA	I/O	Control, Status data I/O	35	C50	I	Connected to FIT
14	ST	I	Strobe signal input	36	LMUP	O	L motor control signal
15	CKS	I	Clock input	37	LMDWN	O	L motor control signal
16	SELECT	--	Connected to GND	38	C25	--	Non connection
17	GND	--	GND	39	VDD	--	Power supply terminal
18	CK	--	Connected to GND	40	C100	--	Non connection
19	1MSW	I	TRAY1 switch input signal	41	RMUP	O	R motor control signal
20	2MSW	I	TRAY2 switch input signal	42	RMDWN	O	R motor control signal
21	3MSW	I	TRAY3 switch input signal	43	NC	--	Non connection
22	3SSW	I	TRAY3 switch input signal	44	NC	--	Non connection



■ XR1099(IC903) : 7-channel graphic equalizer filter with A/D converter

1. Internal Block Diagram

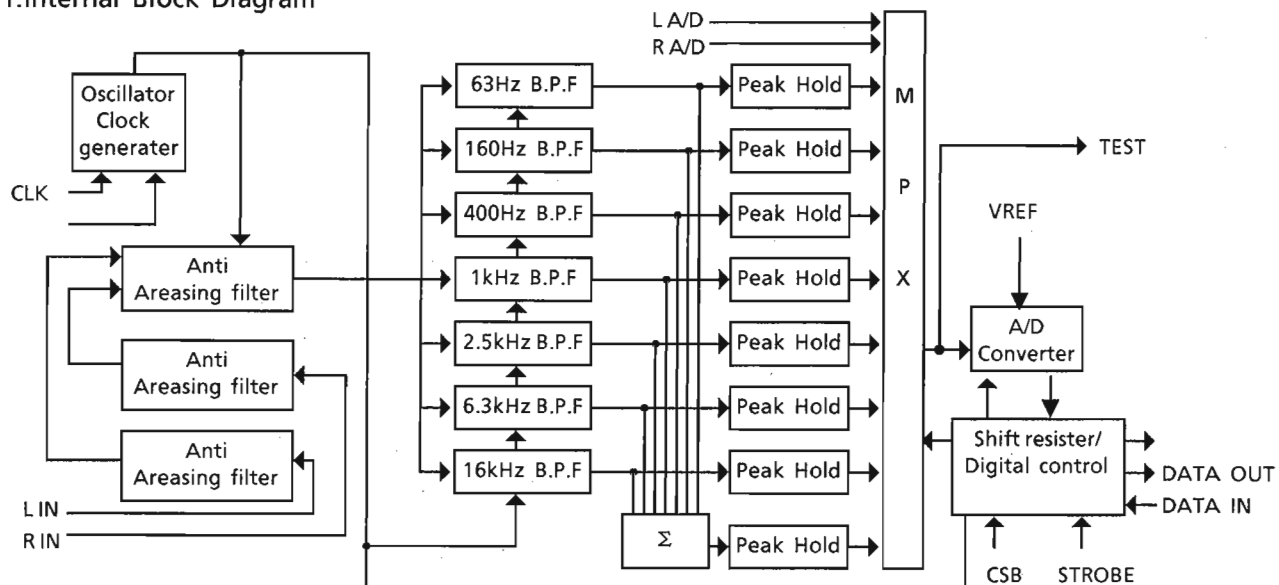

2. Terminal Layout

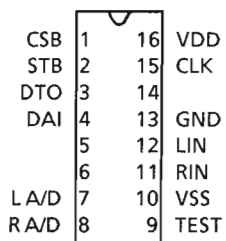

3. Terminal Description

Pin No	Symbol	I/O	Function	Pin No	Symbol	I/O	Function
1	CSB	I	Chip select	9	TEST	--	TEST Terminal
2	STB	I	Strobe signal	10	VSS	--	- 5V
3	SPIDTO	I	Data input	11	RIN	I	Connected to GND
4	SPIDTI	O	Data output	12	LIN	I	Sound signal input
5		--	Non connection	13	GND	--	GND
6		I	Connected to GND	14		I	Connected to GND
7	LA/D	I	Connected to GND	15	CLK	I	A resistor is connected
8	RA/D	I	Connected to GND	16	VCC	--	+ 5V

■ HA12136A(IC231) : NR amplifier

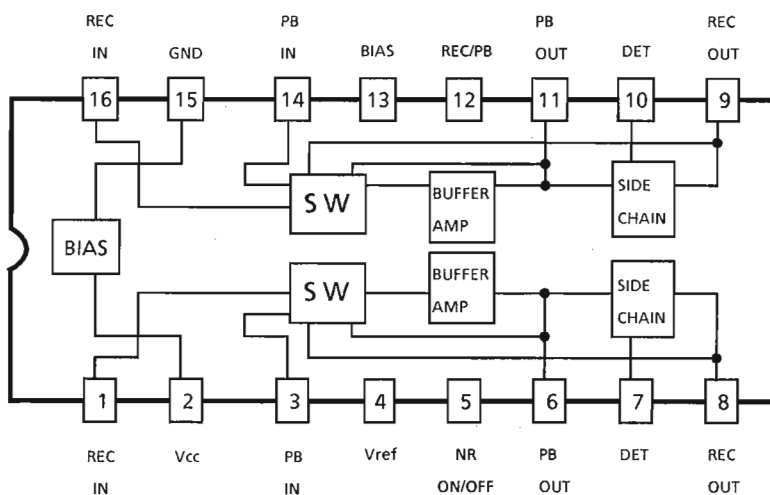

■ BA6897FP(IC602) : 4channel driver

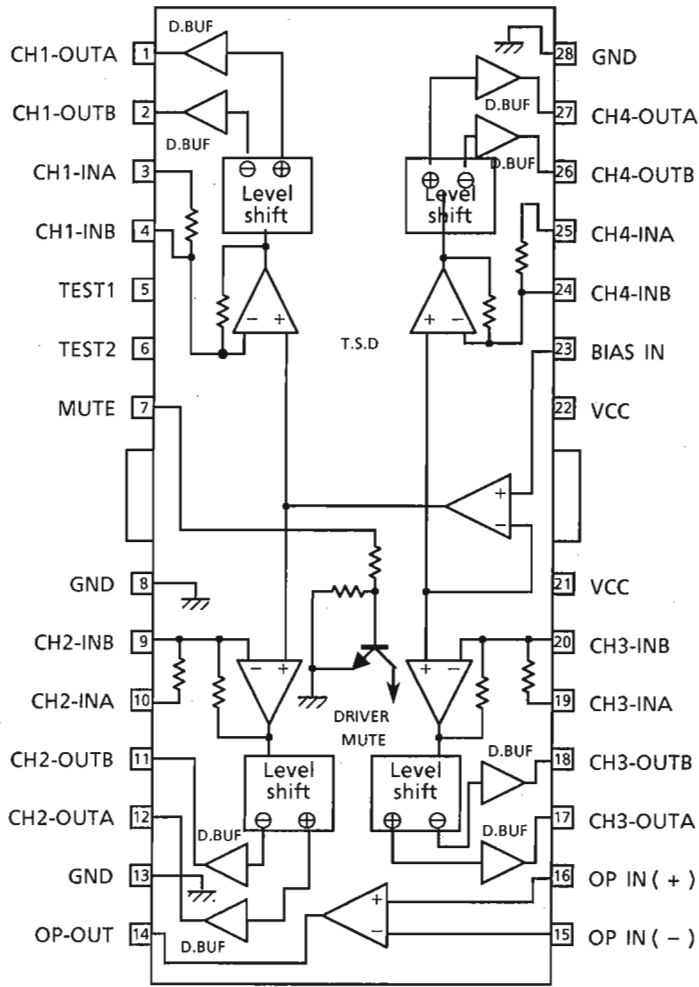

T.S.D : sermal shat down  
 D.BUF : Drive buffer

■ GP1U271X (IC904) : Receiver for remote controller

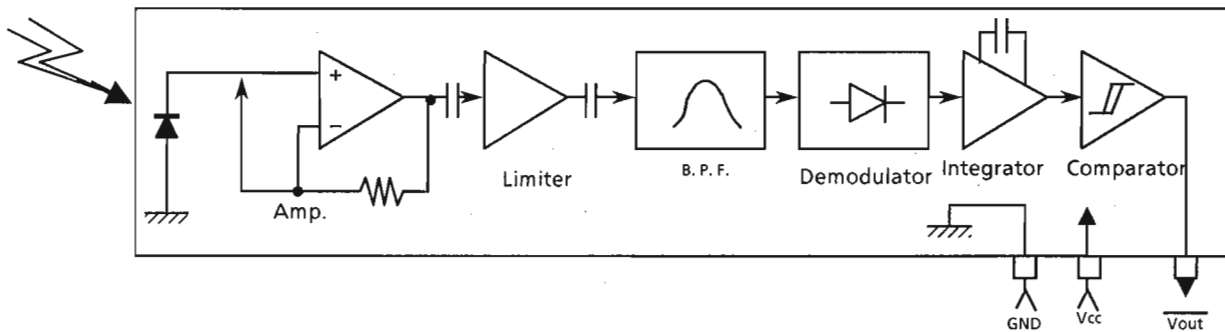

# Internal Connection of the Display

■ QLF0012-001(DI901)

## 1. Terminal Layout

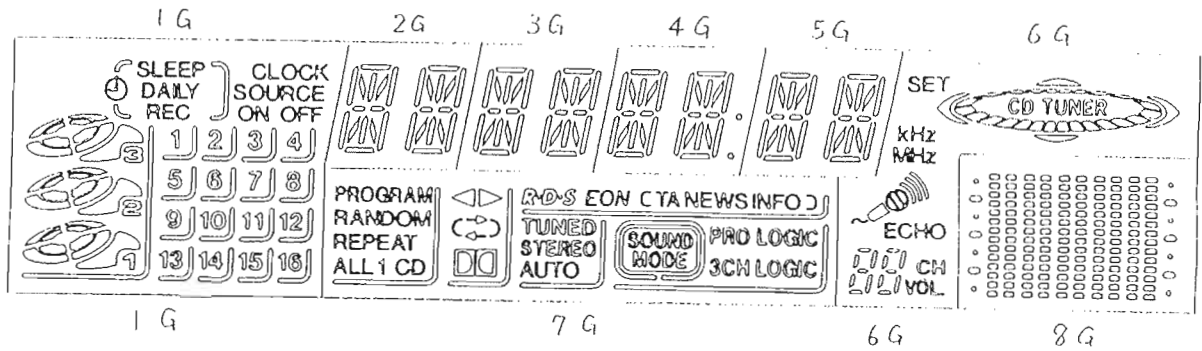

## 2. Segment connection

	1G	2G	3G	4G	5G	6G	7G	8G
P1	9j	-	-	-	-	-	-	5-3
P2	10j	-	-	-	-	-	EON	4-3
P3	11j	4a	4a	4a	4a	6-k	RDS	3-3
P4	12j	4b	4b	4b	4b	6-j	-	2-3
P5	5j	4k	4k	4k	4k	6-e	7-2	1-3
P6	6j	4j	4j	4j	4j	6-f	-	5-2
P7	7j	4h	4h	4h	4h	6-g	7-6	4-2
P8	8j	4f	4f	4f	4f	6-h	7-8	3-2
P9	1j	4g	4g	4g	4g	6-i	7-7	2-2
P10	2j	4m	4m	4m	4m	6-a	7-10	1-2
P11	3j	4c	4c	4c	4c	6-b	7-9	6-1
P12	4j	4n	4n	4n	4n	6-c	7-1	4-1
P13	SOURCE	4p	4p	4p	4p	6-d	CD	3-1
P14	OFF	4r	4r	4r	4r	-	1	2-1
P15	ON	4e	4e	4e	4e	-	-	1-1
P16	CLOCK	4d	4d	4d	4d	-	ALL	S3
P17	18j	-	-	s	-	MHz	REPEAT	1-4
P18	15j	-	-	t	-	-	RANDOM	2-4
P19	14j	-	-	-	-	SET	PROGRAM	3-4
P20	13j	-	-	-	-	kHz	TA	4-4
P21	-	5d	5d	5d	5d	1a	-	5-4
P22	1-a	5e	5e	5e	5e	1b	NEWS	1-5
P23	1-b	5r	5r	5r	5r	1f	INFO	2-5
P24	1-c	5p	5p	5p	5p	1g	-	3-5
P25	2-a	5n	5n	5n	5n	1c	7-5	4-5
P26	2-b	5c	5c	5c	5c	1e	TUNED	5-5
P27	2-c	5m	5m	5m	5m	1d	STEREO	1-6
P28	3-a	5g	5g	5g	5g	CH	AUTO	2-6
P29	3-b	5f	5f	5f	5f	2a	7-3	3-6
P30	3-c	5h	5h	5h	5h	2b	7-11	4-6
P31	S1	5j	5j	5j	5j	2f	-	5-6
P32	-	5k	5k	5k	5k	2g	-	1-7
P33	1-d	5b	5b	5b	5b	2c	SOUND MODE	2-7
P34	REC	5a	5a	5a	5a	2e	7-4	3-7
P35	DAILY	-	-	-	-	2d	PRO LOGIC	4-7
P36	SLEEP	-	-	-	-	VOL	3CH LOGIC	5-7

## 3. Terminal connection

TERMINAL NO.	1	2	3	4	5	6	7	8	9	10	11									
ELECTRODE	F	F	NP	NP	1G	2G	3G	4G	5G	6G	7G									
TERMINAL NO.	12	13	14	15	16	17	18	19	20	21	22	23	24	25	26	27	28	29	30	31
ELECTRODE	8G	NX	1	2	3	4	5	6	7	8	9	10	11	12	13	14	15	16	17	18
TERMINAL NO.	32	33	34	35	36	37	38	39	40	41	42	43	44	45	46	47	48	49	50	51
ELECTRODE	P	P	NX	NX	NX	P	P	P	P	P	P	P	P	P	P	P	P	P	P	P
TERMINAL NO.										52	53	54	55	56	57	58	59	60	61	62
ELECTRODE										P	NX	NX	NX	NX	NX	NX	NP	NP	F	F

Notes F: Filament NP: No Pin  
 G: Grid NX: No Extend Pin  
 P: Anode

# Main parts Layout

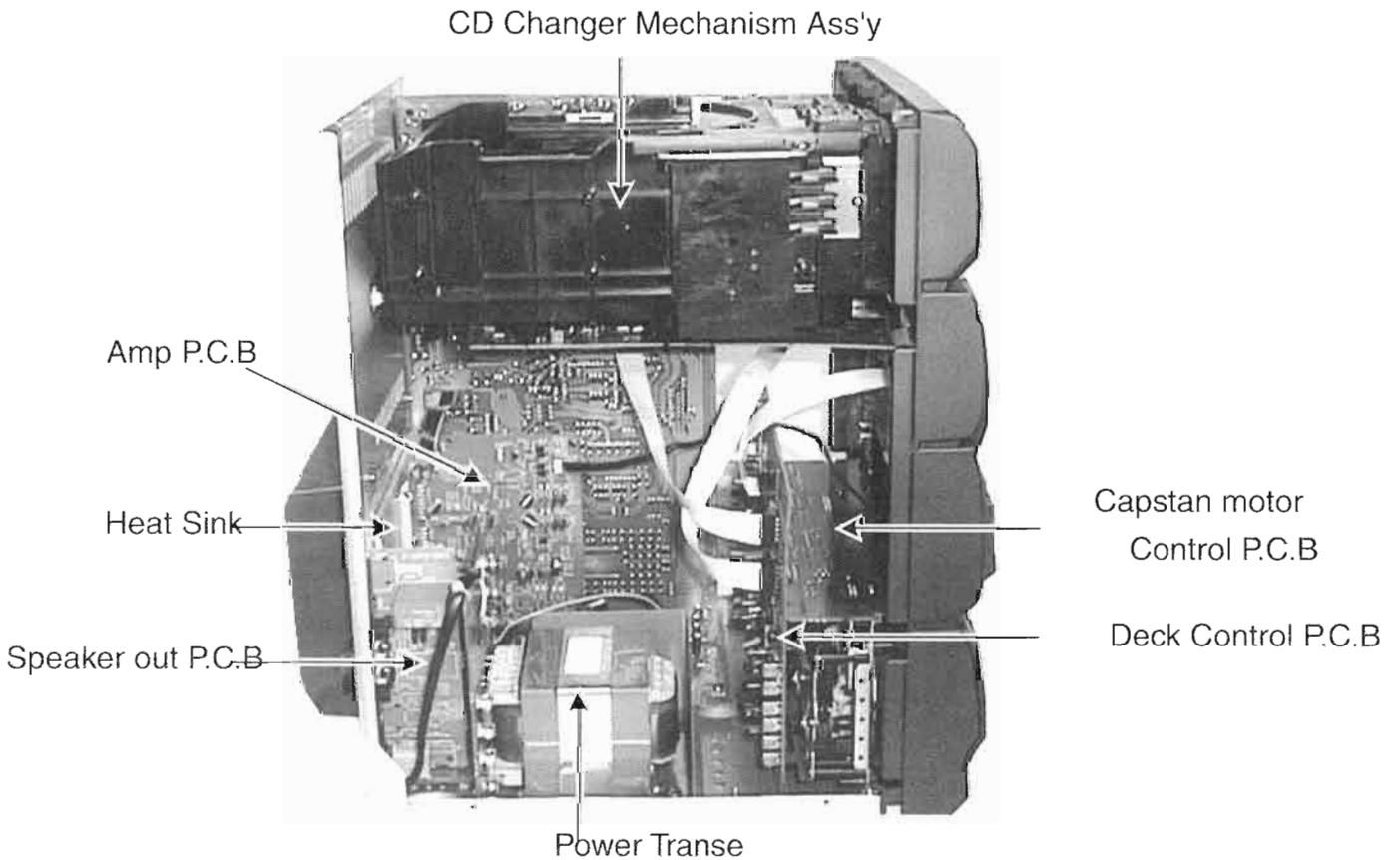
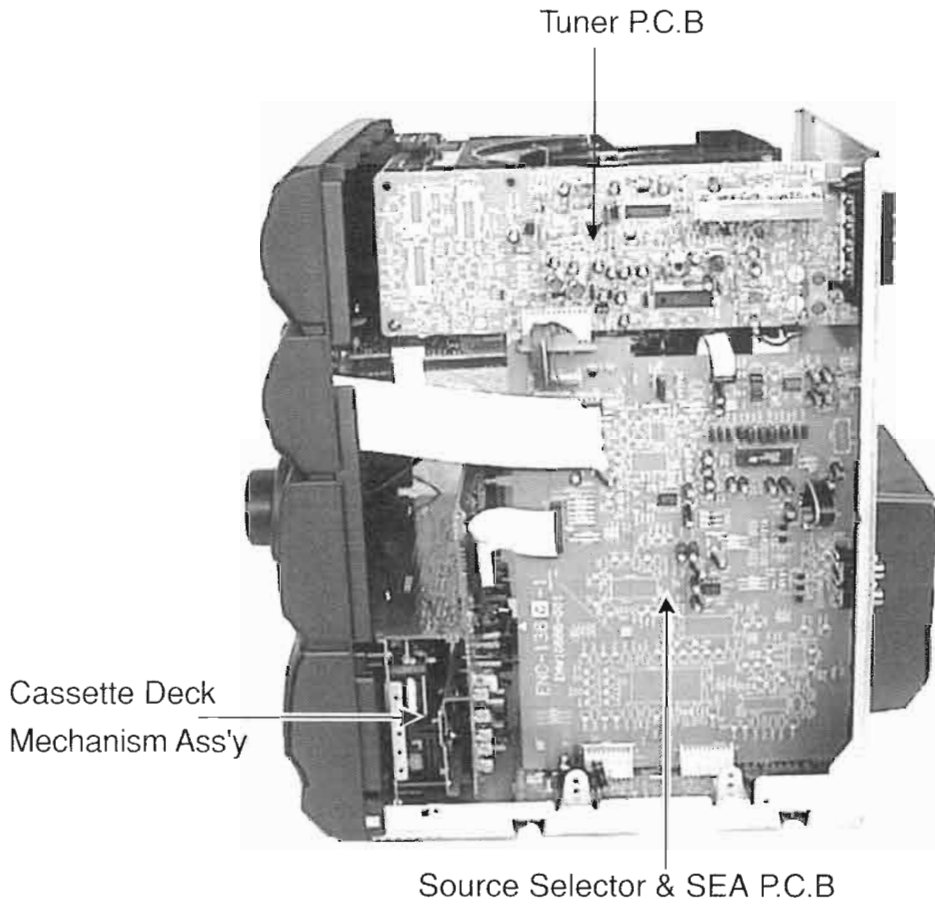

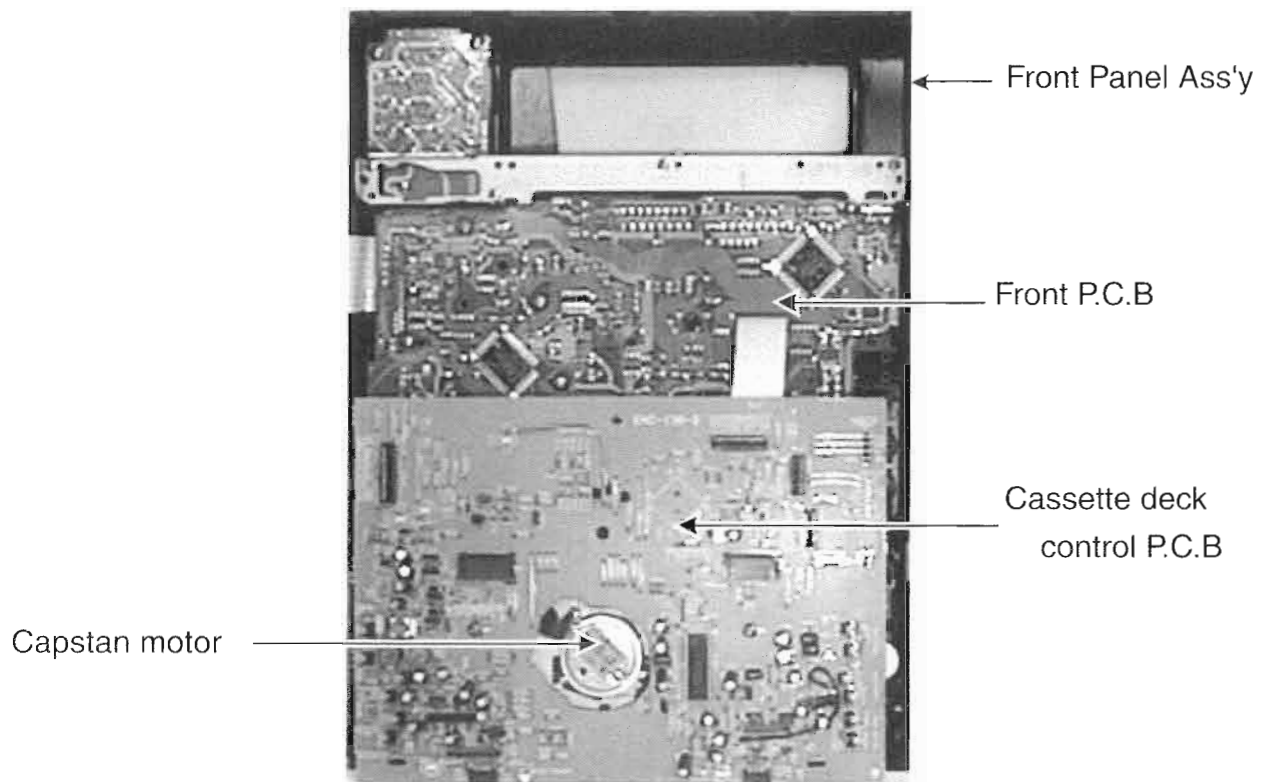
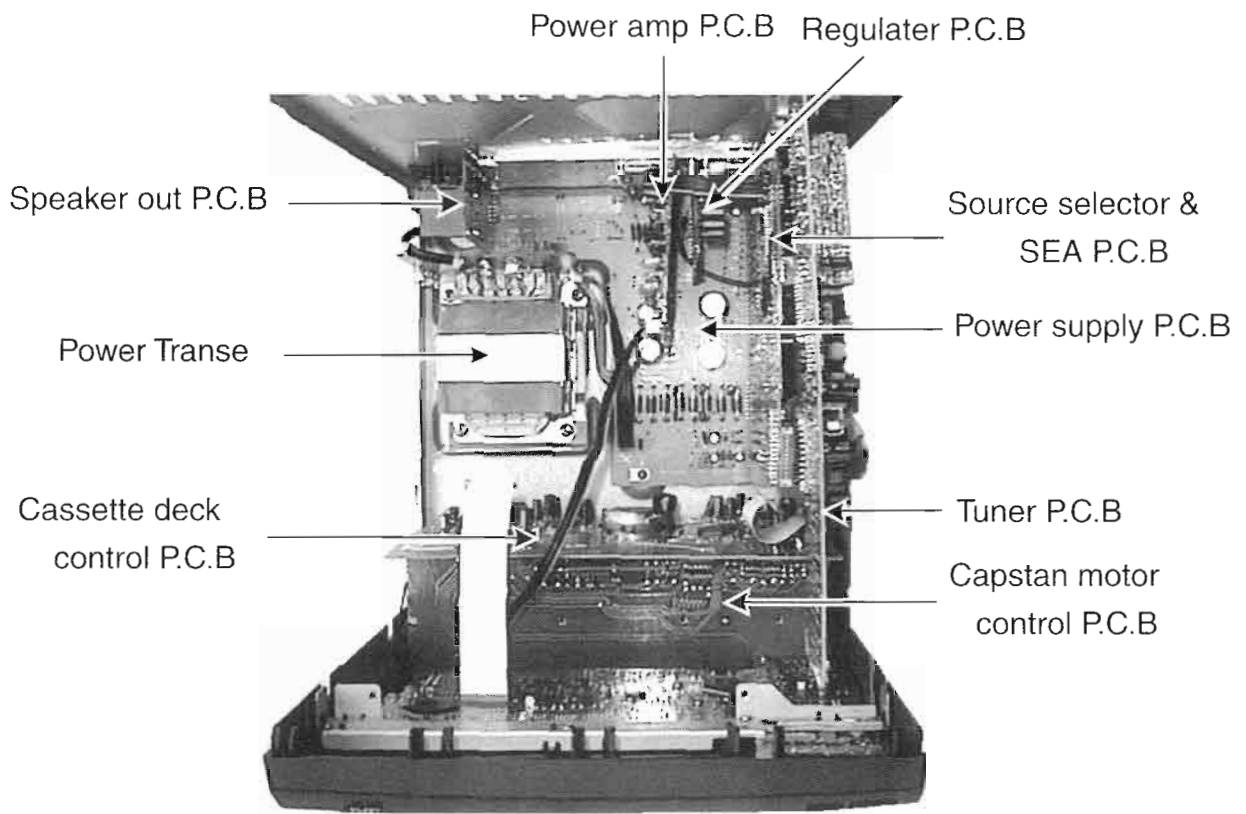

# Disassembly Procedures

## (1) Removing the top cover

1. Remove 2 screws (A) fastening both sides of top cover, and 6 screws (A) fastening the rear side.
2. Remove the top cover.

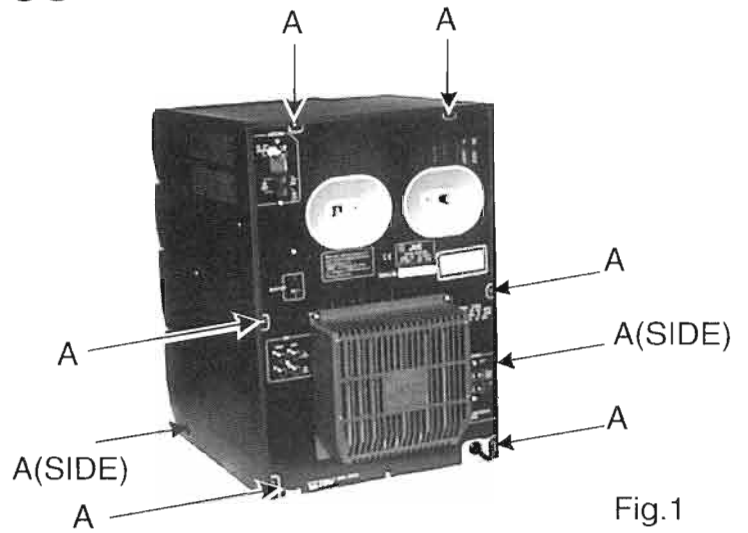

Fig.1

## (2) Removing the changer mechanism ass'y

1. Remove 2 screws(B)fastening up side (Fig. 2).
2. Remove 2 screws(C)fastening rear side.
3. Remove 2 screws(B) holding the PCB's.
4. Disconnect the CN811,CN614,CN613
5. Remove the changer mechanism ass'y(Fig.3).

CD Changer Mech. ass'y

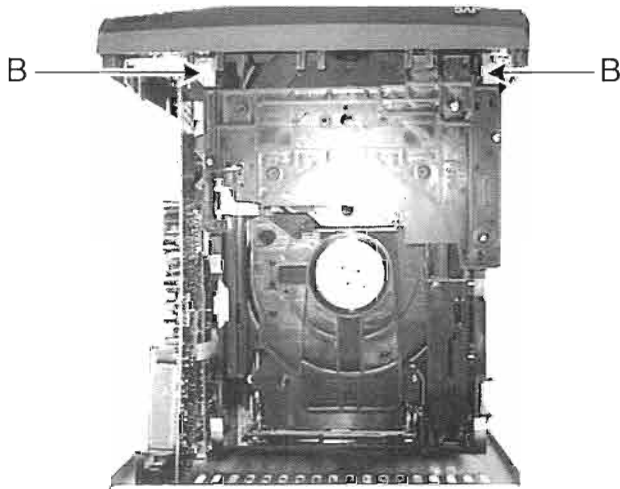

Fig.2

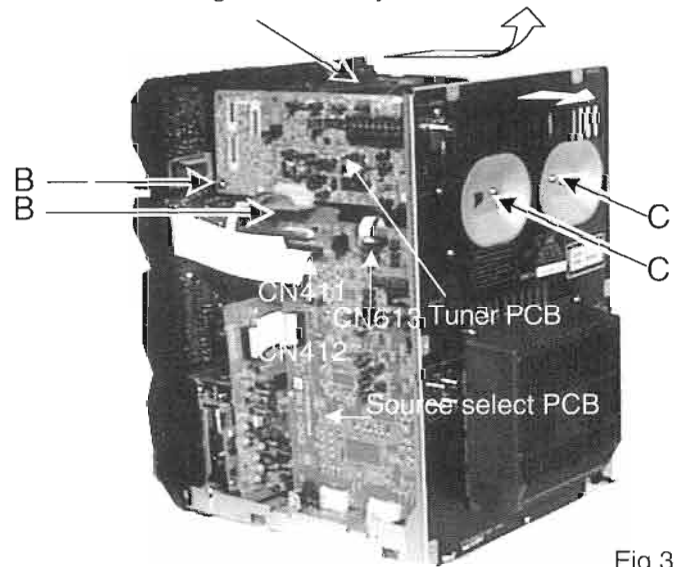

Fig.3

## (3) Removing the rear panel and Tuner PCB

1. Remove 9 screws(D)fastening rear side and remove the heat sink cover(Fig. 5).
2. Remove 3 screws(D)holding the heat sink.
3. Remove the rear panel and Tuner PCB.

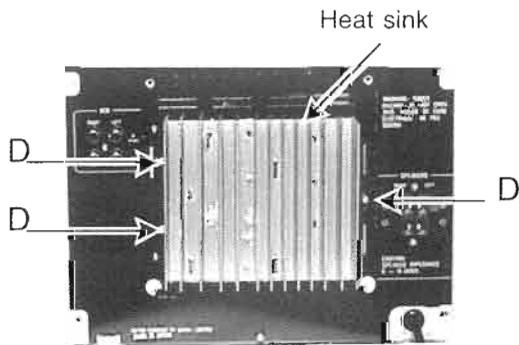

Fig.4

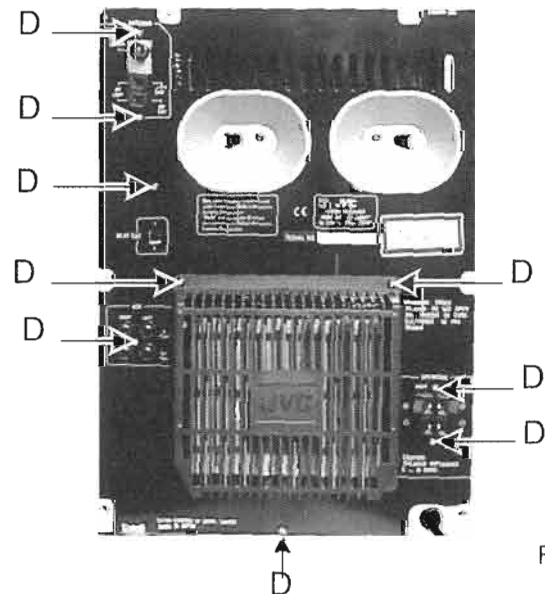

Fig.5

**(4) Removing the Front panel ass'y**

- 1.Remove the CDchanger mechanism.
- 2.Disconnect the CN411,CN412 and CN915,CN322.
- 3.Remove 2 screws(D)holding the Front panel ass'y.
- 4.Remove the 2 hooks fastening both sides of Front panel ass'y.

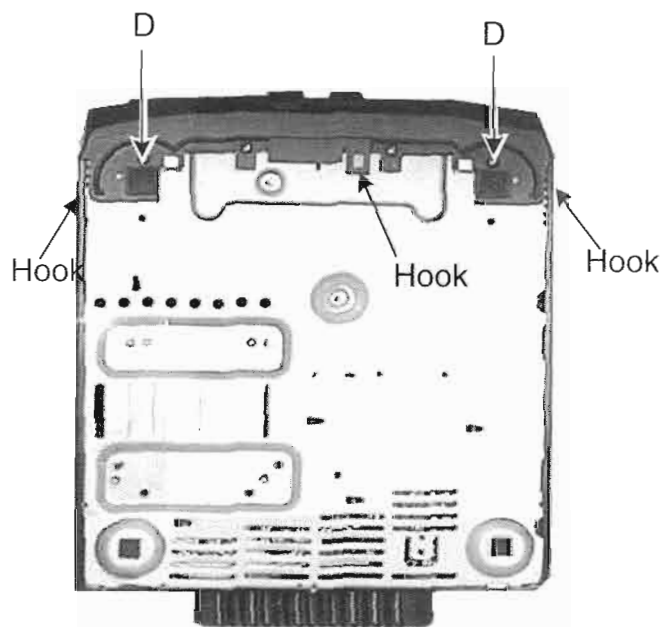

Fig.6

**(5) Removing the Cassette deck control PCB.**

- 1.Remove the Front panel Ass'y
- 2.Disconnect the CN331,CN332.
- 3.Remove 2 screws(D)holding the Cassette deck control PCB.

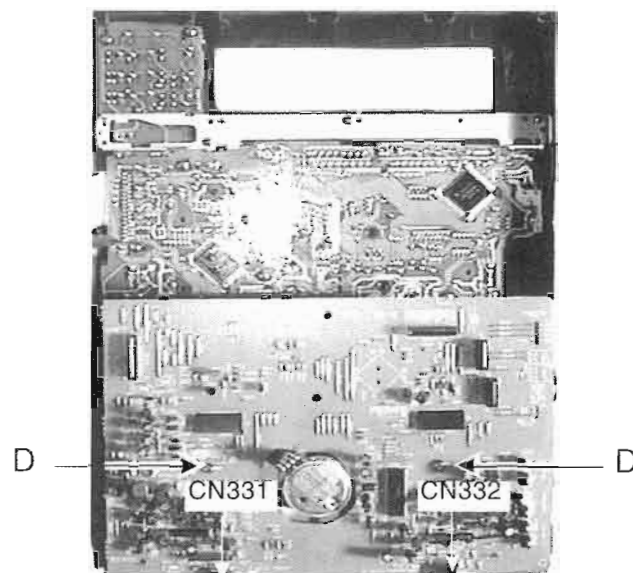

Fig.7

**(6) Removing the Cassette deck mech. ass'y**

- 1.Remove the Front panel Ass'y.
- 2.Remove the Cassette deck control PCB.
- 3.Remove 4 screws(E) and 4 screws(F) holding the Cassette mechanism ass'y.

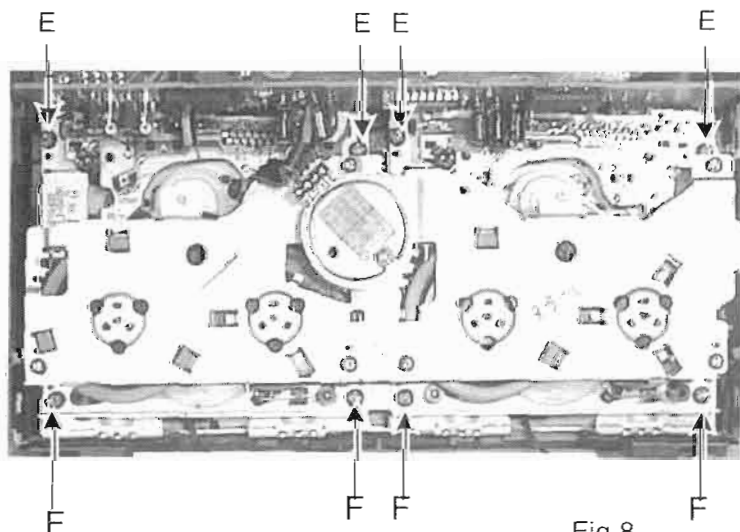

Fig.8

**(7) Removing the Amp /Speaker out/Source select PCB**

- 1.Remove the CD changer mech. and rear panel.
- 2.Disconnect the CN411,CN412,CN701, and Take the Source select PCB on the Power supply PCB.
- 3.Disconnect the CN915, and Take the Power amp and

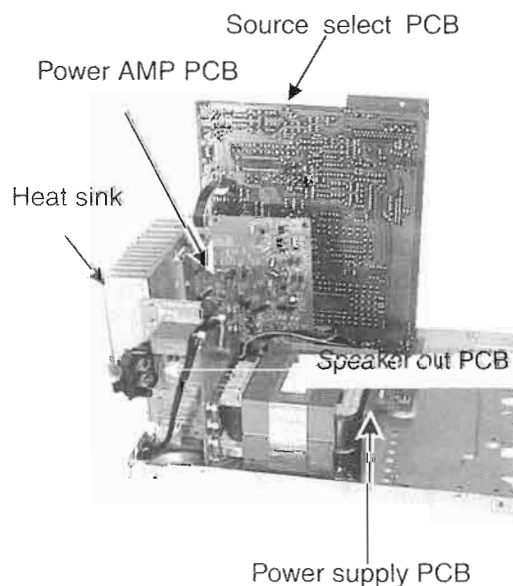

Fig.9

**(8) Removing the Power supply PCB**

- 1.Remove the CD changer mech. and rear panel, and take the Source select PCB,Amp PCB and Speaker out PCB.
- 2.Disconnect the CN009,CN111.
- 3.Remove the 3 screws(D) holding the Power supply PCB.
- 4.Remove the Power supply PCB.

**(9) Removing the Power Trans.**

- 1.Remove the CD chenger mech.
- 2.Disconnect the CN009,CN111.
- 3.Remove the 4 screws(G)holding the Power Trans.
- 4.Remove the Power Trans..

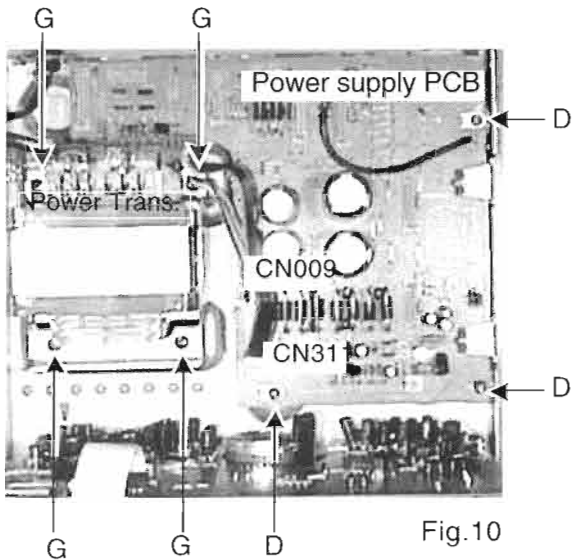

Fig.10

**(10) Removing the Front PCB**

- 1.Remove the Front panel Assy.
- 2.Remove the deck control PCB.
- 3.Remove the 4 screws(H)holding the Bracket.
- 4.Remove the 9 screws(H)holding the Front PCB.
- 5.Remove the 5 screws(H)holding the deck sw and main volume PCB.

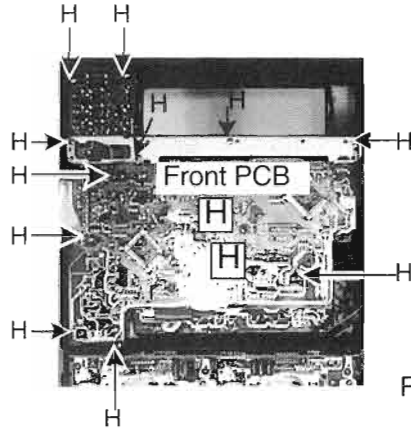

Fig.11

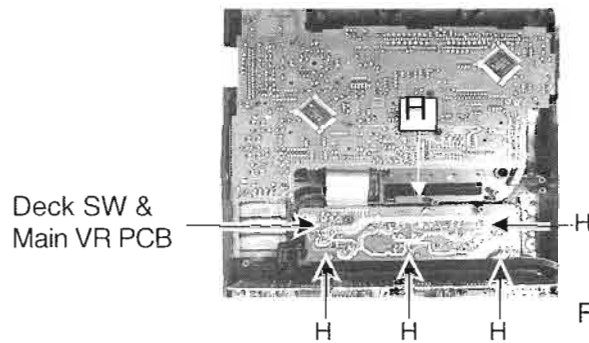

Fig.12

**(11) Removing the Power IC**

- 1.Remove the Amp PCB and Regulator PCB with the heatsink.
- 2.Remove 3 screws(G)holding the Amp PCB and Remove it.
- 3.Unsolder the Power IC terminals.
- 4.Remove the Power IC.

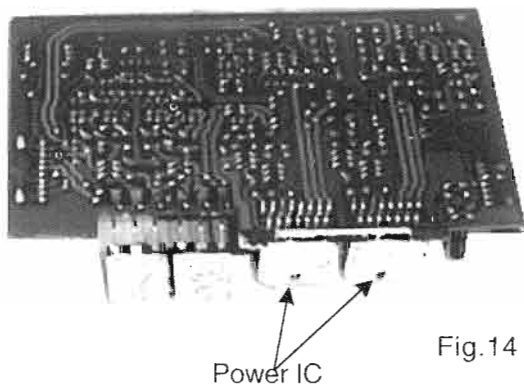

Fig.14

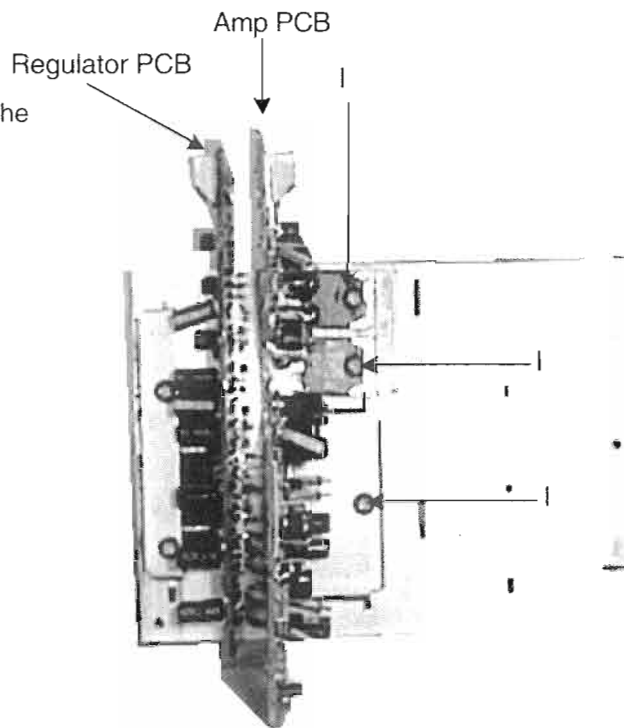
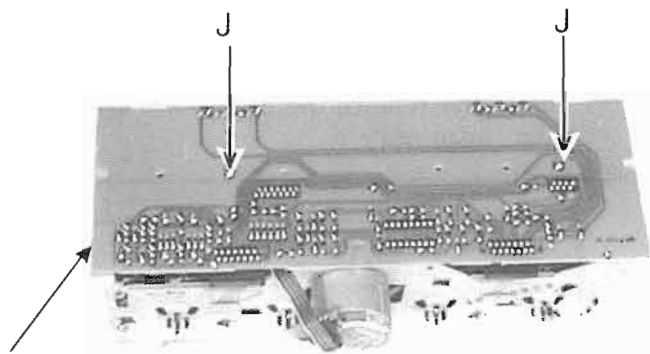

Fig.13



**(12) Removing the Capstan motor control PCB**

- 1.Remove the cassette mechanism ass'y.
- 2.Remove the 2 screws (J)holding the capstanmotor control PCB.
- 3.Remove the capstan motor control PCB.



Capstan motor control PCB

Fig.15

**(13) Removing the Cassette door**

- 1.Remove the cassette mechanism ass'y
- 2.Push the Cassette door holder both side.
- 3.Remove the cassette door.(See Fig.16)

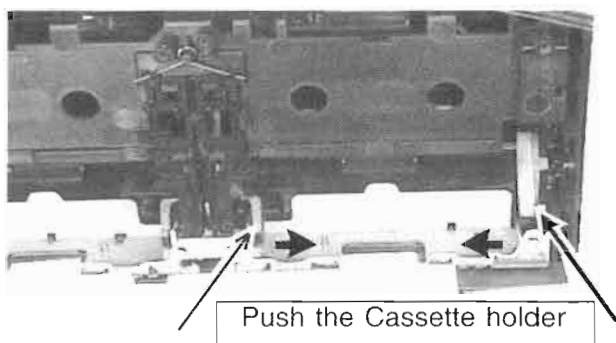

Fig.16

**(14) Fix the Cassette Holder spring**

Fix holder spring before fix guide . and cassette mech.(See Fig.17)

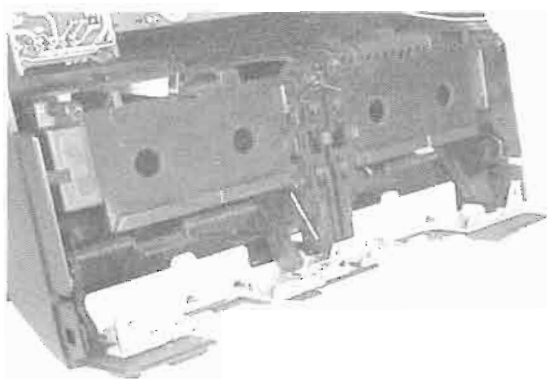
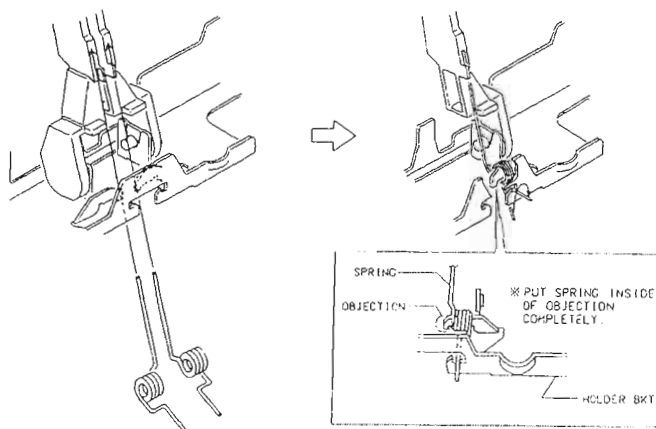

Fig.17



## Cassette Mech. Ass'y removal

(15) Head assembly removal

1. Remove the Cassette mech. ass'y.
2. Remove the flexible wire from the cassette deck and remove the 3 screws  $\text{\textcircled{K}}$  holding the head ass'y.

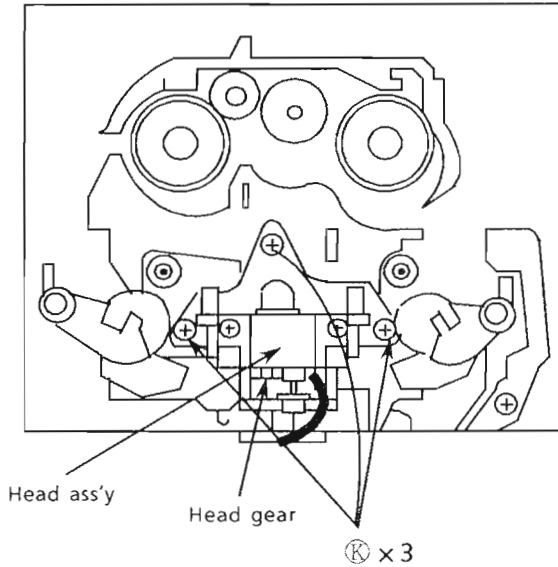

Fig. 18 Cassette mechanism top view

(17) Pinch roller (FWD/REV) removal

1. Remove the cassette mech. assembly.
2. Remove the hook holding the pinch roller.
3. Remove the pinch roller ass'y.

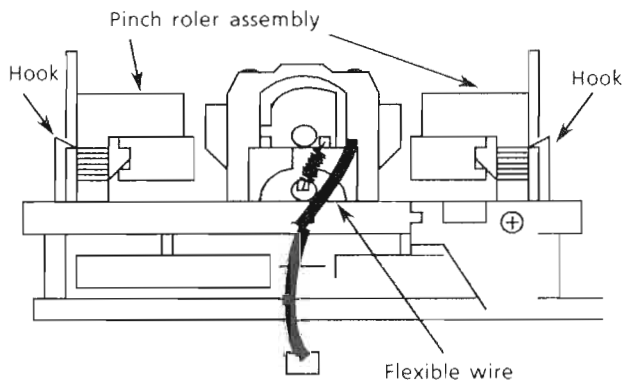

Fig. 20 Cassette mechanism bottom view

(16) Head assembly

1. The direction of the head is changed with the direction lever. When servicing, install the direction lever according to the direction of the head assembly.

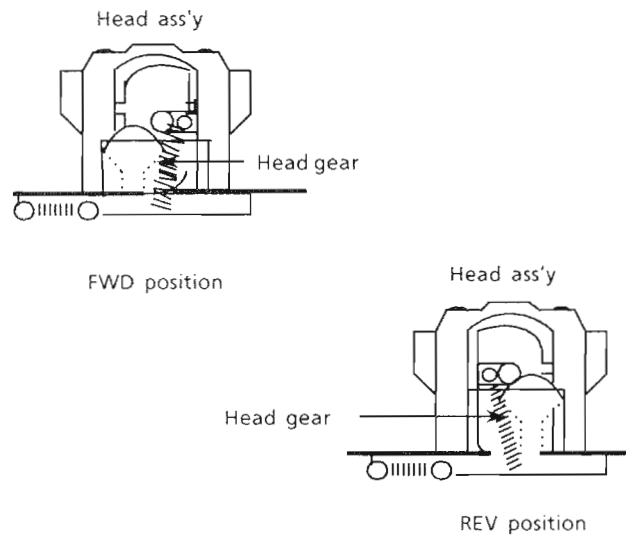

Fig. 19-A Head ass'y side view

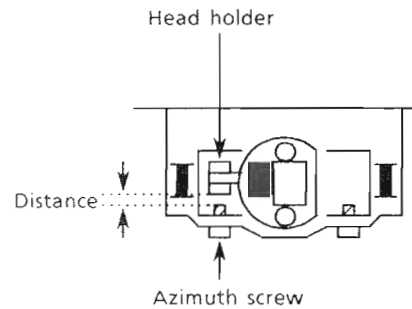

Fig. 19-B A distance of between head older and azimuth screw

(18) Capstan motor removal.

1. Remove the cassette mechanism.
2. Remove the cassette deck control PCB.
3. Remove the 6 screws (Ⓛ) holding the bracket.
4. Remove the hooks (■) of the bracket.
5. Put the cutting on the flywheel A together the bracket's pall as shown in fig. 22(Flywheel A) and check that the flywheel B is removed from the bracket's pall (fig. 22-Flywheel B).
6. Remove the capstan motor with the bracket.
7. Unsolder the broken flat wire of the capstan motor.
8. Remove the 2 screws fixing the motor and the bracket.

\* To remove the bracket, it is easier to remove mech. "B" first.  
 Vice versa, assembling mech. "A" is easier for reassembly.

8.7 ± 0.05mm

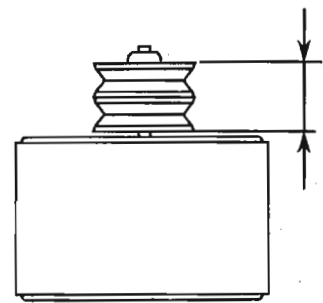

Fig. 21 Capstan motor pulley installation

(19) Flywheel removal

1. Remove the cassette mechanism assembly.
2. Remove the cassette amp PCB.
3. Remove the 6 screws (Ⓛ) and the bracket.
4. Remove the 4 hooks of the bracket.
5. Remove the bracket.
6. Remove the flywheels.

\*The oil on the capstan must be wiped out after reassembling.

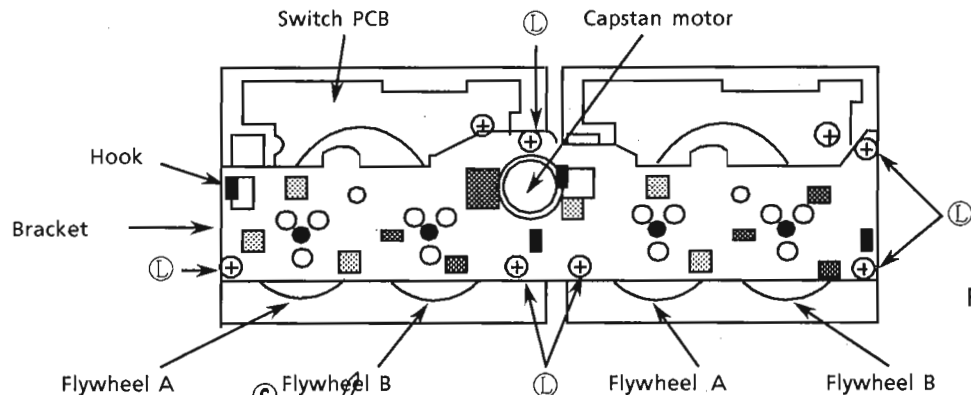

Fig. 22-A

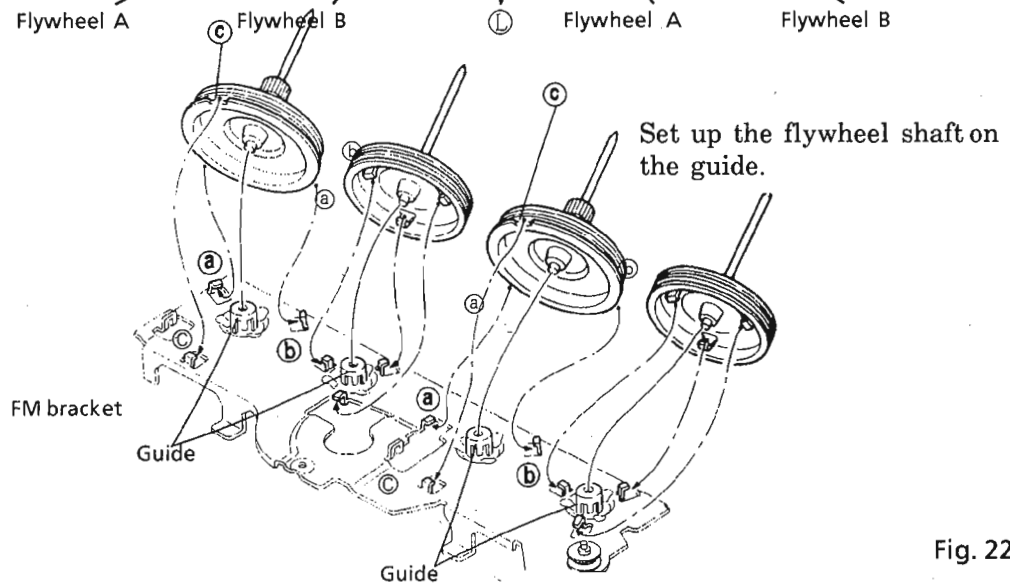

Fig. 22-B

(20) How to install the belts

1. Install the flywheels and belts as shown in the figure below. ( Fig. 23 )

When putting the belts, put the long belt first.

2. Install the main reels to put the belts on the flywheels.

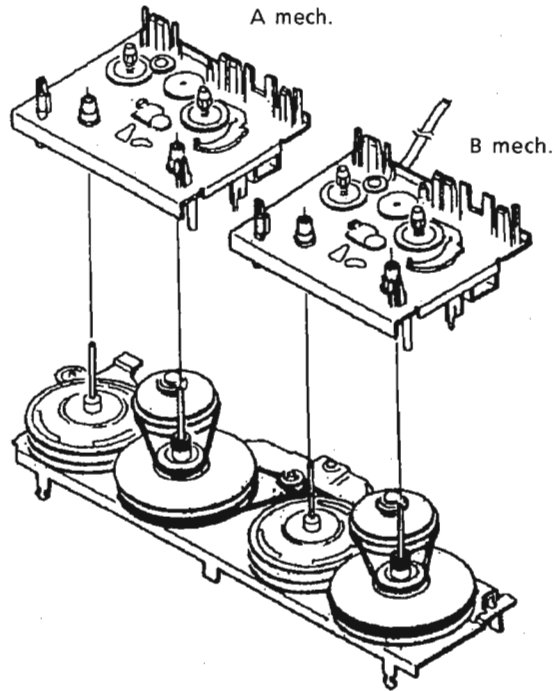
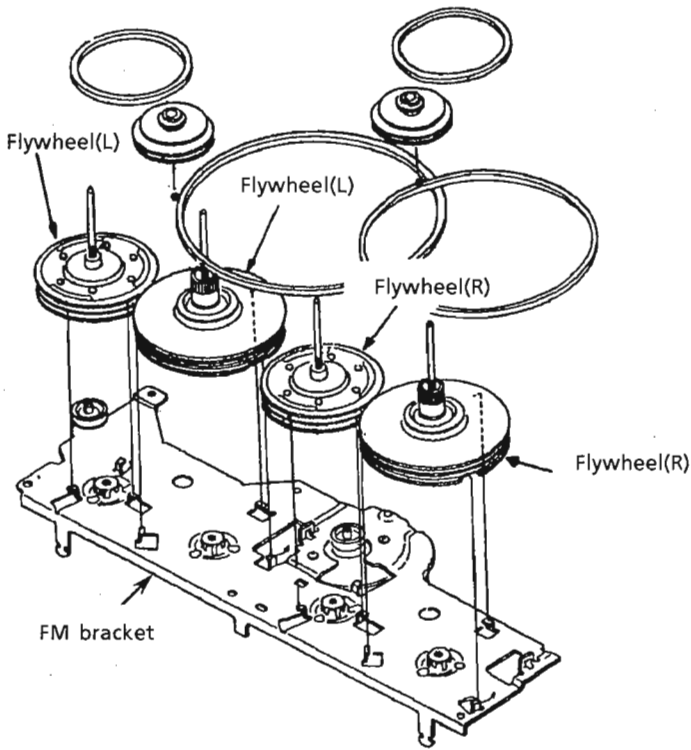
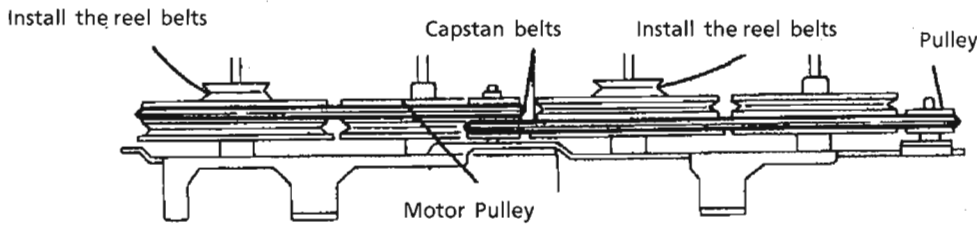

Fig. 23-A Install the Bracket and flywheels

Fig. 23-C Install the cassette mech.



REEL BELTS → After hooking reel belts, no twist.

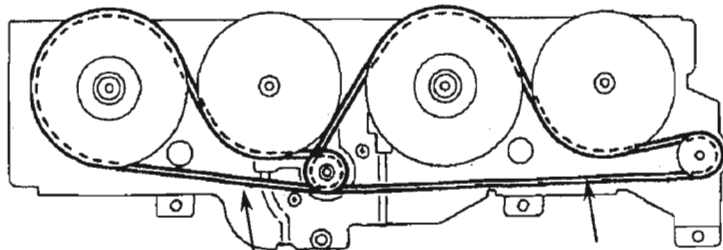
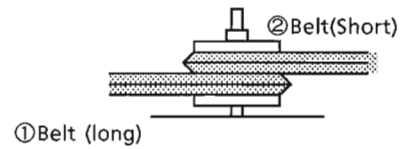

Fig. 23-B Install the Belts

②Belt(Short)

①Belt (long)

**(21) Switch PCB removal**

1. Remove the flywheel.
2. Remove the 1 screw  $\text{\textcircled{M}}$ .
3. Unsolder the broken solenoid.
4. Release the 4 hooks holding the Switch PCB.
5. Remove it.

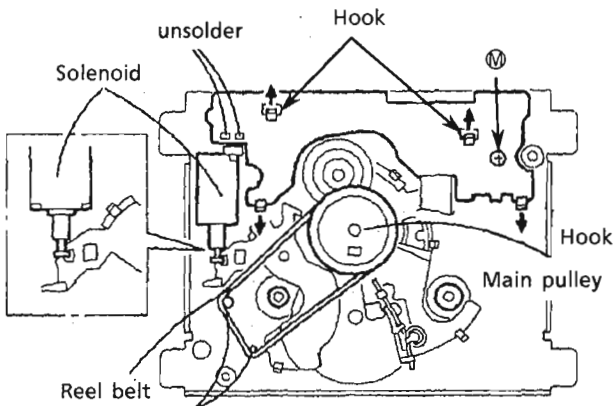

When attach the FM bracket,  
Install the reel belt on the stud  
(See fig. 23)

Fig. 24

**(22) Control cam removal**

1. Remove the FM bracket and flywheel.
2. Pull out the main pulley.
3. Remove the trigger arm.  
While opening the two tabs  $\text{\textcircled{a}}$  under the trigger arm, pull out the trigger arm from the shaft.
4. Pull out the elevator ring.
5. Remove the FWD/REV arm assembly.  
a. Remove the FWD/REV arm spring.  
b. While opening the four FWD/REV arm retaining tabs  $\text{\textcircled{b}}$  outwards, pull out the FWD/REV arm.
6. Pull out the control cam.  
While pulling the shaft stopper section of the control cam in the central direction, pull out the control cam.

**When attaching the control cam**

While pressing the FWD/REV arm in the direction of the sorrow, pull the head the front.

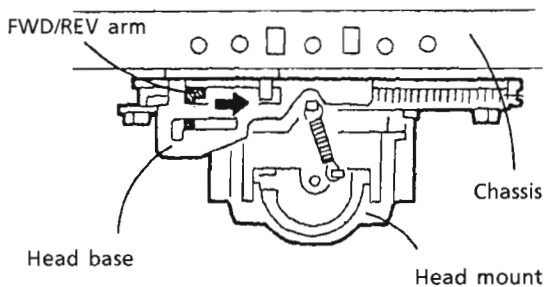
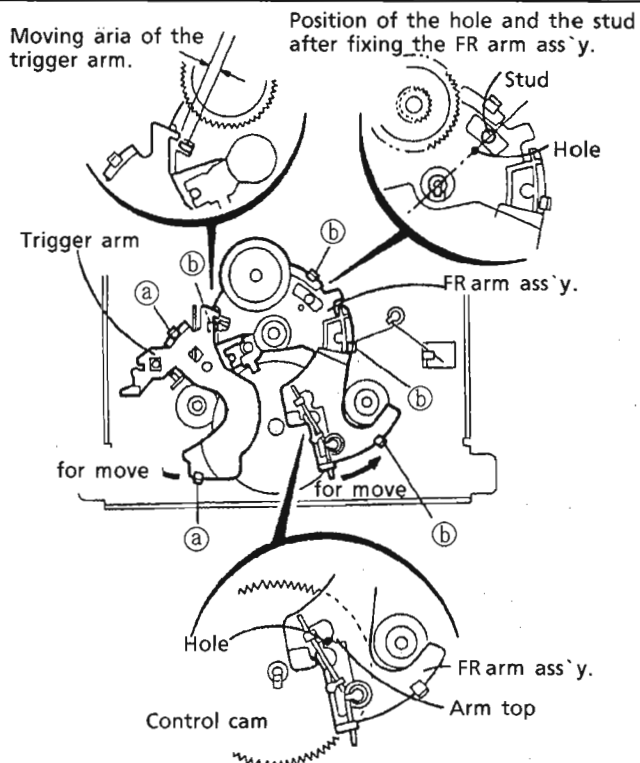

Fig. 25-c



Position of the hole of cam and top of the arm after fixing the FR arm ass'y.

Fig. 25-a

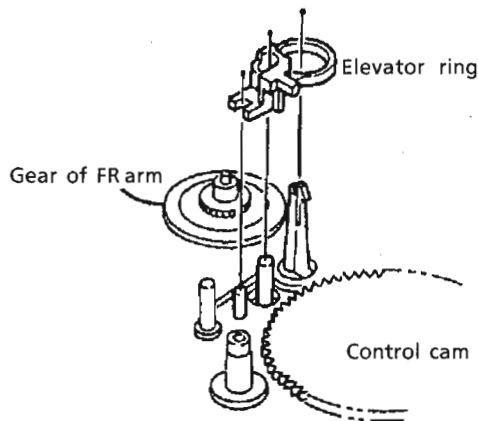

Fig. 25-b

After performing the procedure shown above, the studs under the control cam move as shown.

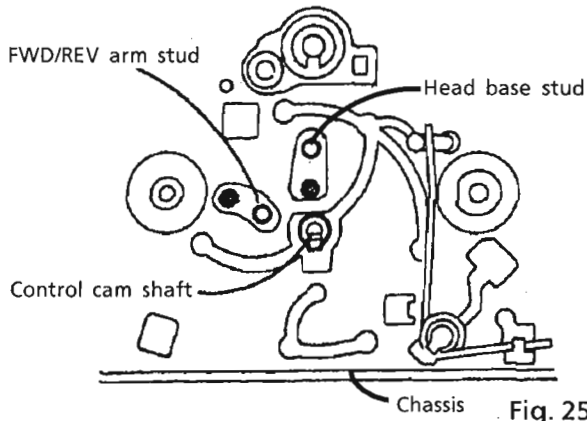
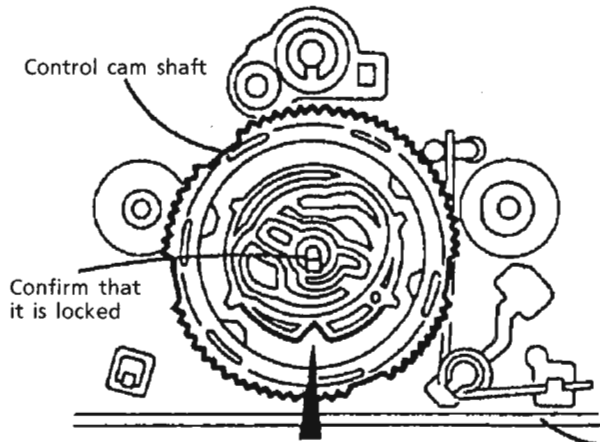

Fig. 25-d

## (23) How to assemble

1. Move the FWD/REV arm in the direction of the arrow .
2. In step 1 , pull the head base forward .
3. In step 2 , after inserting the cam into the shaft , move the head base and FWD/REV arm slightly until the cam is fully inserted and it clicks to inform when it has been locked .
4. Rotate the cam counterclockwise to check if the cam rotates smoothly and the spring clicks according to the forward/backward movement of the head base .
5. After checking the rotation of the cam , rotate the cam until the notch section comes to the right so that the FWD/REV arm assembly can be attached .
6. Attach the FWD/REV arm assembly while observing the positioning of:
  - the hole and stud
  - the cam hole and arm edge
 shown in the figure 25-a .  
 After attachment , move the FWD/REV arm in the direction of the arrow to check if it moves back to the original position .
7. Attach the elevator ring .
8. Attach the trigger arm .  
 After attachment , move the trigger arm in the direction of the arrow to check if it moves back to the original position .

Working confirmation:  
 If the control cam rotates counterclockwise ,the assembly was successful: if it does not rotates . It must be reassembled .



Fit the control cam its notch located as shown .  
 (Engage with the gear of the control cam while moving the FWD/REV arm and head base slightly .)

Fig. 26-a

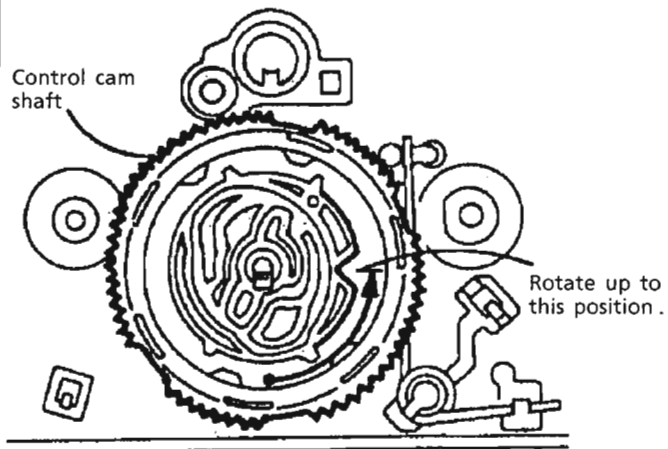

Attach the FWD/REV arm with the control cam rotated up to the position shown .

Fig. 26-b

## CD Changer mech. Ass'y removal

### (24) CD Tray assembly removal

1. Disassemble the changer mech..
2. Remove the screw ③ holding the stopper bracket.(See Fig.27) ---- (U.S.A only)
3. Remove the rod from both ends' hooks which are secured on T.Bracket ④ and clamper base ⑤. [See Fig. 27]
4. Remove 3 screws ① securing T.Bracket.(See Fig. 29.)
5. Remove a screw ⑥ securing center of the clamper ass'y.(See Fig. 28)
6. Remove the clamper ass'y from ★ screw fixing side.
7. Remove a screw ⑦ which secures the return spring and lock levers from the chassis ass'y.(See Fig. 30.)
8. Remove 2 palls ⑧ which slightly secure the return spring to remove it.
9. Remove 3 lock levers.
10. Check that the lifter unit stopper is inserted into hole ⑨ located on CD tray ass'y. (See Fig. 31.)
11. Check that the driver unit elevator is seen from a hole (marked ⑩) on left side of the CD changer mech..(See Fig. 32 and 33.)  
[NOTE] Set the elevator in correct position (Fig. 33) by rotating the pulley gear with finger if it is not positioned correctly (Fig. 34.).
12. Rotate the motor pulley clockwise with finger until the lifter unit's stopper is lowered from ⑨ hole located on the CD tray ass'y. (See Fig. 34.)
13. And, pull all 3 CD tray assemblies forward until they stop. (See Fig. 32.)
14. Press 2 pawls (f, f) located rear side of the CD tray ass'y according to an arrow ⑪ to remove the CD tray ass'y. (See Fig. 35.)  
At first, removing the lowest tray is easier.

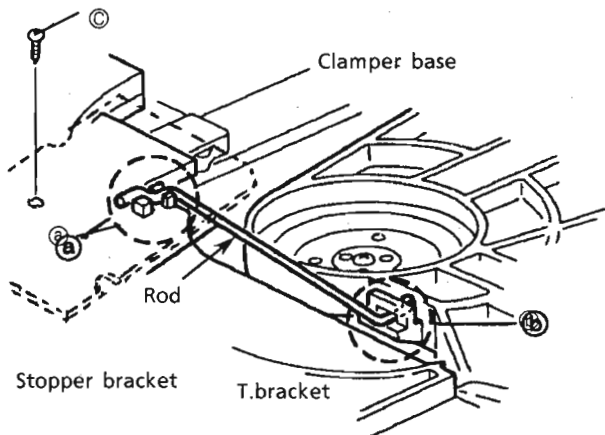

Fig. 27

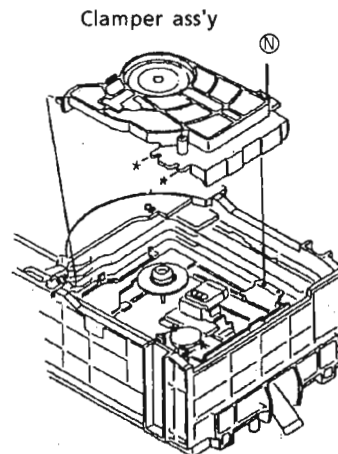

Fig.28

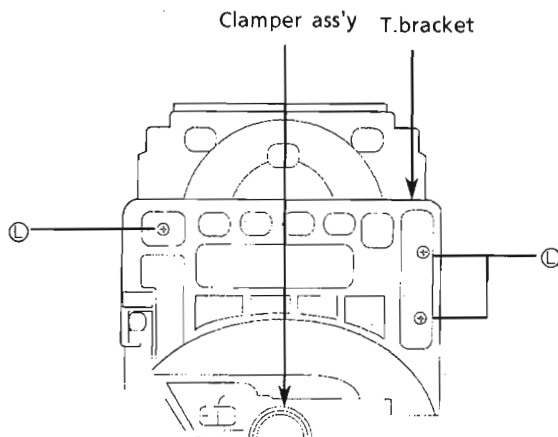

Fig.29

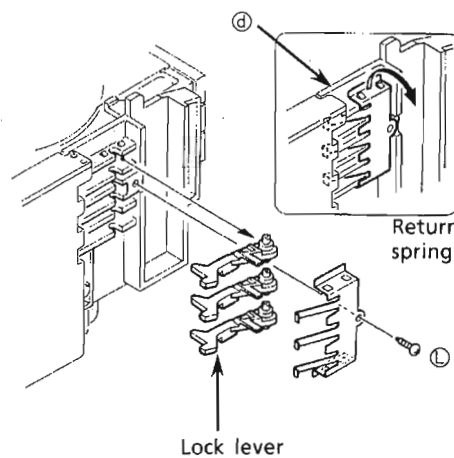

Fig.30

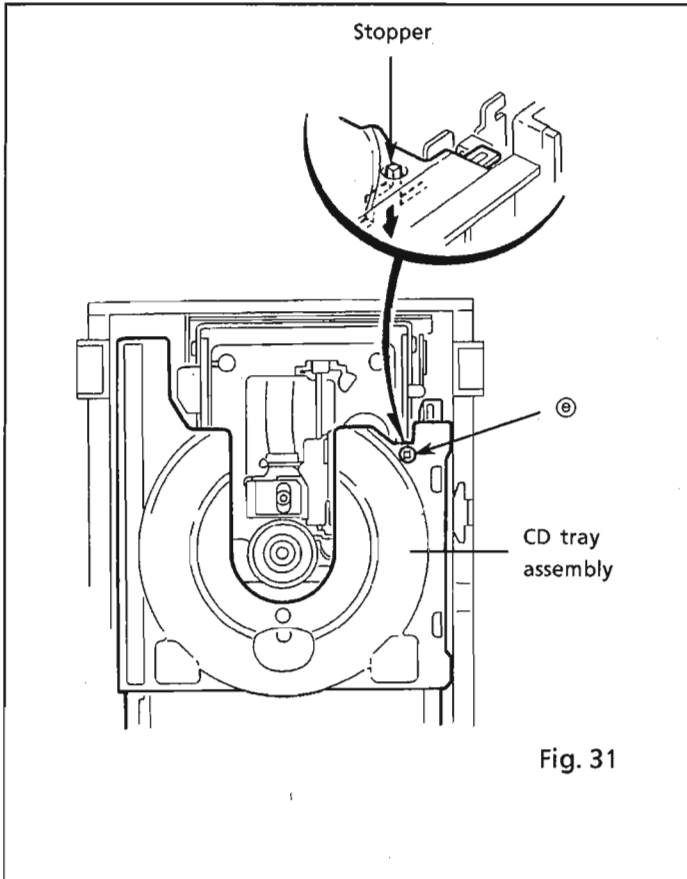

Fig. 31

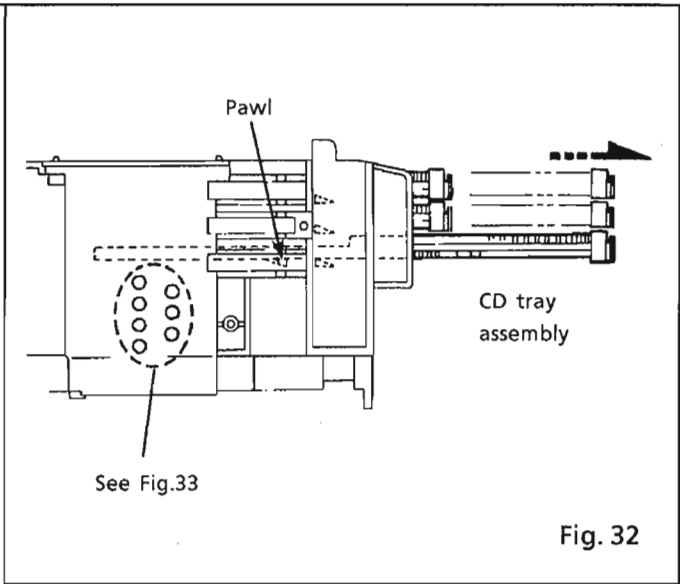

Fig. 32

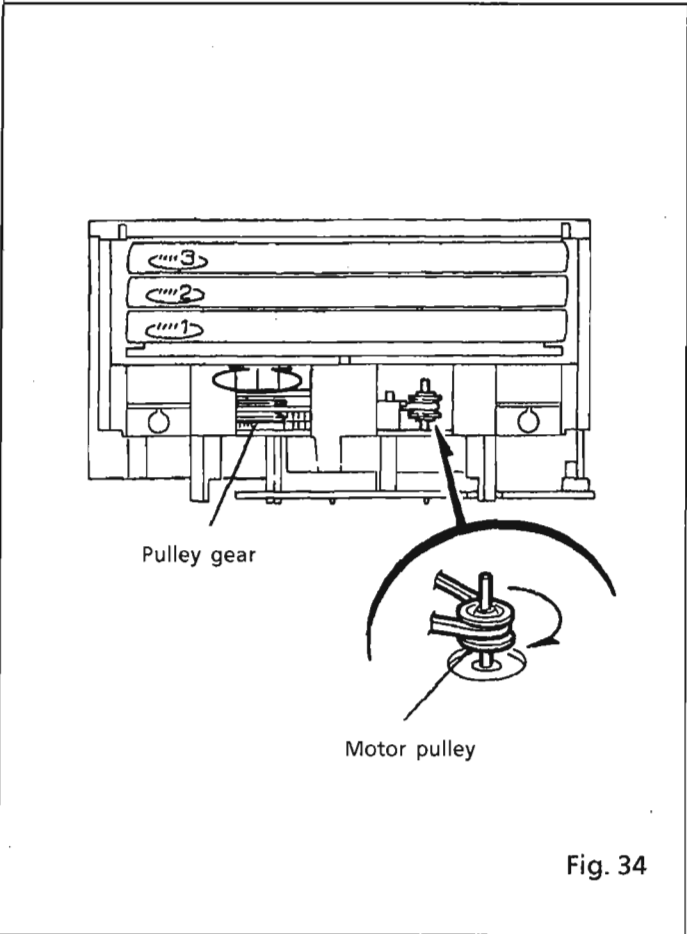

Fig. 34

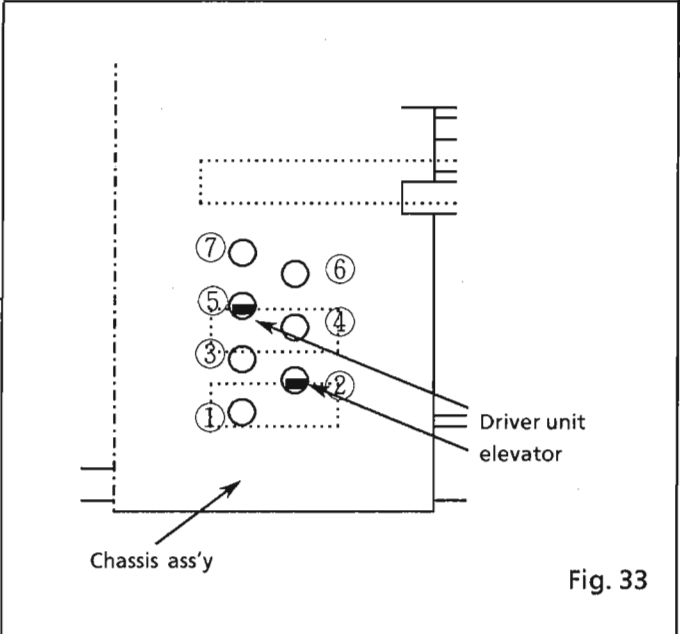

Fig. 33

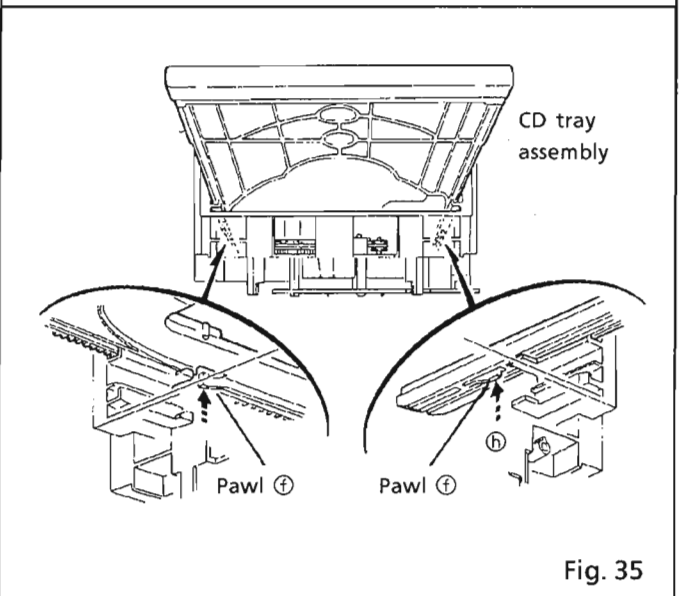

Fig. 35



**(25) CD mechanism removal**

1. Remove the CD tray ass'y.
2. Rotate the Cam R1, R2 ass'y counterclockwise so that CD mech. ass'y's shaft ⑥ is positioned as shown in Fig. 36.
3. Remove 4 screws ① securing CD mech. ass'y. (See Fig. 36.)

**\*How to replace pick-up unit**

1. If CD mech. is removed without disassembling CD mech. ass'y, rotate the Cam R1, R2 ass'y clockwise to set the CD mech. ass'y's shaft(L) as shown in Fig. 37.
2. Lift the CD mech. ass'y toward the direction ① to remove it from the lifter unit. (See Fig. 38.)

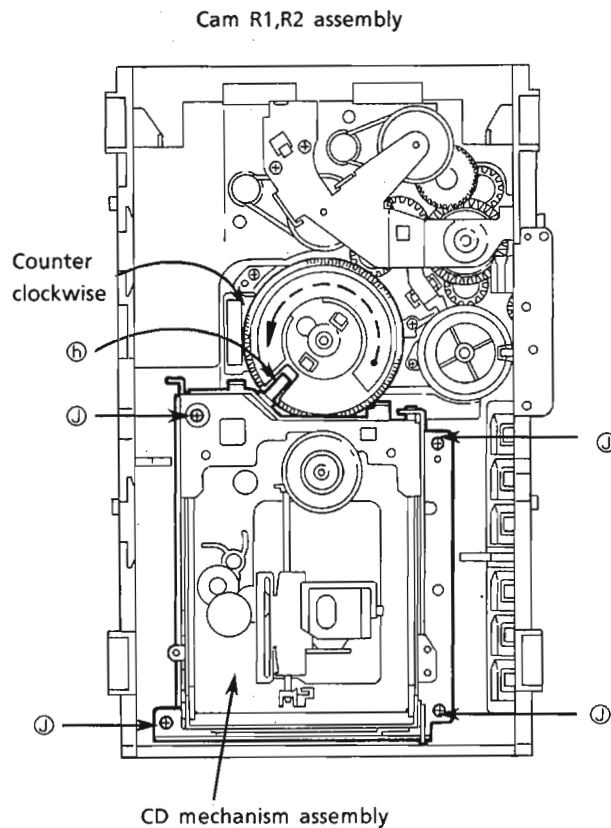

Fig. 36

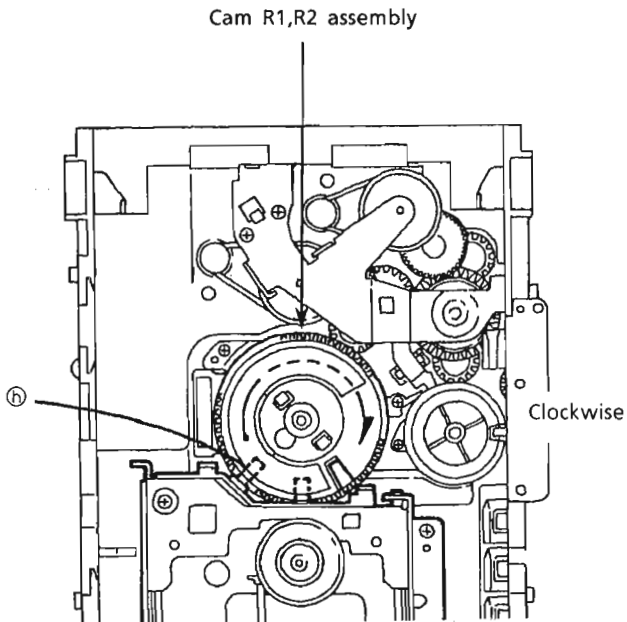

Fig. 37

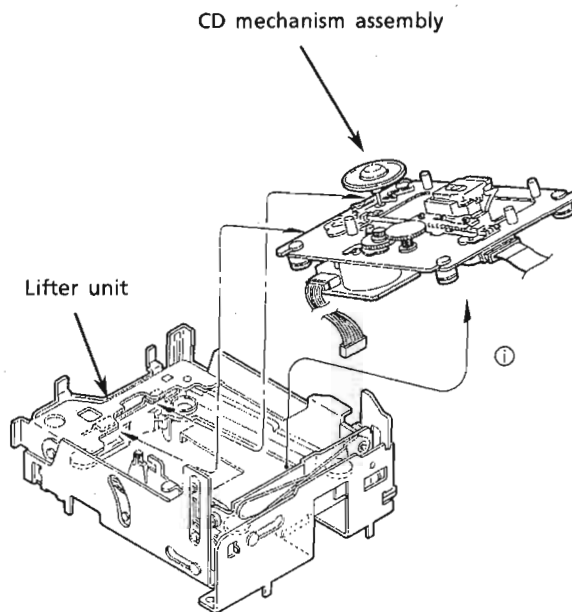

Fig. 38

(26) Actuator motor board removal

1. Unsolder 4 soldered point ① for both motors. (See Fig. 39.)
2. Remove a screw ③ securing the CD servo board. (See Fig. 39.)
3. Press the hook and release it to remove the CD servo board.
4. Remove 2 screws ① securing the actuator motor board. (See Fig. 39.)
5. Remove 2 screws ① securing the tray select switch board. (See Fig. 40.)

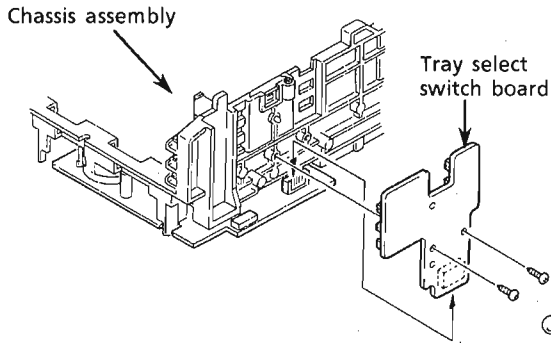

Fig. 40

(27) Cam unit removal

1. Disassemble CD mech. ass'y.
2. Rotate the Cam gear L so that the drive unit's pole ④ is positioned as shown in Fig. 41.
3. Remove the drive unit and cylinder gear. (See Fig.42.)
4. Rotate the Cam gear L so that the select gear's ① is positioned as shown in Fig.43.
5. Remove 4 screws ① securing the cam unit which includes the cam gear L and Cam R1, R2 ass'y. (See Fig 43.)

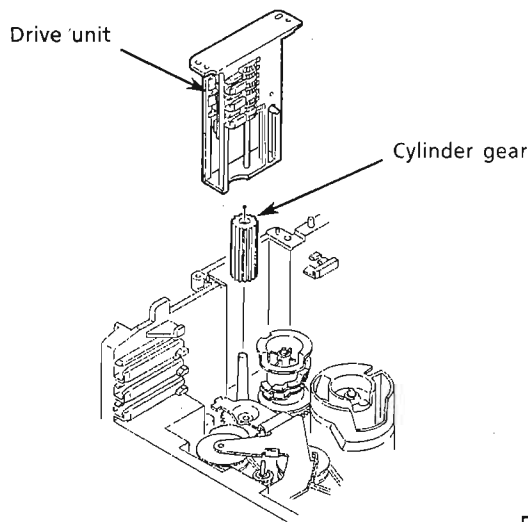

Fig. 42

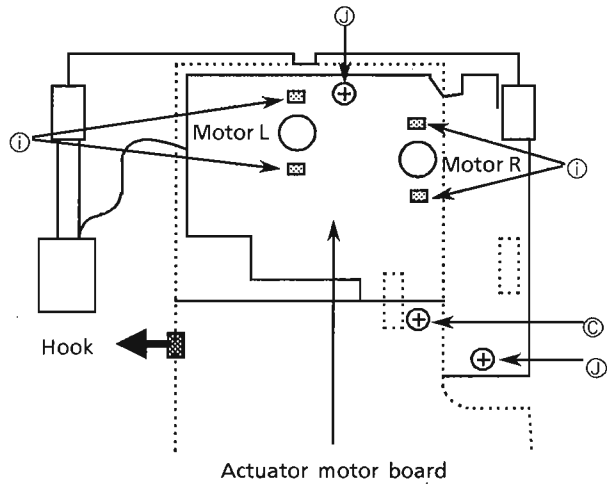

Fig. 39

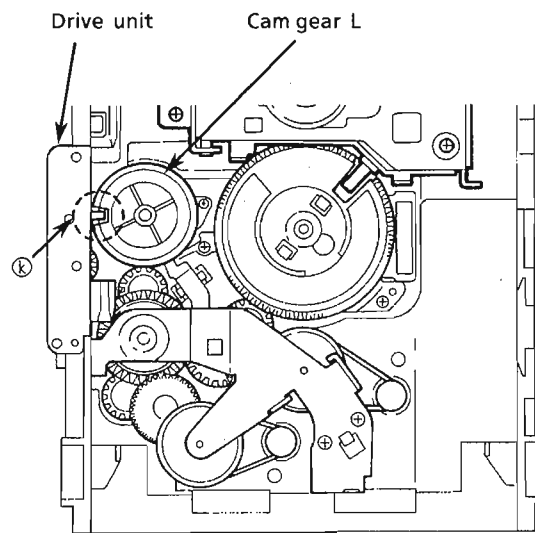

Fig. 41

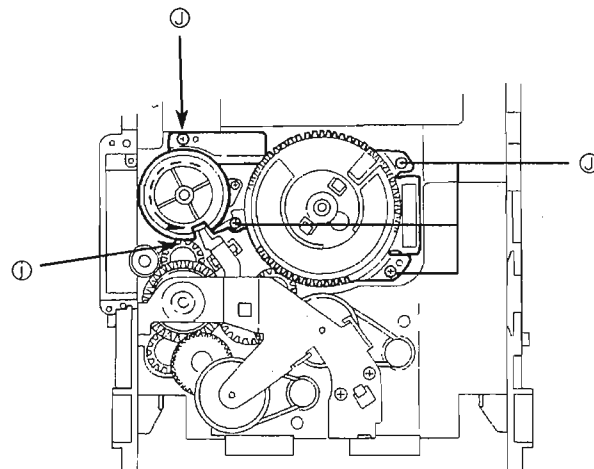

Fig. 43

(28) Removal for actuator motor and belt

1. Remove 2 screws ① securing the gear bracket.  
(See Fig. 44.)
2. Press the pawl ② securing the gear bracket to the arrow in the figure to remove the gear bracket. (See Fig. 44.)
3. Remove the gear bracket from the chassis ass'y's ③ securing top of the gear bracket. (See Fig. 45.)
4. Remove each belts from the both actuator motor pulleys and the pulley gears. (See Fig.44.)
5. Reverse the chassis ass'y and widen 4 poles ④ which secure both actuator motors to its arrows to remove the actuator motors. (See Fig.46.)

[NOTE] The pulley gears and other gears which consist the gear unit may drop separately if the chassis ass'y is reversed without gear bracket and belt. See Fig. 47 to assemble them again.

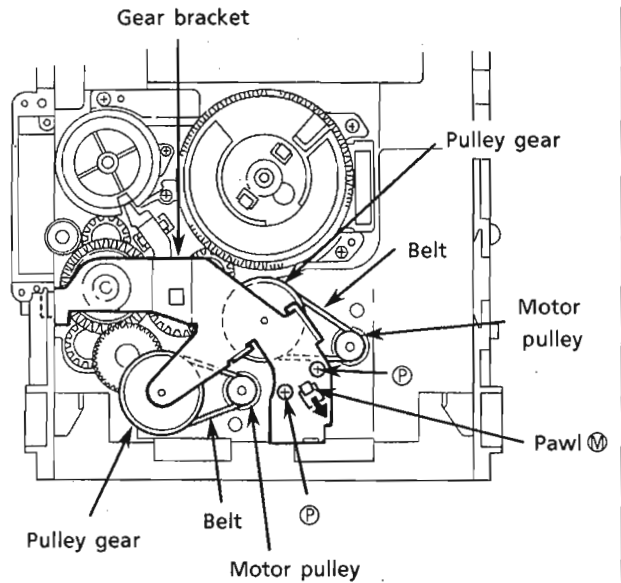

Fig. 44

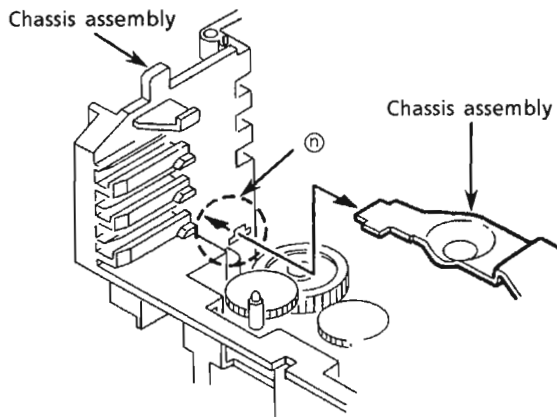

Fig. 45

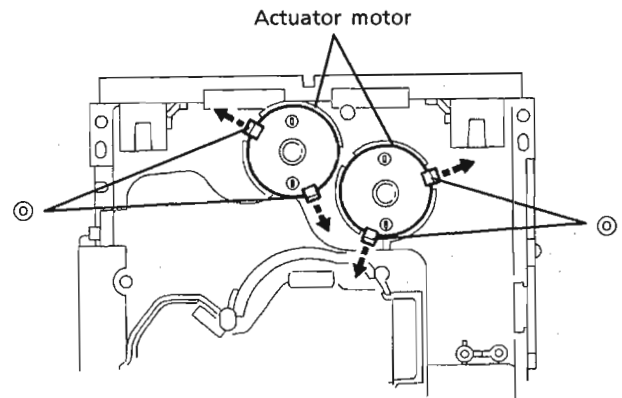

Fig. 46

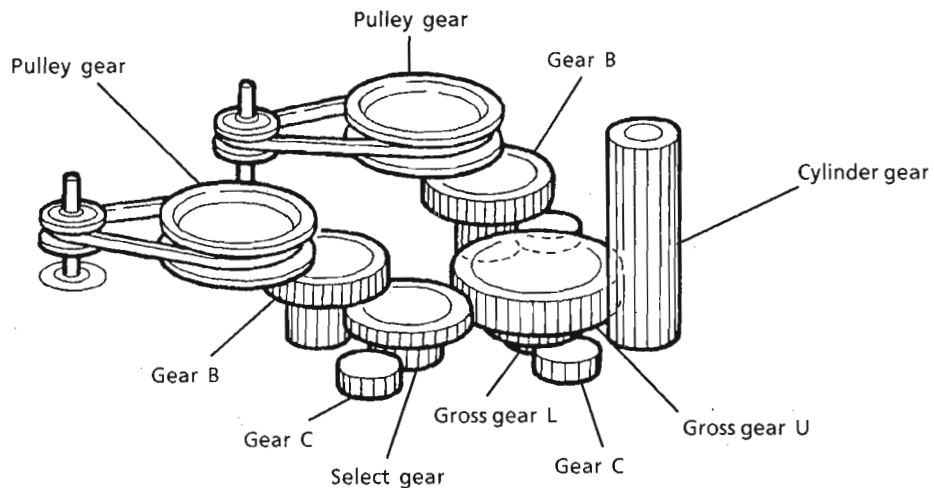

Fig. 47

(29) Removal of cam R1, R2 ass'y and cam gear L

1. Remove the slit washer securing Cam R1, R2 ass'y.  
(See Fig. 48.)
2. Remove 2 poles ⑤ securing Cam R1 to remove Cam R2 from Cam R1.
3. Remove the slit washer securing Cam gear L.
4. Remove Cam gear L from the C.G. base ass'y.

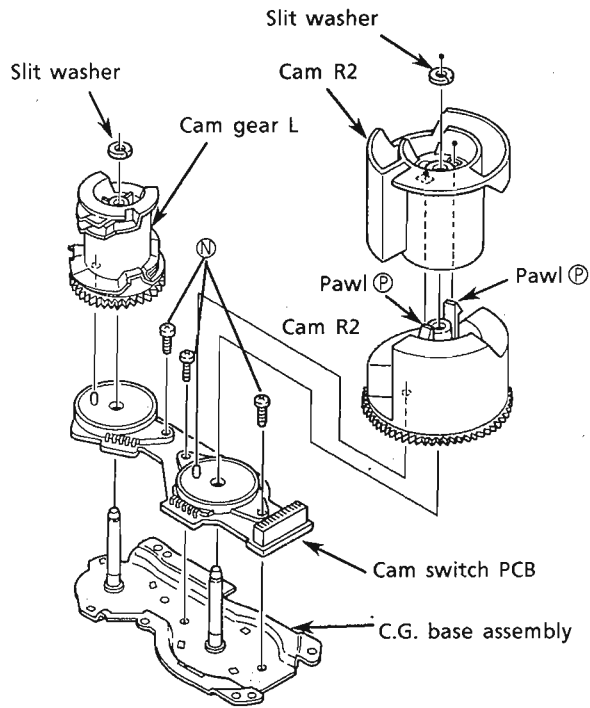

Fig. 48

(30) Removal of C.G. base ass'y

Remove 3 screws ⑥ securing the C.G. base ass'y. (See Fig. 48 and 49.)

[NOTE] Set the drive unit's pawl ⑧ so that it is positioned as shown in Fig. 49.  
Confirm that the cam gear L engages with the gear unit by rotating the cam gear L.

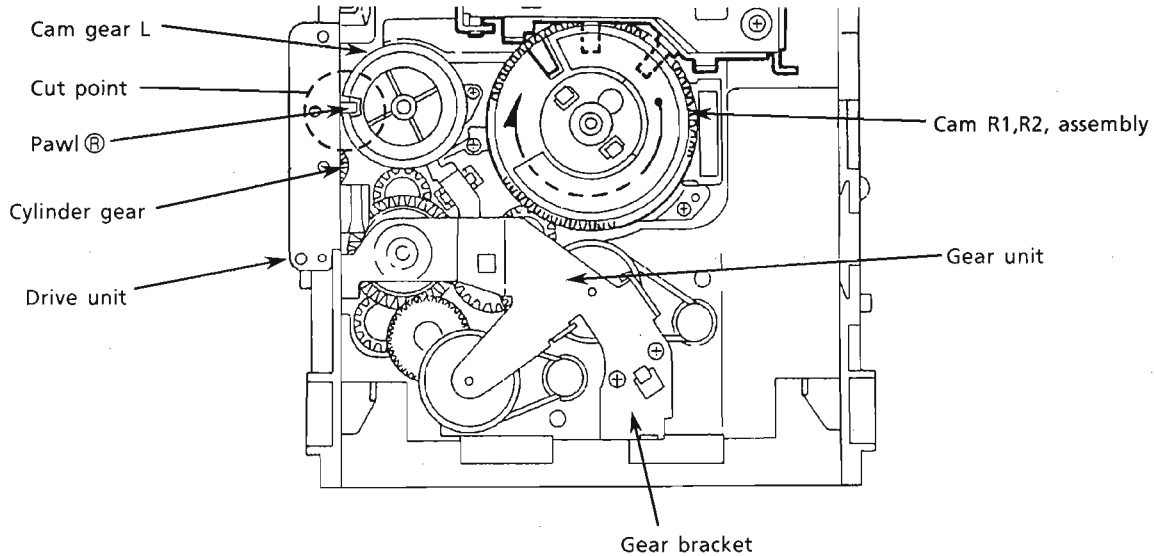

Fig. 49

- (31) Removing the Pickup
1. Remove the CD mech. assembly.
  2. Release the shaft to remove the pickup.

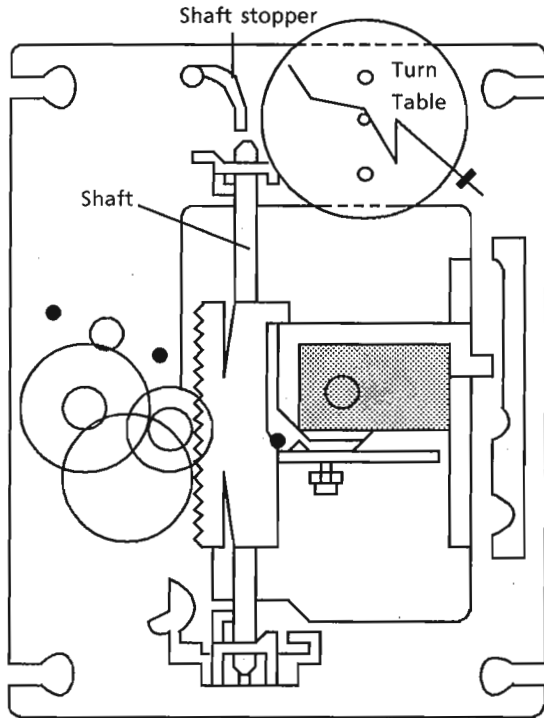

Fig. 50

- (32) Spindle motor installation
1. Tighten the 2 screws to the same torque.
  2. Fasten the spindle and feed motor P.C. board with the screw and solder.
  3. Install the turntable. When installing, press straight down at the center of the turntable until the distance from the surface of the mech. base to the turntable is exactly  $19.4 \pm 0.1\text{mm}$ .

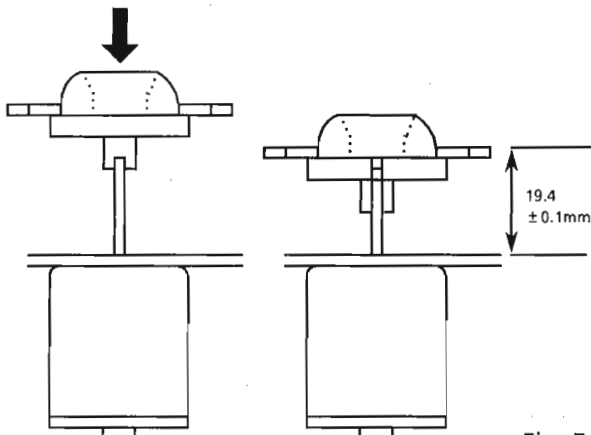

Fig. 51

- (33) Removing the Spindle motor
1. Remove the CD mech. assembly.
  2. Remove the turntable, and remove the 2 screws ⊗ retaining the spindle motor.
  3. Remove the screw retaining the spindle and feed motor circuit board and unsolder it.

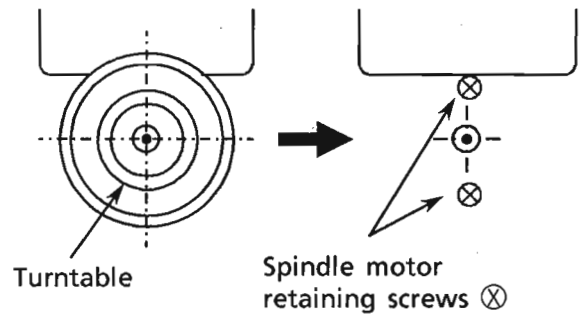

Fig. 52

- (34) After inserting the turntable, bond the motor shaft and turntable together (at the section marked by an arrow in fig 53 on the left below).

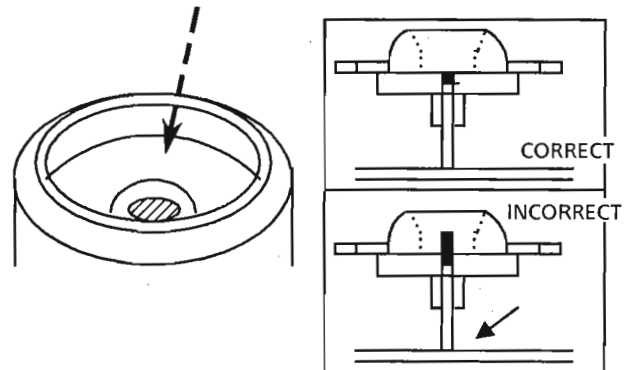

Fig. 53

- (35) Use "LOKTTITE" #460 bonding agent, and apply as little as possible.
- Take care not to allow any excess bonding agent to get onto the turntable.
- Be extremely careful not to allow bonding agent to adhere to the motor bearing (the section marked by an allow in fig. 53 on the right).

## ***Connected an extension cord***

- 1.Remove the CD changer mechanism ass'y.
- 2.Disconnect the 7pin wire from the CN613(Source selector & SEA P.C.B)and disconnect the 7pin wire.
- 3.Connected the extension cord CN603 to CN613.

Connection cord  
(Part No.EWR107E-50TT)

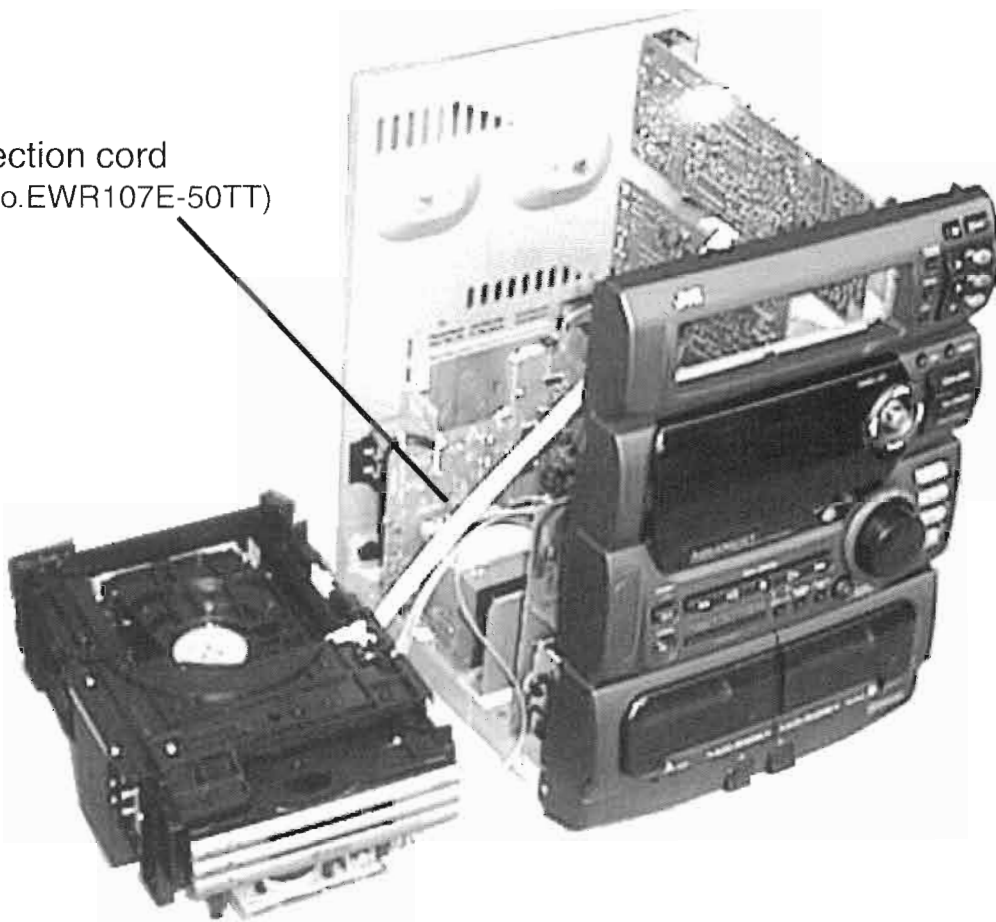

Changer mechanism Ass'y

# Adjustment procedures

## ■ Tuner section

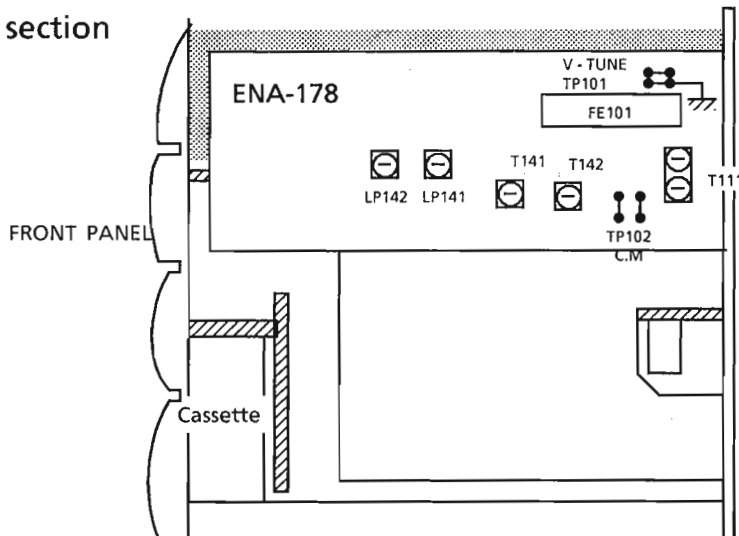
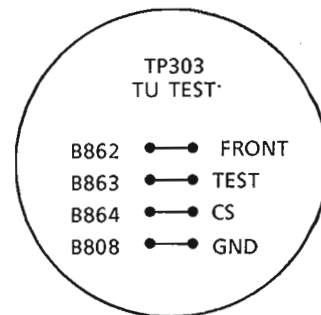

Fig.1



ENC-136-2  
(Deck control PCB)

### Clock Adjustment

1. After connecting B863 and B864 with some wire as shown in the figure below, connect the AC power cord into an AC outlet.
2. Confirm that the display is off and remove the wire.
3. Connect a frequency counter to TP303 B262 and B808.
4. Confirm the frequency  $50000 \pm 0.29\text{Hz}$ .

### (1) Tuning voltage

Confirm the voltages at TP101 is within the standard values shown in the table below. If the voltages are not satisfied, replace T111 for MW 5or FE101 for FM.

FM Tuning voltage (Unit : V)

Area	Frequency	
	87.5MHz	108MHz
USA,Canada	$1.6 \pm 1.0 (V)$	$8.0 \pm 2.0 (V)$

AM Tuning voltage (Unit : V)

Area	Frequency (MW)						
	522KHz	530KHz	531KHz	1600KHz	1602KHz	1629KHz	1710KHz
USA,Canada	—	>0.8	—	—	<7.9	—	<8.8

### (2) FM center meter

Receive a broadcast which understanding the frequency by using the function of 'MANUAL SEARCH'. Adjust T141 (detector coil) so that the voltage at TP102 becomes  $0 \pm 1.5\text{mV}$ .

■ Deck Adjust point

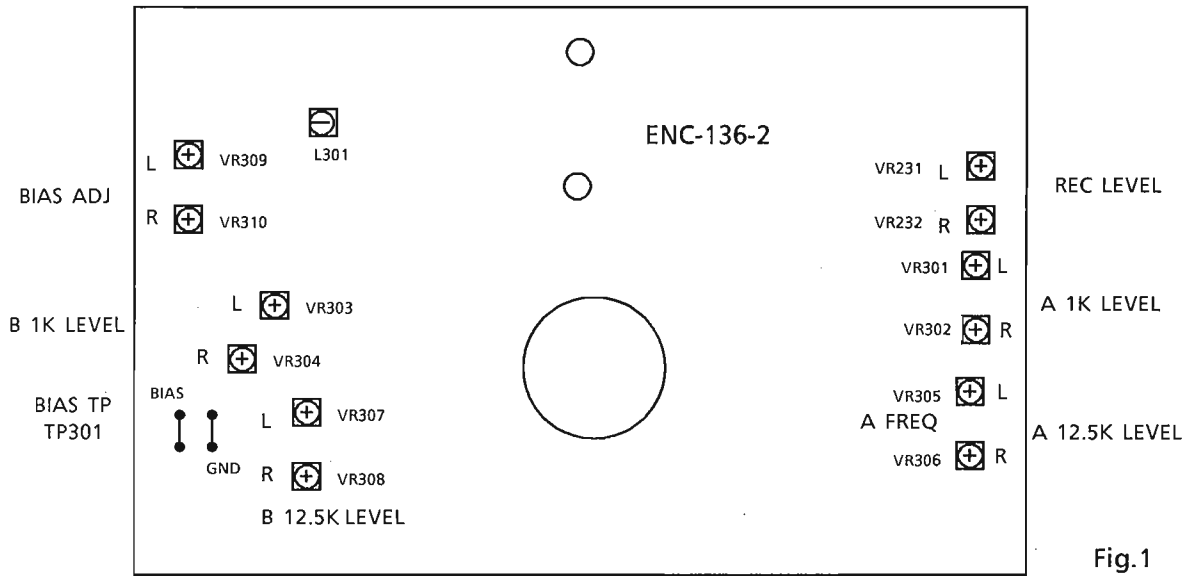
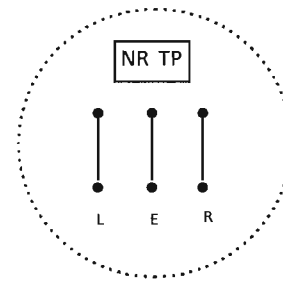
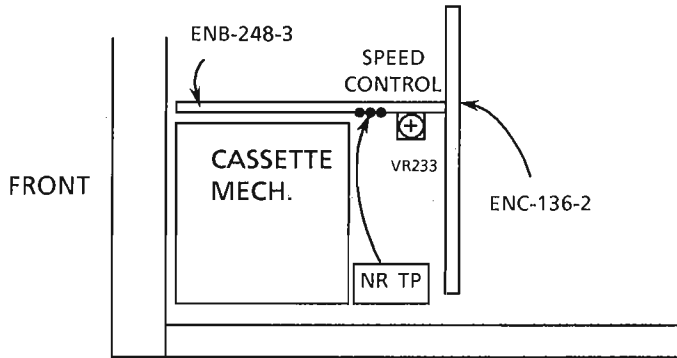

Fig.1



Speed Control PCB Fig.2

Deck section

1. Measuring instruments

- Audio frequency signal generator ( 0dbS output at the 600 ohm output terminal from 50Hz to 20KHz)
- Electronic voltmeter
- Frequency counter
- Wow & Flutter meter
- Distortion Meter with band pass filter
- Attenuator (600 ohm impedance)
- A resistor with 600Ω

Tape No.	Frequency	Level (Wow & Flutter)	Purpose
VTT-703L	10kHz	- 10dBs	Head azimuth , Frequency Response
VTT-712	3000Hz	0dBs 0.025%WRMS	Tape Speed , Wow & Flutter
VTT-724	1kHz	- 4dBs	Standard Level
TMT-6447	-	-	Blank Skip
TMT-6247 , TMT-6237	-	-	Music Scan
TMT-7088S	-	-	Recording standard Normal : UR
AC-712	-	-	Recording standard METAL :MA
AC-513	-	-	Recording standard CrO <sub>2</sub> :SA
TW-2111, TW-2121	-	-	Forward/reverse play torque measuring
TW-2231	-	-	Feed forward/rewind torque measuring
C-120 Tape	-	-	Confirming the tape running



## 2.Adjustment and repairing the mechanism

Item	Adjustment method	Standard value	Remarks
Head azimuth	<p>Deck A</p> <ol style="list-style-type: none"> <li>1. Connect an electronic voltmeter to the NR TP901 (figure 2) to playback VTT-703L.</li> <li>2. Adjust screw Ⓐ so that the indication of the voltmeter becomes maximum when PLAY (▶) is pressed.</li> <li>3. Adjust screw Ⓑ so that the indication of the voltmeter becomes maximum when PLAY (◀) is pressed.</li> </ol> <p>Deck B</p> <ol style="list-style-type: none"> <li>4. Adjust screw Ⓒ so that the indication of the voltmeter becomes maximum when PLAY (▶) is pressed.</li> <li>5. Adjust screw Ⓓ so that the indication of the voltmeter becomes maximum when PLAY (◀) is pressed.</li> <li>6. After making the adjustment, apply screw lock to prevent screws Ⓐ, Ⓑ, Ⓒ and Ⓓ coming loose.</li> </ol>	Maximum	<ol style="list-style-type: none"> <li>1. <b>Refer to figure 3.</b></li> <li>2. When the specified characteristic cannot be obtained because of head wear, excessive magnetization, etc., replace the head assembly and adjust the head azimuth. Also, perform the electric adjustment.</li> <li>3. When there is the difference of more than 3 ~ 4 dB between left and right output levels, replace the head assembly to avoid complaints.</li> </ol>
Playback torque	1. Measure the torque in the playback mode by the torque meter.	26 ~ 72 g-cm	When the standard torque cannot be obtained, replace the FR arm assembly or motor.
Fast forward torque	1. Measure the torque in the fast forward mode by the torque meter.	75 ~ 175 g-cm	When the standard torque cannot be obtained, replace the FR arm assembly or motor.
Rewind torque	1. Measure the torque in the rewind mode by the torque meter.	75 ~ 175 g-cm	When the standard torque cannot be obtained, replace the FR arm assembly or motor.
Wow & flutter	<ol style="list-style-type: none"> <li>1. Connect the wow &amp; flutter meter to the DOLBY TP (figure 2) and play back VTT-712.</li> <li>2. Its reading should be within 0.25% (WTD).</li> </ol>	Less than 0.25%	As a complaint may occur if the wow & flutter fluctuates by 0.1% even though it is allowed in the standard, repairing is required.

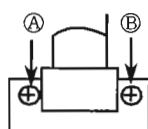

Deck A

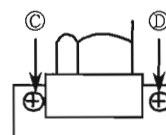

Deck B

Fig.3

### 3. Electrical Adjustments (Make the following adjustments after adjusting the head azimuth.)

In principle, the adjustments should be made in the following sequence.

Set the NR switch to OFF and the BEAT CUT switch to "1".

Adjustments marked with an asterisk (\*) should always be made after the head is replaced

**0dBs = 0.775V**

Item	Adjustment Method	Adjustment Location	Standard Value	Remarks
Tape Speed	1. Connect a frequency counter to the NR TP 901 (figure 2) and play back VTT-712. 2. Adjust the semi-fixed resistor VR901 on ENH-292 - 1 (figure 2).	VR233	3,000 Hz ± 10Hz	Connect a wow & flutter meter with a built-in frequency counter to the speaker terminals.
* Standard level (Playback Level)	1. Connect an electronic voltmeter to the NR TP901 (figure 2). Play back VTT-724 (1 kHz : - 4dBs) to adjust the semi - fixed resistors.	<b>Deck A</b> L: VR301 R: VR302 <b>Deck B</b> L: VR303 R: VR304	488mV (- 4dBs)	1) The playback level varies when the head is replaced so should be adjusted. Use an electronic voltmeter with an impedance of 100 kΩ or more.
* Playback Frequency Response	1. Connect an electronic voltmeter to the NR TP 901 (figure 2). 2. Play VTT-703L (10kHz : - 10dBs) and adjust semi-fixed resistors to obtain the standard values.	<b>Deck A</b> L: VR305 R: VR306 <b>Deck B</b> L: VR307 R: VR308	245mV (- 10dBs)	—
* Recording Bias Frequency	1. Connect a frequency counter to the BIAS TP (figure 2), and perform a recording to adjust bias frequency.	L301	105 kHz ± 5 kHz	
* Record / Play Frequency Response (Bias current)	1. Supply 1kHz and 12.5kHz with 30mV signals to AUX terminals respectively to record them. 2. Connect an electronic voltmeter to the NR TP901 (figure 2) to confirm the recorded values. 3. If the values are not satisfied, adjust the semi-fixed resistors and record the signal again to confirm the recorded values.	L: VR309 R: VR310	0 ± 2 dB with 1 kHz as the standard.	<b>Refer to figure 4 below.</b> 1) The recording and playback frequency response of a cassette deck are adjusted by adjusting the bias. 2) Perform the adjustment with normal tape and confirm that the values are within the range for metal tape.

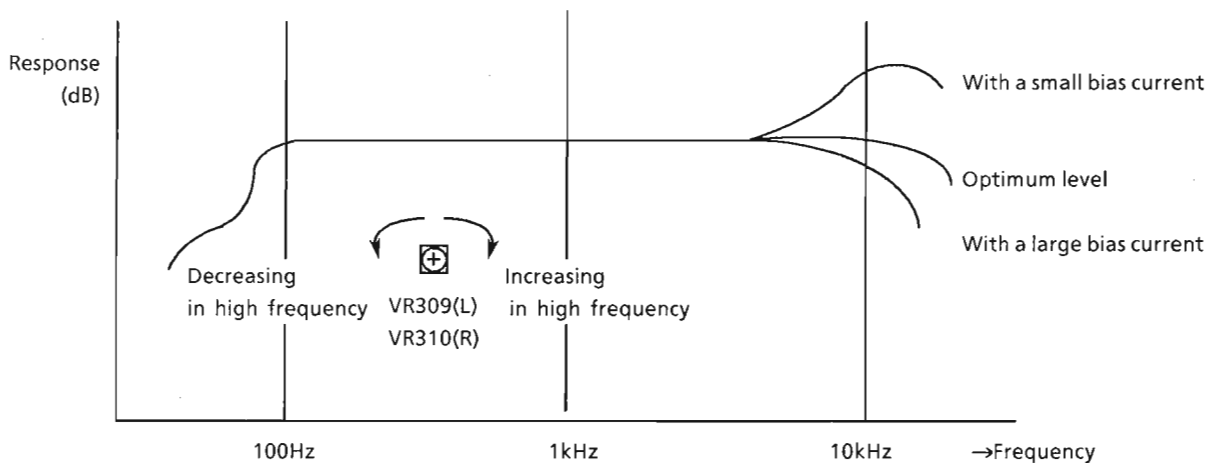
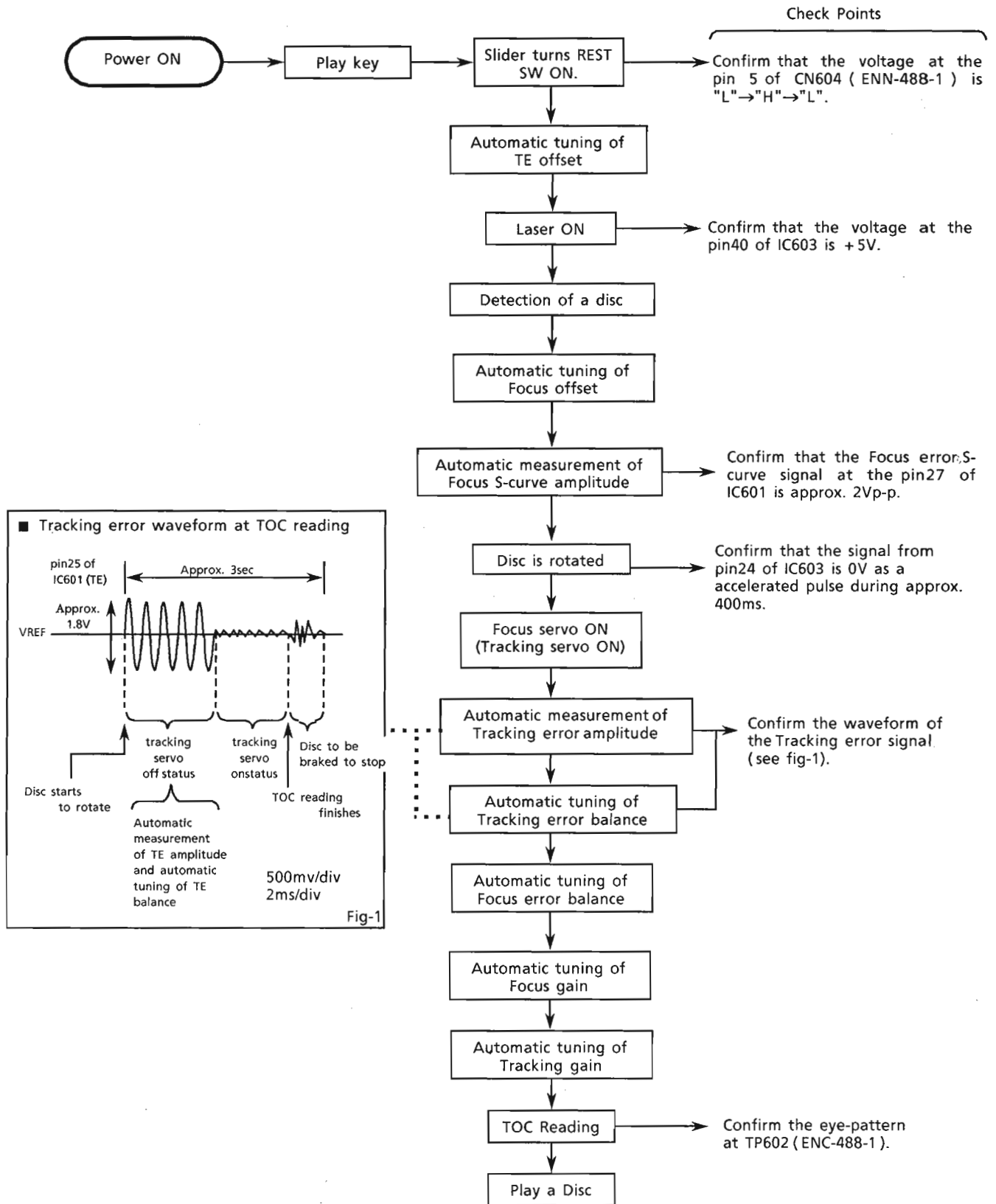

Fig.4

# Flow of Functional Operation Until TOC is Read



# Maintenance of Laser Pickup

**(1) Cleaning the pick up lens**

Before you replace the pick up, please try to clean the lens with a alcohol soaked cotton swab.

**(2) Life of the laser diode (Fig.1)**

When the life of the laser diode has expired, the following symptoms will appear.

- (1) The level of RF output (EFM output: amplitude of eye pattern) will be low.

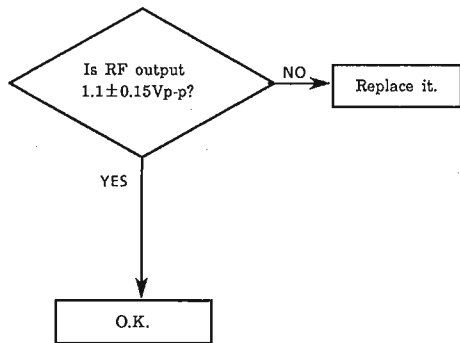

(Fig.1)

**(3) Semi-fixed resistor on the APC PC board**

The semi-fixed resistor on the APC printed circuit board which is attached to the pickup is used to adjust the laser power. Since this adjustment should be performed to match the characteristics of the whole optical block, do not touch the semi-fixed resistor.

If the laser power is lower than the specified value, the laser diode is almost worn out, and the laser pickup should be replaced.

If the semi-fixed resistor is adjusted while the pickup is functioning normally, the laser pickup may be damaged due to excessive current.

## Replacement of Laser Pickup

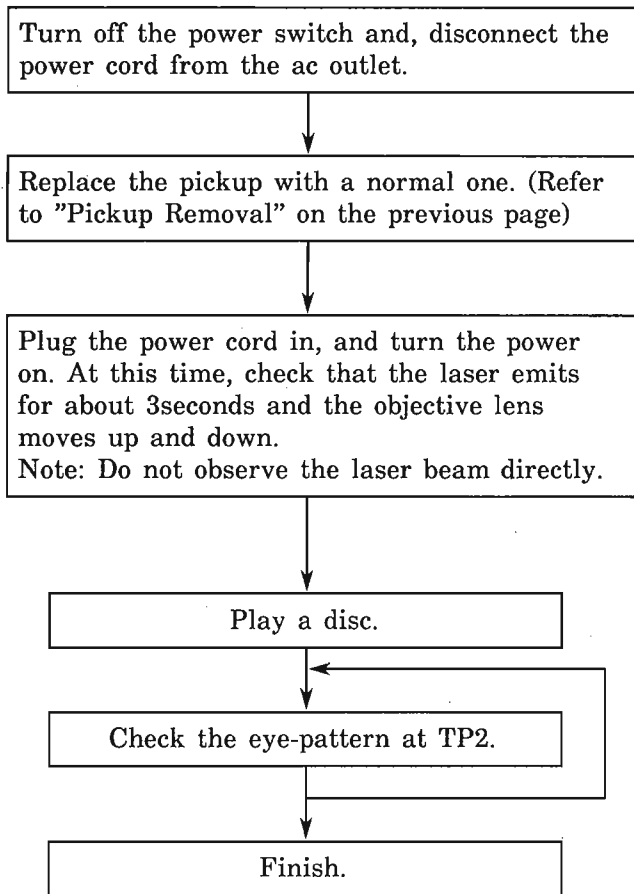

## Self-diagnosis for pickup

From DCS output, this model reads automatically adjusted data for CD so that the pickup can be judged defective or not. Following shows its details.

### 1. Necessary items

- ① DCS → 232C Converting board (No.EBSJ1022)
- ② 232C cord (straight)
- ③ Floppy disc for self-diagnosis (No.EBSJ1022)
- ④ DCS cord
- ⑤ Power supply DC 6.3V (AA-SV11U)
- ⑥ Cord of Power supply E407992-001
- ⑦ CD (without scratches or damage)

### 2. Connection

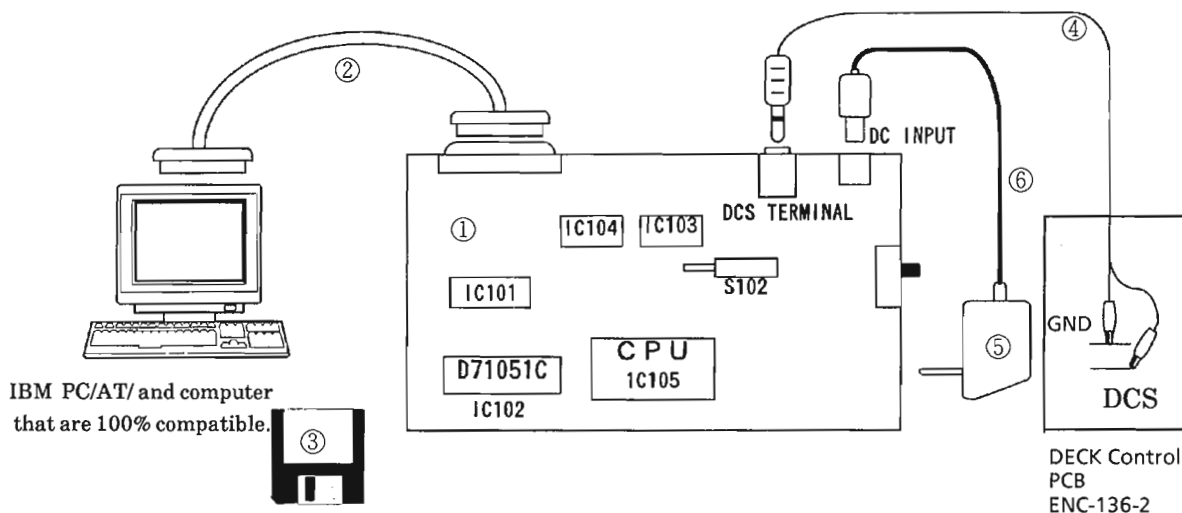

### 3. Procedure to use CD self-diagnosis jig by IBM PC

Two com pins are frequently adopted in recent IBM AT and its substitute RS232C port.

This jig can also use both COM1 and COM2.

DEFAULT is COM1. Indicate "2" to the option only for COM2.

When COM1 is used,...

I AUTO 01

When COM2 is used,...

I AUTO 02

[ NOTE ] Press ESC key to stop processing during the operation.

Contents of the attached floppy IBM self-diagnosis program VER.1.00 Execution file.

( Mistake the conection/Mistake the polarity )

## 4. Judgment

To judge whether pickup is defective or not, firstly process of automatic adjustment is checked by automatic adjustment flag. And, the value(automatic adjustment value for focus gain) displayed on the screen is used for its final judgment.

It is supposed that the pickup is defective or the signal path is faulty if the Flag1 or Flag0 indicates not "F" but a figure.

(See the following example.)

Flag1	Flag0	Details	Supposed cause
0	0	Automatic adjustment for tracking offset is failed.	The automatic adjustment is not completed. (Trouble in circuit.)
0	1	Automatic adjustment for focus offset is failed. (Disc does not rotate.)	The lens does not move. (Power supply is not turned on. Wire is cut.)
0	3	Automatic rough adjustment for focus gain is failed.	
0	7	Automatic rough adjustment for tracking gain is failed. (The focus and tracking gain are not locked though the disc rotates.)	Laser deterioration (low RF signal output). Offset beam.
0	F	Disc rotates, focus and tracking gain are locked and automatic rough adjustment for tracking gain is also completed though automatic adjustment for tracking balance is failed.	Laser deterioration (low RF signal output). Offset beam.
1	F	Automatic adjustment for focus balance is failed. (TOC is not read though the disc rotates.)	RF signal output is low. Tracking loop is not turned on. RF jitter is too much.
3	F	Automatic rough adjustment for focus gain is failed.	
7	F	Automatic rough adjustment for tracking gain is failed.	
F	F	All automatic adjustments are completed.	

The pickup is judged defective though the Flag0 and Flag1 indicate "F" and those adjustments are completed if the adjustment value exceeds 19dB.

# Block Diagrams

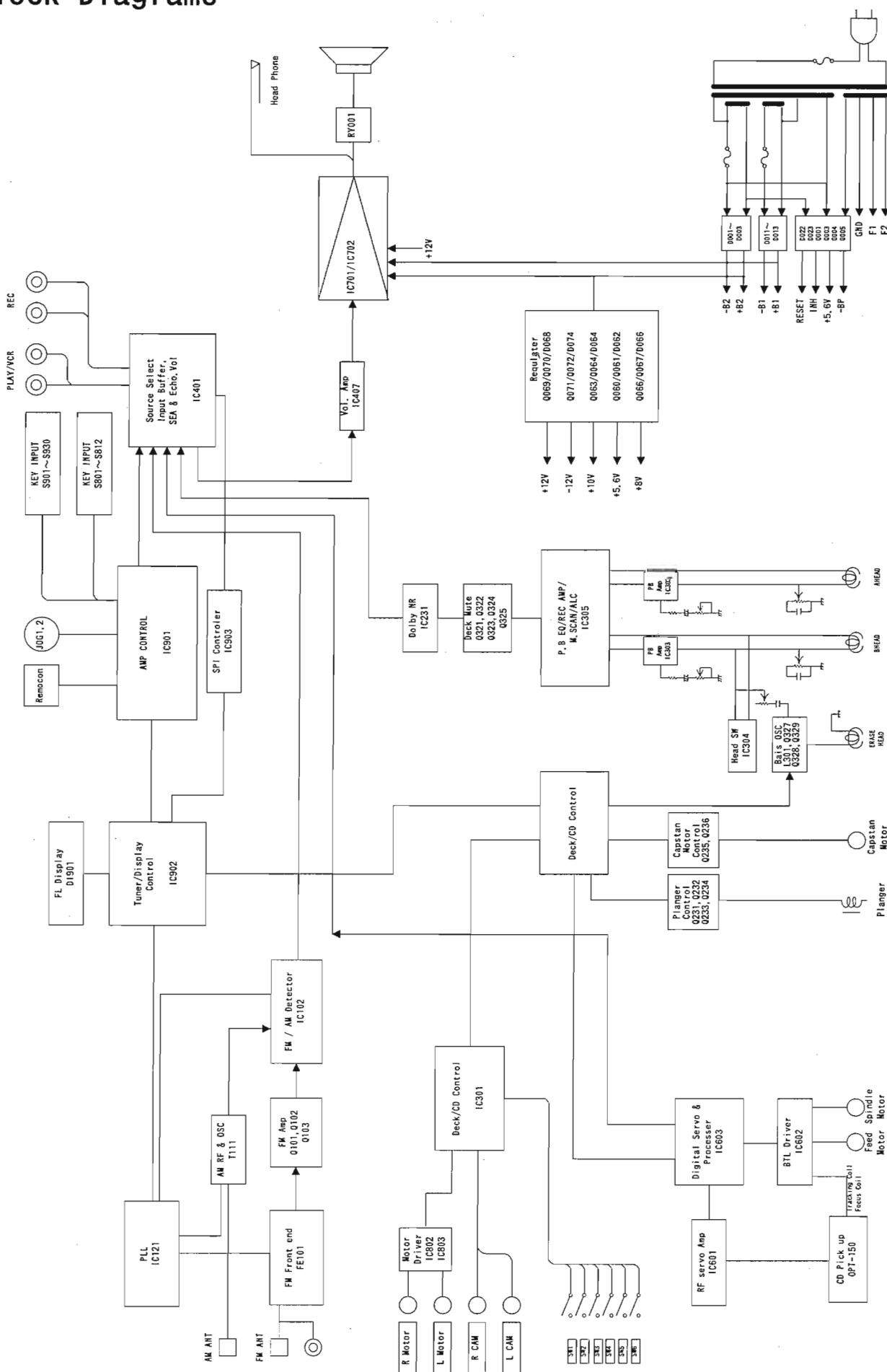

— MEMO —



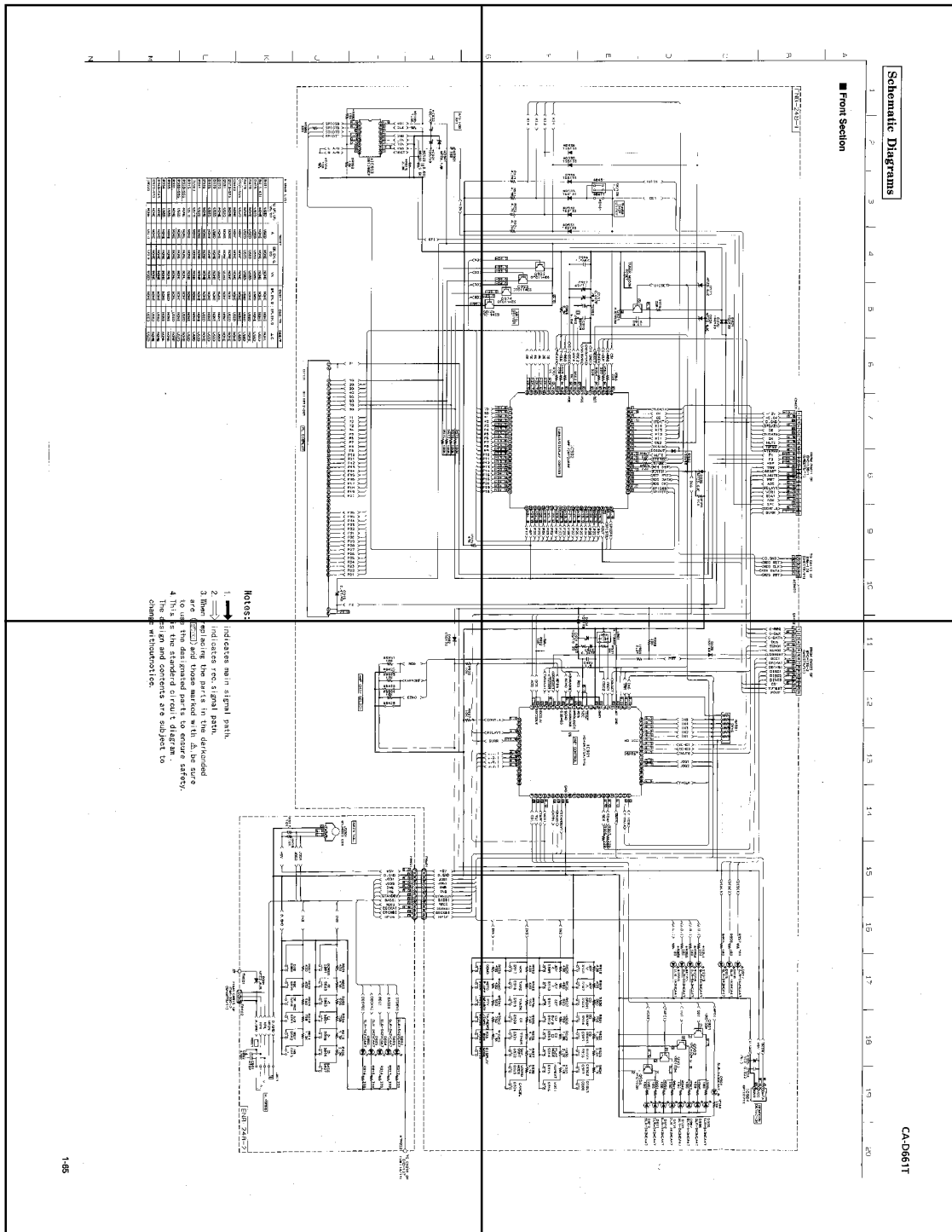



# Schematic Diagrams

## Front Section

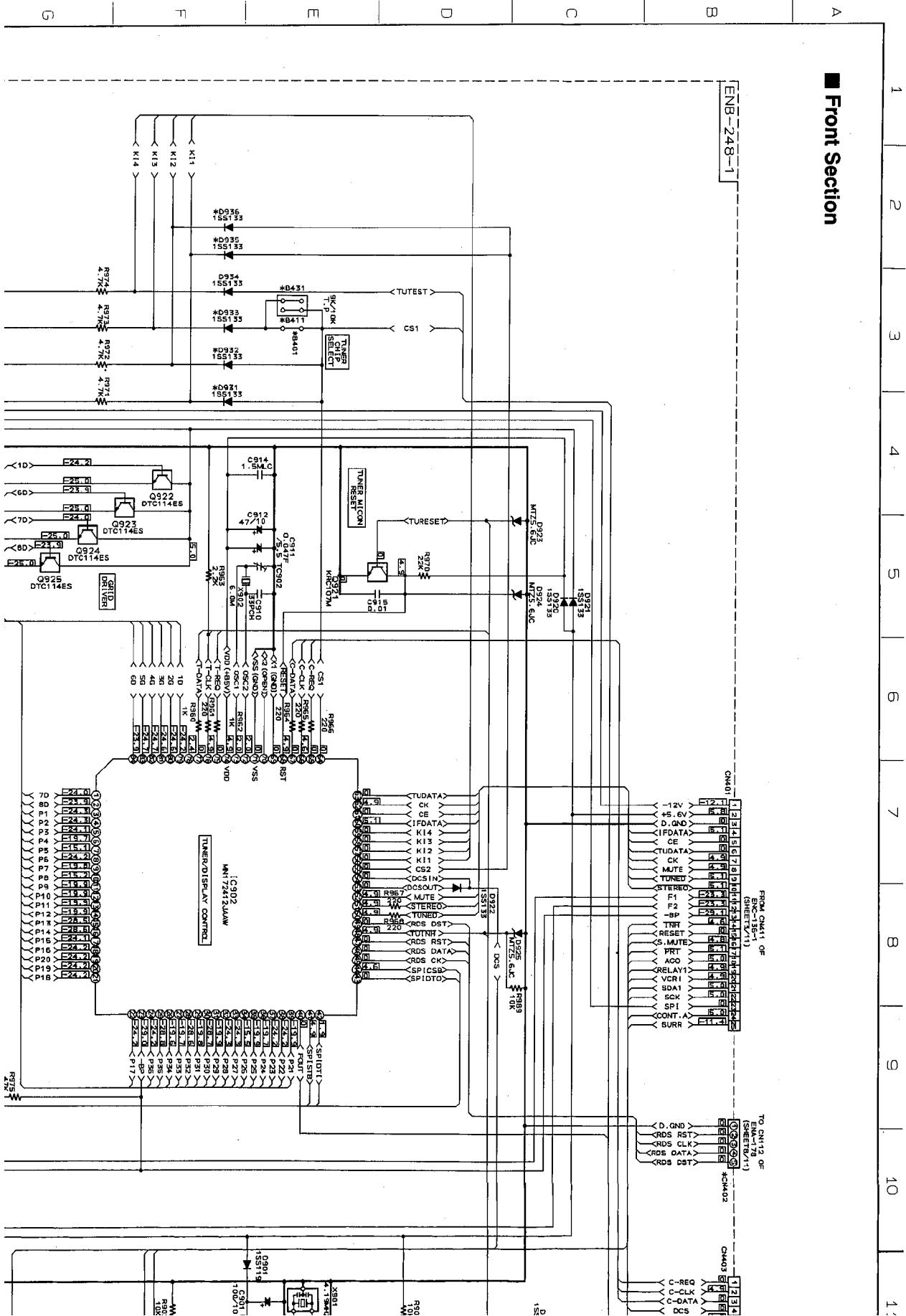

G H I J K L M N

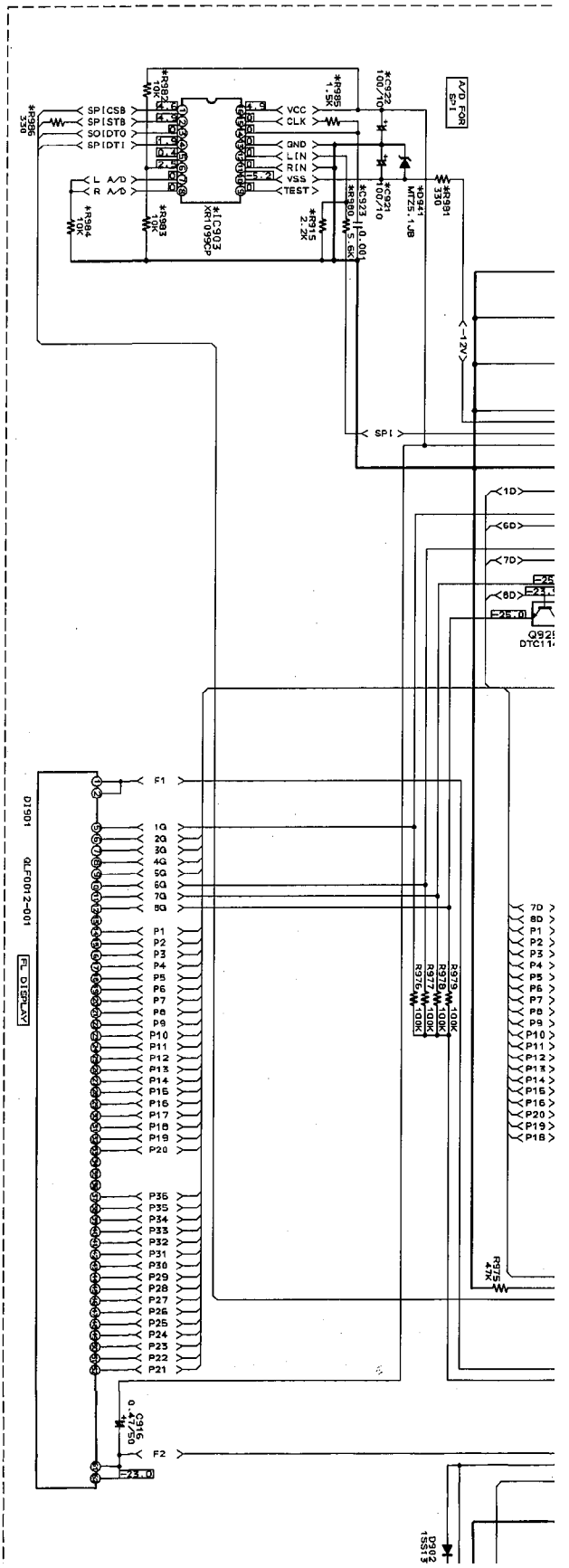

MARK LIST

U, L, U, P, S, O	A	EF, EN, G	VX	DF, EN, G	EF, EN, G	DF, EN, G	J, C
B441	USED	NONE	NONE	NONE	NONE	NONE	NONE
B441.431	NONE	NONE	NONE	NONE	NONE	NONE	NONE
B442	USED	USED	USED	USED	USED	USED	USED
B443	USED	USED	USED	USED	USED	USED	USED
B448	NONE	NONE	NONE	NONE	NONE	NONE	NONE
B449	USED	USED	USED	USED	USED	USED	USED
B451-423	USED	USED	USED	USED	USED	USED	USED
D1402	NONE	NONE	NONE	NONE	NONE	NONE	NONE
D1402-915	USED	USED	USED	USED	USED	USED	USED
D931	NONE	NONE	NONE	NONE	NONE	NONE	NONE
D932	NONE	NONE	NONE	NONE	NONE	NONE	NONE
D933	USED	USED	USED	USED	USED	USED	USED
D935	USED	USED	USED	USED	USED	USED	USED
D936	NONE	NONE	NONE	NONE	NONE	NONE	NONE
D941	USED	USED	USED	USED	USED	USED	USED
D942	USED	USED	USED	USED	USED	USED	USED
D943	USED	USED	USED	USED	USED	USED	USED
D944	USED	USED	USED	USED	USED	USED	USED
D945	USED	USED	USED	USED	USED	USED	USED
D946	USED	USED	USED	USED	USED	USED	USED
D947	USED	USED	USED	USED	USED	USED	USED
D948	USED	USED	USED	USED	USED	USED	USED
D949	USED	USED	USED	USED	USED	USED	USED
D950	USED	USED	USED	USED	USED	USED	USED
D951	USED	USED	USED	USED	USED	USED	USED
D952	USED	USED	USED	USED	USED	USED	USED
D953	USED	USED	USED	USED	USED	USED	USED
D954	USED	USED	USED	USED	USED	USED	USED
D955	USED	USED	USED	USED	USED	USED	USED
D956	USED	USED	USED	USED	USED	USED	USED
D957	USED	USED	USED	USED	USED	USED	USED
D958	USED	USED	USED	USED	USED	USED	USED
D959	USED	USED	USED	USED	USED	USED	USED
D960	USED	USED	USED	USED	USED	USED	USED
D961	USED	USED	USED	USED	USED	USED	USED
D962	USED	USED	USED	USED	USED	USED	USED
D963	USED	USED	USED	USED	USED	USED	USED
D964	USED	USED	USED	USED	USED	USED	USED
D965	USED	USED	USED	USED	USED	USED	USED
D966	USED	USED	USED	USED	USED	USED	USED
D967	USED	USED	USED	USED	USED	USED	USED
D968	USED	USED	USED	USED	USED	USED	USED
D969	USED	USED	USED	USED	USED	USED	USED
D970	USED	USED	USED	USED	USED	USED	USED
D971	USED	USED	USED	USED	USED	USED	USED
D972	USED	USED	USED	USED	USED	USED	USED
D973	USED	USED	USED	USED	USED	USED	USED
D974	USED	USED	USED	USED	USED	USED	USED
D975	USED	USED	USED	USED	USED	USED	USED
D976	USED	USED	USED	USED	USED	USED	USED
D977	USED	USED	USED	USED	USED	USED	USED
D978	USED	USED	USED	USED	USED	USED	USED
D979	USED	USED	USED	USED	USED	USED	USED
D980	USED	USED	USED	USED	USED	USED	USED
D981	USED	USED	USED	USED	USED	USED	USED
D982	USED	USED	USED	USED	USED	USED	USED
D983	USED	USED	USED	USED	USED	USED	USED
D984	USED	USED	USED	USED	USED	USED	USED
D985	USED	USED	USED	USED	USED	USED	USED
D986	USED	USED	USED	USED	USED	USED	USED
D987	USED	USED	USED	USED	USED	USED	USED
D988	USED	USED	USED	USED	USED	USED	USED
D989	USED	USED	USED	USED	USED	USED	USED
D990	USED	USED	USED	USED	USED	USED	USED
D991	USED	USED	USED	USED	USED	USED	USED
D992	USED	USED	USED	USED	USED	USED	USED
D993	USED	USED	USED	USED	USED	USED	USED
D994	USED	USED	USED	USED	USED	USED	USED
D995	USED	USED	USED	USED	USED	USED	USED
D996	USED	USED	USED	USED	USED	USED	USED
D997	USED	USED	USED	USED	USED	USED	USED
D998	USED	USED	USED	USED	USED	USED	USED
D999	USED	USED	USED	USED	USED	USED	USED
D1000	USED	USED	USED	USED	USED	USED	USED

Notes:

1. indic
2. indic
3. When replac are ( ) to use the
4. This is the design change with

CA-D661T

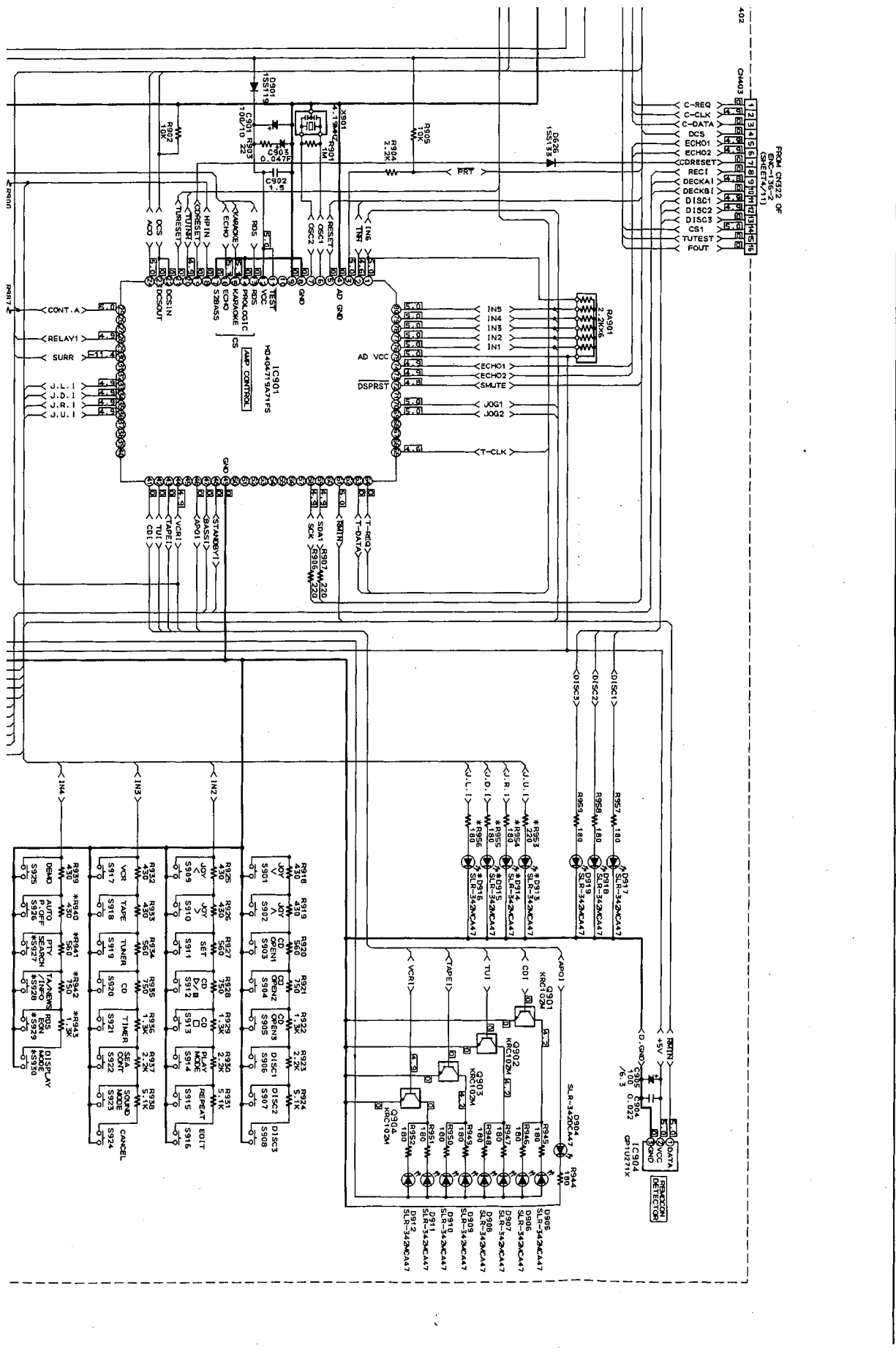

FROM ONE22 OF  
ENC-136-2  
SHEET 7/11



P1-66-a

P1-66-b

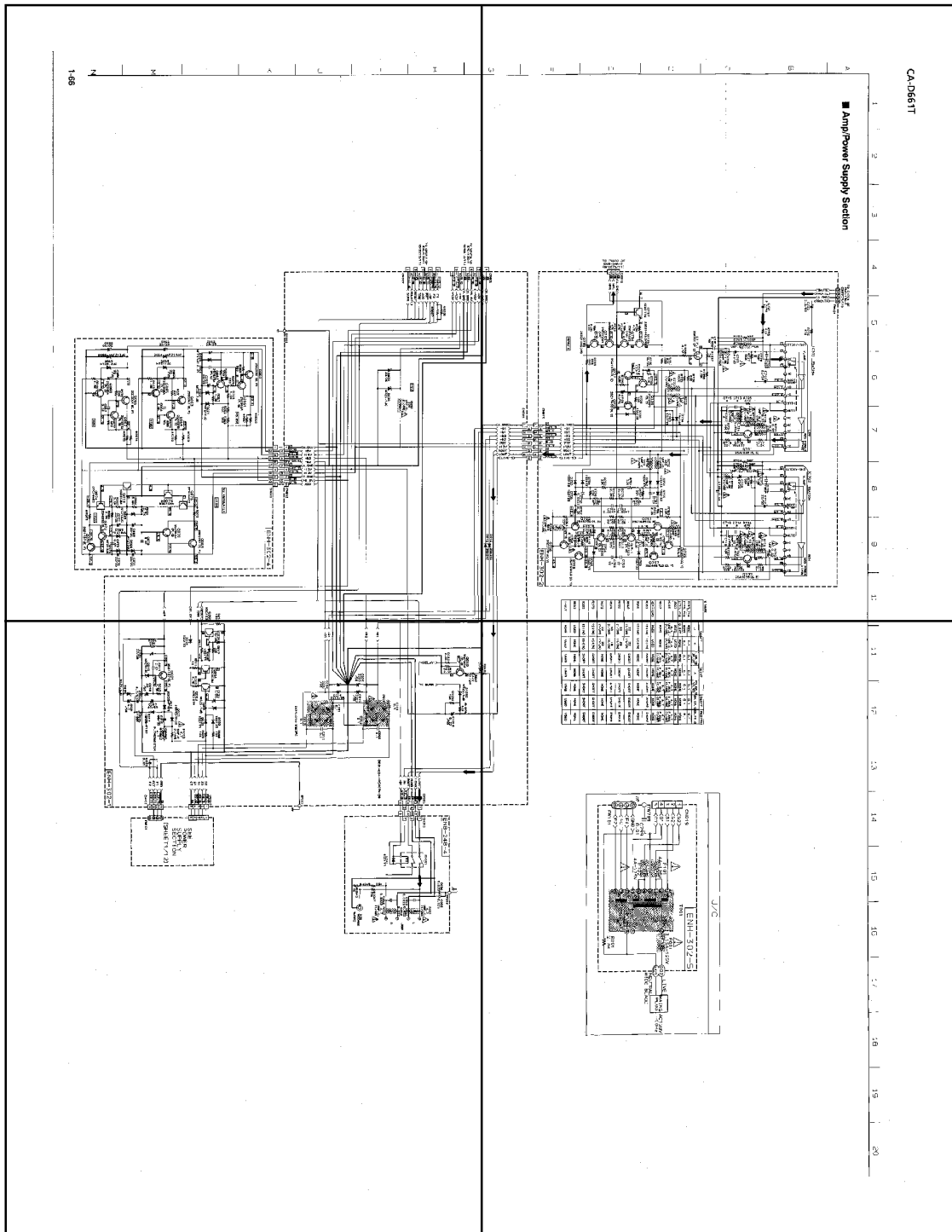

P1-66-c

P1-66-d

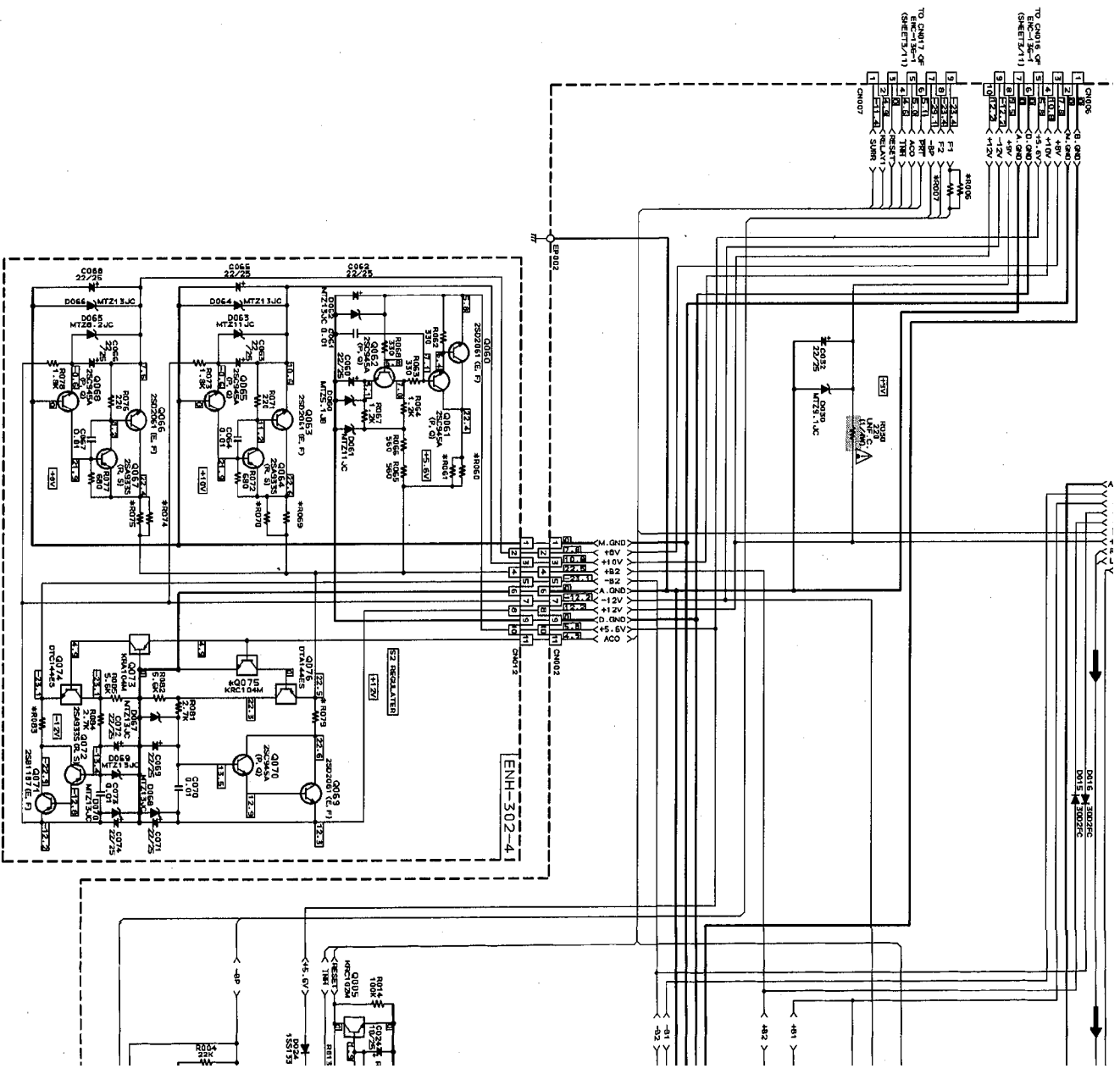



■ Amp/Power Supply Section

1 2 3 4 5 6 7 8 9 10

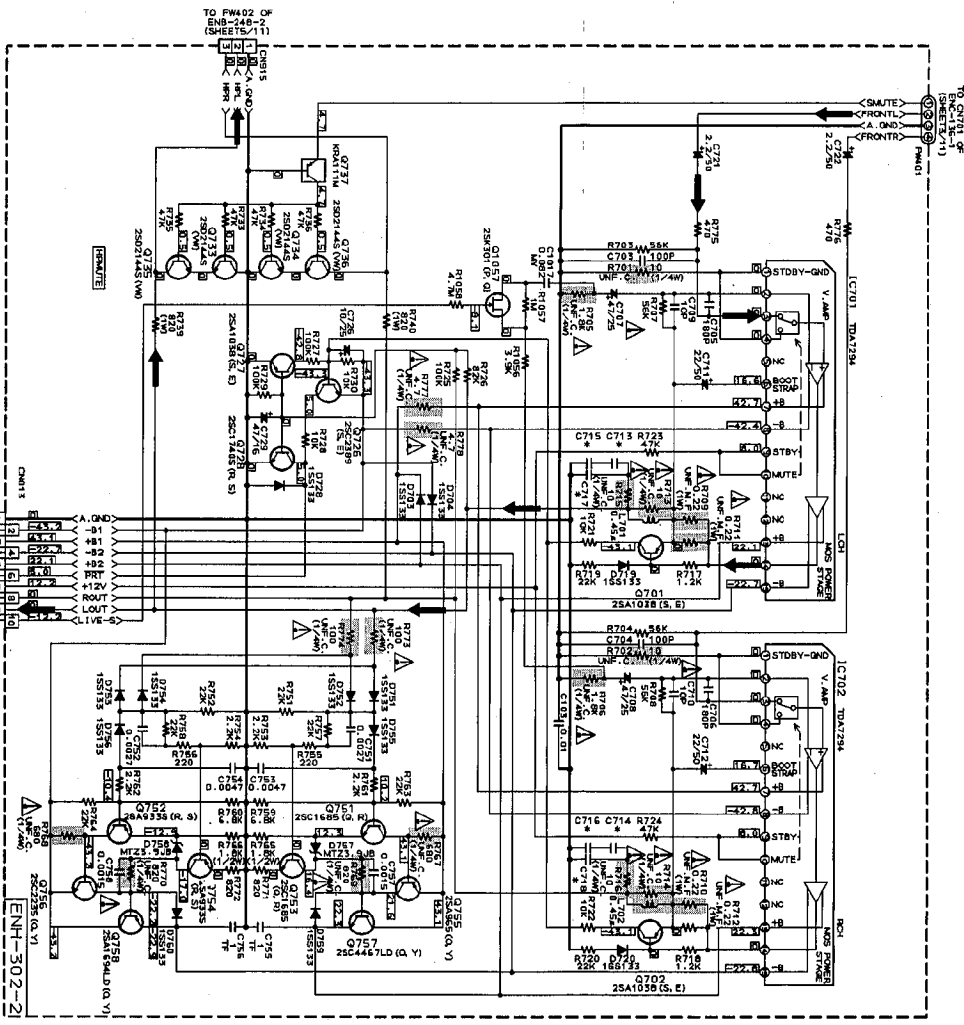

\* MARK

MARK	Y	C
C713, 714	NONE	0.1
C715, 716	NONE	0.1
C717, 718	0.047	NONE
R802	USED	USED
R806	1/2W, 2	1/2W, 2
R807	1/2W, 1	1/2W, 1
R807-CMS	USED	NONE
R808	1/2W, 1	1/2W, 1
R809	1/2W, 1	1/2W, 1
R851	1/2W, 1	1/2W, 1
R853	1/2W, 1	1/2W, 1
R870	33	33
R871	1/2W, 1	1/2W, 1
R874	1/2W, 1	1/2W, 1
R875	22	22
R879	12.0M	12.0M
R883	15.0W	15.0W
R885	NONE	NONE
T802	USED	USED

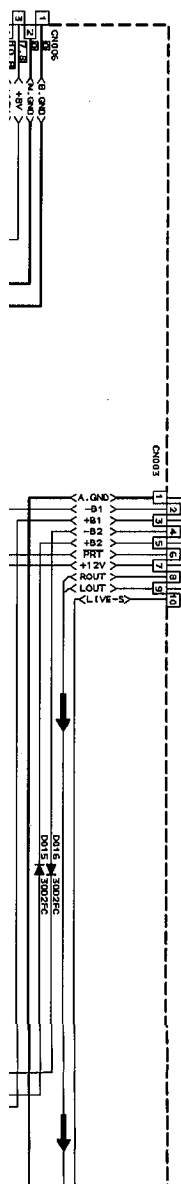

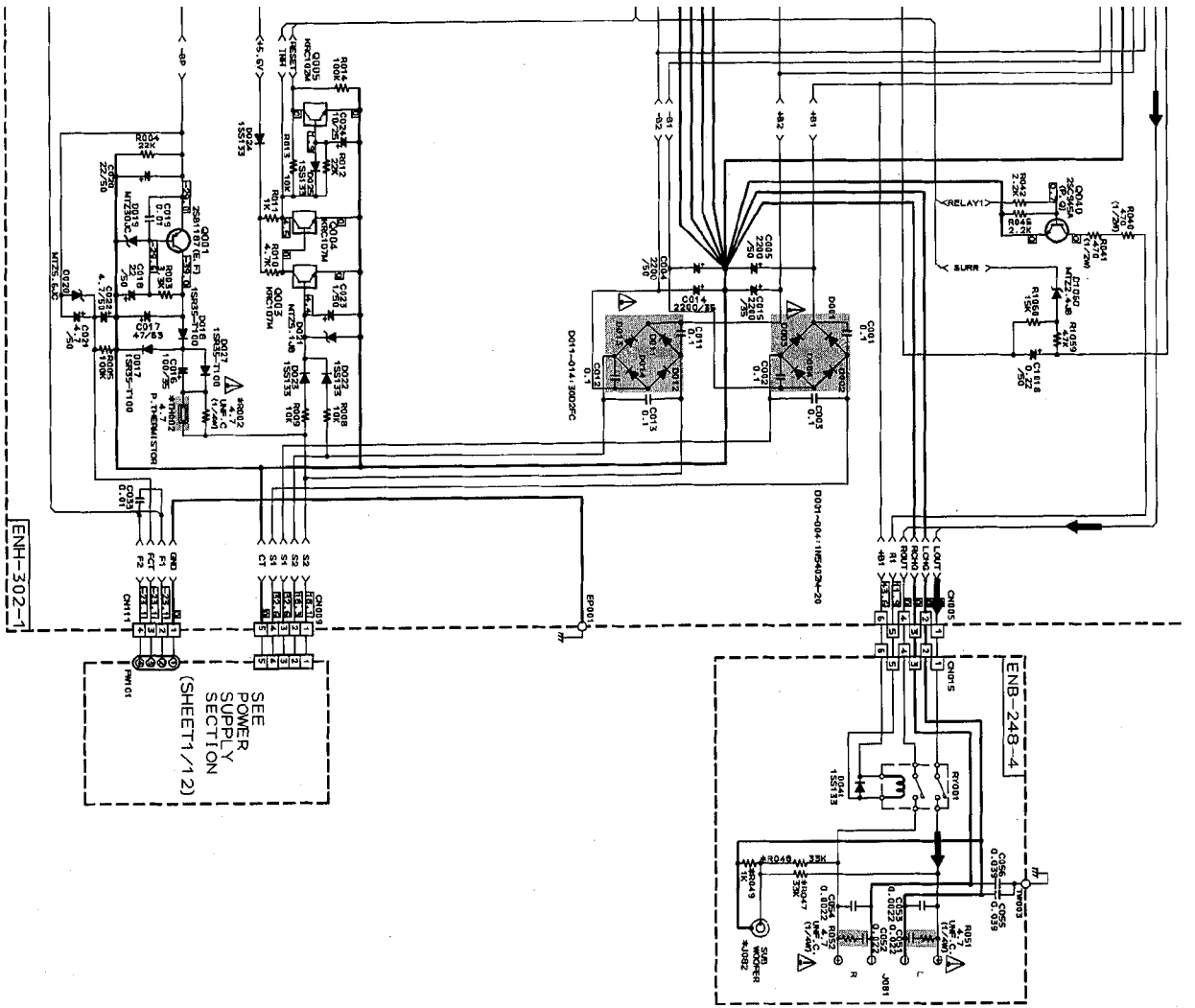

1. MARK

	RESIST	RESIST	RESIST	RESIST	RESIST	RESIST
	J	G	HUB LINE	A	RESIST	RESIST
CT13, 714	NONE	0.1	0.1	0.1	0.1	0.1
CT15, 715	NONE	0.1	0.1	0.1	0.1	0.1
CT17, 717	NONE	0.1	0.1	0.1	0.1	0.1
RO02	USED	USED	NONE	NONE	NONE	NONE
RO06	1.5 (1W)	1.5 (1W)	1.5 (1W)	1.5 (1W)	1.5 (1W)	1.5 (1W)
RO07	NONE	NONE	1.5 (1W)	1.5 (1W)	1.5 (1W)	1.5 (1W)
RO07-049	USED	USED	NONE	NONE	NONE	NONE
RO08	1.8 (1W)	1.8 (1W)	SHORT	SHORT	SHORT	SHORT
RO09	2.2 (1/2W)	2.2 (1/2W)	SHORT	SHORT	SHORT	SHORT
RO10	2.2 (1/2W)	2.2 (1/2W)	SHORT	SHORT	SHORT	SHORT
RO11	2.2 (1/2W)	2.2 (1/2W)	SHORT	SHORT	SHORT	SHORT
RO12	1.5 (1W)	1.5 (1W)	SHORT	SHORT	SHORT	SHORT
RO13	1.5 (1W)	1.5 (1W)	SHORT	SHORT	SHORT	SHORT
RO14	1.5 (1W)	1.5 (1W)	SHORT	SHORT	SHORT	SHORT
RO15	2.2 (1/2W)	2.2 (1/2W)	NONE	NONE	NONE	NONE
RO16	2.2 (1/2W)	2.2 (1/2W)	SHORT	SHORT	SHORT	SHORT
RO17	1.2 (2W)	1.2 (2W)	SHORT	SHORT	SHORT	SHORT
RO18	1.5 (1W)	1.5 (1W)	SHORT	SHORT	SHORT	SHORT
RO19	1.5 (1W)	1.5 (1W)	SHORT	SHORT	SHORT	SHORT
RO20	1.5 (1W)	1.5 (1W)	SHORT	SHORT	SHORT	SHORT
TR002	NONE	USED	USED	USED	USED	USED

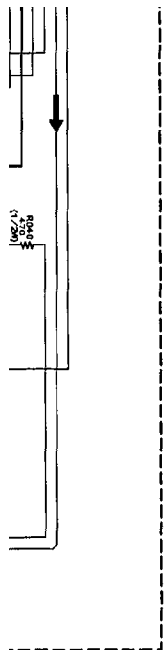
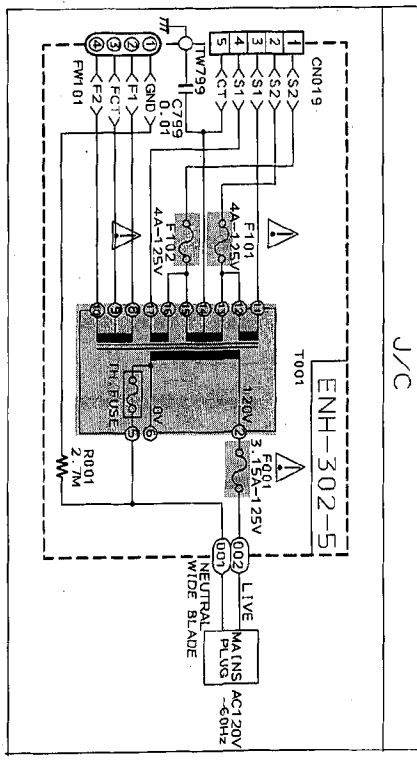



P1-67-a

P1-67-b

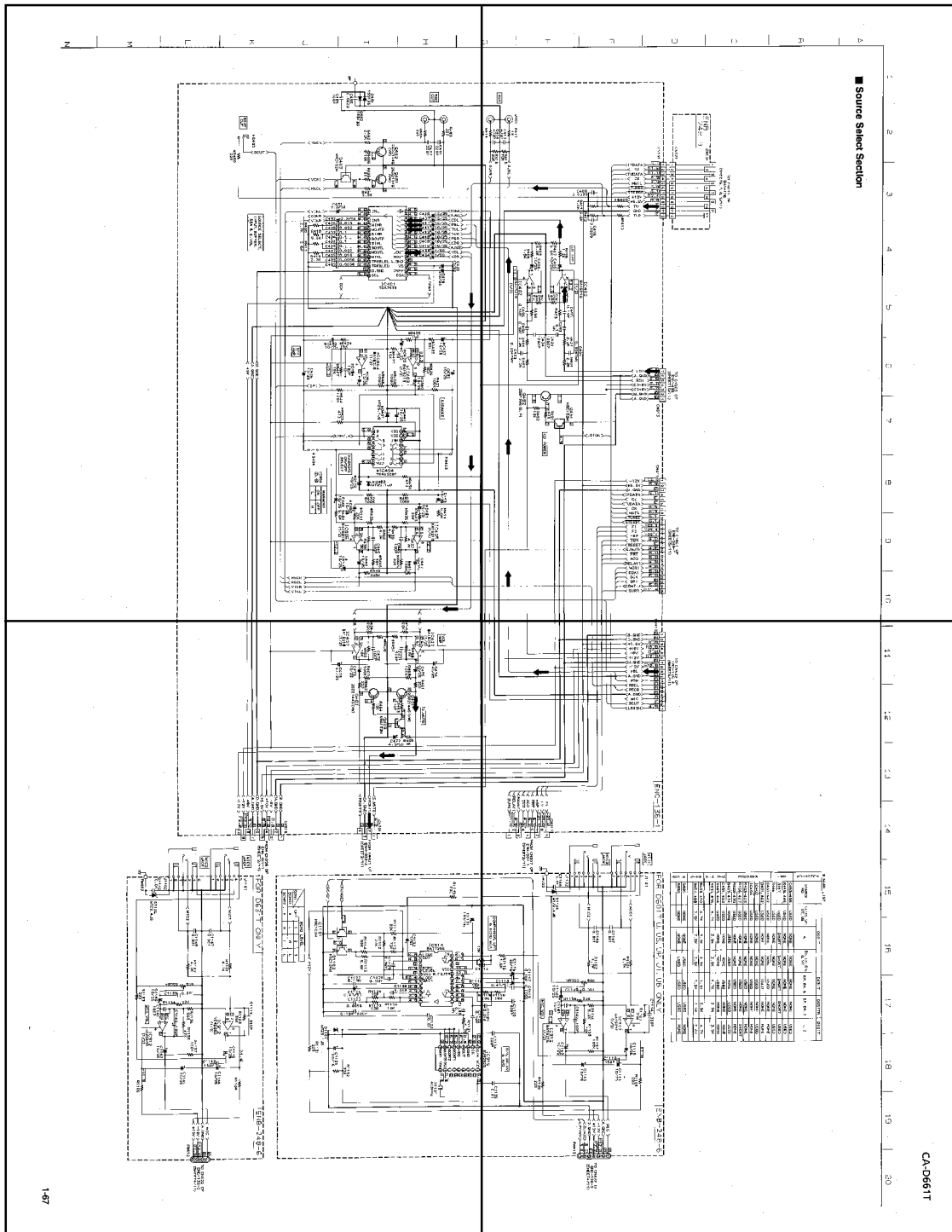

P1-67-c

P1-67-d

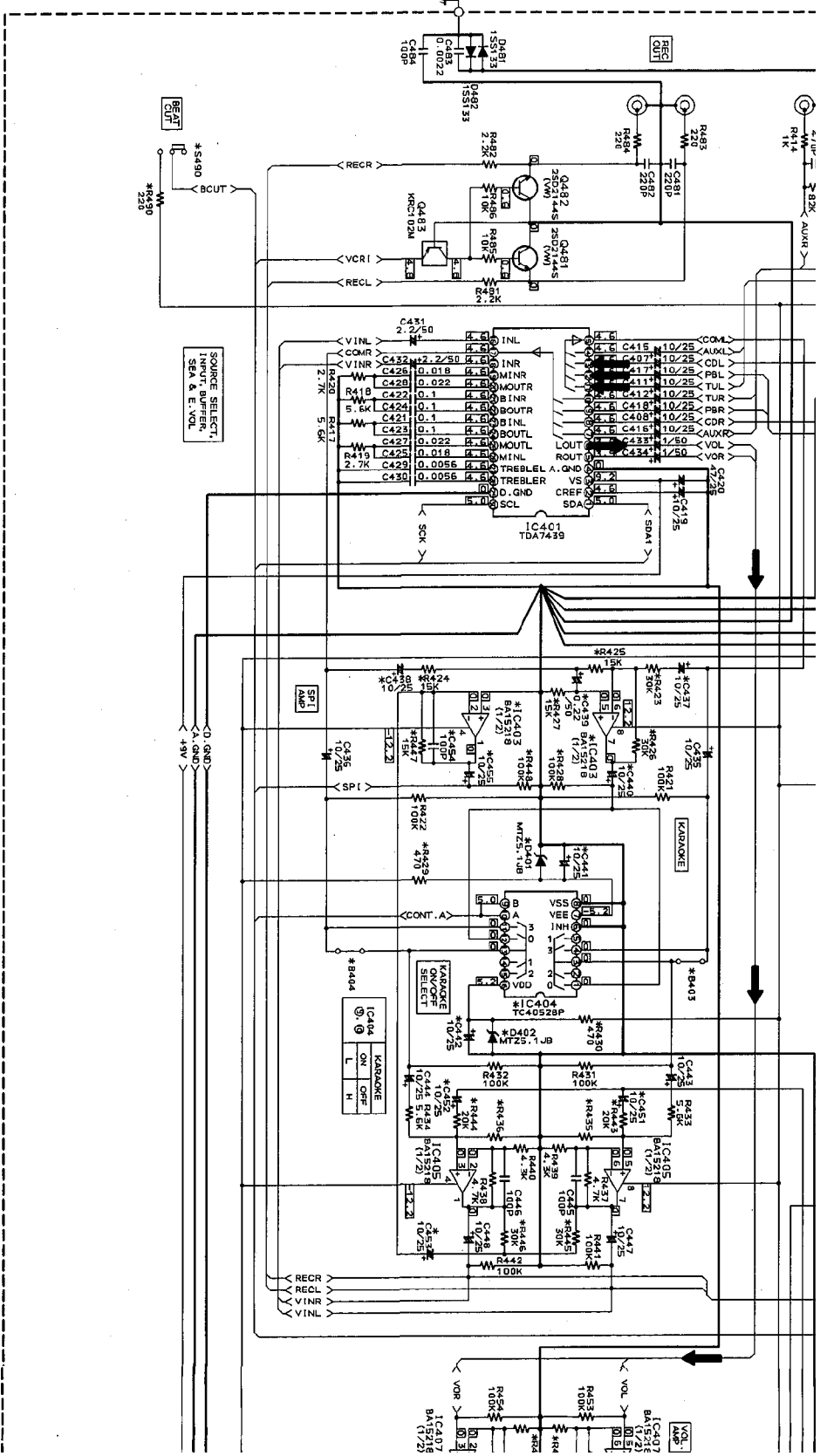

1 2 3 4 5 6 7 8 9 10

### Source Select Section

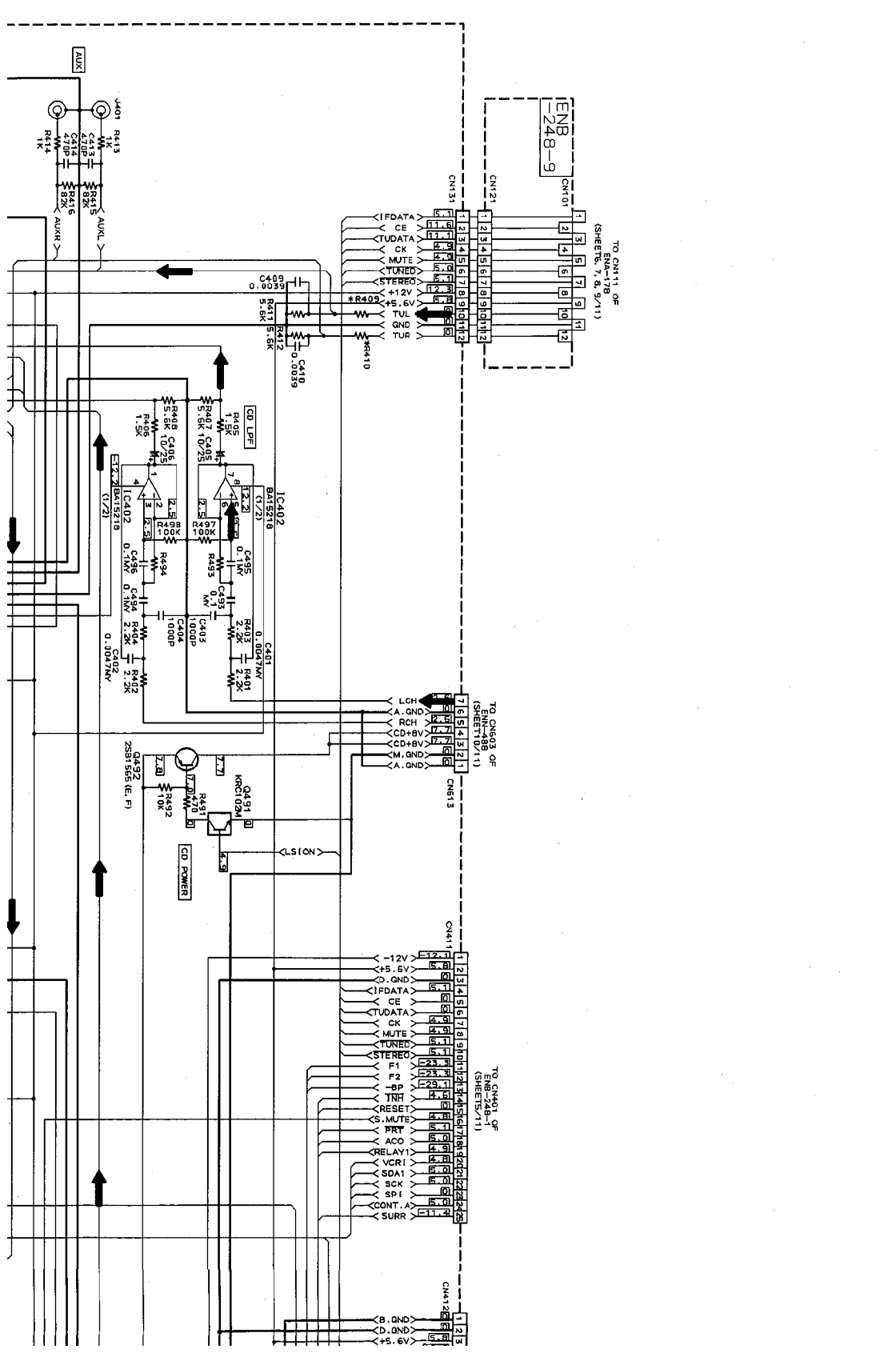

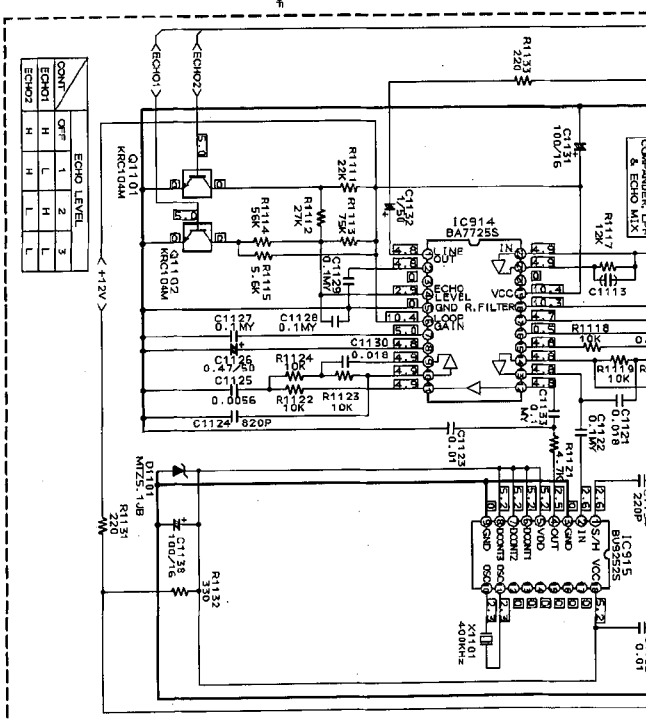
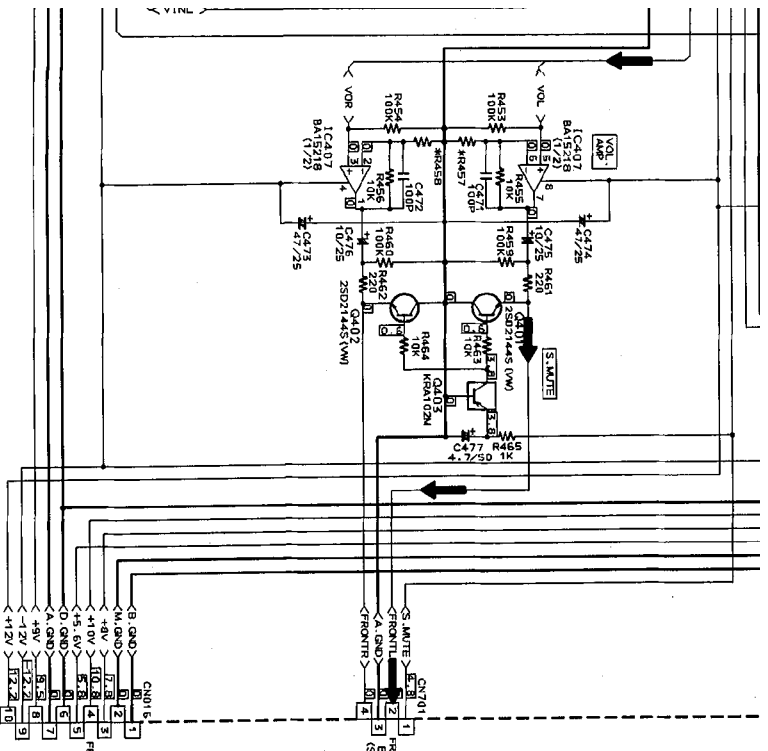

CON'T	ECHO LEVEL	1	2	3
ECHO1	H	L	H	L
ECHO2	H	H	L	L

FOR D631T ONLY

ENB-248-6

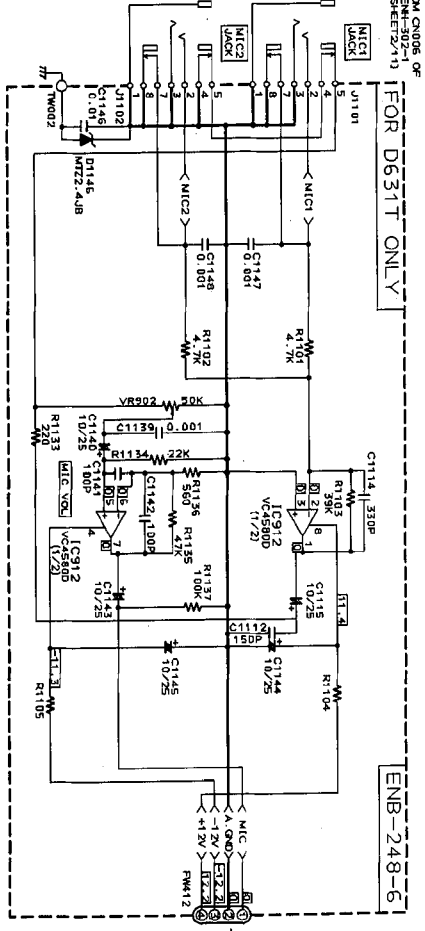

TO QM422 OF ENC-135-2 (SHEET 4/11)







P1-68-a

P1-68-b

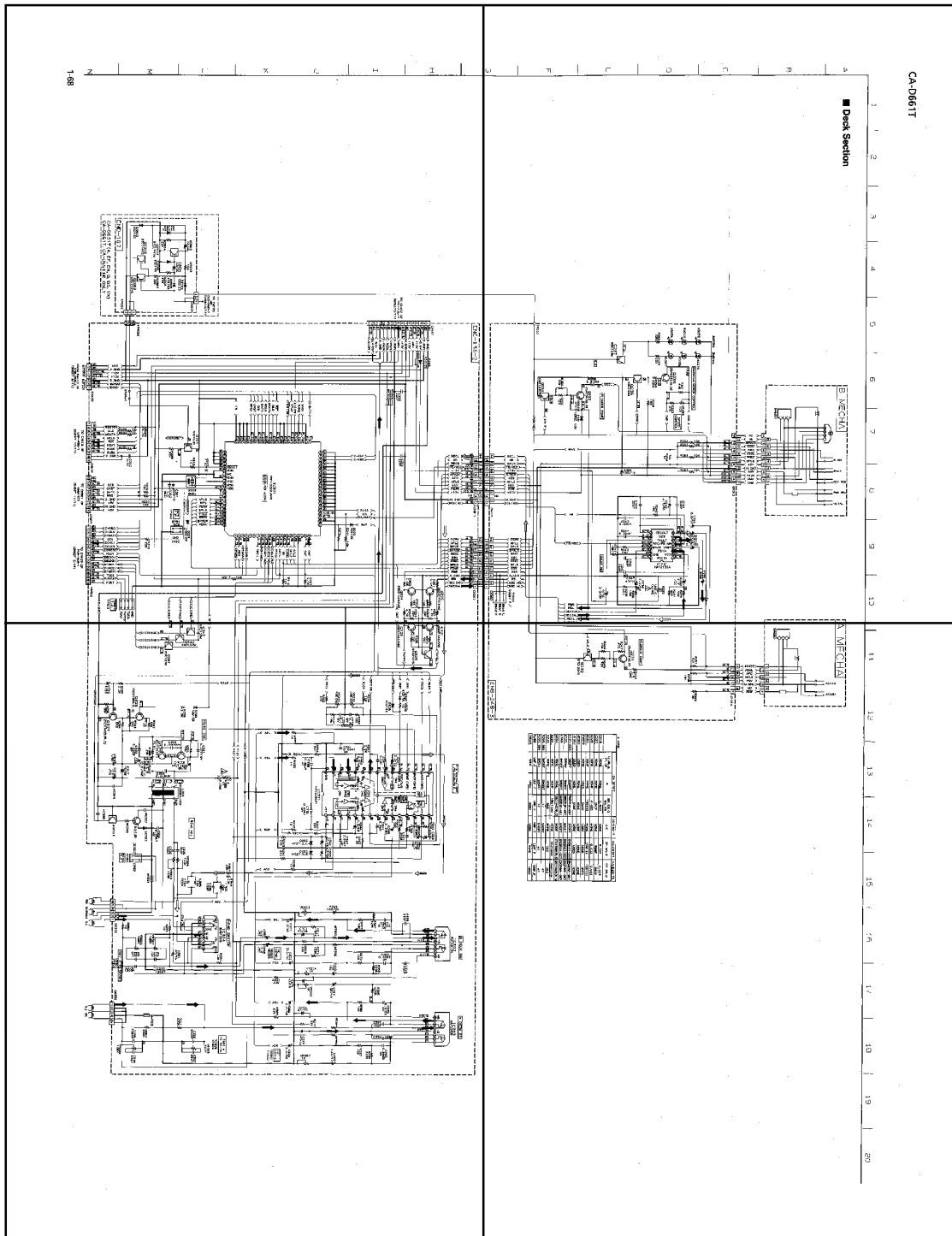

P1-68-c

P1-68-d

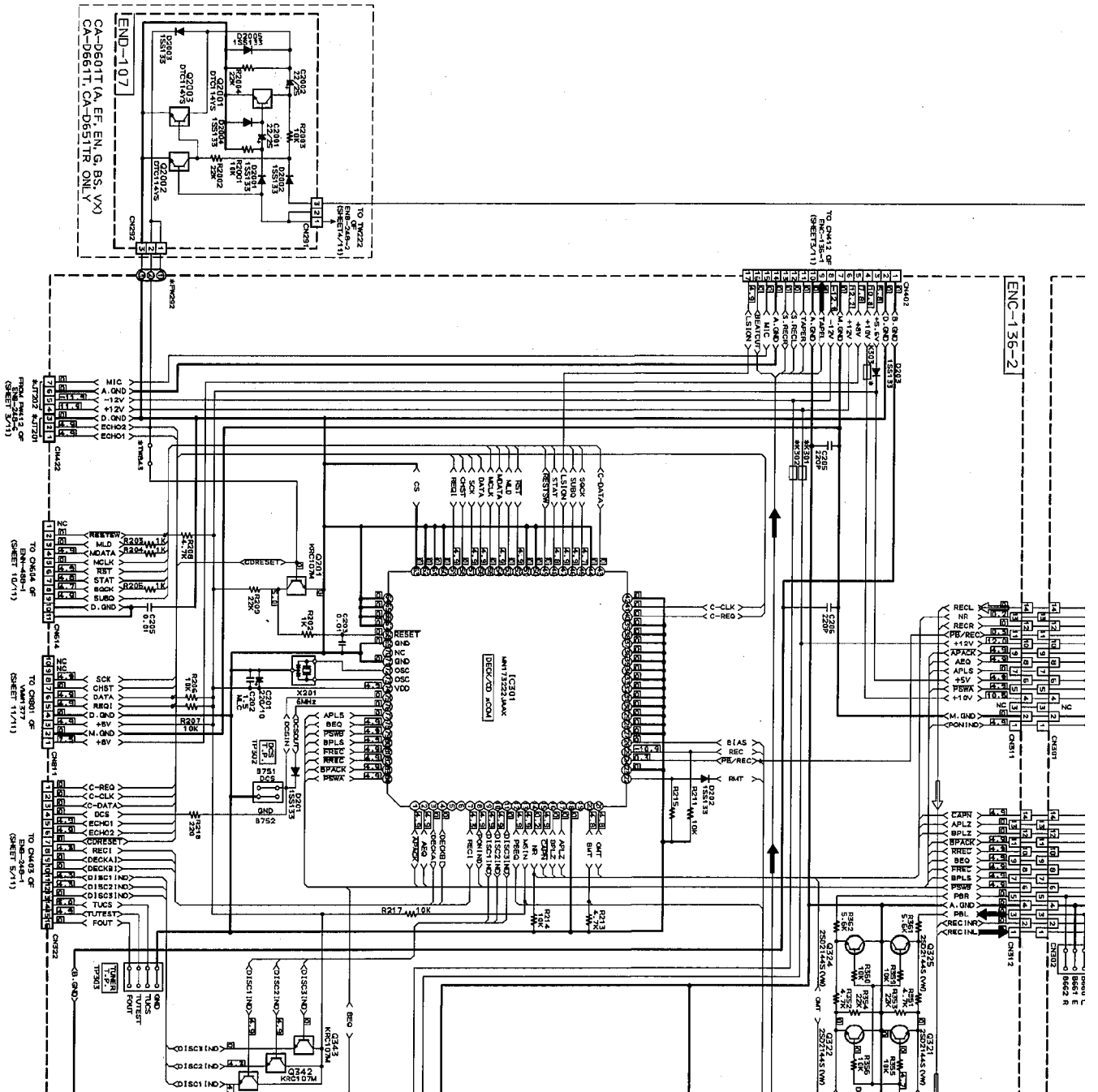

Deck Section

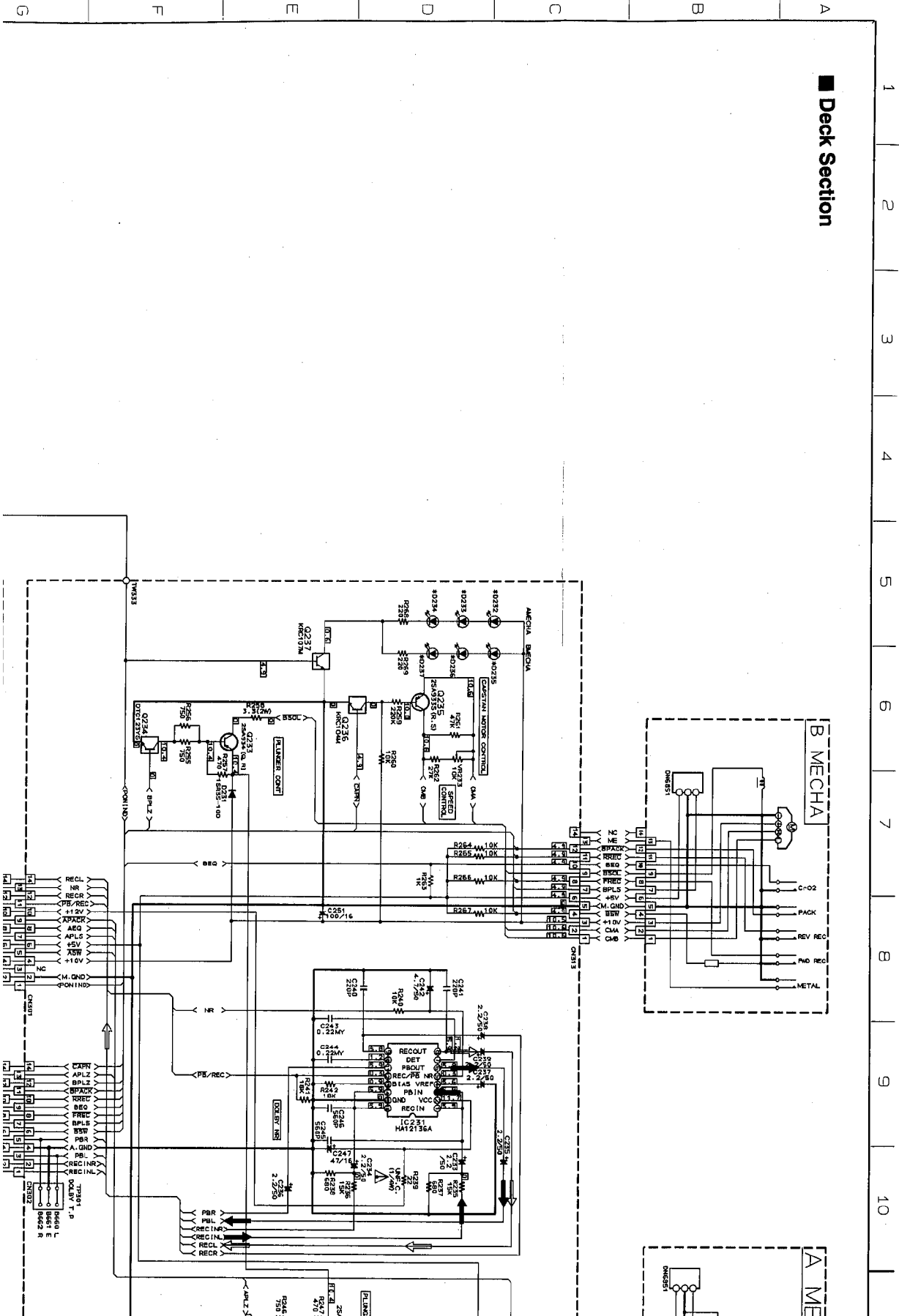









P1-69-a

P1-69-b

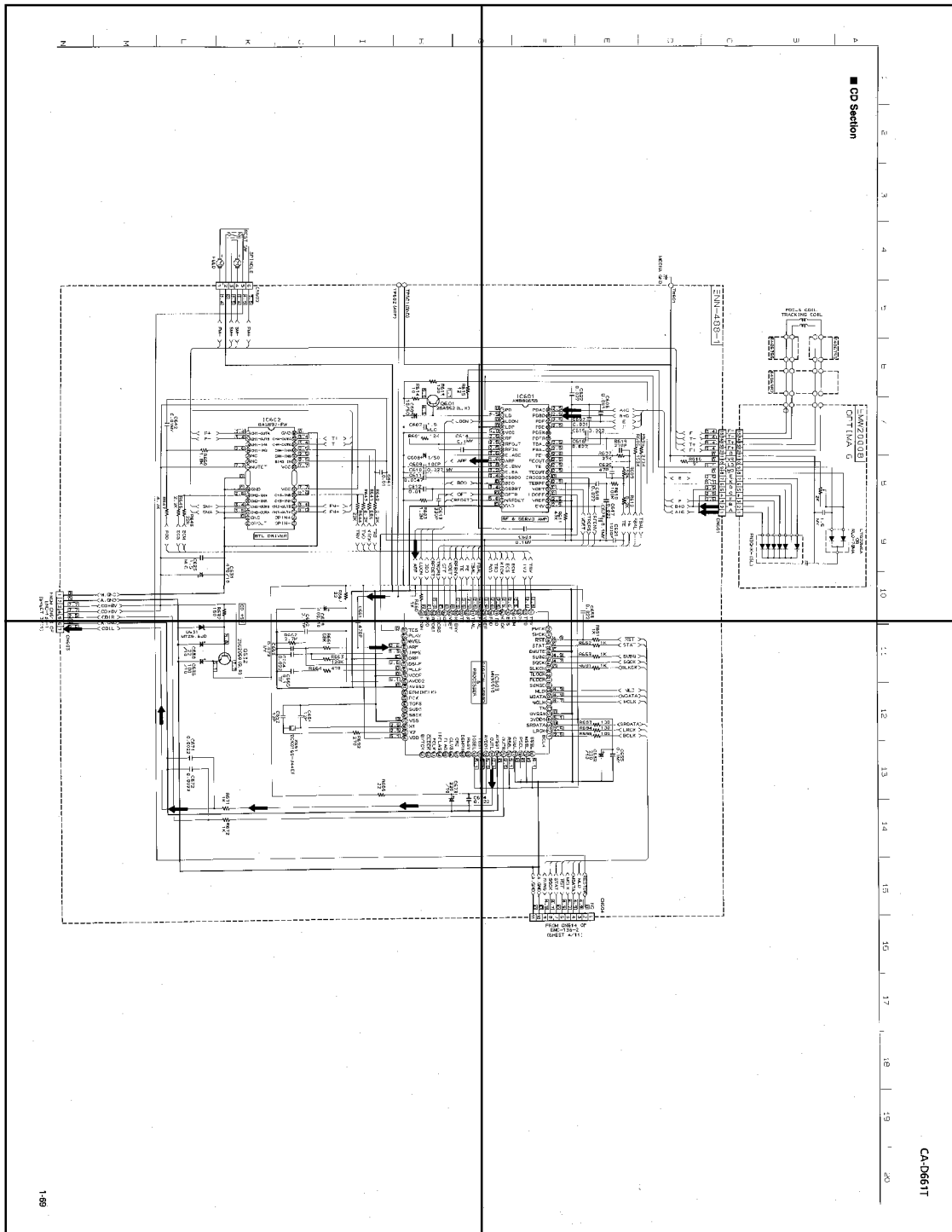

P1-69-c

P1-69-d

G I I C X L M Z

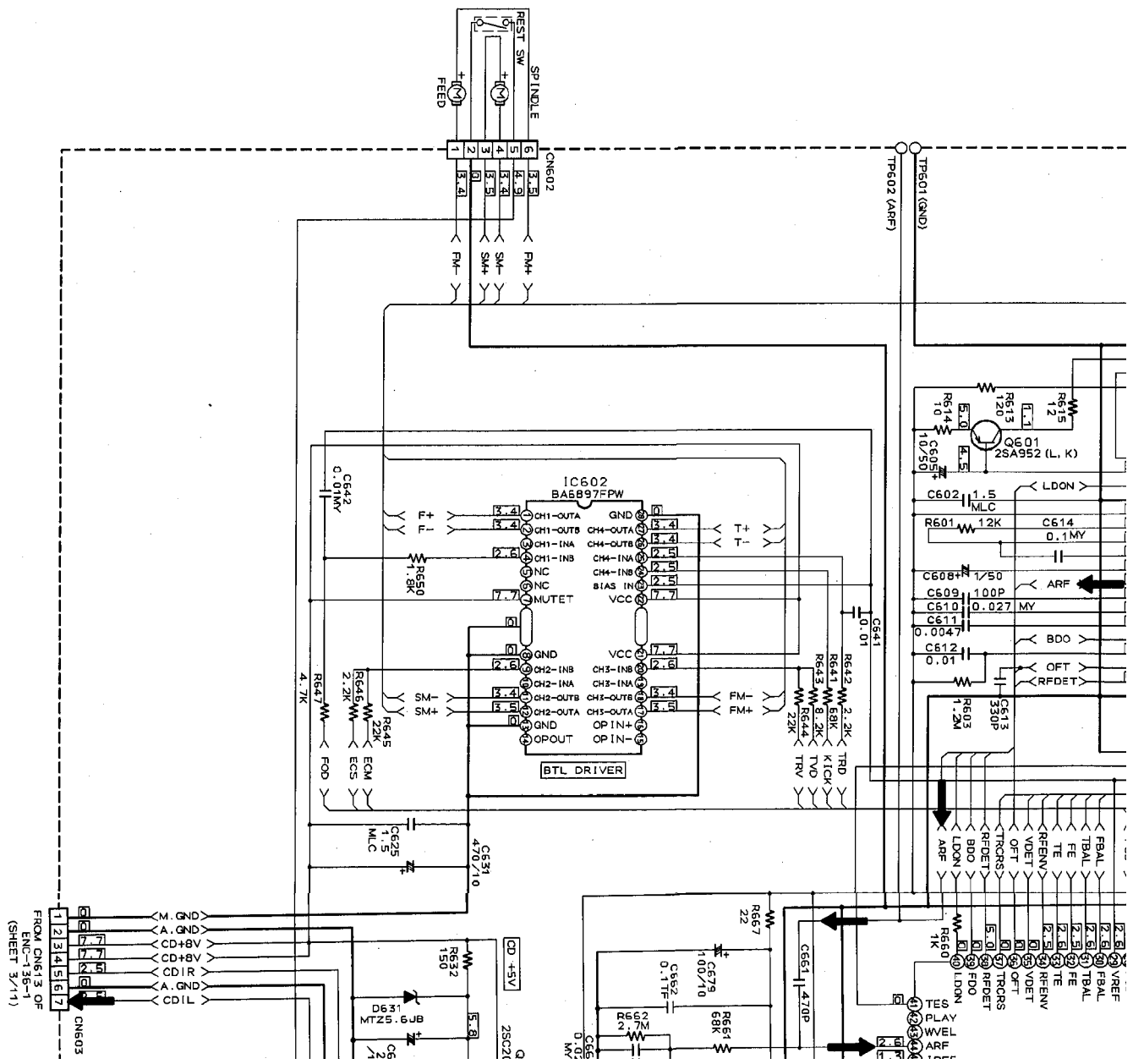

1 2 3 4 5 6 7 8 9 10 1

CD Section

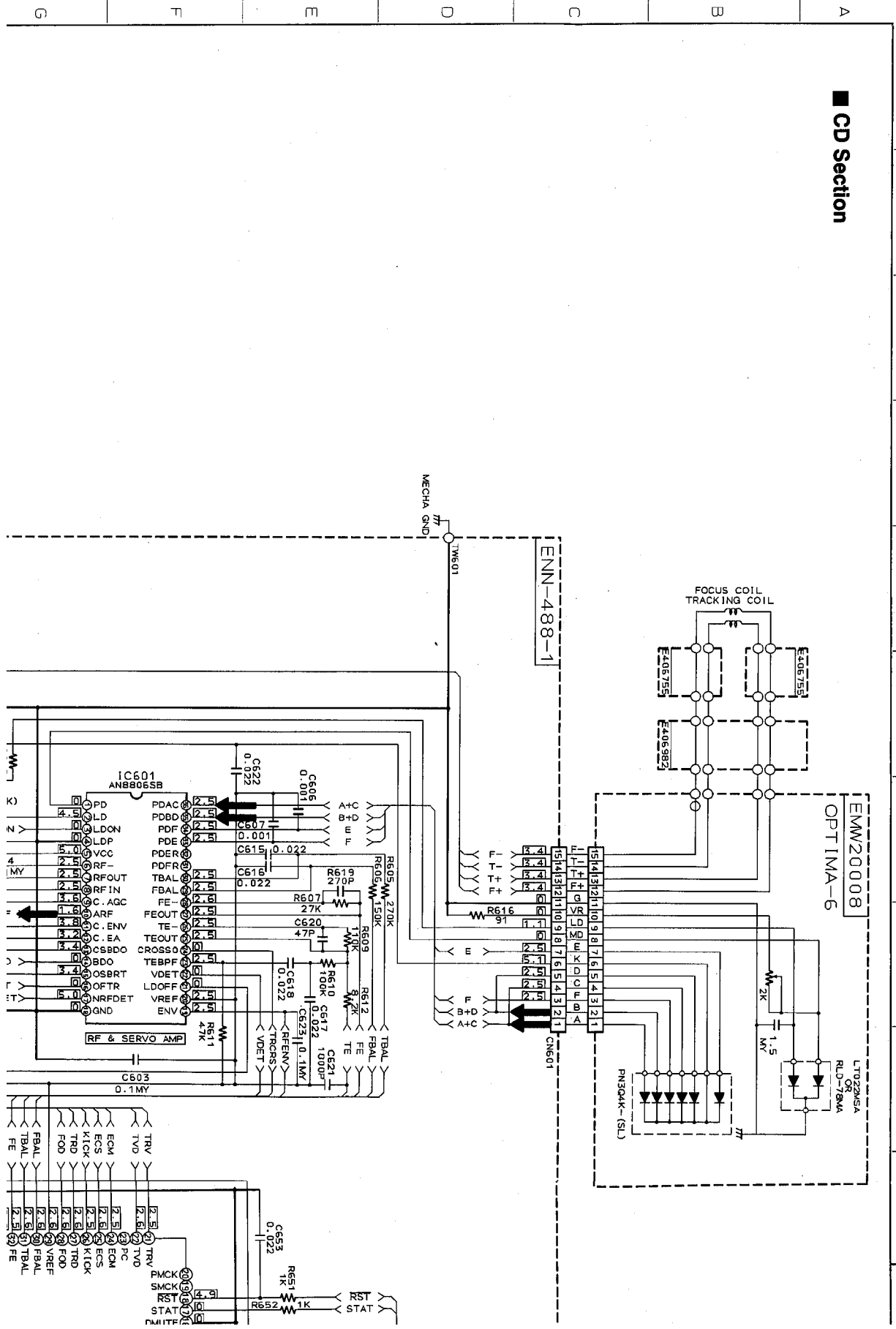

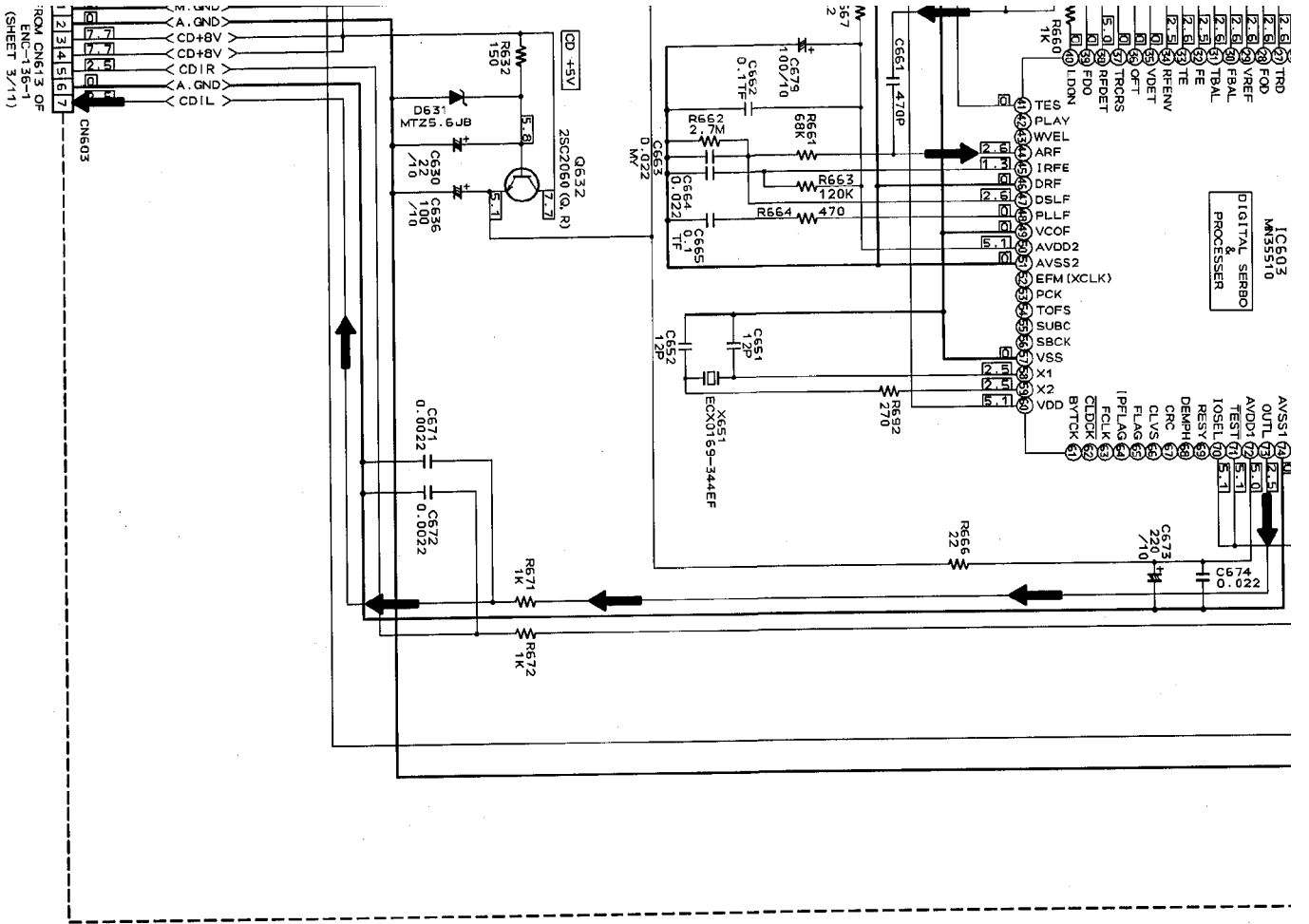

CA-D661T

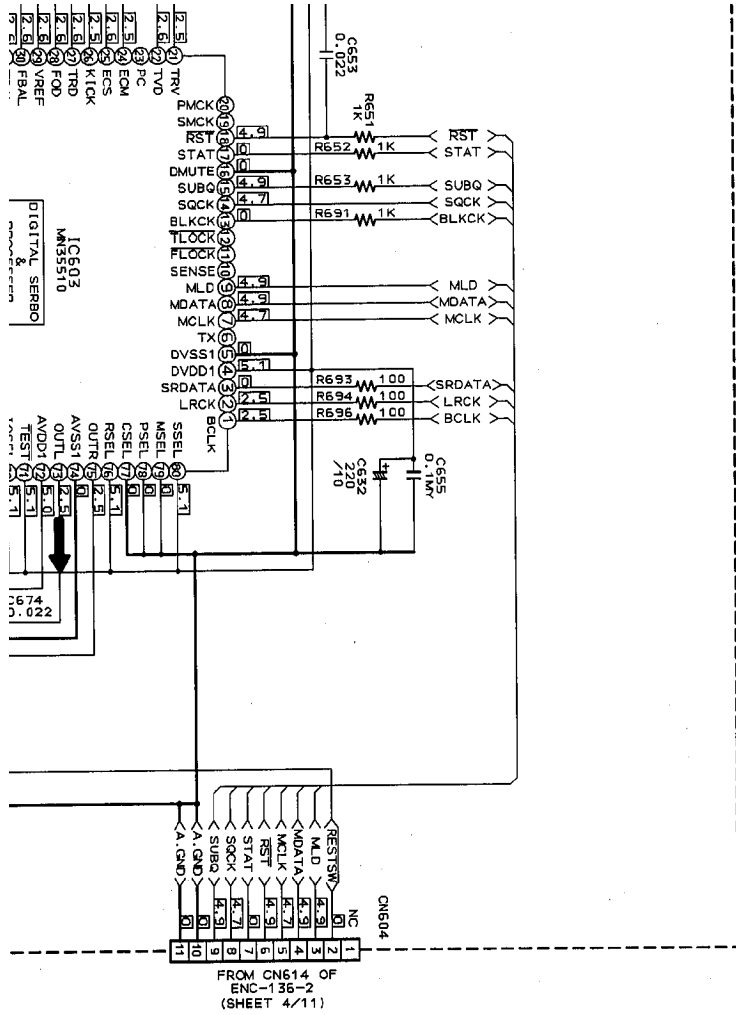



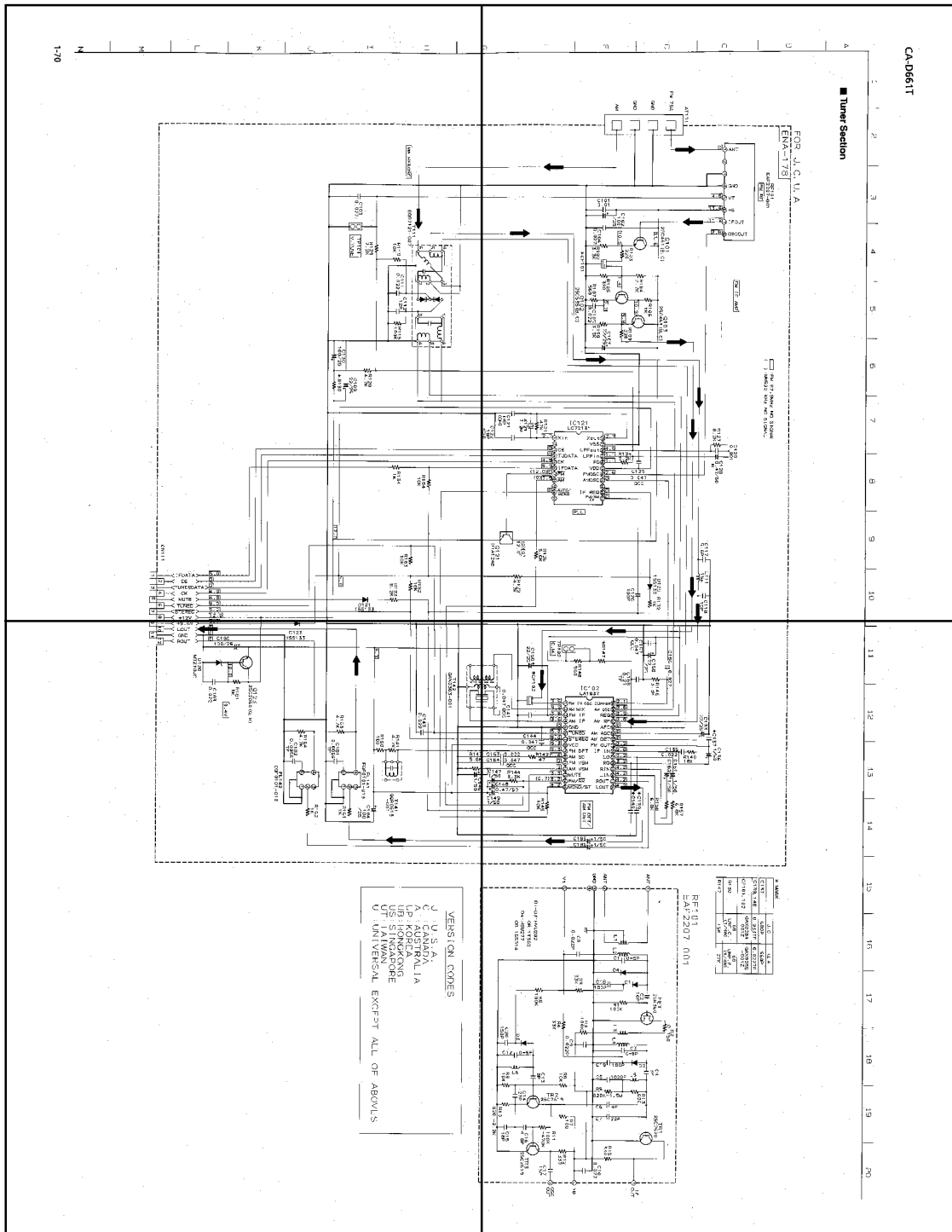

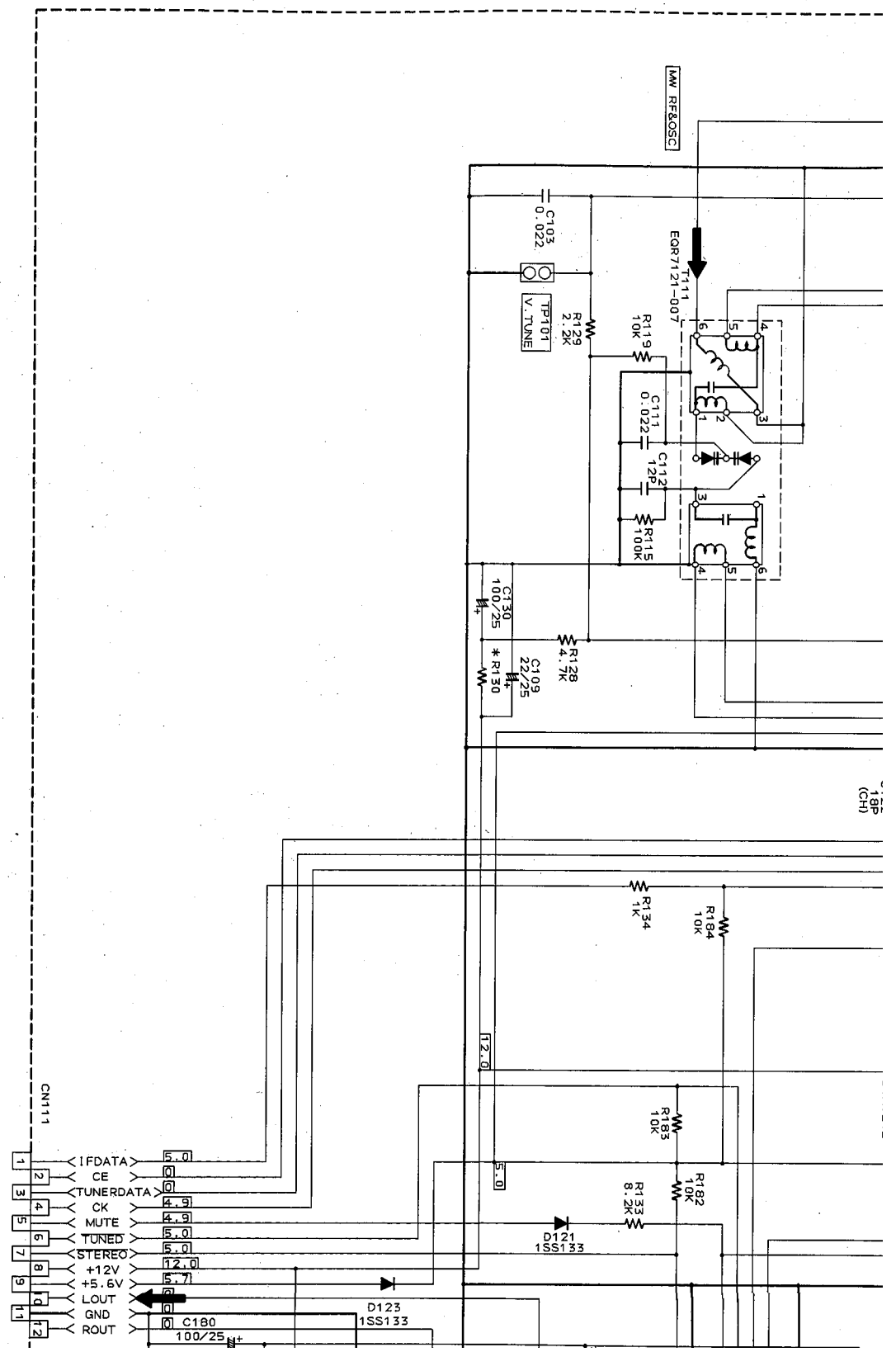





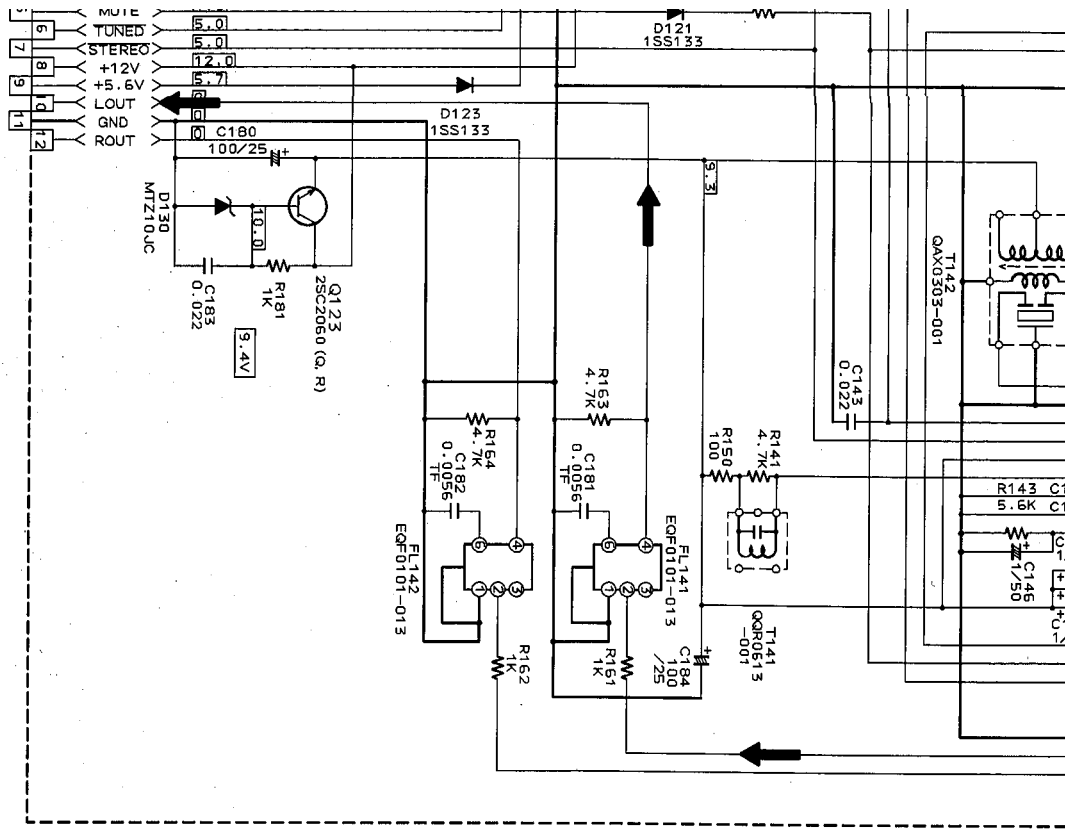

VERSION CODES

J : U.S.A.  
 C : CANADA  
 A : AUSTRALIA  
 UP : KOREA  
 UB : HONGKONG  
 US : SINGAPORE  
 UT : TAIWAN  
 U : UNIVERSAL EXCEPT ALL OF ABOVE

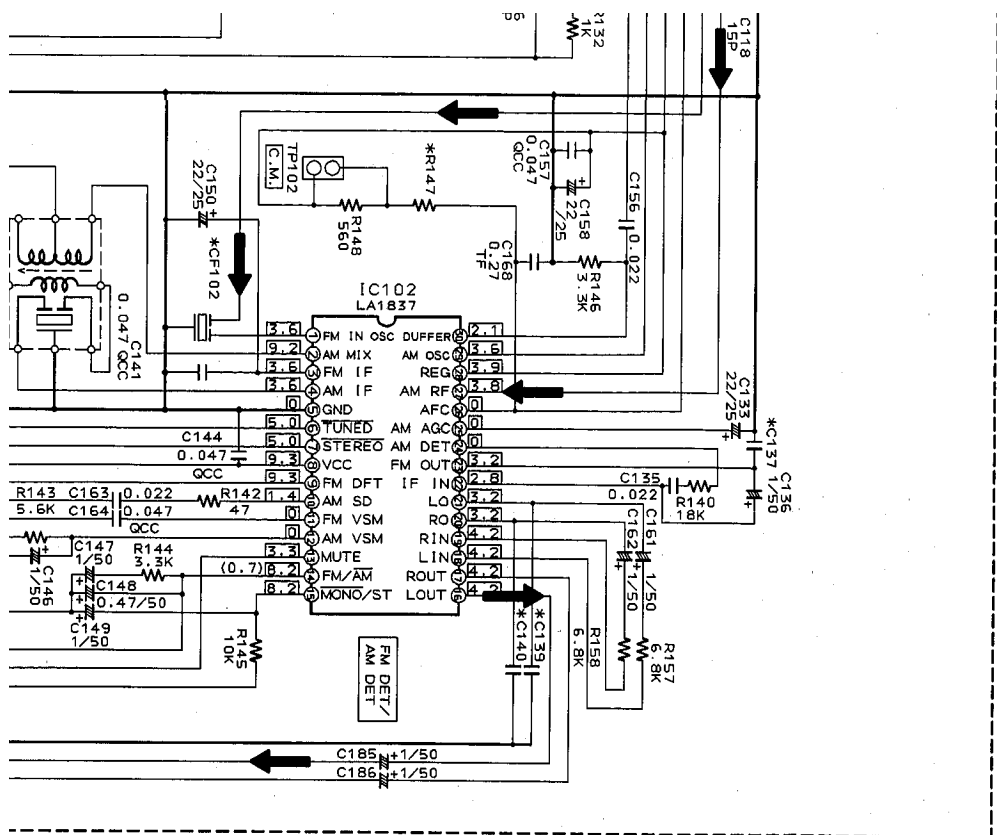

\* MARK

	J.C	U.A
C137	680P	5G0P
C139, 140	0.033TF	0.022TF
CF101, 102	0AX0284 -001Z	0AX0285 -001Z
R130	58 UNF.C. (1/4W)	58 UNF.F. (1/4W)
R147	15K	27K

RF101  
EAF2207-001

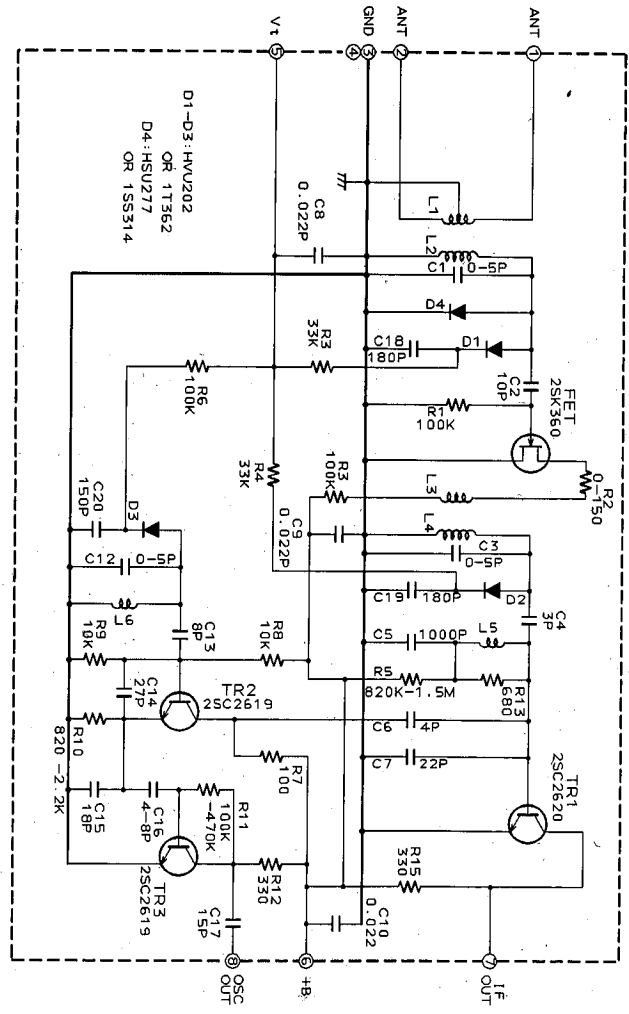



P1-71-a

P1-71-b

P1-71-c

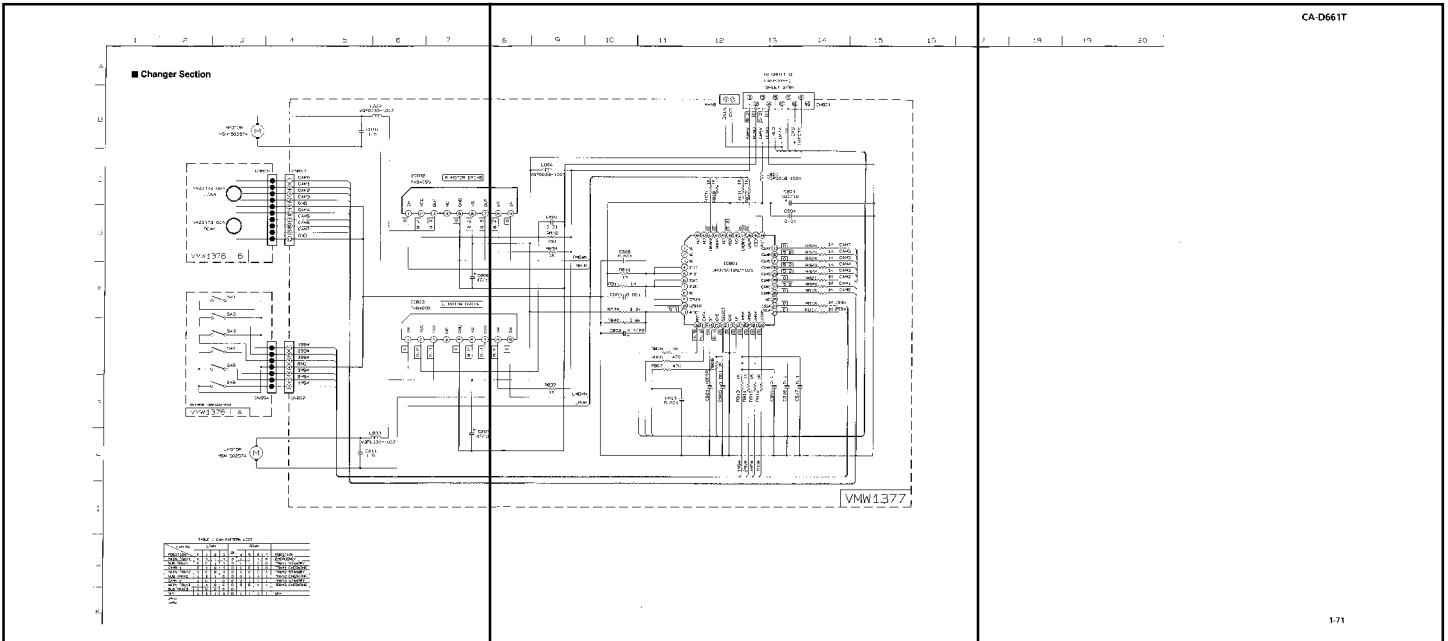

CA-D661T

# Changer Section

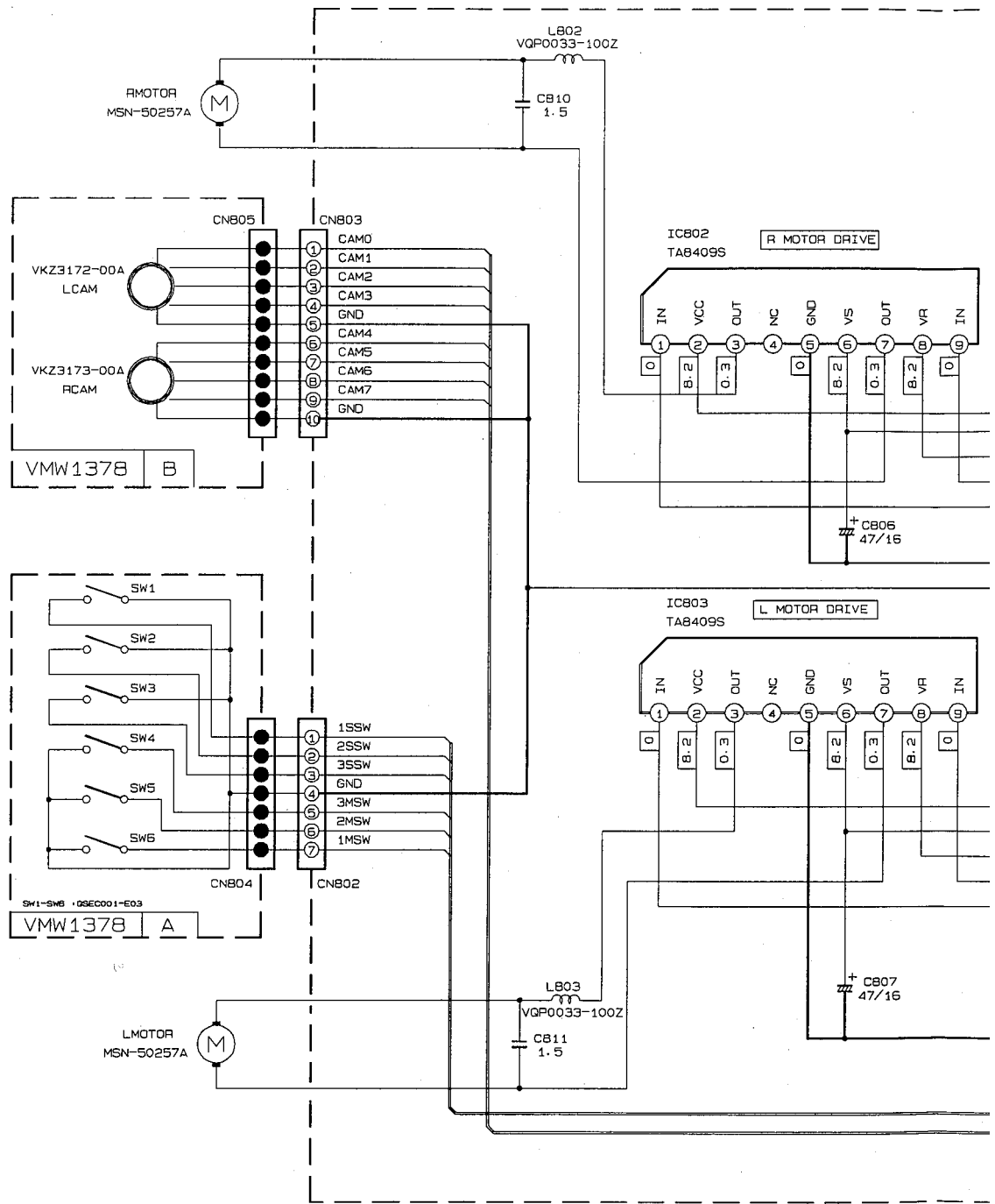
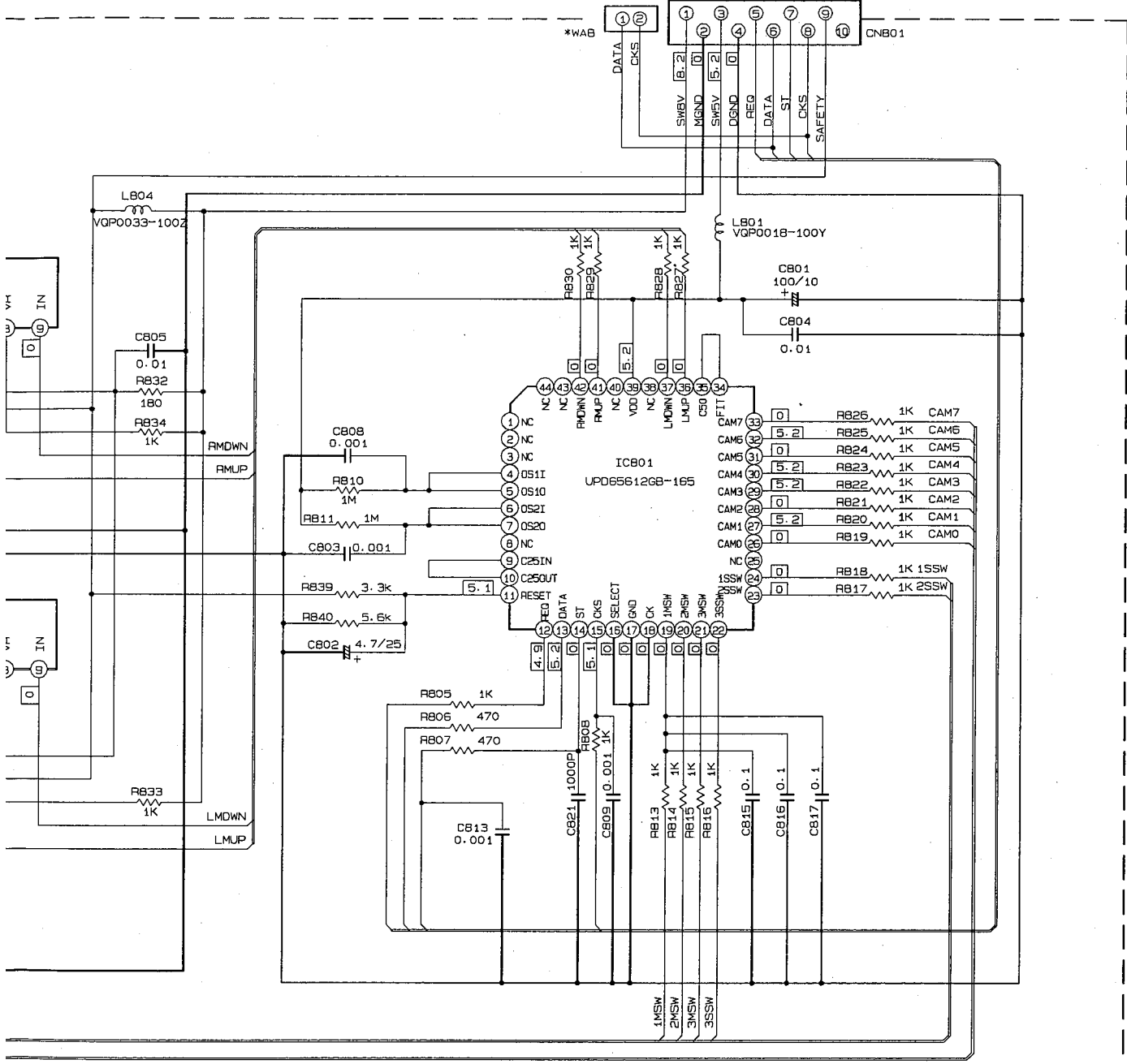

TABLE 1 CAM PATTERN LIST

CAM NO	LCAM				OR	FCAM				POSITION
	0	1	2	3		4	5	6	7	
MAIN TRAY1	0	1	1	1	0	1	1	1	0	EMERGENCY
SUB TRAY1	0	0	1	1	0	1	1	0	0	TRAY1 STANDBY
CAMR 1	0	1	0	1	0	1	0	1	0	TRAY1 CHECKING
MAIN TRAY2	1	0	0	1	0	1	0	0	1	TRAY2 STANDBY
SUB TRAY2	1	1	1	0	0	1	1	1	1	TRAY2 CHECKING
CAMR 2	1	0	1	0	0	0	1	0	1	TRAY3 STANDBY
MAIN TRAY3	1	1	0	0	0	0	0	1	1	TRAY3 CHECKING
SUB TRAY3	1	0	0	0	0					
OFF	1	1	1	1	0	1	1	1	1	OFF

0=0V  
1=5V

TO CNB11 OF  
FMH-005-1  
(SHEET 2/8)



VMW1377

16	17	18	19	20
----	----	----	----	----

7





# Printed Circuit Boards

## ■ Power Supply & Amp Board (ENH-302)

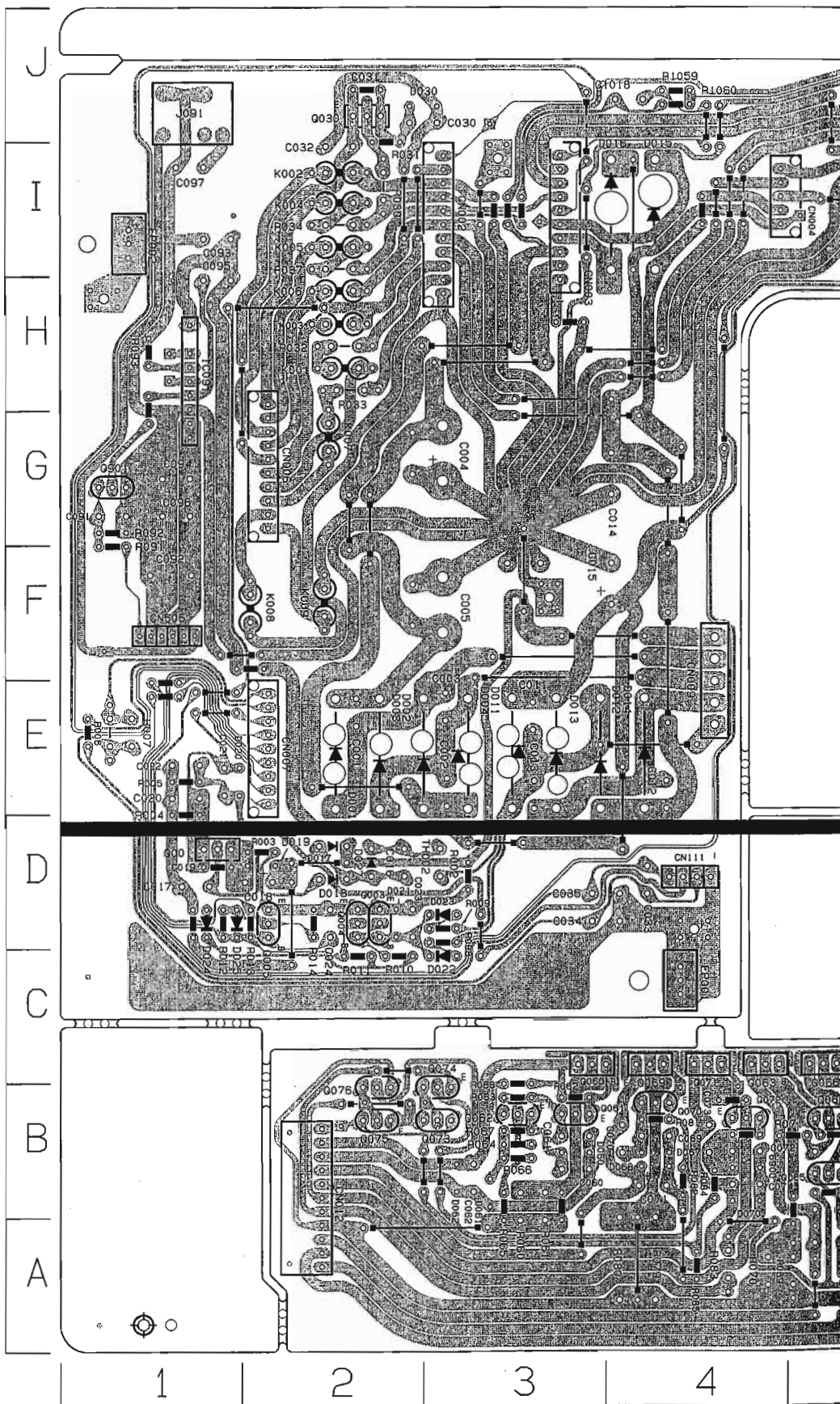



Location List (ENH-302)

Symbol	X	Y	Symbol	X	Y	Symbol	X	Y	Symbol	X	Y	Symbol	X	Y	Symbol	X	Y
C001	2	E	C716	7	A	D022	3	C	Q060	3	C	R063	3	B	R735	6	B
C002	3	E	C717	7	A	D023	3	D	Q061	3	B	R064	3	B	R736	6	B
C003	3	E	C718	7	A	D024	1	D	Q062	3	B	R065	3	A	R737	6	B
C004	3	G	C721	6	D	D025	1	D	Q063	4	C	R066	3	B	R738	6	B
C004A	2	F	C722	6	D	D027	2	D	Q064	5	B	R067	3	B	R739	6	B
C005	3	F	C726	8	A	D030	3	J	Q065	5	B	R068	3	B	R740	6	B
C005A	2	G	C729	8	B	D040	5	I	Q066	5	C	R069	5	A	R741	10	F
C011	3	E	C751	9	B	D041	6	I	Q067	5	B	R069A	5	A	R742	10	F
C012	4	E	C752	9	B	D043	6	I	Q068	5	B	R070	4	A	R743	10	I
C013	3	E	C753	9	B	D060	3	B	Q069	4	C	R070A	4	A	R744	10	I
C014	4	G	C754	8	B	D061	3	B	Q070	4	B	R071	5	B	R745	10	I
C015	4	F	C755	9	C	D062	3	B	Q071	4	C	R072	5	B	R746	9	I
C016	2	D	C756	8	C	D063	5	A	Q072	4	B	R073	5	B	R747	9	I
C017	1	D	C757	9	C	D064	5	A	Q073	2	B	R074	5	A	R748	10	I
C018	2	D	C758	8	C	D065	5	B	Q074	2	B	R074A	5	A	R749	9	G
C019	1	D	C770	9	H	D066	5	A	Q075	2	B	R075	5	A	R750	9	H
C020	1	E	C781	9	E	D067	4	B	Q076	2	B	R076	5	C	R751	9	B
C021	1	E	C782	9	E	D068	4	B	Q1057	8	B	R077	5	B	R752	9	B
C022	1	E	C783	10	F	D069	4	B	Q701	6	A	R078	5	B	R753	9	B
C023	2	D	C784	10	G	D070	4	B	Q702	7	A	R079	4	A	R754	8	B
C024	2	D	C785	10	G	D1060	5	I	Q726	8	A	R080	4	A	R755	9	B
C030	2	J	C786	10	H	D703	9	C	Q727	8	B	R081	4	B	R756	8	B
C031	2	J	C787	10	F	D704	8	C	Q728	8	A	R082	4	B	R757	9	B
C032	2	I	C788	10	G	D719	6	A	Q733	6	A	R083	4	A	R758	8	B
C033	4	D	C789	10	F	D720	7	B	Q734	6	A	R084	4	B	R759	9	B
C034	3	D	C790	10	G	D728	8	A	Q735	6	A	R085	4	A	R760	8	B
C035	3	D	C791	10	F	D751	9	A	Q736	6	A	R091	1	F	R761	9	B
C060	3	B	C792	10	G	D752	9	A	Q737	6	B	R092	1	G	R762	8	B
C061	3	B	C793	10	I	D753	9	B	Q751	9	B	R093	1	H	R763	9	C
C062	3	B	C794	10	I	D754	9	B	Q752	8	B	R1056	8	C	R764	8	C
C063	5	B	C795	10	I	D755	9	B	Q753	9	B	R1057	8	C	R765	9	B
C064	5	B	C796	9	I	D756	8	B	Q754	8	B	R1058	9	A	R766	8	B
C065	5	A	C797	10	I	D757	9	C	Q755	9	C	R1059	4	J	R767	9	C
C066	5	B	C798	10	I	D758	8	C	Q756	8	C	R1060	4	J	R768	8	C
C067	5	B	C799	8	E	D759	9	C	Q757	9	D	R1073	6	I	R769	9	C
C068	5	A	CH001	7	I	D760	8	C	Q758	8	D	R1074	6	I	R770	9	C
C069	4	B	CH002	3	I	D789	10	I	Q781	10	I	R1091	8	J	R771	9	B
C070	4	B	CH003	5	I	D790	9	I	Q782	9	I	R1092	7	I	R772	9	B
C071	4	B	CH004	7	J	F001	5	F	Q901	1	G	R1093	8	I	R773	8	B
C072	4	B	CN002	3	I	F002	6	H	R001	7	E	R701	7	C	R774	8	A
C073	4	B	CN003	3	H	F003	5	E	R002	3	D	R702	8	C	R775	7	C
C074	4	B	CN004	4	I	F101	7	H	R003	2	D	R703	7	C	R776	8	C
C091	1	G	CN005	6	I	F102	7	H	R004	1	D	R704	8	C	R777	8	A
C092	1	F	CN005B	6	I	FW101	7	E	R005	1	E	R705	7	C	R778	8	A
C093	1	I	CN006	2	H	FW401	6	D	R006	1	E	R706	8	C	R781	9	G
C094	1	G	CN007	2	E	IC091	1	G	R007	1	E	R707	7	C	R782	9	H
C095	1	H	CN009	4	F	IC701	7	D	R008	3	D	R708	8	C	R783	10	G
C096	1	G	CN012	2	B	IC702	8	D	R009	3	D	R709	6	B	R784	10	H
C097	1	I	CN013	9	C	IC781	9	F	R010	2	C	R710	7	B	R785	10	G
C101	6	D	CN014	10	J	IC782	9	G	R011	2	C	R711	6	B	R786	10	H
C1017	8	C	CN019	7	E	J091	1	J	R012	1	D	R712	7	B	R787	10	F
C1018	4	J	CN111	4	D	K001	2	H	R013	2	D	R713	6	A	R788	10	G
C102	6	D	CN505	1	F	K002	2	I	R014	2	D	R714	7	A	R789	10	H
C103	7	B	CN703	6	D	K003	2	H	R030	2	I	R715	7	A	R790	9	H
C1061	7	C	CN704	9	E	K004	2	I	R031	2	I	R716	7	A	R791	10	H
C1062	8	C	CN915	6	A	K005	2	I	R032	2	H	R717	6	B	R792	9	H
C1073	5	I	D001	2	E	K006	2	H	R033	2	H	R718	7	B	R793	10	H
C1074	5	I	D002	2	E	K007	2	G	R034	2	I	R719	6	A	R794	9	H
C703	7	C	D003	2	E	K008	2	F	R037	2	I	R720	7	A	R795	10	I
C704	8	C	D004	3	E	K009	2	F	R040	6	I	R721	6	A	R796	9	I
C705	7	C	D011	3	E	L701	7	B	R041	5	I	R722	7	A	R797	10	H
C706	8	C	D012	3	E	L702	7	B	R042	5	I	R723	7	B	R798	9	H
C707	7	C	D013	3	E	L781	10	H	R043	6	I	R724	7	B	S001	7	I
C708	8	C	D014	4	E	L782	9	H	R044	6	I	R725	9	A	TB001	6	G
C709	7	C	D015	4	I	Q001	1	D	R045	5	I	R726	9	A	TB002	5	F
C710	8	C	D016	4	I	Q003	2	D	R052A	5	A	R727	8	B	TH002	3	D
C711	7	D	D017	2	D	Q004	2	D	R060	3	A	R728	8	A			
C712	8	D	D018	2	D	Q005	2	D	R060A	3	B	R729	8	B			
C713	7	A	D019	2	D	Q030	2	J	R061	3	A	R730	8	A			
C714	7	A	D020	1	E	Q040	5	I	R061A	3	B	R733	6	B			
C715	6	A	D021	2	D	Q041	6	I	R062	3	B	R734	6	B			



■ Front & Control Board (ENB248)

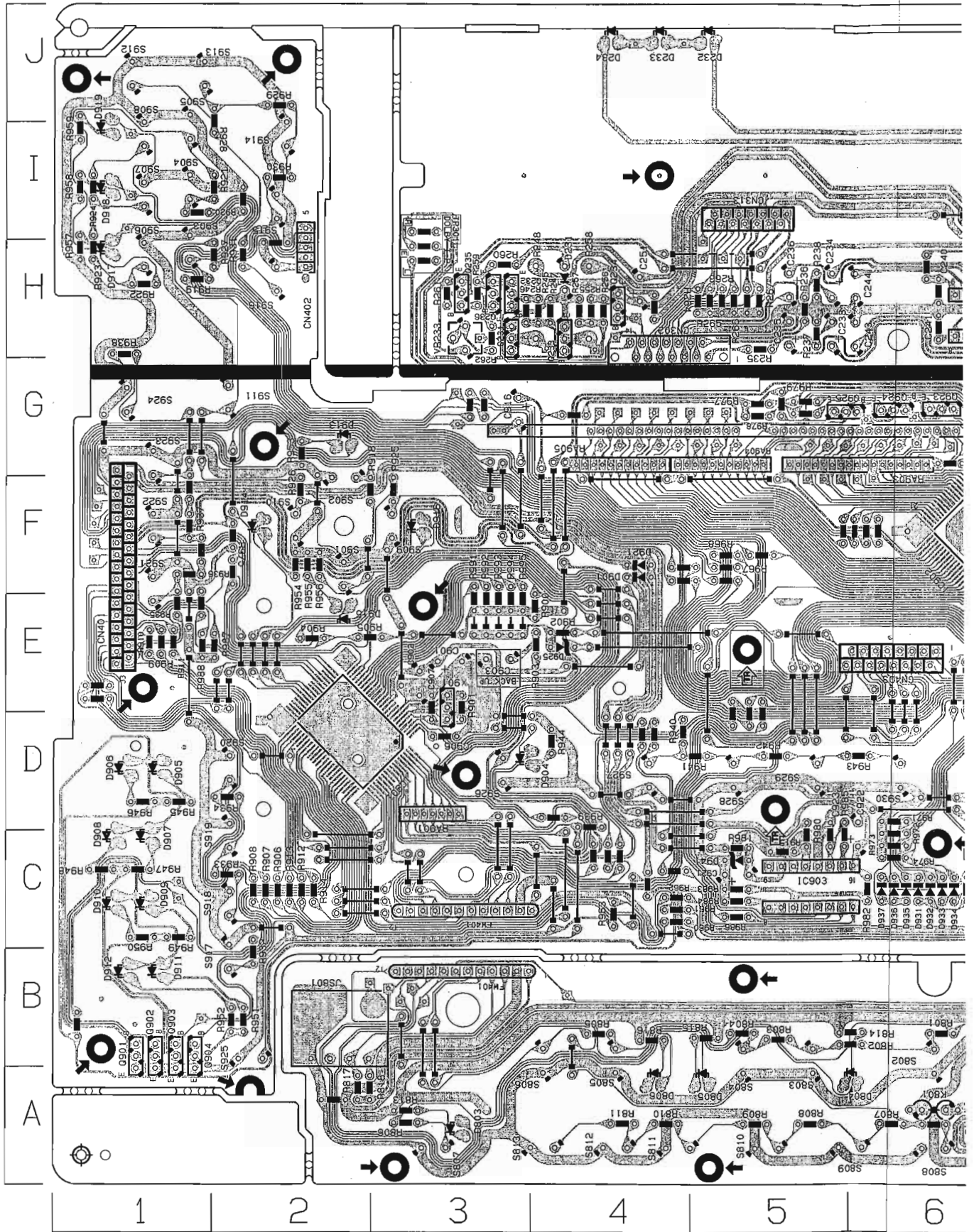









■ Source Select & SEA Board (ENC136)

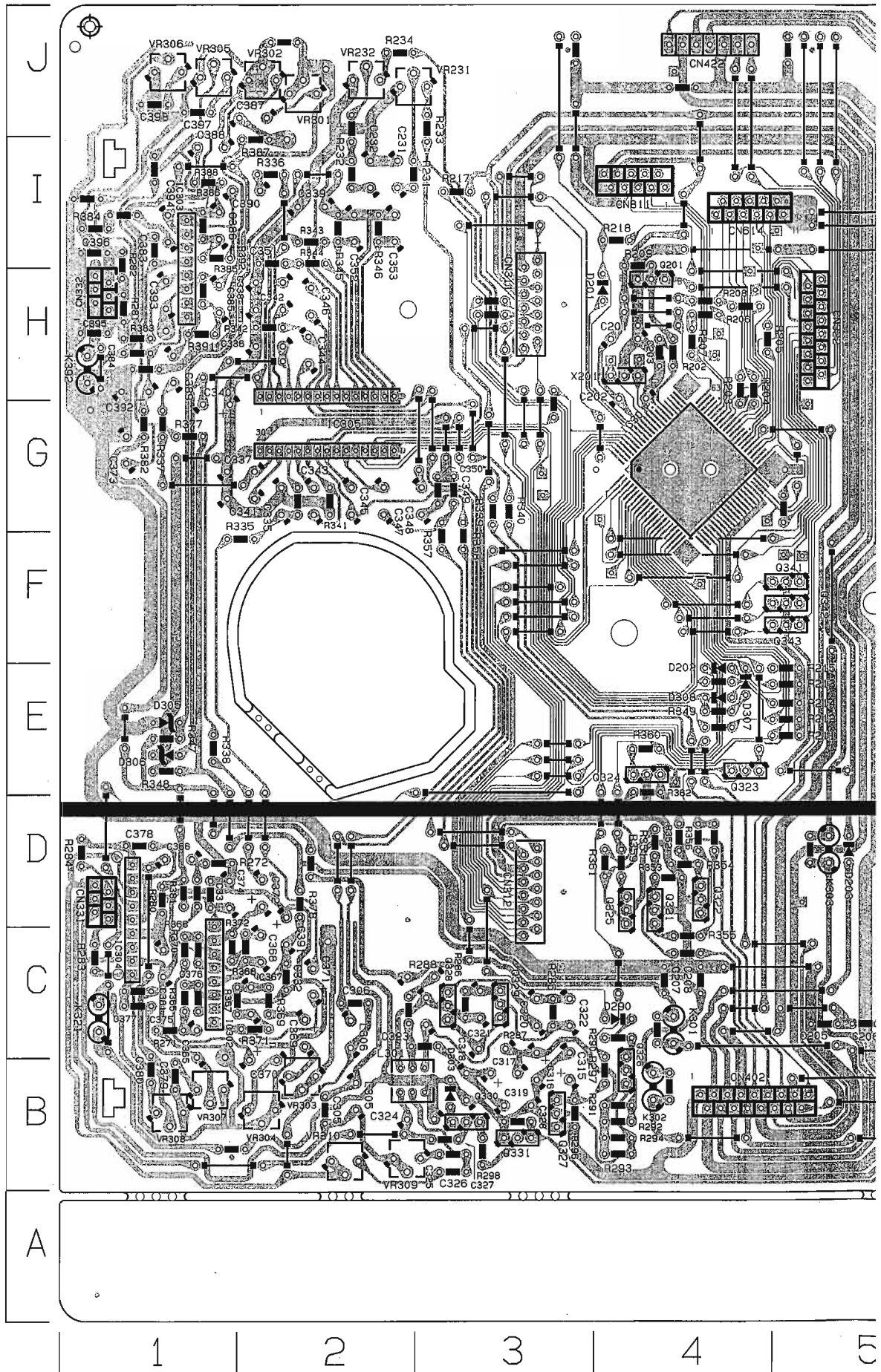

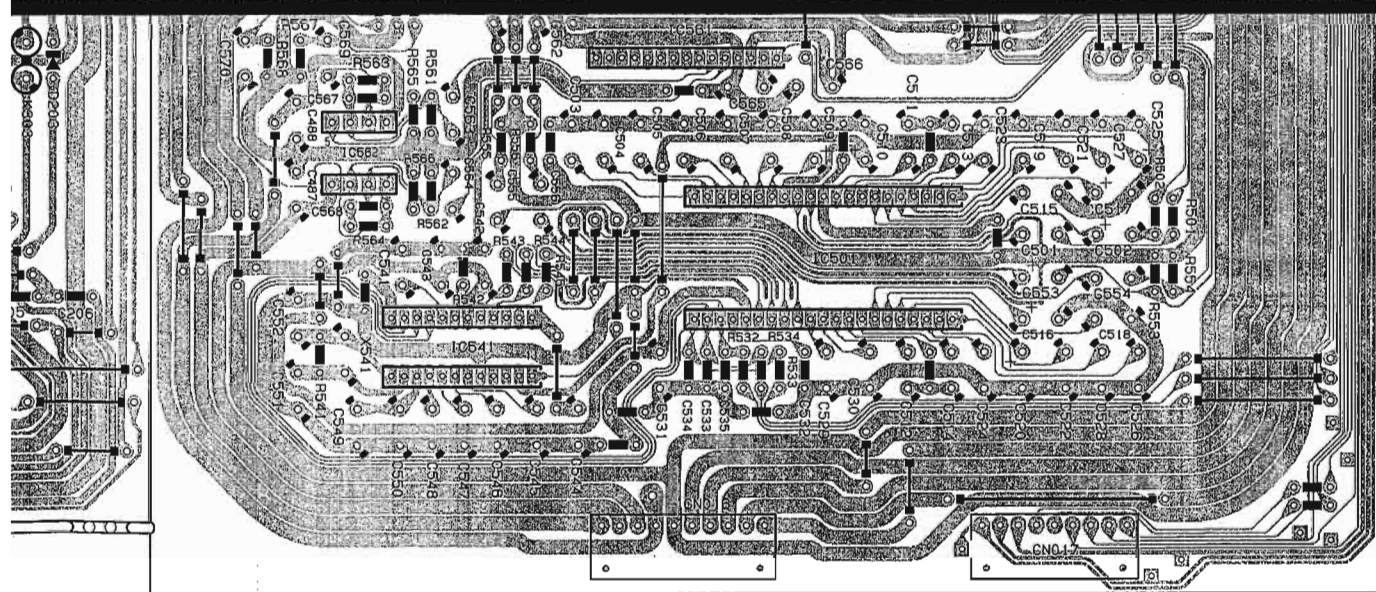
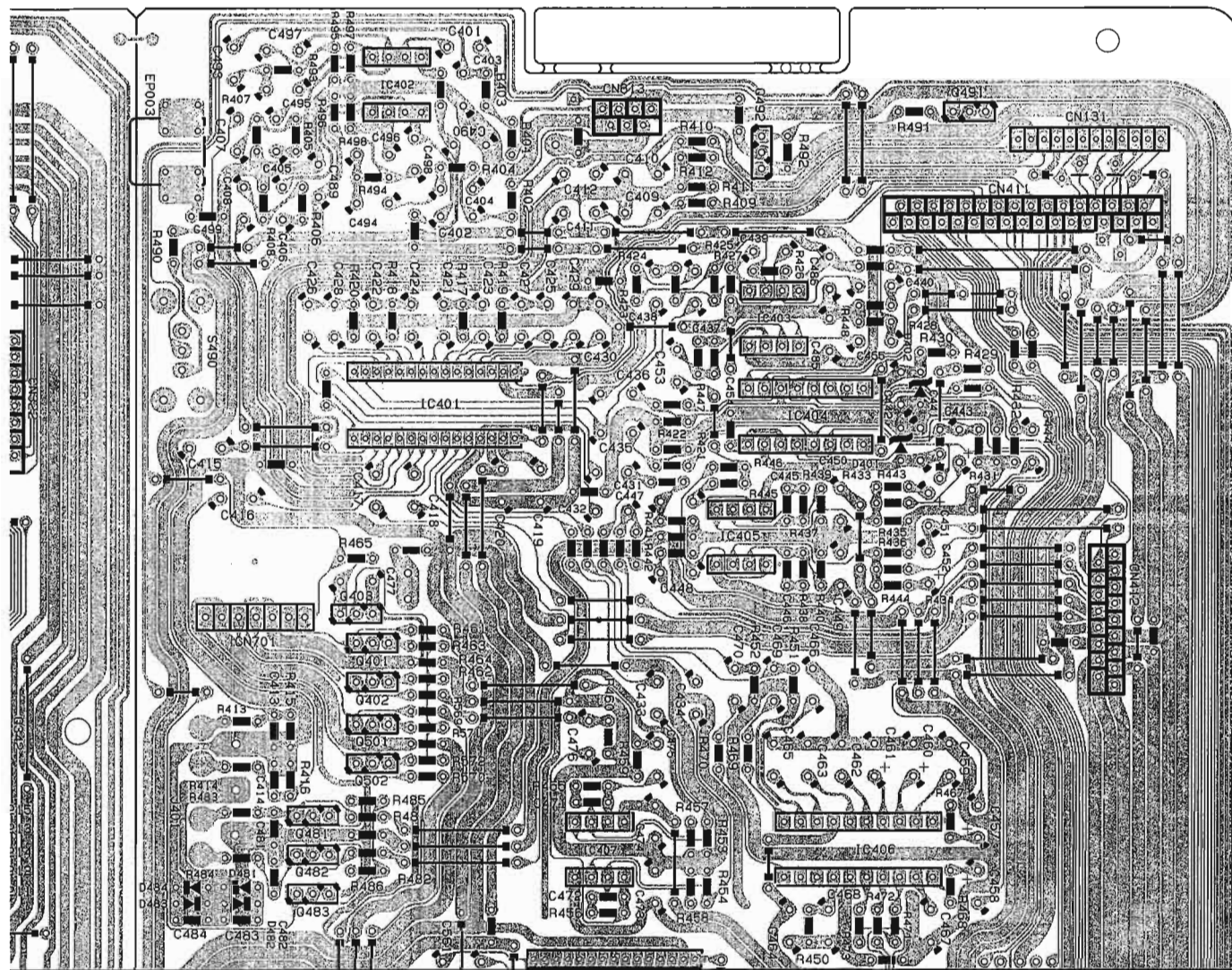

5 | 6 | 7 | 8 | 9 | 10

Location List (ENC-136)

Symbol	X	Y	Symbol	X	Y	Symbol	X	Y	Symbol	X	Y	Symbol	X	Y	Symbol	X	Y	Symbol	X	Y
C201	4	H	C398	1	J	C482	6	E	CN017	9	A	Q502	7	F	R383	1	H	R473	9	E
C202	4	H	C401	7	J	C483	6	E	CN131	9	J	R202	4	H	R384	1	I	R481	7	E
C203	4	H	C402	7	I	C484	6	E	CN311	3	I	R203	4	H	R385	1	H	R482	7	E
C205	5	C	C403	7	J	C485	9	I	CN312	3	D	R204	4	H	R386	1	I	R483	6	E
C206	5	C	C404	7	I	C486	9	I	CN322	5	H	R205	4	H	R387	2	I	R484	6	E
C207	4	C	C405	6	J	C487	6	C	CN331	1	D	R206	4	H	R388	1	I	R485	7	F
C208	4	C	C406	6	I	C488	6	D	CN332	1	H	R207	4	H	R391	1	H	R486	7	E
C231	2	I	C407	6	J	C489	6	J	CN402	4	B	R208	4	H	R392	1	I	R490	6	I
C232	2	I	C408	6	I	C490	7	J	CN411	10	I	R209	4	I	R401	7	J	R491	9	J
C305	2	B	C409	8	I	C493	6	J	CN412	10	G	R211	4	E	R402	7	I	R492	8	I
C306	2	C	C410	8	I	C494	7	I	CN422	4	J	R212	4	E	R403	7	J	R493	6	J
C315	3	B	C411	7	I	C495	6	J	CN613	8	J	R213	4	E	R404	7	I	R494	7	I
C316	3	C	C412	7	I	C496	7	J	CN614	5	I	R214	4	E	R405	6	J	R495	6	J
C317	3	B	C413	6	F	C497	6	J	CN701	6	G	R215	4	E	R406	6	I	R496	6	J
C318	3	B	C414	6	F	C498	7	J	CN811	4	I	R217	3	I	R407	6	J	R497	6	J
C319	3	B	C415	6	H	C499	6	I	D201	4	H	R218	4	I	R408	6	I	R498	6	J
C320	3	C	C416	6	G	C501	9	C	D202	4	E	R231	2	I	R409	8	I	R501	10	C
C321	3	C	C417	6	H	C502	9	C	D203	5	D	R232	2	I	R410	8	J	R502	10	C
C322	3	C	C418	7	H	C503	7	D	D290	4	C	R233	3	I	R411	8	I	R532	8	B
C323	3	C	C419	7	H	C504	7	D	D303	3	B	R234	2	J	R412	8	J	R533	8	B
C324	2	B	C420	7	H	C505	7	D	D305	1	E	R271	1	C	R413	6	F	R534	8	B
C325	3	B	C421	7	H	C506	8	D	D306	1	E	R272	1	D	R414	6	F	R541	6	C
C326	3	B	C422	6	H	C507	8	D	D307	4	E	R280	1	D	R415	6	F	R542	7	C
C327	3	B	C423	7	H	C508	8	D	D308	4	E	R281	1	H	R416	6	F	R543	7	C
C328	3	B	C424	7	H	C509	8	D	D401	9	H	R282	1	H	R417	7	H	R544	7	C
C331	1	D	C425	7	H	C510	8	D	D402	9	H	R283	1	C	R418	7	H	R545	7	C
C332	2	C	C426	6	H	C511	9	D	D481	6	E	R284	1	D	R419	7	H	R553	10	C
C335	2	G	C427	7	H	C512	9	B	D482	6	E	R285	3	C	R420	6	H	R554	10	C
C336	2	H	C428	6	H	C513	9	D	D483	6	E	R286	3	C	R421	8	H	R555	7	D
C337	2	G	C429	7	H	C514	9	B	D484	6	E	R287	3	C	R422	8	H	R556	7	D
C338	2	H	C430	8	H	C515	9	C	IC301	4	G	R288	3	C	R423	8	I	R561	7	D
C339	2	I	C431	7	H	C516	9	C	IC302	1	C	R290	4	C	R424	8	I	R562	7	C
C340	1	G	C432	7	G	C517	9	C	IC303	1	I	R291	4	B	R425	8	I	R563	6	D
C341	1	G	C433	8	F	C518	9	C	IC304	1	D	R292	4	B	R426	8	I	R564	6	C
C342	2	H	C434	8	F	C519	9	D	IC305	2	H	R293	4	B	R427	8	I	R565	6	D
C343	2	G	C435	8	H	C520	9	B	IC401	7	H	R294	4	B	R428	9	I	R566	6	C
C344	2	H	C436	8	H	C521	9	D	IC402	7	J	R296	3	B	R429	9	H	R567	6	D
C345	2	G	C437	8	I	C522	9	B	IC403	8	H	R297	4	B	R430	9	H	R568	6	D
C346	2	H	C438	8	I	C523	9	D	IC404	9	H	R298	3	B	R431	9	H	R569	7	F
C347	2	G	C439	8	I	C524	9	B	IC405	8	G	R335	1	F	R432	9	H	R570	7	F
C348	3	G	C440	9	I	C525	9	D	IC406	9	E	R336	2	I	R433	9	G	R571	7	F
C349	3	G	C441	9	H	C526	9	B	IC407	8	E	R337	1	G	R434	9	G	R572	7	F
C350	3	G	C442	9	H	C527	9	D	IC501	8	C	R338	1	E	R435	9	G	S490	6	I
C351	2	I	C443	9	H	C528	9	B	IC541	6	C	R339	3	G	R436	9	G	X201	4	H
C352	2	I	C444	10	H	C529	8	B	IC561	8	D	R340	3	G	R437	8	G	X541	6	B
C353	2	I	C445	8	G	C530	8	B	IC562	6	C	R341	2	G	R438	8	G			
C365	1	C	C446	8	G	C531	7	B	K301	4	C	R342	2	H	R439	9	G			
C366	1	D	C447	8	G	C532	8	B	K302	4	B	R343	2	I	R440	9	G			
C367	2	C	C448	8	G	C533	8	B	K303	5	D	R344	2	I	R441	8	G			
C368	2	C	C449	9	G	C534	8	B	K321	1	C	R345	2	I	R442	8	G			
C369	2	C	C450	9	G	C535	8	B	K392	1	H	R346	2	I	R443	9	G			
C370	2	B	C451	9	G	C541	6	C	L301	2	B	R347	1	E	R444	9	G			
C371	2	C	C452	9	G	C542	7	C	L305	2	B	R348	1	E	R445	8	H			
C372	2	D	C453	8	H	C543	7	C	L306	2	C	R349	4	E	R446	8	H			
C373	1	G	C454	8	H	C544	7	B	Q201	4	H	R351	4	D	R447	8	H			
C374	1	D	C455	9	H	C545	7	B	Q321	4	D	R352	4	D	R448	9	I			
C375	1	C	C457	9	E	C546	7	B	Q322	4	D	R353	4	D	R450	8	E			
C376	1	C	C458	9	E	C547	7	B	Q323	4	E	R354	4	D	R451	8	F			
C377	1	C	C459	9	F	C548	7	B	Q324	4	E	R355	4	C	R452	8	F			
C378	1	D	C460	9	F	C549	6	B	Q325	4	D	R356	4	D	R453	8	E			
C379	1	B	C461	9	F	C550	6	B	Q326	4	C	R357	3	F	R454	8	E			
C380	1	C	C462	9	F	C551	6	B	Q327	3	B	R358	3	F	R455	7	F			
C381	1	C	C463	8	F	C552	6	C	Q328	3	C	R359	4	D	R456	7	E			
C383	1	I	C464	8	E	C553	9	C	Q329	3	C	R360	4	E	R457	8	E			
C384	1	H	C465	8	F	C554	9	C	Q330	3	B	R361	4	D	R458	8	E			
C385	1	H	C466	9	F	C555	7	C	Q331	3	B	R362	4	E	R459	8	F			
C386	1	I	C467	9	E	C556	7	C	Q341	4	F	R365	1	C	R460	8	F			
C387	2	J	C468	9	E	C561	7	D	Q342	4	F	R366	1	D	R461	7	G			
C388	1	I	C469	8	F	C562	7	D	Q343	4	F	R367	1	C	R462	7	F			
C389	1	H	C470	8	F	C563	7	D	Q401	7	G	R368	2	C	R463	7	F			
C390	1	I	C471	7	E	C564	7	C	Q402	7	F	R369	2	C	R464	7	F			
C391	2	D	C472	7	E	C565	8	D	Q403	6	G	R370	1	C	R465	6	G			
C392	1	H	C473	8	E	C566	8	D	Q481	6	E	R371	2	C	R467	9	E			
C393	1	H	C474	8	E	C567	6	D	Q482	6	E	R372	1	C	R468	9	E			
C394	1	I	C475	8	F	C568	6	C	Q483	6	E	R377	1	G	R469	8	F			
C395	1	H	C476	7	F	C569	6	D	Q491	9	J	R378	2	D	R470	8	F			
C396	1	I	C477	6	G	C570	6	D	Q492	8	I	R381	1	D	R471	9	E			
C397	1	J	C481	6	E	CN016	7	A	Q501	7	F	R382	1	G	R472	9	E			



■ Tuner Board (ENA178)

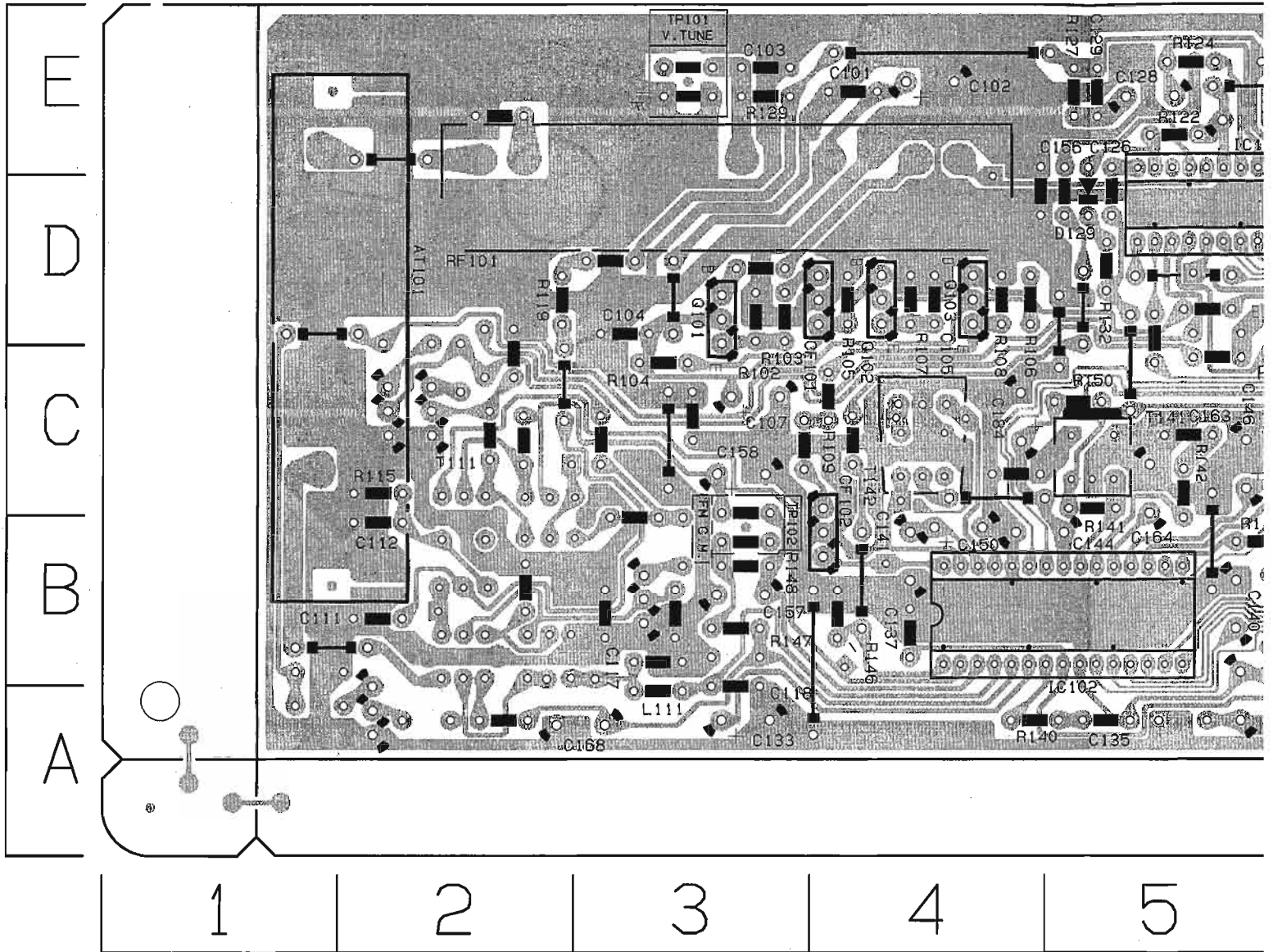

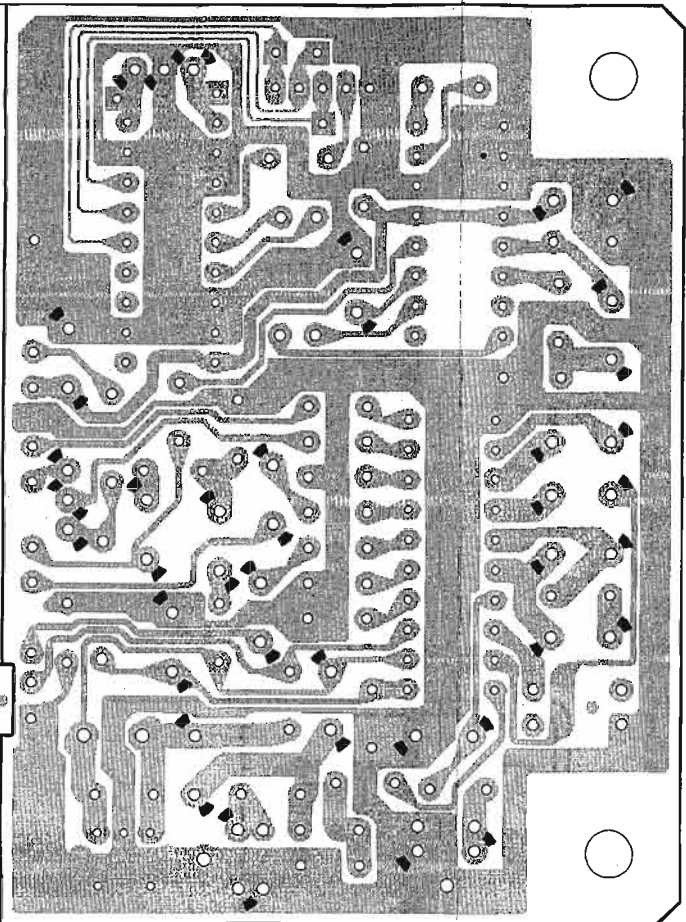
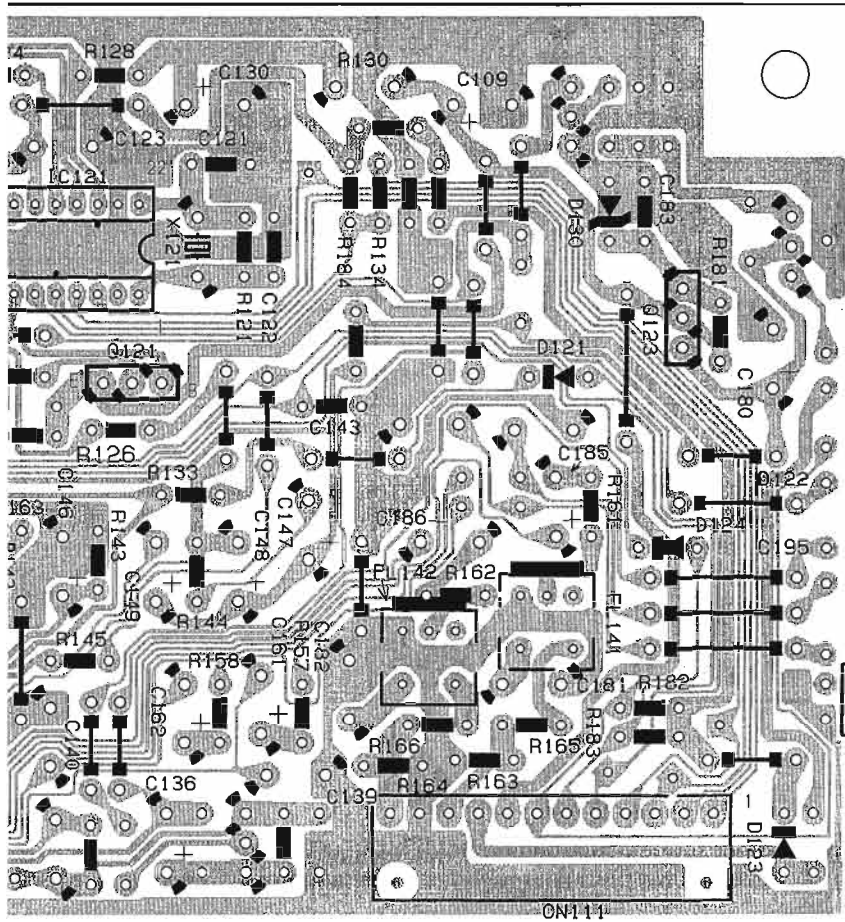

6

7

8

9

10

## Location List (ENA-178)

Symbol	X	Y	Symbol	X	Y	Symbol	X	Y
C101	3	E	C189	10	B	R132	4	D
C102	4	E	C190	9	B	R133	6	C
C103	3	E	C191	9	D	R134	6	E
C104	2	D	C192	10	D	R137	7	D
C105	4	D	C193	9	E	R138	5	B
C107	3	C	C194	9	E	R139	5	B
C109	6	E	C195	8	C	R140	4	A
C111	1	B	C196	9	D	R141	4	C
C112	1	B	C197	8	D	R142	5	C
C113	1	A	C199	10	E	R143	5	C
C117	3	B	CF101	3	D	R144	5	C
C118	3	A	CF102	3	C	R145	5	B
C121	5	E	CN111	6	B	R146	3	B
C122	6	D	CN112	9	E	R147	3	B
C123	5	E	D121	7	D	R148	3	B
C126	4	E	D122	8	C	R149	3	B
C128	5	E	D123	7	A	R150	4	C
C129	4	E	D124	7	C	R151	8	C
C130	5	E	D129	4	E	R152	8	B
C131	9	C	D130	7	E	R153	8	B
C132	9	B	D131	8	A	R155	8	C
C133	3	A	D132	9	D	R156	9	C
C135	4	A	D133	7	E	R157	6	B
C136	5	A	FL141	7	C	R158	6	B
C137	4	B	FL142	6	B	R159	7	C
C138	5	A	IC102	4	B	R160	7	C
C139	6	B	IC104	9	B	R161	7	C
C140	5	B	IC121	5	D	R162	6	C
C141	4	B	IC191	8	E	R163	6	B
C143	6	D	IC192	9	D	R164	6	B
C144	4	B	L111	2	A	R165	6	B
C146	5	C	Q101	3	D	R166	6	B
C147	6	C	Q102	3	D	R167	7	E
C148	6	C	Q103	4	D	R168	7	E
C149	5	C	Q111	2	B	R170	9	B
C150	4	B	Q112	2	C	R171	9	B
C153	6	B	Q113	1	C	R172	8	B
C154	8	C	Q114	1	A	R173	9	B
C155	5	A	Q121	5	D	R176	9	C
C156	4	E	Q123	7	D	R177	10	C
C157	3	B	Q131	8	C	R178	9	B
C158	3	C	Q132	6	B	R179	9	A
C159	7	C	Q133	7	D	R181	7	D
C160	6	C	Q134	7	E	R182	7	B
C161	6	B	R102	3	D	R183	7	B
C162	5	B	R103	3	D	R184	6	D
C163	5	C	R104	2	C	R191	10	D
C164	5	C	R105	3	D	RF101	2	E
C165	7	E	R106	4	D	T111	2	B
C166	8	B	R107	4	D	T141	4	C
C167	9	B	R108	4	D	T142	4	C
C168	2	A	R109	3	C	T151	8	A
C170	8	C	R110	1	A	TC101	8	B
C171	8	B	R111	3	B	X121	5	D
C172	9	B	R112	2	D	X191	10	D
C173	9	C	R113	2	D	X192	8	E
C174	9	C	R114	2	C			
C177	9	C	R115	1	C			
C178	10	C	R116	1	B			
C179	10	C	R119	2	D			
C180	7	D	R121	6	D			
C181	6	B	R122	5	E			
C182	6	B	R124	5	E			
C183	7	D	R126	5	C			
C184	4	C	R127	4	E			
C185	7	C	R128	5	E			
C186	6	C	R129	3	E			
C187	9	B	R130	6	E			
C188	10	C	R131	5	D			





■ CD Servo Board (ENN-488)

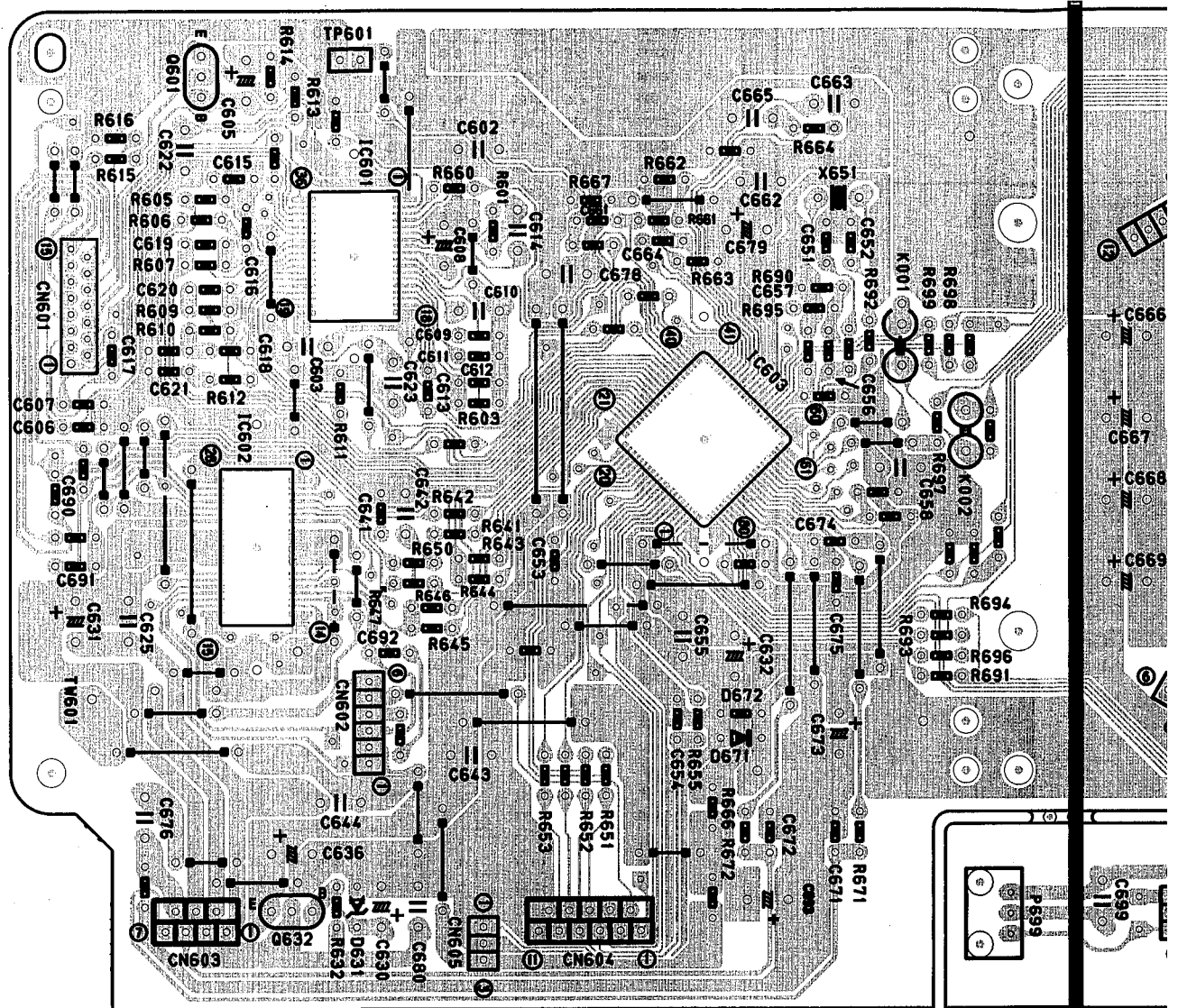

■ IC301  $\mu$ com Modify Board (END-107)

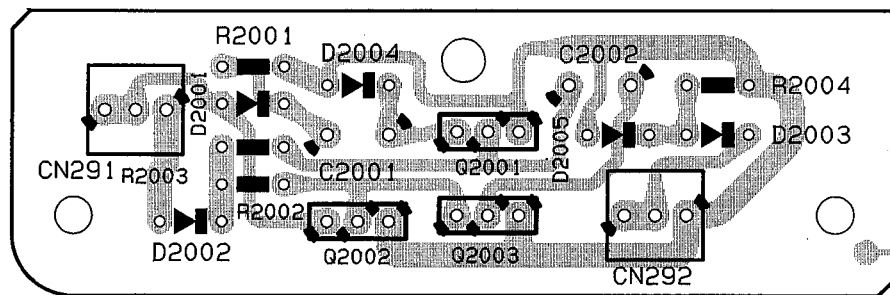

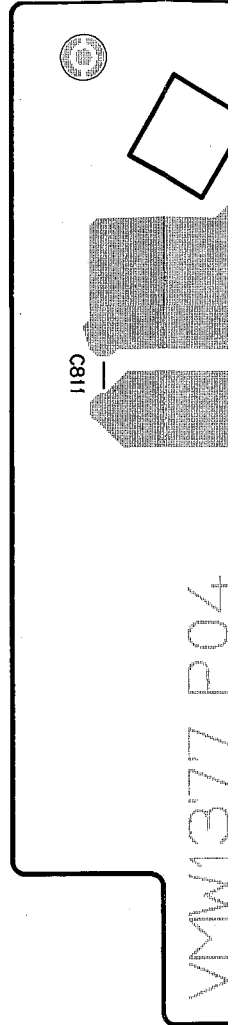
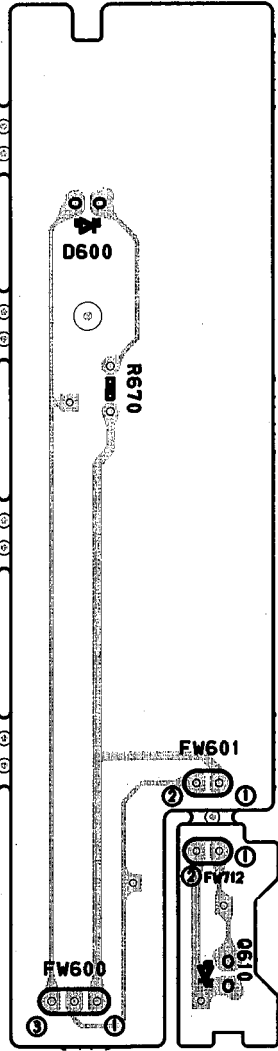
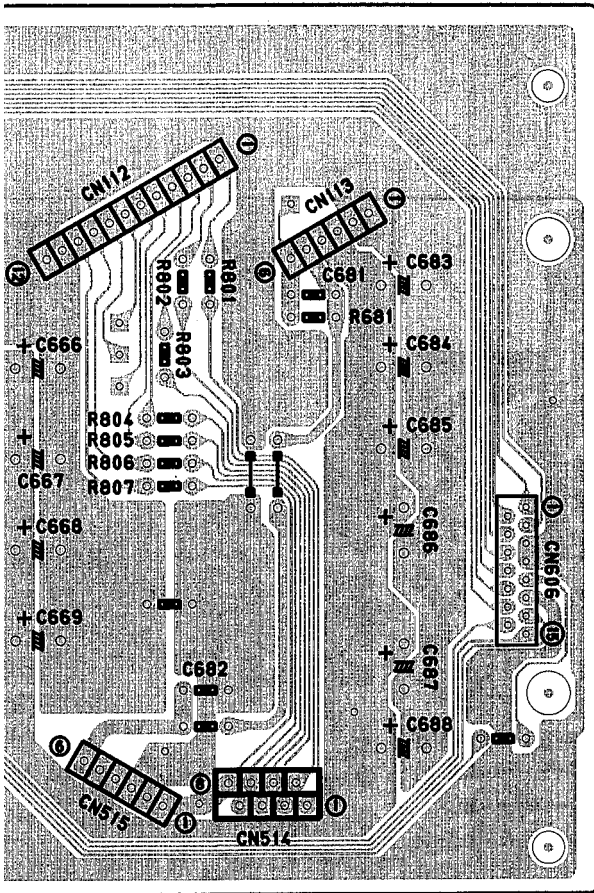

VMW1377 P04

r Mechanism Board (VMW1377)

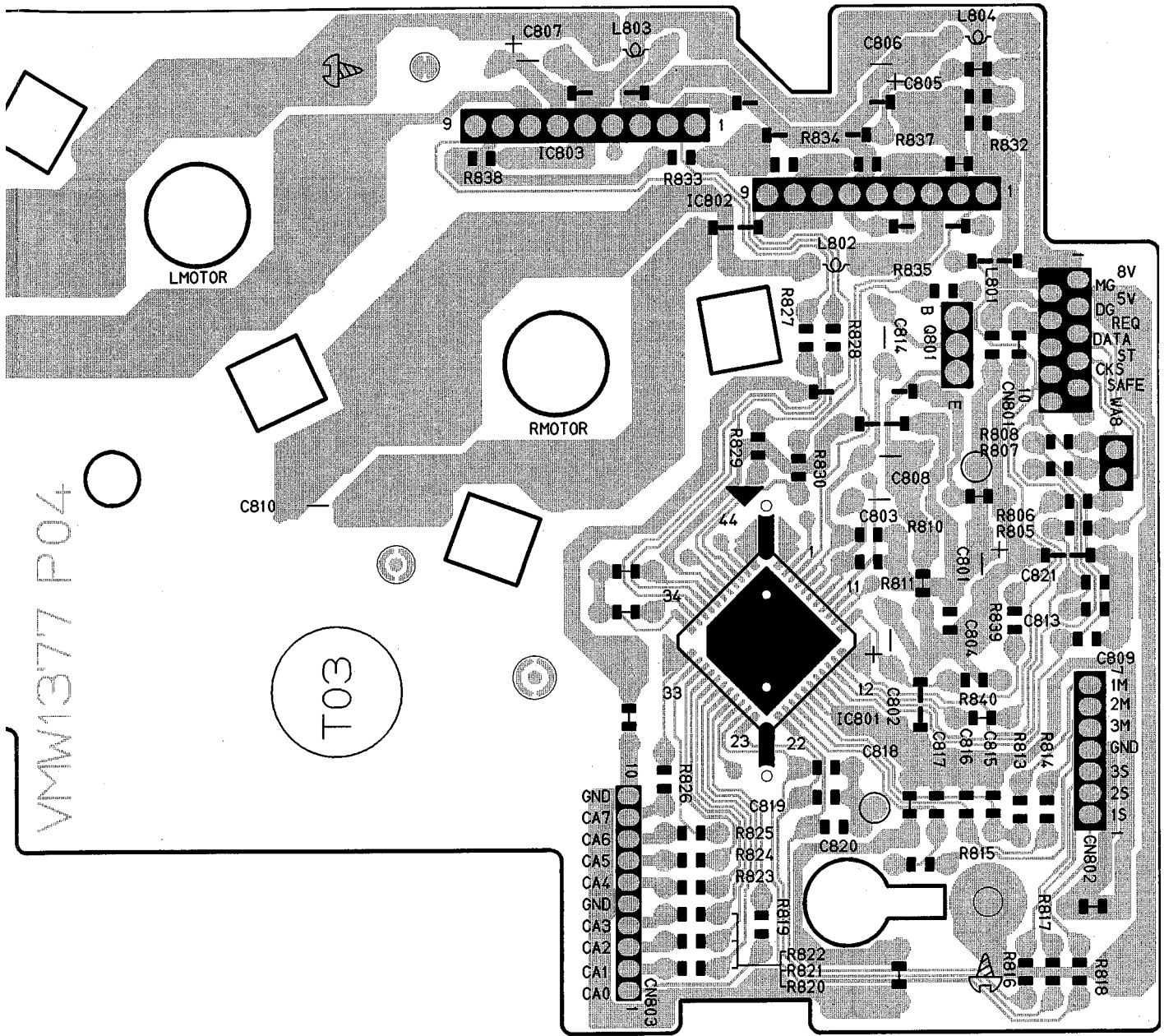

# PARTS LIST

\* All printed circuit boards and its assemblies are not available as service parts.

The Marks for Designated Areas  
 J . . . . the U. S. A.  
 C . . . . Canada  
 No marks indicates all areas.

- Contents -

General Exploded View and Parts List . . . . .	2-3
CD Changer Mechanism Ass'y and Parts List . . . . .	2-5
■ Grease Point . . . . .	2-5
CD Mechanism Ass'y and Parts List . . . . .	2-7
■ Grease Point . . . . .	2-7
Cassette Mechanism Ass'y and Parts List . . . . .	2-8
■ Grease Point . . . . .	2-8
Electrical Parts List . . . . .	2-10
(ENH-302) . . . . .	2-10
(ENB-248) . . . . .	2-12
(ENC-136) . . . . .	2-14
(ENN-488) . . . . .	2-17
(ENA-178) . . . . .	2-18
(END-107) . . . . .	2-19
(C3 Mecha.) . . . . .	2-19
Accessories List . . . . .	2-20
Packing Materials and Part Numbers . . . . .	2-21





# General Exploded View and Parts List

Block No. **M T M M**

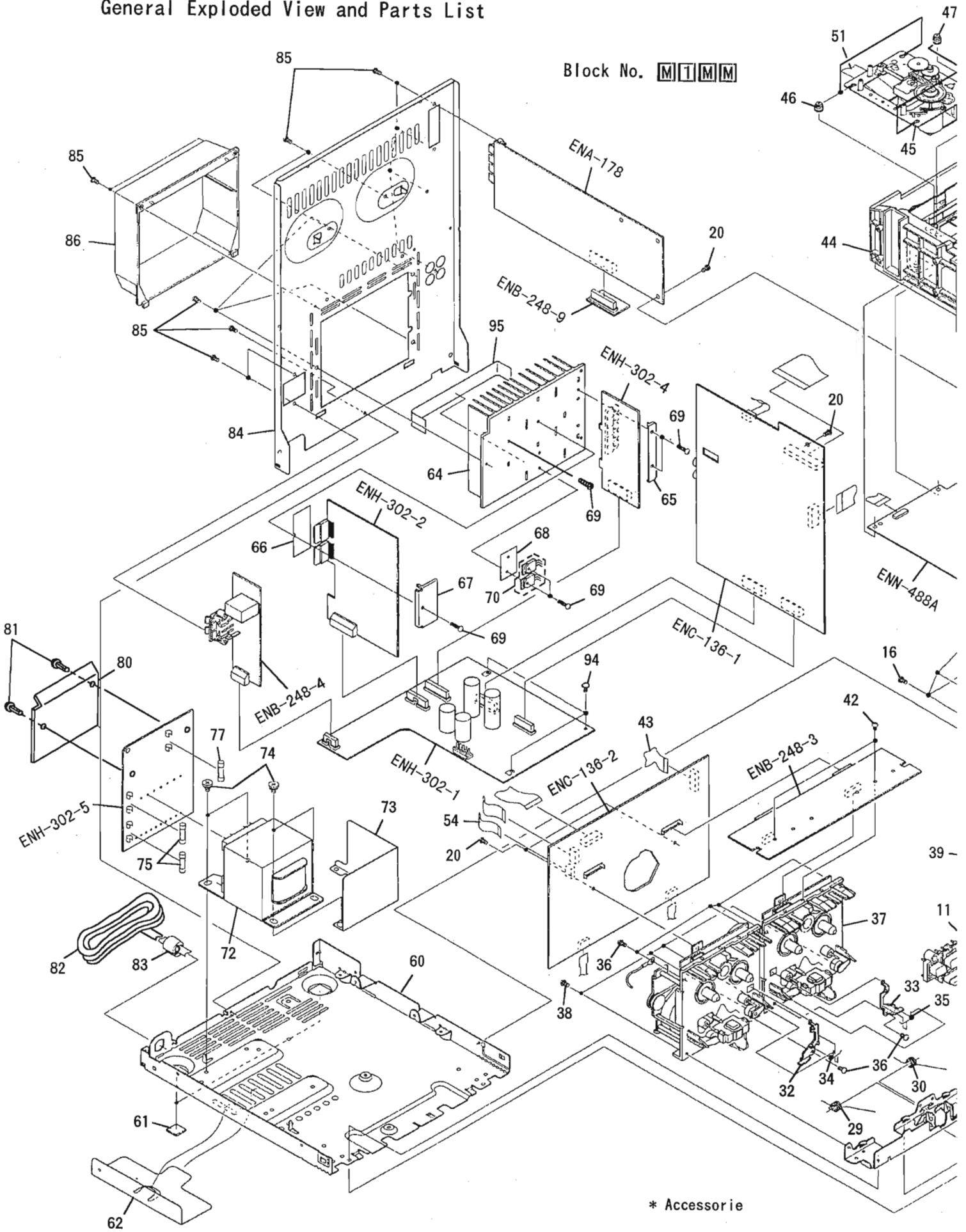

\* Accessorie



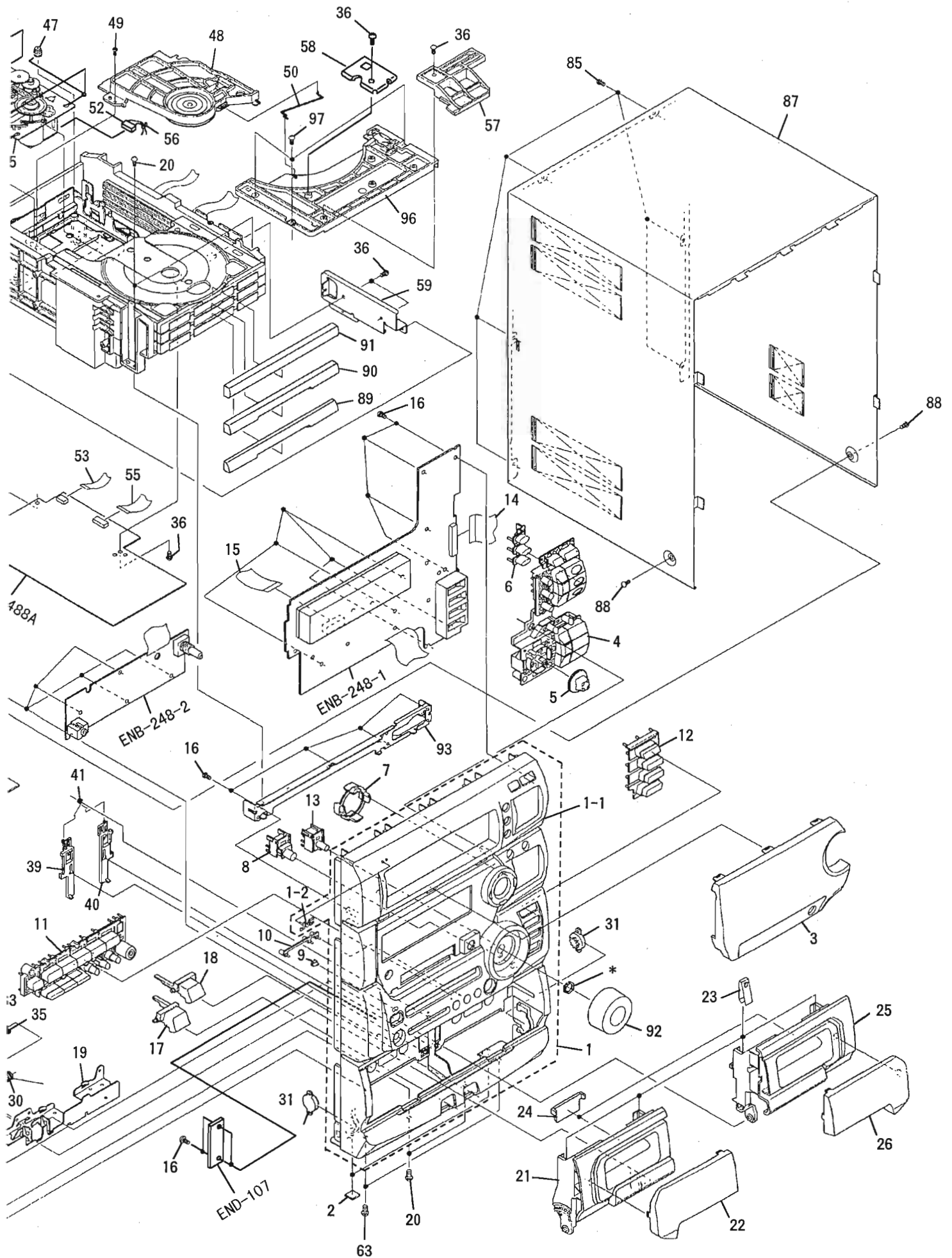

## ■ Parts List

Block No. **M1M1M1**

△	Item	Parts Number	Parts Name	Q'ty	Description	Area
	1	EFP-CAD661TJ(S)	FRONT PANEL ASSY	1		
	1-1	E103259-010SM	FRONT PANEL	1		
	1-2	E406971-221	JVC MARK	1		
	2	E75896-001	SPACER	2		
	3	E209142-016SM	WINDOW SCREEN	1		
	4	E209144-001SM	PUSH BUTTON	1	SOUND	
	5	E310199-001SM	SELECT KNOB	1		
	6	E310192-001SM	PUSH BUTTON	1	DISC	
	7	E310189-001SM	INDICATOR LENS	1	JOY	
	8	E310194-001SM	PUSH BUTTON	1	SURR. ON/OFF	
	9	E409555-001SM	INDICATOR LENS	1	STANDBY	
	10	E310191-001SM	INDICATOR LENS	1	REC. A/B	
	11	E209146-001SM	PUSH BUTTON ASSY	1		
	12	E209149-001SM	PUSH BUTTON	1	SOURCE	
	13	E310190-001SM	PUSH BUTTON	1	DEMO	
	14	VWF1225-20TTB	FLAT WIRE	1		
	15	VWF1216-13TTB	FLAT WIRE ASSY	1		
	16	SDSF2608Z	SCREW	20		
	17	E310196-001SM	EJECT BUTTON	1		
	18	E310197-001SM	EJECT BUTTON	1		
	19	E208588-002SM	HOLDER BRACKET	1		
	20	SBSG3008Z	TAPPING SCREW	11		
	21	E103261-003SM	CASSETTE HOLDER	1		
	22	E209151-001SM	CASSETTE LENS	1		
	23	E406713-001	CASS. SPRING	4		
	24	E310204-001SM	INDICATOR LENS	2		
	25	E103263-003SM	CASSETTE HOLDER	1		
	26	E209152-001SM	CASSETTE LENS	1		
	29	E408933-001	HOLDER SPRING	1		
	30	E408934-001	HOLDER SPRING	1		
	31	VYH7779-00D	DAMPER	2		
	32	E309477-222	EJECT SAFETY	1		
	33	E309478-222	EJECT SAFETY	1		
	34	E407801-002	SPRING	1		
	35	E407802-002	SPRING	1		
	36	SBSF3008Z	TAPPING SCREW	12		
		SBSF3008Z	TAPPING SCREW	13		J
	37	-----	CASSETTE MECHANISM ASSY	1		
	38	SBST3006Z	TAPPING SCREW	4		
	39	E309479-001SS	EJECT LEVER	1		
	40	E309480-001SS	EJECT LEVER	1		
	41	E408742-001SS	SPRING	1		
	42	SBST2604Z	SCREW	2		
	43	VWF1217-10TTB	FLAT WIRE	1		
	44	-----	CD CHANGER MECHANISM ASSY	1		
	45	-----	CD MECHANISM ASS'Y	1		
	46	FMYH4003-001	INSULATOR	2		
	47	FMYH4003-002	INSULATOR	2		
	48	VKS3703-00FMM	CLAMPER ASSY	1		
	49	SPST2606Z	TAPPING SCREW	1		
	50	VKW5187-001	ROD	1		
	51	QUQ110-1509AJ	FLAT WIRE	1		
	52	VDM1001-M001A	SOCKET WIRE ASSY	1		
	53	VWF1207-07TTB	FLAT WIRE	1		

■ Parts List

Block No. **M1M1M**

△	Item	Parts Number	Parts Name	Q'ty	Description	Area
	54	VWF1210-27TTB	FLAT WIRE ASSY	1	CN801-CN811	
	55	VWF1211-22TTB	FLAT WIRE ASSY	1		
	56	VYSA1R2-033	SPACER	1		
	57	E309662-001	DISK STOPPER	1		
	58	FMKL4008-001	LOD STOPPER	1		J
	59	E310198-001SM	P. W. BOARD BRACKET	1		
	60	E102616-230SM	CHASSIS BASE	1		
	61	E75896-006	FELT SPACER	2		
	62	E310075-001	COVER	1		
	63	SBST3008Z	TAPPING SCREW	2		
	64	E309789-001SM	HEAT SINK	1		
	65	E406969-002SM	SIDE BRACKET	1		
	66	FMPK4003-001	MICA SHEET	1		
	67	FMKL4007-001	HEAT SINK BRACKET	1		
	68	FMPK4004-001	MICA SHEET	1		
	69	SBSG3014CC	SCREW	6		
	70	JCE8005	TRANSISTOR KIT	1	Q757, Q758	
	72	QQT0156-001	POWER TRANSFORMER	1		
	73	E409015-001SM	SHIELD PLATE	1		
	74	E65389-002	SPECIAL SCREW	4		
△	75	QMF0007-4R0J1	FUSE	2	F101, 102 (T4. 0A/125V)	
△	77	QMF0007-3R15J1	FUSE	1	F001 (T3. 15A/125V)	
	80	LE40252-201A	PROTECT SHEET	1		
	81	E310243-002	PLASTIC RIVET	2		
△	82	QMP1D00-200H	POWER CORD	1		
△	83	QHS3876-162	CORD STOPPER	1		
	84	E103265-010SM	REAR PANEL	1		J
		E103265-011SM	REAR PANEL	1		C
	85	E73273-003	SPECIAL SCREW	19		
	86	E207356-002SM	REAR COVER	1		
	87	E103267-003SM	METAL COVER	1		
	88	SDSG3006M	TAPPING SCREW	2		
	89	E209153-001SM	CD FITTING	1	DISC 1	
	90	E209155-001SM	CD FITTING	1	DISC 2	
	91	E209157-001SM	CD FITTING	1	DISC 3	
	92	E310080-224SM	VOLUME KNOB	1		
	93	E310195-001SM	STAY BRACKET	1		
	94	GBSG3008CC	SCREW	3		
	95	EX0150010H09S11	FELT SPACER	1		
	96	VKS2250-003	TOP BRACKET	1		
	97	SBSF2608Z	SCREW	3		
	-	E307570-001	NUMBER LABEL	1		J
		E406709-001	CAUTION LABEL	1		C



# CD Changer Mechanism Ass'y and Parts List

■ Grease Point

Block No. M2MM

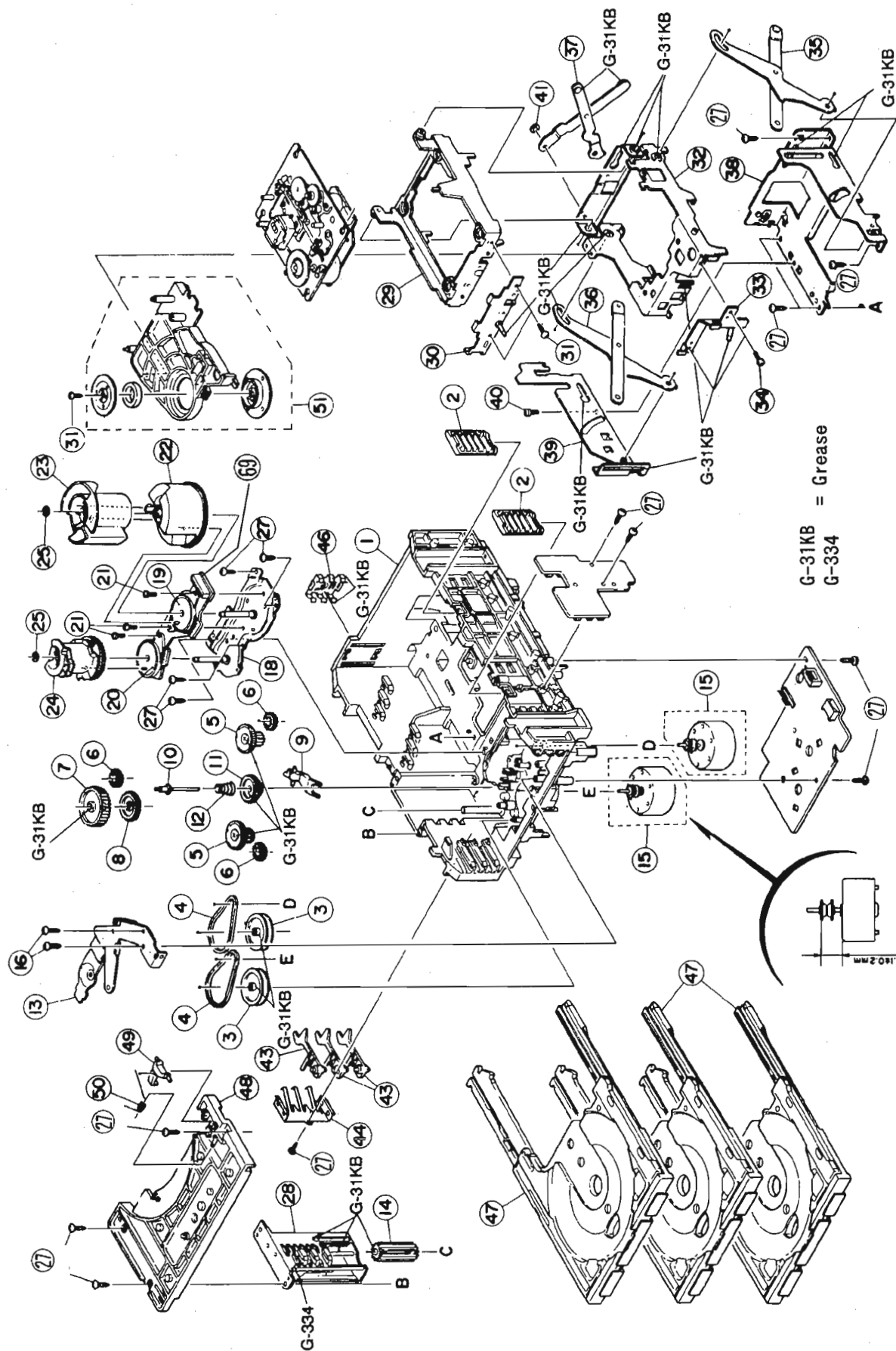

## ■ Parts List (Changer Mechanism Ass'y)

Block No. **M2MM**

△	Item	Parts Number	Parts Name	Q'ty	Description	Area
	1	VKS1144-003	CHASSIS BASE	1		
	2	VKS3698-003	TRAY GUIDE	2		
	3	VKS5532-003	PULLEY GEAR	2		
	4	VKB3000-164	DRIVE BELT	2		
	5	VKS5505-003	GEAR B	2		
	6	VKS5506-002	GEAR C	3		
	7	VKS5507-002	CROSS GEAR U	1		
	8	VKS5508-002	CROSS GEAR L	1		
	9	VKS5510-003	SELECT LEVER	1		
	10	VKH5769-001	GEAR STUD	1		
	11	VKS5511-002	SELECT GEAR	1		
	12	VKW5155-003	COMPRESS SPRING	1		
	13	VKM3846-002	GEAR BRACKET	1		
	14	VKS5509-002MM	CYLINDER GEAR	1		
	15	MSN5D257A-SA2	DC MOTOR ASSY	2		
	16	DPSP2616Z	SCREW	2		
	18	VKM3825-00A	CAM GEAR BASE ASSY	1		
	19	VKZ3172-00A	CAM SWITCH ASSY	1		
	20	VKZ3173-00A	CAM SWITCH ASSY	1		
	21	SPST2606Z	TAPPING SCREW	3		
	22	VKS2263-002MM	CAM R1	1		
	23	VKS2264-002MM	CAM R2	1		
	24	VKS2265-002MM	CAM GEAR L	1		
	25	WDL316050	SLIT WASHER	2		
	27	SBSF2608Z	TAPPING SCREW	15		
	28	VKS3702-00FMM	DRIVE UNIT	1		
	29	VKS2247-004	MECHA. HOLDER A	1		
	30	VKL7767-00B	MECHA. BRACKET ASSY	1		
	31	SBSF2606Z	TAPPING SCREW	3		
	32	VKM3860-00A	MECHA. HOLDER ASSY	1		
	33	VKL7802-00C	MECHA. HOLDER ASSY	1		
	34	SDST2604Z	SCREW	2		
	35	VKL7810-00A	LIFTER	1		
	36	VKL7811-00A	LIFTER	1		
	37	VKL7812-00A	LIFTER	1		
	38	VKL2732-002	LIFTER BASE	1		
	39	VKM3823-001	LIFTER BRACKET	1		
	40	SDST2604Z	SCREW	1		
	41	WDL266035-2	SLIT WASHER	1		
	43	VKS5514-002MM	LOCK LEVER	3		
	44	VKY3133-002MM	RETURN SPRING	1		
	46	VKY3134-003	SPRING	1		
	47	VKS2252-00D	TRAY ASSY	3		
	48	VKS2250-003	TOP BRACKET	1		
	49	VKS5515-002	S. TRAY STOPPER	1		
	50	VKW5156-004	TORSION SPRING	1		
	51	VKS3703-00FMM	CLAMPER ASSY	1		
	69	VMC0325-010	CONNECTOR	1		

# CD Mechanism Ass'y and Parts List

Block No. **M3MM**

■ Grease Point

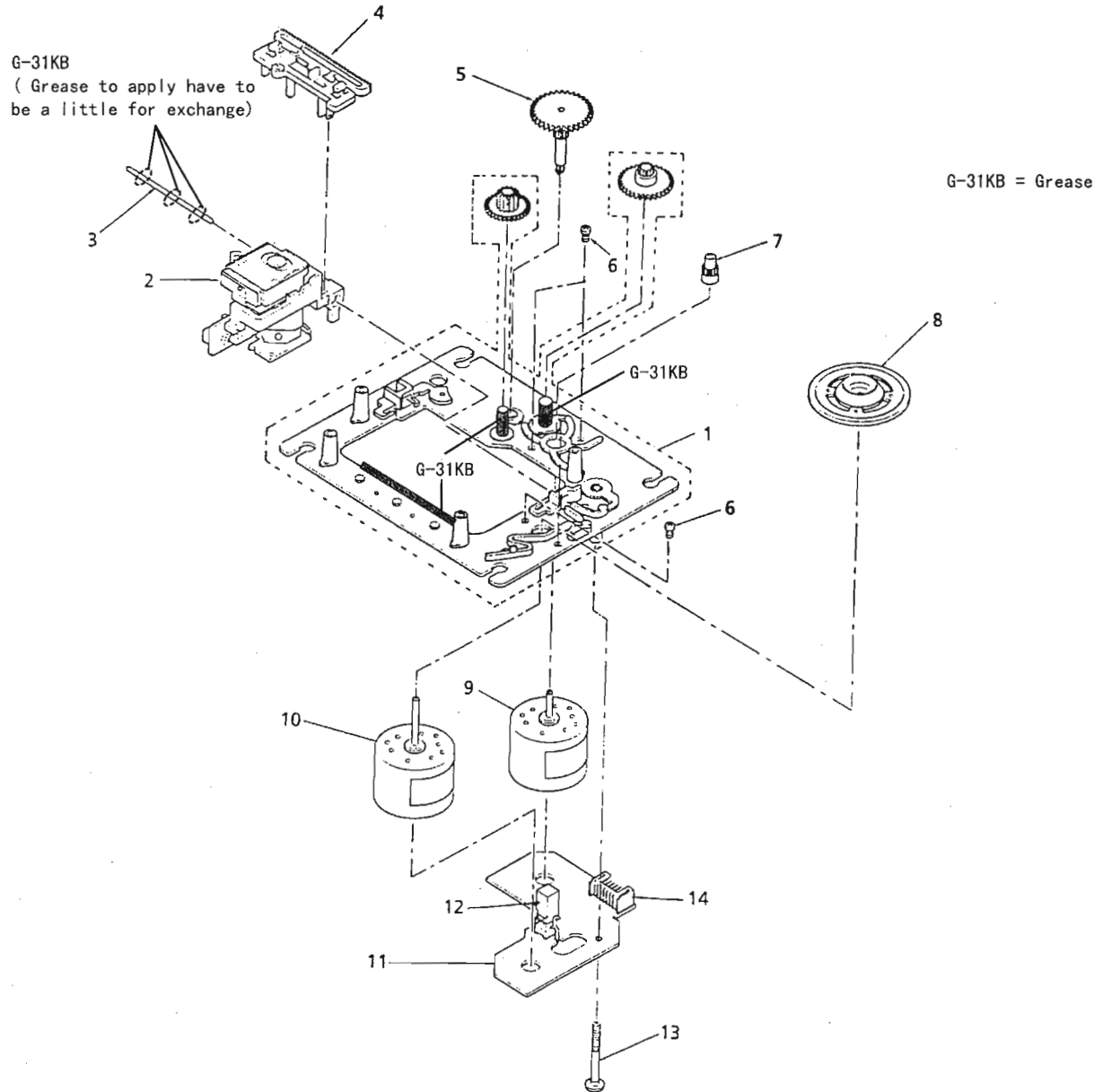

■ Parts List (CD Mechanism Ass'y)

△	Item	Parts Number	Parts Name	Q'ty	Description	Area
	1	EPB-002PK	MECHA. BASE ASSY	1		
	2	OPTIMA-150S	OPTICAL PICK UP	1		
	3	E406777-001	CD SHAFT	1		
	4	E307746-001	CD RACK	1		
	5	E307745-221SS	MECHA GEAR	1		
	6	SDSP2003N	SCREW	3		
	7	E406750-001	PINION GEAR	1		
	8	EPB309173A	TURN TABLE	1		
	9	E406784-001	FEED MOTOR	1		
	10	E406783-001	SPINDLE MOTOR	1		
	11	EMW10190-001(S)	P. C. BOARD	1		
	12	ESB1100-005	LEAF SWITCH	1		
	13	E75832-001	SCREW	1		
	14	EMV5109-006B	CONN. TERMINAL	1	6PIN	

Cassette Mechanism Ass'y and Parts List

■ Grease Point

Block No. **M4MM**

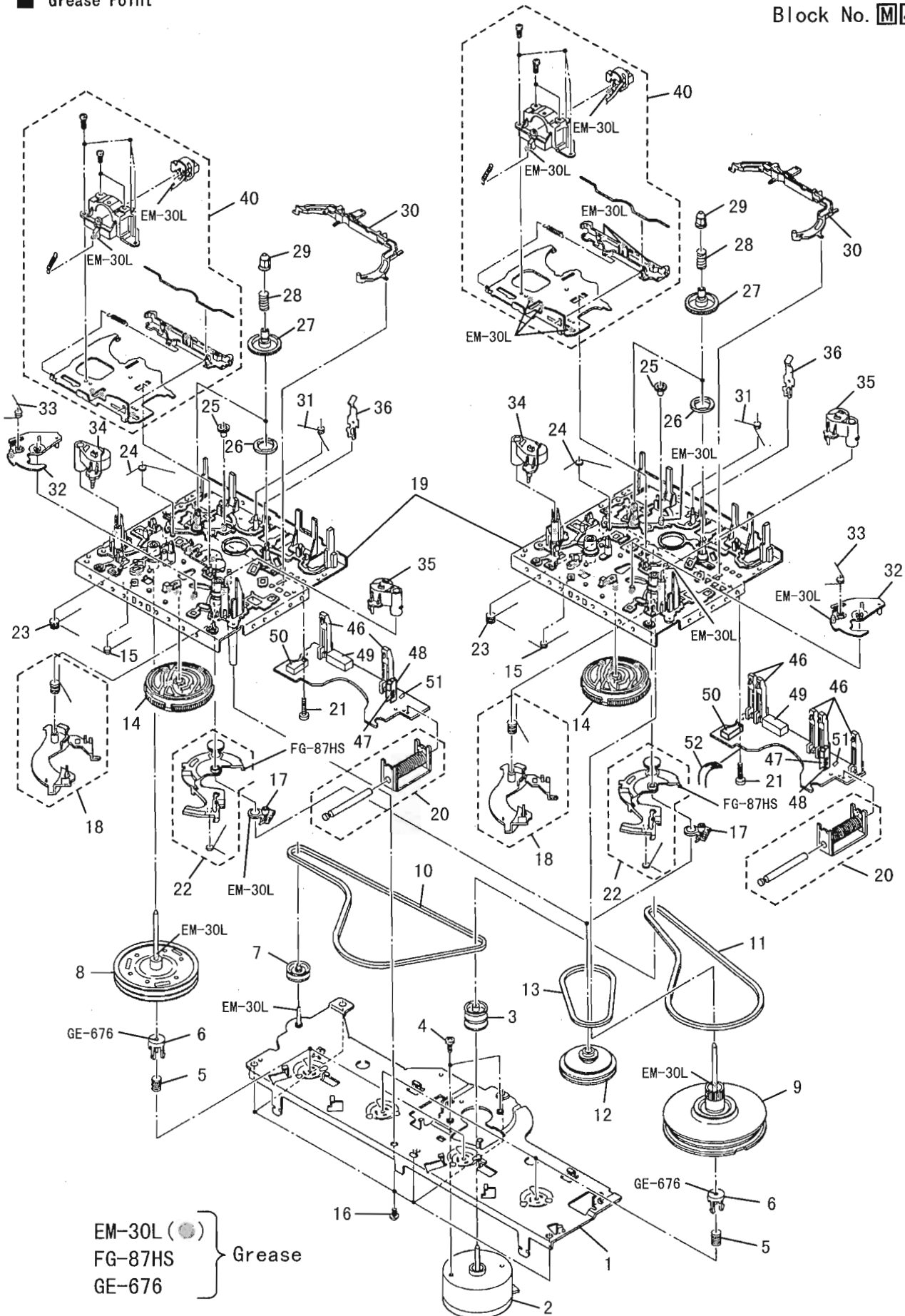

EM-30L (●)  
 FG-87HS  
 GE-676 } Grease



## ■ Parts List (Cassette Mechanism Ass'y)

Block No. **M4MM**

△	Item	Parts Number	Parts Name	Q'ty	Description	Area
	1	VKM3835-00A	FLYWHEEL BRACKET	1		
	2	MMI-6H2LWK	DC MOTOR	1		
	3	VKR4740-003	MOTOR PULLEY	1		
	4	SPSP2603Z	WOOD SCREW	2		
	5	VKW5177-002	SPRING	1		
	6	VKS5524-001	THRUST GUIDE	1		
	7	VKR4741-002	IDLER PULLEY	1		
	8	VKF3202-00A	F. WHEEL (L) ASSY	2		
	9	VKF3200-00A	F. WHEEL (R) ASSY	2		
	10	VKB3000-161	CAPSTAN BELT	1		
	11	VKB3000-162	CAPSTAN BELT	1		
	12	VKS5523-00G	MAIN PULLY ASSY	2		
	13	VKB3000-167	REEL BELT	2		
	14	VKS1150-001	CONTROL CAM	2		
	15	VKW5170-002	SPRING	2		
	16	SBSF2608Z	TAPPING SCREW	6		
	17	VKS3719-001	RING	2		
	18	VKS5525-00B	TRIGGER ARM ASSY	2		
	19	VKS1151-00A	CHASSIS BASE ASSY	2		
	20	VGP2401-00A	SOLENOID ASSY	2		
	21	SDST2612Z	SCREW	2		
	22	VKS3714-00B	F. F/REW. ARM	2		
	23	VKW5173-001	SPRING	2		
	24	VKW5202-002	SPRING	2		
	25	VKS5519-002	IDLER GEAR	2		
	26	VKZ4690-002	MAGNET	2		
	27	VKS3707-002	REEL GEAR	2		
	28	VKW5162-002	SPRING	4		
	29	VKS3708-002	REEL CAP	4		
	30	VKS2261-002	REEL STOPPER	2		
	31	VKW5178-001	BRAKE SPRING	2		
	32	VKS2255-001	DIRECTION LEVER	2		
	33	VKW5163-001	SPRING	2		
	34	VKP4232-00B	PINCH ROLLER	2		
	35	VKP4231-00B	PINCH ROLLER	4		
	36	VKY4670-001	CASSETTE SPRING	2		
	40	VKM3834-00F	HEAD MOUNT ASSY	1	A Mecha.	
		VKM3832-00F	HEAD MOUNT ASSY	1	B Mecha.	
	46	MXS00220MVL0	CASSETTE SWITCH	7		
	47	DN6851-HI	I. C (M)	2		
	48	VKS3630-001MM	I. C. PROTECTOR	2		
	49	VMC0314-P08	CONNECT TERMINAL	1	A Mecha.	
		VMC0314-P14	CONNECT TERMINAL	1	B Mecha.	
	50	QSEC001-E03	LEVER SWITCH	2		
	51	1SR139-400	SI DIODE	2		
	52	VWSC04-11A13K	FLAT WIRE ASSY	1		

## ■ Electrical Parts List (ENH-302)

△	Item	Parts Number	Description	Area
		I. C. S		
	IC701	TDA7294	I. C (M)	
	IC702	TDA7294	I. C (M)	
		DIODES		
	D001	1N5402M-20	DIODE	
	D002	1N5402M-20	DIODE	
	D003	1N5402M-20	DIODE	
	D004	1N5402M-20	DIODE	
	D011	30D2FC	GE. DIODE	
	D012	30D2FC	GE. DIODE	
	D013	30D2FC	GE. DIODE	
	D014	30D2FC	GE. DIODE	
	D015	30D2FC	GE. DIODE	
	D016	30D2FC	GE. DIODE	
	D017	1SR35-100	SI. DIODE	
	D018	1SR35-100	SI. DIODE	
	D019	MTZ30JC	ZENER DIODE	
	D020	MTZ5. 6JC	ZENER DIODE	
	D021	MTZ5. 1JB	ZENER DIODE	
	D022	1SS133	SI. DIODE	
	D023	1SS133	SI. DIODE	
	D024	1SS133	SI. DIODE	
	D025	1SS133	SI. DIODE	
	D027	1SR35-100	SI. DIODE	
	D030	MTZ9. 1JC	ZENER DIODE	
	D060	MTZ5. 1JB	ZENER DIODE	
	D061	MTZ11JC	ZENER DIODE	
	D062	MTZ13JC	ZENER DIODE	
	D063	MTZ11JC	ZENER DIODE	
	D064	MTZ13JC	ZENER DIODE	
	D065	MTZ8. 2JC	ZENER DIODE	
	D066	MTZ13JC	ZENER DIODE	
	D067	MTZ13JC	ZENER DIODE	
	D068	MTZ13JC	ZENER DIODE	
	D069	MTZ13JC	ZENER DIODE	
	D070	MTZ13JC	ZENER DIODE	
	D703	1SS133	SI. DIODE	
	D704	1SS133	SI. DIODE	
	D719	1SS133	SI. DIODE	
	D720	1SS133	SI. DIODE	
	D728	1SS133	SI. DIODE	
	D751	1SS133	SI. DIODE	
	D752	1SS133	SI. DIODE	
	D753	1SS133	SI. DIODE	
	D754	1SS133	SI. DIODE	
	D755	1SS133	SI. DIODE	
	D756	1SS133	SI. DIODE	
	D757	MTZ3. 9JB	ZENER DIODE	
	D758	MTZ3. 9JB	ZENER DIODE	
	D759	1SS133	SI. DIODE	
	D760	1SS133	SI. DIODE	
	D1060	MTZ2. 4JB	ZENER DIODE	
		TRANSISTORS		
	Q001	2SB1187 (F. G)	SI. TRANSISTOR	
	Q003	KRC107M-T	DIGITAL TRANSISTOR	
	Q004	KRC107M-T	DIGITAL TRANSISTOR	
	Q005	KRC102M-T	DIGITAL TRANSISTOR	
	Q040	2SC945A	SI. TRANSISTOR	
	Q060	2SD2061 (F. G)	SI. TRANSISTOR	
	Q061	2SC945A	SI. TRANSISTOR	
	Q062	2SC945A	SI. TRANSISTOR	
	Q063	2SD2061 (F. G)	SI. TRANSISTOR	
	Q064	2SA933S (RS)	SI. TRANSISTOR	
	Q065	2SC945A	SI. TRANSISTOR	
	Q066	2SD2061 (F. G)	SI. TRANSISTOR	
	Q067	2SA933S (RS)	SI. TRANSISTOR	
	Q068	2SC945A	SI. TRANSISTOR	
	Q069	2SD2061 (F. G)	SI. TRANSISTOR	
	Q070	2SC945A	SI. TRANSISTOR	
	Q071	2SB1187 (F. G)	SI. TRANSISTOR	
	Q072	2SA933S (RS)	SI. TRANSISTOR	
	Q073	KRA104M-T	DIGITAL TRANSISTOR	
	Q074	DTC144ES	DIGITAL TRANSISTOR	
	Q075	KRC104M-T	DIGITAL TRANSISTOR	
	Q076	DTA144ES	DIGITAL TRANSISTOR	
	Q701	2SA1038 (R. S)	SI. TRANSISTOR	

△	Item	Parts Number	Description	Area
	Q702	2SA1038 (R. S)	SI. TRANSISTOR	
	Q726	2SC2389 (S. E)	SI. TRANSISTOR	
	Q727	2SA1038 (R. S)	SI. TRANSISTOR	
	Q728	2SC1740S (R. S)	SI. TRANSISTOR	
	Q733	2SD2144S (VW)	SI. TRANSISTOR	
	Q734	2SD2144S (VW)	SI. TRANSISTOR	
	Q735	2SD2144S (VW)	SI. TRANSISTOR	
	Q736	2SD2144S (VW)	SI. TRANSISTOR	
	Q737	KRA111M-T	DIGITAL TRANSISTOR	
	Q751	2SC1685	SI. TRANSISTOR	
	Q752	2SA933S (RS)	SI. TRANSISTOR	
	Q753	2SC1685	SI. TRANSISTOR	
	Q754	2SA933S (RS)	SI. TRANSISTOR	
	Q755	2SA965 (Y)	SI. TRANSISTOR	
	Q756	2SC2235 (O. Y)	SI. TRANSISTOR	
	Q1057	2SK301 (P. Q)	F. E. T.	
		CAPACITORS		
	C001	QFV82AJ-104	0. 1MF 100V THIN FILM CAP.	
	C002	QFV82AJ-104	0. 1MF 100V THIN FILM CAP.	
	C003	QFV82AJ-104	0. 1MF 100V THIN FILM CAP.	
	C004	QETM1HM-228	2200MF 50V E. CAP.	
	C005	QETM1HM-228	2200MF 50V E. CAP.	
	C011	QFV81HJ-104	0. 1MF 50V THIN FILM CAP.	
	C012	QFV81HJ-104	0. 1MF 50V THIN FILM CAP.	
	C013	QFV81HJ-104	0. 1MF 50V THIN FILM CAP.	
	C014	QETM1VM-228J7	2200MF 35V E. CAP.	
	C015	QETM1VM-228J7	2200MF 35V E. CAP.	
	C016	QETN1VM-107Z	100MF 35V E. CAP.	
	C017	QETN1JM-476Z	47MF 63V E. CAP.	
	C018	QETN1HM-226Z	22MF 50V AL E. CAP.	
	C019	QCVB1CM-103Y	0. 01MF 16V CER. CAP.	
	C020	QETN1HM-226Z	22MF 50V AL E. CAP.	
	C021	QETN1HM-475Z	4. 7MF 50V AL E. CAP.	
	C022	QETN1HM-475Z	4. 7MF 50V AL E. CAP.	
	C023	QETN1HM-225Z	2. 2MF 50V AL E. CAP.	
	C024	QETN1EM-106Z	10MF 25V E. CAP.	
	C032	QETN1AM-477Z	470MF 10V E. CAP.	
	C033	QFLB1HJ-103	0. 01MF 50V MYLAR CAP.	
	C060	QETN1EM-226Z	22MF 25V E. CAP.	
	C061	QCF21HP-103A	0. 01MF 50V CER. CAP.	
	C062	QETN1EM-226Z	22MF 25V E. CAP.	
	C063	QETN1EM-226Z	22MF 25V E. CAP.	
	C064	QCF21HP-103A	0. 01MF 50V CER. CAP.	
	C065	QETN1EM-226Z	22MF 25V E. CAP.	
	C066	QETN1EM-226Z	22MF 25V E. CAP.	
	C067	QCF21HP-103A	0. 01MF 50V CER. CAP.	
	C068	QETN1EM-226Z	22MF 25V E. CAP.	
	C069	QETN1EM-226Z	22MF 25V E. CAP.	
	C070	QCF21HP-103A	0. 01MF 50V CER. CAP.	
	C071	QETN1EM-226Z	22MF 25V E. CAP.	
	C072	QETN1EM-226Z	22MF 25V E. CAP.	
	C073	QCF21HP-103A	0. 01MF 50V CER. CAP.	
	C074	QETN1EM-226Z	22MF 25V E. CAP.	
	C103	QFLB1HJ-103	0. 01MF 50V MYLAR CAP.	
	C703	QCBB1HK-101Y	100PF 50V CER. CAP.	
	C704	QCBB1HK-101Y	100PF 50V CER. CAP.	
	C705	QCBB1HK-181Y	180PF 50V CER. CAP.	
	C706	QCBB1HK-181Y	180PF 50V CER. CAP.	
	C707	QETN1EM-476Z	47MF 25V E. CAP.	
	C708	QETN1EM-476Z	47MF 25V E. CAP.	
	C709	QCSB1HJ-100Y	10PF 50V CER. CAP.	
	C710	QCSB1HJ-100Y	10PF 50V CER. CAP.	
	C711	QETN1HM-226Z	22MF 50V AL E. CAP.	
	C712	QETN1HM-226Z	22MF 50V AL E. CAP.	
	C713	QFV81HJ-104	0. 1MF 50V THIN FILM CAP.	C
	C714	QFV81HJ-104	0. 1MF 50V THIN FILM CAP.	C
	C715	QFV81HJ-104	0. 1MF 50V THIN FILM CAP.	C
	C716	QFV81HJ-104	0. 1MF 50V THIN FILM CAP.	C
	C717	QFLB1HJ-473	0. 047MF 50V MYLAR CAP.	J
	C718	QFLB1HJ-473	0. 047MF 50V MYLAR CAP.	J
	C721	QETN1HM-225Z	2. 2MF 50V AL E. CAP.	
	C722	QETN1HM-225Z	2. 2MF 50V AL E. CAP.	
	C726	QETN1EM-106Z	10MF 25V E. CAP.	
	C729	QETN1CM-476Z	47MF 16V AL E. CAP.	
	C751	QCY31HK-272Z	2700PF 50V CER. CAP.	
	C752	QCY31HK-272Z	2700PF 50V CER. CAP.	

## ■ Electrical Parts List (ENH-302)

△	Item	Parts Number	Description	Area
	C753	QCY31HK-472Z	4700PF 50V CER. CAP.	
	C754	QCY31HK-472Z	4700PF 50V CER. CAP.	
	C755	QFV81HJ-105	1MF 50V THIN FILM CAP.	
	C756	QFV81HJ-105	1MF 50V THIN FILM CAP.	
	C757	QCB1CM-152Y	1500PF 16V CER. CAP.	
	C758	QCB1CM-152Y	1500PF 16V CER. CAP.	
	C799	QCVB1CM-103Y	0.01MF 16V CER. CAP.	
	C1017	QFLB1HJ-823	0.082MF 50V MYLAR CAP.	
	C1018	QETN1HM-224Z	0.22MF 50V AL. E. CAP.	
		RESISTORS		
△	R001	QR0128K-275EM	2.7M 1/2W COMPOSITION	
	R002	QRD14CJ-4R7SX	4.7 1/4W UNF. CARBON R	J
	R003	QRD167J-332	3.3K 1/6W CARBON RES.	
	R004	QRD167J-223	22K 1/6W CARBON RES.	
	R005	QRD161J-104	100K 1/6W CARBON RES.	
△	R006	QRD14CJ-2R2SX	2.2 1/4W UNF. CARBON R	
	R008	QRD161J-103	10K 1/6W CARBON RES.	
	R009	QRD161J-103	10K 1/6W CARBON RES.	
	R010	QRD161J-472	4.7K 1/6W CARBON RES.	
	R011	QRD161J-102	1K 1/6W CARBON RES.	
	R012	QRD167J-223	22K 1/6W CARBON RES.	
	R013	QRD161J-103	10K 1/6W CARBON RES.	
	R014	QRD161J-104	100K 1/6W CARBON RES.	
△	R030	QRD14CJ-221S	220 1/4W UNF. CARBON R	
	R040	QRD12CJ-471SX	470 1/2W UNF. CARBON R	
	R041	QRD12CJ-471SX	470 1/2W UNF. CARBON R	
	R042	QRD161J-222	2.2K 1/6W CARBON RES.	
	R045	QRD161J-222	2.2K 1/6W CARBON RES.	
	R060	QRG01DJ-180X	18 1W OXIDE METAL	
	R061	QRG01DJ-180X	18 1W OXIDE METAL	
	R062	QRD161J-331	330 1/6W CARBON RES.	
	R063	QRD161J-331	330 1/6W CARBON RES.	
	R064	QRD161J-122	1.2K 1/6W CARBON RES.	
	R065	QRD161J-561	560 1/6W CARBON RES.	
	R066	QRD161J-561	560 1/6W CARBON RES.	
	R067	QRD161J-122	1.2K 1/6W CARBON RES.	
	R068	QRD161J-331	330 1/6W CARBON RES.	
△	R069	QRD125J-220	22 1/2W UNF. CARBON R	
△	R070	QRD12CJ-330S	33 1/2W UNF. CARBON R	
	R071	QRD161J-221	220 1/6W CARBON RES.	
	R072	QRD161J-681	680 1/6W CARBON RES.	
	R073	QRD161J-182	1.8K 1/6W CARBON RES.	
△	R074	QRD125J-180	18 1/2W UNF. CARBON R	
△	R075	QRD125J-220	22 1/2W UNF. CARBON R	
	R076	QRD161J-221	220 1/6W CARBON RES.	
	R077	QRD161J-681	680 1/6W CARBON RES.	
	R078	QRD161J-182	1.8K 1/6W CARBON RES.	
	R079	QRG022J-120A	12 2W OXIDE METAL	
	R081	QRD167J-272	2.7K 1/6W CARBON RES.	
	R082	QRD167J-562	5.6K 1/6W CARBON RES.	
	R083	QRG01DJ-150X	15 1W O.M. FILM	
	R084	QRD167J-272	2.7K 1/6W CARBON RES.	
	R085	QRD167J-562	5.6K 1/6W CARBON RES.	
△	R701	QRD14CJ-100SX	10 1/4W UNF. CARBON R	
△	R702	QRD14CJ-100SX	10 1/4W UNF. CARBON R	
	R703	QRD161J-563	56K 1/6W CARBON RES.	
	R704	QRD161J-563	56K 1/6W CARBON RES.	
△	R705	QRD14CJ-182SX	1.8K 1/4W UNF. CARBON R	
△	R706	QRD14CJ-182SX	1.8K 1/4W UNF. CARBON R	
	R707	QRD161J-563	56K 1/6W CARBON RES.	
	R708	QRD161J-563	56K 1/6W CARBON RES.	
△	R709	QRX014J-R22	0.22 1W METAL FILM R	
△	R710	QRX014J-R22	0.22 1W METAL FILM R	
△	R711	QRX014J-R22	0.22 1W METAL FILM R	
△	R712	QRX014J-R22	0.22 1W METAL FILM R	
△	R713	QRD14CJ-100SX	10 1/4W UNF. CARBON R	
△	R714	QRD14CJ-100SX	10 1/4W UNF. CARBON R	
△	R715	QRD14CJ-100SX	10 1/4W UNF. CARBON R	
△	R716	QRD14CJ-100SX	10 1/4W UNF. CARBON R	
	R717	QRD161J-122	1.2K 1/6W CARBON RES.	
	R718	QRD161J-122	1.2K 1/6W CARBON RES.	
	R719	QRD167J-223	22K 1/6W CARBON RES.	
	R720	QRD167J-223	22K 1/6W CARBON RES.	
	R721	QRD161J-103	10K 1/6W CARBON RES.	
	R722	QRD161J-103	10K 1/6W CARBON RES.	
	R723	QRD161J-473	47K 1/6W CARBON RES.	

△	Item	Parts Number	Description	Area
	R724	QRD161J-473	47K 1/6W CARBON RES.	
	R725	QRD161J-104	100K 1/6W CARBON RES.	
	R726	QRD161J-823	82K 1/6W CARBON RES.	
	R727	QRD161J-104	100K 1/6W CARBON RES.	
	R728	QRD161J-103	10K 1/6W CARBON RES.	
	R729	QRD161J-104	100K 1/6W CARBON RES.	
	R730	QRD161J-103	10K 1/6W CARBON RES.	
	R733	QRD161J-473	47K 1/6W CARBON RES.	
	R734	QRD161J-473	47K 1/6W CARBON RES.	
	R735	QRD161J-473	47K 1/6W CARBON RES.	
	R736	QRD161J-473	47K 1/6W CARBON RES.	
	R739	QRG01DJ-821X	820 1W OXIDE METAL	
	R740	QRG01DJ-821X	820 1W OXIDE METAL	
	R751	QRD167J-223	22K 1/6W CARBON RES.	
	R752	QRD167J-223	22K 1/6W CARBON RES.	
	R753	QRD161J-222	2.2K 1/6W CARBON RES.	
	R754	QRD161J-222	2.2K 1/6W CARBON RES.	
	R755	QRD161J-221	220 1/6W CARBON RES.	
	R756	QRD161J-221	220 1/6W CARBON RES.	
	R757	QRD167J-223	22K 1/6W CARBON RES.	
	R758	QRD167J-223	22K 1/6W CARBON RES.	
	R759	QRD167J-682	6.8K 1/6W CARBON RES.	
	R760	QRD167J-682	6.8K 1/6W CARBON RES.	
	R761	QRD161J-222	2.2K 1/6W CARBON RES.	
	R762	QRD161J-222	2.2K 1/6W CARBON RES.	
	R763	QRD167J-223	22K 1/6W CARBON RES.	
	R764	QRD167J-223	22K 1/6W CARBON RES.	
	R765	QRG01DJ-182X	1.8K 1W OXIDE METAL	
	R766	QRG01DJ-182X	1.8K 1W OXIDE METAL	
△	R767	QRD14CJ-681SX	680 1/4W UNF. CARBON R	
△	R768	QRD14CJ-681SX	680 1/4W UNF. CARBON R	
	R769	QRD14CJ-821SX	820 1/4W CARBON RES.	
	R770	QRD14CJ-821SX	820 1/4W CARBON RES.	
	R771	QRD161J-821	820 1/6W CARBON RES.	
	R772	QRD161J-821	820 1/6W CARBON RES.	
△	R773	QRD14CJ-101S	100 1/4W UNF. CARBON R	
△	R774	QRD14CJ-101S	100 1/4W UNF. CARBON R	
	R775	QRD161J-471	470 1/6W CARBON RES.	
	R776	QRD161J-471	470 1/6W CARBON RES.	
	R777	QRD14CJ-4R7SX	4.7 1/4W UNF. CARBON R	
	R778	QRD14CJ-4R7SX	4.7 1/4W UNF. CARBON R	
	R1056	QRD161J-392	3.9K 1/6W CARBON RES.	
	R1057	QRD161J-105	1M 1/6W CARBON RES.	
	R1058	QRD161J-475	4.7M 1/6W CARBON RES.	
	R1059	QRD161J-473	47K 1/6W CARBON RES.	
	R1060	QRD167J-153	15K 1/6W CARBON RES.	
		OTHERS		
		EMW10687-102	PRINTED BOARD	
		QWE880-12RR	VINYL WIRE	
	L701	EQL0011-R45J1	INDUCTOR	
	L702	EQL0011-R45J1	INDUCTOR	
	CN002	EMV7163-011	CONNECT TERMINAL	
	CN003	EMV7163-010	CONNECT TERMINAL	
	CN005	EMV7163-006	CONNECT TERMINAL	
	CN006	EMV7163-010	CONNECT TERMINAL	
	CN007	EMV7163-009	CONNECT TERMINAL	
	CN009	EMV5138-005	CONNECT TERMINAL	
	CN012	EMV5163-011R	CONNECT TERMINAL	
	CN013	EMV5163-010R	CONNECT TERMINAL	
	CN019	EWS285-002J	SOCKET WIRE ASSY	
	CN111	EMV7145-004Z	SOCKET ASSY	
	CN915	EMV7145-003Z	SOCKET ASSY	
	EP001	EMZ4002-002Z	EARTH PLATE	
	EP002	EMZ4002-002Z	EARTH PLATE	
	FT011	EMG7331-003Z	FUSE CLIP	
	FT012	EMG7331-003Z	FUSE CLIP	
	FT511	EMG7331-003Z	FUSE CLIP	
	FT512	EMG7331-003Z	FUSE CLIP	
	FT521	EMG7331-003Z	FUSE CLIP	
	FT522	EMG7331-003Z	FUSE CLIP	
	FW101	EWR34D-13LS	FLAT WIRE	
	FW401	EWR34D-16LS	FLAT WIRE	
	TB001	EMZ4001-002Z	TAB	
	TB002	EMZ4001-002Z	TAB	
	TH002	QAD0095-4R7Z	POSITIVE THERMISTOR	C
	TW799	EWT015-019	TERMINAL WIRE	

## ■ Electrical Part List (ENB-248)

△	Item	Parts Number	Description	Area
		I. C. S		
	IC231	HA12136A	I. C (MONO-ANALOG)	
	IC901	HD404719A71FS	I. C (MICRO-COMPUTER)	
	IC902	MN172412JAAW	I. C (MICRO-COMPUTER)	
	IC903	XR1099CP	I. C (MONO-ANALOG)	
	IC904	GP1U271X	INFRARED DETECT UNIT	
		DIODES		
	D041	1SS133	SI. DIODE	
	D231	1SR35-100	SI. DIODE	
	D232	SLR-342MCA47	L. E. D.	
	D233	SLR-342MCA47	L. E. D.	
	D234	SLR-342MCA47	L. E. D.	
	D235	SLR-342MCA47	L. E. D.	
	D236	SLR-342MCA47	L. E. D.	
	D237	SLR-342MCA47	L. E. D.	
	D801	MTZ2. 4JB	ZENER DIODE	
	D802	SLR-342VC3F	L. E. D.	
	D803	SLR-342VC3F	L. E. D.	
	D804	SLR-342VC3F	L. E. D.	
	D805	SLR-342VC3F	L. E. D.	
	D806	SLR-342VC3F	L. E. D.	
	D901	1SS119	SI. DIODE	
	D902	1SS133	SI. DIODE	
	D904	SLR-342DCA47	L. E. D.	
	D905	SLR-342MCA47	L. E. D.	
	D906	SLR-342MCA47	L. E. D.	
	D907	SLR-342MCA47	L. E. D.	
	D908	SLR-342MCA47	L. E. D.	
	D909	SLR-342MCA47	L. E. D.	
	D910	SLR-342MCA47	L. E. D.	
	D911	SLR-342MCA47	L. E. D.	
	D912	SLR-342MCA47	L. E. D.	
	D917	SLR-342MCA47	L. E. D.	
	D918	SLR-342MCA47	L. E. D.	
	D919	SLR-342MCA47	L. E. D.	
	D920	1SS133	SI. DIODE	
	D921	1SS133	SI. DIODE	
	D922	1SS133	SI. DIODE	
	D923	MTZ5. 6JC	ZENER DIODE	
	D924	MTZ5. 6JC	ZENER DIODE	
	D925	MTZ5. 6JC	ZENER DIODE	
	D932	1SS133	SI. DIODE	
	D933	1SS133	SI. DIODE	
	D934	1SS133	SI. DIODE	
	D935	1SS133	SI. DIODE	
	D941	MTZ5. 1JB	ZENER DIODE	
		TRANSISTORS		
	Q231	2SA934 (Q, R)	SI. TRANSISTOR	
	Q232	DTC123YS	SI. TRANSISTOR	
	Q233	2SA934 (Q, R)	SI. TRANSISTOR	
	Q234	DTC123YS	SI. TRANSISTOR	
	Q235	2SA933S (RS)	SI. TRANSISTOR	
	Q236	KRC107M-T	DIGITAL TRANSISTOR	
	Q237	KRC107M-T	DIGITAL TRANSISTOR	
	Q901	KRC102M-T	DIGITAL TRANSISTOR	
	Q902	KRC102M-T	DIGITAL TRANSISTOR	
	Q903	KRC102M-T	DIGITAL TRANSISTOR	
	Q904	KRC102M-T	DIGITAL TRANSISTOR	
	Q921	KRC107M-T	DIGITAL TRANSISTOR	
	Q922	DTC114ES	DIGITAL TRANSISTOR	
	Q923	DTC114ES	DIGITAL TRANSISTOR	
	Q924	DTC114ES	DIGITAL TRANSISTOR	
	Q925	DTC114ES	DIGITAL TRANSISTOR	
		CAPACITORS		
	C051	QFLB1HJ-223	0. 022MF 50V MYLAR CAP.	
	C052	QFLB1HJ-223	0. 022MF 50V MYLAR CAP.	
	C053	QCXB1CM-222Y	2200PF 16V CER. CAP.	
	C054	QCXB1CM-222Y	2200PF 16V CER. CAP.	
	C055	QFLB1HJ-393	0. 039MF 50V MYLAR CAP.	
	C056	QFLB1HJ-393	0. 039MF 50V MYLAR CAP.	
	C233	QETC1HM-225ZM	2. 2MF 50V E. CAP.	
	C234	QETC1HM-225ZM	2. 2MF 50V E. CAP.	
	C235	QETC1HM-225ZM	2. 2MF 50V E. CAP.	
	C236	QETC1HM-225ZM	2. 2MF 50V E. CAP.	
	C237	QETC1HM-225ZM	2. 2MF 50V E. CAP.	
	C238	QETC1HM-225ZM	2. 2MF 50V E. CAP.	

△	Item	Parts Number	Description	Area
	C239	QETC1HM-225ZM	2. 2MF 50V E. CAP.	
	C240	QCBBIHK-221Y	220PF 50V CER. CAP.	
	C241	QCBBIHK-221Y	220PF 50V CER. CAP.	
	C242	EETB1HM-475E	4. 7MF 50V E. CAP.	
	C243	QFV81HJ-224	0. 22MF 50V THIN FILM CAP.	
	C244	QFV81HJ-224	0. 22MF 50V THIN FILM CAP.	
	C245	QCBBIHK-561Y	560PF 50V CER. CAP.	
	C246	QCBBIHK-561Y	560PF 50V CER. CAP.	
	C247	EETB1CM-476	47MF 16V E. CAP.	
	C251	QETN1CM-107Z	100MF 16V E. CAP.	
	C801	QCBBIHK-471Y	470PF 50V CER. CAP.	
	C802	QCBBIHK-471Y	470PF 50V CER. CAP.	
	C901	EETB1AM-107E	100MF 10V E. CAP.	
	C902	QCZO205-155	1. 5MF 25V C. CAP.	
	C903	QEADQHZ-479ZM	47000MF E. CAP.	
	C904	QCHB1EZ-223	0. 022MF 25V CER. CAP.	
	C905	QER50JM-107	100MF 6. 3V AL E. CAP.	
	C910	QCT26CH-330	33PF 50V CER. CAP.	
	C911	QEADQHZ-479ZM	47000MF E. CAP.	
	C912	EETB1AM-476E	47MF 10V E. CAP.	
	C914	QCZO205-155	1. 5MF 25V C. CAP.	
	C915	QCVB1CM-103Y	0. 01MF 16V CER. CAP.	
	C916	QER51HM-474G	0. 47MF 50V AL E. CAP.	
	C921	QER50JM-107	100MF 6. 3V AL E. CAP.	
	C922	QER50JM-107	100MF 6. 3V AL E. CAP.	
	C923	QCBBIHK-102	1000PF 50V CER. CAP.	
	TC902	ENZ1003-015	0. 1MF TRIMMER CAPA	
		RESISTORS		
	R047	QRD161J-333	33K 1/6W CARBON RES.	
	R048	QRD161J-333	33K 1/6W CARBON RES.	
	R049	QRD161J-102	1K 1/6W CARBON RES.	
	R051	QRD14CJ-4R7SX	4. 7 1/4W UNF. CARBON R	
	R052	QRD14CJ-4R7SX	4. 7 1/4W UNF. CARBON R	
	R235	QRD167J-153	15K 1/6W CARBON RES.	
	R236	QRD167J-153	15K 1/6W CARBON RES.	
	R237	QRD161J-681	680 1/6W CARBON RES.	
	R238	QRD161J-681	680 1/6W CARBON RES.	
△	R239	QRD14CJ-220S	22 1/4W UNF. CARBON R	
	R240	QRD161J-103	10K 1/6W CARBON RES.	
	R241	QRD161J-183	18K 1/6W CARBON RES.	
	R242	QRD161J-183	18K 1/6W CARBON RES.	
	R245	QRD167J-751	750 1/6W CARBON RES.	
	R246	QRD167J-751	750 1/6W CARBON RES.	
	R247	QRD161J-471	470 1/6W CARBON RES.	
△	R248	QRX022J-3R3A	3. 3 2W METAL FILM R	
	R249	QRD161J-103	10K 1/6W CARBON RES.	
	R250	QRD161J-103	10K 1/6W CARBON RES.	
	R251	QRD161J-103	10K 1/6W CARBON RES.	
	R255	QRD167J-751	750 1/6W CARBON RES.	
	R256	QRD167J-751	750 1/6W CARBON RES.	
	R257	QRD161J-471	470 1/6W CARBON RES.	
△	R258	QRX022J-3R3A	3. 3 2W METAL FILM R	
	R259	QRD161J-224	220K 1/6W CARBON RES.	
	R260	QRD161J-103	10K 1/6W CARBON RES.	
	R261	QRD161J-473	47K 1/6W CARBON RES.	
	R262	QRD161J-273	27K 1/6W CARBON RES.	
	R263	QRD161J-102	1K 1/6W CARBON RES.	
	R264	QRD161J-103	10K 1/6W CARBON RES.	
	R265	QRD161J-103	10K 1/6W CARBON RES.	
	R266	QRD161J-103	10K 1/6W CARBON RES.	
	R267	QRD161J-103	10K 1/6W CARBON RES.	
	R268	QRD161J-221	220 1/6W CARBON RES.	
	R269	QRD161J-221	220 1/6W CARBON RES.	
	R801	QRD167J-431	430 1/6W CARBON RES.	
	R802	QRD167J-431	430 1/6W CARBON RES.	
	R803	QRD161J-561	560 1/6W CARBON RES.	
	R804	QRD167J-751	750 1/6W CARBON RES.	
	R805	QRD161J-132	1. 3K 1/6W CARBON RES.	
	R806	QRD161J-222	2. 2K 1/6W CARBON RES.	
	R807	QRD167J-431	430 1/6W CARBON RES.	
	R808	QRD167J-431	430 1/6W CARBON RES.	
	R809	QRD161J-561	560 1/6W CARBON RES.	
	R810	QRD167J-751	750 1/6W CARBON RES.	
	R811	QRD161J-132	1. 3K 1/6W CARBON RES.	
	R812	QRD161J-331	330 1/6W CARBON RES.	
	R813	QRD161J-331	330 1/6W CARBON RES.	

## ■ Electrical Part List (ENB-248)

△	Item	Parts Number	Description	Area
	R814	QRD161J-331	330 1/6W CARBON RES.	
	R815	QRD161J-331	330 1/6W CARBON RES.	
	R816	QRD161J-331	330 1/6W CARBON RES.	
	R817	QRD161J-103	10K 1/6W CARBON RES.	
	R818	QRD161J-103	10K 1/6W CARBON RES.	
	R900	QRD161J-103	10K 1/6W CARBON RES.	
	R901	QRD161J-105	1M 1/6W CARBON RES.	
	R902	QRD161J-103	10K 1/6W CARBON RES.	
	R903	QRD161J-220	22 1/6W CARBON RES.	
	R904	QRD161J-222	2.2K 1/6W CARBON RES.	
	R905	QRD161J-103	10K 1/6W CARBON RES.	
	R906	QRD161J-221	220 1/6W CARBON RES.	
	R907	QRD161J-221	220 1/6W CARBON RES.	
	R915	QRD161J-222	2.2K 1/6W CARBON RES.	
	R918	QRD167J-431	430 1/6W CARBON RES.	
	R919	QRD167J-431	430 1/6W CARBON RES.	
	R920	QRD161J-561	560 1/6W CARBON RES.	
	R921	QRD167J-751	750 1/6W CARBON RES.	
	R922	QRD161J-132	1.3K 1/6W CARBON RES.	
	R923	QRD161J-222	2.2K 1/6W CARBON RES.	
	R924	QRD161J-512	5.1K 1/6W CARBON RES.	
	R925	QRD167J-431	430 1/6W CARBON RES.	
	R926	QRD167J-431	430 1/6W CARBON RES.	
	R927	QRD161J-561	560 1/6W CARBON RES.	
	R928	QRD167J-751	750 1/6W CARBON RES.	
	R929	QRD161J-132	1.3K 1/6W CARBON RES.	
	R930	QRD161J-222	2.2K 1/6W CARBON RES.	
	R931	QRD161J-512	5.1K 1/6W CARBON RES.	
	R932	QRD167J-431	430 1/6W CARBON RES.	
	R933	QRD167J-431	430 1/6W CARBON RES.	
	R934	QRD161J-561	560 1/6W CARBON RES.	
	R935	QRD167J-751	750 1/6W CARBON RES.	
	R936	QRD161J-132	1.3K 1/6W CARBON RES.	
	R937	QRD161J-222	2.2K 1/6W CARBON RES.	
	R938	QRD161J-512	5.1K 1/6W CARBON RES.	
	R939	QRD167J-431	430 1/6W CARBON RES.	
	R944	QRD161J-181	180 1/6W CARBON RES.	
	R945	QRD161J-181	180 1/6W CARBON RES.	
	R946	QRD161J-181	180 1/6W CARBON RES.	
	R947	QRD161J-181	180 1/6W CARBON RES.	
	R948	QRD161J-181	180 1/6W CARBON RES.	
	R949	QRD161J-181	180 1/6W CARBON RES.	
	R950	QRD161J-181	180 1/6W CARBON RES.	
	R951	QRD161J-181	180 1/6W CARBON RES.	
	R952	QRD161J-181	180 1/6W CARBON RES.	
	R957	QRD161J-181	180 1/6W CARBON RES.	
	R958	QRD161J-181	180 1/6W CARBON RES.	
	R959	QRD161J-181	180 1/6W CARBON RES.	
	R960	QRD161J-102	1K 1/6W CARBON RES.	
	R961	QRD161J-221	220 1/6W CARBON RES.	
	R962	QRD161J-102	1K 1/6W CARBON RES.	
	R963	QRD161J-222	2.2K 1/6W CARBON RES.	
	R964	QRD161J-221	220 1/6W CARBON RES.	
	R965	QRD161J-221	220 1/6W CARBON RES.	
	R966	QRD161J-221	220 1/6W CARBON RES.	
	R967	QRD161J-221	220 1/6W CARBON RES.	
	R968	QRD161J-221	220 1/6W CARBON RES.	
	R970	QRD167J-223	22K 1/6W CARBON RES.	
	R971	QRD161J-472	4.7K 1/6W CARBON RES.	
	R972	QRD161J-472	4.7K 1/6W CARBON RES.	
	R973	QRD161J-472	4.7K 1/6W CARBON RES.	
	R974	QRD161J-472	4.7K 1/6W CARBON RES.	
	R975	QRD161J-473	47K 1/6W CARBON RES.	
	R976	QRD161J-104	100K 1/6W CARBON RES.	
	R977	QRD161J-104	100K 1/6W CARBON RES.	
	R978	QRD161J-104	100K 1/6W CARBON RES.	
	R979	QRD161J-104	100K 1/6W CARBON RES.	
	R980	QRD167J-562	5.6K 1/6W CARBON RES.	
	R981	QRD161J-331	330 1/6W CARBON RES.	
	R982	QRD161J-103	10K 1/6W CARBON RES.	
	R983	QRD161J-103	10K 1/6W CARBON RES.	
	R984	QRD161J-103	10K 1/6W CARBON RES.	
	R985	QRD167J-152	1.5K 1/6W CARBON RES.	
	R986	QRD161J-331	330 1/6W CARBON RES.	
	R987	QRD161J-103	10K 1/6W CARBON RES.	
	R989	QRD161J-103	10K 1/6W CARBON RES.	

△	Item	Parts Number	Description	Area
	RA901	QRB069J-222	2.2K 1/10W NETWORK RES.	
	VR233	QVPA603-103A	10K TRIMMER RES.	
		OTHERS		
		EMW10685-002	PRINTED BOARD	
	J081	EMB10TV-401AJ3	SPEAKER TERMINAL	
	J082	EMN00TV-119AJ4	PIN JACK	
	J801	QMS3R80-EE0S	HEADPHONE JACK	
	K801	ENZ8101-007	INDUCTOR	
	S801	ESP0001-023M	TACT SWITCH	
	S802	ESP0001-023M	TACT SWITCH	
	S803	ESP0001-023M	TACT SWITCH	
	S804	ESP0001-023M	TACT SWITCH	
	S805	ESP0001-023M	TACT SWITCH	
	S806	ESP0001-023M	TACT SWITCH	
	S807	ESP0001-023M	TACT SWITCH	
	S808	ESP0001-023M	TACT SWITCH	
	S809	ESP0001-023M	TACT SWITCH	
	S810	ESP0001-023M	TACT SWITCH	
	S811	ESP0001-023M	TACT SWITCH	
	S812	ESP0001-023M	TACT SWITCH	
	S813	ESP0001-023M	TACT SWITCH	
	S901	ESP0001-023M	TACT SWITCH	
	S902	ESP0001-023M	TACT SWITCH	
	S903	ESP0001-023M	TACT SWITCH	
	S904	ESP0001-023M	TACT SWITCH	
	S905	ESP0001-023M	TACT SWITCH	
	S906	ESP0001-023M	TACT SWITCH	
	S907	ESP0001-023M	TACT SWITCH	
	S908	ESP0001-023M	TACT SWITCH	
	S909	ESP0001-023M	TACT SWITCH	
	S910	ESP0001-023M	TACT SWITCH	
	S911	ESP0001-023M	TACT SWITCH	
	S912	ESP0001-023M	TACT SWITCH	
	S913	ESP0001-023M	TACT SWITCH	
	S914	ESP0001-023M	TACT SWITCH	
	S915	ESP0001-023M	TACT SWITCH	
	S916	ESP0001-023M	TACT SWITCH	
	S917	ESP0001-023M	TACT SWITCH	
	S918	ESP0001-023M	TACT SWITCH	
	S919	ESP0001-023M	TACT SWITCH	
	S920	ESP0001-023M	TACT SWITCH	
	S921	ESP0001-023M	TACT SWITCH	
	S922	ESP0001-023M	TACT SWITCH	
	S923	ESP0001-023M	TACT SWITCH	
	S924	ESP0001-023M	TACT SWITCH	
	S925	ESP0001-023M	TACT SWITCH	
	S926	ESP0001-023M	TACT SWITCH	
	X901	ECX0004-194KM	CERAMIC RESONATOR	
	X902	ECX0006-000KNJ	CRYSTAL	
	BK901	E309782-002SM	P. W. BOARD BRACKET	
	BK902	E310200-001SM	L. E. D. HOLDER	
	CN015	EMV5163-006R	CONNECT TERMINAL	
	CN101	EMV7163-012	CONNECT TERMINAL	
	CN121	EWS26C-A408	FLAT WIRE ASSY	
	CN301	EMV7172-014R	CONNECT TERMINAL	
	CN302	EMV7172-014R	CONNECT TERMINAL	
	CN313	VMC0314-S14	CONNECT TERMINAL	
	CN314	VMC0314-S08	CONNECT TERMINAL	
	CN401	VMC0163-R25	CONNECT TERMINAL	
	CN403	EMV7160-016	CONNECT TERMINAL	
	D1901	QLF0012-001	FLUORESCENT DISPLAY TUBE	
	FS901	E3400-439	FELT SPACER	
	FS902	E3400-439	FELT SPACER	
	FW401	VWSC12-083K3K	FLAT WIRE ASSY	
	FW402	EWR33D-25LS	FLAT WIRE	
	JS801	QSJ4003-E01	PUSH SWITCH	
	RY001	ESK7D24-213R	RELAY	
	SP901	VYH7653-001	LEAF SPRING	
	SP902	VYH7653-001	LEAF SPRING	
	TW001	EWT015-001	TERMINAL WIRE	
	TW003	EWT015-018	TERMINAL WIRE	
	TW333	QWE353-144K4K	WIRE	

## ■ Electrical Parts List (ENG-136)

△	Item	Parts Number	Description	Area
		I. C. S		
	IC301	MN173222JAAX1	I. C.	
	IC302	BA15218N	I. C (MONO-ANALOG)	
	IC303	BA15218N	I. C (MONO-ANALOG)	
	IC304	BA3126N	I. C (MONO-ANALOG)	
	IC305	HA12206NT	I. C (MONO-ANALOG)	
	IC401	TDA7439	I. C (M)	
	IC402	BA15218	I. C (MONO-ANALOG)	
	IC403	BA15218	I. C (MONO-ANALOG)	
	IC405	BA15218	I. C (MONO-ANALOG)	
	IC407	BA15218	I. C (MONO-ANALOG)	
		DIODES		
	D201	1SS133	SI. DIODE	
	D202	1SS133	SI. DIODE	
	D203	1SS133	SI. DIODE	
	D290	1SS133	SI. DIODE	
	D305	MTZ7.5JC	ZENER DIODE	
	D306	MTZ7.5JC	ZENER DIODE	
	D307	1SS133	SI. DIODE	
	D308	1SS133	SI. DIODE	
	D481	1SS133	SI. DIODE	
	D482	1SS133	SI. DIODE	
		TRANSISTORS		
	Q201	KRC107M-T	DIGITAL TRANSISTOR	
	Q321	2SD2144S (VW)	SI. TRANSISTOR	
	Q322	2SD2144S (VW)	SI. TRANSISTOR	
	Q323	KRA107M-T	DIGITAL TRANSISTOR	
	Q324	2SD2144S (VW)	SI. TRANSISTOR	
	Q325	2SD2144S (VW)	SI. TRANSISTOR	
	Q326	2SC1740S (R. S)	SI. TRANSISTOR	
	Q327	2SC1740S (R. S)	SI. TRANSISTOR	
	Q328	2SC1740S (R. S)	SI. TRANSISTOR	
	Q329	2SC1740S (R. S)	SI. TRANSISTOR	
	Q341	KRC107M-T	DIGITAL TRANSISTOR	
	Q342	KRC107M-T	DIGITAL TRANSISTOR	
	Q343	KRC107M-T	DIGITAL TRANSISTOR	
	Q401	2SD2144S (VW)	SI. TRANSISTOR	
	Q402	2SD2144S (VW)	SI. TRANSISTOR	
	Q403	KRA102M-T	DIGITAL TRANSISTOR	
	Q481	2SD2144S (VW)	SI. TRANSISTOR	
	Q482	2SD2144S (VW)	SI. TRANSISTOR	
	Q483	KRA102M-T	DIGITAL TRANSISTOR	
	Q491	KRC102M-T	DIGITAL TRANSISTOR	
	Q492	2SB1565 (E. F)	SI. TRANSISTOR	
		CAPACITORS		
	C201	QETN1AM-227Z	220MF 10V E. CAP.	
	C202	QCZ0205-155	1.5MF 25V C. CAP.	
	C203	QCVB1CM-103Y	0.01MF 16V CER. CAP.	
	C205	QCBBIHK-221Y	220PF 50V CER. CAP.	
	C206	QCBBIHK-221Y	220PF 50V CER. CAP.	
	C211	QCVB1CM-103Y	0.01MF 16V CER. CAP.	
	C231	QFLB1HJ-104	0.1MF 50V MYLAR CAP.	
	C232	QFLB1HJ-104	0.1MF 50V MYLAR CAP.	
	C305	QCBBIHK-101Y	100PF 50V CER. CAP.	
	C306	QCBBIHK-101Y	100PF 50V CER. CAP.	
	C315	EETB1HM-105E	1MF 50V E. CAP.	
	C316	EETB1HM-105E	1MF 50V E. CAP.	
	C317	EETB1EM-106E	10MF 25V E. CAP.	
	C318	QETN1CM-107Z	100MF 16V E. CAP.	
	C320	QFLB1HJ-682	6800PF 50V MYLAR CAP.	
	C321	QFLB1HJ-332	3300PF 50V MYLAR CAP.	
	C322	QFLB1HJ-332	3300PF 50V MYLAR CAP.	
	C323	QFLB1HJ-183	0.018MF 50V MYLAR CAP.	
	C324	QFP31HG-472	4700PF 50V POLYPROPY. FILM	
	C325	QCBBIHK-101Y	100PF 50V CER. CAP.	
	C326	QCBBIHK-101Y	100PF 50V CER. CAP.	
	C335	QCF21HP-472	4700PF 50V CER. CAP.	
	C336	QCF21HP-472	4700PF 50V CER. CAP.	
	C339	EETB1CM-476	47MF 16V E. CAP.	
	C340	EETB1CM-476	47MF 16V E. CAP.	

△	Item	Parts Number	Description	Area
	C341	QFLB1HJ-472	4700PF 50V MYLAR CAP.	
	C342	QFLB1HJ-472	4700PF 50V MYLAR CAP.	
	C343	QETC1HM-225ZM	2.2MF 50V E. CAP.	
	C344	QETC1HM-225ZM	2.2MF 50V E. CAP.	
	C345	QFLB1HJ-104	0.1MF 50V MYLAR CAP.	
	C346	QFLB1HJ-104	0.1MF 50V MYLAR CAP.	
	C347	QETC1HM-225ZM	2.2MF 50V E. CAP.	
	C348	QETC1HM-225ZM	2.2MF 50V E. CAP.	
	C351	QCBBIHK-821Y	820PF 50V CER. CAP.	
	C352	QETN1HM-474Z	0.47MF 50V AL E. CAP.	
	C353	QETN1HM-476Z	47MF 50V E. CAP.	
	C365	QETC1HM-225ZM	2.2MF 50V E. CAP.	
	C366	QETC1HM-225ZM	2.2MF 50V E. CAP.	
	C367	QFLB1HJ-822	8200PF 50V MYLAR CAP.	
	C368	QFLB1HJ-822	8200PF 50V MYLAR CAP.	
	C369	EETB1AM-107E	100MF 10V E. CAP.	
	C370	EETB1AM-107E	100MF 10V E. CAP.	
	C371	QETC1HM-225ZM	2.2MF 50V E. CAP.	
	C372	QETC1HM-225ZM	2.2MF 50V E. CAP.	
	C373	EETB1CM-476	47MF 16V E. CAP.	
	C374	QETC1EM-476ZM	47MF 25V E. CAP.	
	C375	QCBBIHK-101Y	100PF 50V CER. CAP.	
	C376	QCBBIHK-101Y	100PF 50V CER. CAP.	
	C377	QCXB1CM-122	1200PF 16V POLYPROPY. FILM	
	C378	QCXB1CM-122	1200PF 16V POLYPROPY. FILM	
	C379	QCBBIHK-331Y	330PF 50V CER. CAP.	
	C380	QCBBIHK-331Y	330PF 50V CER. CAP.	
	C381	EETB1CM-476	47MF 16V E. CAP.	
	C385	QFLB1HJ-822	8200PF 50V MYLAR CAP.	
	C386	QFLB1HJ-822	8200PF 50V MYLAR CAP.	
	C387	EETB1AM-107E	100MF 10V E. CAP.	
	C388	EETB1AM-107E	100MF 10V E. CAP.	
	C389	QETC1HM-225ZM	2.2MF 50V E. CAP.	
	C390	QETC1HM-225ZM	2.2MF 50V E. CAP.	
	C391	EETB1CM-476	47MF 16V E. CAP.	
	C392	EETB1CM-476	47MF 16V E. CAP.	
	C393	QCS21HJ-101A	100PF 50V CER. CAP.	
	C394	QCS21HJ-101A	100PF 50V CER. CAP.	
	C395	QCXB1CM-152Y	1500PF 16V CER. CAP.	
	C396	QCXB1CM-152Y	1500PF 16V CER. CAP.	
	C397	QCBBIHK-391Y	390PF 50V CER. CAP.	
	C398	QCBBIHK-391Y	390PF 50V CER. CAP.	
	C401	QFLB1HJ-472	4700PF 50V MYLAR CAP.	
	C402	QFLB1HJ-472	4700PF 50V MYLAR CAP.	
	C403	QFLB1HJ-102	1000PF 50V MYLAR CAP.	
	C404	QFLB1HJ-102	1000PF 50V MYLAR CAP.	
	C405	EETB1EM-106E	10MF 25V E. CAP.	
	C406	EETB1EM-106E	10MF 25V E. CAP.	
	C407	EETB1EM-106E	10MF 25V E. CAP.	
	C408	EETB1EM-106E	10MF 25V E. CAP.	
	C411	EETB1EM-106E	10MF 25V E. CAP.	
	C412	EETB1EM-106E	10MF 25V E. CAP.	
	C413	QCBBIHK-471Y	470PF 50V CER. CAP.	
	C414	QCBBIHK-471Y	470PF 50V CER. CAP.	
	C415	EETB1EM-106E	10MF 25V E. CAP.	
	C416	EETB1EM-106E	10MF 25V E. CAP.	
	C417	EETB1EM-106E	10MF 25V E. CAP.	
	C418	EETB1EM-106E	10MF 25V E. CAP.	
	C419	EETB1EM-106E	10MF 25V E. CAP.	
	C420	QETC1EM-476ZM	47MF 25V E. CAP.	
	C421	QFLB1HJ-104	0.1MF 50V MYLAR CAP.	
	C422	QFLB1HJ-104	0.1MF 50V MYLAR CAP.	
	C423	QFLB1HJ-104	0.1MF 50V MYLAR CAP.	
	C424	QFLB1HJ-104	0.1MF 50V MYLAR CAP.	
	C425	QFLB1HJ-183	0.018MF 50V MYLAR CAP.	
	C426	QFLB1HJ-183	0.018MF 50V MYLAR CAP.	
	C427	QFLB1HJ-223	0.022MF 50V MYLAR CAP.	
	C428	QFLB1HJ-223	0.022MF 50V MYLAR CAP.	
	C429	QFLB1HJ-562	5600PF 50V MYLAR CAP.	
	C430	QFLB1HJ-562	5600PF 50V MYLAR CAP.	

## ■ Electrical Parts List (ENC-136)

△	Item	Parts Number	Description	Area
	C431	QETC1HM-225ZM	2.2MF 50V E. CAP.	
	C432	QETC1HM-225ZM	2.2MF 50V E. CAP.	
	C433	EETB1HM-105E	1MF 50V E. CAP.	
	C434	EETB1HM-105E	1MF 50V E. CAP.	
	C435	EETB1EM-106E	10MF 25V E. CAP.	
	C436	EETB1EM-106E	10MF 25V E. CAP.	
	C443	EETB1EM-106E	10MF 25V E. CAP.	
	C444	EETB1EM-106E	10MF 25V E. CAP.	
	C445	QCBB1HK-101Y	100PF 50V CER. CAP.	
	C446	QCBB1HK-101Y	100PF 50V CER. CAP.	
	C447	EETB1EM-106E	10MF 25V E. CAP.	
	C448	EETB1EM-106E	10MF 25V E. CAP.	
	C453	EETB1EM-106E	10MF 25V E. CAP.	
	C454	QCBB1HK-101Y	100PF 50V CER. CAP.	
	C455	EETB1EM-106E	10MF 25V E. CAP.	
	C471	QCBB1HK-101Y	100PF 50V CER. CAP.	
	C472	QCBB1HK-101Y	100PF 50V CER. CAP.	
	C473	QETC1EM-476ZM	47MF 25V E. CAP.	
	C474	QETC1EM-476ZM	47MF 25V E. CAP.	
	C475	EETB1EM-106E	10MF 25V E. CAP.	
	C476	EETB1EM-106E	10MF 25V E. CAP.	
	C477	EETB1HM-475E	4.7MF 50V E. CAP.	
	C481	QCBB1HK-221Y	220PF 50V CER. CAP.	
	C482	QCBB1HK-221Y	220PF 50V CER. CAP.	
	C483	QCXB1CM-222Y	2200PF 16V CER. CAP.	
	C484	QCBB1HK-101Y	100PF 50V CER. CAP.	
	C489	QETB1CM-476	47MF 16V AL E. CAP.	
	C490	QETB1CM-476	47MF 16V AL E. CAP.	
	C493	QFLB1HJ-104	0.1MF 50V MYLAR CAP.	
	C494	QFLB1HJ-104	0.1MF 50V MYLAR CAP.	
	C495	QFLB1HJ-104	0.1MF 50V MYLAR CAP.	
	C496	QFLB1HJ-104	0.1MF 50V MYLAR CAP.	
		RESISTORS		
	R202	QRD161J-102	1K 1/6W CARBON RES.	
	R203	QRD161J-102	1K 1/6W CARBON RES.	
	R204	QRD161J-102	1K 1/6W CARBON RES.	
	R205	QRD161J-102	1K 1/6W CARBON RES.	
	R206	QRD161J-103	10K 1/6W CARBON RES.	
	R207	QRD161J-103	10K 1/6W CARBON RES.	
	R208	QRD161J-472	4.7K 1/6W CARBON RES.	
	R209	QRD167J-223	22K 1/6W CARBON RES.	
	R211	QRD161J-103	10K 1/6W CARBON RES.	
	R213	QRD161J-472	4.7K 1/6W CARBON RES.	
	R214	QRD161J-103	10K 1/6W CARBON RES.	
	R217	QRD161J-103	10K 1/6W CARBON RES.	
	R218	QRD161J-221	220 1/6W CARBON RES.	
	R231	QRD161J-183	18K 1/6W CARBON RES.	
	R232	QRD161J-183	18K 1/6W CARBON RES.	
	R233	QRD167J-153	15K 1/6W CARBON RES.	
	R234	QRD167J-153	15K 1/6W CARBON RES.	
	R271	QRD161J-104	100K 1/6W CARBON RES.	
	R272	QRD161J-104	100K 1/6W CARBON RES.	
	R280	QRD161J-221	220 1/6W CARBON RES.	
	R281	QRD161J-224	220K 1/6W CARBON RES.	
	R282	QRD161J-224	220K 1/6W CARBON RES.	
	R283	QRD161J-100	10 1/6W CARBON RES.	
	R284	QRD161J-100	10 1/6W CARBON RES.	
	R285	QRD161J-393	39K 1/6W CARBON RES.	
	R286	QRD161J-393	39K 1/6W CARBON RES.	
	R287	QRD140J-6R8SX	6.8 1/4W UNF. CARBON R	
△	R288	QRD140J-100SX	10 1/4W UNF. CARBON R	
	R290	QRD167J-332	3.3K 1/6W CARBON RES.	
	R292	QRD161J-181	180 1/6W CARBON RES.	
	R293	QRD167J-511	510 1/6W CARBON RES.	
	R294	QRD161J-561	560 1/6W CARBON RES.	
	R296	QRD161J-104	100K 1/6W CARBON RES.	
	R297	QRD161J-222	2.2K 1/6W CARBON RES.	
	R335	QRD161J-102	1K 1/6W CARBON RES.	
	R336	QRD161J-102	1K 1/6W CARBON RES.	
	R337	QRD161J-102	1K 1/6W CARBON RES.	
	R338	QRD161J-102	1K 1/6W CARBON RES.	
	R339	QRD161J-393	39K 1/6W CARBON RES.	
	R340	QRD161J-393	39K 1/6W CARBON RES.	
	R341	QRD167J-272	2.7K 1/6W CARBON RES.	
	R342	QRD167J-272	2.7K 1/6W CARBON RES.	
	R343	QRD167J-223	22K 1/6W CARBON RES.	
	R344	QRD161J-563	56K 1/6W CARBON RES.	
	R345	QRD161J-184	180K 1/6W CARBON RES.	
	R346	QRD161J-105	1M 1/6W CARBON RES.	
	R347	QRD161J-221	220 1/6W CARBON RES.	
	R348	QRD161J-221	220 1/6W CARBON RES.	
	R349	QRD161J-102	1K 1/6W CARBON RES.	
	R351	QRD161J-472	4.7K 1/6W CARBON RES.	
	R352	QRD161J-472	4.7K 1/6W CARBON RES.	
	R353	QRD167J-223	22K 1/6W CARBON RES.	
	R354	QRD167J-223	22K 1/6W CARBON RES.	
	R355	QRD161J-103	10K 1/6W CARBON RES.	
	R356	QRD161J-103	10K 1/6W CARBON RES.	
	R357	QRD167J-223	22K 1/6W CARBON RES.	
	R358	QRD167J-223	22K 1/6W CARBON RES.	
	R359	QRD161J-103	10K 1/6W CARBON RES.	
	R360	QRD161J-103	10K 1/6W CARBON RES.	
	R361	QRD167J-562	5.6K 1/6W CARBON RES.	
	R362	QRD167J-562	5.6K 1/6W CARBON RES.	
	R367	QRD161J-224	220K 1/6W CARBON RES.	
	R368	QRD161J-224	220K 1/6W CARBON RES.	
	R371	QRD161J-163	16K 1/6W CARBON RES.	
	R372	QRD161J-163	16K 1/6W CARBON RES.	
	R377	QRD161J-221	220 1/6W CARBON RES.	
	R378	QRD161J-221	220 1/6W CARBON RES.	
	R381	QRD161J-221	220 1/6W CARBON RES.	
	R382	QRD161J-221	220 1/6W CARBON RES.	
	R385	QRD161J-224	220K 1/6W CARBON RES.	
	R386	QRD161J-224	220K 1/6W CARBON RES.	
	R391	QRD161J-163	16K 1/6W CARBON RES.	
	R392	QRD161J-163	16K 1/6W CARBON RES.	
	R401	QRD161J-222	2.2K 1/6W CARBON RES.	
	R402	QRD161J-222	2.2K 1/6W CARBON RES.	
	R403	QRD161J-222	2.2K 1/6W CARBON RES.	
	R404	QRD161J-222	2.2K 1/6W CARBON RES.	
	R405	QRD167J-152	1.5K 1/6W CARBON RES.	
	R406	QRD167J-152	1.5K 1/6W CARBON RES.	
	R407	QRD167J-562	5.6K 1/6W CARBON RES.	
	R408	QRD167J-562	5.6K 1/6W CARBON RES.	
	R409	QRD161J-472	4.7K 1/6W CARBON RES.	
	R410	QRD161J-472	4.7K 1/6W CARBON RES.	
	R411	QRD167J-562	5.6K 1/6W CARBON RES.	
	R412	QRD167J-562	5.6K 1/6W CARBON RES.	
	R413	QRD161J-102	1K 1/6W CARBON RES.	
	R414	QRD161J-102	1K 1/6W CARBON RES.	
	R415	QRD161J-823	82K 1/6W CARBON RES.	
	R416	QRD161J-823	82K 1/6W CARBON RES.	
	R417	QRD167J-562	5.6K 1/6W CARBON RES.	
	R418	QRD167J-562	5.6K 1/6W CARBON RES.	
	R419	QRD167J-272	2.7K 1/6W CARBON RES.	
	R420	QRD167J-272	2.7K 1/6W CARBON RES.	
	R421	QRD161J-104	100K 1/6W CARBON RES.	
	R422	QRD161J-104	100K 1/6W CARBON RES.	
	R431	QRD161J-104	100K 1/6W CARBON RES.	
	R432	QRD161J-104	100K 1/6W CARBON RES.	
	R433	QRD167J-562	5.6K 1/6W CARBON RES.	
	R434	QRD167J-562	5.6K 1/6W CARBON RES.	
	R435	QRD161J-392	3.9K 1/6W CARBON RES.	
	R436	QRD161J-392	3.9K 1/6W CARBON RES.	
	R437	QRD161J-472	4.7K 1/6W CARBON RES.	
	R438	QRD161J-472	4.7K 1/6W CARBON RES.	
	R439	QRD161J-432	4.3K 1/6W CARBON RES.	
	R440	QRD161J-432	4.3K 1/6W CARBON RES.	
	R441	QRD161J-104	100K 1/6W CARBON RES.	
	R442	QRD161J-104	100K 1/6W CARBON RES.	

## ■ Electrical Parts List (ENC-136)

△	Item	Parts Number	Description	Area
	R445	QRD161J-303Y	30K 1/6W CARBON RES.	
	R446	QRD161J-303Y	30K 1/6W CARBON RES.	
	R447	QRD167J-153	15K 1/6W CARBON RES.	
	R448	QRD161J-104	100K 1/6W CARBON RES.	
	R453	QRD161J-104	100K 1/6W CARBON RES.	
	R454	QRD161J-104	100K 1/6W CARBON RES.	
	R455	QRD161J-103	10K 1/6W CARBON RES.	
	R456	QRD161J-103	10K 1/6W CARBON RES.	
	R457	QRD167J-562	5.6K 1/6W CARBON RES.	
	R458	QRD167J-562	5.6K 1/6W CARBON RES.	
	R459	QRD161J-104	100K 1/6W CARBON RES.	
	R460	QRD161J-104	100K 1/6W CARBON RES.	
	R461	QRD161J-221	220 1/6W CARBON RES.	
	R462	QRD161J-221	220 1/6W CARBON RES.	
	R463	QRD161J-103	10K 1/6W CARBON RES.	
	R464	QRD161J-103	10K 1/6W CARBON RES.	
	R465	QRD161J-102	1K 1/6W CARBON RES.	
	R481	QRD161J-222	2.2K 1/6W CARBON RES.	
	R482	QRD161J-222	2.2K 1/6W CARBON RES.	
	R483	QRD161J-221	220 1/6W CARBON RES.	
	R484	QRD161J-221	220 1/6W CARBON RES.	
	R485	QRD161J-103	10K 1/6W CARBON RES.	
	R486	QRD161J-103	10K 1/6W CARBON RES.	
	R491	QRD161J-471	470 1/6W CARBON RES.	
	R492	QRD161J-103	10K 1/6W CARBON RES.	
	R493	QRD167J-113	11K 1/6W CARBON RES.	
	R494	QRD167J-113	11K 1/6W CARBON RES.	
	R497	QRD161J-104	100K 1/6W CARBON RES.	
	R498	QRD161J-104	100K 1/6W CARBON RES.	
	VR231	QVPA603-503A	50K VARIABLE RES.	
	VR232	QVPA603-503A	50K VARIABLE RES.	
	VR301	QVPA603-102AZA	1K TRIMMER RES.	
	VR302	QVPA603-102AZA	1K TRIMMER RES.	
	VR303	QVPA603-102AZA	1K TRIMMER RES.	
	VR304	QVPA603-102AZA	1K TRIMMER RES.	
	VR305	QVPA603-104A	100K TRIMMER RES.	
	VR306	QVPA603-104A	100K TRIMMER RES.	
	VR307	QVPA603-104A	100K TRIMMER RES.	
	VR308	QVPA603-104A	100K TRIMMER RES.	
	VR309	QVPA603-104A	100K TRIMMER RES.	
	VR310	QVPA603-104A	100K TRIMMER RES.	
		OTHERS		
		EMW10686-002	PRINTED BOARD	
		QWE350-09RR	VINYL WIRE	
	J401	EMN00TV-414AJ2	4P PIN JACK	
	J701	EMV7145-004Z	SOCKET ASSY	
	L301	ENZ6002-012	OSCILLATOR COIL	
	L305	EQL2106-223	INDUCTOR	
	L306	EQL2106-223	INDUCTOR	
	X201	ECX0060-000EM	CERAMIC RESONATOR	
	CN016	EMV5163-010R	CONNECT TERMINAL	
	CN017	EMV5163-009R	CONNECT TERMINAL	
	CN131	EMV5109-012A	MALE CONNECTOR	
	CN311	EMV5172-014B	CONNECT TERMINAL	
	CN312	EMV5172-014B	CONNECT TERMINAL	
	CN322	VMC0163-016	CONNECT TERMINAL	
	CN331	EMV7155-106R	CONNECT TERMINAL	
	CN332	EMV7155-106R	CONNECT TERMINAL	
	CN402	VMC0163-017	CONNECT TERMINAL	
	CN411	VMC0163-025	CONNECT TERMINAL	
	CN412	VMC0163-017	CONNECT TERMINAL	
	CN613	VMC0163-007	CONNECT TERMINAL	
	CN614	VMC0163-011	CONNECT TERMINAL	
	CN811	VMC0163-010	AC CONNECTOR	
	EP003	E409182-001SM	EARTH TERMINAL	
	SP301	VYH7653-001	LEAF SPRING	



## ■ Electrical Parts List (ENN-488)

△	Item	Parts Number	Description	Area
		I. C. S		
	IC601	AN8806SB	I. C (MONO-ANALOG)	
	IC602	BA6897FPW	I. C (MONO-ANALOG)	
	IC603	MN35510-S	I. C (M)	
		DIODES		
	D631	MTZ5.6JB	ZENER DIODE	
		TRANSISTORS		
	Q601	2SA952 (L. K)	SI. TRANSISTOR	
	Q632	2SC2060 (Q. R)	SI. TRANSISTOR	
		CAPACITORS		
	C602	QCZ0205-155	1.5MF 25V C. CAP.	
	C603	QFLB1HJ-104	0.1MF 50V MYLAR CAP.	
	C605	EETB1EM-106E	10MF 25V E. CAP.	
	C606	QCB1HK-102Y	1000PF 50V CER. CAP.	
	C607	QCB1HK-102Y	1000PF 50V CER. CAP.	
	C608	EETB1HM-105E	1MF 50V E. CAP.	
	C609	QCB1HK-101Y	100PF 50V CER. CAP.	
	C610	QFLB1HJ-273	0.027MF 50V MYLAR CAP.	
	C611	QCXB1CM-472Y	4700PF 16V CER. CAP.	
	C612	QCVB1CM-103Y	0.01MF 16V CER. CAP.	
	C613	QCB1HK-331Y	330PF 50V CER. CAP.	
	C614	QFLB1HJ-104	0.1MF 50V MYLAR CAP.	
	C615	QCHB1EZ-223	0.022MF 25V CER. CAP.	
	C616	QCHB1EZ-223	0.022MF 25V CER. CAP.	
	C617	QCHB1EZ-223	0.022MF 25V CER. CAP.	
	C618	QCHB1EZ-223	0.022MF 25V CER. CAP.	
	C619	QCB1HK-271Y	270PF 50V CER. CAP.	
	C620	QCSB1HJ-470	47PF 50V CER. CAP.	
	C621	QCB1HK-102Y	1000PF 50V CER. CAP.	
	C622	QCF21HP-223A	0.022MF 50V CER. CAP.	
	C623	QFLB1HJ-104	0.1MF 50V MYLAR CAP.	
	C625	QCZ0205-155	1.5MF 25V C. CAP.	
	C630	QETN1AM-226ZS	22MF 10V E. CAP.	
	C631	QETN1AM-477Z	470MF 10V E. CAP.	
	C632	QEK61AM-227ZM	220MF 10V AL E. CAP.	
	C636	EETB1AM-107E	100MF 10V E. CAP.	
	C641	QCVB1CM-103Y	0.01MF 16V CER. CAP.	
	C642	QFLB1HJ-103	0.01MF 50V MYLAR CAP.	
	C651	QCSB1HJ-120Y	12PF 50V CER. CAP.	
	C652	QCSB1HJ-120Y	12PF 50V CER. CAP.	
	C653	QCHB1EZ-223	0.022MF 25V CER. CAP.	
	C655	QFV81HJ-104	0.1MF 50V THIN FILM CAP.	
	C661	QCB1HK-471Y	470PF 50V CER. CAP.	
	C662	QFV81HJ-104	0.1MF 50V THIN FILM CAP.	
	C663	QFLB1HJ-223	0.022MF 50V MYLAR CAP.	
	C664	QCHB1EZ-223	0.022MF 25V CER. CAP.	
	C665	QFV81HJ-104	0.1MF 50V THIN FILM CAP.	
	C671	QCXB1CM-222Y	2200PF 16V CER. CAP.	
	C672	QCXB1CM-222Y	2200PF 16V CER. CAP.	
	C674	QCHB1EZ-223	0.022MF 25V CER. CAP.	
	C675	QCHB1EZ-223	0.022MF 25V CER. CAP.	
	C679	QEK51AM-107	100MF 10V AL E. CAP.	
	C693	QEK61AM-227ZM	220MF 10V AL E. CAP.	
	C694	QCHB1EZ-223	0.022MF 25V CER. CAP.	
		RESISTORS		
	R601	QRD161J-123	12K 1/6W CARBON RES.	
	R603	QRD161J-125	1.2M 1/6W CARBON RES.	
	R605	QRD161J-274	270K 1/6W CARBON RES.	
	R606	QRD167J-154	150K 1/6W CARBON RES.	
	R607	QRD161J-273	27K 1/6W CARBON RES.	
	R609	QRD161J-114	110K 1/6W CARBON RES.	
	R610	QRD161J-104	100K 1/6W CARBON RES.	
	R611	QRD161J-473	47K 1/6W CARBON RES.	
	R612	QRD167J-822	8.2K 1/6W CARBON RES.	
	R613	QRD167J-121	120 1/6W CARBON RES.	
	R614	QRD161J-100	10 1/6W CARBON RES.	
	R615	QRD161J-120	12 1/6W CARBON RES.	
	R616	QRD161J-910Y	91 1/6W CARBON RES.	
	R632	QRD167J-151	150 1/6W CARBON RES.	
	R641	QRD161J-683	68K 1/6W CARBON RES.	

△	Item	Parts Number	Description	Area
	R642	QRD161J-222	2.2K 1/6W CARBON RES.	
	R643	QRD167J-822	8.2K 1/6W CARBON RES.	
	R644	QRD167J-223	22K 1/6W CARBON RES.	
	R645	QRD167J-223	22K 1/6W CARBON RES.	
	R646	QRD161J-222	2.2K 1/6W CARBON RES.	
	R647	QRD161J-472	4.7K 1/6W CARBON RES.	
	R650	QRD161J-182	1.8K 1/6W CARBON RES.	
	R651	QRD161J-102	1K 1/6W CARBON RES.	
	R652	QRD161J-102	1K 1/6W CARBON RES.	
	R653	QRD161J-102	1K 1/6W CARBON RES.	
	R660	QRD161J-102	1K 1/6W CARBON RES.	
	R661	QRD161J-683	68K 1/6W CARBON RES.	
	R662	QRD167J-275	2.7M 1/6W CARBON RES.	
	R663	QRD161J-124	120K 1/6W CARBON RES.	
	R664	QRD161J-471	470 1/6W CARBON RES.	
	R666	QRD161J-220	22 1/6W CARBON RES.	
	R667	QRD161J-220	22 1/6W CARBON RES.	
	R671	QRD161J-102	1K 1/6W CARBON RES.	
	R672	QRD161J-102	1K 1/6W CARBON RES.	
	R692	QRD161J-271	270 1/6W CARBON RES.	
		OTHERS		
		EMW10688-002A	PRINTED BOARD	
	X651	ECX0169-344EF	CRYSTAL	
	CN601	EMV7171-115R	CONNECT TERMINAL	
	CN602	EMV5109-006A	CONNECT TERMINAL	
	CN603	VMC0163-R07	CONNECT TERMINAL	
	CN604	VMC0163-R11	CONNECT TERMINAL	
	SP601	VYH7237-001SS	I. C. COVER	
	SP602	VYH7237-003	I. C. COVER	
	SP603	VYH7237-003	I. C. COVER	
	TP601	OMV5004-002K	PLUG ASSY	
	TW601	EFW102-047	TERMINAL WIRE	

## ■ Electrical Parts List (ENA-178)

△	Item	Parts Number	Description	Area
		I. C. S		
	IC102	LA1837	I. C (MONO-ANALOG)	
	IC121	LC72131	I. C (M)	
		DIODES		
	D121	1SS133	SI. DIODE	
	D123	1SS133	SI. DIODE	
	D129	1SS133	SI. DIODE	
	D130	MTZ10JC	ZENER DIODE	
		TRANSISTORS		
	Q101	2SC461	SI. TRANSISTOR	
	Q102	2SC535	SI. TRANSISTOR	
	Q103	2SC461	SI. TRANSISTOR	
	Q121	DTA124ES	DIGITAL TRANSISTOR	
	Q123	2SC2060 (Q. R)	SI. TRANSISTOR	
		CAPACITORS		
	C101	QCVB1CM-103Y	0.01MF 16V CER. CAP.	
	C102	QETN1EM-107Z	100MF 25V E. CAP.	
	C103	QCHB1EZ-223	0.022MF 25V CER. CAP.	
	C104	QCHB1EZ-223	0.022MF 25V CER. CAP.	
	C105	QCHB1EZ-223	0.022MF 25V CER. CAP.	
	C107	QETN1EM-226Z	22MF 25V E. CAP.	
	C109	QETN1EM-226Z	22MF 25V E. CAP.	
	C111	QCHB1EZ-223	0.022MF 25V CER. CAP.	
	C112	QCT30CH-120Y	12PF 50V CER. CAP.	
	C117	QCSB1HK-5R6Y	5.6PF 50V CER. CAP.	
	C118	QCSB1HJ-150Y	15PF 50V CER. CAP.	
	C121	QCT30CH-180Y	18PF 50V CER. CAP.	
	C122	QCT30CH-180Y	18PF 50V CER. CAP.	
	C123	QCC21EM-473	0.047MF 25V CER. CAP.	
	C126	QCB1HK-101Y	100PF 50V CER. CAP.	
	C128	QENB1HM-474	0.47MF 50V NP E. CAP.	
	C129	QGB1HK-102	1000PF 50V CER. CAP.	
	C130	QETN1EM-107Z	100MF 25V E. CAP.	
	C133	QETN1EM-226Z	22MF 25V E. CAP.	
	C135	QCHB1EZ-223	0.022MF 25V CER. CAP.	
	C136	QETN1HM-105Z	1MF 50V AL E. CAP.	
	C137	QCB1HK-681Y	680PF 50V CER. CAP.	
	C139	QFLB1HJ-333	0.033MF 50V MYLAR CAP.	
	C140	QFLB1HJ-333	0.033MF 50V MYLAR CAP.	
	C141	QCC21EM-473	0.047MF 25V CER. CAP.	
	C143	QCHB1EZ-223	0.022MF 25V CER. CAP.	
	C144	QCC21EM-473	0.047MF 25V CER. CAP.	
	C146	QETN1HM-105Z	1MF 50V AL E. CAP.	
	C147	QETN1HM-105Z	1MF 50V AL E. CAP.	
	C148	QETN1HM-474Z	0.47MF 50V AL E. CAP.	
	C149	QETN1HM-105Z	1MF 50V AL E. CAP.	
	C150	QETN1EM-226Z	22MF 25V E. CAP.	
	C156	QCHB1EZ-223	0.022MF 25V CER. CAP.	
	C157	QCC21EM-473	0.047MF 25V CER. CAP.	
	C158	QETN1EM-226Z	22MF 25V E. CAP.	
	C161	QETN1HM-105Z	1MF 50V AL E. CAP.	
	C162	QETN1HM-105Z	1MF 50V AL E. CAP.	
	C163	QCHB1EZ-223	0.022MF 25V CER. CAP.	
	C164	QCC21EM-473	0.047MF 25V CER. CAP.	
	C168	QFV81HJ-274	0.27MF 50V THIN FILM CAP.	
	C180	QETN1EM-107Z	100MF 25V E. CAP.	
	C181	QFLB1HJ-562	5600PF 50V MYLAR CAP.	
	C182	QFLB1HJ-562	5600PF 50V MYLAR CAP.	
	C183	QCHB1EZ-223	0.022MF 25V CER. CAP.	
	C184	QETN1EM-107Z	100MF 25V E. CAP.	
	C185	QETN1HM-105Z	1MF 50V AL E. CAP.	
	C186	QETN1HM-105Z	1MF 50V AL E. CAP.	
		RESISTORS		
	R102	QRD167J-332	3.3K 1/6W CARBON RES.	
	R103	QRD161J-221	220 1/6W CARBON RES.	
	R104	QRD167J-272	2.7K 1/6W CARBON RES.	
	R105	QRD161J-391	390 1/6W CARBON RES.	
	R106	QRD161J-102	1K 1/6W CARBON RES.	
	R107	QRD161J-561	560 1/6W CARBON RES.	
	R108	QRD167J-332	3.3K 1/6W CARBON RES.	

△	Item	Parts Number	Description	Area
	R109	QRD161J-221	220 1/6W CARBON RES.	
	R115	QRD161J-104	100K 1/6W CARBON RES.	
	R119	QRD161J-103	10K 1/6W CARBON RES.	
	R121	QRD161J-473	47K 1/6W CARBON RES.	
	R122	QRD161J-472	4.7K 1/6W CARBON RES.	
	R124	QRD161J-222	2.2K 1/6W CARBON RES.	
	R126	QRD167J-562	5.6K 1/6W CARBON RES.	
	R127	QRD167J-822	8.2K 1/6W CARBON RES.	
	R128	QRD161J-472	4.7K 1/6W CARBON RES.	
	R129	QRD161J-222	2.2K 1/6W CARBON RES.	
△	R130	QRD14CJ-680SX	68 1/4W UNF. CARBON R	
	R132	QRD161J-102	1K 1/6W CARBON RES.	
	R133	QRD167J-822	8.2K 1/6W CARBON RES.	
	R134	QRD161J-102	1K 1/6W CARBON RES.	
	R140	QRD161J-183	18K 1/6W CARBON RES.	
	R141	QRD161J-472	4.7K 1/6W CARBON RES.	
	R142	QRD161J-470	47 1/6W CARBON RES.	
	R143	QRD167J-562	5.6K 1/6W CARBON RES.	
	R144	QRD167J-332	3.3K 1/6W CARBON RES.	
	R145	QRD161J-103	10K 1/6W CARBON RES.	
	R146	QRD167J-332	3.3K 1/6W CARBON RES.	
	R147	QRD167J-153	15K 1/6W CARBON RES.	
	R148	QRD161J-561	560 1/6W CARBON RES.	
	R150	QRD161J-101	100 1/6W CARBON RES.	
	R157	QRD167J-682	6.8K 1/6W CARBON RES.	
	R158	QRD167J-682	6.8K 1/6W CARBON RES.	
	R161	QRD161J-102	1K 1/6W CARBON RES.	
	R162	QRD161J-102	1K 1/6W CARBON RES.	
	R163	QRD161J-472	4.7K 1/6W CARBON RES.	
	R164	QRD161J-472	4.7K 1/6W CARBON RES.	
	R181	QRD161J-102	1K 1/6W CARBON RES.	
	R182	QRD161J-103	10K 1/6W CARBON RES.	
	R183	QRD161J-103	10K 1/6W CARBON RES.	
	R184	QRD161J-103	10K 1/6W CARBON RES.	
		OTHERS		
		EMW10684-002A	PRINTED BOARD	
	L111	EQL4007-150T	INDUCTOR	
	T111	EQR7121-007	RF COIL	
	T141	QGR0613-001	I. F. TRANSFORMER	
	T142	QAX0303-001	CERAMIC FILTER	
	X121	ECX0007-200KWJ1	CRYSTAL	
	AT101	FMMB10YV-401K	ANTENNA TERMINAL	
	CF101	QAX0285-001Z	CERAMIC FILTER	
	CF102	QAX0285-001Z	CERAMIC FILTER	
	CN111	EMV5163-012R	CONNECT TERMINAL	
	FL141	EQF0101-013	LOWPASS FILTER	
	FL142	EQF0101-013	LOWPASS FILTER	
	RF101	EAF2207-001	FRONT END	

## ■ Electrical Parts List (END-107)

△	Item	Parts Number	Description	Area
		DIODES		
	D2001	1SS133	SI. DIODE	
	D2002	1SS133	SI. DIODE	
	D2003	1SS133	SI. DIODE	
	D2004	1SS133	SI. DIODE	
	D2005	1SS133	SI. DIODE	
		TRANSISTORS		
	Q2001	DTC114YS	DIGITAL TRANSISTOR	
	Q2001	KRC107M-T	DIGITAL TRANSISTOR	
	Q2002	DTC114YS	DIGITAL TRANSISTOR	
	Q2003	DTC114YS	DIGITAL TRANSISTOR	
		CAPACITORS		
	C2001	QETN1EM-226Z	22MF 25V E. CAP.	
	C2002	QETN1EM-106Z	10MF 25V E. CAP.	
		RESISTORS		
	R2001	QRD161J-103	10K 1/6W CARBON RES.	
	R2002	QRD167J-223	22K 1/6W CARBON RES.	
	R2003	QRD161J-103	10K 1/6W CARBON RES.	
	R2004	QRD167J-223	22K 1/6W CARBON RES.	
		OTHERS		
		EMW10723-001	CIR. BORAD	
	CN291	EMV7145-003Z	SOCKET ASSY	
	CN292	EMV7145-003Z	SOCKET ASSY	
		I. C. S		
	IC802	TA8409S	I. C (MONO-ANALOG)	
	IC803	TA8409S	I. C (MONO-ANALOG)	
		CAPACITORS		
	C803	QFLB1HJ-102	1000PF 50V MYLAR CAP.	
	C804	QCFB1HZ-104Y	0.1MF 50V CER. CAP.	
	C805	QCVB1CM-103Y	0.01MF 16V CER. CAP.	
	C808	QFLB1HJ-102	1000PF 50V MYLAR CAP.	
	C810	QCZ0205-155	1.5MF 25V C. CAP.	
	C811	QCZ0205-155	1.5MF 25V C. CAP.	
	C813	QCVB1CM-103Y	0.01MF 16V CER. CAP.	
	C821	QCBB1HK-102Y	1000PF 50V CER. CAP.	

## ■ Electrical Parts List (Changer Control P.C. Board)

△	Item	Parts Number	Description	Area
		I. C. S		
	IC802	TA8409S	I. C (MONO-ANALOG)	
	IC803	TA8409S	I. C (MONO-ANALOG)	
		CAPACITORS		
	C803	QFLB1HJ-102	1000PF 50V MYLAR CAP.	
	C804	QCFB1HZ-104Y	0.1MF 50V CER. CAP.	
	C805	QCVB1CM-103Y	0.01MF 16V CER. CAP.	
	C808	QFLB1HJ-102	1000PF 50V MYLAR CAP.	
	C810	QCZ0205-155	1.5MF 25V C. CAP.	
	C811	QCZ0205-155	1.5MF 25V C. CAP.	
	C813	QCVB1CM-103Y	0.01MF 16V CER. CAP.	
	C821	QCBB1HK-102Y	1000PF 50V CER. CAP.	
		RESISTORS		
	R805	QRD161J-102	1K 1/6W CARBON RES.	
	R806	QRD161J-471	470 1/6W CARBON RES.	
	R807	QRD161J-471	470 1/6W CARBON RES.	
	R808	QRD161J-102	1K 1/6W CARBON RES.	
	R810	QRD161J-684	680K 1/6W CARBON RES.	
	R811	QRD161J-105	1M 1/6W CARBON RES.	
	R813	QRD161J-102	1K 1/6W CARBON RES.	
	R814	QRD161J-102	1K 1/6W CARBON RES.	
	R815	QRD161J-102	1K 1/6W CARBON RES.	
	R816	QRD161J-102	1K 1/6W CARBON RES.	
	R817	QRD161J-102	1K 1/6W CARBON RES.	
	R818	QRD161J-102	1K 1/6W CARBON RES.	
	R819	QRD161J-102	1K 1/6W CARBON RES.	
	R820	QRD161J-102	1K 1/6W CARBON RES.	
	R821	QRD161J-102	1K 1/6W CARBON RES.	
	R822	QRD161J-102	1K 1/6W CARBON RES.	
	R823	QRD161J-102	1K 1/6W CARBON RES.	
	R824	QRD161J-102	1K 1/6W CARBON RES.	
	R825	QRD161J-102	1K 1/6W CARBON RES.	
	R826	QRD161J-102	1K 1/6W CARBON RES.	
	R827	QRD161J-102	1K 1/6W CARBON RES.	
	R828	QRD161J-102	1K 1/6W CARBON RES.	
	R829	QRD161J-102	1K 1/6W CARBON RES.	
	R830	QRD161J-102	1K 1/6W CARBON RES.	
	R832	QRD161J-181	180 1/6W CARBON RES.	
	R833	QRD161J-102	1K 1/6W CARBON RES.	
	R834	QRD161J-102	1K 1/6W CARBON RES.	
	R839	QRD167J-332	3.3K 1/6W CARBON RES.	
	R840	QRD167J-562	5.6K 1/6W CARBON RES.	
		OTHERS		
		QEK51AM-107	AL. E. CAP.	
		QEK51CM-476	AL. E. CAP.	
		QEK51EM-475	AL. E. CAP.	
		SBSF2608Z	TAPPING SCREW	
		UPD65612GB-208	I. C (M)	
		VMW1377-004X	PW BOARD	
		VYH7237-001SS	IC HOLDER	
	L801	VQP0018-100	INDUCTOR	
	L802	VQP0033-100Z	INDUCTOR	
	L803	VQP0033-100Z	INDUCTOR	
	L804	VQP0033-100Z	INDUCTOR	
	CN801	VMC0163-R10	CONNECT TERMINAL	
	CN802	VMC0289-P07	CONNECT TERMINAL	
	CN803	VMC0324-12310	CONNECT TERMINAL	
	CN804	VMC0289-S07K	CONNECTOR	

## Accessories List

Block No. **M5MM**

△	Item	Parts Number	Parts Name	Q'ty	Description	Area
	1	E30580-2538A	INSTRUCTION BOOK	1		J
		E30580-2539A	INSTRUCTION BOOK	1		C
	2	E309758-003	POLY BAG	1		
	3	EQB4001-015	LOOP ANTENNA	1		
	4	BT-20071B	SERVICE NETWORK	1		C
	5	BT-51006-1	REGISTER CARD	1		J
	6	BT-52002-1	WARRANTY CARD	1		C
	7	EWP201-011	ANTENNA WIRE	1		
	8	BT-20044G	SAFETY SHEET	1		J
	9	RM-SED60TU	WIRE-LESS REMOTE CONTROL	1		
	10	R6PRPA-2STSA	DRY CELL	1		

Packing Materials and Part Numbers

Block No. **M6MM**

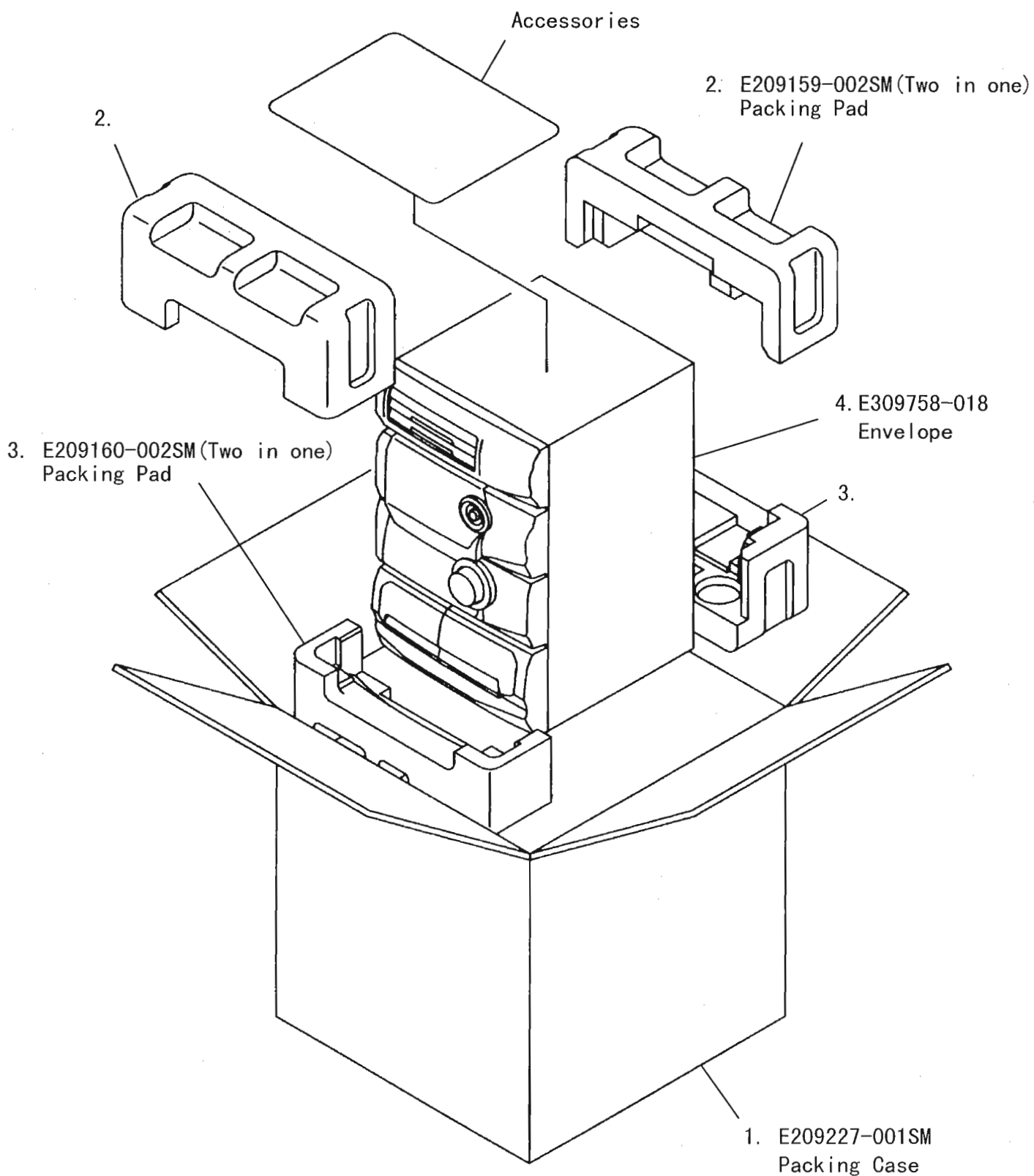



**JVC**

VICTOR COMPANY OF JAPAN, LIMITED  
AUDIO PRODUCT DIVISION 1644, SHIMOTURUMA, YAMATO-SHI, KANAGAWA-KEN, 242, JAPAN

