

JVC

SERVICE MANUAL

COMPACT COMPONENT SYSTEM

FX-F3000/FX-F3000R : AX-F3000

FM/AM TUNER

INTEGRATED AMPLIFIER

XL-F3000

COMPACT DISC PLAYER

:TD-F3000

DOUBLE CASSETTE DECK

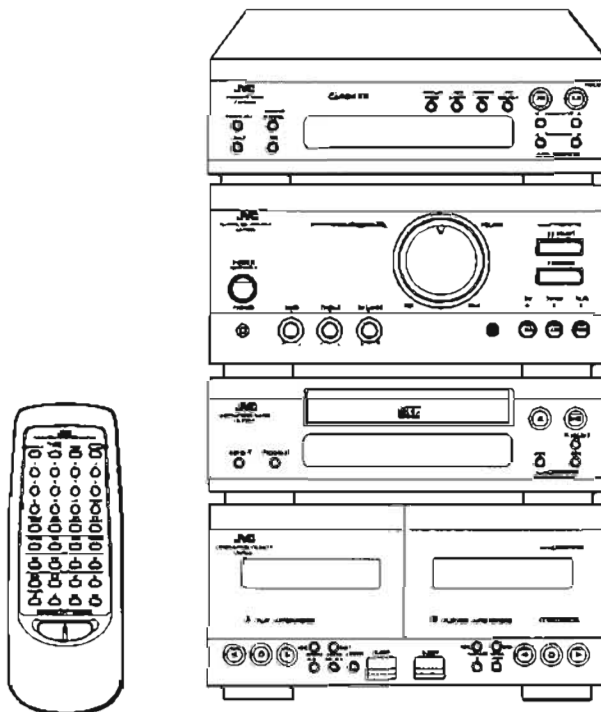

Pick up	OPTIMA-6
CD signal processor	MN66270RB

Area Suffix

BS	the U.K.
C	Canada
EF	Continental Europe Except Germany & Italy
EN	Nordic Countries
G	Germany
J	the U.S.A
UB	Hong Kong
US	Singapore
UT	Taiwan
U	Universal Except All of Above

COMPACT
disc
DIGITAL AUDIO

Note: Press S510 on ENH-296-1 for checking only AX-F3000 unit or units except FX-F3000/FX-F3000R.
Discharge C404 after services.

Contents

<i>Safety Precautions</i>	1-2	<i>Parts List</i>	
<i>Important for Laser Products</i>	1-3	<i>AX-F3000</i>	6-1
<i>Instruction Book</i>	1-4	<i>XL-F3000</i>	7-1
<i>AX-F3000</i>	2-1	<i>TD-F3000</i>	8-1
<i>XL-F3000</i>	3-1	<i>FX-F3000/FX-F3000R</i>	9-1
<i>TD-F3000</i>	4-1	<i>Accessories List</i>	10-1
<i>FX-F3000/FX-F3000R</i>	5-1	<i>Packing Materials</i>	10-2

Safety Precautions

1. The design of this product contains special hardware and many circuits and components specially for safety purposes. For continued protection, no changes should be made to the original design unless authorised in writing by the manufacturer. Replacement parts must be identical to those used in the original circuits.
2. Any unauthorised design alterations or additions will void the manufacturer's guarantee ; furthermore the manufacturer cannot accept responsibility for personal injury or property damage resulting therefrom.
3. Essential safety critical components are identified by (Δ) on the Parts List and by shading on the schematics ,and must never be replaced by parts other than those listed in the manual. Please note however that many electrical and mechanical parts in the product have special safety related characteristics . These characteristics are often not evident from visual inspection . Parts other than specified by the manufacturer may not have the same safety characteristics as the recommended replacement parts shown in the Parts List of the service manual and may create shock , fire , or other hazards .
4. The leads in the products are routed and dressed with ties, clamps, tubings, barriers and the like to be separated from live parts, high temperature parts, moving parts and/or sharp edges for the prevention of electric shock and fire hazard. When service is required, the original lead routing and dress should be observed, and it should be confirmed that they have been returned to normal, after re-assembling.

Warning

1. Service should be performed by qualified personnel only.
2. This equipment has been designed and manufactured to meet international safety standards.
3. It is the legal responsibility of the repairer to ensure that these safety standards are maintained.
4. Repairs must be made in accordance with the relevant safety standards.
5. It is essential that safety critical components are replaced by approved parts.
6. If mains voltage selector is provided, check setting for local voltage .

Important for Laser Products

1. **CLASS 1 LASER PRODUCT**
2. **DANGER** : Invisible laser radiation when open and interlock failed or defeated. Avoid direct exposure to beam.
3. **CAUTION** : There are no serviceable parts inside the Laser Unit. Do not disassemble the Laser Unit. Replace the complete Laser Unit if it malfunctions.
4. **CAUTION** : The compact disc player uses invisible laser radiation and is equipped with safety switches which prevent emission of radiation when the drawer is open and the safety interlocks have failed or are defeated. It is dangerous to defeat the safety switches.
5. **CAUTION** : If safety switches malfunction, the laser is able to function.
6. **CAUTION** : Use of controls, adjustments or performance of procedures other than those specified herein may result in hazardous radiation exposure.
7. **CAUTION** : The compact disc player provides a laser diode of wavelength 780-790nm and optical output power typical 3mW at the laser diode.

VARNING : Osynlig laserstrålning när denna del är öppnad och spärren är urkopplad. Betrakta ej strålen.

VARO : Avattaessa ja suojalukitus ohitettaessa olet alttiina näkymättömälle lasersäteilylle. Älä katso säteeseen.

ADVARSEL : Usynlig laserstrålning ved åbning, når sikkerhedsafbrydere er ude af funktion. Undgå udsættelse for stråling.

ADVARSEL : Usynlig laserstrålning ved åbning, når sikkerhedsbryteren er avslott. unngå utsettelse for stråling.

REPRODUCTION AND POSITION OF LABELS

WARNING LABEL

(Except for the U. S. A.)

DANGER: Invisible laser radiation when open and interlock failed or defeated. AVOID DIRECT EXPOSURE TO BEAM. (e)

VARNING: Osynlig laserstrålning när denna del är öppnad och spärren är urkopplad. Betrakta ej strålen. (s)

ADVARSEL: Usynlig laserstrålning ved åbning, når sikkerhedsafbrydere er ude af funktion. Undgå udsættelse for stråling. (d)

VARO: Avattaessa ja suojalukitus ohitettaessa olet alttiina näkymättömälle lasersäteilylle. Älä katso säteeseen. (f)

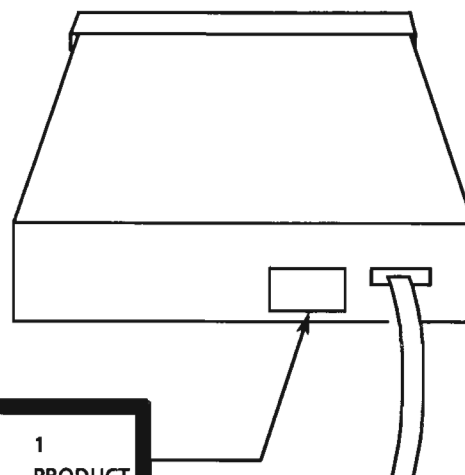
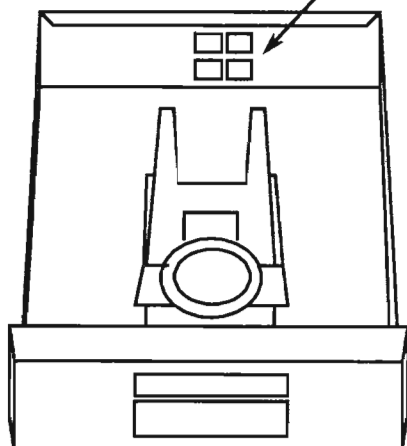

**CLASS 1
LASER PRODUCT**

CLASSIFICATION LABEL

(Except for the U. S. A. and Canada)

Table of Contents

Introduction	2
How This Manual Is Organized	2
Getting Started	3
Accessories	3
Putting Batteries in the Remote Control	3
Connecting the External Wire	3
Connecting the System Control Cords	4
Connecting the Speakers	4
Connecting the FM Antenna	5
Connecting the AM (MW/LW) Antenna	5
Connecting the Minidisc Recorder and Other Equipment	6
Switches, Buttons and Controls	7
Front Panel	7
Remote Control	9
Displays	10
Tuner Display	10
CD Player Display	10
Using the Amplifier	11
Turning the System On and Off	11
Turning the System On	11
Turning the System Off	11
Controlling the Sound	11
Volume Control	11
Speaker Balance Control	11
Bass Control	11
Treble Control	11
Using the CD DIRECT Function	12
Using the PRESENCE Function	12
Listening with Headphones	12
Using the Tuner	13
One Touch Radio	13
Tuning in Stations Manually	13
Receiving in Stereo or Monaural	13
Presetting Stations in Memory	13
Tuning in Preset Stations	14
Erasing the Preset Stations	14
Receiving FM Stations with RDS (Radio Data System)	15
What Information RDS Can Provide	15
Searching for Programs by PTY Codes	16
Setting EON Standby Reception	16
ALARM Function	17
Using the CD Player	18
Basics of Using the CD Player	18
Playing a CD	18
Finding the Track or a Particular Point You Want	18
Locating a Track with the Remote Control Directly	19
Programming the Playing Order of the Tracks	19
Repeating a Selection or the Entire Disc	20
Using the Cassette Deck (Listening to a Tape)	21
One Touch Play	21
Regular Play	21
Fast Left and Fast Right	22
Music Scan	22
Finding the Beginning of the Next Song	22
Finding the Beginning of the Current Song	22
Other Useful Features of the Cassette Deck	23
Reverse Mode	23
Continuous Play (only available when Reverse mode is on)	23
Dolby Noise Reduction	23
Dolby HX PRO	23
Listening to the Turntable or Other Equipment through Your System	24
Using JVC's Minidisc Recorder Connected to the COMPU LINK-3 • MD Terminal	24
Using the Cassette Deck (Recording)	25
Things to Know before You Start Recording	25
Standard Recording	26
Recording any Sound Source to Tape	26
CD to Tape Recording	27
Tape to Tape Recording (Dubbing)	28
Using the Timer	29
Setting the Clock	29
Setting the Recording (REC) Timer	29
Setting the Daily Timer	30
Setting the Sleep Timer	32
Timer Priority	33
Care and Maintenance—General Notes	34
Compact Discs	34
Moisture Condensation	34
Cassette Tapes	34
Cassette Deck	34
Troubleshooting	35
Specifications	36

Introduction

Here are some of the things that make your components (hereafter, called "System") easy to use.

- The controls and operations have been redesigned to make them easy to use so you can spend your time listening to music.
- With the One Touch Play feature of JVC's COMPU PLAY, you can turn on the System and start the tuner, the cassette deck, or the CD player with a single touch. If the System is not ready, such as no CD or tape in place, the System still turns on and then pauses so you can put in a CD or tape.
- Three timers, Recording, Daily, and Sleep Timers, are extremely easy to set so you can really use them.
- A home-use RDS tuner offers most of the RDS services. These services include the display of station names and program types, and scanning stations by using the program types.



How This Manual Is Organized

- This manual explains how to use the following four components.
 - FM/MW/LW Tuner FX-F3000R
 - Integrated Amplifier AX-F3000
 - Compact Disc Player XL-F3000
 - Double Cassette Deck TD-F3000
- This manual mainly explains operations using the buttons and controls on the front panels. If operation using the Remote Control is different from that using the buttons on the front panels, it is then explained.

IMPORTANT CAUTIONS

- 1 Installation of the System**
 - Select a place which is level, dry, and neither too hot nor too cold (between 5°C and 35°C or 41°F and 95°F).
 - Leave sufficient distance between the System and your TV.
 - Keep the speakers away from TV to avoid interference with TV.
 - Do not use the System in a place subject to vibrations.
- 2 Power cord**
 - Do not handle the power cord with wet hands!
 - The small amount of the power (11 watts) is always consumed as long as the power cord is connected to the wall outlet.
 - When unplugging from the wall outlet, always pull the plug, not the power cord.
- 3 Malfunctions, etc.**
 - There are no user serviceable parts inside. If anything goes wrong, unplug the power cord and consult your dealer.
 - Do not insert any metallic object into the cabinets.

Getting Started

Accessories

Check to be sure you have all of the following things, which are supplied with the System:

- FM Wire Antenna (1)
- AM (M/W/L/W) Loop Antenna (1)
- Remote Control (1)
- Batteries (2)
- External Wire (1)

If any are missing, contact your dealer immediately.

Putting Batteries in the Remote Control

Match the polarity (+ and -) on the batteries with the + and - markings on the battery compartment.

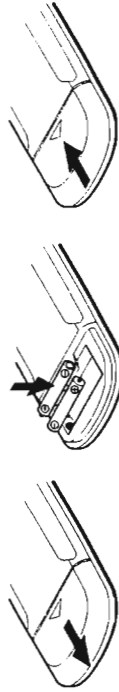

R03 (UM-4VAAA) (24F)

If the range or effectiveness of the Remote Control decreases, replace the batteries. Use two R03 (UM-4VAAA) (24F) type dry-cell batteries.

CAUTION

- To avoid battery leakage or explosion:
- Remove batteries when the Remote Control is not used for a long time.
 - When you need to replace the batteries, replace both batteries at the same time with new ones.
 - Do not use an old battery together with a new one.
 - Do not use different types of batteries together.
 - Do not expose batteries to heat or flame.

Connecting the External Wire

To prevent malfunction, connect the supplied wire as illustrated below.

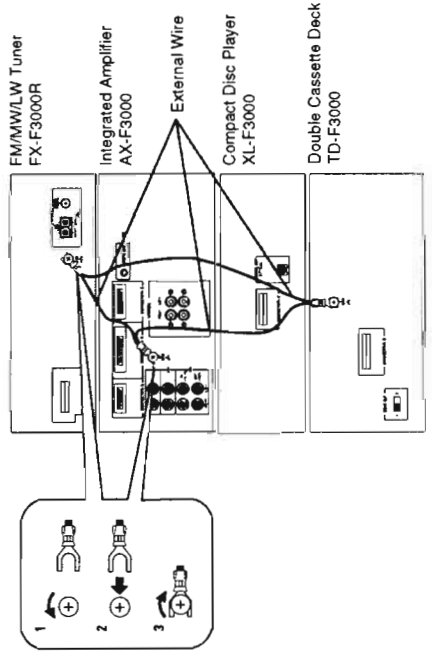

CAUTION

First make all connections before plugging the System into the AC power outlet.

Connecting the System Control Cords

Connect the components with the system control cords as illustrated below.

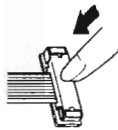
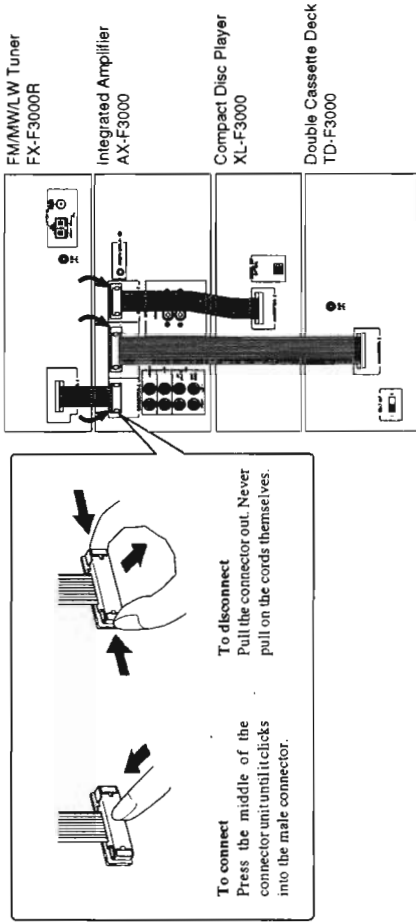

To connect
Press the middle of the connector until it clicks into the male connector.

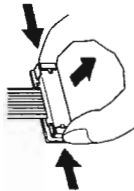

To disconnect
Pull the connector out. Never pull on the cords themselves.

Note

When connecting the components with the system control cords, make sure to connect the terminals having the same names like "CONNECTOR-A" or "CONNECTOR-B".

Connecting the Speakers



Twist and remove the insulation at the end of each speaker signal cable first, and then, connect the speakers to the SPEAKERS terminals by using the cables.

For each speaker, connect the black (-) and red (+) terminals on the rear panel to the black (-) and red (+) terminals marked on the speakers.

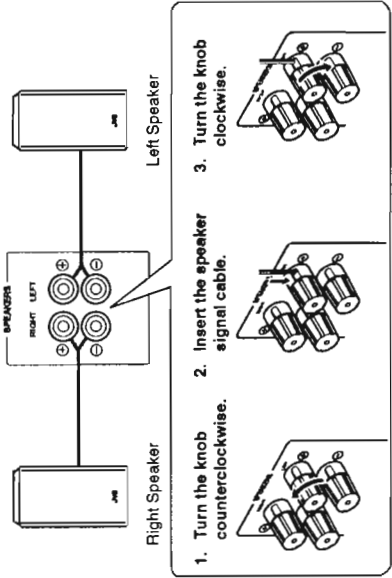

1. Turn the knob counterclockwise.
2. Insert the speaker signal cable.
3. Turn the knob clockwise.

CAUTIONS

- Use speakers with the same speaker impedance indicated by the speaker terminals.
- If the TV is installed near speakers, irregular colors may result. In this case, set the TV away from the speakers.

Connecting the FM Antenna

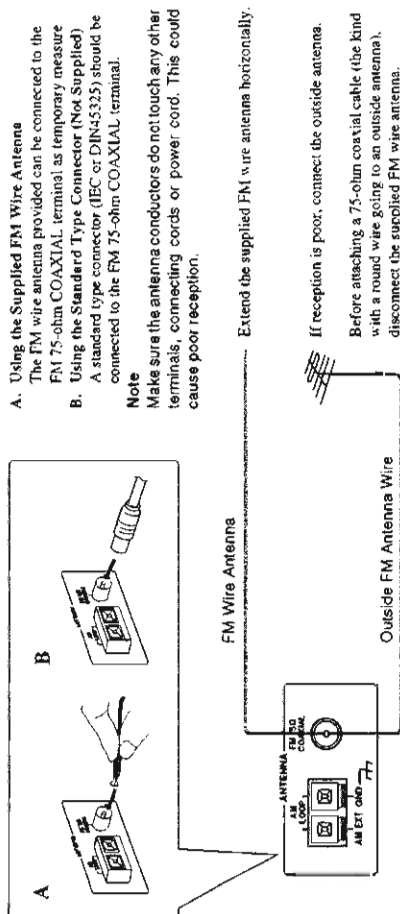

- A. Using the Supplied FM Wire Antenna
The FM wire antenna provided can be connected to the FM 75-ohm COAXIAL terminal as temporary measure
 - B. Using the Standard Type Connector (Not Supplied)
A standard type connector (IEC or DIN45325) should be connected to the FM 75-ohm COAXIAL terminal.
- Note**
Make sure the antenna conductors do not touch any other terminals, connecting cords or power cord. This could cause poor reception.

Extend the supplied FM wire antenna horizontally.

If reception is poor, connect the outside antenna. Before attaching a 75-ohm coaxial cable (the kind with a round wire going to an outside antenna), disconnect the supplied FM wire antenna.

CAUTION
To avoid noise, keep antennas away from metallic parts of the System, connecting cords and the AC power cord.

Connecting the AM (MW/LW) Antenna

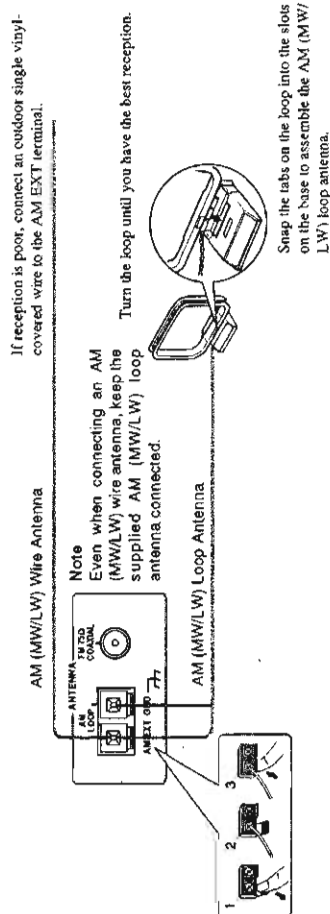

- Note**
Even when connecting an AM (MW/LW) wire antenna, keep the supplied AM (MW/LW) Loop antenna connected.
- If reception is poor, connect an outdoor single vinyl-covered wire to the AM EXT terminal.
- Turn the loop until you have the best reception.

Snap the tabs on the loop into the slots on the base to assemble the AM (MW/LW) loop antenna.

CAUTION

First make all connections before plugging the System into the AC power outlet.

Connecting the Minidisc Recorder and Other Equipment

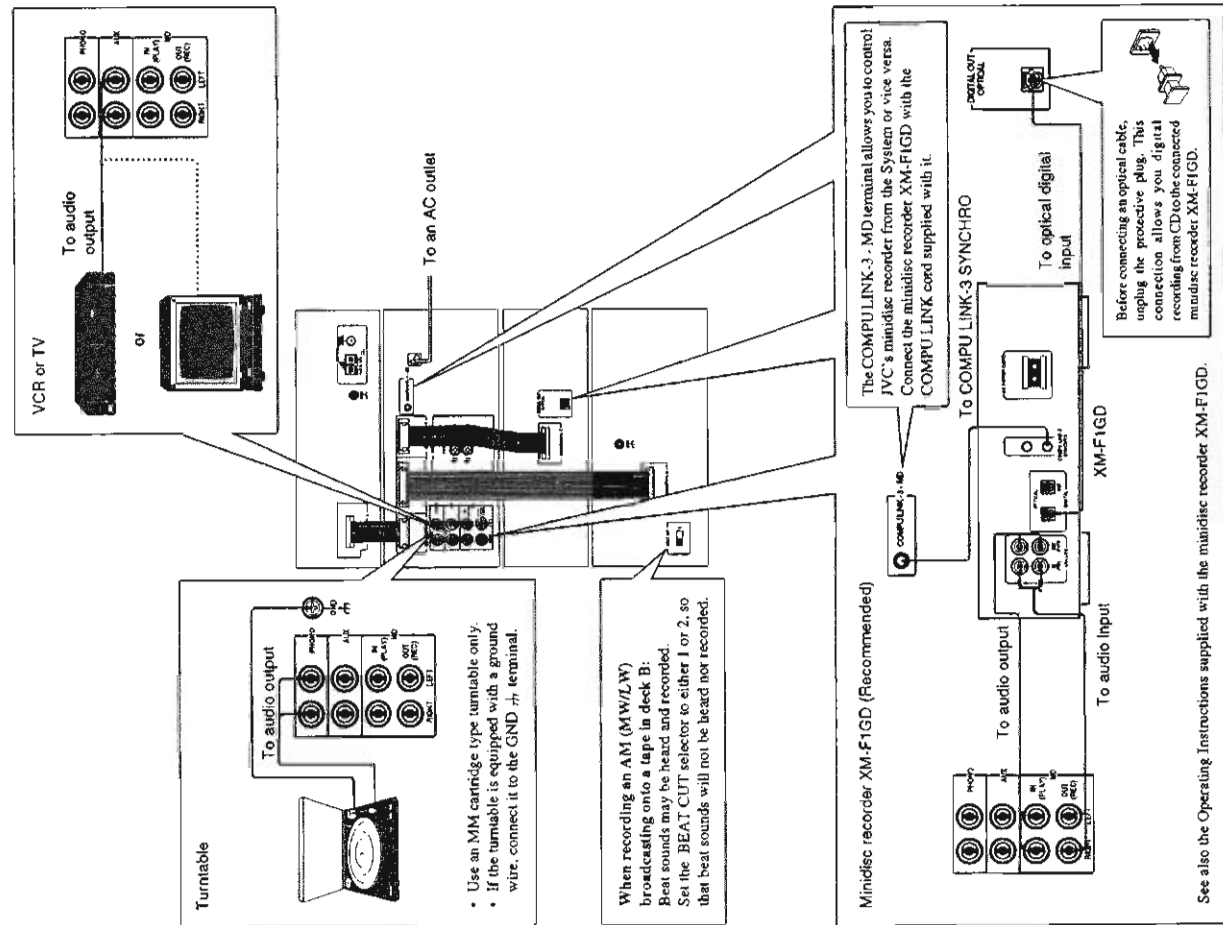

Turntable

- Use an MM cartridge type turntable only.
- If the turntable is equipped with a ground wire, connect it to the GND terminal.

When recording an AM (MW/LW) broadcasting onto a tape in deck B:
• Beat sounds may be heard and recorded. Set the BEAT CUT selector to either 1 or 2, so that beat sounds will not be heard nor recorded.

Minidisc recorder XM-F1GD (Recommended)

The COMPU LINK-3 MD terminal allows you to control JVC's minidisc recorder from the System or vice versa. Connect the minidisc recorder XM-F1GD with the COMPU LINK cord supplied with it.

Minidisc recorder XM-F1GD

To audio output

To optical digital input

To audio input

To COMPU LINK-3 SYNCHRO

Before connecting an optical cable, unplug the protective plug. This connection allows you digital recording from CD to the connected minidisc recorder XM-F1GD.

See also the Operating Instructions supplied with the minidisc recorder XM-F1GD.

Switches, Buttons and Controls

Become familiar with the buttons and controls on the front panels before use.

Front Panel

FM/MW/LW Tuner FX-F3000R

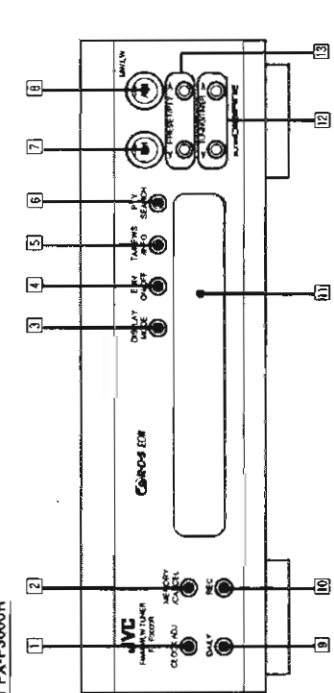

Integrated Amplifier AX-F3000

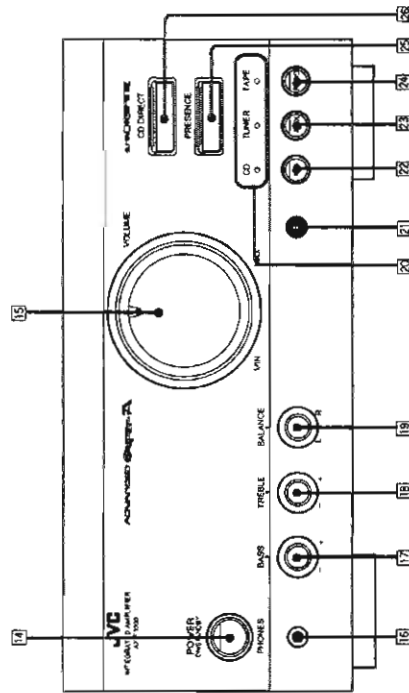

Refer to the pages in parentheses for details.

FM/MW/LW Tuner FX-F3000R

- 1 CLOCK ADJ. button (29)
- 2 MEMORY/CANCEL button (13, 14)
- 3 DISPLAY MODE button (15)
- 4 EON ON/OFF button (16)
- 5 T/NEWS/INFO button (16)
- 6 PTY SEARCH button (16)
- 7 FM button and indicator (13)
- 8 AM (MW/LW) button and indicator (13)
- 9 DAILY button (30)
- 10 REC button (28)
- 11 Display (10)
- 12 TUNING/TIMER </> buttons (13, 29)
- 13 PRESET/PTY </> buttons (14, 16)

Integrated Amplifier AX-F3000

- 14 POWER button and ON/STANDBY indicator (11)
- 15 VOLUME control and indicator (11)
- 16 PHONES jack (12)
- 17 BASS control (11)
- 18 TREBLE control (11)
- 19 BALANCE control (11)
- 20 Source indicators (CD/TUNER/TAPE)
- 21 Remote sensor
- 22 MD button and indicator (24)
- 23 AUX button and indicator (24)
- 24 PHONO button and indicator (24)
- 25 PRESENCE button and indicator (12)
- 26 CD DIRECT button and indicator (12)

Compact Disc Player XL-F3000

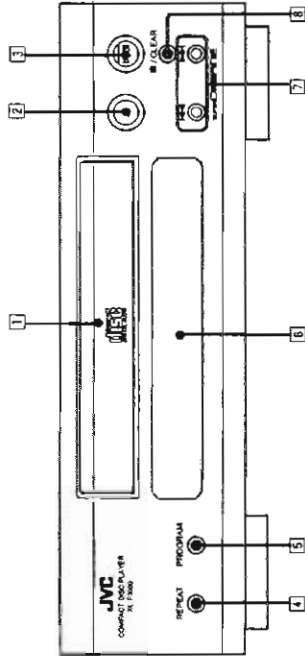

Double Cassettes Deck TD-F3000

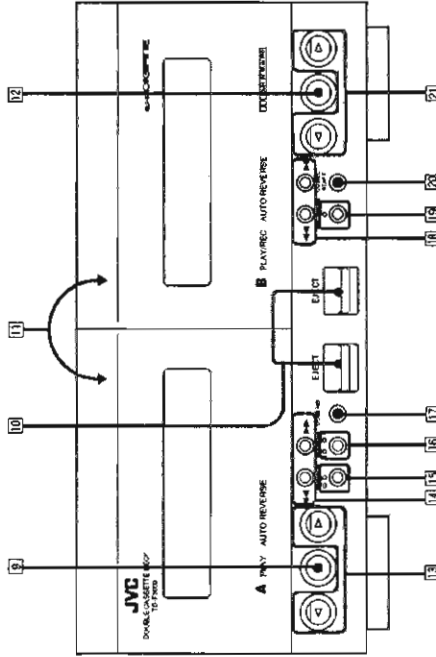

Refer to the pages in parentheses for details.

Compact Disc Player XL-F3000

- 1 CD tray (18)
- 2 (Open/Close) button (18)
- 3 (Play/Pause) button and indicator (18)
- 4 REPEAT button (20)
- 5 PROGRAM button (20)
- 6 Display (10)
- 7 (Skip Left/Skip Right or Fast Forward/Fast Reverse) buttons (18)
- 8 (Stop)/CLEAR button (18, 20)

Double Cassettes Deck TD-F3000

- 9 (Stop) button (for Deck A) (21)
- 10 EJECT buttons (21)
- 11 Cassette Holders
- 12 (Stop) button (for Deck B) (21)
- 13 </> (Play Forward/Play Reverse) buttons and indicators (for Deck A) (21)
- 14 (Fast Left/Fast Right) buttons (for Deck A) (22)
- 15 REVERSE button and indicator (23)
- 16 DOLBY NR button and indicators (21)
- 17 DUBBING button (28)
- 18 (Fast Left/Fast Right) buttons (for Deck B) (22)
- 19 REC PAUSE button and indicator (26)
- 20 CD REC START button (27)
- 21 </> (Play Forward/Play Reverse) buttons and indicators (for Deck B) (21)

Remote Control

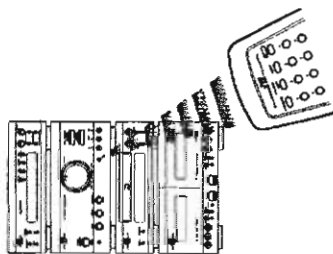

When using the Remote Control, aim it to the remote sensor on the front panel.

Refer to the pages in parentheses for details.

- 1 FM MODE MUTE button (13)
- 2 PROGRAM button (19)
- 3 10-key pad (14, 19)
- 4 EON ON/OFF button (16)
- 5 DISPLAY MODE button (15)
- 6 CD player control section (18)
 - ▶ (Play) button (18)
 - (Stop) button (18)
 - ◀/▶ (Skip Left/Skip Right) buttons (18)
- 7 VOLUME button (+/-) (11)
- 8 SLEEP button (32)
- 9 POWER button (11)
- 10 CANCEL button (20)
- 11 PTY SEARCH button (16)
- 12 PTY SELECT button (16)
- 13 Source selecting buttons (TUNER/MD/AUX/PHONO) (13, 24)
- 14 Cassette deck control section (21)
 - ▶ (Play) button (for Deck A) (21)
 - (Stop) button (for Deck B) (21)
 - ◀/▶ (Play) buttons (21)
 - (Stop) button (21)
 - ◀/▶ (Fast Left/Fast Right) buttons (22)
 - REC PAUSE ● button (for Deck B only) (26)

Note

When you use the Remote Control, be sure which source the Remote Control is activated for.

- Before controlling the tuner and using the 10-key pad to select preset stations, press TUNER first on the Remote Control.
- Before controlling the CD player and using the 10-key pad to select CD tracks, press ▶, then ■ on the CD control section first.
- Before controlling the cassette deck, press ● or ■ on the cassette deck control section first to select which deck to use.

Displays

Tuner Display

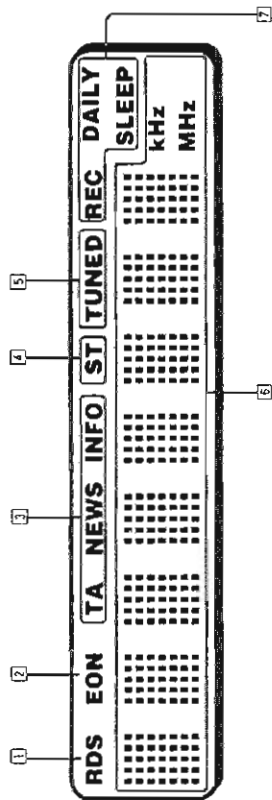

CD Player Display

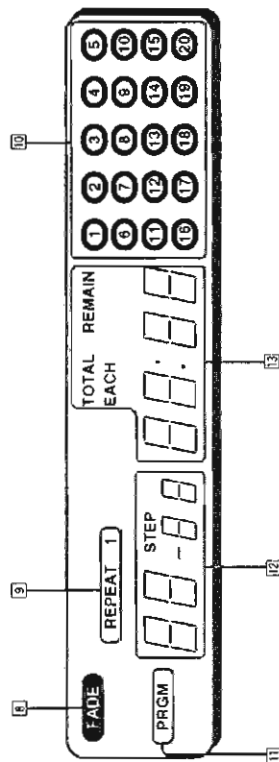

Refer to the pages in parentheses for details.

- Tuner Display**
 - 1 RDS indicator (15)
 - 2 EON indicator (16)
 - 3 EON Standby reception indicator (T/NEWS/INFO) (16)
 - 4 ST (Stereo) indicator (13)
 - 5 TUNED indicator (13)
 - 6 Clock frequency, timer-on time, timer-off time display (13, 29)
 - 7 Timer indicators (29, 30, 32)
- CD Player Display**
 - 8 FADE indicator (27)
 - 9 REPEAT indicator (20)
 - 10 Track number display
 - 11 PRGM (Program) indicator (19)
 - 12 Track and program step display
 - 13 Playing time, remaining time display

Using the Amplifier

Here are some basic things to use this System. If something in a later procedure is unclear to you, check back here.

Turning the System On and Off

POWER ON/STANDBY



Turning the System On

Press POWER so that the ON/STANDBY indicator goes off.

- The System comes on ready to do whatever it was doing when the power was last shut off.

Turning the System Off

Press POWER again so that the ON/STANDBY indicator lights up and the display blanks, except for the clock indication.

- The small amount of the power (11 watts) is always consumed even in standby mode.
- To turn off the System completely, unplug the AC power cord from the AC outlet. When you unplug the AC power cord, the preset stations of the tuner will be erased in a few days.

Controlling the Sound

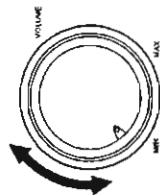

The same set of buttons and knobs control the sound, no matter which sound source is producing it.

Volume Control

Rotate the VOLUME control clockwise to increase the volume, counterclockwise to reduce it.

On the Remote Control:

Press VOLUME + to increase the volume, VOLUME - to reduce it.



Speaker Balance Control

If the sounds you hear from the right and left speakers are not well-balanced, you can adjust the speaker output balance with the BALANCE control.

Bass Control

Rotate the BASS control clockwise to increase bass reinforcement, counterclockwise to reduce bass reinforcement.

Treble Control

Rotate the TREBLE control clockwise to increase treble reinforcement, counterclockwise to reduce treble reinforcement.

Using the CD DIRECT Function

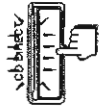

This function is useful when you want to listen to a CD with higher sound quality. The playback signal from the CD player is output directly, without passing through the BASS, TREBLE, BALANCE control circuits, and PRESENCE circuit.

To use this function, press CD DIRECT so that the indicator lights up.

To cancel this function, press CD DIRECT again so that the indicator goes off.

Notes

- If you press CD DIRECT while the power is on, CD play starts with a CD loaded.
- The CD DIRECT function and the PRESENCE function cannot be used at the same time. If you press CD DIRECT while using the PRESENCE function, the PRESENCE function will be canceled.

Using the PRESENCE Function



This function is useful when you listen to music at low volume or with small speaker systems.

To use this function, press PRESENCE so that the indicator lights up.

To cancel this function, press PRESENCE again so that the indicator goes off.

Note

The PRESENCE function and the CD DIRECT function cannot be used at the same time. If you press PRESENCE while using the CD DIRECT function, the CD DIRECT function will be canceled.

Listening with Headphones

A standard pair of headphones can be connected at the PHONES jack on the front panel. No sound can be heard from the speakers.

CAUTION

Be sure to turn down the volume before connecting or putting on headphones, as high volume can damage both the headphones and your hearing.

Using the Tuner

You can listen to both FM and AM (MW/LW) stations. Stations can be tuned manually, automatically, or from preset memory. Before listening to the radio, check that both the FM and AM (MW/LW) antennas are firmly connected. (See page 5.)

One Touch Radio



Just press AM (MW/LW) to turn on the System and start playing the most recent AM (MW/LW) station tuned in, or press FM to start the most recent FM station playing. If you press TUNER on the Remote Control instead, you can start playing the most recent station tuned in.

- You can switch from any other sound source to the tuner by pressing either AM (MW/LW) or FM.

Tuning in Stations Manually

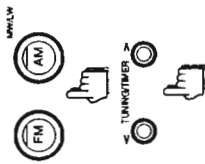

- Press FM or AM (MW/LW) to turn on the System.
- Press and release TUNING/TIMER < or > to move from station to station until you find the one you want.

OR

 Hold down TUNING/TIMER < or >, the frequency starts changing on the display. As soon as a station is tuned in, the TUNED indicator lights up on the display and the frequency stops changing. Repeat this procedure until a station you want is tuned in.

Receiving in Stereo or Monaural



When an FM stereo broadcast is hard to receive or noisy:

- Press FM MODE MUTE on the Remote Control so that "FM MONO" appears on the display and reception improves, although you lose the stereo effect. In this state, you will hear some noise while tuning into a station.
- To restore the stereo effect, press FM MODE MUTE again so that the "FM AUTO" appears on the display. In this state, when a program is broadcast in stereo, the ST (Stereo) indicator lights up on the display and you will hear the stereo sound; when in monaural, the ST indicator goes off and you will hear the monaural sound. Furthermore, in this state you will not hear noise while tuning in stations.

Presetting Stations in Memory

Once stations are assigned to channel numbers, any of these stations can quickly be called up.

- You can preset a total of 40 stations: either FM or AM (MW/LW).
- In order to use RDS broadcasting effectively, you need to preset stations in memory. Both PTY Search and EON function (which will be explained later) are applicable only to the preset FM stations.
- In some cases, test frequencies have been already memorized for the tuner since the factory examined the tuner preset function before shipment. This is not a malfunction. You can preset the stations you want into memory by following the presetting method.

IMPORTANT

When you want to preset FM stations in stereo: Press FM MODE MUTE on the Remote Control so that "FM AUTO" appears on the display before presetting stations.

- Tune in the station you want to preset (see above).
- Press MEMORY/CANCEL. "memo P_ _" appears on the display for about 5 seconds.



- Press PRESET/PTY < or > to assign a channel number while "P_ _" is blinking on the display.
- Press MEMORY/CANCEL. "stored" appears on the display.
 - If you store a new station on a used number, the new station erases the previously stored one.
- Repeat steps 1 to 4 for each station you want to store in memory.

CAUTION
If the System is unplugged or if a power failure occurs, the preset stations will be erased in a few days. If this happens, preset the stations again.

Tuning in Preset Stations

This method is possible after presetting stations by yourself.

- Press FM or AM (MW/LW).
- Press once and release PRESET/PTY > (or <) to go to the next (or previous) preset station, or hold PRESET/PTY < or > to cycle through the preset station: release the button when the preset station you want appears on the display.

The stations you have not preset are skipped.

You can use the Remote Control to tune in preset stations

- Press TUNER so that you can receive the most recent station tuned in.
- Select the station by entering the preset number you want using the 10 key pad.
 - Example: For number 5, press 5. For number 15, press +10 then 5. For number 20, press +10 then 10.
 - If you select the stations you have not preset, "canceled" appears on the display.

Erasing the Preset Stations

You can also use the MEMORY/CANCEL button to cancel the preset stations.

- Hold down MEMORY/CANCEL for about 5 seconds. "canc. P_ _" appears on the display.
- Press PRESET/PTY < or > to assign a channel number while "P_ _" is blinking on the display.
- Press MEMORY/CANCEL. "canceled" appears on the display.
- Repeat steps 1 to 3 for each station you want to erase.



Receiving FM Stations with RDS (Radio Data System)



RDS is a broadcasting service a growing number of FM stations are now providing. It allows the FM stations to send additional signals along with their regular program signals. For example, the stations send their station names and information about what type of program they broadcast, such as sports or music, etc.

When tuned to an FM station providing the RDS service, the RDS indicator lights up on the display, the station frequency (and then the station name if sent) is displayed.

One convenient RDS service is "Enhanced Other Networks (EON)". This allows the tuner to automatically switch to a program of your choice when one starts in your broadcast area.

- Not all FM stations provide RDS service, nor do all RDS stations provide the same services. If in doubt, check with local radio stations for details on RDS services in your area.

Note
RDS may not operate correctly if the station tuned is not transmitting data properly or if the signal strength is weak.

What Information RDS Can Provide

The following RDS services are available and you can see the following RDS information by pressing DISPLAY MODE.

RDS Service Available

PS (Program Service name)
Identifies each station by a name.

Clock Time (Non-RDS service)
Displays the time.

RT (Radio Text)
Allows the RDS station to send text messages that appear on the tuner display.

PTY (Program Type)
Identifies the type of RDS program.

- While RDS information is being received from a station, "wait PS", "wait PTY", or "wait RT" may appear on the display.

The program types are as follows:

- TRAFFIC:** Traffic announcement (usually called "TA")
- NEWS:** News
- INFO:** Programs on medical service, weather forecast, etc.
- POP M:** Pop music
- ROCK M:** Rock music
- M.O.R. M:** Middle-of-the-road music (usually called "easy listening")
- LIGHT M:** Light music
- CLASSICS:** Classics
- OTHER M:** Other music
- AFFAIRS:** Topical program expanding on current news or affairs
- SPORT:** Sports events
- EDUCATE:** Educational programs
- DRAMA:** Radio plays
- CULTURE:** Programs on national or regional culture
- SCIENCE:** Programs on natural sciences and technology
- VARIED:** Other programs like comedies or ceremonies
- NONE:** Undefined

ALARM: Emergency broadcasts

Station Frequency (Non-RDS service)
Displays station frequencies.

Presets Channel Number (Non-RDS service)
Displays preset channel numbers.

Note

If you press DISPLAY MODE while receiving non-RDS FM stations or AM (MW/LW) stations, the display only shows the clock time, station frequency, and preset channel number in sequence.

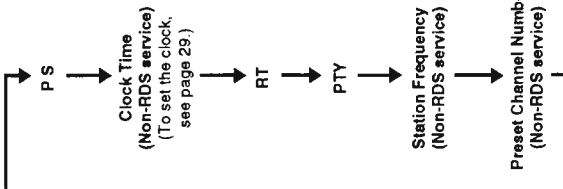

Searching for Programs by PTY Codes

One of the advantages of the RDS service is that you can locate a particular kind of program by specifying the PTY (Program Type) codes.

- PTY Search can be used even while receiving AM (MW/LW) broadcasts or while playing the other source.
- PTY Search is applicable to preset FM stations only.

1. Press PTY SEARCH.

"PTY" and "select" alternates on the display.

2. Press PRESET/PTY < or > (or PTY SELECT on the Remote Control) to select a PTY (Program Type) code.

When you press PRESET/PTY < or > on the front panel, the PTY codes change in the following order (when using the Remote Control, they change only rightward):
TRAFFIC ↔ NEWS ↔ INFO ↔ POP M ↔ ROCK M ↔ M.O.R. M ↔ LIGHT M ↔ CLASSICS ↔ OTHER M ↔ AFFAIRS ↔ SPORT ↔ EDUCATE ↔ DRAMA ↔ CULTURE ↔ SCIENCE ↔ VARIED ↔ NONE ↔ (back to the beginning)

3. Press PTY SEARCH again while the selected PTY code remains on the display.

Searching starts.
 The selected PTY code blinks during PTY Search.

Notes

- Once the station broadcasting the selected PTY code is found, searching stops. Then the station is tuned in and the preset channel number appears on the display. The preset channel number stays blinking for 10 seconds before searching ends.
- If you press PTY SEARCH again during this period, search for the same PTY code will restart. PTY Search is only completed when the indicated preset channel number stops blinking and stays lit.
- If stations broadcasting a program of the selected PTY code is not found, "No PGM" appears on the display after going through the preset channels.

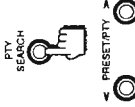

On the front panel

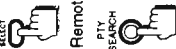

From the Remote Control



Setting EON Standby Reception

With the EON (Enhanced Other Networks) code, the System can perform a standby reception which enables you to obtain desired PTY code(s) available from other stations.

- The EON indicator will light up only while receiving stations with an EON code.
- You can set EON Standby reception with either band (FM or AM (MW/LW)) received.
- EON Standby reception is not applicable in the following cases:
 - While playing the other sources.
 - While receiving non-RDS FM stations and AM (MW/LW) stations. (EON indicator will not light up.)

1. Press EON ON/OFF so that "EON MODE" appears on the display.

Indicator of the PTY code(s) (T/NEWS/INFO) previously selected lights up.

2. Select PTY code(s) you want by pressing T/NEWS/INFO.

TA: Traffic announcement in your area.
NEWS: News
INFO: Programs on medical service, weather forecast, etc.

Each time you press T/NEWS/INFO, the EON Standby reception (T/NEWS/INFO) indicator changes as follows:
 "TA NEWS INFO" → "TA INFO" → "NEWS INFO" → "TA NEWS" → (back to the beginning)

As soon as your selection is entered, the tuner goes into the EON Standby reception mode.

Using the CD Player

Here are the basic things you need to know to play a CD and locate the different sections on it. Each section is called a track, so when we are talking about locating a track, we are also talking about how you find a certain song or performance.

Basics of Using the CD Player

The quickest way to start a CD is with One Touch Play:

- Press **▶/▶** (Play) on the CD player (or **▶** on the CD player control section of the Remote Control)
- If a CD is already loaded, the System automatically turns on and starts playing the CD.
- If no CD is loaded, the CD tray comes out so you can put in a CD, with printed side up. Then press **▶/▶** (or **▶** on the CD player control section). The tray closes and the CD starts playing.
- If you press **◀** (Open), the System automatically turns on and the CD tray comes out.

IMPORTANT

When you use the Remote Control, Remember you have to press **▶**, then **■** on the CD player control section to activate the 10 key pad for the CD player.



Playing a CD



1. Press **▶** (Open).
2. Put a CD, with printed side up, into the tray.
When using an 8 cm CD, place it on the inner circle of the tray.

CAUTION

Place the disc correctly on the circle of the tray.

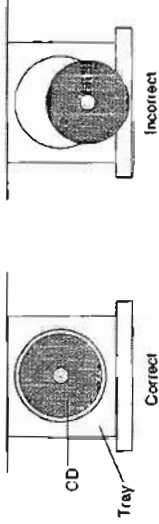

On the front panel



From the Remote Control

3. Press **▶/▶** (or **▶** on the CD player control section of the Remote Control).
 - The CD tray closes automatically.
 - The display shows the track being played and the length of time since it started.

To stop the CD, press **■**/CLEAR (or **■** on the CD player control section of the Remote Control).

To pause the play, press **⏸** (Pause) on the front panel while the CD is playing.

To resume playing, press **▶/▶** (Play) again. (The Pause function cannot be used with **▶** on the CD player control section of the Remote Control.)

To remove a CD, press **◀** (Open), take the CD out, and press **▶** (Close) again to close the tray. Keep the tray closed except during loading and unloading to protect the mechanism from dust and damage.

Finding the Track or a Particular Point You Want

You can easily find the CD track and particular point you want by the following procedure:

- Each time you press briefly and release **⏪** or **⏩** (Stop Left or Skip Right) the track changes by one.
- Press and release **⏪** to go ahead one track at a time.
- Press and release **⏩** to go back one track at a time.
- Hold down **⏪** or **⏩** (when the CD player is stopped) allows you to change tracks continuously.
- Hold down **⏪** or **⏩** (Fast Forward or Past Reverse) on the front panel during play will fast forward or fast reverse the CD so you can quickly find the particular point of a track you want to listen to. (The Fast Forward and Fast Reverse functions cannot be used from the Remote Control.)



While the tuner is for EON Standby reception, the display changes as follows:

1. While waiting for EON data of your selection,



Notes

- If no EON data is received, the tuner remains in this mode.
- If the information you are waiting for is available from the current station, the indicator of the received PTY code will blink.

2. When the information of desired PTY data is received, the tuner tunes into the station sending the PTY data (sound is muted).

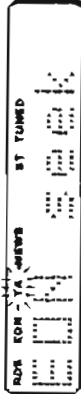

3. When the station is tuned in, the indicator of received PTY code starts blinking.



If the reception is failed, the previous station name and "EON seek" alternates on the display, and then, the indicator of the PTY code goes off and "EON fail" appears. The tuner then goes back to the station previously tuned.

4. When broadcasting of the desired PTY code ends, "EON end" appears and the tuner automatically goes back to the station previously tuned in.

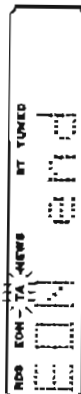

To cancel the EON Standby reception, press EON ON/OFF (or TA/NEWS/INFO) while receiving the station tuned by EON Standby reception.

Notes

- EON broadcasts of some stations may not be compatible with the System. In the case of an incompatible EON broadcast, the EON indicator on the display may not light up.
- While receiving a program of the selected PTY code(s) by EON Standby reception, the station will not change to other stations even if a program of the same type is available from them.
- When a timer (recording or daily) starts operating while the EON Standby reception is operating, the EON Standby reception will be canceled, and the source selected by the timer will be played.
- While a timer (recording or daily) is operating, the EON Standby reception will not function.

ALARM Function

When an ALARM (Emergency) broadcast is being received, the tuner tunes in the station broadcasting the ALARM signal "ALARM" and the station frequency will alternate on the display for your attention.

- ALARM function cannot work in the following cases:
 - While playing the other sources.
 - While receiving non-RDS FM stations and AM (MWLW) stations.

Programming the CD from the front panel by the following procedure:

1. **Press PROGRAM.**
The PRGM indicator lights up on the display.
2. **Press ◀ or ▶ (Skip Left or Skip Right) to select the track you want.**
3. **Press PROGRAM to store the selected track.**
4. **Repeat steps 2 and 3 until you enter all the tracks you want to play.**
You can repeat the same tracks if you want.
5. **Press ▶ (Play) to start playing the tracks in the order you have programmed.**



To stop the CD during programmed play, press ■/CLEAR.

To erase the program, press ■/CLEAR after you stop playing.

Before you start playing, you can do the following:

- If you want to change the entire program, press ■/CLEAR on the front panel (or PROGRAM on the Remote Control). You can also erase the entire program by pressing ◀ (Open).
- If you want to erase the last track, press CANCEL on the Remote Control. Each time you press CANCEL the last track in the program will be erased.
- To add a track to your program, just press the number you want to add using the Remote Control. (This is also possible during play.)

Repeating a Selection or the Entire Disc

You can have either all tracks or the individual track currently playing repeat as many times as you like by pressing REPEAT.

- Each time you press REPEAT, it cycles in the following order:

- REPEAT → REPEAT 1 → Off (The REPEAT indicator goes off.) → (go back to the beginning)
- REPEAT Repeat all tracks in order or according to the program you have made.
- REPEAT 1 Repeat the currently playing track.
- Off Repeat is canceled.



Locating a Track with the Remote Control Directly

Using the 10 key pad on the Remote Control allows you to go directly to the beginning of any track.

1. **Press ▶, then ■ on the CD player control section.**
This activates the 10 key pad for controlling the CD player.
2. **Enter the number of the track you want using the 10 key pad.**
Example: For track 5, press 5. For track 15, press +10 then 5. For track 20, press +10 then 10.
3. **As long as a CD is loaded and the System is on, the CD starts playing from the selected track.**

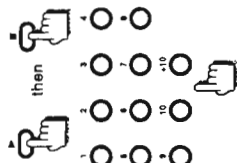

Programming the Playing Order of the Tracks

You can arrange the tracks to play in any order you like. The Remote Control is very useful for this because you can select tracks by number with the 10 key pad. You can also use the buttons on the front panel.

- You can program up to 32 tracks in any desired order.
- You can only make or change a program when the CD player is stopped.

Programming the CD track order from the Remote Control by the following procedure:

1. **Press ▶ then ■ on the CD player control section.**
This activates the 10 key pad for controlling the CD player.
2. **Press PROGRAM.**
The PRGM indicator lights up on the display.
3. **Press the number of the first track, then the number of the second track, and so on until you enter all the track numbers you want to play.**
• Example: For track 5, press 5. For track 15, press +10 then 5. For track 20, press +10 then 10.
• You can repeat the same tracks if you want.
4. **Press ▶ on the CD player control section to start playing the tracks in the order you have programmed.**

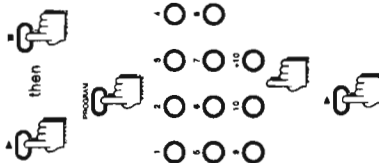

To stop the CD during programmed play, press ■.

To erase the program, press PROGRAM after you stop playing.

Using the Cassette Deck (Listening to a Tape)

You can play, record and dub audio tapes by using the cassette deck.

- To record or dub, see Recording on page 25.
- With Automatic Tape Type Detection, you can listen to Type I, II and IV tapes without changing any settings.
- Most tapes are now recorded with the Dolby NR system (B or C), so first check which type of the Dolby NR system is used on the tape.

IMPORTANT

When you use the Remote Control, Remember you have to press **◀** or **▶** on the cassette deck control section to select which deck to use.

One Touch Play



Regular Play

By pressing either ▷ or ◁ on either deck A or B, the System automatically turns on, and if a tape is in the deck, it starts playing. If no tape is loaded, the System turns on and wait for further instructions.

When power is already on, you can use these basic procedures:

1. Press EJECT for the deck you want to use.
2. When the cassette holder opens, put the cassette tape in, with the exposed part of the tape down toward the base of the holder.
If the cassette holder does not open, turn the System off once and turn it on again, then press EJECT.
3. Close the cassette holder gently.
4. Press DOLBY NR repeatedly to set the same Dolby NR system as was used for recording the tape.
5. Press ◁ (or ▶ on the cassette deck control section of the Remote Control) to play the reverse side, or ▷ (or ▶ on the cassette deck control section) to play the front side.
 - Tape starts playing.
 - The indicator on the pressed button (◁ or ▷) starts blinking slowly, showing which way the tape is running.

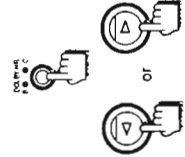
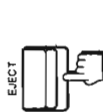

On the front panel

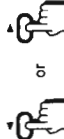

From the Remote Control

To stop playing, press □ (or ■ on the cassette deck control section of the Remote Control). The indicator on the button (◁ or ▷) stops blinking, showing which way the tape was running last.

To remove the tape, press EJECT.

Fast Left and Fast Right

- While the tape is stopped, press ◀◀ and the tape will wind rapidly onto the left side of the cassette tape without playing.
- While the tape is stopped, press ▶▶ and the tape will wind rapidly onto the right side of the cassette tape without playing.

CAUTION
The use of C-120 (120 minutes turn around) or thinner tape is not recommended, since characteristic deterioration may occur and these tapes easily jam in the pinch and the capstan.

Music Scan

Shows the direction the tape runs

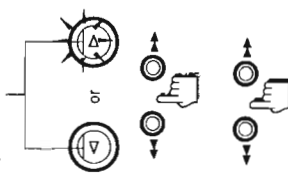

You can use Music Scan to locate the beginning of a song. Music Scan searches for blank portions that usually separate recorded songs, then plays the next song.

Finding the Beginning of the Next Song

During play, press ◀◀ or ▶▶ in the same direction as the tape play. Searching stops automatically at the beginning of the next song, and the next song starts automatically.

Finding the Beginning of the Current Song

During play, press ◀◀ or ▶▶ in the opposite direction to the tape play. Searching stops automatically at the beginning of the current song, and the current song starts automatically.

Notes

- Music Scan works by detecting a 4-second long blank between each song, so it will not work well in the following cases.
 - No blank at the beginning of a song
 - Noise (often caused by much use or poor quality dubbing) which fills the blank with noise.
 - Long, very soft passages or pauses in a song.
- Music Scan only works on one tape at a time.
 - If you use Music Scan on deck A during recording on deck B, deck B enters recording pause mode (except during "CD to Tape Recording").
 - If you start recording on deck B while Music Scan is used on deck A, Music Scan stops.

Other Useful Features of the Cassette Deck



Reverse Mode

Use Reverse Mode to make the tape automatically reverse at the end of a side and start playing the other side. Press REVERSE to change Reverse Mode from on (when the indicator is lit) to off and vice versa.

Continuous Play (only available when Reverse Mode is on)

Use Continuous Play to play the tapes in both deck A and B.

When Reverse Mode is set to on (the indicator is lit):

When the reverse side (←) of a tape finishes playing on one deck, the System always checks to see if a tape is in the other deck. If there is, it automatically starts playing. This happens regardless of which deck starts first.



Dolby Noise Reduction

Press DOLBY NR to switch Dolby Noise Reduction (B or C) on (the selected one's indicator lights up) or off (both indicators go off). If a tape is recorded with the Dolby NR system, playing it back with the same Dolby NR on. It will reduce tape noise and improve the clarity of the sound.

Dolby HX PRO

Dolby HX PRO provides linearity in high-range frequency response during recording. Tapes recorded with this System retain the same characteristic even played back with any other deck. With Dolby HX PRO, the effective bias current is controlled in response to fluctuations in high-range frequency of the input signal, ensuring dynamic sound recording with minimal distortion and noise.

Dolby noise reduction and HX Pro headroom extension manufactured under license from Dolby Laboratories Licensing Corporation. HX Pro originated by Bang & Olufsen. "DOLBY", the double-D symbol and "HX PRO" are trademarks of Dolby Laboratories Licensing Corporation.

Listening to the Turntable or Other Equipment through Your System

By playing the sound from a minidisc recorder, a turntable or other connected equipment through the System, you can often dramatically improve the quality, and gain control over how the music or program sounds.

1. Connect the other equipment as shown on page 6.
2. Turn down the volume using the VOLUME control on the front panel (or VOLUME – on the Remote Control).
3. Press MD, AUX or PHONO .
The System is turned on and MD, AUX or PHONO indicator lights up.
4. Switch on the connected equipment and start playing.
See the manuals supplied with the other equipment.

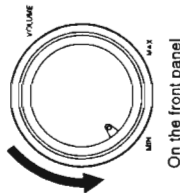

On the front panel



From the Remote Control



To cancel the MD, AUX or PHONO setting, change the source by starting any one of sound sources, such as the tuner or CD player.

Using JVC's Minidisc Recorder Connected to the COMPU LINK-3 - MD Terminal

When your minidisc recorder is JVC's XM-FIGD, you can connect it to the COMPU LINK-3 - MD terminal. You can control the minidisc recorder from the System or vice versa. About the connection, see page 6.

What you can do:

Automatic power on/off function:

When you turn on or off the System, the minidisc recorder automatically turns on or off.

Playing the minidisc recorder:

When you press MD on the System or ▷/◻ (Play) on the minidisc recorder in standby mode, the System and minidisc recorder turn on and start playing if a minidisc is already loaded.

Recording from the minidisc recorder, see page 26.

Recording onto the minidisc:

1. Prepare the CD or cassette tape you want to record from.
2. Prepare the minidisc in the minidisc recorder.
3. Press REC PAUSE on the minidisc recorder.
4. Press ▷/◻ (for the CD) or ◁/▷ (for the cassette tape) on the front panel. As soon as the System starts playing, the minidisc recorder starts recording.



Recording onto cassette tape from any of the sound sources is easy and the System does most of the work. Just have a tape in deck B, have the source ready, make one or two settings, and you are ready to record.

For each source the procedure is a little different and now we explain just what to do for each one. If you forget, just come back to the each section. But first, here are a few things to make your recordings better.

Things to Know before You Start Recording

- It may be unlawful to record or playback copyrighted material without the consent of the copyright owner.
- To reduce hiss noise, press DOLBY NR to select either B or C. (See page 23.)
- The recording level, which is the volume at which the new tape is being made, is automatically set correctly, so it is not affected by the VOLUME control on the front panel (or VOLUME - or + on the Remote Control). Thus, you can adjust the sound you are actually listening without changing the recording. If you do not want to listen to the sound, you can turn down the volume using the VOLUME control on the front panel (or VOLUME - on the Remote Control).
- The BASS/TREBLE controls, and the CD DIRECT/PRESENCE function cannot be used for recording.
- Cassette tapes have a special feature so you will not accidentally record over a tape you want to save. Two small tabs on the back, one for side A and one for side B, can be removed to prevent erasure or re-recording. To record on a cassette with the tabs removed, you must cover the holes with tape first. However, when a Type II tape is used, only cover part of the hole as shown below, since the other part of the hole is used to detect the tape type.



- Type I, II and IV tapes can be used for recording.

CAUTION
If recordings you make have excessive noise or static, the System may be too close to a TV during the recording. Either turn off the TV or increase the distance between the TV and the System.

Standard Recording

This is the basic method for recording any source. The System also has special ways for recording CD to tape, and tape to tape, which save you time and effort, as well as give you some special effects. However, when you need to add a selection to a tape you have made, or are combining selections from several sources on one tape, use the method we describe here. You can record from a minidisc recorder, a turntable or other sources with this procedure.

Recording any Sound Source to Tape

Follow the procedure to record from any sound source onto a tape in deck B.

IMPORTANT

When you use the Remote Control, Remember you have to press **▶** or **▶** on the cassette deck control section to select which deck to use. Press **▶** first before starting the following procedure.

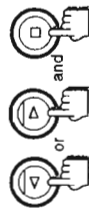

On the front panel

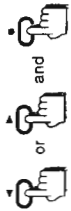

From the Remote Control

1. Put the cassette tape to record onto into deck B.
2. Press **◀** (or **▶** on the cassette deck control section of the Remote Control) or **▶** (or **▶** on the cassette deck control section) and **▶** (or **▶** on the cassette deck control section) to select the side for recording on deck B.
 - When you want to record on the front side (A), press **▶** (or **▶** on the cassette deck control section), then **▶** (or **▶** on the cassette deck control section).
 - When you want to record on the reverse side (B), press **◀** (or **▶** on the cassette deck control section), then **▶** (or **▶** on the cassette deck control section).
3. Press REC PAUSE.
 - The REC PAUSE indicator lights up.
 - When you want to record on both sides of the tape, press REVERSE on the cassette deck to set Reverse Mode on and be sure to start recording from the front side (A). If you start recording from the reverse side (B), the deck stops after recording the reverse side (B) without going to the front side (A), even if Reverse Mode is on.
4. Prepare the source, for example, tuning in a radio station, turning on the connected equipment and then, start playing the source.
 - When you want to record from the CD player or minidisc recorder, you need to do the next step first.
 - When you want to record from IVC's minidisc recorder XM-FIGD connected with COMPU LINK cord, you do not need to do the next step since recording starts automatically.
5. To start recording, press either **◀** (or **▶** on the cassette deck control section of the Remote Control) or **▶** (or **▶** on the cassette deck control section) (the same button you have pressed in step 2).
 - To stop recording any time during the process, press **□** on deck B (or **■** on the cassette deck control section).
 - To pause recording any time during the process, press REC PAUSE again. To resume recording, press **◀** / **▶** (or **▶** / **▶** on the cassette deck control section of the Remote Control) (the same button you have pressed in step 2).

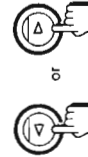

On the front panel

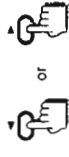

From the Remote Control

CD to Tape Recording

Everything on the CD goes onto the tape in the order it is on the CD or according to an order you have set in a program. To make a program, see page 19. During "CD to Tape Recording", you cannot change the sound sources.

IMPORTANT
When you use the Remote Control, Remember you have to press **◀** or **▶** on the cassette deck control section to select which deck to use. Press **▶** first before starting the following procedure.

- Put the cassette tape in deck B.**
Press REVERSE so that the REVERSE indicator lights up if you want to record on both sides of the tape.
- Load the CD into the CD Player.**
If the CD is already loaded, be sure the System is on.

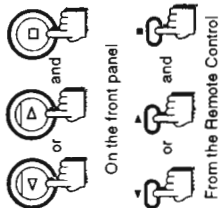

- Press ◀ (or ▶ on the cassette deck control section of the Remote Control) or ▷ (or ▶ on the cassette deck control section) and □ (or ■ on the cassette deck control section) to select the side for recording.**
 - When you want to record on the front side (A), press ▷ (or ▶ on the cassette deck control section), then □ (or ■ on the cassette deck control section).
 - When you want to record on the reverse side (B), press ◀ (or ▶ on the cassette deck control section), then □ (or ■ on the cassette deck control section).

- Press CD REC START on the cassette deck.**
 - The FADE indicator lights up on the CD display.
 - As soon as deck B starts recording, the CD starts playing. At the end of the tape, the System automatically goes back to the beginning of the last track and records it, this time gently fading out at the end. If you set Reverse Mode on, the reverse side (B) starts with the last track on the front side (A) and will be faded out at the end again. (A 10 second blank is created on the beginning of the reverse side (B).)
 - For "CD to Tape Recording" using more than one disc, use a blank tape. If you use a prerecorded tape, prerecorded material may not be erased between newly-recorded tracks.

To stop recording any time during the process, press either ■CLEAR on the CD player (or ■ on the CD player control section of the Remote Control) or □ on deck B. When you press ■CLEAR (or ■ on the cassette deck control section), you can make a 4-second blank at the end of recording.

CAUTION
◀ (Skip Left) or ▶ (Skip Right), and REPEAT will work during "CD to Tape Recording". If you press these buttons, recording will be interrupted.

Tape to Tape Recording (Dubbing)

Recording from one tape to another is called dubbing.

- Dolby NR is inactive in dubbing mode regardless of the setting of the DOLBY NR. The dubbed tape automatically contains the same processing as the source tape. The DOLBY NR indicator goes off automatically.
- It is preferable that the tape type (Type I, II and IV) you record from be the same as the tape type you record onto.
- To dub both sides of a tape, start from the front side (A) for both deck A and B, and press REVERSE so that the REVERSE indicator lights up.

- Put the cassette tape you want to copy from into deck A for playback.**

- Put the cassette tape you want to copy onto into deck B for recording.**

The cassette tape in deck B will be erased as the new sound from the cassette tape in deck A is recorded.



- Press DUBBING.**

- Deck A starts playing and deck B starts recording.
- When dubbing, you can also listen to the another source such as the radio or the CD player.

To stop dubbing, press □ for deck B.

Recording selections from several different tapes

When you want to take selections from several different tapes and combine them on one tape during dubbing, follow these steps:

- Press □ on deck A.**
This causes deck A to stop, so you can change tapes, and deck B makes pauses.
- Change the cassette tape in deck A.**
- Press DUBBING to start deck A playing and deck B recording again.**



On deck A

Using the Timer

The timers let you control recording and playing sources automatically. Three types of timers are available:

- Recording (REC) Timer**—Unattended recording of radio broadcasts that works only once.
- Daily Timer**—The System turns on and plays a source at a particular time every day.
- Sleep Timer**—Fall asleep and have your System turn off automatically after a certain length of time.

Setting the Clock

The timers depend on the clock. If the clock is right, the timers will work like you expect, but if the time is incorrect on the clock then the timers will also be incorrect.

Special Notice: The clock must be set, or the timers cannot be set! So, let's set the clock first.

You can set the clock whether the System is on or off.

1. Press CLOCK ADJ.



2. Set the hours by pressing TUNING/TIMER < or >.

Pressing > increases the hour, and pressing < decreases it.



3. Press MEMORY/CANCEL.



4. Set the minutes by pressing TUNING/TIMER < or >.

Pressing > increases the minute, and pressing < decreases it.



5. Press MEMORY/CANCEL again.

The clock is set and starts from zero second.



CAUTION
If the System is unplugged or if a power failure occurs, the clock loses its setting. The tuner display shows "0:00" and it must be reset.

Setting the Recording (REC) Timer

With the recording timer you can make a tape of a radio broadcast automatically even when you are not there to start the System. For the timer to work correctly, you need to make sure that the tape you want to record onto must be in deck B when you want to record.

- You can set the recording timer whether the System is on or off.
- When you want to record on both sides of the cassette tape, press REVERSE, with the power turned on, so that the REVERSE indicator lights up.

1. Press REC.

The REC indicator blinks on the tuner display.



2. Set the time you want to start recording.

Use TUNING/TIMER < or > and MEMORY/CANCEL just like setting the clock. See instructions above.



3. Set the time you want to stop recording.

Use TUNING/TIMER < or > and MEMORY/CANCEL just like setting the clock. See instructions above.



4. Select a preset channel with PRESET/PTY < or > and MEMORY/CANCEL.

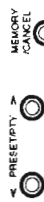

5. Select the equipment (either deck B or minidisc recorder XM-F1GD) you want to use for recording with TUNING/TIMER < or > and MEMORY/CANCEL.

Each time you press TUNING/TIMER < or >, the System gives you one of the following:

TAPE? Records onto a tape
MD? Records onto a minidisc

For connecting and operating the minidisc recorder, see page 6 of this manual and the manuals supplied with the minidisc recorder.

When you select TAPE as the equipment, you need to check that tape direction is correct. This is important especially when Reverse Mode is off.

Set Reverse Mode on and start recording from the front side (A) if you want to record on both sides of the tape.

6. Press REC again.

The REC indicator stops blinking and remains lit. The display, then, shows the settings you have done in step 2 to 5.

- Notice that the REC indicator lights up on the display whenever the timer is set.
- A few seconds before the on-time for the recording, the System automatically turns on if it is off and the REC indicator blinks on the display. When the on-time comes, recording starts. When the off-time comes, recording stops and the System automatically turns off.
- Once the recording timer has worked, the REC indicator goes off. (The recording timer also turns off. However, the contents stored in the timer will not be erased.)

7. Adjust the volume with the VOLUME control (or VOLUME - or + on the Remote Control).

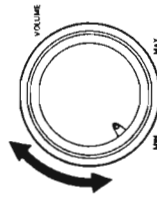

To cancel the recording timer, press REC so that the REC indicator on the display goes off.

To change the timer settings, repeat the setting procedure from the beginning and change the contents as you want.

On the front panel



From the Remote Control

Note

If you change the source while the recording timer is operating, the recording timer will be canceled but the recording continues.

CAUTION

If the System is unplugged or if a power failure occurs, the timer setting will be erased. If settings are erased, reset the timer settings.

Setting the Daily Timer

With the timer you can play the sound source at the specified time without recording them. The daily timer executes the timer operation at the specified time every day.

- You can set the daily timer whether the System is on or off.

1. Press DAILY.

The DAILY indicator blinks on the tuner display.



2. Set the time you want the sound source to turn on.

Use TUNING/TIMER < or > and MEMORY/CANCEL just like setting the clock.

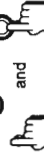

Setting the Sleep Timer

Using this timer, you can fall asleep to music and know your System will turn off by itself rather than play all night.

- You can only set the sleep timer when the System is on.

1. Press SLEEP on the Remote Control while playing a source.

The SLEEP indicator blinks on the tuner display.

2. Set the length of time you want the source to play before shutting off.

Each time you press SLEEP while the SLEEP indicator is blinking, it changes the number of minutes shown on the display in the following sequence:

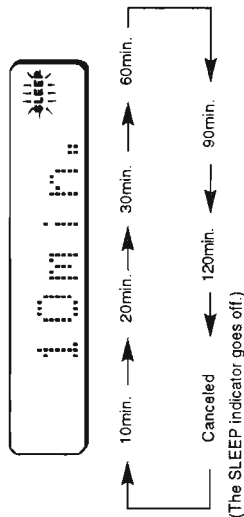

3. When the number of minutes you want is shown on the display, just wait about 5 seconds until the SLEEP indicator stops blinking, and remains lit.

The System is now set to turn off after the number of minutes you set.

To cancel the sleep timer, press SLEEP until the SLEEP indicator goes off on the display. When you turn off the System, the sleep timer is also canceled.

To change the shut-off time, press SLEEP until the number of minutes you want appears on the display.

To check the remaining time, after setting the sleep timer, you can check the time remaining until the System turns off.

Pressing SLEEP shows you the remaining time in minutes on the display for about 5 seconds.

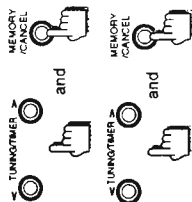

3. Set the time you want the sound source to shut off.

Use TUNING/TIMER < or > and MEMORY/CANCEL just like setting the clock.

4. Select the sound source to play with TUNING/TIMER < or > and MEMORY/CANCEL.

Each time you press TUNING/TIMER < or >, the System gives you one of the following:

- P, - or - ch: Tunes into a preset station
 - CD: Plays a CD from the beginning
 - TAPE: Plays a tape
 - MD: Plays a minidisc recorder from the beginning
- For connecting and operating the minidisc recorder, see page 6 of this manual and the manuals supplied with the minidisc recorder.

- When you select the tuner as the source, you need to designate a preset station by pressing PRESET/PTY < or >.
- When you select TAPE as the source:
 - You need to check that the tape direction is correct. This is important especially when Reverse Mode is off.
 - Deck B has priority, so if tapes are in both decks, the tape in deck B plays first.
- Set Reverse Mode on if you want to play both sides of the tape.

5. Press DAILY again.

The DAILY indicator stops blinking and remains lit. The display, then, shows the settings you have done in step 2 to 4.

- Notice that the DAILY indicator lights up on the display whenever the timer is set, and) the DAILY indicator blinks on the display. When the on-time comes, playback starts using the selected source. When the off-time comes, playback stops and the System automatically turns off.



6. Adjust the volume with the VOLUME control (or VOLUME - or + on the Remote Control).

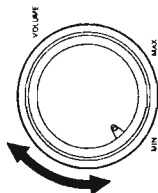

On the front panel

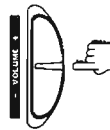

From the Remote Control

To cancel the daily timer, press DAILY so that the DAILY indicator on the display goes off.

To change the timer settings, repeat the setting procedure from the beginning and change the contents as you want.

To erase all the contents stored in the timer:

1. Press DAILY so that on-time for the timer blinks on the display.
2. Hold down MEMORY/CANCEL.
3. Press DAILY again.

Note

If you change the source while the daily timer is operating, the daily timer will be canceled.

CAUTION

If the System is unplugged or if a power failure occurs, the timer setting will be erased. If settings are erased, reset the timer settings.

Care and Maintenance—General Notes

Compact Discs

Handle your compact discs, cassette tapes, and cassette deck carefully, and they will last a long time.

- Remove the CD from the case by holding it at the edges while pressing the center hole lightly.
- Do not touch the shiny surface of the CD, or bend the CD.



- Place the CD into the open tray with the printed side up.



- Put the CD back in its case after use to prevent warping.
- Be careful not to scratch the surface of the CD when placing it back in the case.
- Avoid exposure to direct sunlight, temperature extremes, and moisture.



- A dirty CD may not play correctly. If a CD does become dirty, wipe it with a soft cloth in a straight line from center to edge.



CAUTION
Do not use any solvent (for example, conventional record cleaner, spray, thinner, benzene, etc.) to clean a CD.

Moisture Condensation



Moisture may condense on the lens inside the CD player in the following cases:

- After starting the heating in the room.
- In a damp room.
- If the System is brought directly from a cold to a warm place.

Should this occur, the System may malfunction. In that case, leave the System turned on for a few hours until the moisture evaporates, unplug the AC power cord, and then plug it in again.

In general, you will have the best performance by keeping your tapes, CDs, and the mechanism clean.

- Store tapes and CDs in their cases, and keep them in cabinets or on shelves.
- Keep the cassette holders and the CD tray closed when not in use.

Cassette Tapes



- If the tape is loose in its cassette, take up the slack by inserting a pencil in one of the reels and rotating.
- If the tape is loose it may get stretched, cut, or caught in the cassette.



- Do not touch the tape surface.



- Do not store the tape.
 - In dusty places.
 - In direct sunlight or heat.
 - In moist areas.
 - On a TV or speaker.
 - Near a magnet!

Cassette Deck

- If the heads, capstans, and pinch-rollers of the cassette deck become dirty, the following will occur.

- Impaired sound quality
- Discontinuous sound
- Fading
- Incomplete erasure
- Difficulty in recording

- Clean the heads, capstans, and pinch-rollers using a cotton swab moistened with alcohol.

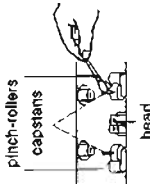

- If the heads become magnetized, they will produce noise or loose high frequencies.

- To demagnetize the heads, turn off the System, and use a head demagnetizer (available at electronics and record shops).

Timer Priority

Since each timer can be set independently, you may have wondered what happens if the settings overlap. Here are the priorities for each timer.

Recording Timer > Sleep Timer > Daily Timer

- The recording timer always has priority. This means that:
 - If the recording and daily timer has the same starting time, the recording timer will be activated.
 - If another timer is set to come on during a time when the recording timer is operating, the other timer just will not come on at all, so you will always get the entire program on a tape.
 - If the recording timer is set to come on while another timer is operating, the other timer will shut off about 10 seconds before the recording timer is set to come on, and the recording timer will then take over.

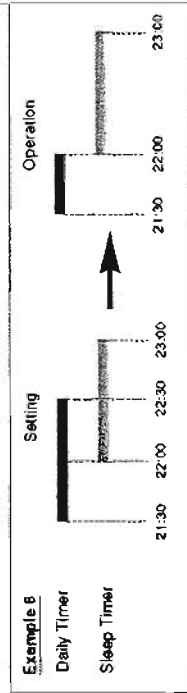
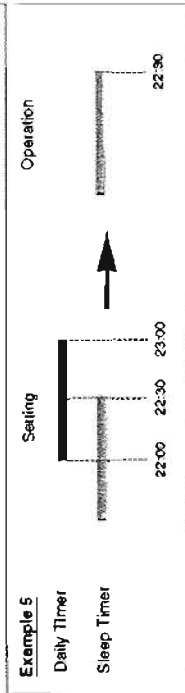
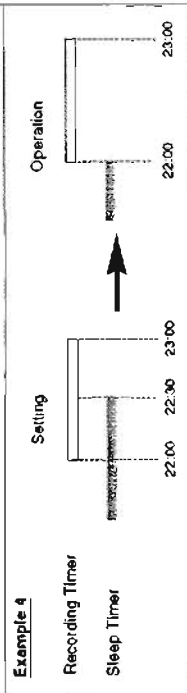
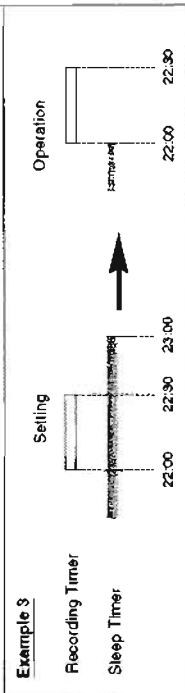
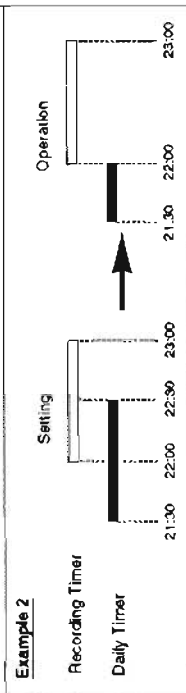
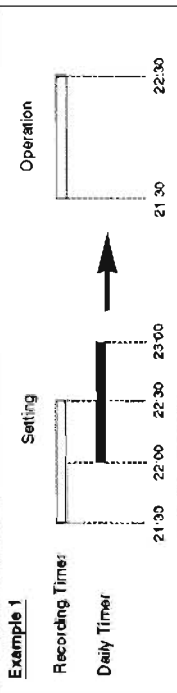

Troubleshooting

- If you are having a problem with your System, check this list for a possible solution before calling for service.
- If you cannot solve the problem from the hints given here, or the System has been physically damaged, call a qualified person, such as your dealer, for service.

Symptom	Possible Cause	ACTION
No sound is heard.	Connections are incorrect, or loose.	Check all connections and make corrections. (See pages 4 to 6.)
Impossible to record.	Cassette record protect tabs are removed.	Cover holes on back edge of cassette with tape.
Hard to listen to broadcasts because of noise.	The antenna is disconnected. The loop antenna is too close to the system.	Reconnect the antenna securely. Change the position and direction of the loop antenna.
The CD sound is discontinuous.	The wire antenna is not properly extended and positioned.	Extend wire antenna at the best reception position.
Unable to operate the Remote Control.	The CD is scratched or dirty. The path between the Remote Control and the sensor on the front panel is blocked. The batteries are discharged.	Clean or replace the CD. Remove the obstruction. Replace the batteries.
The CD tray cannot be operated.	The AC power cord is not plugged in.	Plug in the AC power cord.
The CD does not play.	The CD is upside down.	Put the CD in with the printed side up.
Operations are disabled.	The built-in microprocessor may malfunction due to external electrical interference.	Unplug the System then plug it back in.
The cassette holder cannot be opened.	The System was turned off because the tuner was operated while the tape was running.	Turn on the System.
The FM station tuned alternates between the currently selected one and another when using the EON Standby reception.	An incorrect EON signal is being sent.	Press EON ON/OFF to cancel the EON Standby reception.

Specifications

Integrated Amplifier AX-F3000

Output Power (IEC 268-3/DIN)
Front Speakers
40 watts per channel, min. RMS, both channels driven, into 4 ohms at 1 kHz with no more than 0.9% total harmonic distortion.

Input Sensitivity/Impedance (1 kHz)

MD
AUX
PHONO

Output Load/Impedance (1 kHz)

MD

Speaker Impedance

Power Requirements

Power Consumption

Dimensions (Approx.)

Mass (Approx.)

610 mV/50 kohms
300 mV/50 kohms
3.0 mV/47 kohms
260 mV/380 ohms
4 – 16 ohms
AC 230 V_v, 50 Hz
140 watts
11 watts (in standby mode)
245 x 120 x 328 mm (w/h/d)
(9 11/16 x 4 3/4 x 12 15/16 in.)
5.1 kg (11.3 lbs)

FMMW/LW Tuner EX-F3000R

FM Tuner

Tuning Range

87.5 – 108.0 MHz

522 – 1,629 kHz

144 – 288 kHz

245 x 81 x 303 mm (w/h/d)

Dimensions (Approx.)

Mass (Approx.)

1.7 kg (3.8 lbs)

Double Cassette Deck ID-F3000

Frequency Response

Metal (Type IV):

CrO₂ (Type II):

Normal (Type I):

Wow and Flutter

Dimensions (Approx.)

Mass (Approx.)

3.0 kg (6.7 lbs)

30 – 17,000 Hz

30 – 16,000 Hz

30 – 15,000 Hz

0.09% (WRMS) 0.2% (DIN)

245 x 120 x 292 mm (w/h/d)

Dimensions (Approx.)

Mass (Approx.)

3.0 kg (6.7 lbs)

Compact Disc Player XL-F3000

Wow and Flutter

Unmeasurable

Digital output

OPTICAL DIGITAL OUT

Dimensions (Approx.)

245 x 81 x 300 mm (w/h/d)

Mass (Approx.)

2.2 kg (4.9 lbs)

Supplied Accessories

FM Wire Antenna (1)

AM (M/W/LW) Loop Antenna (1)

Remote Control (1)

Batteries (2)

External Wire (1)

Design and specifications are subject to change without notice.

— MEMO —

AX-F3000

**Note: Press S510 on ENH-296-1 for checking only AX-F3000 unit or units
except FX-F3000/FX-F3000R.
Discharge C404 after services.**

Contents

<i>Description of Major ICs</i>	2-2
<i>Disassembly Procedures</i>	2-5
<i>Adjustment Procedures</i>	2-8
<i>Block Diagram</i>	2-9
<i>Printed Circuit Boards</i>	2-10
<i>Schematic Diagrams</i>	2-13

Description of Major LSIs

■ MN171202J6S (IC501) : System controller

Terminal Layout

VDD	1	64	OSC IN
CD.IND	2	63	OSC OUT
TUNER.IND	3	62	GND
TAPE.IND	4	61	
MD.IND	5	60	
PHONO.IND	6	59	
AUX.IND	7	58	POWER ON
POWER ON.IND	8	57	SPK-RELAY
VOLUME.IND	9	56	MUTE
DIRECT.IND	10	55	DIRECT ON/OFF
PRESENCE.IND	11	54	PRESENCE
	12	53	VOL.DOWN
	13	52	VOL.UP
	14	51	H.P.IN
	15	50	P.CONT
	16	49	
	17	48	
GND	18	47	
	19	46	PROTECT IN
	20	45	INH
	21	44	RM IN
	22	43	RESET
	23	42	DATA
	24	41	STB
	25	40	SCLK
	26	39	AUX KEY
DCS IN	27	38	PHONO KEY
DCS OUT	28	37	MD KEY
	29	36	
AX PON	30	35	
DIRECT KEY IN	31	34	
POWER KEY IN	32	33	PRESENCE KEY

KEY SW. INPUT

Symbol	Function
S501	PRESENCE
S502	CD DIRECT
S503	POWER
S507	MD
S508	PHONO
S509	AUX
S510	AX POWER

Terminal Description

Pin No.	Symbol	I/O	Function	Pin NO.	Symbol	I/O	Function
1	VDD	--	Power supply	33	PRESENCE KEY	I	PRESENCE key input
2	CD.IND	O	Indicator signal output	34		--	Pull up
3	TUNER.IND	O	Indicator signal output	35		--	Pull up
4	TAPE.IND	O	Indicator signal output	36		--	Pull up
5	MD.IND	O	Indicator signal output	37	MD KEY	I	MD key input
6	PHONO.IND	O	Indicator signal output	38	PHONO KEY	I	PHONO key input
7	AUX.IND	O	Indicator signal output	39	AUX	I	AUX key input
8	POWER ON.IND	O	Indicator signal output	40	SCLK	O	Switth clock signal input
9	VOLUME.IND	O	Indicator signal output	41	STB	O	Switth strobe signal input
10	DIRECT.IND	O	Indicator signal output	42	DATA	O	Switth data signal input
11	PRESENCE.IND	O	Indicator signal output	43	RESET	I	Reset signal input
12		--	Pull up	44	RM IN	I	Remort control signal input
13		--	Pull up	45	INH	I	Inhbit signal input
14		--	Pull up	46	PROTECT IN	I	PROTECT control signal input
15		--	Pull up	47		--	GND
16		--	Pull up	48		--	GND
17		--	Pull up	49		--	GND
18	GND	--	GND	50	P.CONT	O	DECK power control signal
19		--	Pull up	51	H.P.IN	I	H.P. ON/OFF control signal
20		--	Pull up	52	VOL.UP	O	VOL. up control signal
21		--	Pull up	53	VOL.DOWN	O	VOL. down control signal
22		--	Pull up	54	PRESENCE	O	PRESENCE ON/OFF control signal
23		--	Pull up	55	DIRECT ON/OFF	O	CD DIRECT ON/OFF control signal
24		--	Pull up	56	MUTE	O	SOURCE MUTE control signal
25		--	Pull up	57	SPK-RELAY	O	SPK-RELAY control signal
26		--	Pull up	58	POWER ON	O	POWER ON/OFF control signal
27	DCS IN	I	Compulink input	59		--	GND
28	DCS OUT	O	Compulink output	60		--	GND
29		--	Pull up	61		--	Not used
30	AX PON	I	AX-F3000 Power on key input	62	GND	--	GND
31	DIRECT KEY IN	I	CD DIRECT key input	63	OSC OUT	O	Oscillation terminal
32	POWER KEY IN	I	POWER keyinput	64	OSC IN	I	Oscillation terminal

■ VC5022-2(IC751,752) :SUPER A

1. Terminal Layout

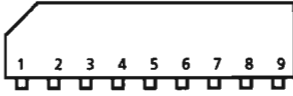

2. Block Diagram

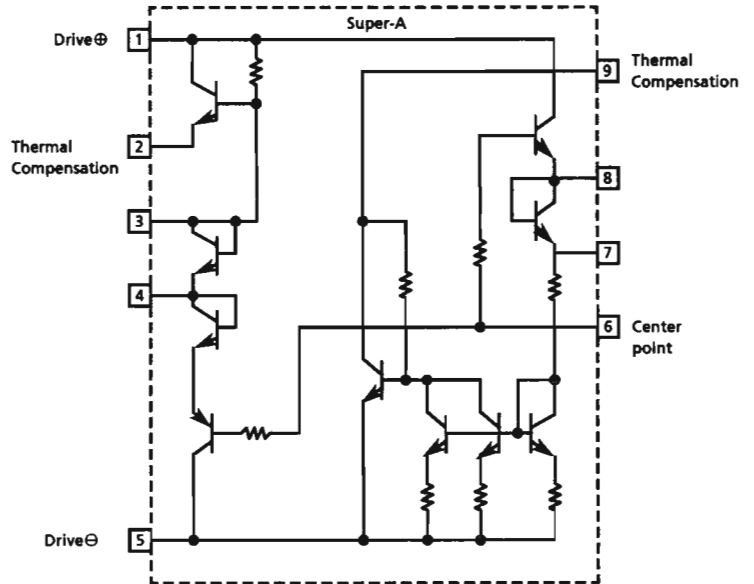

■ LB1639-CV (IC351) : DC Motor driver

1. Terminal Layout

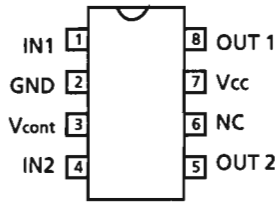

2. Block Diagram

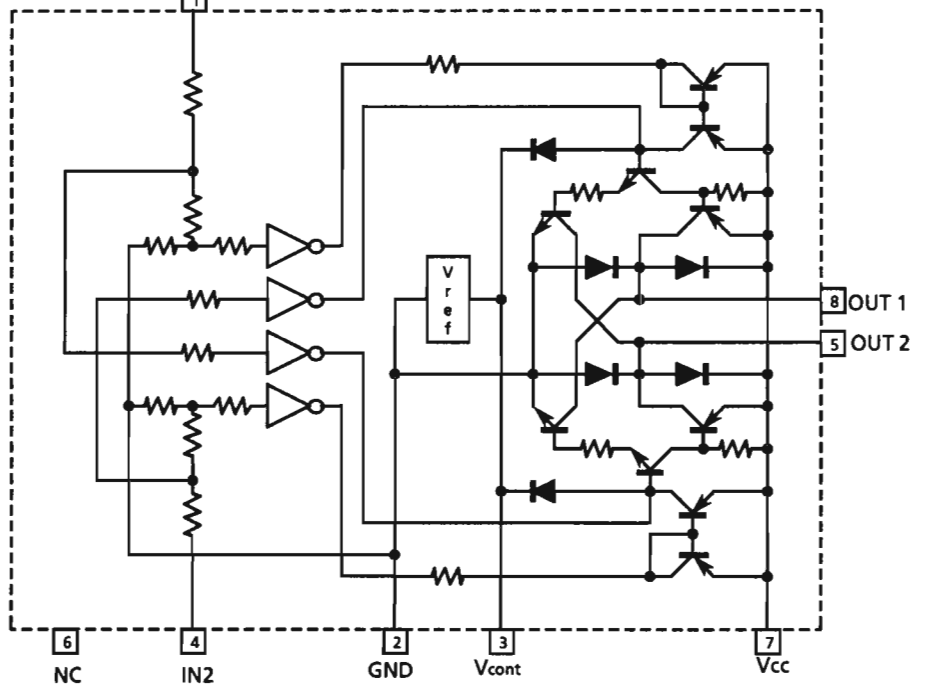

Pin Functions

IN 1	IN 2	OUT 1	OUT 2	MOTOR
H	L	H	L	CLOCKWISE
L	H	L	H	COUNTER-CLOCKWISE
H	H	OFF	OFF	WAITING
L	L	OFF	OFF	WAITING

AX-F3000

■ NJH32H380A (IC502) : Remocon Module IC

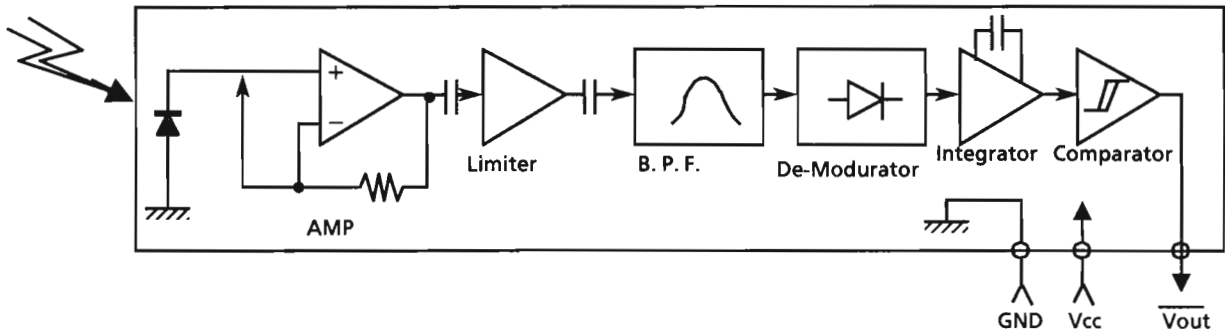

■ NJM4580DD (IC101), NJM4558 (IC363) VC4580DD (IC231,301,361) : Dual OP Amp.

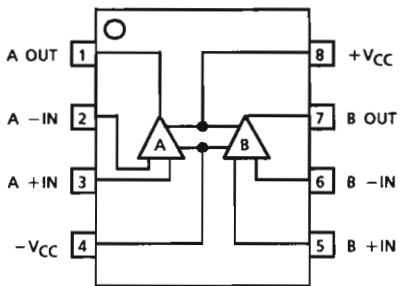

Disassembly Procedures

(1) Removing the top cover

1. Remove 2 screws **A** fastening both sides of top cover, and 4 screws **B** fastening the rear side.
2. Remove the top cover.

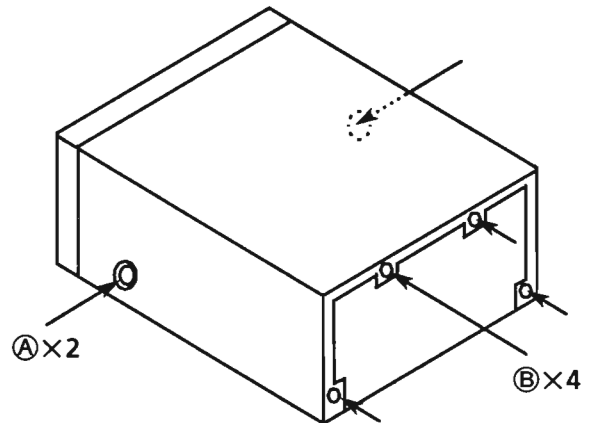

(2) Removing the Front Panel Assembly

1. Remove the top cover.
2. Pull out the Master volume knob, and Remove the nut fastening the Master volume.
3. Cut the tie band, and Disconnect the connectors (CN201,CN203)
4. Remove 2 screws **C** and 2 hooks **a** fastening bottom of the front panel assembly.

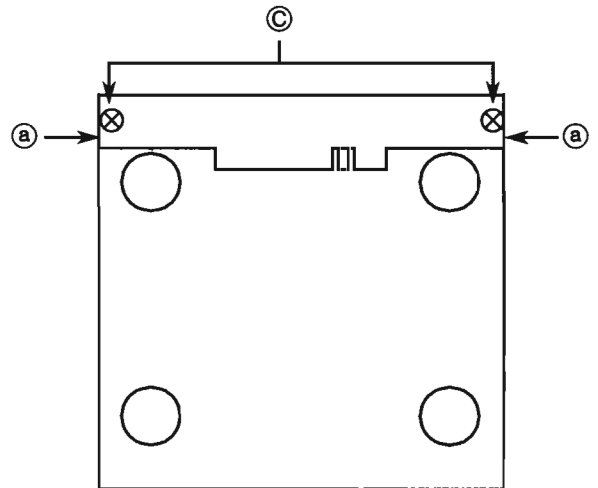

(3) Removing the Control PCB (ENB-241-1)

1. Remove the top cover.
2. Remove the front panel assembly.
3. Pull out the Treble knob, Bass knob and Balance knob.
4. Remove 10 screws **D** fastening the control PCB to remove it.

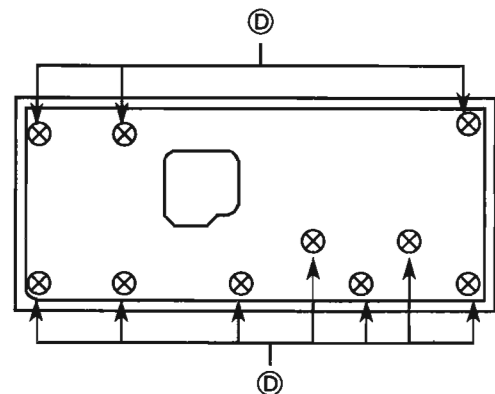

A ... SDSG3008N **B** ... GBSG3008CC **C** ... SDSG3008CC **D** ... SDSF2608Z

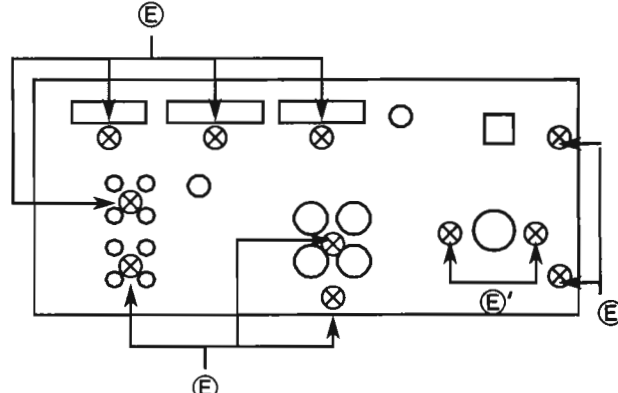
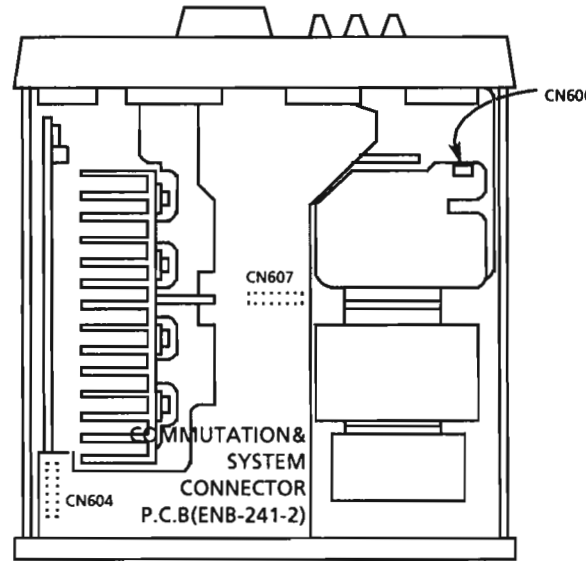
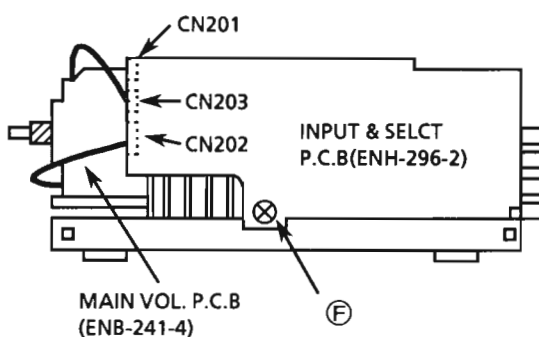
<p>(4) Removing the Rear panel</p> <ol style="list-style-type: none"> 1. Remove the top cover. 2. Remove the 9 screws (E). (Universal type: Remove the 2 screws (E')) 3. Remove the rear panel. 	
<p>(5) Removing the Commutation & system connector P.C.B(ENB-241-2)</p> <ol style="list-style-type: none"> 1. Remove the top cover. 2. Remove the rear panel. 3. Disconnect the CN606, CN607, CN604. 4. Remove the Commutation & system connector P.C.B. 	
<p>(6) Removing the Input & select P.C.B (ENH-296-2)</p> <ol style="list-style-type: none"> 1. Remove the top cover and front panel ass'y. 2. Remove the rear panel. 3. Remove the Commutation & system connector P.C.B. 4. Remove the a screw (F). 	
<p>(E) .. E73273-003 (F) ... SBSG3008CC</p>	

(7) Removing the Main P.C.B (ENH-296-1)

1. Remove the top cover and front panel ass'y.
2. Remove the rear panel.
3. Remove the Commutation & system connector P.C.B.
4. Remove the 2 screws ⑥ holding the main P.C.B, and the 4 screws ③ holding the heat sink bracket.
5. Remove the heat sink with the main P.C.B.

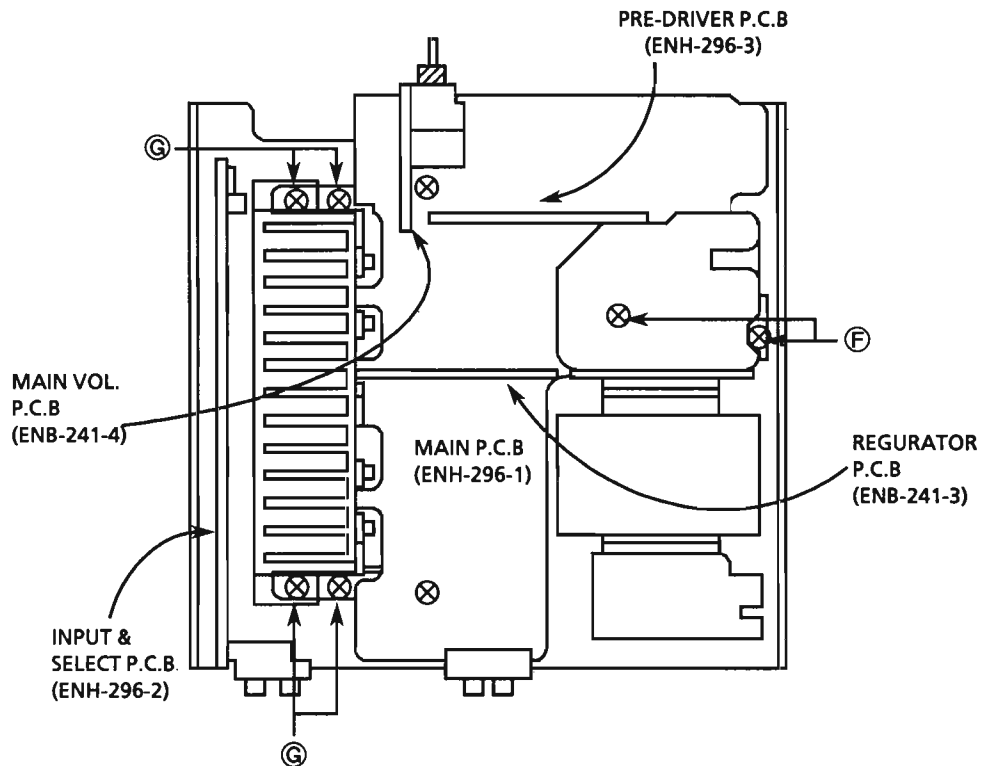

⑥ .. SBSG3008CC ③ ... SBST3006CC

ADJUSTMENT PROCEDURES

■ Idling Current

- (1) Set the volume control to minimum during this adjustment.
- (2) Turn R751 and R752 fully counterclockwise before the power is switch on.
- (3) Always start from cold, and allow 5 minutes to warm up before adjustment.
If the heatsink is already warm from previous use the correct adjustment can not be made.
- (4) Connect a DC voltmeter to R771 resistor's leads for left channel, or to R772 for right channel.
- (5) Adjust R751 for left channel, or R752 for right channel, so that the DC voltmeter becomes 2.2 mV ~ 22mV.

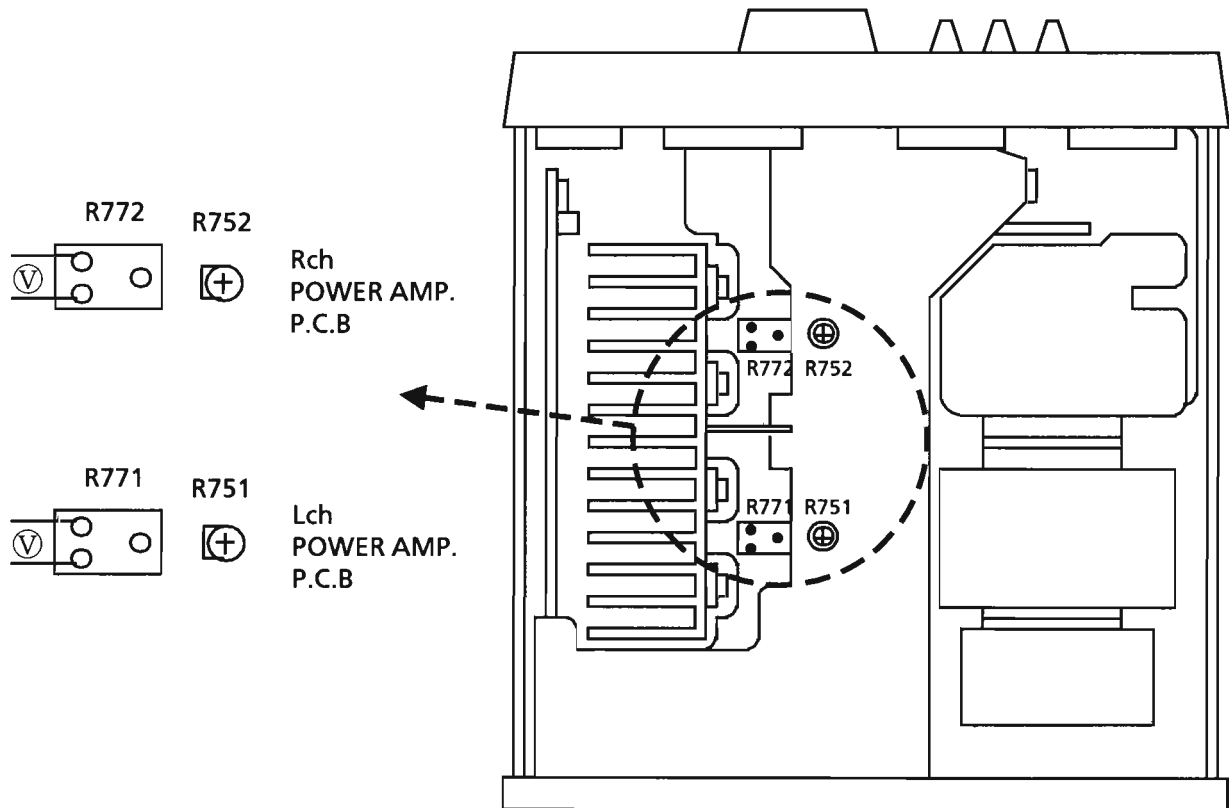

Block Diagram

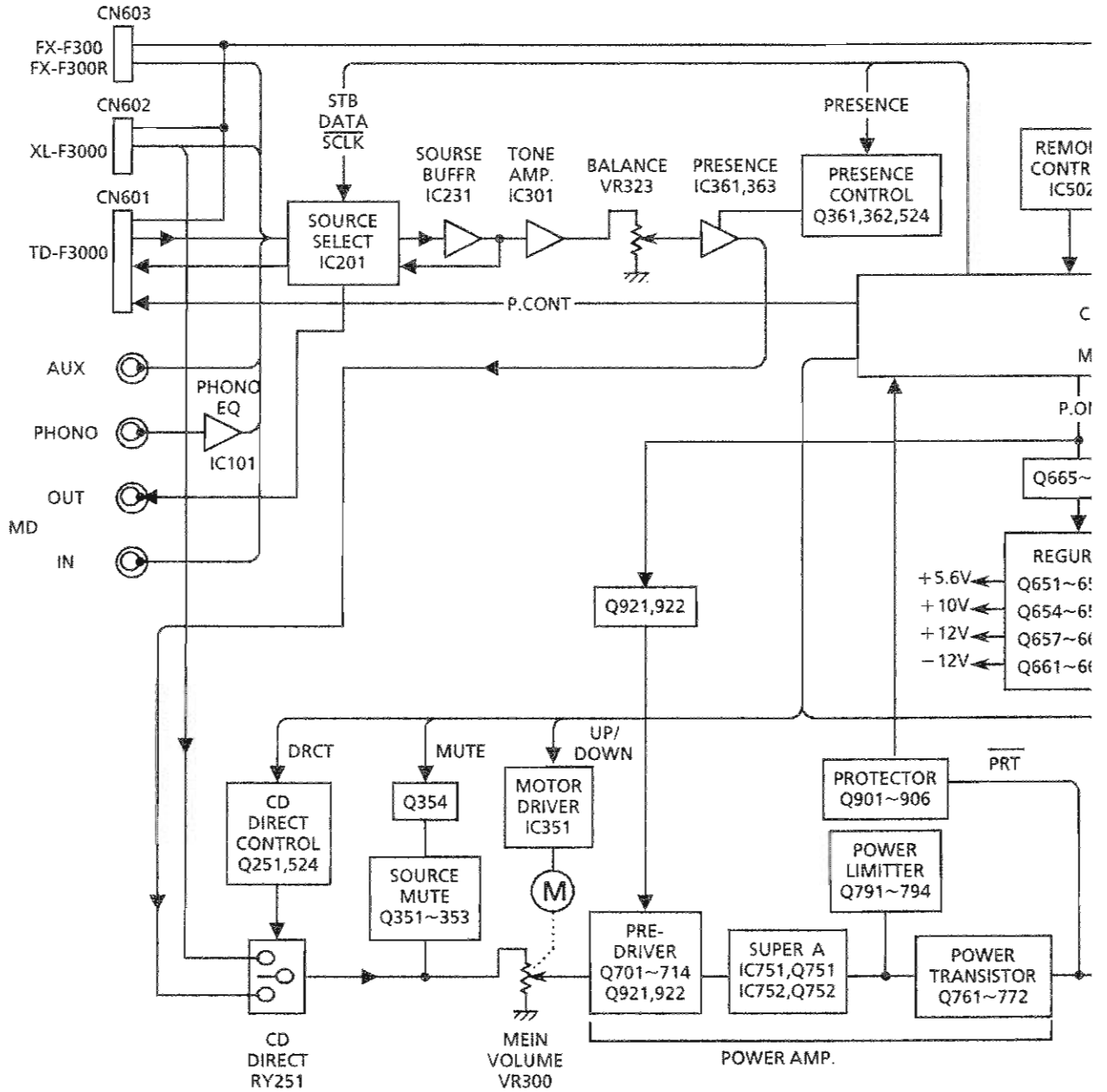

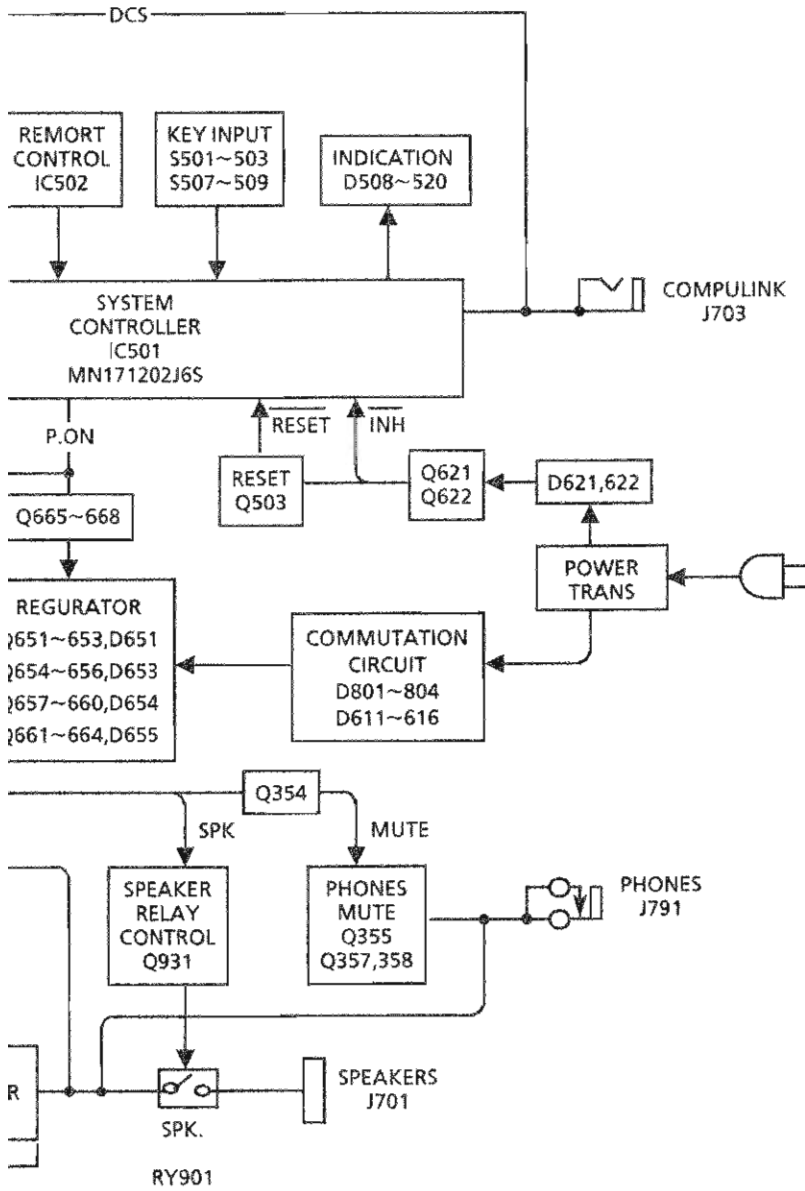

Printed Circuit Boards

- Power Supply P.C.B(END-104)

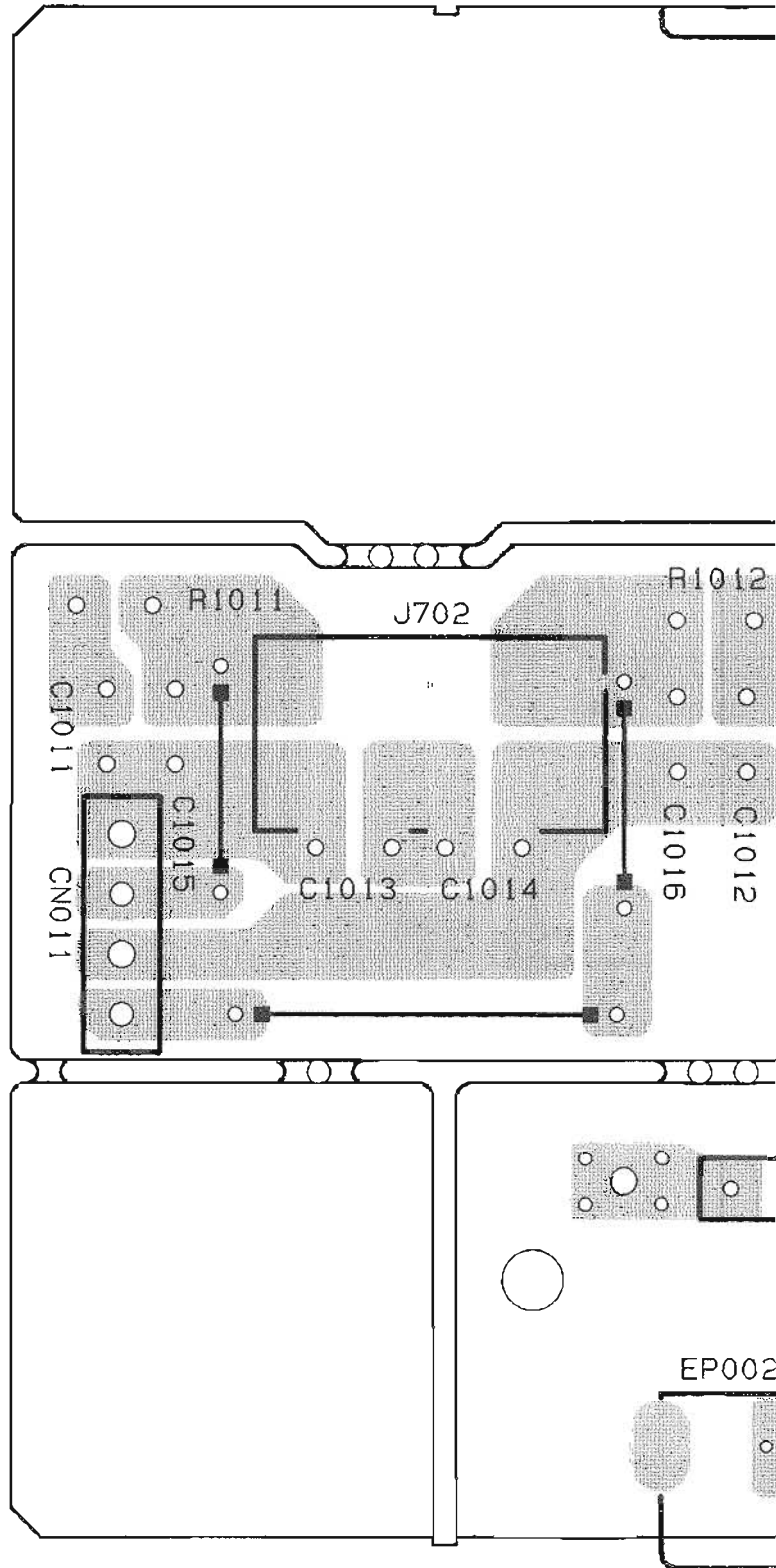

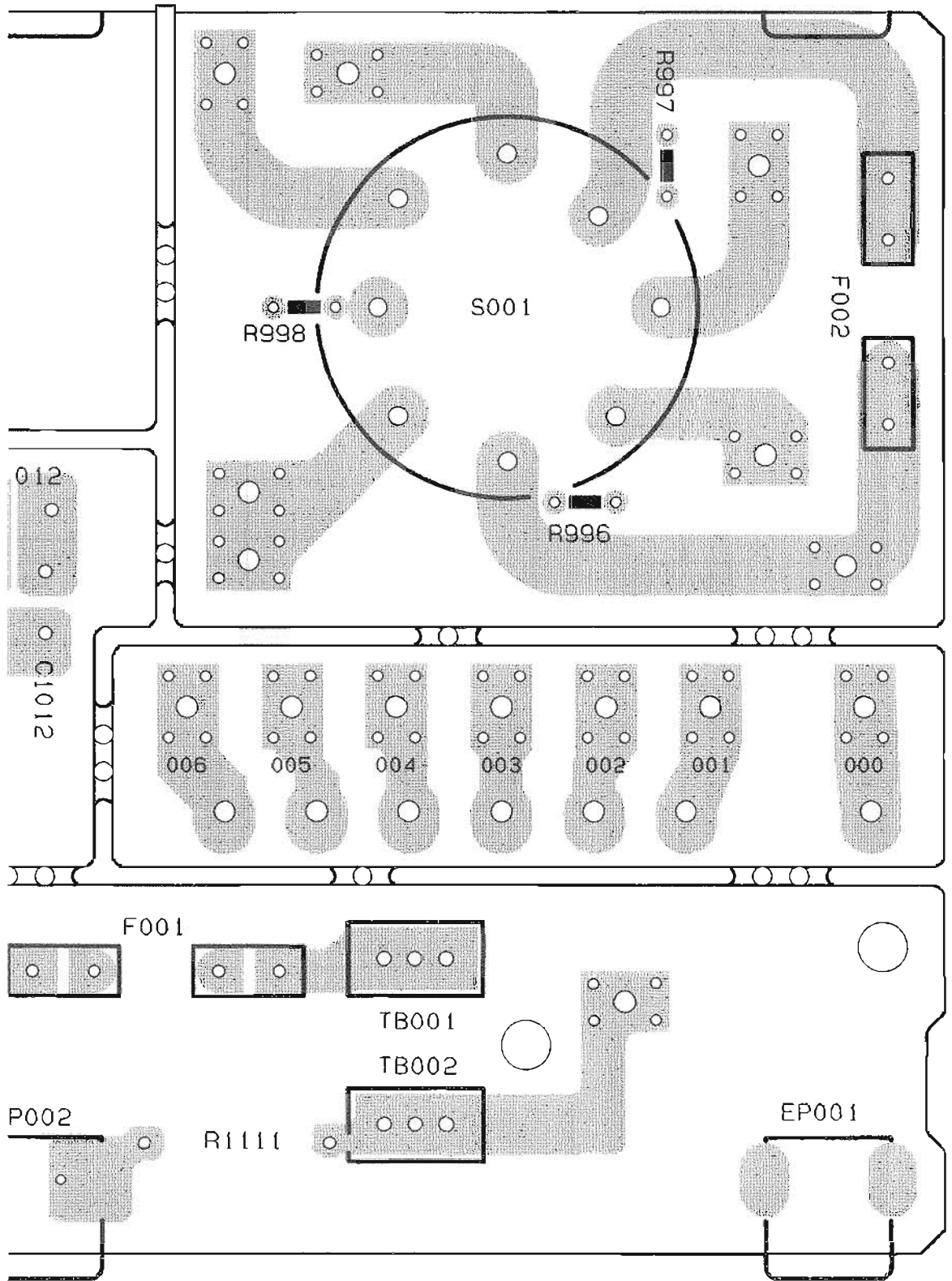

P2-11-a

P2-11-b

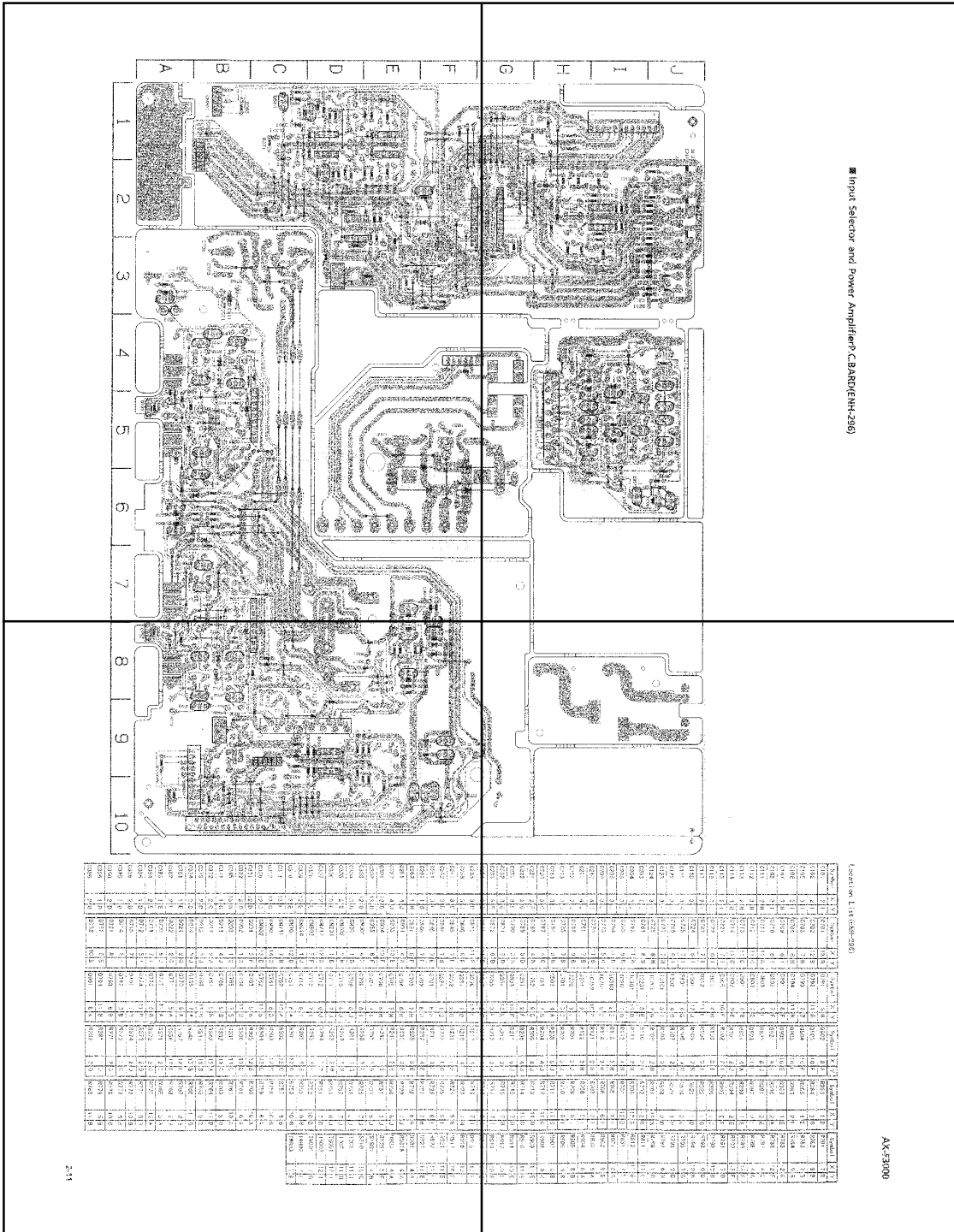

P2-11-c

P2-11-d

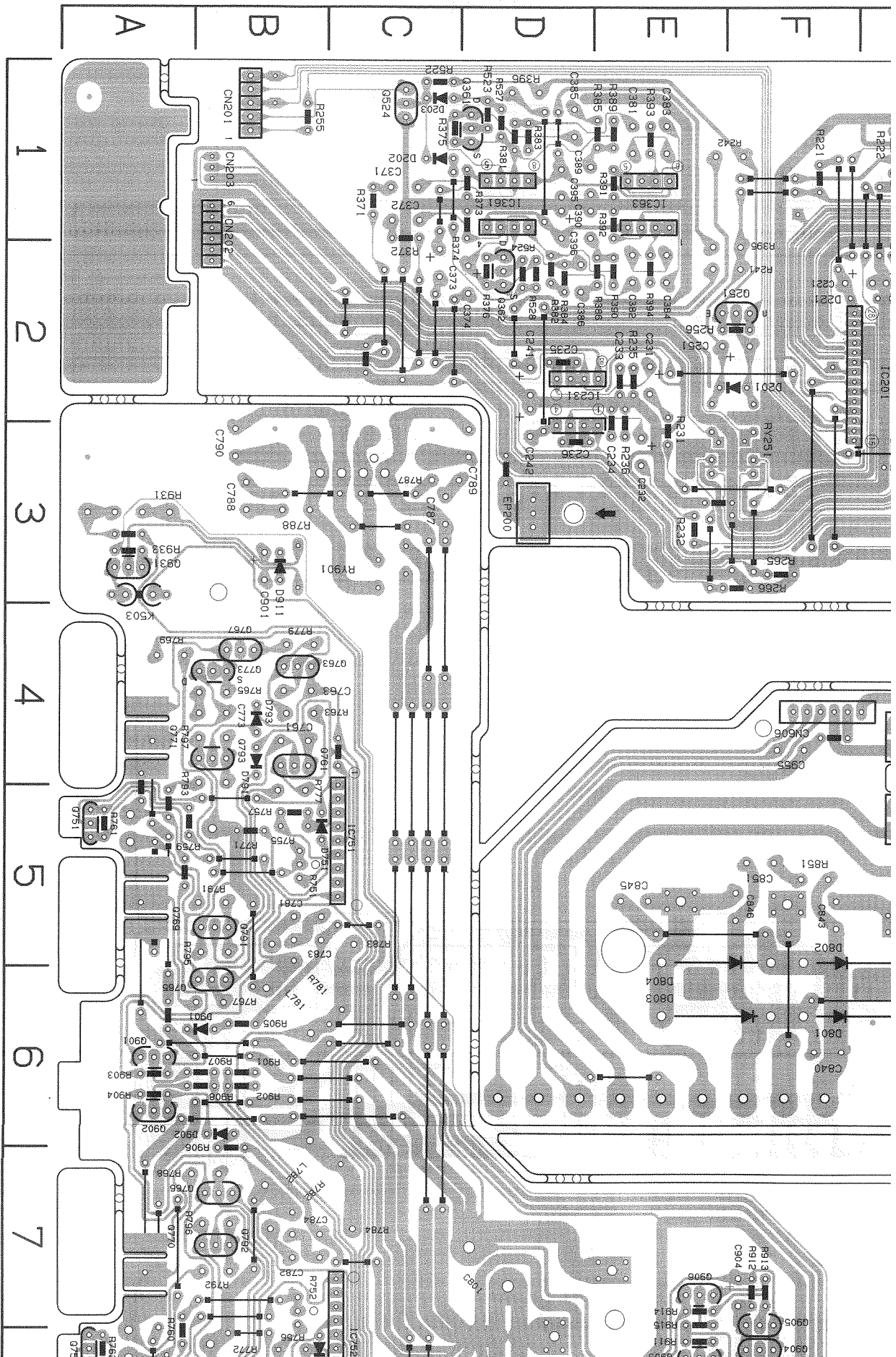

Input Selector and Power Amplifier P.C. BOARD (ENH-296)

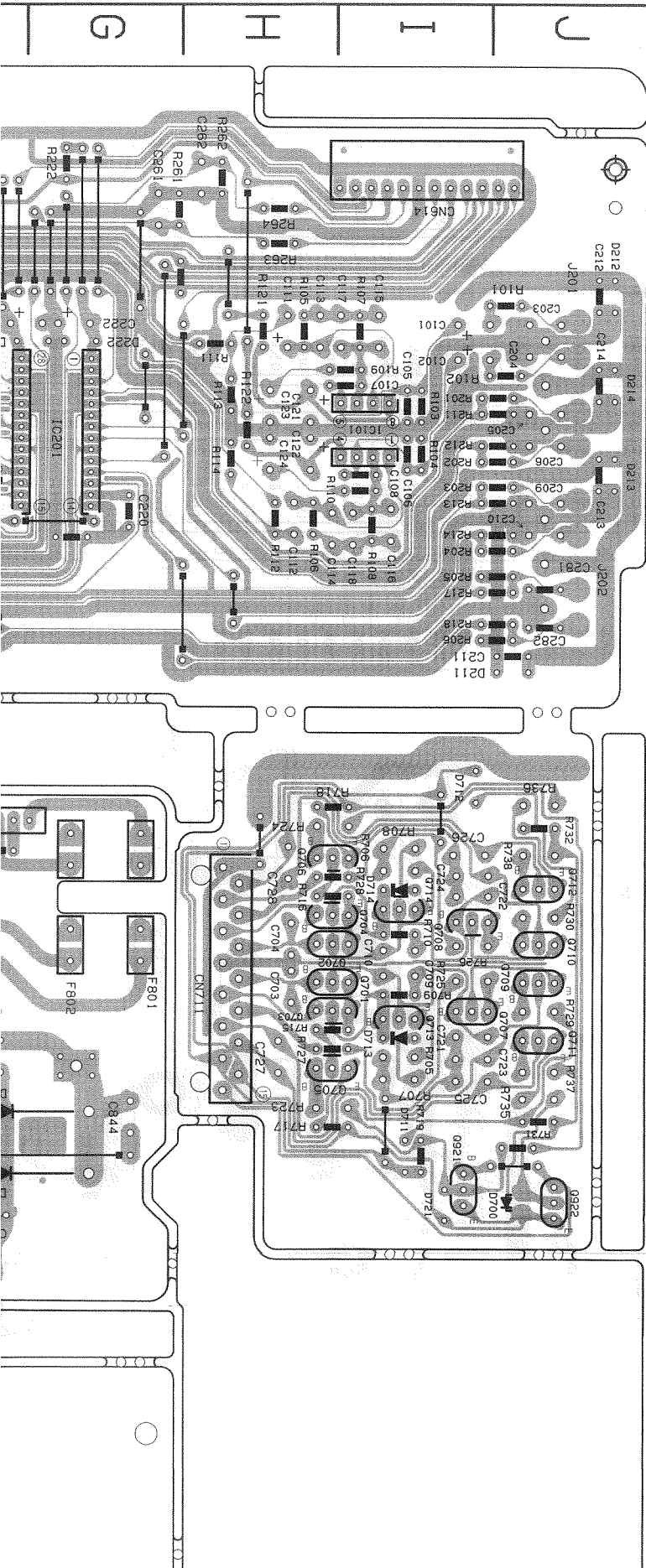

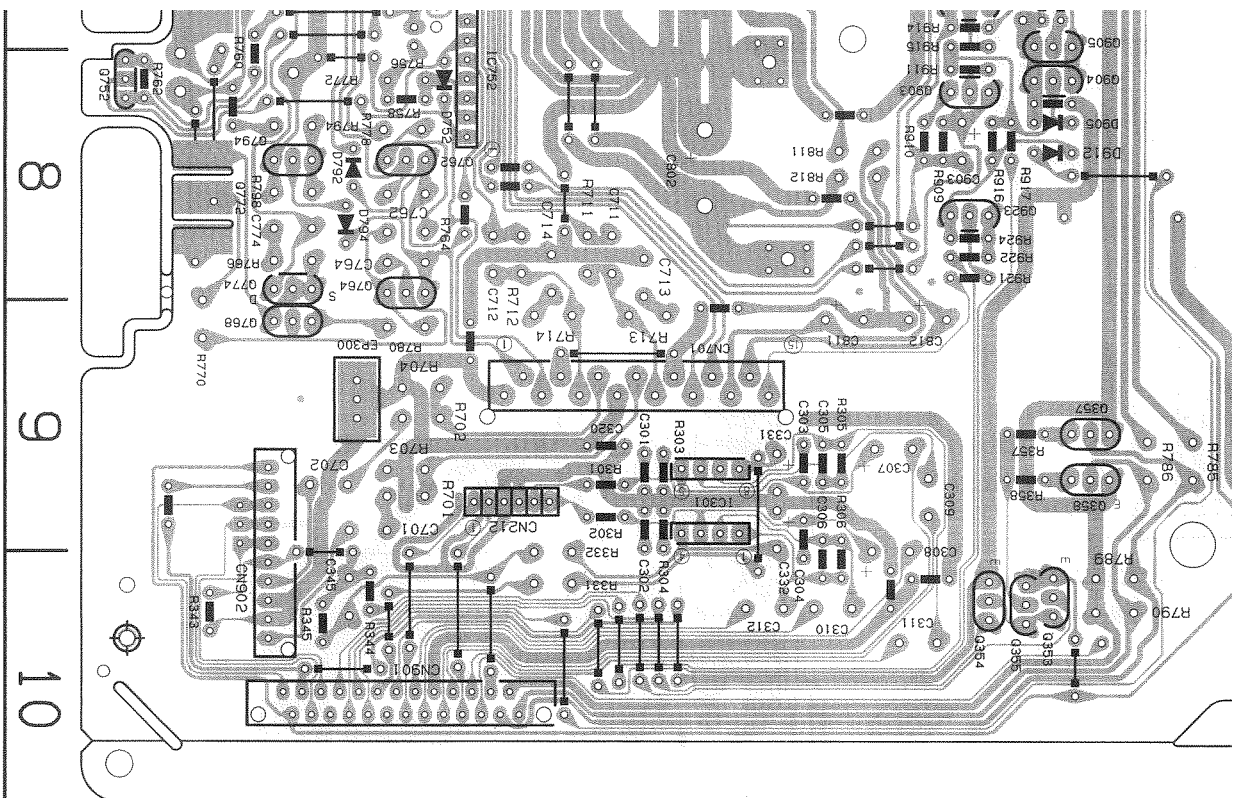

C234	3 E	C811	11 E	Q357	12 F	R214	4 I	R718	5 I	R914	10 E
C235	3 D	C812	11 E	Q358	12 F	R217	4 J	R719	7 I	R915	10 E
C236	3 D	C840	8 F	Q361	1 D	R218	4 I	R723	7 H	R916	10 E
C241	3 D	C843	7 F	Q362	2 D	R221	1 F	R724	5 H	R917	10 F
C242	3 D	C844	7 G	Q524	1 C	R222	1 G	R725	6 I	R921	11 E
C251	3 E	C845	7 E	Q701	6 H	R231	3 E	R726	6 I	R922	11 E
C261	1 G	C846	7 F	Q702	6 H	R232	4 E	R727	7 H	R924	11 E
C282	1 H	C851	6 F	Q703	7 H	R235	3 E	R728	6 H	R931	4 A
C281	4 J	C901	4 B	Q704	6 H	R236	3 E	R729	7 J	R931A	4 A
C282	4 J	C903	10 E	Q705	7 H	R241	2 E	R730	6 J	R933	4 A
C301	12 D	C904	10 F	Q706	6 H	R242	1 E	R731	7 J	R9251	3 F
C302	13 D	C955	6 F	Q707	7 I	R255	1 B	R732	5 J	PY901	4 B
C303	12 D	CN001	4 C	Q708	6 I	R256	3 E	R735	7 J	SS10	13 G
C304	13 D	CN201	1 B	Q709	6 J	R261	1 G	R736	5 J	T001	11 I
C305	12 E	CN202	2 B	Q710	6 J	R262	1 H	R737	7 J	T002	11 H
C306	13 E	CN203	1 B	Q711	7 J	R263	2 H	R738	6 J	TB001	12 I
C307	12 E	CN212	12 C	Q712	6 J	R264	1 H	R751	7 B	TB002	12 I
C308	13 E	CN606	5 F	Q713	7 I	R265	4 F	R752	10 B	TW801	7 G
C309	12 E	CN614	1 J	Q714	6 I	R266	4 E	R755	6 B	TW802	7 F
C310	13 E	CN701	12 D	Q751	6 A	R301	12 C	R756	10 B	TW803	7 E
C311	13 E	CN711	7 H	Q752	10 A	R302	12 C	R757	6 B		
C312	13 D	CN901	14 C	Q761	6 B	R303	12 D	R758	10 B		
C320	12 C	CN902	13 B	Q762	11 B	R304	12 D	R759	6 A		
C331	12 D	D201	3 F	Q763	5 B	R305	12 E	R760	10 A		
C332	12 D	D202	1 C	Q764	11 B	R306	13 E	R761	6 A		
C345	13 B	D203	1 C	Q765	7 B	R331	13 C	R762	10 A		
C371	1 C	D211	4 J	Q766	9 B	R332	13 C	R763	5 B		
C372	2 C	D212	2 J	Q767	5 B	R343	13 A	R764	11 B		
C373	2 C	D213	3 J	Q768	11 B	R344	13 B	R765	5 B		
C374	2 D	D214	3 J	Q769	7 A	R345	13 B	R766	11 B		
C381	1 E	D221	2 G	Q770	9 A	R357	12 F	R767	8 B		
C382	2 E	D222	2 G	Q771	5 A	R358	12 F	R768	9 B		
C383	1 E	D700	8 J	Q772	11 A	R371	2 C	R769	5 A		
C384	2 E	D711	7 I	Q773	5 B	R372	2 C	R770	12 A		
C385	1 D	D712	5 I	Q774	11 B	R373	2 D	R771	6 B		
C386	2 D	D713	7 I	Q791	7 B	R374	2 D	R772	10 B		
C389	1 D	D714	6 I	Q792	9 B	R375	1 C	R777	6 B		
C390	2 D	D721	8 I	Q793	6 B	R376	2 D	R778	10 B		
C395	1 D	D751	6 B	Q794	11 B	R381	1 D	R779	5 B		
C396	2 D	D752	10 B	Q901	8 A	R382	2 D	R780	11 B		

Location List (ENH-296)

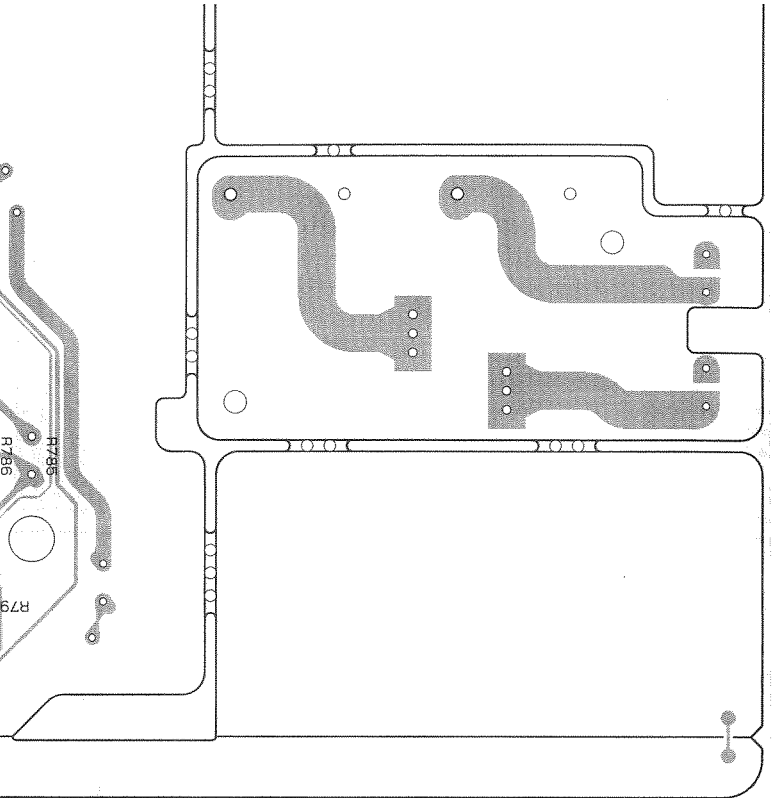

Symbol	X	Y	Symbol	X	Y	Symbol	X	Y	Symbol	X	Y	Symbol	X	Y	Symbol	X	Y
C101	2	I	C701	13	B	D791	6	B	Q902	8	A	R833	1	D	R781	7	B
C102	2	I	C702	12	B	D792	11	B	Q903	10	E	R384	2	D	R782	9	B
C105	3	I	C703	7	H	D793	6	B	Q904	10	F	R385	1	E	R783	7	B
C106	3	I	C704	6	H	D794	11	B	Q905	10	F	R386	2	E	R784	9	B
C107	3	H	C709	6	I	D801	8	F	Q906	10	E	R389	1	E	R785	12	G
C108	3	I	C710	6	I	D802	7	F	Q921	8	I	R390	2	E	R786	12	F
C111	2	H	C711	11	C	D803	8	E	Q922	8	J	R391	2	E	R787	4	C
C112	3	H	C712	11	C	D804	7	E	Q923	11	E	R392	2	E	R788	4	B
C113	2	H	C713	11	D	D901	8	B	Q931	4	A	R393	1	E	R789	13	F
C114	4	H	C714	11	C	D902	9	B	R101	2	J	R394	2	E	R790	13	F
C115	2	I	C721	7	I	D905	10	F	R102	2	I	R395	2	F	R791	7	B
C116	3	I	C722	6	I	D911	4	B	R103	3	I	R396	1	D	R792	10	B
C117	2	I	C723	7	I	D912	11	F	R104	3	I	R522	1	C	R793	6	B
C118	3	I	C724	6	I	F001	12	J	R105	2	H	R523	1	D	R794	10	B
C121	3	H	C725	7	I	F801	6	G	R106	4	H	R524	2	D	R795	7	B
C122	3	H	C726	6	I	F802	6	G	R107	2	I	R527	1	D	R796	9	B
C123	3	H	C727	7	H	IC101	3	I	R108	3	I	R528	2	D	R797	6	B
C124	3	H	C728	6	H	IC201	2	G	R109	2	H	R701	12	B	R798	11	B
C203	2	J	C761	6	B	IC231	3	E	R110	3	I	R702	12	B	R811	11	E
C204	2	J	C762	11	B	IC301	13	D	R111	2	H	R703	12	B	R812	11	E
C205	3	J	C763	5	B	IC361	2	D	R112	4	H	R704	12	B	R851	7	F
C206	3	J	C764	11	B	IC363	2	E	R113	3	H	R705	7	I	R901	8	B
C209	3	J	C773	5	B	IC751	6	C	R114	3	H	R706	6	I	R902	8	B
C210	4	J	C774	11	B	IC752	10	C	R121	2	H	R707	7	I	R903	8	A
C211	4	J	C781	7	B	J201	2	J	R122	3	H	R708	6	I	R904	8	A
C212	2	J	C782	9	B	J202	3	J	R201	3	J	R709	6	I	R905	8	B
C213	3	J	C783	7	B	J701	3	C	R202	3	J	R710	6	I	R906	9	B
C214	3	J	C784	9	B	K503	4	A	R203	3	J	R711	11	C	R907	8	B
C220	3	G	C787	4	C	L781	7	B	R204	4	J	R712	11	C	R908	8	B
C221	2	F	C788	4	B	L782	9	B	R205	4	J	R713	11	D	R909	11	E
C222	2	G	C789	3	D	Q251	2	F	R206	4	J	R714	11	C	R910	11	E
C231	3	E	C790	3	B	Q353	13	F	R211	3	J	R715	7	H	R911	10	E
C232	3	E	C801	9	D	Q354	13	E	R212	3	I	R716	6	H	R912	10	F
C233	3	E	C802	10	D	Q355	13	F	R213	3	J	R717	7	I	R913	10	F
C234	3	E	C811	11	E	Q357	12	F	R214	4	I	R718	5	I	R914	10	E
C235	3	D	C812	11	E	Q358	12	F	R217	4	J	R719	7	I	R915	10	E

P2-12-a

P2-12-b

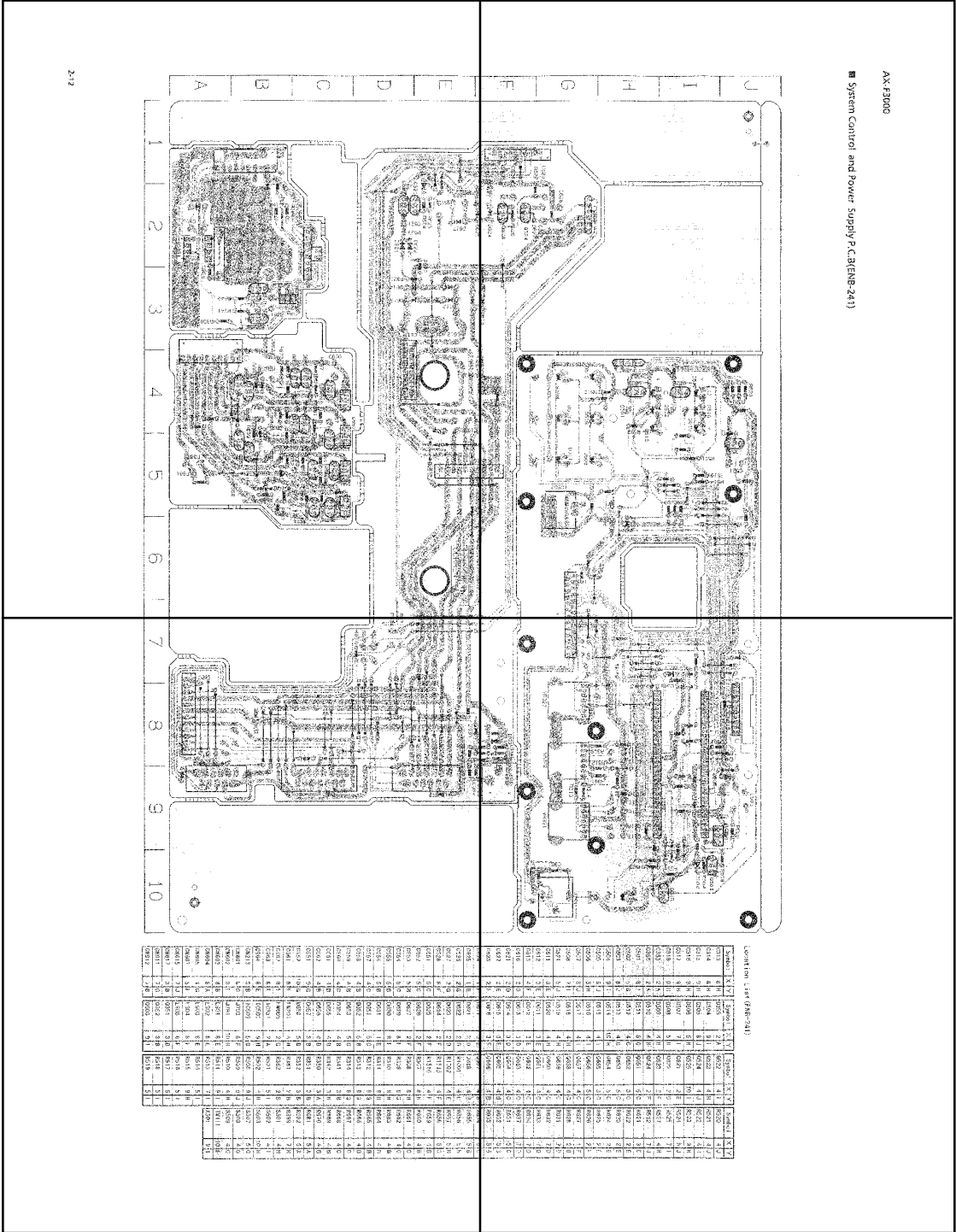

2412

P2-12-c

P2-12-d

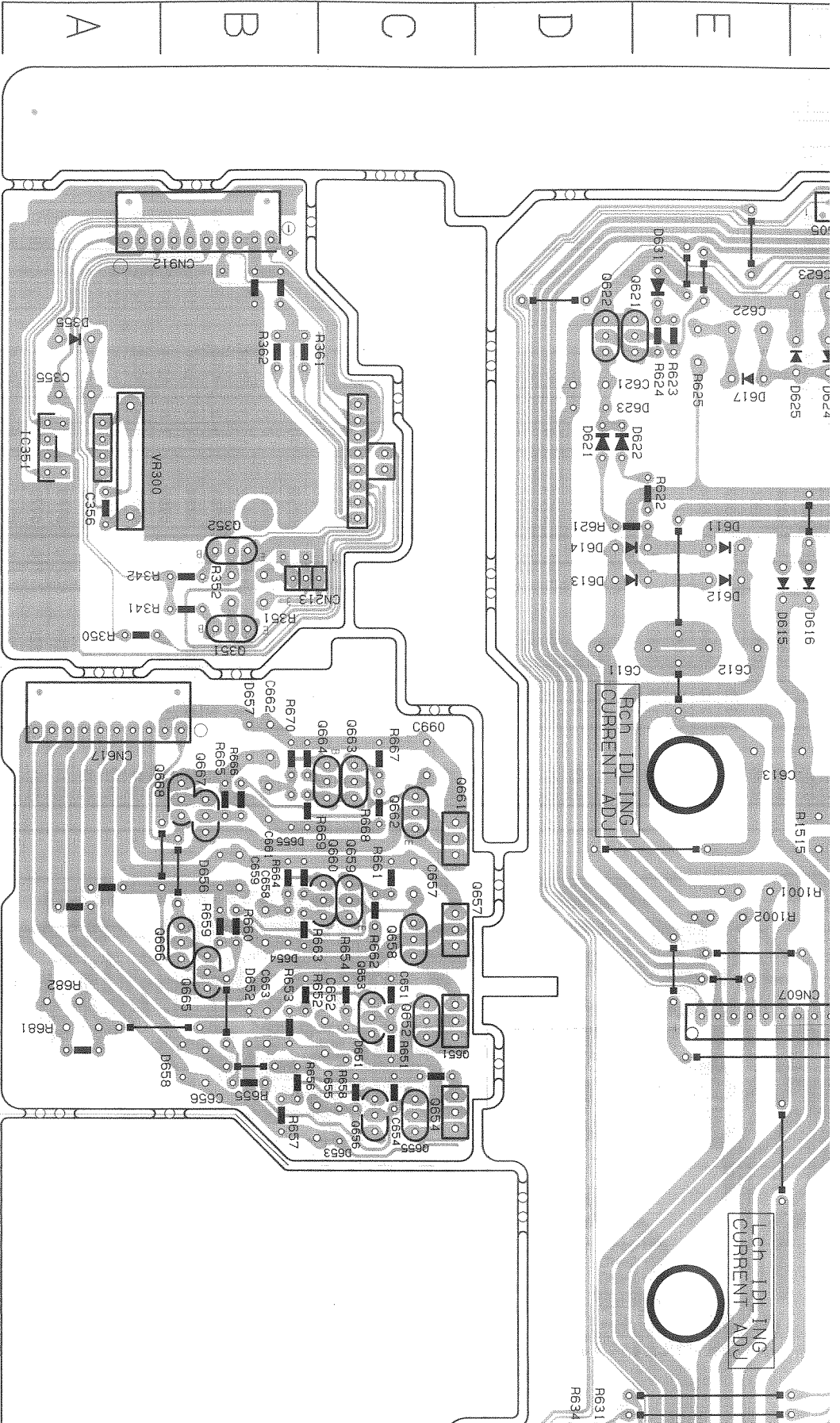

■ System Control and Power Supply P.C.B(ENB-241)

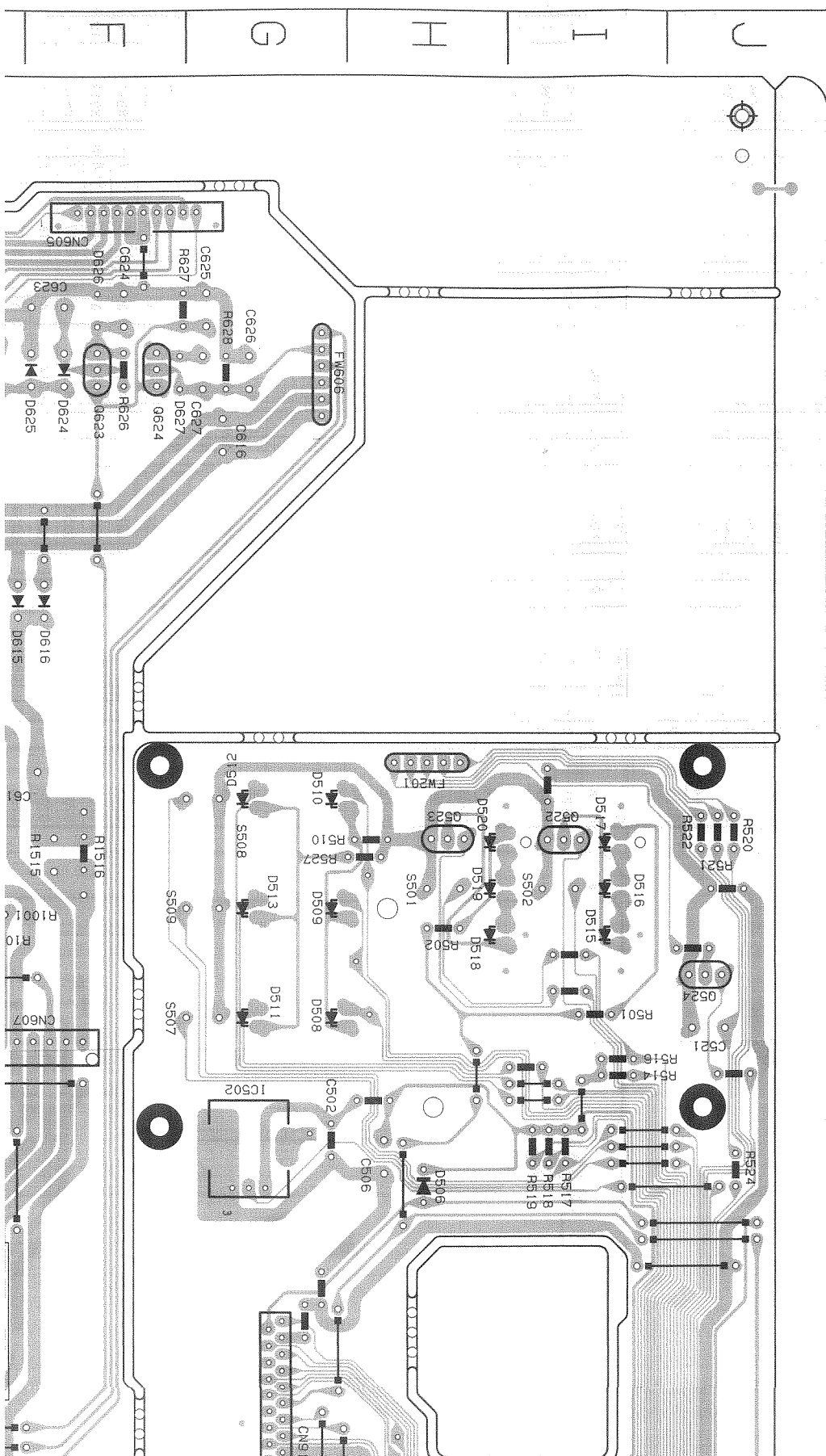

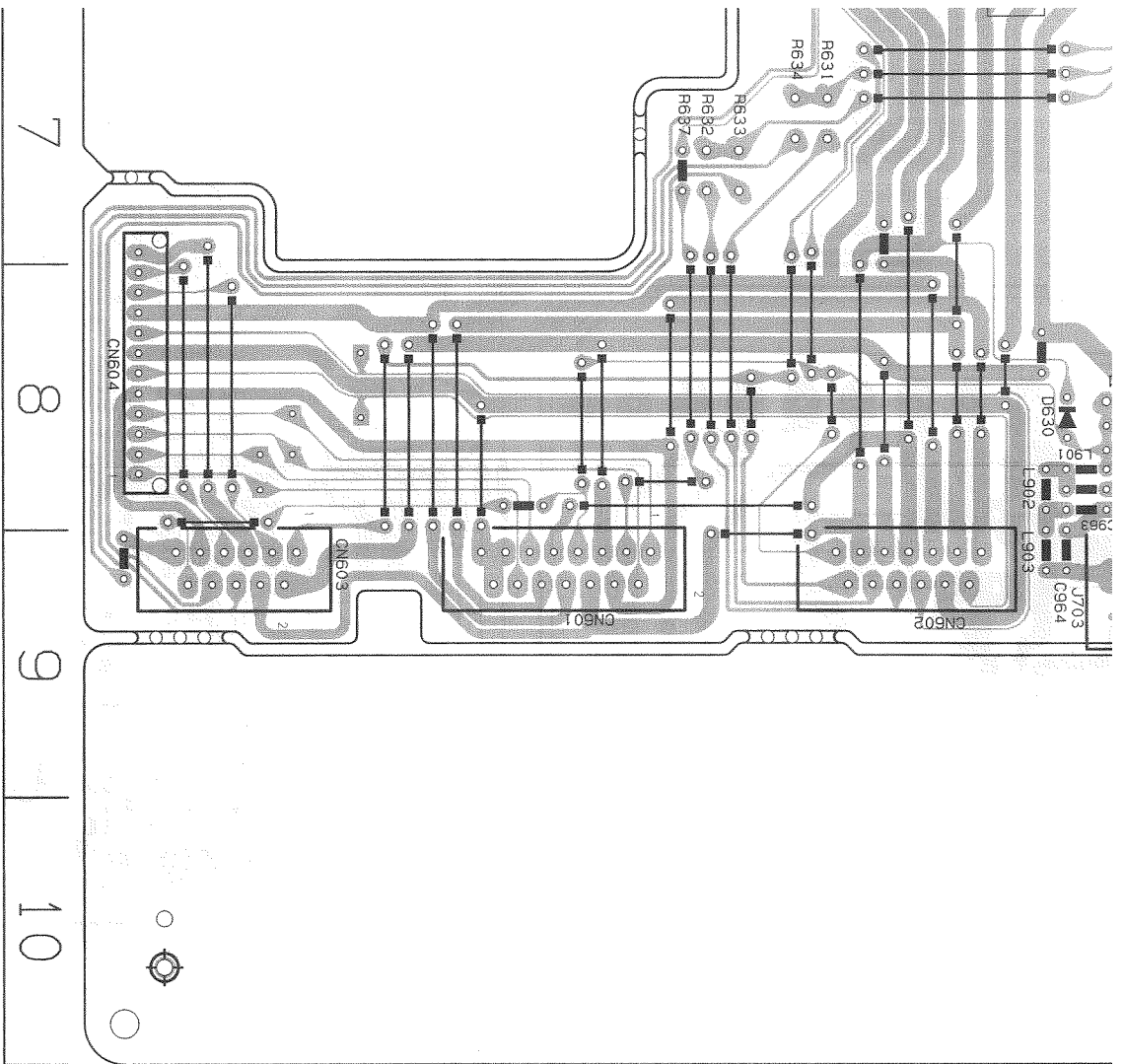

0623	2 F	D616	2 E	0666	4 B	R653	5 B
0624	1 F	D617	2 E	0667	4 B	R654	5 C
0625	1 G	D621	2 D	0668	4 B	R655	5 B
0626	2 G	D622	2 D	R1001	4 E	R656	5 B
0627	2 G	D623	2 D	R1002	4 E	R657	5 B
0628	8 F	D624	2 F	R1515	4 F	R658	5 C
0661	5 C	D625	2 F	R1516	4 F	R659	4 B
0662	5 C	D626	2 F	R307	8 H	R660	4 B
0663	5 B	D627	2 F	R308	8 H	R661	4 C
0664	5 C	D629	8 F	R309	8 G	R662	4 C
0665	5 B	D630	8 F	R310	8 H	R663	4 B
0666	5 B	D631	1 E	R311	8 H	R664	4 B
0667	4 C	D651	5 C	R312	8 G	R665	4 B
0668	4 B	D652	5 B	R313	8 G	R666	4 B
0669	4 B	D653	5 C	R314	8 G	R667	4 C
0660	4 C	D654	4 B	R341	3 B	R668	4 C
0661	4 B	D655	4 B	R342	3 B	R669	4 B
0662	4 B	D666	4 B	R350	3 A	R670	4 B
0951	9 G	D667	3 B	R351	3 B	R681	5 A
0952	10 G	D658	5 B	R352	3 B	R682	5 A
0961	8 F	FW201	4 H	R361	2 B	R999	7 H
0962	8 E	FW606	2 G	R362	2 B	S501	4 H
0963	8 E	IC351	2 A	R501	5 I	S502	4 I
0964	8 E	IC501	9 H	R502	4 H	S503	10 H
CN213	3 B	IC502	5 G	R508	9 J	S507	5 G
CN601	8 C	J703	8 F	R509	9 J	S508	4 G
CN602	8 E	J791	10 G	R510	4 H	S509	4 G
CN603	8 B	L901	8 E	R511	9 I	TW111	10 F
CN604	8 A	L902	8 E	R513	7 I	X501	9 I
CN605	1 G	L903	8 E	R514	5 I		
CN607	5 E	L904	8 F	R515	9 H		
CN615	7 J	L905	8 F	R516	5 I		
CN617	3 B	0351	3 B	R517	5 I		
CN911	7 G	0352	3 B	R518	5 I		
CN912	1 B	0503	9 I	R519	5 I		

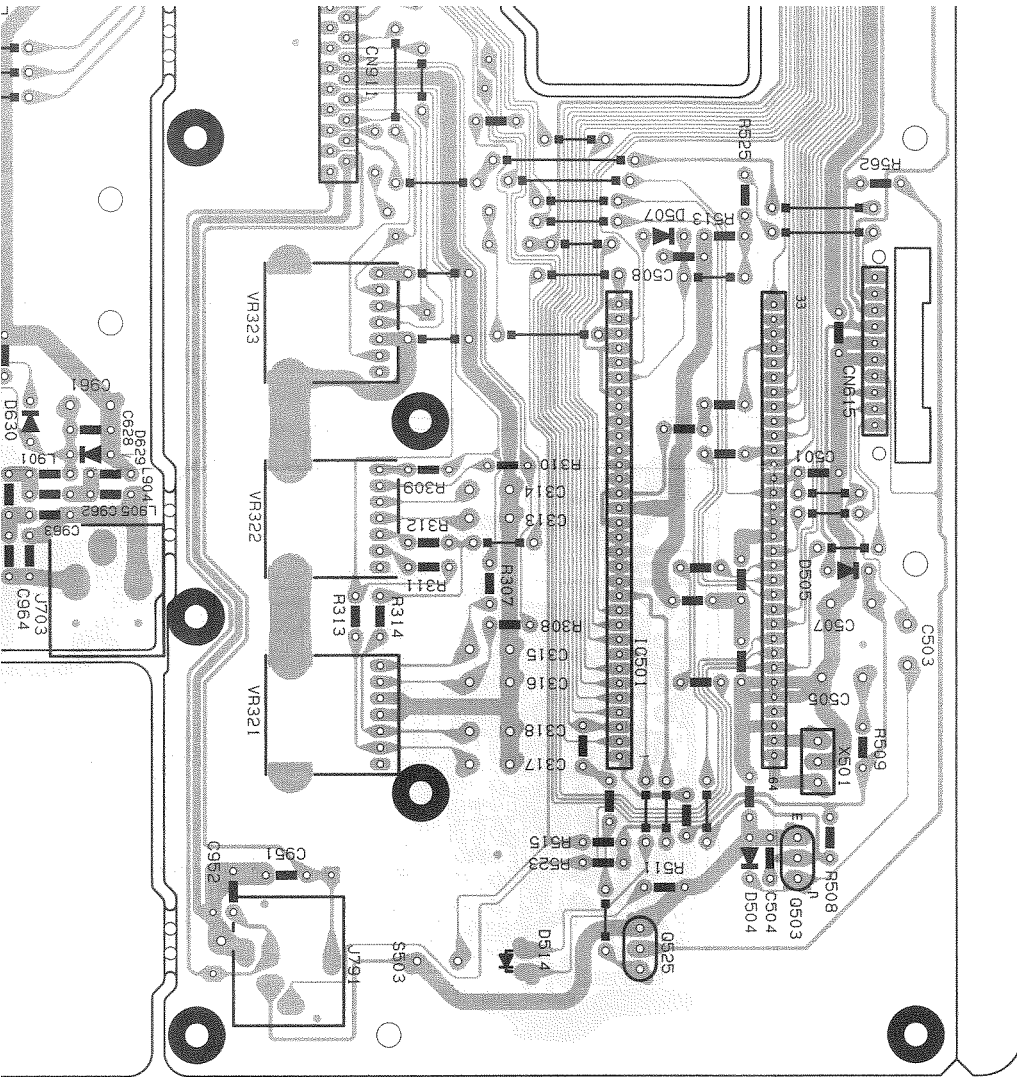

Location List (ENB-241)

Symbol	X	Y	Symbol	X	Y	Symbol	X	Y	Symbol	X	Y
C313	8	H	D355	2	A	0522	4	I	R520	4	J
C314	8	H	D504	9	I	0523	4	H	R521	4	J
C315	9	H	D505	8	J	0524	4	J	R522	4	J
C316	9	H	D506	5	H	0525	10	I	R523	9	H
C317	9	H	D507	7	I	0621	2	E	R524	5	J
C318	9	H	D508	5	H	0622	2	D	R525	7	I
C355	2	A	D509	4	H	0623	2	F	R527	4	H
C356	2	A	D510	4	H	0624	2	F	R562	7	J
C501	8	I	D511	5	G	0651	5	C	R621	3	D
C502	5	G	D512	4	G	0652	5	C	R622	2	E
C503	8	J	D513	4	G	0653	5	C	R623	2	E
C504	9	I	D514	10	H	0654	5	C	R624	2	E
C505	9	J	D515	4	I	0655	5	C	R625	2	E
C506	5	H	D516	4	I	0656	5	C	R626	2	F
C507	8	J	D517	4	I	0657	4	C	R627	1	F
C508	7	I	D518	4	H	0658	4	C	R628	2	G
C521	5	J	D519	4	H	0659	4	C	R631	7	D
C611	3	E	D520	4	H	0660	4	C	R632	7	D
C612	3	E	D611	3	E	0661	4	C	R633	7	D
C613	4	F	D612	3	E	0662	4	C	R634	7	D
C616	2	G	D613	3	D	0663	4	C	R637	7	D
C621	2	D	D614	3	D	0664	4	C	R651	5	C
C622	2	E	D615	3	E	0665	4	B	R652	5	B
C623	2	F	D616	3	F	0666	4	B	R653	5	B
C624	1	F	D617	2	E	0667	4	B	R654	5	C
C625	1	G	D621	2	D	0668	4	B	R655	5	B

P2-13-a

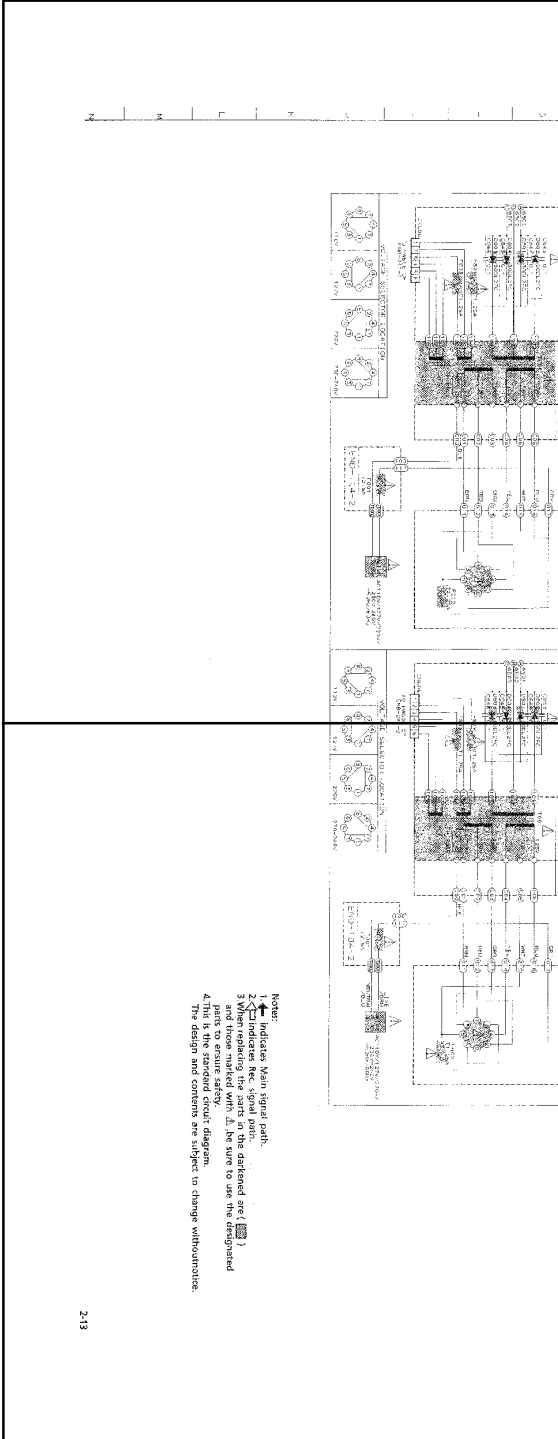

P2-13-b

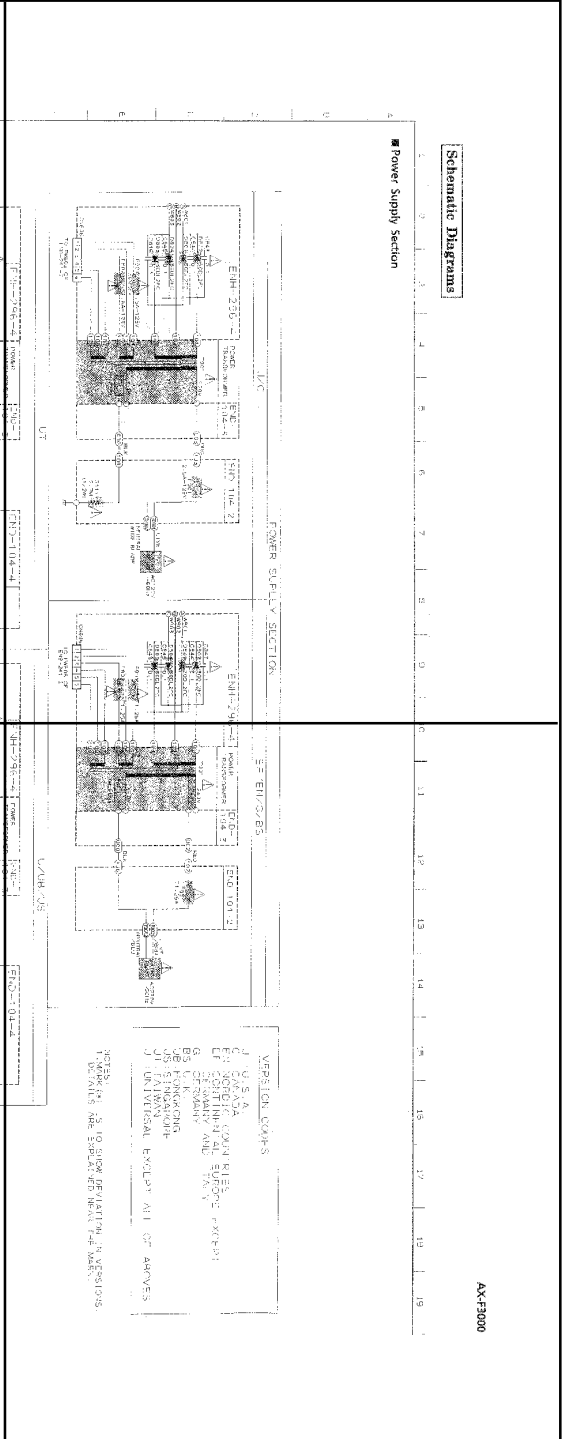

P2-13-c





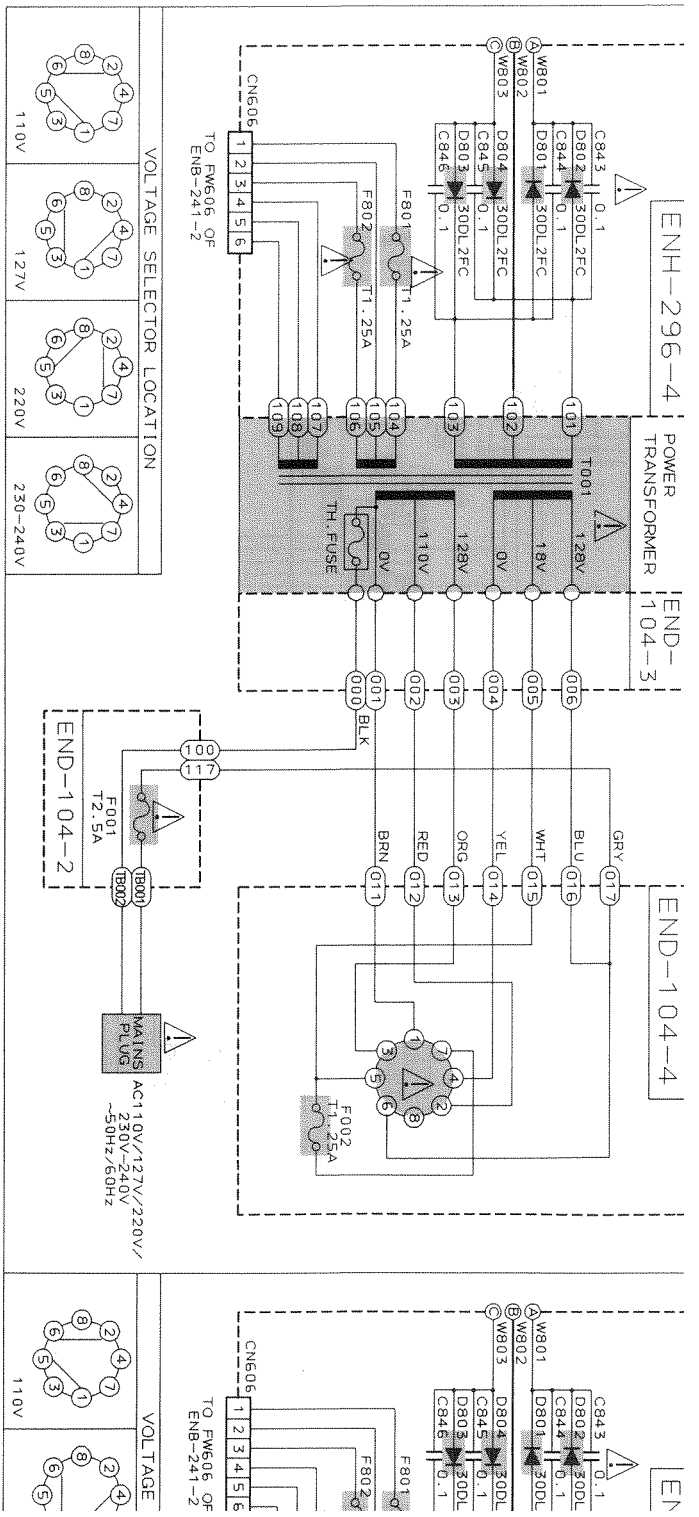

P2-13-d

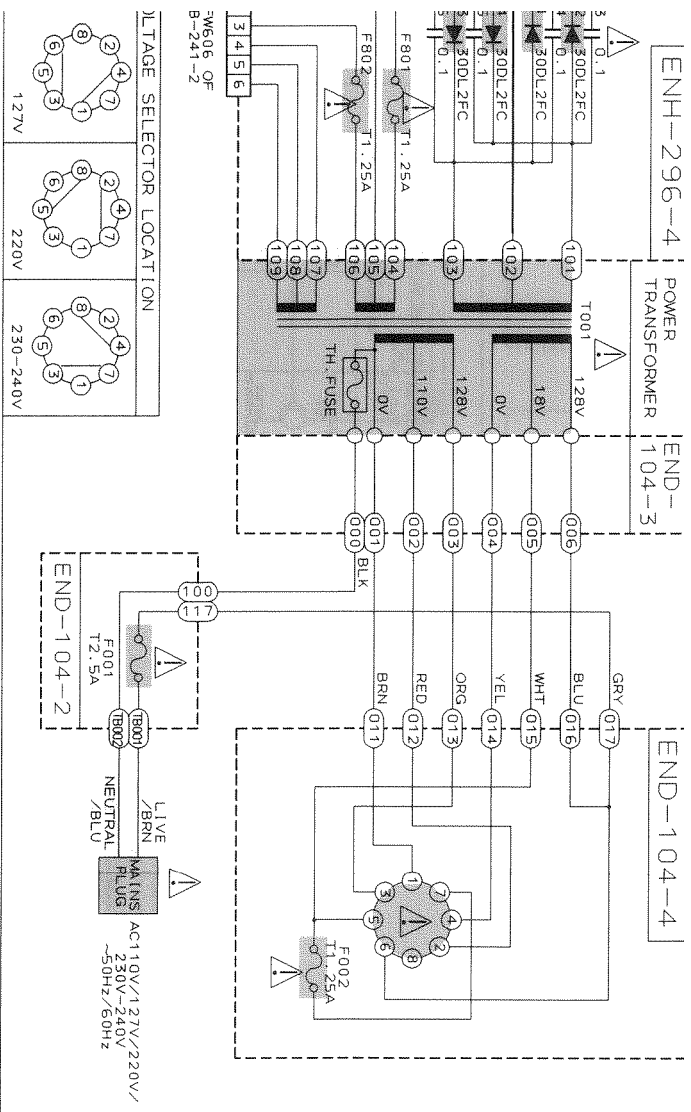





Notes:

1.  indicates Main signal path.
2.  indicates Rec. signal path.
3. When replacing the parts in the darkened are () and those marked with  , be sure to use the designated parts to ensure safety.
4. This is the standard circuit diagram. The design and contents are subject to change without notice.

10 | 11 | 12 | 13 | 14 | 15 | 16 | 17 | 18 | 19

EF/EN/G/BS

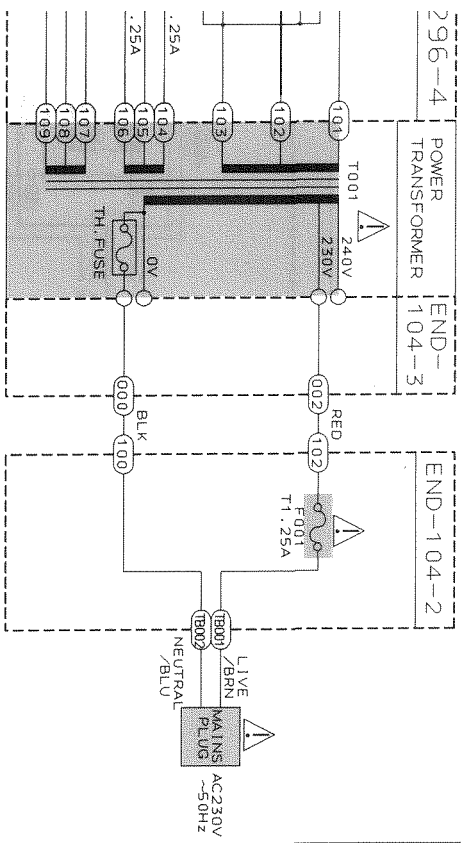

U/UB/US

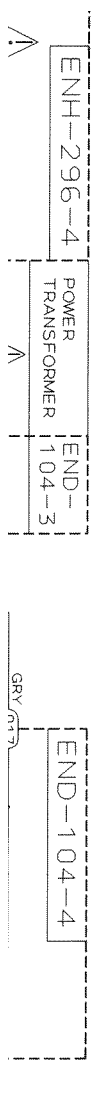

VERSION CODES

- J : U.S.A.
- C : CANADA
- EN : NORDIC COUNTRIES
- EF : CONTINENTAL EUROPE EXCEPT GERMANY AND ITALY
- G : GERMANY
- BS : U.K.
- UB : HONGKONG
- US : SINGAPORE
- UT : TAIWAN
- U : UNIVERSAL EXCEPT ALL OF ABOVE

NOTES:
 1. MARK (*) IS TO SHOW DEVIATION IN VERSIONS.
 DETAILS ARE EXPLAINED NEAR THE MARK.

ENH-296-4

POWER TRANSFORMER

END-104-3

END-104-4



GRY INT

P2-14-a

P2-14-b

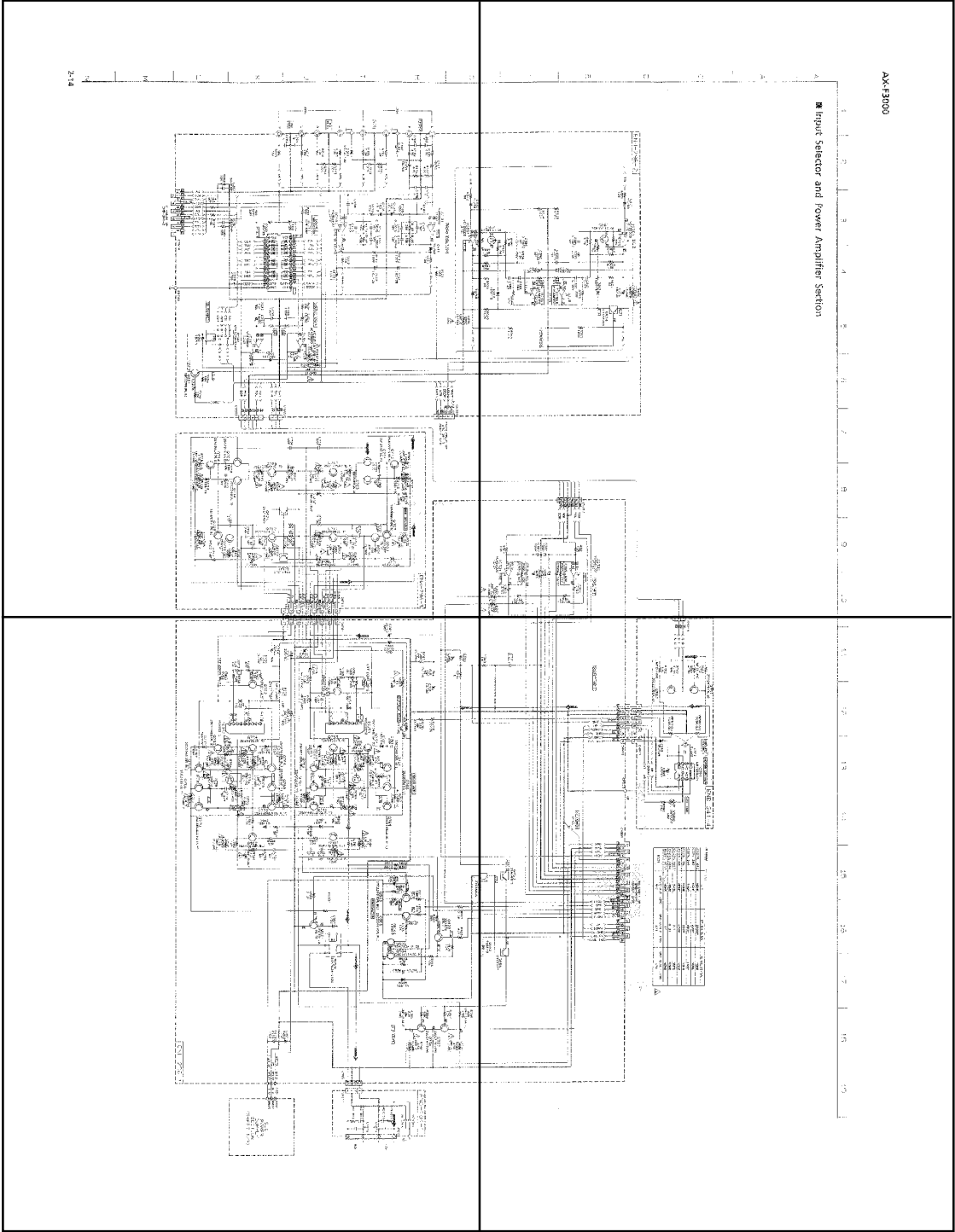

P2-14-c

P2-14-d

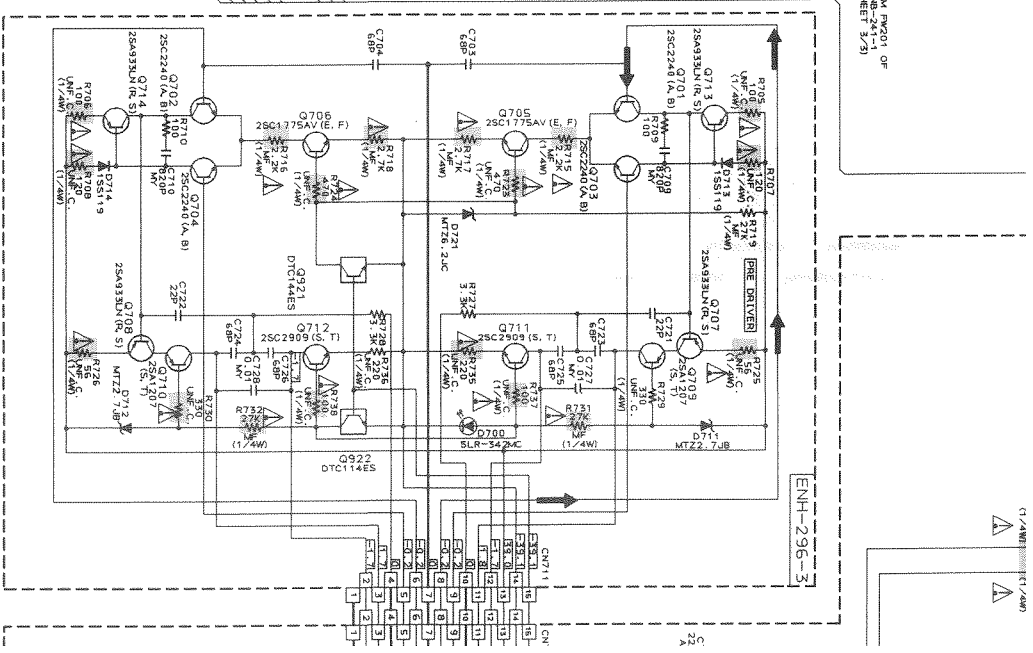
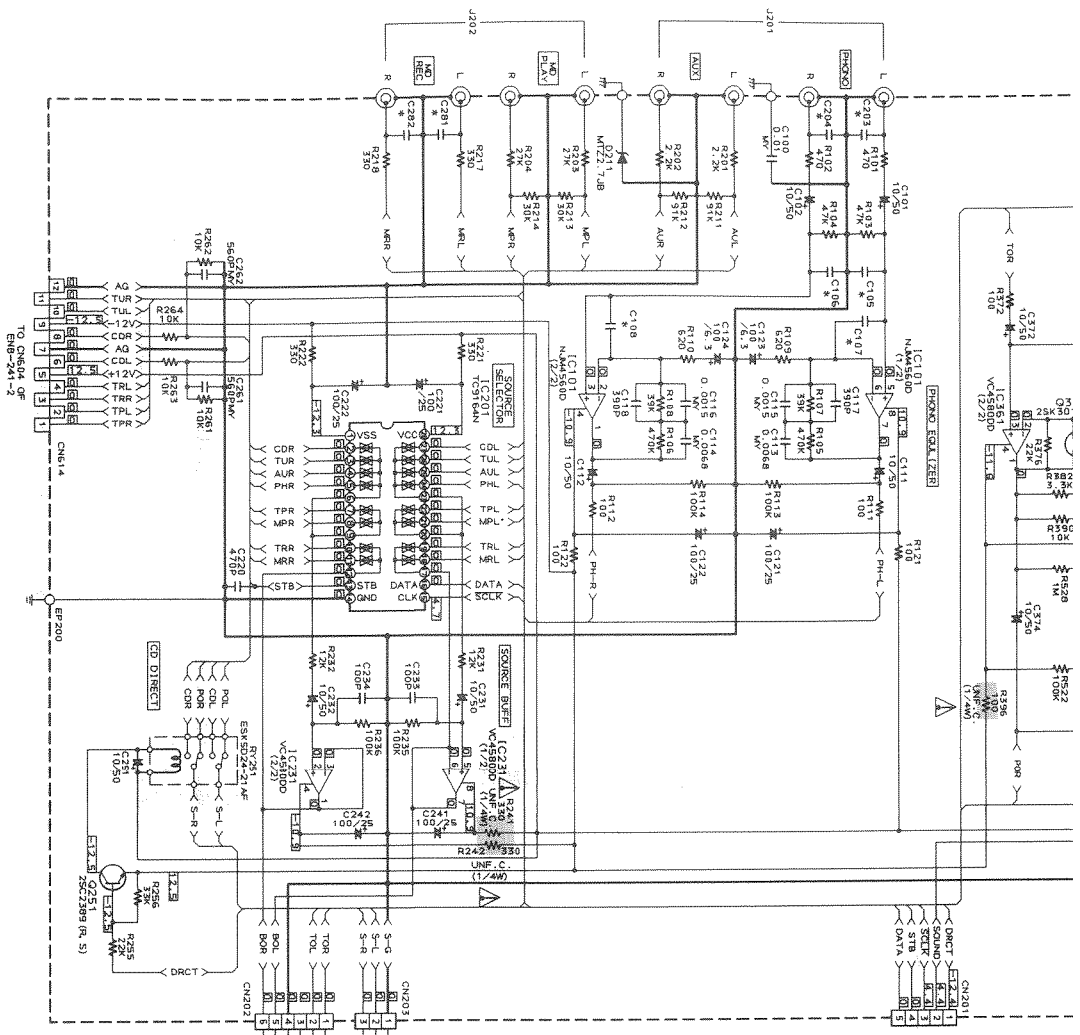

1 2 3 4 5 6 7 8 9 10

Input Selector and Power Amplifier Section

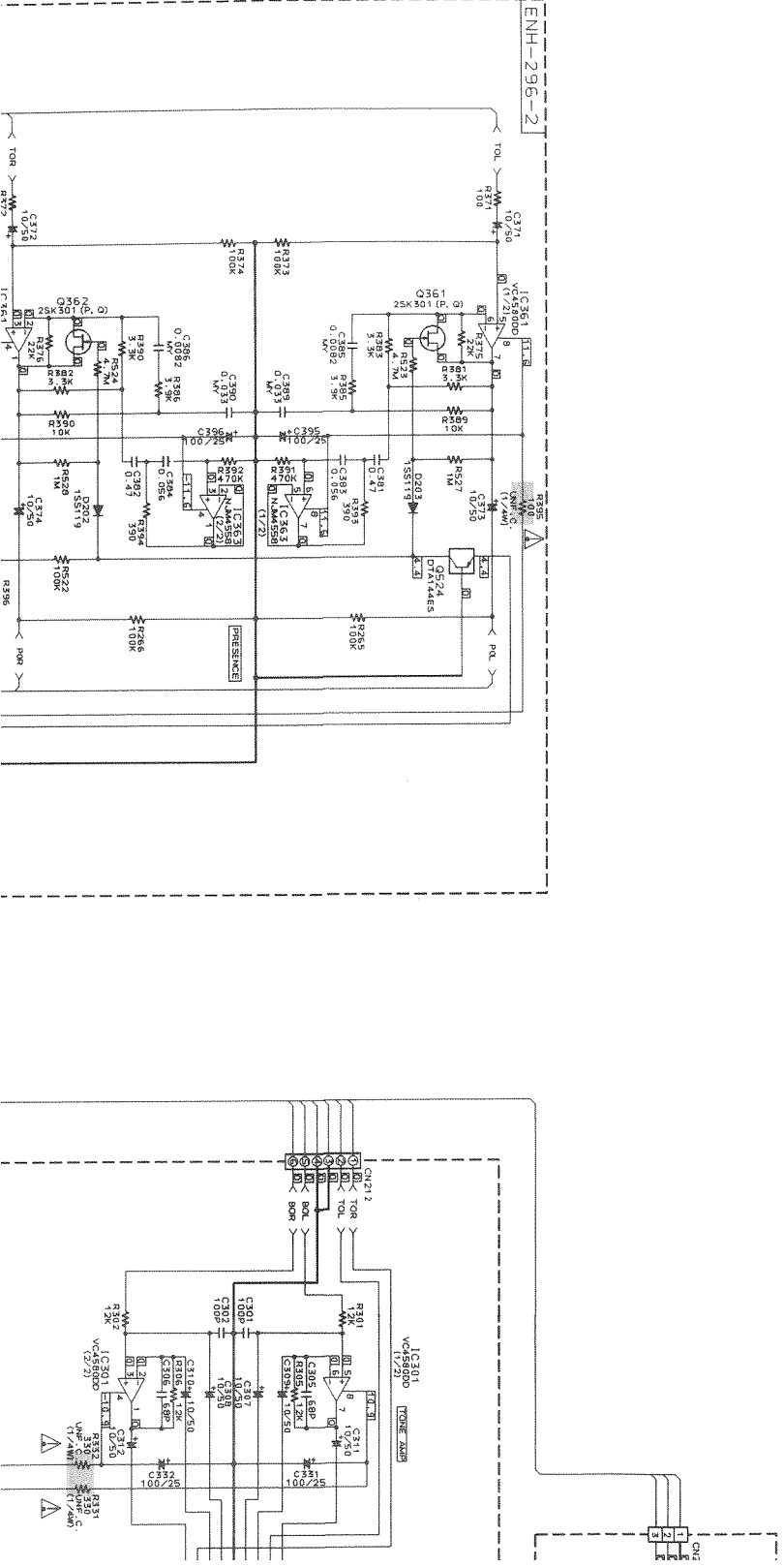

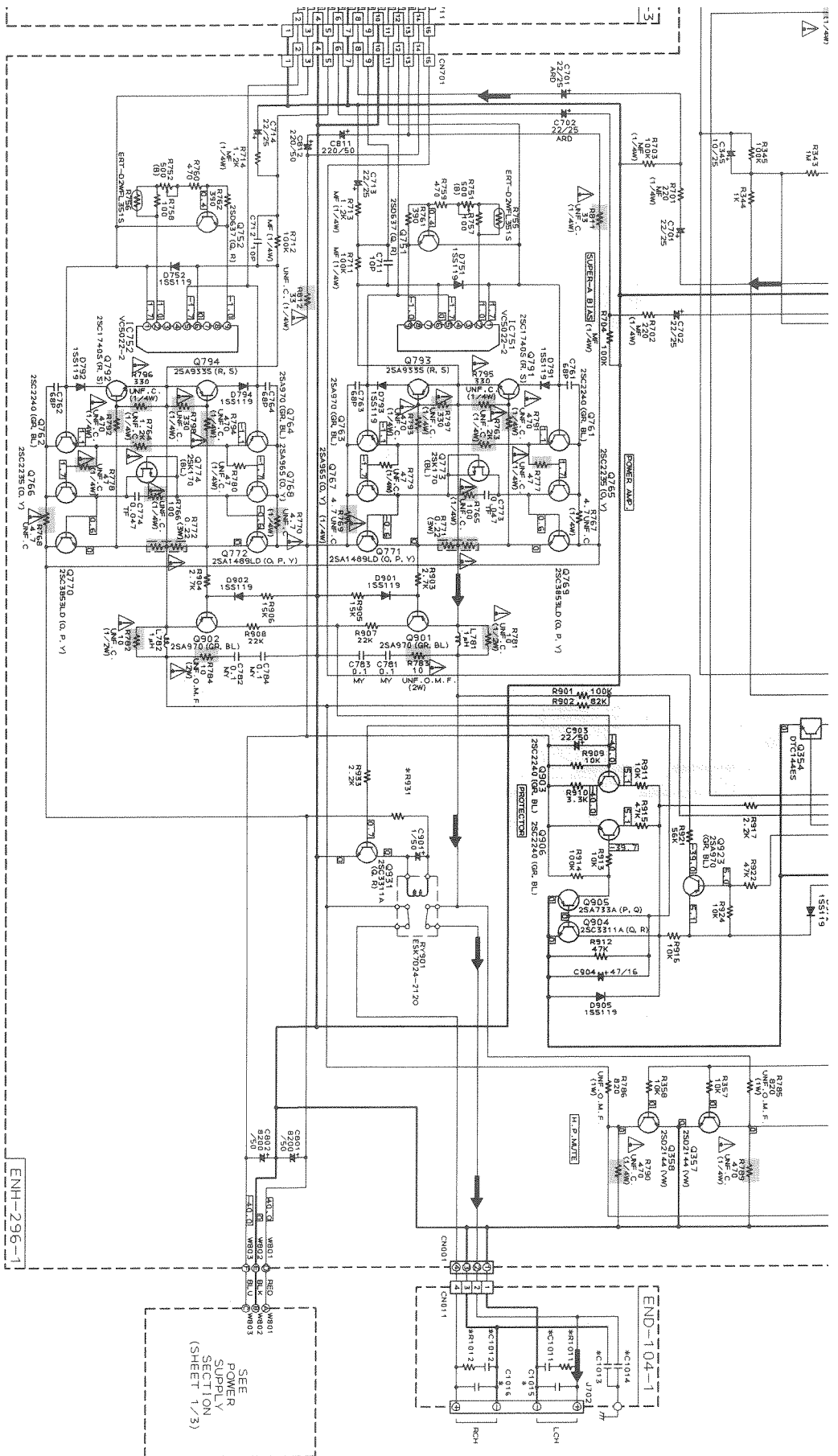

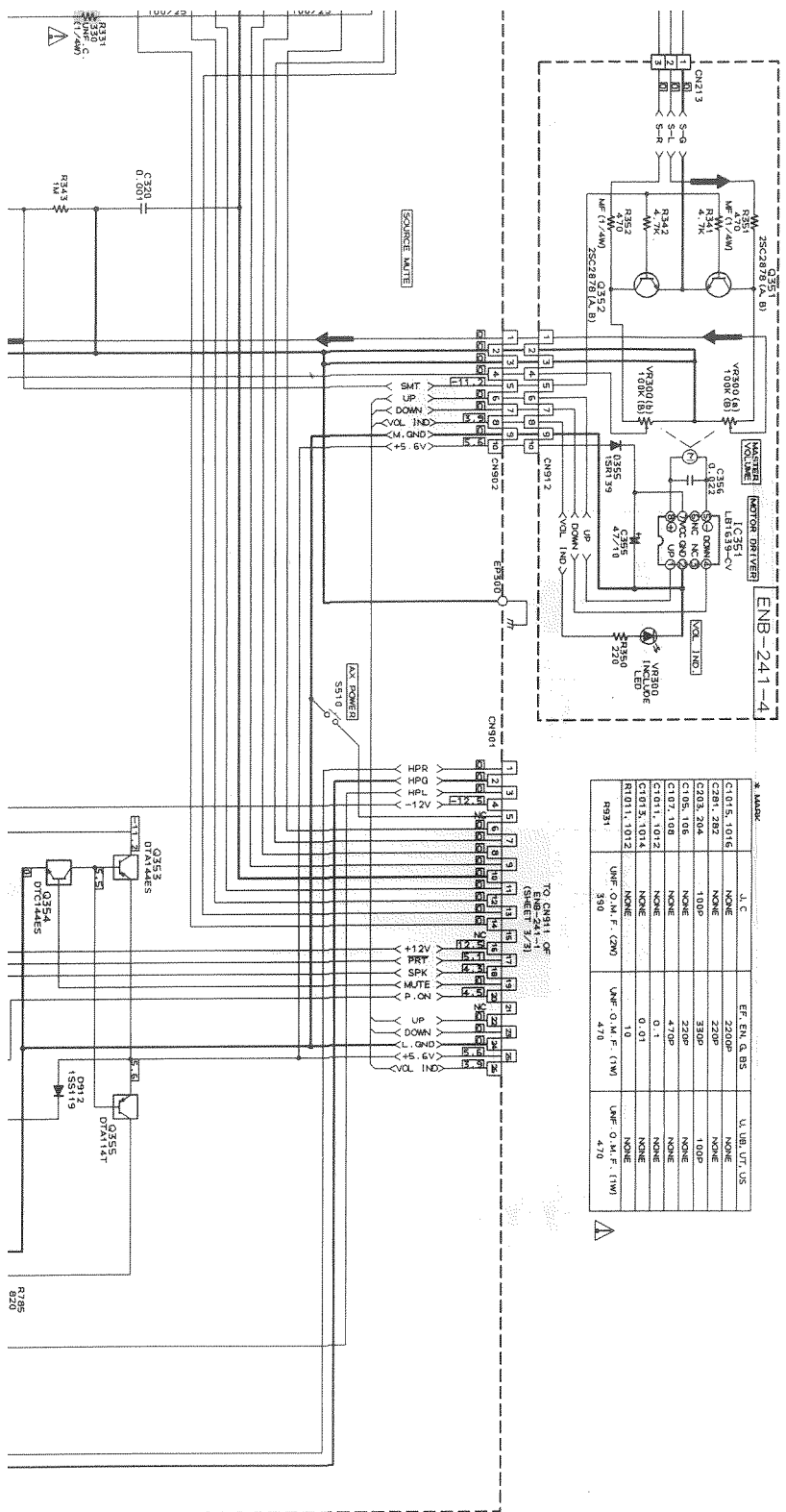

P2-15-a

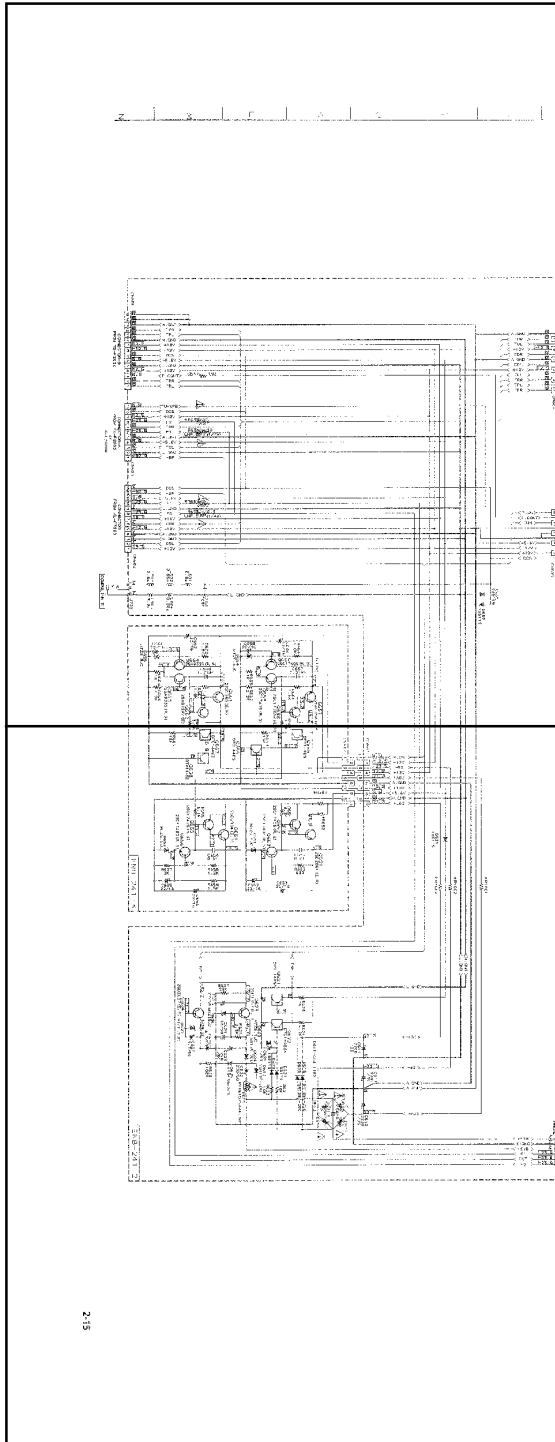

2-13

P2-15-b

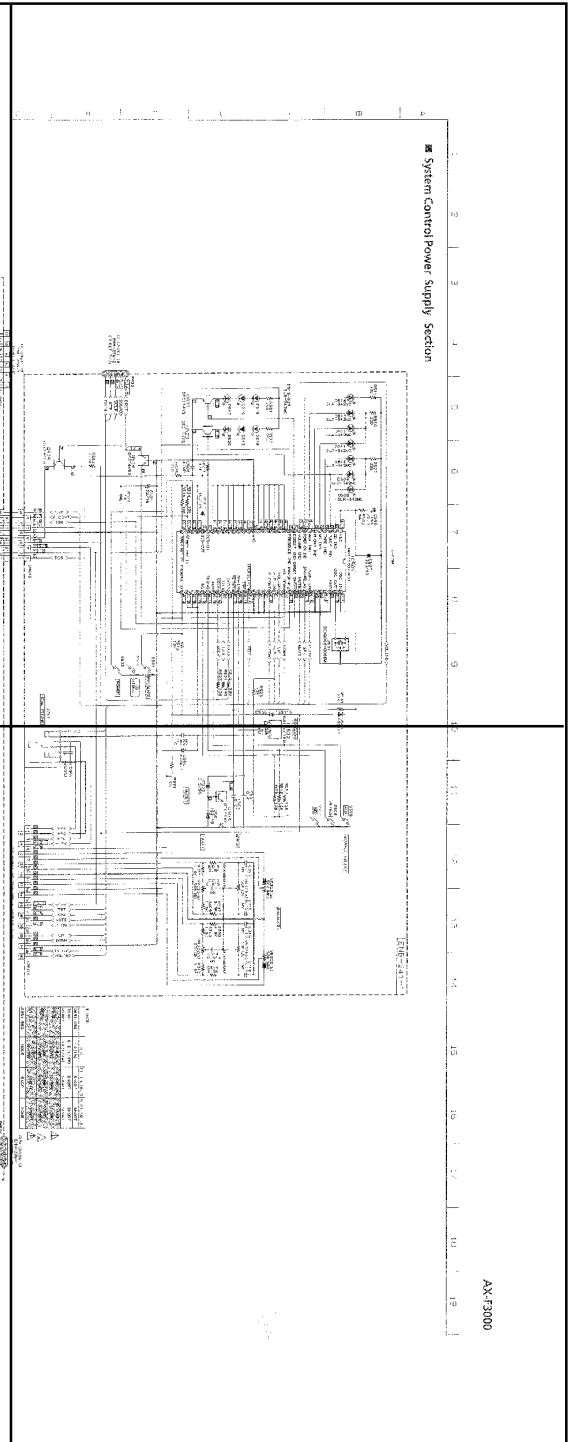

AX-F3000

P2-15-c

P2-15-d

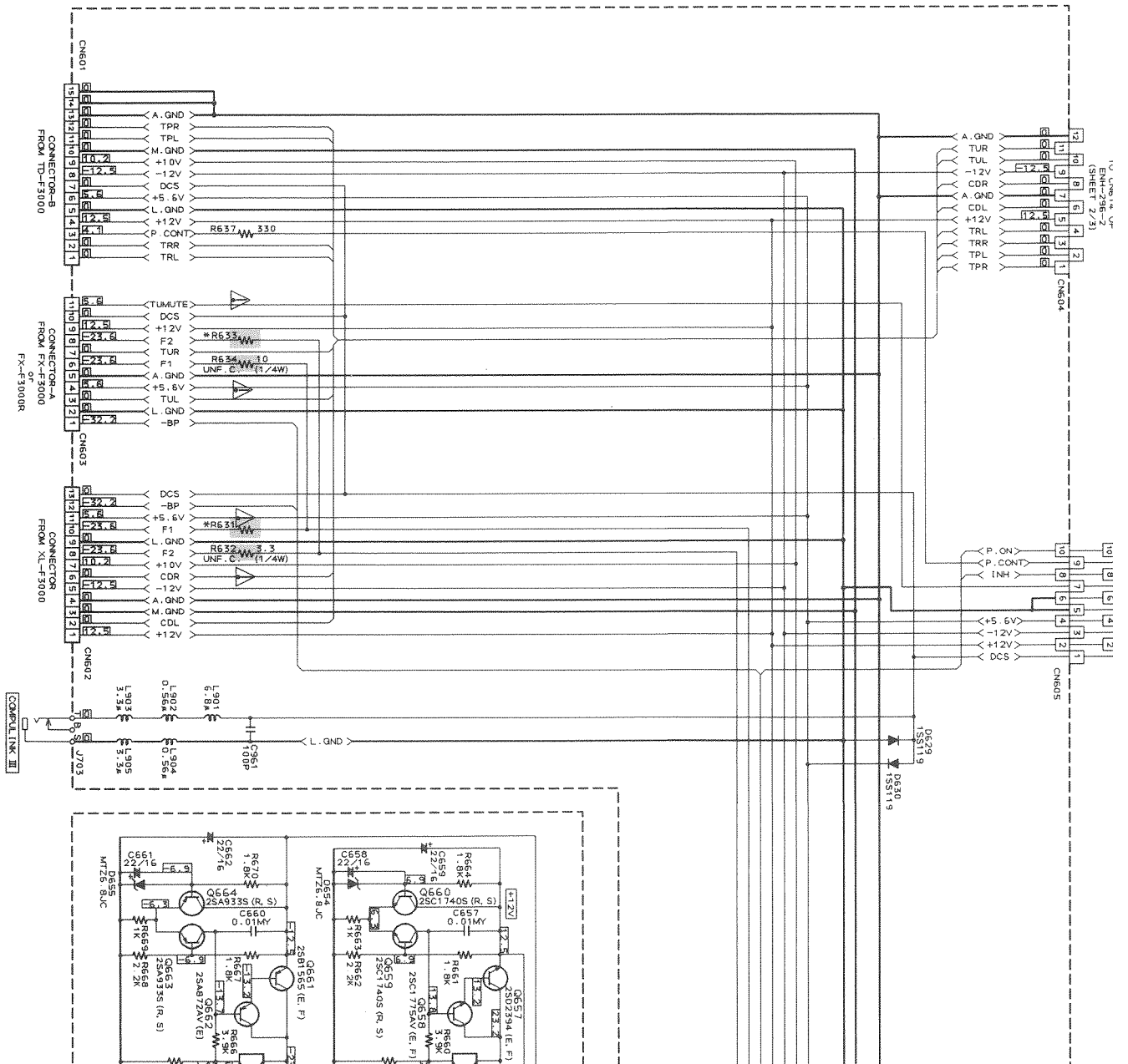

System Control Power Supply Section

1 | 2 | 3 | 4 | 5 | 6 | 7 | 8 | 9 | 10

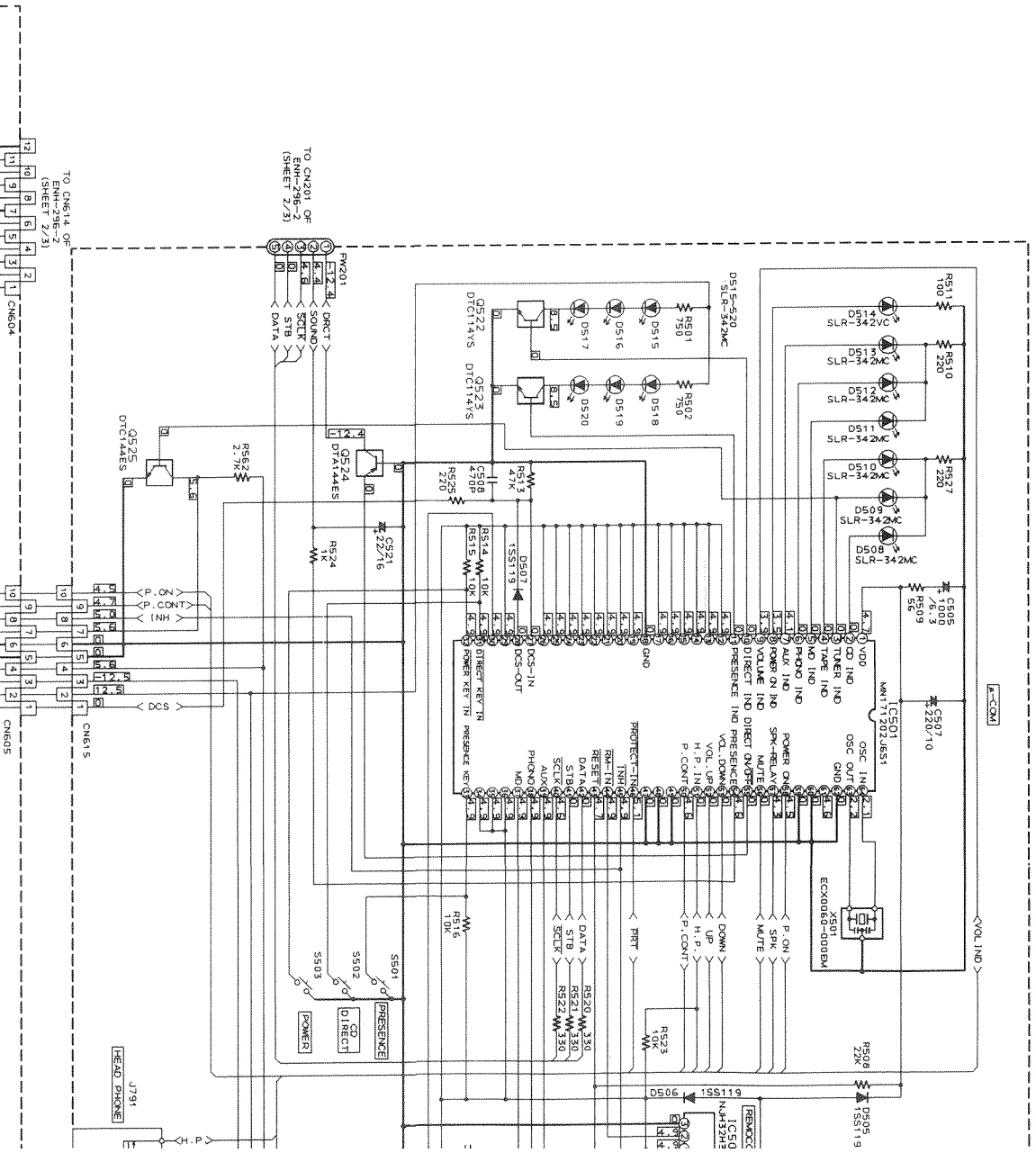

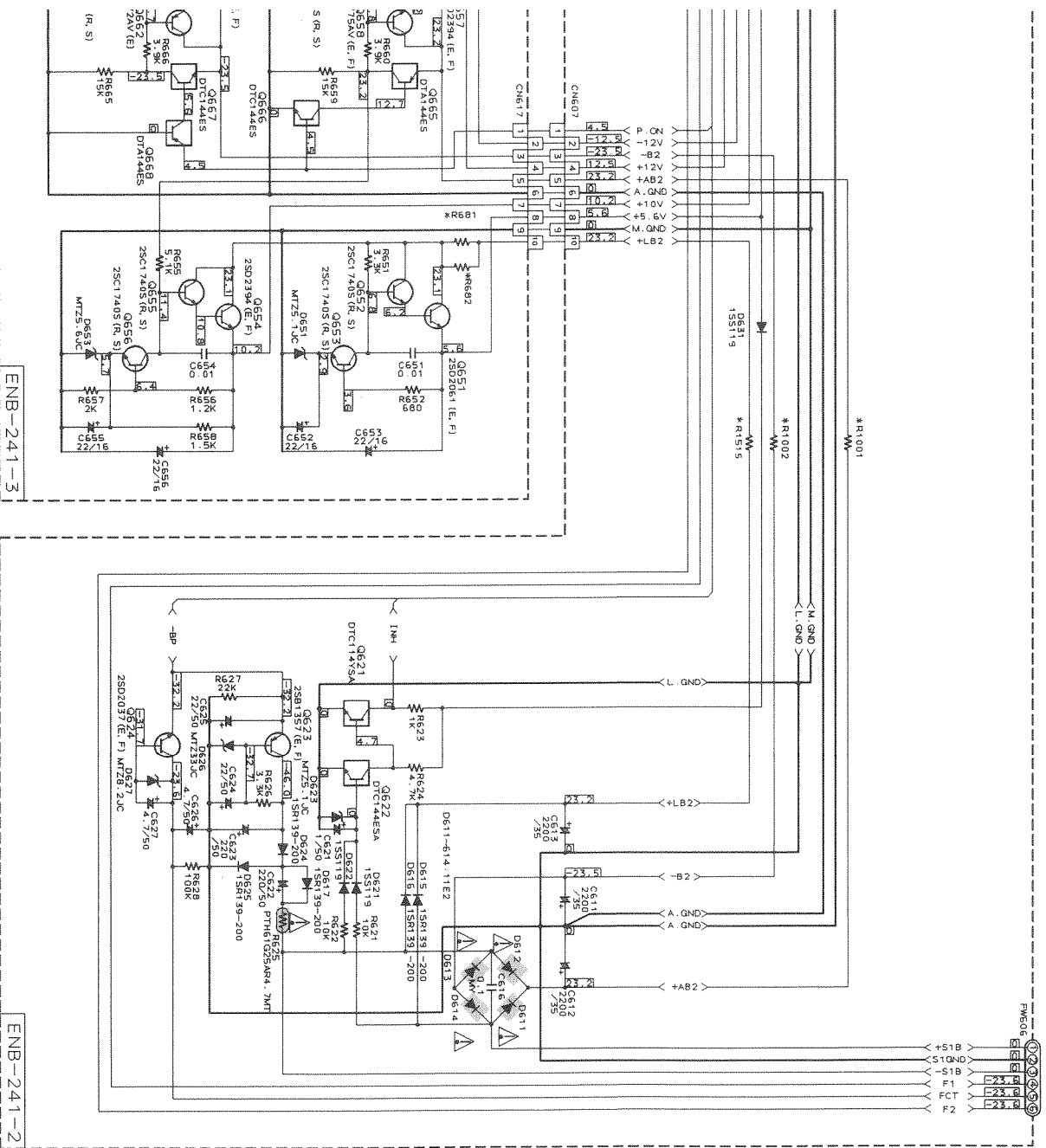

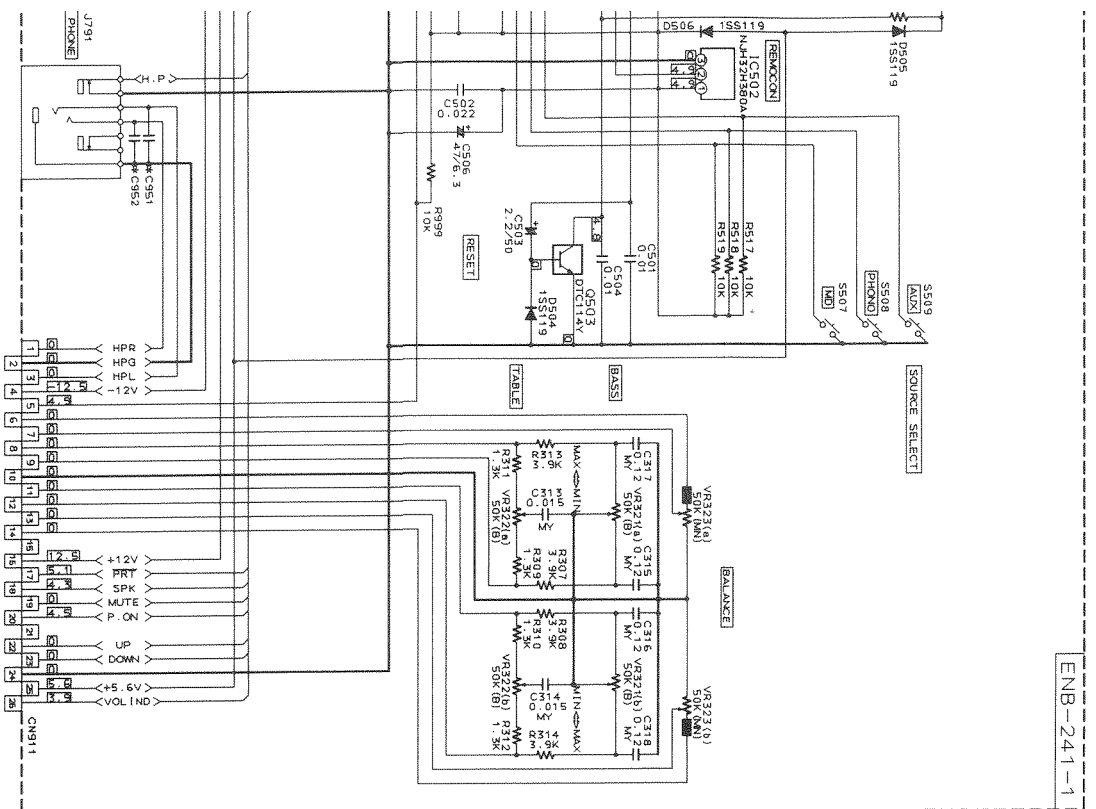

* MARK

R951, 952	J.C	EF, EN, BS, G, U, UT, UB, US	SHORT	SHORT
R6B1, 6B2	10 (1W)		SHORT	SHORT
R1001	6.8 (1/4W)		SHORT	SHORT
R1002	10 (1/4W)		SHORT	SHORT
R6S1	2.7 (1/4W)		SHORT	SHORT
R6S3	8.2 (1/4W)		SHORT	SHORT
R1S1S	1.0 (1/4W)		SHORT	SHORT
R951, 952	NONE		SHORT	NONE

FROM CN606 OF ENH-296-4 (SHEET 1/3)

FROM ENH-296-1 (SHEET 2/3)

XL-F3000

Contents

<i>Description of Major ICs</i>	3-2
<i>Internal Connection of Display</i>	3-8
<i>Disassembly Procedures</i>	3-9
<i>Flow of Functional Operation Until TOC is Read</i>	3-12
<i>Self - diagnosis for pickup</i>	3-14
<i>Block Diagram</i>	3-16
<i>Printed Circuit Boards</i>	3-17
<i>Schematic Diagrams</i>	3-18

■ MN171602JJX1 (IC901) : CD SYSTEM CONTROLLER

1. Terminal Layout

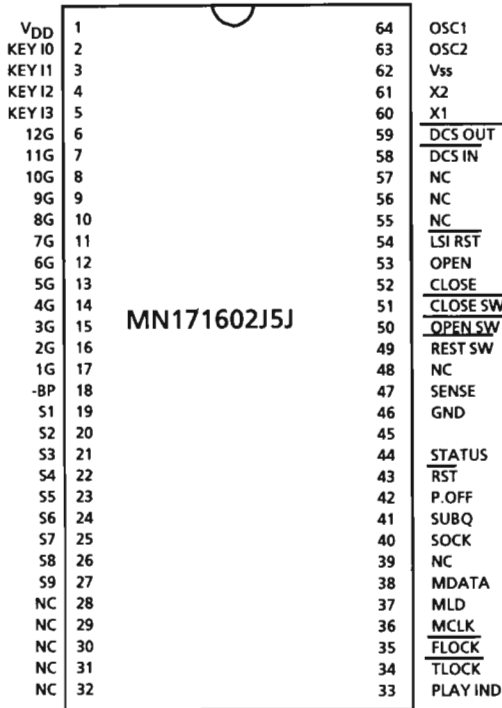

2. Key Matrix

	KEY I 0	KEY I 1	KEY I 2	KEY I 3
G4	■/CLEAR (S904)	▶/ (908)	REPEAT (S912)	--
G6	--	▲ (S906)	--	⏮ (S914)
G7	--	PROGRAM (S905)	--	⏭ (S913)

Pin Functions

Pin NO.	Symbol	I/O	Function	Pin NO.	Symbol	I/O	Function
1	VDD	--	+ 5V	33	PLAY IND	O	"PLAY" indicator control signa
2	KEY I0	I	Key input	34	TLOCK	I	Tracking Lock with "L"
3	KEY I1	I	Key input	35	FLOCK	I	Focus Lock with "L"
4	KEY I2	I	Key input	36	MCLK	O	Command Clock Signal
5	KEY I3	I	Key input	37	MLD	O	Command Load Signal
6	12G	O	FL Grid control signal	38	MDATA	O	Command Data Signal
7	11G	O	FL Grid control signal	39	NC	-	Not used
8	10G	O	FL Grid control signal	40	SOCK	O	External clock for Sub Code Q register
9	9G	O	FL Grid control signal	41	SUBQ	I	Sub code Q code input
10	8G	O	FL Grid control signal	42	P.OFF	O	Power off signal output (L:ON,H:OFF)
11	7G	O	FL Grid control signal(Key output)	43	RST	I	Reset signal input
12	6G	O	FL Grid control signal(Key output)	44	STATUS	I	Status signal input
13	5G	O	FL Grid control signal	45		-	GND
14	4G	O	FL Grid control signal(Key output)	46	GND	-	GND
15	3G	O	FL Grid control signal	47	SENSE	I	Sense signal input
16	2G	O	FL Grid control signal	48	NC	-	Not used
17	1G	O	FL Grid control signal	49	RESET SW	I	RESET SW active: low
18	-BP	I	FL Power	50	OPEN SW	I	OPEN SW active: low
19	S1	O	FL anode control signal	51	CLOSE SW	I	CLOSE SW active: low
20	S2	O	FL anode control signal	52	CLOSE	O	CLOSE signal output
21	S3	O	FL anode control signal	53	OPEN	O	OPEN signal output
22	S4	O	FL anode control signal	54	LSIRST	O	CD reset signal output (L:RESET)
23	S5	O	FL anode control signal	55	NC	-	Not used
24	S6	O	FL anode control signal	56	NC	-	Not used
25	S7	O	FL anode control signal	57	NC	-	Not used
26	S8	O	FL anode control signal	58	DCS IN	I	Compulink signal input
27	S9	O	FL anode control signal	59	DCS OUT	O	Compulink signal output
28	NC	-	Not used	60	X1	-	Connected to Ground
29	NC	-	Not used	61	X2	-	Not connection
30	NC	-	Not used	62	Vss	-	GND
31	NC	-	Not used	63	OSC2	O	Clock oscillation output
32	NC	-	Not used	64	OSC1	I	Clock oscillation input

■ AN8806SB (IC501) : RF & SERVO AMP

1. Terminal Layout

PD	1	36 PDAC
LD	2	35 PDBD
LDON	3	34 PDE
LDP	4	33 PDF
VCC	5	32 PDER
RF-	6	31 PDFR
RF OUT	7	30 TBAL
RF IN	8	29 FBAL
C.AGC	9	28 FE-
ARF	10	27 FE OUT
C.ENV	11	26 TE-
C.EA	12	25 TE OUT
CS BDO	13	24 CROSS
BDO	14	23 TE BPF
CS BRT	15	22 VDET
OFTR	16	21 LD OFF
NRFDET	17	20 VREF
GND	18	19 ENV

2. Block Diagram

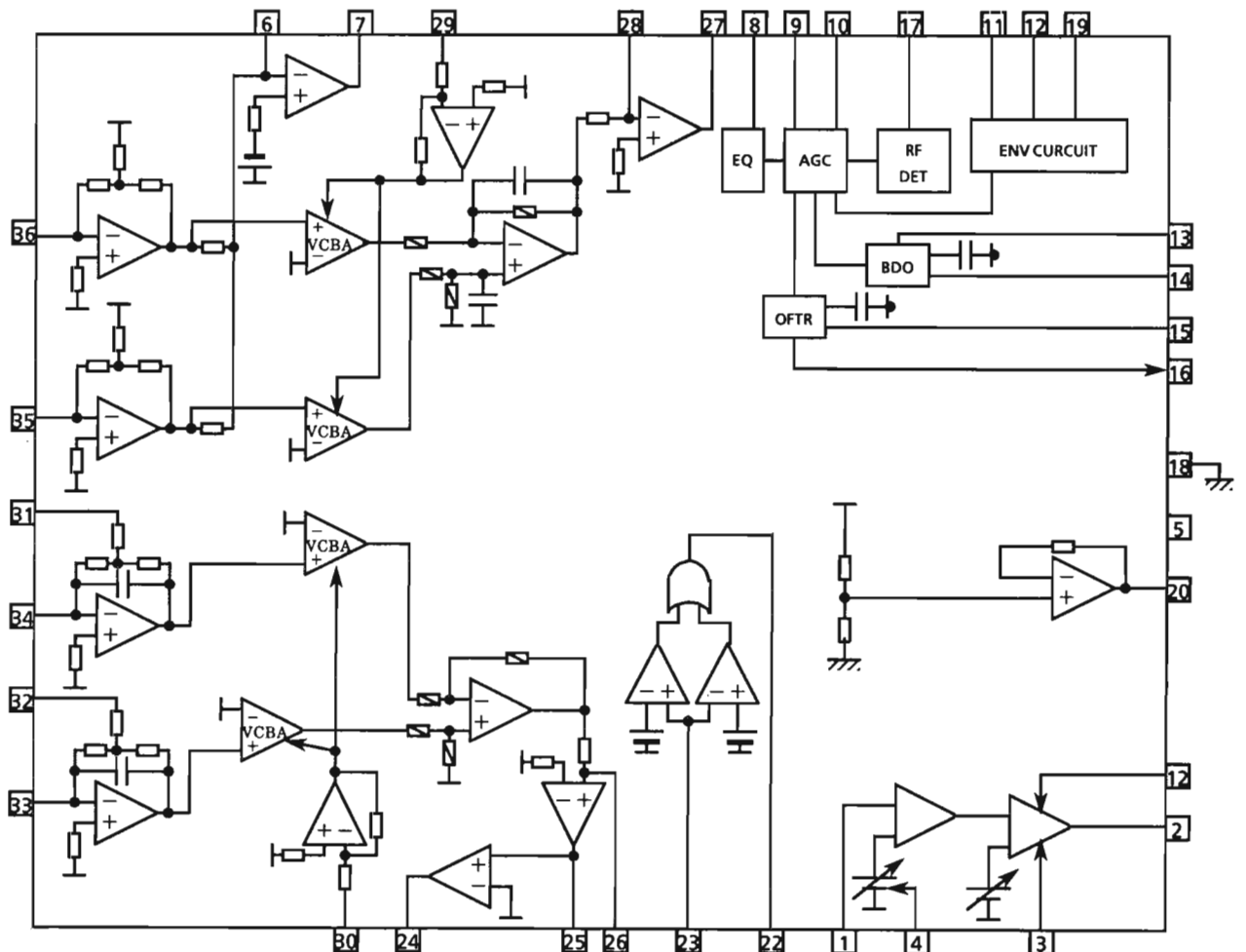

■ MN662720RB (IC401) : DIGITAL SERVO & DIGITAL SIGNAL PROCESSOR

1. Terminal Layout

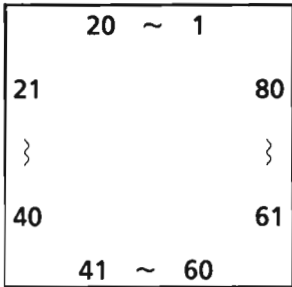

2. Block Diagram

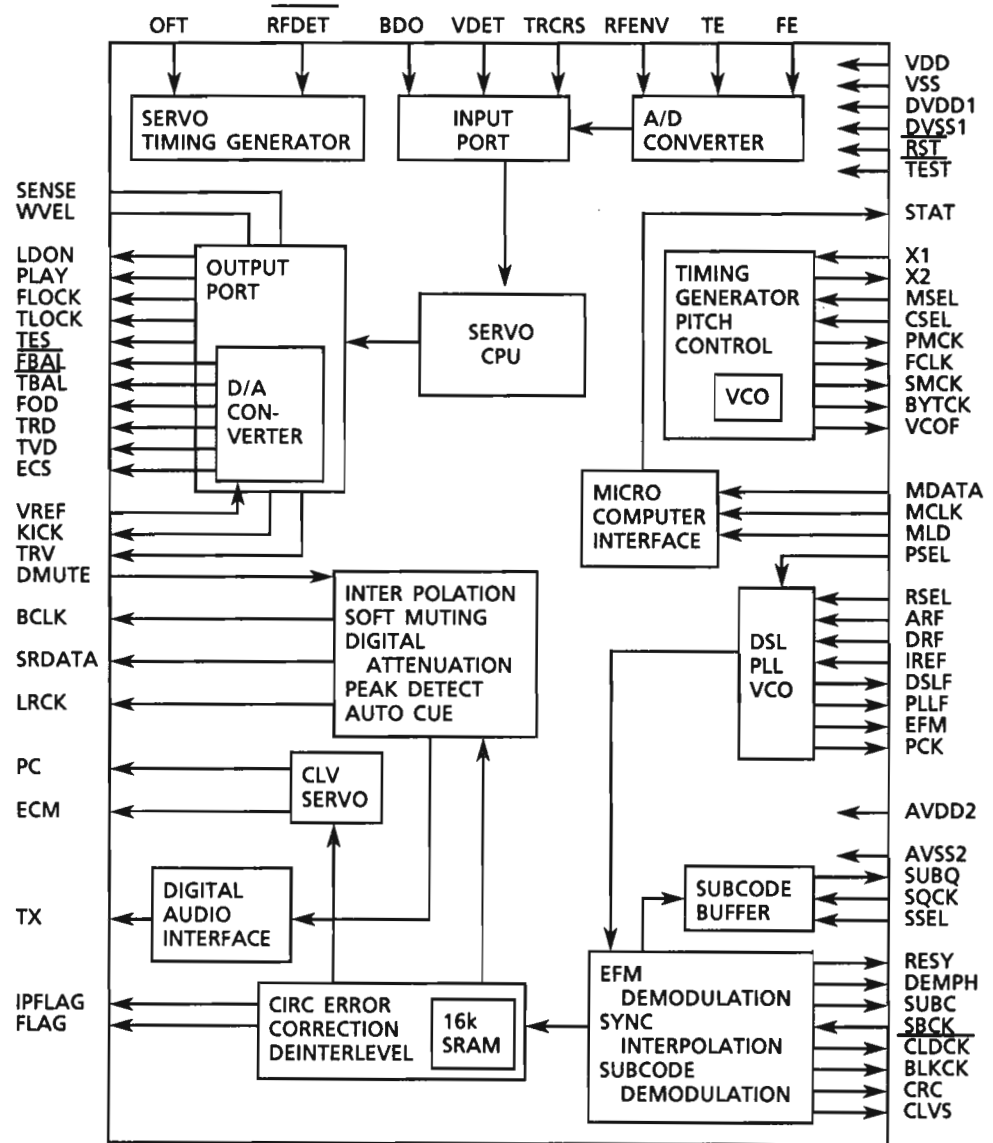

3. Description

Pin No.	symbol	I/O	Description	Pin No.	symbol	I/O	Description
1	BCLK	O	Bit clock output pin for SRDATA	41	TES	—	Not used
2	LRCK	O	L/R distinction signal output	42	PLAY	—	"
3	SRDATA	O	Serial data output	43	WVEL	—	"
4	DVDD1	—	Power supply(Digital)	44	ARF	I	RF signal input
5	DVSS1	—	Connected to GND(Digital)	45	IREF	I	Reference current input pin
6	TX	O	Digital audio interface signal	46	DRF	I	Bias pin for DSL
7	MCLK	I	μ-com command clock signal input (Data is latched at signal's rising point)	47	DSLIF	I/O	Loop filter pin for DSL
8	MDATA	I	μ-com command data input	48	PLLF	I/O	Loop filter pin for PLL
9	MLD	I	μ-com command load signal input	49	VCOF	—	Not used
10	SENSE	O	Sense signal output (OFT,FESL,NACEND,NAJEND,POSAD,SFG)	50	AVDD2	—	Power supply (Analog)
11	FLOCK	O	Lock signal for Focus L : pull	51	AVSS2	—	Connected to GND(Analog)
12	TLOCK	O	Lock signal for Tracking L : pull	52	EFM	—	Not used
13	BLKCK	O	Subcode · block · clock signal output	53	PCK	—	"
14	SQCK	I	Outside lock for sub-code Q resister input	54	PDO	—	"
15	SUBQ	O	Sub-code Q-code output	55	SUBC	O	Subcode serial output data output
16	DMUTE	I	Muting input (H : MUTE)	56	SBCK	—	Clock input for subcode serial output
17	STATUS	O	Status signal (CRC,CUE,CLVS,TTSTOP,ECLV,SQOK)	57	VSS	—	Connected to GND(for X'tal cscillation circuit)
18	RST	I	Reset signal input (L :Reset)	58	X1	I	Input of 16.9344MHz X'tal oscillation circuit
19	SMCK	—	Not used	59	X2	—	Not used
20	PMCK	—	Not used	60	VDD	—	Power supply(for X'tal cscillation circuit)
21	TRV	O	Traverse enforced output	61	BYTCK	—	Not used
22	TVD	O	Traverse drive output	62	CLDCK	O	Subcode · Frame · Clock signal output
23	PC	—	Not used	63	FCLK	O	X'tal frame clock output
24	ECM	O	Spindle motor drive signal (Enforced mode output) 3-State	64	IPPLAG	O	Interpolation flag output H : Interpolation
25	ECS	O	Spindle motor drive signal (Servo error signal output)	65	FLAG	—	Flag output
26	KICK	O	Kick pulse output	66	CLVS	—	Not used
27	TRD	O	Tracking drive output	67	CRC	—	"
28	FOD	O	Focus drive output	68	DEMPH	O	De-emphasis ON signal (H : ON)
29	VREF	I	Reference voltage input pin for D/A output block(TVD,FOD,FBAL,TBAL)	69	RESY	—	Not used
30	FBAL	O	Focus Balance adjust signal output	70	NC1	—	"
31	TBAL	O	Tracking Balance adjust signal output	71	TEST	—	Pull up (+5V)
32	FE	I	Focus error signal input(Analog input)	72	AVDD1	—	Power supply (Digital)
33	TE	I	Tracking error signal input(Analog input)	73	NC2	—	Not used
34	RF ENV	I	RF envelope signal input(Analog input)	74	AVSS1	—	Connected to GND
35	VDET	I	Vibration detect signal input(H : detect)	75	NC3	—	Not used
36	OFT	I	Off track signal input(H : off track)	76	RSEL	I	Rf signal polarity appointed pin Light level "H" → RSEL = H Light level "L" → RSEL = L
37	TRCRS	I	Track cross signal input	77	CSEL	I	X'tal oscillation frequency appointed pin L : 16.9344MHz H : 33.8688MHz
38	RFDET	I	RF detect signal input (L : detect)	78	PSEL	I	Terminal of Test
39	BDO	I	BDO input pin (H : drop out)	79	MSEL	I	SMCK pin output of frequency select terminal L : SMCK + 4.2336MHZ H : SMCK + 8.4672MHZ
40	LDON	O	Laser ON signal output (H : on)	80	SSEL	—	SUBQ terminal output mode select pin H : Mode for Q code buffer

■ MN35503 (IC750) : D / A CONVERTER

1. Terminal Layout

MA	1	28	RDO
DIN	2	27	MD
LRCK	3	26	MC
BCK	4	25	M3
MB	5	24	DVDD1
DVDD2	6	23	XIN
CKO	7	22	XOUT
DVSS2	8	21	DVSS1
M1	9	20	M2
OUT1C	10	19	OUT2C
NC	11	18	NC
AVDD1	12	17	AVDD2
OUT1D	13	16	OUT2D
AVSS1	14	15	AVSS2

2. Block Diagram

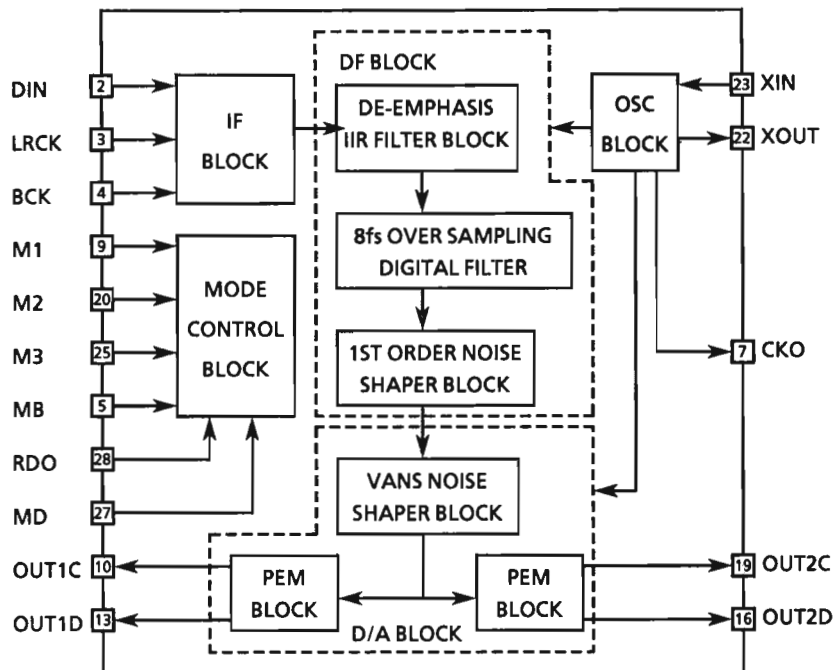

3. Description

Pin No	Symbol	I/O	Description	Pin No	Symbol	I/O	Description
1	MA	--	Connected to ground	15	AVSS2	--	Analog ground 2
2	DIN	I	Data input	16	OUT2D	O	2D PEM output
3	LRCK	I	LR clock input	17	AVDD2	--	Analog power supply 2
4	BCK	I	Bit clock input	18	NC	--	Non connection
5	MB	I	De-emphasis ON signal	19	OUT2C	O	2C PEM output
6	DVDD2	--	Digital power supply 2	20	M2	--	Connected to ground
7	CKO	I	Clock output	21	DVSS1	--	Digital ground pin 1
8	DVSS2	--	Digital ground 2	22	XOUT	O	Crystal oscillator output
9	M1	--	Connected to ground	23	XIN	I	Crystal oscillator input
10	OUT1C	O	1C PEM output	24	DVDD1	--	Digital power supply 1
11	NC	--	Non connection	25	M3	--	Connected to ground
12	AVDD1	--	Analog power supply 1	26	MC	--	Connected to ground
13	OUT1D	O	1D PEM output	27	MD	I	Reset signal / Digital Att. control signal input
14	AVSS1	--	Analog ground 1	28	RDO	--	Not used

■ VC4580D (IC751) : Dual OP Amp.

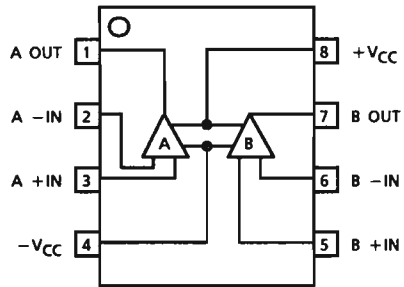

■ MN1281 (P.Q.) : IC902 RESET IC

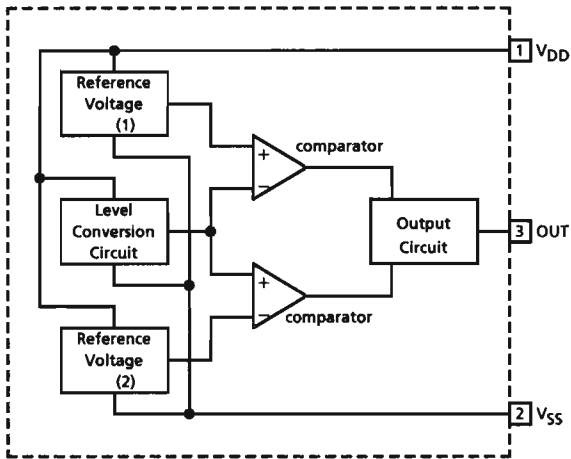

Pin No.	Pin Name	Functions
1	V _{DD}	Power supply
2	V _{SS}	Ground
3	OUT	Reset signal output : Low level is output when resetting : High level is output when cancelling the reset.

Internal Connections of FL Display

■ ELU0001-178:(DI901)

1. Grid Layout

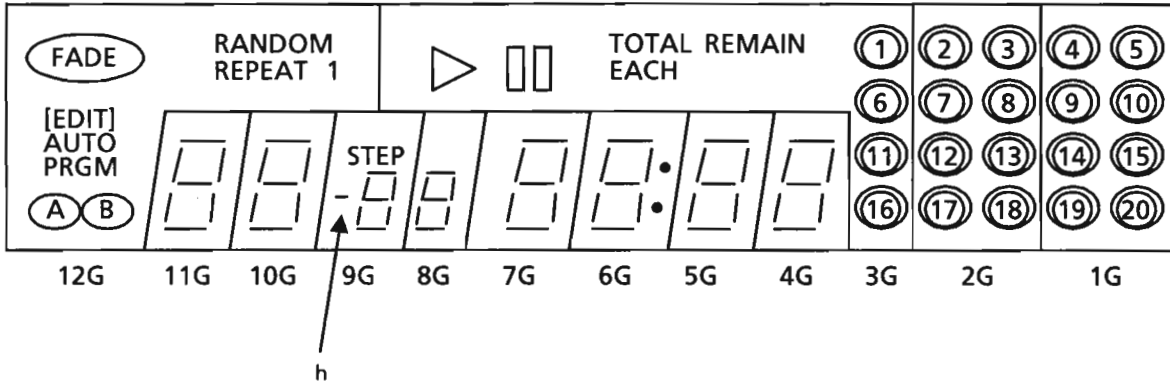

2. Pin Connections

TERMINAL NO.	1	2	3	4	5	6	7	8	9	10	11	12	13	14	15	16	17	18
ELECTRODE	F1	F1	NP	12G	11G	10G	9G	8G	7G	6G	5G	4G	3G	2G	1G	NP	NP	NP

TERMINAL NO.	19	20	21	22	23	24	25	26	27	28	29	30	31	32	33	34	35	36	37
ELECTRODE	NP	NP	NP	NP	NP	NP	NP	S1	S2	S3	S4	S5	S6	S7	S8	S9	NP	F2	F2

(Note) F : Filament G : Grid NP : NoPin NC : No Connection P1~P9 : Anode

3. Anode Designation

	12G	11G	10G	9G	8G	7G	6G	5G	4G	3G	2G	1G
S1	FADE	a	a	a	a	a	a	a	a	①	②	④
S2	[EDIT]	b	b	b	b	b	b	b	b	⑥	⑦	⑨
S3	AUTO	c	c	c	c	c	c	c	c	⑪	⑫	⑭
S4	PRGM	d	d	d	d	d	d	d	d	⑯	⑰	⑲
S5	A	e	e	e	e	e	e	e	e	▶	③	⑤
S6	B	f	f	f	f	f	f	f	f		⑧	⑩
S7	RANDOM	g	g	g	g	g	g	g	g	TOTAL	⑬	⑮
S8	REPEAT	---	---	STEP	---	---	●●	---	---	EACH	⑱	⑳
S9	1	---	---	(-)	---	---	---	---	---	REMAIN	---	---

Disassembly Procedures

- (1) Top cover removal
1. Remove the 4 screws ① on the rear side and 2 screws ② on both sides of the cover.
 2. Remove the cover.

- (2) Rear panel removal
1. Remove the top cover.
 2. Remove the 2 screws ③. Disconnect the CN601. (Fig.3)
 3. Remove the rear panel.

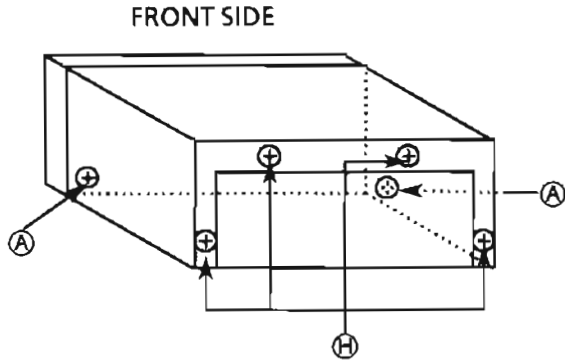

Fig.1

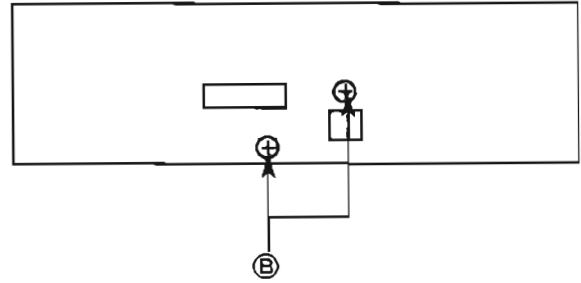

Fig.2

- (3) Tray assembly removal
1. Remove the top cover.
 2. Remove the a screw ⑥.
 3. Tune the screw located under the mechanism to remove the tray out of the loading mechanism.
 4. Remove the tray.

- (4) Front panel assembly removal
1. Remove the top cover and tray assembly.
 2. Disconnect the CN701 and CN702. (Fig.3)
 3. Remove the 2 screws ⑦.
 4. Release the hooks ⑧ holding the front panel, and remove the front panel assembly.

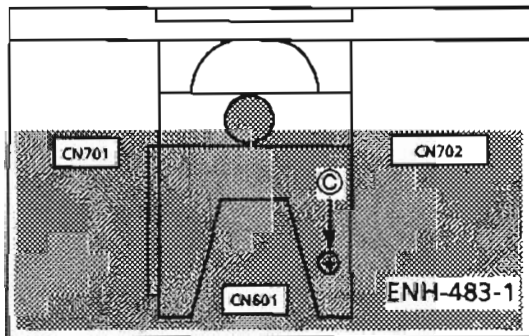

Fig. 3 UP SIDE

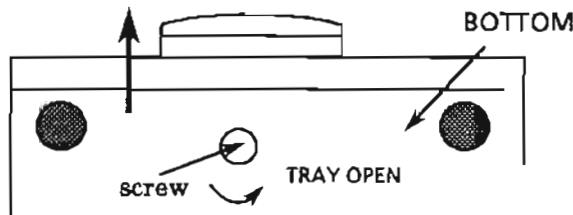

Fig. 4

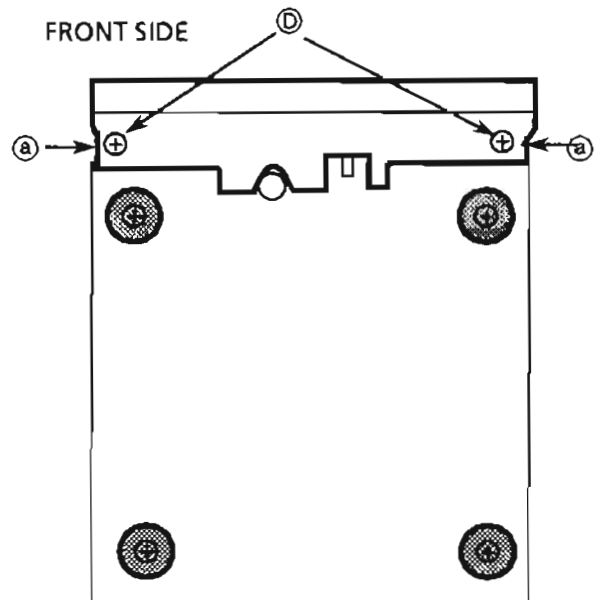

Fig. 5

- ① .. SDSG3008N ② ... E73273-003 ③ ... SBSF3008Z ④ ... SDSG3008CC
 ⑤ .. GBSB3008CC

(5) CD mechanism assembly removal

1. Remove the top cover and tray assembly.
2. Remove the 2 screws (C) to remove the clamp assembly.
3. Remove the 3 screws (E) holding the CD mechanism assembly.
4. Disconnect the CN102, CN103 and CN104.
5. Remove it.

(6) Main PCB(ENN-483-1) removal

1. Remove the top cover, tray assembly, rear panel and CD mechanism assembly.
2. Remove the 4 screws (F) holding the Main PCB (ENN-483-1).
3. Remove it.

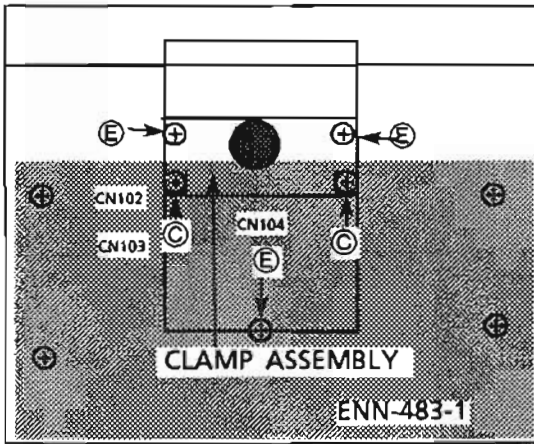

Fig.6

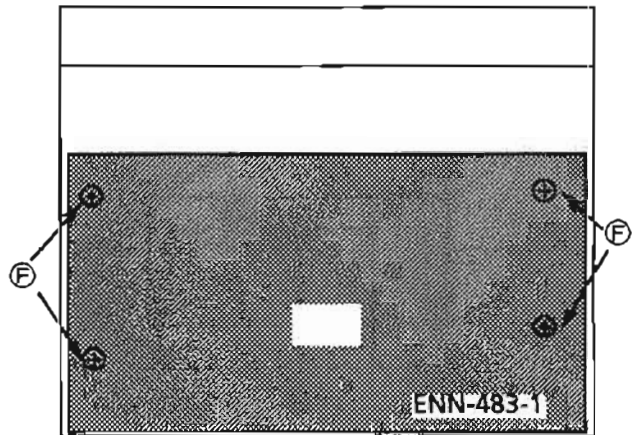

Fig.7

(7) Front PCB(ENN-483-2) removal

1. Remove the top cover, tray assembly and front panel assembly.
2. Remove the 5 screw (G).
3. Remove the Front PCB (ENN-483-2).

(8) Installing the CD tray

1. Insert the CD tray after checking that traverse mechanism assembly is positioned slantingly.
2. If it is set horizontally, press the cam plate until it stops so that the traverse mechanism assembly slants. (See an arrow in the following figure.)

Front panel assembly

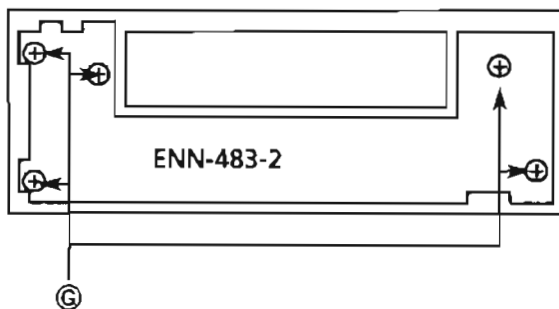

Fig. 8

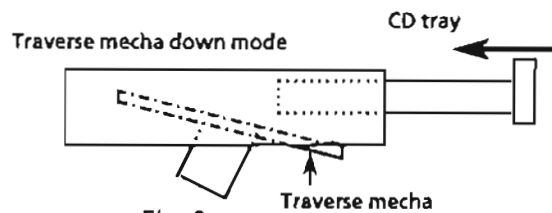
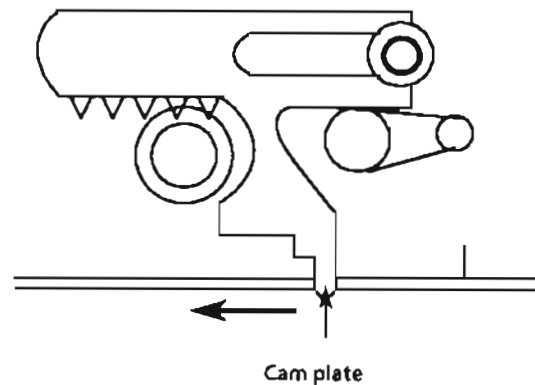

Fig. 9

(C) .. SBSF3008Z (E) ... SBST3008Z (F) ... SBSG3006CC (G) ... SDSF2608Z

(9) Pickup removal

1. Remove the CD mechanism assembly.
2. Release the shaft to remove the pickup. (Fig 10)

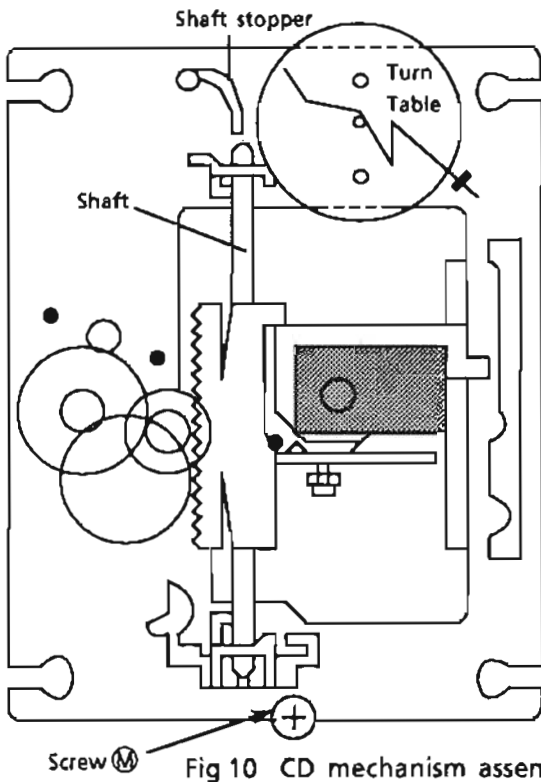

Fig 10 CD mechanism assembly

(10) Spindle motor removal

1. Remove the CD mechanism assembly.
2. Remove the turntable, and remove the two screws (N) retaining the spindle motor.
3. Remove the a screw retaining the spindle and feed motor P.C. Board and unsolder it.

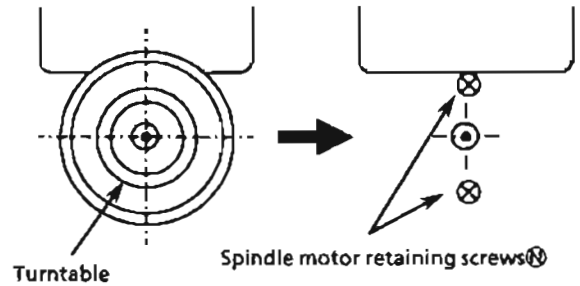

Fig 11

- (12)**After inserting the turntable, bond the motor shaft and turntable together (at the section marked by an arrow in fig 13 on the left below).

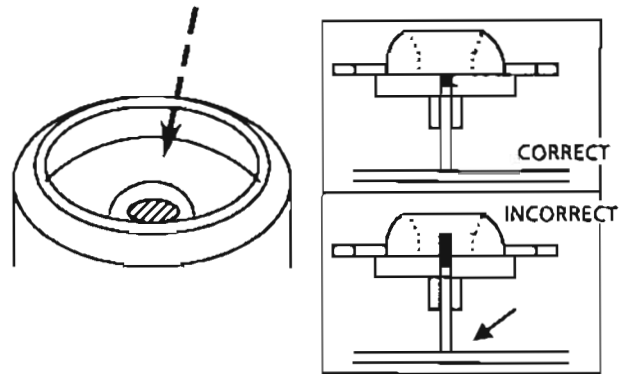

Fig 13

(11) Spindle motor installation

1. Tighten the 2 screws to the same torque.
2. Fasten the spindle and feed motor P.C. board with the screw and solder.
3. Install the turntable. When installing, press straight down at the center of the turntable until the distance from the surface of the mechanism base to the turntable is exactly $19.4 \pm 0.1\text{mm}$.

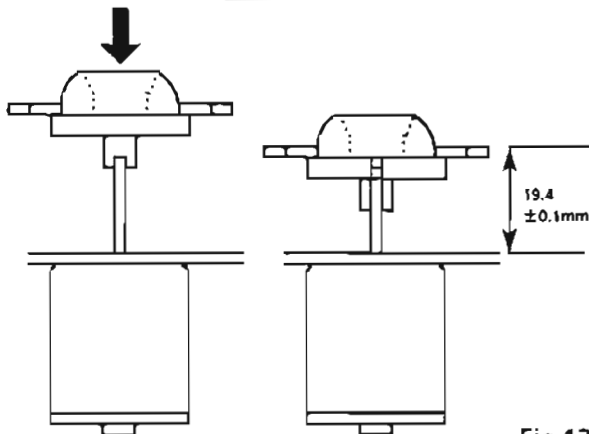
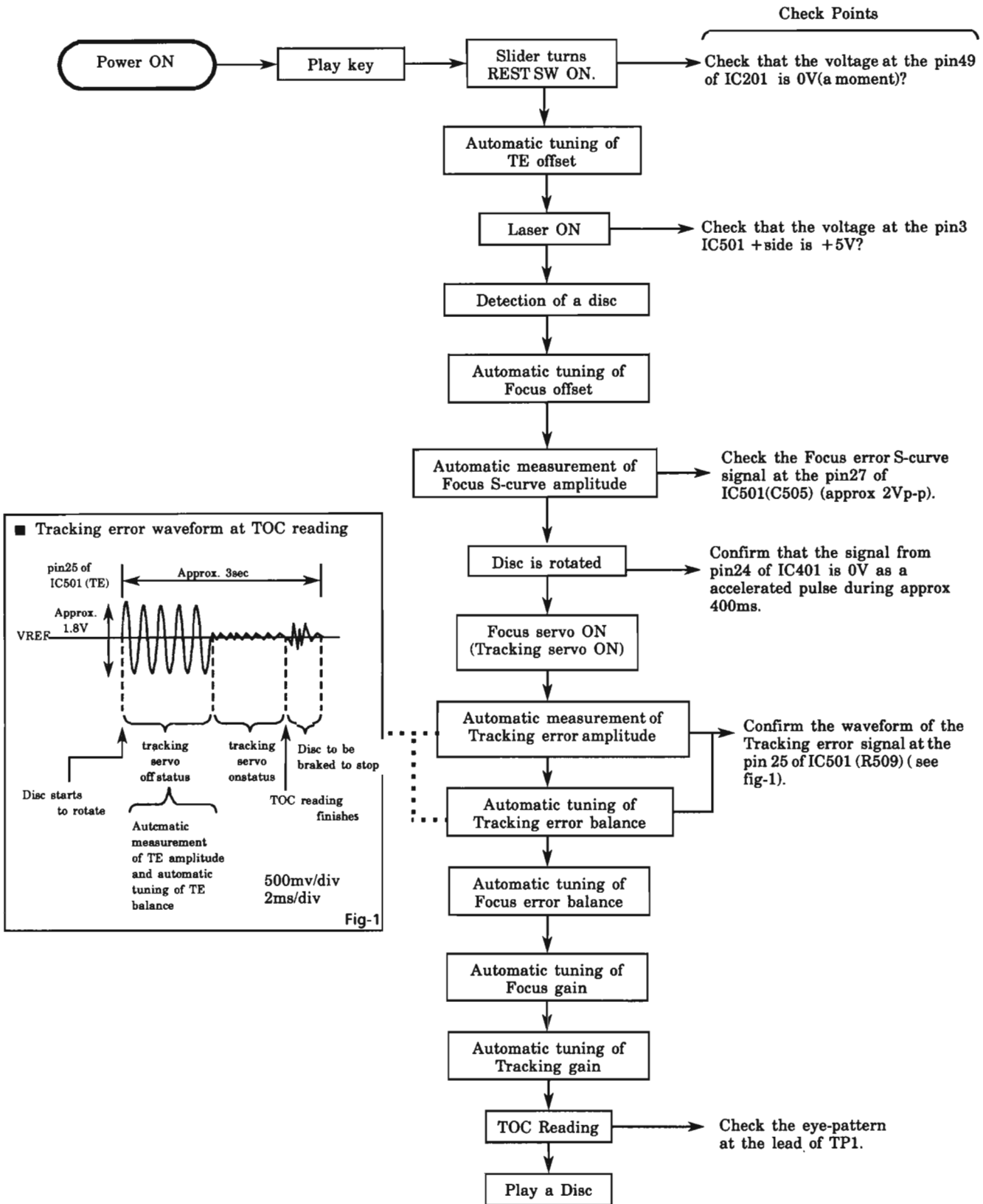

Fig 12

- (13)**Use "LOCKTITE" #460 bonding agent, and apply as little as possible. Take care not to allow any excess bonding agent to get onto the turntable. Be extremely careful not to allow bonding agent to adhere to the motor bearing (the section marked by an allow in fig 13 on the right).

Flow of Functional Operation Until TOC is Read



Maintenance of Laser Pickup

(1) Cleaning the pick up lens

Before you replace the pick up, please try to clean the lens with a alcohol soaked cotton swab.

(2) Life of the laser diode (Fig.1)

When the life of the laser diode has expired, the following symptoms will appear.

- (1) The level of RF output (EFM output: amplitude of eye pattern) will be low.
- (2) The drive current required by the laser diode will be increased. In such a case, check the life of the laser diode following the flowchart below.

(3) Measurement of laser diode drive current (Fig.2)

Cut the jump wire (B107) and add a 1Ω resistor. (See the following Fig,2)

Measure the voltage across the resistor (1Ω) with a milli-voltmeter. When the voltage is more than 120mV, it shows that the life of the laser diode has expired.

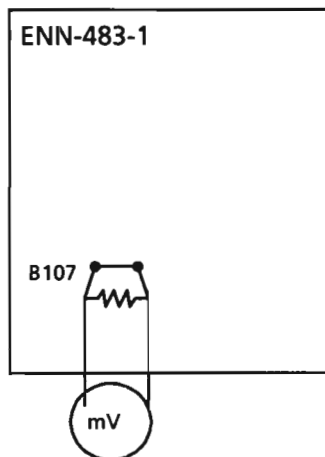

(Fig.2)

Replacement of Laser Pickup

Turn off the power switch and, disconnect the power cord from the ac outlet.

Replace the pickup with a normal one. (Refer to "Pickup Removal" on the previous page)

Plug the power cord in, and turn the power on. At this time, check that the laser emits for about 3seconds and the objective lens moves up and down.
Note: Do not observe the laser beam directly.

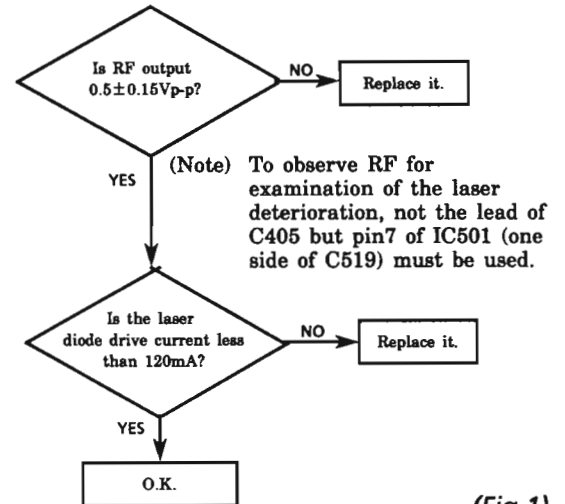

(Fig.1)

(4) Semi-fixed resistor on the APC PC board

The semi-fixed resistor on the APC printed circuit board which is attached to the pickup is used to adjust the laser power. Since this adjustment should be performed to match the characteristics of the whole optical block, do not touch the semi-fixed resistor.

If the laser power is lower than the specified value, the laser diode is almost worn out, and the laser pickup should be replaced.

If the semi-fixed resistor is adjusted while the pickup is functioning normally, the laser pickup may be damaged due to excessive current.

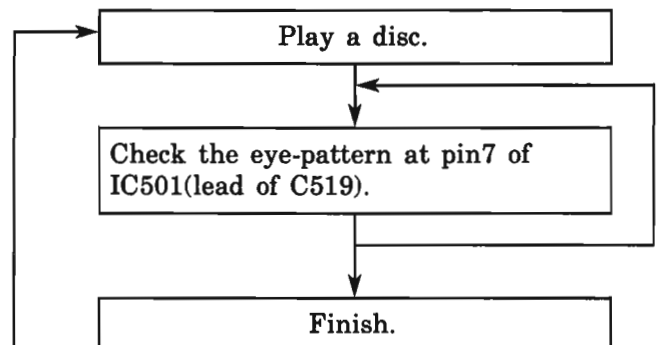

Self-diagnosis for pickup

From DCS output, this model reads automatically adjusted data for CD so that the pickup can be judged defective or not. Following shows its details.

1. Necessary items

- ① DCS → 232C Converting board (No.EBSJ1022)
- ② 232C cord (straight)
- ③ Floppy disc for self-diagnosis (No.EBSJ1022)
- ④ DCS cord
- ⑤ Cord of Power supply (E407992-001)
- ⑥ Power supply DC 6.3V (AA-SV11J--America/Canada) (AA-SV11Bs--the UK)
(AA-SV11G--Germany) (AA-SV11EF--Continental Europe) (AA-SV11U--the
Other aria)
- ⑦ CD (without scratches or damage)

2. Connection

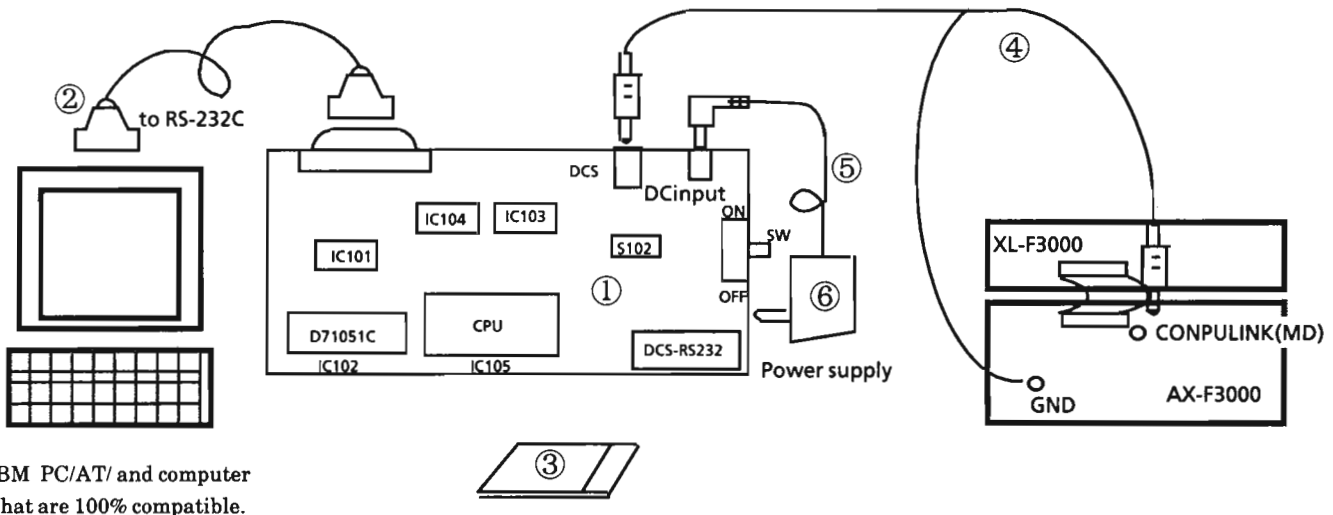

3. Procedure to use CD self-diagnosis jig by IBM PC

Two com pins are frequently adopted in recent IBM AT and its substitute RS232C port.

This jig can also use both COM1 and COM2.

DEFAULT is COM1. Indicate "2" to the option only for COM2.

When COM1 is used,...

I AUTO 01

When COM2 is used,...

I AUTO 02

[NOTE] Press ESC key to stop processing during the operation.

Contents of the attached floppy IBM self-diagnosis program VER.1.00 Execution file.

(Mistake the conection/Mistake the polarity)

4. Judgment

To judge whether pickup is defective or not, firstly process of automatic adjustment is checked by automatic adjustment flag. And, the value(automatic adjustment value for focus gain) displayed on the screen is used for its final judgment.

It is supposed that the pickup is defective or the signal path is faulty if the Flag 1 or Flag 0 indicates not "F" but a figure.

(See the following example.)

Flag 1	Flag 0	Details	Supposed cause
0	0	Automatic adjustment for tracking offset is failed.	The automatic adjustment is not completed. (Trouble in circuit.)
0	1	Automatic adjustment for focus offset is failed. (Disc does not rotate.)	The lens does not move. (Power supply is not turned on. Wire is cut.)
0	3	Automatic rough adjustment for focus gain is failed.	
0	7	Automatic rough adjustment for tracking gain is failed. (The focus and tracking gain are not locked though the disc rotates.)	Laser deterioration (low RF signal output). Offset beam.
0	F	Disc rotates, focus and tracking gain are locked and automatic rough adjustment for tracking gain is also completed though automatic adjustment for tracking balance is failed.	Laser deterioration (low RF signal output). Offset beam.
1	F	Automatic adjustment for focus balance is failed. (TOC is not read though the disc rotates.)	RF signal output is low. Tracking loop is not turned on. RF jitter is too much.
3	F	Automatic rough adjustment for focus gain is failed.	
7	F	Automatic rough adjustment for tracking gain is failed.	
F	F	All automatic adjustments are completed.	

The pickup is judged defective though the Flag 0 and Flag 1 indicate "F" and those adjustments are completed if the adjustment value exceeds 19dB.

Block Diagram

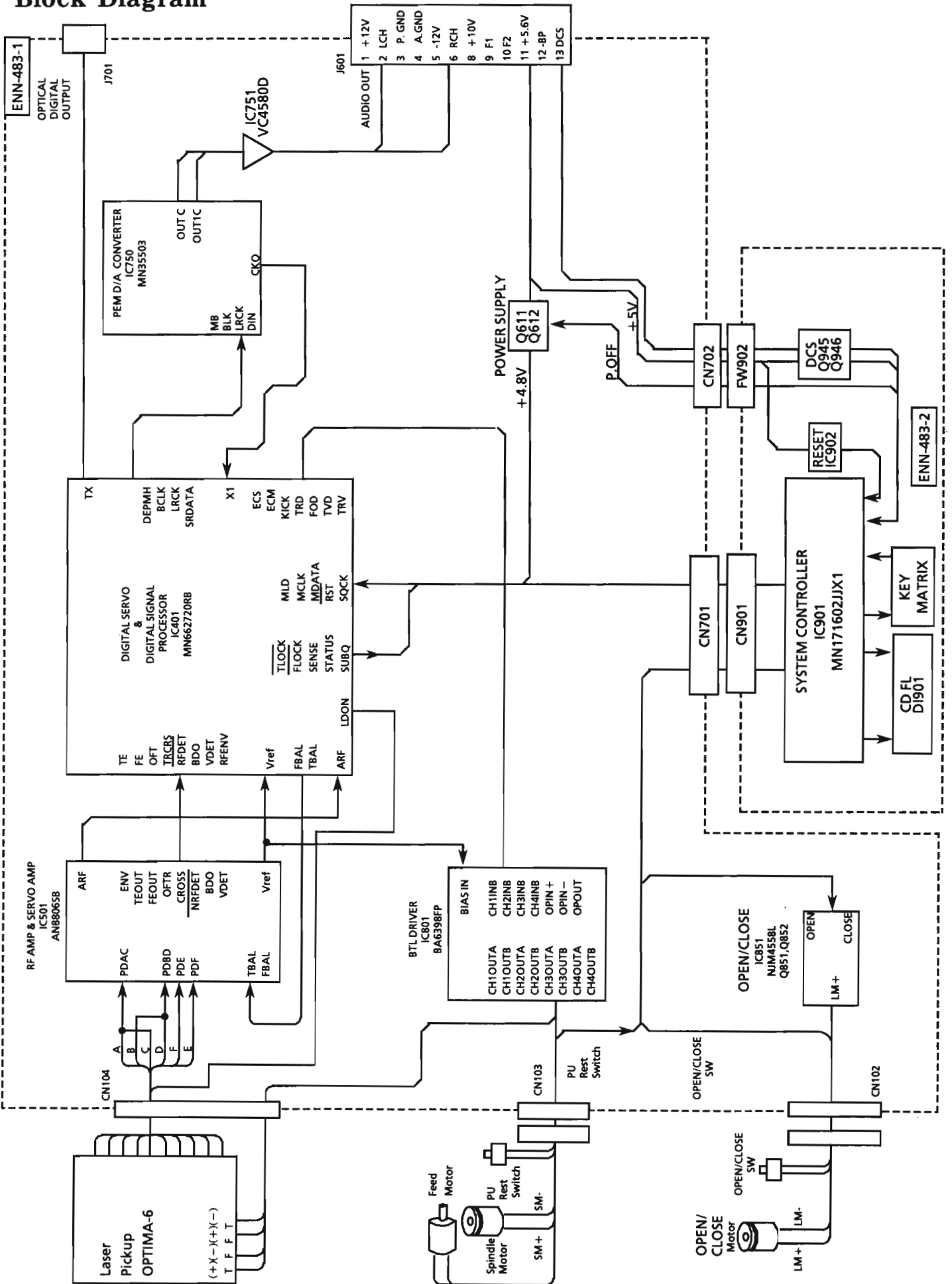

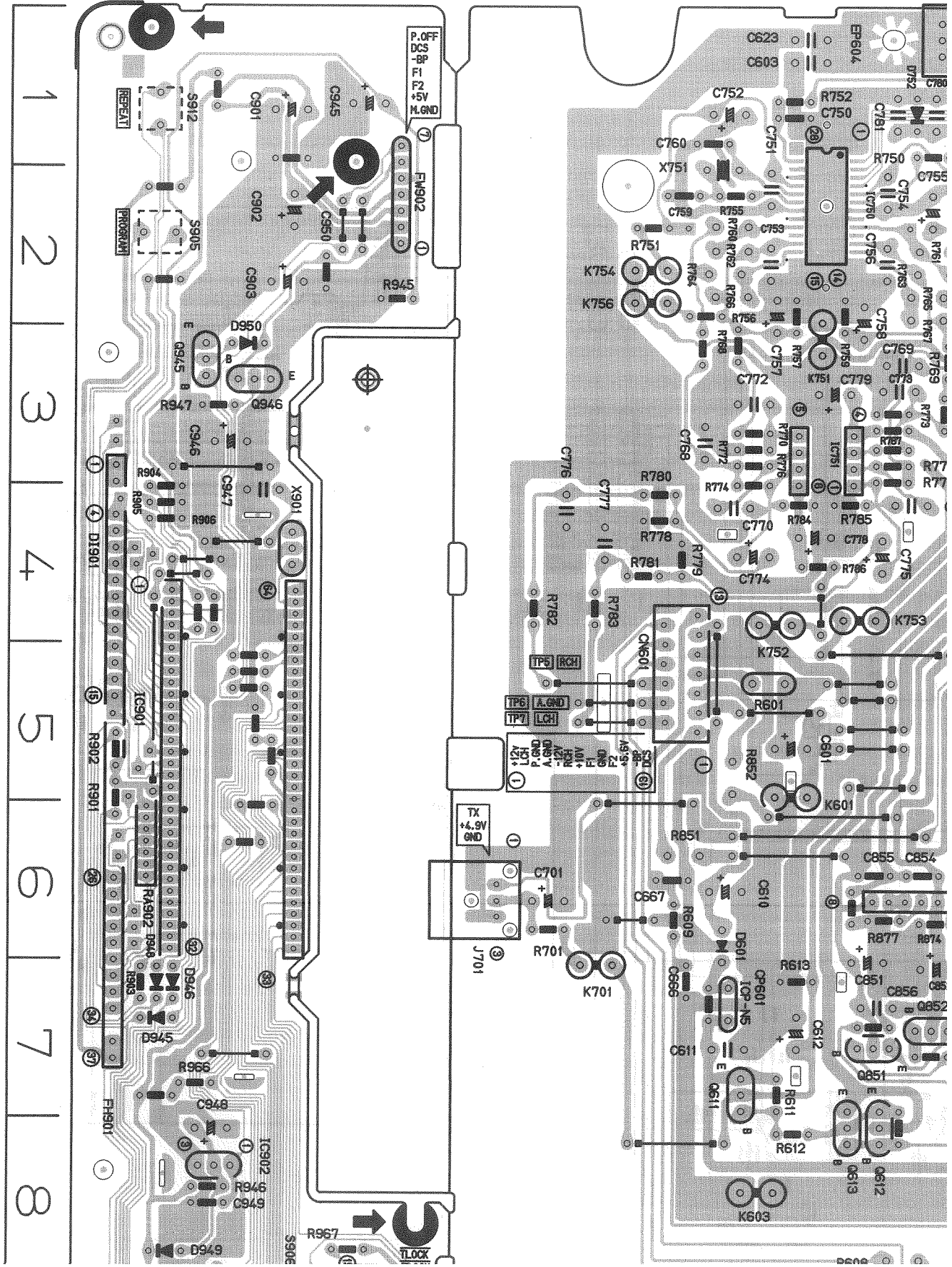

Printed Circuit Board

■ Main P.C. Board (ENN-483)

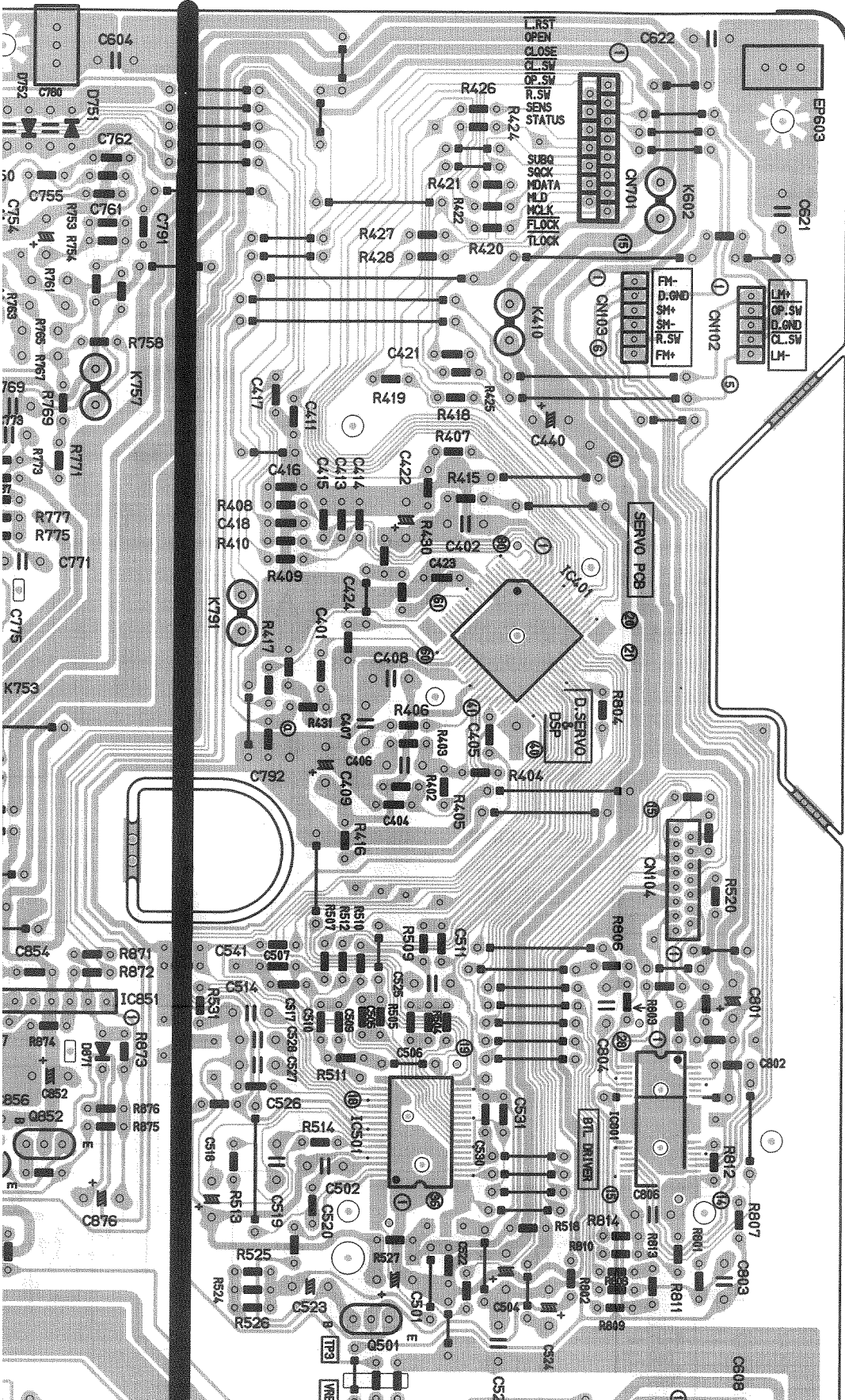

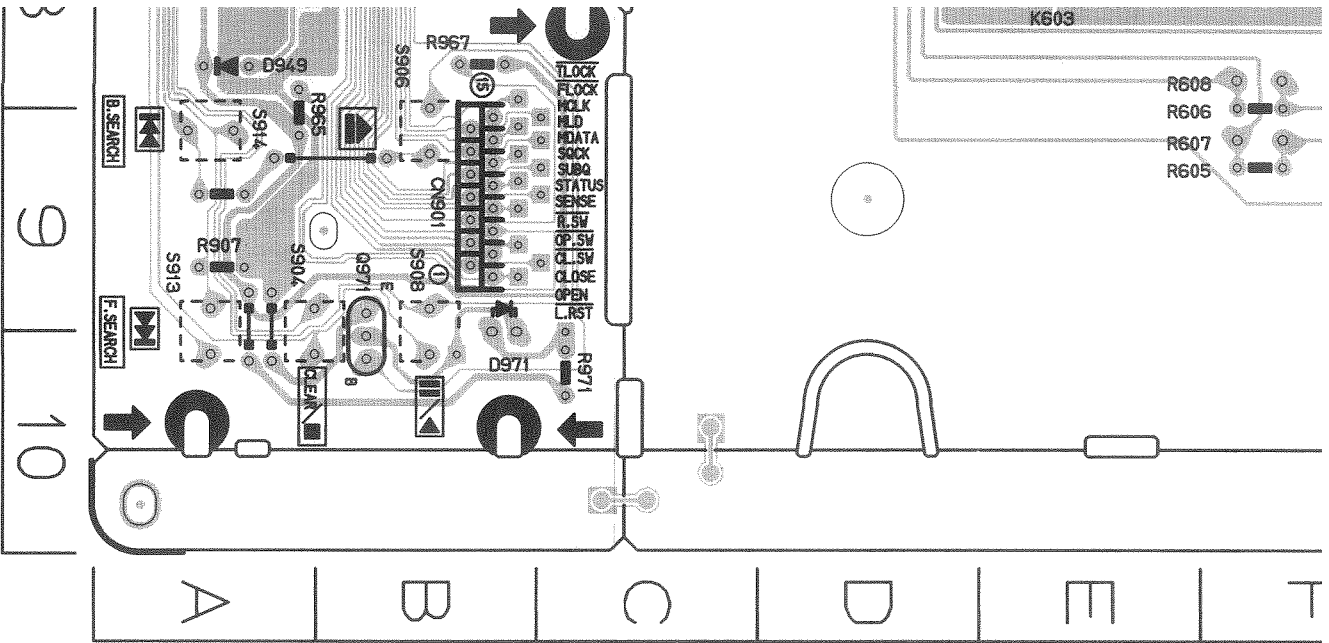

0607	6 G	C775	4 F	J701	6 C	R514	7 G	R803	6 I
0609	6 H	C776	4 D	K410	2 I	R518	7 I	R804	4 I
0610	6 H	C777	4 D	K601	5 E	R520	5 J	R806	6 I
0611	6 H	C778	4 E	K602	1 I	R524	8 G	R807	7 J
0614	6 G	C779	3 E	K603	8 E	R525	8 G	R808	8 I
0617	6 G	C780	1 F	K701	7 D	R526	8 G	R809	8 I
0618	7 G	C781	1 F	K702	9 I	R527	7 H	R810	8 I
0619	7 G	C791	2 F	K703	9 I	R531	6 G	R811	7 J
0620	7 G	C792	5 G	K704	9 I	R601	5 E	R812	7 J
0622	8 H	C801	6 J	K705	10 I	R605	9 F	R813	8 I
0623	8 G	C802	6 J	K751	2 E	R606	9 F	R814	7 I
0624	8 I	C803	8 J	K752	4 E	R607	9 F	R851	6 D
0625	6 H	C804	6 I	K753	4 E	R608	8 F	R852	5 E
0626	7 G	C806	7 I	K754	2 D	R609	6 D	R871	6 F
0627	6 G	C851	7 E	K756	2 D	R611	7 E	R872	6 F
0628	6 G	C852	7 F	K757	3 F	R612	8 E	R873	6 F
0629	8 I	C854	6 F	K791	4 G	R613	7 E	R874	6 F
0630	7 H	C855	6 E	0501	8 H	R701	6 C	R875	7 F
0631	7 I	C856	7 E	0611	7 E	R750	1 F	R876	7 F
0641	6 G	C876	7 F	0612	8 F	R751	2 D	R877	6 F
0601	5 E	C901	1 B	0613	8 E	R752	1 E	R901	5 A
0602	9 J	C902	2 B	0851	7 E	R753	2 F	R902	5 A
0603	1 E	C903	2 B	0852	7 F	R754	2 F	R903	7 A
0604	1 F	C945	1 B	0945	3 A	R755	2 E	R904	4 A
0605	9 F	C946	3 A	0946	3 B	R756	2 D	R905	4 A
0606	9 G	C947	4 B	0971	10 B	R757	2 E	R906	4 A
0607	9 F	C948	8 A	R402	5 H	R758	2 F	R907	9 A
0608	8 J	C949	8 A	R403	5 H	R759	2 E	R945	2 B
0609	9 J	C950	2 B	R404	5 H	R760	2 E	R946	8 A
0610	6 E	CN102	2 J	R405	5 H	R761	2 F	R947	3 A
0611	7 E	CN103	2 I	R406	5 H	R762	2 E	R965	8 A
0612	7 E	CN104	6 J	R407	3 H	R763	2 F	R966	7 A
0621	2 J	CN601	4 D	R408	3 G	R764	2 E	R967	8 B

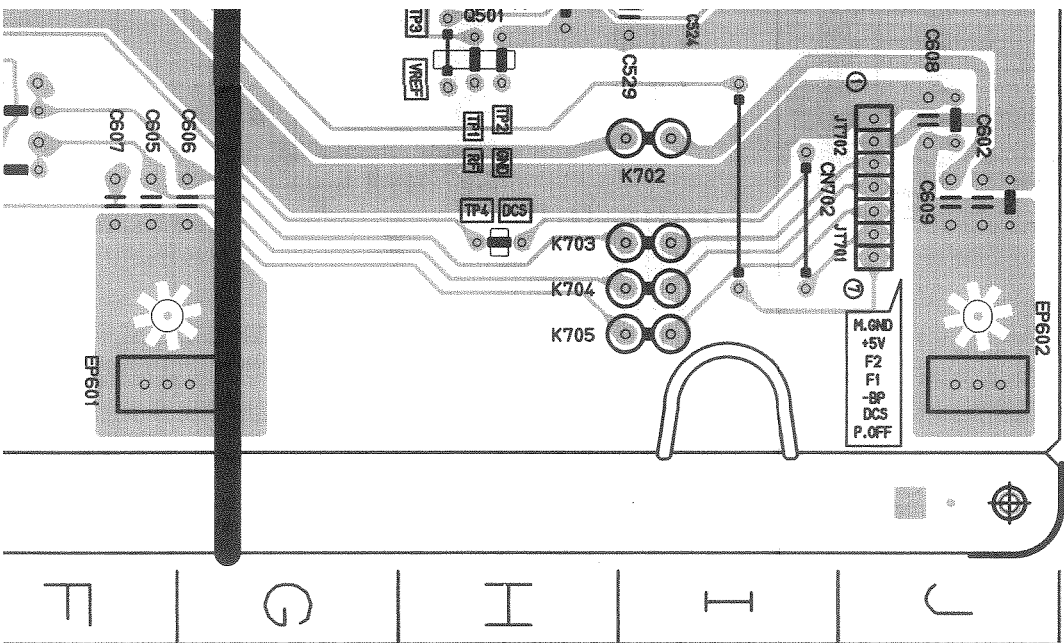

Location List (ENN-483)

Symbol	X	Y	Symbol	X	Y	Symbol	X	Y	Symbol	X	Y	Symbol	X	Y
C401	4	H	G622	1	J	GN701	2	I	R409	4	G	R765	2	F
C402	3	H	G623	1	E	GN702	9	J	R410	4	G	R766	2	E
C404	5	H	G666	7	D	GN901	9	B	R415	3	H	R767	2	F
C405	5	H	G667	6	D	GP601	7	E	R416	5	H	R768	3	E
C406	5	H	G701	6	C	D601	6	E	R417	4	G	R769	3	F
C407	4	H	G750	1	E	D751	1	F	R418	3	H	R770	3	E
C408	4	H	G751	2	E	D752	1	F	R419	3	H	R771	3	F
C409	5	H	G752	1	E	D871	6	F	R420	2	H	R772	3	E
C411	3	G	G753	2	E	D945	7	A	R421	1	H	R773	3	F
C413	3	H	G754	2	F	D946	7	A	R422	2	H	R774	4	E
C414	3	H	G755	2	F	D948	7	A	R424	1	H	R775	3	F
C415	3	H	G756	2	F	D949	8	A	R425	3	H	R776	3	E
C416	3	G	G757	3	E	D950	3	A	R426	1	H	R777	3	F
C417	3	G	G758	3	E	D971	10	B	R427	2	H	R778	4	D
C418	3	G	G759	2	D	D1901	3	A	R428	2	H	R779	4	D
C421	2	H	G760	1	D	FH901	8	B	R430	3	H	R780	4	D
C422	3	H	G761	2	F	FW902	2	C	R431	4	G	R781	4	D
C423	4	H	G762	1	F	IC401	4	I	R504	6	H	R782	4	C
C424	4	H	G768	3	D	IC501	7	H	R505	6	H	R783	4	D
C440	3	I	G769	3	F	IC750	2	E	R507	6	H	R784	4	E
C501	8	H	G770	4	E	IC751	4	E	R509	6	H	R785	4	E
C502	7	G	G771	4	F	IC801	7	I	R510	6	H	R786	4	E
C504	8	I	G772	3	E	IC851	6	F	R511	6	H	R787	3	F
C505	6	H	G773	3	F	IC901	4	A	R512	6	H	R801	8	J
C506	6	H	G774	4	E	IC902	8	B	R513	7	G	R802	8	I
C507	6	G	G775	4	F	J701	6	C	R514	7	G	R803	6	I
C509	6	H	G776	4	D	K410	2	I	R518	7	I	R804	4	I

Symbol	X	Y
R971	10	C
RA902	6	A
S904	10	A
S905	2	A
S906	9	B
S908	10	B
S912	1	A
S913	10	A
S914	9	A
X751	2	D
X901	4	B

P3-18-a

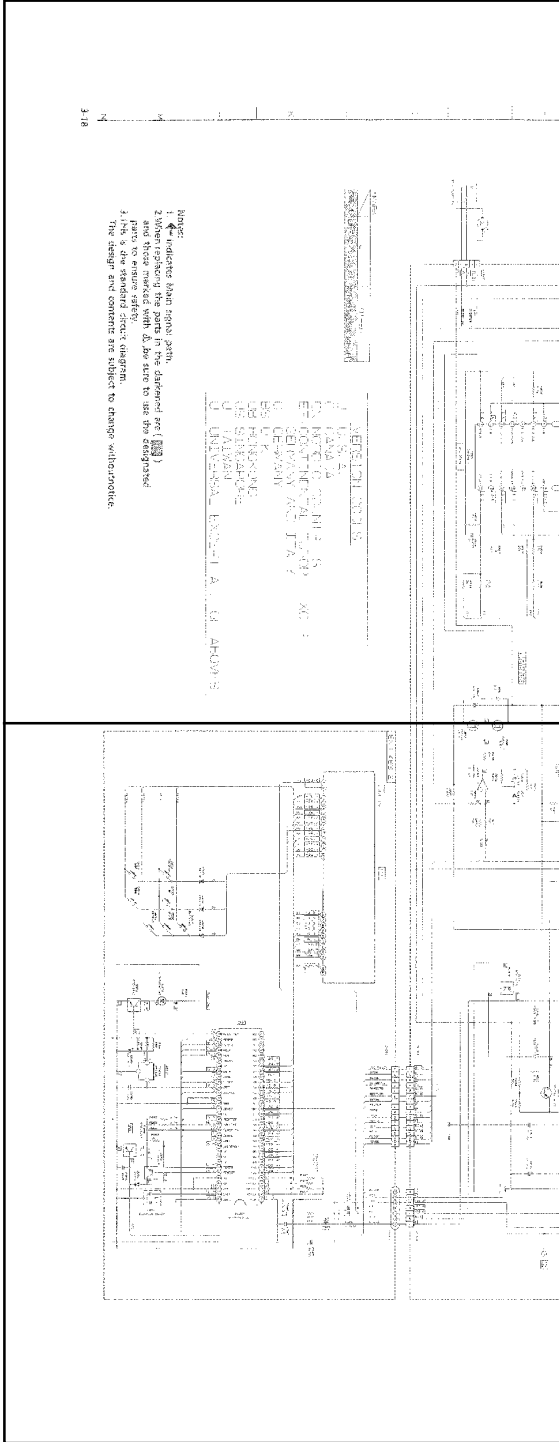

3-18

Note:
 1. This diagram is for information only.
 2. Where applicable, the parts in this diagram are shown in their original configuration and their markings with dimensions to use the designated parts to ensure safety.
 3. This diagram is subject to change without notice.
 The design and content are subject to change without notice.

P3-18-c

P3-18-b

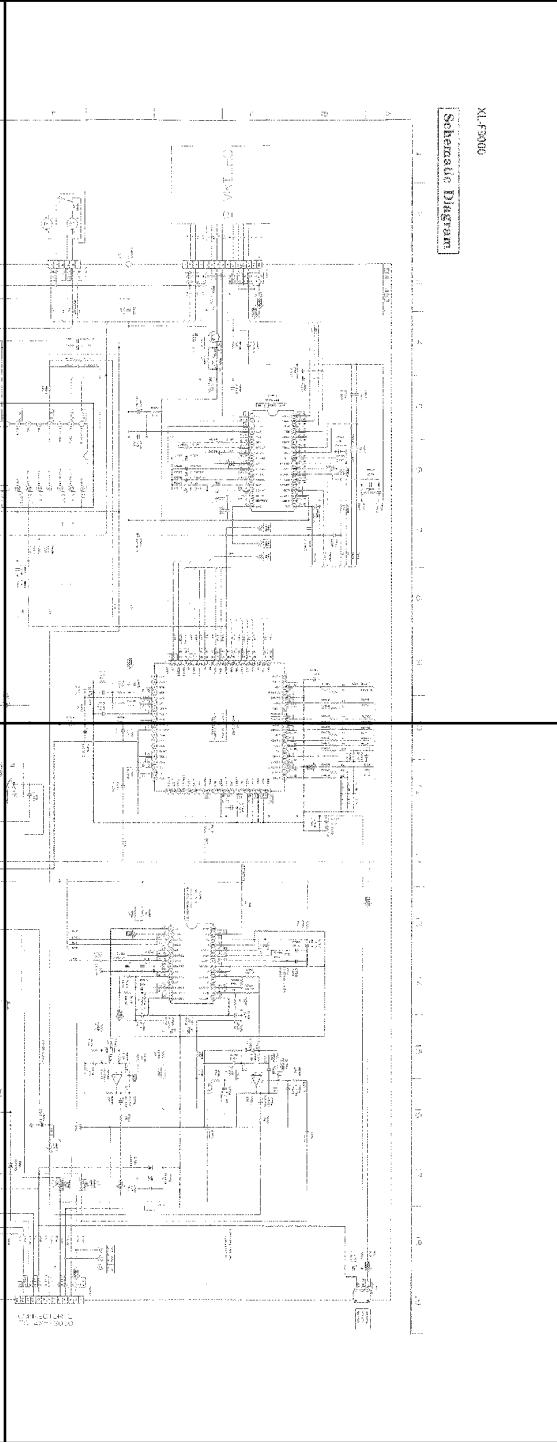

P3-18-d

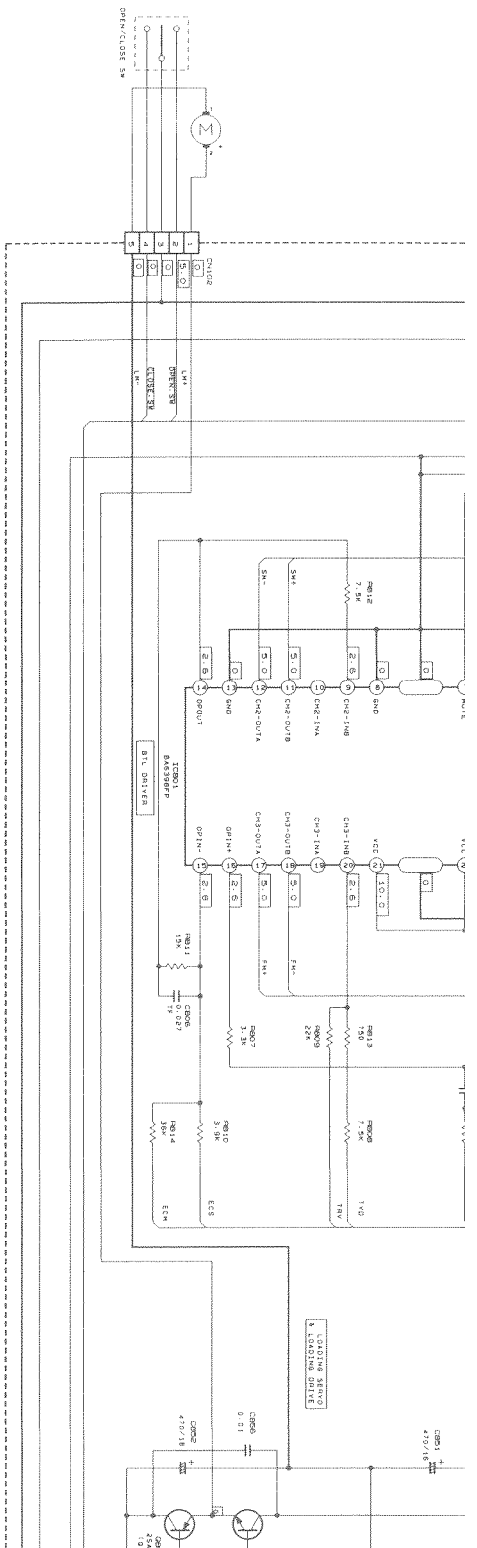

*MARK	J	OTHER
R801	UNF. C. (1/2W)	PTH61625AR4R7M

VERSION CODES	
J	: U.S.A.
C	: CANADA
EN	: NORDIC COUNTRIES
EF	: CONTINENTAL EUROPE EXCEPT GERMANY AND ITALY
G	: GERMANY
BS	: U.K.
UB	: HONGKONG
US	: SINGAPORE
UT	: TAIWAN
U	: UNIVERSAL EXCEPT ALL OF ABOVE

- Notes:
1. indicates Main signal path.
 2. When replacing the parts in the darkened are () and those marked with , be sure to use the designated parts to ensure safety.
 3. This is the standard circuit diagram. The design and contents are subject to change without notice.

G
I
H
J
K
L
M
N

Schematic Diagram

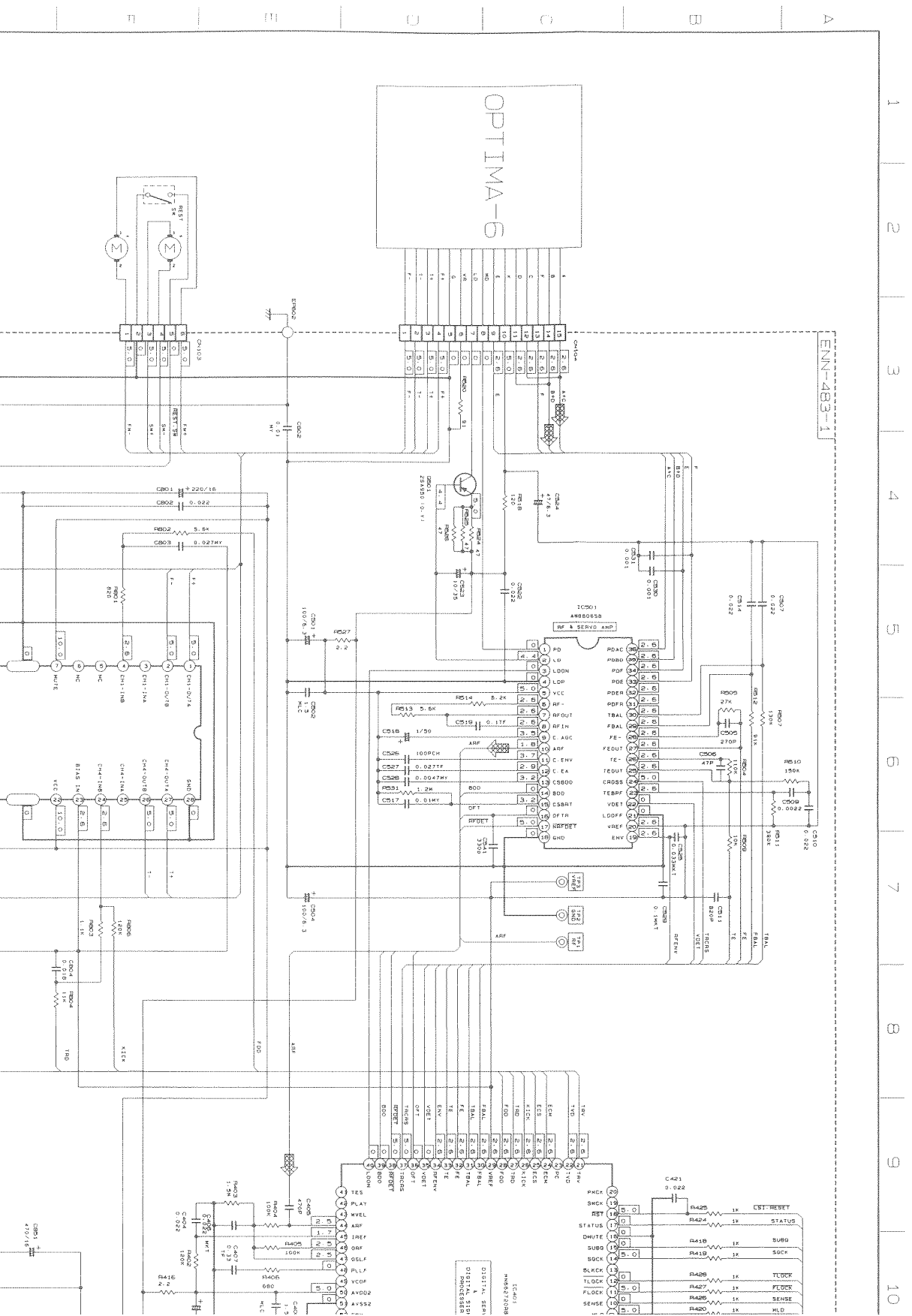

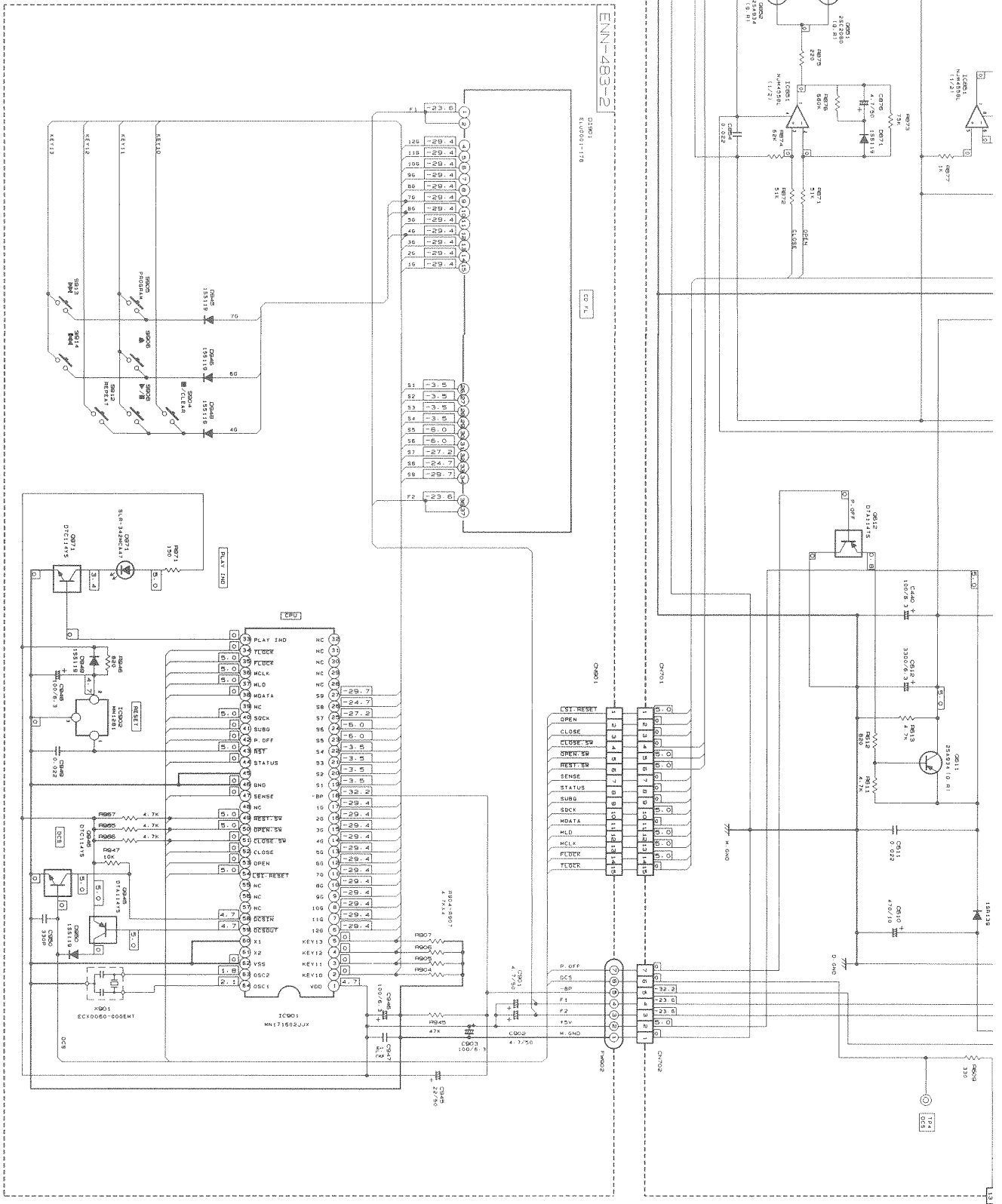

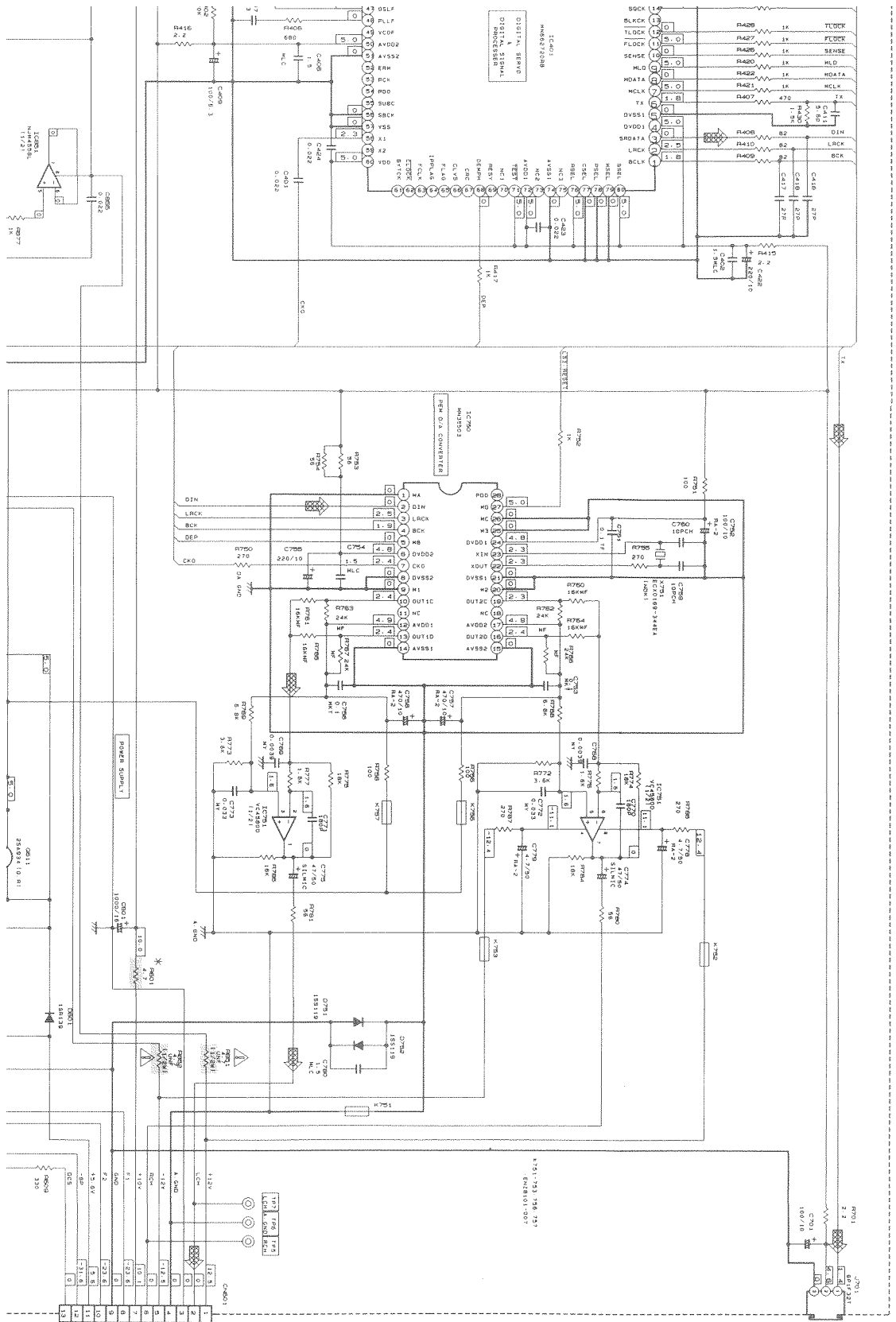

CONNECTOR-C
TO AX-F3000

OPTICAL
DISPENSER

TD-F3000

Contents

<i>Description of Major ICs</i>	4-2
<i>Disassembly Procedures</i>	4-5
<i>Adjustment Procedures</i>	4-10
<i>Block Diagram</i>	4-13
<i>Printed Circuit Boards</i>	4-14
<i>Schematic Diagrams</i>	4-15

Description of Major LSIs

■ HD614081SE39 (IC203) : Deck controller

Terminal Layout

NR LED	1	64	A.FWD. LED
NR LED(C)	2	63	A. REV. LED
A SPEED UP	3	62	B FWD. LED
B SPEED UP	4	61	B.REV. LED
MUSIC IN	5	60	REC LED
B.FWD.REEL MOTOR	6	59	REV. MODE
B.REV.REEL MOTOR	7	58	BIAS
B REV CAM MOTOR	8	57	NR OFF
B FWD CAM MOTOR	9	56	REC MUTE
A CAM SW-2	10	55	DCS IN
A CAM SW-1	11	54	DCS OUT
A CAM SW-0	12	53	GND
A PULSE IN	13	52	4.19MHzOSC IN
B CAM SW-2	14	51	4.19MHzOSC IN
B CAM SW-1	15	50	TO VCC
B CAM SW-0	16	49	RESET IN
B PULSE IN	17	48	KEY&SW IN-4
POWER OFF IN	18	47	KEY&SW IN-3
GND	19	46	KEY&SW IN-2
A FWD REEL MOTOR	20	45	KEY&SW IN-1
A REV REEL MOTOR	21	44	KEY OUT-4
A REV CAM MOTOR	22	43	KEY OUT-3
A FWD CAM MOTOR	23	42	KEY OUT-2
NR REC	24	41	KEY OUT-1
A MUTE	25	40	SWOUT-2
B MUTE	26	39	SWOUT-1
PLAY MUTE	27	38	HI-SPEED DUBBING
CAP.MOTOR ON	28	37	H.S.CrO2
REC	29	36	H.S. ME
FADE CTRL.	30	35	H.S.NORM.
BEQ	31	34	CrO2
+5V	32	33	METAL

Key matrix

	KEY&SW-1 (PIN45)	KEY&SW-2 (PIN46)	KEY&SW-3 (PIN47)	KEY&SW-4 (PIN48)
KEY OUT 1 (PIN41)	A ◀ (S300)	A ◀◀ (S301)	A ▶▶ (S302)	A ▶ (S303)
KEY OUT 2 (PIN42)	B ◀ (S310)	B ◀◀ (S311)	B ▶▶ (S312)	B ▶ (S313)
KEY OUT 3 (PIN43)	A ■ (S320)	B ■ (S321)	REC PAUSE (S322)	—
KEY OUT 4 (PIN44)	A▶▶B (S330)	DOLBY (S331)	REV. MODE (S332)	CD REC (S333)
SW OUT 1 (PIN39)	—	B CrO2	METAL	—
SW OUT 2 (PIN40)	B PACK	REV REC	FWD REC	A PACK

Terminal Description

Pin NO.	Symbol	I/O	Function	Pin NO.	Symbol	I/O	Function
1	NR LED	O	Dolby B indicator signal output	33	METAL	O	Metal tape , normal speed record
2	NR LED(C)	O	Dolby C indicator signal output	34	CrO ₂	O	CrO ₂ tape , normal speed record
3	A S UP	O	Reel speed up control (Deck A)	35	HS NORM	O	Not used
4	B S UP	O	Reel speed up control (Deck B)	36	HS METAL	O	Metal tape , high speed record
5	MUSIC IN	I	Music scan signal input	37	HS CrO ₂	O	CrO ₂ tape , high speed record
6	B F R M	O	Reel control signal for forward (Deck B)	38	HI DUB	O	Not used
7	B R R M	O	Reel control signal for reverse (Deck B)	39	SW O1	O	Keymatrix output for leaf switch
8	B R C M	O	Cam control signal for reverse (Deck B)	40	SW O2	O	Keymatrix output for leaf switch
9	B F C M	O	Cam control signal for forward (Deck B)	41	KEY O1	O	Key matrix output
10	A C SW2	I	Cam data input	42	KEY O2	O	Key matrix output
11	A C SW1	I	Cam data input	43	KEY O3	O	Key matrix output
12	A C SW0	I	Cam data input	44	KEY O4	O	Key matrix output
13	A.PULS IN	I	Reel pulse input from deck A	45	KEY/SW 11	I	Key matrix input
14	B C SW2	I	Cam data input	46	KEY/SW 12	I	Key matrix input
15	B C SW1	I	Cam data input	47	KEY/SW 13	I	Key matrix input
16	B C SW0	I	Cam data input	48	KEY/SW 14	I	Key matrix input
17	B.PULSE IN	I	Reel pulse input from deck B	49	RESET	I	Reset input
18	P.CONT	I	Inhibit input from system controller	50	TO VCC	--	Connected to VCC
19	GND	--	GND	51	OSC	--	Oscillation terminal
20	A F R M	O	Reel control signal for forward (Deck A)	52	OSC	--	Oscillation terminal
21	A R R M	O	Reel control signal for reverse (Deck A)	53	GND	--	GND
22	A R C M	O	Cam control signal for reverse (Deck A)	54	DCS OUT	O	Compulink output
23	A F C M	O	Cam control signal for forward (Deck A)	55	DCS IN	I	Compulink input
24	NR REC	O	It is "H" when recording with NR on	56	REC MUTE	O	Recording mute control
25	A MUTE	O	It is "H" when deck A is not playing	57	NR OFF	O	NR on/off control
26	B MUTE	O	It is "H" when deck B is not playing	58	BIAS	O	Bias on/off control
27	PLAY MU	O	Deck mute	59	REV MODE	O	Indication control for reverse mode
28	CAP CONT	O	Capstan on/off control	60	REC LED	O	Indication control for record
29	REC	O	It is "H" when recording	61	BREV LED	O	Indication control for reverse playback
30	FADE CON	O	It is "H" when recording with fade	62	BFWD LED	O	Indication control for forward playback
31	BEQ	O	It is "L" when CrO ₂ tape is in deck B	63	AREV LED	O	Indication control for reverse playback
32	+5V	--	Power supply	64	AFWD LED	O	Indication control for forward playback

■ AN7374K (IC201) : Dolby IC

1. Block Diagram

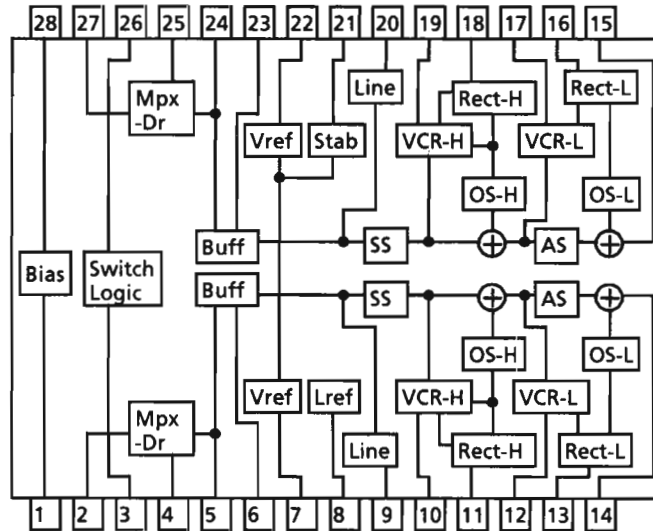

2. Pin function

Pin No	Symbol	Function	Pin No	Symbol	Function
1	GND	GND	15	REC OUT-L	Ch. B REC-OUT
2	REC IN-R	Ch. A REC-IN	16		Ch. B LLS control signal rectifier
3	OFF/B/C	C-type/B-type/OFF NR switch	17		Ch. B LLS control resistance
4	PB IN-R	Ch. A PB-IN	18		Ch. B HLS control signal rectifier
5		Ch. A MPX filter sriver output	19		Ch. B HLS control resistance
6		Ch. A Processor input	20	PB OUT-L	Ch. B LINE -OUT
7		Ch. A reference voltage output	21		Reference voltage input
8		Reference curent generator	22		Ch. B reference voltage output
9	PB OUT-R	Ch. A LINE -OUT	23		Ch. B Processor input
10		Ch. A HLS control resistance	24		Ch. B MPX filter sriver output
11		Ch. A HLS control signal rectifier	25	PB IN-L	Ch. B PB-IN
12		Ch. A LLS control resistance	26	PB/REC	PB/REC/PBmpx Mode switch
13		Ch. A LLS control signal rectifier	27	REC IN-L	Ch. B REC-IN
14	REC OUT-R	Ch. A REC-OUT	28	Vcc	Vcc

■ μ PC1297CA (IC341) : Dolby HX PRO System IC

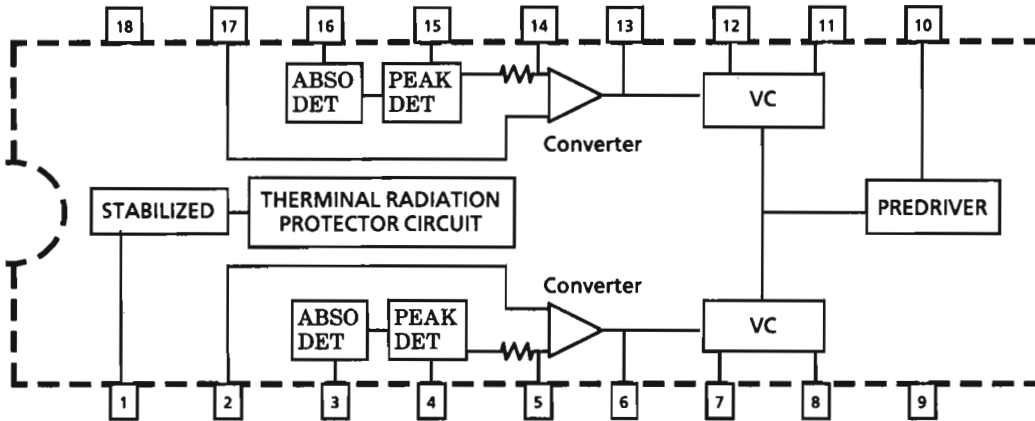

■ LB1641 (IC204~207) : DC Motor Driver

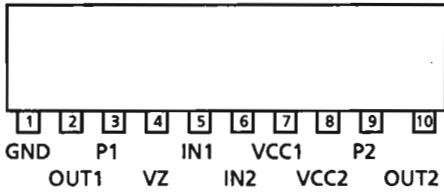

Input		Output		Mode
IN1	IN2	OUT1	OUT2	
0	0	0	0	Brake
1	0	1	0	CLOCKWISE
0	1	0	1	COUNTER-CLOCKWISE
1	1	0	0	Brake

∞ : Hi impedance

■ μ PC1330 HA (IC304) : HEAD SWITCH

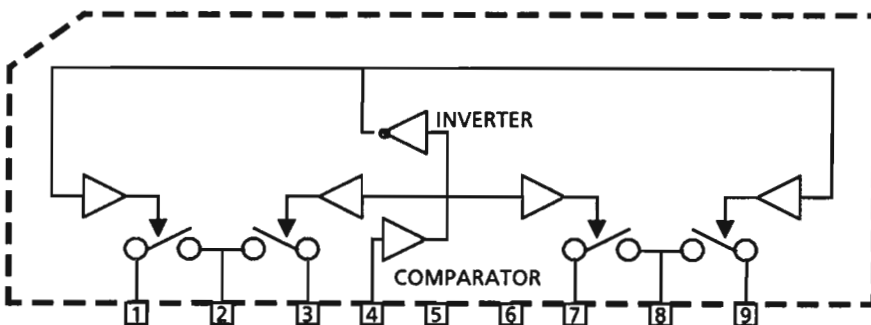

	4pin
PB	L
REC	H

Disassembly Procedures

(1) Removing the top cover

1. Remove 6 screws (A) and (B) fastening the rear and sides of the top cover to remove the cover.

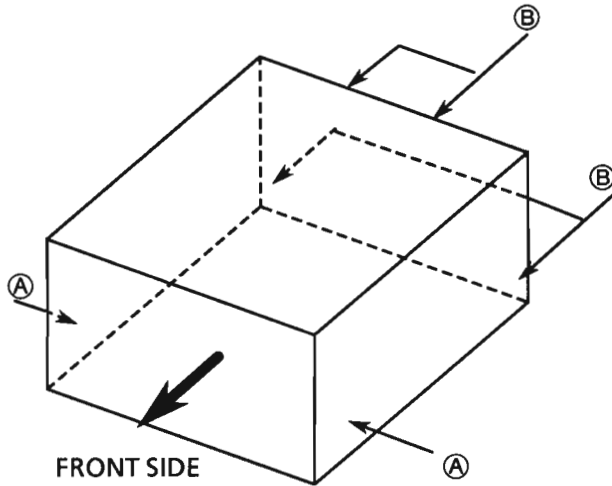

(2) Removing the Front panel assembly with same P.C.Bard

1. Remove the top cover.
3. Disconnect the connectors CN221.
4. Remove a screw (C) and 2 hooks fastening the assembly with chassis to remove the assembly.

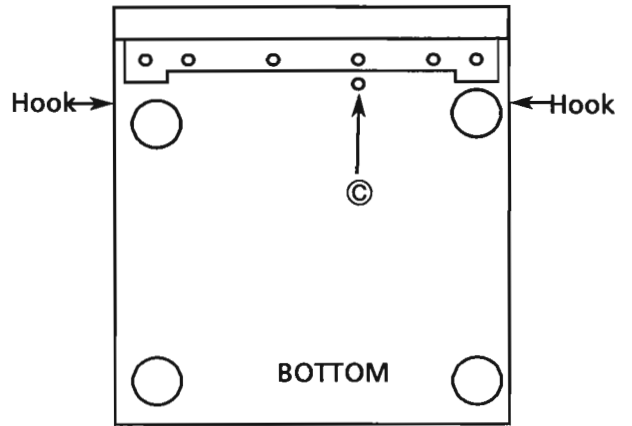

(3) Removing the Deck control circuit board (ENJ-097-2)

1. Remove the top cover .
2. Remove the 2 screws (E) fixing the circuit board.
3. Disconnect the connectors P292,293 and CN701.

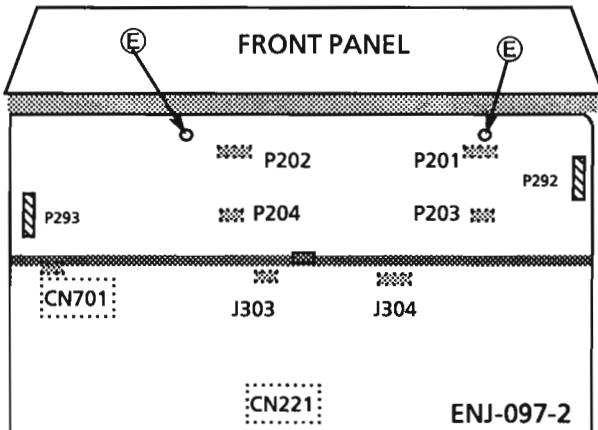

(4) Removing the mechanism assembly (ENJ-097-1)

1. Remove the top cover, frontpanel assembly and deck control circuit board.
2. Remove 8 screws (C) and (D) fastening mechanism assembly

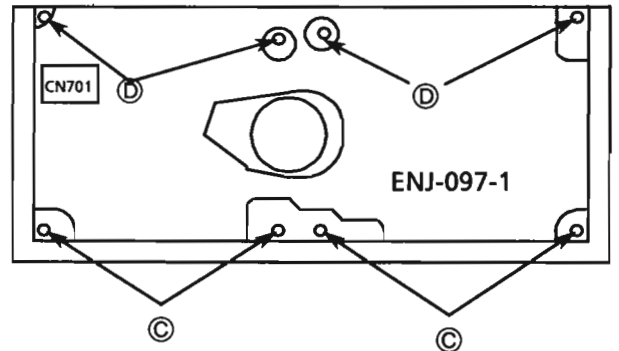

- (A) .. SD5G3008N (B) ... GB5G3008CC (C) ... SB5T3006Z (D) ... SB5F3008Z
 (E) .. SD5T2604Z

- (5) Removing the door lock plate assembly
1. Remove the mechanism assembly.
 2. Remove the 2 screws (F) fixing the assembly.
 3. Open the cassette doors to remove the assembly.

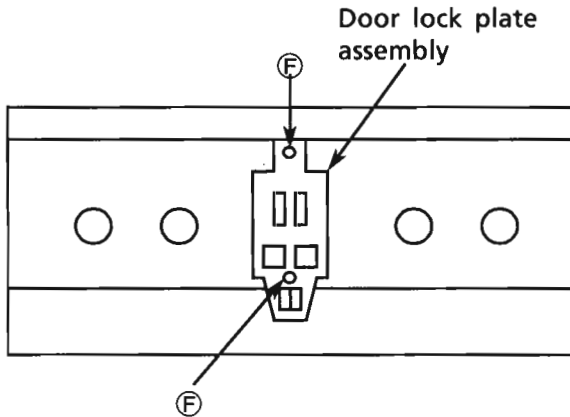

- (6) Removing the cassette lids
1. Push the eject button to open the cassette doors.
 2. Slide the lids up to remove them.

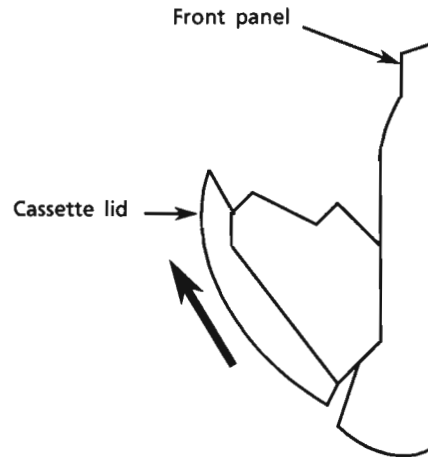

- (7) Removing the dumpers
1. Remove the mechanism assembly.
 2. Press the hook and release it to remove the dumper. (See an arrow)

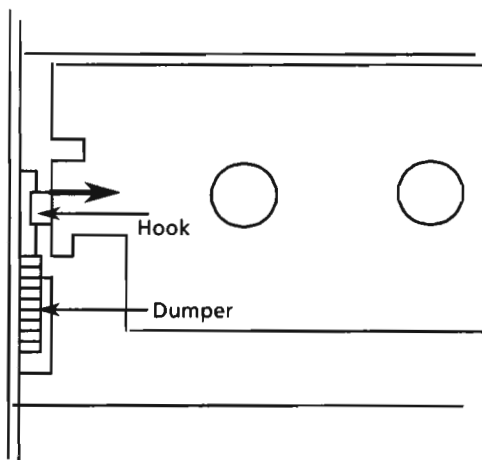

- (8) Removing the Cassette holder
1. Remove the mechanism assembly.
 2. Open the cassette door.
 3. Remove the spring.
 4. Remove the cassette holder.

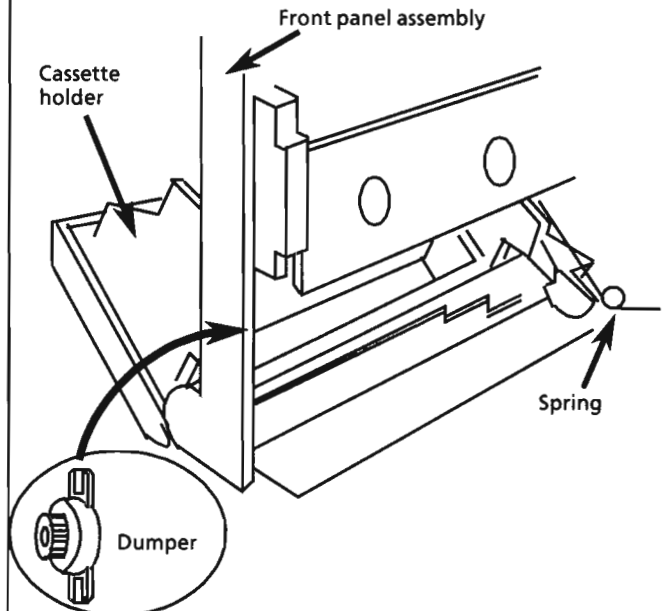

(F) .. SDSF2608Z

(9) Removing the Front SW circuit board (ENJ-097-3)

1. Remove the mechanism assembly and cassette holder.
2. Remove the 6 screws (M) to remove the holder bracket fixing the SW circuit board.
3. Remove 2 screws (F) to remove the circuit board.

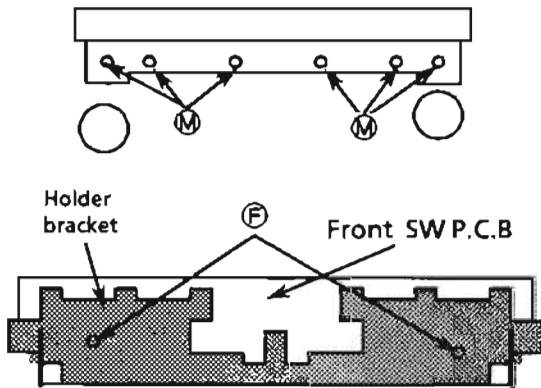

(10) Removing the deck audio circuit board (ENJ-097-1)

1. Remove the front panel assembly and Deck control circuit board (ENJ-097-2).
2. Disconnect CN331 and CN332.
3. Remove the 2 screws (C) to remove the circuit board. (Pay attention to the pawls.)

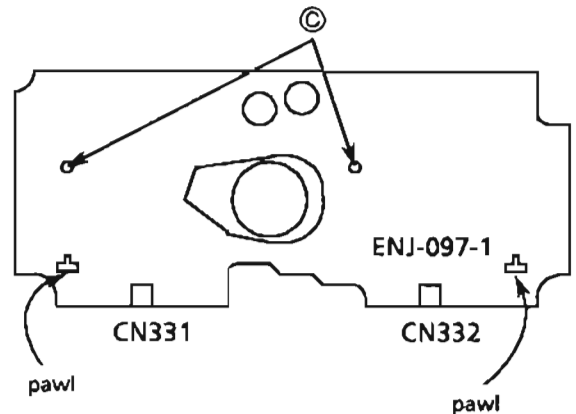

(11) Removing the capstan motor

1. Remove the deck audio circuit board.
2. Remove the 7 screws (F) fixing the bracket.
3. Release the hooks holding the bracket to remove the bracket with the capstan motor.
4. Remove the 2 screws fixing the motor to remove it.

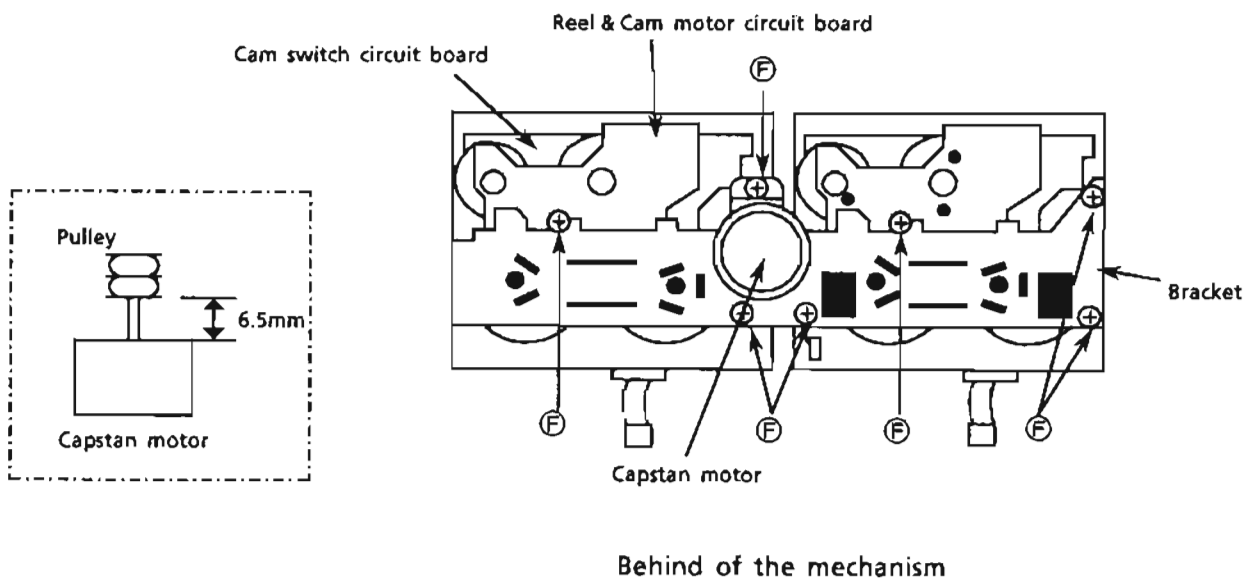

© .. SBST3006Z

(F) ... SDSF2608Z

(M) ... SDST3008CC

(12) Installing the head assembly

The direction of the head is changed with the head gear. When servicing, install the head gear according to the direction of the head.

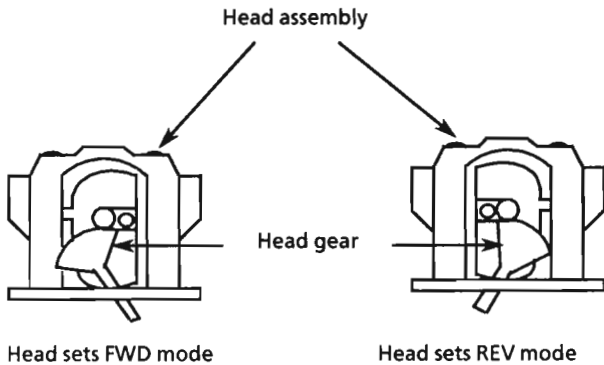

(13) Removing the pinchroller arm assembly

1. Remove the mechanism assembly.
2. Release the hook holding the assembly to remove it.

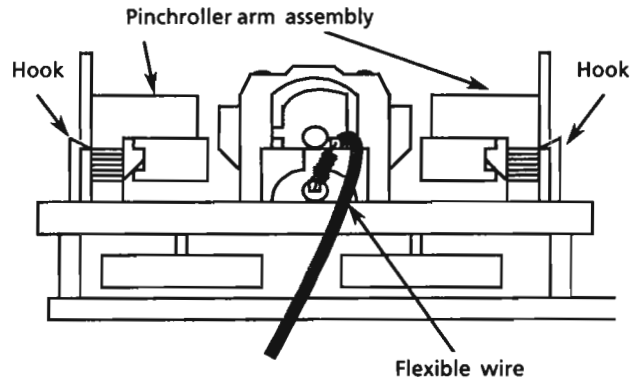

Bottom view of the mechanism

(14) Removing the Flywheels

1. Remove the deck audio circuit board.
2. Remove the 7 screws (E) and release the hooks holding the bracket to remove the bracket with the capstan motor.
3. Remove the flywheel.

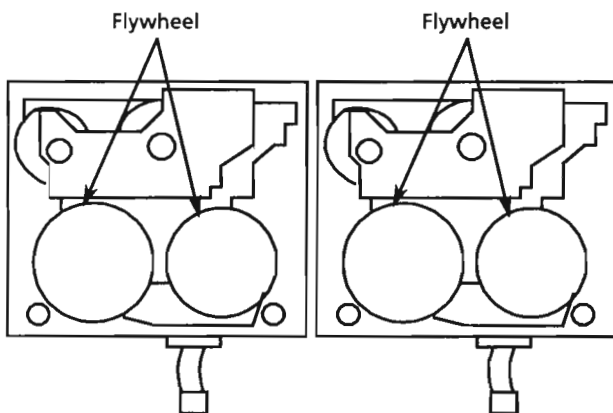

Behind of the mechanism

(15) How to install the belts

1. Install the belts as shown in the figure below.
When putting the belts, put the belt B first.
2. Install the bracket with the capstan motor to put the belts on the pulleys.

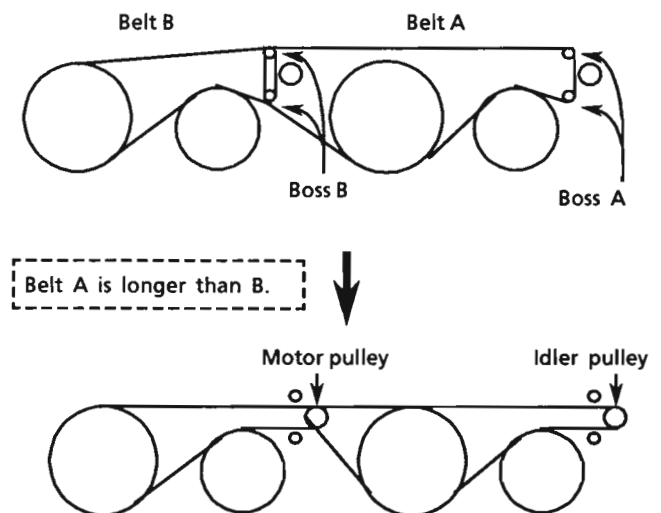

(16) Removing the reel & cam motor

1. Remove the flywheel.
2. Remove the screws \textcircled{K} and \textcircled{H} fixing the motors to remove the reel & cam motor circuit board.
3. Unsolder the motors to remove them.

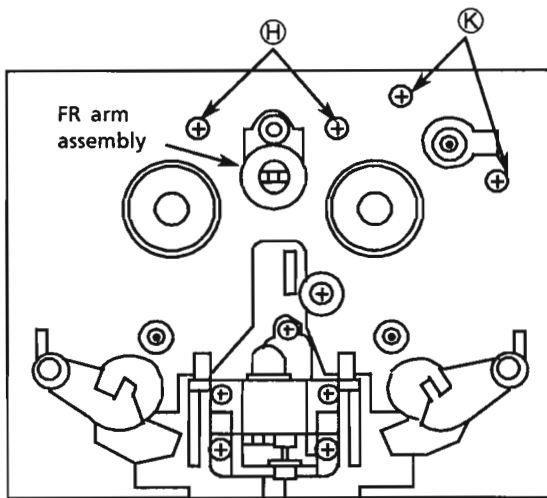

Front view of the mechanism

(17) Removing the cam switch circuit board

1. Remove the flywheel.
 2. Remove the reel & cam motor circuit board.
 3. Release the hook holding the cam switch circuit board and remove the screw to remove it.
- ※ When installing the cam switch circuit board, assemble the circuit board so that the part \textcircled{a} meets part \textcircled{b} .

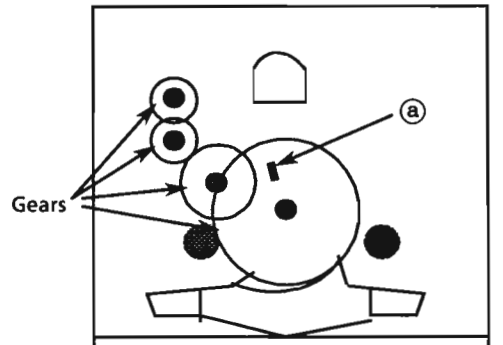

Cam switch C.B.

(18) Removing the head assembly

1. Remove the mechanism assembly. (Refer to Item 8)
2. Disconnect the connector CN331 or CN332 on the deck audio circuit board.
3. Remove the 3 screws \textcircled{L} fixing the head assembly to remove it.

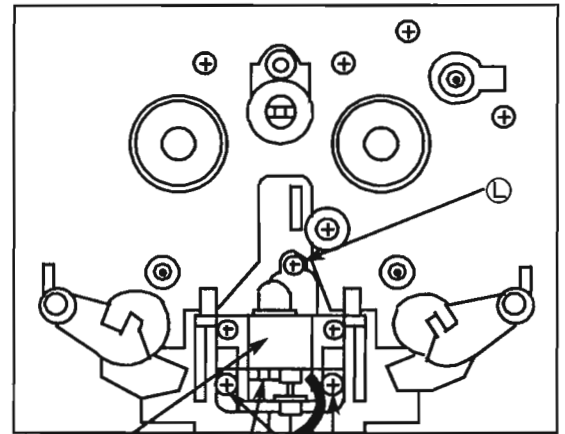

Front view of the mechanism

\textcircled{H} VKZ4705-001

\textcircled{K} VKZ4705-002

\textcircled{L} SDST2004Z

Adjustment Procedures (Cassette Deck)

1. Measuring instruments

- Audio frequency signal generator (0dbs output at the 600 ohm output terminal from 50Hz to 20KHz)
- Electronic voltmeter
- Frequency counter
- Wow & Flutter meter
- Distortion Meter with band pass filter
- Attenuator (600 ohm impedance)
- A resistor with 600Ω

Standard Tape

0dBs=0.775V

Tape No.	Frequency	Level (Wow & Fkutter)	Purpose
VTT-703L	10kHz	- 10dBs	Head azimuth , Frequency Response
VTT-712	3000Hz	0dBs 0.025%WRMS	Tape Speed , Wow & Flutter
VTT-724	1kHz	-4dBs	Standard Level
TMT-6447	—	—	Blunk Skip
TMT-6247 , TMT-6237	—	—	Music Scan
TMT-7046	—	—	Recording standard Normal : UR
AC-712	—	—	Recording standard METAL : MA
AC-513	—	—	Recording standard CrO ₂ : SA
TW-2111, TW-2121	—	—	Forward / reverse play torque measuring
TW-2231	—	—	Feed forward / rewind torque measuring
C-120 Tape	—	—	Confirming the tape running

2. Adjustment and repairing the mechanism

Item	Adjustment method	Standard value	Remarks
Head azimuth	<p>Deck A</p> <ol style="list-style-type: none"> 1. Connect an electronic voltmeter to the DOLBY TP (figure 3) to playback VTT-703L. 2. Adjust screw (A) so that the indication of the voltmeter becomes maximum when PLAY (▶) is pressed. 3. Adjust screw (B) so that the indication of the voltmeter becomes maximum when PLAY (◀) is pressed. <p>Deck B</p> <ol style="list-style-type: none"> 4. Adjust screw (C) so that the indication of the voltmeter becomes maximum when PLAY (▶) is pressed. 5. Adjust screw (D) so that the indication of the voltmeter becomes maximum when PLAY (◀) is pressed. 6. After making the adjustment, apply screw lock to prevent screws (A), (B), (C) and (D) coming loose. 	Maximum	<ol style="list-style-type: none"> 1. Refer to figure 1. 2. When the specified characteristic cannot be obtained because of head wear, excessive magnetization, etc., replace the head assembly and adjust the head azimuth. Also, perform the electric adjustment. 3. When there is the difference of more than 3 ~ 4 dB between left and right output levels, replace the head assembly to avoid complaints.
Playback torque	1. Measure the torque in the playback mode by the torqu meter.	26 ~ 62 g-cm	When the standard torque cannot be obtained, replace the FR arm assembly or motor.
Fast forward torque	1. Measure the torque in the fast forward mode by the torqu meter.	80 ~ 170 g-cm	When the standard torque cannot be obtained, replace the FR arm assembly or motor.
Rewind torque	1. Measure the torque in the rewind mode by the torqu meter.	80 ~ 170 g-cm	When the standard torque cannot be obtained, replace the FR arm assembly or motor.
Wow & flutter	<ol style="list-style-type: none"> 1. Connect the wow & flutter meter to the DOLBY TP (figure 3) and play back VTT-712. 2. Its reading should be within 0.2% (WTD). 	—	As a complaint may occur if the wow & flutter fluctuates by 0.1% even though it is allowed in the standard, repairing is required.

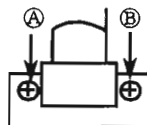

Deck A

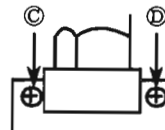

Deck B

Figure 1

3. Electrical Adjustments (Make the following adjustments after adjusting the head azimuth.)

In principle, the adjustments should be made in the following sequence.

Set the NR switch to OFF and the BEAT CUT switch to "1".

Adjustments marked with an asterisk (*) should always be made after the head is replaced

0dBs=0.775V.

Item	Adjustment Method	Adjustment Location	Standard Value	Remarks
Tape Speed	1. Connect a frequency counter to the DOLBY TP (figure 3) and play back VTT-712 . 2. Normal speed Adjustment 1) Mechanism B Play back deck B to adjust the semi-fixed resistor VR201 on ENJ - 086 - 2. 2) Mechanism A Play back deck A to confirm that the difference between deck A and deck B is within $\pm 51\text{Hz}$.	VR201 Check	3,000 Hz $\pm 10\text{Hz}$	1) Adjust the normal speed first, and perform the high speed adjustment.
* Standard level (Playback Level)	1. Connect an electronic voltmeter to the DOLBY TP (figure 3) . Play back VTT-724 (1 kHz : -4dBs) to adjust the semi - fixed resistors.	Deck A L: VR301 R: VR302 Deck B L: VR303 R: VR304	-5.5dBs (411mV) $\pm 1\text{dB}$	1) The playback level varies when the head is replaced so should be adjusted. Use an electronic voltmeter with an impedance of 100 k Ω or more.
* Playback Frequency Response	1. Connect an electronic voltmeter to the DOLBY TP (figure 3) . 2. Play VTT-703L (10kHz : -10dBs) and adjust semi-fixed resistors to obtain the standard values.	Deck A L: VR305 R: VR306 Deck B L: VR307 R: VR308	-11.5dBs (206mV) $\pm 3\text{dB}$	—
* Recording Bias Frequency	1. Connect a frequency counter to the BIAS TP (figure 3) , and perform a recording to adjust bias frequency .	L301	100 kHz ± 6 kHz	Set the BEAT CUT SWITCH to "1" .
* Record / Play Frequency Response (Bias current)	1. Supply 1kHz and 12.5kHz with 30mV signals to AUX (AX-F3000) terminals respectively to record them. 2. Connect an electronic voltmeter to the DOLBY TP (figure 3) to confirm the recorded values. 3. If the values are not satisfied , adjust the semi-fixed resistors and record the signal again to confirm the recorded values.	L: VR513 R: VR514	0 \pm 2 dB for 12.5 kHz with 1 kHz as the standard.	Refer to figure 2 below. 1) The recording and playback frequency response of a cassette deck are adjusted by adjusting the bias. 2) Perform the adjustment with normal tape and confirm that the values are within the range for metal tape.
* Adjustment HX PRO	1. Connect an electronic voltmeter to the R504(L), R503(R) at either end, and record the no signal Metal tape. 2. Adjust to the liast volues.	L501(L) L502(R)		

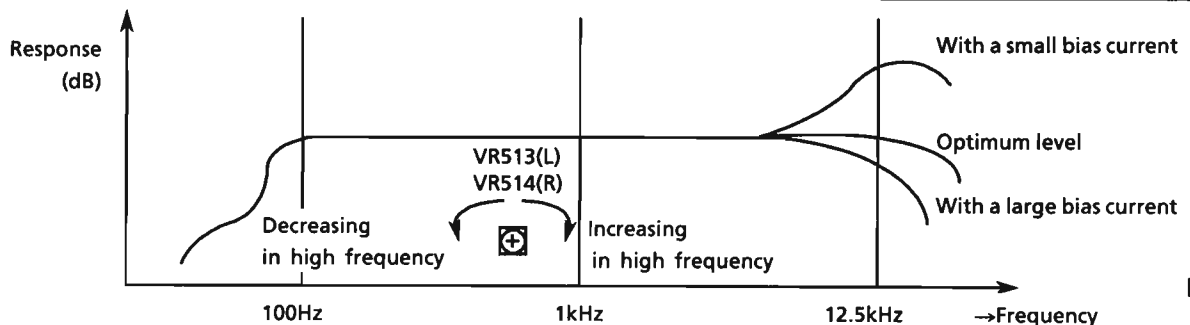

Figure 2

Item	Adjustment Method	Adjustment Location	Standard Value	Remarks
* Record / Playback Sensitivity	<ol style="list-style-type: none"> 1. Input a 1 kHz (-8.2dBs: 300mV) signal to PHONO / VCR terminals and record it on the left and right channels . 2. Connect an electronic voltmeter to the DOLBY TP (figure 3) to confirm the values . 3. If the values are not satisfied , adjust the semi-fixed resistors and record the signals again to confirm the values. 	L : VR311 R : VR312	-5.5dBs (411mV)	Adjust with normal tape and make sure that the left / right level difference is 1.0dB or less
* Erase ratio check	<ol style="list-style-type: none"> 1. Record a music source using metal tape. 2. Rewind and erase the recorded section. 3. Comfirm nothing can be heard. 	-	-	-
Auto-stop check	Make sure to operate AUTO STOP at the end of tape running and not to operate on the way of the playing.	-	-	-
Music Scan	<ol style="list-style-type: none"> 1. Make sure not to work the music scanning operation at the start of tape wind using TMT-6237. 2. Make sure to work the music scanning operation at the end of tape wind using TMT-6247. 	-	-	-

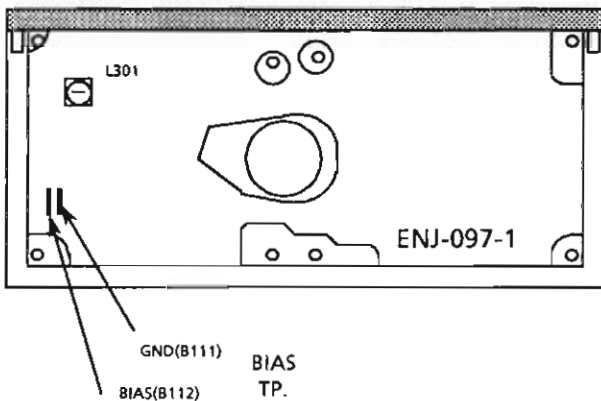

FIG.3

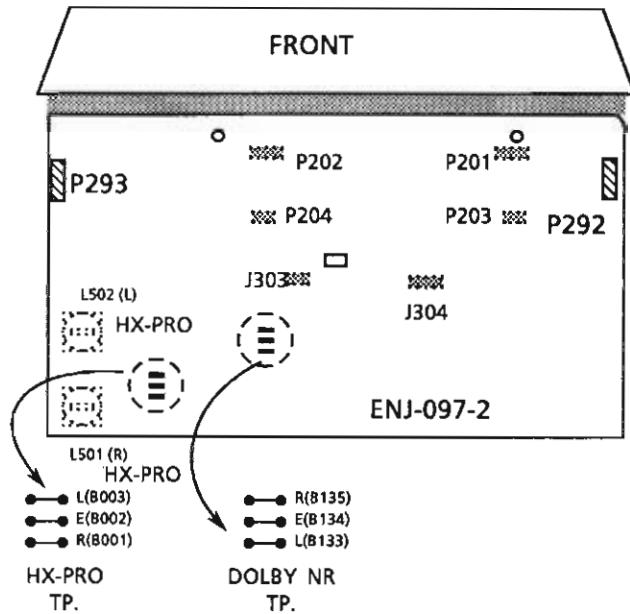

FIG.4

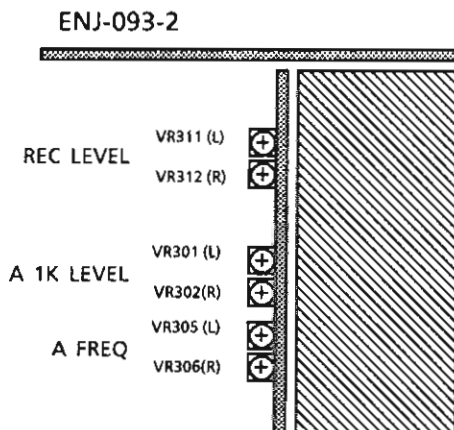

FIG.5 LEFT SIDE

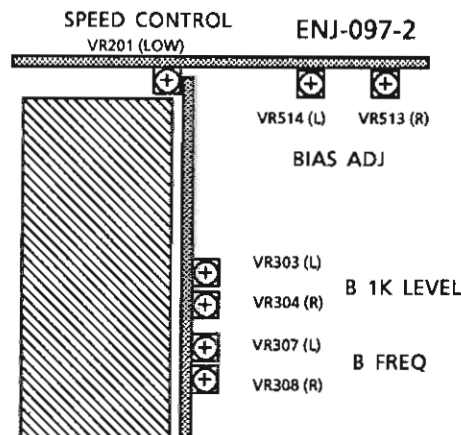
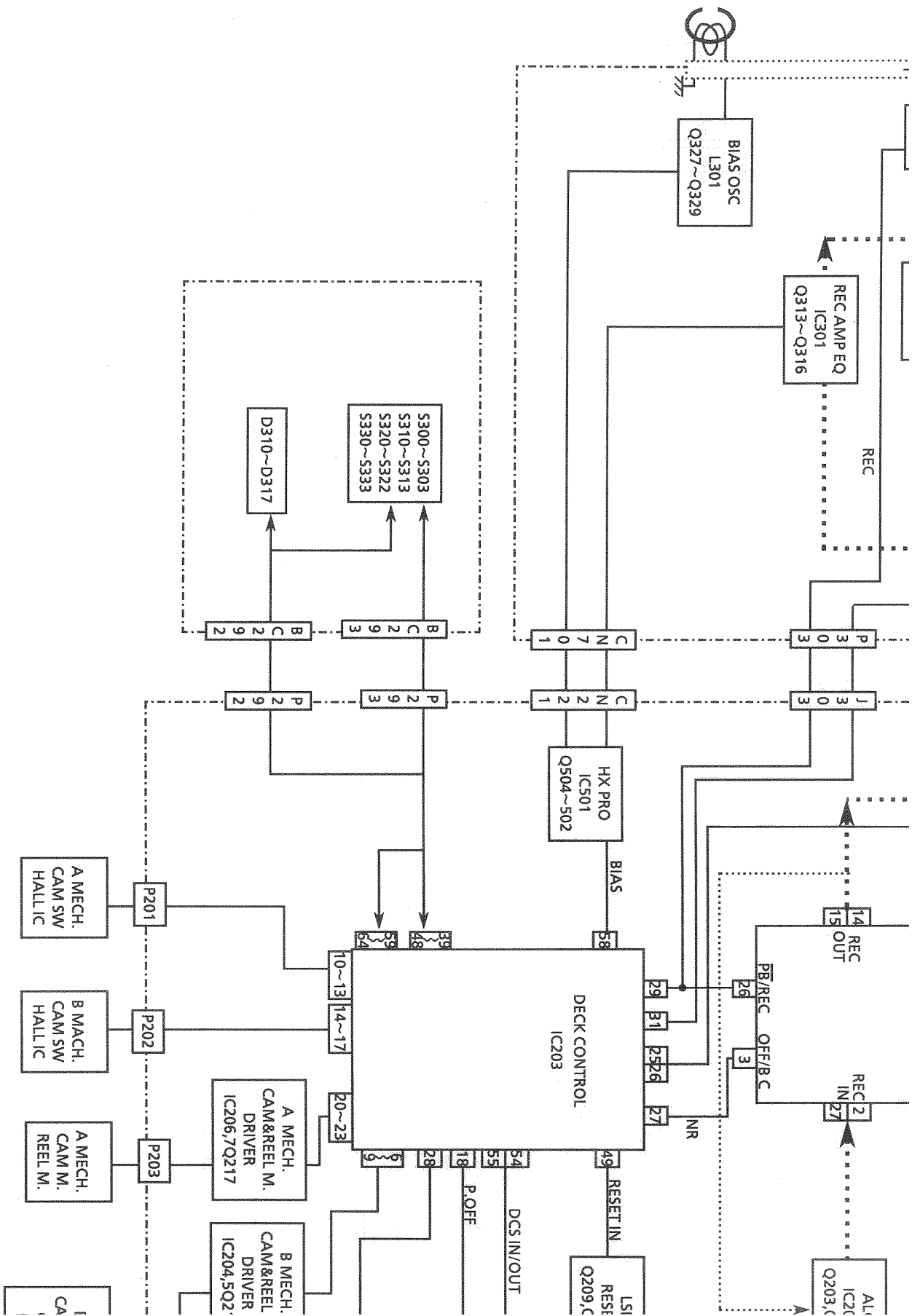
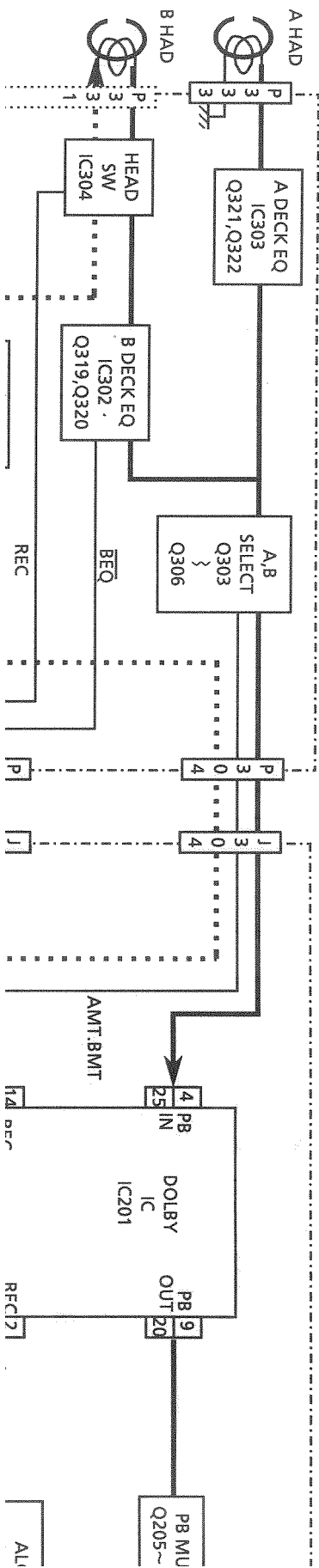
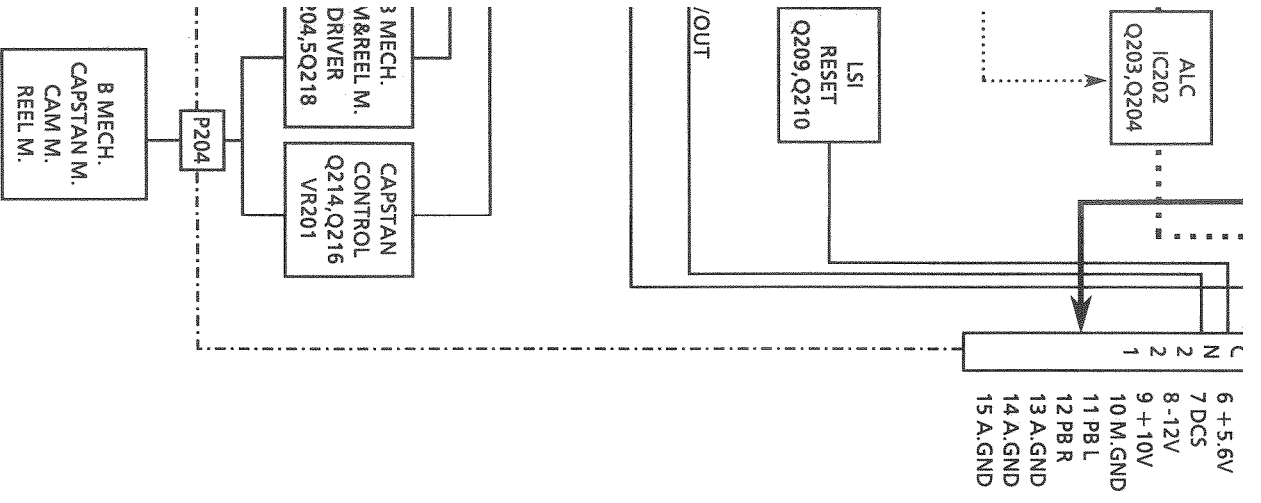

FIG.6 RIGHT SIDE



Block Diagram





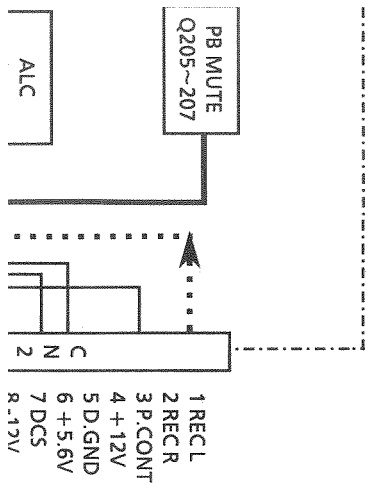

P4-14-a

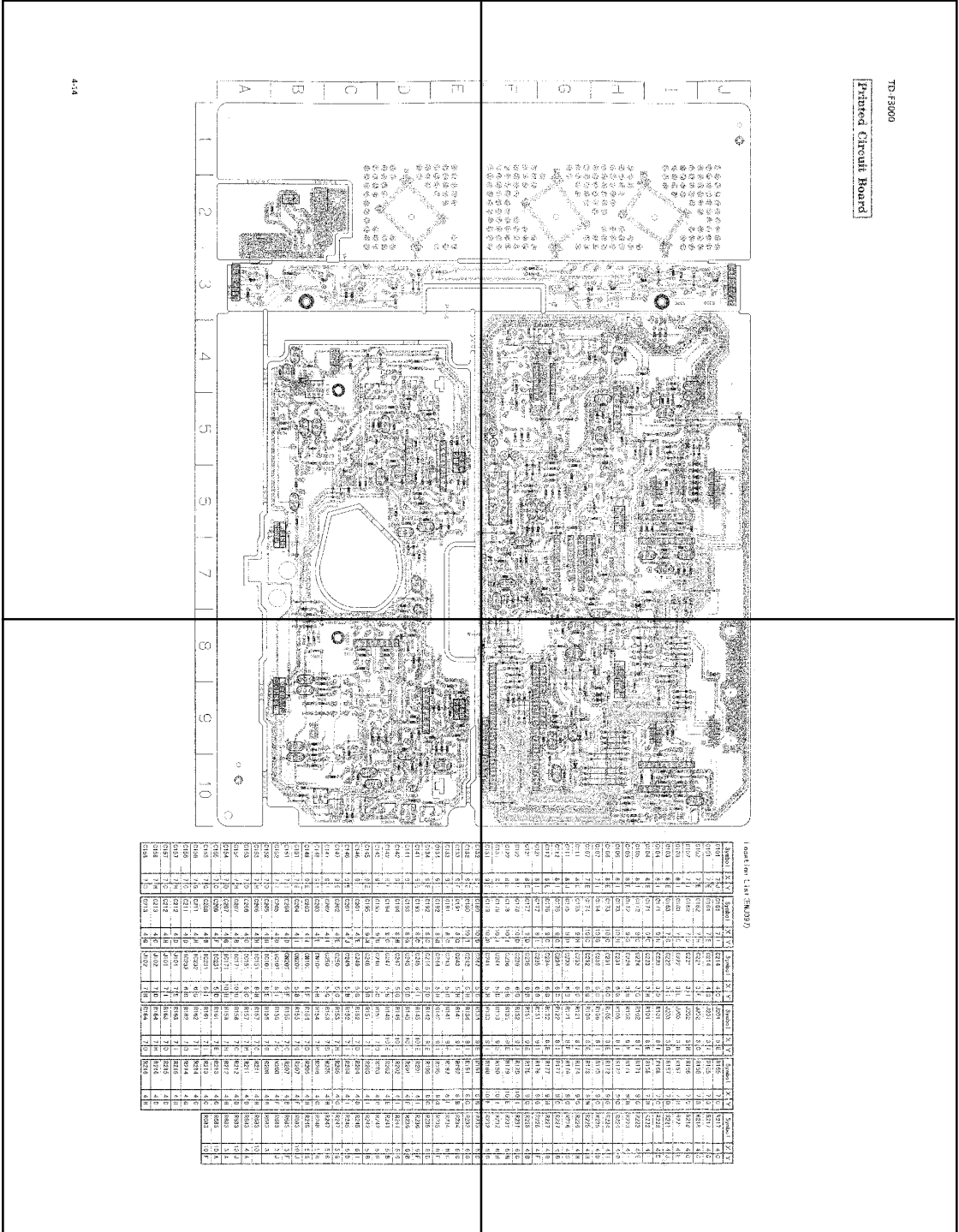

4-14

P4-14-b

P4-14-c

P4-14-d

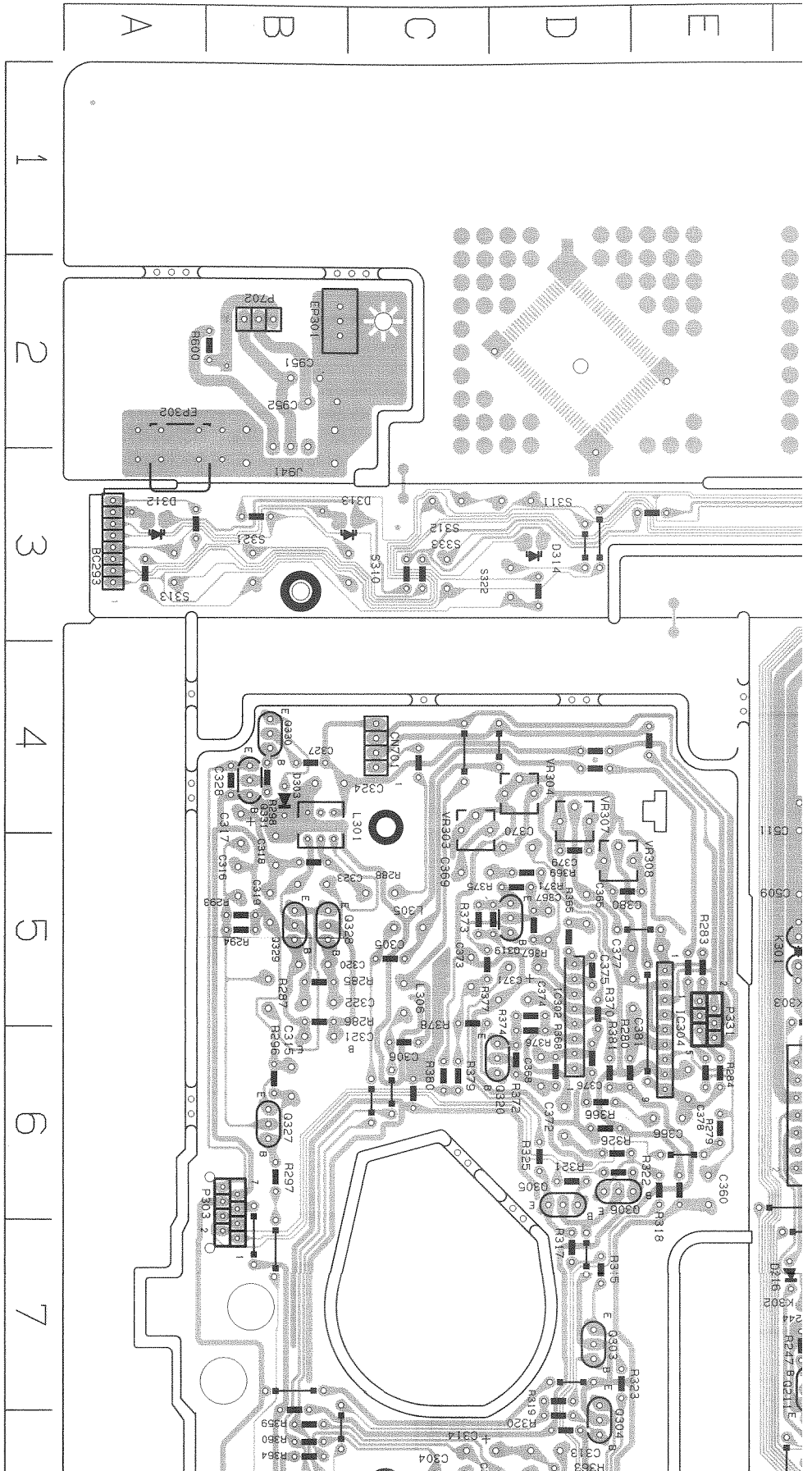

Printed Circuit Board

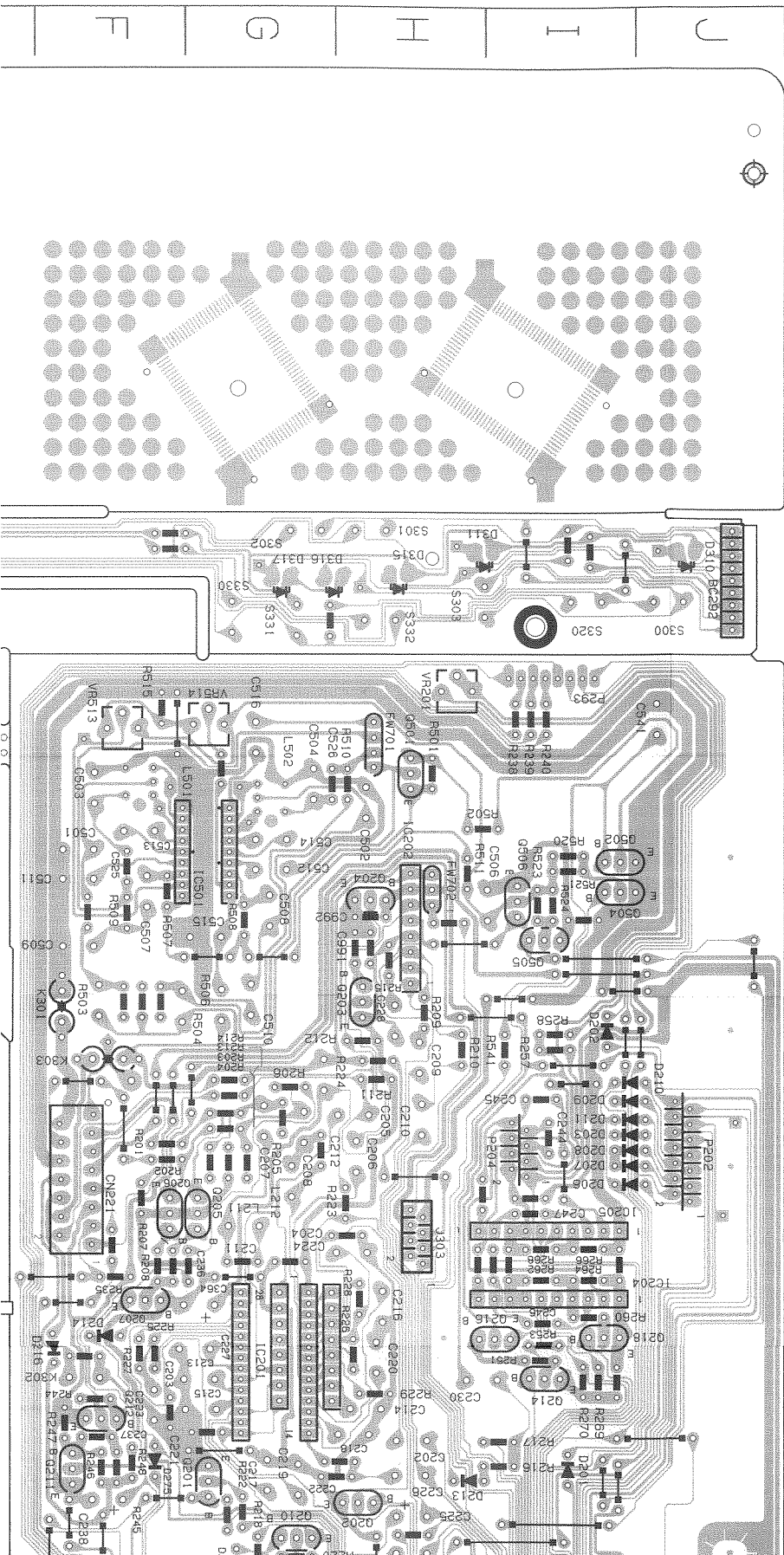

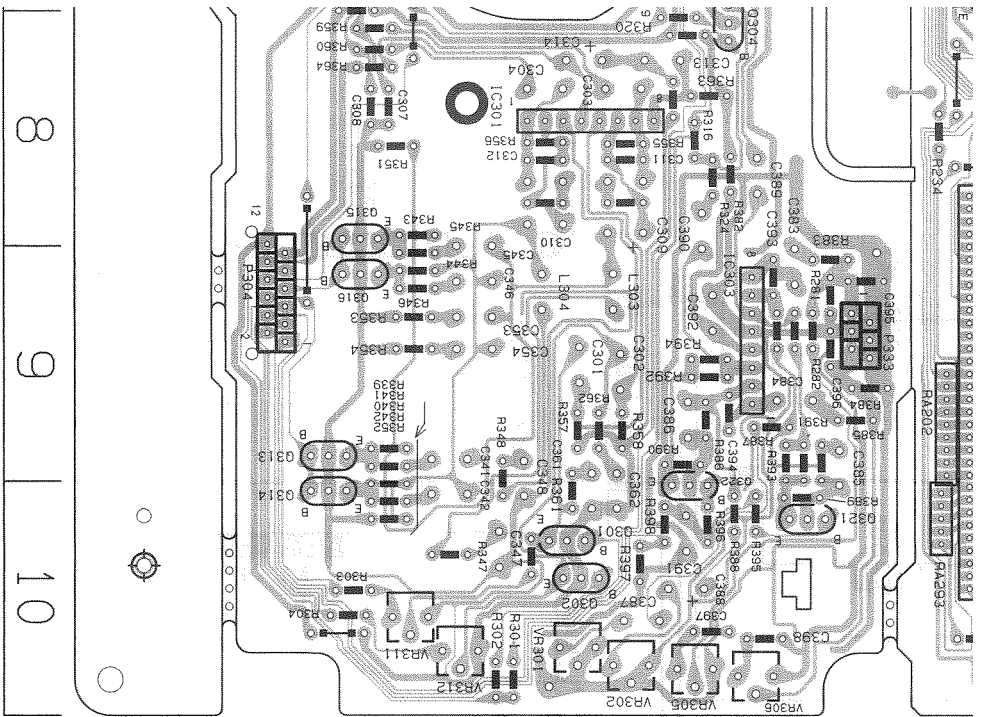

C131	9 E	C179	10 D	C241	5 H	R133	9 I	R180	10 E	R232	6 C
C132	9 I	C180	10 D	C242	5 D	R134	9 E	R191	8 B	R233	6 C
C132	9 E	C180	10 I	C242	5 H	R134	9 I	R191	8 G	R233	6 G
C133	9 E	C191	8 G	C243	5 H	R141	9 I	R192	8 B	R234	6 G
C133	9 I	C191	8 C	C243	5 D	R141	9 E	R192	8 F	R234	6 C
C134	9 I	C192	8 H	C244	5 H	R142	9 I	R195	9 G	R235	6 F
C134	9 E	C192	8 C	C244	5 D	R142	9 E	R195	9 C	R235	6 B
C141	9 E	C193	8 C	C245	6 I	R145	10 E	R201	4 I	R236	6 F
C141	9 I	C193	8 G	C245	6 D	R145	10 I	R201	4 E	R236	6 B
C142	9 I	C194	8 H	C247	5 G	R146	10 I	R202	4 I	R241	5 G
C142	9 E	C194	8 C	C247	5 B	R146	10 E	R202	4 E	R241	5 B
C145	9 I	C195	9 D	C248	5 C	R151	7 D	R203	4 D	R242	5 G
C145	9 E	C195	9 H	C248	5 G	R151	7 I	R203	4 I	R242	5 B
C146	9 I	C201	4 E	C249	5 B	R152	7 D	R204	4 D	R245	6 I
C146	9 E	C201	4 J	C249	5 B	R152	7 I	R204	4 I	R245	6 D
C147	9 E	C202	4 E	C250	5 C	R153	7 H	R205	4 C	R247	5 G
C147	9 I	C202	4 I	C250	5 G	R153	7 D	R205	4 H	R247	5 B
C148	9 I	C203	4 E	CN101	8 B	R154	7 H	R206	4 C	R248	5 B
C148	9 E	C203	4 I	CN101	8 F	R154	7 D	R206	4 H	R248	5 G
C151	7 E	C204	4 I	CN201	5 B	R155	7 G	R207	4 F	R663	10 J
C151	7 I	C204	4 D	CN201	5 F	R155	7 C	R207	4 B	R663	3 F
C152	7 I	C205	4 D	IG101	8 I	R156	7 C	R208	4 F	R663	3 J
C152	7 D	C205	4 H	IG101	8 E	R156	7 G	R208	4 B	R663	3
C153	7 H	C206	4 H	IG151	8 H	R157	7 C	R211	4 H	R663	10
C153	7 D	C206	4 C	IG151	8 C	R157	7 H	R211	4 D	R663	4 A
C154	7 H	C207	4 B	IG171	10 D	R158	7 C	R212	4 D	R663	10 J
C154	7 D	C207	4 G	IG171	10 H	R158	7 H	R212	4 H	R663	3 A
C155	7 C	C208	4 F	IG231	5 D	R161	7 E	R213	4 G	R663	10 A
C155	7 G	C208	4 B	IG231	5 I	R161	7 I	R213	4 C	R663	
C156	7 G	C211	4 H	IG232	6 G	R162	7 I	R214	4 C	R663	
C156	7 C	C211	4 D	IG232	6 C	R162	7 D	R214	4 G	R663	
C157	7 H	C212	4 D	J101	7 E	R163	7 I	R215	4 H	R663	
C157	7 C	C212	4 H	J101	7 I	R163	7 D	R215	4 D	R663	
C158	7 H	C213	4 C	J102	7 D	R164	7 H	R216	4 D	R663	
C158	7 C	C213	4 G	J102	7 H	R164	7 D	R216	4 H	R663	

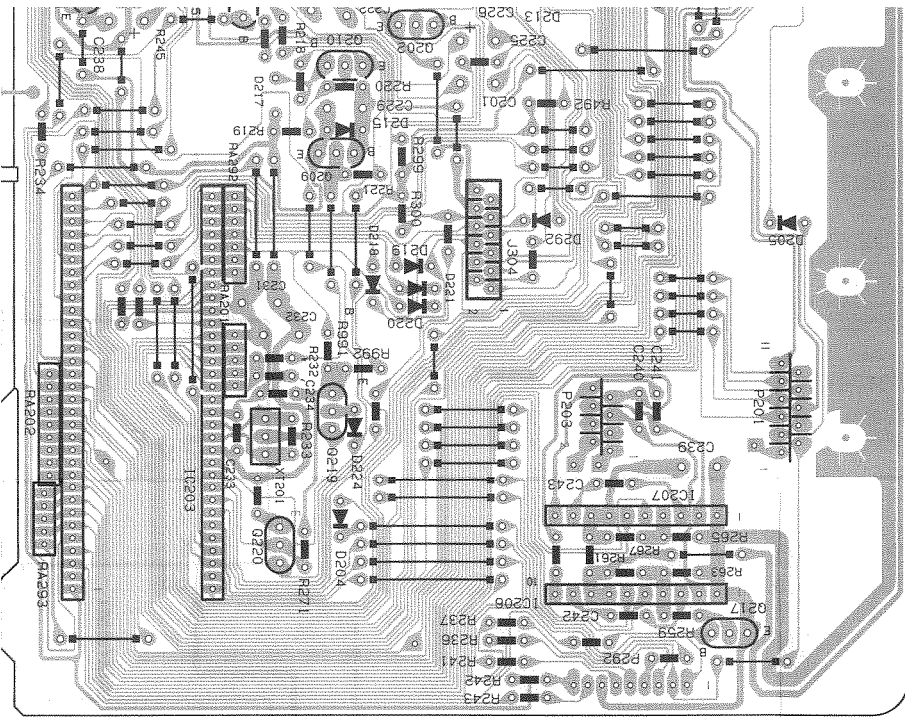

Location List (ENU097)

C101	7 J	C161	7 I	C214	4 C	J201	3 E	R165	7 C	R217	4 C
C101	7 E	C161	7 E	C214	4 G	J201	3 I	R165	7 G	R217	4 G
C102	7 E	C162	7 H	C221	3 E	J202	3 C	R166	7 G	R218	4 C
C102	7 I	C162	7 D	C221	3 I	J202	3 H	R166	7 C	R218	4 G
C103	8 I	C163	7 C	C222	3 E	J203	3 B	R167	7 H	R221	4 E
C103	8 E	C163	7 G	C222	3 I	J203	3 G	R167	7 D	R221	4 J
C104	8 I	C171	9 H	C223	3 D	R101	8 I	R168	7 C	R222	4 E
C104	8 E	C171	9 C	C223	3 H	R101	8 E	R168	7 H	R222	4 I
C105	8 I	C172	9 C	C224	3 G	R102	8 I	R171	9 C	R223	4 E
C105	8 E	C172	9 G	C224	3 B	R102	8 E	R171	9 H	R223	4 I
C106	8 I	C173	10 H	C231	6 G	R105	8 I	R172	9 C	R224	4 D
C106	8 E	C173	10 C	C231	6 C	R105	8 E	R172	9 G	R224	4 I
C107	7 I	C174	10 G	C232	6 C	R106	8 I	R173	9 C	R225	4 D
C107	7 E	C174	10 C	C232	6 G	R106	8 E	R173	9 H	R225	4 H
C111	8 E	C175	9 H	C233	6 C	R121	8 I	R174	9 C	R226	4 H
C111	8 J	C175	9 D	C233	6 G	R121	8 E	R174	9 G	R226	4 C
C112	8 I	C176	9 G	C234	6 C	R122	8 I	R177	9 C	R227	4 B
C112	8 E	C176	9 C	C234	6 G	R122	8 E	R177	9 H	R227	4 G
C121	8 I	C177	9 I	C235	6 G	R131	9 I	R178	9 G	R228	4 F
C121	8 E	C177	9 D	C235	6 B	R131	9 E	R178	9 C	R228	4 B
C122	8 I	C178	10 D	C236	6 G	R132	9 I	R179	10 I	R231	6 C
C122	8 E	C178	10 I	C236	6 B	R132	9 E	R179	10 E	R231	6 H
C131	9 I	C179	10 I	C241	5 D	R133	9 E	R180	10 I	R232	6 H
C131	9 E	C179	10 D	C241	5 H	R133	9 I	R180	10 E	R232	6 C
C132	9 I	C180	10 D	C242	5 D	R134	9 E	R191	8 B	R233	6 C

P4-15-a

P4-15-b

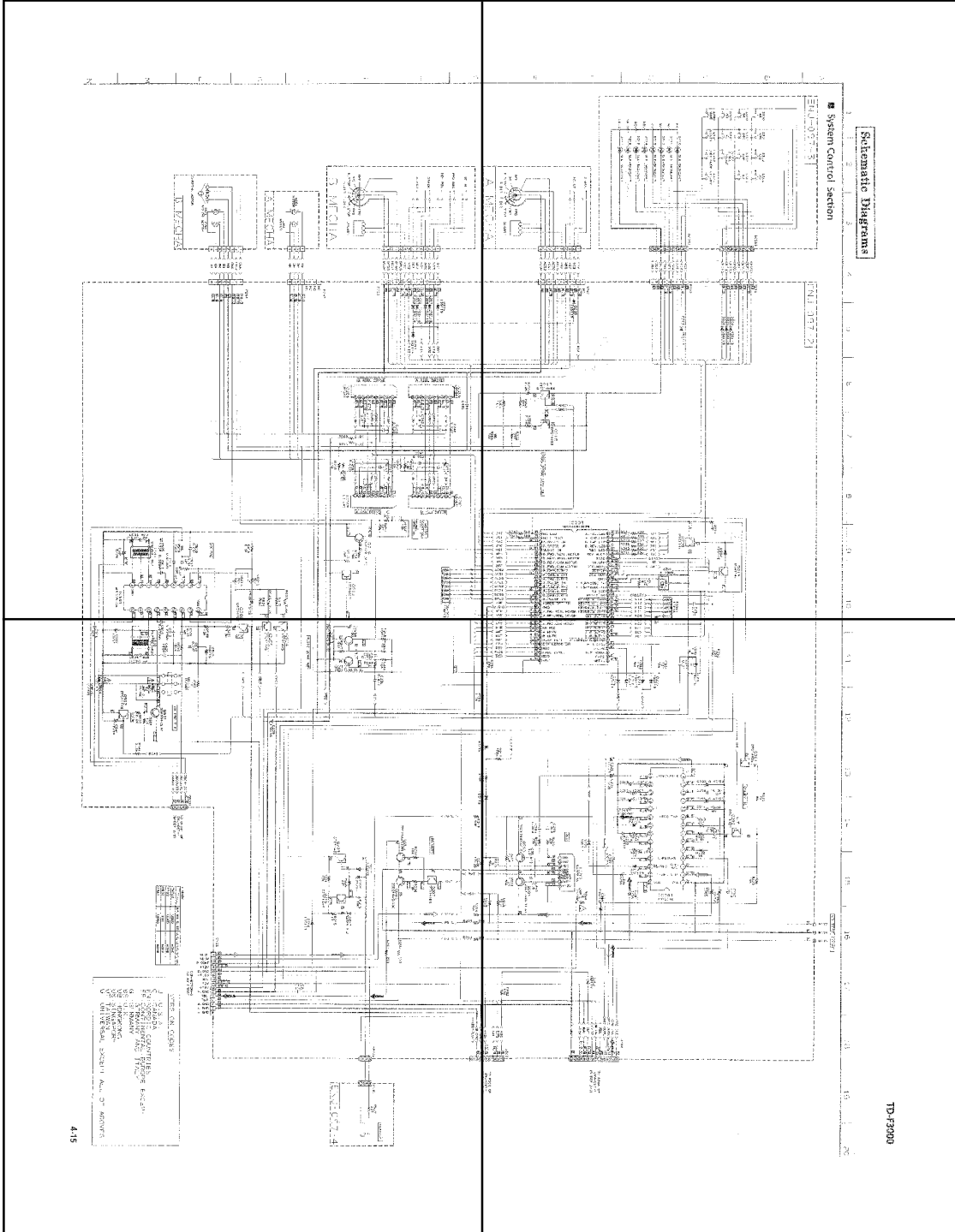

P4-15-c

P4-15-d

G
H
I
J
K
L
M
N
O

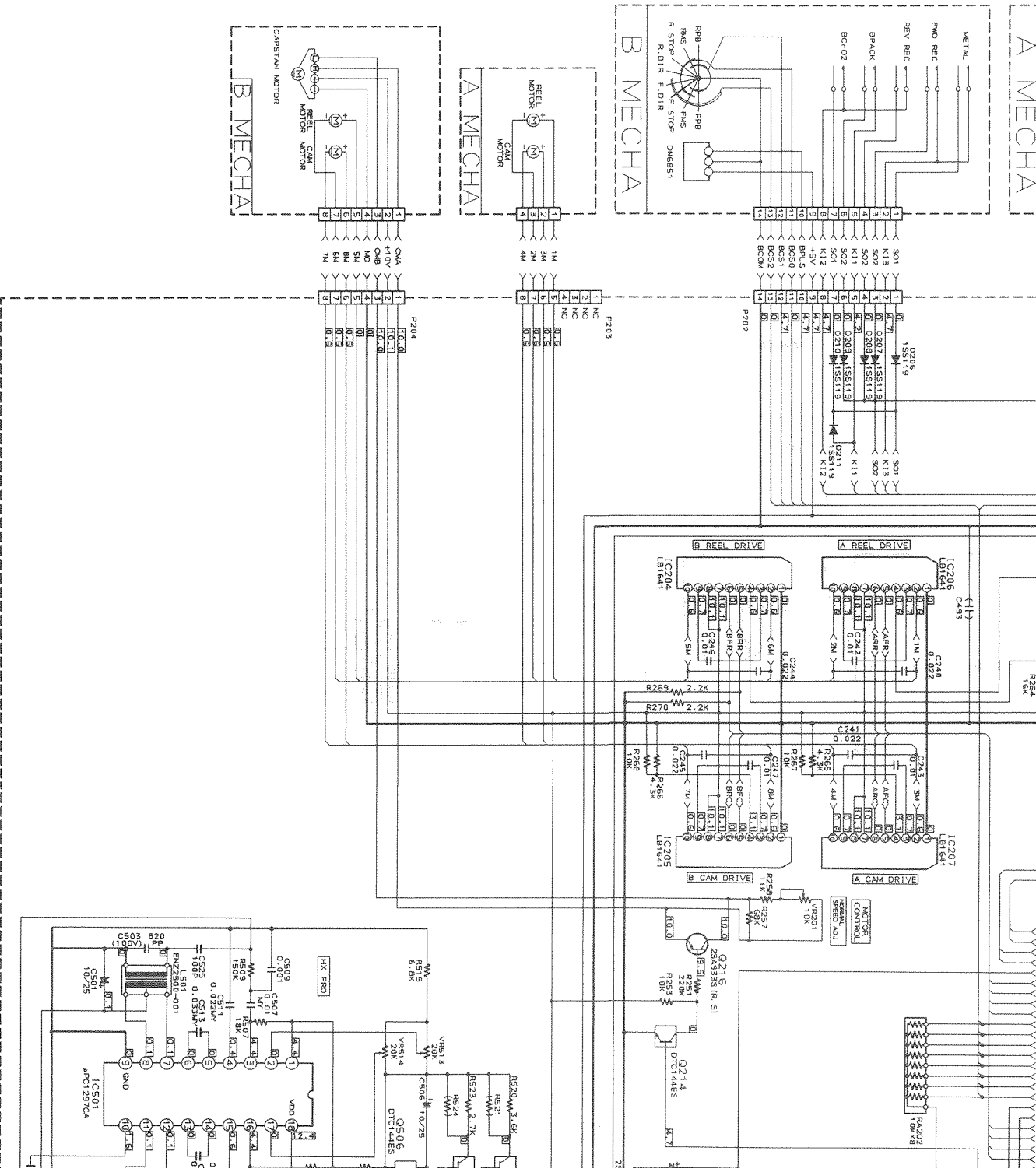

Schematic Diagrams

System Control Section

ENJ-097-3

ENJ-097-2

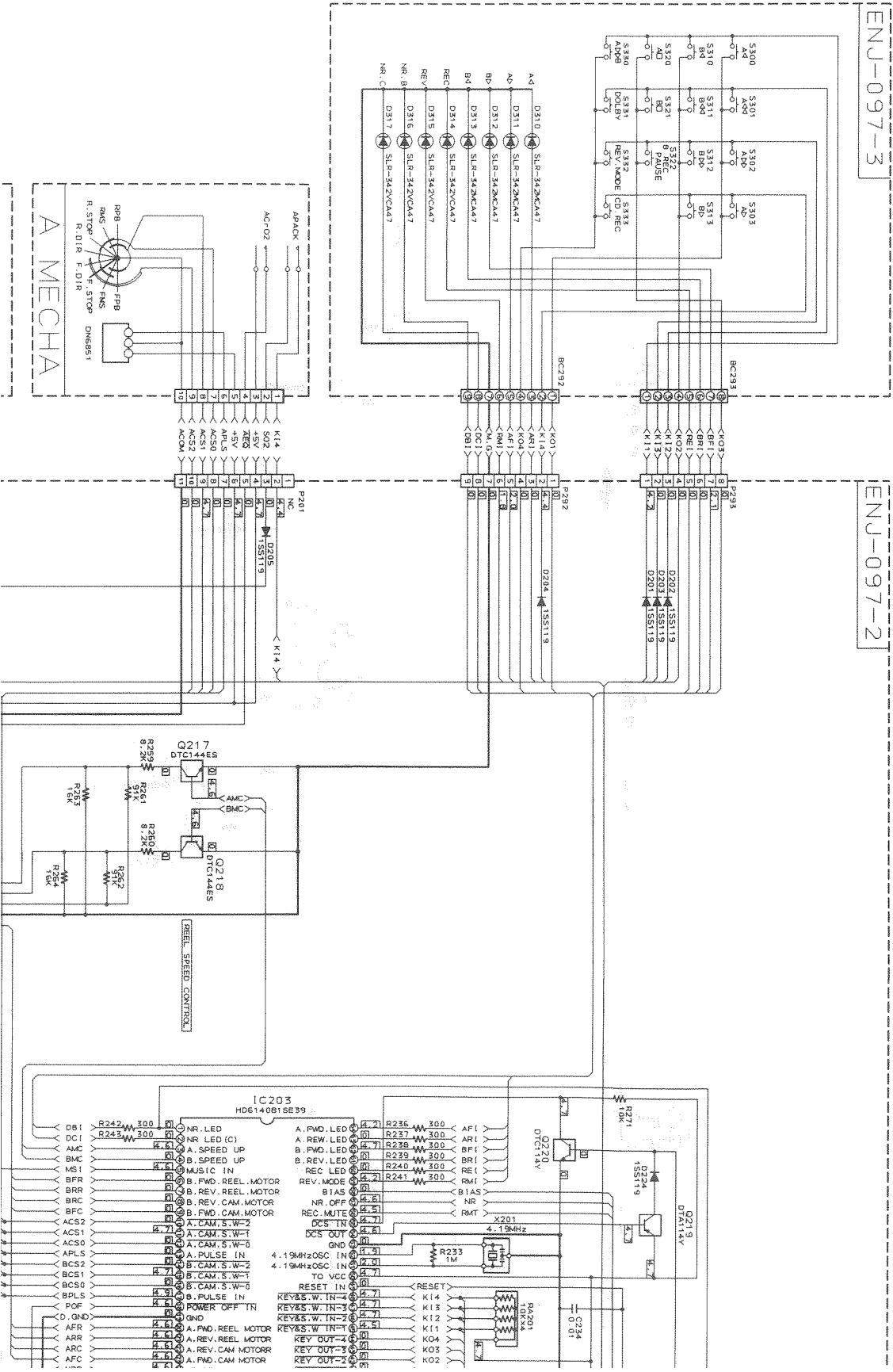

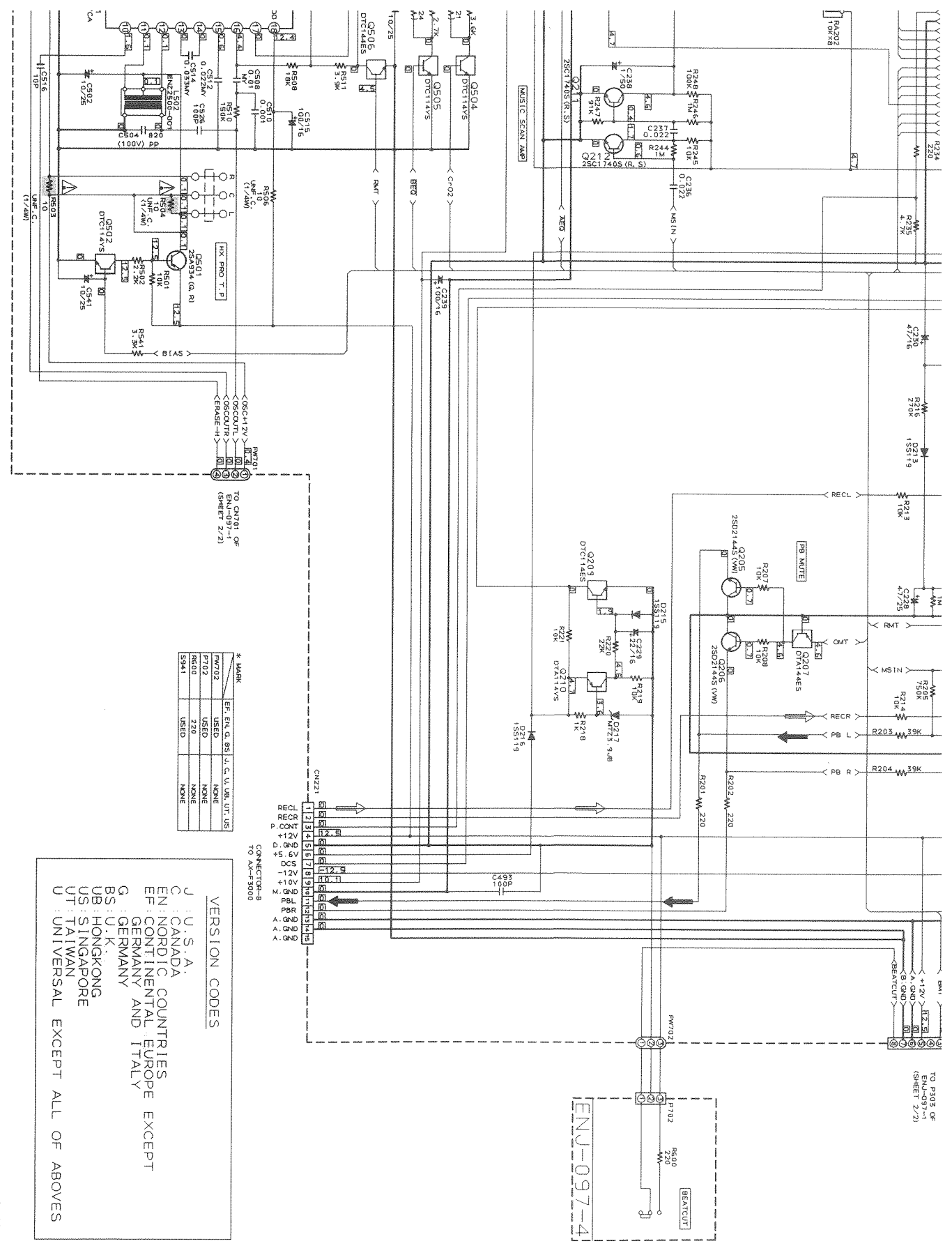

0 11 12 13 14 15 16 17 18 19 20

NR TEST POINT

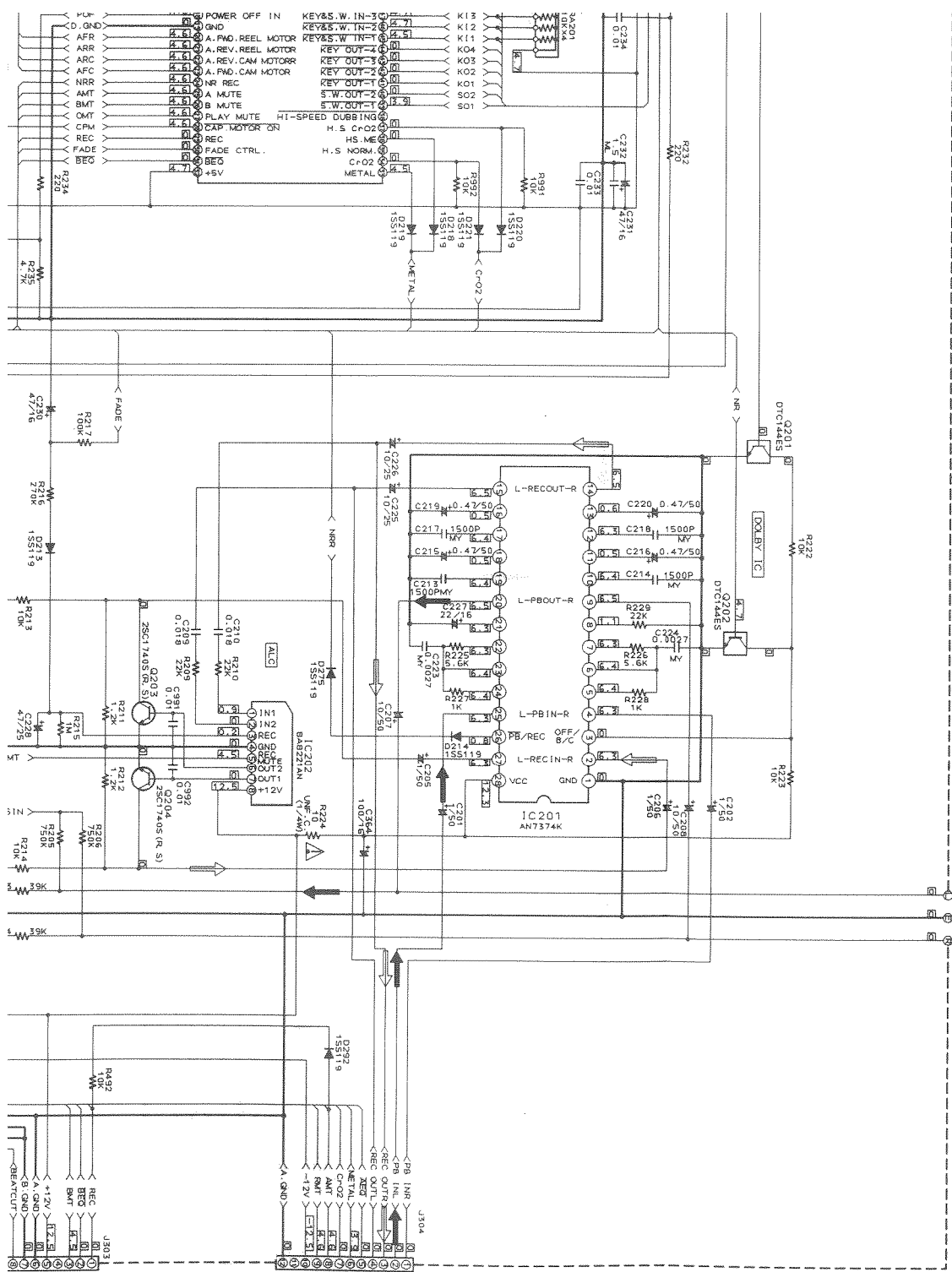

TO P304 OF
EN-057-1
(SHEET 2/2)

TO P302 OF
EN-057-1
(SHEET 2/2)

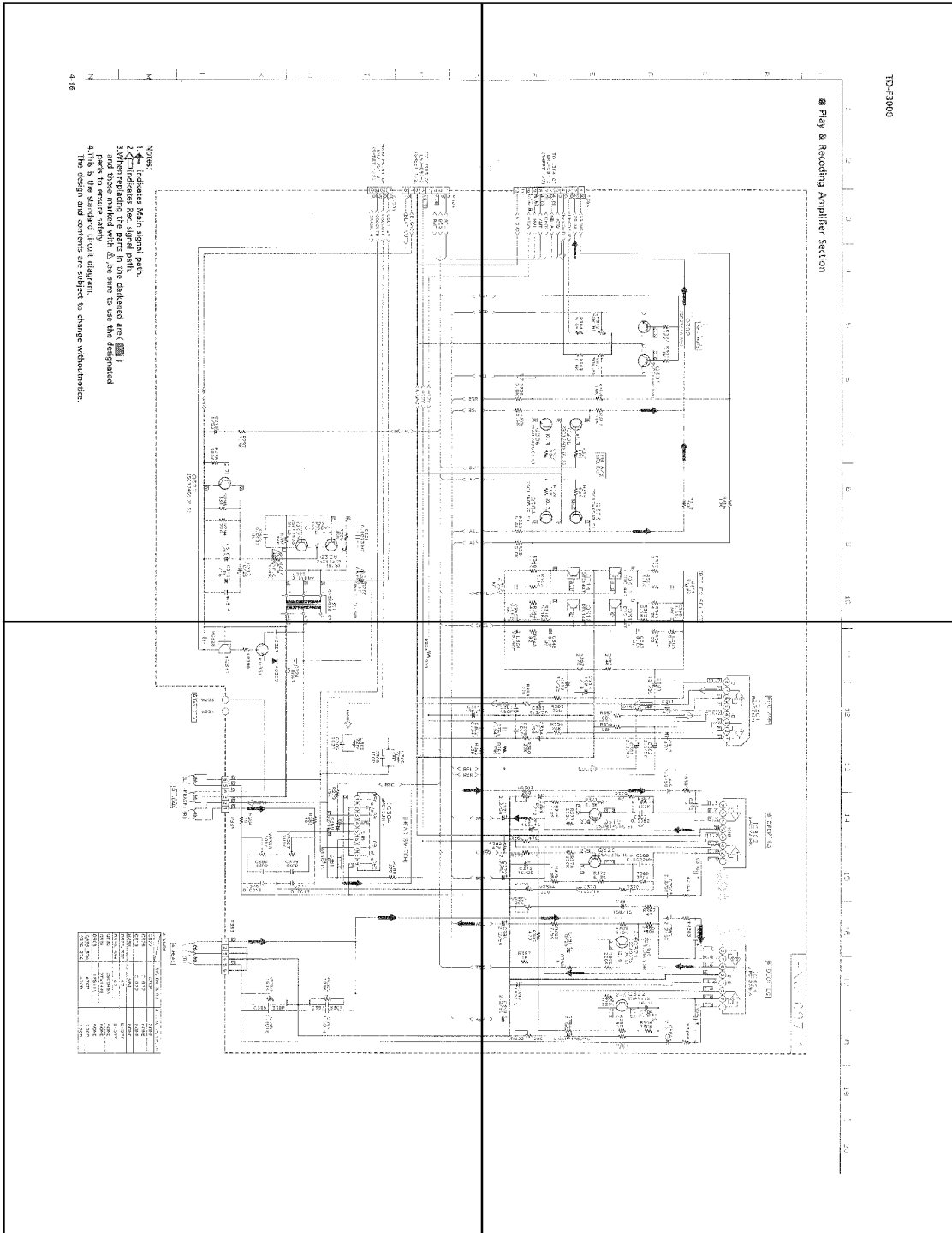

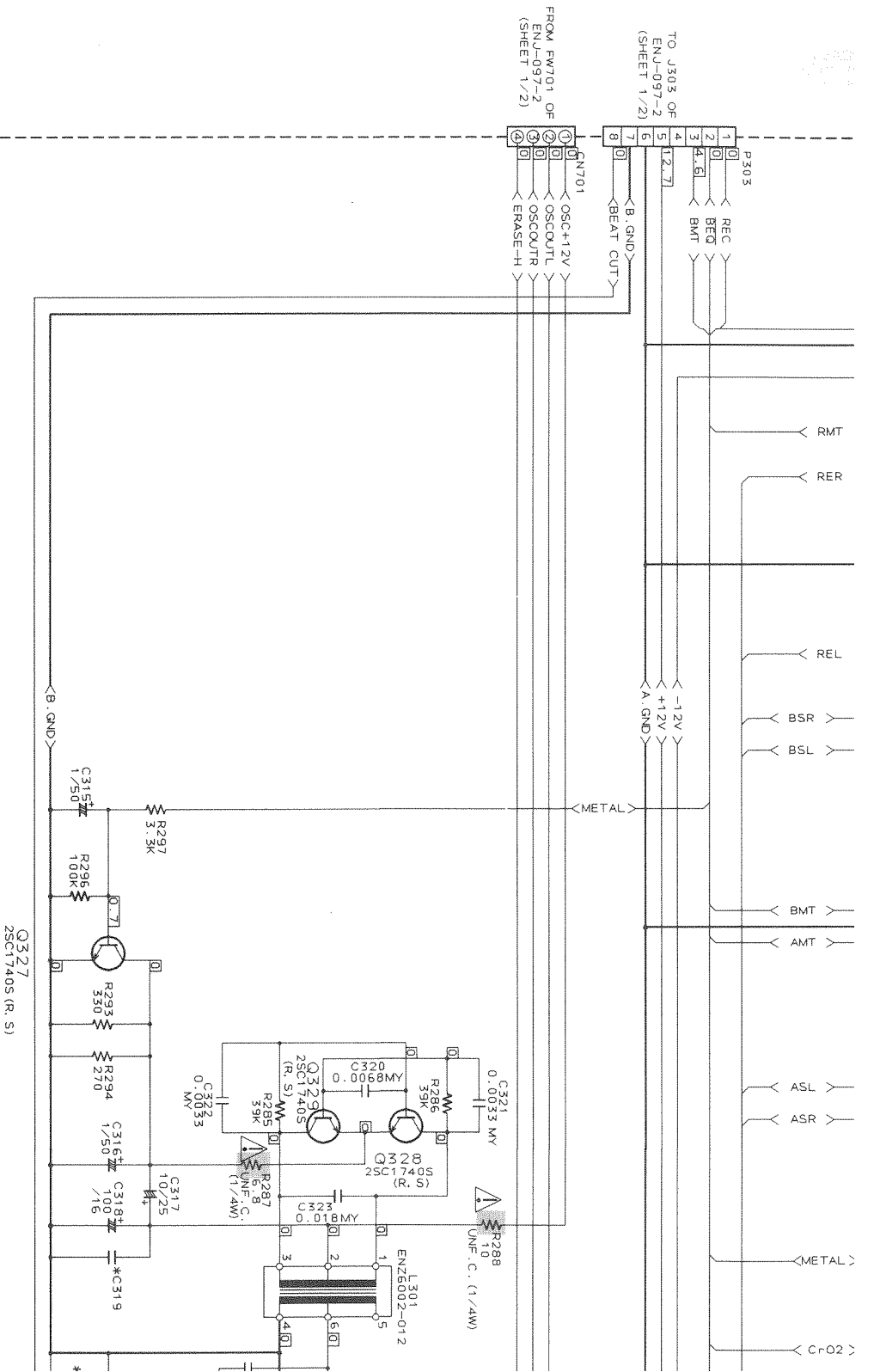

- Notes:
1. **↑** indicates Main signal path.
 2. **◀** indicates Rec. signal path.
 3. When replacing the parts in the darkened are (**█**) and those marked with **△**, be sure to use the designated parts to ensure safety.
 4. This is the standard circuit diagram. The design and contents are subject to change without notice.

■ Play & Recoding Amplifier Section

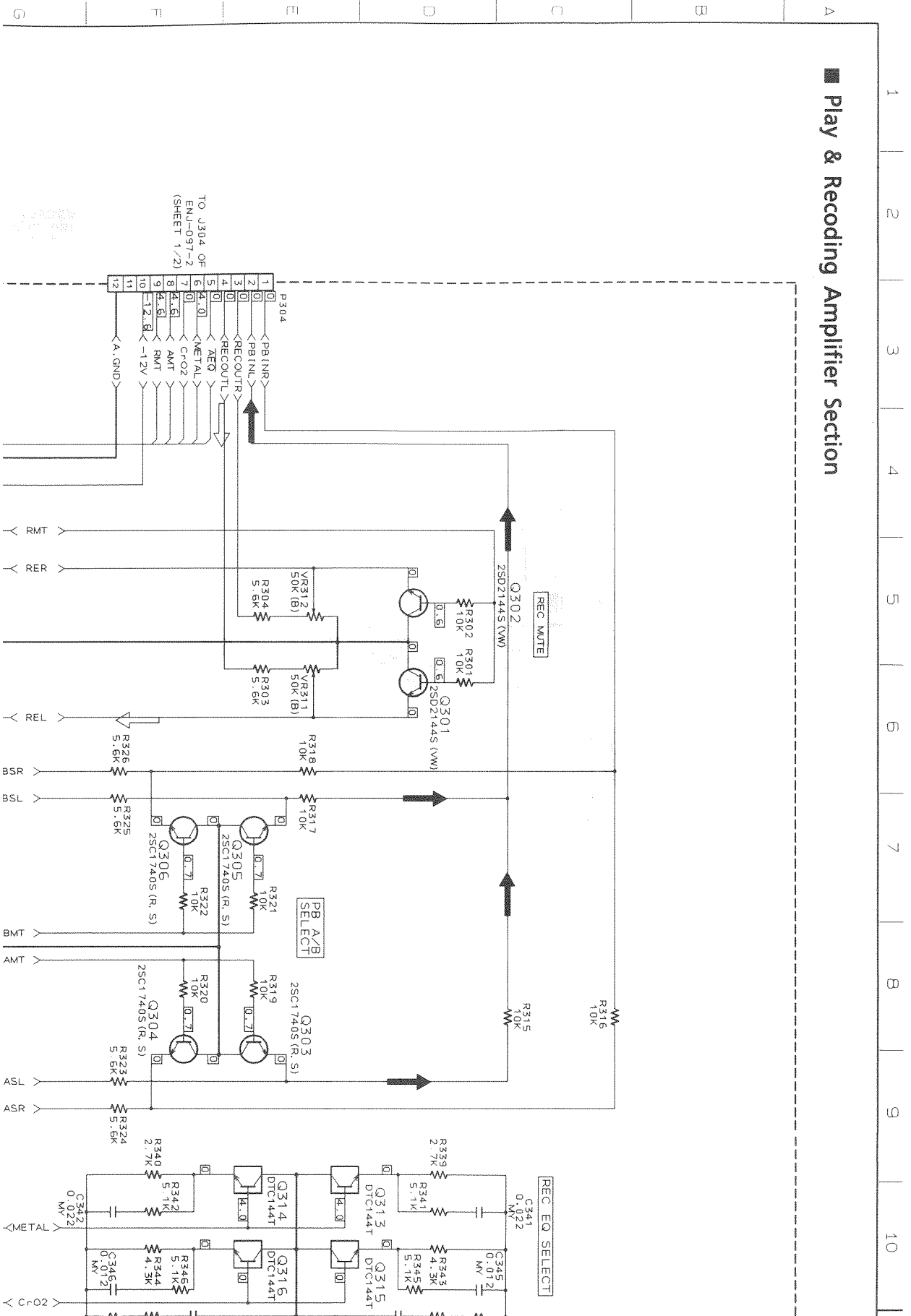

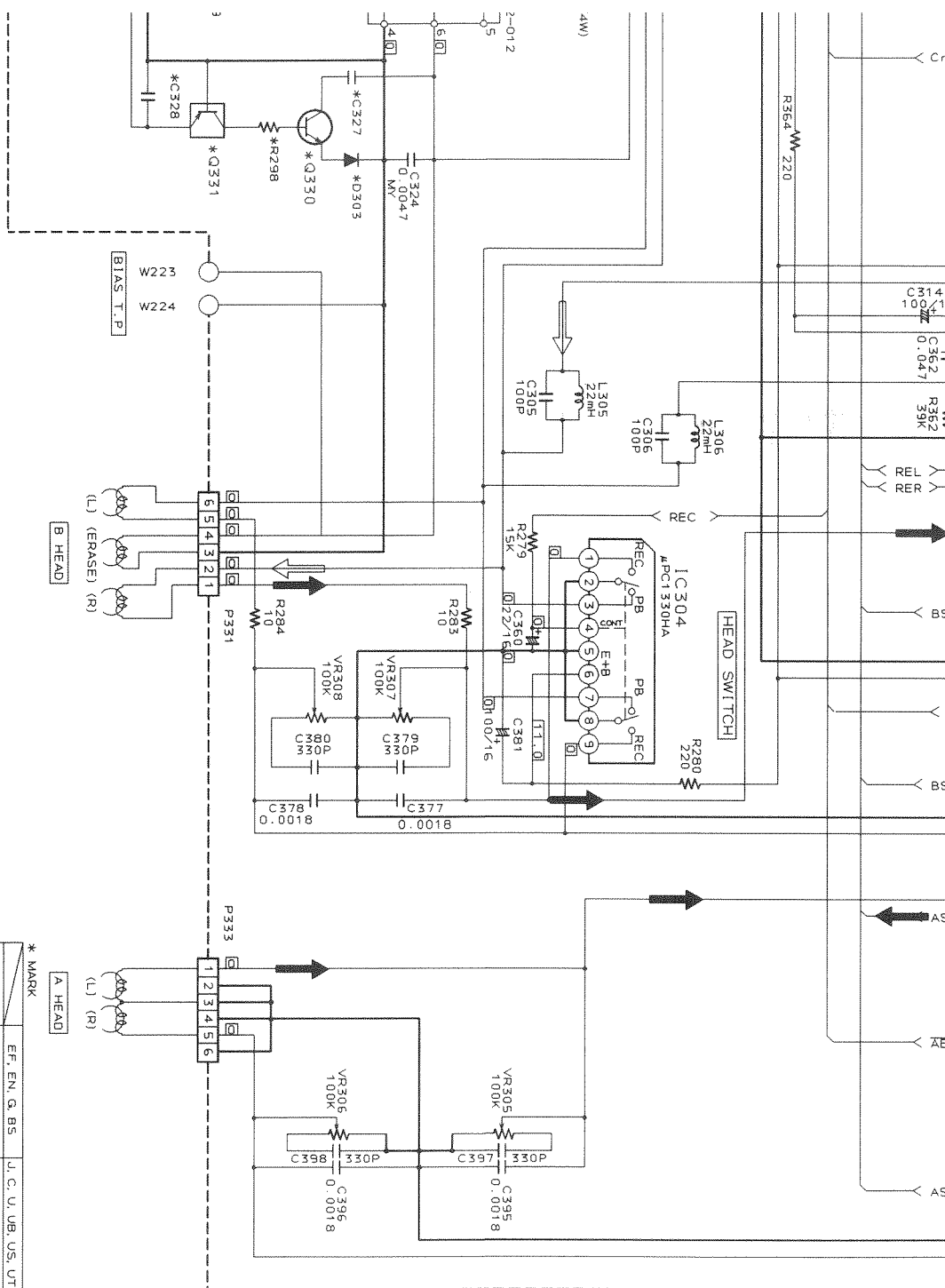

* MARK

REF.	EN	Q	BS	J	C	U	UB	VS	UT
C327			4.70P					NONE	
C328			0.022					NONE	
C319			0.022					NONE	
R298			560					NONE	
R365, 366			4.7					SHORT	
R383, 384			4.7					SHORT	
Q330			2SC945A					NONE	
Q331			DTA144E					NONE	
D303			1SS119					NONE	
C393, 394			4.70P					100P	
C375, 376			4.70P					100P	

11 | 12 | 13 | 14 | 15 | 16 | 17 | 18 | 19 | 20

ENCJ-097-1

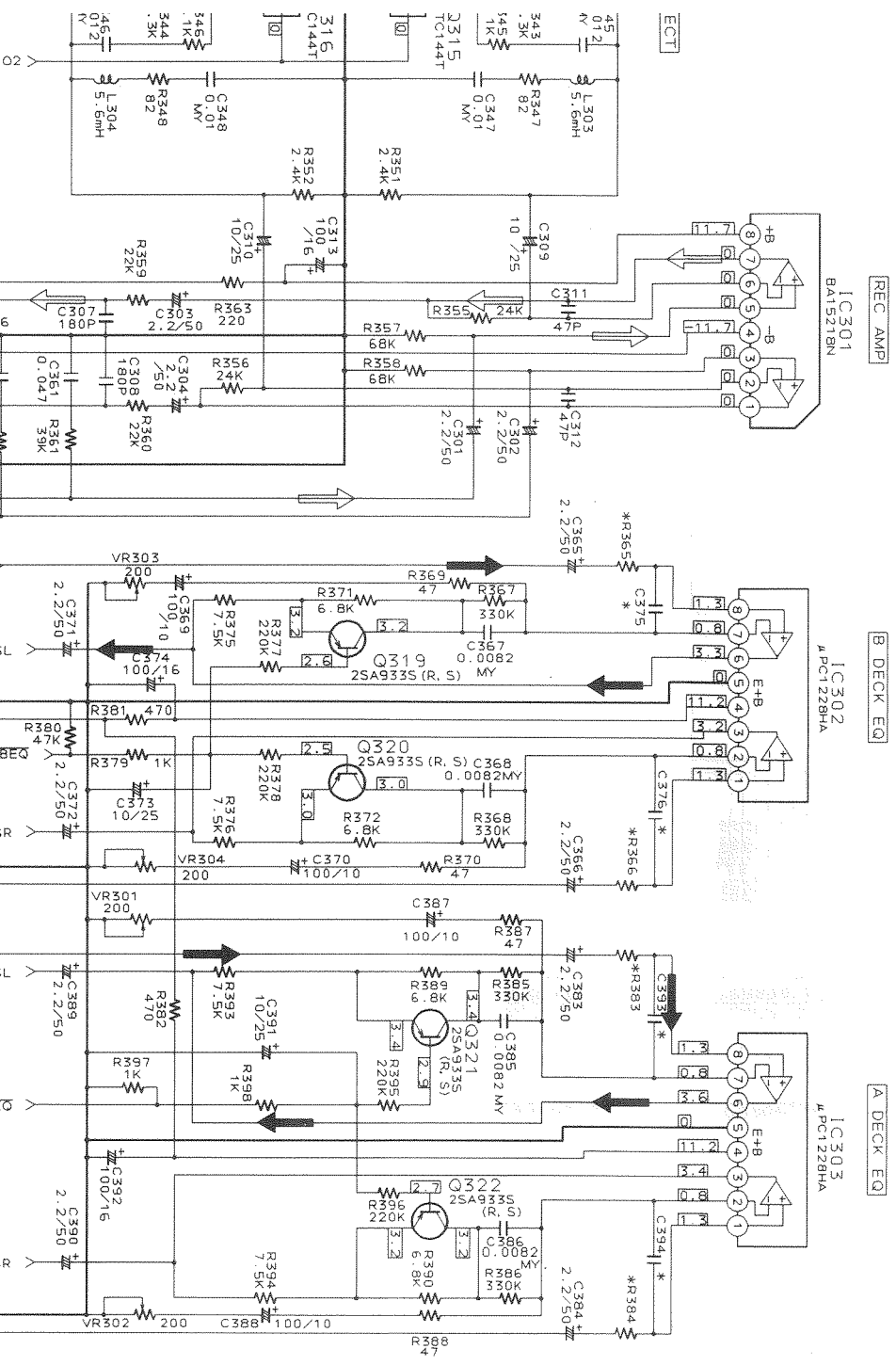

<p>FX-F3000 FX-F3000R</p>

Contents

<i>Description of Major ICs</i>	5-2
<i>Disassembly Procedures</i>	5-8
<i>Adjustment Procedures</i>	5-9
<i>Block Diagram</i>	5-10
<i>Printed Circuit Board</i>	5-11
<i>Schematic Diagrams</i>	5-12

Description of Major LSIs

■ MN172124J6E (IC201) : SYSTEM CONTROLLER

1. Terminal Layout

63 ~ 43	
64	42
}	}
84	22
1 ~ 21	

2. Key Matrix

※ :FX-F3000R

	KEY IN 0 (PIN56)	KEY IN 1 (PIN57)	KEY IN2 (PIN58)	KEY IN3 (PIN59)
KEY OUT 0 (PIN60)	MEMORY (S201)	CLOCK ADJ (S202)	REC (S203)	DAILY (S204)
KEY OUT 1 (PIN61)	TUNING/TIMER DOWN (S205)	TUNING/TIMER UP (S206)	PRESET / PTY DOWN (S207)	PRESET / PTY UP (S208)
KEY OUT 2 (PIN62)			FM (S209)	AM (S210)
KEY OUT 3 (PIN63)	※ DISPLAY (S211)	※ EON ON/OFF (S212)	※ EON MODE (S213)	※ PTY SEARCH (S214)

3. Description

Pin No.	Symbol	I/O	Description	Pin No.	Symbol	I/O	Description
1	7G	O	FL grid control	43	TUDATA	O	Data for PLL synthesizer
2	6G	O	FL grid control	44	fout	O	Clock frequency
3	5G	O	FL grid control	45	RDS CLK	I	Clock input from IC191
4	4G	O	FL grid control	46	RDS DATA	I	Data signal from IC191
5	3G	O	FL grid control	47	RDS RST	O	Reset signal for IC191
6	2G	O	FL grid control	48	INH	I	Inhibit signal input
7	1G	O	FL grid control	49	RDS D.ST	I	D.Start signal from IC191
8	P1	O	FL anode control	50	TUNED	I	TUNED indication control
9	P2	O	FL anode control	51	STEREO	I	STEREO indication control
10	P3	O	FL anode control	52	MUTE	O	Muting tuner sound
11	P4	O	FL anode control	53		--	Not used
12	P5	O	FL anode control	54	DCS OUT	O	Compulink signal output
13	P6	O	FL anode control	55	DCS IN	I	Compulink signal input
14	P7	O	FL anode control	56	KI0	I	Key matrix input
15	P8	O	FL anode control	57	KI1	I	Key matrix input
16	P9	O	FL anode control	58	KI2	I	Key matrix input
17	P10	O	FL anode control	59	KI3	I	Key matrix input
18	P11	O	FL anode control	60	KO0	O	Key matrix output
19	P12	O	FL anode control	61	KO1	O	Key matrix output
20	P13	O	FL anode control	62	KO2	O	Key matrix output
21	P14	O	FL anode control	63	KO3	O	Key matrix output
22	P15	O	FL anode control	64	KO4	O	Key matrix output
23	VP	--	Power supply for FL display	65	KO5	O	Key matrix output
24	P16	O	FL anode control	66	KO6	O	Key matrix output
25	P17	O	FL anode control	67	KO7	O	Key matrix output
26	P18	O	FL anode control	68	RST	I	Reset signal input
27	P19	O	FL anode control	69		--	GND
28	P20	O	FL anode control	70		--	Not used
29	P21	O	FL anode control	71		--	GND
30	P22	O	FL anode control	72	OSC2	I/O	Clock oscillation terminal
31	P23	O	FL anode control	73	OSC1	I/O	Clock oscillation terminal
32	P24	O	FL anode control	74	VDD	--	Power supply
33	P25	O	FL anode control	75	TEST	I	TEST mode
34	P26	O	FL anode control	76	FM IND.	O	FM indication control
35	P27	O	FL anode control	77	AM IND.	O	AM indication control
36	P28	O	FL anode control	78	P35	O	FL anode control
37	P29	O	FL anode control	79	P34	O	FL anode control
38	P30	O	FL anode control	80	P33	O	FL anode control
39	P36	O	FL anode control	81	P32	O	FL anode control
40	CE	O	Chip enable signal for PLL synthesizer	82	P31	O	FL anode control
41	CLK	O	Clock for PLL synthesizer	83	9G	O	FL grid control
42	IFDATA	I	Data from PLL synthesizer	84	8G	O	FL grid control

■ LC72131M (IC121) : PLL Synthesizer

1. Terminal Layout

XIN	1	20	XOUT
CE	2	19	VSS
TDATA	3	18	LPF OUT
CK	4	17	LPF IN
IFDATA	5	16	PD
FM	6	15	VDD
MW	7	14	FM OSC
LW	8	13	AM OSC
AUTO/MONO	9	12	IF REQ
POWER	10	11	FM/AM IF

2. Block Diagram

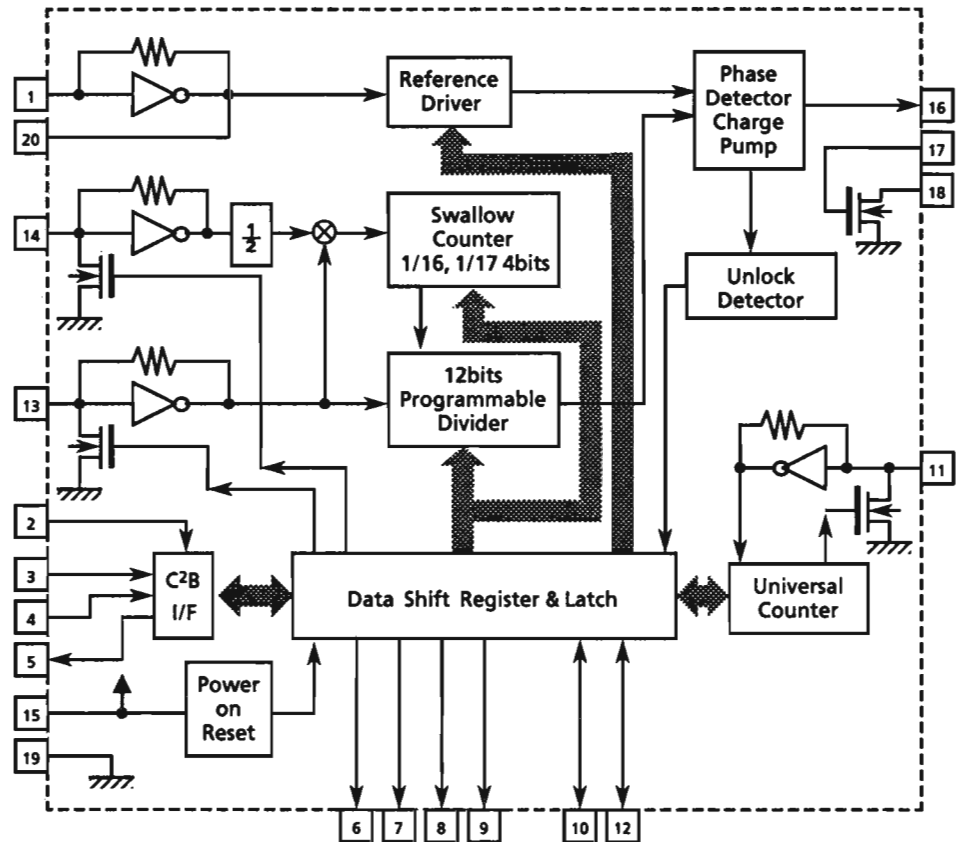

3. Pin Functions

Pin No.	Symbol	I/O	Functions	Pin No.	Symbol	I/O	Functions
1	X in	I	Crystal oscillator (7.2MHz).	11	FM/AM IF	I	Universal counter input
2	CE	I	Fix the chip enable to "H" when inputting (DI) and outputting (DO) the serial data.	12	IF REQ	O	Output the "IF-signal request" to IC102
3	TDATA	I	Receive the control data from the controller (IC201).	13	AM IN	I	Input the local oscillator signal of AM.
4	CK	I	This clock is used to synchronize data when transmitting the data of DI and DO.	14	FM IN	I	Input the local oscillator signal of FM.
5	IFDATA	O	Transmit the data from LC72131M to the controller which is synchronized with CK.	15	VDD	-	This is a terminal of power supply.
6	FM	O	It is "L" on FM mode.	16	PD	O	PLL charge pump output: When the local oscillator signal frequency is higher than the reference frequency high level signals will output. When it is lower than the reference frequency, low level signals will output. When it is same as reference frequency signals, it will be floating.
7	MW	O	It is "L" on MW mode.	17	LPF IN	I	Transistor used for the PLL active low-pass filter
8	LW	O	It is "L" on LW mode.	18	LPF OUT	O	Transistor used for the PLL active low-pass filter
9	AUTO/MONO	O	It is "L" on monaural, "H" on auto.	19	VSS	-	Connected to GND
10	POWER	O	Regulator control signal P ON "H", STANDBY "L"	20	X out	O	Crystal oscillator (7.2MHz).

■ SAA6579T (IC192) : Radio data system demodulator (Used for FX-F3000R)

1. Terminal Layout

QUAL	1	16	RDCL
RDDA	2	15	T57
Vref	3	14	OSCO
MUX	4	13	OSCI
VDDA	5	12	VDD
GND	6	11	GND
CIN	7	10	GND
SCOUT	8	9	GND

2. Pin Function

Pin No.	Symbol	I/O	Function
1	QUAL	—	Non connection
2	RDDA	O	RDS data output
3	Vref	O	Reference voltage output
4	MUX	I	Multiplex signal input
5	VDDA	—	+5V supply voltage for analog part
6	GND	—	Ground for analog part (0V)
7	CIN	I	Subcarrier input to comparator
8	SCOUT	O	Subcarrier output of reconstruction filter
9	GND	—	Ground for digital part (0V)
10	GND	—	Ground for digital part (0V)
11	GND	—	Ground for digital part (0V)
12	VDD	—	+5V supply voltage for digital part
13	OSCI	I	Oscillator input
14	OSCO	O	Oscillator output
15	T57	—	Non connection
16	RDCL	O	RDS clock output

3. Block Diagram

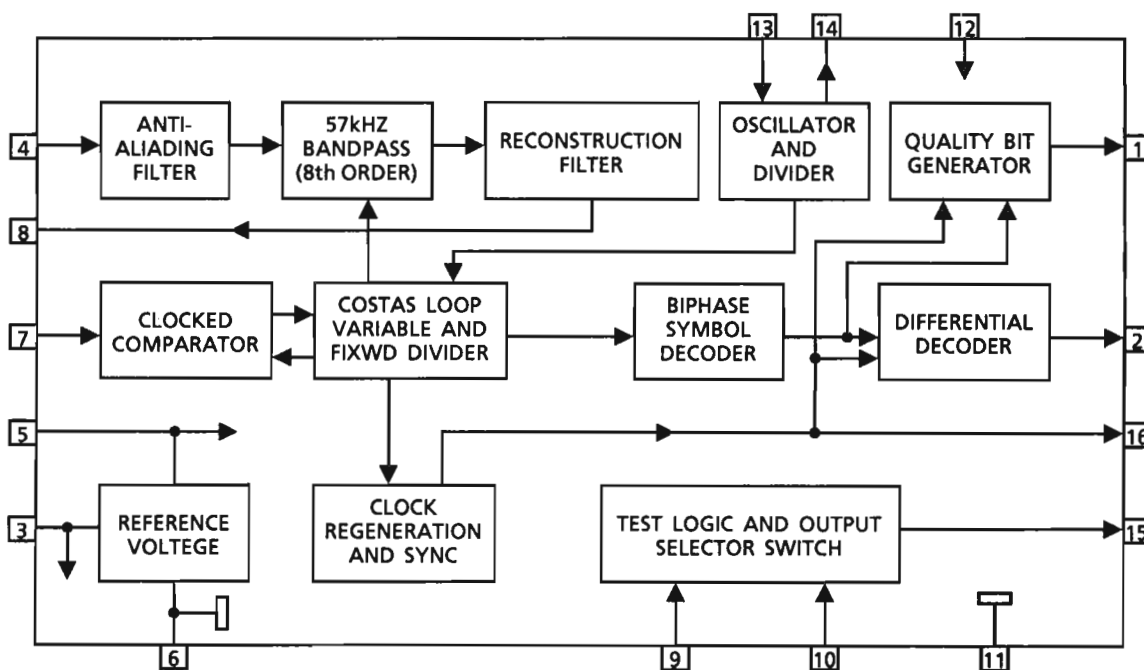

■ LA1836M (IC102) : FM AM IF AMP & detector, FM MPX Decoder

1. Terminal Layout

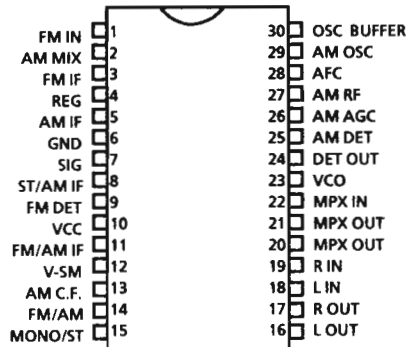

3. Pin Function

Pin No.	Symbol	I/O	Function
1	FM IN	I	This is an input terminal of FM IF Signal.
2	AM MIX	O	This is an output terminal for AM mixer.
3	FM IF	I	Bypass of FM IF
4	REG	—	Register value between pin4 and pin28 desides the frequency width of the input signal.
5	AM IF	I	Input of AM IF Signal.
6	GND	—	This is the device ground terminal.
7	SIG	O	When the set is tuning ,this terminal becomes "L".
8	ST/AM IF	O	Stereo indicator output. Stereo : "L", Mono : "H"
9	FM DET	—	FM detect transformer.
10	VCC	—	This is the power supply terminal.
11	FM/AM IF //MUTE	O/I	When the signal of IF REQ of IC121(LC72131M) appear, the signal of FM/AM IF output. //Muting control input.
12	VSM	O	S Meter output and adjust AM SD sensitivity.
13	AM C.F.	O	This is a terminal of AM ceramic filter.
14	FM/AM	I	Change over the FM/AM input. "H" : FM, "L" : AM
15	MONO/ST	O	Stereo : "H", Mono : "L"
16	L OUT	O	Left channel signal output.
17	R OUT	O	Right channel signal output
18	L IN	I	Input terminal of the Left channel post AMP.
19	R IN	I	Input terminal of the Right channel post AMP.
20	MPX L OUT	O	Mpx Left channel signal output.
21	MPX R OUT	O	Mpx Right channel signal output.
22	MPX IN	I	Mpx input terminal.
23	VCO	I	Voltage controlled oscillator terminal.
24	DET OUT	O	AM/FM detection output.
25	AM DET	—	AM low cut adjustment.
26	AM AGC	I	This is an AGC voltage input terminal for AM.
27	AM RF	I	This is an input terminal for AM RF signal.
28	AFC	—	This is an output terminal of voltage for FM-AFC.
29	AM OSC	—	This is a terminal of AM Local oscillation circuit.
30	OSC BUFFER	O	AM Local oscillation signal output.

2. Block Diagram

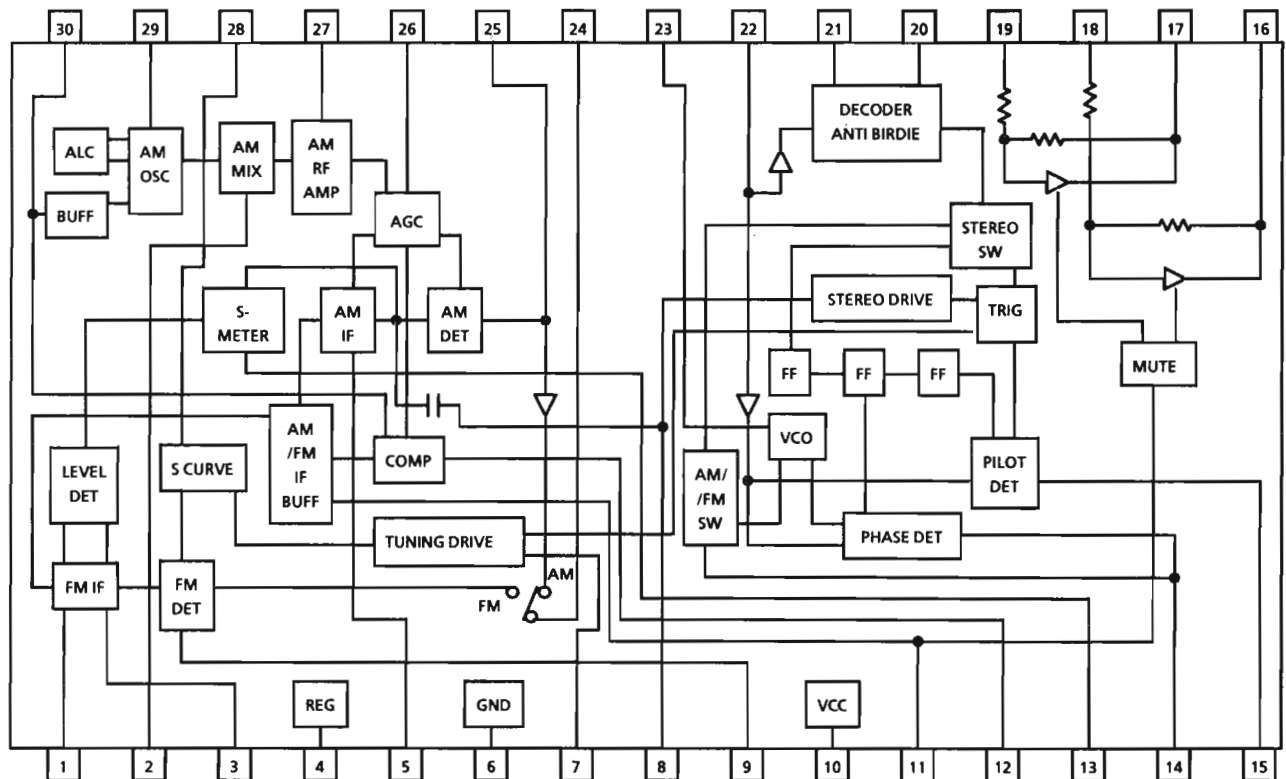

■ LC7073M (IC191) : Radio Data System (Used for FX-F3000R)

1. Terminal Layout

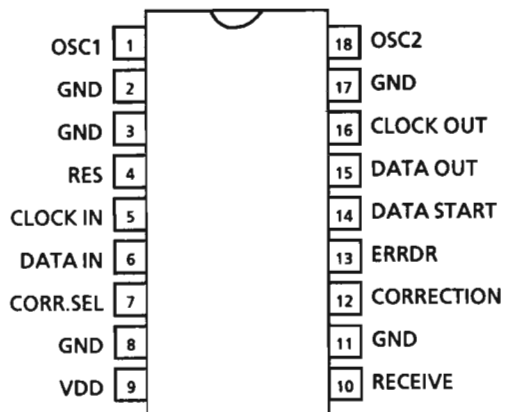

2. Block Diagram

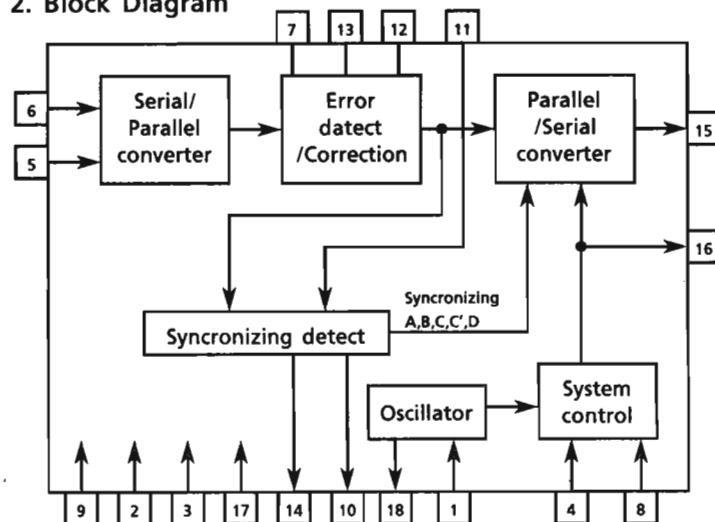

3. Pin Functions

Pin No.	Symbol	I/O	Function	Pin No.	Symbol	I/O	Function
1	OSC1	I	Oscillation terminal	10	RECEIVE	—	Non connection
2	GND	—	GND	11	GND	—	GND
3	GND	—	GND	12	CORRECTION	—	Non connection
4	RES	I	Reset input	13	ERRDR	—	Non connection
5	CLOCK IN	I	RDS clock input	14	DATA START	O	Data start signal for block data to output serial data
6	DATA IN	I	RDS data input	15	DATA OUT	O	Serial data output
7	CORR.SEL	I	Non connection	16	CLOCK OUT	O	Data output of serial data output
8	GND	—	GND	17	GND	—	GND
9	VDD	—	Power supply	18	OSC2	O	Oscillation terminal

Internal Connections of the FL Display

■ ELU0001-205 : (DI201)

1. Grid Assignment

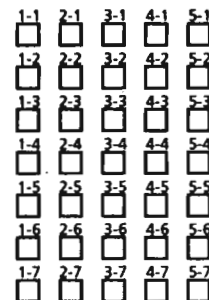
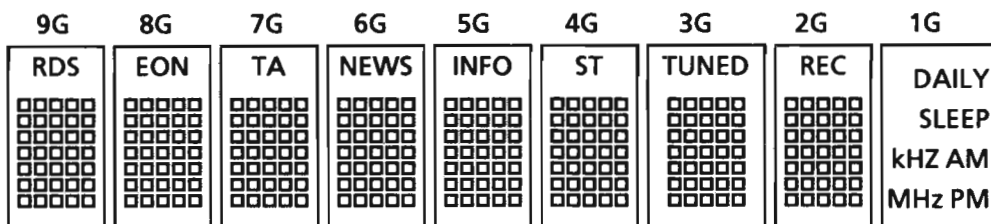

(9G~2G)

2. Pin Connection

Pin No.	1	2	3	4	5	6	7	8	9	10	11	12	13	14	15	16	17	18	19	20	21	22	23	24
Connection	F1	F1	F1	NP	NP	NC	P31	P30	P29	P28	P27	P26	P25	P24	P23	P22	P21	P20	P19	P18	P17	P16	P15	P14
Pin No.	25	26	27	28	29	30	31	32	33	34	35	36	37	38	39	40	41	42	43	44	45	46	47	48
Connection	P13	P12	P11	P10	9P	P8	P7	NP	NP	F2	F2	F2	F2	F2	F2	NP	NP	IC	P6	P5	P4	P3	P2	P1
Pin No.	49	50	51	52	53	54	55	56	57	58	59	60	61	62	63	64	65	66	67	68	69	70	71	72
Connection	NC	NC	NC	NC	NC	1G	2G	3G	4G	5G	6G	7G	8G	9G	P36	P35	P34	P33	P32	NP	NP	F1	F1	F1

(NOTE) F1,F2 : Filament, NP : No pin, NC : No connection, 1G~9G : Grid, P : Anode IC : Internal connection,

3. Anode Connection

	9G	8G	7G	6G	5G	4G	3G	2G	1G		9G	8G	7G	6G	5G	4G	3G	2G	1G
P1	1-1	1-1	1-1	1-1	1-1	1-1	1-1	1-1	DAILY	P19	4-4	4-4	4-4	4-4	4-4	4-4	4-4	4-4	—
P2	2-1	2-1	2-1	2-1	2-1	2-1	2-1	2-1	SLEEP	P20	5-4	5-4	5-4	5-4	5-4	5-4	5-4	5-4	—
P3	3-1	3-1	3-1	3-1	3-1	3-1	3-1	3-1	AM	P21	1-5	1-5	1-5	1-5	1-5	1-5	1-5	1-5	—
P4	4-1	4-1	4-1	4-1	4-1	4-1	4-1	4-1	PM	P22	2-5	2-5	2-5	2-5	2-5	2-5	2-5	2-5	—
P5	5-1	5-1	5-1	5-1	5-1	5-1	5-1	5-1	MHz	P23	3-5	3-5	3-5	3-5	3-5	3-5	3-5	3-5	—
P6	1-2	1-2	1-2	1-2	1-2	1-2	1-2	1-2	kHz	P24	4-5	4-5	4-5	4-5	4-5	4-5	4-5	4-5	—
P7	2-2	2-2	2-2	2-2	2-2	2-2	2-2	2-2	—	P25	5-5	5-5	5-5	5-5	5-5	5-5	5-5	5-5	—
P8	3-2	3-2	3-2	3-2	3-2	3-2	3-2	3-2	—	P26	1-6	1-6	1-6	1-6	1-6	1-6	1-6	1-6	—
P9	4-2	4-2	4-2	4-2	4-2	4-2	4-2	4-2	—	P27	2-6	2-6	2-6	2-6	2-6	2-6	2-6	2-6	—
P10	5-2	5-2	5-2	5-2	5-2	5-2	5-2	5-2	—	P28	3-6	3-6	3-6	3-6	3-6	3-6	3-6	3-6	—
P11	1-3	1-3	1-3	1-3	1-3	1-3	1-3	1-3	—	P29	4-6	4-6	4-6	4-6	4-6	4-6	4-6	4-6	—
P12	2-3	2-3	2-3	2-3	2-3	2-3	2-3	2-3	—	P30	5-6	5-6	5-6	5-6	5-6	5-6	5-6	5-6	—
P13	3-3	3-3	3-3	3-3	3-3	3-3	3-3	3-3	—	P31	1-7	1-7	1-7	1-7	1-7	1-7	1-7	1-7	—
P14	4-3	4-3	4-3	4-3	4-3	4-3	4-3	4-3	—	P32	2-7	2-7	2-7	2-7	2-7	2-7	2-7	2-7	—
P15	5-3	5-3	5-3	5-3	5-3	5-3	5-3	5-3	—	P33	3-7	3-7	3-7	3-7	3-7	3-7	3-7	3-7	—
P16	1-4	1-4	1-4	1-4	1-4	1-4	1-4	1-4	—	P34	4-7	4-7	4-7	4-7	4-7	4-7	4-7	4-7	—
P17	2-4	2-4	2-4	2-4	2-4	2-4	2-4	2-4	—	P35	5-7	5-7	5-7	5-7	5-7	5-7	5-7	5-7	—
P18	3-4	3-4	3-4	3-4	3-4	3-4	3-4	3-4	—	P36	RDS	EON	TA	NEWS	INFO	ST	TUNED	REC	—

Disassembly Procedures

- (1) Removing the top cover
1. Remove 2 screws (A) fastening both sides of top cover, and 4 screws (B) fastening the rear side.
 2. Remove the top cover.

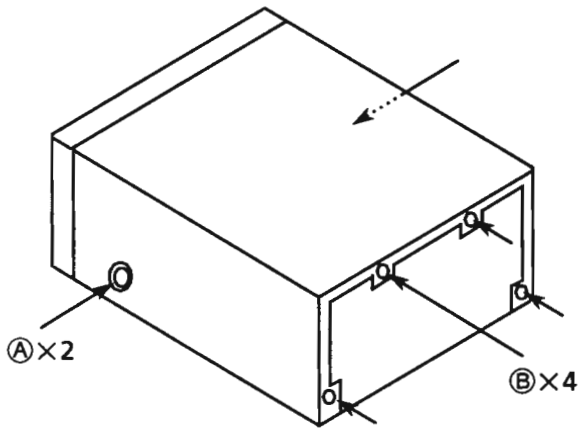

FIG. 1

- (3) Removing the Front Panel Assembly
1. Removing the top cover.
 2. Remove 2 screws (C) fastening bottom of the front panel.
 3. Remove 2 hooks (a) fastening the assembly with chassis to remove the assembly.

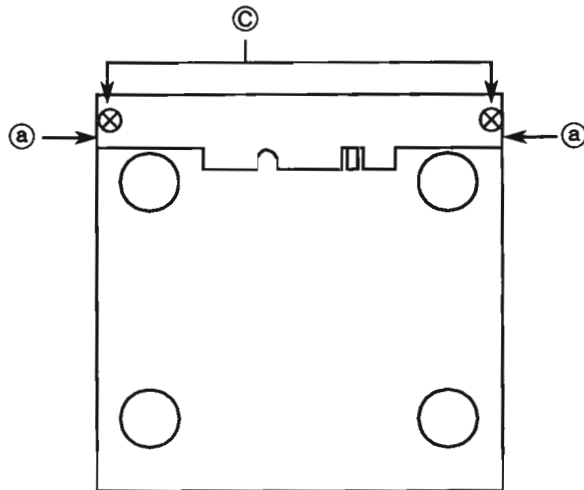

FIG. 2

- (3) Removing the front circuit board
1. Removing the front panel assembly.
 2. Remove 5 screws (D) to remove the front circuit board. (FX-F3000R : Remove a screw (D'))
 3. Remove it.

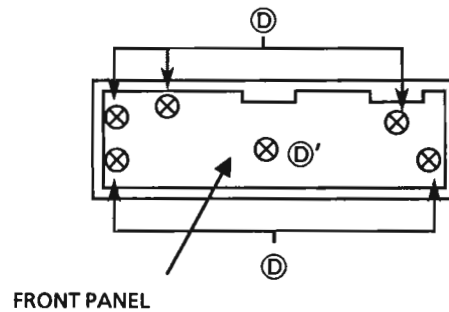

FIG. 3

(A) .. SDSG3008N (B) ... GBSG3008CC (C) ... SDSG3008CC (D) ... SDSF2608Z

Adjustment Procedures

Tuning range

Area	Range		
	LW (kHz)	MW (kHz)	FM (MHz)
Continental Europe, the U.K	144~288	522~1629	87.5MHz~108MHz
Universal type (AM Channel space 9kHz)	—	531~1602	
Universal type (AM Channel space 10kHz)	—	530~1600	
U.S.A,CANADA	—	530~1710	

(1) Tuning voltage

Confirm the voltages in the table below at TP101.

FM Tuning voltage (Unit : V)

Area	Frequency	
	87.5MHz	108MHz
the U.K. , Continental Europe, Universal U.S.A & CANADA	1.3 <	9.0 >

AM Tuning voltage (Unit : V)

Area	Frequency (MW)							Frequency (LW)	
	522KHz	530KHz	531KHz	1600KHz	1602KHz	1629KHz	1629KHz	144kHz	288kHz
the U.K. , Continental Europe	0.8 <	—	—	—	—	<9.0	—	0.8 <1.0	6.5 <9.0
Universal (Channel space 9kHz)	—	—	0.8 <	—	8.0 <	—	—	—	—
Universal (Channel space 10kHz)	—	0.8 <	—	8.0 <	—	—	—	—	—
U.S.A,CANADA	—	0.8 <	—	—	—	—	<9.0	—	—

(2) FM center meter

Receive a broadcast by using the function of 'AUTO STOP'.

Adjust T141 (detector coil) so that the voltage at TP102 becomes $0 \pm 1.5mV$.

(3) Clock Adjustment

1. After connecting B154 and B155 with some wire as shown in figure below, connect the AC power cord into an AC outlet.
2. Confirm that the display is off and remove the wire.
3. Connect a frequency counter to B165 and B269.
4. Adjust TC201 so that the frequency becomes $50000.00 \pm 0.38Hz$.

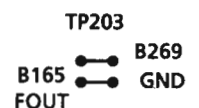
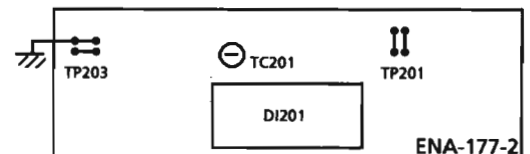
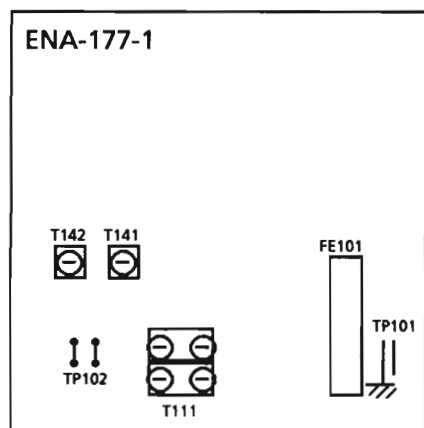

Block Diagram

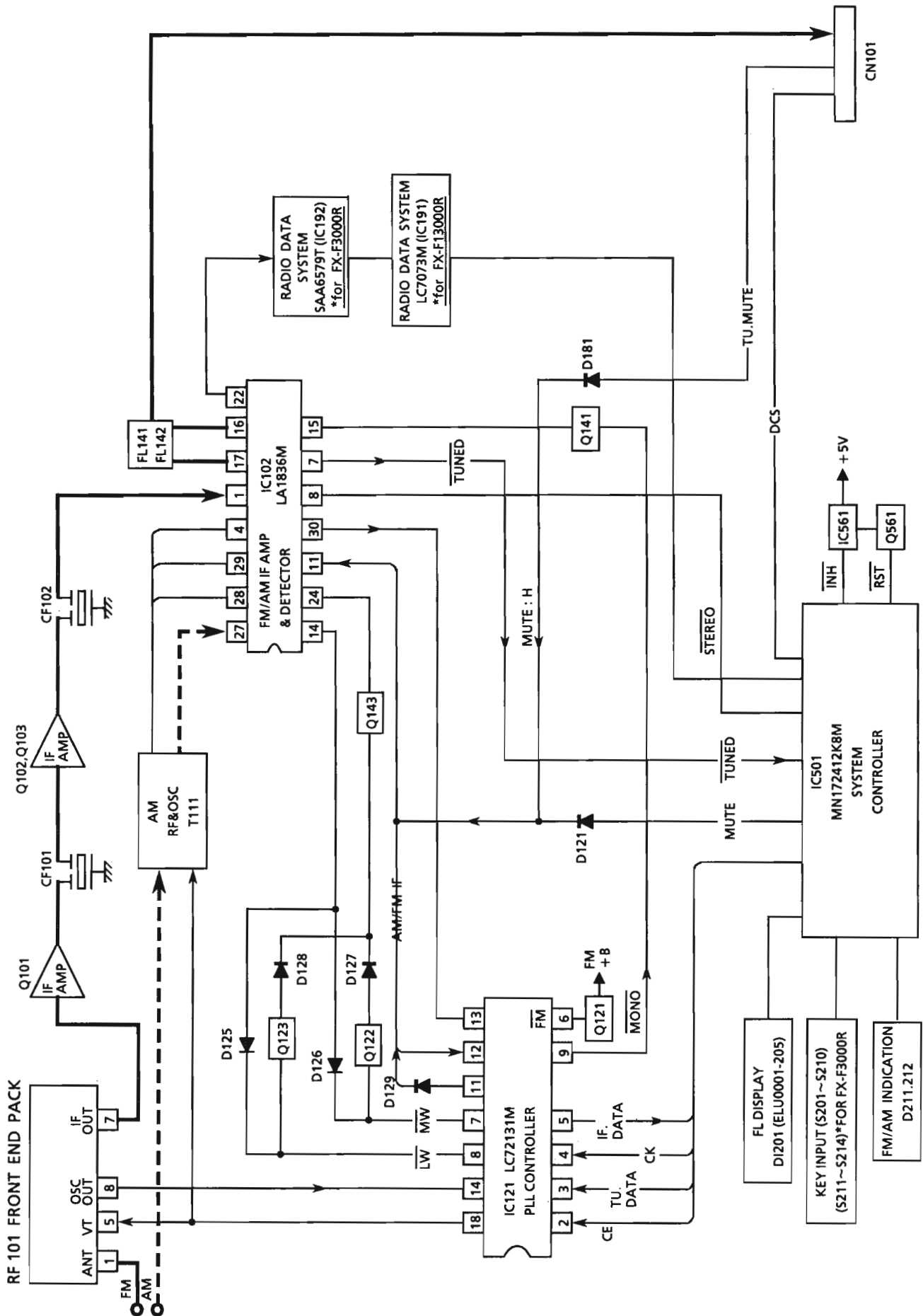

P5-11-a

P5-11-b

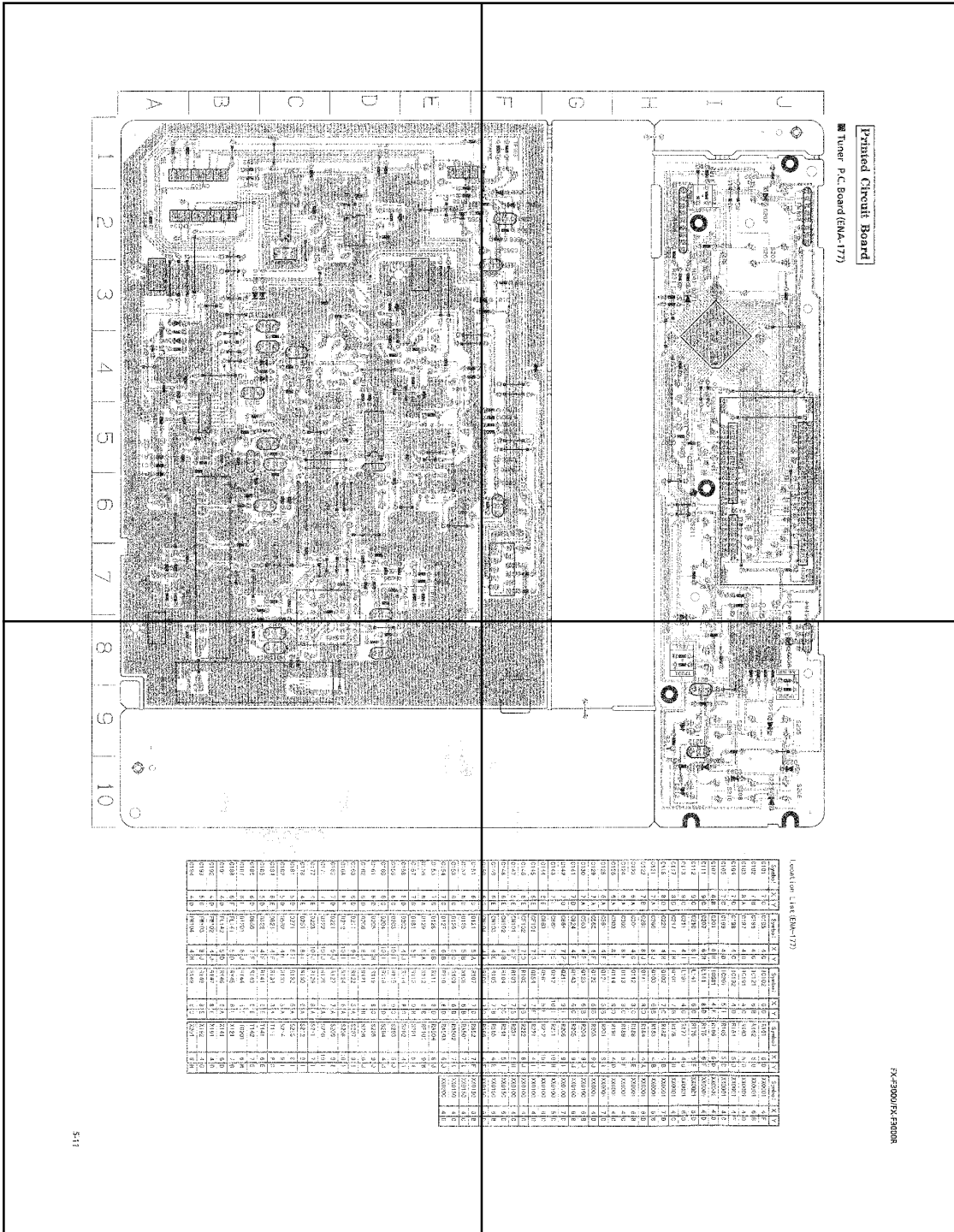

P5-11-c

P5-11-d

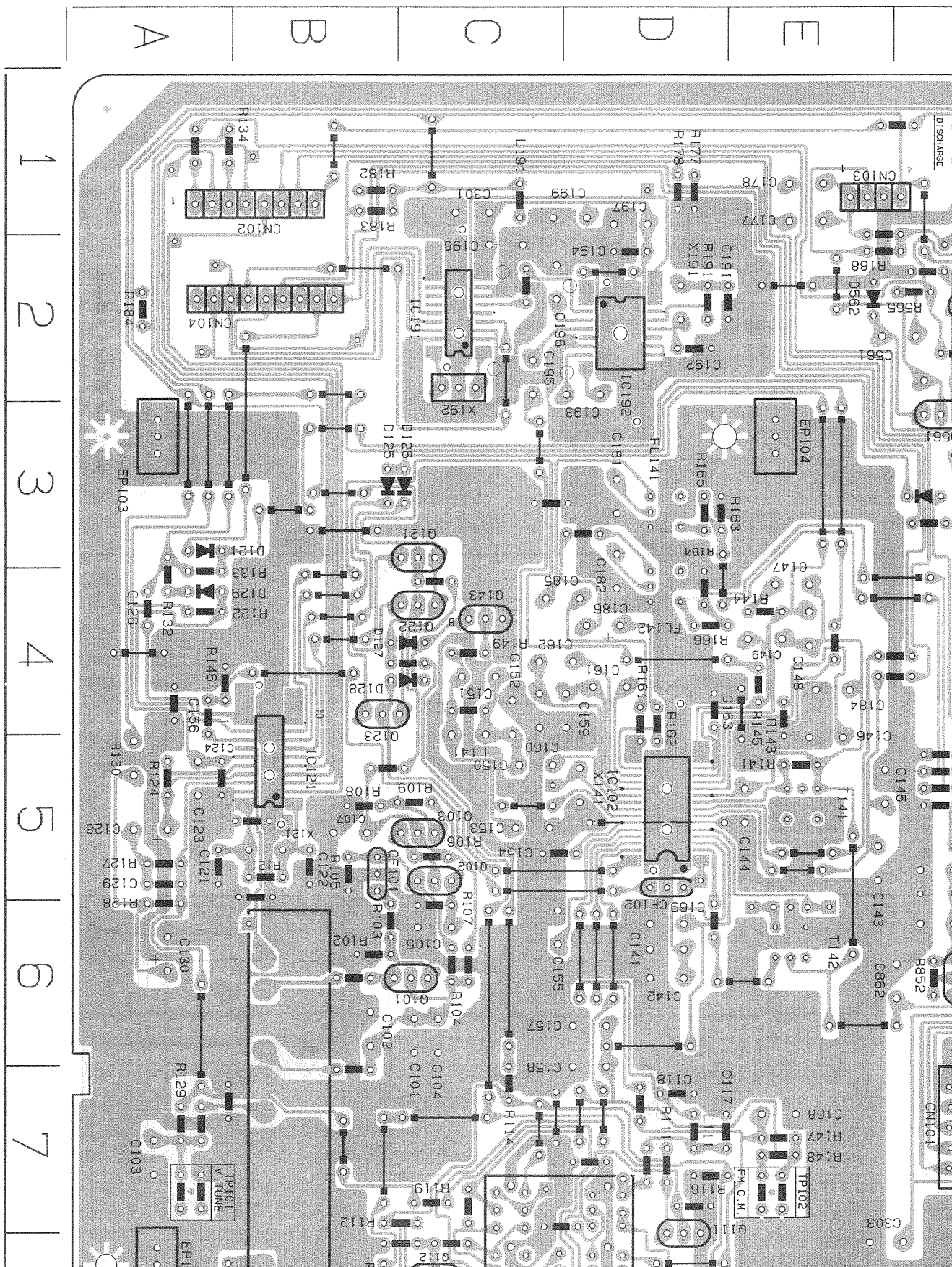

Printed Circuit Board

■ Tuner P.C. Board (ENA-177)

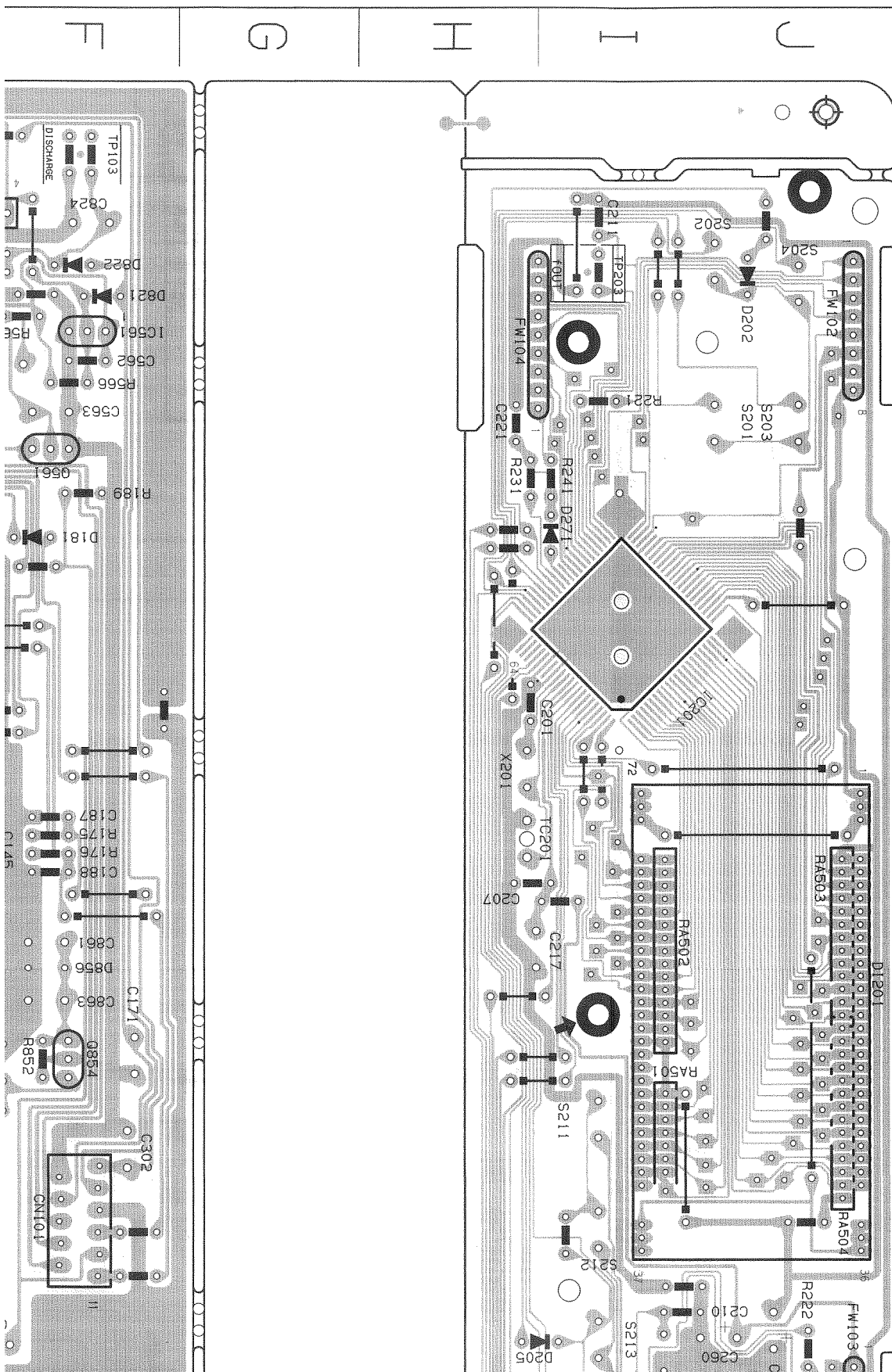

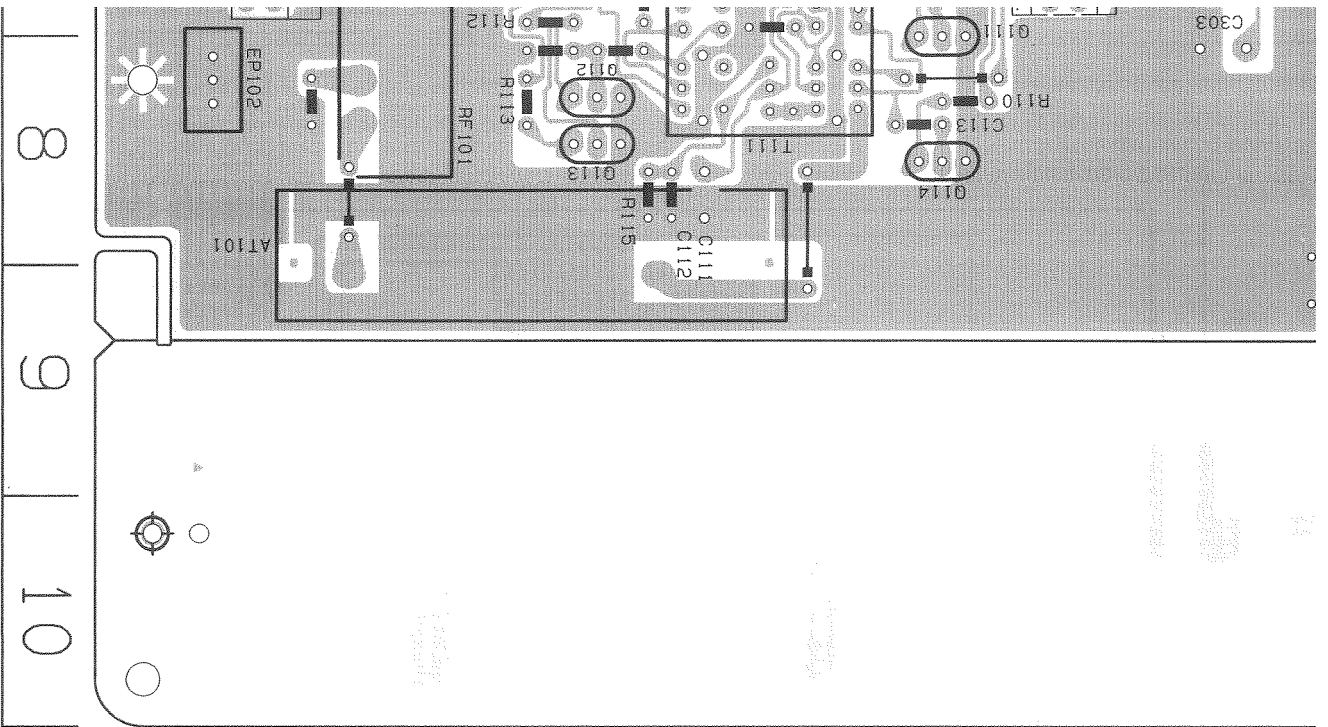

C149	6 E	CN103	4 E	R105	7 B	R565	4 E	XX0150	6 B
C150	6 C	CN104	4 A	R106	7 C	R566	4 F	XX0150	6 D
C151	6 C	D121	5 A	R107	7 C	R852	7 F	XX0150	6 B
C152	6 C	D125	5 B	R108	6 B	RA501	7 I	XX0150	4 C
C153	6 C	D126	5 C	R109	6 B	RA502	7 I	XX0150	4 C
C154	7 C	D127	6 B	R110	8 D	RA503	6 J	XX0200	4 D
C155	7 C	D128	6 B	R111	8 D	RA504	8 J		
C156	6 A	D129	5 A	R112	8 B	RF101	9 B		
C157	7 D	D181	5 F	R113	9 B	S201	5 I		
C158	8 D	D202	4 J	R114	8 C	S202	4 I		
C159	6 C	D203	10 I	R115	9 C	S203	5 J		
C160	6 C	D204	10 I	R116	8 D	S204	4 J		
C161	6 D	D205	8 H	R119	8 C	S205	9 J		
C162	6 D	D206	8 J	R121	7 B	S206	10 J		
C163	6 D	D211	9 I	R122	5 A	S207	9 I		
C168	8 E	D212	10 I	R124	6 A	S208	10 I		
C169	7 D	D221	9 J	R127	7 A	S209	9 I		
C171	7 F	D222	10 J	R128	7 A	S210	10 I		
C177	4 E	D223	10 J	R129	8 A	S211	7 I		
C178	4 E	D251	8 I	R130	6 A	S212	8 I		
C181	5 D	D271	5 I	R132	5 A	S213	8 I		
C182	5 D	D562	4 E	R133	5 A	S214	9 I		
C184	6 E	D821	4 F	R134	3 A	T111	8 C		
C185	5 D	D822	4 F	R141	6 E	T141	6 E		
C186	6 D	D856	7 F	R143	6 E	T142	7 E		
C187	6 F	D1201	6 J	R144	5 E	T0201	6 H		
C188	6 F	FL141	5 D	R145	6 E	X121	7 B		
C191	4 D	FL142	5 D	R146	6 A	X141	6 D		
C192	4 D	FW102	4 J	R147	8 E	X191	4 D		
C193	5 C	FW103	8 J	R148	8 E	X192	4 C		
C194	4 D	FW104	4 H	R149	6 C	X201	6 H		

P5-12-a

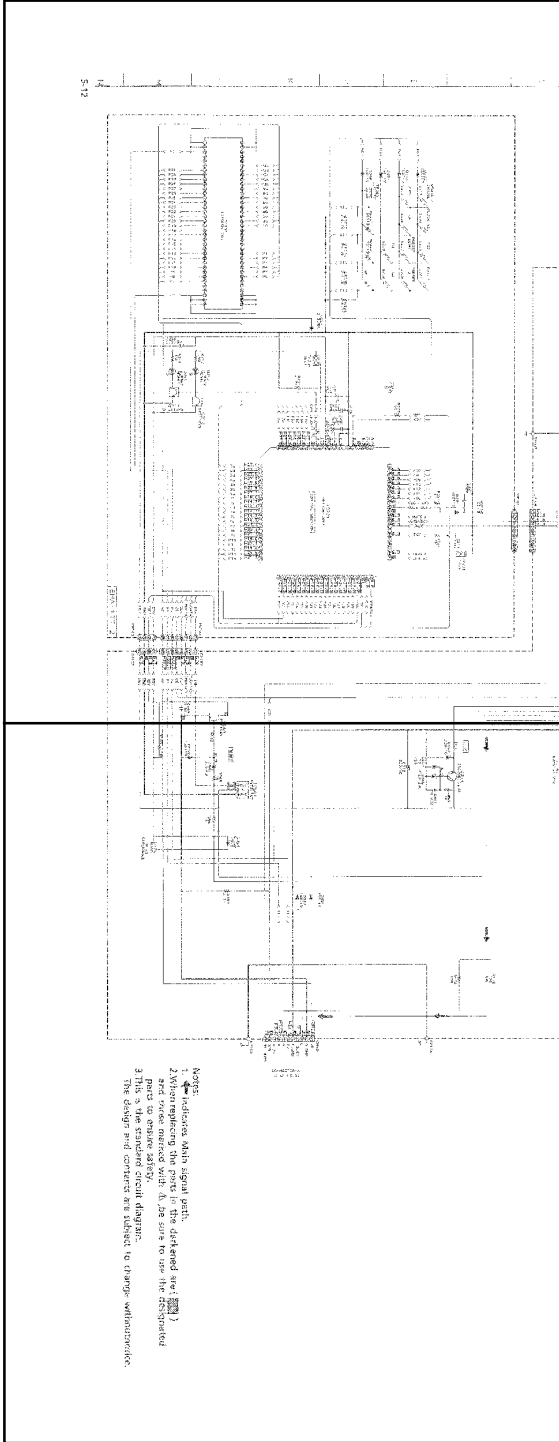

P5-12-b

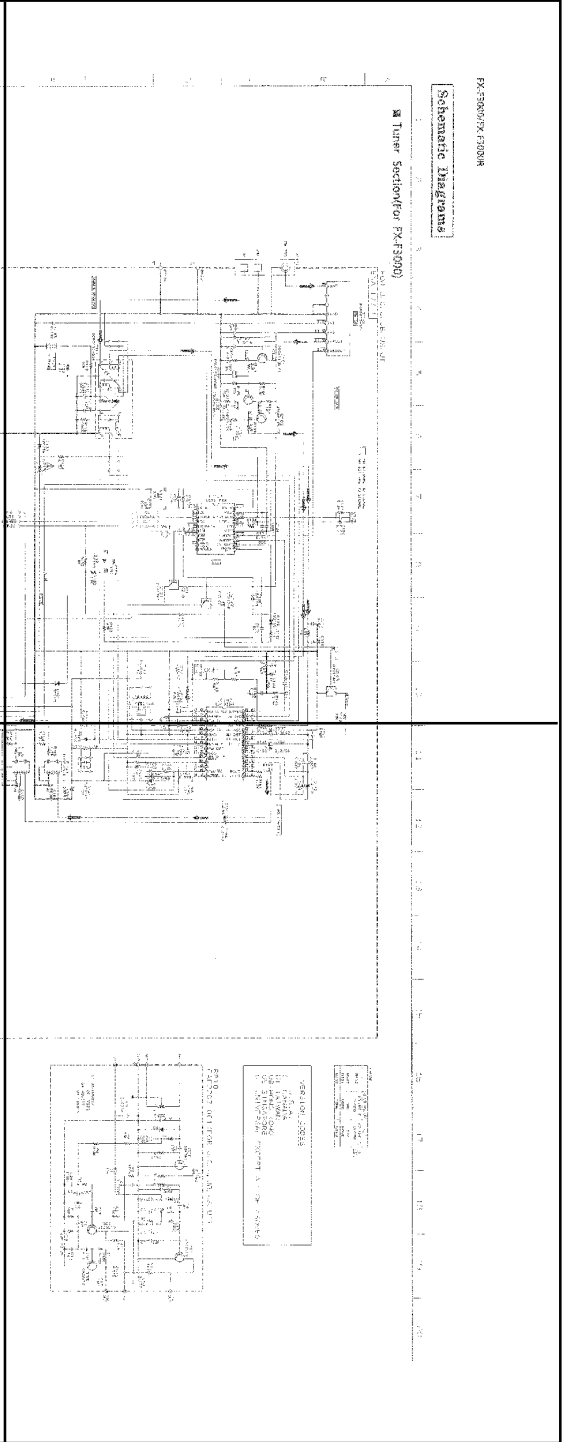

P5-12-c

P5-12-d

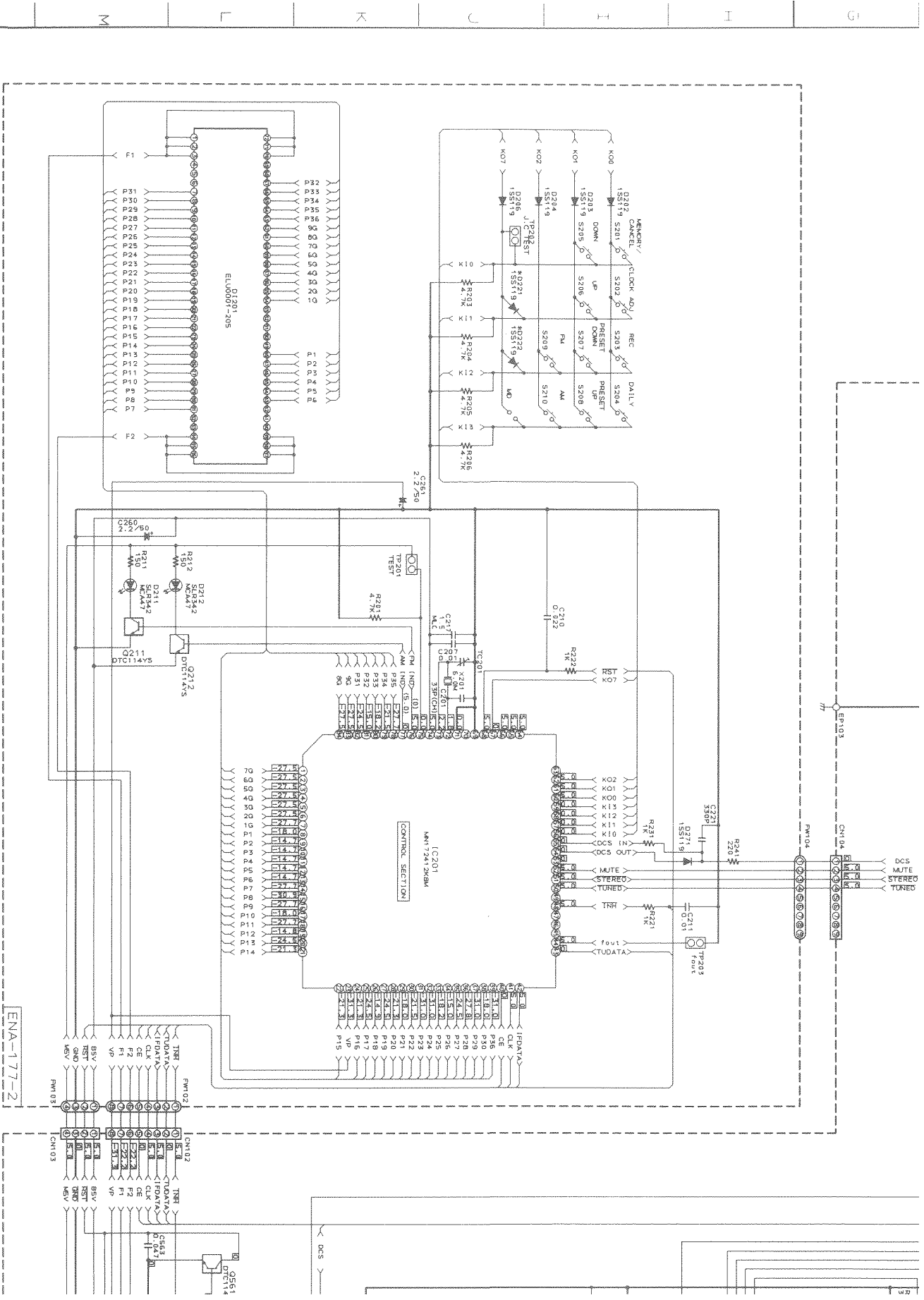

Schematic Diagrams

1 2 3 4 5 6 7 8 9 10



Tuner Section(For FX-F3000)

FOR J. C. U. UB. US. UT

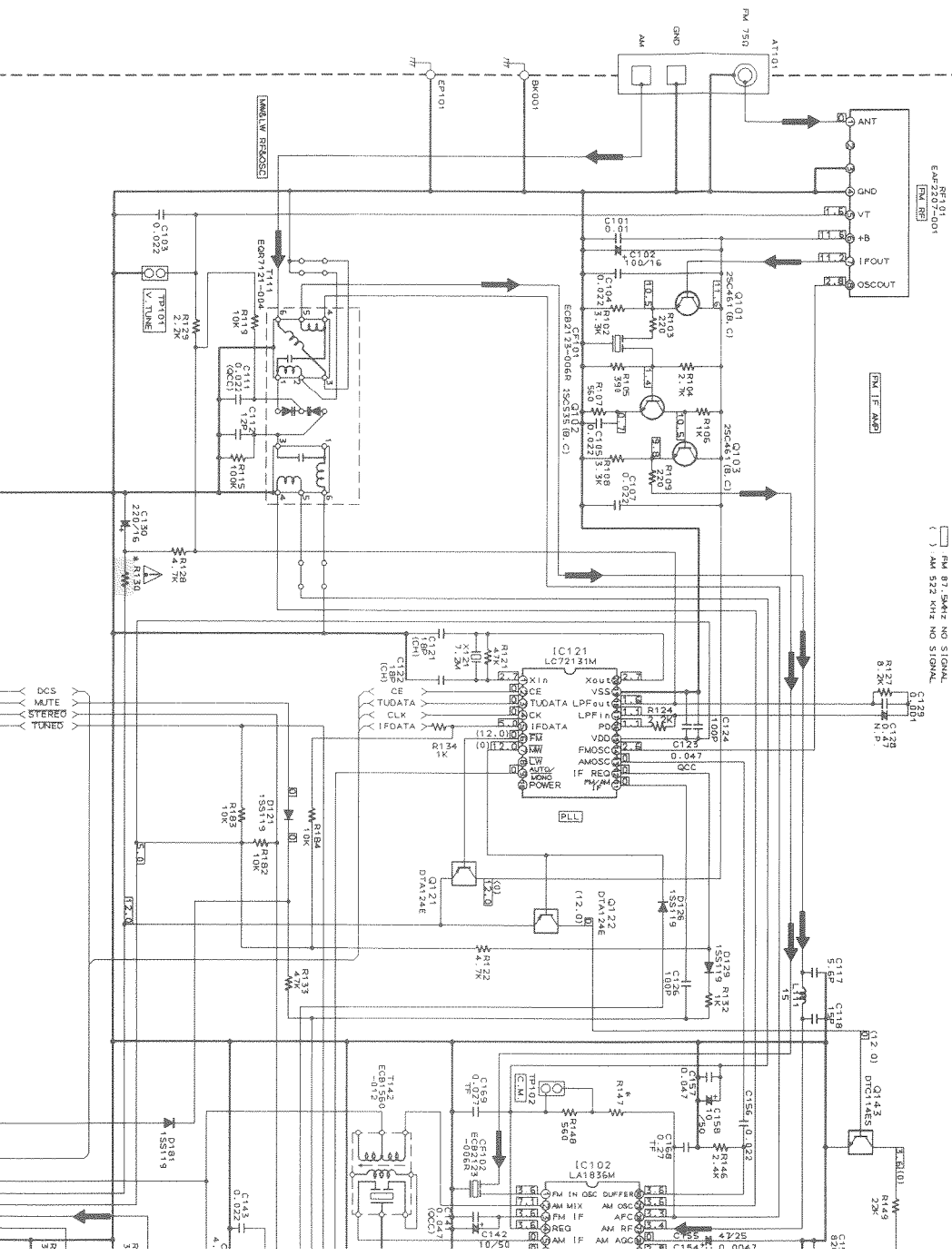
ENA-177-1

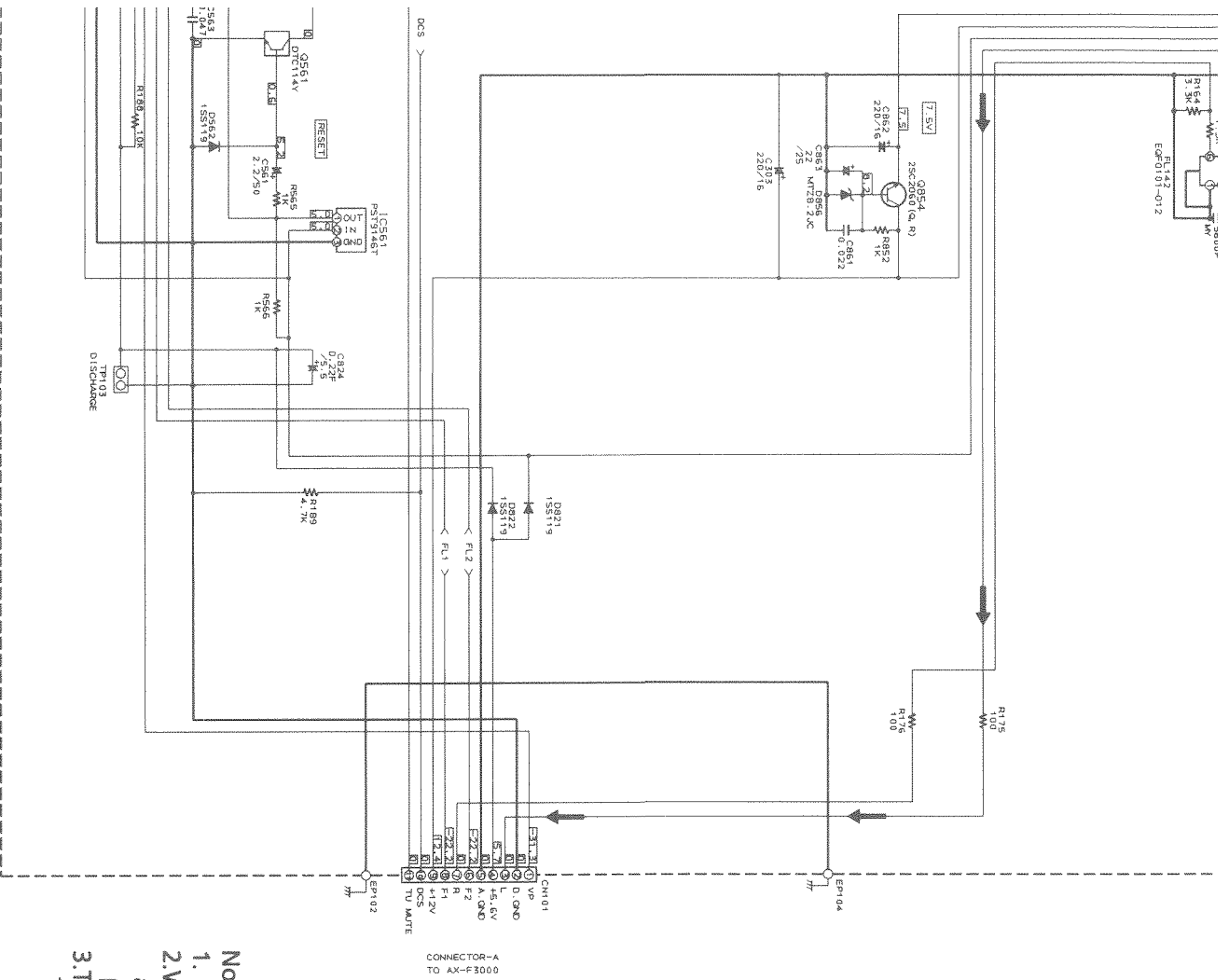



- Notes:
1.  indicates Main signal path.
 2. When replacing the parts in the darkened are () and those marked with , be sure to use the designated parts to ensure safety.
 3. This is the standard circuit diagram. The design and contents are subject to change without notice.

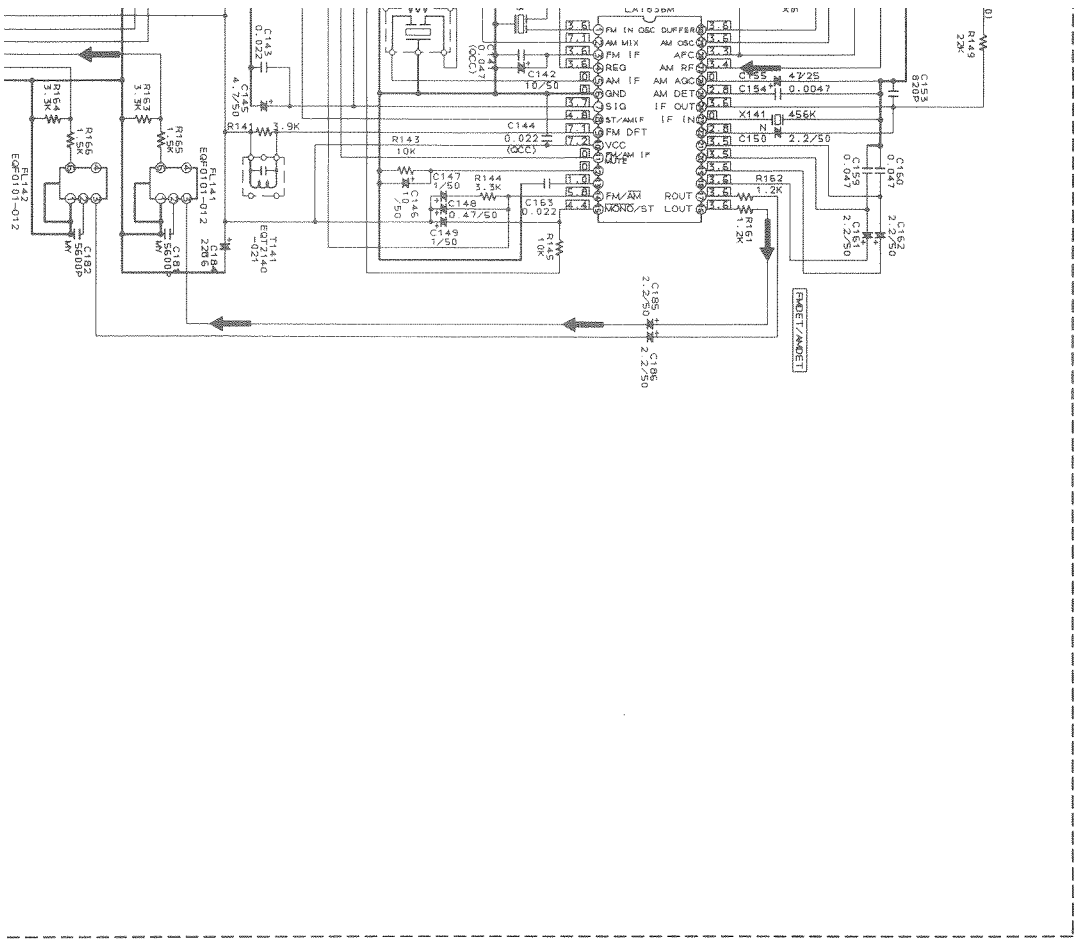

* MARK

UL	UB	US	UT	L-C
R130	68	UNF	F	68
R147	58K	UNF	C	22K
D221	USED	NONE	NONE	NONE
D222	USED	NONE	USED	USED

VERSION CODES

J : U.S.A.
 C : CANADA
 UT : TAIWAN
 UB : HONG KONG
 US : SINGAPORE
 U : UNIVERSAL EXCEPT ALL OF ABOVE

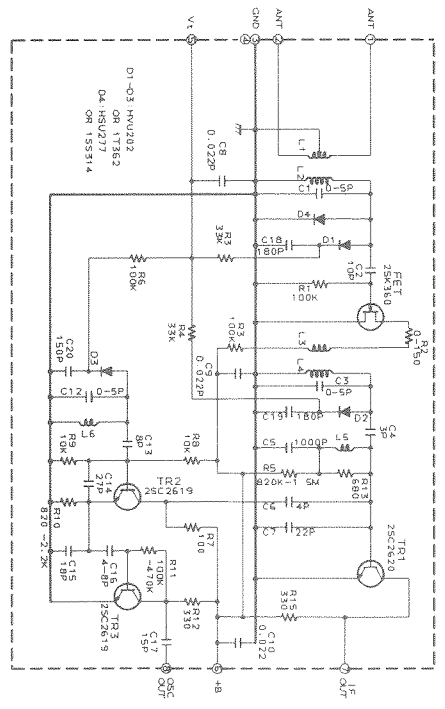

P5-13-a

P5-13-b

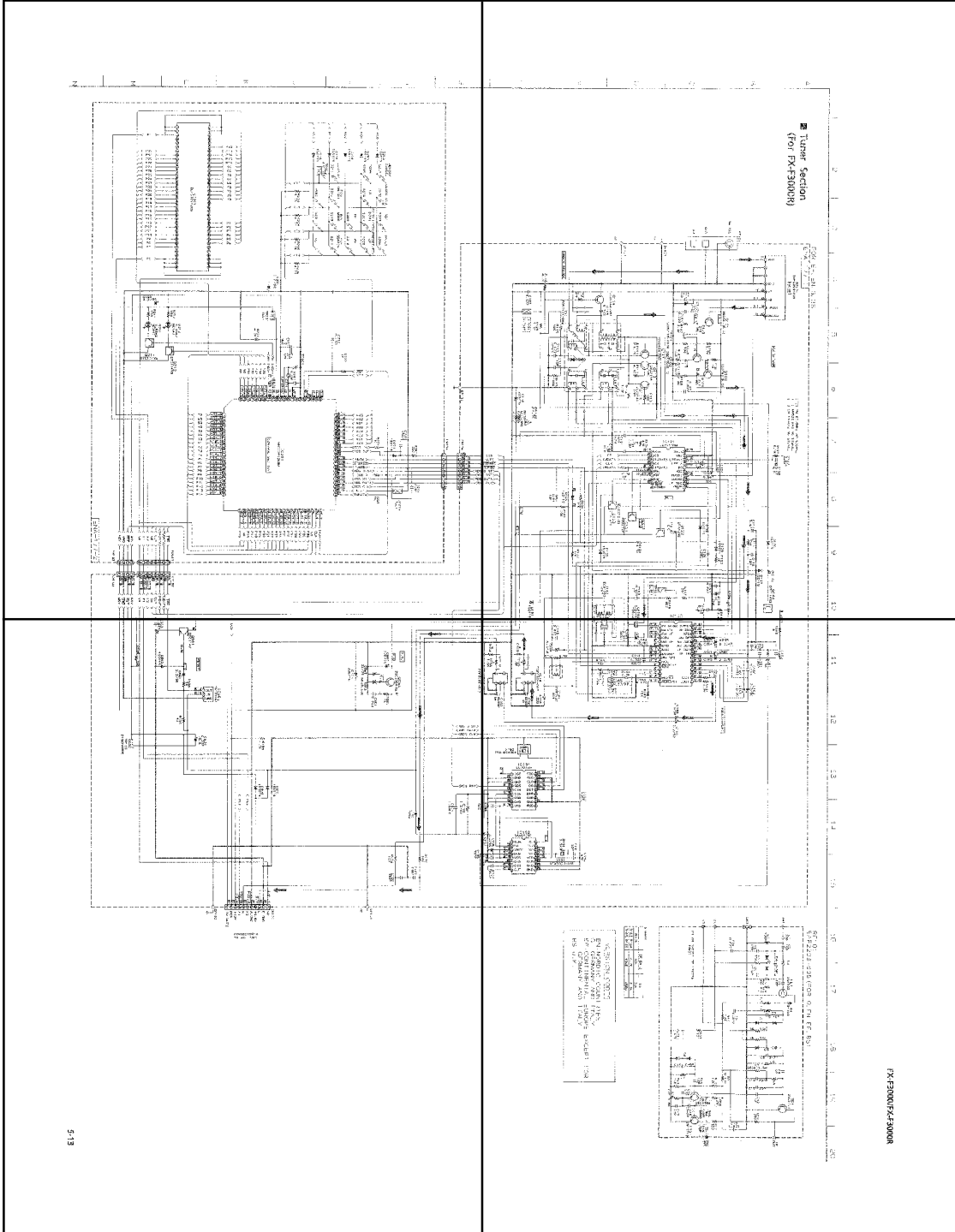

P5-13-c

P5-13-d

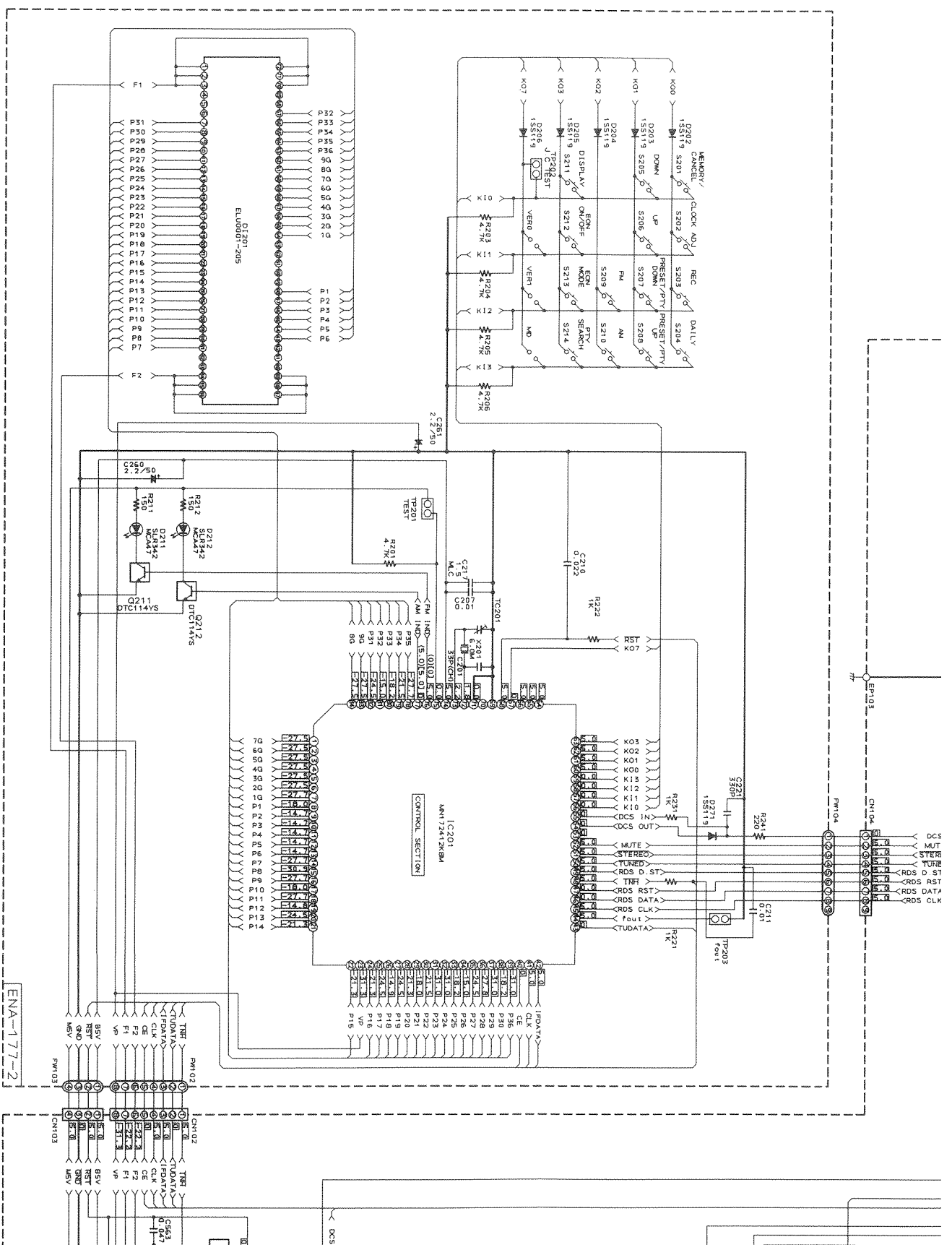

Tuner Section (For FX-F3000R)

FOR EF, EN, G, BS
ENA-177-1

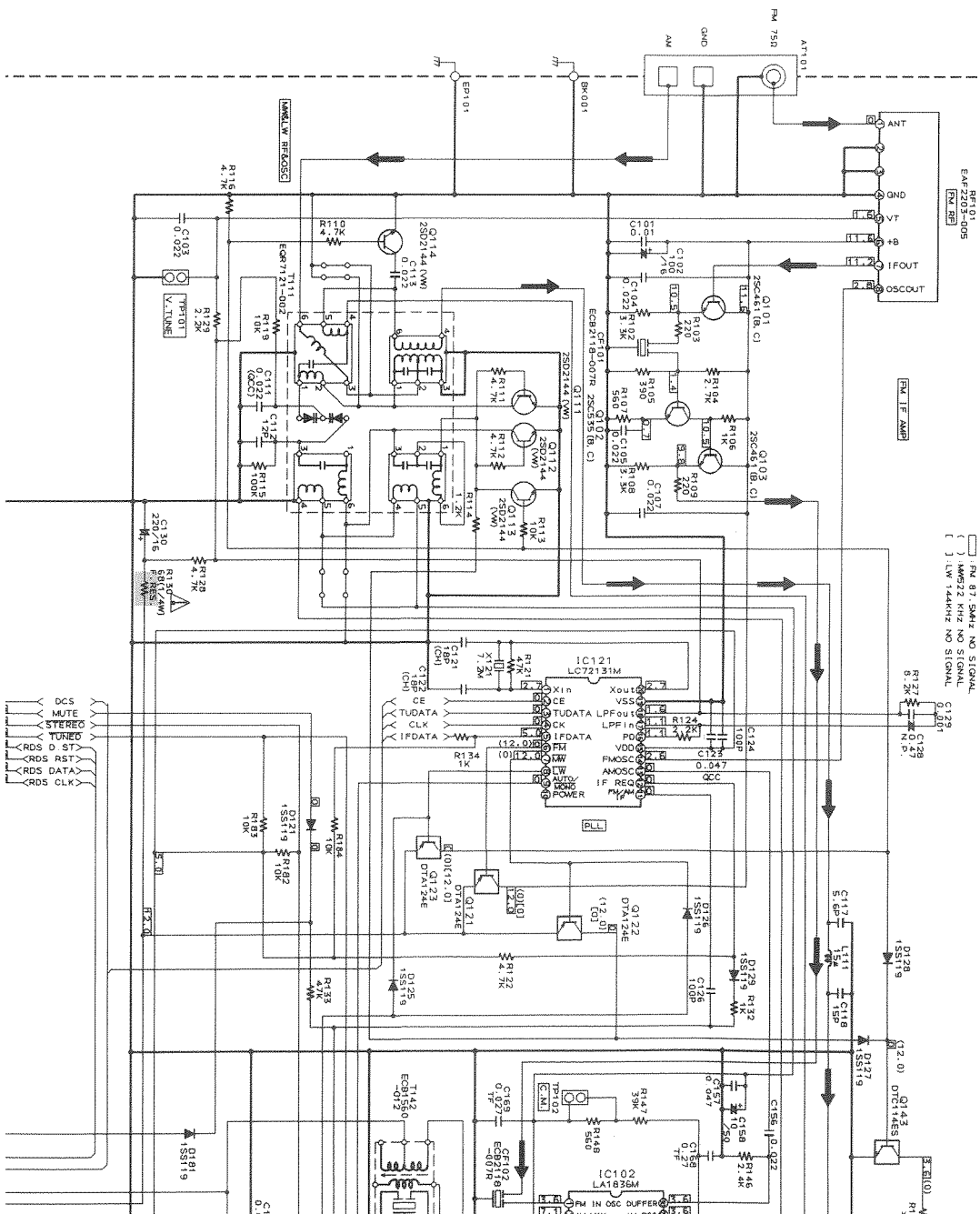

1 2 3 4 5 6 7 8 9 10

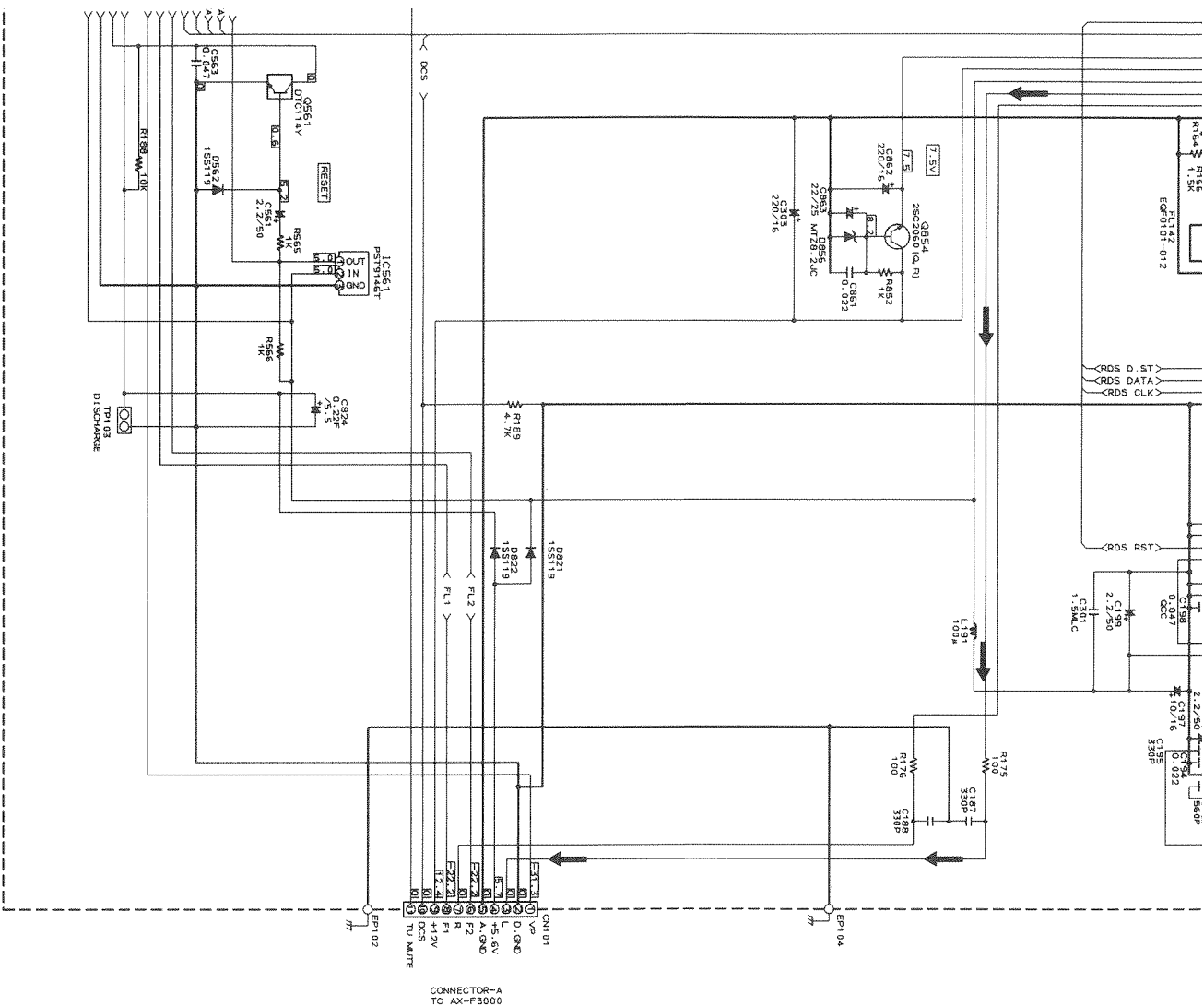

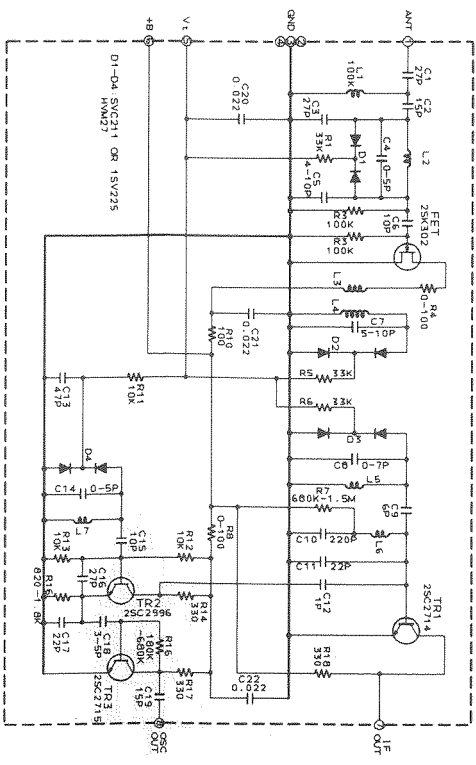
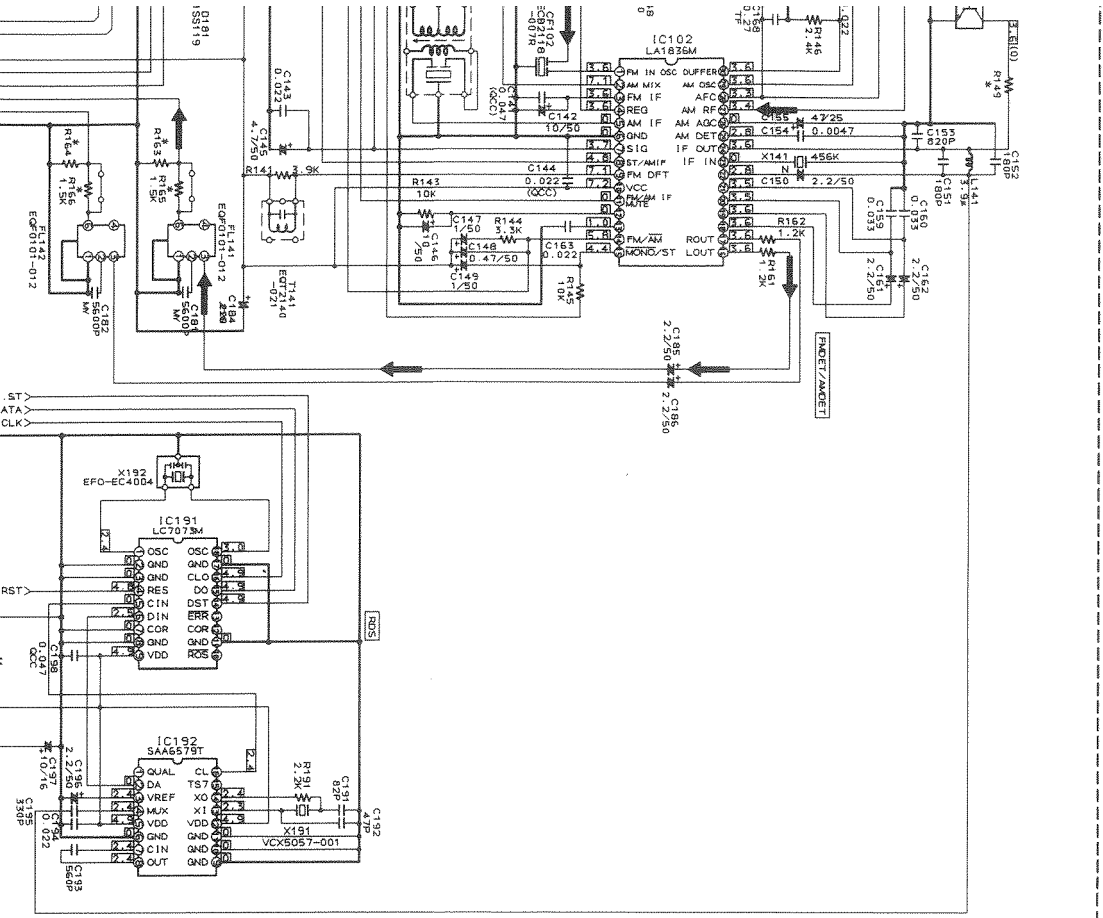

# MARK	EF	EN	G	BS
R148	100K	22K		
R153, R154	4.7K	3.3K		
R155, R156	NONE	USED		

VERSION CODES
 EN: NORDIC COUNTRIES
 G: GERMANY AND ITALY
 EF: CONTINENTAL EUROPE EXCEPT FOR
 GERMANY AND ITALY
 BS: U.K.

PARTS LIST

< AX-F3000 >

* All printed circuit boards and its assemblies are not available as service parts.

The Marks for Designated Areas

BS . . . the U. K.	C . . . Canada	EF . . . Continental Europe	EN . . . Scandinavia
G . . . Germany	J . . . the U. S. A.	UB . . . Hong Kong	U . . . Universal Type
US . . . Singapore	UT . . . Taiwan	No marks indicates all areas.	

- Contents -

General Exploded View and Parts List	6-2
Electrical Parts List	6-4
(ENH-296)	6-4
(ENB-241)	6-7
(END-104)	6-9

AX-F3000

General Exploded View and Parts List

Block No. 

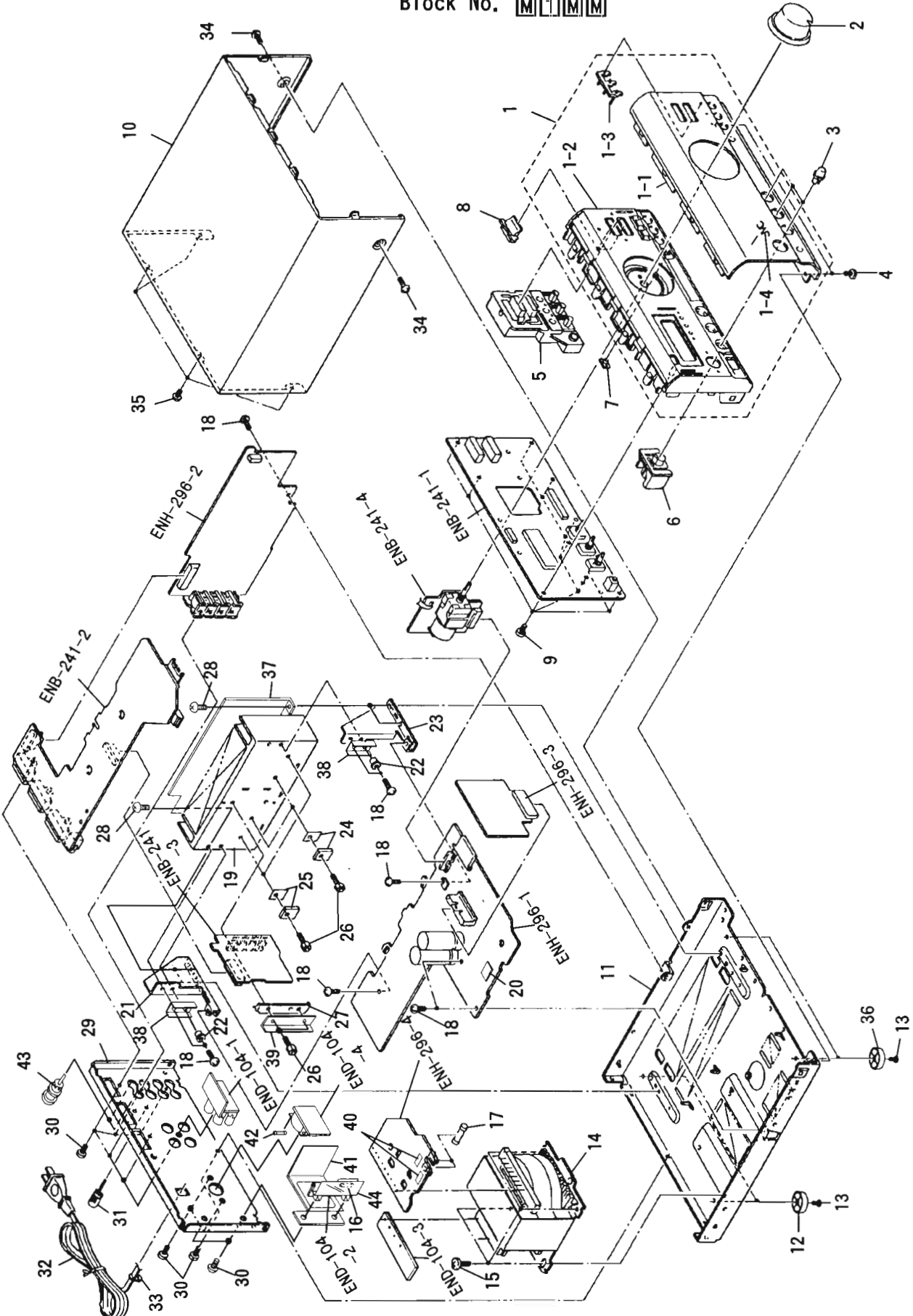

■ Parts List

Block No. 

△	Item	Parts Number	Parts Name	Q'ty	Description	Area
	1	EFP-AXF3000E(S)	FRONT PANEL ASSY	1		
	1-1	E208722-003	FRONT PANEL	1		
	1-2	E103093-002ST	FRONT BASE	1		
	1-3	E408916-001	INDICATOR	1	FUNCTION	
	1-4	E406971-221	JVC MARK	1		
	2	E309630-004SS	VOLUME KNOB	1		
	3	E408127-006	KNOB	3	BASS TREBLE BALANCE	
	4	SDSG3008CC	TAPPING SCREW	2		
	5	E208724-003SS	PUSH BUTTON ASSY	1	SOURCE	
	6	E309627-003SS	PUSH BUTTON ASSY	1	POWER	
	7	E408131-001	REMOCON PLATE	1		
	8	E408915-001	INDICATOR	2	DIRECT	
	9	SDSF2608Z	SCREW	10		
	10	E208174-009(S)	METAL COVER	1		
	11	E102864-001	CHASSIS BASE	1		
	12	E75281-010	FOOT	2		
	13	SBST3010Z	TAPPING SCREW	4		
△	14	ETP1100-63EAJ	POWER TRANSFORMER	1		EF EN G BS
△		ETP1100-63FAJ	POWER TRANSFORMER	1		U UB US UT
△		ETP1100-63JAJ	POWER TRANSFORMER	1		C J
	15	E65389-004	SPECIAL SCREW	4		
△	16	QMF0007-2R5J1	FUSE	1	F001 (T2. 5A/125V)	C J
△		QMF51E2-1R2J1BS	FUSE	1	F001 (T1. 2A/250V)	BS
△		QMF51E2-1R25	FUSE	1	F001 (T1. 25A/250V)	EF EN G
△		QMF51E2-2R5J1	FUSE	1	F001 (2. 5A/250V)	U UB US UT
△	17	QMF0007-1R6J1	FUSE	2	F801 F802 (T1. 6A/125V)	C J
△		QMF51E2-1R2J1BS	FUSE	2	F801 F802 (T1. 2A/250V)	BS
△		QMF51E2-1R25	FUSE	2	F801 F802 (T1. 25A/250V)	EF EN G U UB US UT
	18	SBSG3008CC	TAPPING SCREW	9		
	19	E309632-003SS	HEAT SINK	1		
	20	E3400-431	FELT SPACER	1		BS EF EN G
	21	E308971-001ST	HEAT SINK BRACKET	1		
	22	BUSH-PUL	BUSHING	2		
	23	E308971-002ST	HEAT SINK BRACKET	1		
	24	2SC3853LD(O. Y)	SI. TRANSISTOR	2	Q769 Q770	
	25	2SA1489LD(O. Y)	SI. TRANSISTOR	2	Q771 Q772	
	26	E73525-003	SCREW	6		
	27	E406969-221	LEAF SPRING	1		
	28	SBST3006CC	TAPPING SCREW	4		
	29	E208727-002	REAR PANEL	1		J
		E208727-003	REAR PANEL	1		C
		E208727-004	REAR PANEL	1		BS EF EN G
		E208727-005	REAR PANEL	1		U UB US UT
	30	E73273-003	SPECIAL SCREW	11		U UB US UT
		E73273-003	SPECIAL SCREW	9		Except U UB US UT
	31	E409257-001	EARTH TERMINAL	1		
△	32	QMP1480-200L	POWER CORD	1		C J
△		QMP3900-200	POWER CORD	1		EF EN G US
△		QMP5530-0085BS	POWER CORD	1		BS UB
△		QMP7520-200	POWER CORD	1		U UT
△	33	QHS3771-108	CORD STOPPER	1		
	34	SDSG3008N	TAPPING SCREW	2		
	35	GBSG3008CC	TAPPING SCREW	4		
	36	E75281-009	FOOT	2		
	37	E310161-001	PROTECT SHEET	1		
	38	E70306-001	HEAT SINK	2		
	39	E409510-001SS	HEAT SINK	1		
	40	E61380-032	FUSE LABEL	2		C J
	41	E310128-001SS	PROTECT SHEET	1		U UB US UT
		E409464-001SS	PROTECT SHEET	1		BS C EF EN G J
△	42	QMF51E2-1R25	FUSE	1	F002 (T1. 25A/250V)	U UB US UT
	43	E03449-001	SHORT PLUG	2		
	44	E310127-001SS	PROTECT COVER	1		
	-	E61029-005	NUMBER LABEL	1		
		E75803-001	FUSE C. LABEL	1		J
		E75804-001	FUSE C. LABEL	1		C
		E75139-004	NAME SHEET	1		U
		E309384-027	RATING LABEL	1		UT

AX-F3000

■ Electrical Parts List (ENH-296)

△	Item	Parts Number	Description	Area
		I. C. S		
	IC101	NJM4580DD	I. C (MONO-ANALOG)	
	IC201	TC9164AM	I. C (DIGI-MOS)	
	IC231	NJM4580DD	I. C (MONO-ANALOG)	
	IC301	NJM4580DD	I. C (MONO-ANALOG)	
	IC361	NJM4580DD	I. C (MONO-ANALOG)	
	IC363	NJM4558D	I. C (MONO-ANALOG)	
	IC751	VC5022-2	I. C (MONO-ANALOG)	
	IC752	VC5022-2	I. C (MONO-ANALOG)	
		DIODES		
	D202	1SS119	SI. DIODE	
	D203	1SS119	SI. DIODE	
	D211	MTZ2. 7JB	ZENER DIODE	
	D700	SLR-342MCA47	L. E. D.	
	D711	MTZ2. 7JB	ZENER DIODE	
	D712	MTZ2. 7JB	ZENER DIODE	
	D713	1SS119	SI. DIODE	
	D714	1SS119	SI. DIODE	
	D721	MTZ6. 2JC	ZENER DIODE	
	D751	1SS119	SI. DIODE	
	D752	1SS119	SI. DIODE	
	D791	1SS119	SI. DIODE	
	D792	1SS119	SI. DIODE	
	D793	1SS119	SI. DIODE	
	D794	1SS119	SI. DIODE	
△	D801	30DL2FC	SI. DIODE	
△	D802	30DL2FC	SI. DIODE	
△	D803	30DL2FC	SI. DIODE	
△	D804	30DL2FC	SI. DIODE	
	D901	1SS119	SI. DIODE	
	D902	1SS119	SI. DIODE	
	D905	1SS119	SI. DIODE	
	D912	1SS119	SI. DIODE	
		TRANSISTORS		
	Q251	2SC2389 (S. E)	SI. TRANSISTOR	
	Q353	DTA144ES	DIGITAL TRANSISTOR	
	Q354	DTC144ES	DIGITAL TRANSISTOR	
	Q355	DTA114TS	DIGITAL TRANSISTOR	
	Q357	2SD2144S (VW)	SI. TRANSISTOR	
	Q358	2SD2144S (VW)	SI. TRANSISTOR	
	Q361	2SK301 (P. Q)	F. E. T.	
	Q362	2SK301 (P. Q)	F. E. T.	
	Q524	DTA144ES	DIGITAL TRANSISTOR	
	Q701	2SC2240 (GR. BL)	SI. TRANSISTOR	
	Q702	2SC2240 (GR. BL)	SI. TRANSISTOR	
	Q703	2SC2240 (GR. BL)	SI. TRANSISTOR	
	Q704	2SC2240 (GR. BL)	SI. TRANSISTOR	
	Q705	2SC1775AV (F1)	SI. TRANSISTOR	
	Q706	2SC1775AV (F1)	SI. TRANSISTOR	
	Q707	2SA933LN (R. S)	SI. TRANSISTOR	
	Q708	2SA933LN (R. S)	SI. TRANSISTOR	
	Q709	2SA1207 (S. T)	SI. TRANSISTOR	
	Q710	2SA1207 (S. T)	SI. TRANSISTOR	
	Q711	2SC2909 (S. T)	SI. TRANSISTOR	
	Q712	2SC2909 (S. T)	SI. TRANSISTOR	
	Q713	2SA933LN (R. S)	SI. TRANSISTOR	
	Q714	2SA933LN (R. S)	SI. TRANSISTOR	
	Q751	2SD637 (Q. R)	SI. TRANSISTOR	
	Q752	2SD637 (Q. R)	SI. TRANSISTOR	
	Q761	2SC2240 (GR. BL)	SI. TRANSISTOR	
	Q762	2SC2240 (GR. BL)	SI. TRANSISTOR	
	Q763	2SA970 (GR)	SI. TRANSISTOR	
	Q764	2SA970 (GR)	SI. TRANSISTOR	
	Q765	2SC2235 (O. Y)	SI. TRANSISTOR	
	Q766	2SC2235 (O. Y)	SI. TRANSISTOR	
	Q767	2SA965 (Y)	SI. TRANSISTOR	
	Q768	2SA965 (Y)	SI. TRANSISTOR	
	Q773	2SK170 (BL)	F. E. T.	
	Q774	2SK170 (BL)	F. E. T.	

△	Item	Parts Number	Description	Area
	Q791	2SC1740S (R. S)	SI. TRANSISTOR	
	Q792	2SC1740S (R. S)	SI. TRANSISTOR	
	Q793	2SA933S (RS)	SI. TRANSISTOR	
	Q794	2SA933S (RS)	SI. TRANSISTOR	
	Q901	2SA970 (GR)	SI. TRANSISTOR	
	Q902	2SA970 (GR)	SI. TRANSISTOR	
	Q903	2SC2240 (GR. BL)	SI. TRANSISTOR	
	Q904	2SC3311A (Q. R)	SI. TRANSISTOR	
	Q905	2SA733A (P. K)	SI. TRANSISTOR	
	Q906	2SC2240 (GR. BL)	SI. TRANSISTOR	
	Q921	DTC144ES	DIGITAL TRANSISTOR	
	Q922	DTC114YS	DIGITAL TRANSISTOR	
	Q923	2SA970 (GR)	SI. TRANSISTOR	
	Q931	2SC3311A (Q. R)	SI. TRANSISTOR	
		CAPACITORS		
	C101	QETB1HM-106	10MF 50V E. CAP.	
	C102	QETB1HM-106	10MF 50V E. CAP.	
	C105	QCBB1HK-221Y	220PF 50V CER. CAP.	BS EF EN G
	C106	QCBB1HK-221Y	220PF 50V CER. CAP.	BS EF EN G
	C107	QCBB1HK-471Y	470PF 50V CER. CAP.	BS EF EN G
	C108	QCBB1HK-471Y	470PF 50V CER. CAP.	BS EF EN G
	C111	QETB1HM-106	10MF 50V E. CAP.	
	C112	QETB1HM-106	10MF 50V E. CAP.	
	C113	QFLB1HJ-682	6800PF 50V MYLAR CAP.	
	C114	QFLB1HJ-682	6800PF 50V MYLAR CAP.	
	C115	QFLB1HJ-152	1500PF 50V MYLAR CAP.	
	C116	QFLB1HJ-152	1500PF 50V MYLAR CAP.	
	C117	QCS31HJ-391Z	390PF 50V CER. CAP.	
	C118	QCS31HJ-391Z	390PF 50V CER. CAP.	
	C121	QETB1EM-107	100MF 25V AL E. CAP.	
	C122	QETB1EM-107	100MF 25V AL E. CAP.	
	C123	QETB0JM-107	100MF 6.3V AL E. CAP.	
	C124	QETB0JM-107	100MF 6.3V AL E. CAP.	
	C203	QCS21HJ-101A	100PF 50V CER. CAP.	C J U UB US UT
	C203	QCS31HJ-331Z	330PF 50V CER. CAP.	BS EF EN G
	C204	QCS21HJ-101A	100PF 50V CER. CAP.	C J U UB US UT
	C204	QCS31HJ-331Z	330PF 50V CER. CAP.	BS EF EN G
	C220	QCBB1HK-471Y	470PF 50V CER. CAP.	
	C221	QETB1EM-107	100MF 25V AL E. CAP.	
	C222	QETB1EM-107	100MF 25V AL E. CAP.	
	C231	QETB1HM-106	10MF 50V E. CAP.	
	C232	QETB1HM-106	10MF 50V E. CAP.	
	C233	QCBB1HK-101Y	100PF 50V CER. CAP.	
	C234	QCBB1HK-101Y	100PF 50V CER. CAP.	
	C241	QETB1EM-107	100MF 25V AL E. CAP.	
	C242	QETB1EM-107	100MF 25V AL E. CAP.	
	C251	QETB1HM-106	10MF 50V E. CAP.	
	C261	QFLC1HJ-561Z	560PF 50V MYLAR CAP.	
	C262	QFLC1HJ-561Z	560PF 50V MYLAR CAP.	
	C281	QCBB1HK-221Y	220PF 50V CER. CAP.	BS EF EN G
	C282	QCBB1HK-221Y	220PF 50V CER. CAP.	BS EF EN G
	C301	QCBB1HK-101Y	100PF 50V CER. CAP.	
	C302	QCBB1HK-101Y	100PF 50V CER. CAP.	
	C305	QCSB1HJ-680	68PF 50V CER. CAP.	
	C306	QCSB1HJ-680	68PF 50V CER. CAP.	
	C307	QETB1HM-106	10MF 50V E. CAP.	
	C308	QETB1HM-106	10MF 50V E. CAP.	
	C309	QETB1HM-106	10MF 50V E. CAP.	
	C310	QETB1HM-106	10MF 50V E. CAP.	
	C311	QETB1HM-106	10MF 50V E. CAP.	
	C312	QETB1HM-106	10MF 50V E. CAP.	
	C320	QCGB1HK-102	1000PF 50V CER. CAP.	
	C331	QETB1EM-107	100MF 25V AL E. CAP.	
	C332	QETB1EM-107	100MF 25V AL E. CAP.	
	C345	QETB1EM-106	10MF 25V AL E. CAP.	
	C371	QETB1HM-106	10MF 50V E. CAP.	
	C372	QETB1HM-106	10MF 50V E. CAP.	
	C373	QETB1HM-106	10MF 50V E. CAP.	
	C374	QETB1HM-106	10MF 50V E. CAP.	

■ Electrical Parts List (ENH-296)

△	Item	Parts Number	Description	Area
	C381	QFVB1HJ-474N	0.47MF 50V THIN FILM CA	
	C382	QFVB1HJ-474N	0.47MF 50V THIN FILM CA	
	C383	QFLB1HJ-563	0.056MF 50V MYLAR CAP.	
	C384	QFLB1HJ-563	0.056MF 50V MYLAR CAP.	
	C385	QFLB1HJ-822	8200PF 50V MYLAR CAP.	
	C386	QFLB1HJ-822	8200PF 50V MYLAR CAP.	
	C389	QFLB1HJ-333	0.033MF 50V MYLAR CAP.	
	C390	QFLB1HJ-333	0.033MF 50V MYLAR CAP.	
	C395	QETB1EM-107	100MF 25V AL E. CAP.	
	C396	QETB1EM-107	100MF 25V AL E. CAP.	
	C701	EETB1CM-226E	22MF 16V E. CAP.	
	C702	EETB1CM-226E	22MF 16V E. CAP.	
	C703	QCS21HJ-680A	68PF 50V CER. CAP.	
	C704	QCS21HJ-680A	68PF 50V CER. CAP.	
	C705	QCS21HJ-101A	100PF 50V CER. CAP.	BS EF EN G
	C706	QCS21HJ-101A	100PF 50V CER. CAP.	BS EF EN G
	C709	QFN81HJ-821	820PF 50V MYLAR CAP.	
	C710	QFN81HJ-821	820PF 50V MYLAR CAP.	
	C711	QCS21HJ-100	10PF 50V CER. CAP.	
	C712	QCS21HJ-100	10PF 50V CER. CAP.	
	C713	EETB1CM-226E	22MF 16V E. CAP.	
	C714	EETB1CM-226E	22MF 16V E. CAP.	
	C721	QCS21HJ-220A	22PF 50V CER. CAP.	
	C722	QCS21HJ-220A	22PF 50V CER. CAP.	
	C723	QCS21HJ-680A	68PF 50V CER. CAP.	
	C724	QCS21HJ-680A	68PF 50V CER. CAP.	
	C725	QCS21HJ-680A	68PF 50V CER. CAP.	
	C726	QCS21HJ-680A	68PF 50V CER. CAP.	
	C727	QFN31HJ-103Z	0.01MF 50V MYLAR CAP.	
	C728	QFN31HJ-103Z	0.01MF 50V MYLAR CAP.	
	C761	QFP81HJ-680	68PF 50V POLYPROPY. F I	
	C762	QFP81HJ-680	68PF 50V POLYPROPY. F I	
	C763	QFP81HJ-680	68PF 50V POLYPROPY. F I	
	C764	QFP81HJ-680	68PF 50V POLYPROPY. F I	
	C773	QFN31HJ-473ZN	0.047MF 50V MYLAR CAP.	
	C774	QFN31HJ-473ZN	0.047MF 50V MYLAR CAP.	
	C781	QFVC1HJ-104ZN	0.1MF 50V METAL. MYLAR	
	C782	QFVC1HJ-104ZN	0.1MF 50V METAL. MYLAR	
	C783	QFVC1HJ-104ZN	0.1MF 50V METAL. MYLAR	
	C784	QFVC1HJ-104ZN	0.1MF 50V METAL. MYLAR	
	C801	EEW5009-828E	8200MF E. CAP.	
	C802	EEW5009-828E	8200MF E. CAP.	
	C811	EETB1HM-227E	220MF 50V AL E. CAP.	
	C812	EETB1HM-227E	220MF 50V AL E. CAP.	
	C843	QFN82AJ-104	0.1MF 100V MYLAR CAP.	
	C844	QFN82AJ-104	0.1MF 100V MYLAR CAP.	
	C845	QFN82AJ-104	0.1MF 100V MYLAR CAP.	
	C846	QFN82AJ-104	0.1MF 100V MYLAR CAP.	
	C901	QETB1HM-105	1MF 50V AL E. CAP.	
	C903	QETB1HM-226E	22MF 50V E. CAP.	
	C904	QETB1CM-476	47MF 16V AL E. CAP.	
	C955	QCS31HJ-471Z	470PF 50V CER. CAP.	BS EF EN G
		RESISTORS		
	R101	QRD161J-471	470 1/6W CARBON RES.	
	R102	QRD161J-471	470 1/6W CARBON RES.	
	R103	QRD161J-473	47K 1/6W CARBON RES.	
	R104	QRD161J-473	47K 1/6W CARBON RES.	
	R105	QRD161J-474	470K 1/6W CARBON RES.	
	R106	QRD161J-474	470K 1/6W CARBON RES.	
	R107	QRD161J-393	39K 1/6W CARBON RES.	
	R108	QRD161J-393	39K 1/6W CARBON RES.	
	R109	QRD167J-511	510 1/6W CARBON RES.	
	R110	QRD167J-511	510 1/6W CARBON RES.	
	R111	QRD161J-101	100 1/6W CARBON RES.	
	R112	QRD161J-101	100 1/6W CARBON RES.	
	R113	QRD161J-104	100K 1/6W CARBON RES.	
	R114	QRD161J-104	100K 1/6W CARBON RES.	
	R121	QRD161J-101	100 1/6W CARBON RES.	
	R122	QRD161J-101	100 1/6W CARBON RES.	

△	Item	Parts Number	Description	Area
	R201	QRD161J-222	2.2K 1/6W CARBON RES.	
	R202	QRD161J-222	2.2K 1/6W CARBON RES.	
	R203	QRD161J-273	27K 1/6W CARBON RES.	
	R204	QRD161J-273	27K 1/6W CARBON RES.	
	R211	QRD161J-913	91K 1/6W CARBON RES.	
	R212	QRD161J-913	91K 1/6W CARBON RES.	
	R213	QRD161J-303Y	30K 1/6W CARBON RES.	
	R214	QRD161J-303Y	30K 1/6W CARBON RES.	
	R217	QRD161J-331	330 1/6W CARBON RES.	
	R218	QRD161J-331	330 1/6W CARBON RES.	
	R221	QRD161J-331	330 1/6W CARBON RES.	
	R222	QRD161J-331	330 1/6W CARBON RES.	
	R231	QRD161J-123	12K 1/6W CARBON RES.	
	R232	QRD161J-123	12K 1/6W CARBON RES.	
	R235	QRD161J-104	100K 1/6W CARBON RES.	
	R236	QRD161J-104	100K 1/6W CARBON RES.	
	R241	QRD14CJ-331SX	330 1/4W UNF. CARBON R	
	R242	QRD14CJ-331SX	330 1/4W UNF. CARBON R	
	R255	QRD167J-223	22K 1/6W CARBON RES.	
	R256	QRD161J-333	33K 1/6W CARBON RES.	
	R261	QRD161J-103	10K 1/6W CARBON RES.	
	R262	QRD161J-103	10K 1/6W CARBON RES.	
	R263	QRD161J-103	10K 1/6W CARBON RES.	
	R264	QRD161J-103	10K 1/6W CARBON RES.	
	R265	QRD161J-104	100K 1/6W CARBON RES.	
	R266	QRD161J-104	100K 1/6W CARBON RES.	
	R301	QRD161J-123	12K 1/6W CARBON RES.	
	R302	QRD161J-123	12K 1/6W CARBON RES.	
	R305	QRD161J-123	12K 1/6W CARBON RES.	
	R306	QRD161J-123	12K 1/6W CARBON RES.	
	R331	QRD14CJ-331SX	330 1/4W UNF. CARBON R	
	R332	QRD14CJ-331SX	330 1/4W UNF. CARBON R	
	R343	QRD161J-105	1M 1/6W CARBON RES.	
	R344	QRD161J-102	1K 1/6W CARBON RES.	
	R345	QRD161J-104	100K 1/6W CARBON RES.	
	R357	QRD161J-103	10K 1/6W CARBON RES.	
	R358	QRD161J-103	10K 1/6W CARBON RES.	
	R371	QRD161J-101	100 1/6W CARBON RES.	
	R372	QRD161J-101	100 1/6W CARBON RES.	
	R373	QRD161J-104	100K 1/6W CARBON RES.	
	R374	QRD161J-104	100K 1/6W CARBON RES.	
	R375	QRD167J-223	22K 1/6W CARBON RES.	
	R376	QRD167J-223	22K 1/6W CARBON RES.	
	R381	QRD167J-332	3.3K 1/6W CARBON RES.	
	R382	QRD167J-332	3.3K 1/6W CARBON RES.	
	R383	QRD167J-332	3.3K 1/6W CARBON RES.	
	R384	QRD167J-332	3.3K 1/6W CARBON RES.	
	R385	QRD161J-392	3.9K 1/6W CARBON RES.	
	R386	QRD161J-392	3.9K 1/6W CARBON RES.	
	R389	QRD161J-103	10K 1/6W CARBON RES.	
	R390	QRD161J-103	10K 1/6W CARBON RES.	
	R391	QRD161J-474	470K 1/6W CARBON RES.	
	R392	QRD161J-474	470K 1/6W CARBON RES.	
	R393	QRD161J-391	390 1/6W CARBON RES.	
	R394	QRD161J-391	390 1/6W CARBON RES.	
△	R395	QRD14CJ-101S	100 1/4W UNF. CARBON R	
△	R396	QRD14CJ-101S	100 1/4W UNF. CARBON R	
	R522	QRD161J-104	100K 1/6W CARBON RES.	
	R523	QRD161J-475	4.7M 1/6W CARBON RES.	
	R524	QRD161J-475	4.7M 1/6W CARBON RES.	
	R527	QRD161J-105	1M 1/6W CARBON RES.	
	R528	QRD161J-105	1M 1/6W CARBON RES.	
	R701	ERD004J-221Z	220 CARBON RES.	
	R702	ERD004J-221Z	220 CARBON RES.	
	R703	ERD004J-104	100K CARBON RES.	
	R704	ERD004J-104	100K CARBON RES.	
△	R705	QRD14CJ-101S	100 1/4W UNF. CARBON R	
△	R706	QRD14CJ-101S	100 1/4W UNF. CARBON R	
	R707	QRD14CJ-121SX	120 1/4W UNF. CARBON R	

AX-F3000

■ Electrical Parts List (ENH-296)

△	Item	Parts Number	Description	Area
	R708	QRD14CJ-121SX	120 1/4W UNF. CARBON R	
	R709	QRD161J-101	100 1/6W CARBON RES.	
	R710	QRD161J-101	100 1/6W CARBON RES.	
	R711	ERD004J-104	100K CARBON RES.	
	R712	ERD004J-104	100K CARBON RES.	
	R713	ERD004J-182Z	1.8K CARBON RES.	
	R714	ERD004J-182Z	1.8K CARBON RES.	
△	R715	QRV144F-2201A	2.2K 1/4W CONST. METAL	
△	R716	QRV144F-2201A	2.2K 1/4W CONST. METAL	
△	R717	QRV144F-2701	2.7K 1/4W CONST. METAL	
△	R718	QRV144F-2701	2.7K 1/4W CONST. METAL	
△	R719	QRV144F-2702	27K 1/4W CONST. METAL	
△	R723	QRD14CJ-471SX	470 1/4W UNF. CARBON R	
△	R724	QRD14CJ-471SX	470 1/4W UNF. CARBON R	
△	R725	QRD14CJ-560S	56 1/4W UNF. CARBON R	
△	R726	QRD14CJ-560S	56 1/4W UNF. CARBON R	
	R727	QRD161J-332	3.3K 1/6W CARBON RES.	
	R728	QRD161J-332	3.3K 1/6W CARBON RES.	
	R729	QRD14CJ-331SX	330 1/4W UNF. CARBON R	
	R730	QRD14CJ-331SX	330 1/4W UNF. CARBON R	
△	R731	QRV144F-2702	27K 1/4W CONST. METAL	
△	R732	QRV144F-2702	27K 1/4W CONST. METAL	
△	R735	QRD14CJ-221S	220 1/4W UNF. CARBON R	
△	R736	QRD14CJ-221S	220 1/4W UNF. CARBON R	
△	R737	QRD14CJ-101S	100 1/4W UNF. CARBON R	
△	R738	QRD14CJ-101S	100 1/4W UNF. CARBON R	
	R751	QVPE601-501	500 0.15WTRIMMER RES.	
	R752	QVPE601-501	500 0.15WTRIMMER RES.	
	R755	ERT-D2WFL351S	350 1/4W NEGATIVE THE	
	R756	ERT-D2WFL351S	350 1/4W NEGATIVE THE	
	R757	QRD161J-101	100 1/6W CARBON RES.	
	R758	QRD161J-101	100 1/6W CARBON RES.	
	R759	QRD161J-471	470 1/6W CARBON RES.	
	R760	QRD161J-471	470 1/6W CARBON RES.	
	R761	QRD161J-391	390 1/6W CARBON RES.	
	R762	QRD161J-391	390 1/6W CARBON RES.	
△	R763	QRD14CJ-122SX	1.2K 1/4W UNF. CARBON R	
△	R764	QRD14CJ-122SX	1.2K 1/4W UNF. CARBON R	
△	R765	QRD14CJ-101S	100 1/4W UNF. CARBON R	
△	R766	QRD14CJ-101S	100 1/4W UNF. CARBON R	
	R767	QRD14CJ-4R7SX	4.7 1/4W UNF. CARBON R	
	R768	QRD14CJ-4R7SX	4.7 1/4W UNF. CARBON R	
	R769	QRD14CJ-4R7SX	4.7 1/4W UNF. CARBON R	
	R770	QRD14CJ-4R7SX	4.7 1/4W UNF. CARBON R	
△	R771	ERF032K-R22	0.22 3W CEM. RES.	
△	R772	ERF032K-R22	0.22 3W CEM. RES.	
△	R777	QRD14CJ-470SX	47 1/4W UNF. CARBON R	
△	R778	QRD14CJ-470SX	47 1/4W UNF. CARBON R	
△	R779	QRD14CJ-470SX	47 1/4W UNF. CARBON R	
△	R780	QRD14CJ-470SX	47 1/4W UNF. CARBON R	
△	R781	QRD125J-100	10 1/2W UNF. CARBON R	
△	R782	QRD125J-100	10 1/2W UNF. CARBON R	
△	R783	QRG022J-100A	10 2W OXIDE METAL	
△	R784	QRG022J-100A	10 2W OXIDE METAL	
	R785	QRG01DJ-821X	820 1W OXIDE METAL	
	R786	QRG01DJ-821X	820 1W OXIDE METAL	
△	R789	QRD14CJ-471SX	470 1/4W UNF. CARBON R	
△	R790	QRD14CJ-471SX	470 1/4W UNF. CARBON R	
△	R791	QRD14CJ-471SX	470 1/4W UNF. CARBON R	
△	R792	QRD14CJ-471SX	470 1/4W UNF. CARBON R	
△	R793	QRD14CJ-471SX	470 1/4W UNF. CARBON R	
△	R794	QRD14CJ-471SX	470 1/4W UNF. CARBON R	
	R795	QRD14CJ-331SX	330 1/4W UNF. CARBON R	
	R796	QRD14CJ-331SX	330 1/4W UNF. CARBON R	
	R797	QRD14CJ-331SX	330 1/4W UNF. CARBON R	
	R798	QRD14CJ-331SX	330 1/4W UNF. CARBON R	
△	R811	QRD14CJ-330SX	33 1/4W UNF. CARBON R	
△	R812	QRD14CJ-330SX	33 1/4W UNF. CARBON R	
	R901	QRD161J-104	100K 1/6W CARBON RES.	

△	Item	Parts Number	Description	Area
	R902	QRD161J-823	82K 1/6W CARBON RES.	
	R903	QRD161J-272	2.7K 1/6W CARBON RES.	
	R904	QRD161J-272	2.7K 1/6W CARBON RES.	
	R905	QRD161J-153	15K 1/6W CARBON RES.	
	R906	QRD161J-153	15K 1/6W CARBON RES.	
	R907	QRD161J-223	22K 1/6W CARBON RES.	
	R908	QRD161J-223	22K 1/6W CARBON RES.	
	R909	QRD161J-103	10K 1/6W CARBON RES.	
	R910	QRD161J-332	3.3K 1/6W CARBON RES.	
	R911	QRD161J-103	10K 1/6W CARBON RES.	
	R912	QRD161J-473	47K 1/6W CARBON RES.	
	R913	QRD161J-103	10K 1/6W CARBON RES.	
	R914	QRD161J-104	100K 1/6W CARBON RES.	
	R915	QRD161J-473	47K 1/6W CARBON RES.	
	R916	QRD161J-103	10K 1/6W CARBON RES.	
	R917	QRD161J-222	2.2K 1/6W CARBON RES.	
	R921	QRD161J-563	56K 1/6W CARBON RES.	
	R922	QRD161J-473	47K 1/6W CARBON RES.	
	R924	QRD161J-103	10K 1/6W CARBON RES.	
	R931	QRG01DJ-471X	470 1W OXIDE METAL	BS EF EN G U UB US UT
△	R931	QRG022J-391A	390 2W OXIDE METAL	C J
	R933	QRD161J-222	2.2K 1/6W CARBON RES.	
		OTHERS		
		EMW10582-102	PRINTED BOARD	
		E61380-032	FUSE LABEL	C
		E61380-032	FUSE LABEL	J
	J201	EMN00TV-406B	PIN JACK	
	J202	EMN00TV-406A	JACK BOARD ASSY	
	L781	EQL0001-1R0	INDUCTOR	
	L782	EQL0001-1R0	INDUCTOR	
	S510	ESP0001-023M	TACT SWITCH	
	CN001	EWS284-004	SOCKET WIRE ASSY	
	CN201	EMV7145-005Z	SOCKET ASSY	
	CN202	EMV5109-006B	CONNECT TERMINAL	
	CN203	EMV5109-003B	CONNECT TERMINAL	
	CN212	EWS296-1916	SOCKET WIRE ASSY	
	CN606	VMC0107-R06	MALE CONNECTOR	
	CN614	EMV5163-012R	CONNECT TERMINAL	
	CN701	EMV5140-015	CONNECT TERMINAL	
	CN711	EMV7140-L15R	CONNECT TERMINAL	
	CN901	EMV7167-026R	CONNECT TERMINAL	
	CN902	EMV7163-010	CONNECT TERMINAL	
	EP200	EMZ4002-002Z	EARTH PLATE	
	EP300	EMZ4002-002Z	EARTH PLATE	
	FS705	E3400-431	FELT SPACER	BS EF EN G
	FS706	E3400-431	FELT SPACER	BS EF EN G
	FS707	E3400-431	FELT SPACER	BS EF EN G
	FS708	E3400-431	FELT SPACER	BS EF EN G
	FT801	EMG7331-003Z	FUSE CLIP	
	FT802	EMG7331-003Z	FUSE CLIP	
	FT811	EMG7331-003Z	FUSE CLIP	
	FT812	EMG7331-003Z	FUSE CLIP	
	RY251	ESK5D24-21AF	RELAY	
	RY901	ESK7D24-2120	RELAY	

■ Electrical Parts List (ENB-241)

△	Item	Parts Number	Description	Area
		I. C. S		
	IC351	LB1639-CV	I. C (DIGI-OTHER)	
	IC501	MN171202K8N	I. C (MICRO-COMPUTER)	
	IC502	NJH32H380A	I. C (M)	
		DIODES		
	D355	1SR139-200	SI. DIODE	
	D504	1SS119	SI. DIODE	
	D505	1SS119	SI. DIODE	
	D506	1SS119	SI. DIODE	
	D507	1SS119	SI. DIODE	
	D508	SLR-342MCA47	L. E. D.	
	D509	SLR-342MCA47	L. E. D.	
	D510	SLR-342MCA47	L. E. D.	
	D511	SLR-342MCA47	L. E. D.	
	D512	SLR-342MCA47	L. E. D.	
	D513	SLR-342MCA47	L. E. D.	
	D514	SLA-380LT	L. E. D.	BS
	D514	SLR-342VC3F	L. E. D.	C EF EN G J U UB US UT
	D515	SLR-342VC3F	L. E. D.	
	D516	SLR-342VC3F	L. E. D.	
	D517	SLR-342VC3F	L. E. D.	
	D518	SLR-342VC3F	L. E. D.	
	D519	SLR-342VC3F	L. E. D.	
	D520	SLR-342VC3F	L. E. D.	
△	D611	11E2	SI. DIODE	
△	D612	11E2	SI. DIODE	
△	D613	11E2	SI. DIODE	
△	D614	11E2	SI. DIODE	
	D615	1SR139-200	SI. DIODE	
	D616	1SR139-200	SI. DIODE	
	D617	1SR139-200	SI. DIODE	
	D621	1SS119	SI. DIODE	
	D622	1SS119	SI. DIODE	
	D623	MTZ5. 1JB	ZENER DIODE	
	D624	1SR139-200	SI. DIODE	
	D625	1SR139-200	SI. DIODE	
	D626	MTZ33JC	ZENER DIODE	
	D627	MTZ8. 2JC	ZENER DIODE	
	D629	1SS119	SI. DIODE	
	D630	1SS119	SI. DIODE	
	D631	1SS119	SI. DIODE	
	D651	MTZ5. 1JAT-77	ZENER DIODE	
	D653	MTZ5. 6JC	ZENER DIODE	
	D654	MTZ6. 8JC	ZENER DIODE	
	D655	MTZ6. 8JC	ZENER DIODE	
		TRANSISTORS		
	Q351	2SC2878 (B)	SI. TRANSISTOR	
	Q352	2SC2878 (B)	SI. TRANSISTOR	
	Q503	DTC114YS	DIGITAL TRANSISTOR	
	Q522	DTC114YS	DIGITAL TRANSISTOR	
	Q523	DTC114YS	DIGITAL TRANSISTOR	
	Q524	DTA144ES	DIGITAL TRANSISTOR	
	Q525	DTC144ES	DIGITAL TRANSISTOR	
	Q621	DTC114YS	DIGITAL TRANSISTOR	
	Q622	DTC144ES	DIGITAL TRANSISTOR	
	Q623	2SB1357 (E, F)	SI. TRANSISTOR	
	Q624	2SD2037 (E, F)	SI. TRANSISTOR	
	Q651	2SD2061 (F, G)	SI. TRANSISTOR	
	Q652	2SC1740S (R, S)	SI. TRANSISTOR	
	Q653	2SC1740S (R, S)	SI. TRANSISTOR	
△	Q654	2SD2394 (E, F)	SI. TRANSISTOR	
	Q655	2SC1740S (R, S)	SI. TRANSISTOR	
	Q656	2SC1740S (R, S)	SI. TRANSISTOR	
△	Q657	2SD2394 (E, F)	SI. TRANSISTOR	
	Q658	2SC1775AV (F1)	SI. TRANSISTOR	
	Q659	2SC1740S (R, S)	SI. TRANSISTOR	
	Q660	2SC1740S (R, S)	SI. TRANSISTOR	
	Q661	2SB1565 (E, F)	SI. TRANSISTOR	

△	Item	Parts Number	Description	Area
	Q662	2SA872AV (E, F)	SI. TRANSISTOR	
	Q663	2SA933LN (R, S)	SI. TRANSISTOR	
	Q664	2SA933LN (R, S)	SI. TRANSISTOR	
	Q665	DTA144ES	DIGITAL TRANSISTOR	
	Q666	DTC144ES	DIGITAL TRANSISTOR	
	Q667	DTC144ES	DIGITAL TRANSISTOR	
	Q668	DTA144ES	DIGITAL TRANSISTOR	
		CAPACITORS		
	C313	QFN81HJ-153	0. 015MF 50V MYLAR CAP.	
	C314	QFN81HJ-153	0. 015MF 50V MYLAR CAP.	
	C315	QFVB1HJ-124N	0. 12MF 50V THIN FILM CA	
	C316	QFVB1HJ-124N	0. 12MF 50V THIN FILM CA	
	C317	QFVB1HJ-124N	0. 12MF 50V THIN FILM CA	
	C318	QFVB1HJ-124N	0. 12MF 50V THIN FILM CA	
	C355	QETB1AM-476	47MF 10V E. CAP.	
	C356	QCHB1EZ-223	0. 022MF 25V CER. CAP.	
	C501	QCVB1CM-103Y	0. 01MF 16V CER. CAP.	
	C502	QCHB1EZ-223	0. 022MF 25V CER. CAP.	
	C503	QETB1HM-225	2. 2MF 50V AL. E. CAP.	
	C504	QCVB1CM-103Y	0. 01MF 16V CER. CAP.	
	C505	EEZ0601-108	1000MF AL. E. CAP.	
	C506	QEK50JM-476	47MF 6. 3V AL. E. CAP.	
	C507	QETB1AM-227	220MF 10V E. CAP.	
	C508	QCB1HK-471Y	470PF 50V CER. CAP.	
	C521	QETB1CM-226	22MF 16V E. CAP.	
	C611	EET3513-228	2200MF ELECTRO	
	C612	EET3513-228	2200MF ELECTRO	
	C613	EET3513-228	2200MF ELECTRO	
	C616	QFN82AJ-104	0. 1MF 100V MYLAR CAP.	
	C621	QETB1HM-105	1MF 50V AL. E. CAP.	
	C622	QETB1HM-227	220MF 50V E. CAP.	
	C623	QETB1HM-227	220MF 50V E. CAP.	
	C624	QETB1HM-226E	22MF 50V E. CAP.	
	C625	QETB1HM-226E	22MF 50V E. CAP.	
	C626	QETB1HM-475E	4. 7MF 50V E. CAP.	
	C627	QETB1HM-475E	4. 7MF 50V E. CAP.	
	C651	QCVB1CM-103Y	0. 01MF 16V CER. CAP.	
	C652	QETB1CM-226	22MF 16V E. CAP.	
	C653	QETB1CM-226	22MF 16V E. CAP.	
	C654	QCVB1CM-103Y	0. 01MF 16V CER. CAP.	
	C655	QETB1CM-226	22MF 16V E. CAP.	
	C656	QETB1CM-226	22MF 16V E. CAP.	
	C657	QFLB1HJ-103	0. 01MF 50V MYLAR CAP.	
	C658	QETB1CM-226	22MF 16V E. CAP.	
	C659	QETB1CM-226	22MF 16V E. CAP.	
	C660	QFLB1HJ-103	0. 01MF 50V MYLAR CAP.	
	C661	QETB1CM-226	22MF 16V E. CAP.	
	C662	QETB1CM-226	22MF 16V E. CAP.	
	C951	QCB1HK-561Y	560PF 50V CER. CAP.	BS EF EN G
	C952	QCB1HK-561Y	560PF 50V CER. CAP.	BS EF EN G
	C953	QCS31HJ-471Z	470PF 50V CER. CAP.	BS EF EN G
	C961	QCS21HJ-101A	100PF 50V CER. CAP.	
		RESISTORS		
	R307	QRD161J-392	3. 9K 1/6W CARBON RES.	
	R308	QRD161J-392	3. 9K 1/6W CARBON RES.	
	R309	QRD161J-132	1. 3K 1/6W CARBON RES.	
	R310	QRD161J-132	1. 3K 1/6W CARBON RES.	
	R311	QRD161J-132	1. 3K 1/6W CARBON RES.	
	R312	QRD161J-132	1. 3K 1/6W CARBON RES.	
	R313	QRD161J-392	3. 9K 1/6W CARBON RES.	
	R314	QRD161J-392	3. 9K 1/6W CARBON RES.	
	R341	QRD161J-472	4. 7K 1/6W CARBON RES.	
	R342	QRD161J-472	4. 7K 1/6W CARBON RES.	
	R350	QRD161J-221	220 1/6W CARBON RES.	
	R351	ERD004J-471	470 NETWORK RES.	
	R352	ERD004J-471	470 NETWORK RES.	
	R501	QRD167J-751	750 1/6W CARBON RES.	
	R502	QRD167J-751	750 1/6W CARBON RES.	
	R508	QRD167J-223	22K 1/6W CARBON RES.	

AX-F3000

■ Electrical Parts List (ENB-241)

△	Item	Parts Number	Description	Area
	R509	QRD167J-560	56 1/6W CARBON RES.	
	R510	QRD161J-221	220 1/6W CARBON RES.	
	R511	QRD161J-101	100 1/6W CARBON RES.	
	R513	QRD161J-473	47K 1/6W CARBON RES.	
	R514	QRD161J-103	10K 1/6W CARBON RES.	
	R515	QRD161J-103	10K 1/6W CARBON RES.	
	R516	QRD161J-103	10K 1/6W CARBON RES.	
	R517	QRD161J-103	10K 1/6W CARBON RES.	
	R518	QRD161J-103	10K 1/6W CARBON RES.	
	R519	QRD161J-103	10K 1/6W CARBON RES.	
	R520	QRD161J-331	330 1/6W CARBON RES.	
	R521	QRD161J-331	330 1/6W CARBON RES.	
	R522	QRD161J-331	330 1/6W CARBON RES.	
	R523	QRD161J-103	10K 1/6W CARBON RES.	
	R524	QRD161J-102	1K 1/6W CARBON RES.	
	R525	QRD161J-221	220 1/6W CARBON RES.	
	R527	QRD161J-221	220 1/6W CARBON RES.	
	R562	QRD167J-272	2.7K 1/6W CARBON RES.	
	R621	QRD161J-103	10K 1/6W CARBON RES.	
	R622	QRD161J-103	10K 1/6W CARBON RES.	
	R623	QRD161J-102	1K 1/6W CARBON RES.	
	R624	QRD161J-472	4.7K 1/6W CARBON RES.	
△	R625	PTH61G25AR4R7M	POSITIVE THE	
	R626	QRD167J-332	3.3K 1/6W CARBON RES.	
	R627	QRD167J-223	22K 1/6W CARBON RES.	
	R628	QRD161J-104	100K 1/6W CARBON RES.	
△	R631	QRD14CJ-2R7S	2.7 1/4W UNF. CARBON R	C J
	R631	QRD14CJ-4R7SX	4.7 1/4W UNF. CARBON R	BS EF EN G U UB US UT
△	R632	QRD14CJ-3R3S	3.3 1/4W UNF. CARBON R	
	R633	QRD14CJ-110SX	11 1/4W CARBON RES.	BS EF EN G U UB US UT
△	R633	QRD14CJ-8R2S	8.2 1/4W UNF. CARBON R	C J
△	R634	QRD14CJ-100SX	10 1/4W UNF. CARBON R	
	R637	QRD161J-331	330 1/6W CARBON RES.	
	R651	QRD167J-332	3.3K 1/6W CARBON RES.	
	R652	QRD161J-681	680 1/6W CARBON RES.	
	R653	QRD161J-123	12K 1/6W CARBON RES.	
	R655	QRD161J-512	5.1K 1/6W CARBON RES.	
	R656	QRD161J-122	1.2K 1/6W CARBON RES.	
	R657	QRD161J-202	2K 1/6W CARBON RES.	
	R658	QRD167J-152	1.5K 1/6W CARBON RES.	
	R659	QRD167J-153	15K 1/6W CARBON RES.	
	R660	QRD161J-392	3.9K 1/6W CARBON RES.	
	R661	QRD161J-182	1.8K 1/6W CARBON RES.	
	R662	QRD161J-222	2.2K 1/6W CARBON RES.	
	R663	QRD161J-102	1K 1/6W CARBON RES.	
	R664	QRD161J-182	1.8K 1/6W CARBON RES.	
	R665	QRD167J-153	15K 1/6W CARBON RES.	
	R666	QRD161J-392	3.9K 1/6W CARBON RES.	
	R667	QRD161J-182	1.8K 1/6W CARBON RES.	
	R668	QRD161J-222	2.2K 1/6W CARBON RES.	
	R669	QRD161J-102	1K 1/6W CARBON RES.	
	R670	QRD161J-182	1.8K 1/6W CARBON RES.	
	R681	QRG01DJ-100X	10 1W OXIDE METAL	C J
	R682	QRG01DJ-100X	10 1W OXIDE METAL	C J
	R999	QRD161J-103	10K 1/6W CARBON RES.	
	R1001	QRD14CJ-6R8SX	6.8 1/4W UNF. CARBON R	C J
△	R1002	QRD14CJ-100SX	10 1/4W UNF. CARBON R	C J
	R1515	QRD12CJ-1R0SX	1 1/2W UNF. CARBON R	C J
	VR300	QVDB94B-E15H	100K VARIABLE RE	
	VR321	QVJB81B-E54D	50K VARIABLE RE	
	VR322	QVJB81B-E54D	50K VARIABLE RE	
	VR323	QVJB81M-E54B	50K VARIABLE RE	
	OTHERS			
	ENW10581-102	PRINTED BOARD		
	E309629-001SS	LED HOLDER		
	J703	QMS3L10-0AO MICROPHONE JACK		
	J791	QMS3R80-EEOS HEADPHONE JACK		

△	Item	Parts Number	Description	Area
	L901	EQL4007-6R8T	INDUCTOR	
	L902	EQL4007-R56T	INDUCTOR	
	L903	EQL4007-3R3T	INDUCTOR	
	L904	EQL4007-R56T	INDUCTOR	
	L905	EQL4007-3R3T	INDUCTOR	
	LG001	EMV9519-001	LUG	BS EF EN G
	S501	ESP0001-023M	TACT SWITCH	
	S502	ESP0001-023M	TACT SWITCH	
	S503	ESP0001-023M	TACT SWITCH	
	S507	ESP0001-023M	TACT SWITCH	
	S508	ESP0001-023M	TACT SWITCH	
	S509	ESP0001-023M	TACT SWITCH	
	TW111	QWE350-134K4K	WIRE	BS EF EN G
	X501	ECX0060-000EM	CERAMIC RESONATOR	
	CN213	EWS293-0113	SOCKET WIRE ASSY	
	CN601	EMV7127-015	FEMALE CONNECTOR	
	CN602	EMV7127-013	CONNECT TERMINAL	
	CN603	EMV7127-011	JACK TERMINAL	
	CN604	EMV7163-012	CONNECT TERMINAL	
	CN605	EMV5159-010R	CONNECT TERMINAL	
	CN607	EMV7163-010	CONNECT TERMINAL	
	CN615	EMV7159-010	PIN PLUG	
	CN617	EMV5163-010R	CONNECT TERMINAL	
	CN911	EMV5167-126	CONNECT TERMINAL	
	CN912	EMV5163-010R	CONNECT TERMINAL	
	FW201	EWR35D-16LS	CORD	
	FW606	EWR36D-13LS	CORD	

■ Electrical Parts List (END-104)

△	Item	Parts Number	Description	Area
		CAPACITORS		
	C1011	QFVC1HJ-103ZM	0.01MF 50V METAL.MYLAR	BS EF EN G
	C1012	QFVC1HJ-103ZM	0.01MF 50V METAL.MYLAR	BS EF EN G
	C1015	QCS31HJ-471Z	470PF 50V CER.CAP.	BS EF EN G
	C1016	QCS31HJ-471Z	470PF 50V CER.CAP.	BS EF EN G
	C1017	QCS31HJ-471Z	470PF 50V CER.CAP.	BS EF EN G
		RESISTORS		
	R996	QRD161J-104	100K 1/8W CARBON RES.	U UB US UT
	R997	QRD161J-104	100K 1/8W CARBON RES.	U UB US UT
	R998	QRD161J-104	100K 1/8W CARBON RES.	U UB US UT
	R1011	QRD14CJ-4R7SX	4.7 1/4W UNF.CARBON R	BS EF EN G
	R1012	QRD14CJ-4R7SX	4.7 1/4W UNF.CARBON R	BS EF EN G
△	R1111	QRC128K-275EM	2.7M 1/2W COMPOSITION	C J
		OTHERS		
		ENW10660-002A	PRINTED BOARD	
		E61380-024	FUSE LABEL	C J
		E67132-T2R5	FUSE LABEL	U UB US UT
		QWE882-19RR	VINYL WIRE	
		QWE883-19RR	VINYL WIRE	
		QWE888-19RR	VINYL WIRE	
	J702	ENB00TV-406A	SPEAKER TERMINAL	
	S001	QSR8001-E01U	ROTARY SWITCH	U UB US UT
	CN011	EMV5138-004	PIN CONNECTOR	
	EP001	E70225-003SS	EARTH PLATE	
	EP002	E70225-003SS	EARTH PLATE	
	FS017	E3400-431	FELT SPACER	BS EF EN G
	FT001	EMG7331-003Z	FUSE CLIP	
	FT002	EMG7331-003Z	FUSE CLIP	U UB US UT
	FT011	EMG7331-003Z	FUSE CLIP	
	FT022	EMG7331-003Z	FUSE CLIP	U UB US UT
	TB001	ENZ4001-002Z	TAB	
	TB002	ENZ4001-002Z	TAB	

PARTS LIST

< XL-F3000 >

* All printed circuit boards and its assemblies are not available as service parts.

The Marks for Designated Areas

BS . . . the U.K.	C . . . Canada	EF . . . Continental Europe	EN . . . Scandinavia
G . . . Germany	J . . . the U.S.A.	UB . . . Hong Kong	U . . . Universal Type
US . . . Singapore	UT . . . Taiwan	No marks indicates all areas.	

- Contents -

General Exploded View and Parts List	7-2
Loading Mechanism Ass'y and Parts List	7-4
■ Grease Point	7-4
CD Mechanism Ass'y and Parts List	7-5
■ Grease Point	7-5
Electrical Parts List	7-6
(ENN-483)	7-6

XL-F3000

General Exploded View and Parts List

Block No. **M2MM**

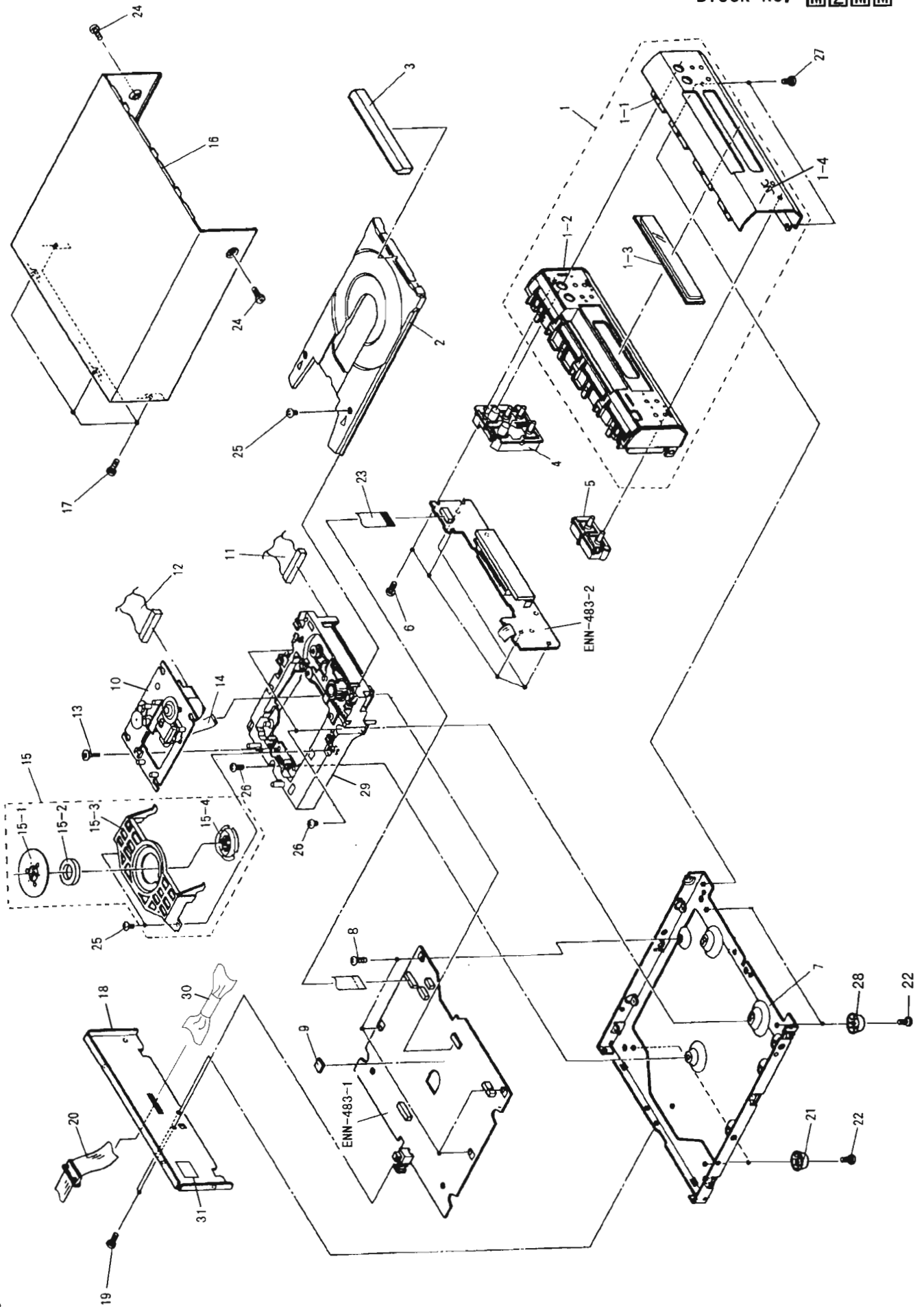

■ Parts List

Block No. **M2M**

△	Item	Parts Number	Parts Name	Q'ty	Description	Area
	1	EFP-XLF3000E(S)	FRONT PANEL ASSY	1		
	1-1	E208737-002	FRONT PANEL	1		
	1-2	E103087-003ST	FRONT BASE	1		
	1-3	E309614-002	WINDOW SCREEN	1		
	1-4	E406971-221	JVC MARK	1		
	2	E102358-332SS	CD TRAY	1		
	3	E309616-004SS	CD FITTING	1		
	4	E208703-003SS	PUSH BUTTON ASSY	1		
	5	E309613-003SS	PUSH BUTTON	1		
	6	SDSF2608Z	SCREW	5		
	7	E103088-001	CHASSIS BASE	1		
	8	SBST3006CC	TAPPING SCREW	4		
	9	E75896-001	SPACER	1		
	10	-----	CD MECHANISM ASSY	1	See Page 7-5	
	11	EWS265-B410	SOCKET WIRE	1		
	12	EWS266-B410	SOCKET WIRE	1		
	13	E406293-001	SPECIAL SCREW	1		
	14	VWF1015-09PPAV	FFC CABLE	1		
	15	E306837-005	CLAMPER ASSY	1		
	15-1	E306836-003	YOKE PLATE	1		
	15-2	E74897-002	MAGNET	1		
	15-3	E26756-002	CLAMPER BASE	1		
	15-4	E306835-001	CD CLAMPER	1		
	16	E208179-013(S)	METAL COVER	1		
	17	GBSG3008CC	TAPPING SCREW	4		
	18	E208705-003	REAR PANEL	1		J
		E208705-004	REAR PANEL	1		C
		E208705-005	REAR PANEL	1		BS EF EN G
		E208705-006	REAR PANEL	1		U UB US UT
	19	E73273-003	SPECIAL SCREW	2		
	20	EWP907-025	FLAT WIRE ASSY	1		
	21	E75281-010	FOOT	2		
	22	SBST3010Z	TAPPING SCREW	4		
	23	VWF1215-16TTB	FLAT WIRE ASSY	1		
	24	SDSG3008N	TAPPING SCREW	2		
	25	SBSF3008Z	TAPPING SCREW	3		
	26	SBST3008Z	TAPPING SCREW	3		
	27	SDSG3008CC	TAPPING SCREW	2		
	28	E75281-009	FOOT	2		
	29	-----	CD LOADING MECHANISM ASSY	1	See Page 7-4	
	30	ENZ8104-005	NOISE FILTER	1		
	31	E406507-001	CAUTION LABEL	1		Except J
	-	E75139-004	NAME LABEL	1		U
		E307570-001	NUMBER LABEL	1		J
		E61029-005	NUMBER LABEL	1		Except J

Loading Mechanism Ass'y and Parts List

Block No. **M3MM**

■ Grease Point

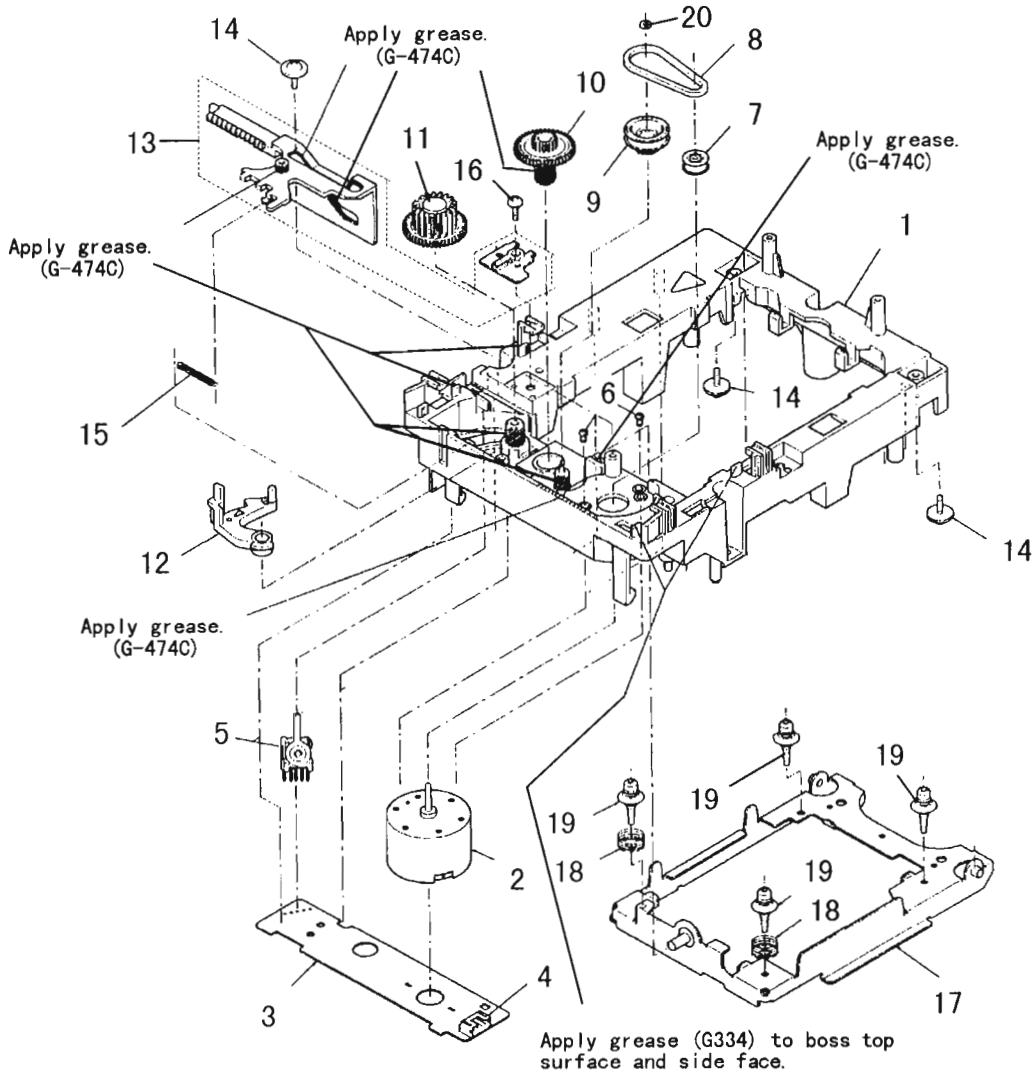

■ Parts List (Loading Mechanism Ass'y)

Block No. **M3MM**

△	Item	Parts Number	Parts Name	Q'ty	Description	Area
	1	E102357-221	LOADING BASE	1		
	2	MMN-6F1LB8K	MOTOR	1		
	3	EMW10264-002	P. C. BOARD	1		
	4	EMV5109-005B	5P PLUG ASSY	1		
	5	ESS1200-002	SWITCH	1		
	6	SPSK2640Z	SCREW	2		
	7	E75984-221	MOTOR PULLEY	1		
	8	E75950-002	BELT	1		
	9	E75985-221SS	GEAR (1)	1		
	10	E75986-221SS	GEAR (2)	1		
	11	E75987-221SS	GEAR (3)	1		
	12	E307162-331	LEVER	1		
	13	E307252-331	CAM PLATE	1		
	14	E65923-003	SCREW	3		
	15	E75989-001	SPRING	1		
	16	SBSF3008Z	SCREW	1		
	17	E307179-332	ELEVATOR BASE ASSY	1		
	18	E406871-001	SPRING	2		
	19	E406294-002	INSULATOR	4		
	20	E60912-005SS	SPEED NUT	1		

CD Mechanism Ass'y and Pars List

■ Grease Point

Block No. **M4M4**

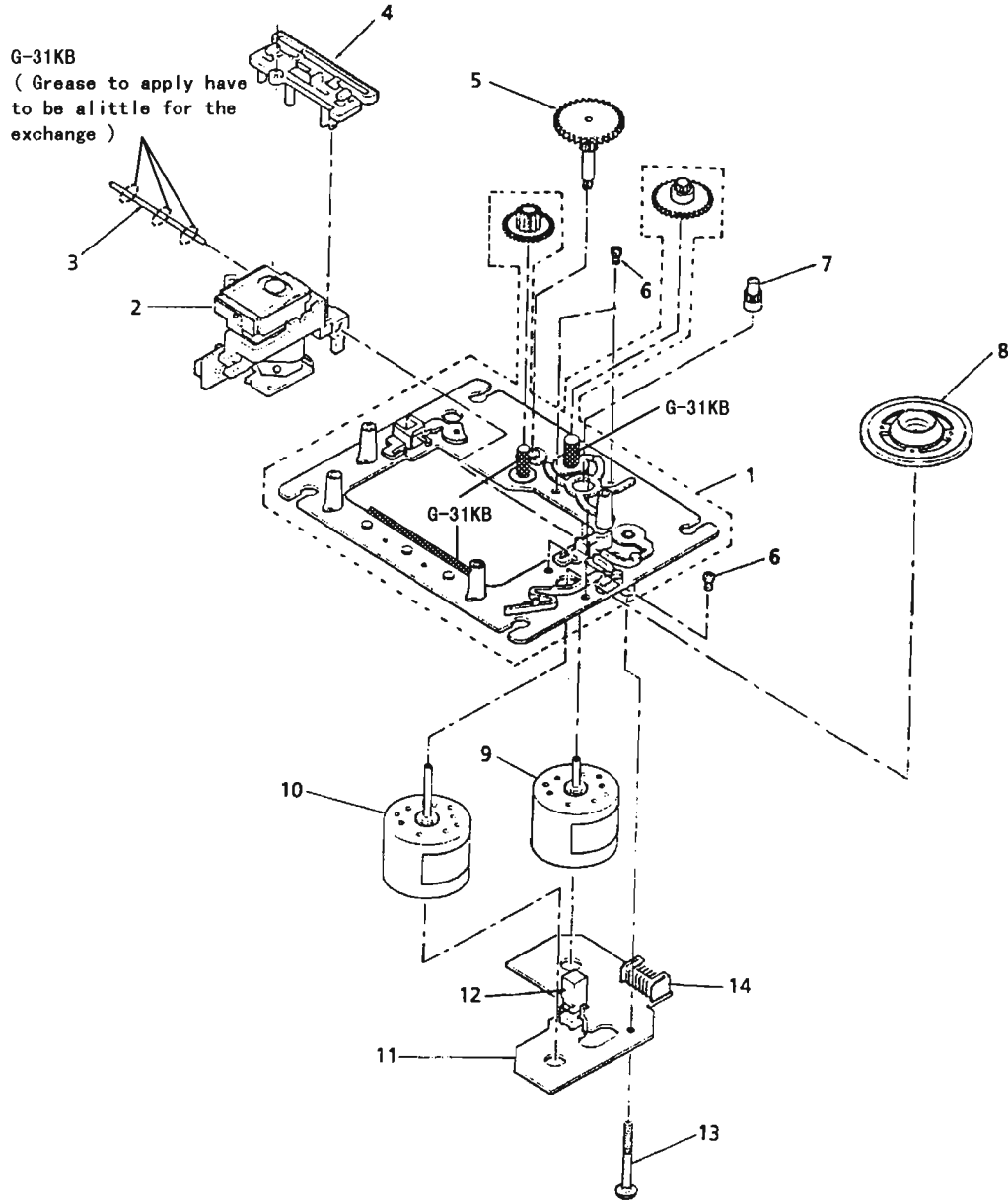

■ Parts List (CD Mechanism Ass'y)

Block No. **M4M4**

△	Item	Parts Number	Parts Name	Q'ty	Description	Area
	1	EPB-002A	MECHA. BASE ASSY	1		
	2	OPTIMA-6S	OPTICAL PICK UP	1		
	3	E407782-001	CD SHAFT	1		
	4	E307746-001	CD RACK	1		
	5	EPB-003A	MECHA GEAR	1		
	6	SDSP2003N	SCREW	3		
	7	E406750-001	PINION GEAR	1		
	8	E75807-302	TURN TABLE	1		
	9	E406784-001	FEED MOTOR	1		
	10	E406783-001	SPINDLE MOTOR	1		
	11	EMW10190-001 (S)	P. C. BOARD	1		
	12	ESB1100-005	LEAF SWITCH	1		
	13	E75832-001	SCREW	1		
	14	EMV5109-006B	CONN. TERMINAL	1	6PIN	

XL-F3000

■ Electrical Parts List (ENN-483)

△	Item	Parts Number	Description	Area
		I. C. S		
	IC401	MN662720RB	I. C (DIGI-MOS)	
	IC501	AN8806SB	I. C (MONO-ANALOG)	
	IC750	MN35503	I. C (DIGI-MOS)	
	IC751	NJM4580DD	I. C (MONO-ANALOG)	
	IC801	BA6398FPX	I. C (MONO-ANALOG)	
	IC851	NJM4558L	I. C (MONO-ANALOG)	
	IC901	MN171602JJX1	I. C (MICRO-COMPUTER)	
	IC902	MN1281 (P, Q)	I. C (DIGI-MOS)	
		DIODES		
	D601	1SR139-200	SI. DIODE	
	D751	1SS119	SI. DIODE	
	D752	1SS119	SI. DIODE	
	D871	1SS119	SI. DIODE	
	D945	1SS119	SI. DIODE	
	D946	1SS119	SI. DIODE	
	D948	1SS119	SI. DIODE	
	D949	1SS119	SI. DIODE	
	D950	1SS119	SI. DIODE	
	D971	SLR-342MCA47	L. E. D.	
		TRANSISTORS		
	Q501	2SA950 (O, Y)	SI. TRANSISTOR	
	Q611	2SA934 (Q, R)	SI. TRANSISTOR	
	Q612	DTA114TS	DIGITAL TRANSISTOR	
	Q851	2SC2060 (Q, R)	SI. TRANSISTOR	
	Q852	2SA934 (Q, R)	SI. TRANSISTOR	
	Q945	DTA114YS	DIGITAL TRANSISTOR	
	Q946	DTC114YS	DIGITAL TRANSISTOR	
	Q971	DTC114YS	DIGITAL TRANSISTOR	
		CAPACITORS		
	C401	QCHB1EZ-223	0.022MF 25V CER. CAP.	
	C402	QCZ0205-155	1.5MF 25V C. CAP.	
	C404	QCHB1EZ-223	0.022MF 25V CER. CAP.	
	C405	QCBB1HK-471Y	470PF 50V CER. CAP.	
	C406	EFH001J-223	METAL. MYLAR	
	C407	QFV81HJ-334	0.33MF 50V TF. CAP.	
	C408	QCZ0205-155	1.5MF 25V C. CAP.	
	C409	QER61AM-107Z	100MF 10V AL E. CAP.	
	C411	QCSB1HK-5R6Y	5.6PF 50V CER. CAP.	
	C416	QCSB1HJ-270Y	27PF 50V CER. CAP.	
	C417	QCSB1HJ-270Y	27PF 50V CER. CAP.	
	C418	QCSB1HJ-270Y	27PF 50V CER. CAP.	
	C421	QCHB1EZ-223	0.022MF 25V CER. CAP.	
	C422	QER51AM-227	220MF 10V AL E. CAP.	
	C423	QCHB1EZ-223	0.022MF 25V CER. CAP.	
	C424	QCHB1EZ-223	0.022MF 25V CER. CAP.	
	C440	QER50JM-107	100MF 6.3V AL E. CAP.	
	C501	QER50JM-107	100MF 6.3V AL E. CAP.	
	C502	QCZ0205-155	1.5MF 25V C. CAP.	
	C504	QER50JM-107	100MF 6.3V AL E. CAP.	
	C505	QCBB1HK-271Y	270PF 50V CER. CAP.	
	C506	QCSB1HJ-470	47PF 50V CER. CAP.	
	C507	QCHB1EZ-223	0.022MF 25V CER. CAP.	
	C509	QCXB1CM-222Y	2200PF 16V CER. CAP.	
	C510	QCHB1EZ-223	0.022MF 25V CER. CAP.	
	C511	QCGB1HK-821	820PF 50V CER. CAP.	
	C514	QCHB1EZ-223	0.022MF 25V CER. CAP.	
	C517	QFLB1HJ-103	0.01MF 50V MYLAR CAP.	
	C518	QEK51HM-105G	1MF 50V AL E. CAP.	
	C519	QFV81HJ-104	0.1MF 50V THIN FILM CA	
	C522	QCHB1EZ-223	0.022MF 25V CER. CAP.	
	C523	QER51VM-106	10MF 35V AL E. CAP.	
	C524	QER50JM-476	47MF 6.3V AL E. CAP.	
	C525	EFH001J-333	METAL. MYLAR	
	C526	QCBB1HK-101Y	100PF 50V CER. CAP.	
	C527	QFV81HJ-273	0.027MF 50V THIN FILM CA	
	C528	QFLB1HJ-472	4700PF 50V MYLAR CAP.	
	C529	QFV81HJ-104	0.1MF 50V THIN FILM CA	
	C530	QCBB1HK-102Y	1000PF 50V CER. CAP.	

△	Item	Parts Number	Description	Area
	C531	QCBB1HK-102Y	1000PF 50V CER. CAP.	
	C541	QCBB1HK-331Y	330PF 50V CER. CAP.	
△	C601	QETB1CM-108	1000MF 16V AL E. CAP.	
	C602	QFLB1HJ-103	0.01MF 50V MYLAR CAP.	
	C603	QCZ0205-155	1.5MF 25V C. CAP.	
	C610	QETB1AM-477	470MF 10V E. CAP.	
	C611	QCF21HP-223A	0.022MF 50V CER. CAP.	
	C612	QETB0JM-338M	3300MF 6.3V AL E. CAP.	
	C621	QCZ0205-155	1.5MF 25V C. CAP.	
	C701	QETB1AM-107	100MF 10V AL E. CAP.	
	C751	QFV81HJ-104	0.1MF 50V THIN FILM CA	
	C752	EETB1AM-107E	100MF 10V E. CAP.	
	C753	EFH001J-104	METAL. MYLAR	
	C754	QCZ0205-155	1.5MF 25V C. CAP.	
	C755	EETB1AM-227E	220MF 10V E. CAP.	
	C756	EFH001J-104	METAL. MYLAR	
	C757	EETB1AM-477E	470MF 10V E. CAP.	
	C758	EETB1AM-477E	470MF 10V E. CAP.	
	C759	QCT30CH-100Y	10PF 50V CER. CAP.	
	C760	QCT30CH-100Y	10PF 50V CER. CAP.	
	C768	QFN31HJ-392Z	3900PF 50V MYLAR CAP.	
	C769	QFN31HJ-392Z	3900PF 50V MYLAR CAP.	
	C770	QCS21HJ-181A	180PF 50V CER. CAP.	
	C771	QCS21HJ-181A	180PF 50V CER. CAP.	
	C772	QFN31HJ-333Z	0.033MF 50V MYLAR CAP.	
	C773	QFN31HJ-333Z	0.033MF 50V MYLAR CAP.	
	C774	EEZ5011-476E	47MF E. CAP.	
	C775	EEZ5011-476E	47MF E. CAP.	
	C778	EETB1HM-475E	4.7MF 50V E. CAP.	
	C779	EETB1HM-475E	4.7MF 50V E. CAP.	
	C780	QCZ0205-155	1.5MF 25V C. CAP.	
	C801	QETB1CM-227	220MF 16V AL E. CAP.	
	C802	QCHB1EZ-223	0.022MF 25V CER. CAP.	
	C803	QFLB1HJ-273	0.027MF 50V MYLAR CAP.	
	C804	QFLB1HJ-183	0.018MF 50V MYLAR CAP.	
	C806	QFV81HJ-273	0.027MF 50V THIN FILM CA	
	C851	QETB1CM-477M	470MF 16V E. CAP.	
	C852	QETB1CM-477M	470MF 16V E. CAP.	
	C854	QCHB1EZ-223	0.022MF 25V CER. CAP.	
	C855	QCHB1EZ-223	0.022MF 25V CER. CAP.	
	C856	QCF21HP-103A	0.01MF 50V CER. CAP.	
	C876	QER51HM-475	4.7MF 50V AL E. CAP.	
	C901	QER51HM-475	4.7MF 50V AL E. CAP.	
	C902	QER51HM-475	4.7MF 50V AL E. CAP.	
	C903	QER50JM-107	100MF 6.3V AL E. CAP.	
	C945	QER61HM-226	22MF 50V AL E. CAP.	
	C946	QER50JM-107	100MF 6.3V AL E. CAP.	
	C947	QCZ0205-155	1.5MF 25V C. CAP.	
	C948	QER50JM-107	100MF 6.3V AL E. CAP.	
	C949	QCHB1EZ-223	0.022MF 25V CER. CAP.	
	C950	QCBB1HK-331Y	330PF 50V CER. CAP.	
		RESISTORS		
	R402	QRD161J-124	120K 1/6W CARBON RES.	
	R403	QRD161J-155	1.5M 1/6W CARBON RES.	
	R404	QRD161J-104	100K 1/6W CARBON RES.	
	R405	QRD161J-104	100K 1/6W CARBON RES.	
	R406	QRD161J-681	680 1/6W CARBON RES.	
	R407	QRD161J-471	470 1/6W CARBON RES.	
	R408	QRD161J-820	82 1/6W CARBON RES.	
	R409	QRD161J-820	82 1/6W CARBON RES.	
	R410	QRD161J-820	82 1/6W CARBON RES.	
	R415	QRD161J-2R2	2.2 1/6W CARBON RES.	
	R416	QRD161J-2R2	2.2 1/6W CARBON RES.	
	R417	QRD161J-102	1K 1/6W CARBON RES.	
	R418	QRD161J-101	100 1/6W CARBON RES.	
	R419	QRD161J-102	1K 1/6W CARBON RES.	
	R420	QRD161J-102	1K 1/6W CARBON RES.	
	R421	QRD161J-102	1K 1/6W CARBON RES.	
	R422	QRD161J-102	1K 1/6W CARBON RES.	

■ Electrical Parts List (ENN-483)

△	Item	Parts Number	Description	Area
	R424	QRD161J-102	1K 1/6W CARBON RES.	
	R425	QRD161J-102	1K 1/6W CARBON RES.	
	R426	QRD161J-102	1K 1/6W CARBON RES.	
	R427	QRD161J-102	1K 1/6W CARBON RES.	
	R428	QRD161J-102	1K 1/6W CARBON RES.	
	R430	QRD167J-152	1.5K 1/6W CARBON RES.	
	R504	QRD161J-114	110K 1/6W CARBON RES.	
	R505	QRD161J-273	27K 1/6W CARBON RES.	
	R507	QRD167J-134	130K 1/6W CARBON RES.	
	R509	QRD161J-103	10K 1/6W CARBON RES.	
	R510	QRD167J-154	150K 1/6W CARBON RES.	
	R511	QRD161J-394	390K 1/6W CARBON RES.	
	R512	QRD161J-913	91K 1/6W CARBON RES.	
	R513	QRD167J-562	5.6K 1/6W CARBON RES.	
	R514	QRD161J-622	6.2K 1/6W CARBON RES.	
	R518	QRD167J-121	120 1/6W CARBON RES.	
	R520	QRD161J-910Y	91 1/6W CARBON RES.	
	R524	QRD161J-470	47 1/6W CARBON RES.	
	R525	QRD161J-470	47 1/6W CARBON RES.	
	R526	QRD161J-470	47 1/6W CARBON RES.	
	R527	QRD161J-2R2	2.2 1/6W CARBON RES.	
	R531	QRD161J-125	1.2M 1/6W CARBON RES.	
△	R601	PTH61G25AR4R7M	POSITIVE THE	Except J
△	R601	QRD12CJ-4R7S	4.7 1/2W UNF. CARBON R	J
	R609	QRD161J-331	330 1/6W CARBON RES.	
	R611	QRD161J-472	4.7K 1/6W CARBON RES.	
	R612	QRD161J-821	820 1/6W CARBON RES.	
	R613	QRD161J-472	4.7K 1/6W CARBON RES.	
	R701	QRD161J-2R2	2.2 1/6W CARBON RES.	
	R750	QRD161J-271	270 1/6W CARBON RES.	
	R751	QRD161J-101	100 1/6W CARBON RES.	
	R752	QRD161J-102	1K 1/6W CARBON RES.	
	R753	QRD167J-560	56 1/6W CARBON RES.	
	R754	QRD167J-560	56 1/6W CARBON RES.	
	R755	QRD161J-271	270 1/6W CARBON RES.	
	R756	QRD161J-101	100 1/6W CARBON RES.	
	R758	QRD161J-101	100 1/6W CARBON RES.	
	R760	ERD004J-163Z	16K CARBON RES.	
	R761	ERD004J-163Z	16K CARBON RES.	
	R762	ERD004J-243Z	24K CARBON RES.	
	R763	ERD004J-243Z	24K CARBON RES.	
	R764	ERD004J-163Z	16K CARBON RES.	
	R765	ERD004J-163Z	16K CARBON RES.	
	R766	ERD004J-243Z	24K CARBON RES.	
	R767	ERD004J-243Z	24K CARBON RES.	
	R768	QRD167J-682	6.8K 1/6W CARBON RES.	
	R769	QRD167J-682	6.8K 1/6W CARBON RES.	
	R772	QRD161J-362	3.6K 1/6W CARBON RES.	
	R773	QRD161J-362	3.6K 1/6W CARBON RES.	
	R774	QRD161J-183	18K 1/6W CARBON RES.	
	R775	QRD161J-183	18K 1/6W CARBON RES.	
	R776	QRD161J-162	1.6K 1/6W CARBON RES.	
	R777	QRD161J-162	1.6K 1/6W CARBON RES.	
	R780	QRD167J-560	56 1/6W CARBON RES.	
	R781	QRD167J-560	56 1/6W CARBON RES.	
	R784	QRD161J-183	18K 1/6W CARBON RES.	
	R785	QRD161J-183	18K 1/6W CARBON RES.	
	R786	QRD161J-271	270 1/6W CARBON RES.	
	R787	QRD161J-271	270 1/6W CARBON RES.	
	R801	QRD161J-821	820 1/6W CARBON RES.	
	R802	QRD167J-562	5.6K 1/6W CARBON RES.	
	R803	QRD161J-112	1.1K 1/6W CARBON RES.	
	R804	QRD167J-113	11K 1/6W CARBON RES.	
	R806	QRD161J-124	120K 1/6W CARBON RES.	
	R807	QRD167J-332	3.3K 1/6W CARBON RES.	
	R808	QRD161J-752	7.5K 1/6W CARBON RES.	
	R809	QRD167J-223	22K 1/6W CARBON RES.	
	R810	QRD161J-392	3.9K 1/6W CARBON RES.	
	R811	QRD167J-153	15K 1/6W CARBON RES.	

△	Item	Parts Number	Description	Area
	R812	QRD161J-752	7.5K 1/6W CARBON RES.	
	R813	QRD167J-751	750 1/6W CARBON RES.	
	R814	QRD161J-363	36K 1/6W CARBON RES.	
△	R851	QRD12CJ-4R7S	4.7 1/2W UNF. CARBON R	
△	R852	QRD12CJ-4R7S	4.7 1/2W UNF. CARBON R	
	R871	QRD161J-513	51K 1/6W CARBON RES.	
	R872	QRD161J-513	51K 1/6W CARBON RES.	
	R873	QRD161J-753	75K 1/6W CARBON RES.	
	R874	QRD161J-623	62K 1/6W CARBON RES.	
	R875	QRD161J-221	220 1/6W CARBON RES.	
	R876	QRD161J-684	680K 1/6W CARBON RES.	
	R877	QRD161J-102	1K 1/6W CARBON RES.	
	R904	QRD161J-472	4.7K 1/6W CARBON RES.	
	R905	QRD161J-472	4.7K 1/6W CARBON RES.	
	R906	QRD161J-472	4.7K 1/6W CARBON RES.	
	R907	QRD161J-472	4.7K 1/6W CARBON RES.	
	R945	QRD161J-473	47K 1/6W CARBON RES.	
	R946	QRD161J-821	820 1/6W CARBON RES.	
	R947	QRD161J-103	10K 1/6W CARBON RES.	
	R965	QRD161J-472	4.7K 1/6W CARBON RES.	
	R966	QRD161J-472	4.7K 1/6W CARBON RES.	
	R967	QRD161J-472	4.7K 1/6W CARBON RES.	
	R971	QRD167J-151	150 1/6W CARBON RES.	
		OTHERS		
		EMW10583-102	PRINTED BOARD	
	J701	GP1F32T	OPTICAL JACK	
	K751	ENZ8101-007	F. BEADS	
	K752	ENZ8101-007	F. BEADS	
	K753	ENZ8101-007	F. BEADS	
	K756	ENZ8101-007	F. BEADS	
	K757	ENZ8101-007	F. BEADS	
	K910	ENZ8101-007	F. BEADS	
	K911	ENZ8101-007	F. BEADS	
	K912	ENZ8101-007	F. BEADS	
	K913	ENZ8101-007	F. BEADS	
	S904	ESPO001-023M	TACT SWITCH	
	S905	ESPO001-023M	TACT SWITCH	
	S906	ESPO001-023M	TACT SWITCH	
	S908	ESPO001-023M	TACT SWITCH	
	S912	ESPO001-023M	TACT SWITCH	
	S913	ESPO001-023M	TACT SWITCH	
	S914	ESPO001-023M	TACT SWITCH	
	X751	ECX0169-344EA	CRYSTAL	
	X901	ECX0060-000EM	CERAMIC RESONATOR	
	CN102	EMV5109-005A	MALE CONNECTOR	
	CN103	EMV5109-006A	CONNECT TERMINAL	
	CN104	EMV7144-015R	CONNECT TERMINAL	
	CN601	EMV7141-013	CONNECT TERMINAL	
	CN701	EMV7123-015	MALE CONNECTOR	
	CN901	EMV7123-015R	MALE CONNECTOR	
	D1901	ELU0001-178	FLUORESCENT DISPLAY TUBE	
	EP601	EMZ4002-002Z	EARTH PLATE	
	EP602	EMZ4002-002Z	EARTH PLATE	
	EP603	EMZ4002-002Z	EARTH PLATE	
	EP604	EMZ4002-002Z	EARTH PLATE	
	FH901	E308892-001ST	FL HOLDER	
	FS901	E306805-075	FELT SPACER	
	FW902	EW37D-16LS	FLAT WIRE ASSY	
	J1701	EMV7145-003Z	SOCKET ASSY	
	J1702	EMV7145-004Z	SOCKET ASSY	
	SP401	VYH7653-002	I. C. SOCKET	
	SP501	VYH7653-008	P. W. BOARD HOLDER	
	SP750	VYH7653-002	I. C. SOCKET	
	SP801	VYH7653-002	I. C. SOCKET	

PARTS LIST

< TD-F3000 >

* All printed circuit boards and its assemblies are not available as service parts.

The Marks for Designated Areas

BS . . . the U.K.	C . . . Canada	EF . . . Continental Europe	EN . . . Scandinavia
G . . . Germany	J . . . the U.S.A.	UB . . . Hong Kong	U . . . Universal Type
US . . . Singapore	UT . . . Taiwan	No marks indicates all areas.	

- Contents -

General Exploded View and Parts List	8-2
Cassette Mechanism Ass'y and Parts List	8-4
■ Grease Point	8-4
Electrical Parts List	8-6
(ENJ-097)	8-6

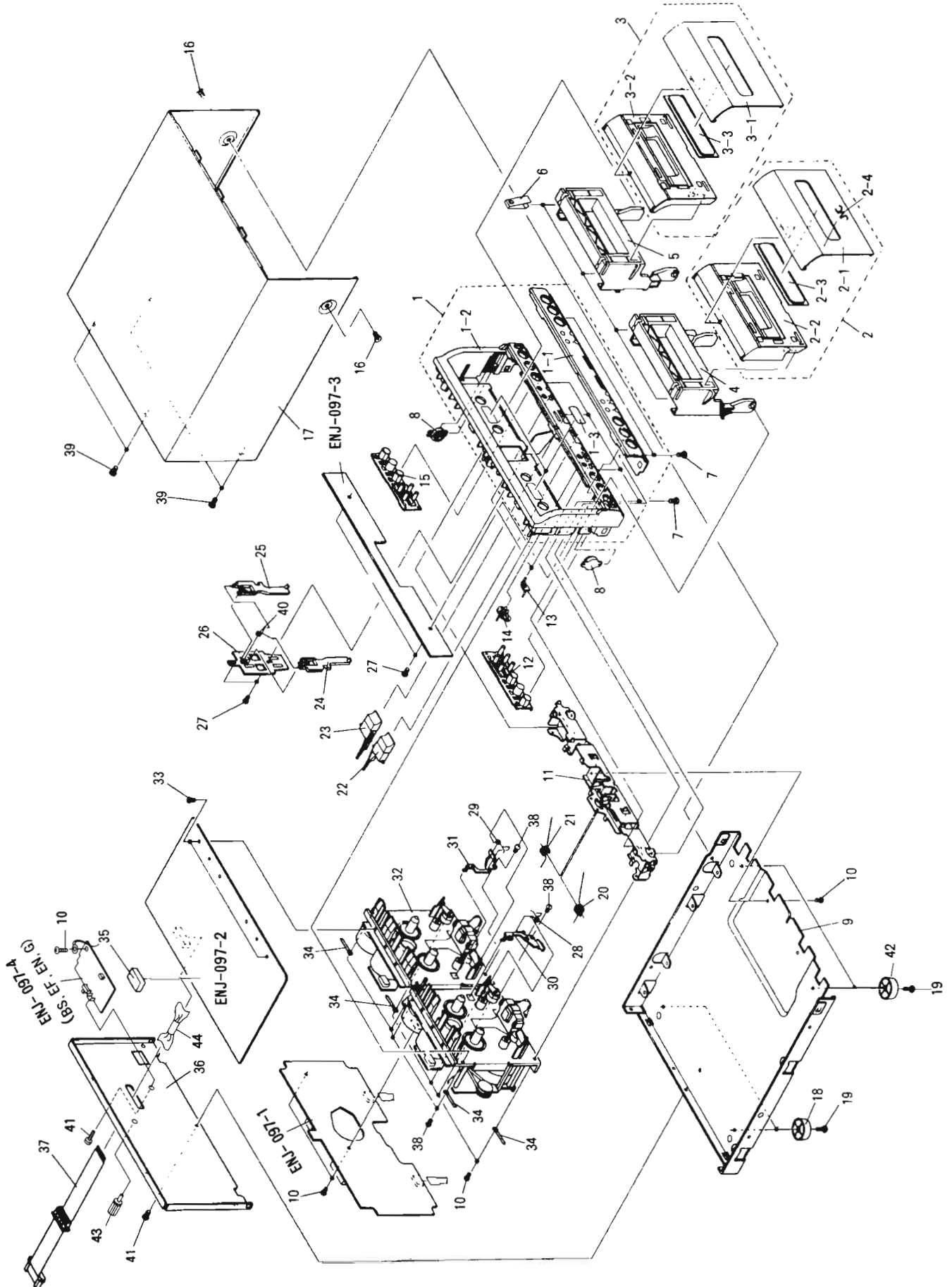

■ Parts List

Block No. **M5MM**

△	Item	Parts Number	Parts Name	Q'ty	Description	Area
	1	EFP-TDF3000E(S)	FRONT PANEL ASSY	1		
	1-1	E208709-003	FRONT PANEL	1		
	1-2	E103091-002ST	FRONT BASE	1		
	1-3	E69777-003	REFLECTION PLATE	2		
	2	E309621-002SA	CASSETTE LID ASSY	1		
	2-1	E309621-002	CASSETTE LID	1		
	2-2	E208720-002ST	LID BASE	1		
	2-3	E309625-001	CASSETTE LENS	1		
	2-4	E406971-221	JVC MARK	1		
	3	E309623-002SA	CASSETTE LID ASSY	1		
	3-1	E309623-002	CASSETTE LID	1		
	3-2	E208721-002ST	LID BASE	1		
	3-3	E309625-001	CASSETTE LENS	1		
	4	E207972-005SS	CASSETTE HOLDER	1		
	5	E207973-005SS	CASSETTE HOLDER	1		
	6	E406713-001	CASSETE SPRING	4		
	7	SDST3008CC	SCREW	6		
	8	E304434-005	DAMPER ASSY	2		
	9	E103092-002	CHASSIS BASE	1		
	10	SBST3006Z	TAPPING SCREW	8		
	11	E208717-001	HOLDER BKT	1		
	12	E208711-003SS	PUSH BUTTON ASSY	1		
	13	E408911-001	INDICATOR	2	REC	
	14	E408910-001	INDICATOR	1	REV.	
	15	E208714-003SS	PUSH BUTTON ASSY	1		
	16	SDSG3008N	TAPPING SCREW	2		
	17	E208174-010(S)	METAL COVER	1		
	18	E75281-010	FOOT	2		
	19	SBST3010Z	TAPPING SCREW	4		
	20	FSKW4002-001	HOLDER SPRING	1		
	21	FSKW4003-001	HOLDER SPRING	1		
	22	E309619-003SS	EJECT BUTTON	1		
	23	E309620-003SS	EJECT BUTTON	1		
	24	E308681-002SS	EJECT LEVER	1		
	25	E308682-002SS	EJECT LEVER	1		
	26	E308683-002	EJECT GUIDE	1		
	27	SDSF2608Z	SCREW	4		
	28	E407801-002	SPRING	1		
	29	E407802-002	SPRING	1		
	30	E407799-001	EJECT BRACKET	1		
	31	E407800-001	EJECT BRACKET	1		
	32	-----	CASSETTE MECHANISM ASSY	1	See page 8-4	
	33	SDST2604Z	SCREW	2		
	34	PU49485-3	CORD CLAMP	4		
	35	E306805-056	SPACER	1		
	36	E208718-002	REAR PANEL	1		J
		E208718-003	REAR PANEL	1		C
		E208718-005	REAR PANEL	1		U UB US UT
		E208718-006	REAR PANEL	1		BS EF EN G
	37	EWP907-020	FLAT WIRE ASSY	1		
	38	SBSF3008Z	TAPPING SCREW	6		
	39	GBSG3008CC	TAPPING SCREW	4		
	40	E407798-002	SPRING	1		
	41	E73273-003	SPECIAL SCREW	1		BS EF EN G
	42	E75281-009	FOOT	2		
	43	E409257-001	EARTH TERMINAL	1		BS EF EN G
	44	ENZ8104-005	NOISE FILTER	1		BS EF EN G
	-	E61029-005	NUMBER LABEL	1		

Cassette Mechanism Ass'y and Parts List

Block No. **M6MM**

■ Grease Point

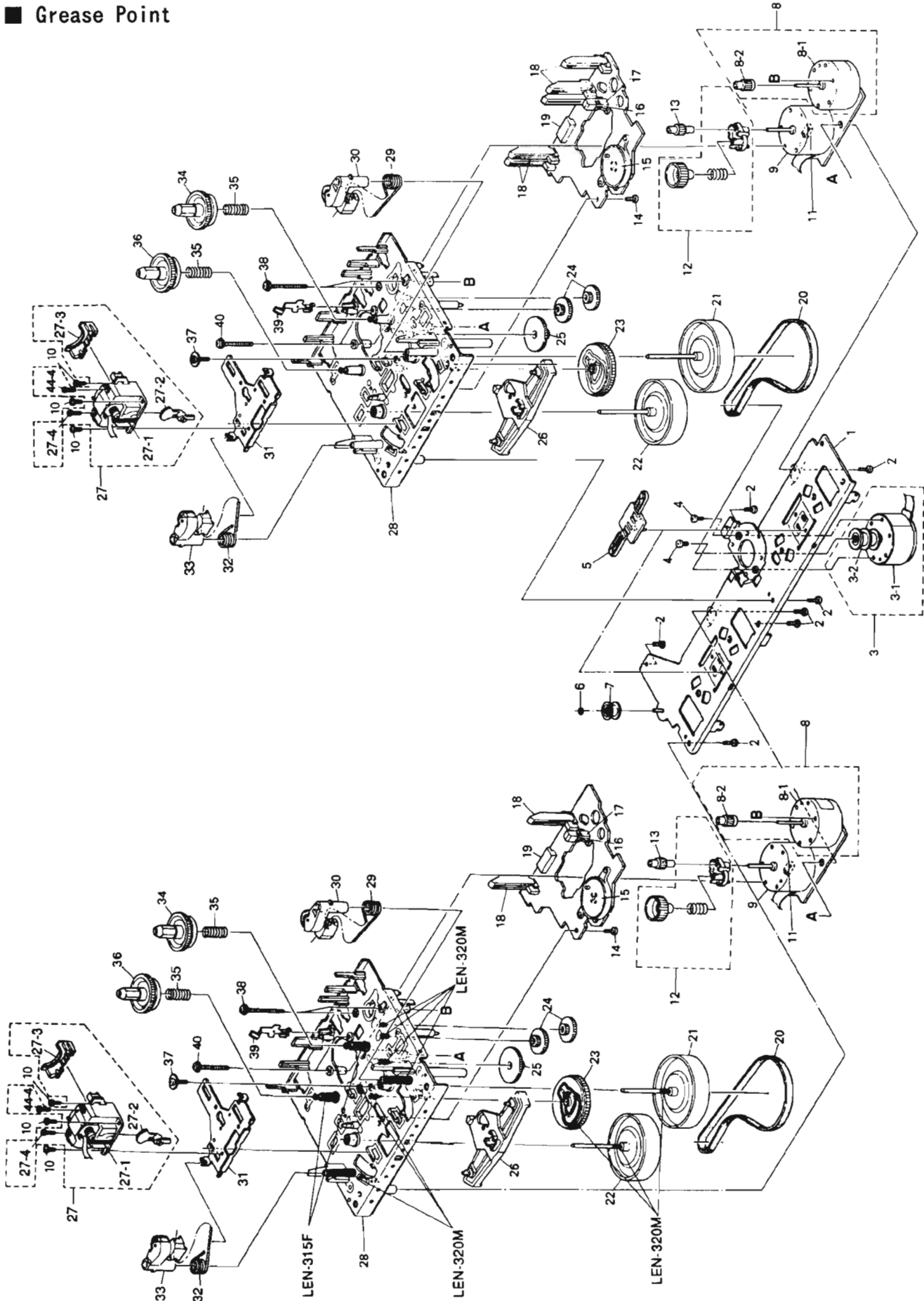

■ Parts List (Cassette Mechanism Ass'y)

Block No. 

△	Item	Parts Number	Parts Name	Q'ty	Description	Area
	1	VKM3775-00A	FM. BKT. ASS'Y	1		
	2	SPSP2603Z	WOOD SCREW	2		
	3	MSI5U2LWA-SA1	DC MOTOR	1	CAPSTAN MOTOR ASSY	
	3-1	MSI-5U2LWA	DC MOTOR	1	CAPSTAN MOTOR	
	3-2	VKR4632-003MM	MOTOR PULLEY	1		
	4	SBSF2608Z	TAPPING SCREW	7		
	5	VKS5327-005MM	LOCK PLATE	2		
	6	WDL163525-4	WASHER	1		
	7	VKR4631-005MM	IDLER PULLEY	1		
	8	MSN5D257A-SA1	DC MOTOR	2	CAM MOTOR ASSY	
	8-1	MSN-5D257A	DC MOTOR	2	CAM MOTOR	
	8-2	VKS5433-001	ACTUATER MOTOR GEAR	2		
	9	MMN-6F4RA38	DC MOTOR	2	REEL MOTOR	
	10	SDSR2004Z	SCREW	6		
	11	VMC0234-R08	CONNECT TERMINAL	2	8PIN	
	12	VKS5430-00CMM	F. F./REW. ARM	2		
	13	VKS5432-001	REEL MOTOR GEAR	2		
	14	SDST2612Z	SCREW	2		
	15	VKS3616-00A	CAM SWITCH	2		
	16	DN6851-HI	I. C (M)	2		
	17	VKS3630-001MM	I. C. PROTECTOR	2		
	18	MXS00220MVLO	CASSETTE SWITCH	7		
	19	VMC0234-R11	CONNECT TERMINAL	1	A MECHA. 11PIN	
		VMC0234-R14	CONNECT TERMINAL	1	B MECHA. 14PIN	
	20	VKB3001-064	DRIVE BELT	1	A MECHA.	
		VKB3001-065	DRIVE BELT	1	B MECHA.	
	21	VKF3184-00H	FLYWHEEL ASS'Y	2	RIGHT	
	22	VKF3186-00H	FLYWHEEL ASS'Y	2	LEFT	
	23	VKS2224-002	CONTROL CAM	2		
	24	VKS5454-001	ACTUATER GEAR	4		
	25	VKS5455-001	ACTUATER GEAR	2		
	26	VKS3627-002	PINCH ROLLER LEVER	2		
	27	VKS3626-00F	H. MOUNT ASS'Y	1	A MECHA.	
		VKS3629-00F	H. MOUNT ASS'Y	1	B MECHA.	
	27-1	VKW5126-001	HEAD SPRING	2		
	27-2	VKS3614-001	TURN OVER GEAR	2		
	27-3	VKS3654-001	HEAD MT. COVER	2		
	27-4	VKZ4629-003	SCREW	4		
	28	VKS1134-00B	CHASSIS BASE	2		
	29	VKW5045-003	PINCH ROLLER SPRING	2	RIGHT	
	30	VKP4227-00B	PINCH ROLLER	2	RIGHT	
	31	VKM3632-001	HEAD BASE	2		
	32	VKW5046-003	PINCH ROLLER SPRING	2	LEFT	
	33	VKP4229-00B	PINCH ROLLER	2	LEFT	
	34	VKS5428-00B	REEL DISK	2		
	35	VKW5043-001	TENSION SPRING	4		
	36	VKS3617-002	REEL DISK	2		
	37	VKZ4708-001	SPECIAL SCREW	2		
	38	VKZ4705-002	SCREW	4		
	39	VKY4670-001	CASSETTE SPRING	2		
	40	VKZ4705-001	SCREW	4		

■ Electrical Parts List (ENJ-097)

△	Item	Parts Number	Description	Area
		I. C. S		
	IC201	AN7374K	I. C (MONO-ANALOG)	
	IC202	BAB221AN	I. C (MONO-ANALOG)	
	IC203	HD6140B1SE39	I. C (MICRO-COMPUTER)	
	IC204	LB1641	I. C (DIGI-OTHER)	
	IC205	LB1641	I. C (DIGI-OTHER)	
	IC206	LB1641	I. C (DIGI-OTHER)	
	IC207	LB1641	I. C (DIGI-OTHER)	
	IC301	BA15218N	I. C (MONO-ANALOG)	
	IC302	UPC1228HA	I. C (MONO-ANALOG)	
	IC303	UPC1228HA	I. C (MONO-ANALOG)	
	IC304	UPC1330HA	I. C (MONO-ANALOG)	
	IC501	UPC1297CA	I. C (MONO-ANALOG)	
		DIODES		
	D201	1SS119	SI. DIODE	
	D202	1SS119	SI. DIODE	
	D203	1SS119	SI. DIODE	
	D204	1SS119	SI. DIODE	
	D205	1SS119	SI. DIODE	
	D206	1SS119	SI. DIODE	
	D207	1SS119	SI. DIODE	
	D208	1SS119	SI. DIODE	
	D209	1SS119	SI. DIODE	
	D210	1SS119	SI. DIODE	
	D211	1SS119	SI. DIODE	
	D213	1SS119	SI. DIODE	
	D214	1SS119	SI. DIODE	
	D215	1SS119	SI. DIODE	
	D216	1SS119	SI. DIODE	
	D217	MTZ3. 9JB	ZENER DIODE	
	D218	1SS119	SI. DIODE	
	D219	1SS119	SI. DIODE	
	D220	1SS119	SI. DIODE	
	D221	1SS119	SI. DIODE	
	D224	1SS119	SI. DIODE	
	D275	1SS119	SI. DIODE	
	D292	1SS119	SI. DIODE	
	D303	1SS119	SI. DIODE	BS EF EN G
	D310	SLR-342MCA47	L. E. D.	
	D311	SLR-342MCA47	L. E. D.	
	D312	SLR-342MCA47	L. E. D.	
	D313	SLR-342MCA47	L. E. D.	
	D314	SLR-342VC3F	L. E. D.	
	D315	SLR-342VC3F	L. E. D.	
	D316	SLR-342VC3F	L. E. D.	
	D317	SLR-342VC3F	L. E. D.	
		TRANSISTORS		
	Q201	DTC144ES	DIGITAL TRANSISTOR	
	Q202	DTC144ES	DIGITAL TRANSISTOR	
	Q203	2SC1740S (R, S)	SI. TRANSISTOR	
	Q204	2SC1740S (R, S)	SI. TRANSISTOR	
	Q205	2SD2144S (VW)	SI. TRANSISTOR	
	Q206	2SD2144S (VW)	SI. TRANSISTOR	
	Q207	DTA144ES	DIGITAL TRANSISTOR	
	Q209	DTC114ES	DIGITAL TRANSISTOR	
	Q210	DTA114YS	DIGITAL TRANSISTOR	
	Q211	2SC1740S (R, S)	SI. TRANSISTOR	
	Q212	2SC1740S (R, S)	SI. TRANSISTOR	
	Q214	DTC144ES	DIGITAL TRANSISTOR	
	Q216	2SA933AS		
	Q217	DTC144ES	DIGITAL TRANSISTOR	
	Q218	DTC144ES	DIGITAL TRANSISTOR	
	Q219	DTA114YS	DIGITAL TRANSISTOR	
	Q220	DTC114YS	DIGITAL TRANSISTOR	
	Q301	2SD2144S (VW)	SI. TRANSISTOR	
	Q302	2SD2144S (VW)	SI. TRANSISTOR	
	Q303	2SC1740S (R, S)	SI. TRANSISTOR	

△	Item	Parts Number	Description	Area
	Q304	2SC1740S (R, S)	SI. TRANSISTOR	
	Q305	2SC1740S (R, S)	SI. TRANSISTOR	
	Q306	2SC1740S (R, S)	SI. TRANSISTOR	
	Q313	DTC144TS	DIGITAL TRANSISTOR	
	Q314	DTC144TS	DIGITAL TRANSISTOR	
	Q315	DTC144TS	DIGITAL TRANSISTOR	
	Q316	DTC144TS	DIGITAL TRANSISTOR	
	Q319	2SA933AS	SI. TRANSISTOR	
	Q320	2SA933AS	SI. TRANSISTOR	
	Q321	2SA933AS	SI. TRANSISTOR	
	Q322	2SA933AS	SI. TRANSISTOR	
	Q327	2SC1740S (R, S)	SI. TRANSISTOR	
	Q328	2SC1740S (R, S)	SI. TRANSISTOR	
	Q329	2SC1740S (R, S)	SI. TRANSISTOR	
	Q330	2SC945A	SI. TRANSISTOR	BS EF EN G
	Q331	DTA144ES	DIGITAL TRANSISTOR	BS EF EN G
	Q501	2SA934 (Q, R)	SI. TRANSISTOR	
	Q502	DTC114YS	DIGITAL TRANSISTOR	
	Q504	DTC114YS	DIGITAL TRANSISTOR	
	Q505	DTC114YS	DIGITAL TRANSISTOR	
	Q506	DTC144ES	DIGITAL TRANSISTOR	
		CAPACITORS		
	C201	QEK51HM-105G	1MF 50V AL E. CAP.	
	C202	QEK51HM-105G	1MF 50V AL E. CAP.	
	C203	QCB1HK-101Y	100PF 50V CER. CAP.	BS EF EN G
	C204	QCB1HK-101Y	100PF 50V CER. CAP.	BS EF EN G
	C205	QEK51HM-105G	1MF 50V AL E. CAP.	
	C206	QEK51HM-105G	1MF 50V AL E. CAP.	
	C207	QETB1HM-106	10MF 50V E. CAP.	
	C208	QETB1HM-106	10MF 50V E. CAP.	
	C209	QFLB1HJ-183	0.018MF 50V MYLAR CAP.	
	C210	QFLB1HJ-183	0.018MF 50V MYLAR CAP.	
	C213	QFLB1HJ-152	1500PF 50V MYLAR CAP.	
	C214	QFLB1HJ-152	1500PF 50V MYLAR CAP.	
	C215	QEK51HM-474G	0.47MF 50V AL E. CAP.	
	C216	QEK51HM-474G	0.47MF 50V AL E. CAP.	
	C217	QFLB1HJ-152	1500PF 50V MYLAR CAP.	
	C218	QFLB1HJ-152	1500PF 50V MYLAR CAP.	
	C219	QEK51HM-474G	0.47MF 50V AL E. CAP.	
	C220	QEK51HM-474G	0.47MF 50V AL E. CAP.	
	C221	QCB1HK-101Y	100PF 50V CER. CAP.	BS EF EN G
	C222	QCB1HK-101Y	100PF 50V CER. CAP.	BS EF EN G
	C223	QFLB1HJ-272	2700PF 50V MYLAR CAP.	
	C224	QFLB1HJ-272	2700PF 50V MYLAR CAP.	
	C225	QETB1EM-106	10MF 25V AL E. CAP.	
	C226	QETB1EM-106	10MF 25V AL E. CAP.	
	C227	QETB1CM-226	22MF 16V E. CAP.	
	C228	QETB1EM-476	47MF 25V AL E. CAP.	
	C229	QETB1CM-226	22MF 16V E. CAP.	
	C231	QETB1CM-476	47MF 16V AL E. CAP.	
	C232	QCZ0205-155	1.5MF 25V C. CAP.	
	C233	QCVB1CM-103Y	0.01MF 16V CER. CAP.	
	C234	QCVB1CM-103Y	0.01MF 16V CER. CAP.	
	C236	QCHB1EZ-223	0.022MF 25V CER. CAP.	
	C237	QCHB1EZ-223	0.022MF 25V CER. CAP.	
	C238	QETB1HM-105	1MF 50V AL E. CAP.	
	C239	QETB1CM-107	100MF 16V AL E. CAP.	
	C240	QCHB1EZ-223	0.022MF 25V CER. CAP.	
	C241	QCHB1EZ-223	0.022MF 25V CER. CAP.	
	C242	QCVB1CM-103Y	0.01MF 16V CER. CAP.	
	C243	QCVB1CM-103Y	0.01MF 16V CER. CAP.	
	C244	QCHB1EZ-223	0.022MF 25V CER. CAP.	
	C245	QCHB1EZ-223	0.022MF 25V CER. CAP.	
	C246	QCVB1CM-103Y	0.01MF 16V CER. CAP.	
	C247	QCVB1CM-103Y	0.01MF 16V CER. CAP.	
	C301	QETB1HM-225	2.2MF 50V AL E. CAP.	
	C302	QETB1HM-225	2.2MF 50V AL E. CAP.	

■ Electrical Parts List (ENJ-097)

△	Item	Parts Number	Description	Area
	C303	QEK51HM-225G	2.2MF 50V AL E. CAP.	
	C304	QEK51HM-225G	2.2MF 50V AL E. CAP.	
	C305	QCB1HK-101Y	100PF 50V CER. CAP.	
	C306	QCB1HK-101Y	100PF 50V CER. CAP.	
	C307	QCB1HK-181Y	180PF 50V CER. CAP.	
	C308	QCB1HK-181Y	180PF 50V CER. CAP.	
	C309	QETB1EM-106	10MF 25V AL E. CAP.	
	C310	QETB1EM-106	10MF 25V AL E. CAP.	
	C311	QCSB1HJ-470	47PF 50V CER. CAP.	
	C312	QCSB1HJ-470	47PF 50V CER. CAP.	
	C313	QETB1CM-107	100MF 18V AL E. CAP.	
	C314	QETB1CM-107	100MF 18V AL E. CAP.	
	C315	QEK51HM-105G	1MF 50V AL E. CAP.	
	C316	QEK51HM-105G	1MF 50V AL E. CAP.	
	C317	QEK51EM-106	10MF 25V AL E. CAP.	
	C318	QETB1CM-107	100MF 18V AL E. CAP.	
	C319	QCF21HP-223A	0.022MF 50V CER. CAP.	BS EF EN G
	C320	QFLB1HJ-682	6800PF 50V MYLAR CAP.	
	C321	QFLB1HJ-332	3300PF 50V MYLAR CAP.	
	C322	QFLB1HJ-332	3300PF 50V MYLAR CAP.	
	C323	QFLB1HJ-183	0.018MF 50V MYLAR CAP.	
	C324	QFP31HG-472	4700PF 50V POLYPROPY. F.I	
	C327	QCB1HK-471Y	470PF 50V CER. CAP.	BS EF EN G
	C328	QCHB1EZ-223	0.022MF 25V CER. CAP.	BS EF EN G
	C341	QFLB1HJ-223	0.022MF 50V MYLAR CAP.	
	C342	QFLB1HJ-223	0.022MF 50V MYLAR CAP.	
	C345	QFLB1HJ-123	0.012MF 50V MYLAR CAP.	
	C346	QFLB1HJ-123	0.012MF 50V MYLAR CAP.	
	C347	QFLB1HJ-103	0.01MF 50V MYLAR CAP.	
	C348	QFLB1HJ-103	0.01MF 50V MYLAR CAP.	
	C360	QETB1CM-226	22MF 16V E. CAP.	
	C361	QCF21HP-473A	0.047MF 50V CER. CAP.	
	C362	QCF21HP-473A	0.047MF 50V CER. CAP.	
	C364	QETB1CM-107	100MF 18V AL E. CAP.	
	C365	QETB1HM-225	2.2MF 50V AL E. CAP.	
	C366	QETB1HM-225	2.2MF 50V AL E. CAP.	
	C367	QFLB1HJ-822	8200PF 50V MYLAR CAP.	
	C368	QFLB1HJ-822	8200PF 50V MYLAR CAP.	
	C369	QETB1AM-107	100MF 10V AL E. CAP.	
	C370	QETB1AM-107	100MF 10V AL E. CAP.	
	C371	QEK51HM-225G	2.2MF 50V AL E. CAP.	
	C372	QEK51HM-225G	2.2MF 50V AL E. CAP.	
	C373	QETB1EM-106	10MF 25V AL E. CAP.	
	C374	QETB1CM-107	100MF 18V AL E. CAP.	
	C375	QCB1HK-101Y	100PF 50V CER. CAP.	C J U UB US UT
		QCB1HK-471Y	470PF 50V CER. CAP.	BS EF EN G
	C376	QCB1HK-101Y	100PF 50V CER. CAP.	C J U UB US UT
		QCB1HK-471Y	470PF 50V CER. CAP.	BS EF EN G
	C377	QCY31HK-182Z	1800PF 50V CER. CAP.	
	C378	QCY31HK-182Z	1800PF 50V CER. CAP.	
	C379	QCB1HK-331Y	330PF 50V CER. CAP.	
	C380	QCB1HK-331Y	330PF 50V CER. CAP.	
	C381	QETB1CM-107	100MF 18V AL E. CAP.	
	C383	QETB1HM-225	2.2MF 50V AL E. CAP.	
	C384	QETB1HM-225	2.2MF 50V AL E. CAP.	
	C385	QFLB1HJ-822	8200PF 50V MYLAR CAP.	
	C386	QFLB1HJ-822	8200PF 50V MYLAR CAP.	
	C387	QETB1AM-107	100MF 10V AL E. CAP.	
	C388	QETB1AM-107	100MF 10V AL E. CAP.	
	C389	QETB1HM-225	2.2MF 50V AL E. CAP.	
	C390	QETB1HM-225	2.2MF 50V AL E. CAP.	
	C391	QETB1EM-106	10MF 25V AL E. CAP.	
	C392	QETB1CM-107	100MF 18V AL E. CAP.	
	C393	QCB1HK-101Y	100PF 50V CER. CAP.	C J U UB US UT
		QCB1HK-471Y	470PF 50V CER. CAP.	BS EF EN G
	C394	QCB1HK-101Y	100PF 50V CER. CAP.	C J U UB US UT
		QCB1HK-471Y	470PF 50V CER. CAP.	BS EF EN G

△	Item	Parts Number	Description	Area
	C395	QCXB1CM-182Y	1800PF 16V CER. CAP.	
	C396	QCXB1CM-182Y	1800PF 16V CER. CAP.	
	C397	QCB1HK-331Y	330PF 50V CER. CAP.	
	C398	QCB1HK-331Y	330PF 50V CER. CAP.	
	C501	QETB1EM-106	10MF 25V AL E. CAP.	
	C502	QETB1EM-106	10MF 25V AL E. CAP.	
	C503	QFP81HG-821	820PF 50V POLYPROPY. F.I	
	C504	QFP81HG-821	820PF 50V POLYPROPY. F.I	
	C506	QETB1EM-106	10MF 25V AL E. CAP.	
	C507	QFLB1HJ-103	0.01MF 50V MYLAR CAP.	
	C508	QFLB1HJ-103	0.01MF 50V MYLAR CAP.	
	C509	QCF31HP-102Z	1000PF 50V CER. CAP.	
	C510	QCF31HP-102Z	1000PF 50V CER. CAP.	
	C511	QFLB1HJ-223	0.022MF 50V MYLAR CAP.	
	C512	QFLB1HJ-223	0.022MF 50V MYLAR CAP.	
	C513	QFLB1HJ-333	0.033MF 50V MYLAR CAP.	
	C514	QFLB1HJ-333	0.033MF 50V MYLAR CAP.	
	C515	QETB1CM-107	100MF 18V AL E. CAP.	
	C516	QCS21HJ-100	10PF 50V CER. CAP.	
	C525	QCB1HK-101Y	100PF 50V CER. CAP.	
	C526	QCB1HK-101Y	100PF 50V CER. CAP.	
	C541	QETB1EM-106	10MF 25V AL E. CAP.	
	C991	QCVB1CM-103Y	0.01MF 18V CER. CAP.	
	C992	QCVB1CM-103Y	0.01MF 16V CER. CAP.	
		RESISTORS		
	R201	QRD161J-221	220 1/6W CARBON RES.	
	R202	QRD161J-221	220 1/6W CARBON RES.	
	R203	QRD161J-393	39K 1/6W CARBON RES.	
	R204	QRD161J-393	39K 1/6W CARBON RES.	
	R205	QRD161J-754	750K 1/6W CARBON RES.	
	R206	QRD161J-754	750K 1/6W CARBON RES.	
	R207	QRD161J-103	10K 1/6W CARBON RES.	
	R208	QRD161J-103	10K 1/6W CARBON RES.	
	R209	QRD167J-223	22K 1/6W CARBON RES.	
	R210	QRD167J-223	22K 1/6W CARBON RES.	
	R211	QRD161J-122	1.2K 1/6W CARBON RES.	
	R212	QRD161J-122	1.2K 1/6W CARBON RES.	
	R213	QRD161J-103	10K 1/6W CARBON RES.	
	R214	QRD161J-103	10K 1/6W CARBON RES.	
	R215	QRD161J-105	1M 1/6W CARBON RES.	
	R216	QRD161J-274	270K 1/6W CARBON RES.	
	R217	QRD161J-104	100K 1/6W CARBON RES.	
	R218	QRD161J-102	1K 1/6W CARBON RES.	
	R219	QRD161J-103	10K 1/6W CARBON RES.	
	R220	QRD167J-223	22K 1/6W CARBON RES.	
	R221	QRD161J-103	10K 1/6W CARBON RES.	
	R222	QRD161J-103	10K 1/6W CARBON RES.	
	R223	QRD161J-103	10K 1/6W CARBON RES.	
△	R224	QRD14CJ-100SX	10 1/4W UNF. CARBON R	
	R225	QRD167J-562	5.6K 1/6W CARBON RES.	
	R226	QRD167J-562	5.6K 1/6W CARBON RES.	
	R227	QRD161J-102	1K 1/6W CARBON RES.	
	R228	QRD161J-102	1K 1/6W CARBON RES.	
	R229	QRD167J-223	22K 1/6W CARBON RES.	
	R232	QRD161J-221	220 1/6W CARBON RES.	
	R233	QRD161J-105	1M 1/6W CARBON RES.	
	R234	QRD161J-221	220 1/6W CARBON RES.	
	R235	QRD161J-472	4.7K 1/6W CARBON RES.	
	R236	QRD161J-301	300 1/6W CARBON RES.	
	R237	QRD161J-301	300 1/6W CARBON RES.	
	R238	QRD161J-301	300 1/6W CARBON RES.	
	R239	QRD161J-301	300 1/6W CARBON RES.	
	R240	QRD161J-301	300 1/6W CARBON RES.	
	R241	QRD161J-301	300 1/6W CARBON RES.	
	R242	QRD161J-301	300 1/6W CARBON RES.	
	R243	QRD161J-301	300 1/6W CARBON RES.	
	R244	QRD161J-105	1M 1/6W CARBON RES.	

■ Electrical Parts List (ENJ-097)

△	Item	Parts Number	Description	Area
	R245	QRD161J-103	10K 1/6W CARBON RES.	
	R246	QRD161J-105	1M 1/6W CARBON RES.	
	R247	QRD161J-913	91K 1/6W CARBON RES.	
	R248	QRD161J-104	100K 1/6W CARBON RES.	
	R251	QRD161J-224	220K 1/6W CARBON RES.	
	R253	QRD161J-103	10K 1/6W CARBON RES.	
	R257	QRD161J-683	68K 1/6W CARBON RES.	
	R258	QRD167J-113	11K 1/6W CARBON RES.	
	R259	QRD167J-822	8.2K 1/6W CARBON RES.	
	R260	QRD167J-822	8.2K 1/6W CARBON RES.	
	R261	QRD161J-913	91K 1/6W CARBON RES.	
	R262	QRD161J-913	91K 1/6W CARBON RES.	
	R263	QRD161J-163	16K 1/6W CARBON RES.	
	R264	QRD161J-163	16K 1/6W CARBON RES.	
	R265	QRD161J-432	4.3K 1/6W CARBON RES.	
	R266	QRD161J-432	4.3K 1/6W CARBON RES.	
	R267	QRD161J-103	10K 1/6W CARBON RES.	
	R268	QRD161J-103	10K 1/6W CARBON RES.	
	R269	QRD161J-222	2.2K 1/6W CARBON RES.	
	R270	QRD161J-222	2.2K 1/6W CARBON RES.	
	R271	QRD161J-103	10K 1/6W CARBON RES.	
	R279	QRD167J-153	15K 1/6W CARBON RES.	
	R280	QRD161J-221	220 1/6W CARBON RES.	
	R283	QRD161J-100	10 1/6W CARBON RES.	
	R284	QRD161J-100	10 1/6W CARBON RES.	
	R285	QRD161J-393	39K 1/6W CARBON RES.	
	R286	QRD161J-393	39K 1/6W CARBON RES.	
	R287	QRD14CJ-6R8SX	6.8 1/4W UNF. CARBON R	
△	R288	QRD14CJ-100SX	10 1/4W UNF. CARBON R	
	R293	QRD161J-331	330 1/6W CARBON RES.	
	R294	QRD161J-271	270 1/6W CARBON RES.	
	R296	QRD161J-104	100K 1/6W CARBON RES.	
	R297	QRD167J-332	3.3K 1/6W CARBON RES.	
	R298	QRD161J-561	560 1/6W CARBON RES.	BS EF EN G
	R301	QRD161J-103	10K 1/6W CARBON RES.	
	R302	QRD161J-103	10K 1/6W CARBON RES.	
	R303	QRD167J-562	5.6K 1/6W CARBON RES.	
	R304	QRD167J-562	5.6K 1/6W CARBON RES.	
	R315	QRD161J-103	10K 1/6W CARBON RES.	
	R316	QRD161J-103	10K 1/6W CARBON RES.	
	R317	QRD161J-103	10K 1/6W CARBON RES.	
	R318	QRD161J-103	10K 1/6W CARBON RES.	
	R319	QRD161J-103	10K 1/6W CARBON RES.	
	R320	QRD161J-103	10K 1/6W CARBON RES.	
	R321	QRD161J-103	10K 1/6W CARBON RES.	
	R322	QRD161J-103	10K 1/6W CARBON RES.	
	R323	QRD167J-562	5.6K 1/6W CARBON RES.	
	R324	QRD167J-562	5.6K 1/6W CARBON RES.	
	R325	QRD167J-562	5.6K 1/6W CARBON RES.	
	R326	QRD167J-562	5.6K 1/6W CARBON RES.	
	R339	QRD167J-272	2.7K 1/6W CARBON RES.	
	R340	QRD167J-272	2.7K 1/6W CARBON RES.	
	R341	QRD161J-512	5.1K 1/6W CARBON RES.	
	R342	QRD161J-512	5.1K 1/6W CARBON RES.	
	R343	QRD161J-432	4.3K 1/6W CARBON RES.	
	R344	QRD161J-432	4.3K 1/6W CARBON RES.	
	R345	QRD161J-512	5.1K 1/6W CARBON RES.	
	R346	QRD161J-512	5.1K 1/6W CARBON RES.	
	R347	QRD161J-820	82 1/6W CARBON RES.	
	R348	QRD161J-820	82 1/6W CARBON RES.	
	R351	QRD161J-242	2.4K 1/6W CARBON RES.	
	R352	QRD161J-242	2.4K 1/6W CARBON RES.	
	R355	QRD161J-243	24K 1/6W CARBON RES.	
	R356	QRD161J-243	24K 1/6W CARBON RES.	
	R357	QRD161J-683	68K 1/6W CARBON RES.	
	R358	QRD161J-683	68K 1/6W CARBON RES.	
	R359	QRD167J-223	22K 1/6W CARBON RES.	

△	Item	Parts Number	Description	Area
	R360	QRD167J-223	22K 1/6W CARBON RES.	
	R361	QRD161J-393	39K 1/6W CARBON RES.	
	R362	QRD161J-393	39K 1/6W CARBON RES.	
	R363	QRD161J-221	220 1/6W CARBON RES.	
	R364	QRD161J-221	220 1/6W CARBON RES.	
	R365	QRD161J-470	47 1/6W CARBON RES.	BS EF EN G
	R366	QRD161J-470	47 1/6W CARBON RES.	BS EF EN G
	R367	QRD167J-334	330K 1/6W CARBON RES.	
	R368	QRD167J-334	330K 1/6W CARBON RES.	
	R369	QRD161J-470	47 1/6W CARBON RES.	
	R370	QRD161J-470	47 1/6W CARBON RES.	
	R371	QRD167J-682	6.8K 1/6W CARBON RES.	
	R372	QRD167J-682	6.8K 1/6W CARBON RES.	
	R375	QRD161J-752	7.5K 1/6W CARBON RES.	
	R376	QRD161J-752	7.5K 1/6W CARBON RES.	
	R377	QRD161J-224	220K 1/6W CARBON RES.	
	R378	QRD161J-224	220K 1/6W CARBON RES.	
	R379	QRD161J-102	1K 1/6W CARBON RES.	
	R380	QRD161J-473	47K 1/6W CARBON RES.	
	R381	QRD161J-471	470 1/6W CARBON RES.	
	R382	QRD161J-471	470 1/6W CARBON RES.	
	R383	QRD161J-470	47 1/6W CARBON RES.	BS EF EN G
	R384	QRD161J-470	47 1/6W CARBON RES.	BS EF EN G
	R385	QRD167J-334	330K 1/6W CARBON RES.	
	R386	QRD167J-334	330K 1/6W CARBON RES.	
	R387	QRD161J-470	47 1/6W CARBON RES.	
	R388	QRD161J-470	47 1/6W CARBON RES.	
	R389	QRD167J-682	6.8K 1/6W CARBON RES.	
	R390	QRD167J-682	6.8K 1/6W CARBON RES.	
	R393	QRD161J-752	7.5K 1/6W CARBON RES.	
	R394	QRD161J-752	7.5K 1/6W CARBON RES.	
	R395	QRD161J-224	220K 1/6W CARBON RES.	
	R396	QRD161J-224	220K 1/6W CARBON RES.	
	R397	QRD161J-102	1K 1/6W CARBON RES.	
	R398	QRD161J-102	1K 1/6W CARBON RES.	
	R492	QRD161J-103	10K 1/6W CARBON RES.	
	R501	QRD161J-103	10K 1/6W CARBON RES.	
	R502	QRD161J-222	2.2K 1/6W CARBON RES.	
△	R503	QRD14CJ-100SX	10 1/4W UNF. CARBON R	
△	R504	QRD14CJ-100SX	10 1/4W UNF. CARBON R	
△	R506	QRD14CJ-100SX	10 1/4W UNF. CARBON R	
	R507	QRD161J-183	18K 1/6W CARBON RES.	
	R508	QRD161J-183	18K 1/6W CARBON RES.	
	R509	QRD167J-154	150K 1/6W CARBON RES.	
	R510	QRD167J-154	150K 1/6W CARBON RES.	
	R511	QRD161J-392	3.9K 1/6W CARBON RES.	
	R515	QRD167J-682	6.8K 1/6W CARBON RES.	
	R520	QRD161J-362	3.6K 1/6W CARBON RES.	
	R523	QRD167J-272	2.7K 1/6W CARBON RES.	
	R541	QRD167J-332	3.3K 1/6W CARBON RES.	
	R600	QRD161J-221	220 1/6W CARBON RES.	BS EF EN G
	R991	QRD161J-103	10K 1/6W CARBON RES.	
	R992	QRD161J-103	10K 1/6W CARBON RES.	
	RA201	ORB049J-103	10K 1/10WRES.	
	RA202	ORB089J-103	10K 1/10WNETWORK RES.	
	VR201	QVPA603-103A	10K TRIMMER RES.	
	VR301	QVPA603-201AZ	200 VARIABLE RE	
	VR302	QVPA603-201AZ	200 VARIABLE RE	
	VR303	QVPA603-201AZ	200 VARIABLE RE	
	VR304	QVPA603-201AZ	200 VARIABLE RE	
	VR305	QVPA603-104A	100K TRIMMER RES.	
	VR306	QVPA603-104A	100K TRIMMER RES.	
	VR307	QVPA603-104A	100K TRIMMER RES.	
	VR308	QVPA603-104A	100K TRIMMER RES.	
	VR311	QVPA603-503A	50K VARIABLE RE	
	VR312	QVPA603-503A	50K VARIABLE RE	
	VR513	QVPA603-203M	20K TRIMMER RES.	

■ Electrical Parts List (ENJ-097)

△	Item	Parts Number	Description	Area
	VR514	QVPA603-203M	20K TRIMMER RES.	
		OTHERS		
		EMW10584-102	PRINTED BOARD	
	J303	VMC0314-S08	CONNECT TERMINAL	
	J304	VMC0314-S12	CONNECT TERMINAL	
	K303	ENZ8101-007	INDUCTOR	BS EF EN G
	L301	ENZ6002-012	OSCILLATOR COIL	
	L303	EQL2106-562	INDUCTOR	
	L304	EQL2106-562	INDUCTOR	
	L305	EQL2106-223	INDUCTOR	
	L306	EQL2106-223	INDUCTOR	
	L501	ENZ2500-001	OSCILLATOR COIL	
	L502	ENZ2500-001	OSCILLATOR COIL	
	P201	VMC0234-P11	CONNECT TERMINAL	
	P202	VMC0234-P14	CONNECT TERMINAL	
	P203	VMC0234-P08	CONNECT TERMINAL	
	P204	VMC0234-P08	CONNECT TERMINAL	
	P292	EMV5142-909	CONNECT TERMINAL	
	P293	EMV5142-908	CONNECT TERMINAL	
	P303	EMV5132-008R	CONNECT TERMINAL	
	P304	EMV5132-012R	CONNECT TERMINAL	
	P331	EMV7155-106R	CONNECT TERMINAL	
	P333	EMV7155-106R	CONNECT TERMINAL	
	P702	EMV7145-003Z	SOCKET ASSY	BS EF EN G
	S300	ESP0001-023M	TACT SWITCH	
	S301	ESP0001-023M	TACT SWITCH	
	S302	ESP0001-023M	TACT SWITCH	
	S303	ESP0001-023M	TACT SWITCH	
	S310	ESP0001-023M	TACT SWITCH	
	S311	ESP0001-023M	TACT SWITCH	
	S312	ESP0001-023M	TACT SWITCH	
	S313	ESP0001-023M	TACT SWITCH	
	S320	ESP0001-023M	TACT SWITCH	
	S321	ESP0001-023M	TACT SWITCH	
	S322	ESP0001-023M	TACT SWITCH	
	S330	ESP0001-023M	TACT SWITCH	
	S331	ESP0001-023M	TACT SWITCH	
	S332	ESP0001-023M	TACT SWITCH	
	S333	ESP0001-023M	TACT SWITCH	
	S941	QSS7A12-E01	SLIDE SWITCH	BS EF EN G
	BC292	EWS329-A920	SOCKET WIRE ASSY	
	BC293	EWS328-A920	SOCKET WIRE ASSY	
	CN221	EMV7141-015	PIN CONNECTOR	
	CN701	EMV7145-004Z	SOCKET ASSY	
	EP302	E70225-003SS	EARTH PLATE	BS EF EN G
	FW701	EWR34D-08LS	FLAT WIRE ASSY	
	FW702	EWR33D-20LS	FLAT WIRE ASSY	BS EF EN G
	TW010	EWT015-002	TERMINAL WIRE	
	XT201	ECX0004-194KM	CERAMIC RESONATOR	

PARTS LIST

< FX-F3000 >

* All printed circuit boards and its assemblies are not available as service parts.

The Marks for Designated Areas

BS . . . the U.K.	C . . . Canada	EF . . . Continental Europe	EN . . . Scandinavia
G . . . Germany	J . . . the U.S.A.	UB . . . Hong Kong	U . . . Universal Type
US . . . Singapore	UT . . . Taiwan	No marks indicates all areas.	

- Contents -

General Exploded View and Parts List	9-2
Electrical Parts List	9-4
(ENA-177)	9-4

General Exploded View and Parts List

Block No. **M7MM**

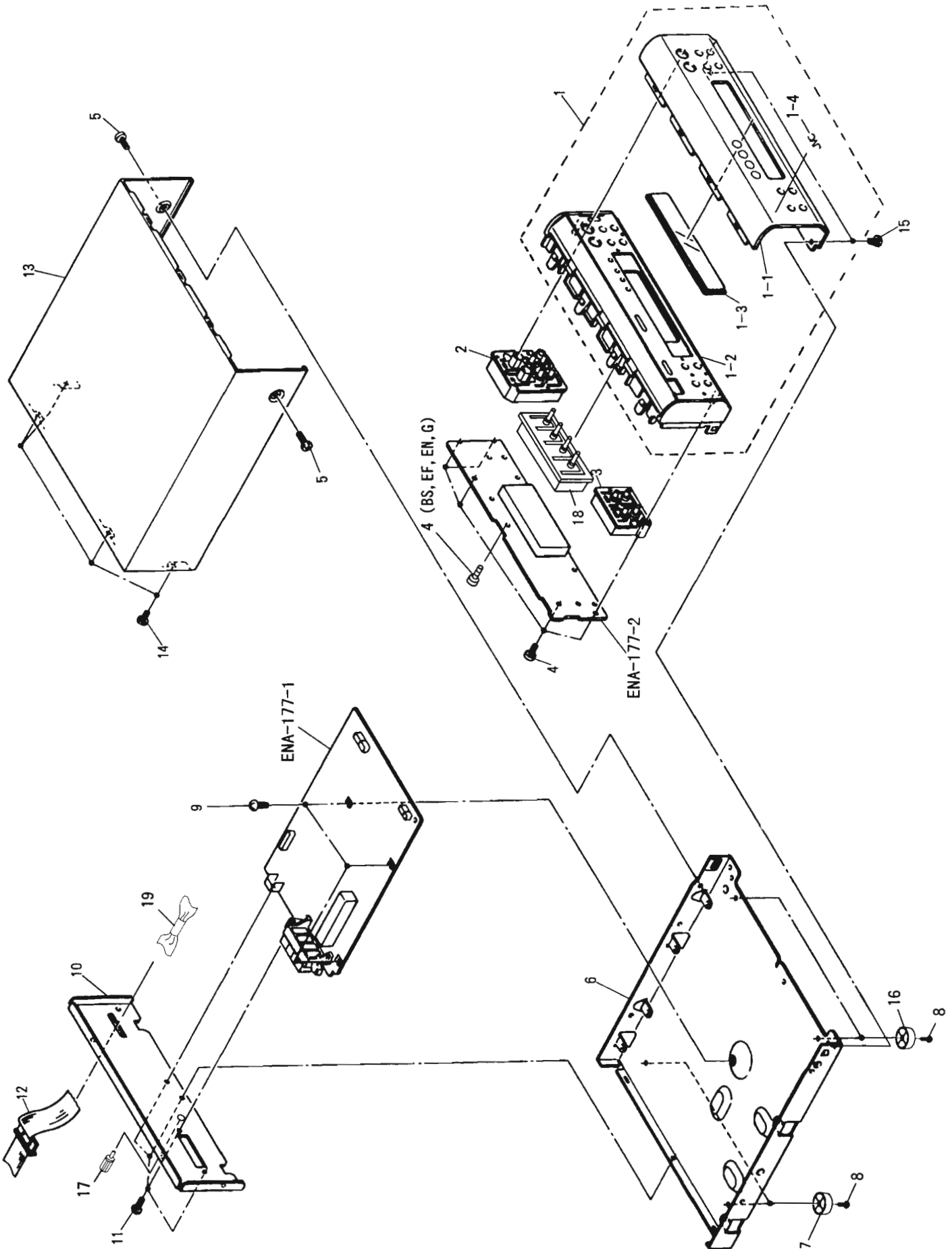

■ Parts List (FX-F3000)

Block No. **M7MM**

△	Item	Parts Number	Parts Name	Q'ty	Description	Area
	1	EFP-FXF3000U(S)	FRONT PANEL ASSY	1		
	1-1	E208739-002	FRONT PANEL	1		
	1-2	E103087-004ST	FRONT BASE	1		
	1-3	E309614-002	WINDOW SCREEN	1		
	1-4	E406971-221	JVC MARK	1		
	2	E208707-003SS	PUSH BUTTON ASSY	1		
	3	E309618-003SS	PUSH BUTTON	1		
	4	SDSF2608Z	SCREW	5		
	5	SDSG3008N	TAPPING SCREW	2		
	6	E102878-005	CHASSIS BASE	1		
	7	E75281-010	FOOT	2		
	8	SBST3010Z	TAPPING SCREW	4		
	9	SBST3006CC	TAPPING SCREW	3		
	10	E208705-007	REAR PANEL	1		J
		E208705-008	REAR PANEL	1		C
		E208705-010	REAR PANEL	1		U UB US UT
	11	E73273-003	SPECIAL SCREW	4		
	12	EWP907-018	FLAT WIRE ASSY	1		
	13	E208179-013(S)	METAL COVER	1		
	14	GBSG3008CC	TAPPING SCREW	4		
	15	SDSG3008CC	TAPPING SCREW	2		
	16	E75281-009	FOOT	2		
	17	E409257-001	EARTH TERMINAL	1		
	-	E61029-005	NUMBER LABEL	1		
		E75139-004	NAME LABEL	1		U

■ Parts List (FX-F3000R)

* Please see the parts list for FX-F3000 for parts which are not described.

△	Item	Parts Number	Parts Name	Q'ty	Description	Area
	1	EFP-FXF3000RE(S)	FRONT PANEL ASSY	1		
	1-1	E208739-003	FRONT PANEL	1		
	4	SDSF2608Z	SCREW	6		
	10	E208705-009	REAR PANEL	1		
	18	E310023-001SS	PUSH BUTTON	1	RDS	
	19	ENZ8104-005	NOISE FILTER	1		

■ Electrical Parts List (ENA-177)

△	Item	Parts Number	Description	Area
		I. C. S		
	IC102	LA1836M	I. C (MONO-ANALOG)	
	IC121	LC72131M	I. C (M)	
	IC191	LC7073M	I. C (DIGI-MOS)	BS EF EN G
	IC192	SAA6579T	I. C (M)	BS EF EN G
	IC201	MN172412K8M	I. C (MICRO-COMPUTER)	
	IC561	PST9146T	I. C (MONO-ANALOG)	
		DIODES		
	D121	1SS119	SI. DIODE	
	D125	1SS119	SI. DIODE	BS EF EN G
	D126	1SS119	SI. DIODE	
	D127	1SS119	SI. DIODE	BS EF EN G
	D128	1SS119	SI. DIODE	BS EF EN G
	D129	1SS119	SI. DIODE	
	D181	1SS119	SI. DIODE	
	D202	1SS119	SI. DIODE	
	D203	1SS119	SI. DIODE	
	D204	1SS119	SI. DIODE	
	D205	1SS119	SI. DIODE	BS EF EN G
	D206	1SS119	SI. DIODE	
	D211	SLR-342MCA47	L. E. D.	
	D212	SLR-342MCA47	L. E. D.	
	D221	1SS119	SI. DIODE	U UB US UT
	D222	1SS119	SI. DIODE	C J
	D271	1SS119	SI. DIODE	
	D562	1SS119	SI. DIODE	
	D821	1SS119	SI. DIODE	
	D822	1SS119	SI. DIODE	
	D856	MT28. 2JC	ZENER DIODE	
		TRANSISTORS		
	Q101	2SC461	SI. TRANSISTOR	
	Q102	2SC535	SI. TRANSISTOR	
	Q103	2SC461	SI. TRANSISTOR	
	Q111	2SD2144S (VM)	SI. TRANSISTOR	BS EF EN G
	Q112	2SD2144S (VM)	SI. TRANSISTOR	BS EF EN G
	Q113	2SD2144S (VM)	SI. TRANSISTOR	BS EF EN G
	Q114	2SD2144S (VM)	SI. TRANSISTOR	BS EF EN G
	Q121	DTA124ES	DIGITAL TRANSISTOR	
	Q122	DTA124ES	DIGITAL TRANSISTOR	
	Q123	DTA124ES	DIGITAL TRANSISTOR	BS EF EN G
	Q143	DTC114ES	DIGITAL TRANSISTOR	
	Q211	DTC114YS	DIGITAL TRANSISTOR	
	Q212	DTC114YS	DIGITAL TRANSISTOR	
	Q561	DTC114YS	DIGITAL TRANSISTOR	
	Q854	2SC2060 (Q. R)	SI. TRANSISTOR	
		CAPACITORS		
	C101	QCF21HP-103A	0. 01MF 50V CER. CAP.	
	C102	QETB1CM-107	100MF 16V AL. E. CAP.	
	C103	QCF21HP-223A	0. 022MF 50V CER. CAP.	
	C104	QCF21HP-223A	0. 022MF 50V CER. CAP.	
	C105	QCF21HP-223A	0. 022MF 50V CER. CAP.	
	C107	QCF21HP-223A	0. 022MF 50V CER. CAP.	
	C111	QCC21EM-223	0. 022MF 25V CER. CAP.	
	C112	QCT30CH-120Y	12PF 50V CER. CAP.	
	C113	QCHB1EZ-223	0. 022MF 25V CER. CAP.	BS EF EN G
	C117	QCSB1HK-5R6Y	5. 6PF 50V CER. CAP.	
	C118	QCSB1HJ-150Y	15PF 50V CER. CAP.	
	C121	QCT30CH-180Y	18PF 50V CER. CAP.	
	C122	QCT30CH-180Y	18PF 50V CER. CAP.	
	C123	QCC21EM-473	0. 047MF 25V CER. CAP.	
	C124	QCBB1HK-101Y	100PF 50V CER. CAP.	
	C128	QCBB1HK-101Y	100PF 50V CER. CAP.	
	C128	QENB1HM-474	0. 47MF 50V NP E. CAP.	
	C129	QCGB1HK-102	1000PF 50V CER. CAP.	
	C130	QETB1CM-227	220MF 16V AL. E. CAP.	
	C141	QCC21EM-473	0. 047MF 25V CER. CAP.	
	C142	QETB1HM-106	10MF 50V E. CAP.	
	C143	QCF21HP-223A	0. 022MF 50V CER. CAP.	
	C144	QCC21EM-223	0. 022MF 25V CER. CAP.	
	C145	QETB1HM-475E	4. 7MF 50V E. CAP.	

△	Item	Parts Number	Description	Area
	C146	QETB1HM-106	10MF 50V E. CAP.	
	C147	QETB1HM-105	1MF 50V AL. E. CAP.	
	C148	QETB1HM-474	0. 47MF 50V E. CAP.	
	C149	QETB1HM-105	1MF 50V AL. E. CAP.	
	C150	QETC1HM-225ZN	2. 2MF 50V AL. E. CAP.	
	C151	QCS21HJ-181A	180PF 50V CER. CAP.	BS EF EN G
	C152	QCS21HJ-181A	180PF 50V CER. CAP.	BS EF EN G
	C153	QCS31HJ-821Z	820PF 50V CER. CAP.	
	C154	QCXB1CM-472Y	4700PF 16V CER. CAP.	
	C155	QETB1EM-476	47MF 25V AL. E. CAP.	
	C156	QCHB1EZ-223	0. 022MF 25V CER. CAP.	
	C157	QCC21EM-473	0. 047MF 25V CER. CAP.	
	C158	QETB1HM-106	10MF 50V E. CAP.	
	C159	QFLB1HJ-333	0. 033MF 50V MYLAR CAP.	BS EF EN G
		QFLB1HJ-473	0. 047MF 50V MYLAR CAP.	C J U UB US UT
	C160	QFLB1HJ-333	0. 033MF 50V MYLAR CAP.	BS EF EN G
		QFLB1HJ-473	0. 047MF 50V MYLAR CAP.	C J U UB US UT
	C161	QETB1HM-225	2. 2MF 50V AL. E. CAP.	
	C162	QETB1HM-225	2. 2MF 50V AL. E. CAP.	
	C163	QCHB1EZ-223	0. 022MF 25V CER. CAP.	
	C168	QFV81HJ-274	0. 27MF 50V THIN FILM	
	C169	QFV81HJ-273	0. 027MF 50V THIN FILM	
	C181	QFN81HJ-562	5600PF 50V METAL. MYLA	
	C182	QFN81HJ-562	5600PF 50V METAL. MYLA	
	C184	QETB1CM-227	220MF 16V AL. E. CAP.	
	C185	QETB1HM-225	2. 2MF 50V AL. E. CAP.	
	C186	QETB1HM-225	2. 2MF 50V AL. E. CAP.	
	C187	QCBB1HK-331Y	330PF 50V CER. CAP.	BS EF EN G
	C188	QCBB1HK-331Y	330PF 50V CER. CAP.	BS EF EN G
	C191	QCBB1HK-820Y	82PF 50V CER. CAP.	BS EF EN G
	C192	QCSB1HJ-470	47PF 50V CER. CAP.	BS EF EN G
	C193	QCS31HJ-561Z	560PF 50V CER. CAP.	BS EF EN G
	C194	QCHB1EZ-223	0. 022MF 25V CER. CAP.	BS EF EN G
	C195	QCS31HJ-331Z	330PF 50V CER. CAP.	BS EF EN G
	C196	QETB1HM-225	2. 2MF 50V AL. E. CAP.	BS EF EN G
	C197	QETC1CM-106Z	10MF 16V AL. E. CAP.	BS EF EN G
	C198	QCC21EM-473	0. 047MF 25V CER. CAP.	BS EF EN G
	C199	QETB1HM-225	2. 2MF 50V AL. E. CAP.	BS EF EN G
	C201	QCSB1HJ-330Y	33PF 50V CER. CAP.	
	C207	QCVB1CM-103Y	0. 01MF 16V CER. CAP.	
	C210	QCVB1CM-103Y	0. 01MF 16V CER. CAP.	
	C211	QCVB1CM-103Y	0. 01MF 16V CER. CAP.	
	C217	QCZ0205-155	1. 5MF 25V C. CAP.	
	C221	QCBB1HK-331Y	330PF 50V CER. CAP.	
	C260	QETB1HM-225	2. 2MF 50V AL. E. CAP.	
	C261	QETB1HM-225	2. 2MF 50V AL. E. CAP.	
	C301	QCZ0205-155	1. 5MF 25V C. CAP.	BS EF EN G
	C303	QETB1CM-227	220MF 16V AL. E. CAP.	
	C561	QETB1HM-225	2. 2MF 50V AL. E. CAP.	
	C563	QCF21HP-473A	0. 047MF 50V CER. CAP.	
	C824	QEADOHZ-22AZM	E. CAP.	
	C861	QCF21HP-223A	0. 022MF 50V CER. CAP.	
	C862	QETB1CM-227	220MF 16V AL. E. CAP.	
	C863	QETB1EM-226N	22MF 25V E. CAP.	
	TC201	ENZ1003-015	0. 1MF TRIMMER CA	
		RESISTORS		
	R102	QRD167J-332	3. 3K 1/6W CARBON RE	
	R103	QRD161J-221	220 1/6W CARBON RE	
	R104	QRD167J-272	2. 7K 1/6W CARBON RE	
	R105	QRD161J-391	390 1/6W CARBON RE	
	R106	QRD161J-102	1K 1/6W CARBON RE	
	R107	QRD161J-561	560 1/6W CARBON RE	
	R108	QRD167J-332	3. 3K 1/6W CARBON RE	
	R109	QRD161J-221	220 1/6W CARBON RE	
	R110	QRD161J-472	4. 7K 1/6W CARBON RE	BS EF EN G
	R111	QRD161J-472	4. 7K 1/6W CARBON RE	BS EF EN G
	R112	QRD161J-472	4. 7K 1/6W CARBON RE	BS EF EN G
	R113	QRD161J-103	10K 1/6W CARBON RE	BS EF EN G
	R114	QRD161J-122	1. 2K 1/6W CARBON RE	BS EF EN G
	R115	QRD161J-104	100K 1/6W CARBON RE	

■ Electrical Parts List (ENA-177)

△	Item	Parts Number	Description	Area
	R116	QRD161J-472	4.7K 1/6W CARBON RE	BS EF EN G
	R119	QRD161J-103	10K 1/6W CARBON RE	
	R121	QRD161J-473	47K 1/6W CARBON RE	
	R122	QRD161J-472	4.7K 1/6W CARBON RE	
	R124	QRD161J-222	2.2K 1/6W CARBON RE	
	R127	QRD167J-822	8.2K 1/6W CARBON RE	
	R128	QRD161J-472	4.7K 1/6W CARBON RE	
	R129	QRD161J-222	2.2K 1/6W CARBON RE	
△	R130	QRD14CJ-680SX	68 1/4W UNF. CARBON	C J
△		QRZ0077-680	68 1/4W FUSIBLE RE	BS EF EN G U UB US UT
	R132	QRD161J-102	1K 1/6W CARBON RE	
	R133	QRD161J-473	47K 1/6W CARBON RE	
	R134	QRD161J-102	1K 1/6W CARBON RE	
	R141	QRD161J-392	3.9K 1/6W CARBON RE	
	R143	QRD161J-103	10K 1/6W CARBON RE	
	R144	QRD167J-332	3.3K 1/6W CARBON RE	
	R145	QRD161J-103	10K 1/6W CARBON RE	
	R146	QRD161J-222	2.2K 1/6W CARBON RE	
	R147	QRD161J-393	39K 1/6W CARBON RE	BS EF EN G U UB US UT
		QRD167J-223	22K 1/6W CARBON RE	C J
	R148	QRD161J-561	560 1/6W CARBON RE	
	R149	QRD161J-103	10K 1/6W CARBON RE	EF EN G
		QRD167J-223	22K 1/6W CARBON RE	BS C J U UB US UT
	R161	QRD161J-122	1.2K 1/6W CARBON RE	
	R162	QRD161J-122	1.2K 1/6W CARBON RE	
	R163	QRD161J-472	4.7K 1/6W CARBON RE	EF EN G
		QRD167J-332	3.3K 1/6W CARBON RE	BS C J U UB US UT
	R164	QRD161J-472	4.7K 1/6W CARBON RE	EF EN G
		QRD167J-332	3.3K 1/6W CARBON RE	BS C J U UB US UT
	R165	QRD167J-152	1.5K 1/6W CARBON RE	BS C J U UB US UT
	R166	QRD167J-152	1.5K 1/6W CARBON RE	BS C J U UB US UT
	R175	QRD161J-101	100 1/6W CARBON RE	
	R176	QRD161J-101	100 1/6W CARBON RE	
	R182	QRD161J-103	10K 1/6W CARBON RE	
	R183	QRD161J-103	10K 1/6W CARBON RE	
	R184	QRD161J-103	10K 1/6W CARBON RE	
	R188	QRD161J-103	10K 1/6W CARBON RE	
	R189	QRD161J-472	4.7K 1/6W CARBON RE	
	R191	QRD161J-222	2.2K 1/6W CARBON RE	BS EF EN G
	R201	QRD161J-472	4.7K 1/6W CARBON RE	
	R203	QRD161J-472	4.7K 1/6W CARBON RE	
	R204	QRD161J-472	4.7K 1/6W CARBON RE	
	R205	QRD161J-472	4.7K 1/6W CARBON RE	
	R206	QRD161J-472	4.7K 1/6W CARBON RE	
	R211	QRD167J-151	150 1/6W CARBON RE	
	R212	QRD167J-151	150 1/6W CARBON RE	
	R221	QRD161J-102	1K 1/6W CARBON RE	
	R222	QRD161J-102	1K 1/6W CARBON RE	
	R231	QRD161J-102	1K 1/6W CARBON RE	
	R241	QRD161J-221	220 1/6W CARBON RE	
	R565	QRD161J-102	1K 1/6W CARBON RE	
	R566	QRD161J-102	1K 1/6W CARBON RE	
	R852	QRD161J-102	1K 1/6W CARBON RE	
		OTHERS		
		EMW10653-002	PRINTED BOARD	
	L111	EQL4007-150T	INDUCTOR	
	L141	EQL2108-392	INDUCTOR	BS EF EN G
	L191	EQL4007-101	INDUCTOR	BS EF EN G
	S201	ESPO001-023M	TACT SWITCH	
	S202	ESPO001-023M	TACT SWITCH	
	S203	ESPO001-023M	TACT SWITCH	
	S204	ESPO001-023M	TACT SWITCH	
	S205	ESPO001-023M	TACT SWITCH	
	S206	ESPO001-023M	TACT SWITCH	
	S207	ESPO001-023M	TACT SWITCH	
	S208	ESPO001-023M	TACT SWITCH	
	S209	ESPO001-023M	TACT SWITCH	
	S210	ESPO001-023M	TACT SWITCH	
	S211	ESPO001-023M	TACT SWITCH	BS EF EN G
	S212	ESPO001-023M	TACT SWITCH	BS EF EN G

△	Item	Parts Number	Description	Area
	S213	ESPO001-023M	TACT SWITCH	BS EF EN G
	S214	ESPO001-023M	TACT SWITCH	BS EF EN G
	T111	EQR7121-002	RF COIL	BS EF EN G
		EQR7121-004	RF COIL	C J U UB US UT
	T141	EQT2140-021	I. F. TRANSFORMER	
	T142	ECB1560-012	CERAMIC FILTER	
	X121	ECX0007-200KWJ1	CRYSTAL	
	X141	ECXPR46-001A	CRYSTAL	
	X191	VCX5057-001	CRYSTAL	BS EF EN G
	X192	EFO-EC4004T4	CERAMIC RESONATOR	BS EF EN G
	X201	ECX0006-000KNJ	CRYSTAL	
	AT101	EMB41YV-302K	ANTENNA TERMINAL	
	BK001	E308963-002	SHIELD BRACKET	
	CF101	ECB2118-007R	CERAMIC FILTER	BS EF EN G
		ECB2123-006R	CERAMIC FILTER	C J U UB US UT
	CF102	ECB2118-007R	CERAMIC FILTER	BS EF EN G
		ECB2123-006R	CERAMIC FILTER	C J U UB US UT
	CN101	EMV7141-011	CONNECT TERMINAL	
	D1201	ELU0001-205	FLUORESCENT DISPLAY TUB	
	EP101	E70225-003SS	EARTH PLATE	
	EP102	EMZ4002-002Z	EARTH PLATE	
	EP103	EMZ4002-002Z	EARTH PLATE	
	EP104	EMZ4002-002Z	EARTH PLATE	
	FL141	EQF0101-012	LOWPASS FILTER	
	FL142	EQF0101-012	LOWPASS FILTER	
	FS101	E306805-191	SPACER	
	FS102	E306805-191	SPACER	
	FW102	EWR38D-16LS	FLAT WIRE ASSY	
	FW103	EWR34D-16LS	FLAT WIRE ASSY	
	FW104	EWR39D-16LS	FLAT WIRE ASSY	
	JT101	EMV7145-004Z	SOCKET ASSY	
	JT102	EMV7145-004Z	SOCKET ASSY	
	JT103	EMV7145-004Z	SOCKET ASSY	
	JT104	EMV7145-005Z	SOCKET ASSY	
	JT105	EMV7145-004Z	SOCKET ASSY	
	RF101	EAF2203-005	FRONT END	BS EF EN G
		EAF2207-001	FRONT END	C J U UB US UT
	SP102	VYH7653-002	I. C. SOCKET	
	SP121	VYH7653-004	I. C. PROTECTOR	
	SP191	VYH7653-004	I. C. PROTECTOR	BS EF EN G
	SP192	VYH7653-009	I. C. HOLDER	BS EF EN G
	SP201	VYH7653-001	SPRING	

Accessories List

Block No. **M8MM**

△	Item	Parts Number	Parts Name	Q'ty	Description	Area
△	1	E30580-2516A	INSTRUCTION BOOK	1		J
△		E30580-2517A	INSTRUCTION BOOK	1		C
△		E30580-2518A	INSTRUCTION BOOK	1		EF G
△		E30580-2519A	INSTRUCTION BOOK	1		EN
△		E30580-2520A	INSTRUCTION BOOK	1		U UB US UT
△		E30580-2521ABS	INSTRUCTION BOOK	1		BS
	2	E43486-696A	CAUTION SHEET	1		
	3	E309758-003	ENVELOPE	1		
	4	BT-51006-1	REGISTER CARD	1		J
	5	BT-20134	WARRANTY CARD	1		G
		BT-52002-1	WARRANTY CARD	1		C
		BT-54003-1	WARRANTY CARD	1		BS
	6	BT-20071B	SERVICE NETWORK	1		C
	7	BT-20066A	DISTRIBUTOR LIST	1		BS
	8	BT-20044G	SAFETY SHEET	1		J
		E43486-340A	SAFETY SHEET	1		BS
	9	RM-SEF3000RU	WIRE-LESS REMOTE CONTROL	1		BS EF EN G
		RM-SEF3000U	WIRE-LESS REMOTE CONTROL	1		C J U UB US UT
	10	R03BPA-2STSA	BATTERY	1		
	11	EQB4001-015	LOOP ANTENNA	1		
	12	EWP503-001	ANTENNA WIRE	1		BS EF EN G
	13	E03614-004	FM FEEDER ANTENNA	1		C J U UB US UT
	14	EMZ2001-014	ADAPTOR	1		C J U UB US UT
	15	EWPZ01-012	EARTH WIRE	1		BS EF EN G
		EWPZ01-015	EARTH WIRE	1		C J U UB US UT
	16	ENZ2202-001	SIEMENS PLUG	1		US
		ENZ2203-001	SIEMENS PLUG	1		U UT

CA-F3000

Packing Materials and Part Numbers

Block No. **M9MM**

- For U, UB, US, UT, J and C -

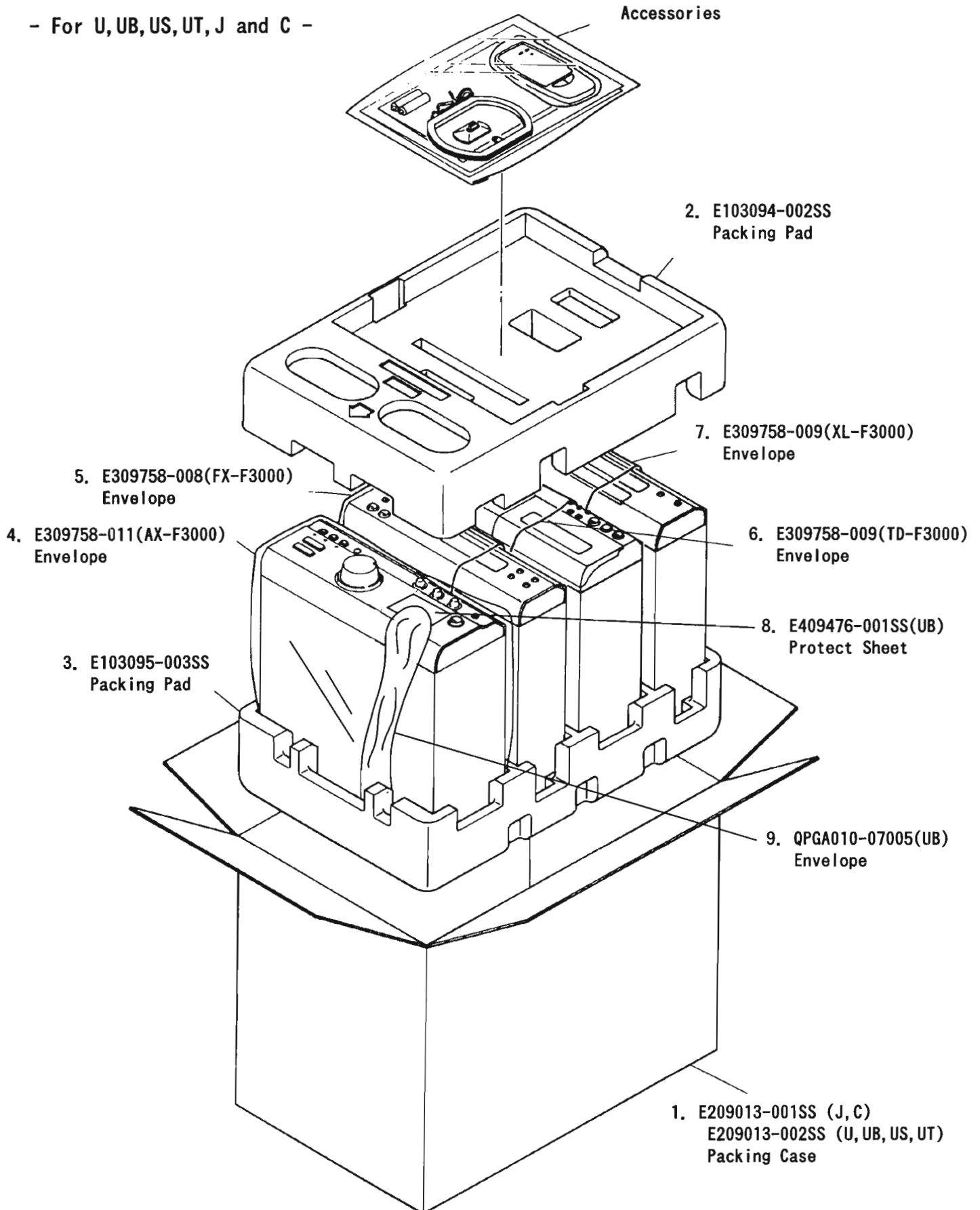

Packing Materials and Part Numbers

Block No. **M T Q M M**

- For BS, EF, EN and G -

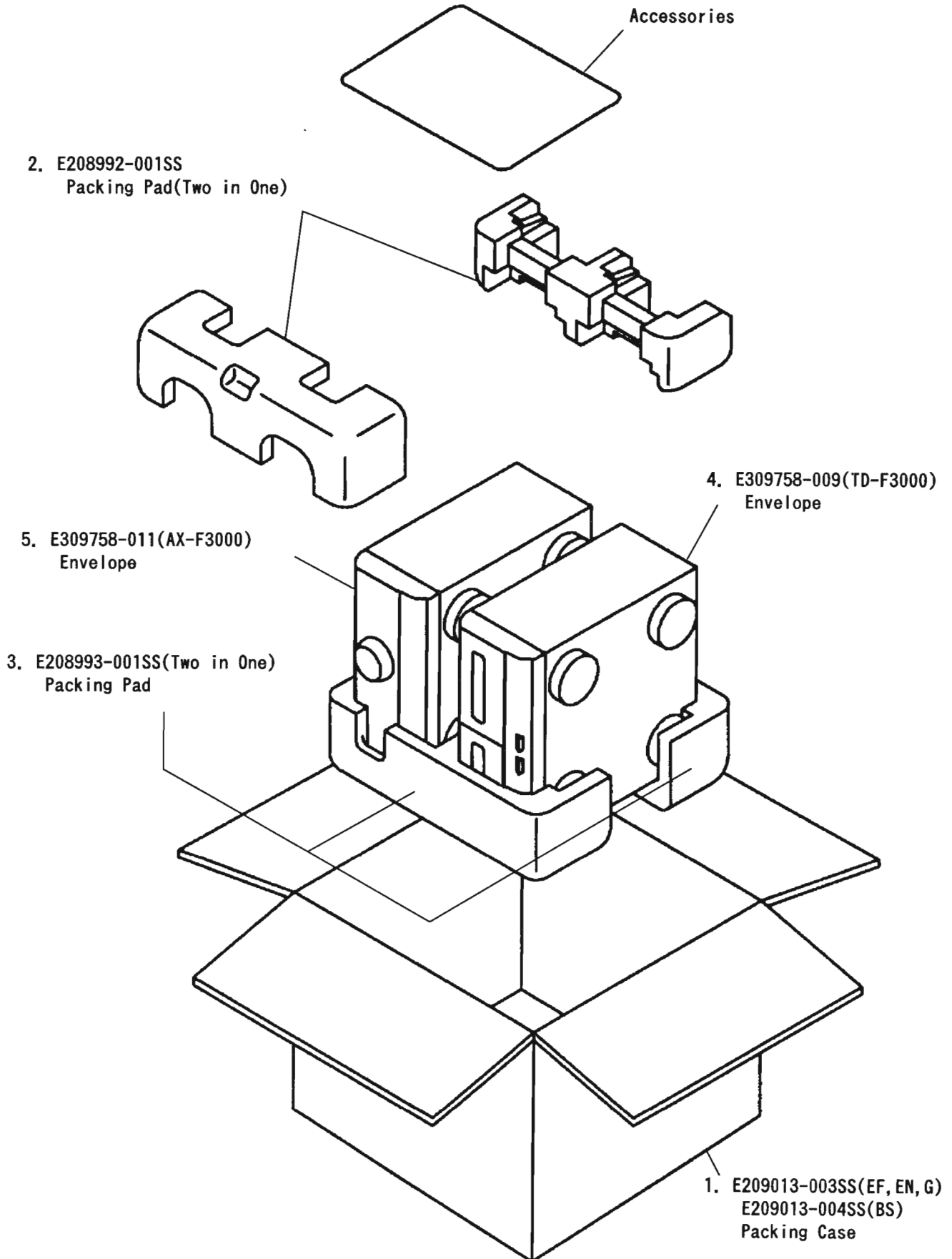

Description of Major LSIs

■ HD614081SE39 (IC203) : Deck controller

Terminal Layout

NR LED	1	64	A.FWD. LED
NR LED(C)	2	63	A. REV. LED
A SPEED UP	3	62	B FWD. LED
B SPEED UP	4	61	B.REV. LED
MUSIC IN	5	60	REC LED
B.FWD.REEL MOTOR	6	59	REV. MODE
B.REV.REEL MOTOR	7	58	BIAS
B REV CAM MOTOR	8	57	NR OFF
B FWD CAM MOTOR	9	56	REC MUTE
A CAM SW-2	10	55	DCS IN
A CAM SW-1	11	54	DCS OUT
A CAM SW-0	12	53	GND
A PULSE IN	13	52	4.19MHzOSC IN
B CAM SW-2	14	51	4.19MHzOSC IN
B CAM SW-1	15	50	TO VCC
B CAM SW-0	16	49	RESET IN
B PULSE IN	17	48	KEY&SW IN-4
POWER OFF IN	18	47	KEY&SW IN-3
GND	19	46	KEY&SW IN-2
A FWD REEL MOTOR	20	45	KEY&SW IN-1
A REV REEL MOTOR	21	44	KEY OUT-4
A REV CAM MOTOR	22	43	KEY OUT-3
A FWD CAM MOTOR	23	42	KEY OUT-2
NR REC	24	41	KEY OUT-1
A MUTE	25	40	SWOUT-2
B MUTE	26	39	SWOUT-1
PLAY MUTE	27	38	HI-SPEED DUBBING
CAP.MOTOR ON	28	37	H.S.CrO2
REC	29	36	H.S. ME
FADE CTRL.	30	35	H.S.NORM.
BEQ	31	34	CrO2
+5V	32	33	METAL

Key matrix

	KEY&SW-1 (PIN45)	KEY&SW-2 (PIN46)	KEY&SW-3 (PIN47)	KEY&SW-4 (PIN48)
KEY OUT 1 (PIN41)	A ◀ (S300)	A ◀◀ (S301)	A ▶▶ (S302)	A ▶ (S303)
KEY OUT 2 (PIN42)	B ◀ (S310)	B ◀◀ (S311)	B ▶▶ (S312)	B ▶ (S313)
KEY OUT 3 (PIN43)	A ■ (S320)	B ■ (S321)	REC PAUSE (S322)	—
KEY OUT 4 (PIN44)	A▶▶B (S330)	DOLBY (S331)	REV. MODE (S332)	CD REC (S333)
SW OUT 1 (PIN39)	—	B CrO2	METAL	—
SW OUT 2 (PIN40)	B PACK	REV REC	FWD REC	A PACK

Terminal Description

Pin NO.	Symbol	I/O	Function	Pin NO.	Symbol	I/O	Function
1	NR LED	O	Dolby B indicator signal output	33	METAL	O	Metal tape , normal speed record
2	NR LED(C)	O	Dolby C indicator signal output	34	CrO ₂	O	CrO ₂ tape , normal speed record
3	A S UP	O	Reel speed up control (Deck A)	35	HS NORM	O	Not used
4	B S UP	O	Reel speed up control (Deck B)	36	HS METAL	O	Metal tape , high speed record
5	MUSIC IN	I	Music scan signal input	37	HS CrO ₂	O	CrO ₂ tape , high speed record
6	B F R M	O	Reel control signal for forward (Deck B)	38	HI DUB	O	Not used
7	B R R M	O	Reel control signal for reverse (Deck B)	39	SW O1	O	Keypad output for leaf switch
8	B R C M	O	Cam control signal for reverse (Deck B)	40	SW O2	O	Keypad output for leaf switch
9	B F C M	O	Cam control signal for forward (Deck B)	41	KEY O1	O	Key matrix output
10	A C SW2	I	Cam data input	42	KEY O2	O	Key matrix output
11	A C SW1	I	Cam data input	43	KEY O3	O	Key matrix output
12	A C SW0	I	Cam data input	44	KEY O4	O	Key matrix output
13	A.PULS IN	I	Reel pulse input from deck A	45	KEY/SW 11	I	Key matrix input
14	B C SW2	I	Cam data input	46	KEY/SW 12	I	Key matrix input
15	B C SW1	I	Cam data input	47	KEY/SW 13	I	Key matrix input
16	B C SW0	I	Cam data input	48	KEY/SW 14	I	Key matrix input
17	B.PULSE IN	I	Reel pulse input from deck B	49	RESET	I	Reset input
18	P.CONT	I	Inhibit input from system controller	50	TO VCC	--	Connected to VCC
19	GND	--	GND	51	OSC	--	Oscillation terminal
20	A F R M	O	Reel control signal for forward (Deck A)	52	OSC	--	Oscillation terminal
21	A R R M	O	Reel control signal for reverse (Deck A)	53	GND	--	GND
22	A R C M	O	Cam control signal for reverse (Deck A)	54	DCS OUT	O	Compulink output
23	A F C M	O	Cam control signal for forward (Deck A)	55	DCS IN	I	Compulink input
24	NR REC	O	It is "H" when recording with NR on	56	REC MUTE	O	Recording mute control
25	A MUTE	O	It is "H" when deck A is not playing	57	NR OFF	O	NR on/off control
26	B MUTE	O	It is "H" when deck B is not playing	58	BIAS	O	Bias on/off control
27	PLAY MU	O	Deck mute	59	REV MODE	O	Indication control for reverse mode
28	CAP CONT	O	Capstan on/off control	60	REC LED	O	Indication control for record
29	REC	O	It is "H" when recording	61	BREV LED	O	Indication control for reverse playback
30	FADE CON	O	It is "H" when recording with fade	62	BFWD LED	O	Indication control for forward playback
31	BEQ	O	It is "L" when CrO ₂ tape is in deck B	63	AREV LED	O	Indication control for reverse playback
32	+5V	--	Power supply	64	AFWD LED	O	Indication control for forward playback

CA-F3000

JVC

VICTOR COMPANY OF JAPAN, LIMITED

AUDIO PRODUCT DIVISION, 1644, SHIMOTSURUMA, YAMATO-SHI, KANAGAWA-KEN, 242, JAPAN

(No. 20590U)



Printed in Japan
9607(5)