

JVC

SERVICE MANUAL

COMPACT COMPONENT SYSTEM

MODEL No. **DX-MX70BK**
CA-MX70BK
 (UNIT No. AX-MX70BK)

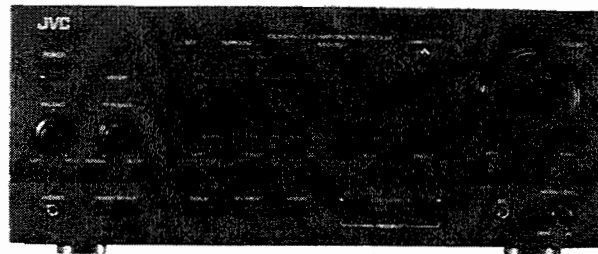

* Refer to the CA-MX70BK (S.M. No. 20243) or DX-MX70BK (S.M. No. 20249) as instruction manual.

Contents

	Page		Page
Safety Precautions	1-2	Schematic Diagrams	Insertion
Air-cooling Fan	1-3	Printed Circuit Board	Insertion
Disassembly Procedures	1-4	Block Diagrams	Insertion
Description of Major LSIs	1-5	Connection Diagram	Insertion
Internal Connections for the Display Tube	1-11	Parts List	Insertion

Safety Precautions

1. The design of this product contains special hardware and many circuits and components specially for safety purposes. For continued protection, no changes should be made to the original design unless authorized in writing by the manufacturer. Replacement parts must be identical to those used in the original circuits. Services should be performed by qualified personnel only.
2. Alterations of the design or circuitry of the product should not be made. Any design alterations of the product should not be made. Any design alterations or additions will void the manufacturer's warranty and will further relieve the manufacture of responsibility for personal injury or property damage resulting therefrom.
3. Many electrical and mechanical parts in the products have special safety-related characteristics. These characteristics are often not evident from visual inspection nor can the protection afforded by them necessarily be obtained by using replacement components rated for higher voltage, wattage, etc. Replacement parts which have these special safety characteristics are identified in the Parts List of Service Manual. Electrical components having such features are identified by shading on the schematics and by (Δ) on the Parts List in the Service Manual. The use of a substitute replacement which does not have the same safety characteristics as the recommended replacement parts shown in the Parts List of Service Manual may create shock, fire, or other hazards.
4. The leads in the products are routed and dressed with ties, clamps, tubings, barriers and the like to be separated from live parts, high temperature parts, moving parts and/or sharp edges for the prevention of electric shock and fire hazard. When service is required, the original lead routing and dress should be observed, and it should be confirmed that they have been returned to normal, after re-assembling.
5. Leakage current check (Electrical shock hazard testing)
After re-assembling the product, always perform an isolation check on the exposed metal parts of the product (antenna terminals, knobs, metal cabinet, screw heads, headphone jack, control shafts, etc.) to be sure the product is safe to operate without danger of electrical shock.

Do not use a line isolation transformer during this check.

- Plug the AC line cord directly into the AC outlet. Using a "Leakage Current Tester", measure the leakage current from each exposed metal parts of the cabinet, particularly any exposed metal part having a return path to the chassis, to a known good earth ground. Any leakage current must not exceed 0.5mA AC (r.m.s.).

● Alternate check method

Plug the AC line cord directly into the AC outlet. Use an AC voltmeter having, 1,000 ohms per volt or more sensitivity in the following manner. Connect a 1,500 Ω 10 W resistor paralleled by a 0.15 μ F AC-type capacitor between an exposed metal part and a known good earth ground.

Measure the AC voltage across the resistor with the AC voltmeter.

Move the resistor connection to each exposed metal part, particularly any exposed metal part having a return path to the chassis, and measure the AC voltage across the resistor.

Now, reverse the plug in the AC outlet and repeat each measurement. Any voltage measured must not exceed 0.75 V AC (r.m.s.). This corresponds to 0.5 mA AC (r.m.s.).

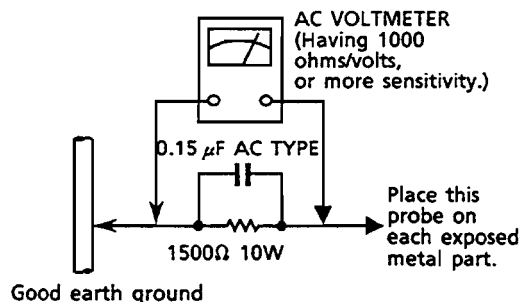

Warning

1. This equipment has been designed and manufactured to meet international safety standards.
2. It is the legal responsibility of the repairer to ensure that these safety standards are maintained.
3. Repairs must be made in accordance with the relevant safety standards.
4. It is essential that safety critical components are replaced by approved parts.
5. If mains voltage selector is provided, check setting for local voltage.

Air-cooling Fan

(1) Outline:

By using an air blower with a motor in the AX-MX70BK, the heat sink has been made smaller and high power has been achieved in a compact format. The air blower rotates with a 2-step speed according to the music signal level. The rise of the temperature in the heat sink is detected by a thermistor, and if the temperature becomes abnormal, the speaker relay is turned OFF.

(2) Operation principle:

The music signal level detected by the A/D converter (IC093) is input to the microcomputer, and the fan motor is driven with a 2-step speed according to that signal level. The temperature of the heat sink is detected by the resistance value of the thermistor (SR041), and is input to the A/D converter (IC093).

(3) Fan operation (standard value)

- ① When the speaker output continues for more than 1 minute (continuously more than 4 V or at a music peak above 10 V), the rotation speed is lowered.
- ② When the condition of ① continues for more than 15 minutes, the rotation speed is raised.
- ③ When the signal detection is turned OFF while the fan is rotating, the fan will be stopped after 1 minute.
- ④ When condition ② continues, the rotation is stopped for 2 minutes after 30 minutes and, thereafter, high speed rotation will continue.

(4) Abnormal rise in temperature (standard value)

When the temperature of the heat sink is higher than 125°C for more than a minute, the speaker relay is turned OFF.

Check of Fan Motor Rotation

- ① Short-circuit of W049 and GND → Low speed rotation
- ② Short-circuit of W050 and GND → High speed rotation

Disassembly Procedures

(1) Removing the top cover

1. Remove the screw on each side and the 4 screws on the rear.
2. Pull the top cover slightly backward and lift it while spreading the backs of the left and right sides to remove it.

(2) Removing the Front panel

1. Remove the top cover.
2. Remove the 5 screws under the front panel

(3) Confirming the Main P.C. board

1. Remove the top cover.
2. Remove the 6 screws ①②③ fastening the main P.C.board and heat sink bracket.(Fig.1)
3. Remove the screw ⑤ fastening the rear side.(Fig.2)
4. Confirm the main P.C. board as shown in the Fig.3

(4) Removing the Heat Sink.

1. Remove the top cover.
2. Remove the 2 screws ② fastening the heat sink.
3. Remove the 4 screws ③④ fastening the heat sink bracket.
4. Pull out the heat sink Ass'y from main P.C. board.

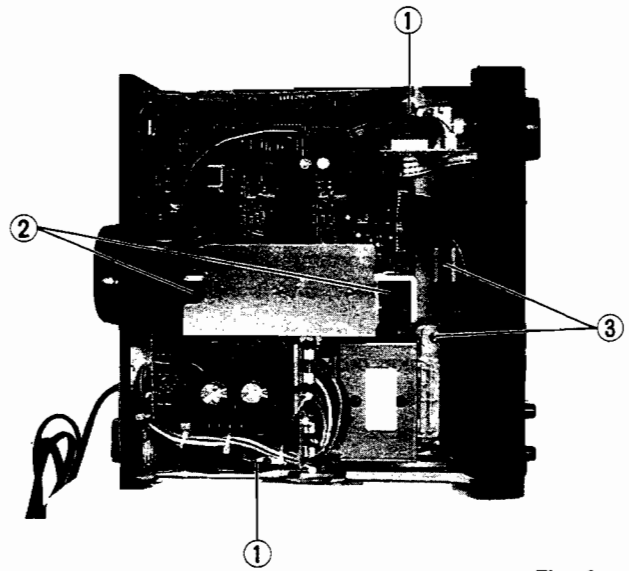

Fig. 1

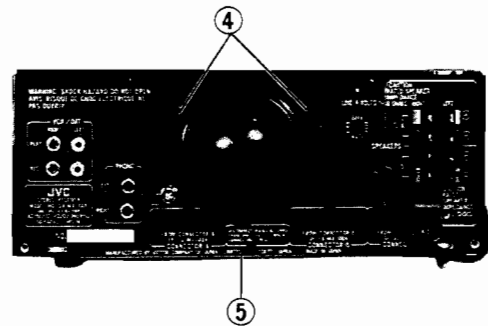

Fig. 2

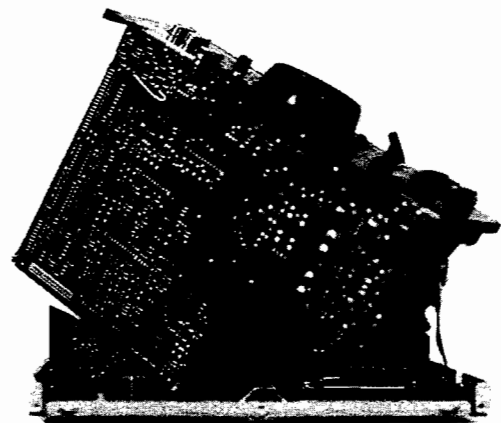

Fig. 3

Description of Major LSIs

■ MN171202JNY (IC901)..... System Control Microcomputer

1. Terminal Layout

Vcc	1	64	OSC2
S1	2	63	OSC1
S2	3	62	Vss
S3	4	61	
S4	5	60	X1
S5	6	59	D
S6	7	58	C
S7	8	57	B
S8	9	56	A
S9	10	55	G2 DIGIT1
S10	11	54	CS DCM/EXP
S11	12	53	STANDBY
S12	13	52	
S13	14	51	FL OFF
S14	15	50	MUTING
AI IND	16	49	POWER ON/OFF
VOL. IND	17	48	DCS OUT
Vpp	18	47	DCS IN
VOL. UP	19	46	INH
VOL. DOWN	20	45	REMOCON IN
	21	44	PROTECT IN
SURROUND	22	43	RESET
ENG. ON/OFF	23	42	A/D SO
ENG. SPEED	24	41	A/D SI
SPK. OUT	25	40	A/D SCK
AC RELAY	26	39	G
KI0	27	38	SW SO
KI1	28	37	SW STB
KI2	29	36	SW SCK
KI3	30	35	A/D STB
CLOCK	31	34	A/D CS
DATA	32	33	RCK(STB)

2. Pin Functions

Pin No.	Name	I/O	Function	Pin No.	Name	I/O	Function
1	Vcc	—	Power supply voltage(+ 5V).	39	G	O	Output control signal to IC905.
2~15	S1~S14	O	FL segment control output.	40	A/D SCK	O	Clock signal output to IC093,IC094 and IC905.
16	AI IND	O	AI indicator signal output.	41	A/D SI	I	Serial data input from IC093.
17	VOL. IND	O	Volume indicator signal output.	42	A/D SO	O	Clock signal output to IC093 and IC094.
18	Vpp	—	Power supply for FL display.	43	RESET	I	Reset signal input.
19	VOL. UP	O	Volume up signal output.	44	PROTECT IN	I	Protector detect signal input.
20	VOL.DOWN	O	Volume down signal output.	45	REMOCON IN	I	Remocon signal input.
21			Non connect.	46	INH	I	INH signal input.
22	SURROUND	O	Surround control signal output.	47	DCS IN	I	DCS signal input.
23	ENG. ON/OFF	O	FAN on/off control signal output.	48	DCS OUT	O	DCS signal output.
24	ENG. SPEED	O	FAN speed control signal output.	49	POW. ON/OFF	O	Outputs power on/off signal to mech. control.
25	SPK.OUT	O	Speaker relay control signal output.	50	MUTING	O	Muting signal output.
26	AC RELAY	O	AC relay control signal output.	51	FL OFF	O	FL display control signal output.
27~30	KI0~KI3	I	Key matrix input.	52			Non connect.
31	CLOCK	O	Clock signal output to IC641.	53	STANDBY	O	STANDBY indicator signal output.
32	DATA	O	Data signal output to IC641.	54	CS DCM/EXP	I	Pull down.
33	RCK(STB)	O	Stb signal output to IC905.	55	G2 DIGIT1	O	FL grid control signal.
34	A/D CS	O	Chip select signal output to IC093.	56~59	A~D	O	FL grid control signal.
35	A/D STB	O	Stb signal output to IC094.	60	X1	I	Pull down.
36	SW SCK	O	Clock signal output to IC601.	61			Non connect.
37	SW STB	O	Stb signal output to IC601.	62	Vss	—	GND.
38	SW SO	O	Data signal output to IC601.	63 - 64	OSC1 - OSC2	—	clock oscillation.

■ TC9163N, TC9164N (IC601, 094) : Analog Switch

1. Functions

These analog switches are controlled by 14 bit serial data from computer for selecting the source.

2. Terminal Layout & Block diagram

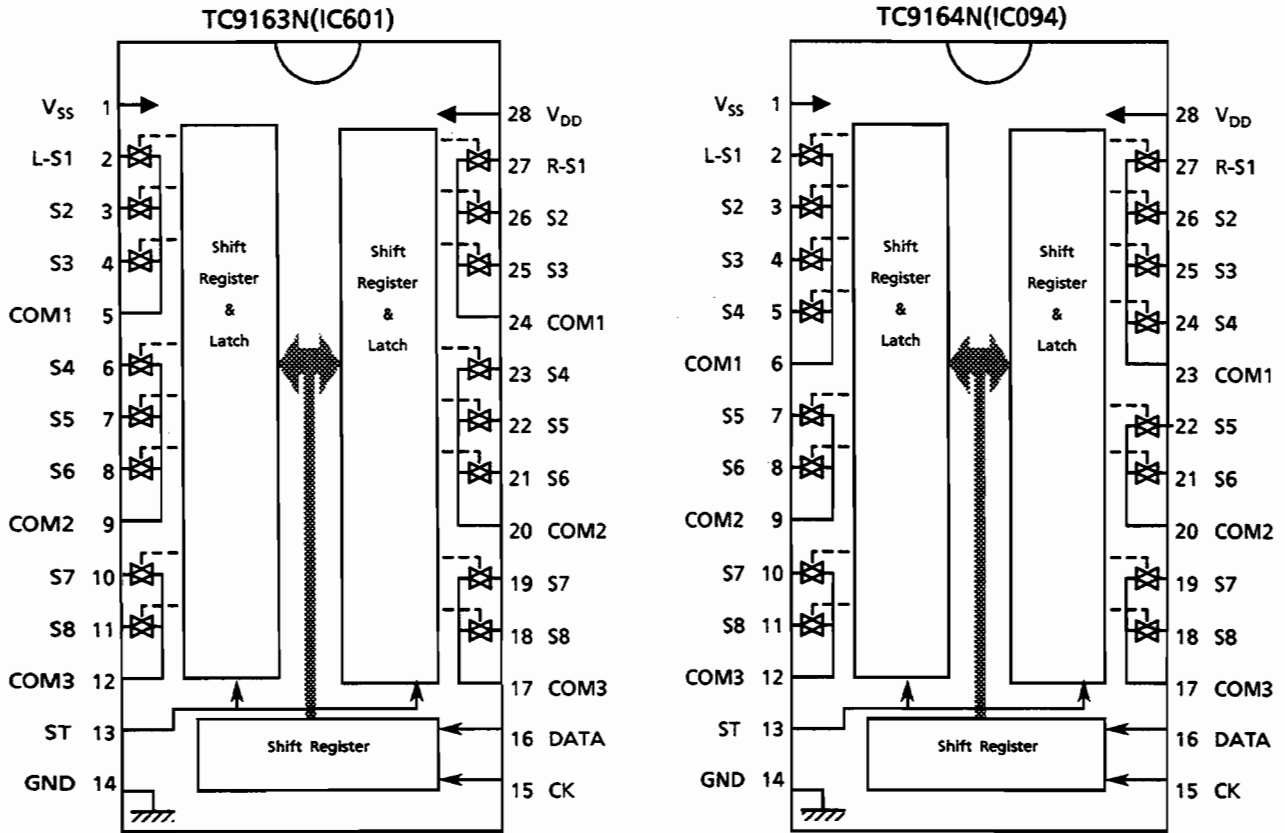

3. First 10bits are used to source select. Last 4 bits are chip select. The switches (S1~S8) are connected to common terminals (COM1~COM3) according to the DATA from computer.

	Switch Select bit								CH1 CH2 (L-S1~S8)(R-S1~S8)		Chip Select bit			
	S1	S2	S3	S4	S5	S6	S7	S8	S9	S10	S11	S12	S13	S14
TC9163N	The switch is ON when the data is "1".										1	0	0	0
TC9164N											0	1	0	0

■ IC641 : LC7522 (Variable Resistor for SEA Control)

- (1) Terminal Layout (2) Block Diagram

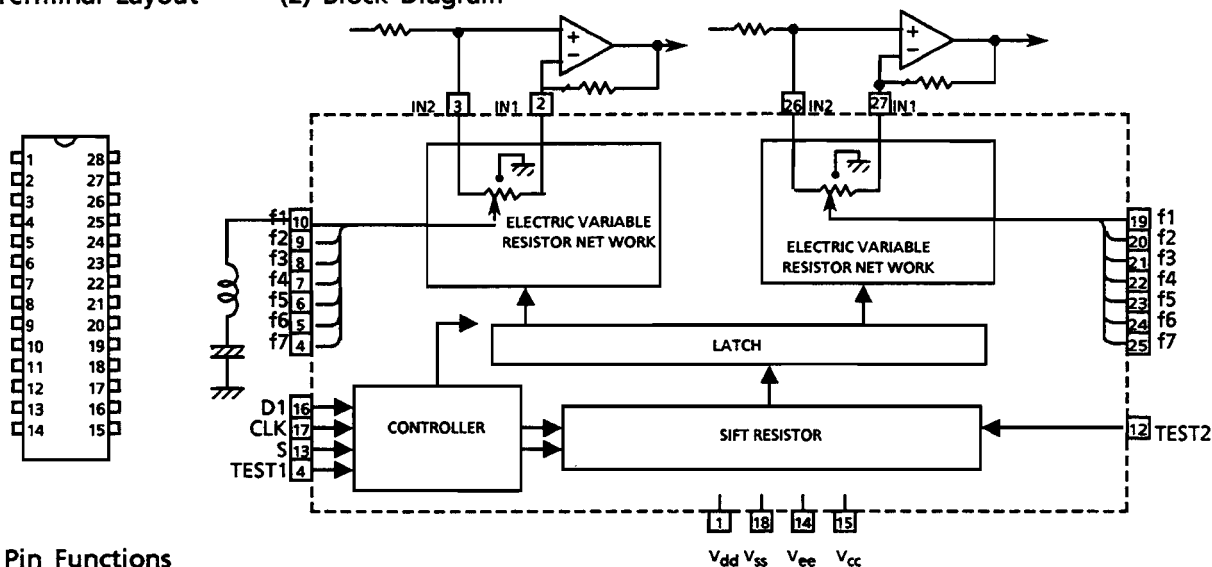

(3) Pin Functions

Pin No.	Pin Name	Functions
1	V _{DD}	Power supply +7V for audio signal
18	V _{SS}	Ground.
14	V _{EE}	Power supply -7V for audio signal.
15	V _{CC}	Power supply +5V
2,27	IN 1	Audio signal input
3, 26	IN 2	The inversion signal of the operational amplifier inputs to IN 1 normally. The non-inversion signal of the operational amplifier inputs to IN 2 normally.
16	DI	Data input from the CPU. Schmitt inverter type
17	CLK	Clock signal input from the CPU. Schmitt inverter type
4~10 19~25	f1~f7	For connect to band-pass filter. f1~f7x2 (Left and Right)
11	TEST 1	Not use
12	TEST 2	Not use
13	S	Chip Select
28	NC	Not use

■ LA3607S (IC643,IC644) : S.E.A. GRAPHIC EQUALIZER

1. Functions

It makes inductive characteristic instead of coil.

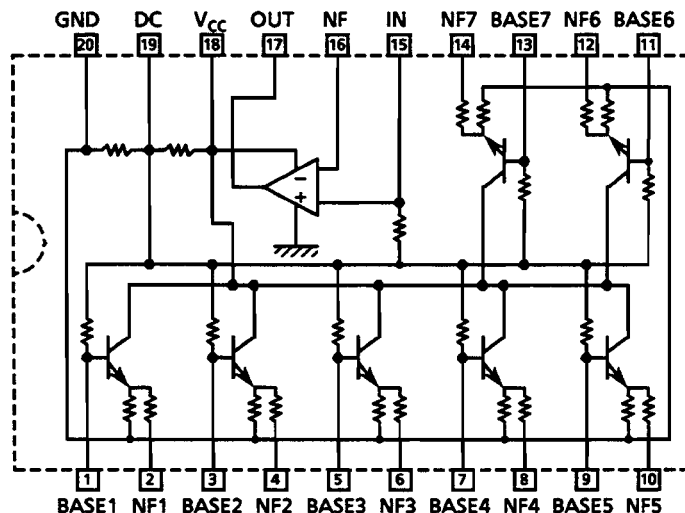

■ LB1639-CV (IC972) : Motor Driver

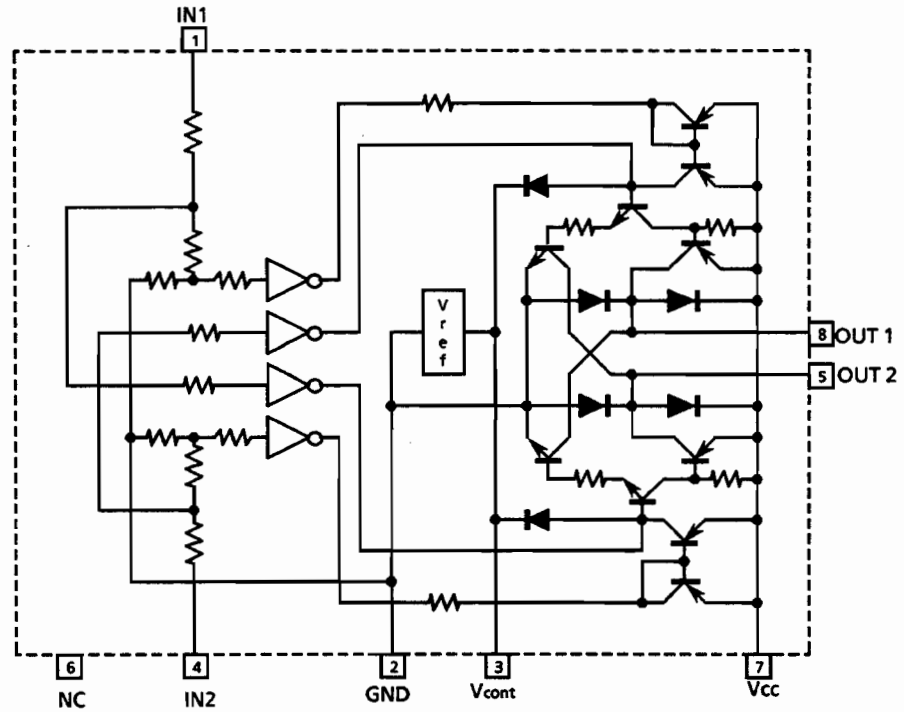

IN 1	IN 2	OUT 1	OUT 2	MOTOR
H	L	H	L	CLOCKWISE
L	H	L	H	COUNTER-CLOCKWISE
H	H	OFF	OFF	WAITING
L	L	OFF	OFF	WAITING

■ GP1U501X (IC906) : Receiver for remote controller

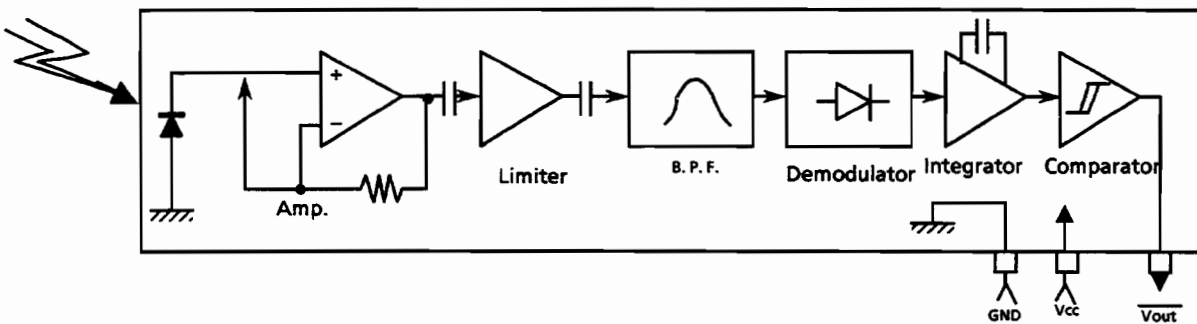

■ XR1091DCP (IC095) : Display Filter

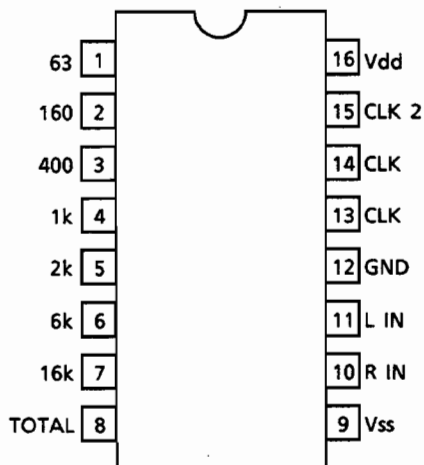

Pin No.	Symbol	Descriptions
1	63	Peak hold output of 63Hz band-pass filter
2	160	Peak hold output of 160Hz band-pass filter
3	400	Peak hold output of 400Hz band-pass filter
4	1k	Peak hold output of 1kHz band-pass filter
5	2k	Peak hold output of 2kHz band-pass filter
6	6k	Peak hold output of 6kHz band-pass filter
7	16k	Peak hold output of 16Hz band-pass filter
8	TOTAL	Total frequency output (peak hold)

Pin No.	Symbol	Descriptions
9	Vss	Power supply (-6V)
10	R IN	Right channel input
11	L IN	Left channel input : Connecting to ground
12	GND	Ground terminal
13	CLK	Connecting capacitor for clock
14	CLK	Connecting resistor to pin 13 for clock
15	CLK / 2	1/2 clock output
16	Vdd	Power supply (+6V)

■ TC74HC154AP (IC904) : Decoder

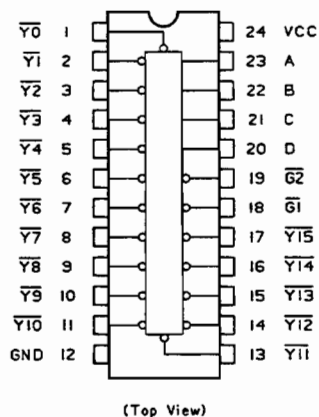

INPUTS						SELECTED OUT P(UT1)
G1	G2	D	C	B	A	
L	L	L	L	L	L	Y0
L	L	L	L	L	H	Y1
L	L	L	L	H	L	Y2
L	L	L	L	H	H	Y3
L	L	L	H	L	L	Y4
L	L	L	H	L	H	Y5
L	L	L	H	H	L	Y6
L	L	L	H	H	H	Y7
L	L	H	L	L	L	Y8
L	L	H	L	L	H	Y9
L	L	H	L	H	L	Y10
L	L	H	L	H	H	Y11
L	L	H	H	L	L	Y12
L	L	H	H	L	H	Y13
L	L	H	H	H	L	Y14
L	L	H	H	H	H	Y15
X	H	X	X	X	X	NONE
H	X	X	X	X	X	NONE

X : Don't care

■ μ PD7001C(IC093)..... A/D Converter

1. Terminal Layout

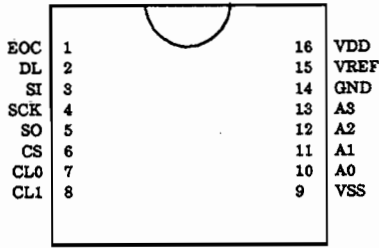

2. Block Diagram

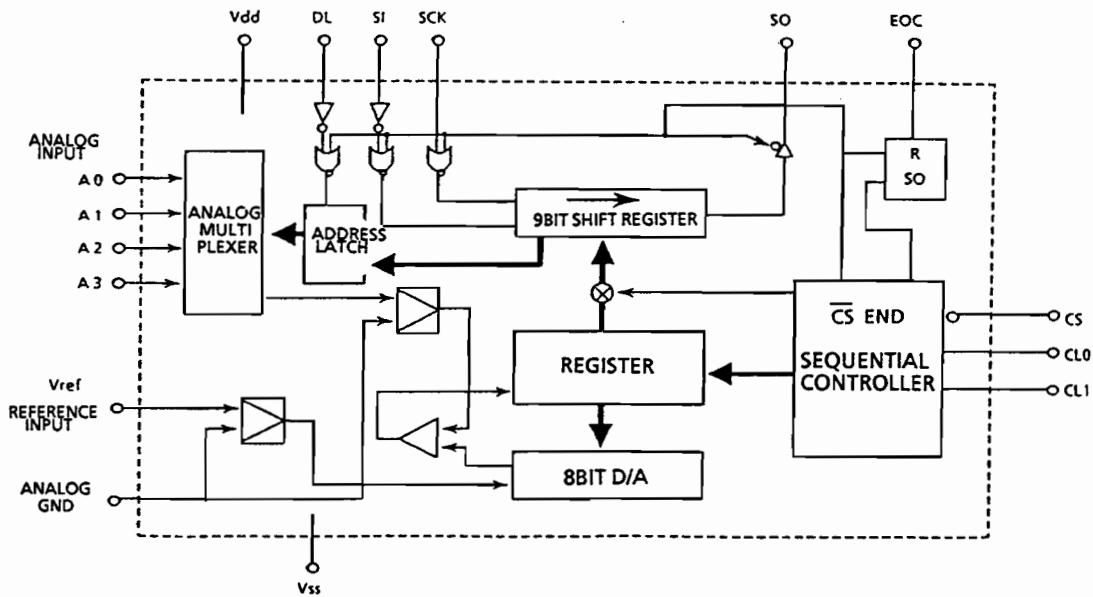

■ TC74HC595AP(IC905)..... 8Bit Shift Register

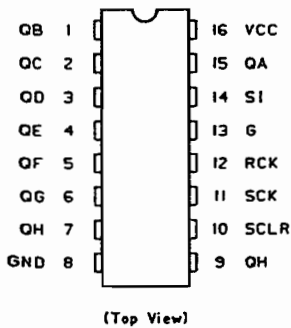

Inputs					Function
B1	SCK	SCLR	RCK	G	
X	X	X	X	H	Output (QA-QH) disable.
X	X	X	X	L	Output (CA-QH) enable.
X	X	L	X	X	Shift register is cleared.
L		H	X	X	Condition of shift register in initial stage is "L". In the other stages, data from the former stage is stored.
H		H	X	X	Condition of shift register in initial stage is "H". In the other stages, data from the former stage is stored.
X		H	X	X	Shift register does not change.
X	X	X		X	Shift register data is stored in the storage register.
X	X	X		X	Storage register does not change.

X: Don't care

Internal Connections for the Display Tube

■ FL901 : ELU0001-106

(1) Grid Division

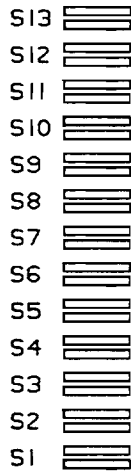
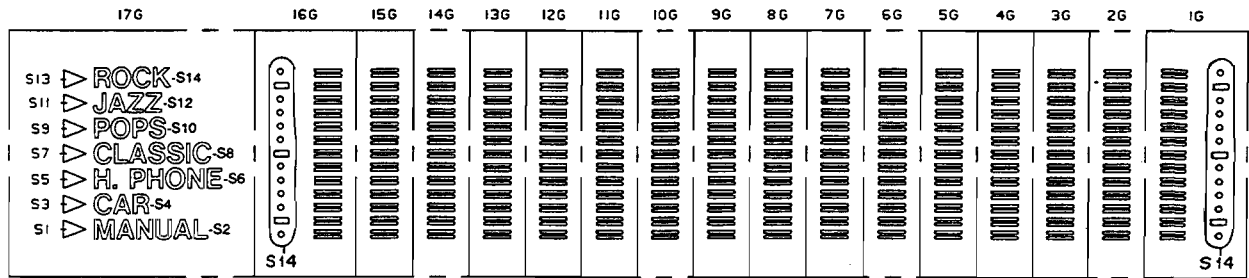

(2) Terminal Connections

PIN CONNECTION

PIN NO.	1	2	3	4	5	6	7	8	9	10	11	12	13	14	15	16	17	18	19	20	21	22	23	24	25	26	27	28	29	30
CONNECTION	F	F	N	N	17	S	S	S	17	S	S	16	16	S	15	S	14	S	13	S	12	S	11	10	S	9	S	8	S	7
	I	I	P	C	G	I	2	3	G	4	5	G	G	6	G	7	G	8	G	9	G	10	G	G	11	G	12	G	13	G

PIN NO.	31	32	33	34	35	36	37	38	39	40	41	42	43	44	45	46
CONNECTION	S	6	5	N	4	N	3	N	2	N	I	N	I	N	F	F
	14	G	G	C	G	C	G	C	G	C	G	C	G	P	2	2

■ Power Primary Section

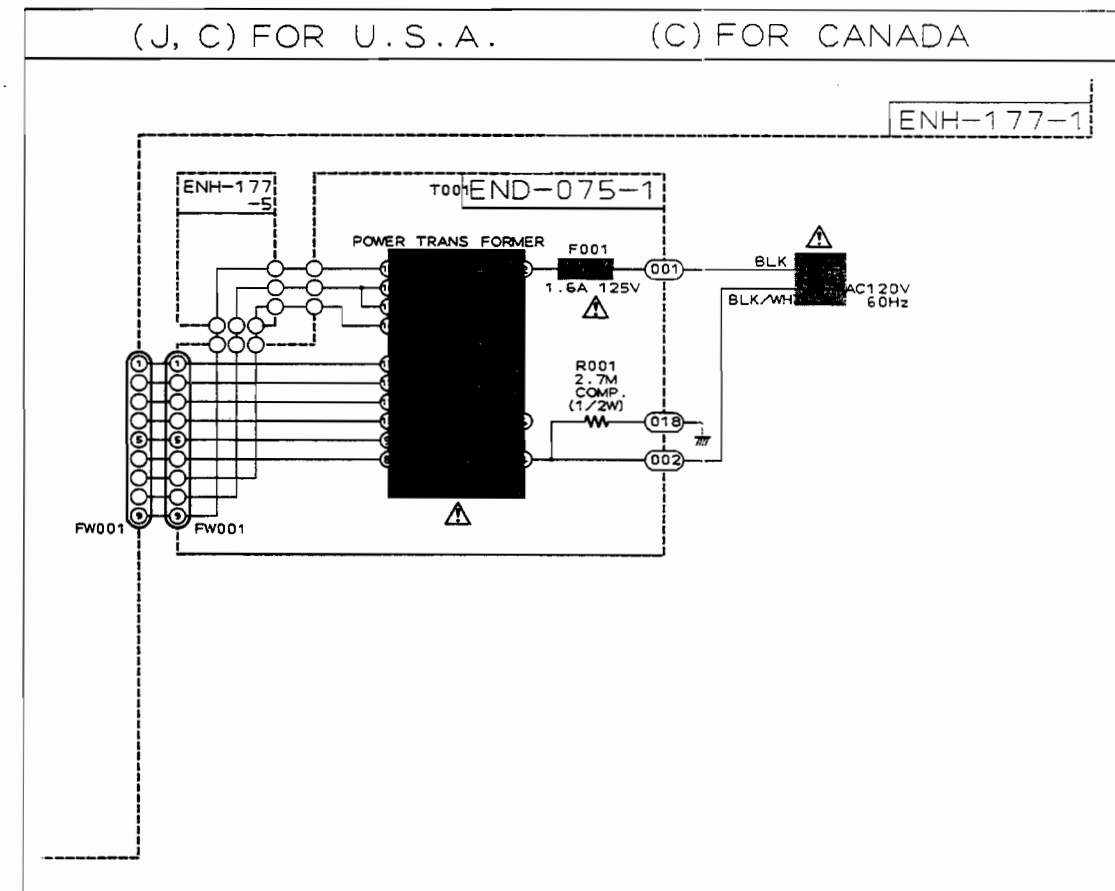
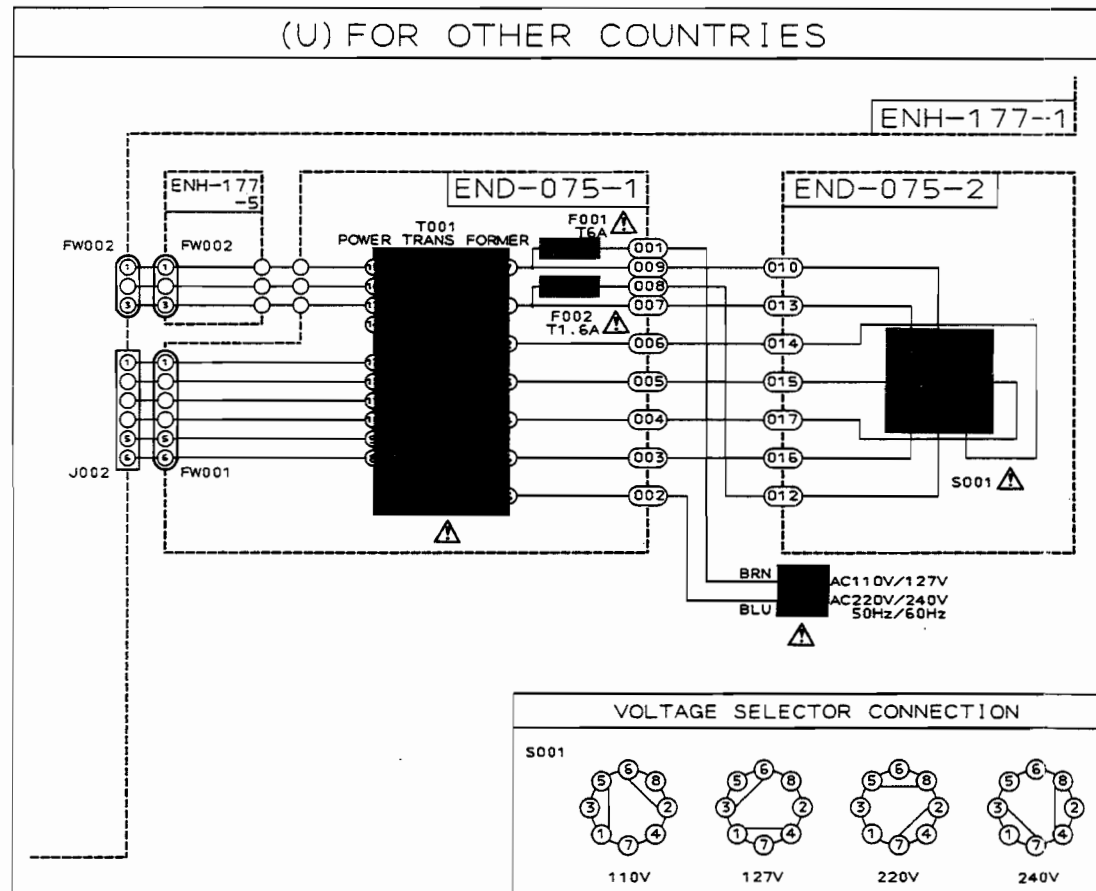
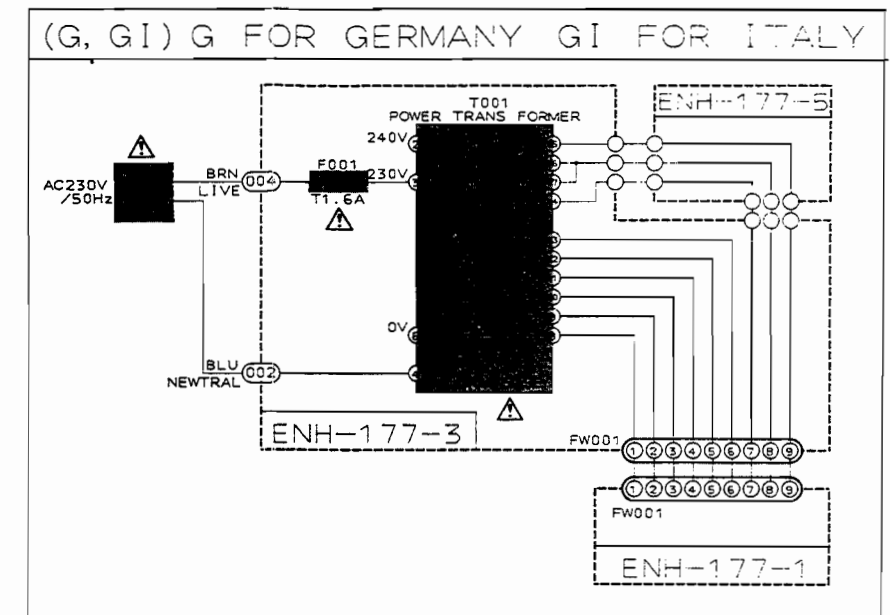
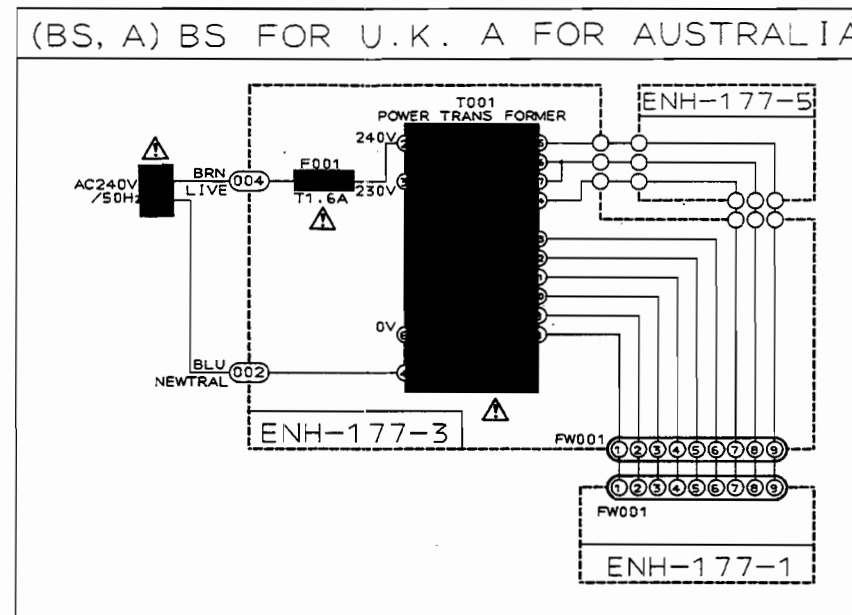
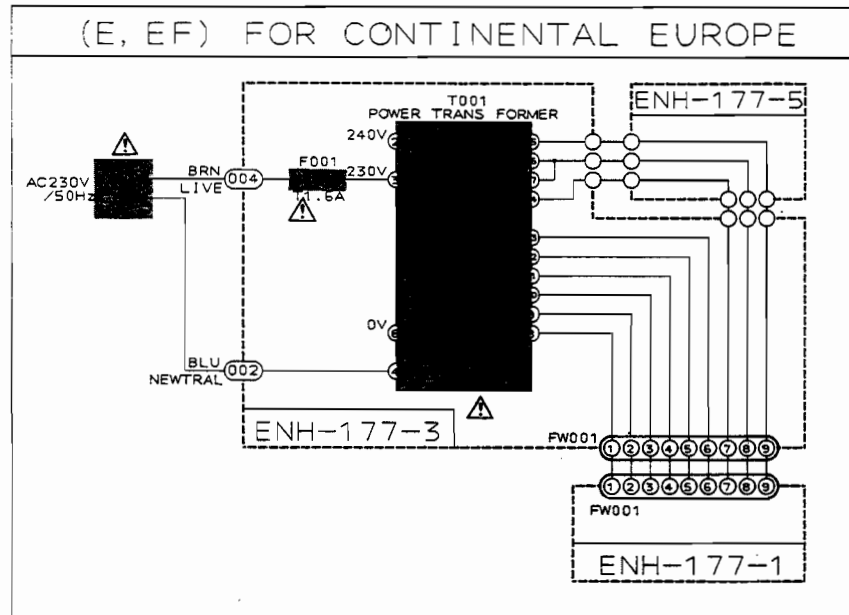

■ Analog Switch & Power Supply PC Board (ENH-177)

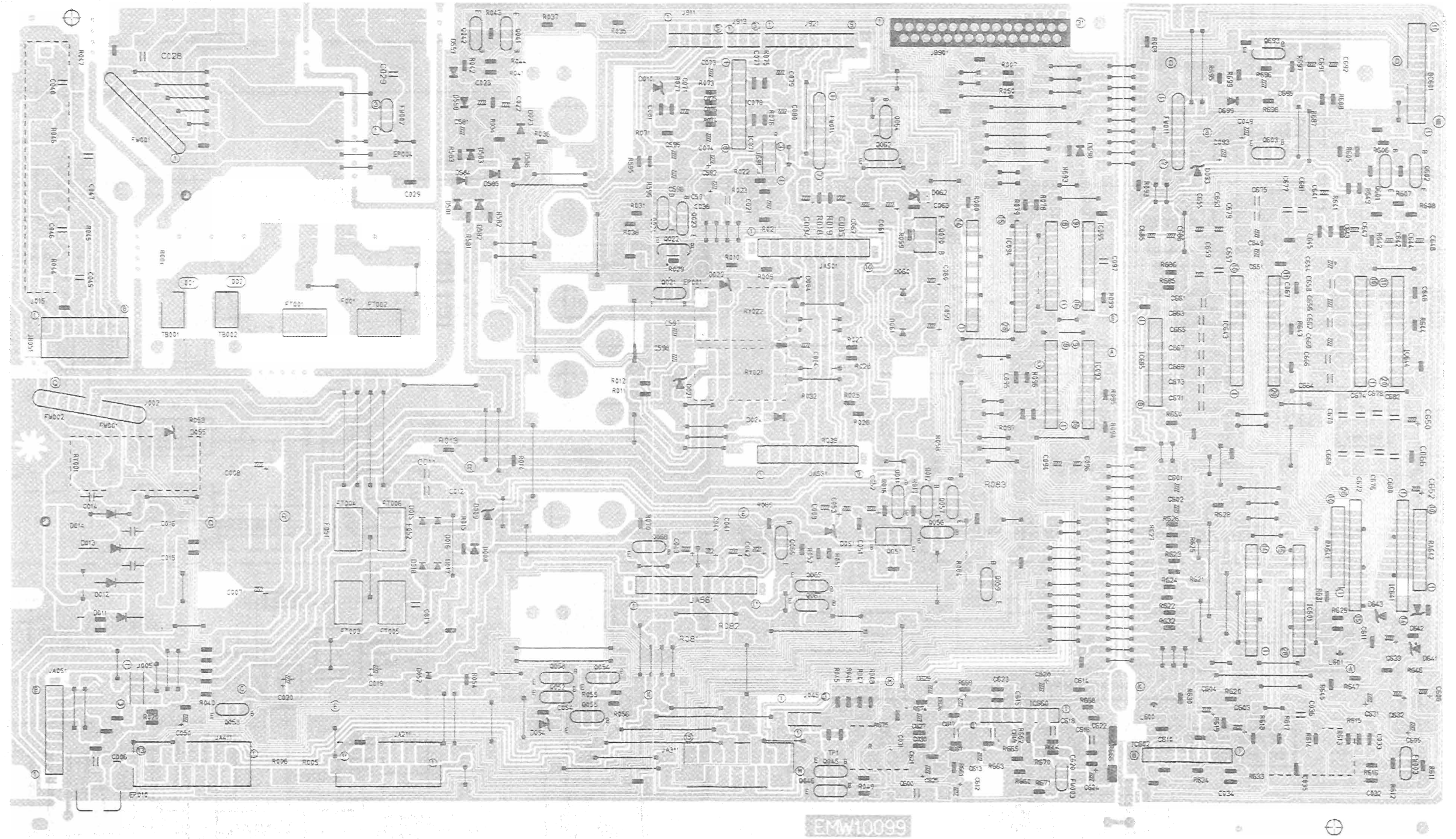

Block Diagram

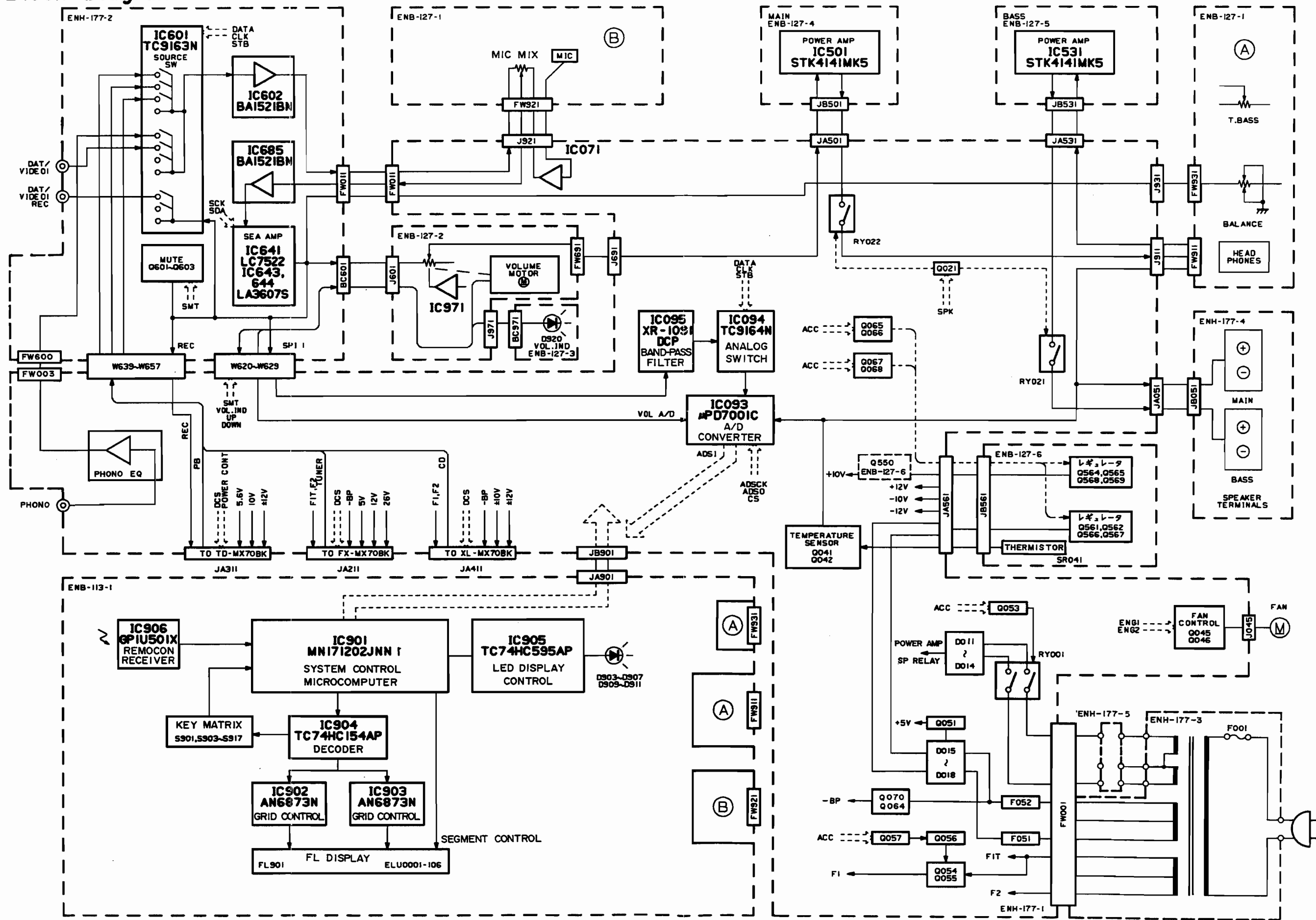

Connection Diagram

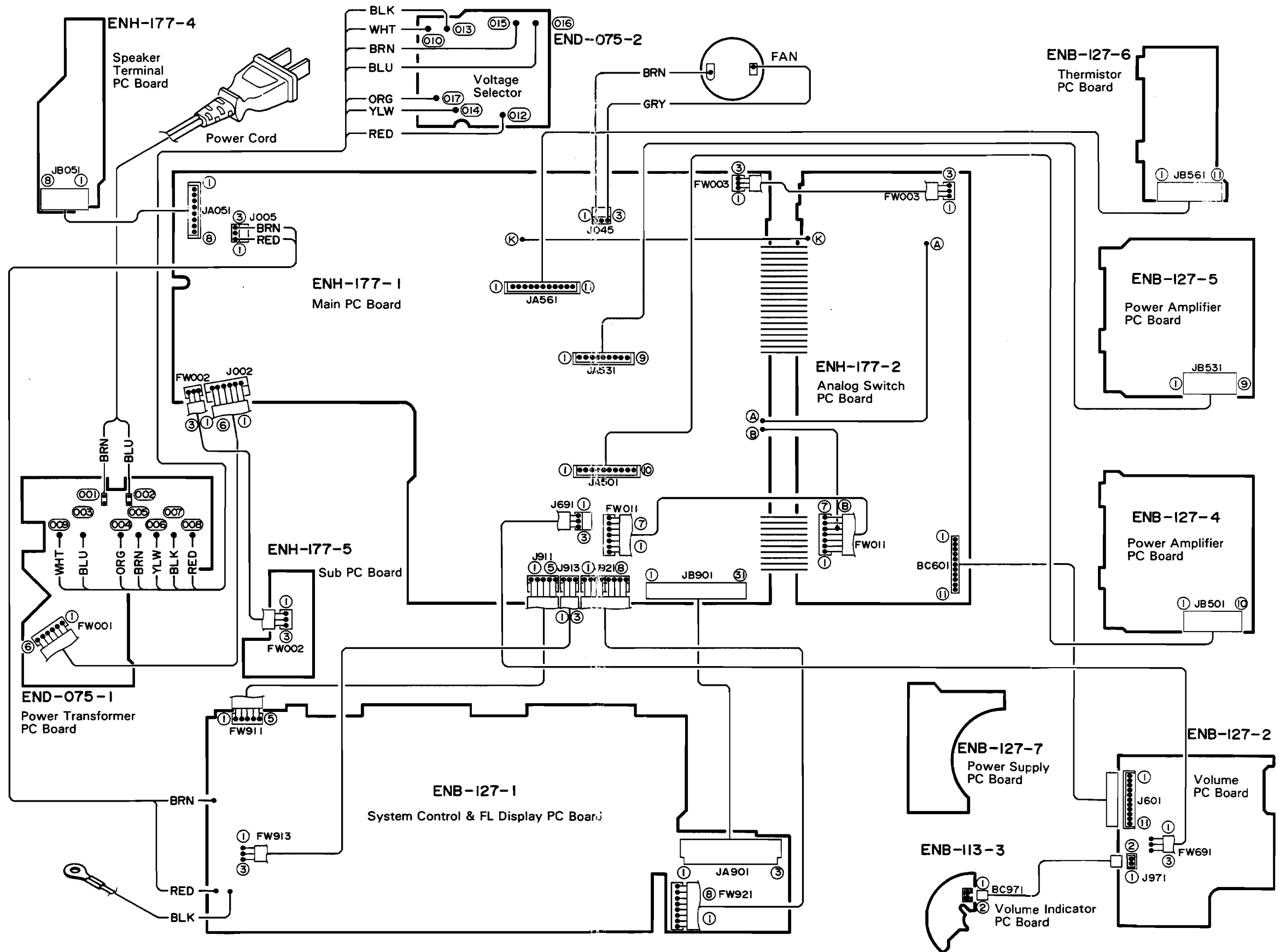

PARTS LIST

Contents

General Exploded View and Parts List	2-2
Printed Circuit Board Ass'y and Parts List	2-5
■ ENH-177 □ Analog Switch & Power Supply PC Board Ass'y	2-5
■ ENB-127 □ System Control & FL Display & Power Amplifier PC Board Ass'y	2-9
■ END-075 A Power Primary PC Board Ass'y	2-12

General Exploded View and Parts List

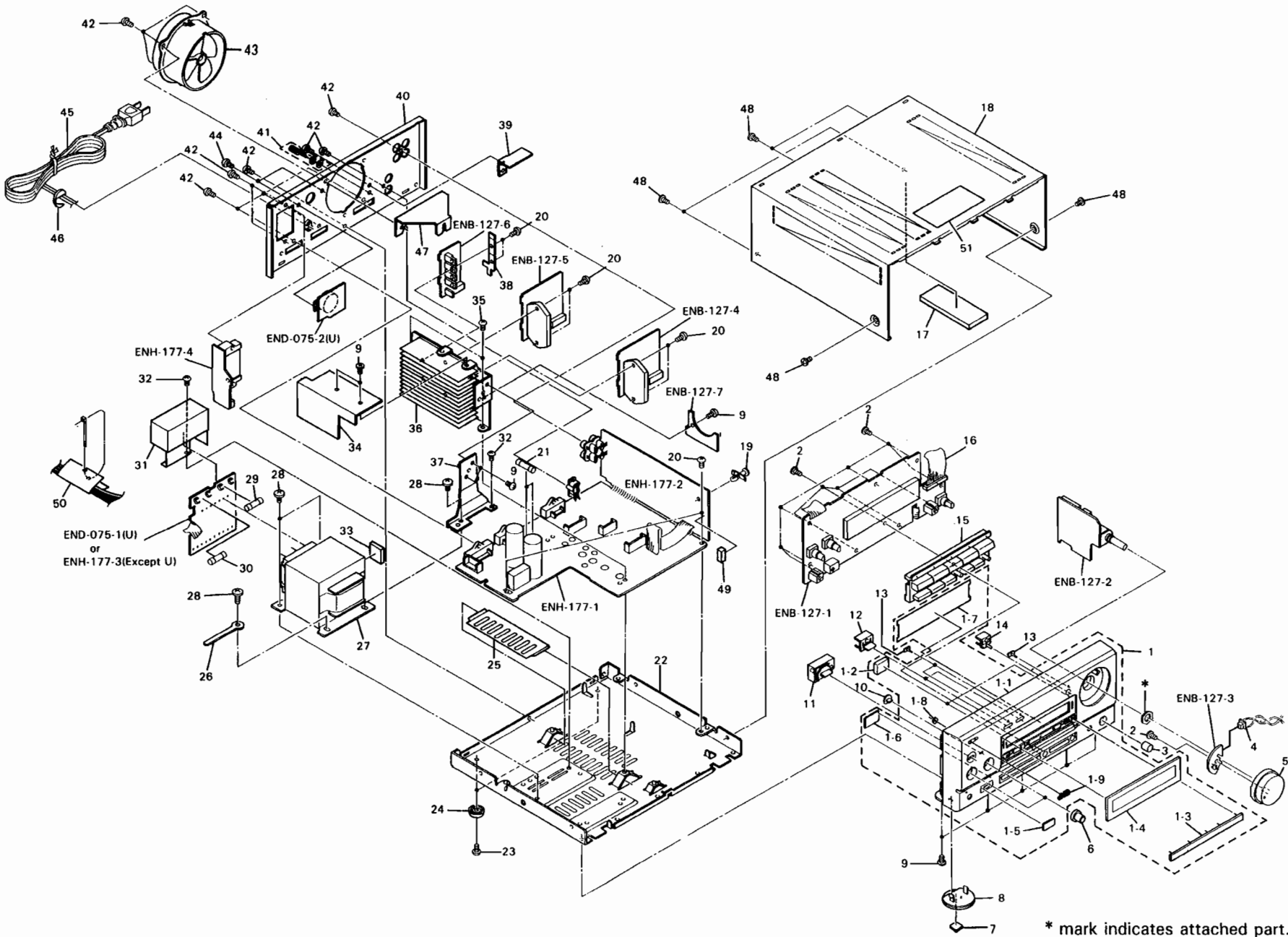

■ Parts List

⚠	Item	Part Number	Part Name	Q'ty	Description	Areas
	1	EFP-AXMX70BKE (S)	Front Panel Ass'y	1		
	1-1	E102322-005	Front Panel	1		
	1-2	E306805-003	Spacer	2		
	1-3	E306922-003	Fitting	1		
	1-4	E306925-002	Window Screen	1		
	1-5	E406093-002	Remote Plate	1		
	1-6	E406259-002	Spacer	1		
	1-7	E406575-001	FL Screen	1		
	1-8	E60912-003	Speed Nut	1		
	1-9	PQ42561	JVC Mark	1		
	2	SDSF2608Z	Screw	11		
	3	E306921-001	Knob	1	MIXING	
	4	EWS142-025	Socket Wire Ass'y	1		
	5	E306918-002	Volume Knob Ass'y	1		
	6	E306920-001	Knob	2	BALANCE BASS	
	7	E75896-001	Spacer	2	for Foot (Front)	
	8	E306935-001	Foot	2	Front	
	9	SDSG3008M	Screw	10		
	10	E406089-001	Indicator	1	STANDBY	
	11	E306914-002	Push Button Ass'y	1	POWER	
	12	E306916-002	Push Button	2	SORROUND	
	13	E406091-001	Indicator	3		
	14	E306917-001	Push Button	1	AI	
	15	E306913-001	Push Button Ass'y	1	SOURCE	
	16	EWR1ZE-11TT	Flat Cable	1		
	17	E306805-024	Spacer	1	for Metal Cover	
	18	E206809-006	Metal Cover	1		
	19	E69384-002	Fastener	1		
	20	SBSG3014Z	Screw	8		
⚠	21	QMF51U1-1R6S	Fuse	2		J, C
⚠		QMF51A2-1R6S	Fuse	2		Except J, C, IS
⚠		QMF51E2-1R6SBS	Fuse	2		BS
	22	E102324-004	Chassis Base	1		
	23	SBSG3010N	Screw	2	for Foot (Rear)	
	24	E47227-029	Foot	2	Rear	
	25	E406638-001	Protect Sheet	1		
	26	E72018-001	Wire Clamp	1		
⚠	27	ETP1050-23JA	Power Transformer	1		J, C
⚠		ETP1050-23FA	Power Transformer	1		U
⚠		ETP1050-23EA	Power Transformer	1		A, E, EF, G, GI
⚠	28	ETP1050-23EABS	Power Transformer	1		BS
⚠	29	E65389-004	Special Screw	4	for Power Transformer	
⚠		QMF51U1-4R0S	Fuse	1		J, C
⚠		QMF51A2-1R6S	Fuse	1		Except J, C, IS
⚠		QMF51E2-1R6SBS	Fuse	1		BS
⚠	30	QMF51A2-4R0S	Fuse	1		U
	31	E307564-001	Primary Cover	1		
	32	SBSG3006M	Screw	2		
	33	E306805-025	Spacer	1		
	34	E307511-001	Heat Sink	1		
	35	SBSG3010CC	Screw	2		
	36	E307506-001	Heat Sink	1		
	37	E406636-001	Heat Sink Bracket	1		
	38	E406237-002	Leaf Spring	1		
	39	E406637-001	Shield Plate	1		
	40	E206807-014	Rear Panel	1		J
		E206807-015	Rear Panel	1		C
		E206807-016	Rear Panel	1		U
		E206807-017	Rear Panel	1		A
		E206807-018	Rear Panel	1		E, EF, G, GI

⚠	Item	Part Number	Part Name	Q'ty	Description	Areas
	41	E206807-019	Rear Panel	1		BS
	42	E70078-003	GND Terminal	1		
	43	SBSG3008M	Screw	13		
	44	E206880-001	Fan Ass'y	1		
	44	SBST3006M	Screw	2	for Voltage Selector	U
⚠	45	QMP1D00-200H	Power Cord	1		J, C
⚠		QMP2560-244	Power Cord	1		A
⚠		QMP3900-200	Power Cord	1		E, EF
⚠		QMP39A0-200	Power Cord	1		G, GI
⚠		QMP7520-200	Power Cord	1		U
⚠	46	QMP9017-008BS	Power Cord	1		BS
⚠		QHS3876-162	Cord Stopper	1		Except BS
⚠		QHS3876-162BS	Cord Stopper	1		BS
	47	E307571-001	Heat Sink Bracket	1		
	48	E75440-001	Special Screw	6	for Metal Cover	
	49	E306805-027	Spacer	1		
	50	E406642-001	Protect Cover	1		Except J, C
	51	E67000-017	Caution Label	1		
	—	E307570-001	Number Label	1		J
	—	E61029-009	Number Label	1		Except J
	—	E76016-004	Caution Label	1		J
	—	E65507-001	Caution Label	1		C
	—	E75803-001	Fuse Caution Label	1		J
	—	QZL1001-001	UL Label	1		J
	—	E45858-002	CSA Label	1		C
	—	E70028-001	Approval Label	1		E
	—	E74792-100	FTZ Label	1		G

The Marks for Designated Areas

⚠ Safety Parts

J.....the U.S.A.	BS.....the U.K.
C.....Canada	GI.....Italy
A.....Australia	U.....Universal Type
E,EF.....Continental Europe	No mark indicates all areas.
G.....Germany	

Note (1)

PC Board Ass'y	Designated Areas
ENH-177 A	the U.S.A.
ENH-177 B	Canada
ENH-177 C	Universal Type
ENH-177 D	Continental Europe
ENH-177 E BS	the U.K.
ENH-177 F	Germany, Italy
ENH-177 G	Australia

Transistors

ITEM	PART NUMBER	DESCRIPTION	AREA
Q011	DTC114YS	SILICON ROHM	
Q012	DTC114YS	SILICON ROHM	
Q021	2SC1685(R,S)	SILICON MATSUSHITA	
Q022	2SC1685(R,S)	SILICON MATSUSHITA	
Q023	2SC1740S(R,S)	SILICON ROHM	
Q024	2SA733A(P,Q)	SILICON NEC	
Q041	2SC1740S(R,S)	SILICON ROHM	
Q042	2SC1740S(R,S)	SILICON ROHM	
Q045	2SD2144S(VW)	SILICON ROHM	
Q046	2SD2144S(VW)	SILICON ROHM	
Q051	2SD1944(J,K)	SILICON ROHM	
Q052	2SC1741A(Q,R)	SILICON ROHM	
Q053	2SC1685(R,S)	SILICON MATSUSHITA	
Q054	2SD1302(S,T)	SILICON MATSUSHITA	
Q055	2SD1302(S,T)	SILICON MATSUSHITA	
Q056	DTA114YS	SILICON ROHM	
Q057	DTC144ES	SILICON ROHM	
Q058	DTC114YS	SILICON ROHM	
Q059	DTC114YS	SILICON ROHM	
Q062	DTA144ES	SILICON ROHM	
Q064	DTC114YS	SILICON ROHM	
Q065	DTC144ES	SILICON ROHM	
Q066	DTA114YS	SILICON ROHM	
Q067	DTA144ES	SILICON ROHM	
Q068	DTC114YS	SILICON ROHM	
Q070	2SB1357(E,F)	SILICON ROHM	
Q601	2SD2144S(VW)	SILICON ROHM	
Q602	2SD2144S(VW)	SILICON ROHM	
Q603	DTA144ES	SILICON ROHM	
Q693	2SC1740S(R,S)	SILICON ROHM	

△ : SAFETY PARTS

I.C.s

ITEM	PART NUMBER	DESCRIPTION	AREA
IC071	BA15218N	I.C. ROHM	
IC093	UPD7001C	I.C. NEC	
IC094	TC9164N	I.C. TOSHIBA	
IC095	XR-1091DCP	I.C. EXAR JAPAN	
IC601	TC9163N	I.C. TOSHIBA	
IC602	BA15218N	I.C. ROHM	
IC641	LC7522	I.C. SANYO	
IC643	LA3607S	I.C. SANYO	
IC644	LA3607S	I.C. SANYO	
IC660	VC4580LD	I.C. DAINICHI	
IC685	BA15218N	I.C. ROHM	

△ : SAFETY PARTS

Diodes

ITEM	PART NUMBER	DESCRIPTION	AREA
D004	MTZ12JC	ZENER ROHM	
D008	1SS133	SILICON ROHM	
D009	MTZ5.1JC	ZENER ROHM	
D010	MTZ5.1JC	ZENER ROHM	
D011	S3V20F	SILICON SINDENGEN	A
D011	S3V20F	SILICON SINDENGEN	B
D011	30DL2FC	SILICON NIHONINTER	C
D011	S3V20F	SILICON SINDENGEN	D
D011	S3V20F	SILICON SINDENGEN	EBS
D011	30DL2FC	SILICON NIHONINTER	F
D011	S3V20F	SILICON SINDENGEN	G
D012	S3V20F	SILICON SINDENGEN	A
D012	S3V20F	SILICON SINDENGEN	B
D012	30DL2FC	SILICON NIHONINTER	C
D012	S3V20F	SILICON SINDENGEN	D

△ : SAFETY PARTS

Diodes

ITEM	PART NUMBER	DESCRIPTION	AREA
D012	S3V20F	SILICON SINDENGEN	EBS
D012	30DL2FC	SILICON NIHONINTER	F
D012	S3V20F	SILICON SINDENGEN	G
D013	S3V20F	SILICON SINDENGEN	A
D013	S3V20F	SILICON SINDENGEN	B
D013	30DL2FC	SILICON NIHONINTER	C
D013	S3V20F	SILICON SINDENGEN	D
D013	S3V20F	SILICON SINDENGEN	EBS
D013	30DL2FC	SILICON NIHONINTER	F
D013	S3V20F	SILICON SINDENGEN	G
D014	S3V20F	SILICON SINDENGEN	A
D014	S3V20F	SILICON SINDENGEN	B
D014	30DL2FC	SILICON NIHONINTER	C
D014	S3V20F	SILICON SINDENGEN	D
D014	S3V20F	SILICON SINDENGEN	EBS
D014	30DL2FC	SILICON NIHONINTER	F
D014	S3V20F	SILICON SINDENGEN	G
D015	1SR139-200	SILICON ROHM	
D016	1SR139-200	SILICON ROHM	
D017	1SR139-200	SILICON ROHM	
D018	1SR139-200	SILICON ROHM	
D021	MTZ12JC	ZENER ROHM	
D022	MTZ12JC	ZENER ROHM	
D023	1SS133	SILICON ROHM	
D024	1SS133	SILICON ROHM	
D051	MTZ6.2JC	ZENER ROHM	
D052	1SR139-200	SILICON ROHM	
D054	MTZ7.5JC	ZENER ROHM	
D055	MTZ12JC	ZENER ROHM	
D060	1SR139-200	SILICON ROHM	
D061	1SR139-200	SILICON ROHM	
D062	MTZ30JC	ZENER ROHM	
D093	MTZ5.1JC	ZENER ROHM	
D557	1SS133	SILICON ROHM	
D558	1SS133	SILICON ROHM	
D581	1SS133	SILICON ROHM	
D582	1SS133	SILICON ROHM	
D583	1SS133	SILICON ROHM	
D584	1SS133	SILICON ROHM	
D585	1SS133	SILICON ROHM	
D586	1SS133	SILICON ROHM	
D641	RD6.8JSB3	ZENER NEC	
D642	RD6.8JSB3	ZENER NEC	
D643	MTZ5.1JC	ZENER ROHM	
D699	1SS133	SILICON ROHM	

△ : SAFETY PARTS

Capacitors

ITEM	PART NUMBER	DESCRIPTION	AREA
C004	QEK51CM-226	22MF 16V ELECTRO	
C006	QCS21HJ-331	330PF 50V CERAMIC	
C007	EEW4205-688T	6800MF ELECTRO	
C008	EEW4205-688T	6800MF ELECTRO	
C009	QEK51HM-225G	2.2MF 50V ELECTRO	
C011	QFLC2AK-103Z	0.01MF 100V MYLAR	
C012	QFLC2AK-103Z	0.01MF 100V MYLAR	
C013	QFLC2AK-103Z	0.01MF 100V MYLAR	
C014	QCE22HP-103	0.01MF 500V CERAMIC	
C015	QCE22HP-103	0.01MF 500V CERAMIC	
C016	QCE22HP-103	0.01MF 500V CERAMIC	
C019	EET3504-228T	2200MF ELECTRO	
C020	EET3504-338T	3300MF ELECTRO	
C021	QETB1HM-474	0.47MF 50V ELECTRO	
C022	QER51CM-226	22MF 16V ELECTRO	
C023	QER60JM-476	47MF 6.3V ELECTRO	
C025	QCY21HK-102	1000PF 50V CERAMIC	
C028	QFN81HK-103	0.01MF 50V MYLAR	
C029	QFN82AK-103	0.01MF 100V MYLAR	
C029	QFN82AK-103	0.01MF 100V MYLAR	
C029	QFN82AK-103	0.01MF 100V MYLAR	
C030	QCB81HK-331	330PF 50V CERAMIC	
C031	QCB81HK-331	330PF 50V CERAMIC	
C032	QCB81HK-331	330PF 50V CERAMIC	
C033	QCB81HK-331	330PF 50V CERAMIC	
C034	QCB81HK-331	330PF 50V CERAMIC	
C035	QCB81HK-331	330PF 50V CERAMIC	
C036	QCF21HP-102	1000PF 50V CERAMIC	
C038	QCS21HJ-331	330PF 50V CERAMIC	
C041	QETB1CM-476	47MF 16V ELECTRO	
C042	QETB1CM-476	47MF 16V ELECTRO	
C043	QETB1CM-476	47MF 16V ELECTRO	
C044	QETB1CM-476	47MF 16V ELECTRO	
C045	QFN81HK-103	0.01MF 50V MYLAR	
C046	QFN81HK-103	0.01MF 50V MYLAR	
C047	QFN81HK-103	0.01MF 50V MYLAR	
C048	QFN81HK-103	0.01MF 50V MYLAR	
C049	QETB1AM-107	100MF 10V ELECTRO	
C050	QETB1HM-106	10MF 50V ELECTRO	
C052	QETB1AM-107	100MF 10V ELECTRO	
C053	QETB1CM-226	22MF 16V ELECTRO	
C054	QCVB1CM-103	0.01MF 16V CERAMIC	
C059	QETB1JM-227	220MF 63V ELECTRO	
C060	QETB1JM-227	220MF 63V ELECTRO	
C061	QETB1HM-226	22MF 50V ELECTRO	

△ : SAFETY PARTS

Capacitors

Δ	ITEM	PART NUMBER	DESCRIPTION			AREA
	C062	QETB1HM-226	22MF	50V	ELECTRO	
	C063	QCGB1HK-102	1000PF	50V	CERAMIC	
	C066	QCBB1HK-101	100PF	50V	CERAMIC	F
	C067	QCBB1HK-101	100PF	50V	CERAMIC	F
	C071	QEK51EM-475G	4.7MF	25V	ELECTRO	
	C073	QEK51CM-106G	10MF	16V	ELECTRO	
	C074	QEK51CM-106G	10MF	16V	ELECTRO	
	C075	QCBB1HK-101	100PF	50V	CERAMIC	
	C076	QCBB1HK-101	100PF	50V	CERAMIC	
	C077	QCGB1HK-102	1000PF	50V	CERAMIC	
	C078	QCGB1HK-102	1000PF	50V	CERAMIC	
	C079	QEK51EM-475G	4.7MF	25V	ELECTRO	
	C080	QEK51EM-475G	4.7MF	25V	ELECTRO	
	C081	QCGB1HK-102	1000PF	50V	CERAMIC	
	C084	QEK51EM-106	10MF	25V	ELECTRO	
	C085	QEK51EM-106	10MF	25V	ELECTRO	
	C086	QCF21HP-473	0.047MF	50V	CERAMIC	
	C087	QCF21HP-473	0.047MF	50V	CERAMIC	
	C090	QETB1HM-475E	4.7MF	50V	ELECTRO	
	C091	QCF21HP-223	0.022MF	50V	CERAMIC	
	C092	QCF21HP-223	0.022MF	50V	CERAMIC	
	C093	QEK51CM-106G	10MF	16V	ELECTRO	
	C094	QEK51CM-106G	10MF	16V	ELECTRO	
	C095	QCSB1HJ-470	47PF	50V	CERAMIC	
	C096	QEK51EM-475G	4.7MF	25V	ELECTRO	
	C097	QFLC1HJ-102Z	1000PF	50V	MYLAR	
	C581	QEK51CM-106G	10MF	16V	ELECTRO	
	C591	EEZ5009-106	10MF		ELECTRO	
	C592	EEZ5009-106	10MF		ELECTRO	
	C595	QEK51HM-474G	0.47MF	50V	ELECTRO	
	C596	QEK51HM-474G	0.47MF	50V	ELECTRO	
	C597	QETB1HM-474	0.47MF	50V	ELECTRO	
	C598	QETB1HM-474	0.47MF	50V	ELECTRO	
	C600	QCC21EM-473	0.047MF	25V	CERAMIC	
	C601	QETB1HM-475	4.7MF	50V	ELECTRO	
	C602	QETB1HM-475	4.7MF	50V	ELECTRO	
	C603	QETB1HM-475	4.7MF	50V	ELECTRO	
	C604	QETB1HM-475	4.7MF	50V	ELECTRO	
	C605	QETB1HM-475	4.7MF	50V	ELECTRO	
	C606	QETB1HM-475	4.7MF	50V	ELECTRO	
	C607	QCC21EM-473	0.047MF	25V	CERAMIC	
	C608	QCC21EM-473	0.047MF	25V	CERAMIC	
	C610	QCBB1HK-101	100PF	50V	CERAMIC	
	C611	QCBB1HK-101	100PF	50V	CERAMIC	
	C612	QETB1HM-475	4.7MF	50V	ELECTRO	
	C613	QETB1HM-475	4.7MF	50V	ELECTRO	
	C614	QCBB1HK-101	100PF	50V	CERAMIC	
	C615	QCBB1HK-101	100PF	50V	CERAMIC	
	C616	QCY21HK-182	1800PF	50V	CERAMIC	
	C617	QCY21HK-182	1800PF	50V	CERAMIC	
	C618	QCY21HK-682	6800PF	50V	CERAMIC	
	C619	QCY21HK-682	6800PF	50V	CERAMIC	
	C620	QCBB1HK-101	100PF	50V	CERAMIC	
	C621	QCBB1HK-101	100PF	50V	CERAMIC	
	C622	QCBB1HK-101	100PF	50V	CERAMIC	
	C623	QCBB1HK-101	100PF	50V	CERAMIC	
	C624	QETB1HM-475	4.7MF	50V	ELECTRO	
	C625	QETB1HM-475	4.7MF	50V	ELECTRO	
	C626	QETB1EM-476	47MF	25V	ELECTRO	
	C627	QETB1EM-476	47MF	25V	ELECTRO	
	C628	QETB1EM-107	100MF	25V	ELECTRO	
	C629	QETB1EM-107	100MF	25V	ELECTRO	
	C631	QETB1CM-226	22MF	16V	ELECTRO	
	C632	QETB1CM-226	22MF	16V	ELECTRO	
	C633	QETB1AM-107	100MF	10V	ELECTRO	
	C641	QEK51EM-475G	4.7MF	25V	ELECTRO	
	C642	QEK51EM-475G	4.7MF	25V	ELECTRO	
	C643	QCSB1HJ-470	47PF	50V	CERAMIC	
	C644	QCSB1HJ-470	47PF	50V	CERAMIC	
	C645	QCBB1HK-101	100PF	50V	CERAMIC	
	C646	QCBB1HK-101	100PF	50V	CERAMIC	
	C647	QEK51EM-475G	4.7MF	25V	ELECTRO	
	C648	QEK51EM-475G	4.7MF	25V	ELECTRO	
	C649	QEK51EM-475G	4.7MF	25V	ELECTRO	
	C650	QEK51EM-475G	4.7MF	25V	ELECTRO	
	C651	QEK51HM-225G	2.2MF	50V	ELECTRO	
	C652	QEK51HM-225G	2.2MF	50V	ELECTRO	
	C653	QEK51HM-474G	0.47MF	50V	ELECTRO	
	C654	QEK51HM-474G	0.47MF	50V	ELECTRO	
	C655	QEK51HM-224G	0.22MF	50V	ELECTRO	
	C656	QEK51HM-224G	0.22MF	50V	ELECTRO	
	C657	QFV81HJ-124	0.12MF	50V	T. FILM	
	C658	QFV81HJ-124	0.12MF	50V	T. FILM	
	C659	QEK51HM-224G	0.22MF	50V	ELECTRO	
	C660	QEK51HM-224G	0.22MF	50V	ELECTRO	
	C661	QFV81HJ-473	0.047MF	50V	T. FILM	
	C662	QFV81HJ-473	0.047MF	50V	T. FILM	
	C663	QFV81HJ-104	0.1MF	50V	T. FILM	
	C664	QFV81HJ-104	0.1MF	50V	T. FILM	
	C665	QFV81HJ-183	0.018MF	50V	T. FILM	
	C666	QFV81HJ-183	0.018MF	50V	T. FILM	
	C667	QFV81HJ-393	0.039MF	50V	T. FILM	
	C668	QFV81HJ-393	0.039MF	50V	T. FILM	
	C669	QFLB1HJ-682	6800PF	50V	MYLAR	
	C670	QFLB1HJ-682	6800PF	50V	MYLAR	
	C671	QFV81HJ-153	0.015MF	50V	T. FILM	
	C672	QFV81HJ-153	0.015MF	50V	T. FILM	
	C673	QFLB1HJ-272	2700PF	50V	MYLAR	

Δ : SAFETY PARTS

Capacitors

Δ	ITEM	PART NUMBER	DESCRIPTION			AREA
	C674	QFLB1HJ-272	2700PF	50V	MYLAR	
	C675	QFLB1HJ-562	5600PF	50V	MYLAR	
	C676	QFLB1HJ-562	5600PF	50V	MYLAR	
	C677	QFLB1HJ-122	1200PF	50V	MYLAR	
	C678	QFLB1HJ-122	1200PF	50V	MYLAR	
	C679	QFLB1HJ-222	2200PF	50V	MYLAR	
	C680	QFLB1HJ-222	2200PF	50V	MYLAR	
	C681	QCS21HJ-471	470PF	50V	CERAMIC	
	C682	QCS21HJ-471	470PF	50V	CERAMIC	
	C685	QEK51EM-475G	4.7MF	25V	ELECTRO	
	C686	QEK51EM-475G	4.7MF	25V	ELECTRO	
	C691	QEK51EM-475G	4.7MF	25V	ELECTRO	
	C692	QEK51EM-475G	4.7MF	25V	ELECTRO	
	C695	QEK51HM-474G	0.47MF	50V	ELECTRO	

Δ : SAFETY PARTS

Resistors

Δ	ITEM	PART NUMBER	DESCRIPTION			AREA
	R001	QRC128K-275EM	2.7M	1/2W	COMPOSITE	A
	R001	QRC128K-275EM	2.7M	1/2W	COMPOSITE	B
	R005	QRX012J-R82A	0.82	1W	M. FILM	
	R006	QRX012J-R82A	0.82	1W	M. FILM	
	R007	QRD167J-102	1K	1/6W	CARBON	
	R008	QRD167J-332	3.3K	1/6W	CARBON	
	R009	QRD167J-102	1K	1/6W	CARBON	
	R010	QRD167J-102	1K	1/6W	CARBON	
	R011	QRD167J-102	1K	1/6W	CARBON	
	R012	QRD167J-102	1K	1/6W	CARBON	
	R015	QRD167J-103	10K	1/6W	CARBON	
	R016	QRD167J-103	10K	1/6W	CARBON	
	R017	QRD167J-102	1K	1/6W	CARBON	
	R018	QRD167J-681	680	1/6W	CARBON	
	R019	QRD167J-681	680	1/6W	CARBON	
	R021	QRD167J-105	1M	1/6W	CARBON	
	R022	QRD167J-473	47K	1/6W	CARBON	
	R023	QRD167J-224	220K	1/6W	CARBON	
	R025	QRD167J-823	82K	1/6W	CARBON	
	R026	QRD167J-104	100K	1/6W	CARBON	
	R027	QRD167J-823	82K	1/6W	CARBON	
	R028	QRD167J-104	100K	1/6W	CARBON	
	R029	QRD167J-473	47K	1/6W	CARBON	
	R031	QRD167J-103	10K	1/6W	CARBON	
	R032	QRG012J-271A	270	1W	O.M. FILM	
	R034	QRD167J-104	100K	1/6W	CARBON	
	R035	QRD167J-222	2.2K	1/6W	CARBON	
	R036	QRD167J-152	1.5K	1/6W	CARBON	
	R037	QRD167J-103	10K	1/6W	CARBON	
	R038	QRD167J-104	100K	1/6W	CARBON	
	R039	QRG012J-122A	1.2K	1W	O.M. FILM	
	R040	QRD167J-223	22K	1/6W	CARBON	
	R041	QRD167J-302	3K	1/6W	CARBON	
	R042	QRD167J-820	82	1/6W	CARBON	
	R043	QRD167J-820	32	1/6W	CARBON	
	R044	QRD167J-751	750	1/6W	CARBON	
	R044	QRD14CJ-100S	10	1/4W	UNF. CARBON	F
	R045	QRD14CJ-100S	10	1/4W	UNF. CARBON	F
	R046	QRD14CJ-100S	10	1/4W	UNF. CARBON	F
	R047	QRD14CJ-100S	10	1/4W	UNF. CARBON	F
	R049	QRD167J-222	2.2K	1/6W	CARBON	
	R050	QRD167J-222	2.2K	1/6W	CARBON	
	R051	QRD167J-103	10K	1/6W	CARBON	
	R052	QRD167J-103	10K	1/6W	CARBON	
	R053	QRG012J-221A	220	1W	O.M. FILM	
	R054	QRD167J-222	2.2K	1/6W	CARBON	
	R055	QRD167J-562	5.6K	1/6W	CARBON	
	R056	QRD167J-562	5.6K	1/6W	CARBON	
	R058	PTH61G25AR4R7M			FUSIBLE	
	R059	QRD167J-332	3.3K	1/6W	CARBON	
	R065	QRD167J-430	43	1/6W	CARBON	
	R066	QRD167J-430	43	1/6W	CARBON	
	R067	QRD167J-240	24	1/6W	CARBON	
	R068	QRD167J-240	24	1/6W	CARBON	
	R069	QRD167J-103	10K	1/6W	CARBON	
	R070	QRD167J-103	10K	1/6W	CARBON	
	R071	QRD167J-103	10K	1/6W	CARBON	
	R073	QRD167J-331	330	1/6W	CARBON	
	R074	QRD167J-331	330	1/6W	CARBON	
	R075	QRD167J-223	22K	1/6W	CARBON	
	R076	QRD167J-223	22K	1/6W	CARBON	
	R077	QRD167J-331	330	1/6W	CARBON	
	R078	QRD167J-102	1K	1/6W	CARBON	
	R079	QRD167J-102	1K	1/6W	CARBON	
	R080	QRD167J-102	1K	1/6W	CARBON	
	R081	QRX012J-R47A	0.47	1W	M. FILM	C
	R081	QRX012J-R47A	0.47	1W	M. FILM	D
	R081	QRX012J-R47A	0.47	1W	M. FILM	EBS
	R081	QRX012J-R47A	0.47	1W	M. FILM	F
	R081	QRX012J-R47A	0.47	1W	M. FILM	G
	R082	QRZ0077-100	10	1/4W	FUSIBLE	
	R086	QRD145J-220S	22	1/4W	UNF. CARBON	A
	R086	QRD145J-220S	22	1/4W	UNF. CARBON	B
	R087	QRD145J-220S	22	1/4W	UNF. CARBON	A
	R087	QRD145J-220S	22	1/4W	UNF. CARBON	B

Δ : SAFETY PARTS

Resistors

Δ	ITEM	PART NUMBER	DESCRIPTION	AREA
	R093	QRD167J-471	470 1/6W CARBON	
	R094	QRD167J-223	22K 1/6W CARBON	
	R095	QRD167J-223	22K 1/6W CARBON	
	R096	QRD167J-273	27K 1/6W CARBON	
	R097	QRD167J-223	22K 1/6W CARBON	
	R099	QRD167J-152	1.5K 1/6W CARBON	
	R581	QRD167J-153	15K 1/6W CARBON	
	R582	QRD167J-153	15K 1/6W CARBON	
	R583	QRD167J-103	10K 1/6W CARBON	
	R595	QRD167J-272	2.7K 1/6W CARBON	
	R596	QRD167J-272	2.7K 1/6W CARBON	
	R605	QRD167J-103	10K 1/6W CARBON	
	R606	QRD167J-103	10K 1/6W CARBON	
	R607	QRD167J-472	4.7K 1/6W CARBON	
	R608	QRD167J-472	4.7K 1/6W CARBON	
	R611	QRD167J-562	5.6K 1/6W CARBON	
	R612	QRD167J-562	5.6K 1/6W CARBON	
	R613	QRD167J-123	12K 1/6W CARBON	
	R614	QRD167J-123	12K 1/6W CARBON	
	R615	QRD167J-683	68K 1/6W CARBON	
	R616	QRD167J-683	68K 1/6W CARBON	
	R617	QRD167J-102	1K 1/6W CARBON	
	R618	QRD167J-102	1K 1/6W CARBON	
	R619	QRD167J-104	100K 1/6W CARBON	
	R620	QRD167J-104	100K 1/6W CARBON	
	R621	QRD167J-102	1K 1/6W CARBON	
	R622	QRD167J-102	1K 1/6W CARBON	
	R623	QRD167J-562	5.6K 1/6W CARBON	
	R624	QRD167J-562	5.6K 1/6W CARBON	
	R625	QRD167J-222	2.2K 1/6W CARBON	
	R626	QRD167J-222	2.2K 1/6W CARBON	
	R627	QRD167J-562	5.6K 1/6W CARBON	
	R628	QRD167J-562	5.6K 1/6W CARBON	
	R629	QRD167J-102	1K 1/6W CARBON	
	R630	QRD167J-102	1K 1/6W CARBON	
	R631	QRD167J-103	10K 1/6W CARBON	
	R632	QRD167J-103	10K 1/6W CARBON	
	R633	QRD167J-104	100K 1/6W CARBON	
	R634	QRD167J-104	100K 1/6W CARBON	
	R641	QRD167J-123	12K 1/6W CARBON	
	R642	QRD167J-123	12K 1/6W CARBON	
	R643	QRD167J-113	11K 1/6W CARBON	
	R644	QRD167J-113	11K 1/6W CARBON	
	R645	QRD167J-271	270 1/6W CARBON	
	R646	QRD167J-271	270 1/6W CARBON	
	R647	QRD167J-431	430 1/6W CARBON	
	R649	QRD167J-223	22K 1/6W CARBON	
	R650	QRD167J-223	22K 1/6W CARBON	
	R660	QRD167J-222	2.2K 1/6W CARBON	
	R661	QRD167J-222	2.2K 1/6W CARBON	
	R662	QRD167J-473	47K 1/6W CARBON	
	R663	QRD167J-473	47K 1/6W CARBON	
	R664	QRD167J-474	470K 1/6W CARBON	
	R665	QRD167J-474	470K 1/6W CARBON	
	R666	QRD167J-393	39K 1/6W CARBON	
	R667	QRD167J-393	39K 1/6W CARBON	
	R668	QRD167J-561	560 1/6W CARBON	
	R669	QRD167J-561	560 1/6W CARBON	
	R670	QRD167J-122	1.2K 1/6W CARBON	
	R671	QRD167J-122	1.2K 1/6W CARBON	
	R674	QRD167J-681	680 1/6W CARBON	
	R675	QRD167J-681	680 1/6W CARBON	
	R685	QRD167J-104	100K 1/6W CARBON	
	R686	QRD167J-104	100K 1/6W CARBON	
	R687	QRD167J-224	220K 1/6W CARBON	
	R688	QRD167J-224	220K 1/6W CARBON	
	R695	QRD167J-562	5.6K 1/6W CARBON	
	R696	QRD167J-104	100K 1/6W CARBON	
	R697	QRD167J-103	10K 1/6W CARBON	
	R698	QRD167J-104	100K 1/6W CARBON	
	R699	QRD167J-473	47K 1/6W CARBON	
	RA641	QRB099J-474	470K 1/10W R.NETWORK	
	RA642	QRB099J-474	470K 1/10W R.NETWORK	

Δ : SAFETY PARTS

Others

Δ	ITEM	PART NUMBER	DESCRIPTION	AREA
		E3400-431	SPACER	
		E70306-005	HEAT SINK	
		SBSG30082	SCREW	
		EMW10099-002	CIRCUIT BOARD	A
		E61380-010	FUSE LABEL	A
		E61380-032	FUSE LABEL	A
		EMW10099-002	CIRCUIT BOARD	B
		E61380-010	FUSE LABEL	B
		E61380-032	FUSE LABEL	B
		EMW10099-002	CIRCUIT BOARD	C
		EMW10099-002	CIRCUIT BOARD	D
		EMW10099-002BS	CIRCUIT BOARD	EBS
		EMW10099-002	CIRCUIT BOARD	F
		EMW10099-002	CIRCUIT BOARD	G
	J002	VMC0107-006	CONNECT TERMINAL (6PIN)	C
	J005	EMV7122-103	CONNECTOR (2PIN)	
	J015	EMB90TV-803A	SPEAKER TERMINAL	
	J045	EMV7122-103	CONNECTOR (2PIN)	
	J085	EMN00TV-215A	2P PIN JACK	
	J601	EMN00TV-405A	4P PIN JACK	
	L600	EQL2106-223	INDUCTOR	
	L601	EQL2106-223	INDUCTOR	
	BC601	EWS25B-A057	SOCKET WIRE (11PIN)	
	EP001	EWT011-092	TERMINAL WIRE	F
	EP002	E70859-001	EARTH PLATE	
	EP010	E70225-001	EARTH PLATE	
	FT001	EMG7331-002	FUSE CLIP	A
	FT001	EMG7331-002	FUSE CLIP	B
	FT001	EMG7331-002	FUSE CLIP	D
	FT001	EMG7331-002	FUSE CLIP	EBS
	FT001	EMG7331-002	FUSE CLIP	F
	FT001	EMG7331-002	FUSE CLIP	G
	FT002	EMG7331-002U	FUSE CLIP	A
	FT002	EMG7331-002U	FUSE CLIP	B
	FT002	EMG7331-002U	FUSE CLIP	D
	FT002	EMG7331-002U	FUSE CLIP	EBS
	FT002	EMG7331-002U	FUSE CLIP	F
	FT002	EMG7331-002U	FUSE CLIP	G
	FT003	EMG7331-002	FUSE CLIP	
	FT004	EMG7331-002U	FUSE CLIP	
	FT005	EMG7331-002	FUSE CLIP	
	FT006	EMG7331-002U	FUSE CLIP	
	FW001	EWR3AB-16SS	FLAT WIRE (10PIN)	A
	FW001	EWR3AB-16SS	FLAT WIRE (10PIN)	B
	FW001	EWR3AB-16SS	FLAT WIRE (10PIN)	D
	FW001	EWR3AB-16SS	FLAT WIRE (10PIN)	EBS
	FW001	EWR3AB-16SS	FLAT WIRE (10PIN)	F
	FW002	EWR33B-20SS	FLAT WIRE (3PIN)	G
	FW003	EWR33B-16SS	FLAT WIRE (3PIN)	
	FW011	EWR37B-16SS	FLAT WIRE (7PIN)	
	JA051	EMV5125-008	PLUG ASSY (8PIN)	
	JA211	EMV7127-011	CONNECTOR (11PIN)	
	JA311	EMV7127-015	CONNECTOR (15PIN)	
	JA411	EMV7127-013	CONNECTOR (13PIN)	
	JA501	EMV5125-010	PLUG ASSY (10PIN)	
	JA531	EMV5125-009	PLUG ASSY (9PIN)	
	JA561	EMV5125-011	PLUG ASSY (11PIN)	
	JB051	EMV7125-008R	CONNECTOR (8PIN)	
	JB901	EMV7123-031	CONNECTOR (31PIN)	
	JT691	EMV7122-103	CONNECTOR (3PIN)	
	JT911	EMV7122-005	CONNECTOR (5PIN)	
	JT913	EMV7122-103	CONNECTOR (3PIN)	
	JT921	EMV7122-004	CONNECTOR (4PIN)	
	JT922	EMV7122-004	CONNECTOR (4PIN)	
	RY001	ESK1012-211M	RELAY	
	RY021	ESK8012-211M	RELAY	
	RY022	ESK8012-211M	RELAY	
	TB001	E65508-002	TAB	A
	TB001	E65508-002	TAB	B
	TB001	E65508-002	TAB	D
	TB001	E65508-002	TAB	EBS
	TB001	E65508-002	TAB	F
	TB001	E65508-002	TAB	G
	TB002	E65508-002	TAB	A
	TB002	E65508-002	TAB	B
	TB002	E65508-002	TAB	D
	TB002	E65508-002	TAB	EBS
	TB002	E65508-002	TAB	F
	TB002	E65508-002	TAB	G

Δ : SAFETY PARTS

■ENB-127 □ System Control & FL Display & Power Amplifier PC Board Ass'y

Note : ENB-127 □ varies according to the areas employed. See note (1) when placing an order.

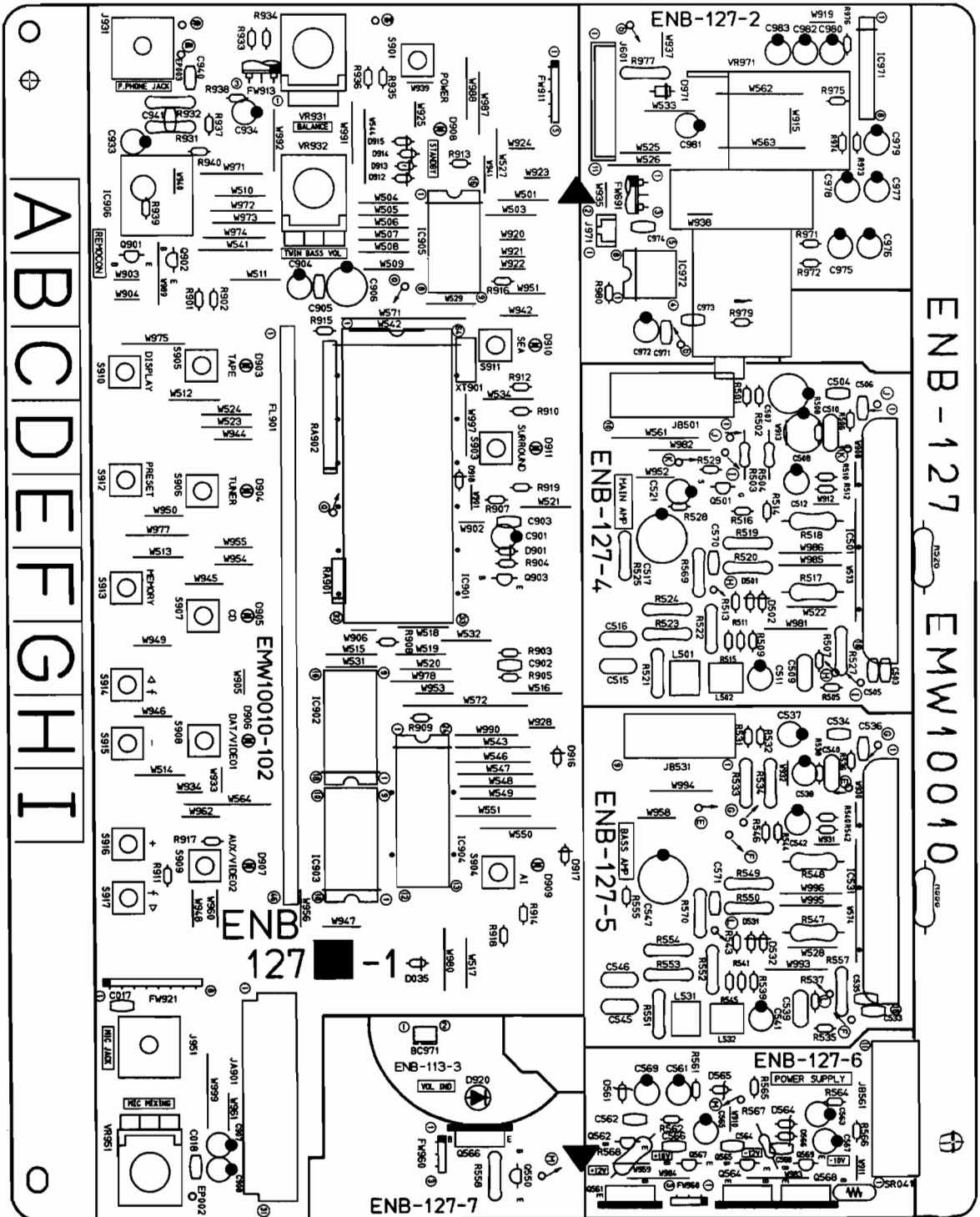

Note (1)

PC Board Ass'y	Designated Areas
ENB-127 A	the U.S.A., Canada
ENB-127 B	Australia, the U.K. Continental Europe Universal Type
ENB-127 C	Germany, Italy

Transistors

Δ	ITEM	PART NUMBER	DESCRIPTION		AREA
	Q501	2SK301(P,Q)	F.E.T	MATSUSHITA	A
	Q550	2SC1685(R,S)	SILICON	MATSUSHITA	
	Q561	2SD2061(E,F)	SILICON	ROHM	
	Q562	2SC1685(R,S)	SILICON	MATSUSHITA	
	Q563	2SC1685(R,S)	SILICON	MATSUSHITA	
	Q564	2SB1187(E,F)	SILICON	ROHM	
	Q565	2SA564A(R,S)	SILICON	MATSUSHITA	
	Q566	2SD2061(E,F)	SILICON	ROHM	
	Q567	2SC1685(R,S)	SILICON	MATSUSHITA	
	Q568	2SB1187(E,F)	SILICON	ROHM	
	Q569	2SA564A(R,S)	SILICON	MATSUSHITA	
	Q901	DTC1132S	SILICON	ROHM	A
	Q902	DTA144ES	SILICON	ROHM	
	Q903	DTC114YS	SILICON	ROHM	

Δ : SAFETY PARTS

I.C.s

Δ	ITEM	PART NUMBER	DESCRIPTION		AREA
	IC501	STK4141MK5	I.C.	SANYO	A
	IC531	STK4141MK5	I.C.	SANYO	
	IC901	MN17120JNY	I.C.	MATSUSHITA	
	IC902	AN6873N	I.C.	MATSUSHITA	
	IC903	AN6873N	I.C.	MATSUSHITA	
	IC904	TC74HC154AP	I.C.	TOSHIBA	
	IC905	TC74HC595AP	I.C.	TOSHIBA	
	IC906	GP1U501X	I.C.	SHARP	
	IC971	BA15218N	I.C.	ROHM	
	IC972	LB1639-CV	I.C.	SANYO	

Δ : SAFETY PARTS

Diodes

Δ	ITEM	PART NUMBER	DESCRIPTION		AREA
	D035	1SS133	SILICON	ROHM	A
	D501	1SS133	SILICON	ROHM	
	D502	1SS133	SILICON	ROHM	
	D531	1SS133	SILICON	ROHM	
	D532	1SS133	SILICON	ROHM	
	D561	RD13JSB3	ZENER	NEC	
	D564	RD13JSB3	ZENER	NEC	
	D565	MTZ111JC	ZENER	ROHM	
	D566	MTZ111JC	ZENER	ROHM	
	D900	MTZ5.6JC	ZENER	ROHM	
	D901	1SS133	SILICON	ROHM	
	D903	SLH-34VC3F	L.E.D.	ROHM	
	D904	SLH-34VC3F	L.E.D.	ROHM	
	D905	SLH-34VC3F	L.E.D.	ROHM	
	D906	SLH-34VC3F	L.E.D.	ROHM	
	D907	SLH-34VC3F	L.E.D.	ROHM	
	D908	SLH-34VC3F	L.E.D.	ROHM	
	D909	SLH-34VC3F	L.E.D.	ROHM	
	D910	SLH-34DC3F	L.E.D.	ROHM	
	D911	SLH-34DC3F	L.E.D.	ROHM	
	D912	1SS133	SILICON	ROHM	
	D913	1SS133	SILICON	ROHM	
	D914	1SS133	SILICON	ROHM	
	D915	1SS133	SILICON	ROHM	
	D916	1SS133	SILICON	ROHM	
	D917	1SS133	SILICON	ROHM	
	D918	1SS133	SILICON	ROHM	
	D920	LN282RPX	L.E.D.		
	D971	1SR139-200	SILICON	ROHM	

Δ : SAFETY PARTS

Capacitors

Δ	ITEM	PART NUMBER	DESCRIPTION			AREA
	C017	QCC21EM-473	0.047MF	25V	CERAMIC	C
	C503	QCBB1HK-101	100PF	50V	CERAMIC	
	C504	QCBB1HK-101	100PF	50V	CERAMIC	
	C505	QCBB1HK-101	100PF	50V	CERAMIC	
	C506	QCBB1HK-101	100PF	50V	CERAMIC	
	C507	EEZ2505-107	100MF		ELECTRO	
	C508	EEZ2505-107	100MF		ELECTRO	
	C509	QCS21HJ-5R0	5PF	50V	CERAMIC	
	C510	QCS21HJ-5R0	5PF	50V	CERAMIC	
	C511	QETB1HM-226	22MF	50V	ELECTRO	
	C512	QETB1HM-226	22MF	50V	ELECTRO	
	C515	QFLB1HK-473	0.047MF	50V	MYLAR	
	C516	QFLB1HK-473	0.047MF	50V	MYLAR	
	C517	QETB2AM-476	47MF	100V	ELECTRO	
	C521	QEK51HM-224G	0.22MF	50V	ELECTRO	
	C533	QCBB1HK-101	100PF	50V	CERAMIC	
	C534	QCBB1HK-101	100PF	50V	CERAMIC	
	C535	QCXB1CM-392	3900PF	16V	CERAMIC	
	C536	QCXB1CM-392	3900PF	16V	CERAMIC	
	C537	QETB1HM-225	2.2MF	50V	ELECTRO	
	C538	QETB1HM-225	2.2MF	50V	ELECTRO	
	C539	QFLB1HK-333	0.033MF	50V	MYLAR	
	C540	QFLB1HK-333	0.033MF	50V	MYLAR	
	C541	QETB1HM-226	22MF	50V	ELECTRO	
	C542	QETB1HM-226	22MF	50V	ELECTRO	
	C545	QFLB1HK-473	0.047MF	50V	MYLAR	
	C546	QFLB1HK-473	0.047MF	50V	MYLAR	
	C547	QETB2AM-476	47MF	100V	ELECTRO	
	C561	QETB1EM-226	22MF	25V	ELECTRO	
	C562	QCGB1HK-102	1000PF	50V	CERAMIC	
	C563	QETB1CM-226	22MF	16V	ELECTRO	
	C564	QCGB1HK-102	1000PF	50V	CERAMIC	
	C565	QETB1CM-226	22MF	16V	ELECTRO	
	C566	QCGB1HK-102	1000PF	50V	CERAMIC	
	C567	QETB1CM-226	22MF	16V	ELECTRO	
	C568	QCGB1HK-102	1000PF	50V	CERAMIC	
	C569	QETB1CM-476	47MF	16V	ELECTRO	
	C570	QCBB1HK-681	680PF	50V	CERAMIC	
	C571	QCBB1HK-681	680PF	50V	CERAMIC	
	C901	QETB1HM-225	2.2MF	50V	ELECTRO	
	C902	QCVB1CM-103	0.01MF	16V	CERAMIC	
	C903	QCVB1CM-103	0.01MF	16V	CERAMIC	
	C904	QETB1AM-107	100MF	10V	ELECTRO	
	C905	QCHB1EZ-223	0.022MF	25V	CERAMIC	
	C906	QETB1AM-477	470MF	10V	ELECTRO	
	C907	QEK51HM-225G	2.2MF	50V	ELECTRO	
	C908	QEK51HM-225G	2.2MF	50V	ELECTRO	
	C933	QER51HM-105G	1MF	50V	ELECTRO	
	C934	QER51HM-105G	1MF	50V	ELECTRO	
	C940	QCBB1HK-221	220PF	50V	CERAMIC	
	C941	QCBB1HK-221	220PF	50V	CERAMIC	
	C971	QCVB1CM-103	0.01MF	16V	CERAMIC	
	C972	QETB1CM-226	22MF	16V	ELECTRO	
	C973	QCHB1EZ-223	0.022MF	25V	CERAMIC	
	C974	QCVB1CM-103	0.01MF	16V	CERAMIC	
	C975	QETB1AM-476	47MF	10V	ELECTRO	
	C976	QETB1AM-476	47MF	10V	ELECTRO	
	C977	QETB1HM-105	1MF	50V	ELECTRO	
	C978	QETB1HM-105	1MF	50V	ELECTRO	
	C979	QETB1HM-225	2.2MF	50V	ELECTRO	
	C980	QETB1HM-225	2.2MF	50V	ELECTRO	
	C981	QETB1AM-476	47MF	10V	ELECTRO	
	C982	QETB1EM-106	10MF	25V	ELECTRO	
	C983	QETB1EM-106	10MF	25V	ELECTRO	

Δ : SAFETY PARTS

Resistors

Δ	ITEM	PART NUMBER	DESCRIPTION			AREA
	R501	QRD167J-104	100K	1/6W	CARBON	A
	R502	QRD167J-104	100K	1/6W	CARBON	
	R503	ERD141J-561S	560	1/4W	CARBON	
	R504	ERD141J-561S	560	1/4W	CARBON	
	R505	QRD167J-471	470	1/6W	CARBON	
	R506	QRD167J-471	470	1/6W	CARBON	
	R507	QRD167J-104	100K	1/6W	CARBON	
	R508	QRD167J-104	100K	1/6W	CARBON	
	R509	QRD167J-562	5.6K	1/6W	CARBON	
	R510	QRD167J-562	5.6K	1/6W	CARBON	
	R511	QRD167J-562	5.6K	1/6W	CARBON	
	R512	QRD167J-562	5.6K	1/6W	CARBON	
	R513	QRD167J-562	5.6K	1/6W	CARBON	
	R514	QRD167J-562	5.6K	1/6W	CARBON	
	R515	QRD167J-562	5.6K	1/6W	CARBON	
	R516	QRD167J-562	5.6K	1/6W	CARBON	
	R517	QRX012J-R22AM	0.22	1W	M.FILM	
	R518	QRX012J-R22AM	0.22	1W	M.FILM	
	R519	QRZ0077-101	100	1/4W	FUSIBLE	
	R520	QRZ0077-100	10	1/4W	FUSIBLE	
	R521	QRD14CJ-100S	10	1/4W	UNF. CARBON	
	R522	QRD14CJ-100S	10	1/4W	UNF. CARBON	
	R523	QRD14CJ-100S	10	1/4W	UNF. CARBON	
	R524	QRD14CJ-100S	10	1/4W	UNF. CARBON	
	R525	QRD14CJ-222S	2.2K	1/4W	UNF. CARBON	

Δ : SAFETY PARTS

Resistors

Δ	ITEM	PART NUMBER	DESCRIPTION		AREA	
Δ	R526	QRG022J-102AM	1K	2W	O.M.FILM	
Δ	R527	QRD14CJ-100S	10	1/4W	UNF. CARBON	
	R528	QRD167J-112	1.1K	1/6W	CARBON	
	R529	QRD167J-105	1M	1/6W	CARBON	
	R531	QRD167J-104	100K	1/6W	CARBON	
	R532	QRD167J-104	100K	1/6W	CARBON	
Δ	R533	QRD14CJ-681S	680	1/4W	UNF. CARBON	
Δ	R534	QRD14CJ-681S	680	1/4W	UNF. CARBON	
	R535	QRD167J-473	47K	1/6W	CARBON	
	R536	QRD167J-473	47K	1/6W	CARBON	
	R537	QRD167J-473	47K	1/6W	CARBON	
	R538	QRD167J-473	47K	1/6W	CARBON	
	R539	QRD167J-562	5.6K	1/6W	CARBON	
	R540	QRD167J-562	5.6K	1/6W	CARBON	
	R541	QRD167J-562	5.6K	1/6W	CARBON	
	R542	QRD167J-562	5.6K	1/6W	CARBON	
	R543	QRD167J-562	5.6K	1/6W	CARBON	
	R544	QRD167J-562	5.6K	1/6W	CARBON	
	R545	QRD167J-562	5.6K	1/6W	CARBON	
	R546	QRD167J-562	5.6K	1/6W	CARBON	
Δ	R547	QRX012J-R22AM	0.22	1W	M.FILM	
Δ	R548	QRX012J-R22AM	0.22	1W	M.FILM	
Δ	R549	QRZ0077-101	100	1/4W	FUSIBLE	
Δ	R550	QRZ0077-100	10	1/4W	FUSIBLE	
Δ	R551	QRD14CJ-100S	10	1/4W	UNF. CARBON	
Δ	R552	QRD14CJ-100S	10	1/4W	UNF. CARBON	
Δ	R553	QRD14CJ-100S	10	1/4W	UNF. CARBON	
Δ	R554	QRD14CJ-100S	10	1/4W	UNF. CARBON	
Δ	R555	QRD167J-103	10K	1/6W	CARBON	
Δ	R556	QRG022J-102AM	1K	2W	O.M.FILM	
Δ	R557	QRD14CJ-100S	10	1/4W	UNF. CARBON	
Δ	R558	QRX012J-R47A	0.47	1W	M.FILM	A
	R561	QRD167J-152	1.5K	1/6W	CARBON	
	R562	QRD167J-471	470	1/6W	CARBON	
	R564	QRD167J-222	2.2K	1/6W	CARBON	
	R565	QRD167J-332	3.3K	1/6W	CARBON	
	R566	QRD167J-332	3.3K	1/6W	CARBON	
	R567	QRZ0077-4R7	4.7	1/4W	FUSIBLE	
Δ	R568	QRX012J-R68AM	0.68	1W	M.FILM	
Δ	R569	QRD14CJ-101S	100	1/4W	UNF. CARBON	
Δ	R570	QRD14CJ-101S	100	1/4W	UNF. CARBON	
Δ	R901	QRD167J-472	4.7K	1/6W	CARBON	
	R902	QRD167J-472	4.7K	1/6W	CARBON	
	R903	QRD167J-472	4.7K	1/6W	CARBON	
	R904	QRD167J-104	100K	1/6W	CARBON	
	R905	QRD167J-103	10K	1/6W	CARBON	
	R907	QRD167J-473	47K	1/6W	CARBON	
	R908	QRD167J-223	22K	1/6W	CARBON	
	R909	QRD167J-472	4.7K	1/6W	CARBON	
	R910	QRD167J-331	330	1/6W	CARBON	
	R911	QRD167J-331	330	1/6W	CARBON	
	R912	QRD167J-331	330	1/6W	CARBON	
	R913	QRD167J-331	330	1/6W	CARBON	
	R914	QRD167J-331	330	1/6W	CARBON	
	R915	QRD167J-101	100	1/6W	CARBON	
	R916	QRD167J-103	10K	1/6W	CARBON	
	R917	QRD167J-104	100K	1/6W	CARBON	
	R918	QRD167J-104	100K	1/6W	CARBON	
	R919	QRD167J-104	100K	1/6W	CARBON	
	R931	QRD12CJ-331S	330	1/2W	R.NETWORK	
	R932	QRD12CJ-331S	330	1/2W	R.NETWORK	
	R933	QRD167J-123	12K	1/6W	CARBON	
	R934	QRD167J-123	12K	1/6W	CARBON	
	R935	QRD167J-102	1K	1/6W	CARBON	
	R936	QRD167J-102	1K	1/6W	CARBON	
	R937	QRD167J-222	2.2K	1/6W	CARBON	
	R938	QRD167J-222	2.2K	1/6W	CARBON	
	R939	QRD167J-102	1K	1/6W	CARBON	
	R940	QRD167J-102	1K	1/6W	CARBON	
	R971	QRD167J-272	2.7K	1/6W	CARBON	
	R972	QRD167J-272	2.7K	1/6W	CARBON	
	R973	QRD167J-393	39K	1/6W	CARBON	
	R974	QRD167J-393	39K	1/6W	CARBON	
	R975	QRD167J-560	56	1/6W	CARBON	
	R976	QRD167J-560	56	1/6W	CARBON	
Δ	R977	QRD14CJ-4R7S	4.7	1/4W	UNF. CARBON	
	R979	QRD167J-102	1K	1/6W	CARBON	
	R980	QRD167J-102	1K	1/6W	CARBON	
	RA901	QRB049J-473	47K	1/10W	R.NETWORK	
	VR931	QVCB84W-E15B	100K		VARIABLE	
	VR932	QVCB84A-E53C	5K		VARIABLE	
	VR951	QVCB84W-E54B	50K		VARIABLE	
	VR971	QVDC91A-E15B	100K		VARIABLE	

Δ : SAFETY PARTS.

Others

Δ	ITEM	PART NUMBER	DESCRIPTION		AREA
		EMW10010-102	CIRCUIT BOARD		
		E3400-431	SPACER		
	J601	EMV5109-011A	PLUG ASSY (11PIN)		
	J931	QMS3R10-E40S	MINI JACK (H.PHONES)		
	J951	QMS3R10-E40S	MINI JACK (MIC)		
	J971	EMV5103-002A	PLUG ASSY (2PIN)		
	L501	EQL0001-R45	INDUCTOR		
	L502	EQL0001-R45	INDUCTOR		
	L531	EQL0001-R45	INDUCTOR		
	L532	EQL0001-R45	INDUCTOR		
	S901	ESP0001-018	TACT SWITCH (POWER)		
	S903	ESP0001-018	TACT SWITCH (SURROUND)		
	S904	ESP0001-018	TACT SWITCH (AI)		
	S905	ESP0001-018	TACT SWITCH (TAPE)		
	S906	ESP0001-018	TACT SWITCH (TUNER)		
	S907	ESP0001-018	TACT SWITCH (CD)		
	S908	ESP0001-018	TACT SWITCH (DAT/VIDEO1)		
	S909	ESP0001-018	TACT SWITCH (AUX/VIDEO2)		
	S910	ESP0001-018	TACT SWITCH (DISPLAY)		
	S911	ESP0001-018	TACT SWITCH (SEA)		
	S912	ESP0001-018	TACT SWITCH (PRESET)		
	S913	ESP0001-018	TACT SWITCH (MEMORY)		
	S914	ESP0001-018	TACT SWITCH (←)		
	S915	ESP0001-018	TACT SWITCH (-)		
	S916	ESP0001-018	TACT SWITCH (+)		
	S917	ESP0001-018	TACT SWITCH (FD)		
	BC971	EMV5109-002A	PLUG ASSY (2PIN)		
	EP002	EWTO11-092	TERMINAL WIRE		C
	EP003	EWTO11-132	TERMINAL WIRE		
	FL901	ELU0001-106	FL TUBE		
	FS901	E3400-420	FELT SPACER		
	FW691	EWR23C-20LN	FLAT WIRE (3PIN)		
	FW911	EWR35B-25LST	FLAT WIRE (5PIN)		
	FW913	EWR23C-30LN	FLAT WIRE (3PIN)		
	FW921	EWR38B-16LST	FLAT WIRE (8PIN)		
	FW960	EMV7122-103	CONNECTOR (3PIN)		A
	JA901	EMV7123-031R	CONNECTOR (31PIN)		
	JB501	EMV7125-010R	CONNECTOR (10PIN)		
	JB531	EMV7125-009R	CONNECTOR (9PIN)		
	JB561	EMV7125-011R	CONNECTOR (11PIN)		
	SRO41	ERT-D2WHK202S	NEGATIVE THERMISTOR		
	TB901	E33754-001	TIE BAND		
	XT901	ECX0060-000EM	RESONATOR		

Δ : SAFETY PARTS.

■ END-075 **A** Power Primary PC Board Ass'y

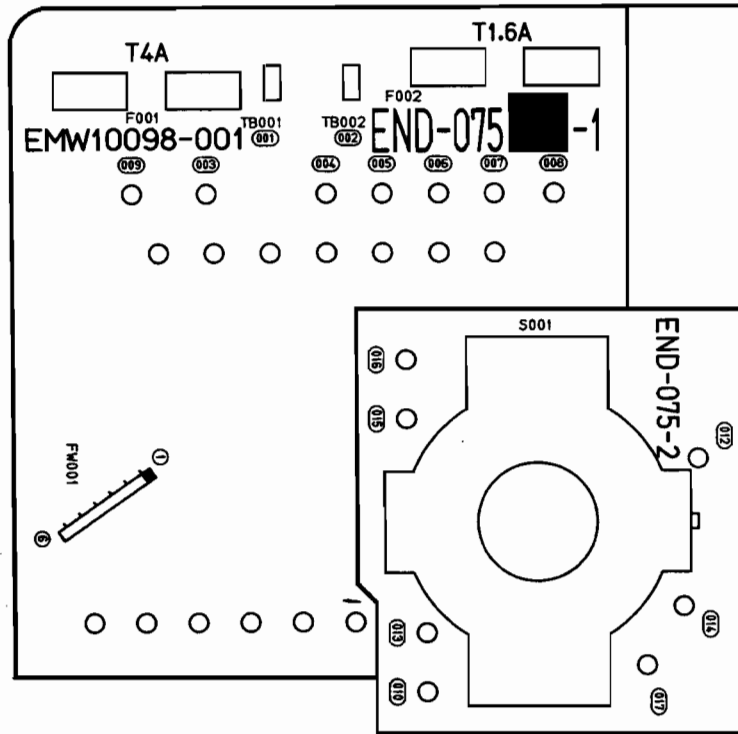

Others

△	ITEM	PART NUMBER	DESCRIPTION	AREA
		EMG7331-001	FUSE CLIP	
		EMW10098-001	CIRCUIT BOARD	
△	S001	QSR0085-018	VOLTAGE SELECTOR	
	F001	EWR369-16KST	FLAT WIRE (6PIN)	
	TB001	E65508-002	TAB	
	TB002	E65508-002	TAB	

△ : SAFETY PARTS

JVC

SERVICE MANUAL

MODEL No. **CA-MX70BK / DX-MX70BK**
(Unit No. TD-MX70BK)



- * For instruction manual , please refer to the CA-MX70BK(SM.No.20243) or DX-MX70BK(SM.No.20249).
- * AX-MX70BK is needed for power supply etc when servicing.

Contents

Safety Precautions	1-2	Adjustment Procedures	1-9
Block Diagram	1-3	Schematic Diagrams	Insertion
Description of Main LSI	1-4	Printed Circuit Board	Insertion
Internal Block Diagram of other ICs	1-5	Connection Diagram	Insertion
Disassembly Procedures	1-7	Parts List	Separate-volume Insertion

Safety Precautions

1. The design of this product contains special hardware and many circuits and components specially for safety purposes. For continued protection, no changes should be made to the original design unless authorized in writing by the manufacturer. Replacement parts must be identical to those used in the original circuits. Services should be performed by qualified personnel only.
2. Alterations of the design or circuitry of the product should not be made. Any design alterations of the product should not be made. Any design alterations or additions will void the manufacturer's warranty and will further relieve the manufacture of responsibility for personal injury or property damage resulting therefrom.
3. Many electrical and mechanical parts in the products have special safety-related characteristics. These characteristics are often not evident from visual inspection nor can the protection afforded by them necessarily be obtained by using replacement components rated for higher voltage, wattage, etc. Replacement parts which have these special safety characteristics are identified in the Parts List of Service Manual. Electrical components having such features are identified by shading on the schematics and by (Δ) on the Parts List in the Service Manual. The use of a substitute replacement which does not have the same safety characteristics as the recommended replacement parts shown in the Parts List of Service Manual may create shock, fire, or other hazards.
4. The leads in the products are routed and dressed with ties, clamps, tubings, barriers and the like to be separated from live parts, high temperature parts, moving parts and/or sharp edges for the prevention of electric shock and fire hazard. When service is required, the original lead routing and dress should be observed, and it should be confirmed that they have been returned to normal, after re-assembling.
5. Leakage current check (Electrical shock hazard testing)
After re-assembling the product, always perform an isolation check on the exposed metal parts of the product (antenna terminals, knobs, metal cabinet, screw heads, headphone jack, control shafts, etc.) to be sure the product is safe to operate without danger of electrical shock.

Do not use a line isolation transformer during this check.

- Plug the AC line cord directly into the AC outlet. Using a "Leakage Current Tester", measure the leakage current from each exposed metal parts of the cabinet, particularly any exposed metal part having a return path to the chassis, to a known good earth ground. Any leakage current must not exceed 0.5mA AC (r.m.s.).

- Alternate check method

Plug the AC line cord directly into the AC outlet. Use an AC voltmeter having, 1,000 ohms per volt or more sensitivity in the following manner. Connect a 1,500 Ω 10 W resistor paralleled by a 0.15 μ F AC-type capacitor between an exposed metal part and a known good earth ground.

Measure the AC voltage across the resistor with the AC voltmeter.

Move the resistor connection to each exposed metal part, particularly any exposed metal part having a return path to the chassis, and measure the AC voltage across the resistor. Now, reverse the plug in the AC outlet and repeat each measurement. Any voltage measured must not exceed 0.75 V AC (r.m.s.). This corresponds to 0.5 mA AC (r.m.s.).

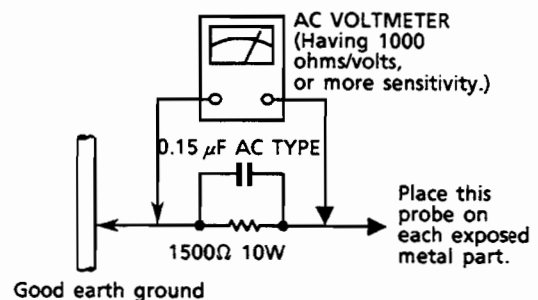

Warning

1. This equipment has been designed and manufactured to meet international safety standards.
2. It is the legal responsibility of the repairer to ensure that these safety standards are maintained.
3. Repairs must be made in accordance with the relevant safety standards.
4. It is essential that safety critical components are replaced by approved parts.
5. If mains voltage selector is provided, check setting for local voltage.

Block Diagram

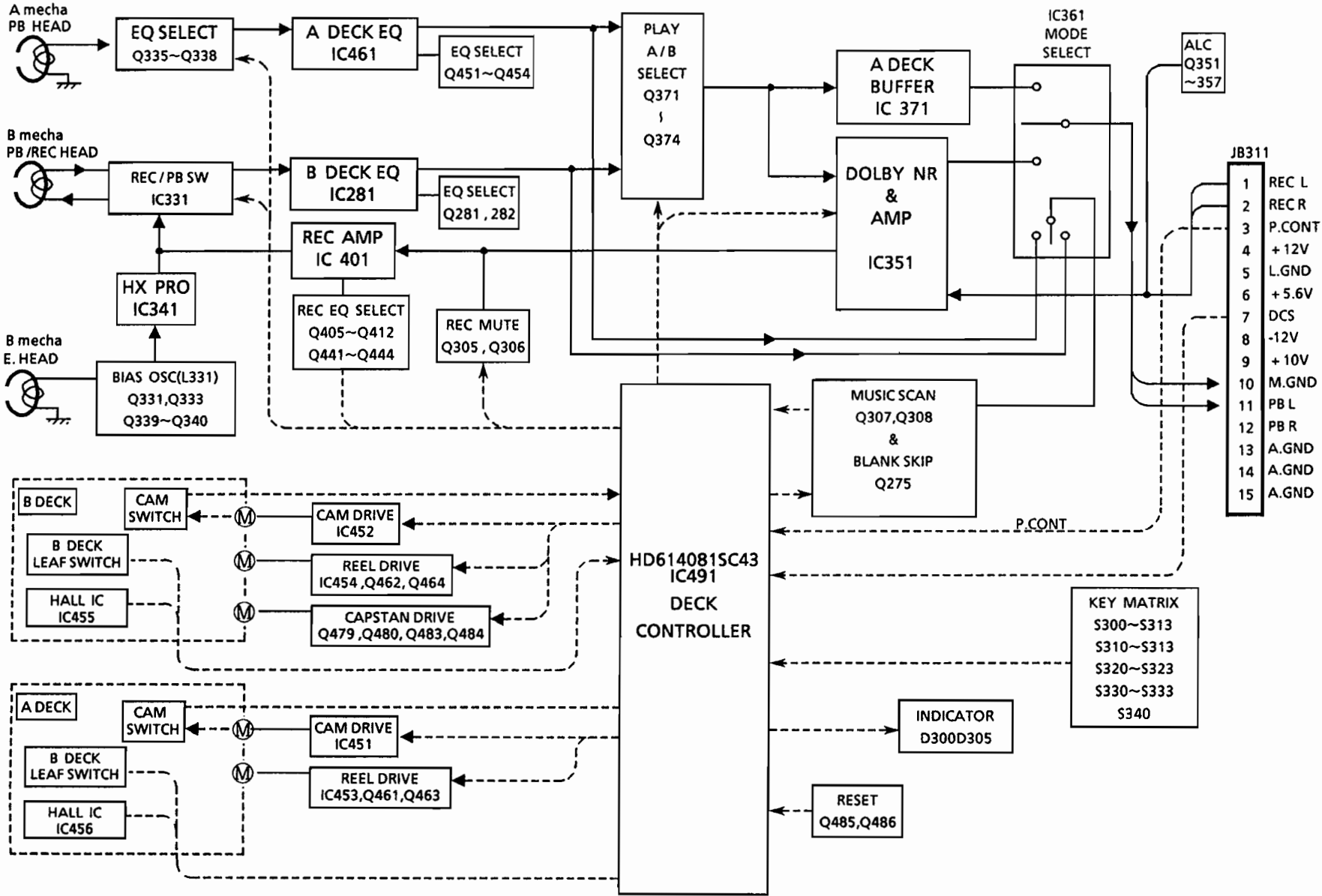

Description of Main LSI

■ HD614081SC43(IC491) : Deck Controller

1. Terminal Layout

A SPEED UP	1	HD614081SC43	64	A FWD PLAY
B SPEED UP	2		63	A REV PLAY
NR OFF	3		62	B FWD PLAY
B NORMAL	4		61	B REV PLAY
CAP CONT	5		60	REC
B REEL FWD	6		59	BLANK SKIP
B REEL REV	7		58	BIAS
B CAM REV	8		57	NR REC
B CAM FWD	9		56	REC MUTE
A CAM SW 2	10		55	DCS IN
A CAM SW 1	11		54	DCS OUT
A CAM SW 0	12		53	GND
A PULSE	13		52	X1
B CAM SW 2	14		51	X2
B CAM SW 1	15		50	TEST
B CAM SW 0	16		49	RESET
B PULSE	17		48	K13
POWER OFF	18		47	K12
MS IN	19		46	K11
A REEL FWD	20		45	K10
A REEL REV	21		44	K03
A CAM REV	22		43	K02
B CAM FWD	23		42	K01
GAIN CONT	24		41	K00
B MUTE	25		40	K04
A MUTE	26		39	K05
O MUTE	27		38	H.S.D
BMS	28		37	HC
REC	29		36	HM
FADE CONT	30		35	HN
BEQ	31		34	LC
VDD	32		33	LM

2. Key Matrix

	KEY IN 0	KEY IN 1	KEY IN 2	KEY IN 3
KEY OUT 0	A◀	A◀◀	A▶▶	A▶
KEY OUT 1	B◀	B◀◀	B▶▶	B▶
KEY OUT 2	A	B	B⊙	B
KEY OUT 3	H.DUB	BLANK SKIP		CD D. REC
KEY OUT 2	B PACK	REV REC	FWD REC	A PACK
KEY OUT 3	REV MODE	B CrO2	B METAL	

3. Pin Function

Pin NO.	symbol	I/O	Function and Operations	Pin NO.	symbol	I/O	Function and Operations
1	A SPEED UP	O	A deck speed control output	33	LM	O	"H" when recording to Metal at N-speed
2	B SPEED UP	O	B deck speed control output	34	LC	O	"H" when recording to CrO2 at N-speed
3	NR OFF	O	NR ON/OFF signal output	35	NH	O	"H" when recording to Normal at H-speed
4	B NORMAL	O	"H" when normal tape in the B Deck	36	HM	O	"H" when recording to Metal at H-speed
5	CAP CONT	O	Capstan control output	37	HC	O	"H" when recording to CrO2 at H-speed
6	B REEL FWD	O	FWD direction control for B reel motor	38	HSD	O	High speed dubbing control signal
7	B REEL REV		REV direction control for B reel motor	39	K05	O	Key matrix output 5
8	B CAM REV		REV direction control for B cam motor	40	K04	O	Key matrix output 4
9	B CAM FWD		FWD direction control for B cam motor	41	K00	O	Key matrix output 0
10	A CAM SW 2		A CAM SW input	42	K01	O	Key matrix output 1
11	A CAM SW 1	O	A CAM SW input	43	K02	O	Key matrix output 2
12	A CAM SW 0	O	A CAM SW input	44	K03	O	Key matrix output 3
13	A PULSE	O	A CAM SW input	45	K10	I	Key matrix input 0
14	B CAM SW 2	I	B CAM SW input	46	K11	I	Key matrix input 1
15	B CAM SW 1	I	B CAM SW input	47	K12	I	Key matrix input 2
16	B CAM SW 0	I	B CAM SW input	48	K13	I	Key matrix input 3
17	B PULSE	I	B CAM SW input	49	RESET	I	Reset signal input
18	POWER OFF	I	Power ON/OFF input	50	TEST	-	Test terminal
19	MS IN	I	Blank detector terminal at music scan	51	X2	I	Clock oscillator input
20	A REEL FWD	O	FWD direction control for A reel motor	52	X1	O	Clock oscillator output
21	A REEL REV	O	REV direction control for A reel motor	53	GND	-	Ground
22	A CAM REV	O	REV direction control for A cam motor	54	DCS OUT	O	Compulink signal output
23	A CAM FWD	O	FWD direction control for A cam motor	55	DCS IN	I	Compulink signal input
24	GAIN CONT	O	Gain control output for M.S amp	56	REC MUTE	O	Recording mute control signal output
25	B MUTE	O	B deck muting control output	57	NR REC	O	NR recording control signal output
26	A MUTE	O	A deck muting control output	58	BIAS	O	"H" with recording
27	O MUTE	O	Play back muting control output	59	BLANK SKIP	O	BLANK SKIP LED control signal output
28	BMS	O	"H" with B deck PB and M.S	60	REC	O	REC LED control signal output
29	REC	O	Recording control ("H" with recording)	61	B REV LED	O	B REV LED control signal output
30	FADE CONT	O	Fade control signal output	62	B FWD LED	O	B FWD LED control signal output
31	BEQ	O	"H" with CrO2 SW off of B deck	63	A REV LED	O	A REV LED control signal output
32	VDD	-	Power supply	64	A FWD LED	O	A FWD LED control signal output

Internal Block Diagram of other ICs

■ HA 12142 (IC351) : Dolby B-C Noise Reduction Amplifier IC

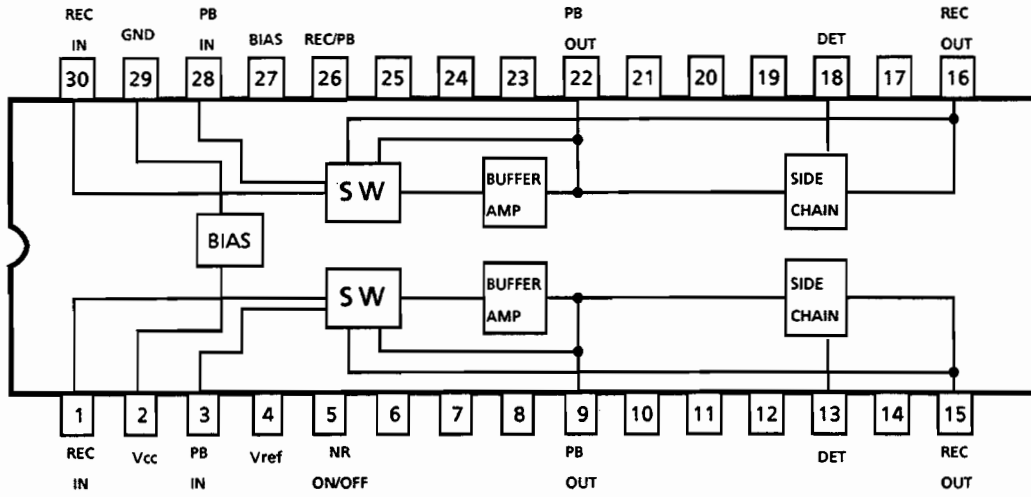

■ μ PC1297CA (IC341) : Dolby HX PRO System IC

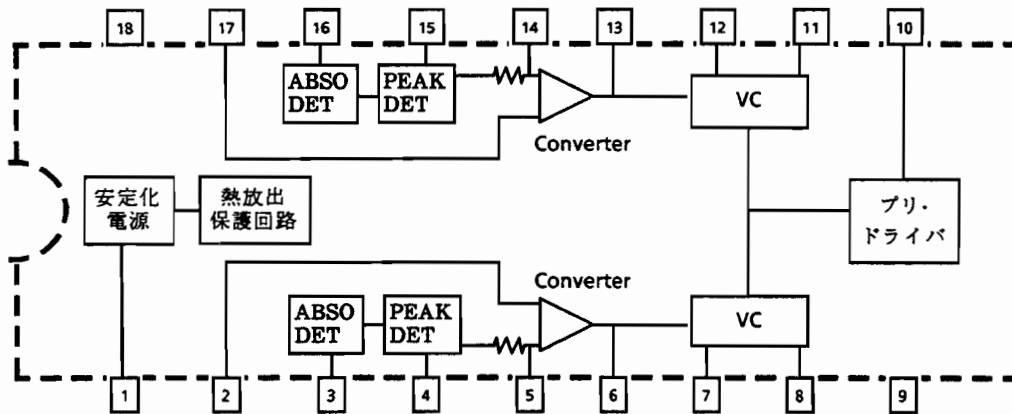

■ LB1639-CV (IC581) : Motor Driver

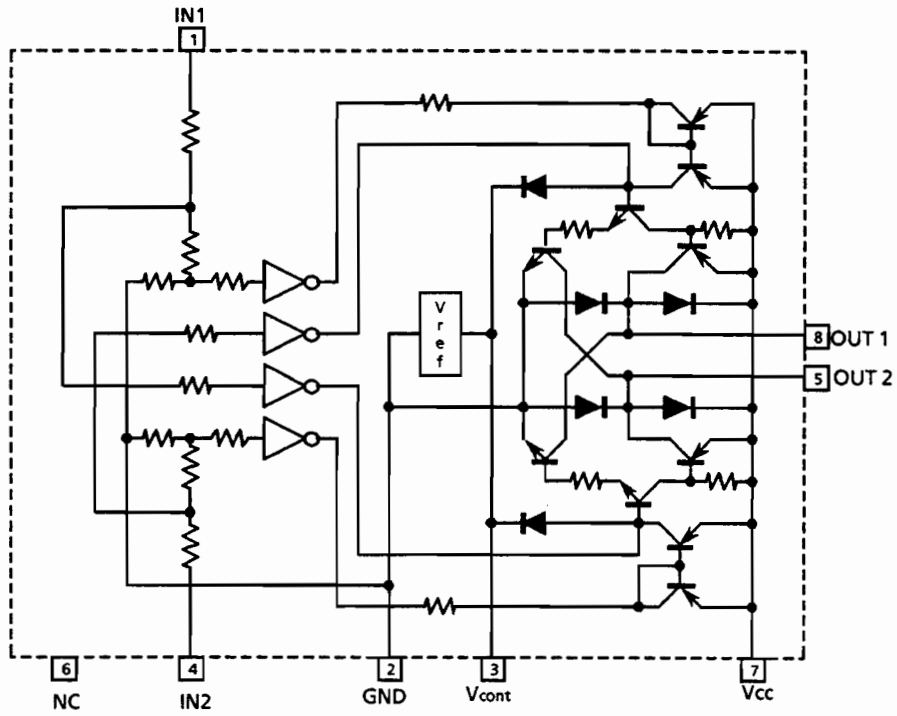

IN 1	IN 2	OUT 1	OUT 2	MOTOR
H	L	H	L	CLOCKWISE
L	H	L	H	COUNTER-CLOCKWISE
H	H	OFF	OFF	WAITING
L	L	OFF	OFF	WAITING

Disassembly Procedures

1. Removing the Top Cover

- (1). Remove 2 screws on both sides of the metal cover.
- (2). Remove 4 screws located on the rear panel.
- (3). Slightly open both sides of the metal cover to the left and right, and raise the rear side. Then slowly lift it up and straight backward.

2. Removing the Front Panel assembly

- (1). Remove the 2 screws "A" fixing the front panel from the bottom, then the 2 screws "B" fixing the mechanism.
- (2). Remove all connectors from the front panel.

3. Removing the Cassette Mechanism

- (1). Remove the 8 screws "C", "D" fixing the cassette mechanism.
Reference : The screw "C" is a doublethread screw for plastics.
The screw "D" is a tap tight screw for chassis.
- (2). Push the EJECT button, then remove the cassette mechanism assembly.

Note : The cassette mechanism is grounded through the bottom cover, so when checking the operations with the bottom cover removed (especially when checking the signal system), be sure to ground the chassis by using an alligator clip or other suitable gadget. Also, as this cassette mechanism is designed for pack sensing, remember that it cannot be operated without any tape.

4. Removing the Cassette Holder

- (1). Remove the gear oil damper fixing with a double-thread screw "E".
- (2). Remove the Holder Spring from the bracket.
- (3). Remove the Cassette Holder from the Holder Bracket.

5. Removing the Cassette Deck Main P.C.B

- (1). Remove the top cover and front panel.
- (2). Remove the 5 screws "F" fixing the Cassette Deck Main P.C.B.
- (3). Unsolder the defective connector J311.

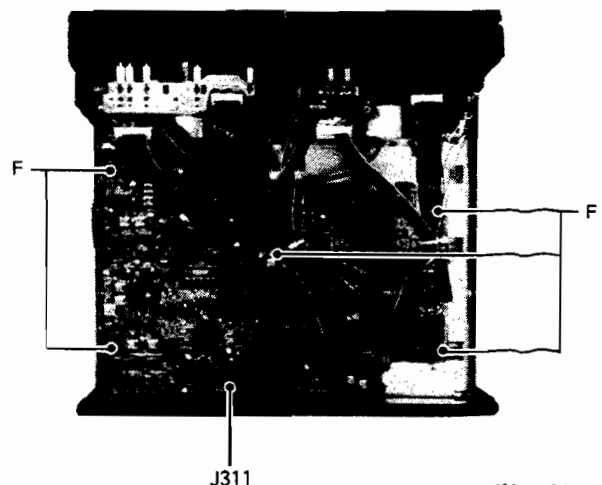
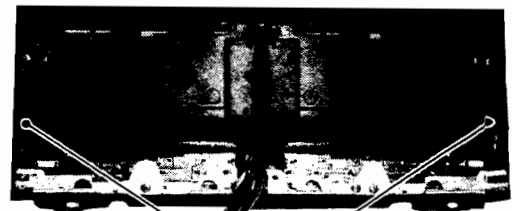
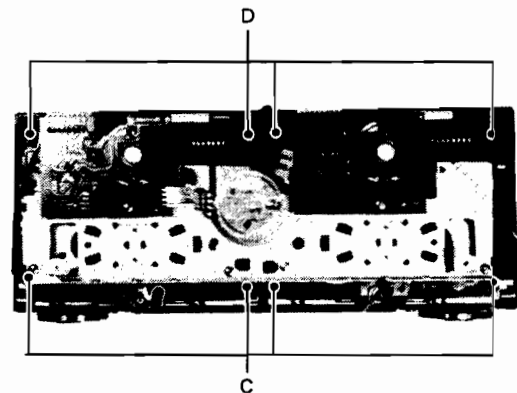
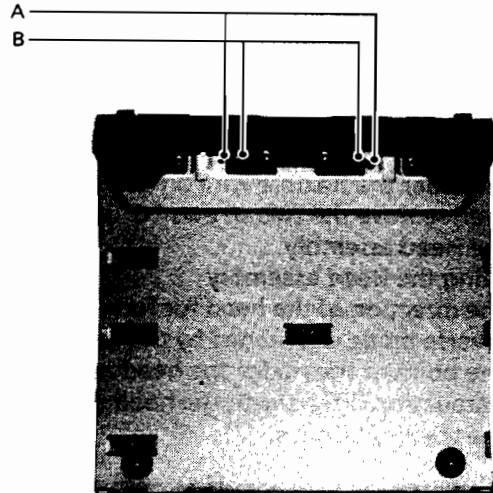

6. Removing the Cassette Mechanism Units

■ Head assembly

1. Unsolder the flexible wire on P.C.Board, then remove the two screws "G" installing the Head assembly.

Installing the Head assembly

1. The direction of the head for forward or reverse mode is switched by the cam gear.
2. The point of the rib for the head assembly installation differs with the head direction.
3. See the right figure.

■ Pinch Roller Arm assembly

1. Detach the Pinch Roller Return Spring (small outside spring) from the hook.
2. Remove the pawl fixing the Pinch Roller Arm assembly.

■ FM Bracket and Flywheel

1. Remove the 6 screws "H" fixing the FM Bracket.
2. Unsolder the reel motor from reel motor P.C.B.
3. Remove the pawl fixing the FM Bracket and Cassette Mechanism assembly.
4. Remove the belt. Fit the belt by the method shown in figure.
5. Detach the Flywheel. (The washer can be removed in the direction of the Pinch Roller)

■ Leaf Switch P.C.B

1. Remove the pawl fixing the Leaf Switch P.C.B.

■ CAM Switch P.C.B

1. Remove the FM Bracket and Flywheel.
2. Remove the pawl fixing the Sensor P.C.B.

■ CAM Motor

1. Remove the Cassette Mechanism assembly on FM Bracket.
2. Remove the pawl fixing the CAM Motor, then remove the motor.

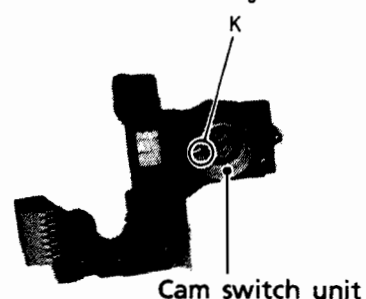
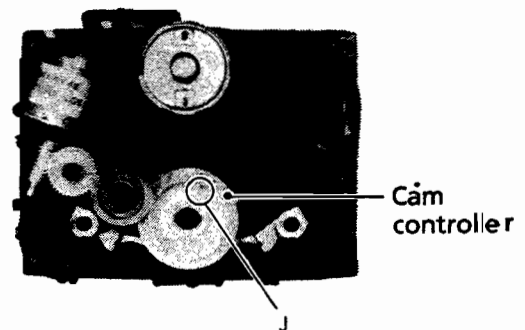
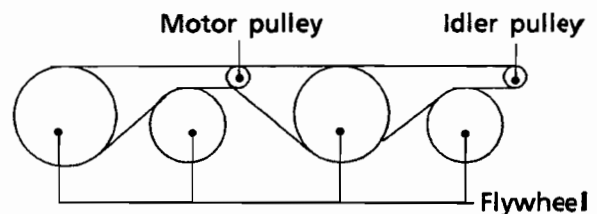
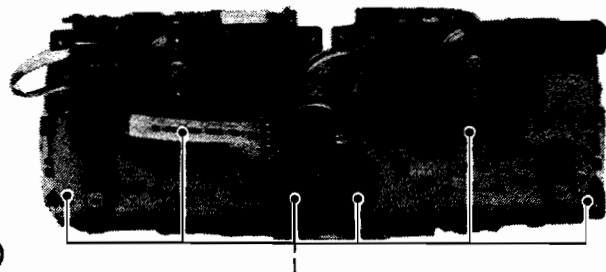
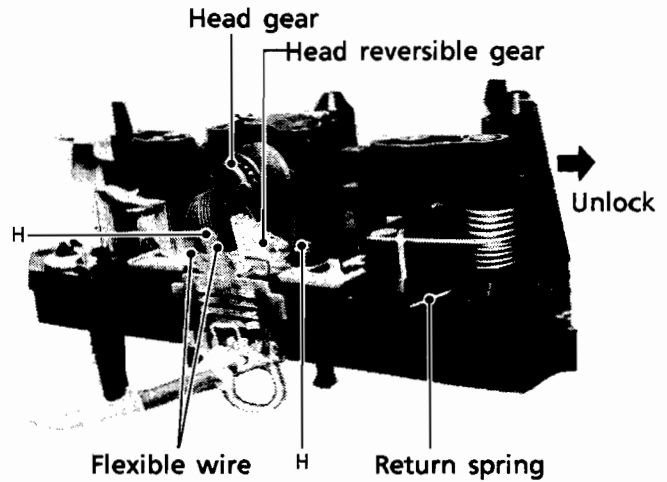
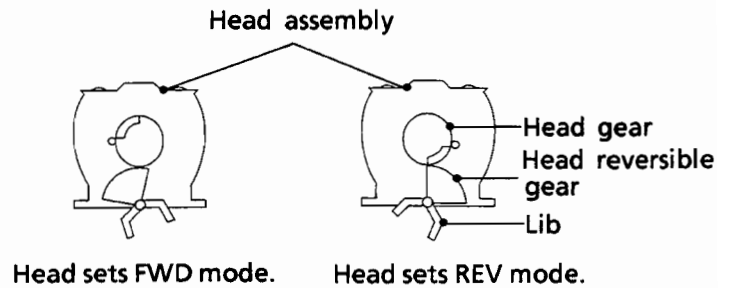

Adjustment Procedures (Cassette Deck)

(1) Measuring instruments for Adjustment

1. Audio frequency signal generator (0dbs output at the 600 ohm output terminal from 50Hz to 20KHz)
2. Attenuator (600 ohm impedance)
3. Electronic voltmeter
4. STANDARD TAPES
VTT-703L(head azimuth adjustment)
VTT-712 (tape speed , wow & flutter)
VTT-724 (Reference level)
5. Recording standard tapes
AC-513 (CrO2), TS-5 (SF) or equivalent. (Use JVC standard tape)
6. 600-ohm resistor for attenuator matching
7. WOW & FLUTTER meter with frequency counter
8. Distortion meter with band-pass filter
9. Torque gauge : CTG-N (cassette type)
10. C-120 tape (for checking the tape running)

(2) Adjustment and repairing the mechanism

(Adjust and inspect the mechanism before adjusting the electronic circuit)

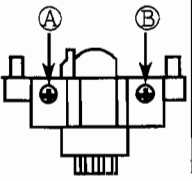
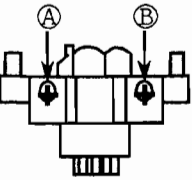
Item	Adjustment Method	Standard value	Remarks
Adjusting azimuth of rec/play head	1. Connect an electronic voltmeter to the VCR/DAT REC terminal. (about 1 volt output) 2. Play back VTT-703L		1) When the specified characteristic cannot be obtained because of head wear, cut wire, excessive magnetization, etc., replace the head and adjust the head azimuth. Also, perform the adjustment of the playback level, recording bias current, recording level, etc.
A mechanism 	3. Adjust screw ① so that the output of the voltmeter becomes maximum when PLAY (▶) is pressed.	Maximum	2) When there is the difference of more than 3 ~ 4 dB between left and right output levels, replace the head to avoid complaints.
	4. Adjust screw ② so that the output of the voltmeter becomes maximum when PLAY (◀) is pressed.	Maximum	
	5. After making the adjustment, apply screw lock to prevent screws ① and ② coming loose .		
B mechanism 	6. Adjust screw ① so that the output of the vltmeter becomes maximum when PLAY (▶) is pressed.	Maximum	
	7. Adjust screw ② so that the output of the voltmeter becomes maximum when PLAY (◀) is pressed.	Maximum	
	8. After making the adjustment, apply screw lock to prevent screws ① and ② coming loose .		
Playback torque	Measure the torque in the playback mode using the torque measurement cassette CTG-N.	26 ~ 62 g-cm	When the standard torque cannot be obtained, replace the FR arm assembly or motor.
Fast forward torque	Measure the torque in the fast forward mode by the above method.	80 ~ 200 g-cm	When the standard torque cannot be obtained, replace the FR arm assembly or motor.
Rewind torque	Measure the torque in the rewind mode by the above method.	80 ~ 200 g-cm	When the standard torque cannot be obtained, replace the FR arm assembly or motor.
Wow & flutter	Play back VTT-712 and connect the wow & flutter meter to the SPK OUT terminals , its reading should be within 0.2% (WRMS).	Less than 0.2%	As a complaint may occur if the wow & flutter fluctuates by 0.1% even though it is allowed in the standard, repairing is required.

(3) Electrical Circuit Adjustments

Make the following adjustments after adjusting the head azimuth.

In principle, the adjustments should be made in the following sequence.

Set the NR switch to OFF and the BEAT CUT switch to "1".

Adjustments marked with an asterisk (*) should always be made after the head is replaced.

Item	Adjustment Method	Adjustment Location	Standard Value	Remarks
Motor speed	1. Play back VTT-712 and connect a frequency counter to the VCR / DAT terminals.	Semi-fixed resistor on the main PC Board		Connect a wow & flutter meter with a built-in frequency counter to the VCR / DAT REC terminal. Adjust the normal speed first, and perform the high speed adjustment.
	2. Normal-speed adjustment Play back deck B and adjust the semi-fixed resistor VR482.	VR482	3,000 ± 10 Hz	
	3. High-speed adjustment Play back deck A and adjust the semi-fixed resistor VR481.	VR481	6000 ± 10Hz	
* 1	Playback level Play back VTT-724 (1 kHz) and connect an electronic voltmeter between W491 and W330 for left, or W329 and W330 for right. And then, adjust the semi - fixed resistors.	A deck (L) VR451 (R) VR452 B deck (L) VR281 (R) VR282	400mV	The playback level varies when the head is replaced so should be adjusted. Use an electronic voltmeter with an impedance of 100 kΩ or more.
* 2	Recording bias frequency Connect a frequency counter between W325 (L), W399(R) and W326(E), and play back a METAL tape.	L331	100 ± 5 kHz	
* 3	HX PRO adjustment Adjust the L341 for L channel (L342 for R channel) so that the DC voltage becomes minimum at both ends of R271 (R272).	L341(L) L342(R)	90~130mV	
* 4	Recording frequency response Record 1 kHz/10 kHz with the NR switch off and input 30mV to VCR /DAT terminals. While playing back these recorded signals, adjust the variation of the 10 kHz outputs from the 1kHz output to the standard value using VR341 and VR342. (Basically, adjust so that the 1 kHz and 10 kHz outputs become flat.)	(L)VR341 (R)VR342	0 ± 3 dB for 10 kHz with 1 kHz as the standard.	1) The recording and playback frequencies of a cassette deck are adjusted by adjusting the bias. This is because the frequency response depends more on the bias current than with an open-reel deck. 2) Perform the adjustment with normal tape and confirm that the values are within the range for metal tape.
	Note: After completing the recording level adjustment in item 3, check the recording and play back frequencies with the NR switch on. Fine adjust again if the value is 0 ± 4 dB or more at 1 kHz and 10 kHz.			

Item	Adjustment Method	Adjustment Location	Standard Value	Remarks	
* 5	Recording Level	1) Input a 1 kHz (300mV) to VCR / DAT terminals and record on the left and right channels . 2) Connect an electronic voltmeter between L and E of NR TR for left, or R and E for right. And then, adjust the semi - fixed resistors when playing back.	(L)VR311 (R)VR312	300mV	Adjust with normal tape and make sure that the level difference is 1.5 dB or less with metal tape and that the left/right level difference is 1.0 dB or less.
* 6	Recording/ playback distortion	1) Input a 1 kHz (300mV) to VCR / DAT terminals and record it. 2) Play it back and check the out-put with a distortion meter to make sure it is the rated value.		less than 2%	Perform after the bias current and recording level adjustments.
7	Recording/ playback S/N ratio	1) Input a 1 kHz (300mV) to VCR / DAT terminals and record it. While recording, remove the input and record without a signal. 2) Play back and use an electronic voltmeter to compare the 0 dB recording output and the out-put of the recording without a signal to make sure this is the rated value.		more than 45 dB	
8	Erase ratio check	1) Input a 1 kHz (950mV) to VCR / DAT terminals and record it. 2) Rewind and erase part of the recorded section. 3) Compare the outputs of the recorded and erased sections using an electronic voltmeter.		more than 55 dB	Connect a 1 kHz band-pass filter between the deck and electronic Voltmeter When making the adjustment.
9	Auto-stop check	When playing back and recording, make sure to operate AUTO STOP.			

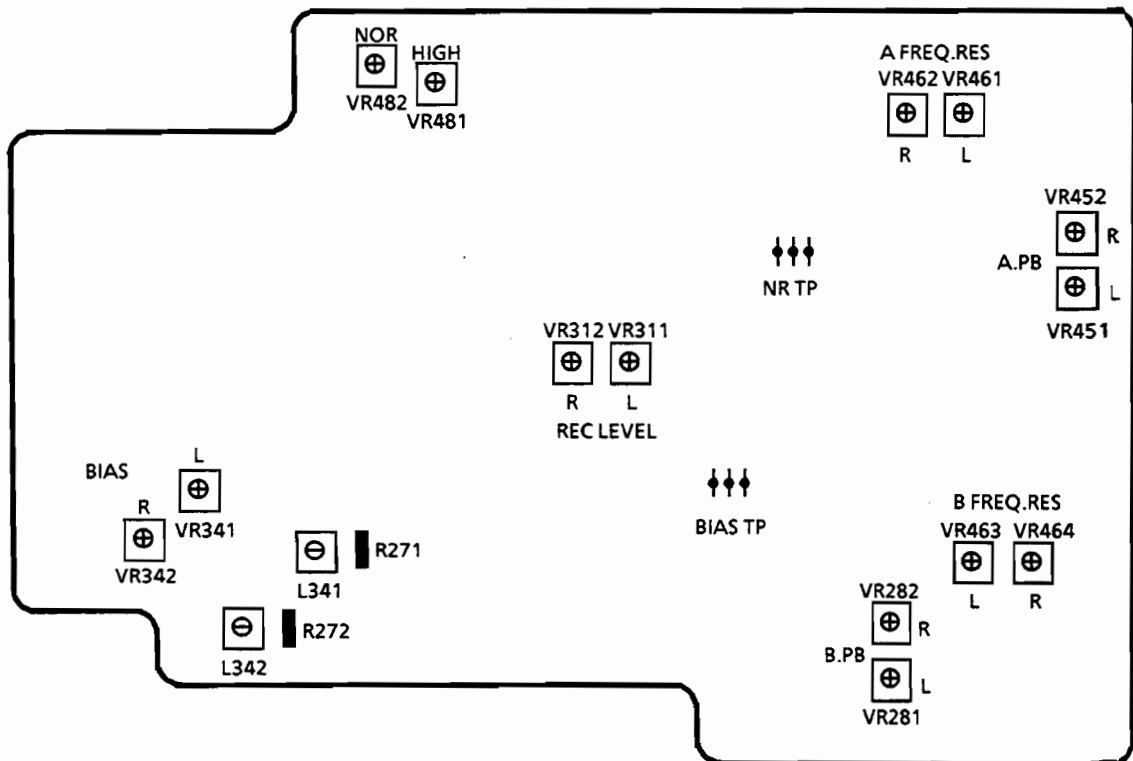

Schematic Diagrams

■ Analog Switch & Power Amplifier Section

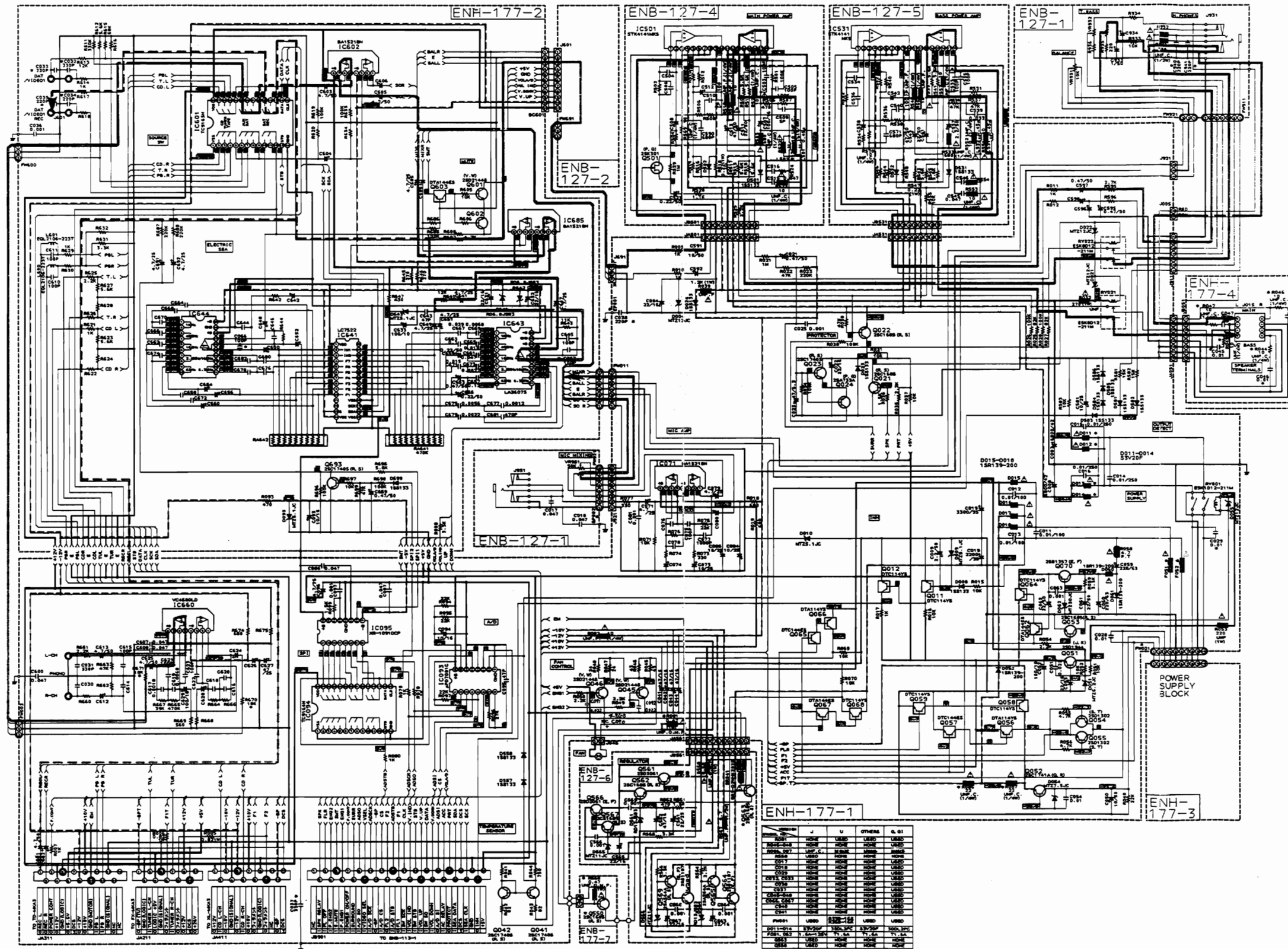

Notes:

1. shows DC voltage applied to the chassis in the stop mode. (Digital section: PLAY mode)
2. indicates positive B power supply.
3. indicates negative B power supply.
4. indicate signal path.
5. When replacing the parts in the darkened are () and those marked with , be sure to use the designated parts to ensure safety.
6. This is the standard circuit diagram
The design and contents are subject to change without notice.

AX-MX70BK AX-MX70BK

System Control & FL Display Section

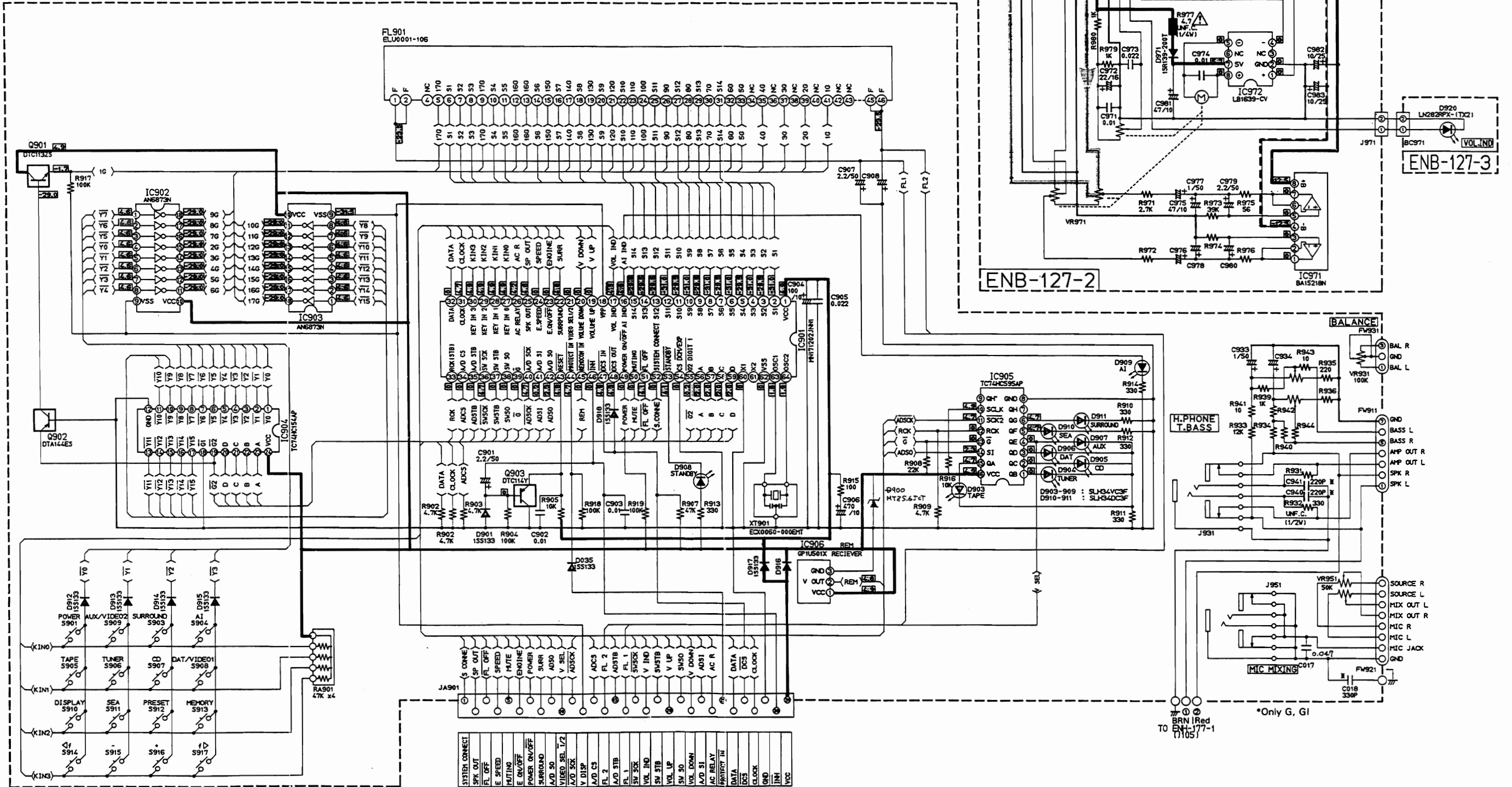

Notes:

1. shows DC voltage applied to the chassis in the stop mode. (Digital section: PLAY mode)
2. indicates positive B power supply.
3. indicates negative B power supply.
4. indicate signal path.
5. When replacing the parts in the darkened are () and those marked with Δ , be sure to use the designated parts to ensure safety.
6. This is the standard circuit diagram
The design and contents are subject to change without notice.

Schematic Diagram

■ Cassette Deck Amp Section

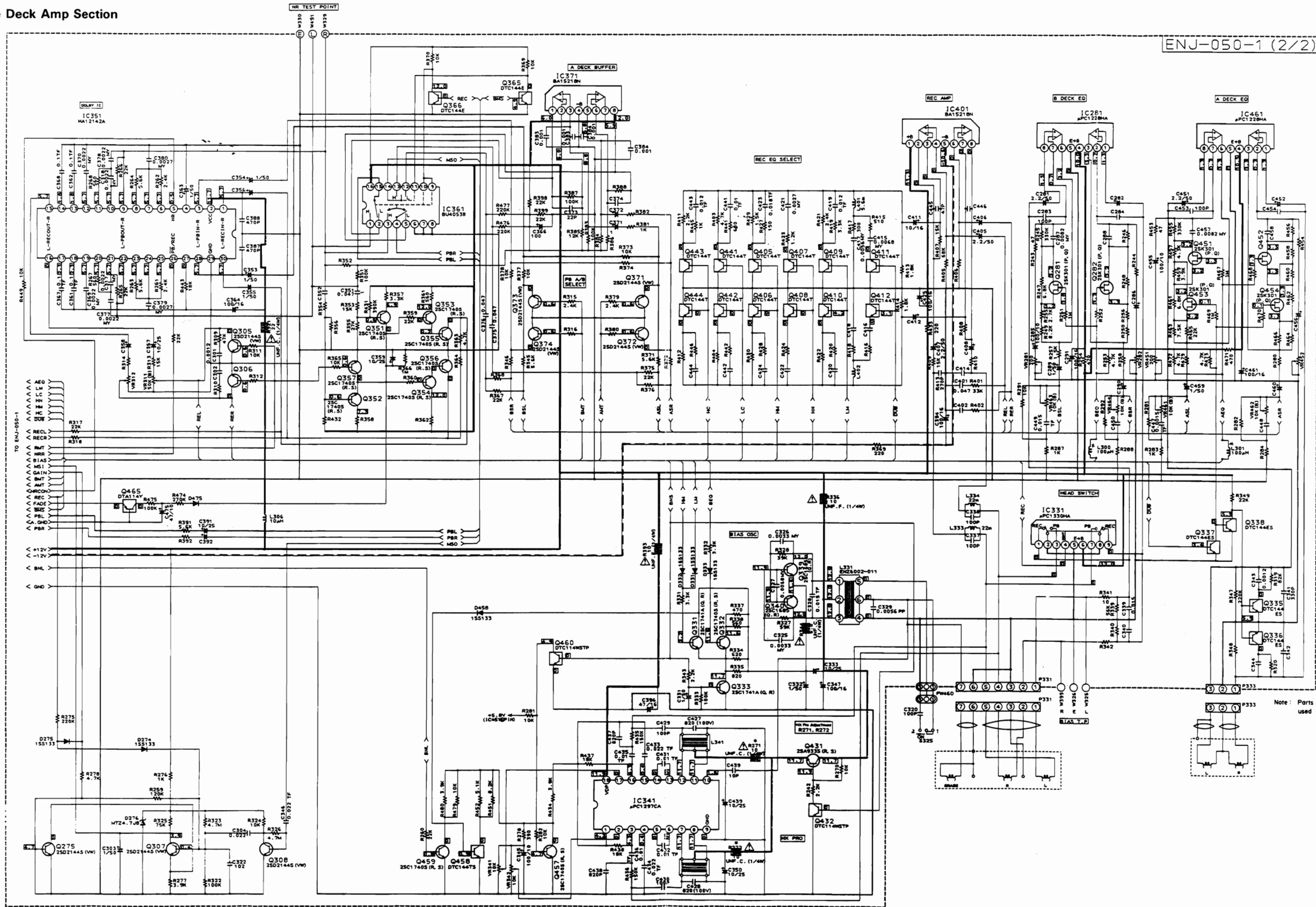

Notes:

1. shows DC voltage to the chassis with no signal input.
2. indicates +B power supply.
3. indicates -B power supply.
4. indicates signal path.
5. When replacing the parts in the darkened area () and those marked with Δ , be sure to use the designated parts to ensure safety.
6. This is the standard circuit diagram.
The design and contents are subject to change without notice.

PARTS LIST

Contents

General Exploded View and Parts List	2-3
Cassette Mechanism Ass'y and Parts List	2-7
Printed Circuit Board Ass'y and Parts List	2-10
■ ENJ-050 □ Cassette PC Board Ass'y	2-10

Connection Diagram

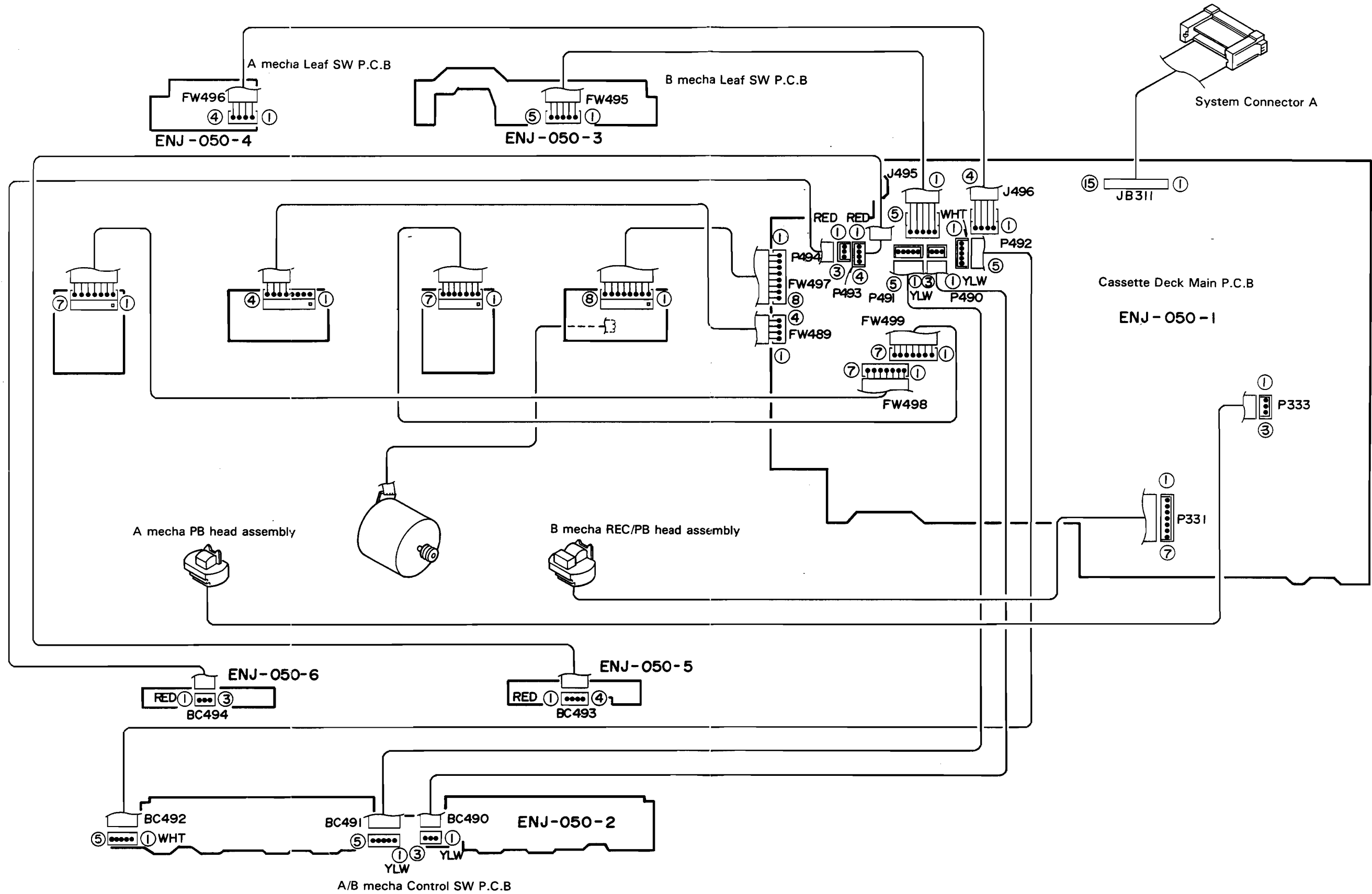

General Exploded View and Parts List

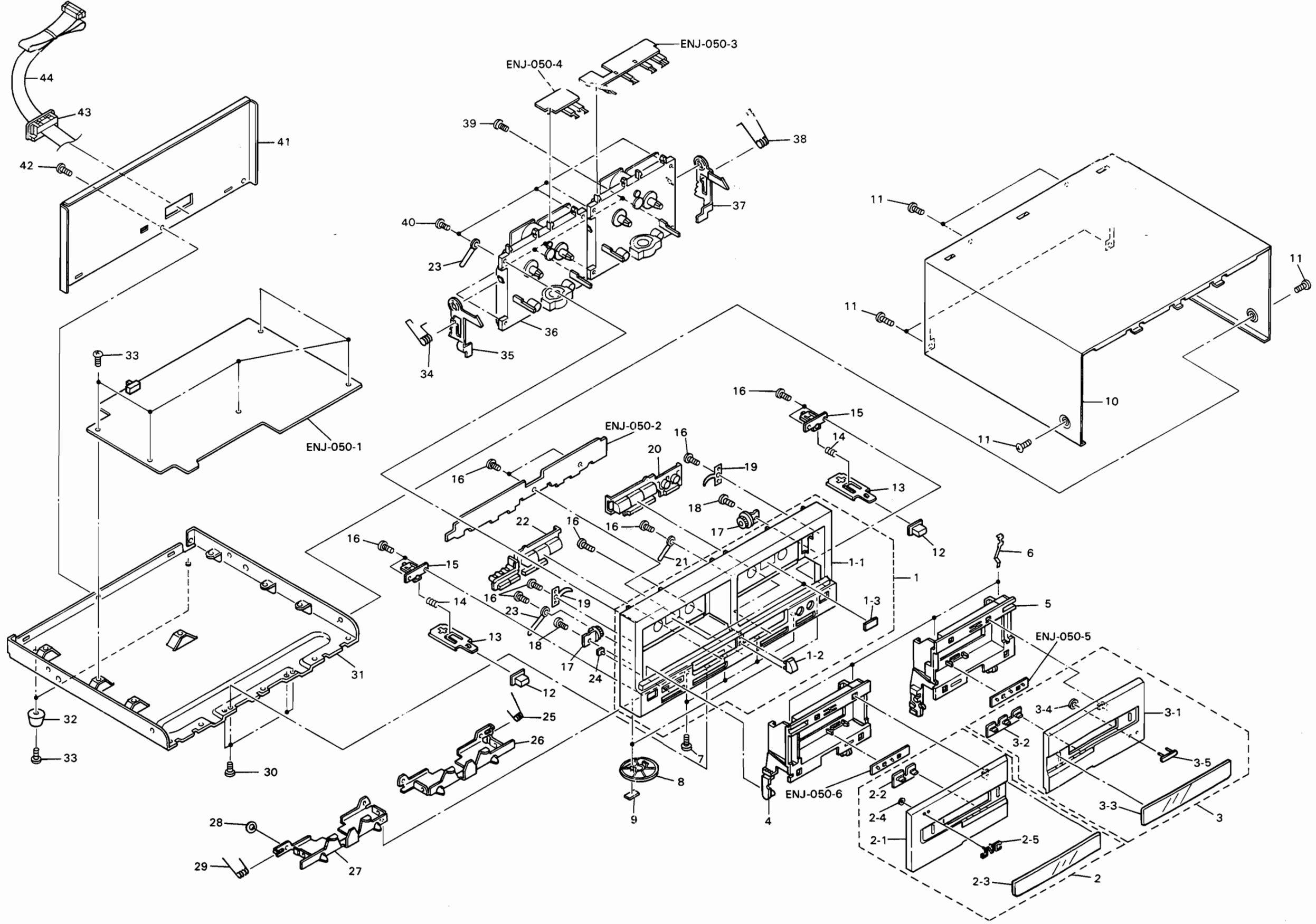

Parts List

Item	Part Number	Part Name	Q'ty	Description	Areas
1	EFP-TDMX70BKE(S)	Front Panel Ass'y	1		
1-1	E102325-005	Front Panel	1		
1-2	E406110-001	Cap	1		
1-3	E69777-003	Reflection Plate	2		
2	E307065-003SA	Cassette Lid Ass'y	1	A	
2-1	E307065-003	Cassette Lid	1	A	
2-2	E406100-001	Indicator	1	A	
2-3	E406193-001	Cassette Window	1	A	
2-4	E60912-003	Speed Nut	1	A	
2-5	PQ42561	JVC Mark	1	A	
3	E307067-002SA	Cassette Lid Ass'y	1	B	
3-1	E307067-002	Cassette Lid	1	B	
3-2	E406099-001	Indicator	1	B	
3-3	E406193-002	Cassette Window	1	B	
3-4	E60912-003	Speed Nut	1	B	
3-5	E406347-001	Mark	1	B	
4	E206813-002	Cassette Holder	1	A	
5	E206814-002	Cassette Holder	1	B	
6	E406085-001	Cassette Spring	4		
7	SDST3006Z	Screw	4		
8	E306935-001	Foot	2	Front	
9	E75896-001	Spacer	2	for Front Foot	
10	E206809-002	Metal Cover	1		
11	SDSG3008M	Screw	6		
12	E406097-002	Push Button	2	Eject	
13	E406103-001	Push Plate	2	Eject	
14	E406112-001	Spring	2	Eject	
15	E306938-003	Eject Guide	2	Eject	
16	SDSF2608Z	Screw	11		
17	E305654-003	Damper Ass'y	2		
18	SBSF3008Z	Screw	2	for Damper	
19	E406251-001	Leaf Spring	2		
20	E206821-003	Push Button	1	B	
21	PU49485-4	Wire Clamp	1		
22	E206811-002	Push Button	1	A	
23	PU49485-3	Wire Clamp	2		
24	E406111-001	Indicator	1	B.Skip	
25	E406276-001	Holder Spring	1	Right	
26	E306911-002	Holder Bracket	1	Right	
27	E306910-002	Holder Bracket	1	Left	
28	E406359-001	Spacer	1	for Holder Bracket (Left)	
29	E406275-002	Holder Spring	1	Left	
30	SDST3006M	Screw	4		
31	E102327-002	Chassis Base	1		
32	E47227-029	Foot	2	Rear	
33	SBSG3008N	Screw	7		
34	E406277-003	Eject Spring	1	Left	
35	E307099-003	Eject Lever	1	Left	
36		Cassette Mechanism Ass'y	1	See page 2-7	
37	E307100-004	Eject Lever	1	Right	
38	E406278-002	Eject Spring	1	Right	
39	SBST3008C	Screw	4	for Cassette Mechanism	
40	SBSF3010C	Screw	4	for Cassette Mechanism	
41	E206823-009	Rear Panel	1		J
	E206823-010	Rear Panel	1		C,U,A

△: Safety Parts

Item	Part Number	Part Name	Q'ty	Description	Areas
	E206823-011	Rear Panel	1		E, EF, G, GI
	E206823-012	Rear Panel	1		BS
42	SBSG3008M	Screw	1		
43	E305920-001	Cord Holder	1		
44	EWP902-021	Plug Cord Ass'y	1	JB311 (15Pin)	
—	E61029-009	Number Label	1		

△: Safety Parts

The Marks Designated Areas

J.....the U.S.A.
 C.....Canada
 A.....Australia
 G.....Germany
 GI.....Italy

BS.....the U.K.
 E, EF.....Continental Europe
 U.....Universal Type
 No mark indicates all areas.

Cassette Mechanism Ass'y and Parts List

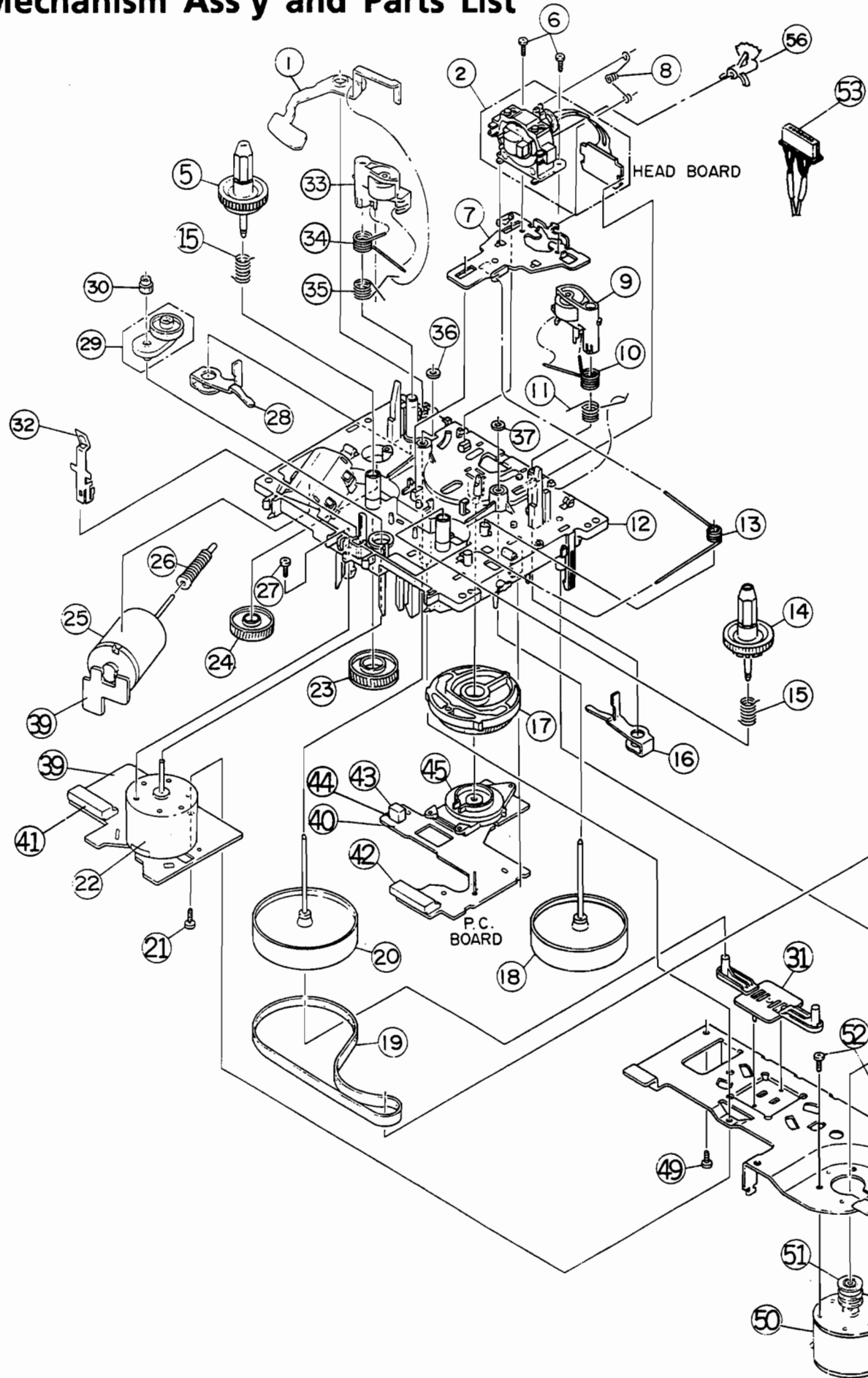

(No. 20246) 2-7

A

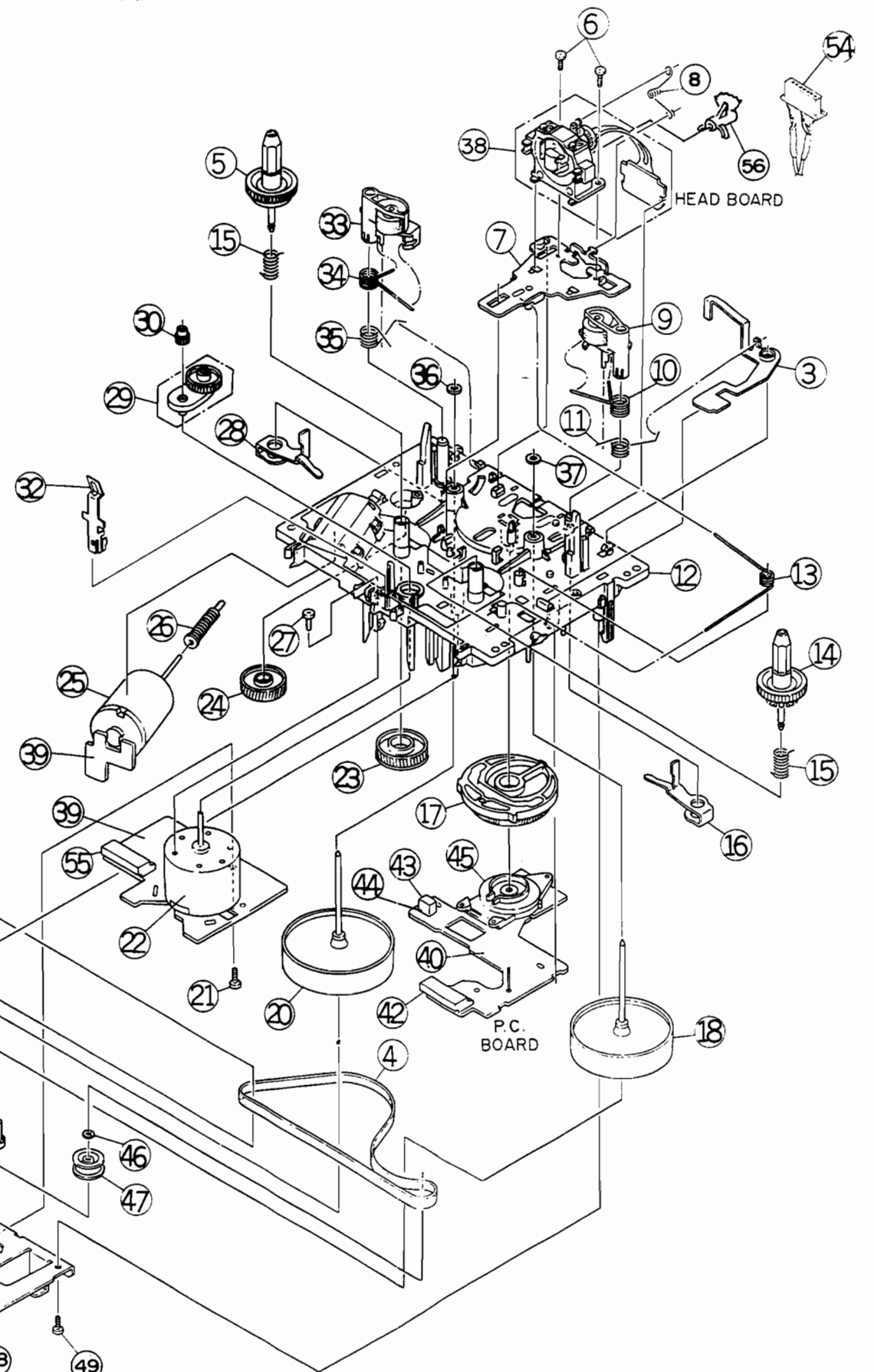

(No. 20246) 2-8

Cassette Mechanism Parts List

Item	Part Number	Part Name	Q'ty	Description	Areas
1	VKL6954-002	Eject Safety Lever	1	B Mechanism	
2	VDG5149-002MB1	Head Mount Ass'y	1	B Mechanism	
3	VKL6943-002	Eject Safety Lever	1	A Mechanism	
4	VKB3001-047	Capstan Belt	1	A Mechanism	
5	VKS5321-00A	Reel Ass'y	2	Right	
6	SDST2004Z	Screw	4	for Head Mount Ass'y	
7	VKL6942-00B	Head Base Ass'y	2		
8	VKW4914-001	Head Spring	2		
9	VKP4221-00A	Pinch Roller Ass'y	2	Left	
10	VKW3006-213	Torsion Spring	2	Left	
11	VKW4933-001	Torsion Spring	2	Left	
12	VKS1112-00A	Chassis Base Ass'y	2		
13	VKW4930-002	Return Spring	2		
14	VKS3480-001	Reel Ass'y	2	Left	
15	VKW4928-001	B.T Spring	4	for Reel Ass'y	
16	VKL6940-001	Pinch Roller Lever	2	Left	
17	VKS2209-002	Controller Cam	2		
18	VKF3174-00A	Flywheel Ass'y	2	Left	
19	VKB3001-048	Capstan Belt	1	B Mechanism	
20	VKF3172-00A	Flywheel Ass'y	2	Right	
21	SDSF2608Z	Screw	2		
22	MMN-6F4RA88	D.C Motor	2	Reel	
23	VKS5331-001	Gear (6)	2		
24	VKS5330-001	Gear (5)	2		
25	MXN-13FB12F	D.C Motor	2	Cam	
26	VKS5329-001	Gear (4)	2		
27	SDSP2605Z	Screw	2		
28	VKL6939-001	Pinch Roller Lever	2	Right	
29	VKS5325-00B	FR Arm Ass'y	2		
30	VKS5328-002	Reel Motor Gear	2		
31	VKS5327-002	Thrust Plate	2		
32	VKY4628-001	Pack Spring	2		
33	VKP4219-00A	Pinch Roller Ass'y	2	Right	
34	VKW3006-212	Torsion Spring	2	Right	
35	VKW4932-001	Torsion Spring	2	Right	
36	VKZ4035-009	Washer	2	Right	
37	Q03093-527	Washer	2	Left	
38	VDG5149-002MA1	Head Mount Ass'y	1	A Mechanism	
39	VMW3272-001	Printed Board	2		
40	VMW3273-001	Printed Board	2		
41	VMC0107-R08	Connector	1	B Mechanism	
42	VMC0107-R07	Connector	2		
43	DN6851A	Hall IC	2		
44	VKS3487-001	IC Holder	2		
45	VKS3495-00A	Cam Switch Ass'y	2		
46	WDL163525-4	Washer	1		
47	VKR4631-002	Idler Pulley	1		
48	VKM3419-00C	FM Bracket	1		
49	SDSF2605Z	Screw	4		
50	MMI-6H2LWSK	Motor	1	Capstan	
51	VKR4632-001	Motor Pulley	1		
52	SPSP2603Z	Screw	2		
53	VDM007P-040	Head Wire	1	B Mechanism	
54	VDM003P-040	Head Wire	1	A Mechanism	
55	VMC0107-R04	Connector	1	A Mechanism	
56	VKS3485-002	Head Block Gear	2		

Printed Circuit Board Ass'y and Parts List

■ ENJ-050 □ Cassette PC Board Ass'y

Note : ENJ-050 □ varies according to the areas employed. See note (1) when placing an order.

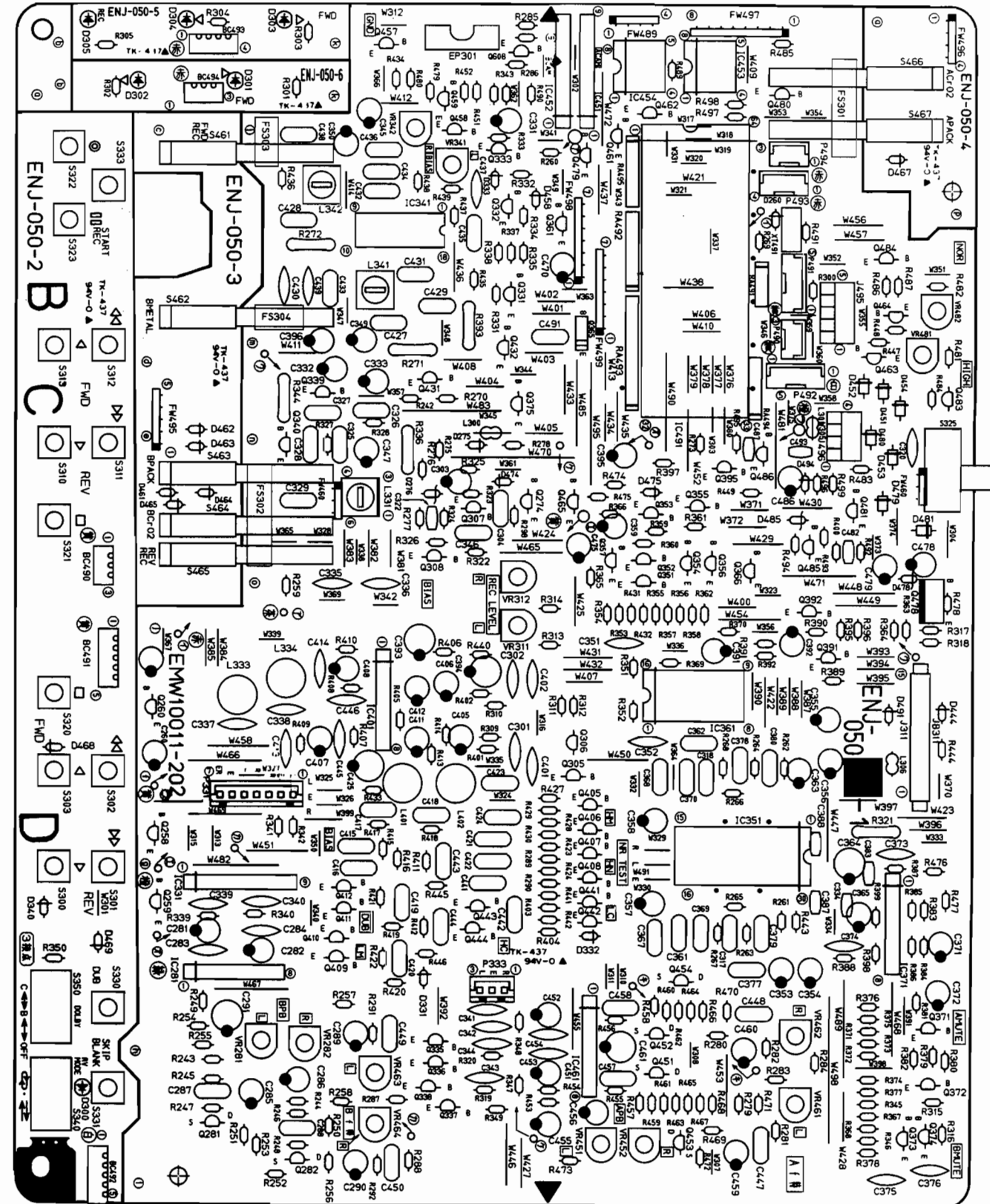

Capacitors

Δ	ITEM	PART NUMBER	DESCRIPTION			AREA
	C339	QCY21HK-152	1500PF	50V	CERAMIC	
	C340	QCY21HK-152	1500PF	50V	CERAMIC	
	C341	QCS21HJ-331	330PF	50V	CERAMIC	
	C342	QCS21HJ-331	330PF	50V	CERAMIC	
	C343	QCY21HK-122	1200PF	50V	CERAMIC	
	C344	QCY21HK-122	1200PF	50V	CERAMIC	
	C345	QETB1AM-107	100MF	10V	ELECTRO	
	C346	QFVB1HJ-223	0.022MF	50V	T.FILM	
	C347	QETB1CM-107	100MF	16V	ELECTRO	
	C349	QETB1EM-106	10MF	25V	ELECTRO	
	C350	QETB1EM-106	10MF	25V	ELECTRO	
	C351	QCF21HP-473	0.047MF	50V	CERAMIC	
	C352	QCF21HP-473	0.047MF	50V	CERAMIC	
	C353	QETB1HM-105	1MF	50V	ELECTRO	
	C354	QETB1HM-105	1MF	50V	ELECTRO	
	C355	QETB1HM-105	1MF	50V	ELECTRO	
	C356	QETB1HM-105	1MF	50V	ELECTRO	
	C357	QETB1EM-106	10MF	25V	ELECTRO	
	C358	QETB1EM-106	10MF	25V	ELECTRO	
	C359	QETB1EM-106	10MF	25V	ELECTRO	
	C361	QFVB1HJ-104	0.1MF	50V	T.FILM	
	C362	QFVB1HJ-104	0.1MF	50V	T.FILM	
	C363	QETB1HM-105	1MF	50V	ELECTRO	
	C364	QETB1CM-107	100MF	16V	ELECTRO	
	C365	QETB1AM-107	100MF	10V	ELECTRO	
	C367	QFVB1HJ-104	0.1MF	50V	T.FILM	
	C368	QFVB1HJ-104	0.1MF	50V	T.FILM	
	C369	QFLB1HJ-222	2200PF	50V	MYLAR	
	C370	QFLB1HJ-222	2200PF	50V	MYLAR	
	C371	QETB1HM-105	1MF	50V	ELECTRO	
	C372	QETB1HM-105	1MF	50V	ELECTRO	
	C373	QCS21HJ-220	22PF	50V	CERAMIC	
	C374	QCS21HJ-220	22PF	50V	CERAMIC	
	C375	QCF21HP-473	0.047MF	50V	CERAMIC	
	C376	QCF21HP-473	0.047MF	50V	CERAMIC	
	C377	QFLB1HJ-222	2200PF	50V	MYLAR	
	C378	QFLB1HJ-222	2200PF	50V	MYLAR	
	C379	QFLB1HJ-272	2700PF	50V	MYLAR	
	C380	QFLB1HJ-272	2700PF	50V	MYLAR	
	C383	QCGB1HK-102	1000PF	50V	CERAMIC	
	C384	QCGB1HK-102	1000PF	50V	CERAMIC	
	C387	QCB1HK-471	470PF	50V	CERAMIC	
	C388	QCB1HK-471	470PF	50V	CERAMIC	
	C391	QEK51EM-106	10MF	25V	ELECTRO	
	C392	QEK51EM-106	10MF	25V	ELECTRO	
	C393	QETB1CM-107	100MF	16V	ELECTRO	
	C394	QETB1CM-107	100MF	16V	ELECTRO	
	C395	QETB1AM-476	47MF	10V	ELECTRO	
	C396	QETB1CM-476	47MF	16V	ELECTRO	
	C401	QCF21HP-473	0.047MF	50V	CERAMIC	
	C402	QCF21HP-473	0.047MF	50V	CERAMIC	
	C405	QETB1HM-225	2.2MF	50V	ELECTRO	
	C406	QETB1HM-225	2.2MF	50V	ELECTRO	
	C407	QETB1HM-225	2.2MF	50V	ELECTRO	
	C408	QETB1HM-225	2.2MF	50V	ELECTRO	
	C411	QETB1EM-106	10MF	25V	ELECTRO	
	C412	QETB1EM-106	10MF	25V	ELECTRO	
	C413	QCS21HJ-271	270PF	50V	CERAMIC	
	C414	QCS21HJ-271	270PF	50V	CERAMIC	
	C415	QFLB1HJ-682	6800PF	50V	MYLAR	
	C416	QFLB1HJ-682	6800PF	50V	MYLAR	
	C417	QFLB1HJ-562	5600PF	50V	MYLAR	
	C418	QFLB1HJ-562	5600PF	50V	MYLAR	
	C419	QFVB1HJ-123	0.012MF	50V	T.FILM	
	C420	QFVB1HJ-123	0.012MF	50V	T.FILM	
	C421	QFLB1HJ-272	2700PF	50V	MYLAR	
	C422	QFLB1HJ-272	2700PF	50V	MYLAR	
	C423	QFVB1HJ-183	0.018MF	50V	T.FILM	
	C424	QFVB1HJ-183	0.018MF	50V	T.FILM	
	C425	QETB1CM-107	100MF	16V	ELECTRO	
	C427	QFPB1HG-821	820PF	50V	POLY	
	C428	QFPB1HG-821	820PF	50V	POLY	
	C429	QCS21HJ-101	100PF	50V	CERAMIC	
	C430	QCS21HJ-101	100PF	50V	CERAMIC	
	C431	QFVB1HJ-333	0.033MF	50V	T.FILM	
	C432	QFVB1HJ-333	0.033MF	50V	T.FILM	
	C433	QFVB1HJ-223	0.022MF	50V	T.FILM	
	C434	QFVB1HJ-223	0.022MF	50V	T.FILM	
	C435	QFVB1HJ-103	0.01MF	50V	T.FILM	
	C436	QFVB1HJ-103	0.01MF	50V	T.FILM	
	C437	QCF21HP-102	1000PF	50V	CERAMIC	
	C438	QCF21HP-102	1000PF	50V	CERAMIC	
	C439	QCS21HJ-100	10PF	50V	CERAMIC	
	C441	QFVB1HJ-103	0.01MF	50V	T.FILM	
	C442	QFVB1HJ-103	0.01MF	50V	T.FILM	
	C443	QFVB1HJ-123	0.012MF	50V	T.FILM	
	C444	QFVB1HJ-123	0.012MF	50V	T.FILM	
	C445	QCS21HJ-470	47PF	50V	CERAMIC	
	C446	QCS21HJ-470	47PF	50V	CERAMIC	
	C447	QFVB1HJ-153	0.015MF	50V	T.FILM	
	C448	QFVB1HJ-153	0.015MF	50V	T.FILM	
	C449	QFVB1HJ-153	0.015MF	50V	T.FILM	
	C450	QFVB1HJ-153	0.015MF	50V	T.FILM	
	C451	QETB1HM-225	2.2MF	50V	ELECTRO	
	C452	QETB1HM-225	2.2MF	50V	ELECTRO	

Δ : SAFETY PARTS

Capacitors

Δ	ITEM	PART NUMBER	DESCRIPTION			AREA
	C453	QCS21HJ-101	100PF	50V	CERAMIC	
	C454	QCS21HJ-101	100PF	50V	CERAMIC	
	C455	QETB1AM-107	100MF	10V	ELECTRO	
	C456	QETB1AM-107	100MF	10V	ELECTRO	
	C457	QFLB1HJ-822	8200PF	50V	MYLAR	
	C458	QFLB1HJ-822	8200PF	50V	MYLAR	
	C459	QETB1HM-105	1MF	50V	ELECTRO	
	C460	QETB1HM-105	1MF	50V	ELECTRO	
	C461	QETB1CM-107	100MF	16V	ELECTRO	
	C475	QETB1AM-476	47MF	10V	ELECTRO	
	C478	QETB1EM-106	10MF	25V	ELECTRO	
	C479	QETB1AM-476	47MF	10V	ELECTRO	
	C482	QCVB1CM-103	0.01MF	16V	CERAMIC	
	C486	QETB1CM-106	10MF	16V	ELECTRO	
	C487	QCVB1CM-103	0.01MF	16V	CERAMIC	
	C491	QCZ0202-155	1.5MF	25V	CERAMIC	
	C493	QCVB1CM-103	0.01MF	16V	CERAMIC	
	C494	QCF21HP-103	0.01MF	50V	CERAMIC	

Δ : SAFETY PARTS

Resistors

Δ	ITEM	PART NUMBER	DESCRIPTION			AREA
	R242	QRD167J-222	2.2K	1/6W	CARBON	
	R243	QRD167J-470	47	1/6W	CARBON	
	R244	QRD167J-470	47	1/6W	CARBON	
	R245	QRD167J-334	330K	1/6W	CARBON	
	R246	QRD167J-334	330K	1/6W	CARBON	
	R247	QRD167J-682	6.8K	1/6W	CARBON	
	R248	QRD167J-682	6.8K	1/6W	CARBON	
	R249	QRD167J-822	8.2K	1/6W	CARBON	
	R250	QRD167J-822	8.2K	1/6W	CARBON	
	R251	QRD167J-105	1M	1/6W	CARBON	
	R252	QRD167J-105	1M	1/6W	CARBON	
	R253	QRD167J-472	4.7K	1/6W	CARBON	
	R254	QRD167J-471	470	1/6W	CARBON	
	R255	QRD167J-272	2.7K	1/6W	CARBON	
	R256	QRD167J-272	2.7K	1/6W	CARBON	
	R257	QRD167J-102	1K	1/6W	CARBON	
	R258	QRD167J-102	1K	1/6W	CARBON	
	R259	QRD167J-472	4.7K	1/6W	CARBON	
	R260	QRD167J-102	1K	1/6W	CARBON	
	R261	QRD167J-242	2.4K	1/6W	CARBON	
	R262	QRD167J-242	2.4K	1/6W	CARBON	
	R263	QRD167J-562	5.6K	1/6W	CARBON	
	R264	QRD167J-562	5.6K	1/6W	CARBON	
	R265	QRD167J-223	22K	1/6W	CARBON	
	R266	QRD167J-223	22K	1/6W	CARBON	
	R267	QRD167J-561	560	1/6W	CARBON	
	R268	QRD167J-561	560	1/6W	CARBON	
	R269	QRD167J-103	10K	1/6W	CARBON	
	R270	QRD167J-103	10K	1/6W	CARBON	
	R271	QRD14CJ-100S	10	1/4W	UNF. CARBON	
	R272	QRD14CJ-100S	10	1/4W	UNF. CARBON	
	R273	QRD167J-222	2.2K	1/6W	CARBON	
	R275	QRD167J-224	220K	1/6W	CARBON	
	R276	QRD167J-102	1K	1/6W	CARBON	
	R277	QRD167J-392	3.9K	1/6W	CARBON	
	R278	QRD167J-472	4.7K	1/6W	CARBON	
	R279	QRD167J-102	1K	1/6W	CARBON	
	R280	QRD167J-102	1K	1/6W	CARBON	
	R281	QRD167J-223	22K	1/6W	CARBON	
	R282	QRD167J-223	22K	1/6W	CARBON	
	R283	QRD167J-102	1K	1/6W	CARBON	
	R284	QRD167J-102	1K	1/6W	CARBON	
	R285	QRD167J-103	10K	1/6W	CARBON	
	R286	QRD167J-103	10K	1/6W	CARBON	
	R287	QRD167J-102	1K	1/6W	CARBON	
	R288	QRD167J-102	1K	1/6W	CARBON	
	R291	QRD167J-103	10K	1/6W	CARBON	
	R292	QRD167J-103	10K	1/6W	CARBON	
	R298	QRD167J-124	120K	1/6W	CARBON	
	R300	QRD167J-391	390	1/6W	CARBON	
	R301	QRD167J-271	270	1/6W	CARBON	
	R302	QRD167J-271	270	1/6W	CARBON	
	R303	QRD167J-271	270	1/6W	CARBON	
	R304	QRD167J-271	270	1/6W	CARBON	
	R305	QRD167J-561	560	1/6W	CARBON	
	R309	QRD167J-473	47K	1/6W	CARBON	
	R310	QRD167J-473	47K	1/6W	CARBON	
	R311	QRD167J-103	10K	1/6W	CARBON	
	R312	QRD167J-103	10K	1/6W	CARBON	
	R313	QRD167J-153	15K	1/6W	CARBON	
	R314	QRD167J-153	15K	1/6W	CARBON	
	R315	QRD167J-103	10K	1/6W	CARBON	
	R316	QRD167J-103	10K	1/6W	CARBON	
	R317	QRD167J-223	22K	1/6W	CARBON	
	R318	QRD167J-223	22K	1/6W	CARBON	
	R319	QRD167J-823	82K	1/6W	CARBON	
	R320	QRD167J-823	82K	1/6W	CARBON	
	R321	QRZ0077-220	22	1/4W	FUSIBLE	
	R322	QRD167J-124	120K	1/6W	CARBON	
	R323	QRD167J-475	4.7M	1/6W	CARBON	

Δ : SAFETY PARTS

Note (1)

PC Board Ass'y	Designated Areas
ENJ-050 A	Canada, the U.S.A.
ENJ-050 B	Australia, the U.K., Continental Europe, Universal Type
ENJ-050 C	Germany, Italy

Transistors

ITEM	PART NUMBER	DESCRIPTION	AREA
Q258	DTC144ES	SILICON ROHM	
Q259	DTC144ES	SILICON ROHM	
Q260	DTC144ES	SILICON ROHM	
Q274	2SD2144S(VW)	SILICON ROHM	
Q281	2SK301(P,Q)	F.E.T. MATSUSHITA	
Q282	2SK301(P,Q)	F.E.T. MATSUSHITA	
Q305	2SD2144S(VW)	SILICON ROHM	
Q306	2SD2144S(VW)	SILICON ROHM	
Q307	2SD2144S(VW)	SILICON ROHM	
Q308	2SD2144S(VW)	SILICON ROHM	
Q331	2SC1740S(R,S)	SILICON ROHM	
Q332	2SC1740S(R,S)	SILICON ROHM	
Q333	2SC1740S(R,S)	SILICON ROHM	
Q335	DTC144ES	SILICON ROHM	
Q336	DTC144ES	SILICON ROHM	
Q337	DTC144ES	SILICON ROHM	
Q338	DTC144ES	SILICON ROHM	
Q339	2SC1685(Q,R)	SILICON MATSUSHITA	
Q340	2SC1685(Q,R)	SILICON MATSUSHITA	
Q351	2SC1740S(R,S)	SILICON ROHM	
Q352	2SC1740S(R,S)	SILICON ROHM	
Q353	2SC1740S(R,S)	SILICON ROHM	
Q354	2SC1740S(R,S)	SILICON ROHM	
Q355	2SC1740S(R,S)	SILICON ROHM	
Q356	2SC1740S(R,S)	SILICON ROHM	
Q357	2SC1740S(R,S)	SILICON ROHM	
Q361	DTC144ES	SILICON ROHM	
Q365	DTC144EFF	SILICON ROHM	
Q366	DTC144ES	SILICON ROHM	
Q371	2SD2144S(VW)	SILICON ROHM	
Q372	2SD2144S(VW)	SILICON ROHM	
Q373	2SD2144S(VW)	SILICON ROHM	
Q374	2SD2144S(VW)	SILICON ROHM	
Q375	DTC144ES	SILICON ROHM	
Q391	2SD2144S(VW)	SILICON ROHM	
Q392	2SD2144S(VW)	SILICON ROHM	
Q395	DTA144ES	SILICON ROHM	
Q405	DTC144TS	SILICON ROHM	
Q406	DTC144TS	SILICON ROHM	
Q407	DTC144TS	SILICON ROHM	
Q408	DTC144TS	SILICON ROHM	
Q409	DTC144TS	SILICON ROHM	
Q410	DTC144TS	SILICON ROHM	
Q411	DTC144TS	SILICON ROHM	
Q412	DTC144TS	SILICON ROHM	
Q431	2SA933S(R,S)	SILICON ROHM	
Q432	DTC114WS	SILICON SO01	
Q441	DTC144TS	SILICON ROHM	
Q442	DTC144TS	SILICON ROHM	
Q443	DTC144TS	SILICON ROHM	
Q444	DTC144TS	SILICON ROHM	
Q451	2SK301(P,Q)	F.E.T. MATSUSHITA	
Q452	2SK301(P,Q)	F.E.T. MATSUSHITA	
Q453	2SK301(P,Q)	F.E.T. MATSUSHITA	
Q454	2SK301(P,Q)	F.E.T. MATSUSHITA	
Q457	DTC144TS	SILICON ROHM	
Q458	DTC144TS	SILICON ROHM	
Q459	2SC1740S(R,S)	SILICON ROHM	
Q460	DTC114WS	SILICON SO01	
Q461	DTC144ES	SILICON ROHM	
Q462	DTC144ES	SILICON ROHM	
Q463	2SB544MP(E,F)	SILICON SANYO	
Q464	2SB544MP(E,F)	SILICON SANYO	
Q465	DTA114YS	SILICON ROHM	
Q478	2SD2037(E,F)	SILICON ROHM	
Q479	DTC114WS	SILICON SO01	
Q480	DTC144ES	SILICON ROHM	
Q481	DTC114WS	SILICON SO01	
Q483	2SA933S(R,S)	SILICON ROHM	
Q484	2SA933S(R,S)	SILICON ROHM	
Q485	DTA114TS	SILICON ROHM	
Q486	DTC114ES	SILICON ROHM	

△ : SAFETY PARTS

I.C.s

ITEM	PART NUMBER	DESCRIPTION	AREA
IC281	UPC1228HA	I.C. NEC	
IC331	UPC1330HA	I.C. NEC	
IC341	UPC1297CA	I.C. NEC	
IC351	HA12142NT	I.C. HITACHI	
IC361	BU4053B	I.C. ROHM	
IC371	BA15218N	I.C. ROHM	
IC401	BA15218N	I.C. ROHM	
IC451	BA6218	I.C. ROHM	
IC452	BA6218	I.C. ROHM	
IC453	LB1639-CV	I.C. SANYO	
IC454	LB1639-CV	I.C. SANYO	
IC461	UPC1228HA	I.C. NEC	
IC491	HD614081SC43	I.C. HITACHI	

△ : SAFETY PARTS

Diodes

ITEM	PART NUMBER	DESCRIPTION	AREA
D260	1SS133	SILICON ROHM	
D275	1SS133	SILICON ROHM	
D276	MTZ4.7JB	ZENER ROHM	
D300	SLH-34VC3F	L.E.D. ROHM	
D301	SLH-34MC3F	L.E.D. ROHM	
D302	SLH-34MC3F	L.E.D. ROHM	
D303	SLH-34MC3F	L.E.D. ROHM	
D304	SLH-34MC3F	L.E.D. ROHM	
D305	SLH-34VC3F	L.E.D. ROHM	
D331	1SS133	SILICON ROHM	
D332	1SS133	SILICON ROHM	
D333	1SS133	SILICON ROHM	
D340	1SS133	SILICON ROHM	
D451	1SR139-200	SILICON ROHM	
D452	1SR139-200	SILICON ROHM	
D453	1SR139-200	SILICON ROHM	
D454	1SR139-200	SILICON ROHM	
D458	1SS133	SILICON ROHM	
D461	1SS133	SILICON ROHM	
D462	1SS133	SILICON ROHM	
D463	1SS133	SILICON ROHM	
D464	1SS133	SILICON ROHM	
D465	1SS133	SILICON ROHM	
D467	1SS133	SILICON ROHM	
D468	1SS133	SILICON ROHM	
D469	1SS133	SILICON ROHM	
D474	1SS133	SILICON ROHM	
D475	1SS133	SILICON ROHM	
D478	MTZ6.2JC	ZENER ROHM	
D479	1SR139-200	SILICON ROHM	
D480	1SR139-200	SILICON ROHM	
D481	1SR139-200	SILICON ROHM	
D485	MTZ3.9JB	ZENER ROHM	
D491	1SS133	SILICON ROHM	
D494	1SS133	SILICON ROHM	

△ : SAFETY PARTS

Capacitors

ITEM	PART NUMBER	DESCRIPTION	AREA
C260	GETB1CM-226	22MF 16V ELECTRO	
C281	GETB1HM-225	2.2MF 50V ELECTRO	
C282	GETB1HM-225	2.2MF 50V ELECTRO	
C283	QCS21HJ-101	100PF 50V CERAMIC	
C284	QCS21HJ-101	100PF 50V CERAMIC	
C285	GETB1AM-107	100MF 10V ELECTRO	
C286	GETB1AM-107	100MF 10V ELECTRO	
C287	QFLB1HJ-822	8200PF 50V MYLAR	
C288	QFLB1HJ-822	8200PF 50V MYLAR	
C289	GETB1HM-105	1MF 50V ELECTRO	
C290	GETB1HM-105	1MF 50V ELECTRO	
C291	QKS1CM-107	100MF 16V ELECTRO	
C301	QCY21HK-122	1200PF 50V CERAMIC	
C302	QCY21HK-122	1200PF 50V CERAMIC	
C303	GETB1HM-105	1MF 50V ELECTRO	
C304	QFV81HJ-223	0.022MF 50V T.FILM	
C317	QFLB1HJ-222	2200PF 50V MYLAR	
C318	QFLB1HJ-222	2200PF 50V MYLAR	
C320	QGBB1HK-471	470PF 50V CERAMIC	
C322	QGBB1HK-102	1000PF 50V CERAMIC	
C325	QFLB1HJ-222	2200PF 50V MYLAR	
C326	QFLB1HJ-222	2200PF 50V MYLAR	
C327	QFLB1HJ-682	6800PF 50V MYLAR	
C328	QFV81HJ-153	0.015MF 50V T.FILM	
C329	QFP81HG-562	5600PF 50V POLY	
C331	GETB1HM-105	1MF 50V ELECTRO	
C332	GETB1HM-105	1MF 50V ELECTRO	
C333	GETB1EM-106	10MF 25V ELECTRO	
C337	QCS21HJ-101	100PF 50V CERAMIC	
C338	QCS21HJ-101	100PF 50V CERAMIC	

△ : SAFETY PARTS

Others

ITEM	PART NUMBER	DESCRIPTION	AREA
J311	EMW10011-202	PRINTED BOARD	
J495	EMV7130-015	CONNECTOR(15PIN)	
J496	EMV7122-005	CONNECTOR(5PIN)	
L300	EMV7122-004	CONNECTOR(4PIN)	
L301	EQL4004-101	INDUCTOR	C
L306	EQL4004-100	INDUCTOR	C
L331	ENZ6002-011	OSCILLATOR COIL	
L333	EQL2106-223	INDUCTOR	
L334	EQL2106-223	INDUCTOR	
L341	ENZ2500-001	SPACER	
L342	ENZ2500-001	SPACER	
L401	EQL2106-562	INDUCTOR	
L402	EQL2106-562	INDUCTOR	
P331	QMV5011-007K	PLUG ASSY(7PIN)	
P333	QMV5011-003K	PLUG ASSY(3PIN)	
P490	EMV5109-003A	PLUG ASSY(3PIN)	
P491	EMV5109-005A	PLUG ASSY(5PIN)	
P492	EMV5109-005A	PLUG ASSY(5PIN)	
P493	EMV5109-004A	PLUG ASSY(4PIN)	
P494	EMV5109-003A	PLUG ASSY(3PIN)	
S300	ESP0001-018	TACT SWITCH(A REV PLAY)	
S301	ESP0001-018	TACT SWITCH(A REW)	
S302	ESP0001-018	TACT SWITCH(A F.FWD)	
S303	ESP0001-018	TACT SWITCH(A FWD PLAY)	
S310	ESP0001-018	TACT SWITCH(B REV PLAY)	
S311	ESP0001-018	TACT SWITCH(B REW)	
S312	ESP0001-018	TACT SWITCH(B F.FWD)	
S313	ESP0001-018	TACT SWITCH(B FWD PLAY)	
S320	ESP0001-018	TACT SWITCH(A STOP)	
S321	ESP0001-018	TACT SWITCH(B STOP)	
S322	ESP0001-018	TACT SWITCH(B REC)	
S323	ESP0001-018	TACT SWITCH(B PAUSE)	
S325	QSS6A12-E01	SLIDE SWITCH(BEAT CUT)	
S330	ESP0001-018	TACT SWITCH(N.DUBBING)	

△ : SAFETY PARTS

Others

ITEM	PART NUMBER	DESCRIPTION	AREA
S331	ESPO001-018	TACT SWITCH(BLANK SKIP)	
S333	ESPO001-018	TACT SWITCH(CD DIRECT)	
S340	QSS1A12-E02	SLIDE SWITCH(REV MODE)	
S350	QSS1A13-E03	SLIDE SWITCH(DOLBY B C NR)	
S461	ESB1100-003	LEAF SWITCH(FWD REC)	
S462	ESB1100-003	LEAF SWITCH(B MBAL)	
S463	ESB1100-003	LEAF SWITCH(B PACK)	
S464	ESB1100-003	LEAF SWITCH(B CrO2)	
S465	ESB1100-003	LEAF SWITCH(REV REC)	
S466	ESB1100-003	LEAF SWITCH(A CrO2)	
S467	ESB1100-005	LEAF SWITCH(A PACK)	
BC490	EWS253-A108	SOCKET WIRE(3PIN)	
BC491	EWS255-A108	SOCKET WIRE(5PIN)	
BC492	EWS255-A209	SOCKET WIRE(5PIN)	
BC493	EWS254-A009	SOCKET WIRE(4PIN)	
BC494	EWS253-A009	SOCKET WIRE(3PIN)	
EP301	E70859-001	EARTH PLATE	
FS301	EX0020005N10S	SPACER	
FS302	EX0020005N10S	SPACER	
FS303	EX0010005N10S	SPACER	
FS304	EX0010005N10S	SPACER	
FW460	EWR33B-25SST	FLAT WIRE(3PIN)	
FW489	EWR34B-25LST	FLAT WIRE(4PIN)	
FW495	EWR35B-30LST	FLAT WIRE(5PIN)	
FW496	EWR34B-25LST	FLAT WIRE(4PIN)	
FW497	EWR38B-35LST	FLAT WIRE(8PIN)	
FW498	EWR37B-20LST	FLAT WIRE(7PIN)	
FW499	EWR37B-25LST	FLAT WIRE(7PIN)	
JB311	EWP902-021	PLUG CORD ASSY(15PIN)	
XT491	ECX0004-194KM	RESONATOR	

△ : SAFETY PARTS

Resistors

Δ ITEM	PART NUMBER	DESCRIPTION	AREA
R324	QRD167J-103	10K 1/6W CARBON	
R325	QRD167J-104	100K 1/6W CARBON	
R326	QRD167J-475	4.7M 1/6W CARBON	
R327	QRD167J-563	56K 1/6W CARBON	
R328	QRD167J-563	56K 1/6W CARBON	
R331	QRD167J-332	3.3K 1/6W CARBON	
R332	QRD167J-332	3.3K 1/6W CARBON	
R333	QRD167J-104	100K 1/6W CARBON	
R334	QRD167J-621	620 1/6W CARBON	
R335	QRD167J-821	820 1/6W CARBON	
Δ R336	QRZ0077-100	10 1/4W FUSIBLE	
R337	QRD167J-471	470 1/6W CARBON	
R338	QRD167J-561	560 1/6W CARBON	
R339	QRD167J-563	56K 1/6W CARBON	
R340	QRD167J-563	56K 1/6W CARBON	
R341	QRD167J-100	10 1/6W CARBON	
R342	QRD167J-100	10 1/6W CARBON	
R343	QRD167J-222	2.2K 1/6W CARBON	
Δ R344	QRD14CJ-6R8S	6.8 1/4W UNF. CARBON	
R345	QRD167J-562	5.6K 1/6W CARBON	
R346	QRD167J-562	5.6K 1/6W CARBON	
R347	QRD167J-224	220K 1/6W CARBON	
R348	QRD167J-224	220K 1/6W CARBON	
R349	QRD167J-223	22K 1/6W CARBON	
R350	QRD167J-103	10K 1/6W CARBON	
R351	QRD167J-104	100K 1/6W CARBON	
R352	QRD167J-104	100K 1/6W CARBON	
R353	QRD167J-153	15K 1/6W CARBON	
R354	QRD167J-153	15K 1/6W CARBON	
R355	QRD167J-273	27K 1/6W CARBON	
R356	QRD167J-273	27K 1/6W CARBON	
R357	QRD167J-332	3.3K 1/6W CARBON	
R358	QRD167J-332	3.3K 1/6W CARBON	
R359	QRD167J-223	22K 1/6W CARBON	
R360	QRD167J-223	22K 1/6W CARBON	
R361	QRD167J-561	560 1/6W CARBON	
R362	QRD167J-561	560 1/6W CARBON	
R363	QRD167J-472	4.7K 1/6W CARBON	
R364	QRD167J-472	4.7K 1/6W CARBON	
R365	QRD167J-103	10K 1/6W CARBON	
R366	QRD167J-105	1M 1/6W CARBON	
R367	QRD167J-223	22K 1/6W CARBON	
R368	QRD167J-223	22K 1/6W CARBON	
R369	QRD167J-103	10K 1/6W CARBON	
R370	QRD167J-103	10K 1/6W CARBON	
R371	QRD167J-562	5.6K 1/6W CARBON	
R372	QRD167J-562	5.6K 1/6W CARBON	
R373	QRD167J-103	10K 1/6W CARBON	
R374	QRD167J-103	10K 1/6W CARBON	
R375	QRD167J-223	22K 1/6W CARBON	
R376	QRD167J-223	22K 1/6W CARBON	
R377	QRD167J-103	10K 1/6W CARBON	
R378	QRD167J-103	10K 1/6W CARBON	
R379	QRD167J-103	10K 1/6W CARBON	
R380	QRD167J-103	10K 1/6W CARBON	
R381	QRD167J-102	1K 1/6W CARBON	
R382	QRD167J-102	1K 1/6W CARBON	
R383	QRD167J-104	100K 1/6W CARBON	
R384	QRD167J-104	100K 1/6W CARBON	
R385	QRD167J-123	12K 1/6W CARBON	
R386	QRD167J-123	12K 1/6W CARBON	
R387	QRD167J-104	100K 1/6W CARBON	
R388	QRD167J-104	100K 1/6W CARBON	
R389	QRD167J-221	220 1/6W CARBON	
R390	QRD167J-221	220 1/6W CARBON	
Δ R391	QRD167J-562	5.6K 1/6W CARBON	
R392	QRD167J-562	5.6K 1/6W CARBON	
R393	QRZ0077-100	10 1/4W FUSIBLE	
R395	QRD167J-103	10K 1/6W CARBON	
R396	QRD167J-103	10K 1/6W CARBON	
R397	QRD167J-102	1K 1/6W CARBON	
R398	QRD167J-223	22K 1/6W CARBON	
R399	QRD167J-223	22K 1/6W CARBON	
R400	QRD167J-103	10K 1/6W CARBON	
R401	QRD167J-333	33K 1/6W CARBON	
R402	QRD167J-333	33K 1/6W CARBON	
R403	QRD167J-472	4.7K 1/6W CARBON	
R404	QRD167J-472	4.7K 1/6W CARBON	
R405	QRD167J-683	68K 1/6W CARBON	
R406	QRD167J-683	68K 1/6W CARBON	
R407	QRD167J-153	15K 1/6W CARBON	
R408	QRD167J-153	15K 1/6W CARBON	
R409	QRD167J-153	15K 1/6W CARBON	
R410	QRD167J-153	15K 1/6W CARBON	
R411	QRD167J-222	2.2K 1/6W CARBON	
R412	QRD167J-222	2.2K 1/6W CARBON	
R413	QRD167J-182	1.8K 1/6W CARBON	
R414	QRD167J-182	1.8K 1/6W CARBON	
R415	QRD167J-511	510 1/6W CARBON	
R416	QRD167J-511	510 1/6W CARBON	
R417	QRD167J-301	300 1/6W CARBON	
R418	QRD167J-301	300 1/6W CARBON	
R419	QRD167J-332	3.3K 1/6W CARBON	
R420	QRD167J-332	3.3K 1/6W CARBON	
R421	QRD167J-242	2.4K 1/6W CARBON	

Δ : SAFETY PARTS

Resistors

Δ ITEM	PART NUMBER	DESCRIPTION	AREA
R422	QRD167J-242	2.4K 1/6W CARBON	
R423	QRD167J-122	1.2K 1/6W CARBON	
R424	QRD167J-122	1.2K 1/6W CARBON	
R427	QRD167J-151	150 1/6W CARBON	
R428	QRD167J-151	150 1/6W CARBON	
R429	QRD167J-152	1.5K 1/6W CARBON	
R430	QRD167J-152	1.5K 1/6W CARBON	
R431	QRD167J-394	390K 1/6W CARBON	
R432	QRD167J-394	390K 1/6W CARBON	
R433	QRD167J-221	220 1/6W CARBON	
R434	QRD167J-392	3.9K 1/6W CARBON	
R435	QRD167J-154	150K 1/6W CARBON	
R436	QRD167J-154	150K 1/6W CARBON	
R437	QRD167J-183	18K 1/6W CARBON	
R438	QRD167J-183	18K 1/6W CARBON	
R440	QRD167J-221	220 1/6W CARBON	
R441	QRD167J-681	680 1/6W CARBON	
R442	QRD167J-681	680 1/6W CARBON	
R443	QRD167J-183	18K 1/6W CARBON	
R444	QRD167J-221	220 1/6W CARBON	
R445	QRD167J-221	220 1/6W CARBON	
R446	QRD167J-221	220 1/6W CARBON	
R447	QRD167J-103	10K 1/6W CARBON	
R448	QRD167J-103	10K 1/6W CARBON	
R449	QRD167J-103	10K 1/6W CARBON	
R451	QRD167J-822	8.2K 1/6W CARBON	
R452	QRD167J-512	5.1K 1/6W CARBON	
R453	QRD167J-470	47 1/6W CARBON	
R454	QRD167J-470	47 1/6W CARBON	
R455	QRD167J-334	330K 1/6W CARBON	
R456	QRD167J-334	330K 1/6W CARBON	
R457	QRD167J-432	4.3K 1/6W CARBON	
R458	QRD167J-432	4.3K 1/6W CARBON	
R459	QRD167J-392	3.9K 1/6W CARBON	
R460	QRD167J-392	3.9K 1/6W CARBON	
R461	QRD167J-682	6.8K 1/6W CARBON	
R462	QRD167J-682	6.8K 1/6W CARBON	
R463	QRD167J-752	7.5K 1/6W CARBON	
R464	QRD167J-752	7.5K 1/6W CARBON	
R465	QRD167J-223	22K 1/6W CARBON	
R466	QRD167J-223	22K 1/6W CARBON	
R467	QRD167J-105	1M 1/6W CARBON	
R468	QRD167J-105	1M 1/6W CARBON	
R469	QRD167J-105	1M 1/6W CARBON	
R470	QRD167J-105	1M 1/6W CARBON	
R471	QRD167J-471	470 1/6W CARBON	
R472	QRD167J-472	4.7K 1/6W CARBON	
R473	QRD167J-472	4.7K 1/6W CARBON	
R474	QRD167J-274	270K 1/6W CARBON	
R475	QRD167J-104	100K 1/6W CARBON	
R476	QRD167J-224	220K 1/6W CARBON	
R477	QRD167J-224	220K 1/6W CARBON	
R478	QRD167J-102	1K 1/6W CARBON	
R479	QRD167J-562	5.6K 1/6W CARBON	
R480	QRD167J-392	3.9K 1/6W CARBON	
R481	QRD167J-183	18K 1/6W CARBON	
R482	QRD167J-153	15K 1/6W CARBON	
R483	QRD167J-224	220K 1/6W CARBON	
R484	QRD167J-224	220K 1/6W CARBON	
R485	QRD167J-683	68K 1/6W CARBON	
R486	QRD167J-224	220K 1/6W CARBON	
R487	QRD167J-224	220K 1/6W CARBON	
R489	QRD167J-103	10K 1/6W CARBON	
R490	QRD167J-103	10K 1/6W CARBON	
R491	QRD167J-105	1M 1/6W CARBON	
R492	QRD167J-153	15K 1/6W CARBON	
R493	QRD167J-102	1K 1/6W CARBON	
R494	QRD167J-222	2.2K 1/6W CARBON	
R495	QRD167J-103	10K 1/6W CARBON	
R496	QRD167J-103	10K 1/6W CARBON	
R497	QRD167J-102	1K 1/6W CARBON	
R498	QRD167J-102	1K 1/6W CARBON	
R499	QRD167J-472	4.7K 1/6W CARBON	
R500	QRD167J-223	22K 1/6W CARBON	
RA491	QRB049J-103	10K 1/10W R.NETWORK	
RA492	QRB089J-103	10K 1/10W R.NETWORK	
RA495	QRB079J-103	10K 1/10W R.NETWORK	
VR281	QVPA601-201A	200 VARIABLE	
VR282	QVPA601-201A	200 VARIABLE	
VR311	QVPA601-503A	50K VARIABLE	
VR312	QVPA601-503A	50K VARIABLE	
VR341	QVPA601-203A	20K VARIABLE	
VR342	QVPA601-203A	20K VARIABLE	
VR451	QVPA601-201A	200 VARIABLE	
VR452	QVPA601-201A	200 VARIABLE	
VR461	QVPA601-103A	10K VARIABLE	
VR462	QVPA601-103A	10K VARIABLE	
VR463	QVPA601-103A	10K VARIABLE	
VR464	QVPA601-103A	10K VARIABLE	
VR481	QVPA601-203A	20K VARIABLE	
VR482	QVPA601-103A	10K VARIABLE	

Δ : SAFETY PARTS

Safety Precautions

1. The design of this product contains special hardware and many circuits and components specially for safety purposes. For continued protection, no changes should be made to the original design unless authorized in writing by the manufacturer. Replacement parts must be identical to those used in the original circuits. Services should be performed by qualified personnel only.
2. Alterations of the design or circuitry of the product should not be made. Any design alterations of the product should not be made. Any design alterations or additions will void the manufacturer's warranty and will further relieve the manufacture of responsibility for personal injury or property damage resulting therefrom.
3. Many electrical and mechanical parts in the products have special safety-related characteristics. These characteristics are often not evident from visual inspection nor can the protection afforded by them necessarily be obtained by using replacement components rated for higher voltage, wattage, etc. Replacement parts which have these special safety characteristics are identified in the Parts List of Service Manual. Electrical components having such features are identified by shading on the schematics and by (Δ) on the Parts List in the Service Manual. The use of a substitute replacement which does not have the same safety characteristics as the recommended replacement parts shown in the Parts List of Service Manual may create shock, fire, or other hazards.
4. The leads in the products are routed and dressed with ties, clamps, tubings, barriers and the like to be separated from live parts, high temperature parts, moving parts and/or sharp edges for the prevention of electric shock and fire hazard. When service is required, the original lead routing and dress should be observed, and it should be confirmed that they have been returned to normal, after re-assembling.
5. Leakage current check (Electrical shock hazard testing)
After re-assembling the product, always perform an isolation check on the exposed metal parts of the product (antenna terminals, knobs, metal cabinet, screw heads, headphone jack, control shafts, etc.) to be sure the product is safe to operate without danger of electrical shock.
Do not use a line isolation transformer during this check.

- Plug the AC line cord directly into the AC outlet. Using a "Leakage Current Tester", measure the leakage current from each exposed metal parts of the cabinet, particularly any exposed metal part having a return path to the chassis, to a known good earth ground. Any leakage current must not exceed 0.5mA AC (r.m.s.).

- Alternate check method

Plug the AC line cord directly into the AC outlet. Use an AC voltmeter having, 1,000 ohms per volt or more sensitivity in the following manner. Connect a 1,500 Ω 10 W resistor paralleled by a 0.15 μ F AC-type capacitor between an exposed metal part and a known good earth ground.

Measure the AC voltage across the resistor with the AC voltmeter.

Move the resistor connection to each exposed metal part, particularly any exposed metal part having a return path to the chassis, and measure the AC voltage across the resistor.

Now, reverse the plug in the AC outlet and repeat each measurement. Any voltage measured must not exceed 0.75 V AC (r.m.s.). This corresponds to 0.5 mA AC (r.m.s.).

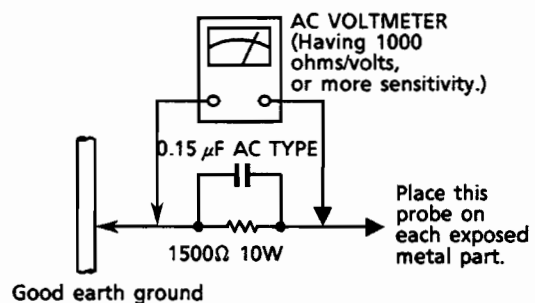

Warning

1. This equipment has been designed and manufactured to meet international safety standards.
2. It is the legal responsibility of the repairer to ensure that these safety standards are maintained.
3. Repairs must be made in accordance with the relevant safety standards.
4. It is essential that safety critical components are replaced by approved parts.
5. If mains voltage selector is provided, check setting for local voltage.

Specifications

FM TUNER SECTION

Tuning range : 87.5 MHz ~ 108.0 MHz
 Usable sensitivity : 0.95 μ V / 75 ohms(10.8 dBf)
 Signal-to-noise ratio : MONO (at 85dBf) 80 dB / 72dB
 (IHF-A Weighted / DIN) STEREO (at 85dBf) 73 dB / 64dB

AM TUNER SECTION

MW

Tuning range

Area	Channel space	
	9kHz	10kHz
U.S.A. Canada	—	530kHz~1710kHz
Continental Europe, U.K.	522kHz~1629kHz	—
Italy	522kHz~1629kHz	—
Australia	522kHz~1629kHz	—
Other Area	531kHz~1602kHz	530kHz~1600kHz

LW

Tuning range

Area	Channel Space (1kHz)
U.S.A. Canada	—
Continental Europe, U.K.	144kHz~353kHz
Italy	144kHz~290kHz
Australia	—
Other Area	—

GENERAL

Dimensions : 10-7/8" x 2-11/16" x 10-7/8" inches
 (W x H x D) (275 x 68 x 275 mm)
 Weight : 3.6 lbs. (1.6 kg)

Design and specifications subject to change without notice.

Description of Major LSIs

■ H614089SC35(IC201) : System Controller

1. Terminal Layout

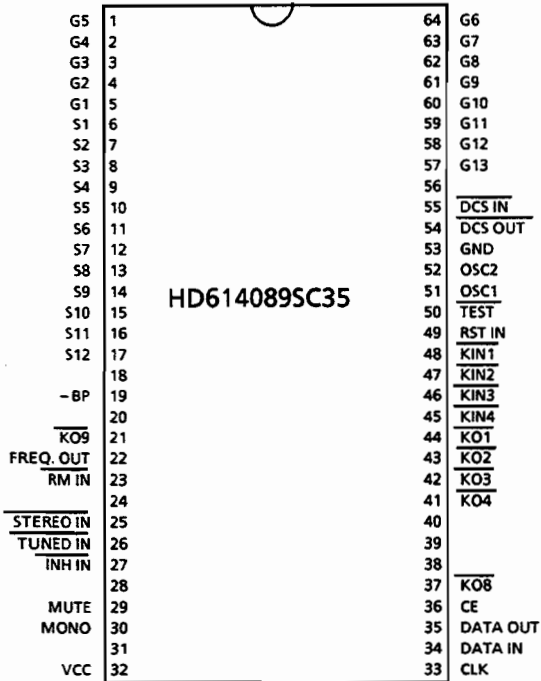

2. Key Matrix

	KEY OUT 1 (pin44)	KEY OUT2 (pin43)	KEY OUT3 (pin42)	KEY OUT4 (pin41)
KEY IN 1 (pin48)	TP203 (POWER)	WAKE-UP / SLEEP	UP	FM
KEY IN 2 (pin47)	TIMER1	CLOCK ADJ	DOWN	AM
KEY IN 3 (pin46)	TIMER2	CANCEL	PRESET UP	FM MODE/MUTE
KEY IN 4 (pin45)	DAILY	MEMORY	PRESET DOWN	-

3. Pin Functions

Pin NO.	symbol	I/O	Function and Operations	Pin NO.	symbol	I/O	Function and Operations
1	G5	O	FL grid control output	33	CLK	O	Clock output for data transmit
2	G4	O	∕	34	DAATA IN	I	Data input
3	G3	O	∕	35	DATA OUT	O	Data output
4	G2	O	∕	36	CE	O	Chip enable
5	G1	O	∕	37	KO8	O	Version setting signal
6	S1	O	FL segment control output	38	-	-	Non connection
7	S2	O	∕	39	-	-	∕
8	S3	O	∕	40	-	-	∕
9	S4	O	∕	41	KO4	O	Key matrix output
10	S5	O	∕	42	KO3	O	∕
11	S6	O	∕	43	KO2	O	∕
12	S7	O	∕	44	KO1	O	∕
13	S8	O	∕	45	KIN4	I	Key matrix input
14	S9	O	∕	46	KIN3	I	∕
15	S10	O	∕	47	KIN2	I	∕
16	S11	O	∕	48	KIN1	I	∕
17	S12	O	∕	49	RST IN	I	Reset signal input
18	-	-	Non connection	50	TEST	-	TEST terminal
19	-BP	I	Power supply for FL Display	51	osc1	I	Clock oscillation input
20	-	-	Non connection	52	osc2	O	Clock oscillation output
21	KO9	O	Key matrix output	53	GND	-	Ground
22	FREQ. OUT	O	Clock frequency output	54	DCS OUT	O	Compulink signal output
23	RM IN	I	Remote control signal input	55	DCS IN	I	Compulink signal input
24	-	-	Non connection	56	-	-	Non connection
25	STEREO IN	I	Input for indication of "STEREO"	57	G13	O	FL grid control output
26	TUNED IN	I	Input for indication of "TUNED"	58	G12	O	∕
27	INH IN	I	Inhibit signal input	59	G11	O	∕
28	-	-	Non connection	60	G10	O	∕
29	MUTE	O	Muting signal output	61	G9	O	∕
30	MONO	-	Non connection	62	G8	O	∕
31	-	-	∕	63	G7	O	∕
32	VCC	I	Power supply	64	G6	O	∕

■ LC7218 (IC102) : PLL Synthesizer

1. The main function descriptions

- (1) It makes the local oscillation frequency by the control data from IC201.
- (2) Decode the control signal and transmit the signal for receiving conditions.
- (3) For the best tuning, count the internal-frequency and transmit the data to IC201.

2. Terminal Layout

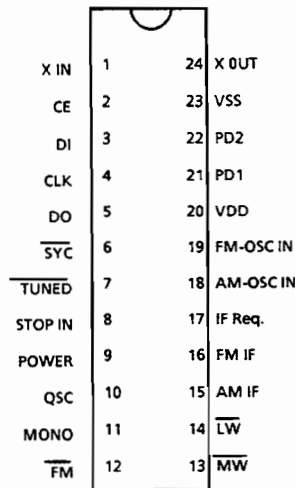

3. Block Diagram

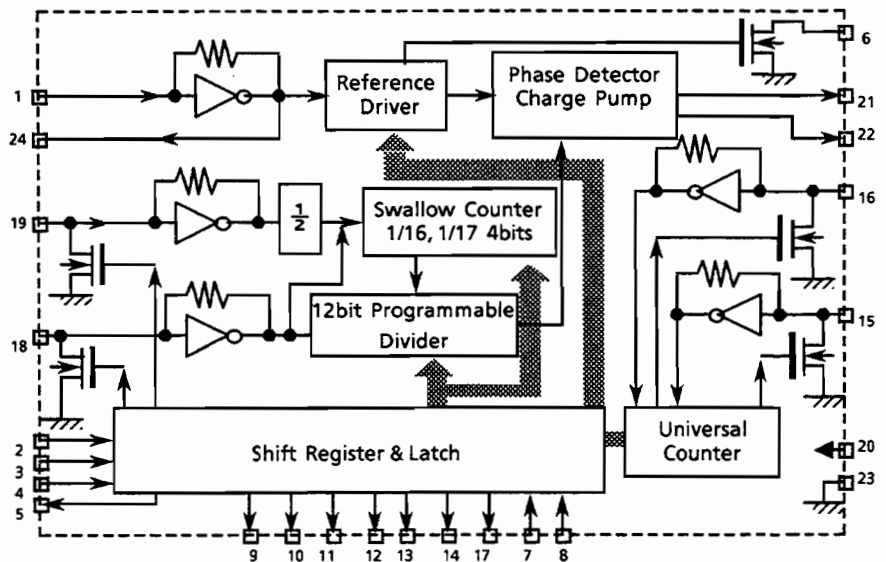

4. Pin Functions

Pin No.	Symbol	I/O	Functions and Operations
1,24	X in , X out	I/O	Crystal oscillator (7.2MHz).
2	CE	I	Fix the chip enable to "H" when inputting (DI) and outputting (DO) the serial data.
3	DI	I	Receive the control data from the controller (IC201).
4	CLK	I	This clock is used to synchronize data when transmitting the data of DI and DO.
5	DO	O	Transmit the data from LC7218 to the controller which is synchronized with CL.
6	SYC	—	Not used.
7	TUNED	I	Receive the tuned signal from IC104 (LA1266A).
8	STOP IN	I	Not used.
9	POWER	O	Not used.
10	QSC	O	ON mode with "H" and OFF mode with "L". (NOT USED)
11	MONO	O	It is "H" on FM-monaural, "L" on FM-Stereo.
12	FM	O	It is "H" on FM mode.
13	MW	O	It is "H" on MW mode.
14	LW	O	It is "H" on LW mode.
15	AM-IF	I	Universal counter input for AM-IF from IC104 (LA1266A).
16	FM-IF	I	Universal counter input for FM-IF from IC104(LA1266A).
17	IF Req.	O	Output the "IF-signal request" to IC104 when the pin-7 (TUNED) go to "H".
18	AM OSC IN	I	Input the local oscillator signal of AM.
19	FM OSC IN	I	Input the local oscillator signal of FM.
20	VDD	—	This is a terminal of power supply.
21	PD1	O	PLL charge pump output : When the local oscillator signal frequency is higher than the reference frequency high level signals will output. When it is lower than the reference frequency, low level signals will output. When it is same as reference frequency signals, it will be floating.
22	PD2	O	Not used.
23	VSS	—	Power supply.

FX-MX70BK

■ LA1266A (IC104) : FM AM IF AMP & detector

1. The main function descriptions

- (1) Amplify and detect of FM IF frequencies.
- (2) It has local oscillator and mixer for AM, and amplify the AM-IF signal.

2. Terminal Layout

FM-IF	1	24	AM-OSC OUT
BYPASS	2	23	AM-OSC
BYPASS	3	22	V.REF
GND	4	21	AM-IN
FM-DET	5	20	AM-MIX
FM-DET	6	19	AM-AGC
V _{CC}	7	18	AM-IF
SIG	8	17	AM ADJ.
FM-AFC	9	16	FM ADJ.
FM-IF	10	15	AM OUT
AM-IF	11	14	NAR SM
FM-OUT	12	13	STRQ

3. Block Diagram

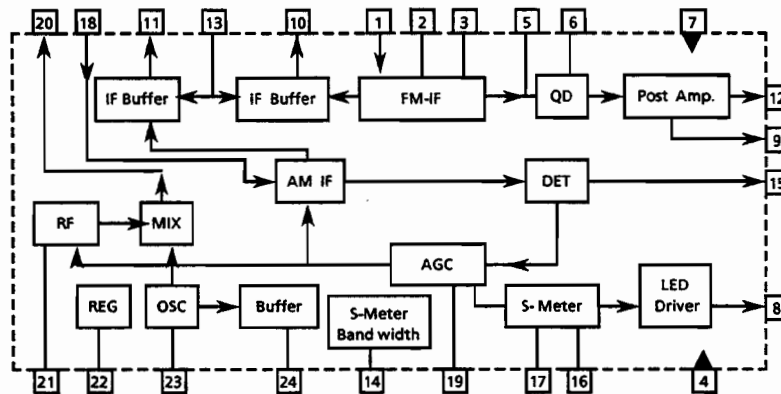

4. Pin Functions

Pin No.	Symbol	I/O	Functions and Operations
1	FM IF	I	This is an input terminal of FM IF Signal.
2,3	BYPASS	-	Bypass of FM IF Amp.
4	GND	-	This is the device ground terminal.
5,6	FM DET	-	FM detect transformer.
7	V _{CC}	-	This is the power supply terminal.
8	TUNED	O	When the set is tuning, this terminal become "L".
9	FM AFC	O	This is an output terminal of voltage for FM - AFC.
10	FM IF OUT	O	When the signal of IF REQ of IC102(LC7218) applied to pin17, the signal of FM IF does output.
11	AM IF OUT	O	When the signal of IF REQ of IC102(LC7218) applied to pin17, the signal of AM IF does output.
12	FM OUT	O	FM detection output.
13	STRQ	I	The IF-signals come out from pin10 (FM-IF) or pin11 (AM-IF) while this terminal going to "High".
14	NAR SM	-	Control the Band-width of signal meter.
15	AM OUT	O	AM detection output.
16	FM ADJ.	-	For adjust the stop level (or mute level) of FM.
17	AM ADJ.	-	For adjust the stop level (or mute level) of AM.
18	AM-IF	I	Input of AM IF Signal.
19	AM-AGC	I	This is an AGC voltage Input terminal for AM.
20	AM-MIX	O	This is an output terminal for AM mixer.
21	AM-IN	I	This is an input terminal for AM RF Signal.
22	V.REF	-	Register value between pin9 and pin22 desides the frequency width of the input signal.
23	AM-OSC	-	This is a terminal of AM Local oscillation circuit.
24	AM-OSC OUT	O	AM Local Oscillation Signal output.

■ LA3401 (IC105) : FM MPX Decoder

1. The main function descriptions

- (1) Decord the FM Multiplex Signal (Stereo signal).
- (2) When receiving FM Stereo Signal, it outputs the signal for indicator.
- (3) AM/FM Audio Amplifier.

2. Terminal Layout

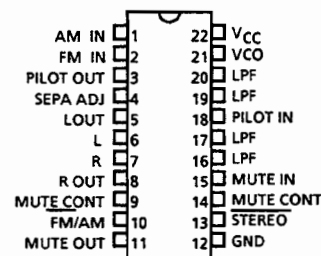

3. Block Diagram

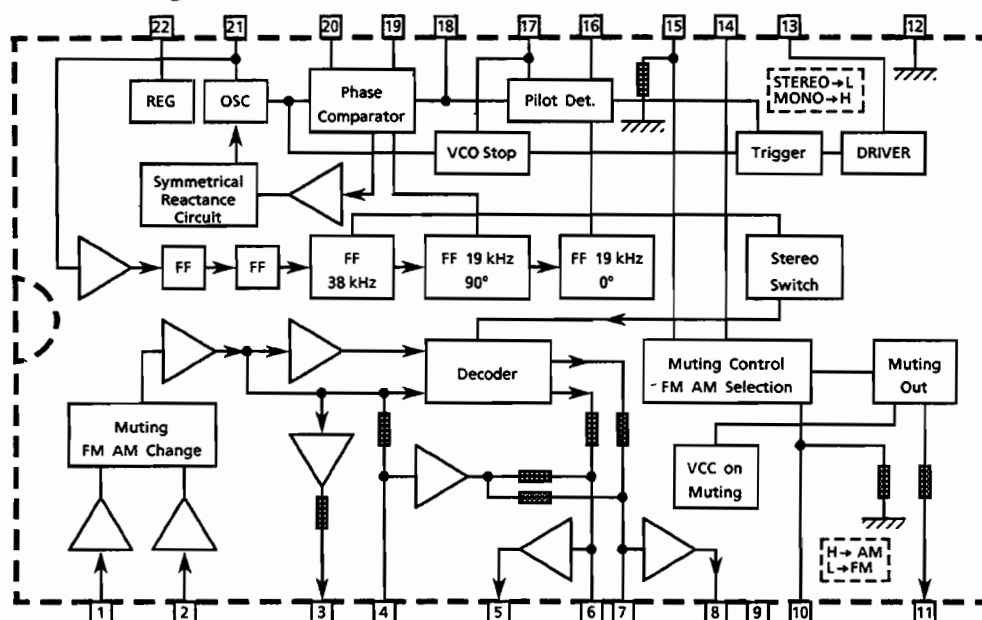

4. Pin Functions

Pin No.	Symbol	I/O	Functions and Operations
1	AM IN	I	This is an input terminal for AM detection signal.
2	FM IN	I	This is an input terminal for FM detection signal.
3	PILOT OUT	O	Output of MPX pilot signal (Connect to Pin18).
4	SEPA. ADJ.	-	Separation adjustment.
5	L. OUT	O	Left channel signal output.
6	L	O	Input terminal of the Left channel Post AMP.
7	R	O	Input terminal of the right channel Post AMP.
8	R OUT	O	Right channel signal output
9	MUTE CONT	-	The mute time is controlled by the connected capacitor when turning the power switch on.
10	FM/AM	I	Change over the FM/AM input. "H" : AM, "L" : FM
11	MUTE OUT	-	Not use
12	GND	-	Ground terminal.
13	STEREO	O	Stereo indicator output. Stereo : "L", Mono : "H"
14	MUTE CONT	-	The mute time is controlled by the connected capacitor when changing over the FN/ AM .
15	MUTE IN	I	Mute signal input. "H" : Mute on, "L" : Mute off.
16	LPF	-	Low pass filter of pilot detector.
17	LPF	-	While this terminal goes to "H", the VCO stop.
18	PILOT IN	I	PLL input.
19	LPF	-	Low-pass filter of PLL.
20	LPF	-	Low-pass filter of PLL.
21	VCO	I	Voltage controlled oscillator terminal.
22	V _{cc}	-	Power supply.

Internal Connections for the FL Display Tube

■ ELU0001-101:(FL201)

1. Grid Assignment

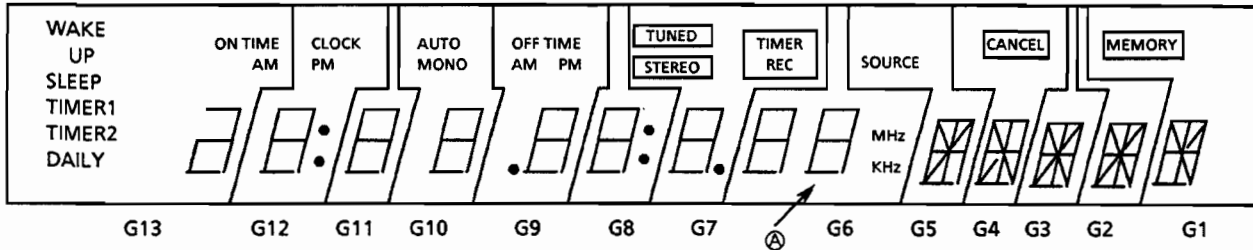

2. Pin Connections

PIN NO.	1	2	3	4	5	6	7	8	9	10	11	12	13	14	15	16	17	18	19	20	21	22	23
CONNECTION	FL1	FL1	NP	NC	G13	S1	S2	G13	S3	S4	G12	G12	S5	G11	S6	G10	S7	G9	G9	S8	S9	G8	S10
PIN NO.	24	25	26	27	28	29	30	31	32	33	34	35	36	37	38	39	40	41	42	43	44	45	46
CONNECTION	G7	S11	G6	S12	NC	NC	NC	G6	NC	G5	NC	G4	G4	NC	G3	NC	G2	NC	G1	NC	NP	F2	F2

[Note] F: Filament S: Segment G: Grid NP: No Pin NC: Non Connection

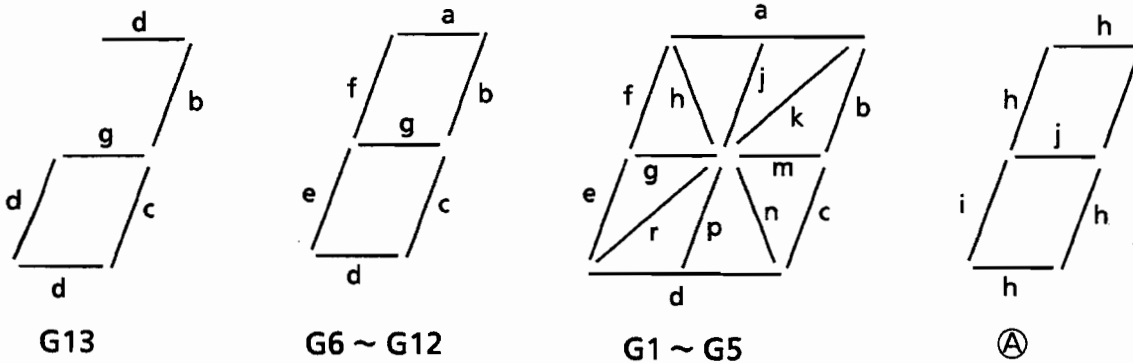

3. Anode Connections

	G13	G12	G11	G10	G9	G8	G7	G6	G5	G4	G3	G2	G1
S1	d	d	d	d	d	d	d	d	d	d	d	d	d
S2	—	e	e	e	e	e	e	e	e	e	e	e	e
S3	c	c	c	c	c	c	c	c	c	c	c	c	c
S4	g	—	—	—	—	—	—	kHz	r	r	r	r	m
S5	b	●	—	—	●	●	●	MHz	k	n	n	n	n
S6	DAILY	—	—	—	AM	—	STEREO	i	j,p	j,p	j,p	j,p	j,p
S7	TIMER2	g	g	g	g	g	g	g	g,m	g,m	g,m	g,m	g
S8	TIMER1	f	f	f	f	f	f	f	f	f	f	f	f
S9	SLEEP	b	b	b	b	b	b	b	b	b	b	b	b
S10	WAKE UP	a	a	a	a	a	a	a	a	a	a	a	a
S11	AM	PM	—	MONO	PM	—	TUNED	j	h	h	h	h	h,k
S12	ON TIME	CLOCK	—	AUTO	OFFTIME	—	TIMER REC	h	SOURCE	CANCEL	k	k	MEMORY

Disassembly Procedures

■ Removing the Top Cover

1. Remove the 4 screws (B) fastening the rear side of the Top cover, and 2 screws (A) fastening both sides.
2. Remove the Top Cover.

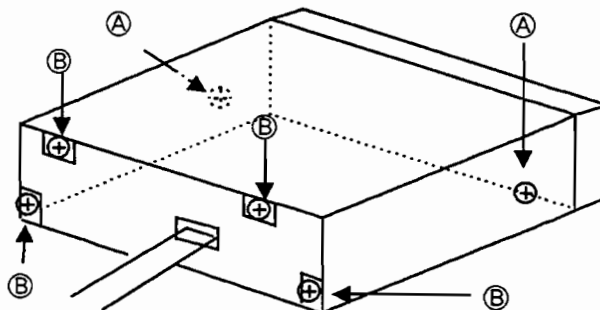

■ Removing the Front P.C.Board.

1. Remove the Top Cover.
2. Remove 4 screws (C) fastening the P.C.Board, and remove it.

■ Removing the Main P.C. Board

1. Remove the Top Cover.
2. Remove the 4 screws (D) fastening the P.C. Board.
3. Remove the screws (E) and remove the P.C.Board.

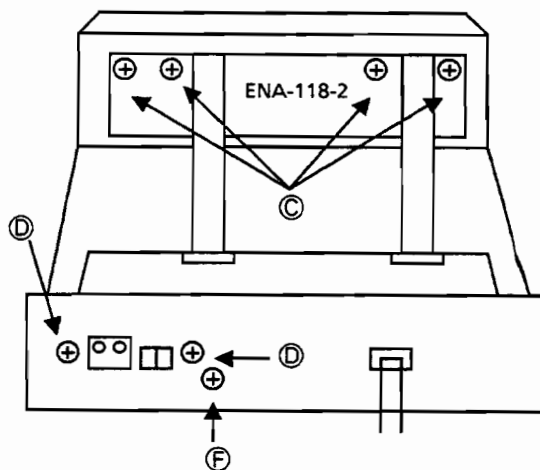
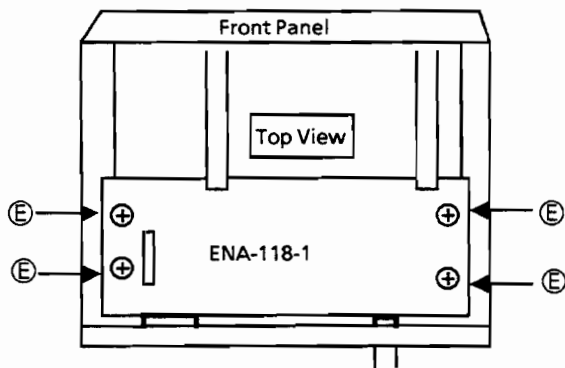

Connection Diagram

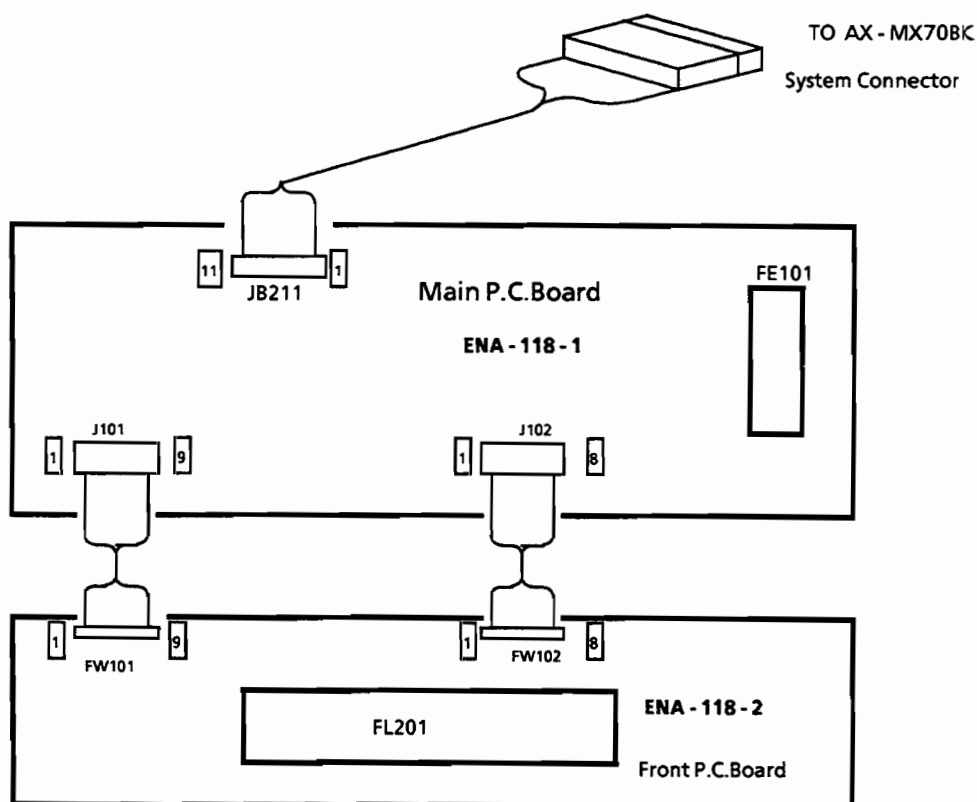

FM/AM Tuner Alignment Procedures

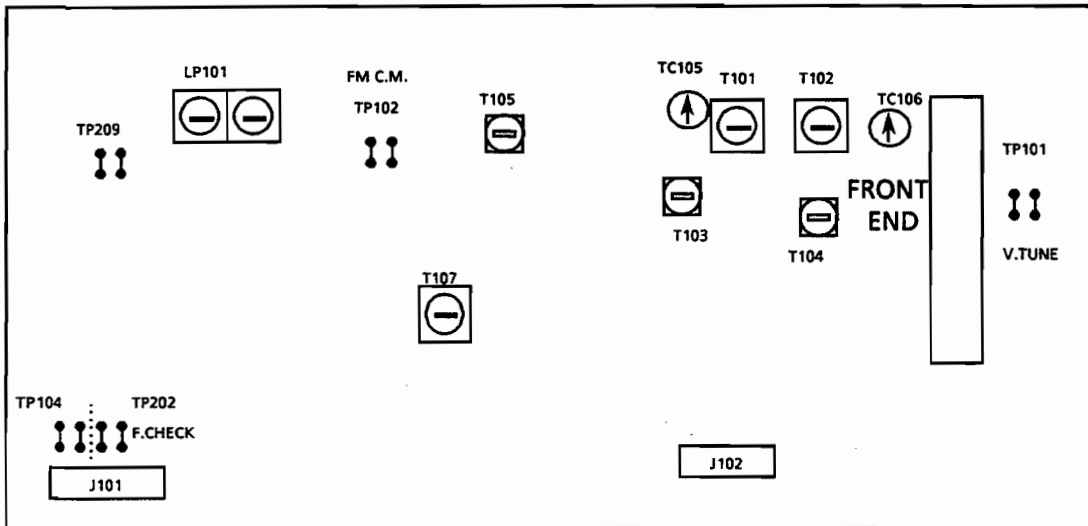

DISCHARGE

When discharging the backup, shortcircuit the two terminals of TP104.

1. FM section

FM oscillator

- (1) Set the frequency display to "108.0MHz".
- (2) Confirm that the FM inter-station noise is received.
- (3) Confirm that the voltage of test point "TP101" is $8.0V \pm 2.0V$.
- (4) Set the frequency display to "87.5MHz" and confirm the voltage of test point "TP101" is $1.6V \pm 1.0V$.

FM detector coil : T105

- (1) Connect a digital voltmeter to test point "TP102", and receive to "100.1MHz" signal with SSG at 70dB.
- (2) Adjust T105 so that the digital voltmeter reads $0 \pm 1.5mV$.

2. MW section

Note (): Australia, the U.K. and Continental Europe
 { }: Channel space 9kHz for universal version
 [] : Channel space 10kHz for universal version
 [] : America, Canada

MW oscillator : T103

- (1) Set the frequency display to (522kHz) {531kHz} [530kHz] [530kHz] and confirm that the voltage of test point TP101 is ($0.9V \pm 0.2V$) { $1.0V \pm 0.2V$ } [$1.0V \pm 0.2V$] [$1.0V \pm 0.2V$].
- (2) Set the frequency display to (1629kHz) {1602kHz} [1600kHz] [1710kHz] and confirm that the voltage of test point TP101 is ($7.5V \pm 0.8V$) { $7.2V \pm 0.7V$ } [$7.2V \pm 0.7V$] [$8.0V \pm 0.8V$].
- (3) If its voltage exceeds the allowance, adjust T103 to obtain the voltage.

MW antenna coil : T101

- (1) Connect a loop antenna to the "AM Loop" terminal on the rear panel.
- (2) Adjust T101 to obtain the best receiving sensitivity on 600kHz or 603kHz.

MW antenna trimmer : TC105

- (1) Adjust TC105 to obtain the best receiving sensitivity on 1400kHz or 1404kHz.

3. LW section (for Long Wave Version)

Note : [] for Italy

LW oscillator : T104

- (1) Set the frequency display to 144kHz and adjust T104 so that the voltage of TP101 becomes $0.8V \pm 0.1V$.
- (2) Set the frequency display to 353kHz [290kHz] and confirm that the voltage of test point TP101 becomes $8.0V \pm 0.9V$ [$5.7V \pm 0.6V$].

LW antenna coil : T102

- (1) Connect a loop antenna to the "AM Loop" terminal on the rear panel.
- (2) Adjust T102 to obtain the best receiving sensitivity on 164kHz [164kHz].

LW antenna trimmer : TC106

- (1) Adjust TC106 to obtain the best receiving sensitivity on 353kHz [245kHz].

※ Alternately adjust T102 and TC106 so that each sensitivity becomes maximum.

Clock Generator Frequency Adjustment

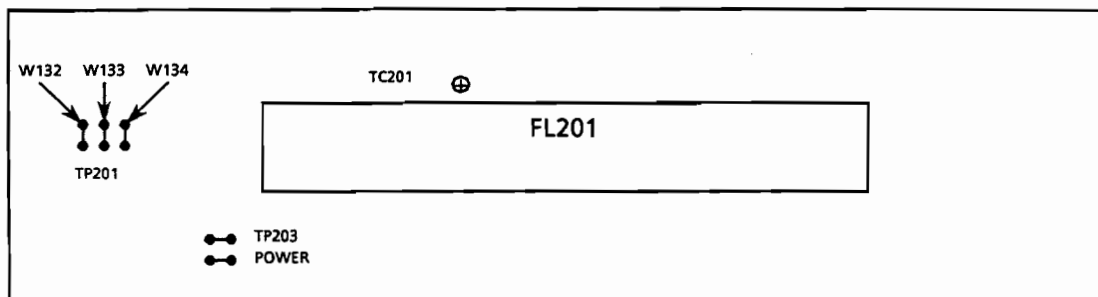

1. Switch OFF the AX-MX70BK's power source, then pull out the AC plug.
2. Shortcircuit TP201's terminals ② and ③ with the diode as shown in the accompanying diagram, then insert the AC plug into the receptacle to switch the power ON.
3. Confirm that the tuner's FL display is off, then remove the diode and connect the frequency counter to TP 202(FREQ. CHECK).
4. Adjust TC201 so that the counter becomes $34,952.5 \pm 0.15$ Hz.

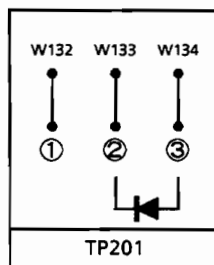

Example :
 1S5133
 1S5119
 1S2473

Schematic Diagrams

Tuner 1

FX-MX70BK (E,EF,G,BS,G1)

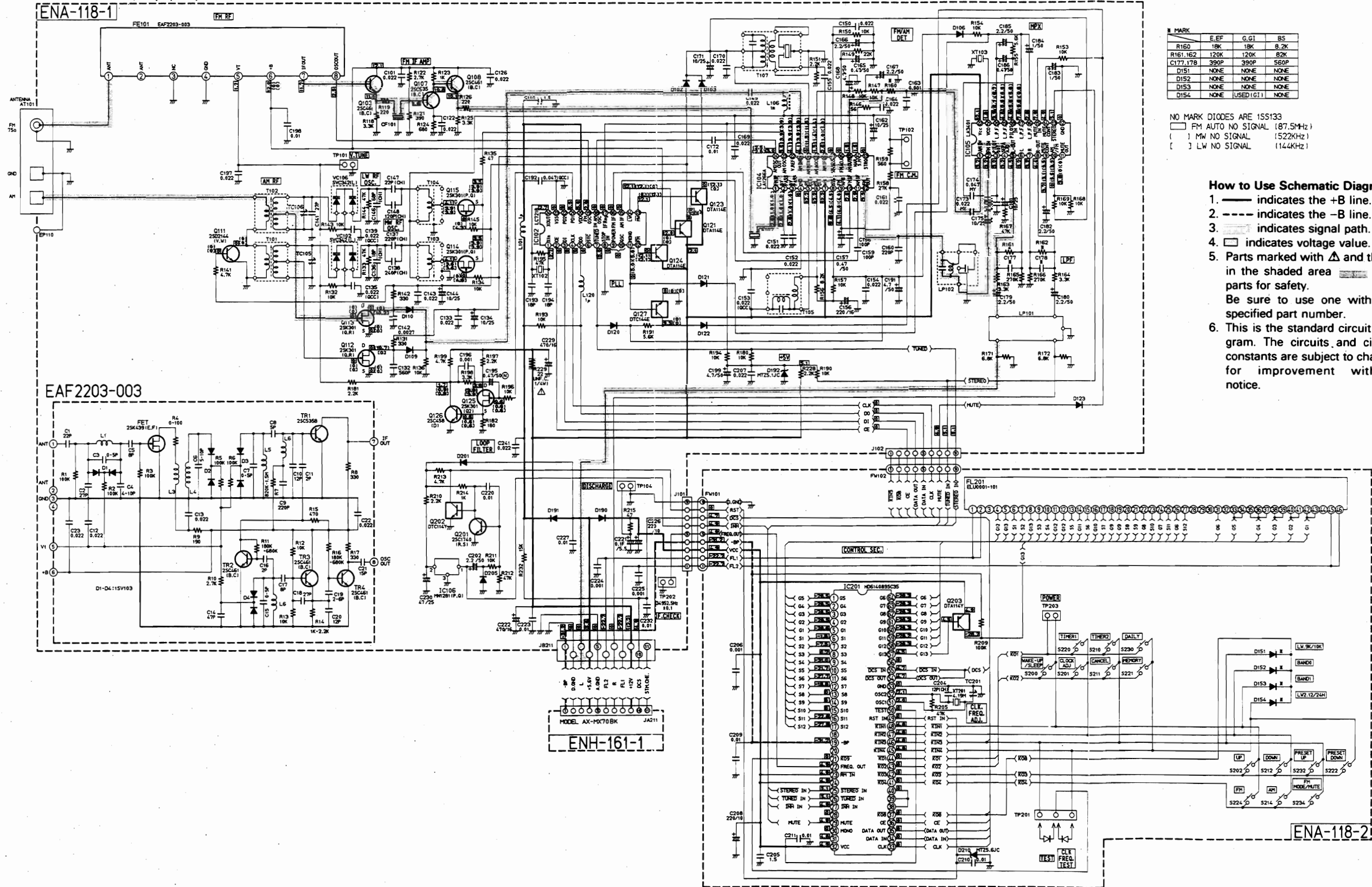

MARK	E,EF	G,G1	BS
R160	10K	10K	8.2K
R161,162	120K	120K	82K
C177,178	330P	330P	560P
D151	NONE	NONE	NONE
D152	NONE	NONE	NONE
D153	NONE	NONE	NONE
D154	NONE	USED (G1)	NONE

NO MARK DIODES ARE 1SS133
 □ FM AUTO NO SIGNAL (87.5MHz)
 () MW NO SIGNAL (522kHz)
 [] LW NO SIGNAL (114kHz)

How to Use Schematic Diagrams

1. — indicates the +B line.
2. - - - indicates the -B line.
3. — indicates signal path.
4. □ indicates voltage value.
5. Parts marked with Δ and those in the shaded area are parts for safety. Be sure to use one with the specified part number.
6. This is the standard circuit diagram. The circuits and circuit constants are subject to change for improvement without notice.

■ Tuner 2

FX-MX70BK (J,C,U,A)

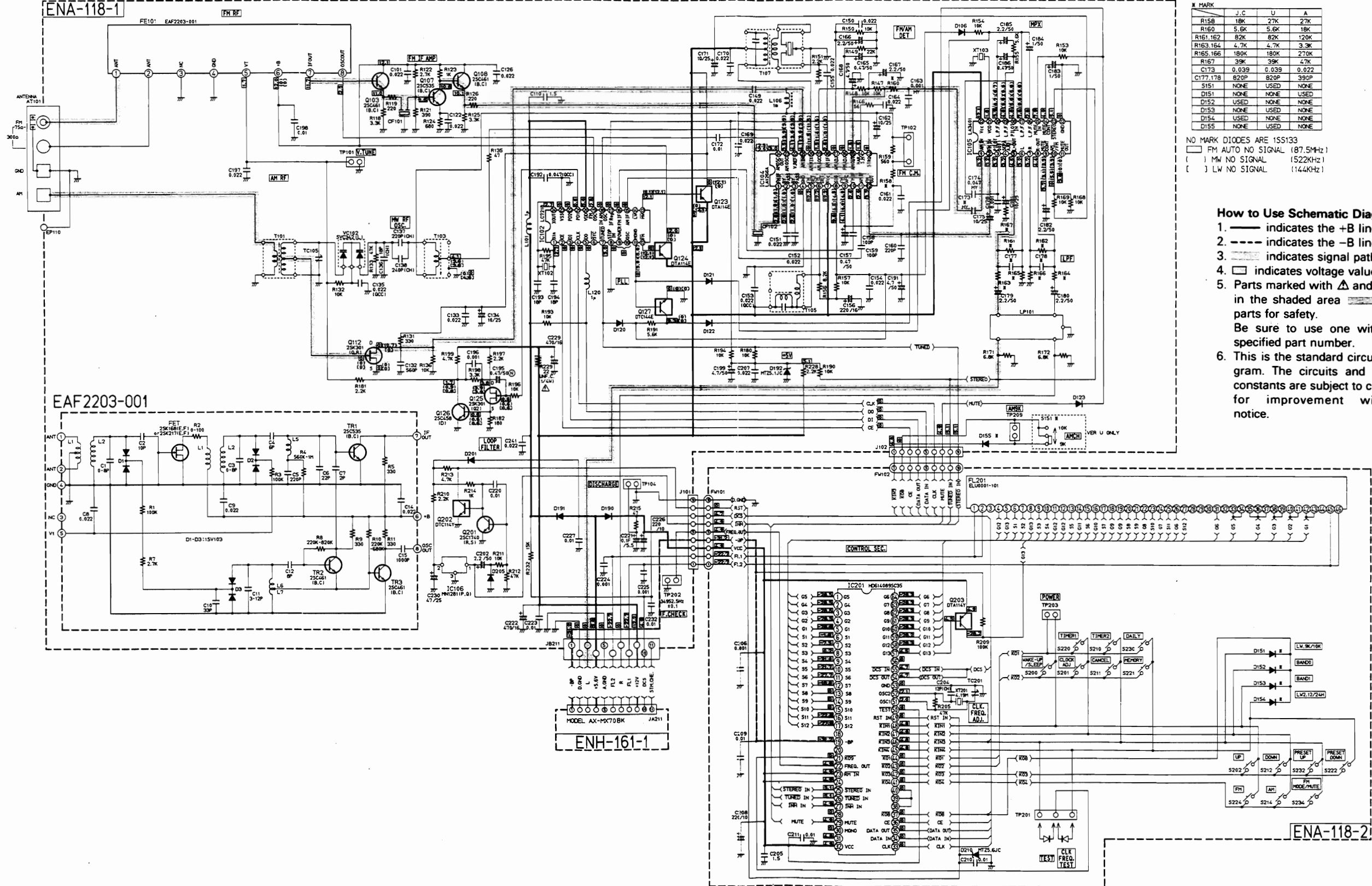

MARK	J.C	U	A
R158	18K	27K	27K
R160	5.6K	5.6K	18K
R161,162	82K	82K	120K
R163,164	4.7K	4.7K	3.3K
R165,166	180K	180K	270K
R167	39K	39K	4.7K
C173	0.039	0.039	0.022
C177,178	820P	820P	390P
S151	NONE	USED	NONE
D151	NONE	NONE	USED
D152	USED	NONE	NONE
D153	NONE	USED	NONE
D154	USED	NONE	NONE
D155	NONE	USED	NONE

NO MARK DIODES ARE 1SS133
 □ FM AUTO NO SIGNAL (187.5MHz)
 () MW NO SIGNAL (522KHz)
 [] LW NO SIGNAL (144KHz)

How to Use Schematic Diagrams

1. — indicates the +B line.
2. - - - indicates the -B line.
3. - - - indicates signal path.
4. □ indicates voltage value.
5. Parts marked with Δ and those in the shaded area are parts for safety. Be sure to use one with the specified part number.
6. This is the standard circuit diagram. The circuits and circuit constants are subject to change for improvement without notice.

Block Diagram

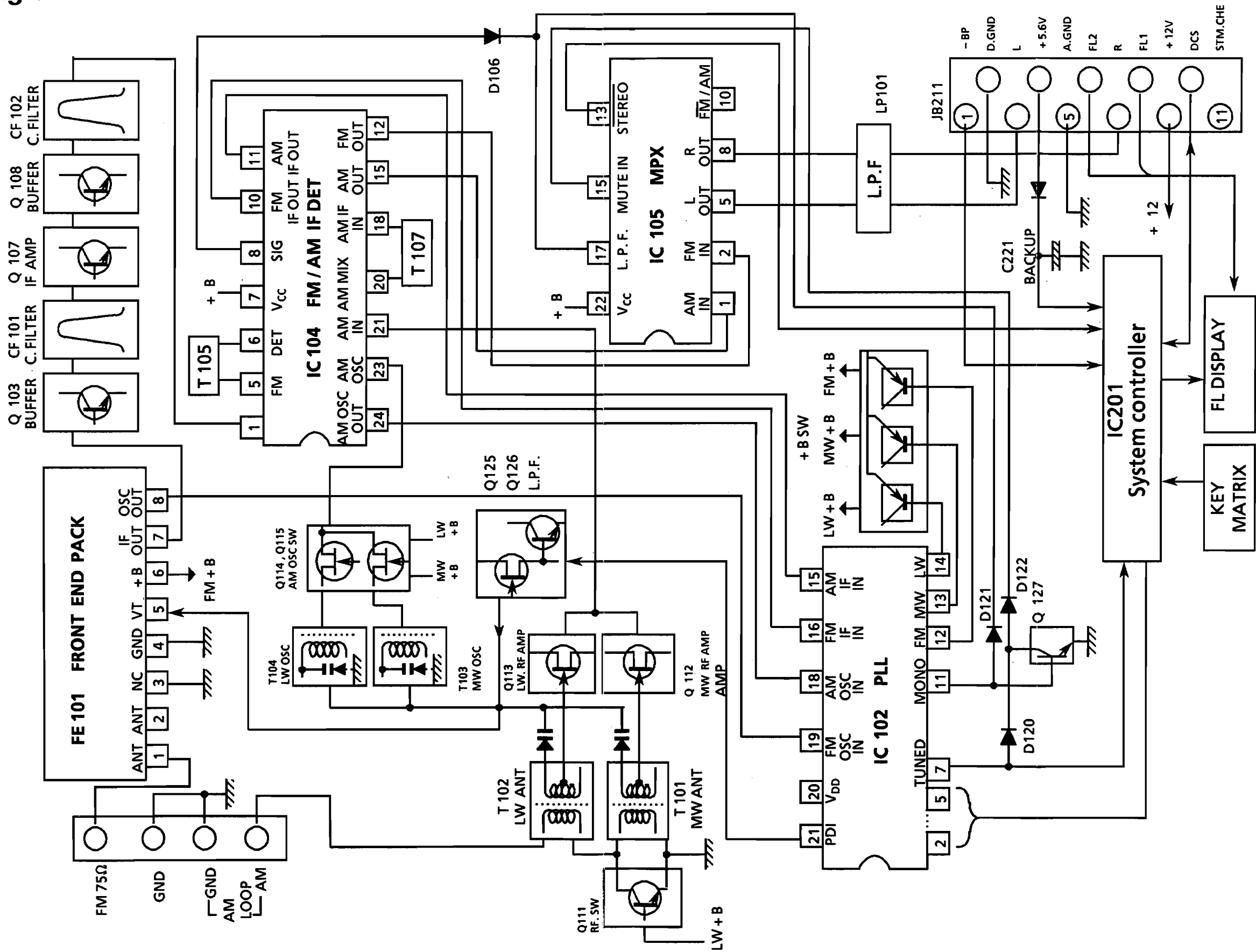

Printed Circuit Board

■ Tuner PCB (ENA118)

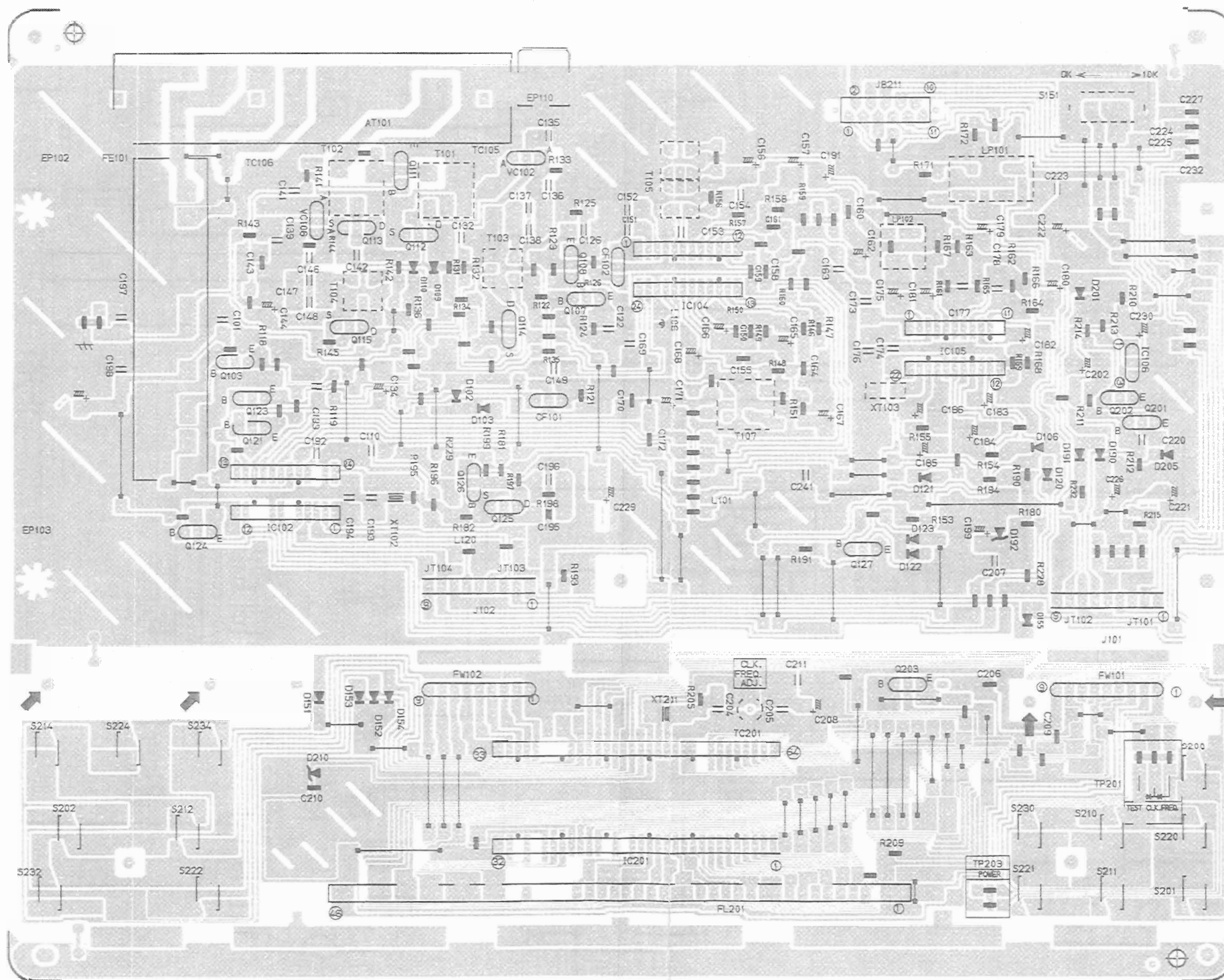

PARTS LIST

Contents

General Exploded View and Parts List	2-2
Printed Circuit Board Ass'y and Parts List	2-4
■ ENA-118 □ Tuner PC Board Ass'y	2-4
Packing Materials and Part Numbers	2-8

General Exploded View and Parts List

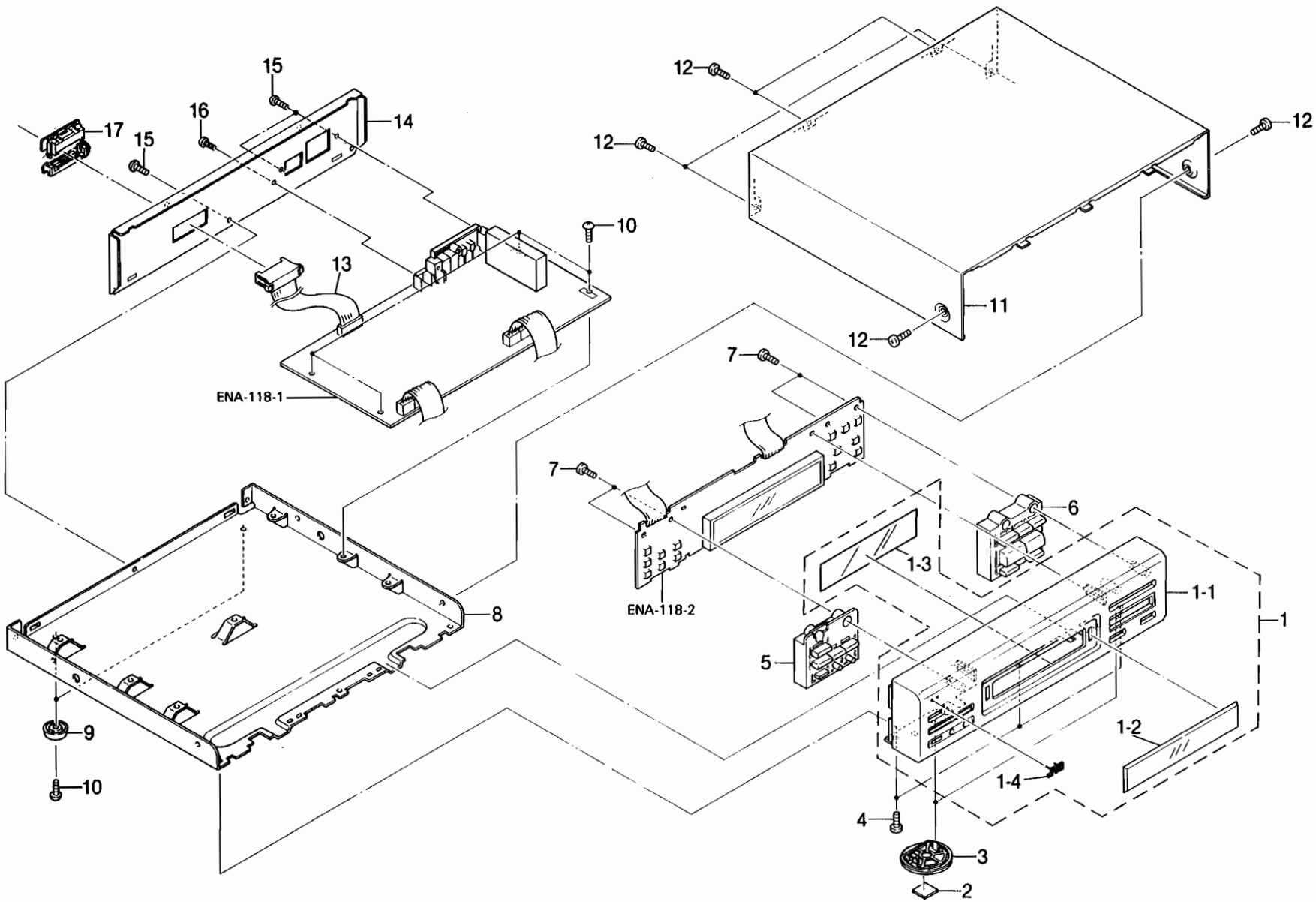

■ Parts List

⚠	Item	Part Number	Part Name	Q'ty	Description	Areas
	1	EFP-FXMX70BKE(S)	Front Panel Ass'y	1		
	1-1	E102331-003	Front Panel	1		
	1-2	E306956-002	Window Screen	1		
	1-3	E70561-028	FL Screen	1		
	1-4	PQ42561	JVC Mark	1		
	2	E75896-001	Spacer	2	for Front Foot	
	3	E306935-001	Foot	2	Front	
	4	SDSG3006M	Screw	3		
	5	E306952-001	Push Button	1	Tuning	
	6	E306954-002	Push Button	1	Preset	J, C, U, A
	7	E306954-003	Push Button	1	Preset	E, EF, G, GI, BS
	8	SDSF2608Z	Screw	4		
	8	E102327-002	Chassis Base	1		
	9	E47227-029	Foot	2	Rear	
	10	SBSG3008N	Screw	6		
	11	E206817-001	Metal Cover	1		
	12	SDSG3008M	Screw	6		
	13	EWP902-019	Plug Cord Ass'y	1	FW001(11Pin)	
	14	E206818-007	Rear Panel	1		J
		E206818-008	Rear Panel	1		C, A
		E206818-009	Rear Panel	1		U
		E206818-010	Rear Panel	1		E, EF, G, GI, BS
	15	SBSG3008M	Screw	3		
	16	SBST3008M	Screw	1		
	17	E305920-001	Cord Holder	1		
	—	E61029-009	Number Label	1		

⚠: Safety Parts

The Marks Designated Areas

J.....the U.S.A.
 C.....Canada
 A.....Australia
 G.....Germany
 GI.....Italy

BS.....the U.K.
 E, EF.....Continental Europe
 U.....Universal Type
 No mark indicates all areas.

Note (1)

PC Board Ass'y	Designated Areas
ENA-118 A	the U.S.A., Canada
ENA-118 B	Universal Type
ENA-118 C	Australia
ENA-118 D	Continental Europe
ENA-118 E	Germany
ENA-118 F	the U.K.
ENA-118 G	Italy

Transistors

ITEM	PART NUMBER	DESCRIPTION	AREA
Q103	2SC461(B,C)	SILICON HITACHI	
Q107	2SC535(B,C)	SILICON HITACHI	
Q108	2SC461(B,C)	SILICON HITACHI	
Q111	2SD2144S(VW)	SILICON ROHM	D
Q111	2SD2144S(VW)	SILICON ROHM	E
Q111	2SD2144S(VW)	SILICON ROHM	F
Q111	2SD2144S(VW)	SILICON ROHM	G
Q112	2SK301(Q,R)	F.E.T. MATSUSHITA	
Q113	2SK301(Q,R)	F.E.T. MATSUSHITA	D
Q113	2SK301(Q,R)	F.E.T. MATSUSHITA	E
Q113	2SK301(Q,R)	F.E.T. MATSUSHITA	F
Q113	2SK301(Q,R)	F.E.T. MATSUSHITA	G
Q114	2SK301(P,Q)	F.E.T. MATSUSHITA	D
Q114	2SK301(P,Q)	F.E.T. MATSUSHITA	E
Q114	2SK301(P,Q)	F.E.T. MATSUSHITA	F
Q114	2SK301(P,Q)	F.E.T. MATSUSHITA	G
Q115	2SK301(P,Q)	F.E.T. MATSUSHITA	D
Q115	2SK301(P,Q)	F.E.T. MATSUSHITA	E
Q115	2SK301(P,Q)	F.E.T. MATSUSHITA	F
Q115	2SK301(P,Q)	F.E.T. MATSUSHITA	G
Q121	DTA114ES	SILICON ROHM	D
Q121	DTA114ES	SILICON ROHM	E
Q121	DTA114ES	SILICON ROHM	F
Q121	DTA114ES	SILICON ROHM	G
Q123	DTA114ES	SILICON ROHM	D
Q124	DTA114ES	SILICON ROHM	E
Q125	2SK301(Q2)	F.E.T. MATSUSHITA	F
Q126	2SC458(D)	SILICON HITACHI	D
Q127	DTC144ES	SILICON ROHM	E
Q201	2SC1740S(R,S)	SILICON ROHM	F
Q202	DTC114YS	SILICON ROHM	G
Q203	DTA114YS	SILICON ROHM	D

△ : SAFETY PARTS

I.C.s

ITEM	PART NUMBER	DESCRIPTION	AREA
IC102	LC7218	I.C. SANYO	
IC104	LA1266A	I.C. SANYO	
IC105	LA3401	I.C. SANYO	
IC106	MM1281(P,Q)	I.C. MATSUSHITA	
IC201	HD614089SC35	I.C. HITACHI	

△ : SAFETY PARTS

Diodes

ITEM	PART NUMBER	DESCRIPTION	AREA
D102	1SS133	SILICON ROHM	D
D102	1SS133	SILICON ROHM	E
D102	1SS133	SILICON ROHM	F
D102	1SS133	SILICON ROHM	G
D103	1SS133	SILICON ROHM	D
D103	1SS133	SILICON ROHM	E
D103	1SS133	SILICON ROHM	F
D103	1SS133	SILICON ROHM	G
D106	1SS133	SILICON ROHM	
D109	1SS133	SILICON ROHM	D
D109	1SS133	SILICON ROHM	E
D109	1SS133	SILICON ROHM	F
D109	1SS133	SILICON ROHM	G
D110	1SS133	SILICON ROHM	D
D110	1SS133	SILICON ROHM	E
D110	1SS133	SILICON ROHM	F
D110	1SS133	SILICON ROHM	G
D120	1SS133	SILICON ROHM	
D121	1SS133	SILICON ROHM	
D122	1SS133	SILICON ROHM	

△ : SAFETY PARTS

Diodes

ITEM	PART NUMBER	DESCRIPTION	AREA
D123	1SS133	SILICON ROHM	
D151	1SS133	SILICON ROHM	C
D152	1SS133	SILICON ROHM	A
D153	1SS133	SILICON ROHM	B
D154	1SS133	SILICON ROHM	A
D154	1SS133	SILICON ROHM	G
D155	1SS133	SILICON ROHM	B
D190	1SS133	SILICON ROHM	
D191	1SS133	SILICON ROHM	
D192	MTZ5.1JC	ZENER ROHM	
D201	1SS133	SILICON ROHM	
D205	1SS133	SILICON ROHM	
D210	MTZ5.6JC	ZENER ROHM	
VC102	SVC342(L)	VARICAP SANYO	
VC106	SVC342(L)	VARICAP SANYO	D
VC106	SVC342(L)	VARICAP SANYO	E
VC106	SVC342(L)	VARICAP SANYO	F
VC106	SVC342(L)	VARICAP SANYO	G

△ : SAFETY PARTS

Capacitors

ITEM	PART NUMBER	DESCRIPTION	AREA
C101	QCF21HP-223	0.022MF 50V CERAMIC	
C110	QCZ0205-155	1.5MF 25V CERAMIC	
C122	QCF21HP-223	0.022MF 50V CERAMIC	
C126	QCF21HP-223	0.022MF 50V CERAMIC	
C132	QCS21HJ-561	560PF 50V CERAMIC	
C133	QCF21HP-223	0.022MF 50V CERAMIC	
C134	QETB1EM-106	10MF 25V ELECTRO	
C135	QCC21EM-223	0.022MF 25V CERAMIC	
C136	QCT26CH-180	18PF 50V CERAMIC	
C137	QCT26CH-221	220PF 50V CERAMIC	
C138	QCT26CH-241	240PF 50V CERAMIC	
C139	QCC21EM-223	0.022MF 25V CERAMIC	D
C139	QCC21EM-223	0.022MF 25V CERAMIC	E
C139	QCC21EM-223	0.022MF 25V CERAMIC	F
C139	QCC21EM-223	0.022MF 25V CERAMIC	G
C141	QCS21HJ-270	27PF 50V CERAMIC	D
C141	QCS21HJ-270	27PF 50V CERAMIC	E
C141	QCS21HJ-270	27PF 50V CERAMIC	F
C142	QCY21HK-272	2700PF 50V CERAMIC	D
C142	QCY21HK-272	2700PF 50V CERAMIC	E
C142	QCY21HK-272	2700PF 50V CERAMIC	F
C142	QCY21HK-272	2700PF 50V CERAMIC	G
C143	QCHB1EZ-223	0.022MF 25V CERAMIC	D
C143	QCHB1EZ-223	0.022MF 25V CERAMIC	E
C143	QCHB1EZ-223	0.022MF 25V CERAMIC	F
C143	QCHB1EZ-223	0.022MF 25V CERAMIC	G
C144	QETB1EM-106	10MF 25V ELECTRO	D
C144	QETB1EM-106	10MF 25V ELECTRO	E
C144	QETB1EM-106	10MF 25V ELECTRO	F
C144	QETB1EM-106	10MF 25V ELECTRO	G
C146	QCT26CH-680	68PF 50V CERAMIC	D
C146	QCT26CH-680	68PF 50V CERAMIC	E
C146	QCT26CH-680	68PF 50V CERAMIC	F
C146	QCT26CH-680	68PF 50V CERAMIC	G
C147	QCT26CH-220	22PF 50V CERAMIC	D
C147	QCT26CH-220	22PF 50V CERAMIC	E
C147	QCT26CH-220	22PF 50V CERAMIC	F
C147	QCT26CH-220	22PF 50V CERAMIC	G
C148	QCT26CH-121	120PF 50V CERAMIC	D
C148	QCT26CH-121	120PF 50V CERAMIC	E
C148	QCT26CH-121	120PF 50V CERAMIC	F
C148	QCT26CH-121	120PF 50V CERAMIC	G
C149	QCF21HP-223	0.022MF 50V CERAMIC	
C150	QCHB1EZ-223	0.022MF 25V CERAMIC	
C151	QCF21HP-223	0.022MF 50V CERAMIC	
C152	QCF21HP-223	0.022MF 50V CERAMIC	
C153	QCC21EM-223	0.022MF 25V CERAMIC	
C154	QCF21HP-223	0.022MF 50V CERAMIC	
C155	QCHB1EZ-223	0.022MF 25V CERAMIC	
C156	QETB1EM-106	10MF 25V ELECTRO	
C157	QETB1EM-106	10MF 25V ELECTRO	
C158	QCB1HK-101	100PF 50V CERAMIC	
C159	QCB1HK-101	100PF 50V CERAMIC	
C160	QCB1HK-221	220PF 50V CERAMIC	
C161	QCHB1EZ-223	0.022MF 25V CERAMIC	
C162	QETB1EM-106	10MF 25V ELECTRO	
C163	QFN81HK-102	1000PF 50V MYLAR	
C164	QCHB1EZ-223	0.022MF 25V CERAMIC	
C165	QETB1EM-106	10MF 25V ELECTRO	
C166	QETB1EM-225	2.2MF 50V ELECTRO	
C167	QETB1EM-225	2.2MF 50V ELECTRO	
C168	QETB1EM-475	4.7MF 50V ELECTRO	
C169	QCF21HP-223	0.022MF 50V CERAMIC	
C170	QCHB1EZ-223	0.022MF 25V CERAMIC	
C171	QETB1EM-106	10MF 25V ELECTRO	
C172	QCVB1CM-103	0.011F 16V CERAMIC	
C173	QFN81HK-393	0.039F 50V MYLAR	A
C173	QFN81HK-393	0.039F 50V MYLAR	B
C173	QFN81HK-223	0.022F 50V MYLAR	C

△ : SAFETY PARTS

Capacitors

Δ	ITEM	PART NUMBER	DESCRIPTION	AREA
	C173	GFNB1HK-223	0.022HF 50V MYLAR	D
	C173	GFNB1HK-223	0.022HF 50V MYLAR	E
	C173	GFNB1HK-223	0.022HF 50V MYLAR	F
	C173	GFNB1HK-223	0.022HF 50V MYLAR	G
	C174	QFLB1HK-473	0.047HF 50V MYLAR	
	C175	QETB1EM-106	10MF 25V ELECTRO	
	C176	QCY21HK-102	1000PF 50V CERAMIC	
	C177	QCS21HJ-821	820PF 50V CERAMIC	A
	C177	QCS21HJ-821	820PF 50V CERAMIC	B
	C177	QCS21HJ-391	390PF 50V CERAMIC	C
	C177	QCS21HJ-391	390PF 50V CERAMIC	D
	C177	QCS21HJ-391	390PF 50V CERAMIC	E
	C177	QCS21HJ-561	560PF 50V CERAMIC	F
	C177	QCS21HJ-391	390PF 50V CERAMIC	G
	C178	QCS21HJ-821	820PF 50V CERAMIC	A
	C178	QCS21HJ-821	820PF 50V CERAMIC	B
	C178	QCS21HJ-391	390PF 50V CERAMIC	C
	C178	QCS21HJ-391	390PF 50V CERAMIC	D
	C178	QCS21HJ-391	390PF 50V CERAMIC	E
	C178	QCS21HJ-561	560PF 50V CERAMIC	F
	C178	QCS21HJ-391	390PF 50V CERAMIC	G
	C179	QETB1HM-225	2.2MF 50V ELECTRO	
	C180	QETB1HM-225	2.2MF 50V ELECTRO	
	C181	QETB1EM-106	10MF 25V ELECTRO	
	C182	QETB1HM-225	2.2MF 50V ELECTRO	
	C183	QETB1HM-105	1MF 50V ELECTRO	
	C184	QETB1HM-105	1MF 50V ELECTRO	
	C185	QETB1HM-225	2.2MF 50V ELECTRO	
	C186	QETB1HM-474	0.47HF 50V ELECTRO	
	C191	QETB1HM-475	4.7HF 50V ELECTRO	
	C192	QCC21EM-473	0.047HF 25V CERAMIC	
	C193	QCS21HJ-180	18PF 50V CERAMIC	
	C194	QCS21HJ-180	18PF 50V CERAMIC	
	C195	QEN51HM-474	0.47HF 50V NON POLE	
	C196	QCY21HK-102	1000PF 50V CERAMIC	
	C197	QCF21HP-223	0.022HF 50V CERAMIC	
	C198	QCF21HP-103	0.01HF 50V CERAMIC	
	C199	QETB1HM-475	4.7HF 50V ELECTRO	
	C202	QETB1HM-225	2.2MF 50V ELECTRO	
	C204	QCT26CH-120	12PF 50V CERAMIC	
	C205	QCZ0202-155	1.5MF 25V CERAMIC	
	C206	QCVB1CM-103	0.01MF 16V CERAMIC	
	C207	QCF21HP-223	0.022MF 50V CERAMIC	
	C208	QEK61AM-227Z	220MF 10V ELECTRO	
	C209	QCVB1CM-103	0.01MF 16V CERAMIC	
	C210	QCVB1CM-103	0.01MF 16V CERAMIC	
	C211	QCF21HP-103	0.01MF 50V CERAMIC	
	C220	QCF21HP-103	0.01MF 50V CERAMIC	
	C221	QEA40HZ-10AB	ELECTRO	
	C222	QETB1CM-477	470MF 16V ELECTRO	
	C223	QCF21HP-103	0.01MF 50V CERAMIC	
	C224	QCGB1HK-102	1000PF 50V CERAMIC	
	C225	QCGB1HK-102	1000PF 50V CERAMIC	
	C226	QETB1AM-227	220MF 10V ELECTRO	
	C227	QCVB1CM-103	0.01MF 16V CERAMIC	
	C229	QETB1CM-477	470MF 16V ELECTRO	
	C230	QETB1EM-476	47MF 25V ELECTRO	
	C232	QCVB1CM-103	0.01MF 16V CERAMIC	
	C241	QCF21HP-223	0.022MF 50V CERAMIC	

Δ : SAFETY PARTS

Resistors

Δ	ITEM	PART NUMBER	DESCRIPTION	AREA
	R118	QRD167J-332	3.3K 1/6W CARBON	
	R119	QRD167J-221	220 1/6W CARBON	
	R121	QRD167J-391	390 1/6W CARBON	
	R122	QRD167J-272	2.7K 1/6W CARBON	
	R123	QRD167J-102	1K 1/6W CARBON	
	R124	QRD167J-681	680 1/6W CARBON	
	R125	QRD167J-332	3.3K 1/6W CARBON	
	R126	QRD167J-221	220 1/6W CARBON	
	R131	QRD167J-331	330 1/6W CARBON	
	R132	QRD167J-103	10K 1/6W CARBON	
	R133	QRD167J-473	47K 1/6W CARBON	
	R134	QRD167J-103	10K 1/6W CARBON	D
	R134	QRD167J-103	10K 1/6W CARBON	E
	R134	QRD167J-103	10K 1/6W CARBON	F
	R134	QRD167J-103	10K 1/6W CARBON	G
	R135	QRD167J-470	47 1/6W CARBON	
	R136	QRD167J-103	10K 1/6W CARBON	
	R141	QRD167J-472	4.7K 1/6W CARBON	D
	R141	QRD167J-472	4.7K 1/6W CARBON	E
	R141	QRD167J-472	4.7K 1/6W CARBON	F
	R141	QRD167J-472	4.7K 1/6W CARBON	G
	R142	QRD167J-331	330 1/6W CARBON	D
	R142	QRD167J-331	330 1/6W CARBON	E
	R142	QRD167J-331	330 1/6W CARBON	F
	R142	QRD167J-331	330 1/6W CARBON	G
	R143	QRD167J-103	10K 1/6W CARBON	D
	R143	QRD167J-103	10K 1/6W CARBON	E
	R143	QRD167J-103	10K 1/6W CARBON	F
	R143	QRD167J-103	10K 1/6W CARBON	G
	R144	QRD167J-473	47K 1/6W CARBON	D

Δ : SAFETY PARTS

Resistors

Δ	ITEM	PART NUMBER	DESCRIPTION	AREA
	R144	QRD167J-473	47K 1/6W CARBON	E
	R144	QRD167J-473	47K 1/6W CARBON	F
	R144	QRD167J-473	47K 1/6W CARBON	G
	R145	QRD167J-103	10K 1/6W CARBON	D
	R145	QRD167J-103	10K 1/6W CARBON	E
	R145	QRD167J-103	10K 1/6W CARBON	F
	R145	QRD167J-103	10K 1/6W CARBON	G
	R146	QRD167J-560	56 1/6W CARBON	
	R147	QRD167J-103	10K 1/6W CARBON	
	R148	QRD167J-103	10K 1/6W CARBON	
	R149	QRD167J-223	22K 1/6W CARBON	
	R150	QRD167J-103	10K 1/6W CARBON	
	R151	QRD167J-222	2.2K 1/6W CARBON	
	R153	QRD167J-103	10K 1/6W CARBON	
	R154	QRD167J-103	10K 1/6W CARBON	
	R155	QRD167J-562	5.6K 1/6W CARBON	
	R156	QRD167J-822	8.2K 1/6W CARBON	
	R157	QRD167J-103	10K 1/6W CARBON	
	R158	QRD167J-183	18K 1/6W CARBON	A
	R158	QRD167J-273	27K 1/6W CARBON	B
	R158	QRD167J-273	27K 1/6W CARBON	C
	R158	QRD167J-273	27K 1/6W CARBON	D
	R158	QRD167J-273	27K 1/6W CARBON	E
	R158	QRD167J-273	27K 1/6W CARBON	F
	R158	QRD167J-273	27K 1/6W CARBON	G
	R159	QRD167J-561	560 1/6W CARBON	
	R160	QRD167J-562	5.6K 1/6W CARBON	A
	R160	QRD167J-562	5.6K 1/6W CARBON	B
	R160	QRD167J-183	18K 1/6W CARBON	C
	R160	QRD167J-183	18K 1/6W CARBON	D
	R160	QRD167J-183	18K 1/6W CARBON	E
	R160	QRD167J-822	8.2K 1/6W CARBON	F
	R160	QRD167J-183	18K 1/6W CARBON	G
	R161	QRD167J-823	82K 1/6W CARBON	A
	R161	QRD167J-823	82K 1/6W CARBON	B
	R161	QRD167J-124	120K 1/6W CARBON	C
	R161	QRD167J-124	120K 1/6W CARBON	D
	R161	QRD167J-124	120K 1/6W CARBON	E
	R161	QRD167J-823	82K 1/6W CARBON	F
	R161	QRD167J-124	120K 1/6W CARBON	G
	R162	QRD167J-823	82K 1/6W CARBON	A
	R162	QRD167J-823	82K 1/6W CARBON	B
	R162	QRD167J-124	120K 1/6W CARBON	C
	R162	QRD167J-124	120K 1/6W CARBON	D
	R162	QRD167J-124	120K 1/6W CARBON	E
	R162	QRD167J-823	82K 1/6W CARBON	F
	R162	QRD167J-124	120K 1/6W CARBON	G
	R163	QRD167J-472	4.7K 1/6W CARBON	A
	R163	QRD167J-472	4.7K 1/6W CARBON	B
	R163	QRD167J-332	3.3K 1/6W CARBON	C
	R163	QRD167J-332	3.3K 1/6W CARBON	D
	R163	QRD167J-332	3.3K 1/6W CARBON	E
	R163	QRD167J-332	3.3K 1/6W CARBON	F
	R163	QRD167J-332	3.3K 1/6W CARBON	G
	R164	QRD167J-472	4.7K 1/6W CARBON	A
	R164	QRD167J-472	4.7K 1/6W CARBON	B
	R164	QRD167J-332	3.3K 1/6W CARBON	C
	R164	QRD167J-332	3.3K 1/6W CARBON	D
	R164	QRD167J-332	3.3K 1/6W CARBON	E
	R164	QRD167J-332	3.3K 1/6W CARBON	F
	R164	QRD167J-332	3.3K 1/6W CARBON	G
	R165	QRD167J-184	180K 1/6W CARBON	A
	R165	QRD167J-184	180K 1/6W CARBON	B
	R165	QRD167J-274	270K 1/6W CARBON	C
	R165	QRD167J-274	270K 1/6W CARBON	D
	R165	QRD167J-274	270K 1/6W CARBON	E
	R165	QRD167J-274	270K 1/6W CARBON	F
	R165	QRD167J-274	270K 1/6W CARBON	G
	R166	QRD167J-184	180K 1/6W CARBON	A
	R166	QRD167J-184	180K 1/6W CARBON	B
	R166	QRD167J-274	270K 1/6W CARBON	C
	R166	QRD167J-274	270K 1/6W CARBON	D
	R166	QRD167J-274	270K 1/6W CARBON	E
	R166	QRD167J-274	270K 1/6W CARBON	F
	R166	QRD167J-274	270K 1/6W CARBON	G
	R167	QRD167J-393	39K 1/6W CARBON	A
	R167	QRD167J-393	39K 1/6W CARBON	B
	R167	QRD167J-473	47K 1/6W CARBON	C
	R167	QRD167J-473	47K 1/6W CARBON	D
	R167	QRD167J-473	47K 1/6W CARBON	E
	R167	QRD167J-473	47K 1/6W CARBON	F
	R167	QRD167J-473	47K 1/6W CARBON	G
	R168	QRD167J-103	10K 1/6W CARBON	
	R169	QRD167J-103	10K 1/6W CARBON	
	R171	QRD167J-682	6.8K 1/6W CARBON	
	R172	QRD167J-682	6.8K 1/6W CARBON	
	R180	QRD167J-103	10K 1/6W CARBON	
	R181	QRD167J-222	2.2K 1/6W CARBON	
	R182	QRD167J-181	180 1/6W CARBON	
	R190	QRD167J-103	10K 1/6W CARBON	
	R191	QRD167J-562	5.6K 1/6W CARBON	
	R193	QRD167J-103	10K 1/6W CARBON	
	R194	QRD167J-103	10K 1/6W CARBON	
	R195	QRD167J-473	47K 1/6W CARBON	
	R196	QRD167J-103	10K 1/6W CARBON	A

Δ : SAFETY PARTS

Resistors

Δ	ITEM	PART NUMBER	DESCRIPTION	AREA
	R196	QRD167J-103	10K 1/6W CARBON	B
	R196	QRD167J-103	10K 1/6W CARBON	C
	R196	QRD167J-222	2.2K 1/6W CARBON	D
	R196	QRD167J-222	2.2K 1/6W CARBON	E
	R196	QRD167J-222	2.2K 1/6W CARBON	F
	R196	QRD167J-222	2.2K 1/6W CARBON	G
	R197	QRD167J-222	2.2K 1/6W CARBON	
	R198	QRD167J-332	3.3K 1/6W CARBON	A
	R198	QRD167J-332	3.3K 1/6W CARBON	B
	R198	QRD167J-332	3.3K 1/6W CARBON	C
	R198	QRD167J-822	8.2K 1/6W CARBON	D
	R198	QRD167J-822	8.2K 1/6W CARBON	E
	R198	QRD167J-822	8.2K 1/6W CARBON	F
	R198	QRD167J-822	8.2K 1/6W CARBON	G
	R199	QRD167J-472	4.7K 1/6W CARBON	
	R205	QRD167J-473	4.7K 1/6W CARBON	
	R209	QRD167J-104	100K 1/6W CARBON	
	R210	QRD167J-222	2.2K 1/6W CARBON	
	R211	QRD167J-103	10K 1/6W CARBON	
	R212	QRD167J-473	4.7K 1/6W CARBON	
	R213	QRD167J-472	4.7K 1/6W CARBON	
	R214	QRD167J-102	1K 1/6W CARBON	
	R215	QRD167J-470	47 1/6W CARBON	
	R228	QRD167J-222	2.2K 1/6W CARBON	
	R229	QRD14CJ-220S	22 1/4W UNF. CARBON	
	R232	QRD167J-153	15K 1/6W CARBON	

Δ : SAFETY PARTS

Others

Δ	ITEM	PART NUMBER	DESCRIPTION	AREA
	FE101	EAF2203-003	FRONT END	E
	FE101	EAF2203-003	FRONT END	F
	FE101	EAF2203-003	FRONT END	G
	FL201	ELU0001-101	FL TUBE	
	FS201	E306805-021	FELT SPACER	
	FW001	EWP902-019	PLUG WIRE ASSY	
	FW101	EWR398-25LST	FLAT WIRE(9PIN)	
	FW102	EWR398-25LST	FLAT WIRE(9PIN)	
	JB211	EMV7130-011	CONNECTOR(11PIN)	
	JT101	EMV7122-004	CONNECTOR(4PIN)	
	JT102	EMV7122-005	CONNECTOR(5PIN)	
	JT103	EMV7122-004	CONNECTOR(4PIN)	
	JT104	EMV7122-005	CONNECTOR(5PIN)	
	LP101	EQF0101-002	LOW PASS FILTER	
	LP102	EQF0102-001	LOW PASS FILTER	D
	LP102	EQF0102-001	LOW PASS FILTER	E
	LP102	EQF0102-001	LOW PASS FILTER	F
	LP102	EQF0102-001	LOW PASS FILTER	G
	TC105	ENZ1003-006	TRIMMER	
	TC106	ENZ1003-006	TRIMMER	D
	TC106	ENZ1003-006	TRIMMER	E
	TC106	ENZ1003-006	TRIMMER	F
	TC106	ENZ1003-006	TRIMMER	G
	TC201	ENZ1003-015	TRIMMER	
	XT102	ECX0007-200KC	RESONATOR	
	XT103	ECX0000-456KR	RESONATOR	
	XT201	ECX4194-304CF	RESONATOR	

Δ : SAFETY PARTS

Others

Δ	ITEM	PART NUMBER	DESCRIPTION	AREA
	L101	EMW10101-002	PRINTED BOARD	
	L106	EQL4004-1R0	INDUCTOR	
	L120	EQL3001-102K	INDUCTOR	
	L120	EQL4004-1R0	INDUCTOR	
	S151	QSS6A12-E01	SLIDE SWITCH(AM CH. SPACE)	B
	S200	ESPO001-018	TACT SWITCH(WAKE UP/SLEEP)	
	S201	ESPO001-018	TACT SWITCH(CLOCK ADJ)	
	S202	ESPO001-018	TACT SWITCH(UP)	
	S210	ESPO001-018	TACT SWITCH(TIMER 2)	
	S211	ESPO001-018	TACT SWITCH(CANCEL)	
	S212	ESPO001-018	TACT SWITCH(DOWN)	
	S214	ESPO001-018	TACT SWITCH(AM)	
	S220	ESPO001-018	TACT SWITCH(TIMER 1)	
	S221	ESPO001-018	TACT SWITCH(MEMORY)	
	S222	ESPO001-018	TACT SWITCH(PRESET DOWN)	
	S224	ESPO001-018	TACT SWITCH(FM)	
	S230	ESPO001-018	TACT SWITCH(DAILY)	
	S232	ESPO001-018	TACT SWITCH(PRESET UP)	
	S234	ESPO001-018	TACT SWITCH(FM MODE/MUTE)	
	T101	EQR1111-014	AM RF COIL	
	T102	EQR1111-005	AM RF COIL	D
	T102	EQR1111-005	AM RF COIL	E
	T102	EQR1111-005	AM RF COIL	F
	T102	EQR1111-005	AM RF COIL	G
	T103	EQR1207-017	MW OSC COIL	
	T104	EQR1307-010	LW OSC COIL	D
	T104	EQR1307-010	LW OSC COIL	E
	T104	EQR1307-010	LW OSC COIL	F
	T104	EQR1307-010	LW OSC COIL	G
	T105	EQT2140-017	I.F. TRANSFORMER	
	T107	ECB1560-008	CERAMIC FILTER	
	AT101	EMB41YV-401K	ANTENNA TERMINAL	A
	AT101	EMB41YV-401K	ANTENNA TERMINAL	B
	AT101	EMB41YV-401K	ANTENNA TERMINAL	C
	AT101	EMB41YV-301K	ANTENNA TERMINAL	D
	AT101	EMB41YV-301K	ANTENNA TERMINAL	E
	AT101	EMB41YV-301K	ANTENNA TERMINAL	F
	AT101	EMB41YV-301K	ANTENNA TERMINAL	G
	BK201	E306958-002	FL DISPLAY HOLDER	
	CF101	ECB2123-006R	CERAMIC FILTER	A
	CF101	ECB2123-006R	CERAMIC FILTER	B
	CF101	ECB2123-006R	CERAMIC FILTER	C
	CF101	ECB2118-007R	CERAMIC FILTER	D
	CF101	ECB2118-007R	CERAMIC FILTER	E
	CF101	ECB2118-007R	CERAMIC FILTER	F
	CF101	ECB2118-007R	CERAMIC FILTER	G
	CF102	ECB2123-006R	CERAMIC FILTER	A
	CF102	ECB2123-006R	CERAMIC FILTER	B
	CF102	ECB2123-006R	CERAMIC FILTER	C
	CF102	ECB2118-007R	CERAMIC FILTER	D
	CF102	ECB2118-007R	CERAMIC FILTER	E
	CF102	ECB2118-007R	CERAMIC FILTER	F
	CF102	ECB2118-007R	CERAMIC FILTER	G
	EP102	E70859-001	EARTH PLATE	
	EP103	E70859-001	EARTH PLATE	
	EP110	E70225-001	EARTH PLATE	
	FE101	EAF2203-001	FRONT END	A
	FE101	EAF2203-001	FRONT END	B
	FE101	EAF2203-001	FRONT END	C
	FE101	EAF2203-003	FRONT END	D

Δ : SAFETY PARTS

Packing Materials and Part Numbers

(Only for Continental Europe, the U.K., Germany, Italy)

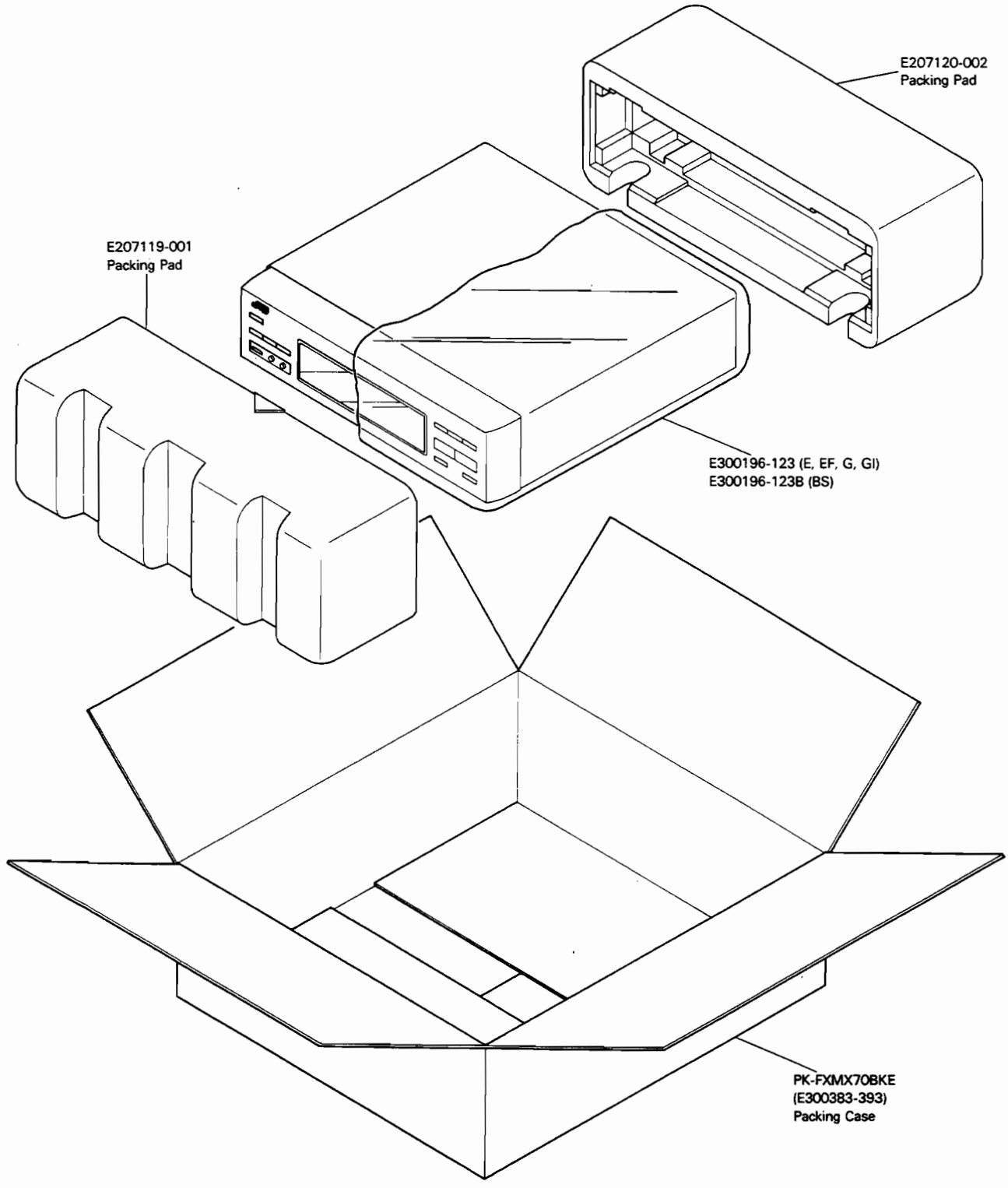

The Marks Designated Areas

G.....Germany	E, EF.....Continental Europe
BS.....the U.K.	No mark indicates all areas.
GI.....Italy	



JVC

SERVICE MANUAL

COMPACT COMPONENT SYSTEM

MODEL NO. **DX-MX70BK/CA-MX70BK**

(UNIT NO. XL-MX70BK)



COMPACT
disc
DIGITAL AUDIO

- * For instruction manual, please refer to the CA-MX70BK (S.M.NO.20243) or DX-MX70BK (S.M.NO.20249).
- * AX-MX70BK is needed (for power supply etc.) when servicing.

Contents

Safety Precautions	1-2	Flow of Functional Operation	
Important for Laser Products	1-3	until TOC is read	1-14
Description of LSIs	1-4	Adjustment Procedures	1-15
Internal Connections of		Troubleshooting	1-16
FL Display Tube	1-9	Connection Diagram	1-22
Disassembly Procedures	1-10	Block Diagram	1-23
Application Points for Grease	1-12	Schematic Diagrams	Insertion
Maintenance of Laser Pickup	1-13	Printed Circuit Board	Insertion
Replacement of Laser Pickup	1-13	Parts List	Insertion

Safety Precautions

1. The design of this product contains special hardware and many circuits and components specially for safety purposes. For continued protection, no changes should be made to the original design unless authorized in writing by the manufacturer. Replacement parts must be identical to those used in the original circuits. Services should be performed by qualified personnel only.
2. Alterations of the design or circuitry of the product should not be made. Any design alterations of the product should not be made. Any design alterations or additions will void the manufacturer's warranty and will further relieve the manufacture of responsibility for personal injury or property damage resulting therefrom.
3. Many electrical and mechanical parts in the products have special safety-related characteristics. These characteristics are often not evident from visual inspection nor can the protection afforded by them necessarily be obtained by using replacement components rated for higher voltage, wattage, etc. Replacement parts which have these special safety characteristics are identified in the Parts List of Service Manual. Electrical components having such features are identified by shading on the schematics and by (Δ) on the Parts List in the Service Manual. The use of a substitute replacement which does not have the same safety characteristics as the recommended replacement parts shown in the Parts List of Service Manual may create shock, fire, or other hazards.
4. The leads in the products are routed and dressed with ties, clamps, tubings, barriers and the like to be separated from live parts, high temperature parts, moving parts and/or sharp edges for the prevention of electric shock and fire hazard. When service is required, the original lead routing and dress should be observed, and it should be confirmed that they have been returned to normal, after re-assembling.
5. Leakage current check (Electrical shock hazard testing)
After re-assembling the product, always perform an isolation check on the exposed metal parts of the product (antenna terminals, knobs, metal cabinet, screw heads, headphone jack, control shafts, etc.) to be sure the product is safe to operate without danger of electrical shock.
Do not use a line isolation transformer during this check.

- Plug the AC line cord directly into the AC outlet. Using a "Leakage Current Tester", measure the leakage current from each exposed metal parts of the cabinet, particularly any exposed metal part having a return path to the chassis, to a known good earth ground. Any leakage current must not exceed 0.5mA AC (r.m.s.).

- Alternate check method

Plug the AC line cord directly into the AC outlet. Use an AC voltmeter having, 1,000 ohms per volt or more sensitivity in the following manner. Connect a 1,500 Ω 10 W resistor paralleled by a 0.15 μ F AC-type capacitor between an exposed metal part and a known good earth ground.

Measure the AC voltage across the resistor with the AC voltmeter.

Move the resistor connection to each exposed metal part, particularly any exposed metal part having a return path to the chassis, and measure the AC voltage across the resistor.

Now, reverse the plug in the AC outlet and repeat each measurement. Any voltage measured must not exceed 0.75 V AC (r.m.s.). This corresponds to 0.5 mA AC (r.m.s.).

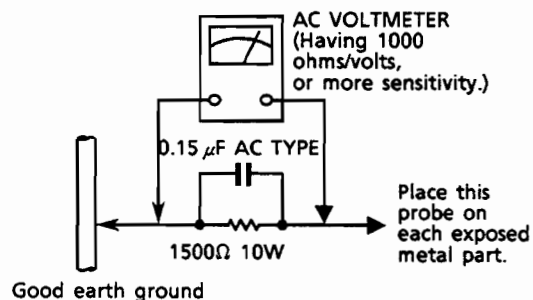

Warning

1. This equipment has been designed and manufactured to meet international safety standards.
2. It is the legal responsibility of the repairer to ensure that these safety standards are maintained.
3. Repairs must be made in accordance with the relevant safety standards.
4. It is essential that safety critical components are replaced by approved parts.
5. If mains voltage selector is provided, check setting for local voltage.

Important for Laser Products

1. **CLASS 1 LASER PRODUCT**
2. **DANGER** : Invisible laser radiation when open and interlock failed or defeated. Avoid direct exposure to beam.
3. **CAUTION** : There are no serviceable parts inside the Laser Unit. Do not disassemble the Laser Unit. Replace the complete Laser Unit if it malfunctions.
4. **CAUTION** : The compact disc player uses invisible laser radiation and is equipped with safety switches which prevent emission of radiation when the drawer is open and the safety interlocks have failed or are defeated. It is dangerous to defeat the safety switches.
5. **CAUTION** : If safety switches malfunction, the laser is able to function.
6. **CAUTION** : Use of controls, adjustments or performance of procedures other than those specified herein may result in hazardous radiation exposure.
7. **CAUTION** : The compact disc player provides a laser diode of wavelength 780-790nm and optical output power typical 3mW at the laser diode.

WARNING : Osynlig laserstråling når denna del är öppnad och spärren är urkopplad. Betrakta ej strålen.

VARO : Avattaessa ja suojalukitus ohitettaessa olet alttiina näkymättömälle lasersäteilylle. Älä katso säteeseen.

ADVARSEL : Usynlig laserstråling ved åbning, når sikkerhedsafbrydere er ude af funktion. Undgå udsættelse for stråling.

ADVARSEL : Usynlig laserstråling ved åbning, når sikkerhetsbryteren er avslott. unngå utsettelse for stråling.

REPRODUCTION AND POSITION OF LABELS

WARNING LABEL (Except for the U.S.A.)

DANGER: Invisible laser radiation when open and interlock failed or defeated. AVOID DIRECT EXPOSURE TO BEAM. (e)

WARNING: Osynlig laserstråling når denna del är öppnad och spärren är urkopplad. Betrakta ej strålen. (s)

ADVARSEL: Usynlig laserstråling ved åbning, når sikkerhedsafbrydere er ude af funktion. Undgå udsættelse for stråling. (d)

VARO: Avattaessa ja suojalukitus ohitettaessa olet alttiina näkymättömälle lasersäteilylle. Älä katso säteeseen. (f)

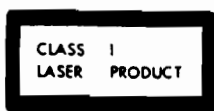
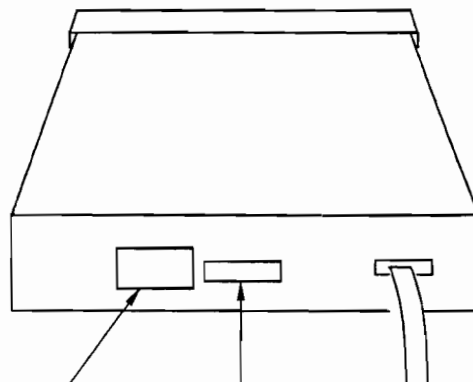
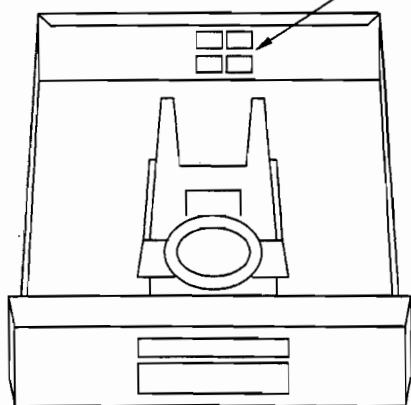

CLASSIFICATION LABEL
(Except for the U.S.A. and Canada)

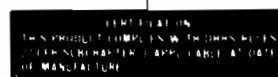

CERTIFICATION PRINT BY DHHS
(Only for the U.S.A.)

Description of ICs

■ YM3805-H IC841

1. Outline:

YM3805-H is a C-MOS LSI for signal processing (SGP) and servo control (SVC) in a CD player. It is used for the demodulation of the EFM signal from the laser pickup, detection/correction of the error signal, signal processing in digital filtering, etc. and for various servo controls (focusing, tracking, spindle and feed servos).

2. Terminal Layout

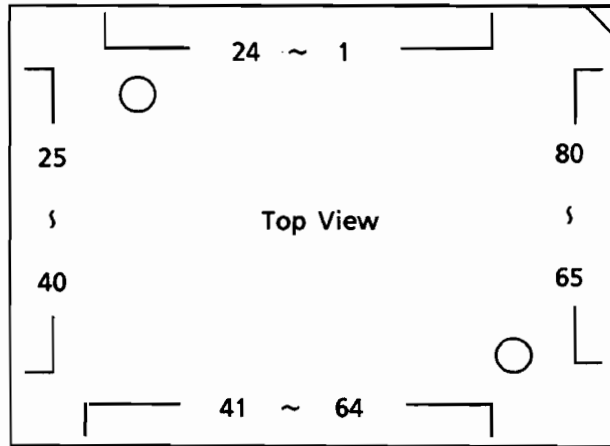

3. Internal Block Diagram

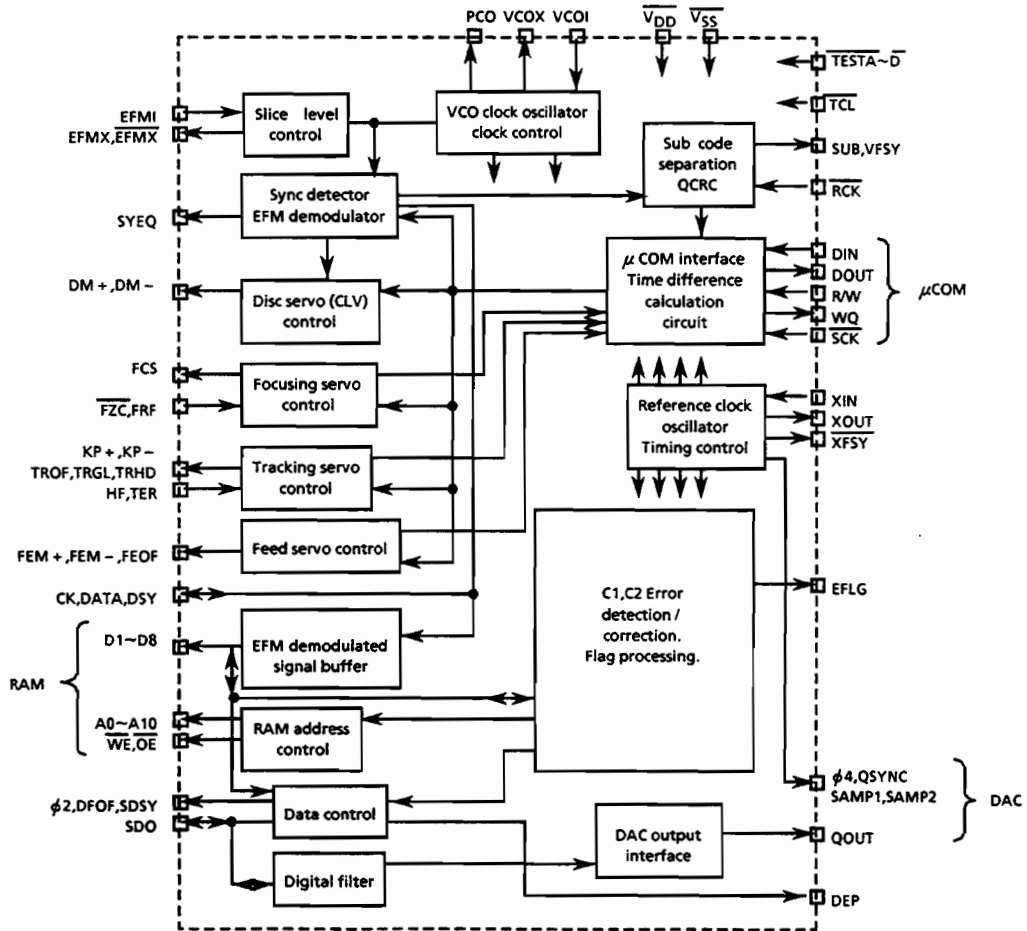

4. Pin Functions Description

Pin No.	Symbol	I/O	Functions and Operations
1 32 72	V _{DD}	-	These are +5V power supply terminals.
2 · 3	VCOX VCOI	O I	These terminals are used for oscillating VCO (Voltage Controlled Oscillator) clock. (8.6436MHz)
4	PCO	O	This terminal is control output terminal for VCO clock, and sets oscillation circuit to rise frequency when average voltage is high.
5 · 9 41 · 78	V _{SS}	-	These are ground terminals.
6	EFMX	O	These terminals connect with EFM signal slice level control circuit.
7	EFMX	O	Amplified EFM signal by limited amplitude comes from these terminals.
8	EFMI	I	Input the EFM signal (1~2Vpp) to the this terminal.
10	SYEQ	O	This is a monitor output terminal. It becomes "H" when there is a agreement synchronizing signal in EFM signal and inner counter.
11 12	DM + DM -	O O	They are output terminals controlling disc motor drive circuit. These do not become "H" at the same time.
13	FCS	O	This is an output terminal for taking in focus.
14	FZC	I	This is a terminal to get FZC signal which changing "H" to "L" when pick-up is in focus.
15	FRF	I	Input "H" signal when there is reflected light of compact disc at this terminal.
16	HF	I	This is a terminal inputting envelope of EFM.
17	TER	I	This is a terminal inputting tracking error signal.
19	TROF	O	This is a terminal for cutting off the tracking error signal of tracking servo circuit.
20	TRGL	O	This is an output terminal for getting down the gain of tracking servo circuit.
21	TRHD	O	This is an output terminal for holding tracking error signal of tracking servo circuit while following KP+ or KP- are output.
22	KP +	O	They are connected with tracking servo circuit.
23	KP -	O	They are terminals for searching.
24	FEOF	O	This is an output terminal for cutting off the input signal of feed servo circuit.
25	FEM +	O	There are output signals for high speed feed and they are connected with feed servo circuit.
26	FEM -	O	
27	CK	I/O	This is the check terminal. It has a 4.3218MHz; half of VCO.
35	WQ	O	This connects with microcomputer. It is a request output terminal for demanding to send the data from SVC to microcomputer.
36	R/W	I	This connects with microcomputer and it is an output terminal for switching data transmission mode. It enables to transmit data from SVC to microcomputer when R/W is "L" and from microcomputer to SVC when R/W is "H". (Read/Write)
37	DOUT	O	This is a data output terminal. It enables to transmit the data from SVC to microcomputer according SCK clock input when R/W is "L".
38	DIN	I	This is a data input terminal. It enables to transmit the data from microcomputer to SVC according SCK clock input when R/W is "H".
39	SCK	I	It is a clock input terminal needed for transmitting the data.
40 42~50 53	A0 A1~A9 A10	O	These are address output terminals and are connected to the RAM.
51	\overline{WE}	O	This terminal is connected to the RAM; the RAM is set to the write mode when this terminal is "L". (Write enable)
52	\overline{OE}	O	This terminal is connected to the RAM; the RAM is set to the read mode when this terminal is "L". (Output enable)
54~61	D8~D1	I/O	These are data Input and Output terminals and are connected to the RAM.
62	DEP	O	This terminal a Flag for de-emphasis. De-emphasis is necessary when this terminal is "H".
64	QSYNC	I/O	This terminal output the clock signals to find that the serial data is channel 1 or channel 2.
65	QOUT	O	This terminal output the digitalized audio signal. they come out channel 1 and channel 2 alternately.
68	$\Phi 4$	O	$\Phi 4$ is a 4.3218MHz crystal clock.
76	SAMP1	O	These terminals connect with D/A converter.
77	SAMP2	O	These signal are use to make deglitching signal.
79 80	XIN XOUT	I O	A crystal resonator (8.6436MHz) is connected.
18 28~31 33~34 63 66~67 69~71 73~75			Not used.

■ HD404019RB14S (IC991) : Micro-computer

1. Terminal Layout

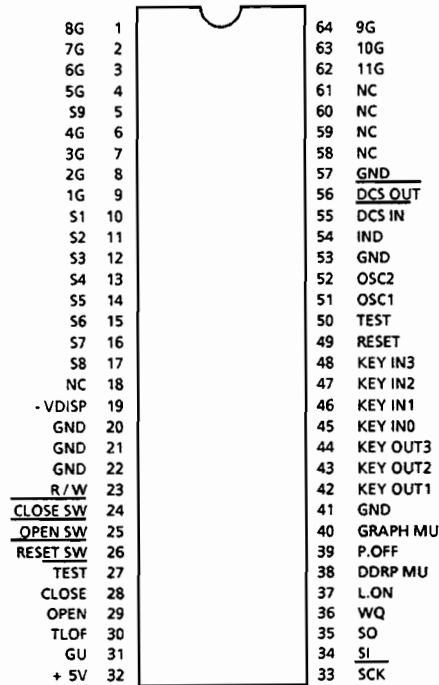

2. Pin Description

Pin No.	Symbol	I/O	Functions and Operations	Pin NO.	Symbol	I/O	Functions and Operations
1~4	8G~5G	O	FL grid control output	35	SO	O	Serial data output for IC841
5	59	O	FL segment control output	36	WQ	I	Write request signal input
6~9	4G~1G	O	FL grid control output	37	L.ON	O	Laser on signal output
10~17	S1~S8	O	FL segment control output	38	DDRP MU	O	Mute signal output when stopping
18	NC	--	Non connection	39	P.OFF	O	Power off signal output
19	-VDISP	I	FL Power supply	40	Graph mu	O	ute signal output excepting CD
20~22	GND	--	Ground	41	GND	--	Ground
23	R/W	O	Read / Write signal output	42~44	KEY OUT0 ~ KEY OUT3	O	Key matrix output
24	CLOSE SW	I	Close switch : active low	45~48	KEY IN0 ~ KEY IN3	I	Key matrix input
25	OPEN SW	I	Open switch : active low	49	RESET	I	Reset signal input
26	RESET SW	I	Reset switch : active low at the inmost position of pickup	50	TEST	I	Test mode input : connected to +5V
27	TEST	I	Test mode input	51	OSC 1	I	Clock Oscillation input
28	CLOSE	O	Close signal output	52	OSC 2	O	Clock Oscillation output
29	OPEN	O	Open signal output	53,57	GND	--	Ground
30	TLOF	O	Tracking servo off signal output	54	IND	O	Auto power off indicator signal
31	GU	O	Tracking gain up signal output	55	DCS IN	I	Compu-link signal input
32	Vcc	--	+ 5V	56	DCS OUT	O	Compu-link signal output
33	SCK	O	Clock output for IC841	58~61	NC	--	Non connection
34	SI	I	Serial data input from IC841	62~64	11G~9G	O	FL grid control output

■ LC7881-C (IC873) : D/A converter

1. Terminal Layout

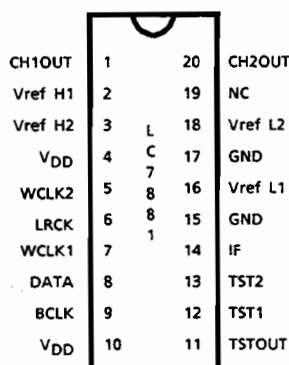

2. Block Diagram

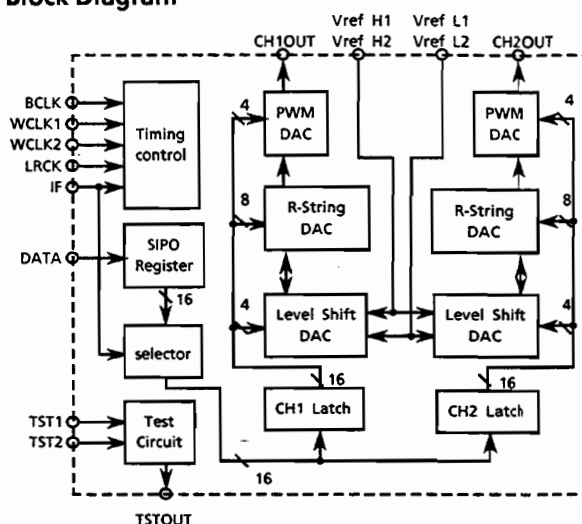

3. Pin Functions

Pin No	Symbol	I/O	Functions and Operations
1	CH1 OUT	O	Channel 1 Output pin.
2	Vref H1	I	Reference voltage "H" input pin1.
3	Vref H2	I	Reference voltage "H" input pin2.
4	V _{DD}	—	Power supply, +5V.
5	WCLK2	I	Word clock 2 input pin. When IF pin is at high level, WCLK2 pin should be set at low level. When IF pin is at low level, this generates the internal signal used to latch the CH1 data of the digital audio signal, using the falling edge of WCLK2.
6	LRCK	I	LR clock input pin. This shows the CH1 and CH2 of the input digital audio data. When LRCK is at high level, it corresponds to CH1 data. When LRCK is at low level, it corresponds to CH2 data.
7	WCLK1	I	Word clock 1 input pin. When IF pin is at high level, this pin generates the internal signal used to latch both the CH1 and CH2 data, using the falling edge of WCLK1. When IF pin is at low level, it generates the internal signal used to latch the CH2 data.
8	DATA	I	Digital audio data input pin. When IF pin is at high level, the data signal is input by each bit serially from the MSB. When IF pin is at low level, the data signal is input by each bit serially from the LSB.
9	BCLK	I	Bit clock pin. This clock signal is used when reading the digital audio data by each bit serially, and also used for PWM D/A converter.
10	V _{DD}	—	Power supply, +5V.
11	TST OUT	O	Test signal output pin. Normally leave this pin open.
12	TST1	I	Test signal input pin. Normally connect to GND terminal.
13	TST2	I	
14	IF	I	Interface select pin. When IF pin is at high level, the digital audio data is input from the MSB first. When IF pin is at low level, the digital audio data is input from the LSB first.
15	GND	—	Ground.
16	Vref L1	I	Reference voltage "L" input pin1.
17	GND	—	Ground.
18	Vref L2	I	Reference voltage "L" input pin2.
19	NC	—	No connection.
20	CH2 OUT	O	Channel 2 output pin.

XL-MX70BK

■ NJM072S (IC801) : Dual OP Amp.

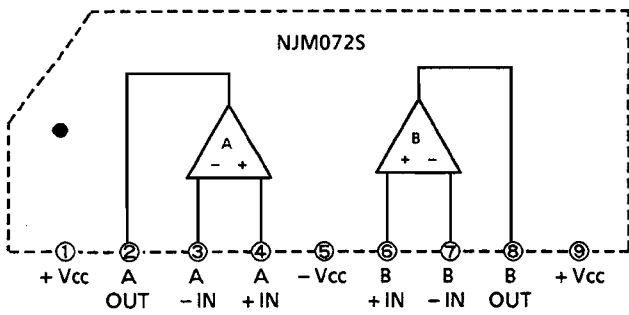

■ BA10339 (IC802) : Comparator

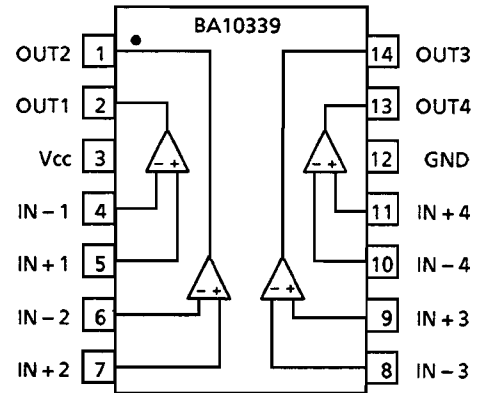

■ MN1281 (P,Q) (IC992) : Reset IC

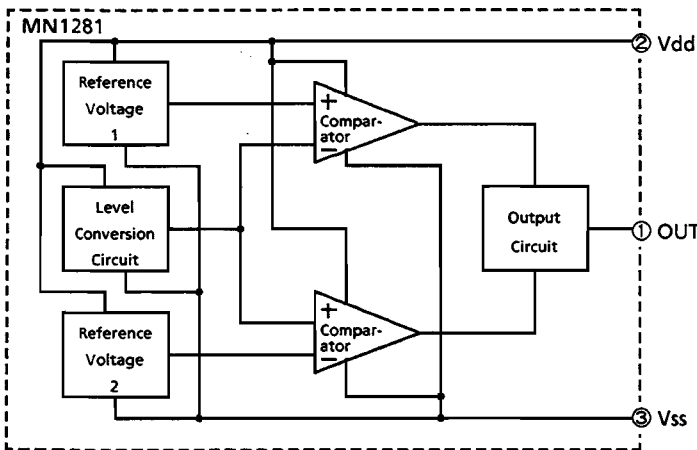

■ VC4580L (IC762,781,803) XRA15218N (IC871,872) : Dual OP Amp.

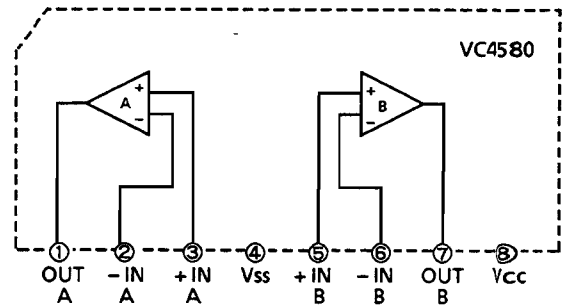

■ M5209P (IC843) : Dual OP Amp.

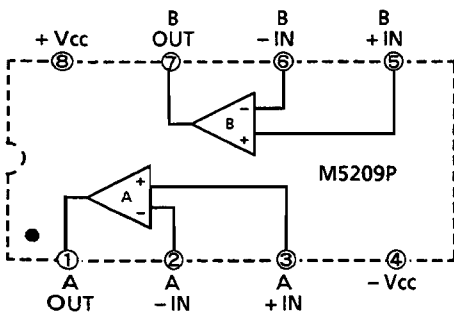

■ LC3517BS-15 (IC842) : Static RAM

A7	1	24	Vcc
A6	2	23	A8
A5	3	22	A9
A4	4	21	WE
A3	5	20	OE
A2	6	19	A10
A1	7	18	CS
A0	8	17	I/O 8
I/O 1	9	16	I/O 7
I/O 2	10	15	I/O 6
I/O 3	11	14	I/O 5
GND	12	13	I/O 4

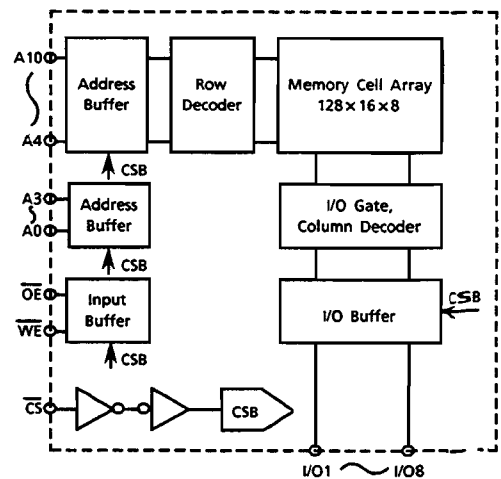

■ STA341M (IC801) : Motor Driver

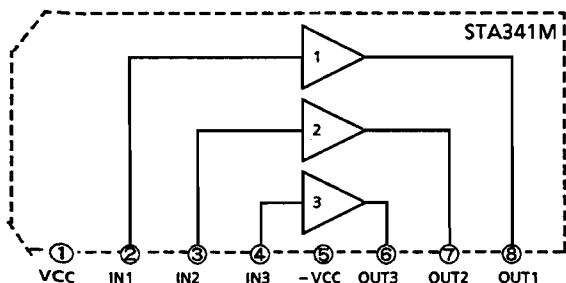

Internal Connections of FL Display Tube

■ ELU0001-114 (FL991)

1. Grid Layout

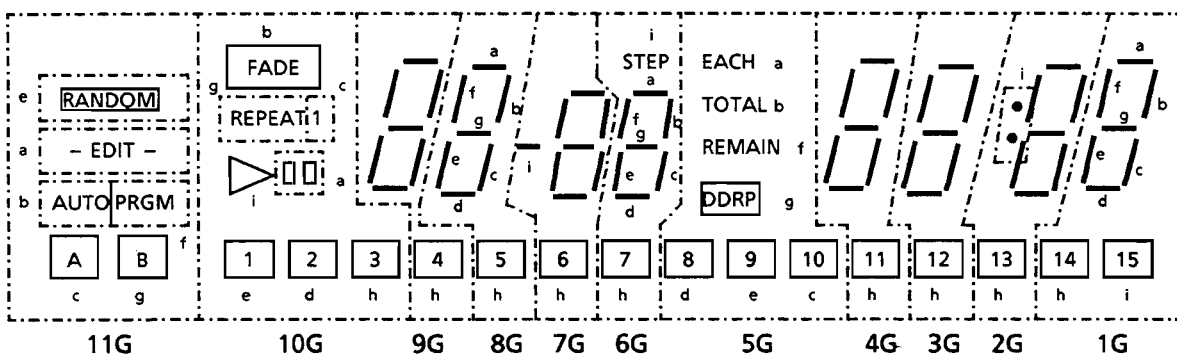

2. Pin Connection

Pin No.	1	2	3	4	5	6	7	8	9	10	11	12	13	14	15	16	17	18	19
Electrode	F1	F1	NP	NC	11G	10G	9G	8G	7G	6G	5G	P (f)	4G	3G	2G	1G	P (a)	P (b)	P (f)

Pin No.	20	21	22	23	24	25	26	27	28	29	30	31	32	33	34	35	36	37	38
Electrode	P (g)	P (c)	P (e)	P (d)	P (h)	NC	NC	NC	NC	NC	NC	NC	NC	NC	NC	NC	NP	F2	F2

Note..... F: Filament, G: Grid, a~i: Element, NP: No pin, NC: No connection

Disassembly Procedures

1 Removing the top cover

- (1) Remove the 2 screws on both sides of the top cover and the 4 screws on the rear side.
- (2) Gently spread both sides of the top cover to the outside, lift up the rear section, and remove the top cover.

2 Removing the tray

- (1) Remove the top cover.
- (2) Switch on the power of AX-MX70BK.
Press the OPEN / CLOSE switch to bring the tray forward and with the tray forward, switch off the power.

- (3) Remove the screw on the tray ②.
- (4) Pull the tray toward the front to move it.

Note : If the power does not come on due to breakdown or the , insert a Philips screwdriver through the hole at the bottom of the front panel and turn it clockwise to bring the tray forward ①.

3 Removing the front panel assembly

- (1) Remove the top cover.
- (2) Remove the connectors(J991 , J992 , J993) connecting with main PC Boards.
- (3) Remove the 3 screws ③ at the bottom of the front panel.

4 Removing the mechanism assembly

- (1) Remove the top cover.
- (2) Remove the tray.
- (3) Remove the connectors (P993 , P994).
- (4) Remove the 2 screws ② holding the clamp assembly, then remove it.
- (5) Remove the 3 screws ① holding the mechanism assembly.

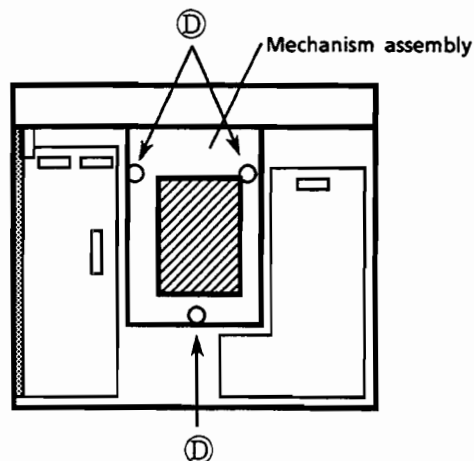
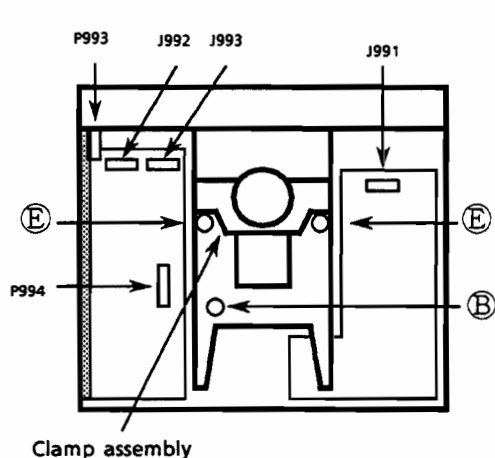
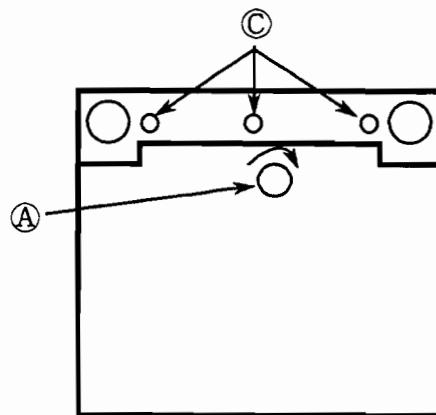

6. Removing the Laser Pickup

- (1) Remove the top cover, tray assembly and the clamp.
- (2) Move the Pickup Unit from rest position to the center pushing ⑤ point with finger.
- (3) Remove the screw ② from the CD RACK assembly, and remove the CD RACK assembly.
- (4) Remove the screw ① from the mechanical base assembly.
- (5) Remove the CD HOLDER fastening the shaft from the mechanical base assembly. (Release the hook ⑥)
- (6) Remove the CD Pick Unit with the shaft.

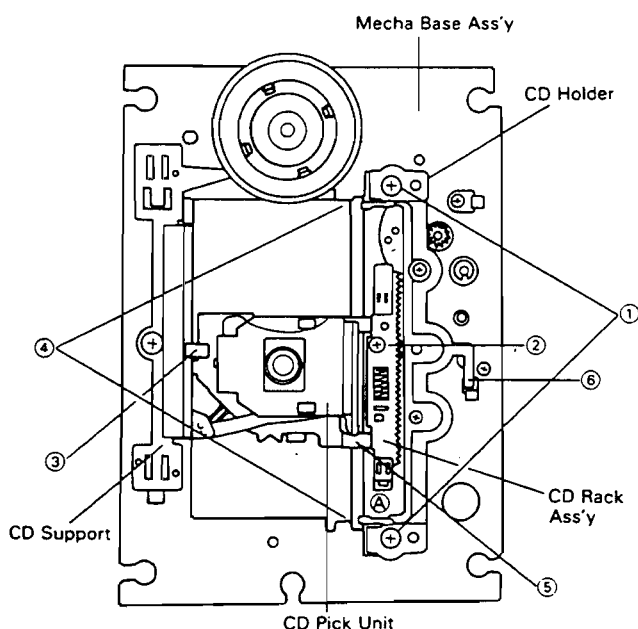

7. Laser Pickup installation

- (1) Connect two wires with the connectors of P.C. Board.
- (2) While installing the ③ in the CD Support, set the shaft on the base hook ④.
- (3) Install the CD Holder.
- (4) Install THE CD Rack assembly in CD Pick Unit.
 - 1) Fit end ①
 - 2) Fix screw ②.

8. Spindle motor removal

- (1) Remove the Mechanism assembly.
- (2) Remove the Clamp assembly.
- (3) Remove the turntable, and remove the two screws retaining the spindle motor.
- (4) Remove the screw retaining the Spindle and Feed Motor P.C. Board and unsolder it.

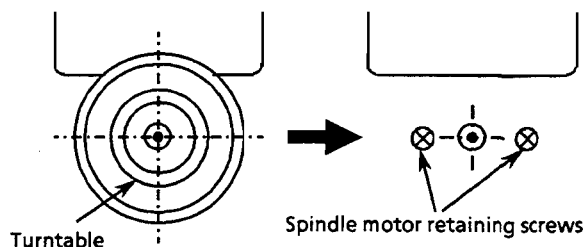

9. Spindle motor installation

- (1) Tighten the 2 screws to the same torque.
- (2) Fasten the Spindle and Feed Motor P.C. Board with the screw and solder.
- (3) Install the turntable. When installing, press straight down at the center of the turntable until the distance from the surface of the mechanism base to the top of the turntable is exactly $12.0 \pm 0.1\text{mm}$.

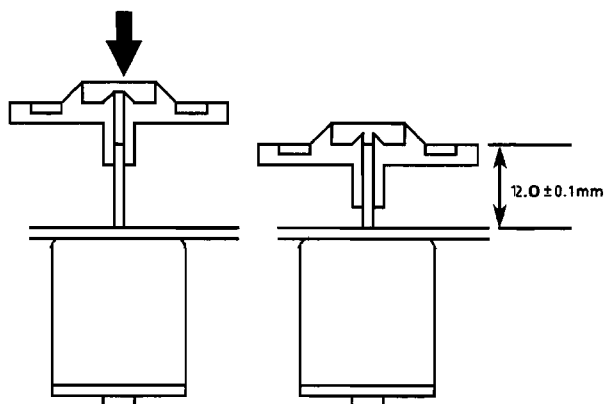

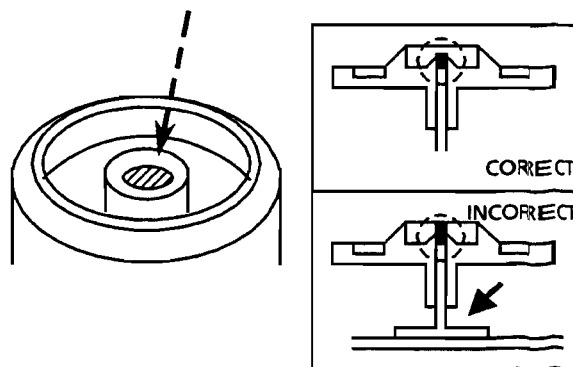

- (4) After insertion is complete, bond the motor shaft and turntable together (at the section marked by an arrow in the figure on the left below).



- (5) Use "LOCKTITE" #460 bonding agent and apply as little as possible. Take care not to allow any excess bonding agent to get onto the turntable. Be extremely careful not to allow bonding agent to adhere to the motor bearings (the section marked by an arrow in the figure on the right.)

Application Points for Grease

Grease used

-  G-334 (Shin-Etsu Chemical Co., Ltd.)
-  G-474C (Kanto Chemical Co., Ltd.)
-  G-31KB (Kanto Chemical Co., Ltd.)

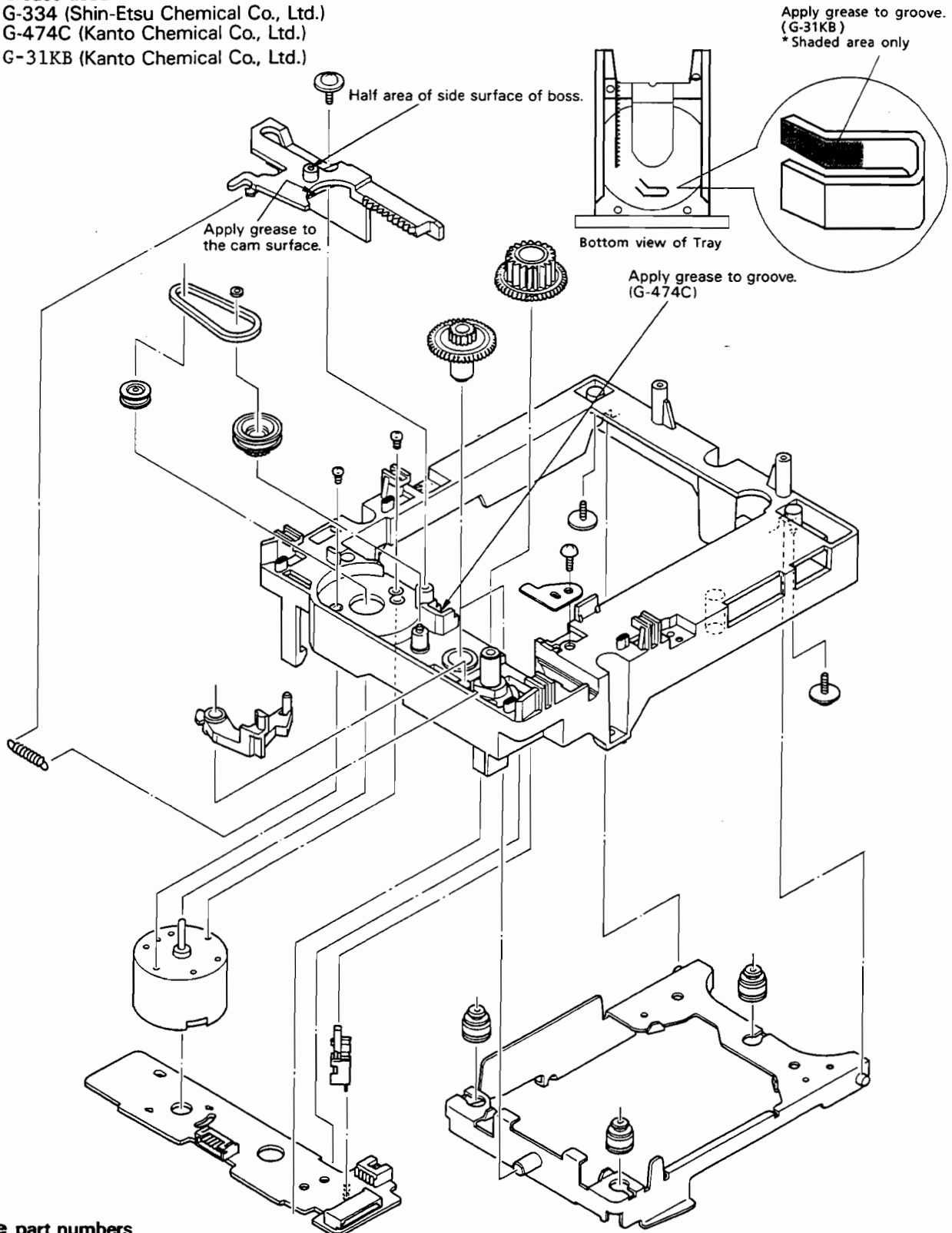

- Grease part numbers**
G-334: EBS0006-009B
G-474C: EBS0006-019B
G-31KB: EBS0006-013B

Maintenance of Laser Pickup

1. Life of the laser diode

When the life of the laser diode has expired, the following symptoms will appear.

- (1) The level of RF output (EFM output: amplitude of eye pattern) will be low.
- (2) The drive current required by the laser diode will be increased.

In such a case, check the life of the laser diode following the flowchart below

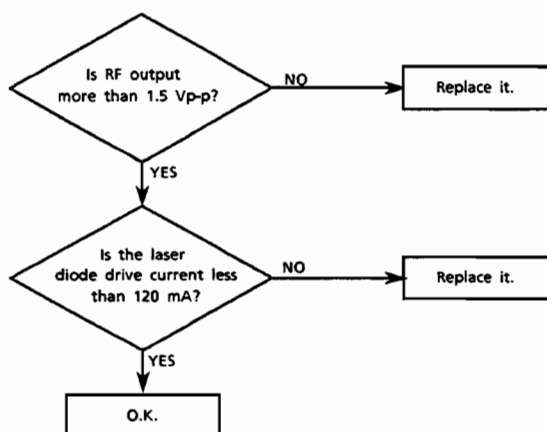

2. Measurement of laser diode drive current

Replace the jump wire (W908) shown below with the resistor (1Ω).

Measure the voltage across the resistor with a milli-voltmeter. When the voltage is more than 120mV, it shows that the life of the laser diode has expired

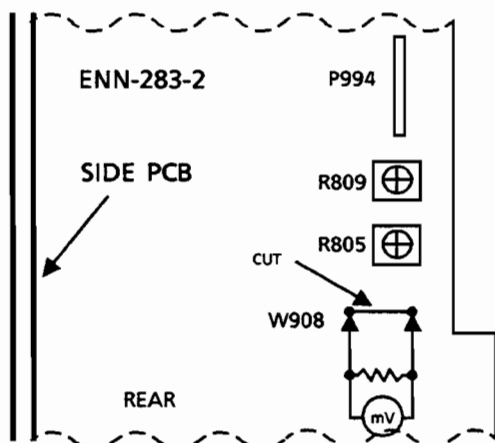

3. Semi-fixed resistor on the APC PC board

The semi-fixed resistor on the APC printed circuit board which is attached to the pickup is used to adjust the laser power. Since this adjustment should be performed to match the characteristics of the whole optical block, do not touch the semi-fixed resistor.

If the laser power is lower than the specified value, the laser diode is almost worn out, and the laser pickup should be replaced.

If the semi-fixed resistor is adjusted while the pickup is functioning normally, the laser pickup may be damaged due to excessive current.

Replacement of Laser Pickup

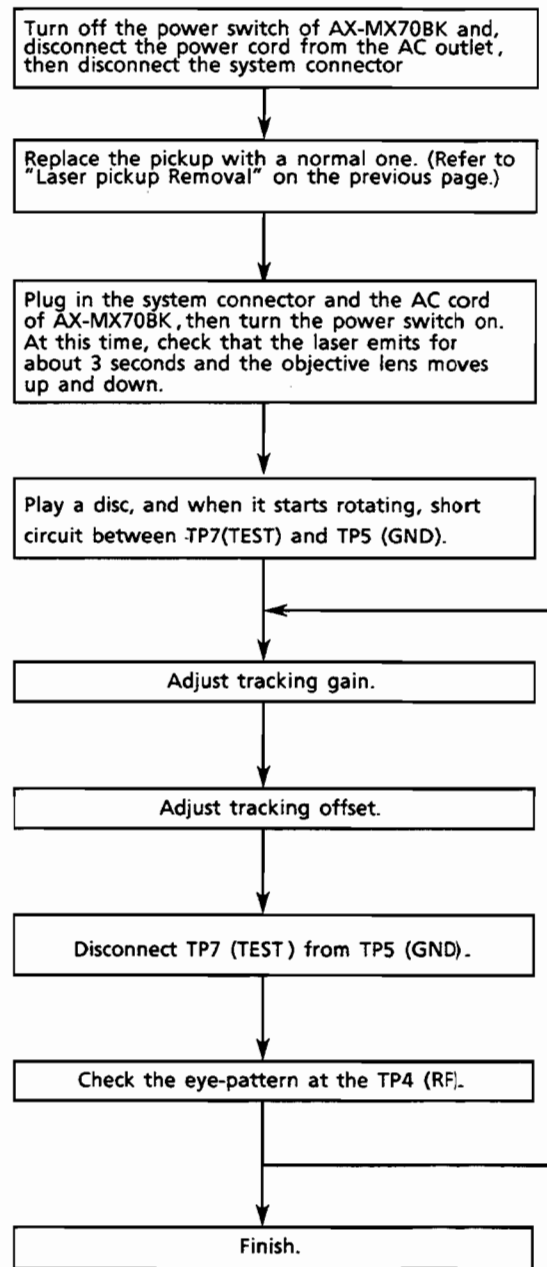

Note: Since one adjustment may affect other settings, repeat these adjustments a few times.

Flow of Functional Operation Until TOC is Read

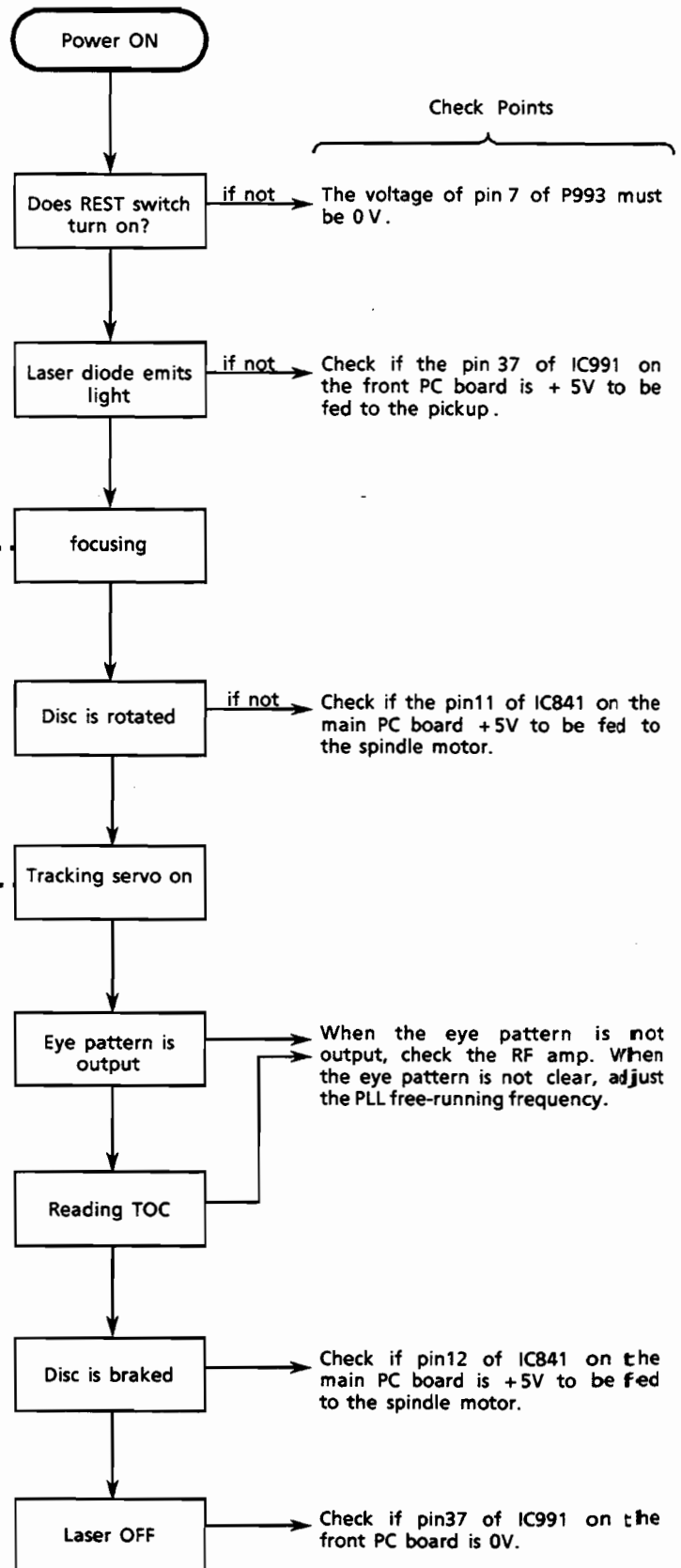
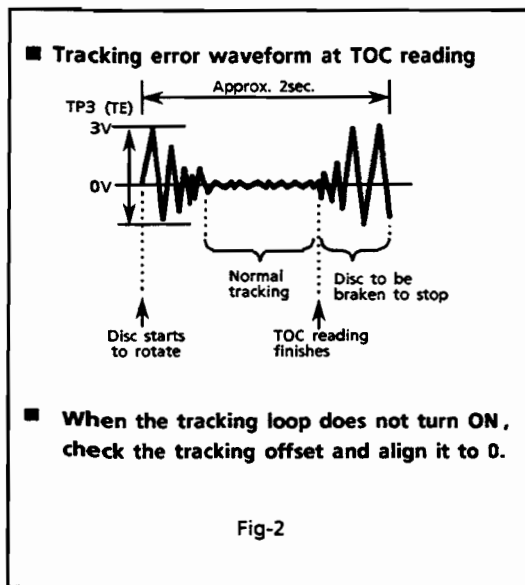
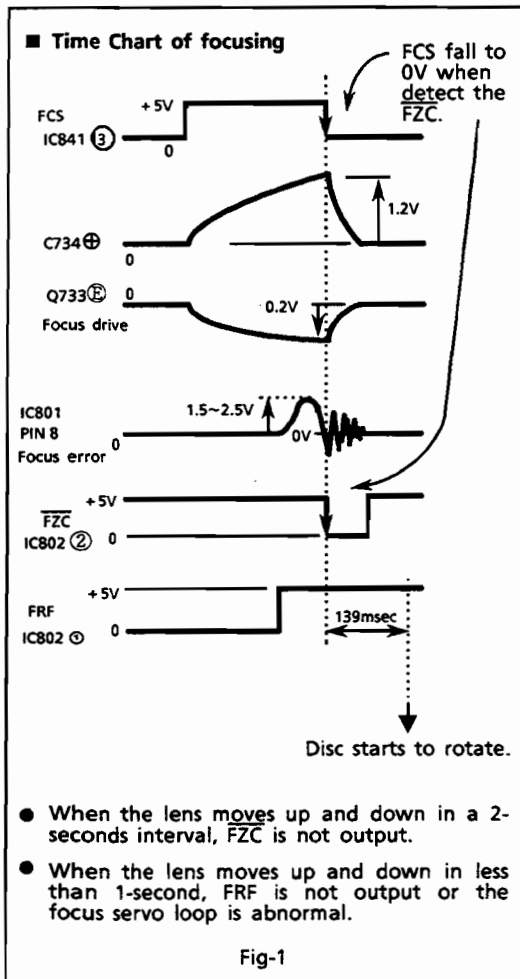

Adjustment Procedures

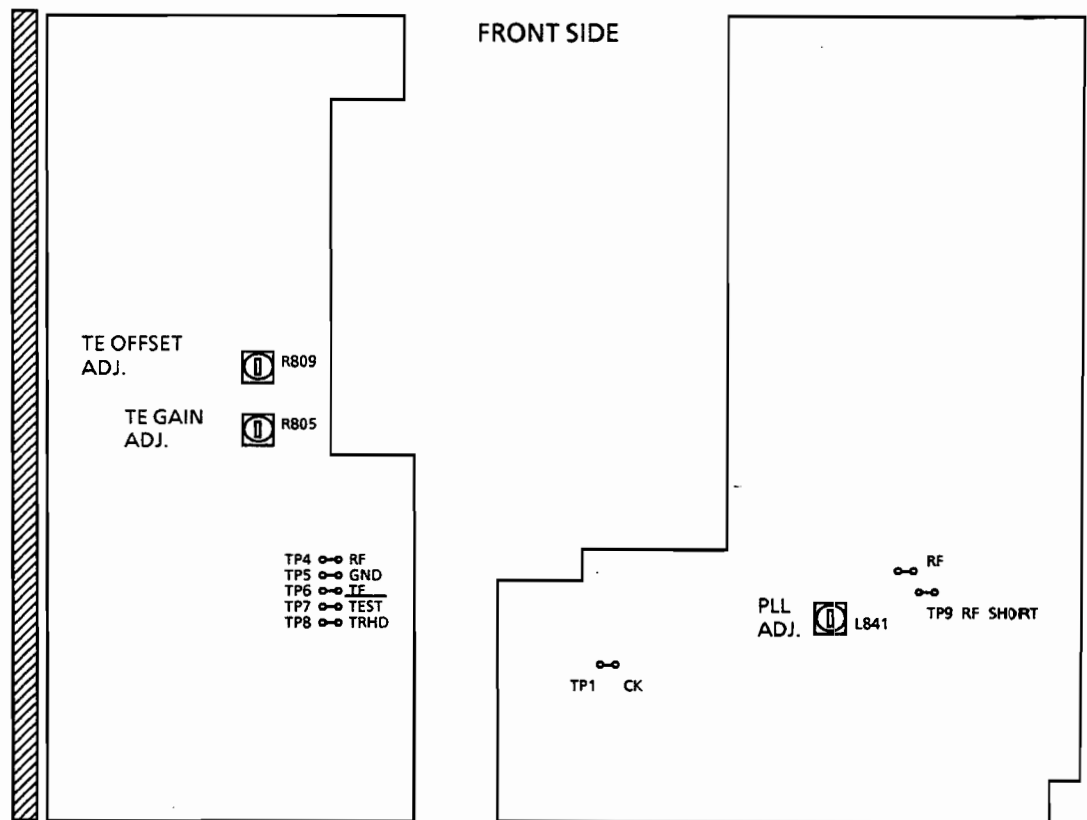

*** Use AX-MX70BK when adjusting .**

1. PLL free-running adjustment

- 1) Measuring instrument
Frequency counter
- 2) Adjusting procedure
 - (1) Connect a frequency counter with TP1 (CK) and TP5 (GND) on the main PC board . Short circuit TP9 to TP5(GND) .
 - (2) Adjust L841 for setting the frequency counter's value becomes $4.320 \pm 0.005\text{MHz}$.

2. Tracking gain adjustment

- 1) Measuring instruments
Oscilloscope, Normal disc
- 2) Adjusting procedure
 - (1) Connect an oscilloscope with TP6 (TE) and TP5 (GND) on the main PC board.
 - (2) Play a disc.
 - (3) Short circuit TP7 (TEST) to TP5 (GND).
 - (4) Adjust R805 for setting tracking error signal becomes $2.0 \text{ V}_{\text{p.p.}}$.

3. Tracking offset adjustment

- 1) Measuring instruments
Oscilloscope, Normal disc
- 2) Adjusting procedure
 - (1) Connect an oscilloscope with TP6 (TE) and TP5 (GND) on the main PC board.
 - (2) Play a disc.
 - (3) Short circuit TP7 (TEST) to TP5 (GND).
 - (4) Adjust R809 for setting the DC level of the tracking error (off set) becomes 0.

Troubleshooting

The following shows the status of the various circuits from turning on the power to start of disc play .

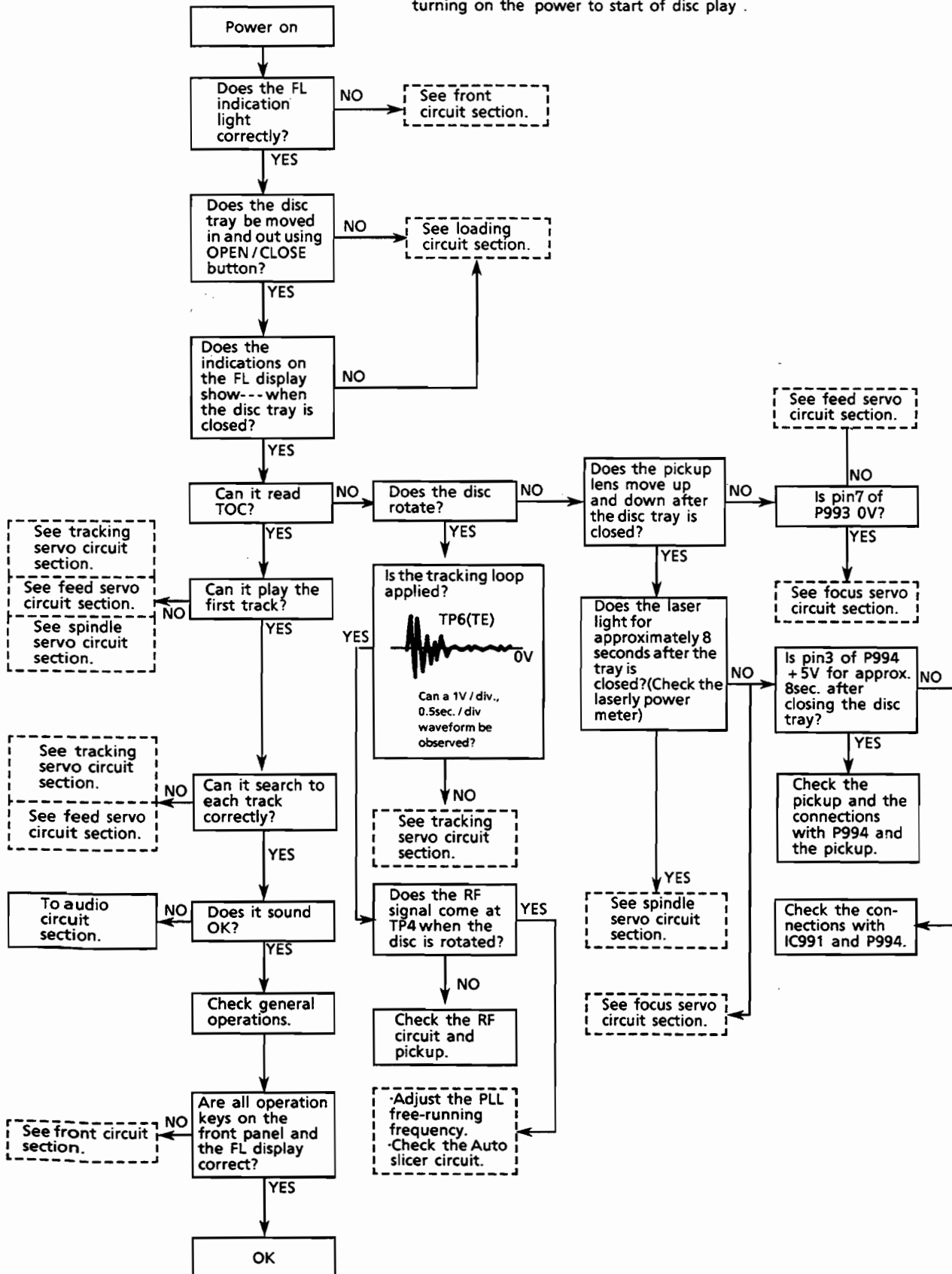

Front circuit Section

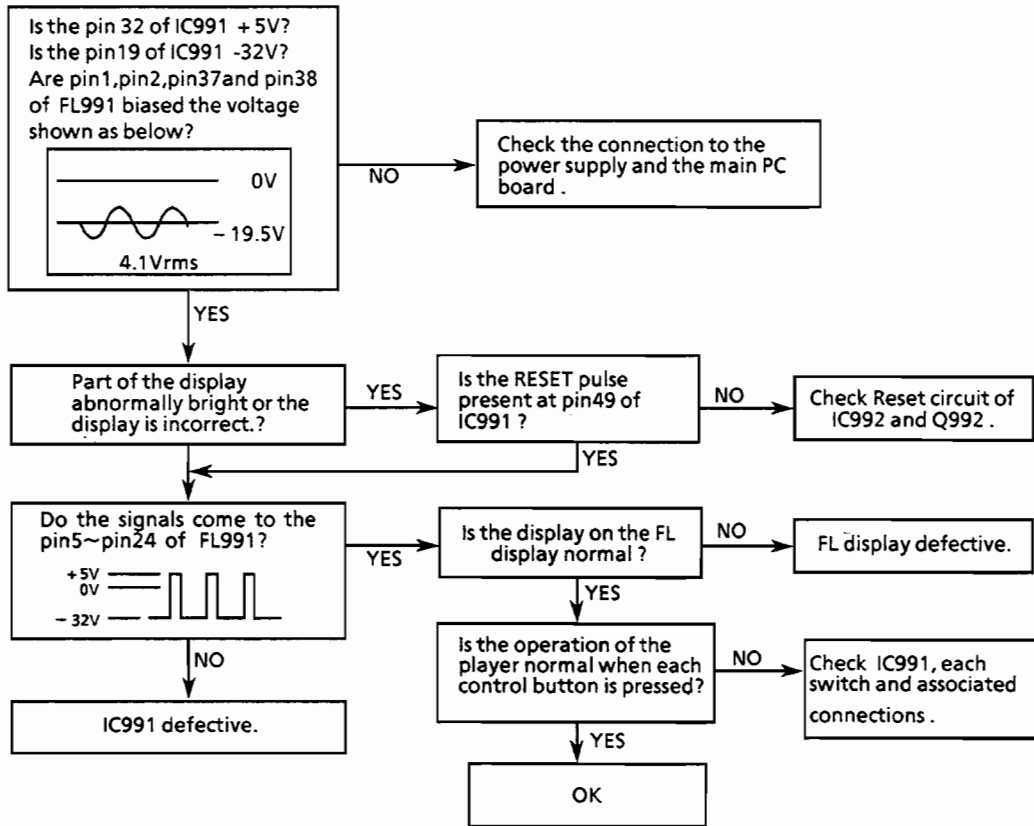

Loading circuit section

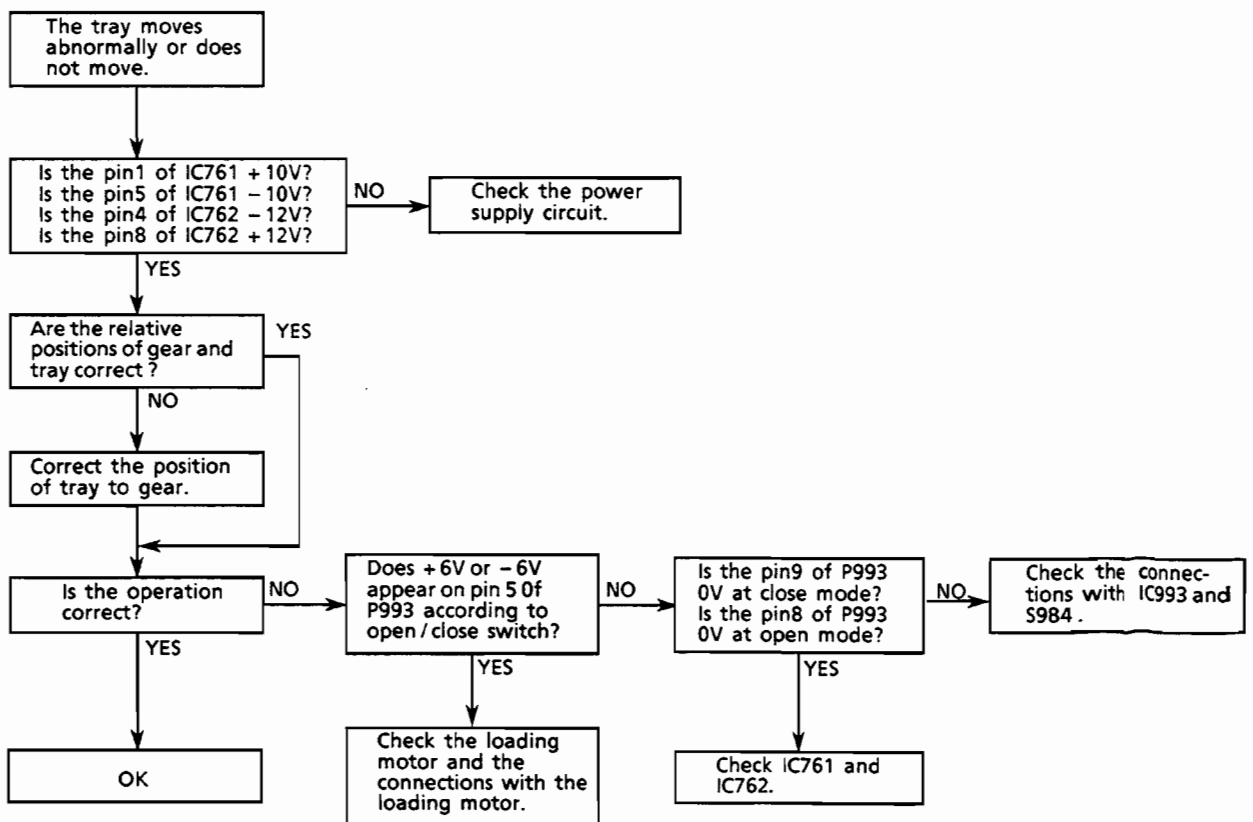

XL-MX70BK

Focus circuit section

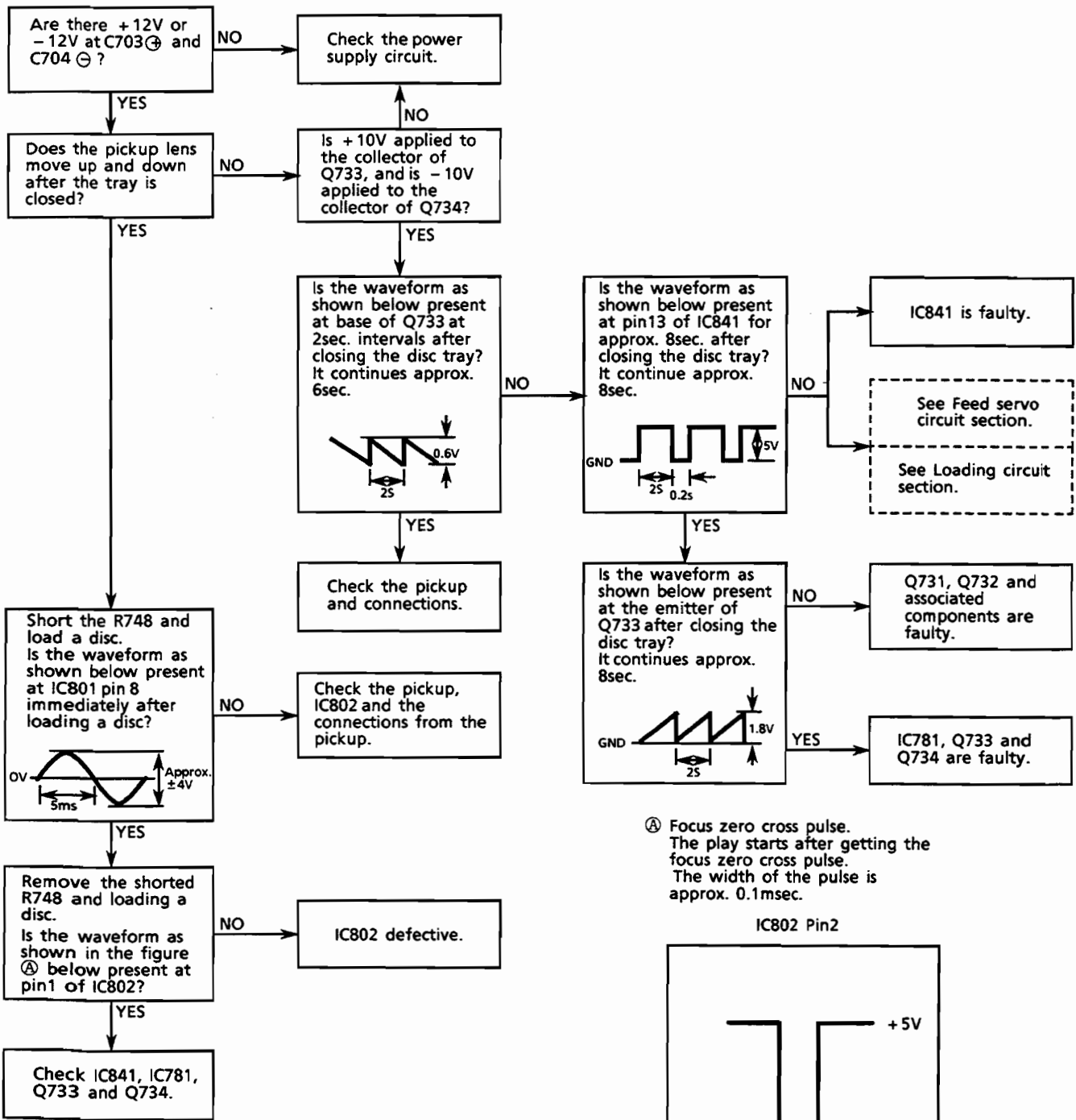

Tracking circuit section

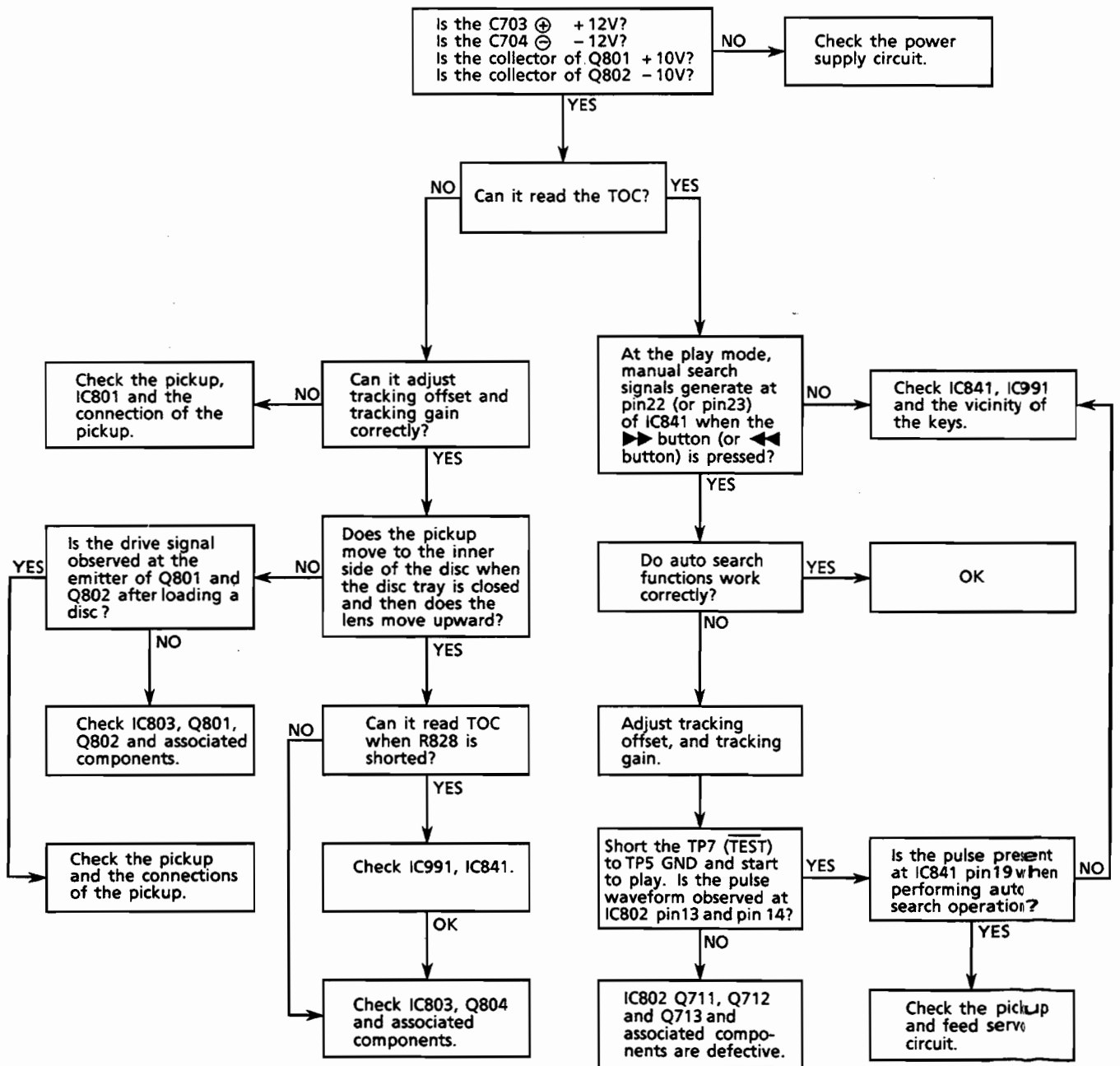

XL-MX70BK

Feed circuit section

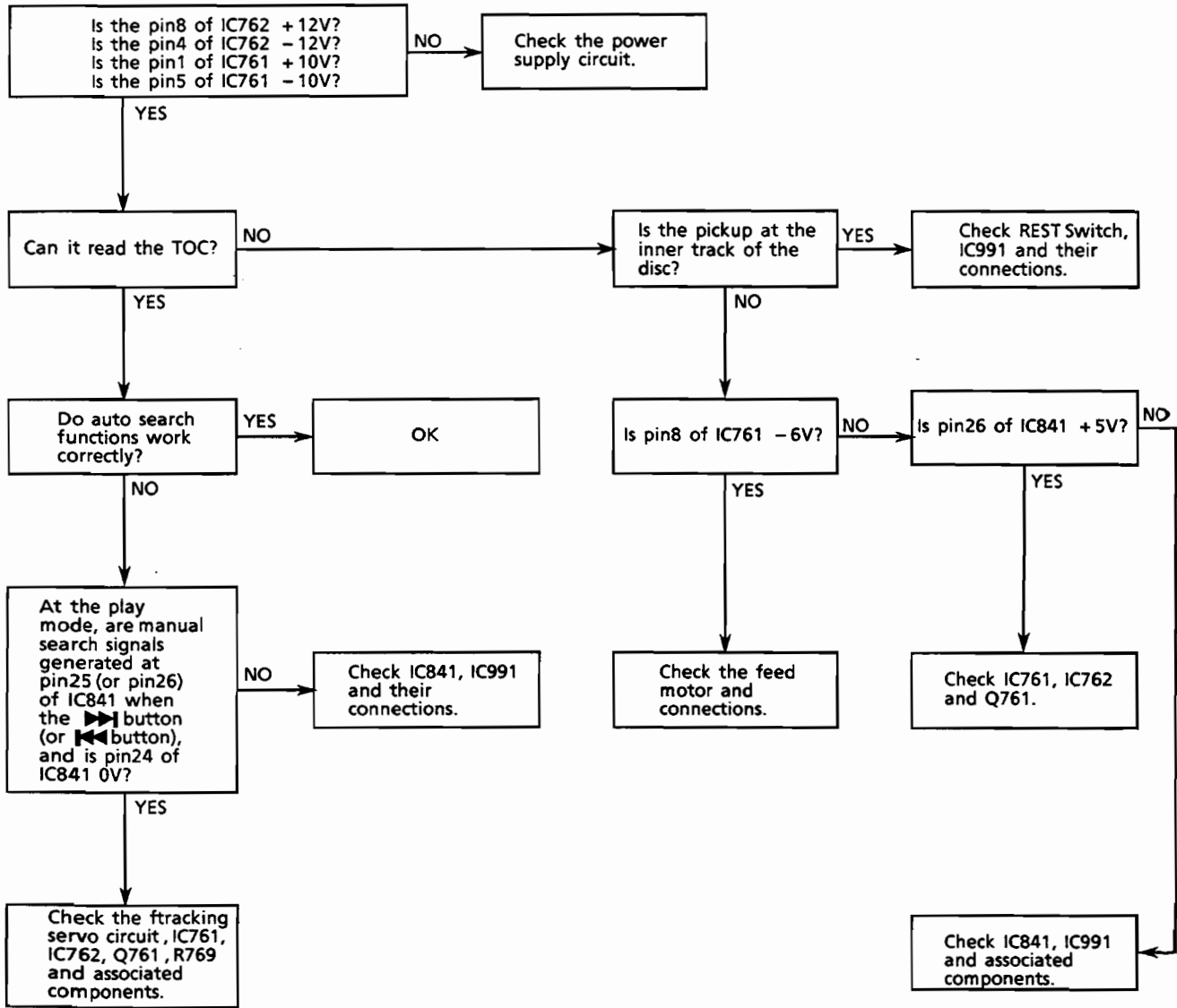

Spindle circuit section

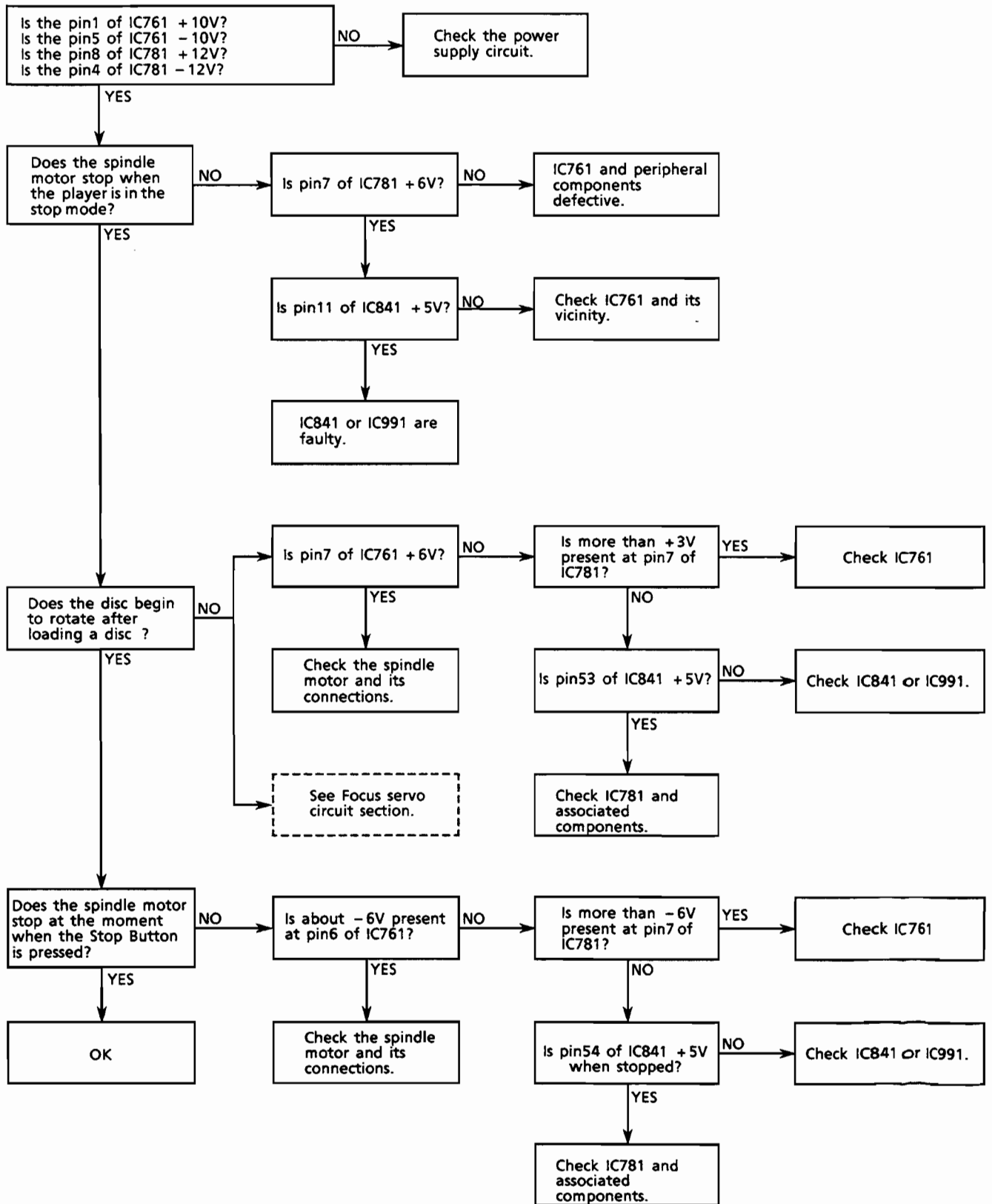

Connection Diagram

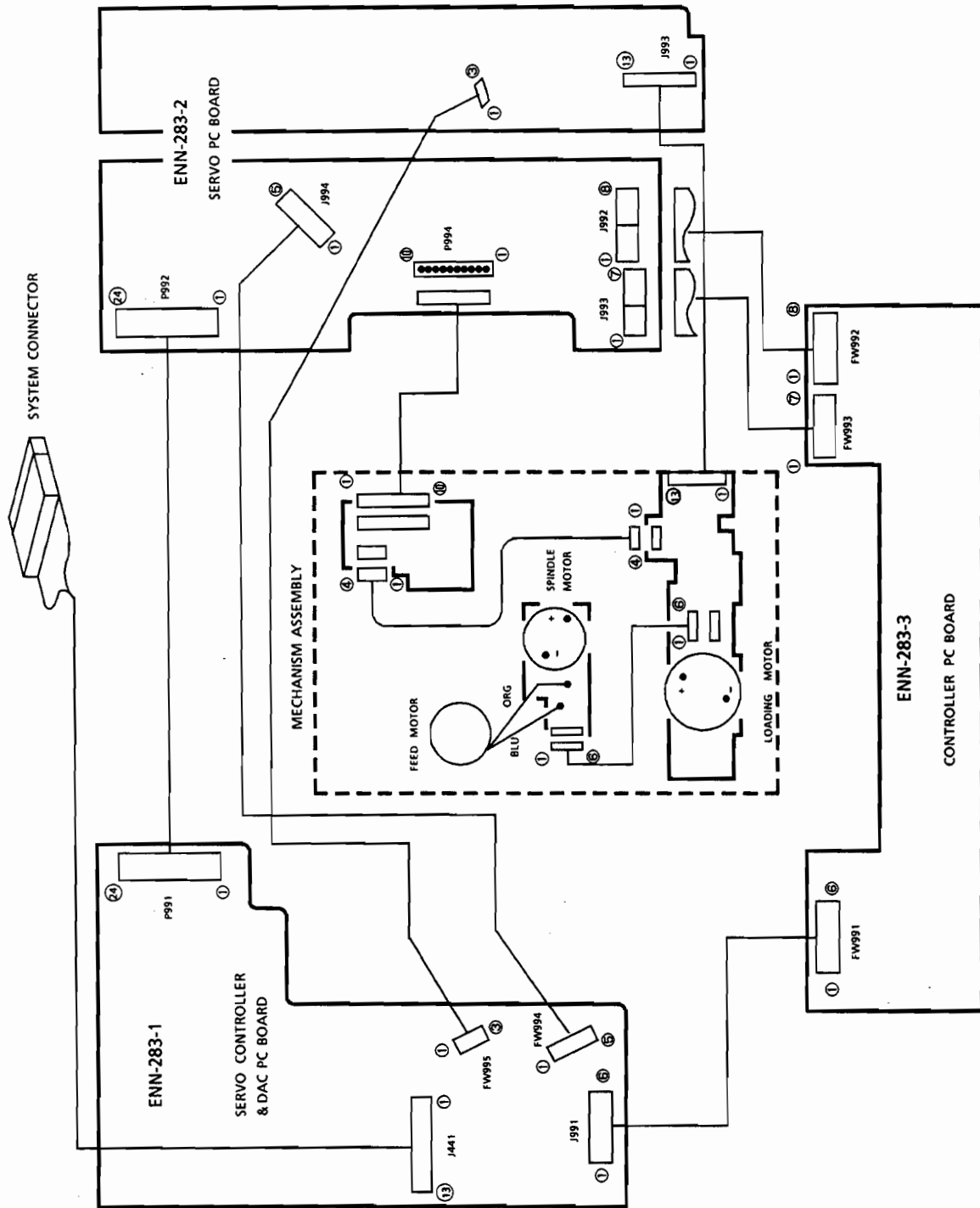

Block Diagram

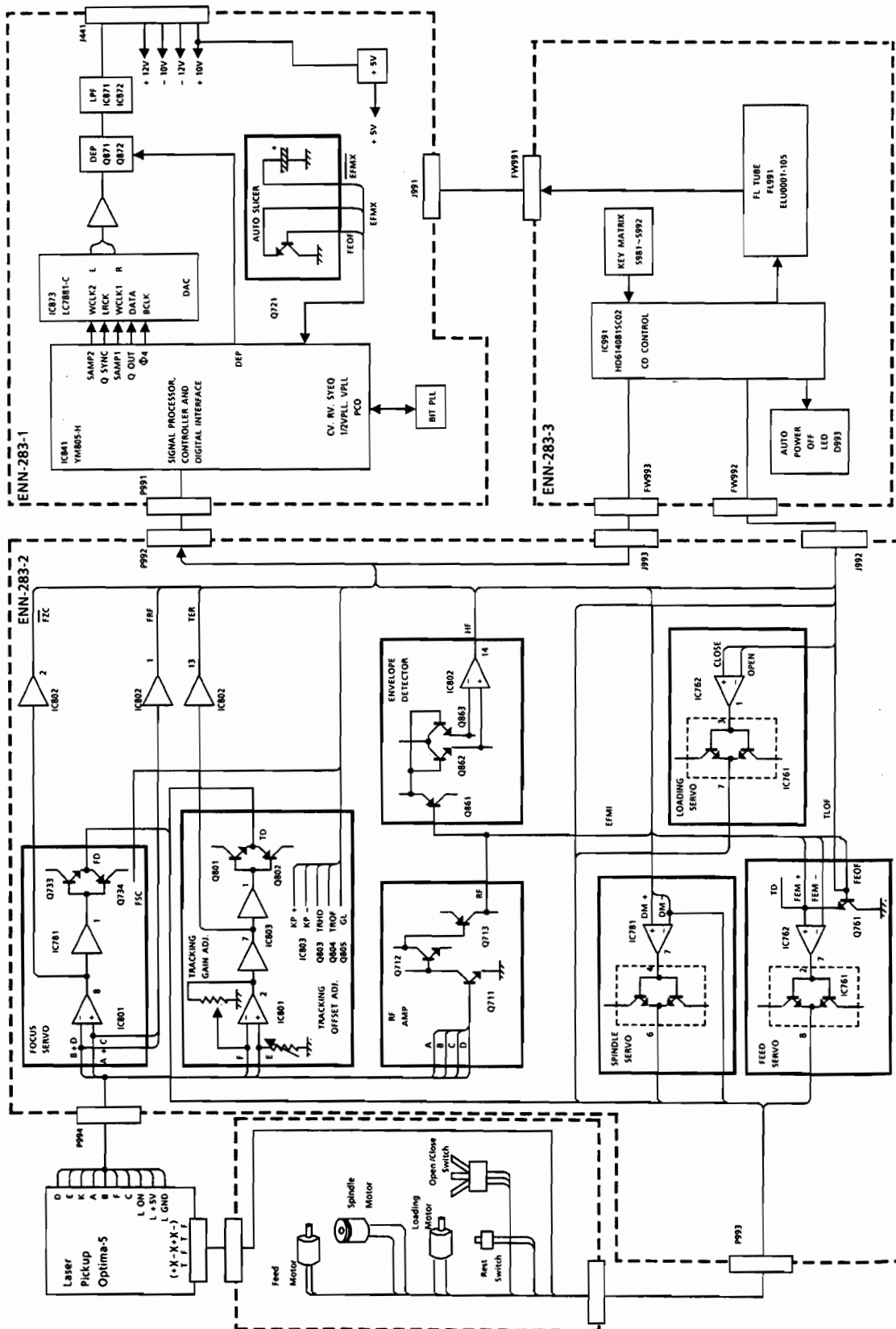

Schematic Diagram

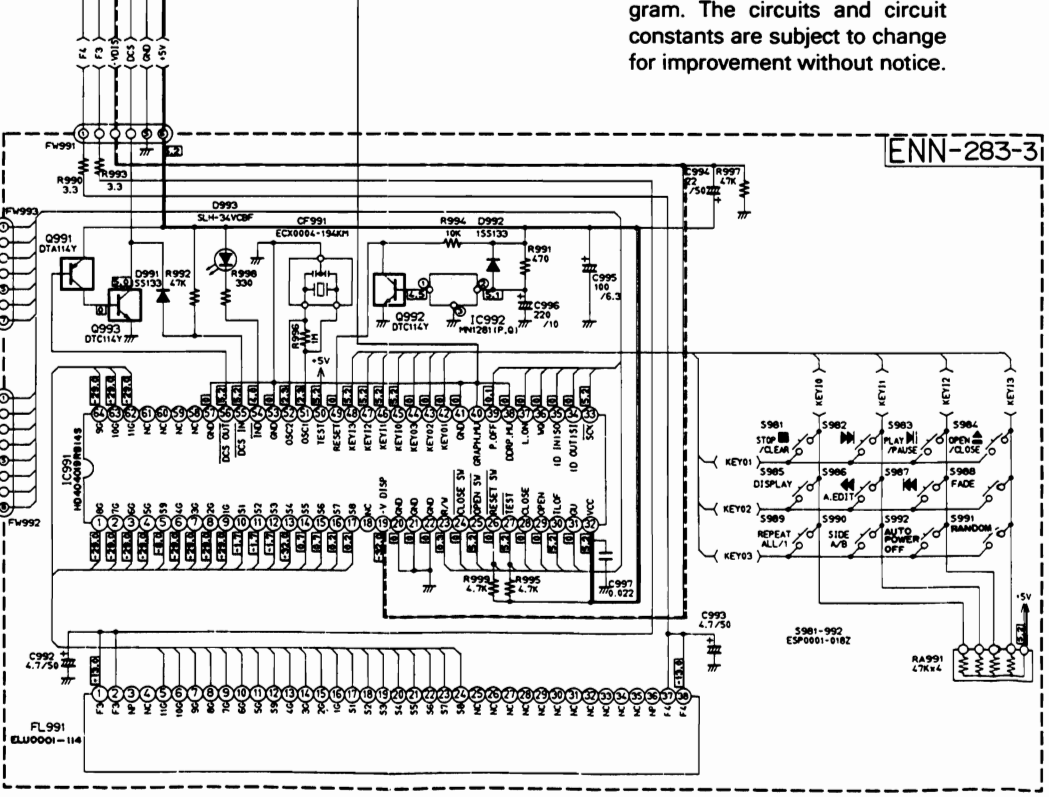
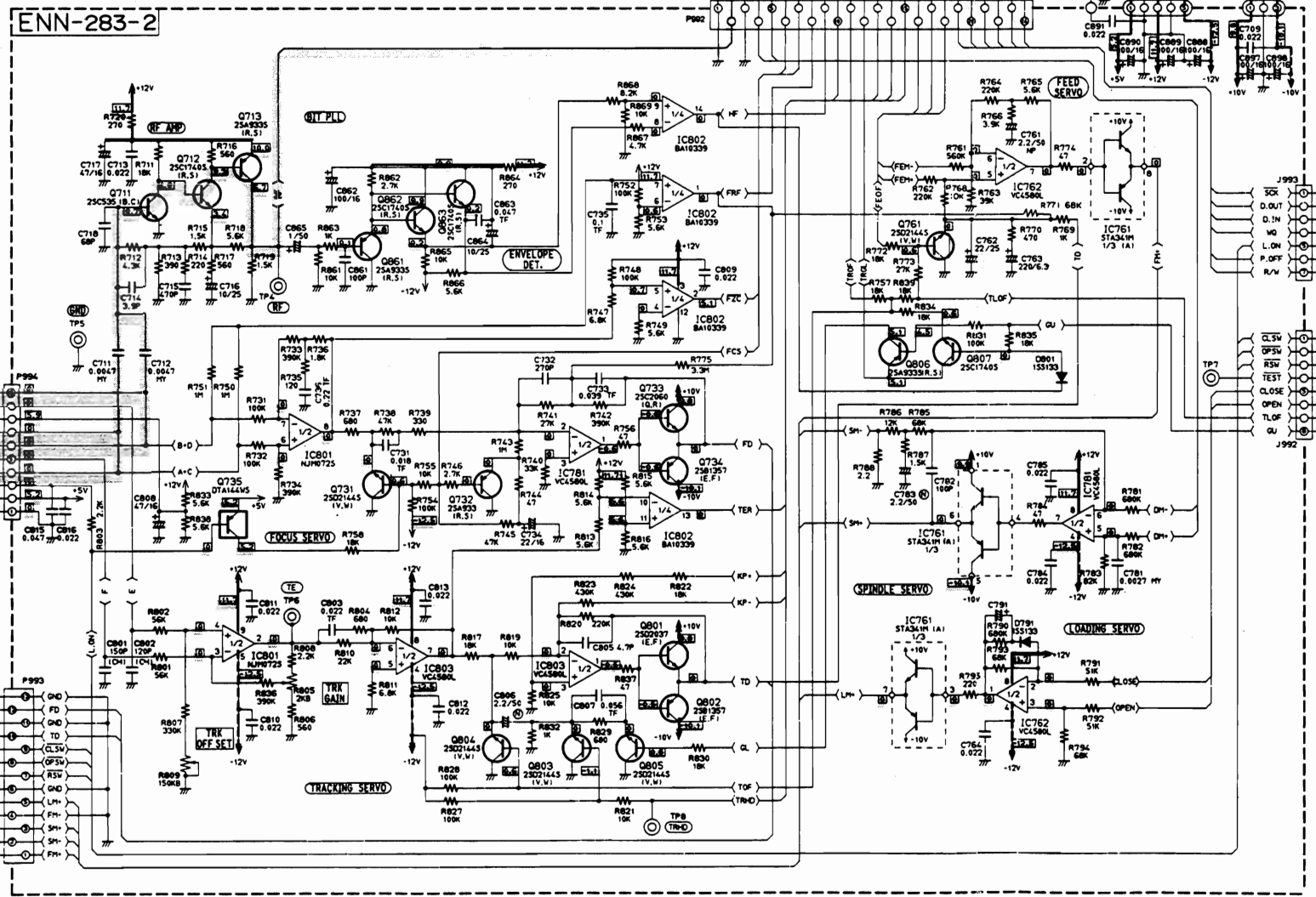
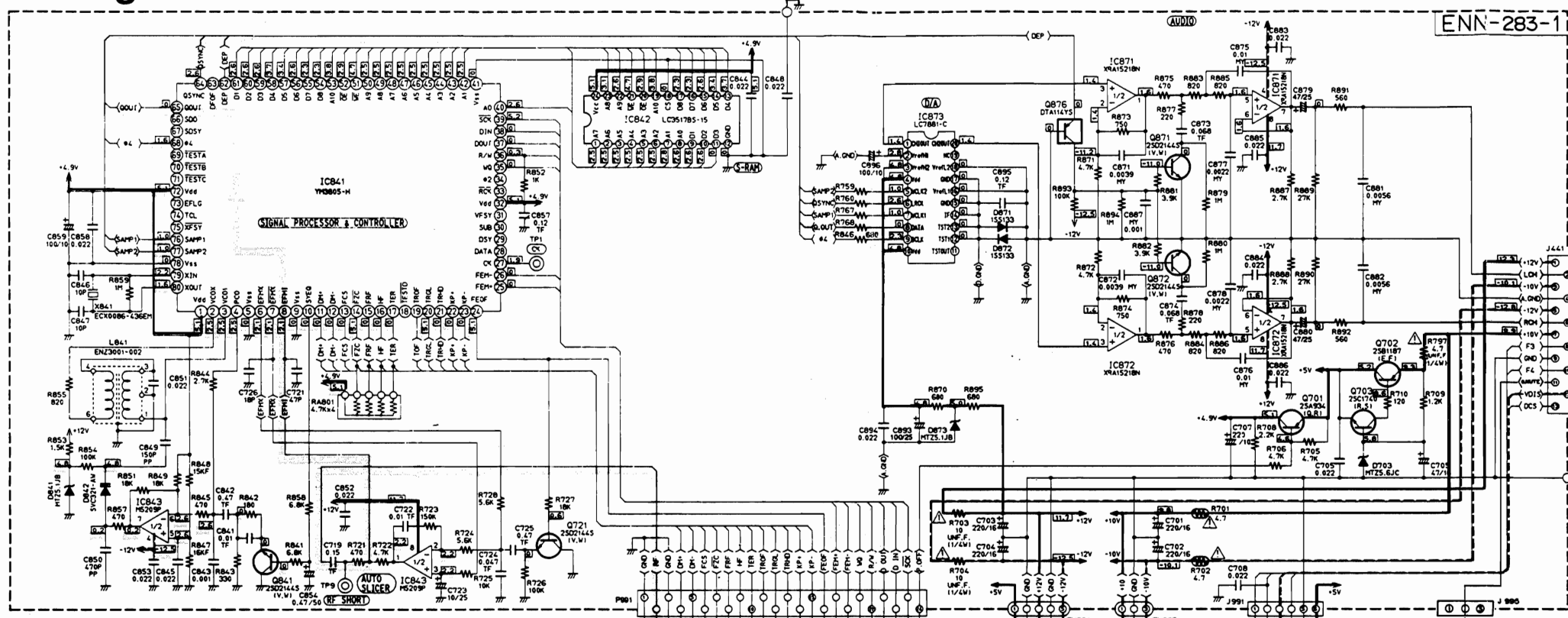

How to Use Schematic Diagrams

1. — indicates the +B line.
2. - - - indicates the -B line.
3. □ indicates signal path.
4. □ indicates voltage value.
5. Parts marked with Δ and those in the shaded area are parts for safety. Be sure to use one with the specified part number.
6. This is the standard circuit diagram. The circuits and circuit constants are subject to change for improvement without notice.

PARTS LIST

Contents

General Exploded View and Parts List	2-2
CD Mechanism Ass'y and Parts List	2-4
Printed Circuit Board Ass'y and Parts List	2-6
■ENN-283 □ Main PC Board Ass'y	2-6

General Exploded View and Parts List

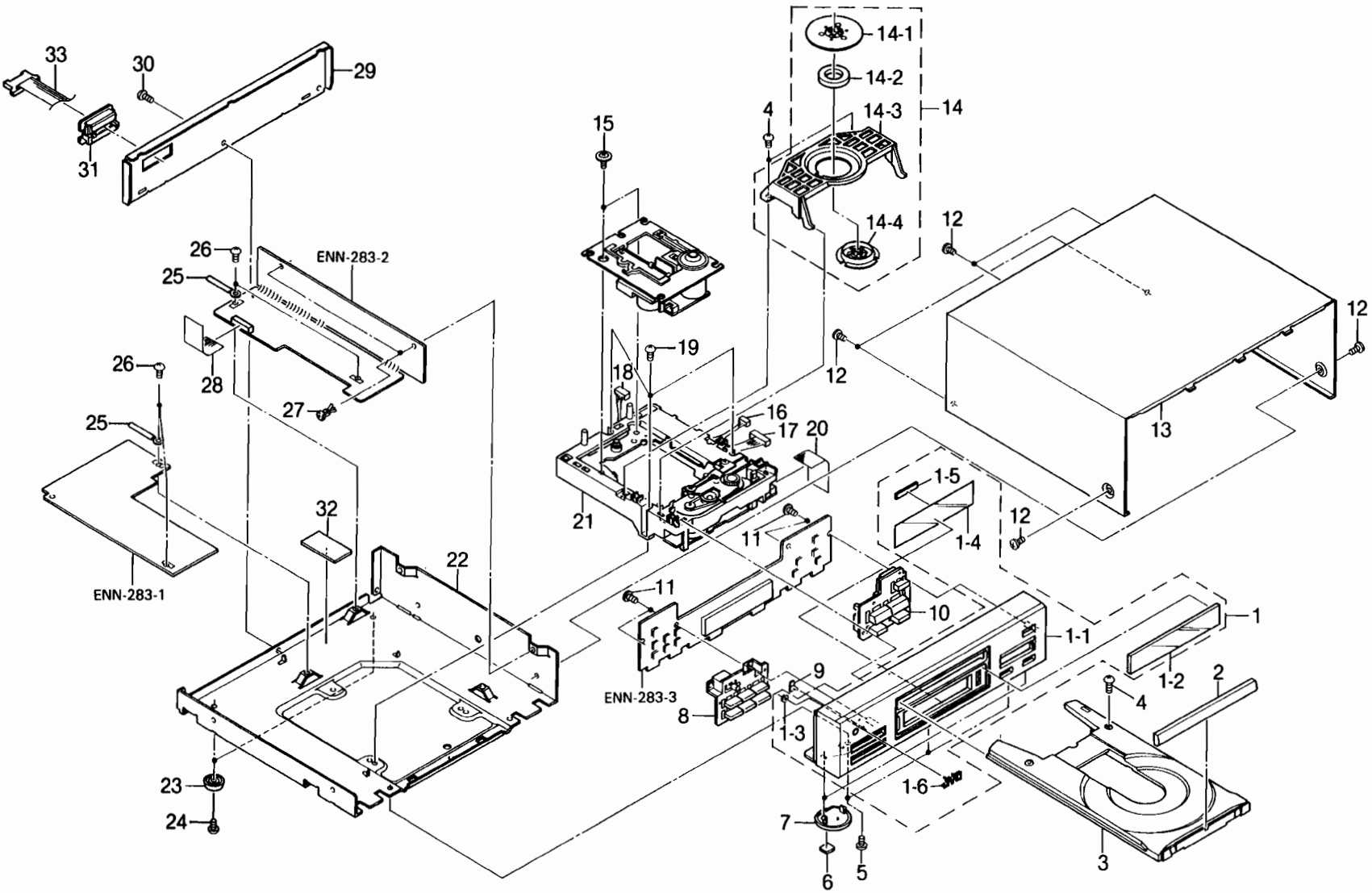

■ Parts List

△	Item	Part Number	Part Name	Q'ty	Description	Areas
	1	EFP-XLMX70BKE (S	Front Panel Ass'y	1		
	1-1	E102328-005	Front Panel	1		
	1-2	E306949-003	Window Screen	1		
	1-3	E60912-003	Speed Nut	1		
	1-4	E70561-027	FL Screen	1		
	1-5	EXO035003R10S13	Spacer	1		
	1-6	PQ42561	JVC Mark	1		
	2	E306947-003	Fitting	1		
	3	E12289-005	Tray	1		
	4	SBSF3008M	Screw	3		
	5	SDSG3006M	Screw	3		
	6	E75896-001	Spacer	2	for Foot (Front)	
	7	E306935-001	Foot	2	Front	
	8	E306943-002	Push Button	1	POWER	
	9	E406091-001	Indicator	1		
	10	E306945-002	Push Button	1	CD PLAY	
	11	SDSF2608Z	Screw	4		
	12	SDSG3008M	Screw	6	for Metal Cover	
	13	E206817-001	Metal Cover	1		
	14	E306837-003	Clamper Base Ass'y	1		
	14-1	E306836-003	Yoke	1		
	14-2	E74897-002	Magnet	1		
	14-3	E26756-001	Clamper Base	1		
	14-4	E306835-001	Clamper	1		
	15	E75871-003	Special Screw	2		
	16	EWS254-B103	Socket Wire Ass'y	1	4PIN	
	17	EWS25A-B102	Socket Wire Ass'y	1	10PIN	
	18	EWS256-B102	Socket Wire Ass'y	1	6PIN	
	19	SBST3006Z	Screw	3		
	20	EWR1DE-10TT	Flat Cable	1	13PIN	
	21	—————	CD Mechanism Unit Ass'y	1	See page 2-4	
	22	E102330-001	Chassis Base	1		
	23	E47227-023	Foot	2	Rear	
	24	SBSG3008N	Screw	2	for Foot	
	25	E72018-001	Wire Clamp	2		
	26	SBSG3008CC	Screw	4		
	27	E48729-008	Plastic Rivet	2		
	28	EWR1QE-11TT	Flat Cable	1	24PIN	
	29	E206815-008	Rear Panel	1		J
		E206815-009	Rear Panel	1		C, A, U
	—	E206815-010	Rear Panel	1		E, EF, G, BS, GI
	30	E307534-001	Rating Label	1		J
	31	SBSG3008M	Screw	1		
	32	E305920-001	Cord Holder	1		
	32	E306805-027	Spacer	1		
	33	EWP902-020	Plug Cord Ass'y	1	JB441	
	—	E406507-001	Caution Label	1		Except J
	—	E61029-009	Number Label	1		Except J
	—	E70891-001	Class 1 Label	1		Except J, C

The Marks for Designated Areas

△ Safety Parts

J.....the U.S.A. BS.....the U.K.
 C.....Canada GI.....Italy
 A.....Australia U.....Universal Type
 E,EF.....Continental Europe No mark indicates all areas.
 G.....Germany

CD Mechanism Ass'y and Parts List

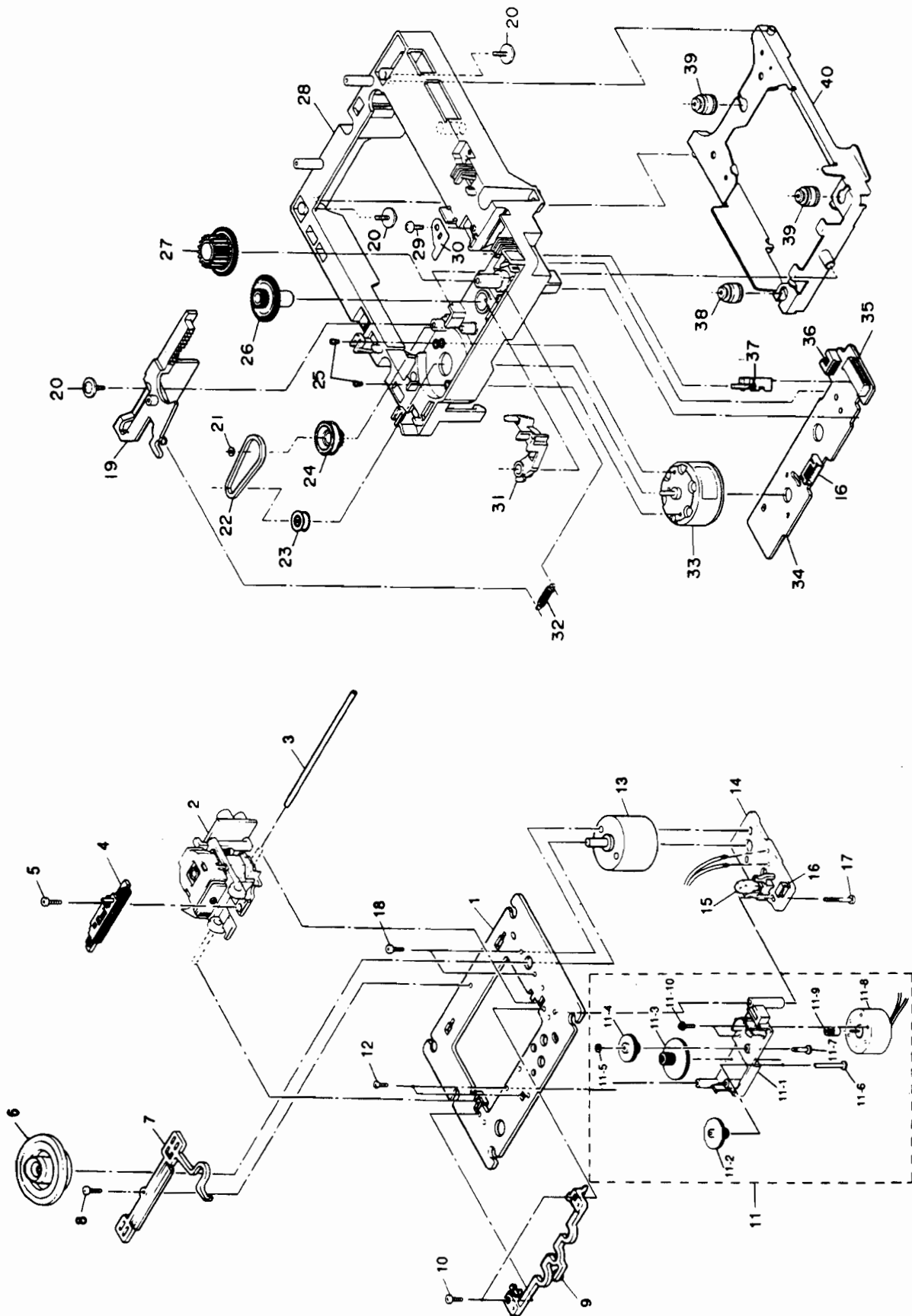

■ Parts List

Item	Part Number	Part Name	Q'ty	Description	Areas
1	E26487-003	Mechanism Base	1		
2	OPTIMA-5S	Pick up Ass'y	1		
3	E74930-003	Shaft	1		
4	E306282-001	Rack Ass'y	1		
5	SPSH2050M	Screw	1		
6	E406064-002	Turn Table Ass'y	1		
7	E306275-003	Support	1		
8	SDST2005Z	Screw	1		
9	E306277-001	Holder	1		
10	SDST2004Z	Screw	2		
11	SE10351-11	Gear Ass'y	1		
11-1	E306276-001	Gear Base	1		
11-2	E75444-001	Gear	1		
11-3	E75443-001	Gear	1		
11-4	E75445-001	Gear	1		
11-5	WDM163550	Slit Washer	1		
11-6	E75494-003	Shaft	2		
11-7	E75494-002	Shaft	1		
11-8	HKN-3A6RDNV	Feed Motor	1		
11-9	E75493-001	Pinion Gear	1		
11-10	LPSH1735Z	Screw	2		
12	E72713-001	Special Screw	2		
13	E74539-001B	Spindle Motor	1		
14	E12114-005 (S)	Circuit Board	1		
15	ESB1100-005	Leaf Switch	1	S001	
16	EMV5109-006B	6P Plug Ass'y	2	P011	
17	E75832-001	Special Screw	1		
18	SDSP2003N	Screw	2		
19	E306834-001	Cam	1		
20	E65923-003	Special Screw	3		
21	E72024-001	Speed Nut	1		
22	E75950-002	Belt	1		
23	E75984-001	Motor Pulley	1		
24	E75985-001	Gear (1)	1		
25	SPSK2640Z	Screw	2		
26	E75986-002	Gear (2)	1		
27	E75987-001	Gear (3)	1		
28	E12288-002	Loading Base	1		
29	SBSF3008Z	Screw	1		
30	E75988-001	Plate	1		
31	E306833-001	Lever	1		
32	E75989-001	Spring	1		
33	RF-500TB-12560	Loading Motor	1		
34	EMW10045-001 (S)	Circuit Board	1		
35	EMV7123-013R	Connector	1	13PIN	
36	EMV5109-004B	Plug Ass'y	1	4PIN	
37	ESS1200-002	Switch	1		
38	E75609-002	Insulator	1		
39	E75609-001	Insulator	2		
40	E307087-001	Elevator Base Ass'y	1		

Printed Circuit Board Ass'y and Parts List

■ ENN-283 □ Main PC Board Ass'y

Note : ENN-283 □ varies according to the areas employed. See note (1) when placing an order.

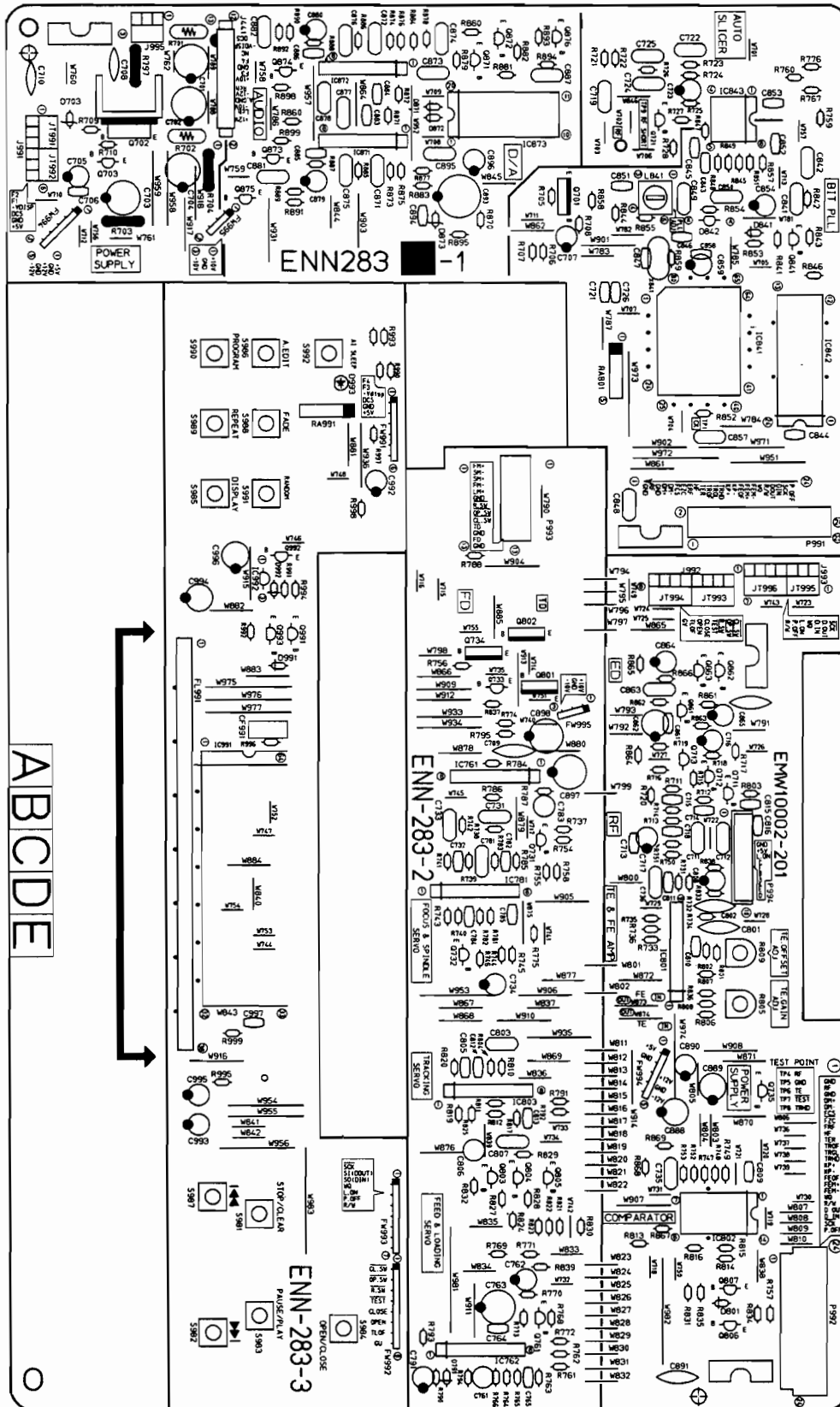

Note (1)

PC Board Ass'y	Designated Areas
ENN-283 A	the U.S.A. , Canada
ENN-283 B	Australia, the U.K. Continental Europe Universal Type
ENN-283 C	Germany , Italy

Transistors

ITEM	PART NUMBER	DESCRIPTION	AREA
Q701	2SB1357(E,F)	SILICON ROHM	
Q702	2SB1187(E,F)	SILICON ROHM	
Q703	2SC1740(R,S)	SILICON ROHM	
Q711	2SC535(B,C)	SILICON HITACHI	
Q712	2SC1740S(R,S)	SILICON ROHM	
Q713	2SA933S(R,S)	SILICON ROHM	
Q721	2SD2144S(VW)	SILICON ROHM	
Q731	2SD2144S(VW)	SILICON ROHM	
Q732	2SA933S(R,S)	SILICON ROHM	
Q733	2SC2060(Q,R)	SILICON ROHM	
Q734	2SB1357(E,F)	SILICON ROHM	
Q735	DTA144WS	SILICON ROHM	
Q761	2SD2144S(VW)	SILICON ROHM	
Q801	2SD2037(E,F)	SILICON ROHM	
Q802	2SB1357(E,F)	SILICON ROHM	
Q803	2SD2144S(VW)	SILICON ROHM	
Q804	2SD2144S(VW)	SILICON ROHM	
Q805	2SD2144S(VW)	SILICON ROHM	
Q806	2SA933S(R,S)	SILICON ROHM	
Q807	2SC1740S(R,S)	SILICON ROHM	
Q841	2SD2144S(VW)	SILICON ROHM	
Q861	2SA933S(R,S)	SILICON ROHM	
Q862	2SC1740S(R,S)	SILICON ROHM	
Q863	2SC1740S(R,S)	SILICON ROHM	
Q871	2SD2144S(VW)	SILICON ROHM	
Q872	2SD2144S(VW)	SILICON ROHM	
Q876	DTA114YS	SILICON ROHM	
Q991	DTA114YS	SILICON ROHM	
Q992	DTC114YS	SILICON ROHM	
Q993	DTC114YS	SILICON ROHM	

▲ SAFETY PARTS

I.C.s

ITEM	PART NUMBER	DESCRIPTION	AREA
IC761	STA341M(A)	I.C. SANKEN	
IC762	VC4580L	I.C. DAINICHI	
IC781	VC4580L	I.C. DAINICHI	
IC801	TL072S	I.C. DAINICHI	
IC802	BA10339	I.C. ROHM	
IC803	VC4580L	I.C. DAINICHI	
IC841	YM3805-H	I.C. YAHARA	
IC842	LC3517BS-15	I.C. SANYO	
IC843	M5209P	I.C. HITSUBISHI	
IC871	XRA15218N	I.C. EXAR JAPAN	
IC872	XRA15218N	I.C. EXAR JAPAN	
IC873	LC7881-C	I.C. SANYO	
IC991	HD404019R814S	I.C. HITACHI	
IC992	MN1281(P,R)	I.C. MATSUSHITA	

▲ SAFETY PARTS

Diodes

ITEM	PART NUMBER	DESCRIPTION	AREA
D703	MTZ5.6JC	ZENER ROHM	
D791	1SS133	SILICON ROHM	
D801	1SS133	SILICON ROHM	
D841	MTZ5.1JB	ZENER ROHM	
D842	SVC321-AW	VARICAP SANYO	
D871	1SS133	SILICON ROHM	
D872	1SS133	SILICON ROHM	
D873	MTZ5.1JB	ZENER ROHM	
D991	1SS133	SILICON ROHM	
D992	1SS133	SILICON ROHM	
D993	SLH-34VC3F	L.E.D. ROHM	

▲ SAFETY PARTS

Capacitors

ITEM	PART NUMBER	DESCRIPTION	AREA
C701	QETB1CM-227	220MF 16V ELECTRO	
C702	QETB1CM-227	220MF 16V ELECTRO	
C703	QETB1CM-227	220MF 16V ELECTRO	
C704	QETB1CM-227	220MF 16V ELECTRO	
C705	QETB1CM-476	47MF 16V ELECTRO	
C706	QCHB1EZ-223	0.022MF 25V CERAMIC	
C707	QETB1AM-227	220MF 10V ELECTRO	
C708	QCF21HP-223	0.022MF 50V CERAMIC	
C709	QCF21HP-223	0.022MF 50V CERAMIC	
C711	QFLB1HJ-472	4700PF 50V MYLAR	
C712	QFLB1HJ-472	4700PF 50V MYLAR	
C713	QCHB1EZ-223	0.022MF 25V CERAMIC	
C714	QCSB1HK-3R9	3.9PF 50V CERAMIC	
C715	QCB1HK-471	470PF 50V CERAMIC	
C716	QETB1EM-106	10MF 25V ELECTRO	
C717	QETB1CM-476	47MF 16V ELECTRO	
C718	QCSB1HJ-680	68PF 50V CERAMIC	
C719	QFV81HJ-154	0.15MF 50V T.FILM	
C721	QCSB1HJ-470	47PF 50V CERAMIC	
C722	QFV81HJ-103	0.01MF 50V T.FILM	
C723	QETB1EM-106	10MF 25V ELECTRO	
C724	QFV81HJ-473	0.047MF 50V T.FILM	
C725	QFV81HJ-474	0.47MF 50V T.FILM	
C726	QCSB1HJ-180	18PF 50V CERAMIC	
C731	QFV81HJ-183	0.018MF 50V T.FILM	
C732	QCB1HK-271	270PF 50V CERAMIC	
C733	QFV81HJ-393	0.039MF 50V T.FILM	
C734	QETB1CM-226	22MF 16V ELECTRO	
C735	QFV81HJ-104	0.1MF 50V T.FILM	
C736	QFV81HJ-224	0.22MF 50V T.FILM	
C761	QEN51HM-225	2.2MF 50V NON POLE	
C762	QETB1EM-226	22MF 25V ELECTRO	
C763	QETB0JM-227	220MF 6.3V ELECTRO	
C764	QCHB1EZ-223	0.022MF 25V CERAMIC	
C765	QCHB1EZ-223	0.022MF 25V CERAMIC	
C781	QFLB1HJ-272	2700PF 50V MYLAR	
C782	QCB1HK-101	100PF 50V CERAMIC	
C783	QEN51HM-225	2.2MF 50V NON POLE	
C784	QCHB1EZ-223	0.022MF 25V CERAMIC	
C785	QCHB1EZ-223	0.022MF 25V CERAMIC	
C791	QETB1HM-475	4.7MF 50V ELECTRO	
C801	QCT26CH-151	150PF 50V CERAMIC	
C802	QCT26CH-121	120PF 50V CERAMIC	
C803	QFV81HJ-223	0.022MF 50V T.FILM	
C805	QCSB1HK-4R7	4.7PF 50V CERAMIC	
C806	QEN51HM-225	2.2MF 50V NON POLE	
C807	QFV81HJ-563	0.056MF 50V T.FILM	
C808	QETB1CM-476	47MF 16V ELECTRO	
C809	QCHB1EZ-223	0.022MF 25V CERAMIC	
C810	QCHB1EZ-223	0.022MF 25V CERAMIC	
C811	QCHB1EZ-223	0.022MF 25V CERAMIC	
C812	QCHB1EZ-223	0.022MF 25V CERAMIC	
C813	QCHB1EZ-223	0.022MF 25V CERAMIC	
C815	QCHB1EZ-223	0.022MF 25V CERAMIC	
C816	QCHB1EZ-223	0.022MF 25V CERAMIC	
C841	QFV81HJ-103	0.01MF 50V T.FILM	
C842	QFV81HJ-474	0.47MF 50V T.FILM	
C843	QCSB1HK-102	1000PF 50V CERAMIC	
C844	QCHB1EZ-223	0.022MF 25V CERAMIC	
C845	QCHB1EZ-223	0.022MF 25V CERAMIC	
C846	QCSB1HJ-100	10PF 50V CERAMIC	
C847	QCSB1HJ-100	10PF 50V CERAMIC	
C848	QCHB1EZ-223	0.022MF 25V CERAMIC	
C849	QFP81HJ-151	150PF 50V POLY	
C850	QFP81HJ-471	470PF 50V POLY	
C851	QCHB1EZ-223	0.022MF 25V CERAMIC	
C852	QCHB1EZ-223	0.022MF 25V CERAMIC	
C853	QCHB1EZ-223	0.022MF 25V CERAMIC	
C854	QETB1HM-474	0.47MF 50V ELECTRO	
C857	QFV81HJ-124	0.12MF 50V T.FILM	
C858	QCHB1EZ-223	0.022MF 25V CERAMIC	
C859	QETB1AM-107	100MF 10V ELECTRO	
C861	QCB1HK-101	100PF 50V CERAMIC	
C862	QETB1CM-107	100MF 16V ELECTRO	
C863	QFV81HJ-473	0.047MF 50V T.FILM	
C864	QETB1EM-106	10MF 25V ELECTRO	
C865	QETB1HM-105	1MF 50V ELECTRO	
C871	QFLB1HJ-392	3900PF 50V MYLAR	
C872	QFLB1HJ-392	3900PF 50V MYLAR	
C873	QFV81HJ-683	0.068MF 50V T.FILM	
C874	QFV81HJ-683	0.068MF 50V T.FILM	
C875	QFV81HJ-103	0.01MF 50V T.FILM	
C876	QFV81HJ-103	0.01MF 50V T.FILM	
C877	QFLB1HJ-222	2200PF 50V MYLAR	
C878	QFLB1HJ-222	2200PF 50V MYLAR	
C879	EEZ2505-476	47MF ELECTRO	
C880	EEZ2505-476	47MF ELECTRO	
C881	QFLB1HJ-562	5600PF 50V MYLAR	
C882	QFLB1HJ-562	5600PF 50V MYLAR	
C883	QCHB1EZ-223	0.022MF 25V CERAMIC	
C884	QCHB1EZ-223	0.022MF 25V CERAMIC	
C885	QCHB1EZ-223	0.022MF 25V CERAMIC	
C886	QCHB1EZ-223	0.022MF 25V CERAMIC	
C887	QFLC1HJ-102Z	1000PF 50V MYLAR	
C888	QETB1CM-107	100MF 16V ELECTRO	

▲ SAFETY PARTS

Capacitors

Δ	ITEM	PART NUMBER	DESCRIPTION	AREA
	C889	QETB1CM-107	100MF 16V ELECTRO	
	C890	QETB1AM-107	100MF 10V ELECTRO	
	C891	QCF21HP-223	0.022MF 50V CERAMIC	
	C893	EEZ2503-107	100MF ELECTRO	
	C894	QCHB1EZ-223	0.022MF 25V CERAMIC	
	C895	QFV81HJ-124	0.12MF 50V T. FILM	
	C896	QETB1AM-107	100MF 10V ELECTRO	
	C897	QETB1CM-107	100MF 16V ELECTRO	
	C898	QETB1CM-107	100MF 16V ELECTRO	
	C992	QETB1HM-475	4.7MF 50V ELECTRO	
	C993	QER61HM-475	4.7MF 50V ELECTRO	
	C994	QEK51HM-226	22MF 50V ELECTRO	
	C995	QERSOJM-107	100MF 6.3V ELECTRO	
	C996	QETB1AM-227	220MF 10V ELECTRO	
	C997	QCHB1EZ-223	0.022MF 25V CERAMIC	

Δ : : : SIA:FEITYI : P:ART'S

Resistors

Δ	ITEM	PART NUMBER	DESCRIPTION	AREA
	R701	PTH6IG25AR4R7	THERMISTOR	
	R702	PTH6IG25AR4R7	THERMISTOR	
Δ	R703	QRZ0077-100	10 1/4W FUSIBLE	
Δ	R704	QRZ0077-100	10 1/4W FUSIBLE	
	R705	QRD167J-472	4.7K 1/6W CARBON	
	R706	QRD167J-472	4.7K 1/6W CARBON	
	R708	QRD167J-222	2.2K 1/6W CARBON	
	R709	QRD167J-122	1.2K 1/6W CARBON	
	R710	QRD167J-121	120 1/6W CARBON	
	R711	QRD167J-183	18K 1/6W CARBON	
	R712	QRD167J-432	4.3K 1/6W CARBON	
	R713	QRD167J-391	390 1/6W CARBON	
	R714	QRD167J-221	220 1/6W CARBON	
	R715	QRD167J-152	1.5K 1/6W CARBON	
	R716	QRD167J-561	560 1/6W CARBON	
	R717	QRD167J-561	560 1/6W CARBON	
	R718	QRD167J-562	5.6K 1/6W CARBON	
	R719	QRD167J-152	1.5K 1/6W CARBON	
	R720	QRD167J-271	270 1/6W CARBON	
	R721	QRD167J-471	470 1/6W CARBON	
	R722	QRD167J-472	4.7K 1/6W CARBON	
	R723	QRD167J-154	150K 1/6W CARBON	
	R724	QRD167J-562	5.6K 1/6W CARBON	
	R725	QRD167J-103	10K 1/6W CARBON	
	R726	QRD167J-104	100K 1/6W CARBON	
	R727	QRD167J-183	18K 1/6W CARBON	
	R728	QRD167J-562	5.6K 1/6W CARBON	
	R731	QRD167J-104	100K 1/6W CARBON	
	R732	QRD167J-104	100K 1/6W CARBON	
	R733	QRD167J-394	390K 1/6W CARBON	
	R734	QRD167J-394	390K 1/6W CARBON	
	R735	QRD167J-121	120 1/6W CARBON	
	R736	QRD167J-182	1.8K 1/6W CARBON	
	R737	QRD167J-681	680 1/6W CARBON	
	R738	QRD167J-473	4.7K 1/6W CARBON	
	R739	QRD167J-331	330 1/6W CARBON	
	R740	QRD167J-333	33K 1/6W CARBON	
	R741	QRD167J-273	27K 1/6W CARBON	
	R742	QRD167J-394	390K 1/6W CARBON	
	R743	QRD167J-105	1M 1/6W CARBON	
	R744	QRD167J-470	47 1/6W CARBON	
	R745	QRD167J-473	4.7K 1/6W CARBON	
	R746	QRD167J-272	2.7K 1/6W CARBON	
	R747	QRD167J-682	6.8K 1/6W CARBON	
	R748	QRD167J-104	100K 1/6W CARBON	
	R749	QRD167J-562	5.6K 1/6W CARBON	
	R750	QRD167J-105	1M 1/6W CARBON	
	R751	QRD167J-105	1M 1/6W CARBON	
	R752	QRD167J-104	100K 1/6W CARBON	
	R753	QRD167J-562	5.6K 1/6W CARBON	
	R754	QRD167J-104	100K 1/6W CARBON	
	R755	QRD167J-103	10K 1/6W CARBON	
	R756	QRD167J-470	47 1/6W CARBON	
	R757	QRD167J-183	18K 1/6W CARBON	
	R758	QRD167J-183	18K 1/6W CARBON	
	R759	QRD167J-681	680 1/6W CARBON	
	R760	QRD167J-681	680 1/6W CARBON	
	R761	QRD167J-564	560K 1/6W CARBON	
	R762	QRD167J-224	220K 1/6W CARBON	
	R763	QRD167J-393	39K 1/6W CARBON	
	R764	QRD167J-224	220K 1/6W CARBON	
	R765	QRD167J-562	5.6K 1/6W CARBON	
	R766	QRD167J-392	3.9K 1/6W CARBON	
	R767	QRD167J-681	680 1/6W CARBON	
	R768	QRD167J-103	10K 1/6W CARBON	
	R769	QRD167J-102	1K 1/6W CARBON	
	R770	QRD167J-471	470 1/6W CARBON	
	R771	QRD167J-683	68K 1/6W CARBON	
	R772	QRD167J-183	18K 1/6W CARBON	
	R773	QRD167J-273	27K 1/6W CARBON	
	R774	QRD167J-470	47 1/6W CARBON	
	R775	QRD167J-335	3.3M 1/6W CARBON	
	R776	QRD167J-681	680 1/6W CARBON	
	R781	QRD167J-684	680K 1/6W CARBON	
	R782	QRD167J-684	680K 1/6W CARBON	

Δ : : : SIA:FEITYI : P:ART'S

Resistors

Δ	ITEM	PART NUMBER	DESCRIPTION	AREA
	R783	QRD167J-823	82K 1/6W CARBON	
	R784	QRD167J-470	47 1/6W CARBON	
	R785	QRD167J-683	68K 1/6W CARBON	
	R786	QRD167J-123	12K 1/6W CARBON	
	R787	QRD167J-152	1.5K 1/6W CARBON	
	R788	QRD167J-2R2	2.2 1/6W CARBON	
	R790	QRD167J-684	680K 1/6W CARBON	
	R791	QRD167J-513	51K 1/6W CARBON	
	R792	QRD167J-513	51K 1/6W CARBON	
	R793	QRD167J-683	68K 1/6W CARBON	
	R794	QRD167J-683	68K 1/6W CARBON	
	R795	QRD167J-221	220 1/6W CARBON	
	R797	QRZ0077-4R7	4.7 1/4W FUSIBLE	
	R801	QRD167J-563	56K 1/6W CARBON	
	R802	QRD167J-563	56K 1/6W CARBON	
	R803	QRD167J-222	2.2K 1/6W CARBON	
	R804	QRD167J-681	680 1/6W CARBON	
	R805	QVPA601-202A	2K VARIABLE	
	R806	QRD167J-561	560 1/6W CARBON	
	R807	QRD167J-334	330K 1/6W CARBON	
	R808	QRD167J-222	2.2K 1/6W CARBON	
	R809	QVPA601-154A	150K VARIABLE	
	R810	QRD167J-223	22K 1/6W CARBON	
	R811	QRD167J-682	6.8K 1/6W CARBON	
	R812	QRD167J-103	10K 1/6W CARBON	
	R813	QRD167J-562	5.6K 1/6W CARBON	
	R814	QRD167J-562	5.6K 1/6W CARBON	
	R815	QRD167J-562	5.6K 1/6W CARBON	
	R816	QRD167J-562	5.6K 1/6W CARBON	
	R817	QRD167J-183	18K 1/6W CARBON	
	R819	QRD167J-103	10K 1/6W CARBON	
	R820	QRD167J-224	220K 1/6W CARBON	
	R821	QRD167J-103	10K 1/6W CARBON	
	R822	QRD167J-183	18K 1/6W CARBON	
	R823	QRD167J-434	430K 1/6W CARBON	
	R824	QRD167J-434	430K 1/6W CARBON	
	R825	QRD167J-103	10K 1/6W CARBON	
	R827	QRD167J-104	100K 1/6W CARBON	
	R828	QRD167J-104	100K 1/6W CARBON	
	R829	QRD167J-681	680 1/6W CARBON	
	R830	QRD167J-183	18K 1/6W CARBON	
	R831	QRD167J-104	100K 1/6W CARBON	
	R832	QRD167J-102	1K 1/6W CARBON	
	R833	QRD167J-562	5.6K 1/6W CARBON	
	R834	QRD167J-183	18K 1/6W CARBON	
	R835	QRD167J-183	18K 1/6W CARBON	
	R836	QRD167J-394	390K 1/6W CARBON	
	R837	QRD167J-470	47 1/6W CARBON	
	R838	QRD167J-562	5.6K 1/6W CARBON	
	R839	QRD167J-183	18K 1/6W CARBON	
	R841	QRD167J-682	6.8K 1/6W CARBON	
	R842	QRD167J-181	180 1/6W CARBON	
	R843	QRD167J-331	330 1/6W CARBON	
	R844	QRD167J-272	2.7K 1/6W CARBON	
	R845	QRD167J-471	470 1/6W CARBON	
	R846	QRD167J-681	680 1/6W CARBON	
Δ	R847	QRV144F-1602	16K 1/4W M. FILM	
Δ	R848	QRV144F-1502	15K 1/4W M. FILM	
	R849	QRD167J-183	18K 1/6W CARBON	
	R851	QRD167J-183	18K 1/6W CARBON	
	R852	QRD167J-102	1K 1/6W CARBON	
	R853	QRD167J-152	1.5K 1/6W CARBON	
	R854	QRD167J-104	100K 1/6W CARBON	
	R855	QRD167J-821	820 1/6W CARBON	
	R857	QRD167J-471	470 1/6W CARBON	
	R858	QRD167J-682	6.8K 1/6W CARBON	
	R859	QRD167J-105	1M 1/6W CARBON	
	R861	QRD167J-103	10K 1/6W CARBON	
	R862	QRD167J-272	2.7K 1/6W CARBON	
	R863	QRD167J-102	1K 1/6W CARBON	
	R864	QRD167J-271	270 1/6W CARBON	
	R865	QRD167J-103	10K 1/6W CARBON	
	R866	QRD167J-562	5.6K 1/6W CARBON	
	R867	QRD167J-472	4.7K 1/6W CARBON	
	R868	QRD167J-822	8.2K 1/6W CARBON	
	R869	QRD167J-103	10K 1/6W CARBON	
	R870	QRD167J-101	100 1/6W CARBON	
	R871	QRD167J-472	4.7K 1/6W CARBON	
	R872	QRD167J-472	4.7K 1/6W CARBON	
	R873	QRD167J-751	750 1/6W CARBON	
	R874	QRD167J-751	750 1/6W CARBON	
	R875	QRD167J-471	470 1/6W CARBON	
	R876	QRD167J-471	470 1/6W CARBON	
	R877	QRD167J-221	220 1/6W CARBON	
	R878	QRD167J-221	220 1/6W CARBON	
	R879	QRD167J-105	1M 1/6W CARBON	
	R880	QRD167J-105	1M 1/6W CARBON	
	R881	QRD167J-392	3.9K 1/6W CARBON	
	R882	QRD167J-392	3.9K 1/6W CARBON	
	R883	QRD167J-821	820 1/6W CARBON	
	R884	QRD167J-821	820 1/6W CARBON	
	R885	QRD167J-821	820 1/6W CARBON	
	R886	QRD167J-821	820 1/6W CARBON	
	R887	QRD167J-272	2.7K 1/6W CARBON	
	R888	QRD167J-272	2.7K 1/6W CARBON	

Δ : : : SIA:FEITYI : P:ART'S

Resistors

Δ	ITEM	PART NUMBER	DESCRIPTION	AREA
	R889	QRD167J-273	27K 1/6W CARBON	
	R890	QRD167J-273	27K 1/6W CARBON	
	R891	QRD167J-561	560 1/6W CARBON	
	R892	QRD167J-561	560 1/6W CARBON	
	R893	QRD167J-104	100K 1/6W CARBON	
	R894	QRD167J-105	1M 1/6W CARBON	
	R895	QRD167J-681	680 1/6W CARBON	
	R899	QRD167J-152	1.5K 1/6W CARBON	
	R990	QRD167J-3R3	3.3 1/6W CARBON	
	R991	QRD167J-471	470 1/6W CARBON	
	R992	QRD167J-473	47K 1/6W CARBON	
	R993	QRD167J-3R3	3.3 1/6W CARBON	
	R994	QRD167J-103	10K 1/6W CARBON	
	R995	QRD167J-472	4.7K 1/6W CARBON	
	R996	QRD167J-105	1M 1/6W CARBON	
	R997	QRD167J-473	47K 1/6W CARBON	
	R998	QRD167J-331	330 1/6W CARBON	
	R999	QRD167J-472	4.7K 1/6W CARBON	
	RA801	QRB045J-472	4.7K 1/8W R.NETWORK	
	RA991	QRB045J-473	47K 1/8W R.NETWORK	

Δ IS SAFETY PARTS

Others

Δ	ITEM	PART NUMBER	DESCRIPTION	AREA
		EMW10002-201	CIRCUIT BOARD	
		E306951-002	FL DISPLAY HOLDER	
		E3400-420	FELT SPACER	
		E70859-001	EARTH PLATE	
	J441	EMV7130-013	CONNECTOR (13PIN)	
	L841	ENZ3001-002	OSCILLATOR COIL	
	P991	EMV7123-024	CONNECTOR (24PIN)	
	P992	EMV7123-024R	CONNECTOR (24PIN)	
	P993	EMV7123-013	CONNECTOR (13PIN)	
	P994	EMV5109-010A	PLUG ASSY (10PIN)	
	S981	ESP0001-018	TACT SWITCH (STOP/CLEAR)	
	S982	ESP0001-018	TACT SWITCH (D H) AUTO SEARCH	
	S983	ESP0001-018	TACT SWITCH (PLAY/PAUSE)	
	S984	ESP0001-018	TACT SWITCH (OPEN/CLOSE)	
	S985	ESP0001-018	TACT SWITCH (DISPLAY)	
	S986	ESP0001-018	TACT SWITCH (A.EDIT)	
	S987	ESP0001-018	TACT SWITCH (H Q) AUTO SEARCH	
	S988	ESP0001-018	TACT SWITCH (FADE)	
	S989	ESP0001-018	TACT SWITCH (REPEAT)	
	S990	ESP0001-018	TACT SWITCH (PROGRAM)	
	S991	ESP0001-018	TACT SWITCH (RANDOM)	
	S992	ESP0001-018	TACT SWITCH (AUTO POWER)	
	X841	ECX0086-436WT	RESONATOR	
	CF991	ECX0004-194KM	RESONATOR	
	FL991	ELU0001-114	FL TUBE	
	FW991	EWR36B-10LST	FLAT WIRE (6PIN)	
	FW992	EWR38B-10LST	FLAT WIRE (8PIN)	
	FW993	EWR37B-10LST	FLAT WIRE (7PIN)	
	FW994	EWR35B-40SST	FLAT WIRE (8PIN)	
	FW995	EWR33B-45SST	FLAT WIRE (3PIN)	
	JB441	EMP902-020	PLUG WIRE ASSY (13PIN)	
	J1991	EMV7122-103	CONNECTOR (3PIN)	
	J1992	EMV7122-103	CONNECTOR (3PIN)	
	J1993	EMV7122-004	CONNECTOR (4PIN)	
	J1994	EMV7122-004	CONNECTOR (4PIN)	
	J1995	EMV7122-103	CONNECTOR (3PIN)	
	J1996	EMV7122-004	CONNECTOR (4PIN)	
	J1997	EMV7122-103	CONNECTOR (3PIN)	

Δ IS SAFETY PARTS

JVC

SERVICE MANUAL

COMPACT COMPONENT SYSTEM

MODEL No. **DX-MX70BK**

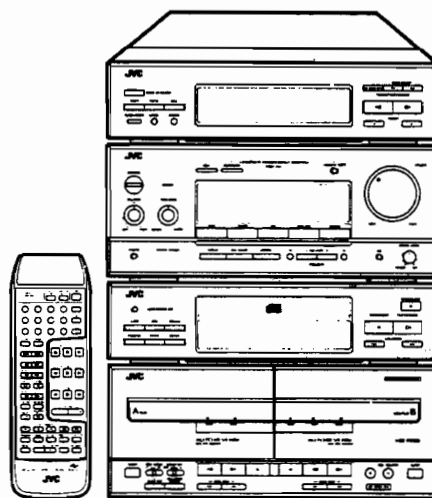

COMPACT
disc
DIGITAL AUDIO

This Service Manual is mainly for Accessories List, Packing Materials, Part Numbers and Instruction Book. About the disassembly procedure, adjustment procedure and so on, we issued another four Service Manuals for AX-MX70BK, FX-MX70BK, TD-MX70BK, and XL-MX70BK, so please refer to them.

Component

Compact component (DX-MX70BK) is a unit composing of the following units.

Model No.	Unit No.	Service Manual No.
DX-MX70BK	AX-MX70BK(Amplifier)	20244
	FX-MX70BK(Tuner)	20245
	TD-MX70BK(Cassette Deck)	20246
	XL-MX70BK(CD Player)	20247

■ Packing Materials and Part Numbers

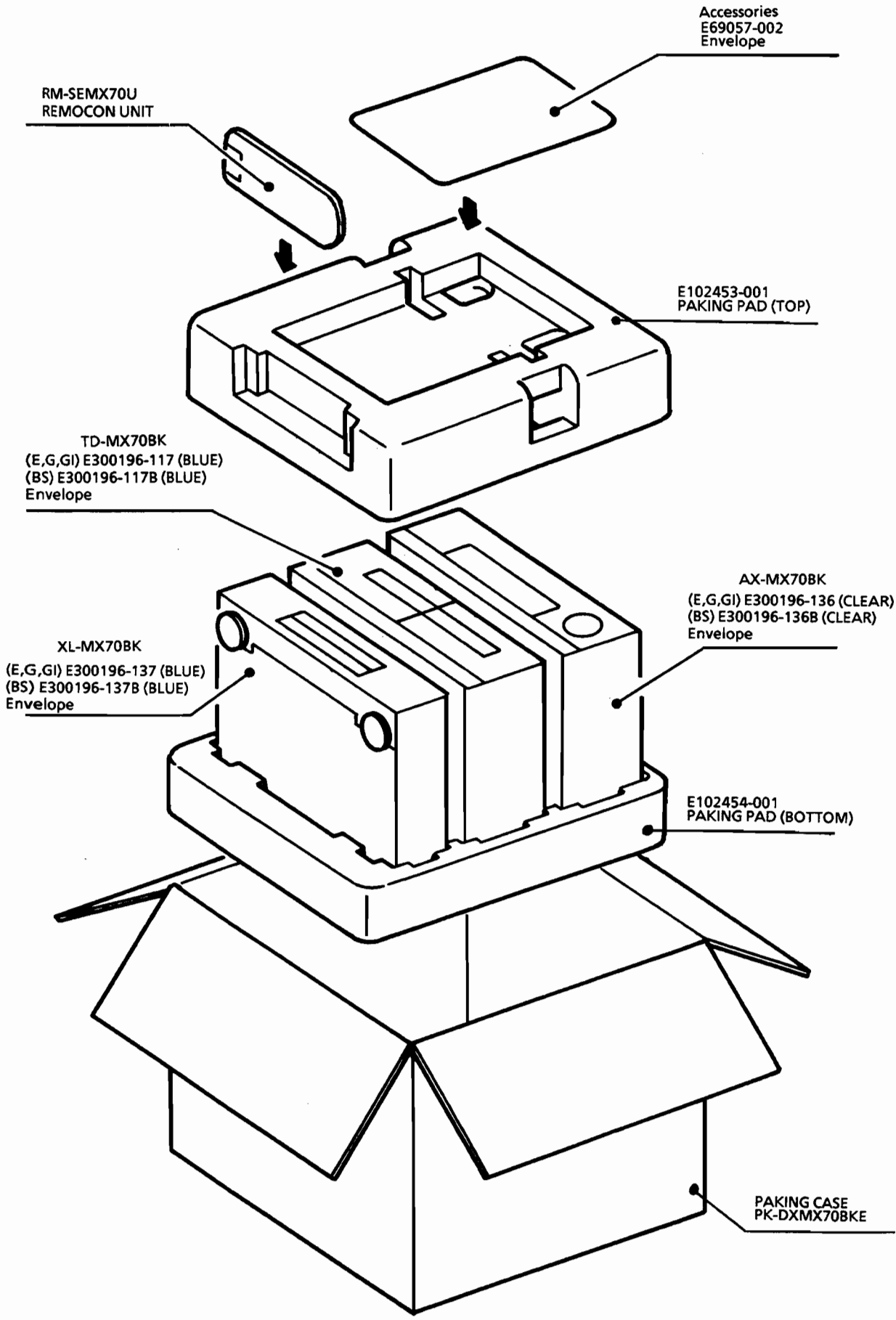

■ Accessories List

⚠	Part Number	Part Name	Q'ty	Description	Areas
	E30580-1744A	Instruction Book	1		BS,E,G
	E30580-1745A	Instruction Book	1		GI
	BT-20117	Warranty Card	1		G
	BT20060	Warranty Card	1		BS
	BT20066A	EEC Agency	1		BS
	E43486-340A	Safety Sheet	1		BS
	E43486-451	Caution Sheet	1		BS,E,G,GI
	QZL1008-001	FTZ Information Sheet	1		G
	QPGA025-03505B	Envelope	1	for Instruction Book	BS
	QPGA025-03505	Envelope	1	for Instruction Book	E,G,GI
	EQB4001-015	AM Loop Antenna	1		BS,E,G,GI
	E67007-001	Wire Antenna	1		G
	EWP101-006	Speaker Cord Ass'y	2		BS,E,G,GI
	EWP502-005K	Built in Antenna	1		BS,E,G,GI
	EMZ2001-011	Adapter	1		BS,E,GI
	E35960-012	Assuring Card	1		BS,E,G,GI
	UM-4NJ-2PSA	Battery	2		BS,E,G,GI
	E304880-001	Cord Holder	1		BS,E,G,GI

The Marks for Designated Areas

BS ... the U.K.	E ... Continental Europe
G ... Germany	GI ... Italy

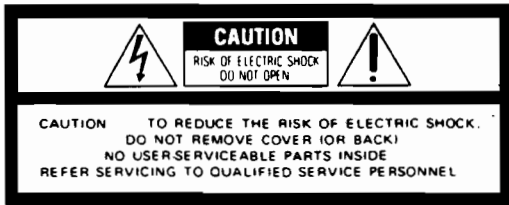

WARNING: TO REDUCE THE RISK OF FIRE OR ELECTRIC SHOCK, DO NOT EXPOSE THIS APPLIANCE TO RAIN OR MOISTURE.



The lightning flash with arrowhead symbol, within an equilateral triangle, is intended to alert the user to the presence of uninsulated "dangerous voltage" within the product's enclosure that may be of sufficient magnitude to constitute a risk of electric shock to persons.



The exclamation point within an equilateral triangle is intended to alert the user to the presence of important operating and maintenance (servicing) instructions in the literature accompanying the appliance.

IMPORTANT FOR LASER PRODUCTS

1. CLASS 1 LASER PRODUCT
2. **DANGER:** Invisible laser radiation when open and interlock failed or defeated. Avoid direct exposure to beam.
3. **CAUTION:** Do not open the top cover. There are no user serviceable parts inside the unit; leave all servicing to qualified service personnel.

Table of Contents

Introduction			
<i>Features</i>	3		
<i>About This Manual</i>	3		
<i>Care and Handling</i>	4		
<i>Important Notes</i>	4		
Getting Started			
<i>Connecting the System Components</i>	6		
<i>AM and FM Antenna Connections</i>	7		
<i>Connecting Other Components</i>	8		
<i>Installing Batteries in the Remote Controller</i>	8		
<i>AC Power Connection</i>	8		
Using the Amplifier			
<i>Using the Power Switch</i>	9		
<i>Adjusting the Volume Controls</i>	9		
<i>Using the SEA Function</i>	9		
<i>Changing the SEA Display</i>	9		
<i>Using Turntable, VCR, and DAT</i>	10		
<i>Playing Back with a Surround Sound Effect</i>	10		
<i>Mixing the Microphone Sound</i>	10		
<i>Using the LEARNING CSRP Feature</i>	10		
<i>Using the Loudness Function</i>	10		
Using the CD Player			
<i>Starting Playback</i>	11		
<i>Selecting a Track to Play</i>	11		
<i>Using the Remote Controller to Select a Track</i>	11		
<i>Listening Repeatedly</i>	11		
<i>Displaying the Elapsed and Remaining Playing Time</i>	12		
<i>Programming Your Own Playback Sequence</i>	12		
<i>Playing Tracks at Random</i>	13		
<i>Using the AUTO POWER OFF Function</i>	13		
Using the Tape Deck			
<i>Playing a Tape</i>	14		
<i>Listening to Tape Continuously</i>	14		
<i>Skipping Blanks</i>	14		
<i>Music Scanning</i>	15		
<i>Recording a Tape</i>	15		
<i>Dubbing a Tape</i>	15		
<i>Erasing a Tape</i>	16		
<i>Direct Recording from the CD Player</i>	16		
<i>Recording CD Tracks in Auto-Edit Mode</i>	17		
<i>Recording CD Tracks in Programmed-Edit Mode</i>	17		
<i>Recording with the SEA Function</i>	18		
<i>Creating a Blank During Recording</i>	18		
<i>Recording with the Timer</i>	18		
Using the Tuner			
<i>Listening to Broadcasts</i>	19		
<i>Presetting Stations in Memory</i>	19		
Using the Timers			
<i>Setting the Clock</i>	20		
<i>Setting the Timers</i>	20		
<i>Setting the Wake-Up and Sleep Timers</i>	21		
Using the Remote Controller			
<i>Operating the Remote Controller</i>	23		
Troubleshooting	25		
Specifications	26		

Introduction

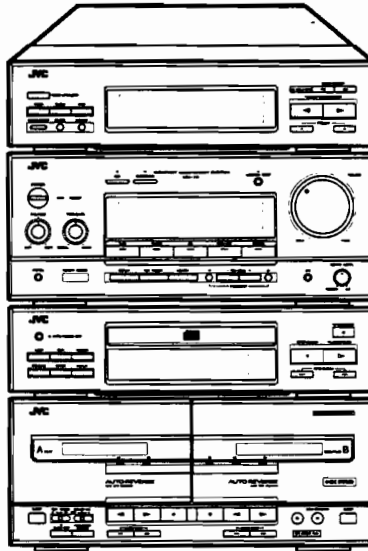

This system produces a full, powerful bass sound.

- With JVC's newly-developed forced air cooling system, Compact component system can produce the same high-quality bass sound as a large stereo system.

Thank you for purchasing this JVC Compact Component Stereo System. We hope it will be valued addition to your home, giving you years of enjoyment.

Be sure to read this instruction manual carefully before operating your new stereo system. Here you will find all the information you need to set up and use the system.

For questions that cannot be answered in this manual, please contact your dealer.

Features

It has a variety of functions, which are equivalent to those of large, expensive stereo systems.

- Remote control of computerized 7-band SEA graphic equalizer.
- Programmable timers for setting recording, wake-up music, and fall-asleep music.
- Storage of 40 radio stations (FM and AM) in memory.
- Fade-out of last track during direct CD-to-tape recording.
- CD tracks can be recorded on both sides of a cassette tape without splitting songs at the end of a side.
- CD tracks can be played back or recorded on both sides of a cassette tape in any order.
- Input terminals for connecting a turntable, a Digital Audio Tape (DAT) Deck, and the sound portion of Video Cassette Recorder (VCR).

About This Manual

This instruction manual will help you with the following:

- Connecting the components of the system, installing the antennas, and connecting other components such as a turntable or VCR to the system.
- Learning the operations of the components of the system (Amplifier, CD Player, Tape Deck, Tuner, and the Remote Controller).
- Learning additional functions of the system, such as using the timers, using the SEA graphic equalizer, presetting broadcast stations in memory, and using the various recording capabilities.
- Trouble-shooting, if a problem should occur.

Laying Out the System

There are two ways to lay out the system as shown below.

- Leave a space of at least one cm on both sides of the amplifier and keep the back at least 10 cm from the wall for ventilation.

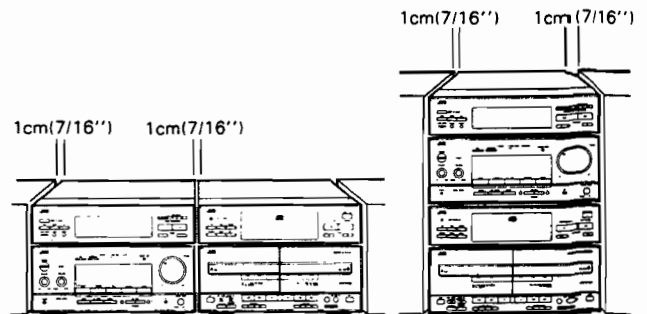

Care and Handling

You must handle your compact discs, cassette tapes, and tape deck carefully to keep them for a long time.

Cassette Tape



- If the tape is loose in the cassette, take up the slack by inserting a pencil in one of the reels and rotating. If the tape is loose, it may get stretched, cut, or caught in the cassette.



- Do not touch the tape surface.



- Do not store the tape:
 - In dusty places
 - In direct sunlight or heat
 - In moist areas
 - On a TV or speaker
 - Near a magnet

Tape Deck

- If the head, capstans, and pinch-rollers of the tape deck become dirty, the following will occur:
 - Impaired sound quality
 - Discontinuous sound
 - Fading
 - Incomplete erasure
 - Impossible to record
- Clean the head, capstans, and pinch-rollers with a cotton swab moistened with alcohol.

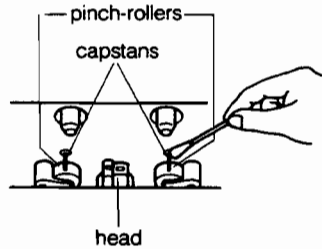

- If the head becomes magnetized, it will produce noise or lose high frequencies.

To demagnetize the head, turn off the system, and use a head demagnetizer (available at electronics and record shops).

Compact Discs



- Remove the CD from the case by holding it at the edges while pressing the center hole lightly.
- Do not touch the shiny surface of the CD, or bend the CD.

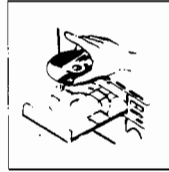

- Place the CD in the tray with the label up.

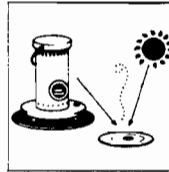

- Put the CD back in its case after use to prevent warping.
- Avoid exposure to direct sunlight, temperature extremes, and moisture.

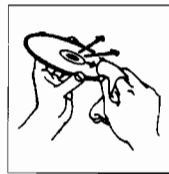

- If the CD becomes dirty, wipe it with a soft dry cloth in a straight line from center to edge.

Caution! Do not use any solvent (for example, conventional record cleaner, spray, thinner, benzine, etc.)

Only use compact-discs bearing the mark shown below.



Important Notes

- 1. Installation**
 - Select a place which is level, dry, and neither too hot nor too cold (between 5 and 35 degrees Celsius/41 and 95 degrees Fahrenheit).
 - Be sure there is adequate ventilation; poor ventilation may cause the unit to malfunction.
 - Leave sufficient distance between the receiver and your TV.
- 2. Power**
 - Do not handle the power cord with wet hands!
 - When unplugging from the wall outlet, always pull the plug, not the power cord.
- 3. Malfunctions, etc.**
 - Do not insert any metallic objects into the receiver.

Caution

To reduce the risk of electrical shocks, fire, etc.:

1. Do not remove screws, covers or cabinet.
2. Do not expose this appliance to rain or moisture.

Getting Started

Connecting the System Components

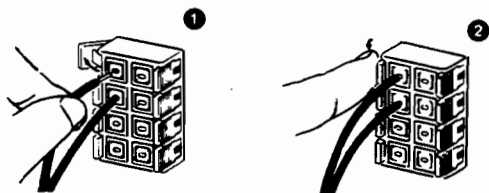
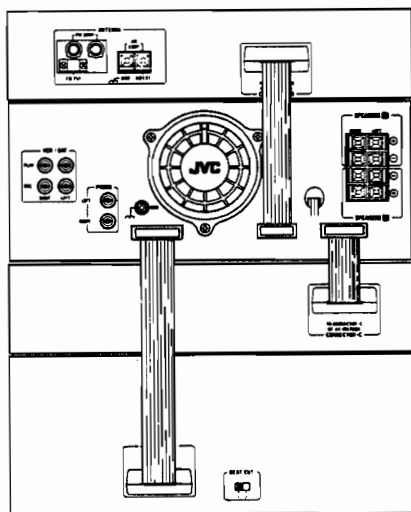

Example:

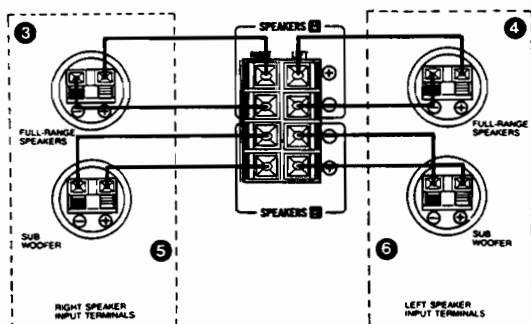

Connection Notes

- Before you plug in the system, you must make all the necessary connections.

Connecting the Four Stereo Components

- Connecting the Tuner, Amplifier, CD Player, and Tape Deck.
- Connect three ribbon cables extending from the tuner, CD player, and tape deck to the amplifier.
- If the system does not work well or needs repairing, please take all the components with you to the nearest agent.

Connecting the Speakers

Speaker Terminals

- 1 When connecting speakers, open each terminal and insert the end of the speaker wire as shown.
- 2 Close the terminals as shown to clamp the speaker wires in place.

SPEAKERS A

Connect the Full Range Speakers to the SPEAKERS A terminal on the amplifier as follows.

- 3 Connect the (+) and (-) terminals of the right-side Full Range Speaker to the upper (+) and (-) terminals marked RIGHT on the amplifier.
- 4 Connect the (+) and (-) terminals of the left-side Full Range Speaker to the upper (+) and (-) terminals marked LEFT on the amplifier.

SPEAKERS B

Connect the Subwoofers to the SPEAKER B terminal on the amplifier as follows.

- 5 Connect the (+) and (-) terminals of the right-side Subwoofer to the lower (+) and (-) terminals marked RIGHT on the amplifier.
- 6 Connect the (+) and (-) terminals of the left-side Subwoofer to the lower (+) and (-) terminals marked LEFT on the amplifier.

Note: Connect speaker cables to terminals matching cable colors with terminal lever color.

- Use speakers with the correct impedance. The correct impedance is indicated on the rear panel of the amplifier.

AM and FM Antenna Connections

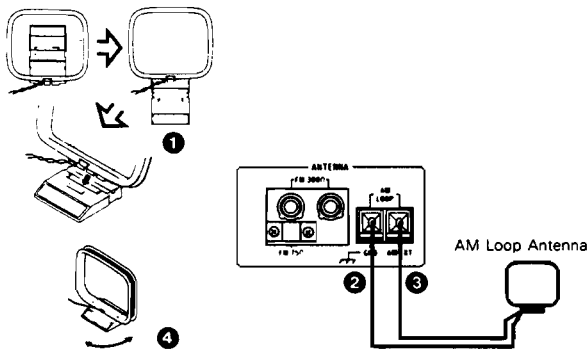

To receive radio broadcasts, you will have to connect AM and FM antennas to the Tuner.

An AM loop antenna is included with your system.

FM antennas use two types of cable connections: 75-ohm cables have a round coaxial connection while 300-ohm cables

AM Loop Antenna

- 1 Fold out the loop from the antenna base.
- 2 Connect one antenna wire to one of the AM LOOP terminals.
- 3 Connect the remaining antenna wire to the other AM LOOP terminal.
Note: These two terminals open and close the same way as the speaker terminals.
- 4 Adjust the loop antenna as needed to get the best reception.

AM Outdoor Antenna

If your AM broadcast reception is unsatisfactory, you should connect an AM outdoor antenna in addition to the loop antenna.

Important! The AM loop antenna must be installed to receive AM broadcasts. Do not disconnect the loop antenna when installing an outdoor antenna.

- 1 Install a single vinyl-covered antenna wire outdoors. The antenna wire should be about 16 to 40 feet (5 to 12 meters) long.
- 2 Connect one end of the antenna to the AM loop terminal marked AM EXT.
Note: Except for the connection, make sure no uninsulated antenna wire touches the rear panel of this system. Otherwise, you might not receive AM broadcasts.

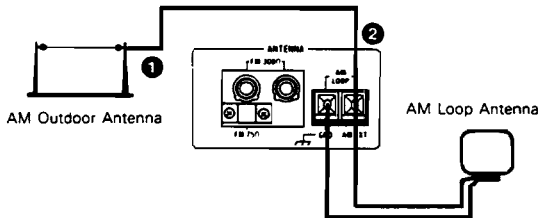

FM 75-Ohm Antenna Cable

- 1 Loosen the screws holding the bracket.
- 2 Loosen the cap of the 300/75-ohm terminal.
- 3 Insert the round antenna cable through the bracket from below.
- 4 Make sure that the shield braid on the cable contacts the bracket, and that the center conductor of the cable contacts the 300/75-ohm terminal.
- 5 Tighten the bracket screws and the cap on the 300/75-ohm terminal.

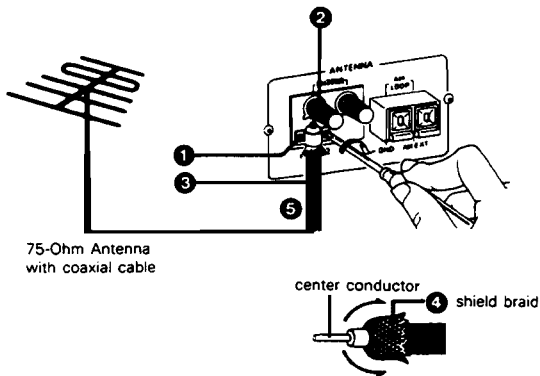

FM 300-Ohm Antenna Cable

- 1 Loosen the cap on the 300/75-ohm terminal.
- 2 Loosen the cap on the 300-ohm terminal.
- 3 Connect the two conductors of the antenna cable to the 300/75-ohm terminal and the 300-ohm terminal.
- 4 Tighten the caps on both terminals.

Note: Whether you use the 75-ohm or 300-ohm cable, make sure the antenna conductors do not touch any other terminals on the rear panel. This could cause poor reception.

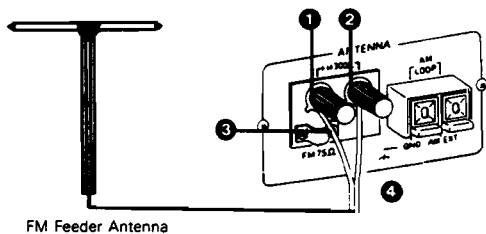

Connecting Other Components

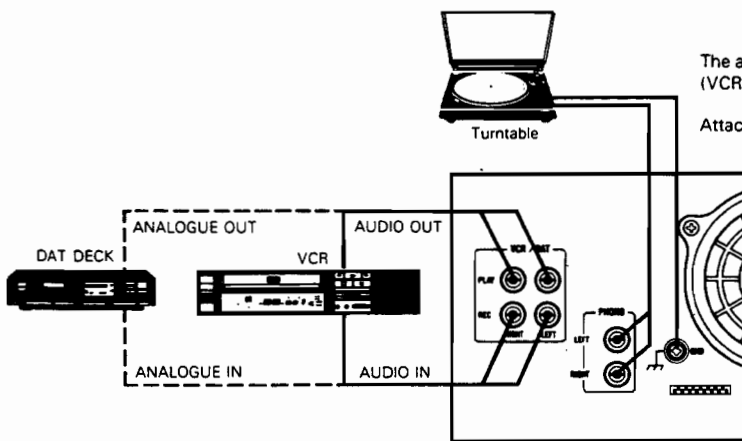

The amplifier can also be connected to a turntable, a Video Cassette Recorder (VCR), and a Digital Audio Tape (DAT) Deck.

Attach these components as shown.

Installing the Batteries in the Remote Controller

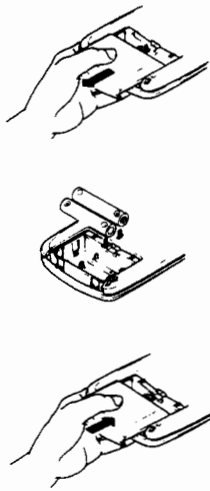

1. Remove the battery compartment lid.

Press the lid and slide it in the direction of the arrow.

2. Insert the batteries.

Use two UM-4/AAA/R03 size batteries. Make sure the + and - polarities on the batteries and compartment are the same.

3. Attach the lid.

Press the lid and slide it in the direction of the arrow.

Note: Batteries installed incorrectly may burst or leak. Pay attention to the following:

- When the Remote Controller is not in use for a long period of time, remove the batteries.
- Do not mix old and new batteries.
- Do not mix batteries of different types, even if their shapes are the same.
- When batteries become weak, the operating distance of the Remote Controller is greatly reduced and you will need to replace the batteries.

AC Power Connection

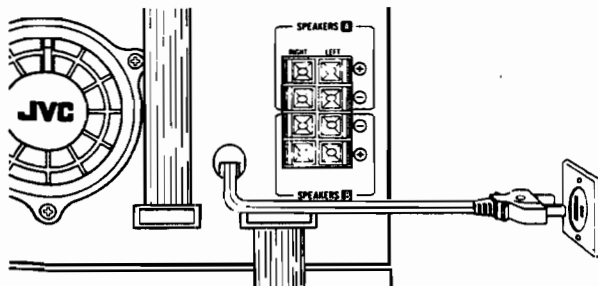

Plug the power cord on the back of the amplifier into a 120 Volt, 60 Hz AC household electrical outlet.

Caution: To prevent electric shock, turn all stereo components off before you install or remove power cords.

Important! Before you plug the power cord into an outlet, make sure all stereo components are connected correctly.

Using the Amplifier

Using the Power Switch

1. Press the **POWER** switch to turn on the stereo system.

When the POWER switch is not pressed and the power cord is plugged in, the stereo is in **STANDBY** mode and **STANDBY** indicator lights. In **STANDBY** mode, the stereo uses a small amount of power (13 watts) for the clock, memory contents, and any timers which are set.

2. To disconnect power completely, unplug the power cord.

Adjusting the Volume Controls

Volume

Turn the **VOLUME** knob to adjust the volume level of the speakers or headphones.

- Connect headphones to the **PHONES** jack on the amplifier for listening through headphones. No sound will be produced from the speakers.
- Turn the **MIXING LEVEL** knob to the **SOURCE** position unless a microphone is used.

Balance

Turn the **BALANCE** knob to adjust the left-and-right sound balance in the speakers or headphones.

Twin Bass

Turn the **TWIN BASS** knob to adjust the output level of the Subwoofers. Turning this control toward **MAX** will boost the low frequencies.

Using the SEA Function

You can think of the SEA function as an enhanced version of the conventional Bass and Treble knobs on most sound systems. Use it to alter the tone of the source (for example, CD, tape, or broadcast) by increasing or decreasing the levels of selected frequency ranges.

The total frequency range that the amplifier can reproduce (from the lowest-pitched sounds to the highest) is divided into seven sections: 63Hz, 160Hz, 400Hz, 1kHz, 2.5kHz, 6.3kHz, and 16kHz.

By making certain frequency ranges louder or softer, you can change the sound to suit your taste. You can also choose from six pre-programmed SEA settings.

Controlling Sound with the SEA Function

1. Press the **SEA** button on the Amplifier.



The SEA indicator lights up.

2. Press the **FREQUENCY** ◀ or ▶ button on the Amplifier to select one of the seven frequency ranges to work on.

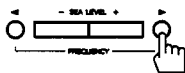

Press the **FREQUENCY** ▶ button to select the next higher frequency and the ◀ button for the next lower frequency.

3. Press the **SEA LEVEL** button (+ or -) on the Amplifier to set the level for the selected frequency range.

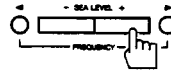

- Press the + button to increase sounds in the selected frequency range, and pressing the - button to decrease sounds in this frequency range.
- Repeat steps 2-3 for each frequency range.

Note: If you want to compare the new sound you have created with the way the system sounded before, press the **SEA** button on the Amplifier and listen to a selection of music. Then press the **SEA** button again to hear the new sound.

4. Press the **MEMORY** button on the Amplifier to store your SEA pattern in memory.



Using an SEA Pattern

You can use the SEA pattern you created, or one of the six pre-programmed SEA patterns, each of which has its own sound characteristics.

The pre-programmed SEA patterns are:

ROCK	Boosted low and high frequencies.
JAZZ	Gives a feeling of a live atmosphere. Good for acoustic music.
POPS	Good for vocal music.
CLASSIC	Set for wide and dynamic sound stereo systems.
H.PHONE	When creating tapes for headphone use.
CAR	When creating tapes for use in a car stereo.

1. Press the **SEA** button on the Amplifier.

The SEA indicator light goes on.

2. Press the **SEA PRESET** button to select an SEA Pattern.



Each press of the SEA PRESET button changes the pattern displayed in the following order:

- ▶ **ROCK** ▶ **JAZZ** ▶ **POPS** ▶ **CLASSIC** ▶ **H. PHONE**
- ▶ **CAR** ▶ **MANUAL** (back to the beginning)

Changing the SEA Display

The display on the amplifier indicates the sound being played back in seven frequency bands. Five display modes (**PEAK HOLD**, **PEAK LINE**, **SHOWER**, **MOUTH**, **SHUTTER**) are available. Every time the **DISPLAY** button is pressed, the display mode changes in the following order:



- ▶ **PEAK HOLD** ▶ **PEAK LINE** ▶ **SHOWER** ▶ **MOUTH**
- ▶ **SHUTTER** (back to the beginning)

Using Turntable, VCR and DAT

In addition to the CD Player, Tuner, and Cassette Tape Deck, the amplifier can also play a turntable, a VCR, and a DAT.

1. To play records, press the PHONO button on the Amplifier.
To play VCR or DAT, press the VCR/DAT button on the Amplifier.
2. To operate the each component, refer to its instruction manual.
 - You can operate a JVC VCR and DAT using the remote controller. See page 23 for more information.

Playing Back with a Surround Sound Effect

You can enjoy surround sound only with two speakers.

Press the SURROUND button.



The indicator light will go on.

Mixing the Microphone Sound

You can sing or narrate to the music with the optionally available microphone connected to the MIC jack.

1. Connect the microphone.
 - Set the MIXING LEVEL knob to SOURCE before connecting or disconnecting the microphone.
2. Play your desired source.
3. Adjust the volume balance between the music and microphone using the MIXING LEVEL knob.



Note: Raising the MIXING LEVEL too high may cause howling.

- Do not hold the microphone toward the speaker or move it away from the speaker.
- Lower the microphone level with the MIXING LEVEL knob.
- Lower the volume level with the VOLUME knob.

- When the microphone is not in use, set the MIXING LEVEL knob to SOURCE.

Using the LEARNING CSRP Feature

The LEARNING CSRP (Compu-link Source Related Preset system) is the state-of-art electronic feature that learns VOLUME and other control settings on each source. This was previously done automatically each time a difference source was played back or each time the system was turned off. It remembers the last five settings of each parameter you has set and automatically recalls the most frequently used ones.

This feature lets you invoke your favorite control settings by simply selecting a source (TAPE, TUNER, CD, VCR/DAT, PHONO) without repeating many settings each time sources are changed.

When the LEARNING CSRP button is set to ON, the following parameters are learned each time a difference source was played back or the system was turned off.

- Volume level
- SEA settings (Preset Pattern and display mode)

They will be set based on the last five settings.

- SEA ON/OFF
- SURROUND ON/OFF

They will be set to the last setting.

Press the LEARNING CSRP button



The indicator light will go on.

- When sources are switched, the VOLUME level, SEA, and SURROUND are automatically set.
- When turning the POWER off, the VOLUME control automatically turns toward MIN.
- When turning the POWER on again, the VOLUME control automatically turns up to the position set by the LEARNING CSRP function.

Using the Loudness Function

The loudness function will makes up for loss of the human auditory sensation when the sound is low.

1. Press the SEA button to turn the SEA on.
2. Press the SEA PRESET button to select a preset pattern other than MANUAL.
3. Press the LEARNING CSRP button.
The indicator light will go on.

- If the volume level is lowered:
Low and high frequencies are boosted to make the sound powerful and distinct.

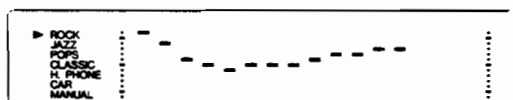

- If the volume level is raised:
The SEA setting becomes similar to the preset pattern and the sound becomes natural.

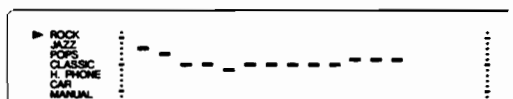

Using the CD Player

Starting Playback

1. Press the OPEN/CLOSE button on the CD Player.



The CD tray slides out.

2. Place a CD (with the label facing up) in the tray, and press the OPEN/CLOSE button again.

The tray slides back in.

3. Press the PLAY/PAUSE button on the CD Player, or the CD button on the Amplifier.



The CD Player begins playing the first track on the CD.

Stopping Playback and Ejecting the CD

1. Press the STOP/CLEAR button.



2. Press the OPEN/CLOSE button, and take the CD out of the tray.
3. Press the OPEN/CLOSE button again to close the tray.

Stopping and Restarting Playback

1. Press the PLAY/PAUSE button.

Playback stops temporarily.



2. Press the PLAY/PAUSE button again.

Playback restarts.

Note: When Tuner is selected as the source, Cd OFF is displayed, and only the OPEN/CLOSE disc tray and PLAY/PAUSE buttons can be used. To use other buttons, press the CD button on the Amplifier or the PLAY/PAUSE button on the CD Player first.

Selecting a Track to Play

Press the SEARCH buttons on the CD player to scan through the track numbers.

Press the  button to find tracks with decreasing numbers, and the  button to find tracks with increasing numbers.

- If you press the SEARCH buttons when the CD Player is in the pause/stop mode, you will find the track you selected. You can restart playback by pressing the PLAY/PAUSE button.
- If you press the SEARCH button continuously during playback, the CD will advance rapidly in the direction of the button.

Using the Remote Controller to Select a Track

There are three ways to search for a track with the remote controller:

Numeric keypad

AUTO SEARCH buttons  or 

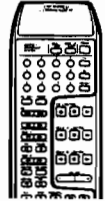

MANUAL SEARCH buttons  or 





Using the Numeric Keypad

1. Press the CD 10KEY button on the Remote Controller.
2. Enter the track's number with the numeric keys.
 - If the track you want to hear is the 8th track, press the 8 key.
 - If the track you want to hear is the 15th track, press the + 10 key and the 5 key.
 - If the track you want to hear is the 20th track, press the + 10 key and the 10 key.

Using the Auto Search Buttons

Press the Auto Search  or  button on the Remote Controller to scan through the track numbers.

Using the Manual Search Buttons

Press the Manual Search  or  buttons on the Remote Controller to search for a certain part of the track.

Listening Repeatedly

Using the REPEAT button, you can play the entire CD or a selected track repeatedly.



Playing the Entire CD Repeatedly

- During playback, press the REPEAT button once.

REPEAT

The CD will play through the last track and then start over again. It will keep repeating until you cancel the repetition.

Playing a Selected Track Repeatedly

- During playback, press the REPEAT button twice.

REPEAT 1

The current track will play to the end and then start over again. It will keep repeating until you cancel the repetition.

Cancelling Repetition

Press the REPEAT button again. Each track will play to the end and not repeat.

Displaying the Elapsed and Remaining Playing Time

Using the DISPLAY button, you can display the total time the CD (or current track) has been playing, and the amount of time that remains. This is useful in situations such as recording, when you need to know how long the track or CD has been playing, or the amount of time that remains on the track or CD.

Press the DISPLAY button to show the time you want.



There are four display times:

EACH	The total elapsed playing time since the beginning of playback of the current track
EACH REMAIN	The time remaining until the end of the current track
TOTAL	The total elapsed playing time since the beginning of playback of the CD
TOTAL REMAIN	The time remaining until the end of the CD

The display changes each time you press the DISPLAY button.

For Example:

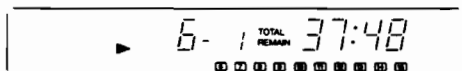

Display mode:	TOTAL REMAIN
Current track:	6th
Total remaining time:	37 minutes 48 seconds

Programming Your Own Playback Sequence

You can program the CD Player to play back the tracks of a CD in any order.

1. Press the STOP/CLEAR button on the CD Player.

This puts the CD Player in STOP mode and clears existing programs from the memory.

2. Press the PROGRAM button.



3. Press the CD 10KEY button on the Remote Controller.

4. Enter the track numbers with the numeric keys in the order you want them played back.

- You can program up to 32 tracks.

If the total time of all the programmed tracks is 100 minutes or more, the display will show "—:—:—" (since the highest time the display can show is "99:59").

5. Press the PLAY/PAUSE button on the CD Player, or the CD CONTROL button on the Remote Controller.

Playback begins with the first track in the program.

6. To add a track to the program during playback, enter the track number with the numeric keys on the Remote Controller.

The new track is added to the end of the program.

Checking the Program

You can check the programmed sequence of playback to determine which tracks will be played in which order.

Note: The program contents cannot be displayed during playback. Press the STOP/CLEAR button if the CD Player is in play mode.

1. Press the SEARCH button once.

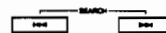

The first track in the program is displayed, along with its sequence number.

For example:

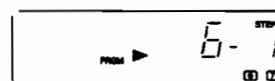

This display shows that the 6th track will be played first.

2. Press the SEARCH button repeatedly.

The rest of the tracks in the program are displayed, along with their sequence numbers.

Listening to Programmed Tracks Repeatedly

1. Press the REPEAT button to listen to the programmed sequence of playback repeatedly.



2. Then press the PLAY/PAUSE button.

Updating the Program

You can add and delete tracks from the program.

Adding Tracks to the Program

1. Press the CD 10KEY button on the Remote Controller.

2. Enter the track numbers with the numeric keys in the order you want them played back.

The track numbers you enter are added to the end of the program.

Deleting Tracks from the Program

Note: The program contents cannot be deleted during playback. Press the STOP/CLEAR button if the CD Player is in play mode.

1. Press the SEARCH buttons to select the track to be deleted from the program.

For example:

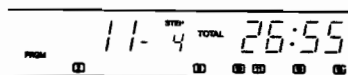

This display shows that the 11th track is selected to be deleted.

2. Press the CANCEL button on the Remote Controller.



- The track being displayed will be deleted.

Updating the Entire Program

You can replace the old program with a new one.

1. Press the **STOP/CLEAR** button on the CD Player.

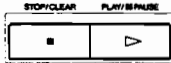

This clears the programmed sequence of playback from memory.

To clear the program during playback:

- Press the **STOP/CLEAR** button twice (once to stop, twice to clear the program from memory).

2. Press the **PROGRAM** button.
3. Press the **CD 10KEY** button on the Remote Controller.
Pressing the CD 10KEY button puts the numeric keys in CD mode.
4. Enter the track numbers with the numeric keys in the order you want them played back.

Cancelling Programmed Playback

1. Press the **PROGRAM** button.



This puts the CD Player in normal playback mode. The tracks will play back in their regular order.

Playing Tracks at Random

In **RANDOM** mode, the CD player selects and plays tracks at random.

1. Press the **RANDOM** button on the CD player.



CD player starts playing tracks at random.

2. To cancel random playback, press the **STOP/CLEAR** button.
 - When all tracks in the disc are played once, the random playback ends.
 - If you set the CD player to the **REPEAT** mode by pressing the **REPEAT** button, even after all tracks have been played once, the CD player will again select and play tracks at random to continue the random playback.

Using the **AUTO POWER OFF** Function

The power can be automatically turned off when the CD playback is completed.

1. Press the **AUTO POWER OFF** button on the CD player.



The indicator light will go on.

2. Press the **PLAY/PAUSE** button on the CD player or the **CD CONTROL** button on the Remote Controller.

The power goes off automatically when the CD playback is completed.

Using the Tape Deck

The tape deck has an Auto Tape Select feature, which can tell the difference between various types of cassette tape. It can distinguish between Normal (Type I), CrO₂ — High Position (Type II), and Metal (Type IV).

Playing a Tape

1. Press the EJECT button to open the cassette holder.
2. Insert a cassette and shut the cassette holder.
3. If the tape was recorded with Dolby noise reduction, use the DOLBY NR switch.

Set the switch to the same mode as the tape was recorded in.



4. Start playback by either of the following methods:

- Press the button.

Press the button if the tape is wound mostly on the left side.



Press the button if the tape is wound mostly on the right side.



- Press the TAPE button on the Amplifier.

Note: When cassettes are in both decks A and B, deck B starts first.

Stopping Playback and Ejecting the Tape

1. Press the STOP button on the tape deck.



2. Press the EJECT button to open and remove the tape from the cassette holder.
3. Shut the cassette holder.

Note: If the system is turned off while a tape is playing, you may not be able to eject the tape. You will need to turn the system back on and press the EJECT button to open the cassette holder.

Stopping and Restarting Playback

1. Press the PAUSE button on the tape deck.



Playback of the tape in deck B stops temporarily.

Note: The PAUSE button only applies to deck B.

2. Press the button.

This restarts playback of the tape in deck B.

Changing the Playback Direction

1. To change the playback direction during playback, press the button.

The other side of the tape will now play.

2. To change the playback direction without starting playback, press the button while also pressing the stop button.

This allows you to set the tape direction for a timed recording.

Fast-Winding the Tape

Press the or buttons on the Tape Deck to advance the tape rapidly in the direction of the arrows.

Listening to Tape Continuously

You can set the tape deck up to play both sides of the tapes in decks A and B repeatedly.

1. Insert cassettes into decks A and B.
2. Set the REV.MODE switch to (auto reverse) position.

non reverse → auto reverse

- The tape deck will be placed in auto reverse mode, which means that it will play all of one side of the tape and then all of the other side.

3. Press the button of the deck to be started first.

- Now both sides of both tapes will play repeatedly.
- After playback in reverse direction ends, the playing deck (A or B) will be switched to the other deck.
- If the tape deck is not placed in auto reverse mode, only one side of the tapes in decks A and B will play continuously.
- If you press the TAPE button on the Amplifier, deck B will start first.

Skipping Blanks

When there is a blank of 10 seconds or more, the tape skips forward to the beginning of the next track.

1. Press the BLANK SKIP button on the tape deck.



2. Press the button.

Blank Skip playback starts.

The BLANK SKIP function is not effective:

- When the track contains an area of low sound level.
- When the blank between tracks is short.
- When there is noise, for example, a hum between tracks.

Music Scanning

The music scan function will detect the blank segments between tracks. The blank should be about 4 seconds long for the music scan to be effective.

You can locate the beginning of the current track or next track quickly by pressing the playback button and the fast-winding button simultaneously.

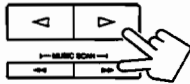

Searching for Beginning of the Current Track

- If the tape is travelling in the forward direction, press the **◀** fast-winding button while simultaneously pressing the **▶** playback button.
- If the tape is travelling in the reverse direction, press the **▶** fast-winding button while simultaneously pressing the **◀** playback button.

Searching for Beginning of the Next Track

- If the tape is travelling in the forward direction, press the **▶** fast-winding button while simultaneously pressing the **▶** playback button.
- If the tape is travelling in the reverse direction, press the **◀** fast-winding button while simultaneously pressing the **◀** playback button.

Note: The deck that is playing will stop if the music scan function is used on the other deck.

The music scan function is not effective:

- When the track being scanned contains an area of low sound level.
- When the blank between tracks is short.
- When there is noise, for example, a hum between tracks.

Recording a Tape

The recording system uses Dolby HX PRO to improve the high-frequency characteristic and to reduce level fluctuations at low frequencies. You will enjoy dynamic recording ranging from low through high frequencies.

Note: No switch operation or operation at playback is needed.

Recording Notes:

- Deck A is used for playback only, and deck B is used for both recording and playback.
- To reduce hiss, use the Dolby noise reduction system. Set the DOLBY NR switch to B or C.

B: Popular noise reduction

C: Highly effective noise reduction



- To dub both sides of tape, set the REV MODE switch to the auto reverse position (), and start dubbing in the forward direction (**▶**) for both decks A and B.
- The recording level is set automatically.
- If the small tabs on cassette tapes to prevent accidental erasure have been removed, the contents of the tape cannot be recorded or erased over. To record or erase, cover the holes with adhesive tape. (The tab in the upper left corner is the tab for the side facing you, and the other tab is for the opposite side.)
- If you are recording an AM broadcast and you hear interference, move the BEAT CUT switch on the back of the stereo from Position 1 (the normal mode) to Position 2.

Recording from Various Sources

1. Insert a cassette for recording into deck B.
2. Select the source you are recording from TAPE (Deck A), TUNER, CD, VCR/DAT, PHONO.
3. Press the **Pause**  button on the Tape Deck while simultaneously pressing the **REC/REC MUTE** button.



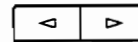

This puts the deck B in REC/PAUSE mode.

4. Start the source to be recorded.
5. Press the **Play** **◀** or **▶** button on deck B to start recording.



To record on both sides of tape, start recording in the forward (**▶**) direction.

6. To stop recording, press the **Stop**  button.
7. To stop recording temporarily, press the **Pause**  button on deck B. To restart recording again, press the **Play** button **◀** or **▶**.

Dubbing a Tape

Normal-Speed Dubbing

1. Insert the cassette for playback into deck A and the cassette for recording into deck B.

- The type of tape (Normal, CrO₂, or Metal) used for recording must be the same as that used for playback.
- To dub a tape which was recorded with Dolby noise reduction, set the DOLBY NR switch on the Tape Deck and the SEA button on the Amplifier to the OFF position.

2. Press the **Pause**  button while simultaneously pressing the **REC/REC MUTE** button on deck B.

This places deck B in REC/PAUSE mode.

3. Press the **Play** button **◀** or **▶** (depending on which side of the tape you want to record from) on deck A.
4. Press the **Play** button **◀** or **▶** (depending on which side of the tape you want to record onto) on deck B.

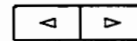



The tape-to-tape recording starts.

Note: You cannot listen to another source during normal-speed dubbing.

- To stop normal-speed dubbing before the end of either the playback or record tape, press the **Stop**  buttons on decks A and B.

High-Speed Dubbing

1. Insert the cassette for playback into deck A and the cassette for recording into deck B.

- To change the playback direction of deck A, hold down the Stop  button and press the  or  button.

2. Press the HIGH SPEED DUBBING button on the Tape Deck.



- The high-speed tape-to-tape recording starts.

Note: You can listen to another source while high-speed dubbing is in progress.



- To stop high-speed dubbing before reaching the end of either the playback or record tape, press the Stop  button on deck B.

Note: If a nearby television is on during high-speed dubbing, a beeping noise may be recorded onto the record tape. Turn off the television or move it farther away.

3. Press the Stop  button on deck A when you hear the end of a track to record from many different tapes (for example, to create a "Greatest Hits" tape)



Deck A stops playback, and deck B automatically creates about a 4 second blank, then pauses.

Note: If you don't want this blank, press the PAUSE  button on deck B before pressing the Stop  button.

4. Put another tape into deck A.

5. Press the HIGH SPEED DUBBING button on the Tape Deck.

The high-speed dubbing restarts.

6. To record tracks from other tapes, repeat steps 3 - 5.

- The SEA Function is not effective during high-speed dubbing.

Note: It may be unlawful to record or playback copyrighted material without the consent of the copyright owner.

Erasing a Tape

1. Insert the tape to be erased into deck B.

- To erase music on both sides, set the REV.MODE switch to the auto reverse position.

2. Press the Pause  button while simultaneously pressing the REC/REC MUTE button.

This puts the deck in REC/PAUSE mode.

3. Press the TAPE button on the Amplifier.

4. Press the  or  button (depending on which side of the tape you want to erase) on deck B.

The erasure of the tape begins.

Direct Recording from the CD Player

Direct recording permits a tapedeck to start recording automatically in synchronism with a CD player.

1. Insert the cassette for recording into deck B.

- Set the REV.MODE switch to Auto reverse  position if you want to record on both sides of the cassette.

2. Put a CD in the CD Player.

3. Press the CD DIRECT REC button on the Tape Deck.



- The CD Player and the Tape Deck are activated, and recording begins with the first track of the CD.
- To stop direct recording, press the Stop  button on deck B or the STOP/CLEAR button on the CD Player.

4. To fade out the CD gradually at the end of the tape, press the FADE button on the CD Player.



The volume level of the last track on the tape is lowered gradually to 0. This makes a nice ending to your tape and prevents an abrupt cut-off of music if the tape ends before the CD.

5. To cancel the fade-out function during recording, press the FADE button again on the CD Player.

The fade-out function operates in both forward and reverse directions.

- When the end of the tape is reached, the tape is rewound to the beginning of the last track.
- The last track is played back again from the CD Player and recorded again on the tape. This time the sound level is reduced gradually at the end.

Dolby noise reduction and HX PRO headroom extension manufactured under license from Dolby Laboratories Licensing Corporation. HX PRO originated by Bang and Olufsen. "Dolby", the Double-D symbol and HX PRO are trademarks of Dolby Laboratories Licensing Corporation.

Recording CD Tracks in Auto-Edit Mode

In Auto-Edit mode, tracks from the CD will automatically be selected to determine which tracks should go on side A of the tape and which should go on side B.

The selection is based on the lengths of the tracks and the length of the tape. This ensures a proper "fit" of the tracks recorded on the tape. It prevents a track from being cut off when the end of the tape is reached.

1. Insert the cassette for recording in deck B.

- Set the REV. MODE switch to the Auto reverse  position if you want to record on both sides of the cassette.

2. Put the CD in the CD Player.

3. Press the STOP/CLEAR button on the CD Player.

4. Press the A. EDIT button on the CD Player to tell the system the length of the tape in the Tape Deck.



- The tape length most suitable for CD recording is displayed first.
- Each time the A.EDIT button is pressed, the next standard tape length blinks, in this order:

▶C46▶C54▶C60▶C74▶C90▶ (back to the beginning)

- You can also enter a non-standard tape length from the Remote Controller using the numeric keys.

For example: To enter a tape length of 50 minutes, press the CD 10KEY button on the Remote Controller, then press the +10 key four times and the 10 key once.

5. Press the SIDE A/B button on the Remote Controller.

- The CD Player calculates which tracks should be placed on side A and which should be placed on side B, based on the lengths of the tracks and the length of the tape.
- If you do not press the SIDE A/B button, the CD Player automatically decides which tracks should be placed on sides A and B about 4 seconds after the A. EDIT button is pressed.

Note: Up to 16 tracks can be allocated for each side of the cassette.

6. Press the CD DIRECT REC button on the Tape Deck.



- The tape is automatically rewound to the beginning of side A, and then recording begins.
- When the Tape Deck is set in the auto reverse mode, after the last track is recorded on side A, the tape deck high-speed-erases to the end of side A. Then it changes direction to side B and begins recording the remaining tracks.
- To stop recording, press the Stop  button on deck B, or press the STOP/CLEAR button on the CD Player.

Note: During recording in the Auto-Edit Mode, do not operate the CD Player.

Recording CD Tracks in Programmed-Edit Mode

In Programmed-Edit Mode, you decide which tracks from the CD will be recorded, and in what order.

1. Insert the cassette for recording in deck B.

- Set the REV. MODE switch to the Auto reverse  position if you want to record on both sides of the cassette.

2. Put the CD in the CD Player.

3. Press the STOP/CLEAR button on the CD Player.

4. Press the PROG. EDIT button on the Remote Controller to tell the system the length of the tape in the Tape Deck.



- Each time the PROG. EDIT button is pressed, the next standard tape length blinks, in this order:

▶ C46 ▶ C54 ▶ C60 ▶ C74 ▶ C90 ▶ (back to the beginning)

- You can enter a non-standard tape length from the Remote Controller using the numeric keys.

For example: To enter a tape length of 50 minutes, press the CD 10KEY button on the Remote Controller. Then press the +10 key four times and the 10 key once.

5. Press the SIDE A/B button on the Remote Controller.



- This tells the system that you will be choosing tracks to be recorded on side A of the tape.
- The length of time for one side of the tape is displayed. This is half of the total tape length. The total time for the tracks you choose for each side cannot exceed this time.
- If you do not press the SIDE A/B button, side A is automatically selected.

6. Press the CD 10KEY button on the Remote Controller.

7. Enter the numbers of the tracks you want recorded on one side of the tape.

- Tracks on a CD assigned numbers 32 or greater cannot be entered in the program.
- If the length of a track exceeds the remaining tape length, the time indication blinks on the display. Choose a different track number.
- To delete a track from the program, specify the track with the ALTO SEARCH buttons on the Remote Controller. Then press the CANCEL button on the Remote Controller.

8. If you also want to record on the other side of the tape, press the SIDE A/B button on the Remote Controller and repeat step 7.

9. Press the CD DIRECT REC button on the Tape Deck.



- The tape is automatically rewound to the beginning of side A, and then recording begins.
- When the Tape Deck is set in auto reverse mode, after the last track is recorded on side A, the tape deck high-speed-erases to the end of side A. Then it changes direction to side B and begins recording the remaining tracks.
- To stop recording, press the STOP button on deck B, or press the STOP/CLEAR button on the CD Player.

Note: The program cannot be edited during recording. To change the program, press the STOP/CLEAR button on the CD Player and begin with step 4 of this procedure.

Note: During recording in the Programmed-Edit Mode, do not operate the CD Player.

Recording with the SEA Function

The SEA Function is used to alter the tone of the source by increasing or decreasing the levels of selected frequency ranges.

You can use this function to control the way the tracks from the CD will sound when they are recorded on the tape.

1. **Insert the cassette for recording in deck B.**
2. **Press the SEA button on the Amplifier.**
 - The indicator light will go on.
 - To create the desired sound, see "Controlling Sound with the SEA Function" on page 9.
3. **Press the < or > button on the Tape Deck while holding down the REC/REC MUTE button.**

Recording starts.

SEA Function Notes

- The SEA Function cannot be used during high-speed dubbing.
- If the source you are recording from is a cassette in deck A that was created using Dolby noise reduction, the noise reduction effect is lost when you dub using the SEA Function.
- To keep the noise reduction effect of the cassette in deck A, use either of these methods:
 - High-speed dubbing.
 - Normal speed dubbing, with the SEA Function off and the DOLBY NR button set to OFF.
- When LEARNING CSRP is ON, do not change the volume level during recording because the loudness feature will cause the SEA settings to be altered.

Creating a Blank During Recording

Use the Record Muting function when you do not want to record a section of the source.

1. **Press the REC/REC MUTE button on the Tape Deck at the beginning of the section you don't want to record.**



A blank of about 4 seconds is created on the cassette, and then the deck pauses.

2. **To start recording again, press the < or > button.**

- To create a blank of more than 4 seconds, hold down the REC/REC MUTE button. When you release this button, the deck pauses.
- When the source you are recording from is the CD Player and the CD DIRECT REC button is used, the REC/REC MUTE button will not function.

Recording with the Timer

This compact component system can be set up to record a tape automatically. This is especially useful for recording broadcasts when you are not around, or late at night when you are asleep.

1. **Insert a cassette for recording into deck B.**
2. **Set the timer, by following the steps in "Setting the Timers" on page 18.**
3. **Select one of the following sources:**

TUNER TIMER REC
— — TIMER REC

Records TUNER preset stations
Records from the source selected before turning off the system

Using the Tuner

Listening to Broadcasts

The Tuner can receive FM and AM broadcasts. Stations can be tuned in manually, automatically, or from preset memory storage.

Manual Tuning

1. Select the broadcast band you want to tune in by pressing the FM or AM button on the Tuner.

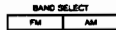

2. Press the TUNING/TIMER/DIMMER button (< or >) to tune in a station.

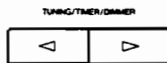

3. Hold down the TUNING/TIMER/DIMMER button to change the frequency rapidly, then tap the button to set the frequency precisely.

Automatic Tuning

1. Select the broadcast band you want to tune in by pressing the FM or AM button on the Tuner.
2. Hold down the TUNING/TIMER/DIMMER button (< or >) for a moment, and then release the button.

- When a station is tuned in, the TUNED indicator lights up.

Note: The Tuner will tune in the nearest strong station.

Presetting Stations in Memory

You can store up to 40 of your favorite radio stations (FM and AM) in memory, giving you quick, easy access to the stations.

1. Select a band by pressing either the FM or AM button on the Tuner.
2. Press the TUNING/TIMER/DIMMER button (< or >) to tune in a station.
3. Press the MEMORY button on the Tuner.



The "MEMORY" indicator on the Tuner display blinks for 5 seconds.

4. Press the PRESET button (< or >) on the Tuner to assign a number (1-40) to the station, or enter a number (1-40) with the Remote Controller's numeric keypad.

Example:

To enter 7, press "7".
 To enter 17, press "+10", then "7".
 To enter 20, press "+10", then "10".

- To enter a number with the numeric keypad, you must press the FM or AM button on the remote controller first.
- If the "MEMORY" indicator has stopped blinking, press the MEMORY button again and repeat step 4.
- If the preset number you choose already has a station assigned to it, the old station will be replaced by the new one.

5. Press the MEMORY button again.

This stores the station in memory, with the preset number (1-40) you chose in step 4.

6. Repeat steps 1-5 for each station you want to store in memory with a preset number.

Caution! If the system is unplugged or if a power failure occurs, the preset stations stored in memory may be lost.

Cancelling Preset Stations

1. Press the CANCEL button on the Tuner.



The "CANCEL" light on the Tuner display blinks for 5 seconds.

2. Press the PRESET button (< or >) on the Tuner to select the preset station you want to cancel.

If the "CANCEL" light has stopped blinking, press the CANCEL button again and repeat step 2.

3. Press the CANCEL button again.

The preset station will be cancelled.

Tuning in Preset Stations

- Press the PRESET button (< or >) on the Tuner to select the preset station you want. The preset station numbers are displayed sequentially each time you press the PRESET button.
- You can also select a station by entering its preset number on the Remote Controller's numeric keypad.

FM Reception Modes

There are two FM reception modes: AUTO and MONO.

AUTO: Stations are tuned in with either STEREO or MONO, depending on the strength of the FM signal.

MONO: Stations are tuned in with MONO only. This will reduce interference noise of weak stations and make the reception sound better.

1. Press the FM MODE/MUTE button on the Tuner to switch between the AUTO and MONO reception modes.



2. Press the FM MODE/MUTE button on the Tuner to the AUTO mode to receive the station in stereo.

- If a stereo broadcast is received when the FM band is selected, the "STEREO" light will be displayed on the Tuner.
- If the FM Reception Mode is MONO, the "STEREO" light will not be displayed.

Using the Timers

Setting the Clock

The clock will be displayed even when the system is turned off. Pressing the TUNING/TIMER/DIMMER buttons (< or >) will switch between two brightness levels for the clock.

1. Press the **CLOCK ADJUST** button on the Tuner.



The hours digits blink.

2. Press the **TUNING/TIMER/DIMMER** button (< or >) to set the hours digit.



- Press the > button to increase the hour, and press the < button to decrease the hours.
- To enter a new hour digit, press the CANCEL button and repeat step 2.



3. Press the **MEMORY** button on the Tuner.



This sets the hour portion of the time.

The minutes digits will blink.

4. Press the **TUNING/TIMER/DIMMER** button (< or >) to set the minutes digit.

- It's a good idea to set the minutes digits one minute ahead. Then you can start the clock when it reaches the set time exactly (according to the correct time from the TV, radio, or telephone).
- To enter a new minute digit, press the CANCEL button and repeat step 4.

5. Press the **MEMORY** button.

The clock starts as soon as you press the MEMORY button.

Caution: If there is a power failure, or if you unplug the stereo, the clock time will be lost. Repeat steps 1-5 when power is restored.

- Use the TUNING/TIMER/DIMMER buttons to change luminosity of time display by two steps under STANDBY status.

Setting the Timers

This system has three timers (**TIMER 1, TIMER 2, DAILY**) that are used to turn the system on and off automatically:

With the timers you can make tape recordings of broadcasts, CD's, or tapes when you're not around. You can also play these music sources at specified times without recording them.

- Use TIMER1 and TIMER2 to record a radio broadcast when you're not home, or late at night when you're asleep.
- Use the DAILY timer to record a broadcast that occurs at the same time every day.
- The procedure for setting TIMER1, TIMER2, and the DAILY timer is the same. You need to tell the system:
 - The name of the timer (TIMER1, TIMER2, or DAILY).
 - The time the timer should turn the system on.
 - The time the timer should turn the system off.
 - The source the timer should turn on (Tuner, CD, or Tape).
 - The volume level that should be used during recording or playback.

Note: The clock must be set to the correct time for the timers to be effective.

Caution! Do not operate the remote controller when you are programming the timer.

Choosing a Timer

Press the TIMER1, TIMER2, or DAILY button on the Tuner to select a timer. This puts the system in the Timer Setting mode. The information that the system expects next will blink on the display.

Setting the Start Time

1. Press the **TUNING/TIMER/DIMMER** buttons to set the hour that the system will turn on.

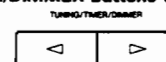

The < button makes the hour number decrease, and the > button makes the hour number increase.

2. Press the **MEMORY** button.



This stores the hour portion of the start-time in memory.

3. Press the **TUNING/TIMER/DIMMER** buttons to set the minutes.

4. Press the **MEMORY** button.

This stores the minute portion of the start-time in memory.

Setting the Stop Time

1. Press the **TUNING/TIMER/DIMMER** buttons to set the hour that the system will turn off.
2. Press the **MEMORY** button.

This stores the hour portion of the stop-time in memory.

3. Press the **TUNING/TIMER/DIMMER** buttons to set the minute.
4. Press the **MEMORY** button.

This stores the minute portion of the stop time in memory.

Selecting the Source

1. Press the **TUNING/TIMER/DIMMER** button to select a source.

Repeatedly pressing the **▷** button displays the sources in the following order:

Display	What it means
-- --	Plays from whichever source was used just before turning off the system
TUNER	Plays FM or AM broadcast
TUNER TIMER REC	Records FM or AM broadcast
CD	Plays a CD
TAPE	Plays a tape
-- --TIMER REC	Records from whichever source was used just before turning off the system

Note: If you choose an FM or AM radio station as the source, select the preset station by pressing the **PRESET** button on the Tuner.

2. Press the **MEMORY** button.
This stores the source to play or record in memory.

Setting the Volume

1. Press the **TUNING/TIMER/DIMMER** button to select a volume level.
Repeatedly pressing the **▷** button displays the volume levels in the following order:

Display	What It Means
VOL --	Volume set to the level used before shut the power off.
VOL -- 0	Volume off
VOL -- A	Volume barely on
VOL -- B	Volume at 1/4 power
VOL -- C	Volume at 1/3 power

2. Press the **MEMORY** button.
This stores the volume level for timed playback or recording in memory.

Starting the Timer

Press the **Timer** button to start the timer. The timer you chose should light on the display.

Note: If the timer light does not light, the timer was not set properly, and you need to set the start time again.
To change your selection, press the **CANCEL** button and enter a new value.

Turning the System Off

Press the **POWER** button on the Amplifier to turn the system off.



- The system is now programmed to turn on at the preset start-time, and play or record until the stop-time.
- It will record or play the preset source at the preset volume level until the stop-time is reached.
- If you turn the system on before the start-time, the timer will still operate as programmed at the start-time.

Resetting the Timers

To reset a timer, press the button (**TIMER1**, **TIMER2**, or **DAILY**) on the Tuner twice. Now the timer is set again and will use the same start-time, stop-time, source, and volume level as before.

Setting the Wake-Up and Sleep Timers

You can set a timer so it turns on to wake you up or turns off when you go to sleep.

Setting the Wake-Up Timer

The wake-up timer serves as an alarm clock. It turns the system on after a programmed time lapse and plays the source that was used before the system was turned off. You can set a wake-up time from between 5 minutes and 12 hours.

1. Press the **POWER** switch on the Amplifier so it is off.
2. Press the **WAKE UP/SLEEP** button on the Tuner.



This tells the system that you are going to set the wake-up time.

3. Press the **WAKE UP/SLEEP** button repeatedly until the desired wake-up time appears.

Each time you press the **WAKE UP/SLEEP** button, the wake-up time lapse changes in the following order:

▶0:05▶0:10▶0:15▶0:30▶0:45▶1:00▶1:30▶2:00▶3:00▶ (every hour) ▶12:00▶ (back to the beginning)

- If you make a mistake, press the **CANCEL** button on the Tuner and enter a new wake-up time with the **WAKE UP/SLEEP** button.

The system will now turn on after this time lapse.

- The wake-up timer has priority over **TIMER1**, **TIMER2**, and the **DAILY** timer.
This means that if the start-time for one of the timers occurs before the wake-up time, the system will wait until the wake-up time to turn on.

Note: If CD is the source that will be used, playback begins with the first track.

Setting the Sleep Timer

The sleep timer is used to turn off the system after a specified time lapse. With this timer you can fall asleep listening to music, knowing that the system will shut off automatically and not stay on all night. You can set the sleep timer to turn the system off from between 5 minutes and 2 hours

1. Press the **POWER** switch on the Amplifier so it is on.
2. Start the source you want to listen to.
3. Press the **WAKE UP/SLEEP** button on the Tuner.



This tells the system that you are going to set the sleep time.

4. Press the **WAKE UP/SLEEP** button repeatedly until the desired sleep time appears.

Each time you press the **WAKE UP/SLEEP** button, the sleep time lapse changes in the following order:

▶0:05▶0:10▶0:15▶0:30▶0:45▶1:00▶1:15▶1:30▶1:45▶2:00▶
(back to the beginning)

- If you make a mistake, press the **CANCEL** button on the Tuner and enter a new sleep time with the **WAKE UP/SLEEP** button.

The system will now turn off after this time lapse.

- The sleep timer has priority over **TIMER1**, **TIMER2**, and the **DAILY** timer.

This means that if the stop-time for one of the timers occurs before the sleep time, the system will wait until the sleep time before turning itself off.

Checking the Remaining Time

After setting the wake-up or sleep timer, you can check the time remaining until the system turns on (wake-up time) or shuts off (sleep time).

Press the WAKE UP/SLEEP button.

The remaining time is displayed for 5 seconds. Then the clock time appears again.

Adding More Time

If you want more time before the wake-up timer turns the system on (or the sleep timer turns the system off), follow these steps:

1. Press the **WAKE UP/SLEEP** button.

The remaining time is displayed for 5 seconds. Then the clock time appears again.

2. Press the **WAKE UP/SLEEP** button again before the clock time is displayed.

- Keep pressing this button until the desired additional time is reached.

Now the system will wait until the added amount of time until turning on or shutting off.

Cancelling the Time Setting

If you decide you don't want the system to wake you up or play music while you fall asleep, you can turn these timers off.

1. To cancel the wake-up timer, press the **POWER** button on the Amplifier.



This turns the power on.

2. To cancel the sleep timer, press the **POWER** button on the Amplifier.

This turns the power off.

Using the Remote Controller

Operating the Remote Controller

You can use the Remote Controller to operate the system without leaving your chair. You can use it up to a distance of 23 feet.

Point the Remote Controller at the remote sensor on the Amplifier.

Note: When the Tuner is Selected as the source, and Cd OFF is displayed, only the OPEN/CLOSE and PLAY buttons on the Remote Controller can be used.

To use other buttons on the Remote Controller (for programming and other operations), press the CD button on the Amplifier or the CD PLAY button on the Remote Controller first.

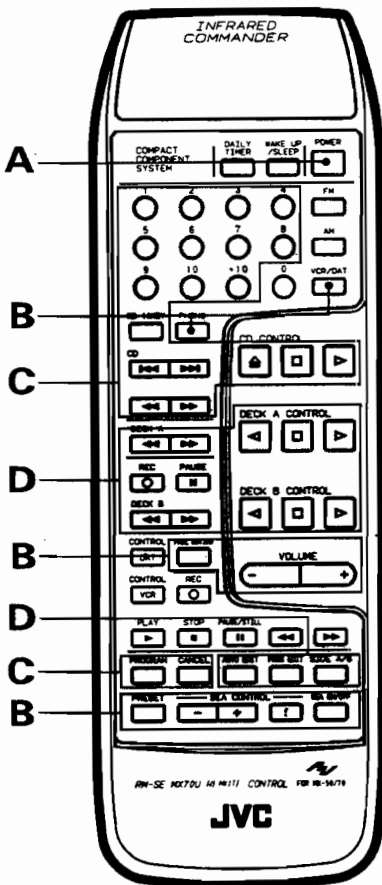
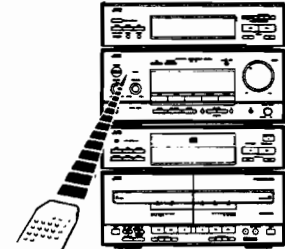

Function	Button(s) To Use
A Turn power on or off	[POWER]
B Amplifier	
Adjust volume level	[VOLUME]
Lower volume level gradually to 0	[VOLUME] + [VOLUME]
Listen to VCR or DAT	[VCR/DAT]
Listen to records	[RECORDS]
Turning SEA Function on or off	[SEA]
Selecting a frequency range for the SEA Function	[SEA] + [FM]
Setting a SEA level	[SEA] + [FM]
Using a SEA pattern	[SEA] + [FM]
C CD Player	
Open and close the disc tray	[CD]
Play a CD	[CD]
Stop playback of a CD	[STOP]
Place numeric keys in CD mode	[NUMERIC KEYS]
Select track number	[NUMERIC KEYS]
Scanning through the track numbers	[SCAN]
Search for a certain part of the track	[SEARCH]
Program playback order	[PROGRAM]
Cancelling a program	[CANCEL]
D Tape Deck	
(Press buttons corresponding to the deck being used, either deck A or B)	
Play a tape in forward direction	[PLAY]
Play a tape in reverse direction	[REVERSE]
Stop playback temporarily (deck B)	[STOP]
Stop playback	[STOP]
Fast forwarding or fast rewinding	[FF]
Search for beginning of the track while in forward direction	[FF] + [SEARCH]
Search for beginning of the track while in reverse direction	[REVERSE] + [SEARCH]
Recording in forward direction	[RECORD] + [PLAY]
Recording in reverse direction	[RECORD] + [REVERSE]
Pausing recording	[RECORD] + [STOP]
Restarting recording in forward direction	[RECORD] + [PLAY]
Restarting recording in reverse direction	[RECORD] + [REVERSE]
Stopping recording	[STOP]
Recording from CD in the Auto-Edit mode	[CD] + [RECORD]
Recording from CD in the Programmed-Edit mode	[CD] + [RECORD]

Note: Where '+' is indicated, press and hold the first button illustrated, then press the second.

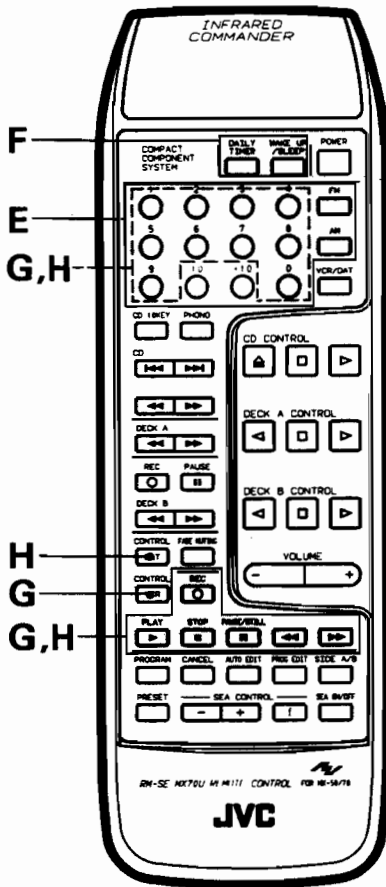

Function

Button(s) To Use

E	Tuner	
	Selecting Tuner mode / Selecting a band	
	Selecting a preset station	
F	Timers	
	Setting/resetting the DAILY timer	
	Setting the wake-up/sleep timer	
G	VCR	
	First select VCR mode	
	Recording	+
	Play a tape	
	Stop playback	
	Stop recording or playback temporarily	
	Rewind the tape	
	Fast forwarding	
	Select a TV channel	
	<ul style="list-style-type: none"> ■ When using the remote controller to operate a VCR, point the controller at the VCR. ■ The numeric keys may have different functions depending on the JVC model VCR you have. See your VCR's manual for operating instructions. 	
H	DAT	
	First select DAT mode	
	Recording	+
	Play a tape	
	Stop playback	
	Stop recording or playback temporarily	
	Rewind the tape	
	Fast forwarding	
	Select a track number for playback	
	<ul style="list-style-type: none"> ■ When using the remote controller to operate a DAT, point the controller at the DAT. ■ The numeric keys may have different functions depending on the JVC model DAT you have. See your DAT's manual for operating instructions. 	

Troubleshooting

Symptom	Possible Cause	Action
No sound is heard.	Speakers are connected incorrectly.	Re-connect speakers (see "Connecting the System Component" on page 6).
Impossible to record.	Tape tabs are broken out.	Cover tabs with adhesive tape.
Interference during broadcast.	Antenna is disconnected. The loop antenna is too close to the system.	Re-connect the antenna securely. Change the position and direction of the loop antenna.
CD sound is discontinuous.	The CD is scratched or stained.	Clean or replace the CD.
The Remote Controller cannot be operated.	There is an obstruction blocking the remote sensor on the amplifier.	Remove the obstruction.
	The batteries of the Remote Controller are weak.	Replace the batteries.
The CD disc tray cannot be operated.	The power plug is disconnected.	Connect the power plug securely.
	The POWER button is set to STANDBY.	Set the POWER button to ON.
The CD does not play.	The CD is in the tray upside down.	Put the CD in the tray with the label side facing up.
Operations are disabled.	The built-in microprocessor may malfunction due to external electrical interference.	Unplug the system, then plug it back in.
The cassette holder cannot be opened.	The system was turned off because the timer was operated while the tape was running.	Turn on the system.

Specifications

Amplifier

Output Power
SPEAKERS A **23 watts per channel, min. RMS, both channels driven into 8 ohms, from 40 Hz to 20 kHz, with no more than 0.9% total harmonic distortion.**

SPEAKERS B 27 watts per channel into 6 ohms at 80 Hz with 0.9 % total harmonic distortion.

Total Harmonic Distortion at Half-Rated Power 0.07%

Input Sensitivity/
Impedance (1kHz)
VCR/DAT 300mV/40k ohms
PHONO 3mV/47k ohms

SEA Center Frequencies 63, 160, 400, 1k, 2.5k, 6.3k, 16kHz

SEA Control Range ± 12dB

Dimensions 10-7/8 x 4-9/16 x 11-1/2 inches
(275 x 115 x 291 mm)

Weight 10.8 lbs (4.9 kg)

Compact Disc Player

Dynamic Range 90dB

Signal-to-Noise Ratio 100dB

Wow and Flutter Unmeasurable

Dimensions 10-7/8 x 2-11/16 x 10-7/16 inches
(275 x 68 x 265 mm)

Weight 4.5 lbs (2.0 kg)

Tape Deck

Frequency Response
Metal: 30 — 17,000Hz
CrO₂: 30 — 16,000Hz
Normal: 30 — 15,000Hz

Wow and Flutter (WRMS) 0.09%

Dimensions 10-7/8 x 4-9/16 x 10-1/2 inches
(275 x 115 x 266 mm)

Weight 6.2 lbs (2.8 kg)

Tuner

FM

Tuning range 87.5 MHz — 108.0 MHz

Usable Sensitivity 0.95µV/75 ohms (10.8dBf)

Signal-to-Noise Ratio (IHF-A Weighted/DIN)
MONO (at 85dBf) 80dB/72dB
STEREO (at 85dBf) 73dB/64dB

AM

Tuning range 530 kHz — 1,710 kHz

Dimensions 10-7/8 x 2-11/16 x 10-7/8 inches
(275 x 68 x 275 mm)

Weight 3.1 lbs (1.4 kg)

General

Power Requirements AC 120 V ~ 60 Hz

Power Consumption 190 W, 230 VA

Accessories

- FM Feeder antenna 1
- AM Loop antenna 1
- Speaker cable 2
- Remote Controller (RM-SEM70U) 1
- Batteries (UM-4/AAA/R03) 2

POWER SPECIFICATIONS

Area	Line Voltage & Frequency	Power Consumption
Canada	AC 120V ~ , 60Hz	190 watts , 230VA
U . K .	AC 240V ~ , 50Hz	365 watts
Australia		
Continental Europe	AC 230V ~ , 50Hz	160 watts
Other Area	AC 110 / 127 / 220 / 240V ~ , 50 / 60Hz	145 watts

AM Tuner

Tuning range
MW

Area	Channel Spase	
	9kHz	10kHz
Continental Europe, U . K . , Australia	522kHz ~1629kHz	---
Other Area	531kHz ~1602kHz	530kHz ~1600kHz

LW (CA-MX70BK, DX-MX70BK) 144kHz~353kHz

Design and specifications subject to change without notice .



VICTOR COMPANY OF JAPAN, LIMITED

Printed in Japan
0391SN1542 TD