

# JVC

## SERVICE MANUAL

### COMPACT COMPONENT SYSTEM

# CA-MX77MTN

(Unit No. DX-MX77MTN)

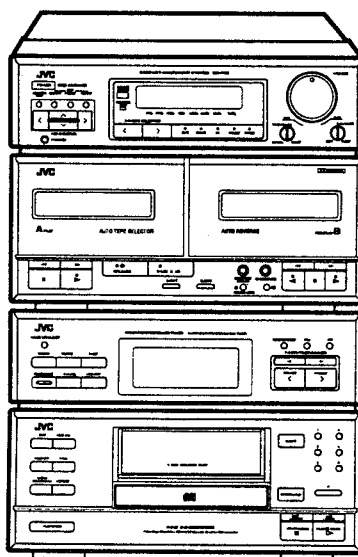

COMPACT  
**disc**  
DIGITAL AUDIO

〒103 東京都中央区日本橋本町4-8-14  
日本ビクター株式会社  
サービス部 部品管理課

- \* This unit should be connected with the XT-MX77MTN.
- \* Refer to the CA-MX77MTN service manual (No.20334) for Instruction manual and Packing materials.

## Contents

Safety Precautions .....	1-2	Block Diagrams .....	Insertion
Description of ICs .....	1-3	Schematic Diagrams .....	Insertion
Internal Connection		Printed Circuit Boards .....	Insertion
for the FL Display Tube .....	1-9	Parts List .....	Separate-volume Insertion
Disassembly Procedures .....	1-10		
Adjustment Procedures(Deck) .....	1-14		

## Safety Precautions

1. The design of this product contains special hardware and many circuits and components specially for safety purposes. For continued protection, no changes should be made to the original design unless authorized in writing by the manufacturer. Replacement parts must be identical to those used in the original circuits. Services should be performed by qualified personnel only.
2. Alterations of the design or circuitry of the product should not be made. Any design alterations of the product should not be made. Any design alterations or additions will void the manufacturer's warranty and will further relieve the manufacture of responsibility for personal injury or property damage resulting therefrom.
3. Many electrical and mechanical parts in the products have special safety-related characteristics. These characteristics are often not evident from visual inspection nor can the protection afforded by them necessarily be obtained by using replacement components rated for higher voltage, wattage, etc. Replacement parts which have these special safety characteristics are identified in the Parts List of Service Manual. Electrical components having such features are identified by shading on the schematics and by ( $\Delta$ ) on the Parts List in the Service Manual. The use of a substitute replacement which does not have the same safety characteristics as the recommended replacement parts shown in the Parts List of Service Manual may create shock, fire, or other hazards.
4. The leads in the products are routed and dressed with ties, clamps, tubings, barriers and the like to be separated from live parts, high temperature parts, moving parts and/or sharp edges for the prevention of electric shock and fire hazard. When service is required, the original lead routing and dress should be observed, and it should be confirmed that they have been returned to normal, after re-assembling.
5. Leakage current check (Electrical shock hazard testing)  
After re-assembling the product, always perform an isolation check on the exposed metal parts of the product (antenna terminals, knobs, metal cabinet, screw heads, headphone jack, control shafts, etc.) to be sure the product is safe to operate without danger of electrical shock.  
Do not use a line isolation transformer during this check.

- Plug the AC line cord directly into the AC outlet. Using a "Leakage Current Tester", measure the leakage current from each exposed metal parts of the cabinet, particularly any exposed metal part having a return path to the chassis, to a known good earth ground. Any leakage current must not exceed 0.5mA AC (r.m.s.).
- Alternate check method  
Plug the AC line cord directly into the AC outlet. Use an AC voltmeter having, 1,000 ohms per volt or more sensitivity in the following manner. Connect a 1,500 $\Omega$  10 W resistor paralleled by a 0.15  $\mu$ F AC-type capacitor between an exposed metal part and a known good earth ground.  
Measure the AC voltage across the resistor with the AC voltmeter.  
Move the resistor connection to each exposed metal part, particularly any exposed metal part having a return path to the chassis, and measure the AC voltage across the resistor.  
Now, reverse the plug in the AC outlet and repeat each measurement. Any voltage measured must not exceed 0.75 V AC (r.m.s.). This corresponds to 0.5 mA AC (r.m.s.).

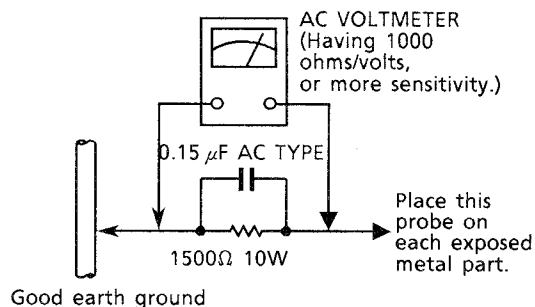

## Warning

1. This equipment has been designed and manufactured to meet international safety standards.
2. It is the legal responsibility of the repairer to ensure that these safety standards are maintained.
3. Repairs must be made in accordance with the relevant safety standards.
4. It is essential that safety critical components are replaced by approved parts.
5. If mains voltage selector is provided, check setting for local voltage.

# Description of ICs

## ■ HD614081SC34 (IC491) : Deck controller

### 1. Terminal Layout

NR.LED	1	64	A.FWD.LED
REV.MODE LED	2	63	A.REV.LED
A.SPEED UP	3	62	B.FWD.LED
B.SPEED UP	4	61	B.REV.LED
MUSIC IN	5	60	REC.LED
B.FWD.REEL.MOTOR	6	59	NR.REC
B.REV.REEL.MOTOR	7	58	BIAS
B.REV.CAM.MOTOR	8	57	NR.OFF
B.FWD.CAM.MOTOR	9	56	REC.MUTE
A.CAM.SW-2	10	55	DCS IN
A.CAM.SW-1	11	54	DCS OUT
A.CAM.SW-0	12	53	GND
A.PULSE IN	13	52	4.19MHZ OSC IN
B.CAM.SW-2	14	51	4.19MHZ OSC IN
B.CAM.SW-1	15	50	TO VCC
B.CAM.SW-0	16	49	RESET IN
B.PULSE IN	17	48	KEY&SW.IN-4
POWER OFF IN	18	47	KEY&SW.IN-3
GND	19	46	KEY&SW.IN-2
A.FWD.REEL.MOTOR	20	45	KEY&SW.IN-1
A.REV.REEL.MOTOR	21	44	KEY OUT-4
A.REV.CAM.MOTOR	22	43	KEY OUT-3
A.FWD.CAM.MOTOR	23	42	KEY OUT-2
CHIP SELECT (EXP/DO)	24	41	KEY OUT-1
PLAY BACK EQ	25	40	SW OUT-2
B.PLAY/PAUSE	26	39	SW.OUT-1
PLAY MUTE	27	38	HI;SPEED DUBBING
CAP.MOTOR ON	28	37	HC
REC	29	36	HM
FADE CTRL.	30	35	HN
BCR	31	34	LC
+5V	32	33	LM

### 2. Key Matrix

	KEY IN 1 (PIN45)	KEY IN 2 (PIN46)	KEY IN3 (PIN47)	KEY IN4 (PIN48)
KEY OUT 1 (PIN41)	—	A◀◀	A▶▶	A▶
KEY OUT 2 (PIN42)	B◀	B◀◀	B▶▶	B▶
KEY OUT 3 (PIN43)	A■	B■	B○	B
KEY OUT 4 (PIN44)	A▶▶B	DOLBY	REV. MODE	CD.REC
SW OUT 1 (PIN39)	A CrO <sub>2</sub>	B CrO <sub>2</sub>	B METAL	—
SW OUT 2 (PIN40)	B PACK	REV REC	FWD REC	A PACK

### 3. Terminal Description

Pin NO.	Symbol	I/O	Function and Operations	Pin NO.	Symbol	I/O	Function and Operations
1	NR.LED	O	NR indicator signal output	33	LM	O	Rec. EQ control signal (Normal speed Metal)
2	REV.MO.LED	O	Reverse mode indicator signal output	34	LC	O	Rec. EQ control signal (Normal speed CrO <sub>2</sub> )
3	A.SPEED UP	O	A deck reel speed control signal output	35	HN	O	Rec. EQ control signal (High speed Normal)
4	B.SPEED UP	O	B deck reel speed control signal output	36	HM	O	Rec. EQ control signal (High speed Metal)
5	MUSIC IN	I	Music scan signal input	37	HC	O	Rec.EQ control signal (High speed CrO <sub>2</sub> )
6	B.FWD REEL	O	B deck forward reel motor control signal	38	HI-SPEED	O	Capstan&EQ control at high speed dubbing
7	B.REV.REEL	O	B deck reverse reel motor control signal	39	SW OUT-1	O	Leaf switch signal output
8	B.REV.CAM	O	B deck reverse cam motor control signal	40	SW-OUT-2	O	Leaf switch signal output
9	B.FWD.CAM	O	B deck forward cam motor control signal	41	KEY OUT-1	O	Key matrix output
10	A.CAM SW-2	O	Cam switch signal from A deck	42	KEY OUT-2	O	Key matrix output
11	A.CAM SW-1	O	Cam switch signal from A deck	43	KEY OUT-3	O	Key matrix output
12	A.CAM SW-0	O	Cam switch signal from A deck	44	KEY OUT-4	O	Key matrix output
13	A.PULSE IN	I	A deck reel pulse input	45	KEY&SW IN-1	I	Key matrix & leaf switch input
14	B.CAM SW-2	O	Cam switch signal from B deck	46	KEY&SW IN-2	I	Key matrix & leaf switch input
15	B.CAM SW-1	O	Cam switch signal from B deck	47	KEY&SW IN-3	I	Key matrix & leaf switch input
16	B.CAM SW-0	O	Cam switch signal from B deck	48	KEY&SW IN-4	I	Key matrix & leaf switch input
17	B PULSE IN	I	B deck reel pulse input	49	RESET IN	I	Reset signal input
18	POWER OFF IN	I	Power off signal input	50	TO VCC	--	PULL UP (+5V)
19	GND	--	Ground	51	OSC	I	Clock oscillation input (4.19MHz)
20	A.FWD.REEL	O	A deck forward reel motor control signal	52	OSC	O	Clock oscillation output (4.19MHz)
21	A.REV.REEL	O	A deck reverse reel motor control signal	53	GND	--	Ground
22	A.REV.CAM	O	A deck reverse cam control signal	54	DSC OUT	O	Compulink signal output
23	A.FWD.CAM	O	A deck forward cam control signal	55	DCS IN	I	Compulink signal input
24	CHIP SELECT	--	Connected to +5V	56	REC.MUTE	O	Recording mute control signal
25	PLAYBACK EQ	O	Playback equalizer control signal	57	NR.OFF	O	NR on/off control signal
26	B.PLAY/PAUSE	O	Deck switching signal	58	BIAS	O	Bias on/off control signal
27	PLAY MUTE	O	Deck out mute signal	59	NR.REC	O	NR rec/play control signal
28	CAP.MOTOR	O	Capstan motor on/off control signal	60	REC.LED	O	Recording indicator output
29	REC	O	Recording control signal	61	B.REV.LED	O	B deck reverse LED indicator output
30	FADE CTRL.	--	Not used	62	B.FWD.LED	O	B deck forward LED indicator output
31	BCR	O	Bias current control signal	63	A.REV.LED	O	A deck reverse LED indicator output
32	+5V	--	Power supply voltage (+5V)	64	A.FWD.LED	O	A deck forward LED indicator output

## ■ MN171202JPA (IC901) : FL & System controller

VDD	1	64	OSC 1
S1	2	63	OSC 2
S2	3	62	VSS
S3	4	61	X2
S4	5	60	X1
S5	6	59	K13
S6	7	58	K12
S7	8	57	K11
S8	9	56	K10
S9	10	55	ACO
S10	11	54	SPK
S11	12	53	STBY IND
S12	13	52	G
S13	14	51	D.RST
S14	15	50	S.MUTE
CSRP IND	16	49	D.INH
VOL IND	17	48	DCS.OUT
VPP	18	47	DCS.IN
VOL UP	19	46	INH
VOL DOWN	20	45	RM.IN
NC	21	44	PRT.IN
1G	22	43	RST
2G	23	42	S.OUT
3G	24	41	S.IN
4G	25	40	S.CK
5G	26	39	CS
6G	27	38	S.OUT
7G	28	37	STB
8G	29	36	SCK
9G	30	35	RCK
SCK	31	34	BP-A
SDA	32	33	BP-B

No.	Symbol	I/O	Functions	No.	Symbol	I/O	Functions
1	VDD	-	Power supply(+ 5V)	42	S.OUT	O	Data signal output for IC932
2~15	S1~S14	O	FL segment control	43	RST	I	Reset signal input
16	CSRP IND	O	CSRP INDICATOR CONTROL	44	PRT.IN	I	Detection signal input for protector
17	VOL IND	O	Volume indicator control	45	RM.IN	I	Remote control signal input
18	vpp	O	Power supply for FL display	46	INH	I	Inhibit signal
19	VOL UP	O	Volume control signal output	47	DCS IN	I	Compu-link signal input
20	VOL DOWN	O	Volume control signal output	48	DCS OUT	O	Compu-link signal output
21	NC	-	Non connection	49	D.INH	O	Power ON/OFF control signal
22~30	1G~9G	O	FL grid control	50	S.MUTE	O	Mute signal
31	SCK	O	Serial clock output	51	D.RST	O	Reset signal output for IC491
32	SDA	O	Serial data output	52	G	O	Output signal for shift resistor
33	BP-B	O	Control signal output for IC931	53	STBY IND	I	Standby indicator signal
34	BP-A	O	Control signal output for IC931	54	SPK	O	Speaker relays ON/OFF control signal
35	RCK	O	Read clock signal output for IC931	55	ACO	O	Power ON/OFF control signal
36	SCK(CLK)	O	Clock signal output for IC601	55~96	KI0~KI3	I	Key matrix input
37	STB	O	Strobe signal output for IC601	60	X1	-	Connected to ground
38	S.OUT	O	Data signal output for IC601	61	X2	-	Non connection
39	CS	O	Chip selector signal output for IC932	62	Vss	-	Connected to ground
40	S.CK	O	Clock signal output for IC921	63	OSC 2	O	Oscillator output
41	S.IN	I	Data signal input for IC932	64	OSC 1	I	Oscillator input

■ HA12136A (IC351) : Noise Reduction Amplifier

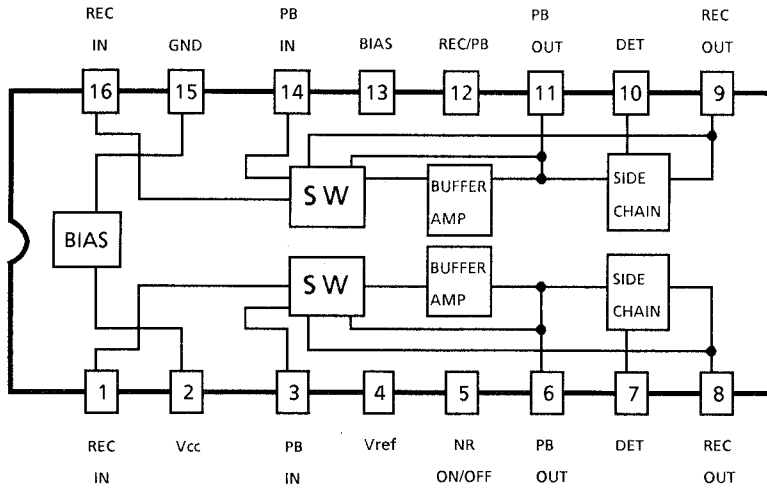

■ BA6218 (IC451,452,453,454) : Reversible motor driver

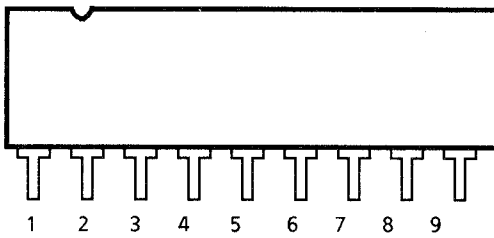

Pin 3(IN)	Pin 1(IN)	Pin 7(OUT)	Pin 9(OUT)
H	L	L	H
L	H	H	L
H	H	L	L
L	L	OPEN	OPEN

■ LB1639-CV (IC503) : Motor Driver

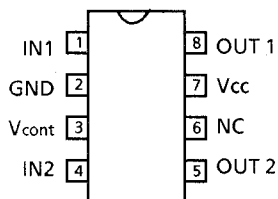

IN 1	IN 2	OUT 1	OUT 2	MOTOR
H	L	H	L	CLOCKWISE
L	H	L	H	COUNTER-CLOCKWISE
H	H	OFF	OFF	WAITING
L	L	OFF	OFF	WAITING

■ TC74HC595AP (IC921) : Shift register

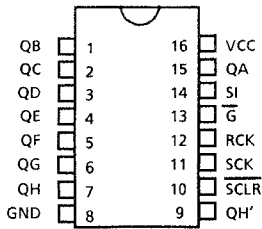

Input					Function
SI	SCK	SCLR	RCK	G	
X	X	X	X	H	Output(QA~QH) disable
X	X	X	X	L	Output(QA~QH) enable
X	X	L	X	X	Shift register is cleared .
L		H	X	X	Shift register in initial stage is "L" .In the other stages, data from the former stage is stored .
H		H	X	X	Shift register in initial stage is "H" .In the other stages, data from the former stage is stored .
X		H	X	X	Shift register does not change.
X	X	X		X	Shift register data is stored in the storage register .
X	X	X		X	Storage register does not change

■ SPS-420-1 (IC922) : Receiver for Remote Controller

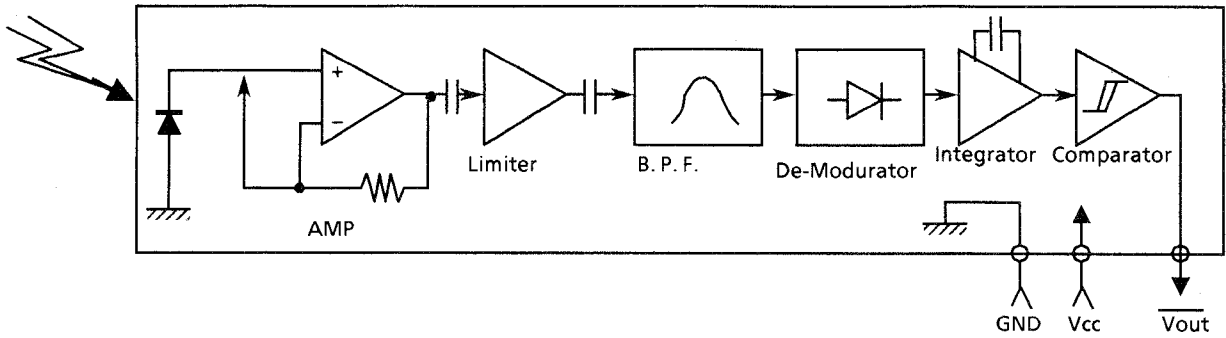

■ XR1091ECP (IC930) : Display Filter

1. Terminal Layout (Top View)

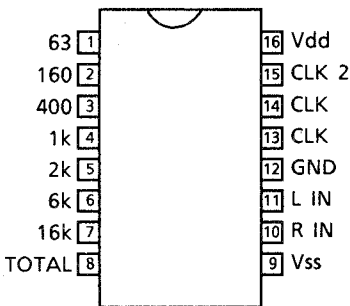

2. Pin Functions

Pin No.	Symbol	Descriptions
1~7	63,160,400,1k,2k,6.3k,16k	Each peak hold output of each frequency's band-pass filter
8	TOTAL	Total frequency output (peak hold)
9	Vss	Power supply (- 6V)
10	R IN	Right channel input
11	L IN	Left channel input : Connecting to ground
12	GND	Ground terminal
13	CLK	Connecting capacitor for clock
14	CLK	Connecting resistor to pin 13 for clock
15	CLK / 2	1/2 clock output
16	Vdd	Power supply (+ 6V)

■ LC7522 (IC641) : Variable Resistor for SEA Control

1. Terminal Layout (Top View)

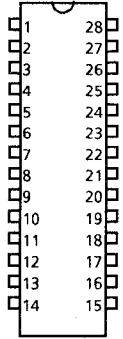

2. Block Diagram

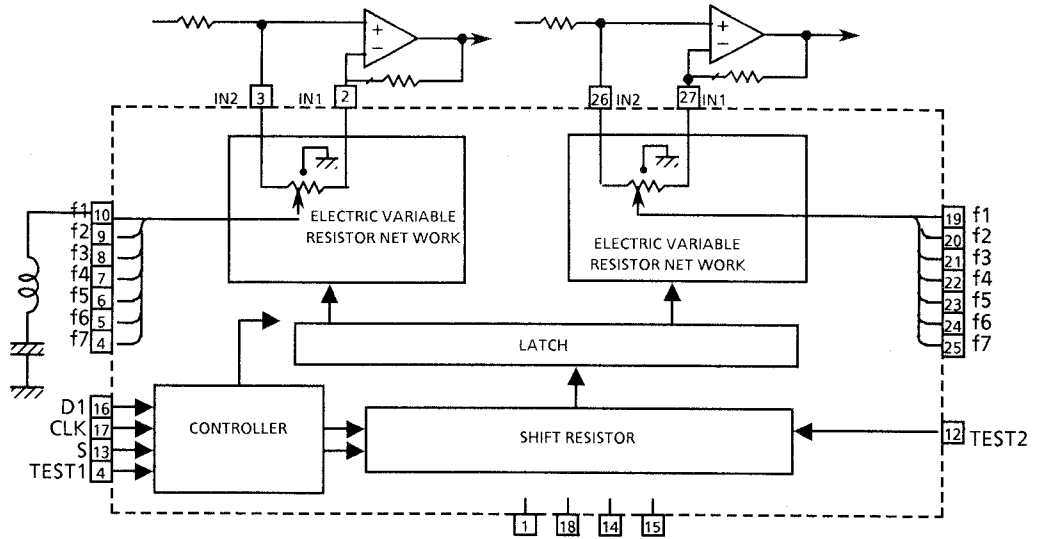

3. Pin Functions

Pin No.	Pin Name	Functions
1	V <sub>DD</sub>	Power supply +7V for audio signal
18	VSS	Ground.
14	VEE	Power supply -7V for audio signal.
15	VCC	Power supply +5V
2,27 3, 26	IN 1 IN 2	Audio signal input The inversion signal of the operational amplifier inputs to IN 1 normally. The non-inversion signal of the operational amplifier inputs to IN 2 normally.
16	SDA	Data input from the CPU. Schmitt inverter type
17	SCK	Clock signal input from the CPU. Schmitt inverter type
4~10 19~25	f1~f7	For connect to band-pass filter. f1~f7x2 (Left and Right)
11	TEST 1	Not use
12	TEST 2	Not use
13	S	Chip Select
28	NC	Not use

■ LA3607S (IC643,644) :S.E.A. Graphic Equalizer

It makes inductive characteristic instead of coil.

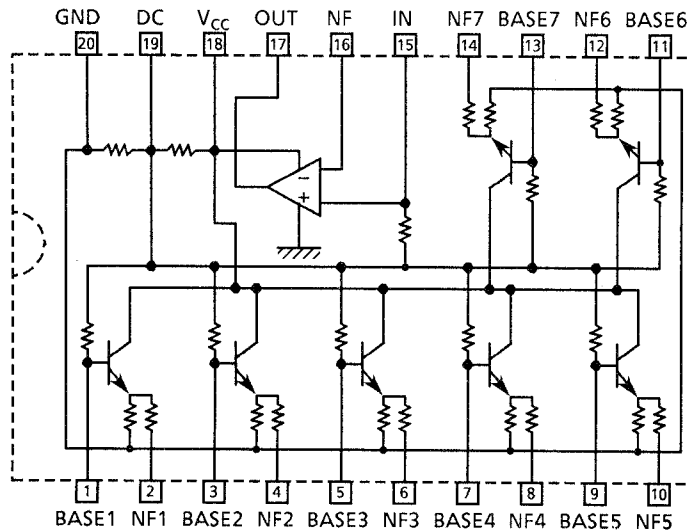

■  $\mu$ PD7001C (IC932) : Analog to Digital Converter

1. Terminal Layout

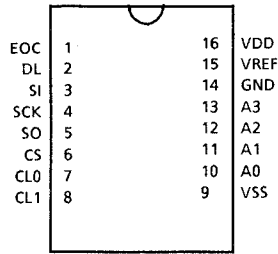

2. Block Diagram

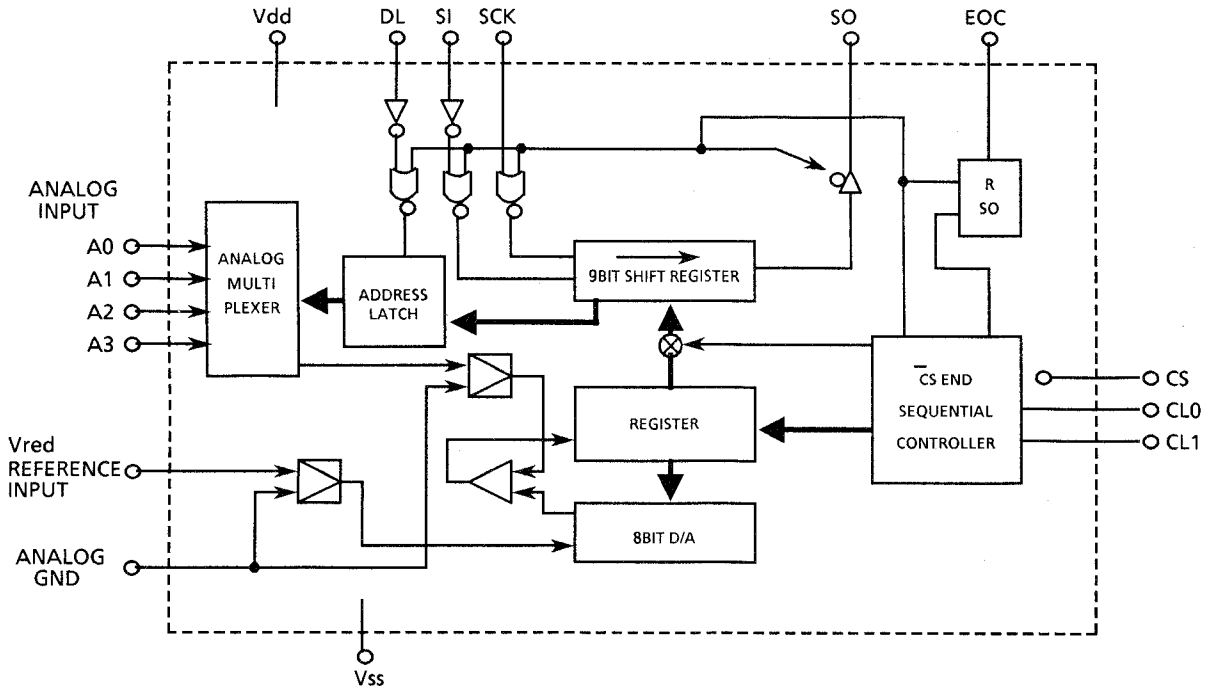

■ TC4052BP (IC931) : Differential 4 channel multiplexer

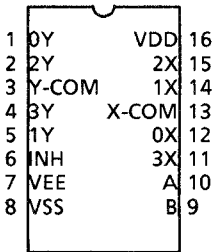

CONTROL INPUT			"ON" CHANNEL
INHIBIT	B	A	
L	L	L	0X,0Y
L	L	H	1X,1Y
L	H	L	2X,2Y
L	H	H	3X,3Y
L	L	L	--
L	L	H	--
L	H	L	--
L	H	H	--
H	Don't care	Don't care	None



# Internal Connections of the FL Display Tube

■ ELU0001 - 092 : FL921

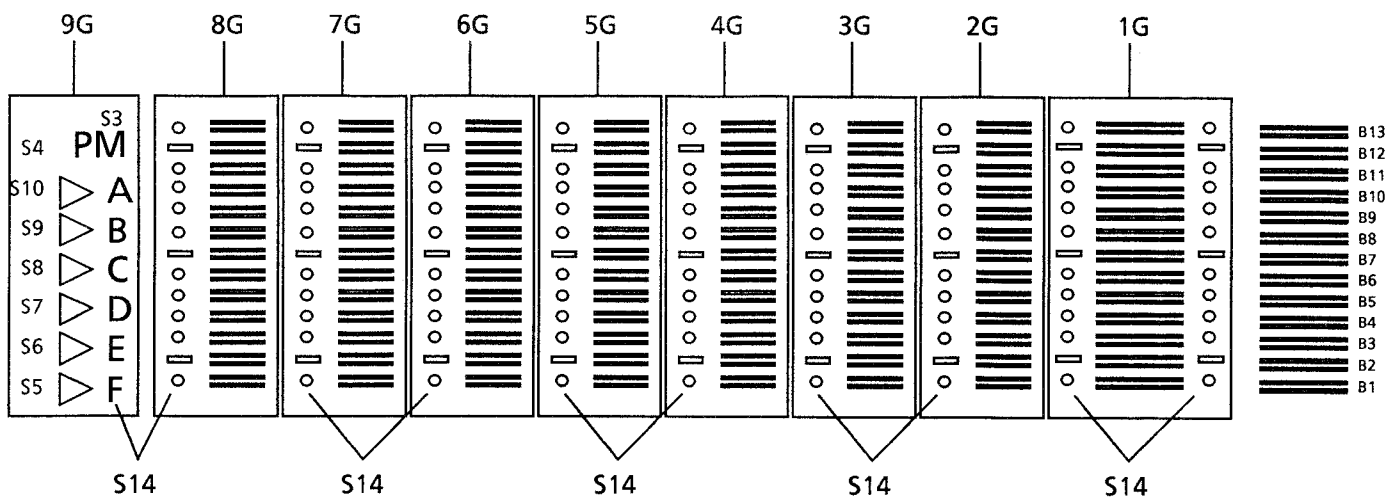

Pin No.	1	2	3	4	5	6	7	8	9	10	11	12	13	14	15	16	17	18	19	20	21	22	23	24	25
Connection	F1	F1	NP	NP	9G	8G	7G	6G	5G	4G	3G	2G	1G	NC	NC	NC	NC	S14	S1	S2	S3	S4	S5	S6	S7

26	27	28	29	30	31	32	33	34	35	36
NC	S8	S9	S10	S11	S12	S13	NP	NP	F2	F2

F : Filament    S : Segment    G : Grid    NP : No Pin    NC : None Connection

	9G	8G	7G	6G	5G	4G	3G	2G	1G
S1	--	B1	B1	B1	B1	B1	B1	B1	B1
S2	--	B2	B2	B2	B2	B2	B2	B2	B2
S3	M (S3)	B3	B3	B3	B3	B3	B3	B3	B3
S4	P (S4)	B4	B4	B4	B4	B4	B4	B4	B4
S5	▶ (S5)	B5	B5	B5	B5	B5	B5	B5	B5
S6	▶ (S6)	B6	B6	B6	B6	B6	B6	B6	B6
S7	▶ (S7)	B7	B7	B7	B7	B7	B7	B7	B7
S8	▶ (S8)	B8	B8	B8	B8	B8	B8	B8	B8
S9	▶ (S9)	B9	B9	B9	B9	B9	B9	B9	B9
S10	▶ (S10)	B10	B10	B10	B10	B10	B10	B10	B10
S11	--	B11	B11	B11	B11	B11	B11	B11	B11
S12	--	B12	B12	B12	B12	B12	B12	B12	B12
S13	--	B13	B13	B13	B13	B13	B13	B13	B13
S14	A B C D E F	● ● ● ● ● ●	● ● ● ● ● ●	● ● ● ● ● ●	● ● ● ● ● ●	● ● ● ● ● ●	● ● ● ● ● ●	● ● ● ● ● ●	● ● ● ● ● ●

# Disassembly Procedures

## 1. Removing the metal Cover

- (1) Remove the 2 screws fastening both sides of the metal cover and the 2 screws fastening the rear side.
- (2) Remove the metal cover.

## 2. Removing the Front Panel assembly

- (1) Remove the metal cover.
- (2) Remove the volume knob and the nut fastening the volume and disconnect the P929.
- (3) Remove the screw (A).
- (4) Cut the Tie Band (C).
- (5) Disconnect the P331, P332, P333, P334 (on ENB-157-6), P321, P972 and the flat wire JB901.
- (6) Release the 3 hooks (B) and remove the front panel assembly from the chassis.

## 3. Removing the Heat sink cover

- (1) Remove the 2 screws (D). (Fig. 5)
- (2) Remove the cover.

## 4. Removing the Rear panel

- (1) Remove the Front Panel assembly.
- (2) Remove the heat sink cover.
- (3) Remove the 12 screws (E). (Fig. 5)

## 5. Removing the Power IC

- (1) Remove the metal cover.
- (2) Remove the rear panel.
- (3) Remove the 3 PC boards (ENJ-063-2, ENJ-063-3, ENJ-063-4) with slow lifting.
- (4) Remove the defective IC.

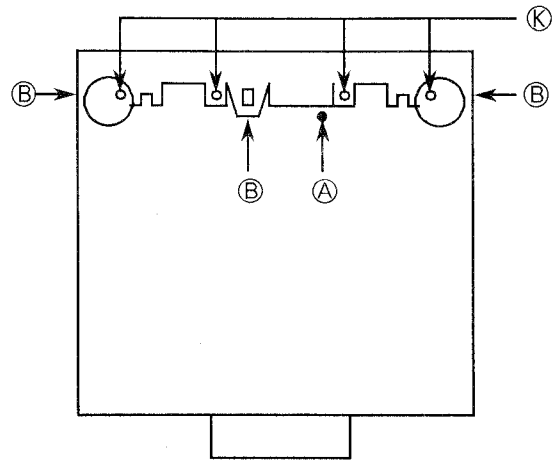

Fig. 1 Bottom view

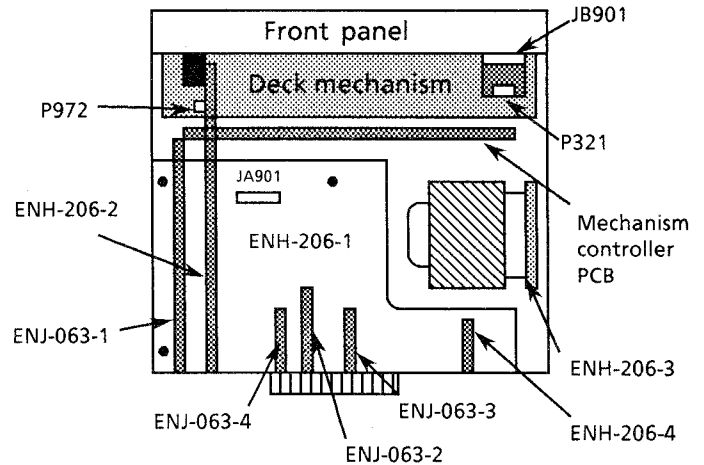

Fig. 2 Top view

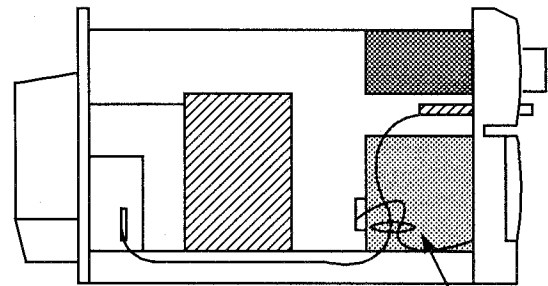

Fig. 3 Side view

Tie band

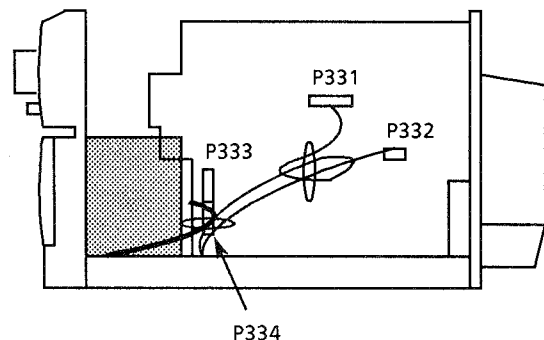

Fig. 4 Side view

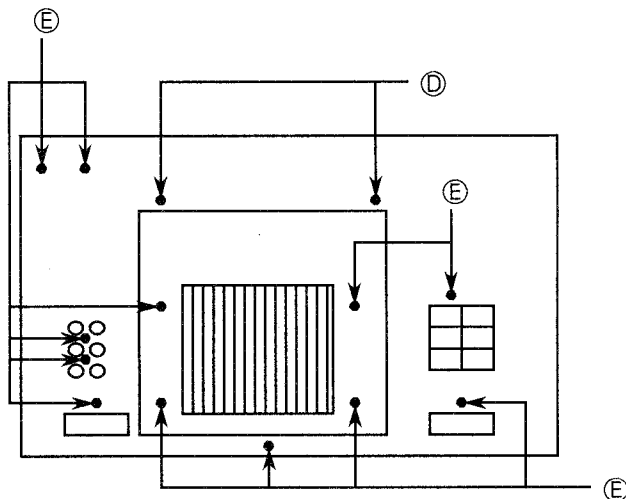
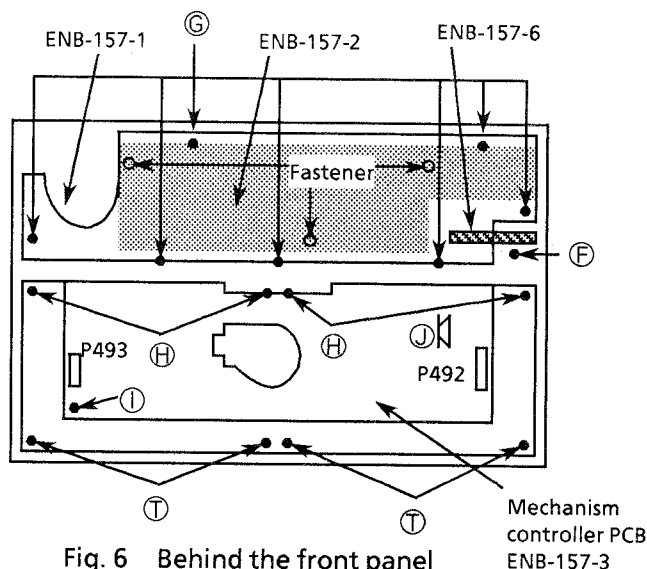

Fig. 5 Rear view

## 6. Removing the Front PC Board assembly (ENB-157-1,ENB-157-2)

- (1) Remove the metal cover.
- (2) Remove the front panel assembly .
- (3) Remove the BALANCE and TWIN BASS knobs.
- (4) Remove the screw ⑥ fastening the headphone PC Board(ENB-157-6) .
- (5) Remove the 7 screws fixing the assembly (Fig. 6).  
The fasteners can release.



## 7. Removing the mechanism assembly

- (1) Remove the metal cover.
- (2) Remove the front panel assembly .
- (3) Disconnect the P492 and P493.
- (4) Remove the 8 blue coloured screws ⑧, ⑨ fixing the mechanism assembly.
- (5) Open the cassette doors and remove the cassette mechanism assembly .

Note : The cassette mechanism is grounded through the bottom plate .  
Therefore, use a jumper between the chassis and the mechanism assembly when operating .  
This mechanism is also designed for pack sensing, then use a cassette tape for checking .

## 8. Removing the Cassette holder

- (1) Remove the cassette mechanism assembly .
- (2) Remove the dampers.
- (3) Remove the holder spring from the holder bracket.
- (4) Remove the cassette holder from the holder bracket.

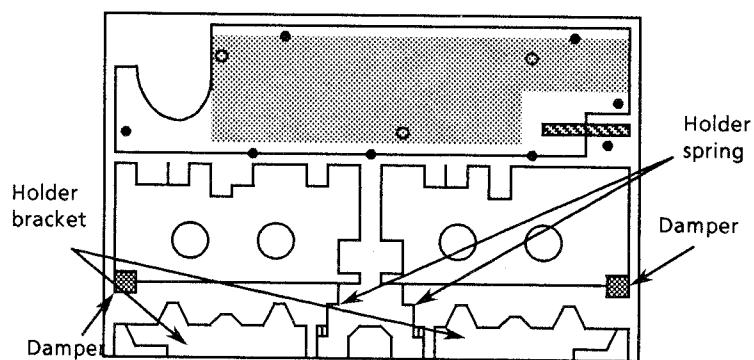

## 9. Removing the Cassette lid

- (1) Open the doors and lift the cassette lids up in the arrow direction .

## 10. Removing the Cassette operation PC Board (ENB-157-4)

- (1) Remove the cassette mechanism assembly .
- (2) Remove the cassette holder
- (3) Remove the 4 screws ⑩ (Fig. 1) and remove the holder brackets .
- (4) Remove the screw fastening the EJECT knob holder .
- (5) Remove the 4 screws fastening the PC Board .

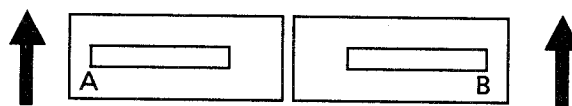

## 11. Removing the Mechanism controller PCBoard (ENB-157-3)

- (1) Remove the front panel assembly.
- (2) Remove the screw ⑪ and release the hook ⑫ .
- (3) Disconnect the flat wires and connectors .

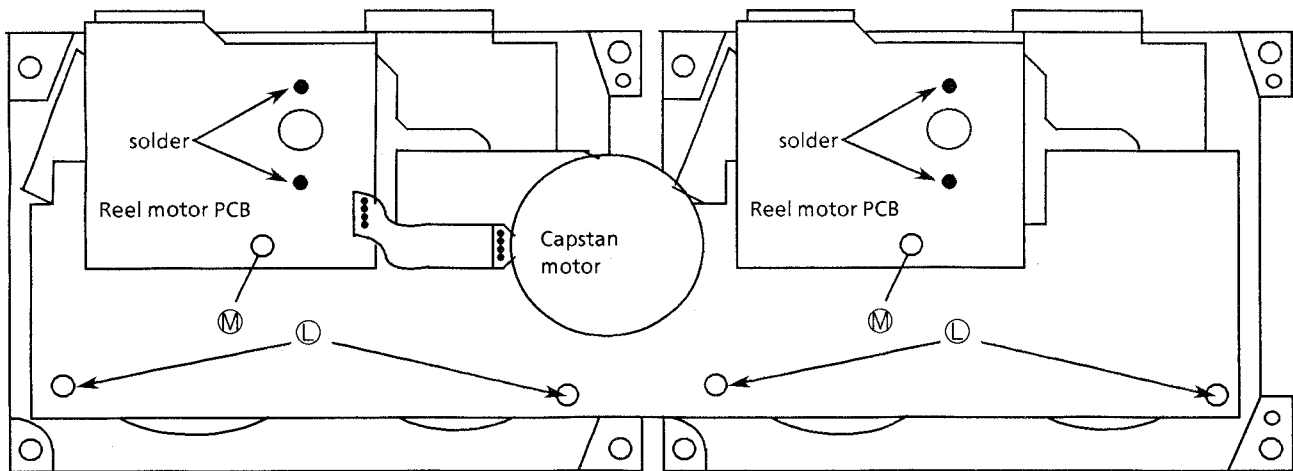

Fig. 9 Rear view of the cassette mechanism

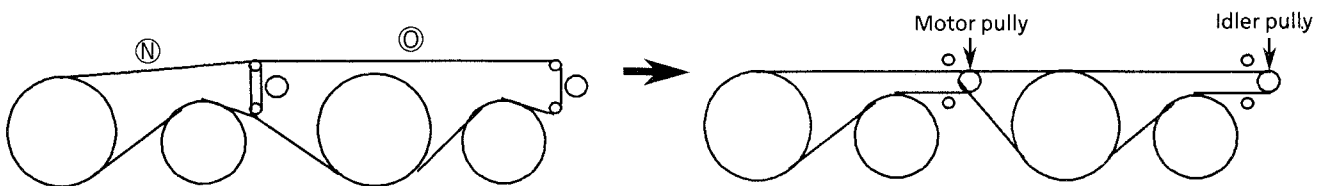

Fig. 10 How to put the belts

## 12. Removing the Reel motor PC Board

- (1) Remove the mechanism assembly.
- (2) Remove the mechanism controller PC Board.
- (3) Remove the screws  $\textcircled{M}$  fixing the reel motor PC Boards (Fig.9).
- (4) Unsolder the reel motor terminals.
- (5) Remove the PC Board.

## 13. Removing the Flywheel

- (1) Remove the mechanism assembly.
- (2) Remove the mechanism controller PC Board.
- (3) Remove the reel motor PC Boards.
- (4) Remove the 4 screws  $\textcircled{L}$  fixing the bracket on which the capstan motor is installed (Fig. 9).
- (5) Remove the bracket and the belts.
- (6) Remove the flywheel .

### Installing

Install the flywheel and the belts to the mechanism as shown in fig. 10. (When putting the belts, put the belt  $\textcircled{N}$  first.)

At last, install the bracket with the capstan motor and put the belts on the pulleys.

## 14. Removing the CAM switch PC Board

- (1) Remove the flywheels.
- (2) Release the hook fixing the cam switch PC Board and remove the PC Board.

- \* When installing the cam switch PC Board, assemble the PC Board so that the part  $\textcircled{P}$  meets part  $\textcircled{Q}$ . Fig. 11

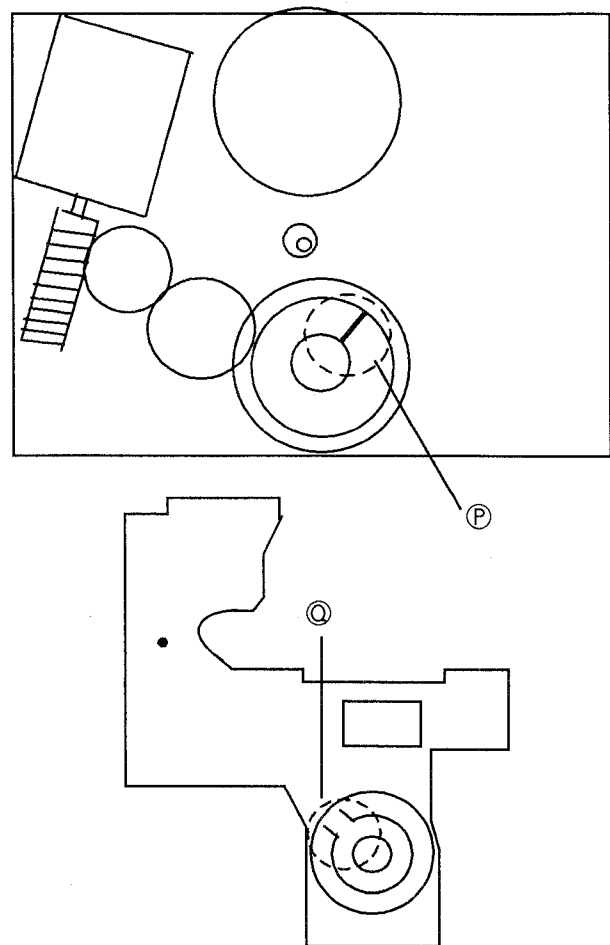

Fig. 11 Gear position

### 15. Removing the Head assembly

- (1) Remove the cassette mechanism assembly.
- (2) Unsolder the flexible wire on the relay PC Board and remove the 2 screws  $\textcircled{S}$  fixing the head assembly (Fig. 13,14).

\* Refer to the Fig.12 when installing .

### 16. Removing the Pinch roller arm assembly

- (1) Release the return springs from the hooks (Fig.14) .
- (2) Remove the hooks fixing the pinch roller arm assembly and remove the pinch roller assembly (Fig. 13).

### 17. Removing the Reel motor

- (1) Remove the mechanism assembly.
- (2) Remove the reel motor PC Board.
- (3) Remove the FR arm assembly (Fig. 14) .
- (4) Remove the screws  $\textcircled{R}$  fixing the motor.
- (5) Release the hooks fixing the motor and remove the motor.

### 18. Removing the Capstan motor

- (1) Remove the mechanism assembly.
- (2) Remove the mechanism controller PC Board.
- (3) Remove the reel motor PC Board.
- (4) Remove the 4 screws  $\textcircled{L}$  fixing the bracket (Fig. 9).
- (5) Release the hooks fixing the bracket and remove the capstan motor with the bracket.
- (6) Remove the 2 screws fixing the motor on the bracket and remove the motor from the bracket.

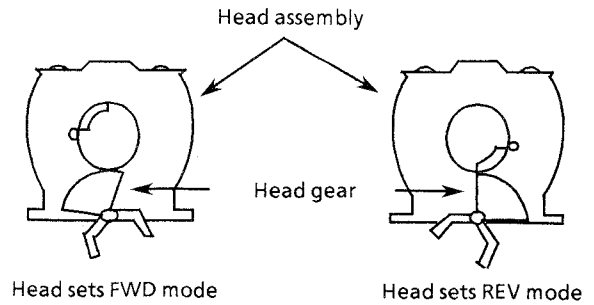

Fig. 12 Bottom view of the head assembly

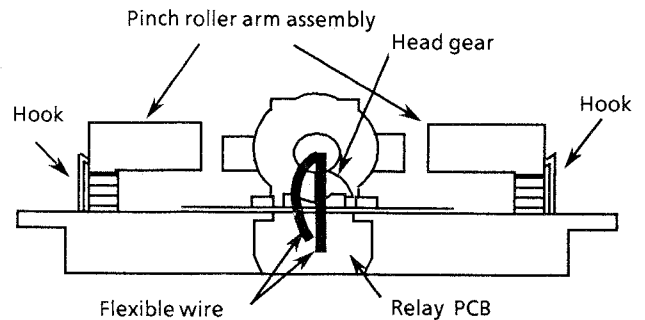

Fig. 13 Bottom view of the cassette mechanism

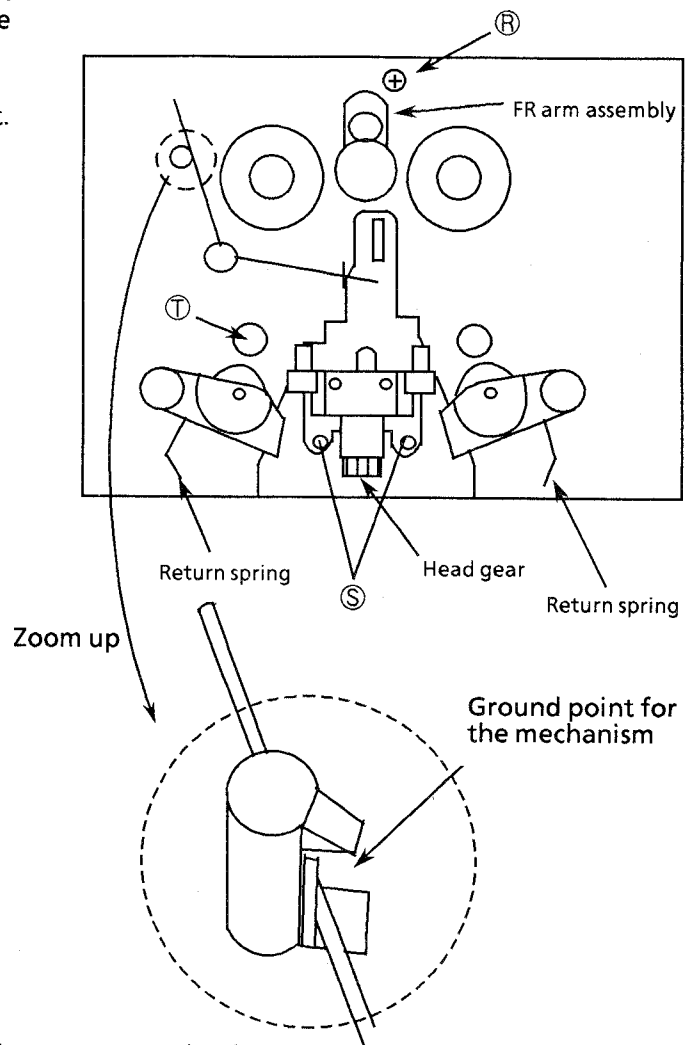

Fig. 14 Front view of the cassette mechanism

# Adjustment Procedures (Cassette Deck)

## 1. Measuring instruments for Adjustment

- |   |   |
|---|---|
| (1) Audio frequency signal generator ( 0dbs output at the 600 ohm output terminal from 50Hz to 20KHz)   | (5) Recording standard tapes<br>AC-513 (CrO <sub>2</sub> ), TMT-7046 (Normal) or equivalent. (Use JVC standard tape )               |
| (2) Attenuator (600 ohm impedance)  | (6) 600-ohm resistor for attenuator matching  |
| (3) Electronic voltmeter  | (7) WOW & FLUTTER meter with frequency counter  |
| (4) STANDARD TAPES<br>VTT-704( head azimuth adjustment)<br>VTT-712 ( tape speed , wow & flutter)<br>VTT-724 (Reference level)<br>VTT-703L(Frequency response) | (8) Distortion meter with band-pass filter<br>(9) Torque gauge : TW-2131,TW-2231<br>(10) C-120 tape (for checking the tape running) |

## 2. Adjustment and repairing the mechanism

(Adjust and inspect the mechanism before adjusting the electronic circuit)

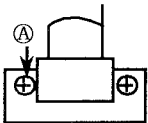
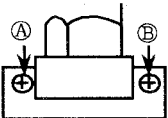
Item	Adjustment method	Standard value	Remarks
Adjusting azimuth of rec/play head	1. Connect an electronic voltmeter to the SPK OUT terminal. (about 1 volt output) 2. Play back VTT-704.		1) When the specified characteristic cannot be obtained because of head wear, cut wire, excessive magnetization, etc., replace the head assembly and adjust the head azimuth. Also, perform the adjustment of the playback level, recording bias current, recording level, etc.  2) When there is the difference of more than 3 ~ 4 dB between left and right output levels, replace the head assembly to avoid complaints.
A mechanism	3. Adjust screw ① so that the indication of the voltmeter becomes maximum when PLAY (▶) is pressed.	Maximum	
	4. After making the adjustment, apply screw lock to prevent screw ① coming loose.		
B mechanism	5. Adjust screw ② so that the indication of the voltmeter becomes maximum when PLAY (▶) is pressed.	Maximum	
	6. Adjust screw ② so that the indication of the voltmeter becomes maximum when PLAY (◀) is pressed.	Maximum	
	7. After making the adjustment, apply screw lock to prevent screws ① and ② coming loose.		
Playback torque	Measure the torque in the playback mode using the torque measurement cassette TW-2131.	26 ~ 62 g-cm	
Fast forward torque	Measure the torque in the fast forward mode by the TW-2231.	80 ~ 200 g-cm	When the standard torque cannot be obtained, replace the FR arm assembly or motor.
Rewind torque	Measure the torque in the rewind mode by the TW-2231.	80 ~ 200 g-cm	When the standard torque cannot be obtained, replace the FR arm assembly or motor.
Wow & flutter	Play back VTT-712 and connect the wow & flutter meter to the SPK OUT terminals, its reading should be within 0.2% (WTD).		As a complaint may occur if the wow & flutter fluctuates by 0.1% even though it is allowed in the standard, repairing is required.

### 3. Electrical Circuit Adjustments

Make the following adjustments after adjusting the head azimuth.

In principle, the adjustments should be made in the following sequence.

Set the NR switch to OFF and the BEAT CUT switch to "1".

Adjustments marked with an asterisk (\*) should always be made after the head is replaced.

Item	Adjustment Method	Adjustment Location	Standard Value	Remarks
Motor speed	1. Play back VTT-712 and connect a frequency counter to the speaker terminals.	Semi-fixed resistor on the main PC Board		Connect a wow & flutter meter with a built-in frequency counter to the speaker terminals.
	2. Normal speed Adjustment 1) Mechanism B Play back deck B and adjust the semi-fixed resistor VR481 on ENB - 157 - 3. 2) Mechanism A Play back deck A and confirm that the value of deck B $\pm 51\text{Hz}$ .	VR481  VR265	3,000 Hz $\pm 10\text{Hz}$	Adjust the normal speed first, and perform the high speed adjustment.
	3. High-speed adjustment 1) Mechanism B Play back deck B and adjust the semi-fixed resistor VR482 on ENB - 157 - 3.	VR482	6,000Hz $\pm 20\text{Hz}$	
* 1 Playback level	Play back VTT-724 (1 kHz) and connect an electronic voltmeter between W513 and E(W514) of DOLBY TP for left, or W515 and E(W514) for right. And then, adjust the semi - fixed resistors.  Play back VTT-703L (10 kHz) and connect an electronic voltmeter between W513 and E(W514) of DOLBY TP for left, or W515 and E(W514) for right. And then, adjust the semi - fixed resistors.	<b>A Deck</b> (1KHz) L: VR451 R: VR452 (10KHz) L: VR455 R: VR456 <b>B Deck</b> (1KHz) L: VR453 R: VR454 (10KHz) L: VR457 R: VR458	400mV  130mV  400mV  130mV	
* 2 Recording bias frequency	Connect a frequency counter between W428(or W430) and W429 of BIAS TP, and perform a recording.	L331	100 kHz $\pm 5$ kHz	Set the BEAT CUT SWITCH to "1" when using a metal tape.
* 3 Recording frequency Response	Record 1 kHz/12.5 kHz with the NR switch off and input 30mV to VCR/ DAT. While playing back these recorded signals, adjust the variation of the 12.5 kHz outputs from the 1kHz output to the standard value using VR331 and VR332. (Basically, adjust so that the 1 kHz and 12.5kHz outputs are flat.)	(L)VR331 (R)VR332	0 $\pm$ 3 dB for 12.5 kHz with 1 kHz as the standard.	1) The recording and playback frequencies of a cassette deck are adjusted by adjusting the bias. This is because the frequency response depends more on the bias current than with an open-reel deck. 2) Perform the adjustment with normal tape and confirm that the values are within the range for metal tape.

Note: After completing the recording level adjustment in item 3, check the recording and play back frequencies with the NR switch on. Fine adjust again if the value is 0  $\pm$  5 dB or more at 1 kHz and 12.5 kHz.

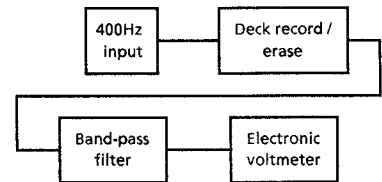
Item	Adjustment Method	Adjustment Location	Standard Value	Remarks
* 4 Recording Level	1) Input a 1 kHz (300mV) to VCR / DAT terminals and record on the left and right channels . 2) Connect an electronic voltmeter between W513 and W514 of DOLBY TP for left, or W515 and W514 for right. And then, adjust the semi;fixed resistors when playing back.	(L) VR311 (R) VR312	400mV	Adjust with normal tape and make sure that the left / right level difference is 1.0dB or less
* 5 Recording/playback distortion	1) Input a 1 kHz (300mV) to VCR / DAT terminals and record it. 2) Play it back and check the speaker output with a distortion meter to make sure it is the rated value.		3% or less	Perform after the bias current and recording level adjustments.
6 Recording/playback S/N ratio	1) Input a 1 kHz (300mV) to VCR / DAT terminals and record it. While recording, remove the input and record without a signal. 2) Play back and use an electronic voltmeter to compare the 0 dB recording output and the out-put of the recording without a signal to make sure this is the rated value.		45 dB or more	
7 Erase ratio check	1) Input a 400 Hz (950mV) to VIDEO / AUX terminals and record it using TMT-7040. 2) Rewind and erase part of the recorded section. 3) Compare the outputs of the recorded and erased sections using an electronic voltmeter.		55 dB or more	Connect a 400 Hz band-pass filter between the deck and electronic Voltmeter . 
8 Auto-stop check	When playing back and recording, make sure to operate AUTO STOP.			



← Mechanism controller PCB (ENB-158-3)

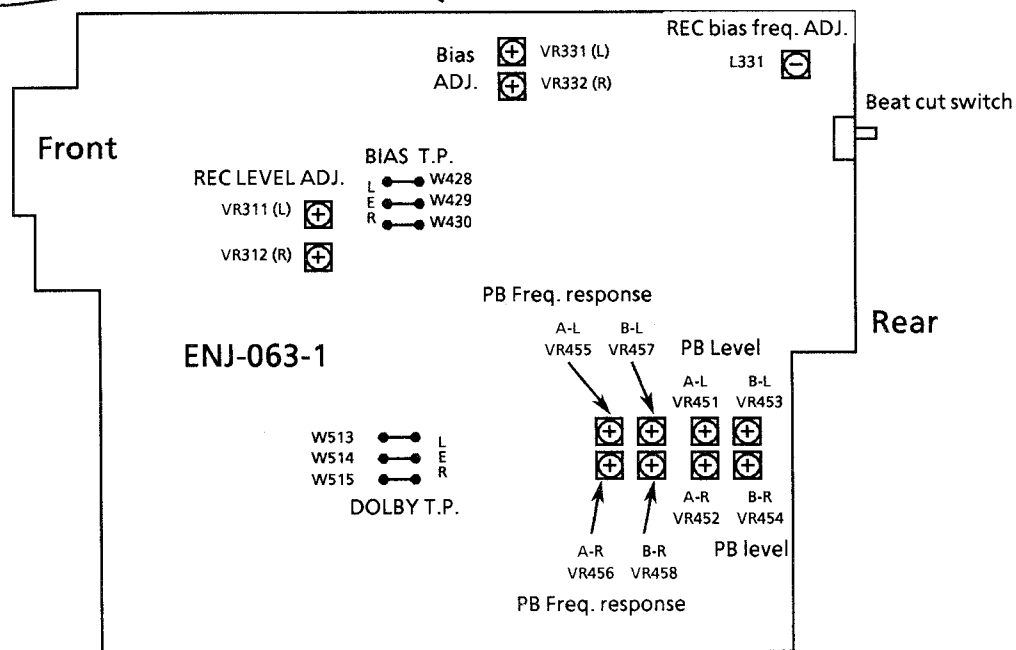





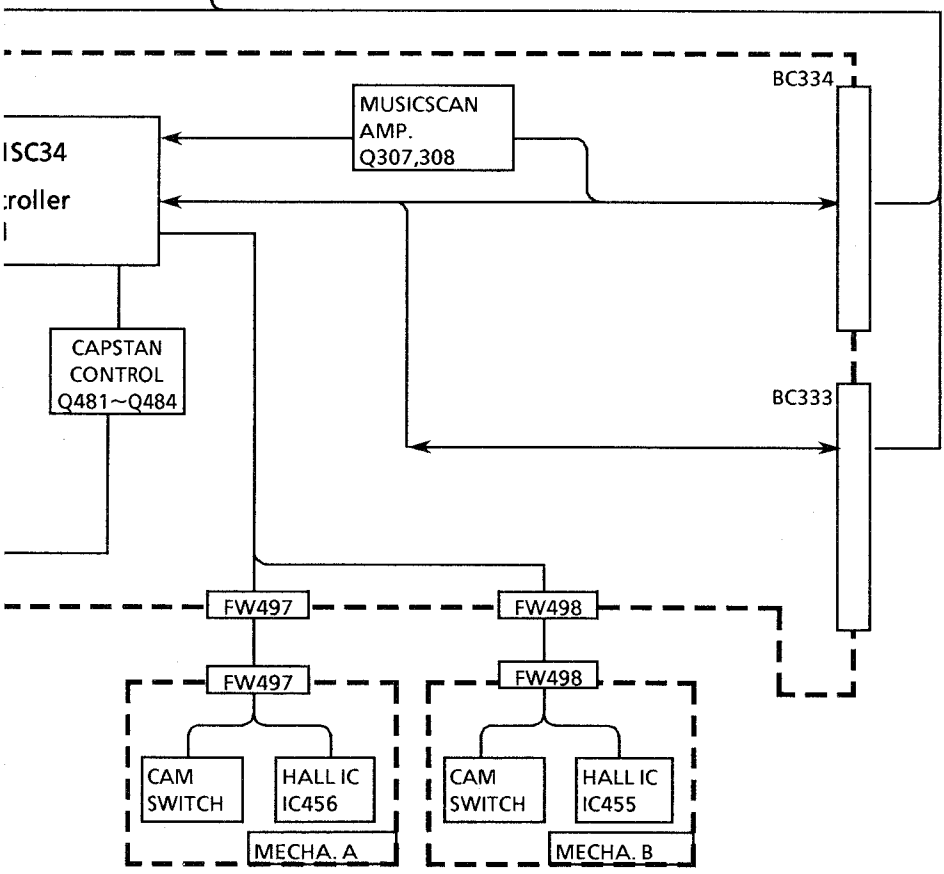
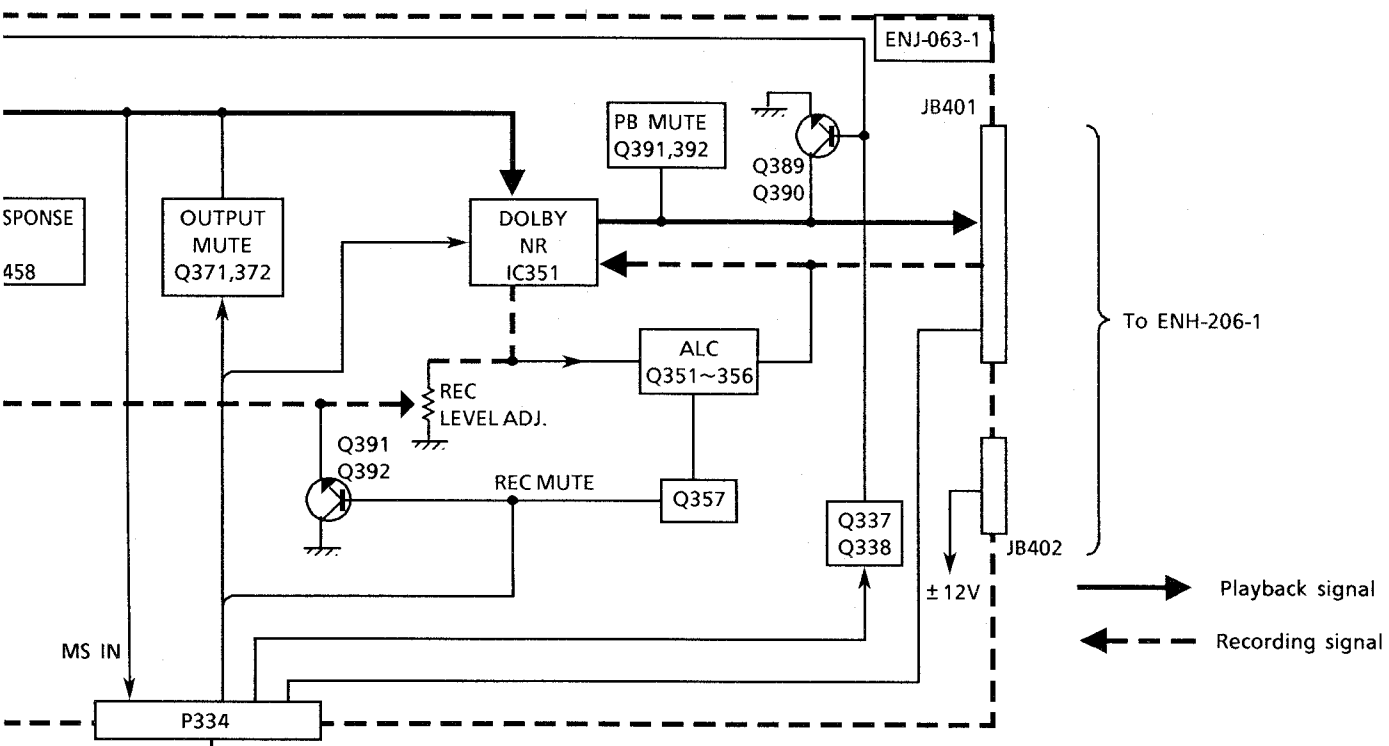

# AUDIO SECTION

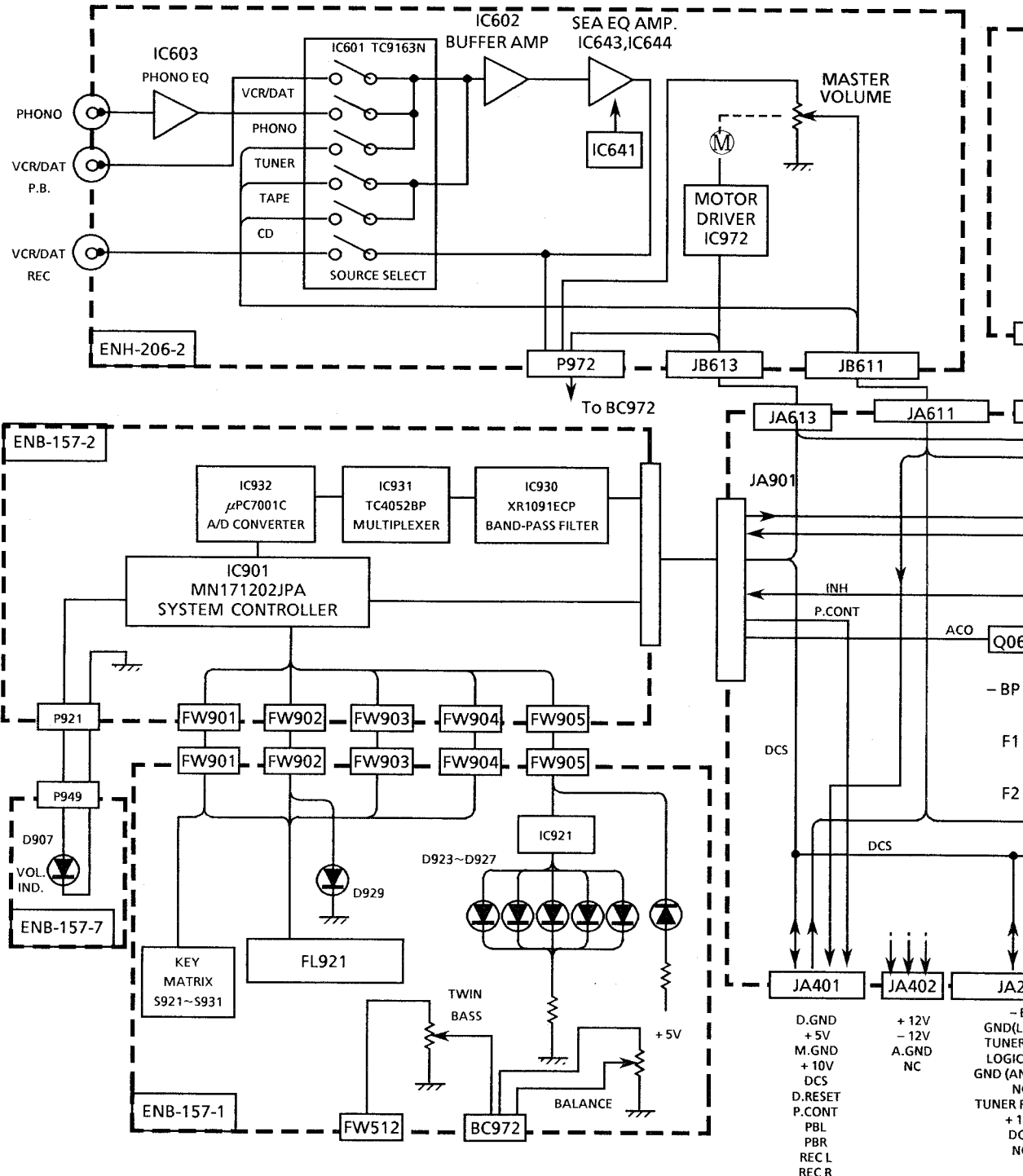

ENJ-063-1 : Deck section

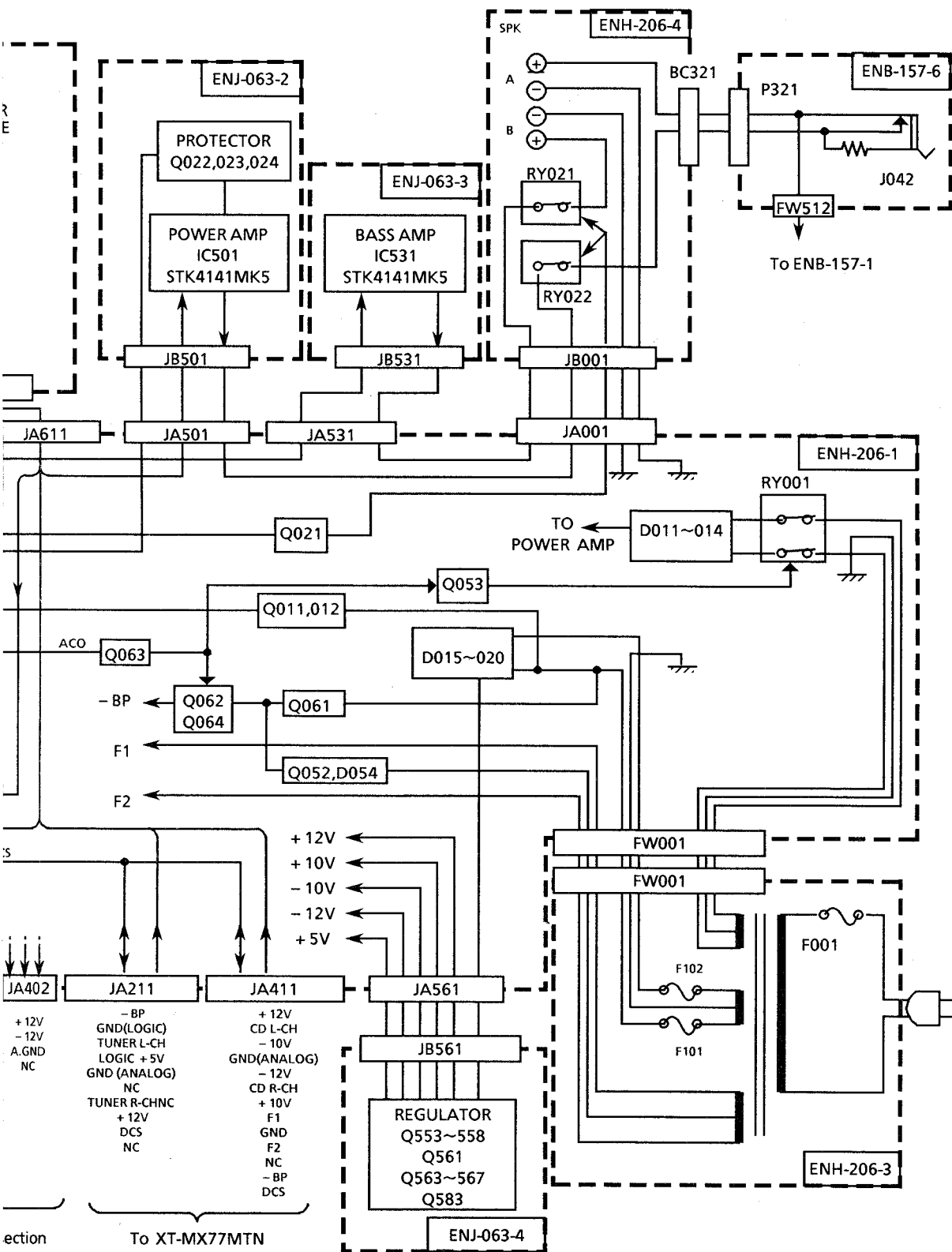

# Schematic Diagram

## ■ Source Selector, Power Supply & Power Amplifier

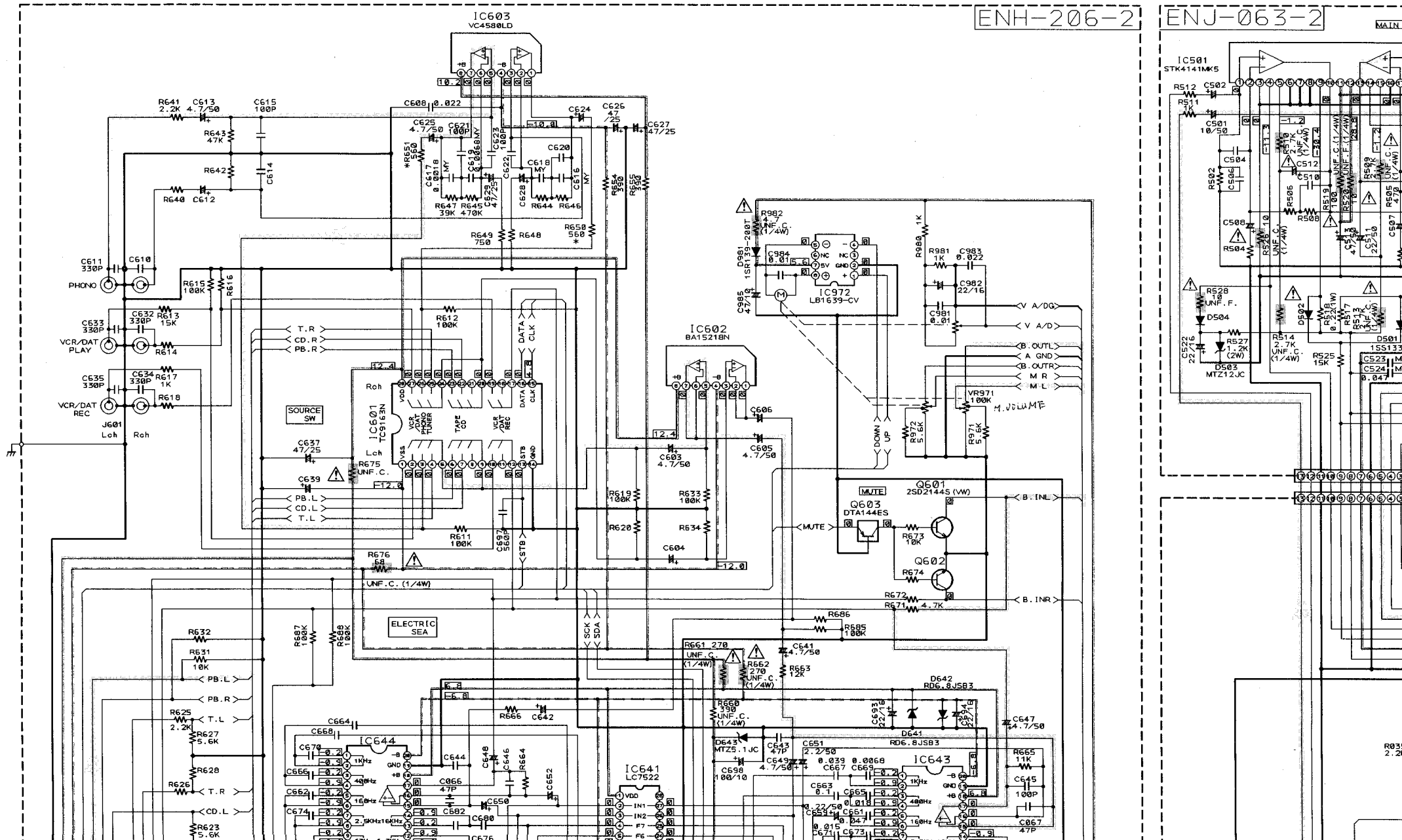

6-2

ENJ-063-2

MAIN POWER AMP

ENJ-063-3

BASS POWER AMP

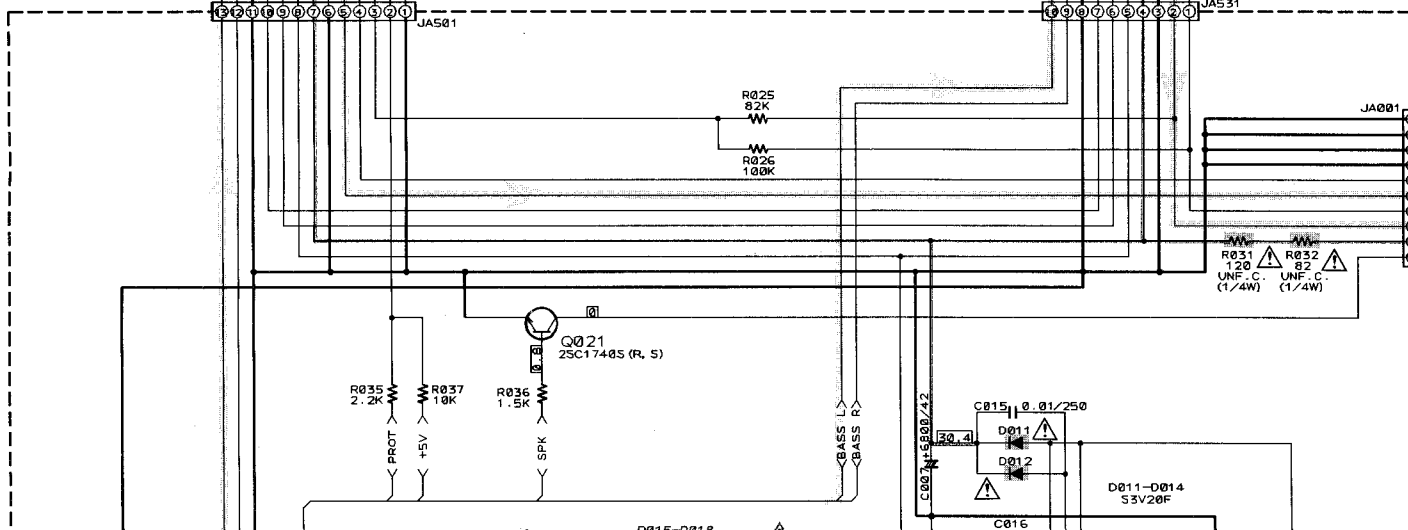
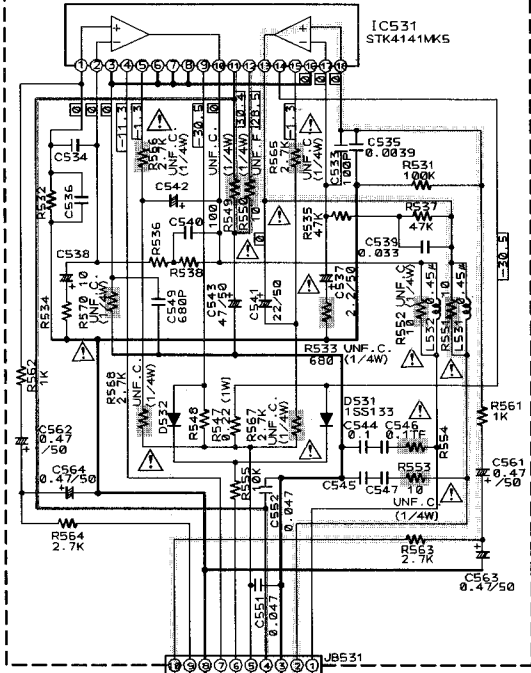
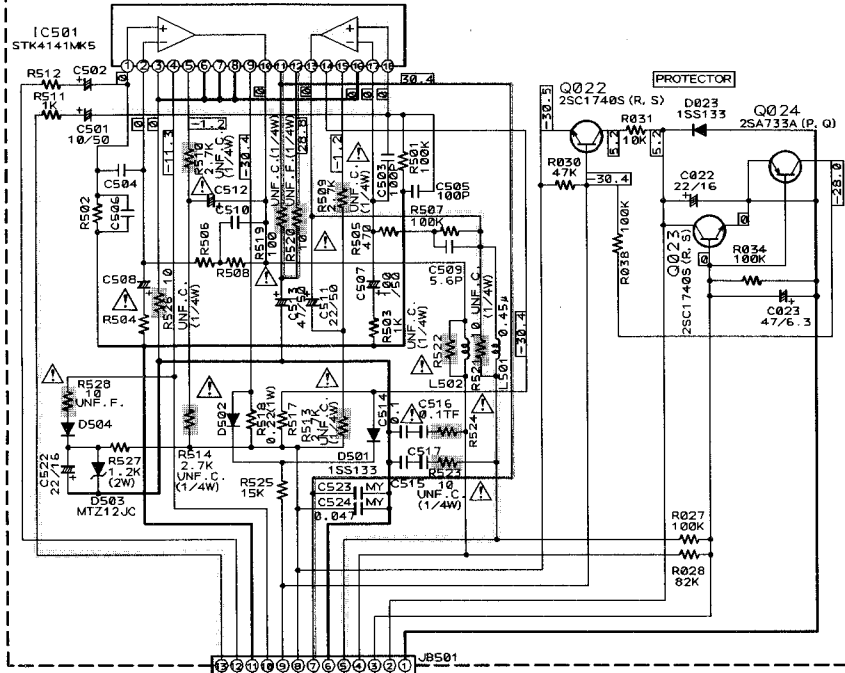

ENH-206-4

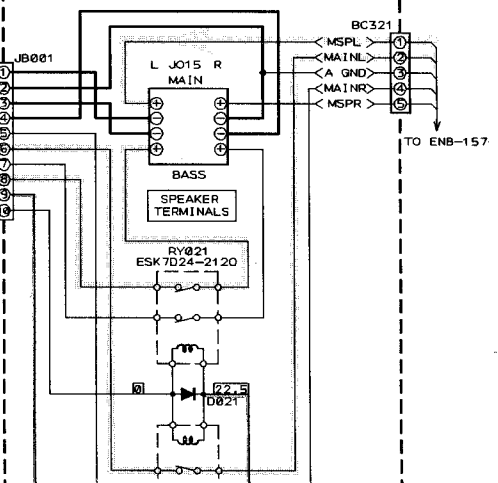

TO ENB-157



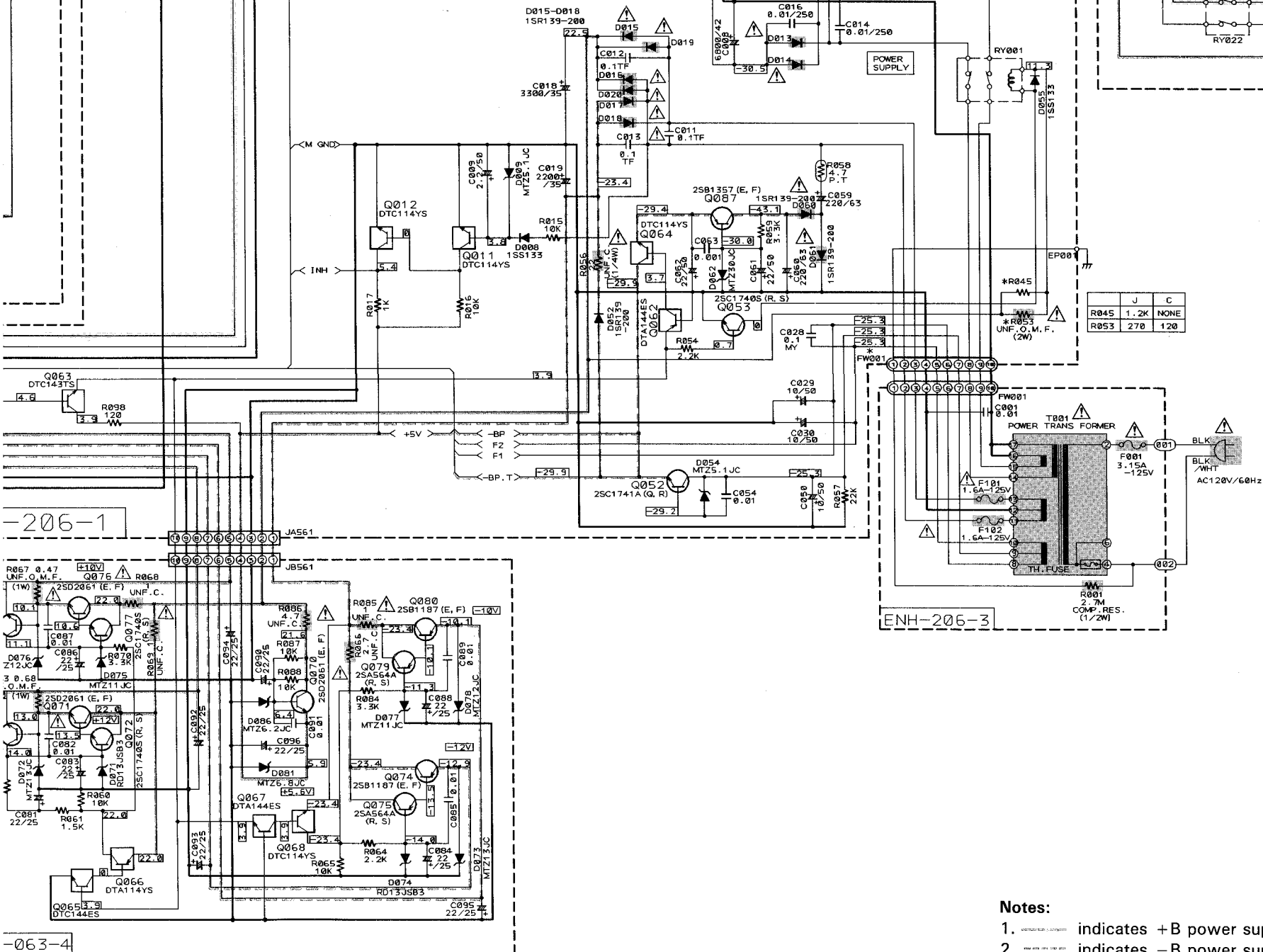

- Notes:**
1. indicates +B power supply.
  2. indicates -B power supply.
  3. indicates main signal path.
  4. When replacing the parts in the shaded are ( ) and those marked with , be sure to use the designated parts to ensure safety.
  5. The design and contents are subject to change without notice.



■ Cassette Control

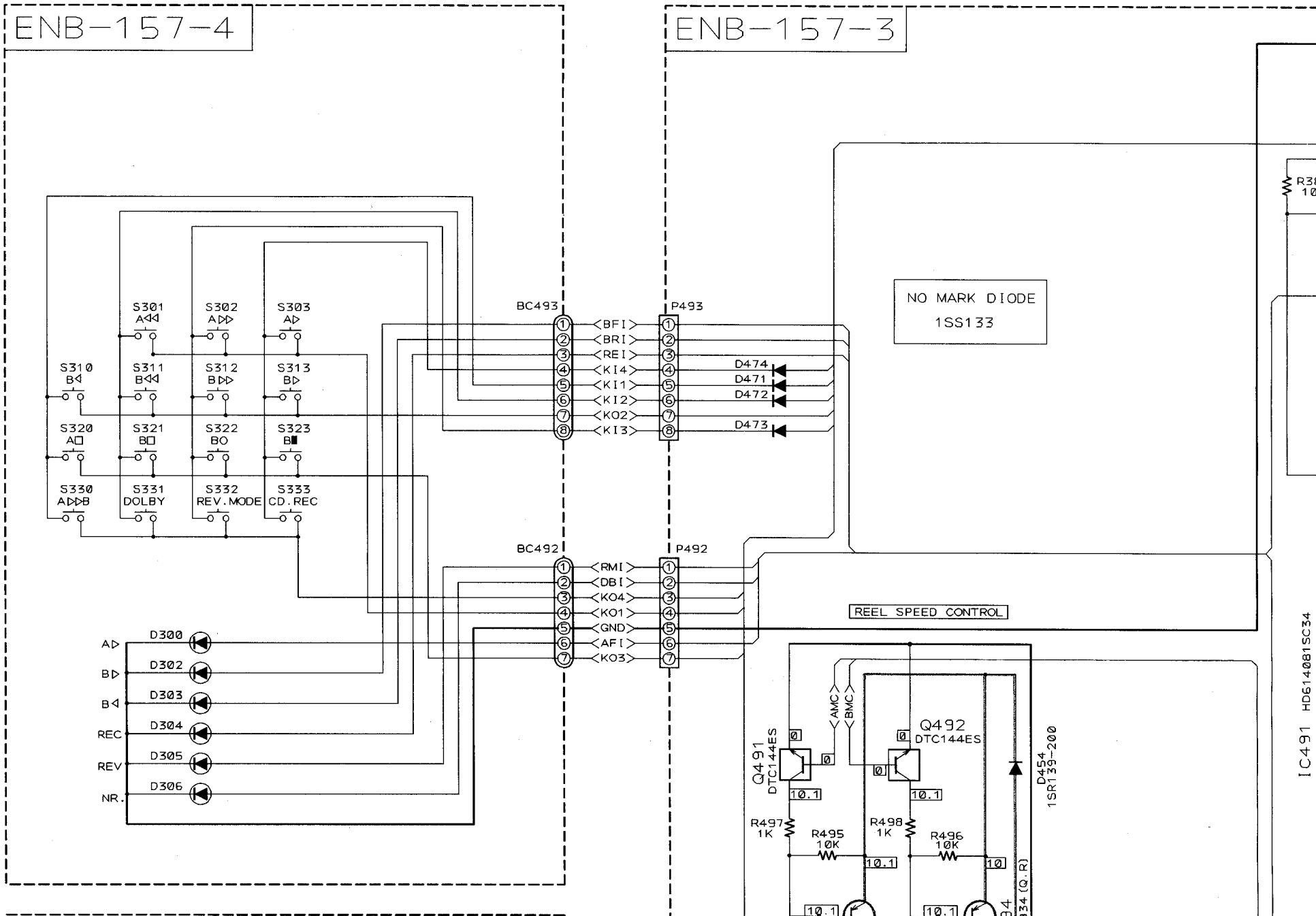

MODE

F

94

D454  
1SR139-200

34 (Q.R)

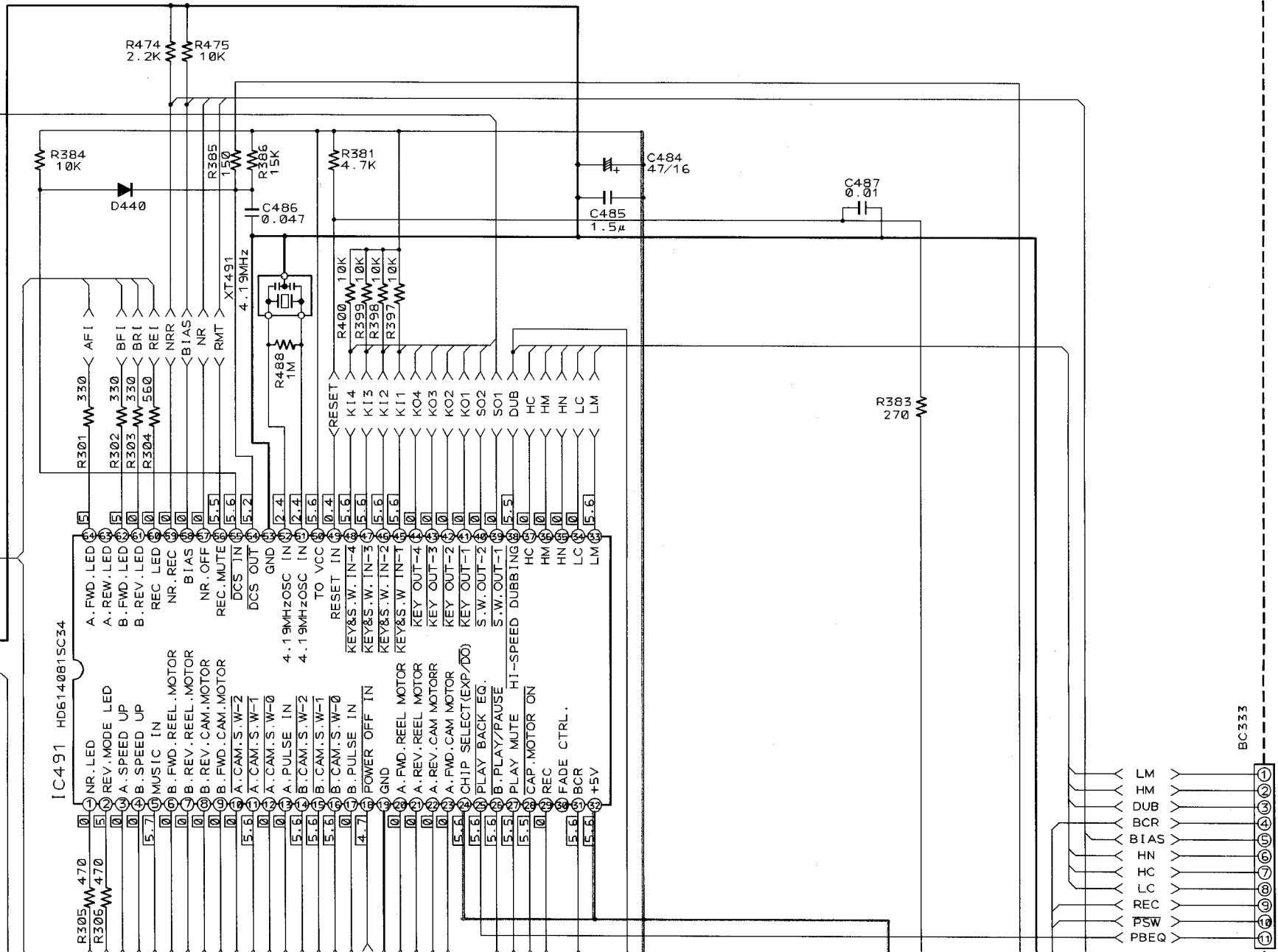

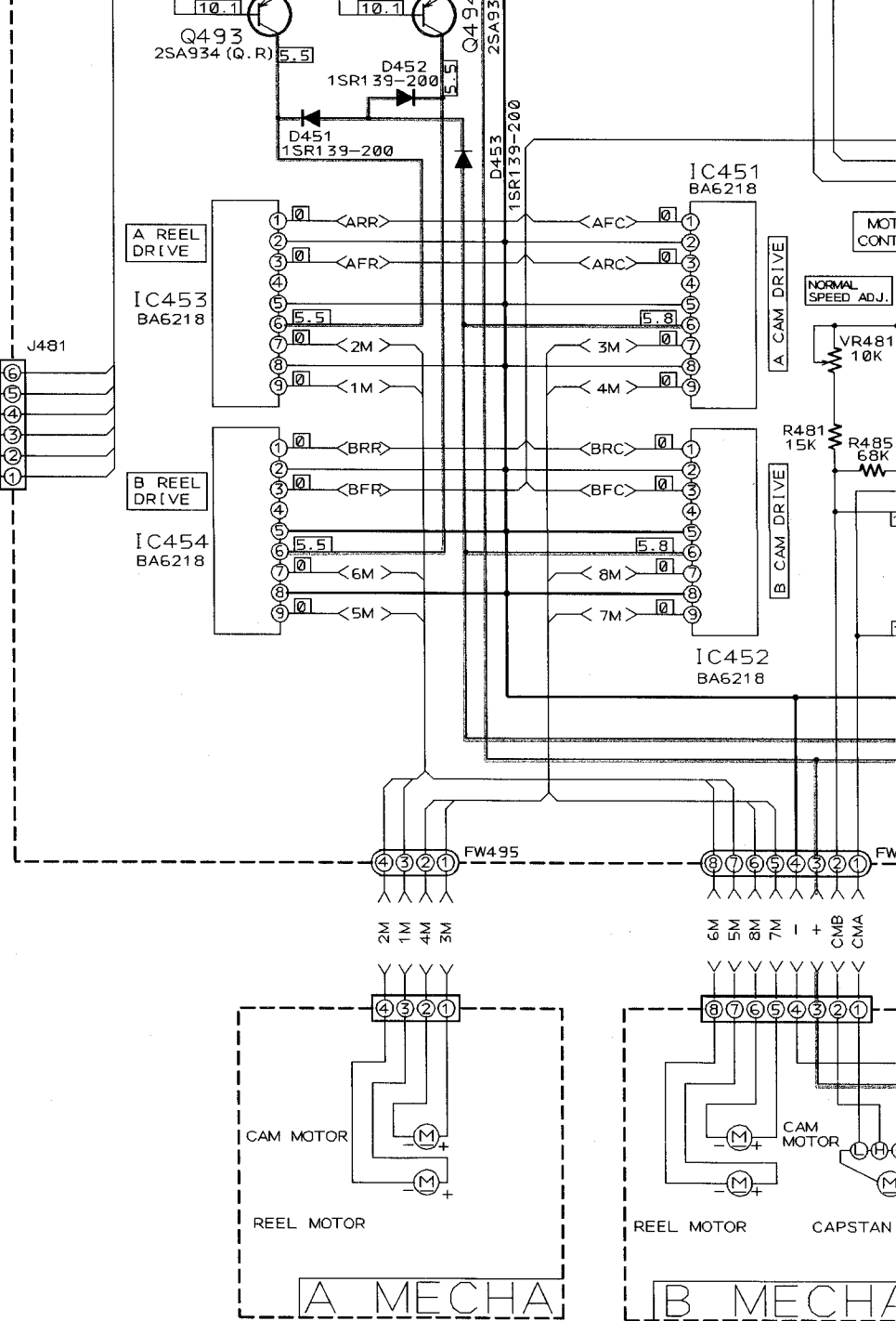
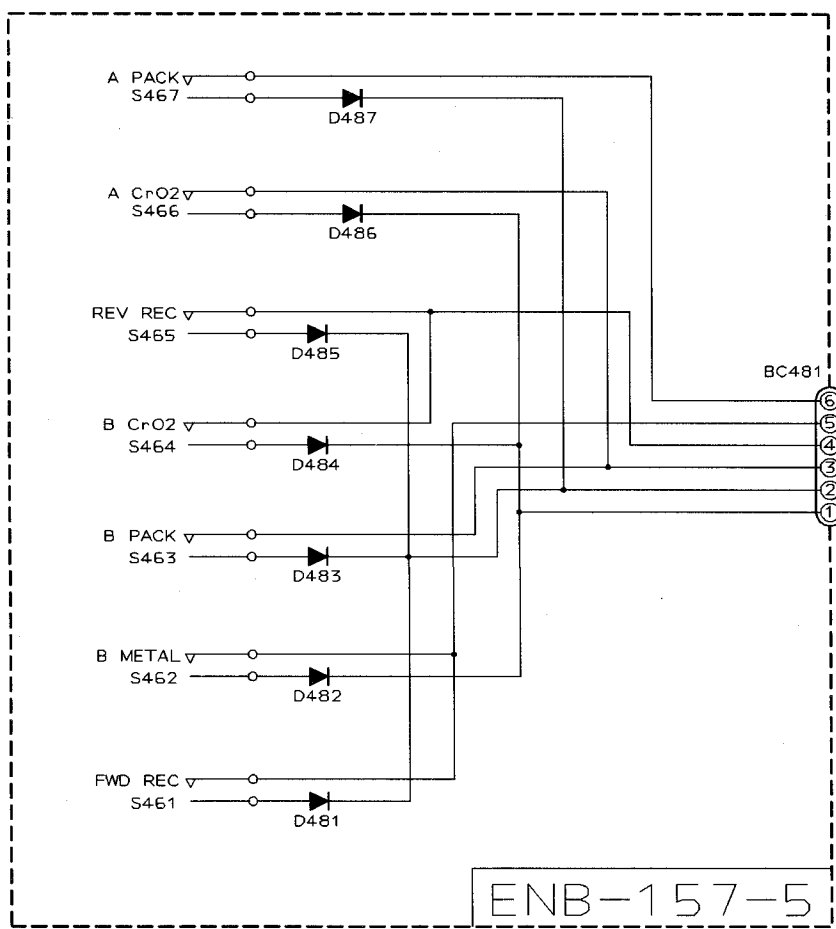

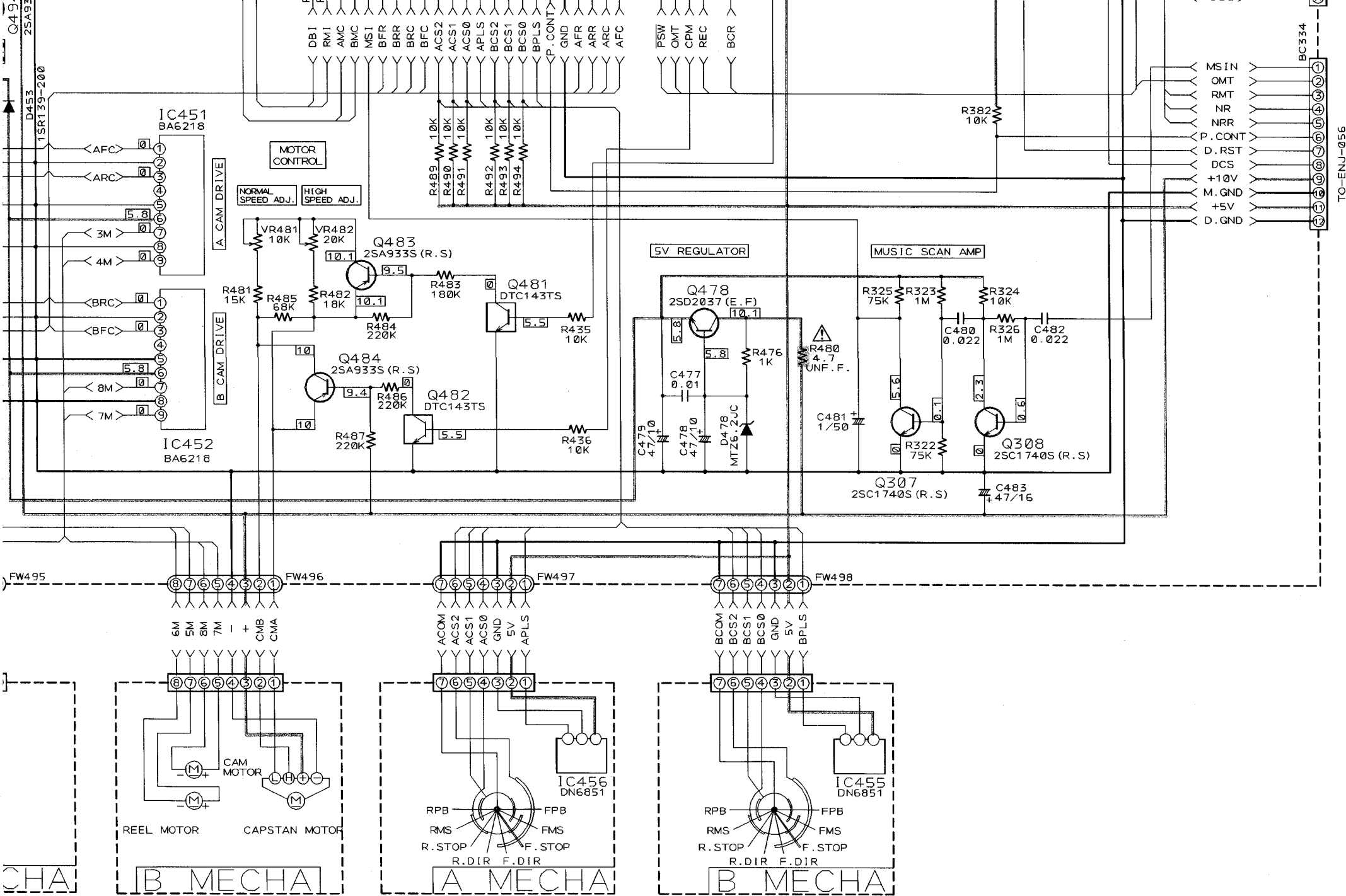

TO-ENJ-056





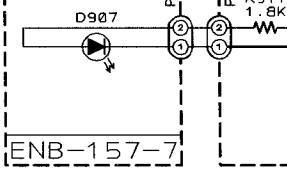

ENB-157-7

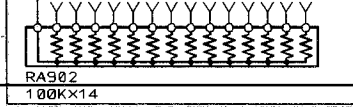

ENB-157-1

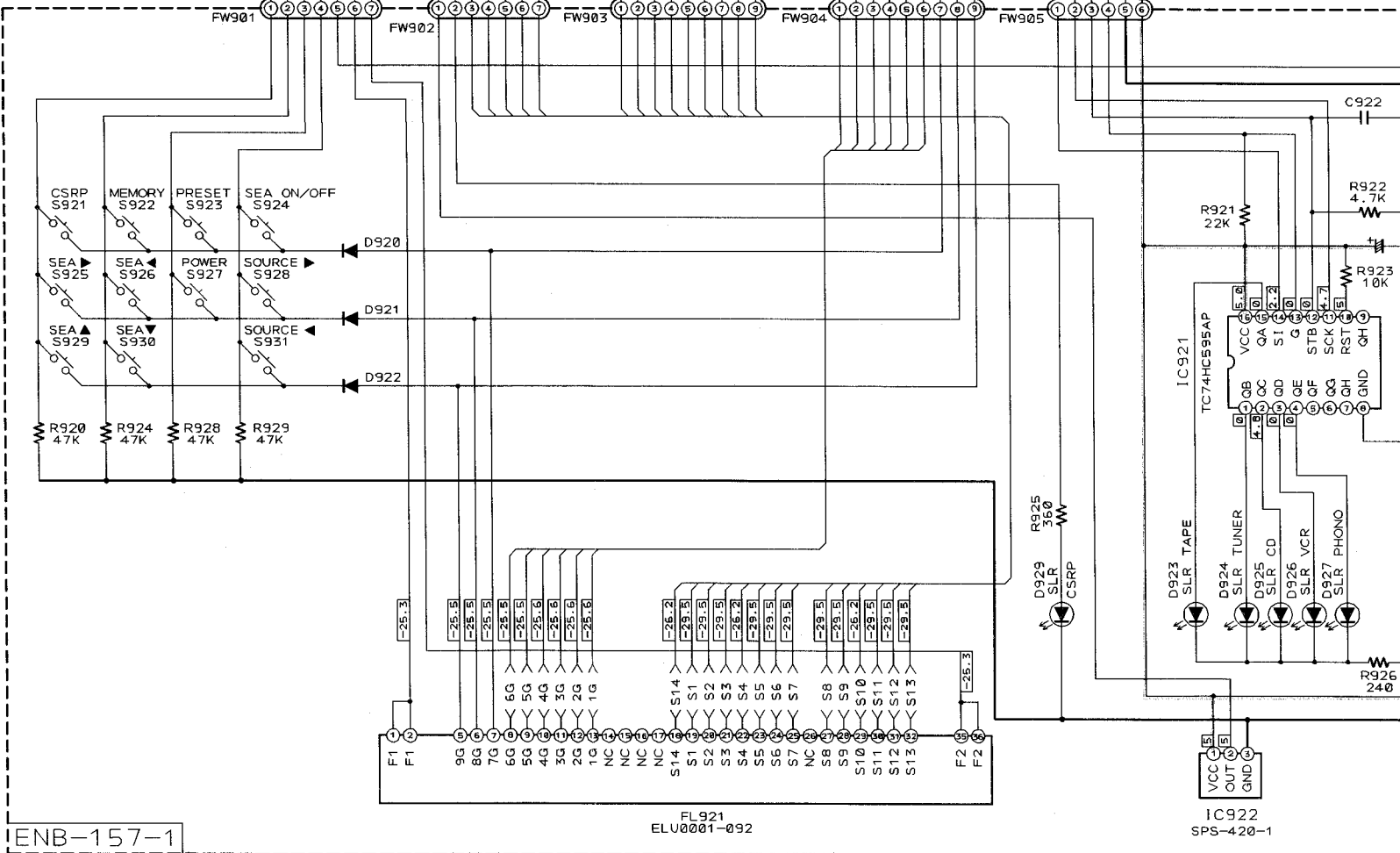



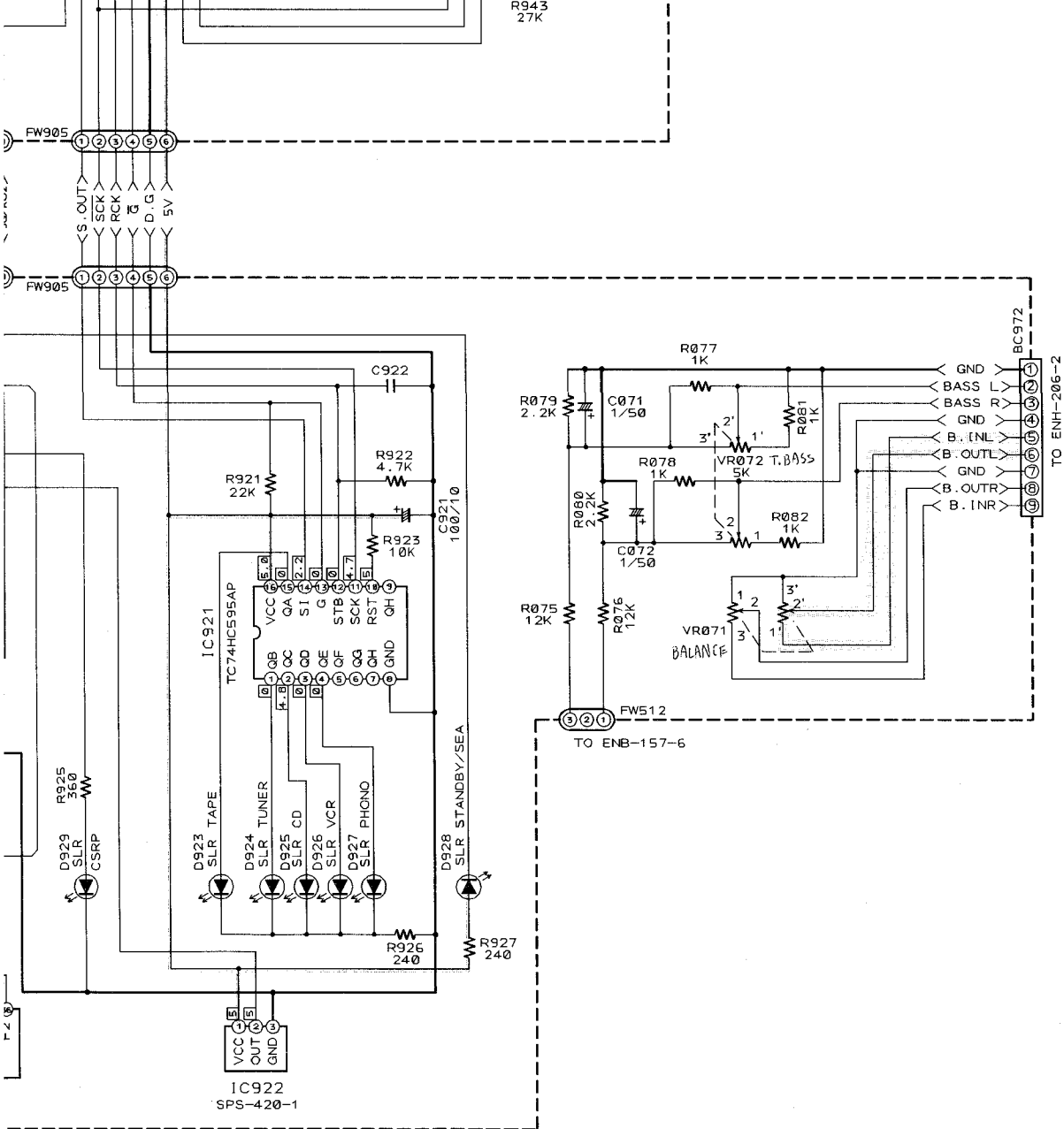

FL921  
ELU0001-092

IC922  
SPS-420-1



**Notes:**

1.  indicates +B power supply.
2.  indicates -B power supply.
3.  indicates main signal path.
4. When replacing the parts in the shaded are (  ) and those marked with  , be sure to use the designated parts to ensure safety.
5. The design and contents are subject to change without notice.



Cassette Amplifier

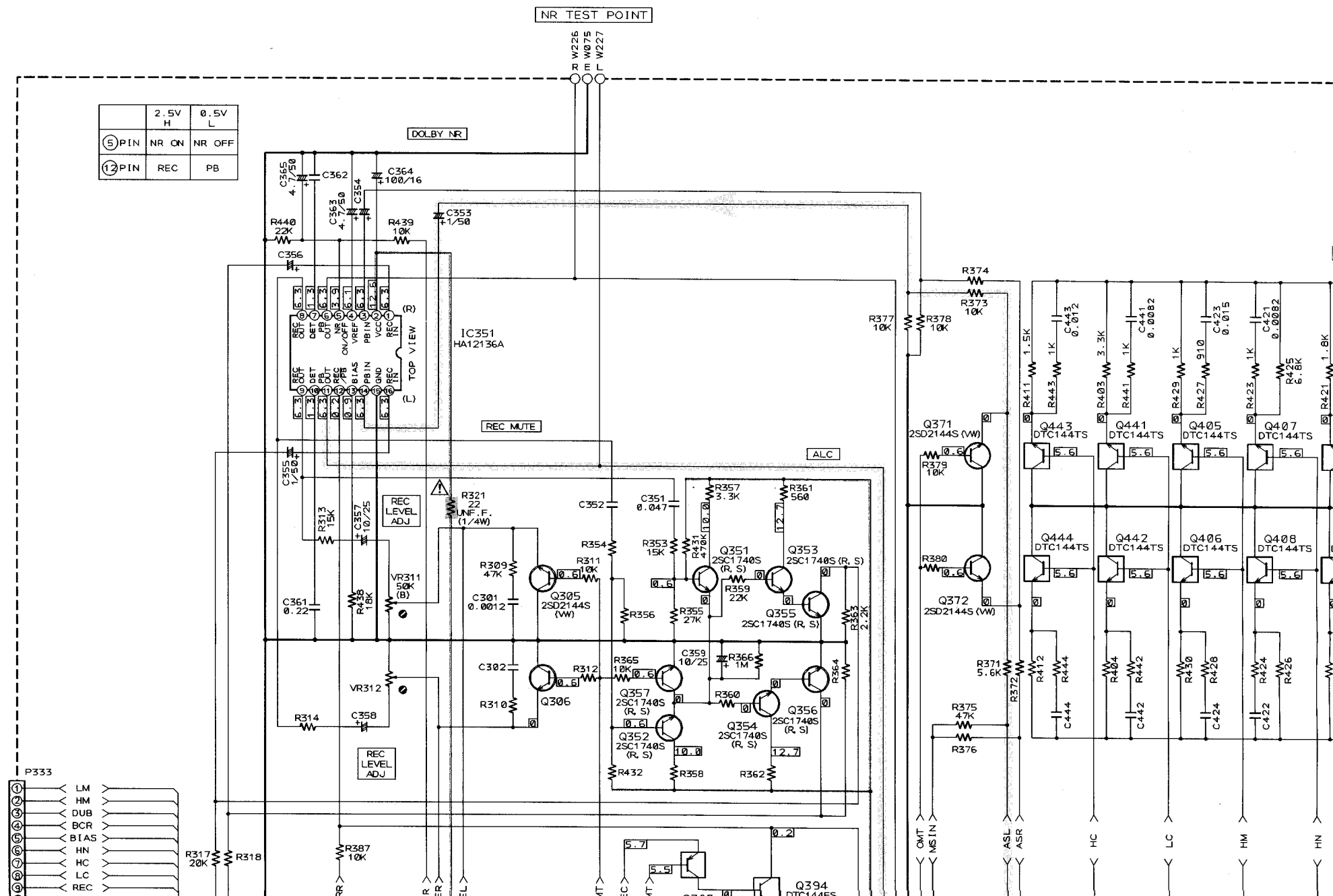

	2.5V H	0.5V L
⑤ PIN	NR ON	NR OFF
⑫ PIN	REC	PB

DOLBY NR

NR TEST POINT

REC MUTE

ALC

REC LEVEL ADJ

- P333
- 1 LM
  - 2 HM
  - 3 DUB
  - 4 BCR
  - 5 BIAS
  - 6 HN
  - 7 HC
  - 8 LC
  - 9 REC

- OMT
- MS IN
- ASL
- ASR
- HC
- LC
- HM
- HN

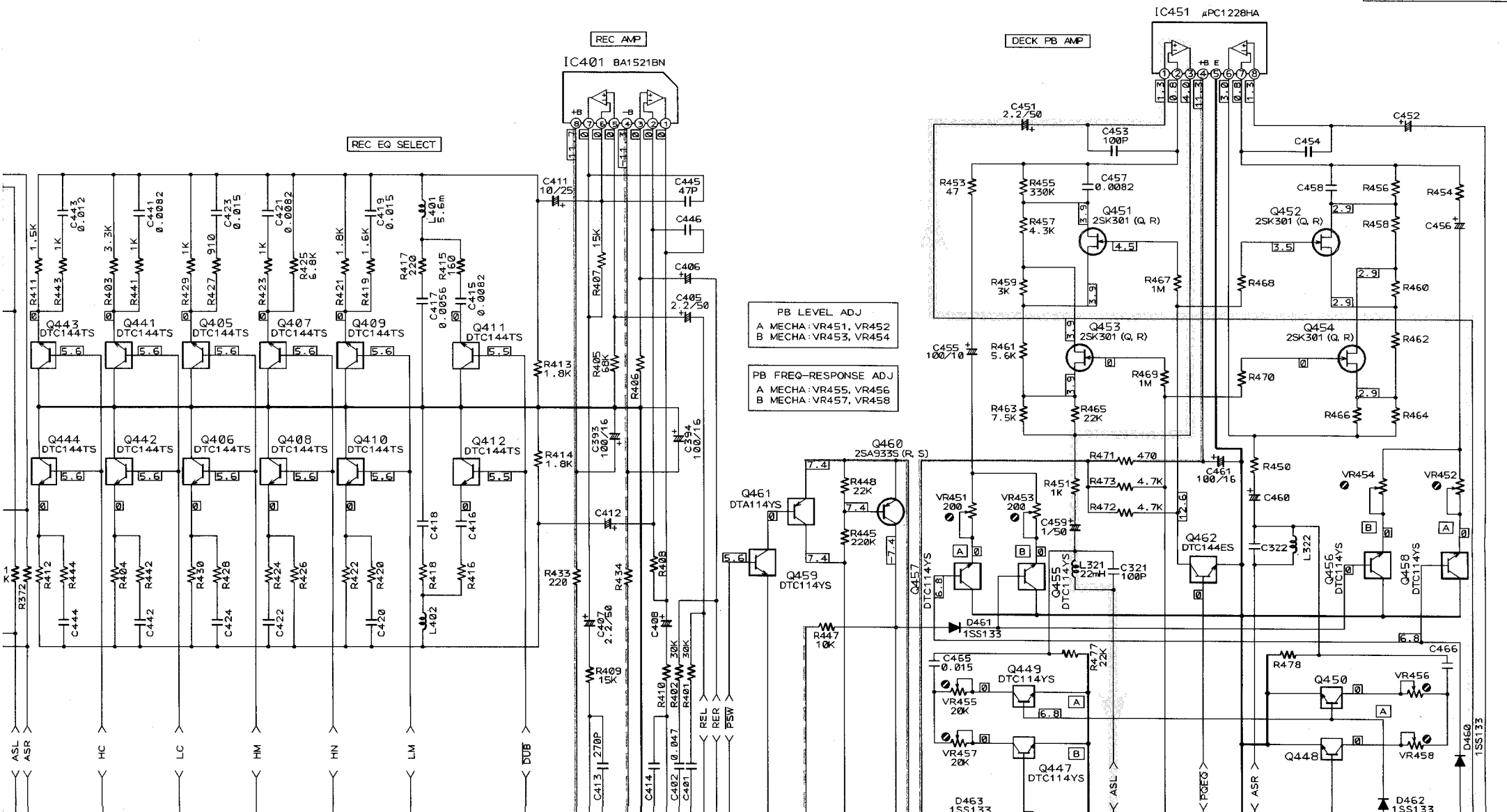

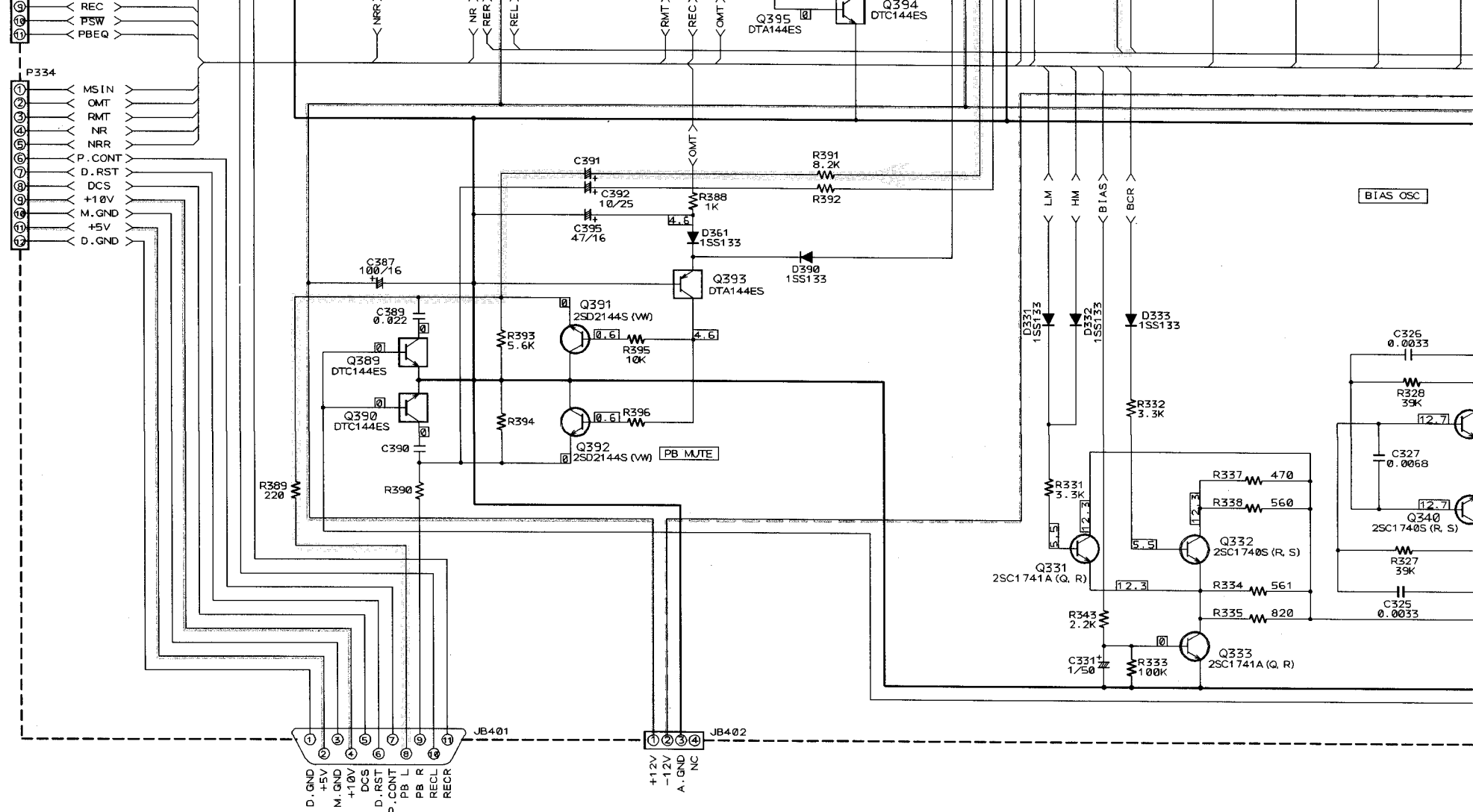

**Notes:**

1. indicates +B power supply.
2. indicates -B power supply.
3. indicates main signal path.

4. When replacing the parts in the shaded area ( ), be sure to use the designated parts for safety.
5. The design and contents are subject to change without notice.







■ Source Selector & Power Supply

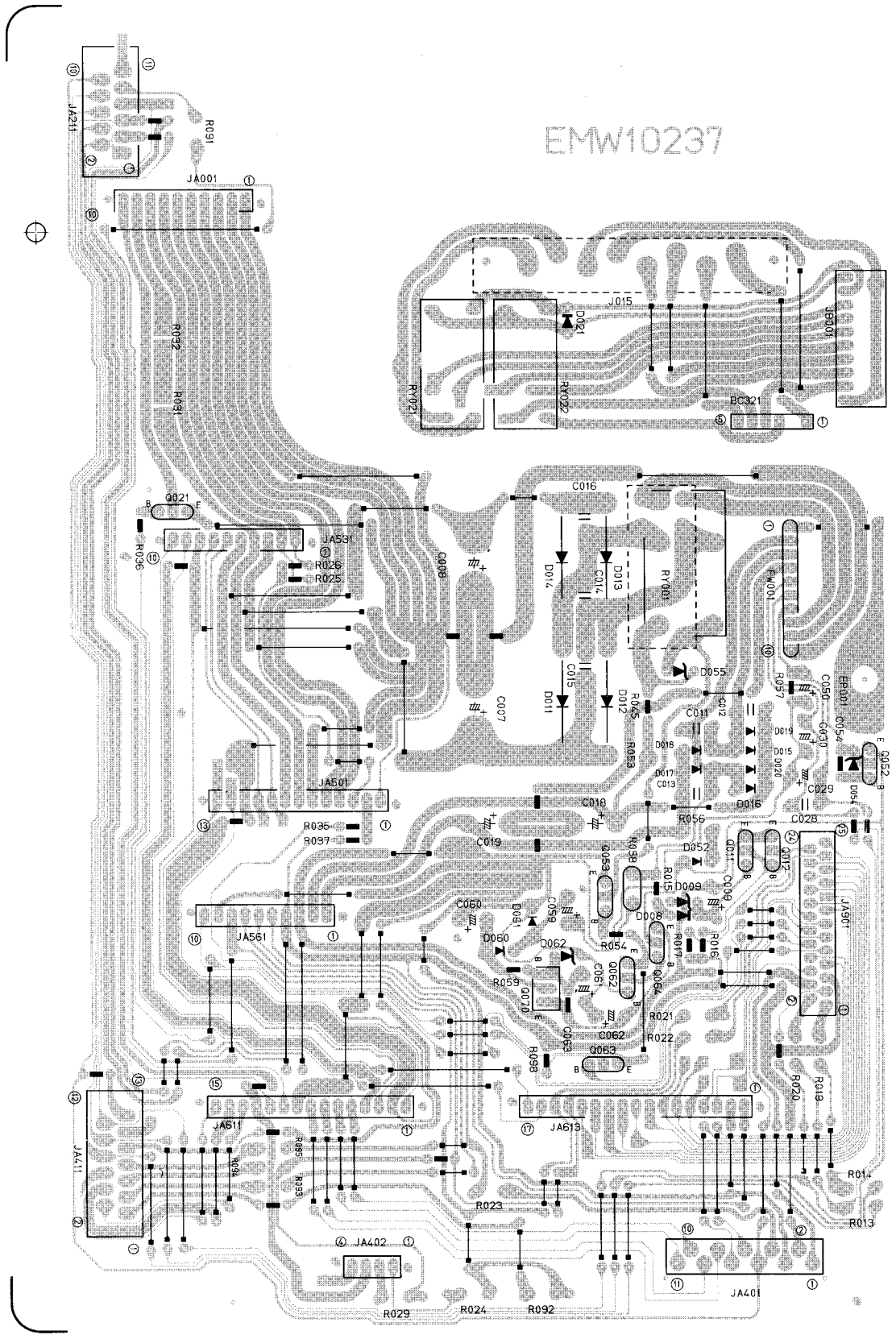

EMW10237

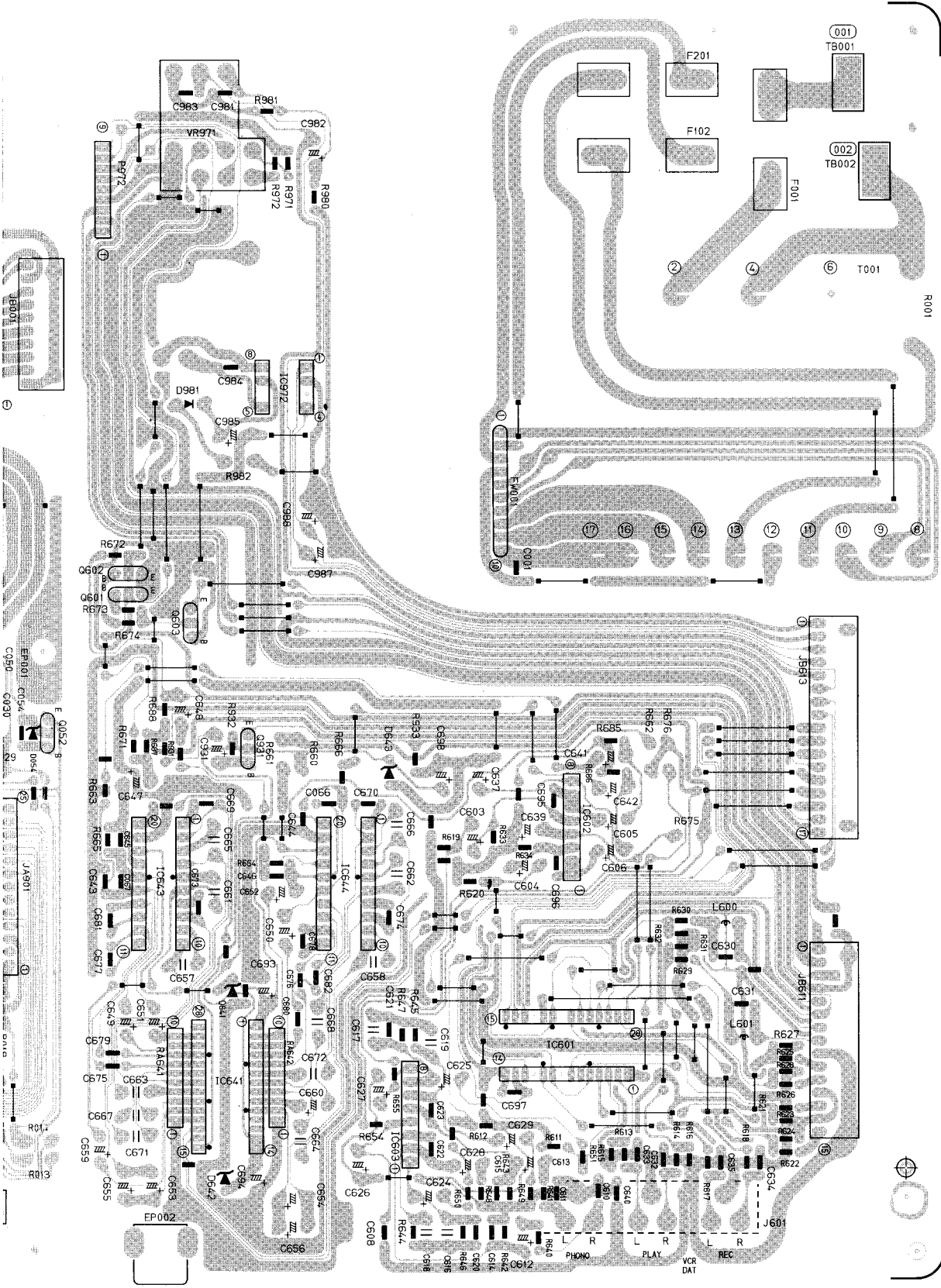





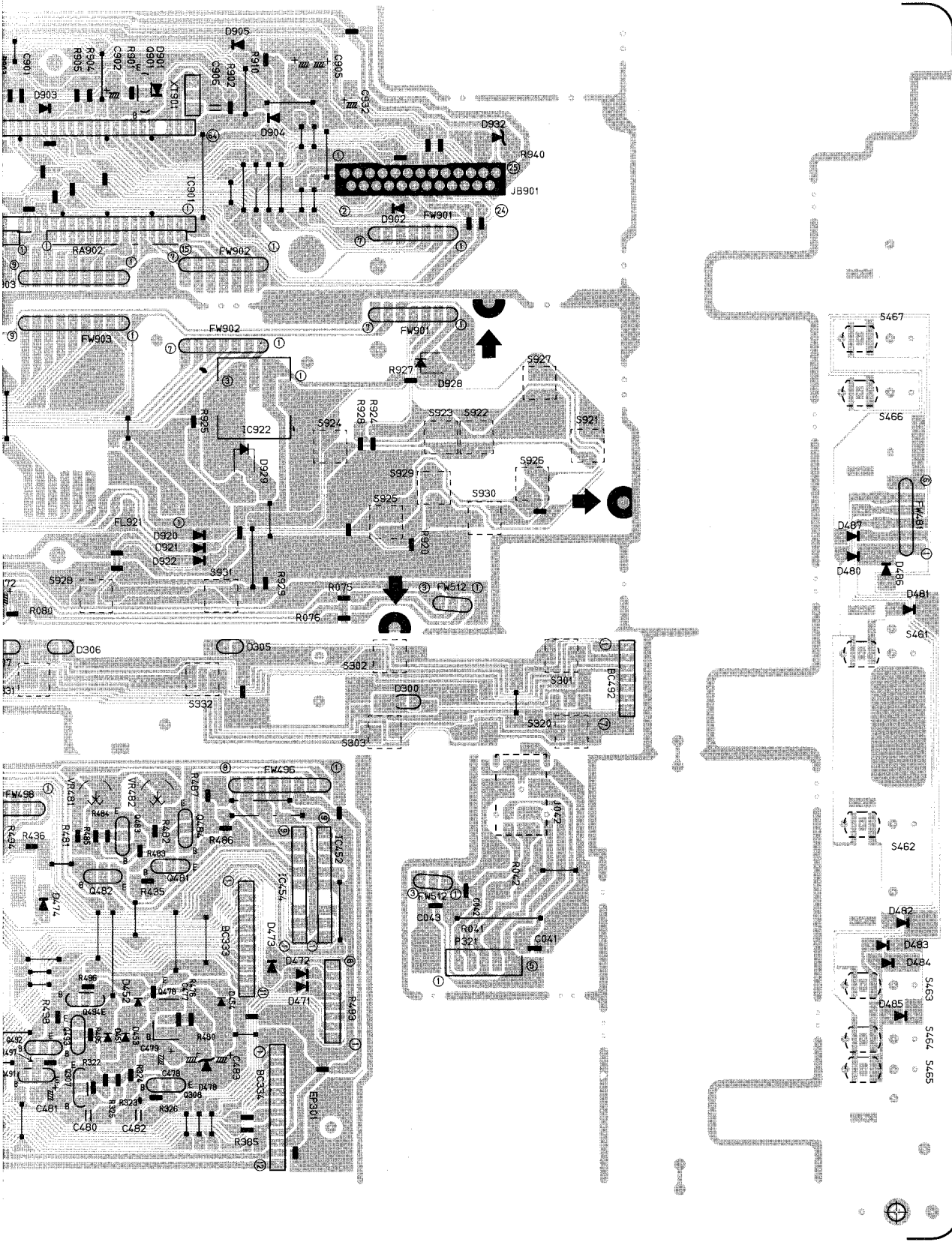

# PARTS LIST

## Contents

General Exploded View and Parts List .....	2-3
Cassette Mechanism Ass'y and Parts List .....	2-7
Printed Circuit Board Ass'y and Parts List .....	2-10
■ ENH-206 <input type="checkbox"/> Source Selector & Power Supply PC Board Ass'y .....	2-10
■ ENB-157 <input type="checkbox"/> FL Display & System Controller PC Board Ass'y .....	2-13
■ ENJ-063 <input checked="" type="checkbox"/> Cassette Deck Control & Power Amplifier PC Board Ass'y .....	2-16

# General Exploded View and Parts List

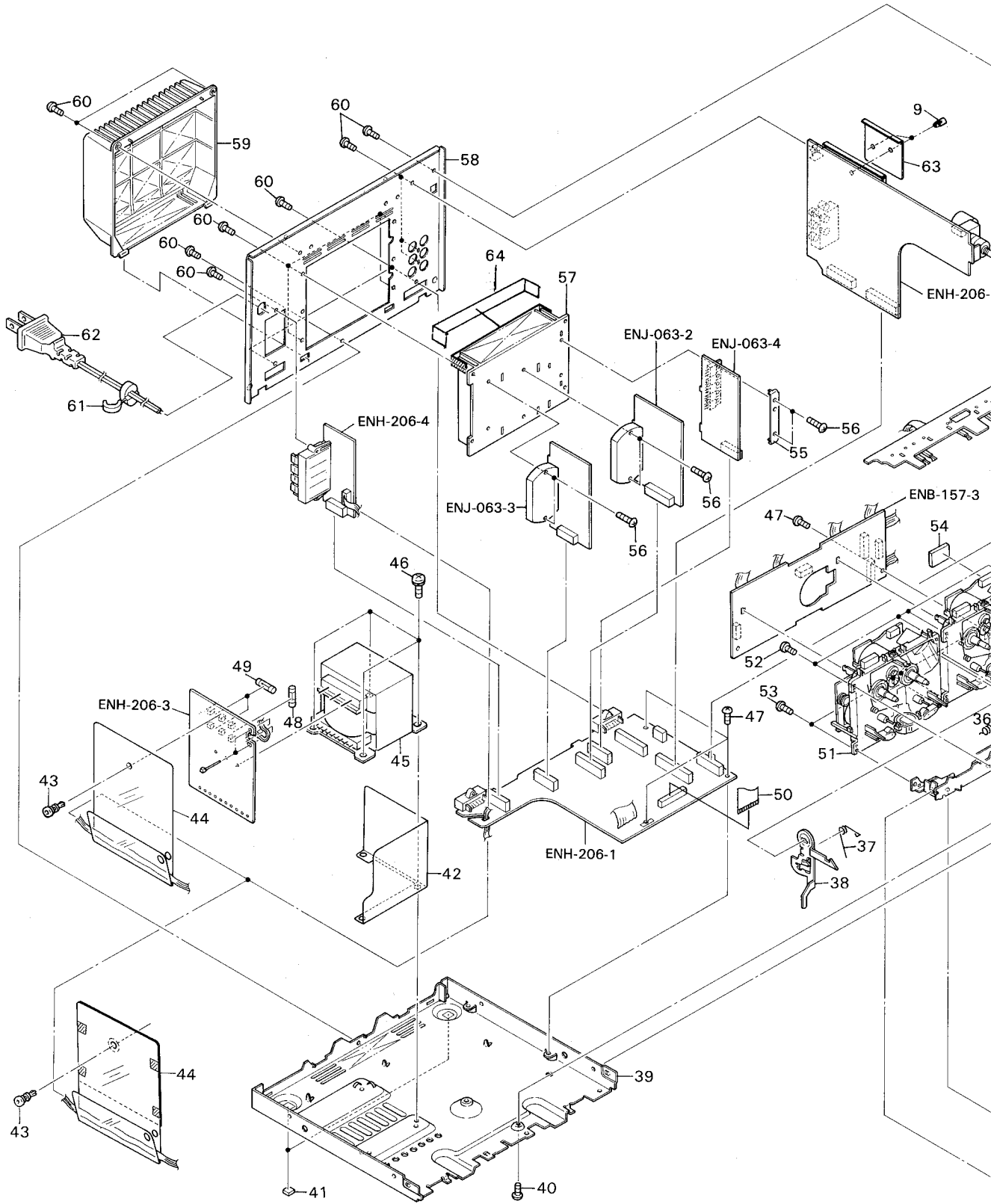

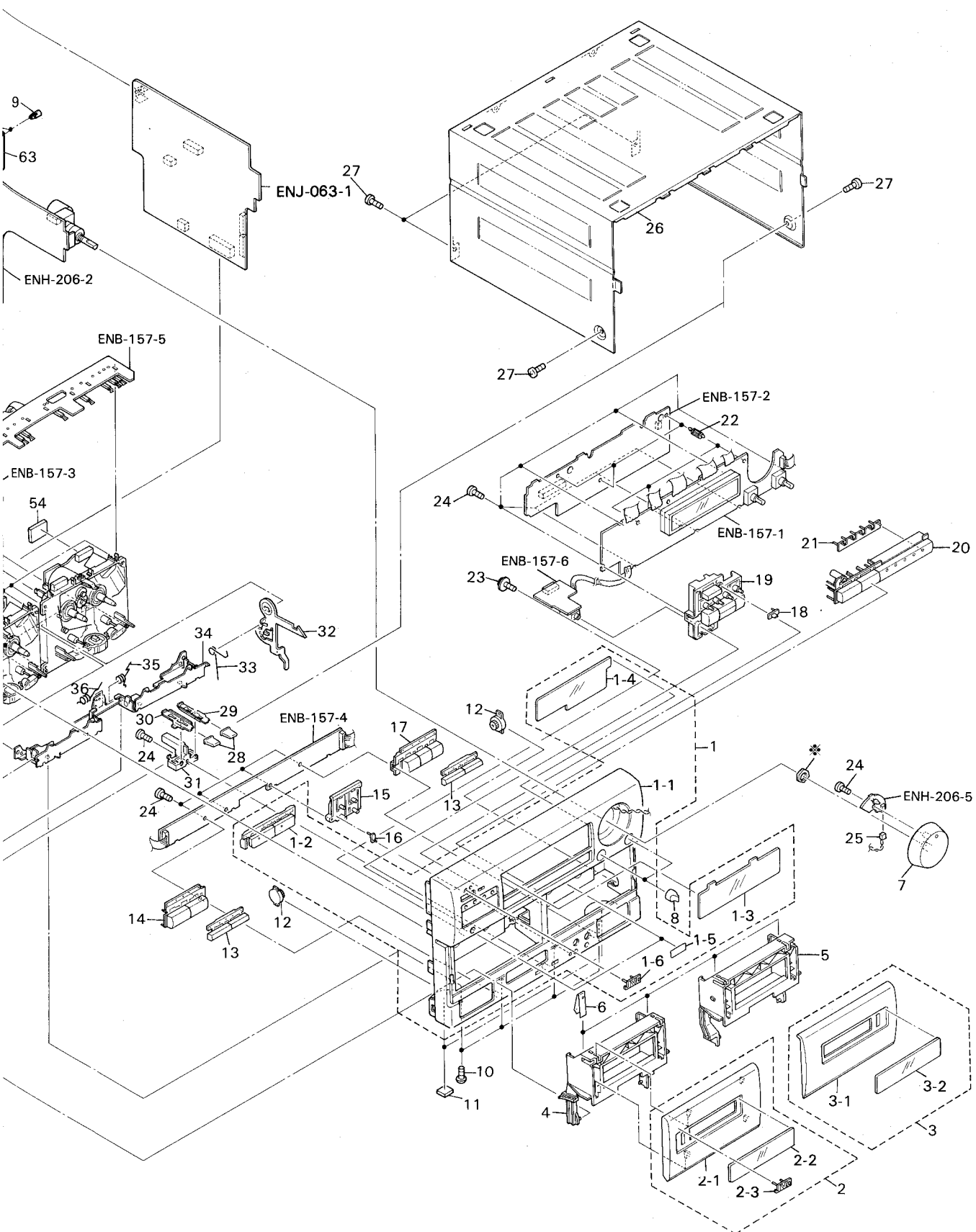

\* mark indicates attached part.

## ■ Parts List

⚠	Item	Part Number	Part Name	Q'ty	Description	Areas
	1	EFP-DXMX77MTNJS	Front Panel Ass'y	1		J
	1-1	EFP-DXMX77MTNCS	Front Panel Ass'y	1		C
	1-2	E102559-001	Front Panel	1		
	1-3	E207374-221	Push Button Ass'y	1	Dolby	
		E307965-003	Amp Window	1		J
	1-4	E307965-004	Amp Window	1		C
	1-5	E406980-002	FL Screen	1		J
	1-6	E69777-003	Reflector Plate	2		
		E406971-001	JVC Mark	1		
	2	E207365-224SA	Cassette Lid Ass'y	1	A	
	2-1	E207365-224	Cassette Lid	1	A	
	2-2	E307919-221	Cassette Window	1	A	
	2-3	E406971-001	JVC Mark	1	A	
	3	E207367-221SA	Cassette Lid Ass'y	1	B	
	3-1	E207367-221	Cassette Lid	1	B	
	3-2	E307919-221	Cassette Window	1	B	
	4	E207381-225	Cassette Holder	1	A	
	5	E207382-225	Cassette Holder	1	B	
	6	E406713-001	Cassette Spring	4		
	7	E307964-001	Volume Knob	1		
	8	E406691-002	Knob	2		
	9	E71335-001	Fastener	2		
	10	SBST3006Z	Screw	4		
	11	E406855-006	Spacer	2	Front Foot	
	12	E304434-002	Dumper Ass'y	2		
	13	E207389-221	Push Button	2	FF / Rew	
	14	E207371-221	Push Button Ass'y	1	A-Play	
	15	E207167-003	Push Button	1	Rec	
	16	E406673-001	Indicator	1		
	17	E207163-331	Push Button Ass'y	1	B-Play	
	18	E406938-221	Indicator	1	Power	
	19	E207397-001	Push Button	1	Power / SEA	
	20	E207395-001	Push Button	1	Source	
	21	E307967-001	Indicator	1	Source	
	22	E307112-001	Fastener	3		
	23	E407098-001	Special Screw	1		
	24	SDSF2610Z	Screw	13		
	25	EWS142-029	Socket Wire Ass'y	1		
	26	E207399-002	Metal Cover	1		
	27	SDSG3006M	Screw	4		
	28	E406667-003	Push Button	2	Eject	
	29	E406668-004	Push Plate	1	B	
	30	E406668-003	Push Plate	1	A	
	31	E307598-002	Eject Guide	1		
	32	E307600-002	Eject Lever	1	B	
	33	E406670-001	Eject Spring	1	B	
	34	E207153-002	Holder Bracket	1		
	35	E406672-001	Holder Spring	1	B	
	36	E406671-001	Holder Spring	1	A	
	37	E406669-001	Eject Spring	1	A	
	38	E307599-002	Eject Lever	1	A	
	39	E102561-001	Chassis Base	1		
	40	SBST3006M	Screw	1		
	41	E406855-007	Spacer	2	Rear Foot	
	42	E407086-001	Shield Cover	1	SH001	
	43	E48729-008	Plastic Rivet	1		
	44	E308088-001	Protect Cover	1		C
		E308088-002	Protect Cover	1		J
⚠	45	ETP1050-29JA	Power Transformer	1	T001	
	46	E65389-004	Special Screw	4		

⚠: Safety Parts

⚠	Item	Part Number	Part Name	Q'ty	Description	Areas
⚠	47	SBSG3008CC	Screw	4		
	48	QMF51U1-3R15S	Fuse	1	F001	
	49	QMF51U1-1R6S	Fuse	1	F101, 102	
	50	EWR125K-34TT	FFC Cable	1	FC901	
	51	_____	Cassette Mechanism Unit	1	See Page 2-7	
	52	SBSF3010C	Screw	4		
	53	SBST3008C	Screw	4		
	54	EXO014008R60S13	Spacer	1		
	55	E406969-221	Leaf Spring	1		
	56	SBSG3014CC	Screw	6		
	57	E307968-001	Heat Sink	1		
	58	E207400-001	Rear Panel	1		J
		E207400-002	Rear Panel	1		C
	59	E207356-222	Rear Cover	1		
	60	E73273-003	Special Screw	14		
	61	QHS3876-162	Cord Stopper	1		
	62	QMP1D00-200H	Power Cord	1		
	63	E407161-001	Shield Cover	1		
	64	EXO150010H09S11	Felt Spacer	1		
	—	E61029-009	Number Label	1		C
	—	E307570-001	Number Label	1		J
	—	QZL1001-001	UL Label	1		J
	—	E45858-002	CSA Label	1		C
	—	E75803-001	Fuse Caution Label	1		J
	—	E75804-001	Caution Label	1		C
	—	E407097-001	Label	1		J

⚠: Safety Parts

**The Marks Designated Areas**

J.....the U.S.A.

C.....Canada

No mark indicates all areas.

# Cassette Mechanism Ass'y and Parts List

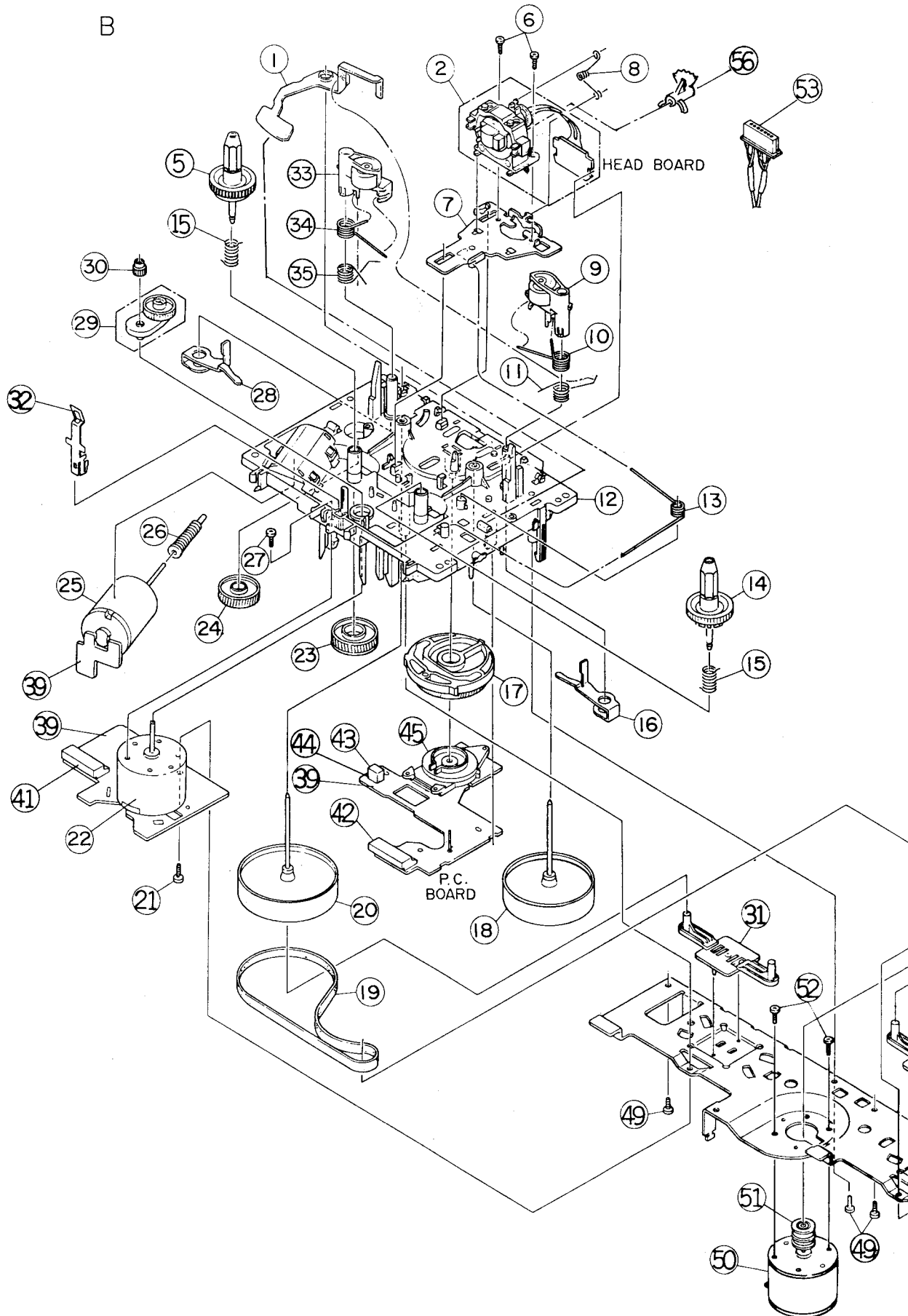



A

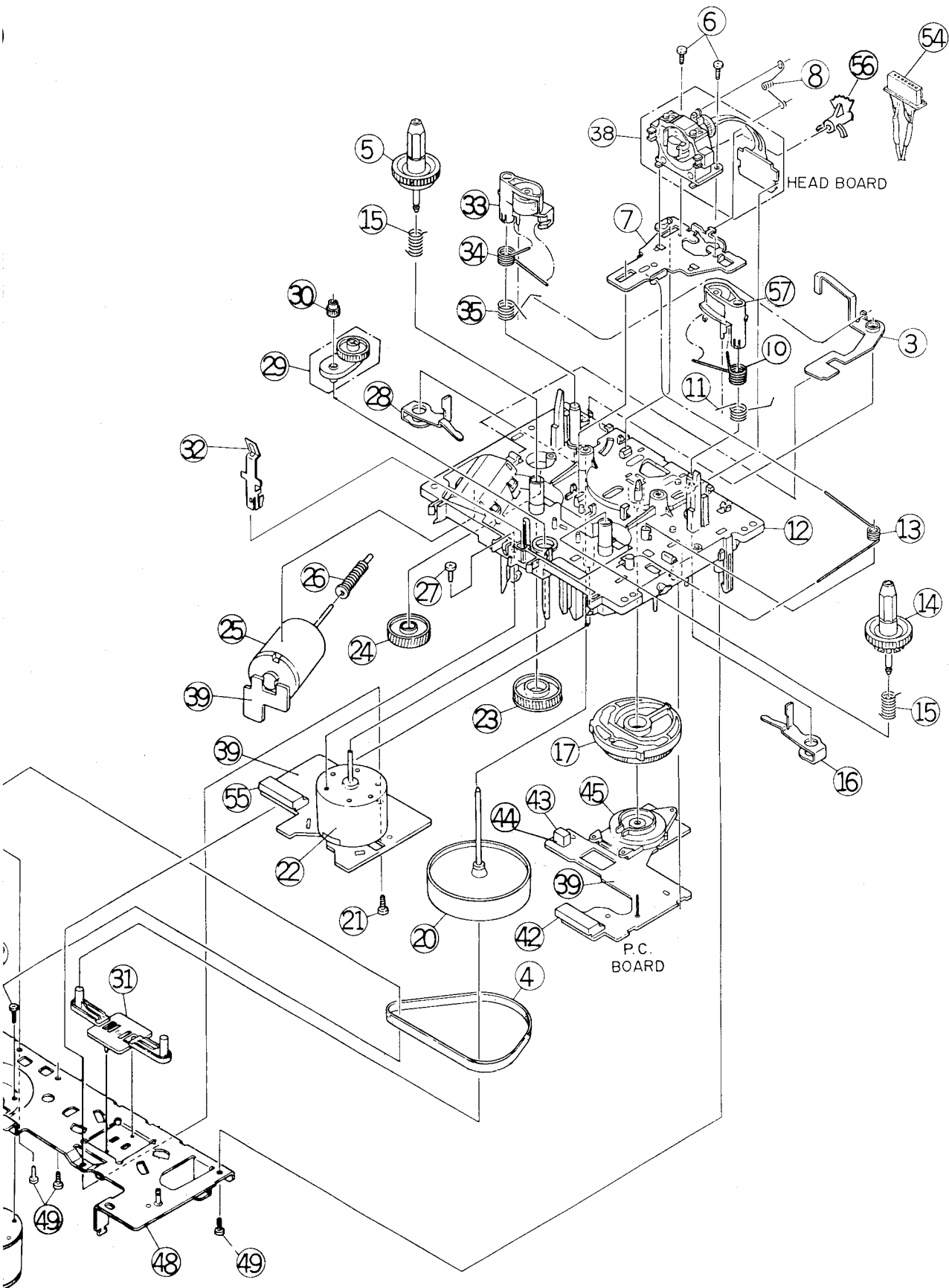

### ■ Parts List (Cassette Mechanism)

Item	Part Number	Part Name	Q'ty	Description	Areas
1	VKL7130-001	Eject Safety	1	B Mechanism	
2	VKS3551-00B	Head Mount Ass'y	1	B Mechanism	
3	VKL7131-001	Eject Safety	1	A Mechanism	
4	VKB3001-052	Belt	1	A Mechanism	
5	VKS5321-00D	Reel Ass'y	2	Right	
6	SDST2004Z	Screw	4	Head Mount Ass'y	
7	VKL6942-00E	Head Base Ass'y	2		
8	VKW4994-001	Head Spring	2		
9	VKP4221-00B	Pinch Roller Ass'y	1	B Mechanism (Left)	
10	VKW4982-001	Torsion Spring	2	B Mechanism (Left)	
11	VKW4933-004	Torsion Spring	2	Left	
12	VKS1112-30H	Chassis Base Ass'y	2		
13	VKW4930-002	Return Spring	2		
14	VKS3480-005	Reel Ass'y	2	Left	
15	VKW4928-003	B.T. Spring	4	Reel Ass'y	
16	VKL6940-002	Pinch Roller Lever	2	Left	
17	VKS2209-005	Controller Cam	2		
18	VKF3186-00C	Flywheel Ass'y	1	B Mechanism (Left)	
19	VKB3001-048	Belt	1	B Mechanism	
20	VKF3184-00C	Flywheel Ass'y	2	Right	
21	SDSF2608Z	Screw	2		
22	MMN-6F4RA38	D.C. Motor	2	Reel	
23	VKS5331-002	Gear (6)	2		
24	VKS5330-004	Gear (5)	2		
25	MXN-13FB12F	D.C. Motor	2	Cam	
26	VKS5329-002	Gear (4)	2		
27	SDSP2605Z	Screw	2		
28	VKL6939-002	Pinch Roller Lever	2	Right	
29	VKS5325-00F	FR Arm Ass'y	2		
30	VKS5328-002	Reel Motor Gear	2		
31	VKS5327-003	Trust Plate	2		
32	VKY4628-002	Pack Spring	2		
33	VKP4219-00C	Pinch Roller Ass'y	2	Right	
34	VKW4981-001	Torsion Spring	2	Right	
35	VKW4932-004	Torsion Spring	2	Right	
38	VKS3550-00B	Head Mount Ass'y	1	A Mechanism	
39	VMW2345-002	Printed Board	2		
41	VMC0107-R08	Connector	1	B Mechanism	
42	VMC0107-R07	Connector	2		
43	DN6851A	Hall IC	2		
44	VKS3487-001	IC Holder	2		
45	VKS3587-00A	Cam Switch Ass'y	2		
48	VKM3419-00E	FM Bracket	1		
49	SDSF2605Z	Screw	4		
50	MMI-6H2LW5K	Motor	1	Capstan	
51	VKR4632-002	Motor Pulley	1		
52	SPSP2603Z	Screw	2		
53	VDM007P-040I	Head Wire	1	B Mechanism	
54	VDM003P-040I	Head Wire	1	A Mechanism	
55	VMC0107-R04	Connector	1	A Mechanism	
56	VKS3485-002	Head Gear	2	A Mechanism (Left)	
57	VKP3118-002	Pinch Roller	1		



Note (1)

PC Board Ass'y	Designated Areas
ENH-206 <b>A</b>	the U.S.A.
ENH-206 <b>B</b>	Canada

Transistors

ITEM	PART NUMBER	DESCRIPTION	AREA
Q011	DTC114YS	SILICON ROHM	
Q012	DTC114YS	SILICON ROHM	
Q021	2SC1740S(R,S)	SILICON ROHM	
Q052	2SC1741A(Q,R)	SILICON ROHM	
Q053	2SC1740S(R,S)	SILICON ROHM	
Q062	DTA144ES	SILICON ROHM	
Q063	DTC143TS	SILICON ROHM	
Q064	DTC114YS	SILICON ROHM	
Q087	2SB1357(E,F)	SILICON ROHM	
Q601	2SD2144S(VW)	SILICON ROHM	
Q602	2SD2144S(VW)	SILICON ROHM	
Q603	DTA144ES	SILICON ROHM	
Q931	2SC1740S(R,S)	SILICON ROHM	

△ : SAFETY PARTS

I.C.s

ITEM	PART NUMBER	DESCRIPTION	AREA
IC601	TC9163N	I.C. TOSHIBA	
IC602	BA15218N	I.C. ROHM	
IC603	VC4580LD	I.C. DAINICHI	
IC641	LC7522	I.C. SANYO	
IC643	LA3607S	I.C. SANYO	
IC644	LA3607S	I.C. SANYO	
IC972	LB1639-CV	I.C. SANYO	

△ : SAFETY PARTS

Diodes

ITEM	PART NUMBER	DESCRIPTION	AREA
D008	1SS133	SILICON ROHM	
D009	MT25.1JC	ZENER ROHM	
D011	S3V20F	SILICON SINDENGEN	
D012	S3V20F	SILICON SINDENGEN	
D013	S3V20F	SILICON SINDENGEN	
D014	S3V20F	SILICON SINDENGEN	
D015	1SR139-200	SILICON ROHM	
D016	1SR139-200	SILICON ROHM	
D017	1SR139-200	SILICON ROHM	
D018	1SR139-200	SILICON ROHM	
D019	1SR139-200	SILICON ROHM	
D020	1SR139-200	SILICON ROHM	
D021	1SS133	SILICON ROHM	
D052	1SR139-200	SILICON ROHM	
D054	MT25.1JC	ZENER ROHM	
D055	1SS133	SILICON ROHM	
D060	1SR139-200	SILICON ROHM	
D061	1SR139-200	SILICON ROHM	
D062	MT230JC	ZENER ROHM	
D641	RD6.8JSB3	ZENER NEC	
D642	RD6.8JSB3	ZENER NEC	
D643	MT25.1JC	ZENER ROHM	
D981	1SR139-200	SILICON ROHM	

△ : SAFETY PARTS

Capacitors

ITEM	PART NUMBER	DESCRIPTION	AREA
C001	QCVB1CM-103	0.01MF 16V CERAMIC	
C007	EEW4205-688T	6800MF ELECTRO	
C008	EEW4205-688T	6800MF ELECTRO	
C009	QEK51HM-225G	2.2MF 50V ELECTRO	
C011	QFV81HJ-104	0.1MF 50V T.FILM	
C012	QFV81HJ-104	0.1MF 50V T.FILM	
C013	QFV81HJ-104	0.1MF 50V T.FILM	
C014	QFN82AK-103	0.01MF 100V MYLAR	
C015	QFN81HJ-103	0.01MF 50V MYLAR	
C016	QFN81HJ-103	0.01MF 50V MYLAR	
C018	QETB1VM-338	3300MF 35V ELECTRO	
C019	QETB1VM-228N	2200MF 35V ELECTRO	
C028	QFV81HJ-104	0.1MF 50V T.FILM	
C029	QETB1HM-106	10MF 50V ELECTRO	
C030	QETB1HM-106	10MF 50V ELECTRO	

△ : SAFETY PARTS

Capacitors

ITEM	PART NUMBER	DESCRIPTION	AREA
C050	QETB1HM-106	10MF 50V ELECTRO	
C054	QCVB1CM-103	0.01MF 16V CERAMIC	
C059	QETB1JM-227	220MF 63V ELECTRO	
C060	QETB1JM-227	220MF 63V ELECTRO	
C061	QETB1HM-226	22MF 50V ELECTRO	
C062	QETB1HM-226	22MF 50V ELECTRO	
C063	QCSB1HK-102	1000PF 50V CERAMIC	
C066	QCSB1HJ-470	47PF 50V CERAMIC	
C067	QCSB1HJ-470	47PF 50V CERAMIC	
C603	EEZ5009-106	10MF ELECTRO	
C604	EEZ5009-106	10MF ELECTRO	
C605	EEZ5009-106	10MF ELECTRO	
C606	EEZ5009-106	10MF ELECTRO	
C608	QCHB1EZ-223	0.022MF 25V CERAMIC	
C610	QCBB1HK-331	330PF 50V CERAMIC	
C611	QCBB1HK-331	330PF 50V CERAMIC	
C612	QETB1HM-475	4.7MF 50V ELECTRO	
C613	QETB1HM-475	4.7MF 50V ELECTRO	
C614	QCBB1HK-101	100PF 50V CERAMIC	
C615	QCBB1HK-101	100PF 50V CERAMIC	
C616	QFLB1HJ-182	1800PF 50V MYLAR	
C617	QFLB1HJ-182	1800PF 50V MYLAR	
C618	QFLB1HJ-682	6800PF 50V MYLAR	
C619	QFLB1HJ-682	6800PF 50V MYLAR	
C620	QCBB1HK-101	100PF 50V CERAMIC	
C621	QCBB1HK-101	100PF 50V CERAMIC	
C622	QCBB1HK-101	100PF 50V CERAMIC	
C623	QCBB1HK-101	100PF 50V CERAMIC	
C624	QETB1HM-475	4.7MF 50V ELECTRO	
C625	QETB1HM-475	4.7MF 50V ELECTRO	
C626	QETB1EM-476	47MF 25V ELECTRO	
C627	QETB1EM-476	47MF 25V ELECTRO	
C628	QETB1EM-476	47MF 25V ELECTRO	
C629	QETB1EM-476	47MF 25V ELECTRO	
C632	QCBB1HK-331	330PF 50V CERAMIC	
C633	QCBB1HK-331	330PF 50V CERAMIC	
C634	QCBB1HK-331	330PF 50V CERAMIC	
C635	QCBB1HK-331	330PF 50V CERAMIC	
C637	EEZ2505-476	47MF ELECTRO	
C639	EEZ2505-476	47MF ELECTRO	
C641	EEZ5009-106	10MF ELECTRO	
C642	EEZ5009-106	10MF ELECTRO	
C643	QCSB1HJ-470	47PF 50V CERAMIC	
C644	QCSB1HJ-470	47PF 50V CERAMIC	
C645	QCBB1HK-101	100PF 50V CERAMIC	
C646	QCBB1HK-101	100PF 50V CERAMIC	
C647	EEZ5009-106	10MF ELECTRO	
C648	EEZ5009-106	10MF ELECTRO	
C649	QETB1HM-475	4.7MF 50V ELECTRO	
C650	QETB1HM-475	4.7MF 50V ELECTRO	
C651	QETB1HM-225	2.2MF 50V ELECTRO	
C652	QETB1HM-225	2.2MF 50V ELECTRO	
C653	QETB1HM-105	1MF 50V ELECTRO	
C654	QETB1HM-105	1MF 50V ELECTRO	
C657	QFV81HJ-823	0.082MF 50V T.FILM	
C658	QFV81HJ-823	0.082MF 50V T.FILM	
C659	QEK51HM-224G	0.22MF 50V ELECTRO	
C660	QEK51HM-224G	0.22MF 50V ELECTRO	
C661	QFV81HJ-473	0.047MF 50V T.FILM	
C662	QFV81HJ-473	0.047MF 50V T.FILM	
C663	QFV81HJ-104	0.1MF 50V T.FILM	
C664	QFV81HJ-104	0.1MF 50V T.FILM	
C665	QFV81HJ-183	0.018MF 50V T.FILM	
C666	QFV81HJ-183	0.018MF 50V T.FILM	
C667	QFV81HJ-393	0.039MF 50V T.FILM	
C668	QFV81HJ-393	0.039MF 50V T.FILM	
C669	QCXB1CM-682	6800PF 16V CERAMIC	
C670	QCXB1CM-682	6800PF 16V CERAMIC	
C671	QFV81HJ-153	0.015MF 50V T.FILM	
C672	QFV81HJ-153	0.015MF 50V T.FILM	
C673	QCXB1CM-272	2700PF 16V CERAMIC	
C674	QCXB1CM-272	2700PF 16V CERAMIC	
C675	QCXB1CM-562	5600PF 16V CERAMIC	
C676	QCXB1CM-562	5600PF 16V CERAMIC	
C677	QCXB1CM-122	1200PF 16V CERAMIC	
C678	QCXB1CM-122	1200PF 16V CERAMIC	
C679	QCXB1CM-222	2200PF 16V CERAMIC	
C680	QCXB1CM-222	2200PF 16V CERAMIC	
C681	QCBB1HK-471	470PF 50V CERAMIC	
C682	QCBB1HK-471	470PF 50V CERAMIC	
C693	QETB1CM-226	22MF 16V ELECTRO	
C694	QETB1CM-226	22MF 16V ELECTRO	
C697	QCBB1HK-561	560PF 50V CERAMIC	
C698	QETB1AM-107	100MF 10V ELECTRO	
C931	QETB1HM-105	1MF 50V ELECTRO	
C981	QCVB1CM-103	0.01MF 16V CERAMIC	
C982	QETB1CM-226	22MF 16V ELECTRO	
C983	QCHB1EZ-223	0.022MF 25V CERAMIC	
C984	QCVB1CM-103	0.01MF 16V CERAMIC	
C985	QETB1AM-476	47MF 10V ELECTRO	

△ : SAFETY PARTS

Resistors

ITEM	PART NUMBER	DESCRIPTION	AREA
R001	QRC128K-275EM	2.7M 1/2W COMPOSI	
R013	QRD14CJ-1ROS	1 1/4W UNF. CARBON	
R015	QRD167J-103	10K 1/6W CARBON	
R016	QRD167J-103	10K 1/6W CARBON	
R017	QRD167J-102	1K 1/6W CARBON	
R019	QRD14CJ-8R2S	8.2 1/4W UNF. CARBON	
R020	QRD14CJ-100S	10 1/4W UNF. CARBON	
R021	QRD14CJ-391S	390 1/4W UNF. CARBON	
R022	QRD14CJ-3R9S	3.9 1/4W UNF. CARBON	
R025	QRD167J-82S	82K 1/6W CARBON	
R026	QRD167J-104	100K 1/6W CARBON	
R029	QRD14CJ-3R9S	3.9 1/4W UNF. CARBON	
R031	QRD14CJ-121S	47 1/4W UNF. CARBON	
R032	QRD12CJ-820S	82 1/2W R. NETWORK	
R035	QRD167J-222	2.2K 1/6W CARBON	
R036	QRD167J-152	1.5K 1/6W CARBON	
R037	QRD167J-103	10K 1/6W CARBON	
R045	QRD167J-122	1.2K 1/6W CARBON	A
R053	QRG022J-271A	270 2W O.M. FILM	A
R053	QRG022J-121A	120 2W O.M. FILM	B
R054	QRD167J-222	2.2K 1/6W CARBON	
R056	QRD14CJ-220S	22 1/4W UNF. CARBON	
R057	QRD167J-223	22K 1/6W CARBON	
R058	PTH61G25AR4R7M	FUSIBLE	
R059	QRD167J-332	3.3K 1/6W CARBON	
R093	QRD14CJ-3R9S	3.9 1/4W UNF. CARBON	
R094	QRD14CJ-3R9S	3.9 1/4W UNF. CARBON	
R098	QRD167J-121	120 1/6W CARBON	
R611	QRD167J-104	100K 1/6W CARBON	
R612	QRD167J-104	100K 1/6W CARBON	
R613	QRD167J-153	15K 1/6W CARBON	
R614	QRD167J-153	15K 1/6W CARBON	
R615	QRD167J-104	100K 1/6W CARBON	
R616	QRD167J-104	100K 1/6W CARBON	
R617	QRD167J-102	1K 1/6W CARBON	
R618	QRD167J-102	1K 1/6W CARBON	
R619	QRD167J-104	100K 1/6W CARBON	
R620	QRD167J-104	100K 1/6W CARBON	
R623	QRD167J-562	5.6K 1/6W CARBON	
R624	QRD167J-562	5.6K 1/6W CARBON	
R625	QRD167J-222	2.2K 1/6W CARBON	
R626	QRD167J-222	2.2K 1/6W CARBON	
R627	QRD167J-562	5.6K 1/6W CARBON	
R628	QRD167J-562	5.6K 1/6W CARBON	
R631	QRD167J-103	10K 1/6W CARBON	
R632	QRD167J-103	10K 1/6W CARBON	
R633	QRD167J-104	100K 1/6W CARBON	
R634	QRD167J-104	100K 1/6W CARBON	
R640	QRD167J-222	2.2K 1/6W CARBON	
R641	QRD167J-222	2.2K 1/6W CARBON	
R642	QRD167J-473	47K 1/6W CARBON	
R643	QRD167J-473	47K 1/6W CARBON	
R644	QRD167J-474	470K 1/6W CARBON	
R645	QRD167J-474	470K 1/6W CARBON	
R646	QRD167J-393	39K 1/6W CARBON	
R647	QRD167J-393	39K 1/6W CARBON	
R648	QRD167J-751	750 1/6W CARBON	
R649	QRD167J-751	750 1/6W CARBON	
R650	QRD167J-561	560 1/6W CARBON	
R651	QRD167J-561	560 1/6W CARBON	
R654	QRD167J-391	390 1/6W CARBON	
R655	QRD167J-391	390 1/6W CARBON	
R660	QRD14CJ-391S	390 1/4W UNF. CARBON	
R661	QRD14CJ-271S	270 1/4W UNF. CARBON	
R662	QRD14CJ-271S	270 1/4W UNF. CARBON	
R663	QRD167J-123	12K 1/6W CARBON	
R664	QRD167J-113	11K 1/6W CARBON	
R665	QRD167J-113	11K 1/6W CARBON	
R666	QRD167J-123	12K 1/6W CARBON	
R671	QRD167J-472	4.7K 1/6W CARBON	
R672	QRD167J-472	4.7K 1/6W CARBON	
R673	QRD167J-103	10K 1/6W CARBON	
R674	QRD167J-103	10K 1/6W CARBON	
R675	QRD14CJ-680S	68 1/4W UNF. CARBON	
R676	QRD14CJ-680S	68 1/4W UNF. CARBON	
R685	QRD167J-104	100K 1/6W CARBON	
R686	QRD167J-104	100K 1/6W CARBON	
R687	QRD167J-104	100K 1/6W CARBON	
R688	QRD167J-104	100K 1/6W CARBON	
R931	QRD167J-102	1K 1/6W CARBON	
R932	QRD167J-105	1M 1/6W CARBON	
R933	QRD167J-153	15K 1/6W CARBON	
R971	QRD167J-562	5.6K 1/6W CARBON	
R972	QRD167J-562	5.6K 1/6W CARBON	
R980	QRD167J-102	1K 1/6W CARBON	
R981	QRD167J-102	1K 1/6W CARBON	
R982	QRD14CJ-4R7S	4.7 1/4W UNF. CARBON	
RA641	QRB099J-474	470K 1/10W R. NETWORK	
RA642	QRB099J-474	470K 1/10W R. NETWORK	
VR971	QVDC91A-E15C	100K VARIABLE	

△ : SAFETY PARTS

Others

ITEM	PART NUMBER	DESCRIPTION	AREA
J015	EMW10237-003	PRINTED BOARD	
J601	EMB90TV-803A	SPEAKER TERMINAL	
P972	EMN00TV-608B	6P PIN JACK	
PC321	EMV5109-009A	PLUG ASSY(6PIN)	
BK601	EWS245-009	SOCKET WIRE	
EP001	E308131-001	SHIELD COVER	
EP002	E70859-001	EARTH PLATE	
EP002	E70225-002	EARTH PLATE	
FT001	EMG7331-002	FUSE CLIP	
FT002	EMG7331-002U	FUSE CLIP	
FT101	EMG7331-002	FUSE CLIP	
FT102	EMG7331-002	FUSE CLIP	
FT103	EMG7331-002U	FUSE CLIP	
FT104	EMG7331-002U	FUSE CLIP	
FW001	EWR3AE-25SST	FLAT WIRE(10PIN)	A
FW001	EWR3AB-25SST	FLAT WIRE(10PIN)	B
JA001	EMV5125-010	PLUG ASSY(10PIN)	
JA211	EMV7127-011	CONNECTOR(11PIN)	
JA401	EMV5140-011	PLUG ASSY(11PIN)	
JA402	EMV5125-004	PLUG ASSY(4PIN)	
JA411	EMV7127-013	CONNECTOR(13PIN)	
JA501	EMV5125-013	PLUG ASSY(13PIN)	
JA531	EMV5125-010	PLUG ASSY(10PIN)	
JA561	EMV5125-010	PLUG ASSY(10PIN)	
JA611	EMV5125-015	PLUG ASSY(15PIN)	
JA613	EMV5125-017	PLUG ASSY(17PIN)	
JA901	EMV7123-025	CONNECTOR(25PIN)	
JB001	EMV7125-010R	CONNECTOR(10PIN)	
JB611	EMV7125-015R	CONNECTOR(15PIN)	
JB613	EMV7125-017R	CONNECTOR(17PIN)	
RY001	ESK1D12-211M	RELAY	A
RY001	ESK1D12-212M	RELAY	B
RY021	ESK8D24-212	RELAY	
RY022	ESK8D24-212	RELAY	
TB001	EMZ4001-001	TAB	
TB002	EMZ4001-001	TAB	

△ : SAFETY PARTS

※ Use the ESK8D24-212 instead of the ESK7D24-2120 (RY021,RY022) and use the QRD14CJ-470S (47Ω 1/4W UNF.C.) for R031 and the QRD12CJ-820S (82Ω 1/2W C.) for R032 at the same time.

■ ENB-157 □ FL Display & System Controller PC Board Ass'y

Note : ENB-157 □ varies according to the areas employed. See note (1) when placing an order.

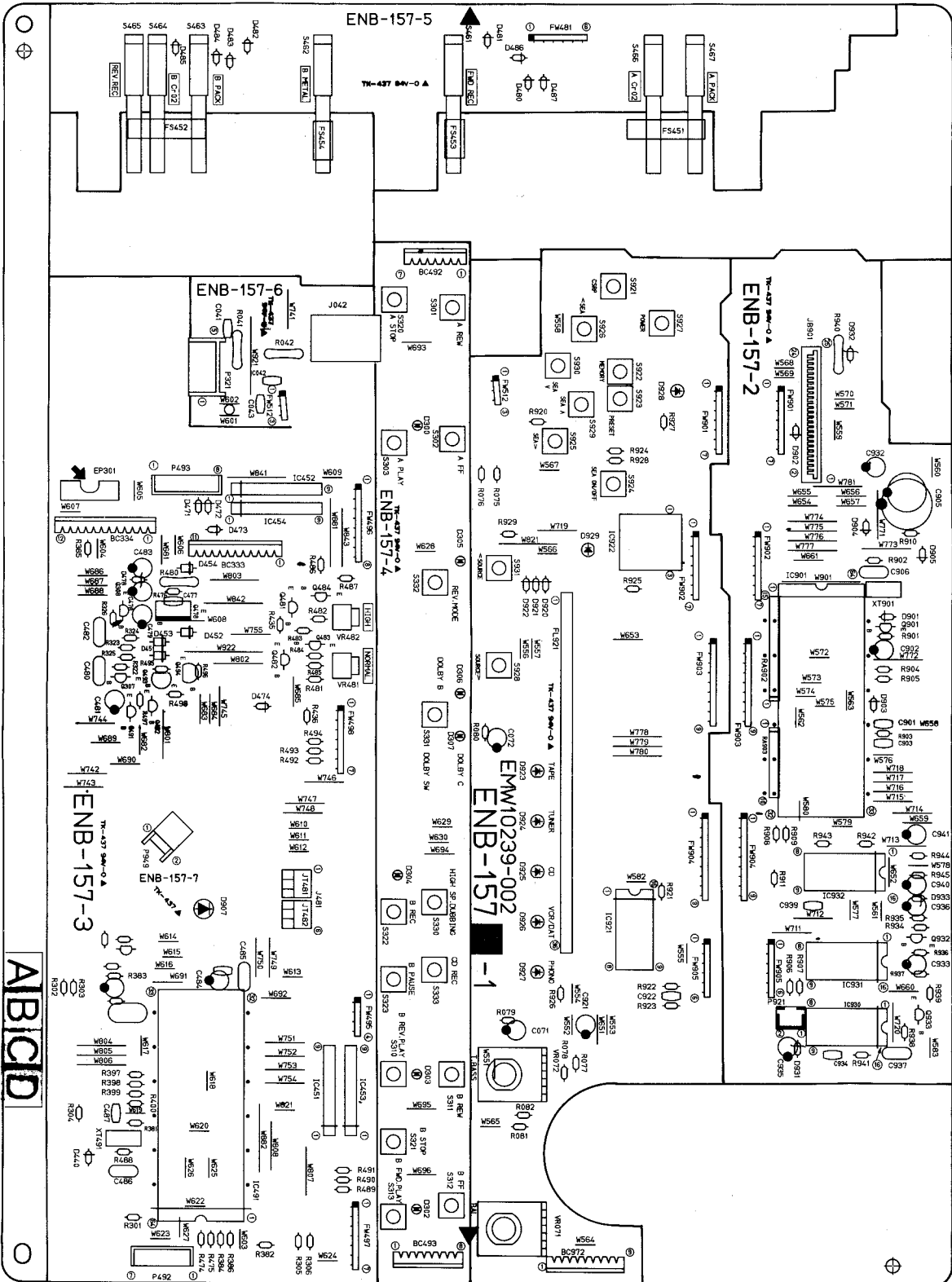

Note (1)

PC Board Ass'y	Designated Areas
ENB-157 <b>A</b>	the U.S.A.
ENB-157 <b>B</b>	Canada

Transistors

ITEM	PART NUMBER	DESCRIPTION	AREA
Q307	2SC1740S(R,S)	SILICON ROHM	
Q308	2SC1740S(R,S)	SILICON ROHM	
Q478	2SD2037(E,F)	SILICON ROHM	
Q481	2SC1740(R,S)	SILICON ROHM	
Q482	2SC1740(R,S)	SILICON ROHM	
Q483	2SA933S(R,S)	SILICON ROHM	
Q484	2SA933S(R,S)	SILICON ROHM	
Q491	DTC144ES	SILICON ROHM	
Q492	DTC144ES	SILICON ROHM	
Q493	2SA934(Q,R)	SILICON ROHM	
Q494	2SA934(Q,R)	SILICON ROHM	
Q901	DTC114YS	SILICON ROHM	
Q932	2SC1740S(R,S)	SILICON ROHM	
Q933	2SC1740S(R,S)	SILICON ROHM	

△ SAFETY PARTS

I.C.s

ITEM	PART NUMBER	DESCRIPTION	AREA
IC451	BA6218	I.C. ROHM	
IC452	BA6218	I.C. ROHM	
IC453	BA6218	I.C. ROHM	
IC454	BA6218	I.C. ROHM	
IC491	HD614081SC34	I.C. HITACHI	
IC901	MN171202JPS	I.C. MATSUSHITA	
IC921	TC74HC595AP	I.C. TOSHIBA	
IC922	SPS-420-1	I.C. SANYO	
IC930	XR1091ECP	I.C. EXAR JAPAN	
IC931	TC4052BP	I.C. TOSHIBA	
IC932	UPD7001C	I.C. NEC	

△ SAFETY PARTS

Diodes

ITEM	PART NUMBER	DESCRIPTION	AREA
D300	SLR-34MC3F	L.E.D. ROHM	
D302	SLR-34MC3F	L.E.D. ROHM	
D303	SLR-34MC3F	L.E.D. ROHM	
D304	SLR-34VC3F	L.E.D. ROHM	
D305	SLR-34VC3F	L.E.D. ROHM	
D306	SLR-34VC3F	L.E.D. ROHM	
D451	1SR139-200	SILICON ROHM	
D452	1SR139-200	SILICON ROHM	
D453	1SR139-200	SILICON ROHM	
D454	1SR139-200	SILICON ROHM	
D471	1SS133	SILICON ROHM	
D472	1SS133	SILICON ROHM	
D473	1SS133	SILICON ROHM	
D474	1SS133	SILICON ROHM	
D478	MTZ6.2JC	ZENER ROHM	
D481	1SS133	SILICON ROHM	
D482	1SS133	SILICON ROHM	
D483	1SS133	SILICON ROHM	
D484	1SS133	SILICON ROHM	
D485	1SS133	SILICON ROHM	
D486	1SS133	SILICON ROHM	
D487	1SS133	SILICON ROHM	
D901	1SS133	SILICON ROHM	
D902	1SS133	SILICON ROHM	
D903	1SS133	SILICON ROHM	
D904	1SS133	SILICON ROHM	
D905	1SS133	SILICON ROHM	
D907	LN282RPX	L.E.D.	
D920	1SS133	SILICON ROHM	
D921	1SS133	SILICON ROHM	
D922	1SS133	SILICON ROHM	
D923	SLR-34VC3F	L.E.D. ROHM	
D924	SLR-34VC3F	L.E.D. ROHM	
D925	SLR-34VC3F	L.E.D. ROHM	
D926	SLR-34VC3F	L.E.D. ROHM	
D927	SLR-34VC3F	L.E.D. ROHM	
D928	SLR-34VC3F	L.E.D. ROHM	
D929	SLR-34VC3F	L.E.D. ROHM	
D931	MTZ5.1JC	ZENER ROHM	
D932	MTZ7.5JC	ZENER ROHM	

△ SAFETY PARTS

Diodes

ITEM	PART NUMBER	DESCRIPTION	AREA
D933	MTZ5.1JC	ZENER ROHM	

△ SAFETY PARTS

Capacitors

ITEM	PART NUMBER	DESCRIPTION	AREA
C071	QEK51HM-105G	1MF 50V ELECTRO	
C072	QEK51HM-105G	1MF 50V ELECTRO	
C477	QCVB1CM-103	0.01MF 16V CERAMIC	
C478	QETB1AM-476	47MF 10V ELECTRO	
C479	QETB1AM-476	47MF 10V ELECTRO	
C480	QCF21HP-223	0.022MF 50V CERAMIC	
C481	QETB1HM-105	1MF 50V ELECTRO	
C482	QCF21HP-223	0.022MF 50V CERAMIC	
C483	QETB1CM-476	47MF 16V ELECTRO	
C484	QETB1CM-476	47MF 16V ELECTRO	
C485	QCZ0205-155	1.5MF 25V CERAMIC	
C486	QFLB1HJ-473	0.047MF 50V MYLAR	
C487	QCVB1CM-103	0.01MF 16V CERAMIC	
C901	QCVB1CM-103	0.01MF 16V CERAMIC	
C902	QETB1HM-225	2.2MF 50V ELECTRO	
C903	QCVB1CM-103	0.01MF 16V CERAMIC	
C905	QETB0JM-108	1000MF 6.3V ELECTRO	
C906	QCZ0205-155	1.5MF 25V CERAMIC	
C921	QEK51CM-107	100MF 16V ELECTRO	
C932	QETB1EM-106	10MF 25V ELECTRO	
C933	QETB1HM-474	0.47MF 50V ELECTRO	
C934	QCGB1HK-102	1000PF 50V CERAMIC	
C935	QETB1HM-474	0.47MF 50V ELECTRO	
C936	QETB1CM-476	47MF 16V ELECTRO	
C937	QFLB1HJ-104	0.1MF 50V MYLAR	
C939	QCSB1HJ-470	47PF 50V CERAMIC	
C940	QETB1EM-106	10MF 25V ELECTRO	
C941	QETB1HM-475	4.7MF 50V ELECTRO	

△ SAFETY PARTS

Resistors

ITEM	PART NUMBER	DESCRIPTION	AREA
R041	QRD12CJ-331S	330 1/2W R.NETWORK	
R042	QRD12CJ-331S	330 1/2W R.NETWORK	
R075	QRD167J-123	12K 1/6W CARBON	
R076	QRD167J-123	12K 1/6W CARBON	
R077	QRD167J-102	1K 1/6W CARBON	
R078	QRD167J-102	1K 1/6W CARBON	
R079	QRD167J-222	2.2K 1/6W CARBON	
R080	QRD167J-222	2.2K 1/6W CARBON	
R081	QRD167J-102	1K 1/6W CARBON	
R082	QRD167J-102	1K 1/6W CARBON	
R301	QRD167J-331	330 1/6W CARBON	
R302	QRD167J-331	330 1/6W CARBON	
R303	QRD167J-331	330 1/6W CARBON	
R304	QRD167J-561	560 1/6W CARBON	
R305	QRD167J-471	470 1/6W CARBON	
R306	QRD167J-471	470 1/6W CARBON	
R322	QRD167J-753	75K 1/6W CARBON	
R323	QRD167J-105	1M 1/6W CARBON	
R324	QRD167J-103	10K 1/6W CARBON	
R325	QRD167J-753	75K 1/6W CARBON	
R326	QRD167J-105	1M 1/6W CARBON	
R381	QRD167J-472	4.7K 1/6W CARBON	
R382	QRD167J-103	10K 1/6W CARBON	
R383	QRD167J-271	270 1/6W CARBON	
R384	QRD167J-103	10K 1/6W CARBON	
R385	QRD167J-151	150 1/6W CARBON	
R397	QRD167J-103	10K 1/6W CARBON	
R398	QRD167J-103	10K 1/6W CARBON	
R399	QRD167J-103	10K 1/6W CARBON	
R400	QRD167J-103	10K 1/6W CARBON	
R435	QRD167J-103	10K 1/6W CARBON	
R436	QRD167J-103	10K 1/6W CARBON	
R474	QRD167J-222	2.2K 1/6W CARBON	
R475	QRD167J-103	10K 1/6W CARBON	
R476	QRD167J-102	1K 1/6W CARBON	
R480	QRD14CJ-4R7S	4.7 1/4W UNF.CARBON	
R481	QRD167J-153	15K 1/6W CARBON	
R482	QRD167J-183	18K 1/6W CARBON	
R483	QRD167J-184	180K 1/6W CARBON	
R484	QRD167J-224	220K 1/6W CARBON	
R485	QRD167J-683	68K 1/6W CARBON	
R486	QRD167J-224	220K 1/6W CARBON	
R487	QRD167J-224	220K 1/6W CARBON	
R488	QRD167J-105	1M 1/6W CARBON	
R489	QRD167J-103	10K 1/6W CARBON	

△ SAFETY PARTS

## Resistors

△	ITEM	PART NUMBER	DESCRIPTION	AREA
	R490	QRD167J-103	10K 1/6W CARBON	
	R491	QRD167J-103	10K 1/6W CARBON	
	R492	QRD167J-103	10K 1/6W CARBON	
	R493	QRD167J-103	10K 1/6W CARBON	
	R494	QRD167J-103	10K 1/6W CARBON	
	R495	QRD167J-103	10K 1/6W CARBON	
	R496	QRD167J-103	10K 1/6W CARBON	
	R497	QRD167J-102	1K 1/6W CARBON	
	R498	QRD167J-102	1K 1/6W CARBON	
	R901	QRD167J-104	100K 1/6W CARBON	
	R902	QRD167J-103	10K 1/6W CARBON	
	R903	QRD167J-104	100K 1/6W CARBON	
	R904	QRD167J-473	47K 1/6W CARBON	
	R905	QRD167J-104	100K 1/6W CARBON	
	R906	QRD167J-473	47K 1/6W CARBON	
	R907	QRD167J-473	47K 1/6W CARBON	
	R908	QRD167J-472	4.7K 1/6W CARBON	
	R909	QRD167J-472	4.7K 1/6W CARBON	
	R910	QRD167J-101	100 1/6W CARBON	
	R911	QRD167J-182	1.8K 1/6W CARBON	
	R920	QRD167J-473	47K 1/6W CARBON	
	R921	QRD167J-223	22K 1/6W CARBON	
	R922	QRD167J-472	4.7K 1/6W CARBON	
	R923	QRD167J-103	10K 1/6W CARBON	
	R924	QRD167J-473	47K 1/6W CARBON	
	R925	QRD167J-361	360 1/6W CARBON	
	R926	QRD167J-241	240 1/6W CARBON	
	R927	QRD167J-241	240 1/6W CARBON	
	R928	QRD167J-473	47K 1/6W CARBON	
	R929	QRD167J-473	47K 1/6W CARBON	
	R934	QRD167J-683	68K 1/6W CARBON	
	R935	QRD167J-683	68K 1/6W CARBON	
	R936	QRD167J-103	10K 1/6W CARBON	
	R937	QRD167J-473	47K 1/6W CARBON	
	R938	QRD167J-562	5.6K 1/6W CARBON	
	R939	QRD167J-104	100K 1/6W CARBON	
△	R940	QRD14CJ-471S	470 1/4W UNF. CARBON	
	R941	QRD167J-152	1.5K 1/6W CARBON	
	R942	QRD167J-223	22K 1/6W CARBON	
	R943	QRD167J-273	27K 1/6W CARBON	
	R944	QRD167J-223	22K 1/6W CARBON	
	R945	QRD167J-223	22K 1/6W CARBON	
	VR071	QVJB84M-E54B	50K VARIABLE	
	VR072	QVJB84A-E53D	5K VARIABLE	
	VR481	QVPA603-103A	10K VARIABLE	
	VR482	QVPA603-203A	20K VARIABLE	

△ IS SAFETY PARTS.

## Others

△	ITEM	PART NUMBER	DESCRIPTION	AREA
	BC333	EWS32B-A912	SOCKET WIRE(11PIN)	
	BC334	EWS32C-A912	SOCKET WIRE(12PIN)	
	BC492	EWS327-A916	SOCKET WIRE(7PIN)	
	BC493	EWS328-A916	SOCKET WIRE(8PIN)	
	BC972	EWS299-0113	SOCKET WIRE(6PIN)	
	BK921	E307969-001	FL HOLDER	
	FL921	ELU0001-092	FL TUBE	
	FS921	E306805-014	FELT SPACER	
	FW481	EWR36B-13LST	FLAT WIRE(6PIN)	
	FW495	EWR34B-08LST	FLAT WIRE(4PIN)	
	FW496	EWR38B-08LST	FLAT WIRE(8PIN)	
	FW497	EWR37B-10LST	FLAT WIRE(7PIN)	
	FW498	EWR37B-10LST	FLAT WIRE(7PIN)	
	FW512	EWR33B-10SST	FLAT WIRE(3PIN)	
	FW901	EWR37B-08SST	FLAT WIRE(7PIN)	
	FW902	EWR37B-08SST	FLAT WIRE(7PIN)	
	FW903	EWR39B-08SST	FLAT WIRE(9PIN)	
	FW904	EWR39B-08SST	FLAT WIRE(9PIN)	
	FW905	EWR36B-08SST	FLAT WIRE(6PIN)	
	JB901	EMV7123-025	CONNECTOR(25PIN)	
	JT481	EMV7122-103	CONNECTOR(3PIN)	
	JT482	EMV7122-103	CONNECTOR(3PIN)	
	XT491	ECX0004-194KM	RESONATOR	
	XT901	ECX0060-000EM	RESONATOR	

△ IS SAFETY PARTS.

## Others

△	ITEM	PART NUMBER	DESCRIPTION	AREA
	J042	EMW10239-003	PRINTED BOARD	
	P321	QMS3L40-ED0H	MINI JACK	
	P492	EMV5133-005KR	PLUG ASSY(5PIN)	
	P493	EMV5142-907	PLUG ASSY(7PIN)	
	P493	EMV5142-908	PLUG ASSY(8PIN)	
	P921	EMV5103-002A	PLUG ASSY(2PIN)	
	P949	EMV5103-002B	PLUG ASSY(2PIN)	
	S301	ESP0001-023M	TACT SWITCH(A REW)	
	S302	ESP0001-023M	TACT SWITCH(A FF)	
	S303	ESP0001-023M	TACT SWITCH(A FWD PLAY)	
	S310	ESP0001-023M	TACT SWITCH(B REV PLAY)	
	S311	ESP0001-023M	TACT SWITCH(B REW)	
	S312	ESP0001-023M	TACT SWITCH(B FF)	
	S313	ESP0001-023M	TACT SWITCH(B FWD PLAY)	
	S320	ESP0001-023M	TACT SWITCH(A STOP)	
	S321	ESP0001-023M	TACT SWITCH(B STOP)	
	S322	ESP0001-023M	TACT SWITCH(B REC)	
	S323	ESP0001-023M	TACT SWITCH(B PAUSE)	
	S330	ESP0001-023M	TACT SWITCH(HIGH SPEED DUBB.)	
	S331	ESP0001-023M	TACT SWITCH(DOLBY)	
	S332	ESP0001-023M	TACT SWITCH(REV. MODE)	
	S333	ESP0001-023M	TACT SWITCH(CD REC)	
	S461	ESB1100-007	LEAF SWITCH(FWD REC)	
	S462	ESB1100-007	LEAF SWITCH(B METAL)	
	S463	ESB1100-007	LEAF SWITCH(B PACK)	
	S464	ESB1100-007	LEAF SWITCH(B CrO2)	
	S465	ESB1100-007	LEAF SWITCH(REV. REC)	
	S466	ESB1100-007	LEAF SWITCH(A CrO2)	
	S467	ESB1100-007	LEAF SWITCH(A PACK)	
	S921	ESP0001-023M	TACT SWITCH(CSRP)	
	S922	ESP0001-023M	TACT SWITCH(MEMORY)	
	S923	ESP0001-023M	TACT SWITCH(PRESET)	
	S924	ESP0001-023M	TACT SWITCH(SBA ON/OFF)	
	S925	ESP0001-023M	TACT SWITCH(SEA FREQ. UP)	
	S926	ESP0001-023M	TACT SWITCH(SEA FREQ. DOWN)	
	S927	ESP0001-023M	TACT SWITCH(POWER)	
	S928	ESP0001-023M	TACT SWITCH(SOURCE UP)	
	S929	ESP0001-023M	TACT SWITCH(SEA LEVEL UP)	
	S930	ESP0001-023M	TACT SWITCH(SBA LEVEL DOWN)	
	S931	ESP0001-023M	TACT SWITCH(SOURCE DOWN)	

△ IS SAFETY PARTS.



■ ENJ-063 A Cassette Deck Control & Power Amplifier PC Board Ass'y

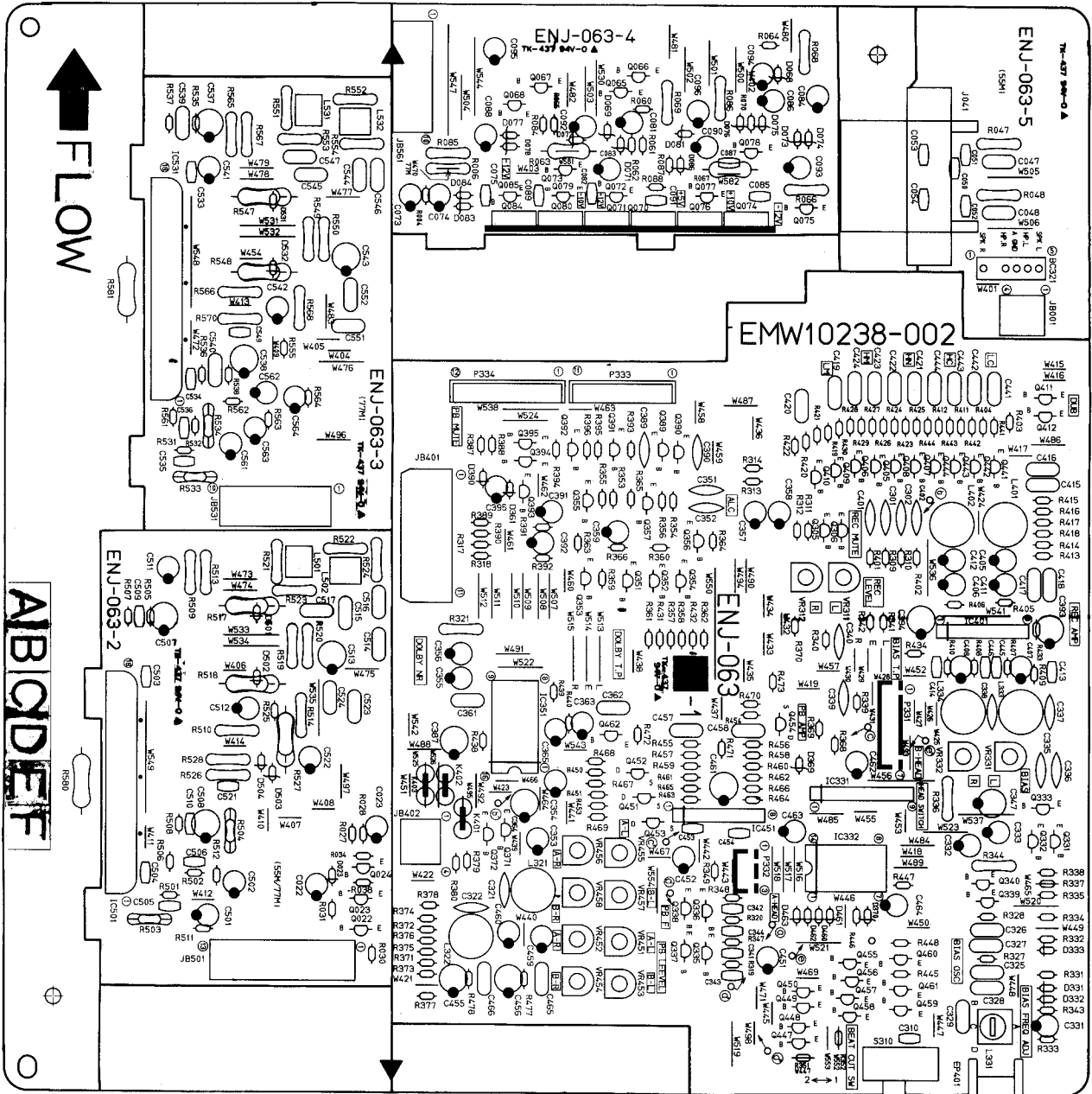

Transistors

ITEM	PART NUMBER	DESCRIPTION	AREA
Q022	2SC1740S(R,S)	SILICON ROHM	
Q023	2SC1740S(R,S)	SILICON ROHM	
Q024	2SA733A(P,Q)	SILICON NEC	
Q065	DTC144ES	SILICON ROHM	
Q066	DTA114YS	SILICON ROHM	
Q067	DTA144ES	SILICON ROHM	
Q068	DTC114YS	SILICON ROHM	
Q070	2SD2061(E,F)	SILICON ROHM	
Q071	2SD2061(E,F)	SILICON ROHM	
Q072	2SC1740S(R,S)	SILICON ROHM	
Q073	2SC1740S(R,S)	SILICON ROHM	
Q074	2SB1187(E,F)	SILICON ROHM	
Q075	2SA564A(Q,R)	SILICON MATSUSHITA	
Q076	2SD2061(E,F)	SILICON ROHM	
Q077	2SC1740S(R,S)	SILICON ROHM	

△ SAFETY PARTS

Transistors

ITEM	PART NUMBER	DESCRIPTION	AREA
Q078	2SC1740S(R,S)	SILICON ROHM	
Q079	2SA564A(Q,R)	SILICON MATSUSHITA	
Q080	2SB1187(E,F)	SILICON ROHM	
Q305	2SD2144S(VW)	SILICON ROHM	
Q306	2SD2144S(VW)	SILICON ROHM	
Q331	2SC1741A(Q,R)	SILICON ROHM	
Q332	2SC1740S(R,S)	SILICON ROHM	
Q333	2SC1741A(Q,P)	SILICON ROHM	
Q335	DTC144ES	SILICON ROHM	
Q336	DTC144ES	SILICON ROHM	
Q337	DTC144ES	SILICON ROHM	
Q338	DTC144ES	SILICON ROHM	
Q339	2SC1740S(R,S)	SILICON ROHM	
Q340	2SC1740S(R,S)	SILICON ROHM	
Q351	2SC1740S(R,S)	SILICON ROHM	

△ SAFETY PARTS

**Transistors**

Δ	ITEM	PART NUMBER	DESCRIPTION		AREA
	Q352	2SC1740S(R,S)	SILICON	ROHM	
	Q353	2SC1740S(R,S)	SILICON	ROHM	
	Q354	2SC1740S(R,S)	SILICON	ROHM	
	Q355	2SC1740S(R,S)	SILICON	ROHM	
	Q356	2SC1740S(R,S)	SILICON	ROHM	
	Q357	2SC1740S(R,S)	SILICON	ROHM	
	Q371	2SD2144S(VW)	SILICON	ROHM	
	Q372	2SD2144S(VW)	SILICON	ROHM	
	Q389	DTC144ES	SILICON	ROHM	
	Q390	DTC144ES	SILICON	ROHM	
	Q391	2SD2144S(VW)	SILICON	ROHM	
	Q392	2SD2144S(VW)	SILICON	ROHM	
	Q393	DTA144ES	SILICON	ROHM	
	Q394	DTC144ES	SILICON	ROHM	
	Q395	DTA144ES	SILICON	ROHM	
	Q405	DTC144TS	SILICON	ROHM	
	Q406	DTC144TS	SILICON	ROHM	
	Q407	DTC144TS	SILICON	ROHM	
	Q408	DTC144TS	SILICON	ROHM	
	Q409	DTC144TS	SILICON	ROHM	
	Q410	DTC144TS	SILICON	ROHM	
	Q411	DTC144TS	SILICON	ROHM	
	Q412	DTC144TS	SILICON	ROHM	
	Q441	DTC144TS	SILICON	ROHM	
	Q442	DTC144TS	SILICON	ROHM	
	Q443	DTC144TS	SILICON	ROHM	
	Q444	DTC144TS	SILICON	ROHM	
	Q447	DTC114YS	SILICON	ROHM	
	Q448	DTC114YS	SILICON	ROHM	
	Q449	DTC114YS	SILICON	ROHM	
	Q450	DTC114YS	SILICON	ROHM	
	Q451	2SK301(Q,R)	F.E.T	MATSUSHITA	
	Q452	2SK301(Q,R)	F.E.T	MATSUSHITA	
	Q453	2SK301(Q,R)	F.E.T	MATSUSHITA	
	Q454	2SK301(Q,R)	F.E.T	MATSUSHITA	
	Q455	DTC114YS	SILICON	ROHM	
	Q456	DTC114Y8	SILICON	ROHM	
	Q457	DTC114YS	SILICON	ROHM	
	Q458	DTC114YS	SILICON	ROHM	
	Q459	DTC114YS	SILICON	ROHM	
	Q460	2SA933S(R,S)	SILICON	ROHM	
	Q461	DTA114YS	SILICON	ROHM	
	Q462	DTC144ES	SILICON	ROHM	

Δ : SAFETY PARTS

**I.C.s**

Δ	ITEM	PART NUMBER	DESCRIPTION		AREA
	IC331	UPC1330HA	I.C.	NEC	
	IC332	BU4066B	I.C.	ROHM	
	IC351	HA12136A	I.C.	HITACHI	
	IC401	BA15218N	I.C.	ROHM	
	IC451	UPC1228HA	I.C.	NEC	
	IC501	STK4141MK5	I.C.	SANYO	
	IC551	STK4141MK5	I.C.	SANYO	

Δ : SAFETY PARTS

**Diodes**

Δ	ITEM	PART NUMBER	DESCRIPTION		AREA
	D023	1SS133	SILICON	ROHM	
	D071	RD13JSB3	ZENER	NEC	
	D072	MT213JC	ZENER	ROHM	
	D073	MT213JC	ZENER	ROHM	
	D074	RD13JSB3	ZENER	NEC	
	D075	MT211JC	ZENER	ROHM	
	D076	MT212JC	ZENER	ROHM	
	D077	MT211JC	ZENER	ROHM	
	D078	MT212JC	ZENER	ROHM	
	D081	MT26.8JC	ZENER	ROHM	
	D086	MT26.2JC	ZENER	ROHM	
	D331	1SS133	SILICON	ROHM	
	D332	1SS133	SILICON	ROHM	
	D333	1SS133	SILICON	ROHM	
	D361	1SS133	SILICON	ROHM	
	D369	MT27.5JC	ZENER	ROHM	
	D370	MT27.5JC	ZENER	ROHM	
	D390	1SS133	SILICON	ROHM	
	D460	1SS133	SILICON	ROHM	
	D461	1SS133	SILICON	ROHM	
	D462	1SS133	SILICON	ROHM	
	D463	1SS133	SILICON	ROHM	
	D501	1SS133	SILICON	ROHM	
	D502	1SS133	SILICON	ROHM	
	D503	MT212JC	ZENER	ROHM	

Δ : SAFETY PARTS

**Diodes**

Δ	ITEM	PART NUMBER	DESCRIPTION		AREA
	D504	1SS133	SILICON	ROHM	
	D531	1SS133	SILICON	ROHM	
	D532	1SS133	SILICON	ROHM	

Δ : SAFETY PARTS

**Capacitors**

Δ	ITEM	PART NUMBER	DESCRIPTION			AREA
	C022	QETB1CM-226	22MF	16V	ELECTRO	
	C023	QETB1AM-476	47MF	10V	ELECTRO	
	C081	QETB1EM-226	22MF	25V	ELECTRO	
	C082	QCVB1CM-103	0.01MF	16V	CERAMIC	
	C083	QETB1EM-226	22MF	25V	ELECTRO	
	C084	QETB1EM-226	22MF	25V	ELECTRO	
	C085	QCVB1CM-103	0.01MF	16V	CERAMIC	
	C086	QETB1EM-226	22MF	25V	ELECTRO	
	C087	QCVB1CM-103	0.01MF	16V	CERAMIC	
	C088	QETB1EM-226	22MF	25V	ELECTRO	
	C089	QCVB1CM-103	0.01MF	16V	CERAMIC	
	C090	QETB1EM-226	22MF	25V	ELECTRO	
	C091	QCVB1CM-103	0.01MF	16V	CERAMIC	
	C092	QETB1EM-226	22MF	25V	ELECTRO	
	C093	QETB1EM-226	22MF	25V	ELECTRO	
	C094	QETB1EM-226	22MF	25V	ELECTRO	
	C095	QETB1EM-226	22MF	25V	ELECTRO	
	C096	QETB1EM-226	22MF	25V	ELECTRO	
	C301	QCY21HK-122	1200PF	50V	CERAMIC	
	C302	QCY21HK-122	1200PF	50V	CERAMIC	
	C310	QCB1HK-471	470PF	50V	CERAMIC	
	C321	QCY21HK-101	100PF	50V	CERAMIC	
	C322	QCY21HK-101	100PF	50V	CERAMIC	
	C325	QFLB1HJ-332	3300PF	50V	MYLAR	
	C326	QFLB1HJ-332	3300PF	50V	MYLAR	
	C327	QFLB1HJ-682	6800PF	50V	MYLAR	
	C328	QFLB1HJ-153	0.015MF	50V	MYLAR	
	C329	QFPB1HG-562	5600PF	50V	POLY	
	C331	QETB1HM-105	1MF	50V	ELECTRO	
	C332	QETB1HM-105	1MF	50V	ELECTRO	
	C333	QETB1EM-106	10MF	25V	ELECTRO	
	C335	QCS21HJ-101	100PF	50V	CERAMIC	
	C336	QCS21HJ-101	100PF	50V	CERAMIC	
	C337	QCS21HJ-101	100PF	50V	CERAMIC	
	C338	QCS21HJ-101	100PF	50V	CERAMIC	
	C339	QCY21HK-122	1200PF	50V	CERAMIC	
	C340	QCY21HK-122	1200PF	50V	CERAMIC	
	C341	QCB1HK-331	330PF	50V	CERAMIC	
	C342	QCB1HK-331	330PF	50V	CERAMIC	
	C343	QCXB1CM-122	1200PF	16V	CERAMIC	
	C344	QCXB1CM-122	1200PF	16V	CERAMIC	
	C347	QETB1CM-107	100MF	16V	ELECTRO	
	C351	QCF21HP-473	0.047MF	50V	CERAMIC	
	C352	QCF21HP-473	0.047MF	50V	CERAMIC	
	C353	QETB1HM-105	1MF	50V	ELECTRO	
	C354	QETB1HM-105	1MF	50V	ELECTRO	
	C355	QETB1HM-105	1MF	50V	ELECTRO	
	C356	QETB1HM-105	1MF	50V	ELECTRO	
	C357	QETB1EM-106	10MF	25V	ELECTRO	
	C358	QETB1EM-106	10MF	25V	ELECTRO	
	C359	QETB1EM-106	10MF	25V	ELECTRO	
	C361	QFLB1HJ-224	0.22MF	50V	MYLAR	
	C362	QFLB1HJ-224	0.22MF	50V	MYLAR	
	C363	QETB1HM-475	4.7MF	50V	ELECTRO	
	C364	QETB1CM-107	100MF	16V	ELECTRO	
	C365	QETB1HM-475	4.7MF	50V	ELECTRO	
	C387	QETB1CM-107	100MF	16V	ELECTRO	
	C389	QCF21HP-223	0.022MF	50V	CERAMIC	
	C390	QCF21HP-223	0.022MF	50V	CERAMIC	
	C391	QETB1EM-106	10MF	25V	ELECTRO	
	C392	QETB1EM-106	10MF	25V	ELECTRO	
	C393	QETB1CM-107	100MF	16V	ELECTRO	
	C394	QETB1CM-107	100MF	16V	ELECTRO	
	C395	QETB1CM-476	47MF	16V	ELECTRO	
	C401	QCF21HP-473	0.047MF	50V	CERAMIC	
	C402	QCF21HP-473	0.047MF	50V	CERAMIC	
	C405	QETB1HM-225	2.2MF	50V	ELECTRO	
	C406	QETB1HM-225	2.2MF	50V	ELECTRO	
	C407	QETB1HM-225	2.2MF	50V	ELECTRO	
	C408	QETB1HM-225	2.2MF	50V	ELECTRO	
	C411	QETB1EM-106	10MF	25V	ELECTRO	
	C412	QETB1EM-106	10MF	25V	ELECTRO	
	C413	QCB1HK-271	270PF	50V	CERAMIC	
	C414	QCB1HK-271	270PF	50V	CERAMIC	
	C415	QFLB1HJ-822	8200PF	50V	MYLAR	
	C416	QFLB1HJ-822	8200PF	50V	MYLAR	
	C417	QFLB1HJ-562	5600PF	50V	MYLAR	
	C418	QFLB1HJ-562	5600PF	50V	MYLAR	
	C419	QFLB1HJ-153	0.015MF	50V	MYLAR	
	C420	QFLB1HJ-153	0.015MF	50V	MYLAR	
	C421	QFLB1HJ-822	8200PF	50V	MYLAR	
	C422	QFLB1HJ-822	8200PF	50V	MYLAR	
	C423	QFLB1HJ-153	0.015MF	50V	MYLAR	
	C424	QFLB1HJ-153	0.015MF	50V	MYLAR	
	C441	QFLB1HJ-822	8200PF	50V	MYLAR	

Δ : SAFETY PARTS

Capacitors

Δ	ITEM	PART NUMBER	DESCRIPTION	AREA
	C442	QFLB1HJ-822	8200PF 50V MYLAR	
	C443	QFLB1HJ-123	0.012MF 50V MYLAR	
	C444	QFLB1HJ-123	0.012MF 50V MYLAR	
	C445	QCSB1HJ-470	47PF 50V CERAMIC	
	C446	QCSB1HJ-470	47PF 50V CERAMIC	
	C451	QETB1HM-225	2.2MF 50V ELECTRO	
	C452	QETB1HM-225	2.2MF 50V ELECTRO	
	C453	QCBB1HK-101	100PF 50V CERAMIC	
	C454	QCBB1HK-101	100PF 50V CERAMIC	
	C455	QETB1AM-107	100MF 10V ELECTRO	
	C456	QETB1AM-107	100MF 10V ELECTRO	
	C457	QFLB1HJ-822	8200PF 50V MYLAR	
	C458	QFLB1HJ-822	8200PF 50V MYLAR	
	C459	QETB1HM-105	1MF 50V ELECTRO	
	C460	QETB1HM-105	1MF 50V ELECTRO	
	C461	QETB1CM-107	100MF 16V ELECTRO	
	C462	QETB1CM-226	22MF 16V ELECTRO	
	C463	QETB1HM-106	10MF 50V ELECTRO	
	C464	QETB1HM-106	10MF 50V ELECTRO	
	C465	QFLB1HJ-153	0.015MF 50V MYLAR	
	C466	QFLB1HJ-153	0.015MF 50V MYLAR	
	C501	EEZ5009-106	10MF ELECTRO	
	C502	EEZ5009-106	10MF ELECTRO	
	C503	QCBB1HK-101	100PF 50V CERAMIC	
	C504	QCBB1HK-101	100PF 50V CERAMIC	
	C505	QCBB1HK-101	100PF 50V CERAMIC	
	C506	QCBB1HK-101	100PF 50V CERAMIC	
	C507	QETB1HM-107	100MF 50V ELECTRO	
	C508	QETB1HM-107	100MF 50V ELECTRO	
	C509	QCT30CH-5R6	5.6PF 50V CERAMIC	
	C510	QCT30CH-5R6	5.6PF 50V CERAMIC	
	C511	QETB1HM-226	22MF 50V ELECTRO	
	C512	QETB1HM-226	22MF 50V ELECTRO	
	C513	QETB1HM-476	47MF 50V ELECTRO	
	C514	QFLB1HJ-104	0.1MF 50V MYLAR	
	C515	QFLB1HJ-104	0.1MF 50V MYLAR	
	C516	QFLB1HJ-104	0.1MF 50V MYLAR	
	C517	QFLB1HJ-104	0.1MF 50V MYLAR	
	C522	QETB1CM-226	22MF 16V ELECTRO	
	C523	QFLB1HJ-473	0.047MF 50V MYLAR	
	C524	QFLB1HJ-473	0.047MF 50V MYLAR	
	C533	QCBB1HK-101	100PF 50V CERAMIC	
	C534	QCBB1HK-101	100PF 50V CERAMIC	
	C535	QCXB1CM-392	3900PF 16V CERAMIC	
	C536	QCXB1CM-392	3900PF 16V CERAMIC	
	C537	QETB1HM-225	2.2MF 50V ELECTRO	
	C538	QETB1HM-225	2.2MF 50V ELECTRO	
	C539	QFLB1HJ-333	0.033MF 50V MYLAR	
	C540	QFLB1HJ-333	0.033MF 50V MYLAR	
	C541	QETB1HM-226	22MF 50V ELECTRO	
	C542	QETB1HM-226	22MF 50V ELECTRO	
	C543	QETB1HM-476	47MF 50V ELECTRO	
	C544	QFLB1HJ-104	0.1MF 50V MYLAR	
	C545	QFLB1HJ-104	0.1MF 50V MYLAR	
	C546	QFLB1HJ-104	0.1MF 50V MYLAR	
	C547	QFLB1HJ-104	0.1MF 50V MYLAR	
	C549	QCBB1HK-681	680PF 50V CERAMIC	
	C551	QFLB1HJ-473	0.047MF 50V MYLAR	
	C552	QFLB1HJ-473	0.047MF 50V MYLAR	
	C561	QETB1HM-474	0.47MF 50V ELECTRO	
	C562	QETB1HM-474	0.47MF 50V ELECTRO	
	C563	QETB1HM-474	0.47MF 50V ELECTRO	
	C564	QETB1HM-474	0.47MF 50V ELECTRO	

Δ IS-A-FETY PARTS

Resistors

Δ	ITEM	PART NUMBER	DESCRIPTION	AREA
	R027	QRD167J-104	100K 1/6W CARBON	
	R028	QRD167J-823	82K 1/6W CARBON	
	R030	QRD167J-473	47K 1/6W CARBON	
	R031	QRD167J-103	10K 1/6W CARBON	
	R034	QRD167J-104	100K 1/6W CARBON	
	R038	QRD167J-104	100K 1/6W CARBON	
	R060	QRD167J-103	10K 1/6W CARBON	
	R061	QRD167J-152	1.5K 1/6W CARBON	
	R062	QRD167J-471	470 1/6W CARBON	
Δ	R063	QRX012J-R68AM	0.68 1W M.FILM	
	R064	QRD167J-222	2.2K 1/6W CARBON	
	R065	QRD167J-103	10K 1/6W CARBON	
Δ	R066	QRD14CJ-2R7S	2.7 1/4W UNF.CARBON	
Δ	R067	QRX012J-R47AM	0.47 1W M.FILM	
Δ	R068	QRD14CJ-1R0S	1 1/4W UNF.CARBON	
Δ	R069	QRD14CJ-1R0S	1 1/4W UNF.CARBON	
	R070	QRD167J-332	3.3K 1/6W CARBON	
	R084	QRD167J-332	3.3K 1/6W CARBON	
Δ	R085	QRD14CJ-1R0S	1 1/4W UNF.CARBON	
Δ	R086	QRD14CJ-4R7S	4.7 1/4W UNF.CARBON	

Δ IS-A-FETY PARTS

Resistors

Δ	ITEM	PART NUMBER	DESCRIPTION	AREA
	R087	QRD167J-103	10K 1/6W CARBON	
	R088	QRD167J-103	10K 1/6W CARBON	
	R309	QRD167J-473	47K 1/6W CARBON	
	R310	QRD167J-473	47K 1/6W CARBON	
	R311	QRD167J-103	10K 1/6W CARBON	
	R312	QRD167J-103	10K 1/6W CARBON	
	R313	QRD167J-153	15K 1/6W CARBON	
	R314	QRD167J-153	15K 1/6W CARBON	
	R317	QRD167J-203	20K 1/6W CARBON	
	R318	QRD167J-203	20K 1/6W CARBON	
	R319	QRD167J-683	68K 1/6W CARBON	
	R320	QRD167J-683	68K 1/6W CARBON	
Δ	R321	QRZ0077-220	22 1/4W FUSIBLE	
	R327	QRD167J-393	39K 1/6W CARBON	
	R328	QRD167J-393	39K 1/6W CARBON	
	R331	QRD167J-332	3.3K 1/6W CARBON	
	R332	QRD167J-332	3.3K 1/6W CARBON	
	R333	QRD167J-104	100K 1/6W CARBON	
	R334	QRD167J-561	560 1/6W CARBON	
	R335	QRD167J-821	820 1/6W CARBON	
Δ	R336	QRZ0077-100	10 1/4W FUSIBLE	
	R337	QRD167J-471	470 1/6W CARBON	
	R338	QRD167J-561	560 1/6W CARBON	
	R339	QRD167J-623	62K 1/6W CARBON	
	R340	QRD167J-623	62K 1/6W CARBON	
	R341	QRD167J-100	10 1/6W CARBON	
	R342	QRD167J-100	10 1/6W CARBON	
	R343	QRD167J-222	2.2K 1/6W CARBON	
Δ	R344	QRD14CJ-6R8S	6.8 1/4W UNF.CARBON	
	R347	QRD167J-224	220K 1/6W CARBON	
	R348	QRD167J-224	220K 1/6W CARBON	
	R349	QRD167J-223	22K 1/6W CARBON	
	R351	QRD167J-102	1K 1/6W CARBON	
	R352	QRD167J-102	1K 1/6W CARBON	
	R353	QRD167J-153	15K 1/6W CARBON	
	R354	QRD167J-153	15K 1/6W CARBON	
	R355	QRD167J-243	24K 1/6W CARBON	
	R356	QRD167J-243	24K 1/6W CARBON	
	R357	QRD167J-332	3.3K 1/6W CARBON	
	R358	QRD167J-332	3.3K 1/6W CARBON	
	R359	QRD167J-223	22K 1/6W CARBON	
	R360	QRD167J-223	22K 1/6W CARBON	
	R361	QRD167J-561	560 1/6W CARBON	
	R362	QRD167J-561	560 1/6W CARBON	
	R363	QRD167J-222	2.2K 1/6W CARBON	
	R364	QRD167J-222	2.2K 1/6W CARBON	
	R365	QRD167J-103	10K 1/6W CARBON	
	R366	QRD167J-105	1M 1/6W CARBON	
	R368	QRD167J-271	270 1/6W CARBON	
	R369	QRD167J-102	1K 1/6W CARBON	
	R370	QRD167J-102	1K 1/6W CARBON	
	R371	QRD167J-562	5.6K 1/6W CARBON	
	R372	QRD167J-562	5.6K 1/6W CARBON	
	R373	QRD167J-103	10K 1/6W CARBON	
	R374	QRD167J-103	10K 1/6W CARBON	
	R375	QRD167J-473	47K 1/6W CARBON	
	R376	QRD167J-473	47K 1/6W CARBON	
	R377	QRD167J-103	10K 1/6W CARBON	
	R378	QRD167J-103	10K 1/6W CARBON	
	R379	QRD167J-103	10K 1/6W CARBON	
	R380	QRD167J-103	10K 1/6W CARBON	
	R387	QRD167J-103	10K 1/6W CARBON	
	R388	QRD167J-102	1K 1/6W CARBON	
	R389	QRD167J-221	220 1/6W CARBON	
	R390	QRD167J-221	220 1/6W CARBON	
	R391	QRD167J-822	8.2K 1/6W CARBON	
	R392	QRD167J-822	8.2K 1/6W CARBON	
	R393	QRD167J-562	5.6K 1/6W CARBON	
	R394	QRD167J-562	5.6K 1/6W CARBON	
	R395	QRD167J-103	10K 1/6W CARBON	
	R396	QRD167J-103	10K 1/6W CARBON	
	R401	QRD167J-303	30K 1/6W CARBON	
	R402	QRD167J-303	30K 1/6W CARBON	
	R403	QRD167J-332	3.3K 1/6W CARBON	
	R404	QRD167J-332	3.3K 1/6W CARBON	
	R405	QRD167J-683	68K 1/6W CARBON	
	R406	QRD167J-683	68K 1/6W CARBON	
	R407	QRD167J-153	15K 1/6W CARBON	
	R408	QRD167J-153	15K 1/6W CARBON	
	R409	QRD167J-153	15K 1/6W CARBON	
	R410	QRD167J-153	15K 1/6W CARBON	
	R411	QRD167J-152	1.5K 1/6W CARBON	
	R412	QRD167J-152	1.5K 1/6W CARBON	
	R413	QRD167J-182	1.8K 1/6W CARBON	
	R414	QRD167J-182	1.8K 1/6W CARBON	
	R415	QRD167J-161	160 1/6W CARBON	
	R416	QRD167J-161	160 1/6W CARBON	
	R417	QRD167J-221	220 1/6W CARBON	
	R418	QRD167J-221	220 1/6W CARBON	
	R419	QRD167J-162	1.6K 1/6W CARBON	
	R420	QRD167J-162	1.6K 1/6W CARBON	
	R421	QRD167J-182	1.8K 1/6W CARBON	
	R422	QRD167J-182	1.8K 1/6W CARBON	
	R423	QRD167J-102	1K 1/6W CARBON	
	R424	QRD167J-102	1K 1/6W CARBON	

Δ IS-A-FETY PARTS

Resistors

△	ITEM	PART NUMBER	DESCRIPTION			AREA
	R425	QRD167J-682	6.8K	1/6W	CARBON	
	R426	QRD167J-682	6.8K	1/6W	CARBON	
	R427	QRD167J-911	910	1/6W	CARBON	
	R428	QRD167J-911	910	1/6W	CARBON	
	R429	QRD167J-102	1K	1/6W	CARBON	
	R430	QRD167J-102	1K	1/6W	CARBON	
	R431	QRD167J-394	390K	1/6W	CARBON	
	R432	QRD167J-394	390K	1/6W	CARBON	
	R433	QRD167J-221	220	1/6W	CARBON	
	R434	QRD167J-221	220	1/6W	CARBON	
	R438	QRD167J-183	18K	1/6W	CARBON	
	R439	QRD167J-103	10K	1/6W	CARBON	
	R440	QRD167J-223	22K	1/6W	CARBON	
	R441	QRD167J-102	1K	1/6W	CARBON	
	R442	QRD167J-102	1K	1/6W	CARBON	
	R443	QRD167J-102	1K	1/6W	CARBON	
	R444	QRD167J-102	1K	1/6W	CARBON	
	R445	QRD167J-224	220K	1/6W	CARBON	
	R446	QRD167J-103	10K	1/6W	CARBON	
	R447	QRD167J-103	10K	1/6W	CARBON	
	R448	QRD167J-223	22K	1/6W	CARBON	
	R450	QRD167J-102	1K	1/6W	CARBON	
	R451	QRD167J-102	1K	1/6W	CARBON	
	R453	QRD167J-470	47	1/6W	CARBON	
	R454	QRD167J-470	47	1/6W	CARBON	
	R455	QRD167J-334	330K	1/6W	CARBON	
	R456	QRD167J-334	330K	1/6W	CARBON	
	R457	QRD167J-432	4.3K	1/6W	CARBON	
	R458	QRD167J-432	4.3K	1/6W	CARBON	
	R459	QRD167J-302	3K	1/6W	CARBON	
	R460	QRD167J-302	3K	1/6W	CARBON	
	R461	QRD167J-562	5.6K	1/6W	CARBON	
	R462	QRD167J-562	5.6K	1/6W	CARBON	
	R463	QRD167J-752	7.5K	1/6W	CARBON	
	R464	QRD167J-752	7.5K	1/6W	CARBON	
	R465	QRD167J-223	22K	1/6W	CARBON	
	R466	QRD167J-223	22K	1/6W	CARBON	
	R467	QRD167J-105	1M	1/6W	CARBON	
	R468	QRD167J-105	1M	1/6W	CARBON	
	R469	QRD167J-105	1M	1/6W	CARBON	
	R470	QRD167J-105	1M	1/6W	CARBON	
	R471	QRD167J-471	470	1/6W	CARBON	
	R472	QRD167J-472	4.7K	1/6W	CARBON	
	R473	QRD167J-472	4.7K	1/6W	CARBON	
	R477	QRD167J-223	22K	1/6W	CARBON	
	R478	QRD167J-223	22K	1/6W	CARBON	
	R501	QRD167J-104	100K	1/6W	CARBON	
	R502	QRD167J-104	100K	1/6W	CARBON	
△	R503	QRD14CJ-102S	1K	1/4W	UNF. CARBON	
△	R504	QRD14CJ-102S	1K	1/4W	UNF. CARBON	
	R505	QRD167J-471	470	1/6W	CARBON	
	R506	QRD167J-471	470	1/6W	CARBON	
	R507	QRD167J-104	100K	1/6W	CARBON	
	R508	QRD167J-104	100K	1/6W	CARBON	
△	R509	QRD14CJ-272S	2.7K	1/4W	UNF. CARBON	
△	R510	QRD14CJ-272S	2.7K	1/4W	UNF. CARBON	
	R511	QRD167J-102	1K	1/6W	CARBON	
	R512	QRD167J-102	1K	1/6W	CARBON	
△	R513	QRD14CJ-272S	2.7K	1/4W	UNF. CARBON	
△	R514	QRD14CJ-272S	2.7K	1/4W	UNF. CARBON	
△	R517	QRX012J-R22AM	0.22	1W	M.FILM	
△	R518	QRX012J-R22AM	0.22	1W	M.FILM	
△	R519	QRD14CJ-101S	100	1/4W	UNF. CARBON	
△	R520	QRZ0077-100	10	1/4W	FUSIBLE	
△	R521	QRD14CJ-100S	10	1/4W	UNF. CARBON	
△	R522	QRD14CJ-100S	10	1/4W	UNF. CARBON	
△	R523	QRD14CJ-100S	10	1/4W	UNF. CARBON	
△	R524	QRD14CJ-100S	10	1/4W	UNF. CARBON	
△	R525	QRD167J-153	15K	1/6W	CARBON	
△	R526	QRD14CJ-100S	10	1/4W	UNF. CARBON	
△	R527	QRG022J-122AM	1.2K	2W	O.M.FILM	
△	R528	QRZ0077-100	10	1/4W	FUSIBLE	
	R531	QRD167J-104	100K	1/6W	CARBON	
	R532	QRD167J-104	100K	1/6W	CARBON	
△	R533	QRD14CJ-681S	680	1/4W	UNF. CARBON	
△	R534	QRD14CJ-681S	680	1/4W	UNF. CARBON	
	R535	QRD167J-473	47K	1/6W	CARBON	
	R536	QRD167J-473	47K	1/6W	CARBON	
	R537	QRD167J-473	47K	1/6W	CARBON	
	R538	QRD167J-473	47K	1/6W	CARBON	
△	R547	QRX012J-R22AM	0.22	1W	M.FILM	
△	R548	QRX012J-R22AM	0.22	1W	M.FILM	
△	R549	QRD14CJ-101S	100	1/4W	UNF. CARBON	
△	R550	QRZ0077-100	10	1/4W	FUSIBLE	
△	R551	QRD14CJ-100S	10	1/4W	UNF. CARBON	
△	R552	QRD14CJ-100S	10	1/4W	UNF. CARBON	
△	R553	QRD14CJ-100S	10	1/4W	UNF. CARBON	
△	R554	QRD14CJ-100S	10	1/4W	UNF. CARBON	
	R555	QRD167J-103	10K	1/6W	CARBON	
	R561	QRD167J-102	1K	1/6W	CARBON	
	R562	QRD167J-102	1K	1/6W	CARBON	
	R563	QRD167J-272	2.7K	1/6W	CARBON	
	R564	QRD167J-272	2.7K	1/6W	CARBON	
△	R565	QRD14CJ-272S	2.7K	1/4W	UNF. CARBON	
△	R566	QRD14CJ-272S	2.7K	1/4W	UNF. CARBON	

△ : SAFETY PARTS

Resistors

△	ITEM	PART NUMBER	DESCRIPTION			AREA
△	R567	QRD14CJ-272S	2.7K	1/4W	UNF. CARBON	
△	R568	QRD14CJ-272S	2.7K	1/4W	UNF. CARBON	
△	R570	QRD14CJ-100S	10	1/4W	UNF. CARBON	
△	R580	QRG022J-122AM	1.2K	2W	O.M.FILM	
△	R581	QRG022J-122AM	1.2K	2W	O.M.FILM	
	VR311	QVPA601-503A	50K		VARIABLE	
	VR312	QVPA601-503A	50K		VARIABLE	
	VR331	QVPA601-503A	50K		VARIABLE	
	VR332	QVPA601-503A	50K		VARIABLE	
	VR451	QVPA601-201A	200		VARIABLE	
	VR452	QVPA601-201A	200		VARIABLE	
	VR453	QVPA601-201A	200		VARIABLE	
	VR454	QVPA601-201A	200		VARIABLE	
	VR455	QVPA601-203A	20K		VARIABLE	
	VR456	QVPA601-203A	20K		VARIABLE	
	VR457	QVPA601-203A	20K		VARIABLE	
	VR458	QVPA601-203A	20K		VARIABLE	

△ : SAFETY PARTS

Others

△	ITEM	PART NUMBER	DESCRIPTION			AREA
		EMW10238-003	PRINTED BOARD			
	L321	EQL2106-223	INDUCTOR			
	L322	EQL2106-223	INDUCTOR			
	L331	ENZ6002-012	OSCILLATOR COIL			
	L333	EQL2106-223	INDUCTOR			
	L334	EQL2106-223	INDUCTOR			
	L401	EQL2106-562	INDUCTOR			
	L402	EQL2106-562	INDUCTOR			
	L501	EQL0001-R45	INDUCTOR			
	L502	EQL0001-R45	INDUCTOR			
	L531	EQL0001-R45	INDUCTOR			
	L532	EQL0001-R45	INDUCTOR			
	P331	QMV5011-007K	PLUG ASSY(7PIN)			
	P332	QMV5011-003K	PLUG ASSY(3PIN)			
	P333	EMV5142-911	PLUG ASSY(11PIN)			
	P334	EMV5142-912	PLUG ASSY(12PIN)			
	S310	QSS6A12-E01	SLIDE SWITCH(BBAT CUT)			
	EP401	E70225-002	EARTH PLATE			
	JB401	EMV7140-L11R	CONNECTOR(11PIN)			
	JB402	EMV7125-004R	CONNECTOR(4PIN)			
	JB501	EMV7125-013R	CONNECTOR(13PIN)			
	JB531	EMV7125-010R	CONNECTOR(10PIN)			
	JB561	EMV7125-010R	CONNECTOR(10PIN)			

△ : SAFETY PARTS

**JVC**

VICTOR COMPANY OF JAPAN, LIMITED  
AUDIO DIVISION, YAMATO PLANT, 1644, SHIMOTSURUMA, YAMATO-SHI, KANAGAWA-KEN, 242, JAPAN