

JVC

SERVICE MANUAL

COMPACT COMPONENT SYSTEM

CA-MXJ55R / CA-MXJ530R

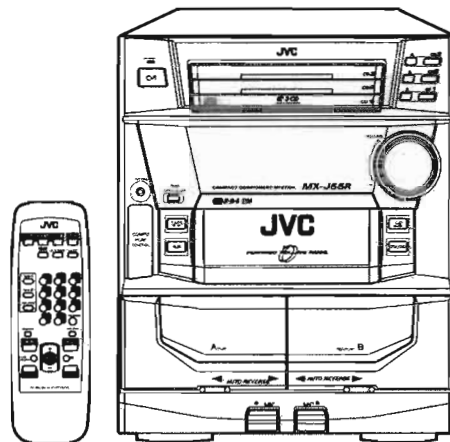

This Illustration is CA-MXJ55R

Area Suffix(CA-MXJ55R)

B U.K.
 E -- Continental Europe
 EN ---- Northern Europe
 EV ---- Eastern Europe
 EE ---- Russian Europe

Area Suffix(CA-MXJ530R)

B U.K.
 E -- Continental Europe
 EN ---- Northern Europe
 EV ---- Eastern Europe

Each difference point

Model	Color
CA-MXJ55R	Light silver
CA-MXJ530R	Light silver + Gray

COMPACT
disc
 DIGITAL AUDIO

R·D·S EON

Contents

Safety Precautions	1-2	Maintenance of laser pickup	2-36
Important for laser products	1-3	Replacement of laser pickup	2-36
Instructions	1-4	Adjustment method	2-37
Description of major ICs	2-1	Diagnosis which uses extension	
Internal connection of FL display tube ...	2-14	wire method ...	2-41
Disassembly method	2-16	Block diagram	2-42
Flow of functional operation		Standard schematic diagrams	2-43
until TOC read	2-35	Printed circuit boards	2-53
		Parts List	3-1~27

Safety Precautions

1. This design of this product contains special hardware and many circuits and components specially for safety purposes. For continued protection, no changes should be made to the original design unless authorized in writing by the manufacturer. Replacement parts must be identical to those used in the original circuits. Services should be performed by qualified personnel only.
2. Alterations of the design or circuitry of the product should not be made. Any design alterations of the product should not be made. Any design alterations or additions will void the manufacturer's warranty and will further relieve the manufacturer of responsibility for personal injury or property damage resulting therefrom.
3. Many electrical and mechanical parts in the products have special safety-related characteristics. These characteristics are often not evident from visual inspection nor can the protection afforded by them necessarily be obtained by using replacement components rated for higher voltage, wattage, etc. Replacement parts which have these special safety characteristics are identified in the Parts List of Service Manual. Electrical components having such features are identified by shading on the schematics and by (\triangle) on the Parts List in the Service Manual. The use of a substitute replacement which does not have the same safety characteristics as the recommended replacement parts shown in the Parts List of Service Manual may create shock, fire, or other hazards.
4. The leads in the products are routed and dressed with ties, clamps, tubings, barriers and the like to be separated from live parts, high temperature parts, moving parts and/or sharp edges for the prevention of electric shock and fire hazard. When service is required, the original lead routing and dress should be observed, and it should be confirmed that they have been returned to normal, after re-assembling.
5. Leakage current check (Electrical shock hazard testing)
After re-assembling the product, always perform an isolation check on the exposed metal parts of the product (antenna terminals, knobs, metal cabinet, screw heads, headphone jack, control shafts, etc.) to be sure the product is safe to operate without danger of electrical shock. Do not use a line isolation transformer during this check.
 - Plug the AC line cord directly into the AC outlet. Using a "Leakage Current Tester", measure the leakage current from each exposed metal parts of the cabinet, particularly any exposed metal part having a return path to the chassis, to a known good earth ground. Any leakage current must not exceed 0.5mA AC (r.m.s.)

- Alternate check method

Plug the AC line cord directly into the AC outlet. Use an AC voltmeter having, 1,000 ohms per volt or more sensitivity in the following manner. Connect a 1,500 Ω 10W resistor paralleled by a 0.15 μ F AC-type capacitor between an exposed metal part and a known good earth ground.

Measure the AC voltage across the resistor with the AC voltmeter.

Move the resistor connection to each exposed metal part, particularly any exposed metal part having a return path to the chassis, and measure the AC voltage across the resistor. Now reverse the plug in the AC outlet and repeat each measurement voltage measured any must not exceed 0.75 V AC (r.m.s.). This corresponds to 0.5 mA AC (r.m.s.).

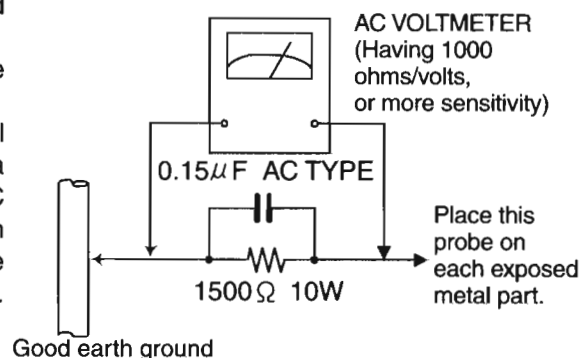

Warning

1. This equipment has been designed and manufactured to meet international safety standards.
2. It is the legal responsibility of the repairer to ensure that these safety standards are maintained.
3. Repairs must be made in accordance with the relevant safety standards.
4. It is essential that safety critical components are replaced by approved parts.
5. If mains voltage selector is provided, check setting for local voltage.

⚠ CAUTION Burrs formed during molding may be left over on some parts of the chassis. Therefore, pay attention to such burrs in the case of preforming repair of this system.

Important for laser products

1.CLASS 1 LASER PRODUCT

2.DANGER : Invisible laser radiation when open and interlock failed or defeated. Avoid direct exposure to beam.

3.CAUTION : There are no serviceable parts inside the Laser Unit. Do not disassemble the Laser Unit. Replace the complete Laser Unit if it malfunctions.

4.CAUTION : The compact disc player uses invisible laserradiation and is equipped with safety switches which prevent emission of radiation when the drawer is open and the safety interlocks have failed or are defeated. It is dangerous to defeat the safety switches.

5.CAUTION : If safety switches malfunction, the laser is able to function.

6.CAUTION : Use of controls, adjustments or performance of procedures other than those specified herein may result in hazardous radiation exposure.

CAUTION Please use enough caution not to see the beam directly or touch it in case of an adjustment or operation check.

VARNING : Osynlig laserstrålning är denna del är öppnad och spårren är urkopplad. Betrakta ej strålen.

VARO : Avattaessa ja suojalukitus ohitettaessa olet alltiina näkymättömälle lasersäteilylle. Älä katso säteeseen.

ADVARSEL : Usynlig laserstrålning ved åbning , når sikkerhedsafbrydere er ude af funktion. Undgå udsættelse for stråling.

ADVARSEL : Usynlig laserstrålning ved åpning, når sikkerhetsbryteren er avslott. unngå utsettelse for stråling.

REPRODUCTION AND POSITION OF LABELS

WARNING LABEL

DANGER : Invisible laser radiation when open and interlock or defeated.
AVOID DIRECT EXPOSURE TO BEAM (e)

VARO : Avattaessa ja suojalukitus ohitettaessa olet alltiina näkymättömälle lasersäteilylle. Älä katso säteeseen. (d)

VARNING : Osynlig laserstrålning är denna del ar öppnad och spårren är urkopplad. Betrakta ej strålen. (s)

ADVARSEL : Usynlig laserstrålning ved åbning , når sikkerhedsafbrydere er ude af funktion. Undgå udsættelse for stråling. (f)

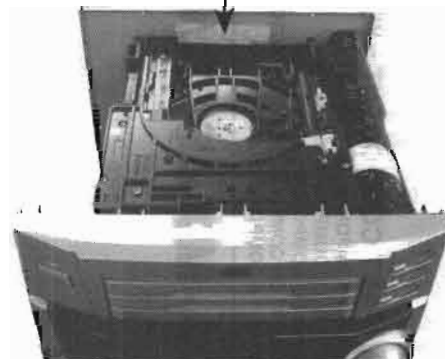
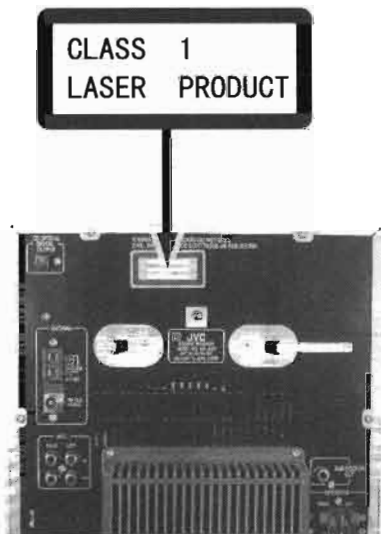

Instructions (MX-J50)

Warnings, Cautions and Others / Warnung, Achtung und sonstige Hinweise / Mises en garde, précautions et indications diverses / Waarschuwingen, voorzorgen en andere mededelingen / Avisos, precauciones y otras notas / Avvertenze e precauzioni da osservare

IMPORTANT for the UK:
DO NOT cut off the mains plug from this equipment. If the plug fitted is not suitable for the power outlet in your home or the cable is too short to reach a power point, then obtain an appropriate safety approved extension lead or consult your dealer.
BE SURE to replace the fuse only with an identical approved type, as originally fitted.
If nonetheless the mains plug is cut off ensure to remove the fuse and dispose of the plug immediately, to avoid a possible shock hazard by inadvertent connection to the mains supply.
If this product is not supplied fitted with a mains plug then follow the instructions given below.
IMPORTANT:
DO NOT make any connection to the terminal which is marked with the letter 'E' or by the safety earth symbol or coloured green or green-and-yellow.
The wire in the mains lead on this product are coloured in accordance with the following code:
Blue : Neutral
Brown : Live
As these colours may not correspond with the coloured markings identifying the terminals in your plug proceed as follows:
The wire which is coloured blue, must be connected to the terminal which is marked with the letter 'N' or coloured black.
The wire which is coloured brown must be connected to the terminal which is marked with the letter 'L' or coloured red.
IF IN DOUBT - CONSULT A COMPETENT ELECTRICIAN.

Per l'Italia:
"Si dichiara che il questo prodotto di marca JVC è conforme alle prescrizioni del Decreto Ministeriale n.548 del 28/09/95 pubblicato sulla Gazzetta Ufficiale della Repubblica Italiana n.301 del 28/12/95."



COMPACT COMPONENT SYSTEM
KOMPAKT-KOMPONENTEN-SYSTEM
SYSTEME DE COMPOSANTS COMPACT
COMPACTO COMPONENTEN-SYSTEM
SISTEMAS DE COMPONENTES COMPACTOS
IMPIANTO A COMPONENTI COMPATTO

CA-MXJ55R/CA-MXJ530R

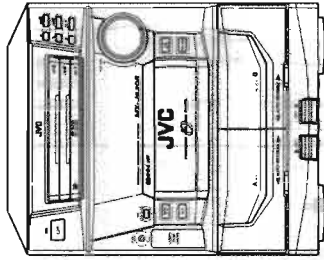

CA-MXJ530R

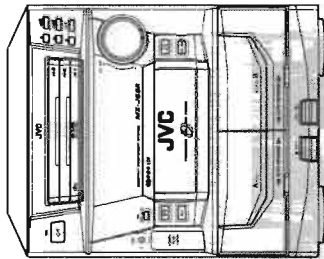

CA-MXJ55R



INSTRUCTIONS
BEDIENUNGSANLEITUNG
MANUEL D'INSTRUCTIONS
GEBRUIKSAANWIJZING
MANUAL DE INSTRUCCIONES
ISTRUZIONI

For Customer Use:
Enter below the Model No. and Serial No. which are marked on the rear bottom side of the cabinet. Retain this information for future reference.
Model No. _____
Serial No. _____

GVTD0012-006A
[E]

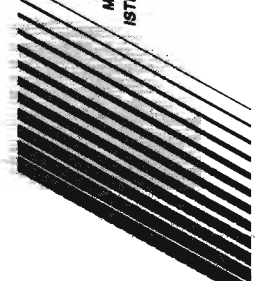

CAUTION
To reduce the risk of electrical shocks, fire, etc.:

1. Do not remove screws, covers or cabinet.
2. Do not expose this appliance to rain or moisture.

ACHTUNG
Zur Vermeidung von elektrischen Schlägen, Brandgefahr, usw.:

1. Keine Schrauben lösen oder Abdeckungen entfernen und das Gehäuse nicht feucht machen.
2. Dieses Gerät weder Regen noch Feuchtigkeit aussetzen.

ATTENTION
Afin d'éviter tout risque d'électrocution, d'incendie, etc.:

1. Ne pas enlever les vis ni les panneaux et ne pas ouvrir le coffret de l'appareil.
2. Ne pas exposer l'appareil à la pluie ni à l'humidité.

VOORZICHTIG
Om de stroomtoevoer geheel uit te schakelen, trek u de stroomtoevoer geheel uit de stroomlijn. Het apparaat kan niet worden beschermd tegen regen of vocht.

PRECAUCIÓN
Para reducir riesgo de choques eléctricos, incendio, etc.:

1. No extraiga los tornillos, los cubiertas ni la caja.
2. No exponga este aparato a la lluvia o a la humedad.

ATTENZIONE
Per ridurre il rischio di shock elettrico, incendi, ecc.:

1. Non togliete viti, coperti o la scatola.
2. Non esponete l'apparecchio alla pioggia e all'umidità.

Caution — **⚠** **switch!**
Disconnect the mains plug to shut the power off completely. The switch in any position does not disconnect the mains line. The power can be remote controlled.

Achtung — **⚠** **Schaltbar!**
Den Netzstecker aus der Steckdose ziehen, um die Stromversorgung vollkommen zu unterbrechen. Der Schalter **⚠** unterbricht in keiner Stellung die Stromversorgung vollkommen. Die Stromversorgung kann mit der Fernbedienung ein- und ausgeschaltet werden.

Atención — **⚠** **Commutador**
Desconectar el cable de alimentación para desactivar la alimentación totalmente. Cualquier que sea la posición de ajuste del interruptor **⚠**, la alimentación no se desconecta completamente. La alimentación puede ser controlada remotamente.

Attentione — **⚠** **Interruttore**
Disinserire la spina del cavo di alimentazione dalla presa della rete elettrica per staccare completamente l'alimentazione. L'interruttore **⚠** in nessuna posizione stacca la linea di alimentazione elettrica principale. È possibile il controllo remoto dell'alimentazione.

Caution — **⚠** **switch!**
Disconnect the mains plug to shut the power off completely. The switch in any position does not disconnect the mains line. The power can be remote controlled.

Achtung — **⚠** **Schaltbar!**
Den Netzstecker aus der Steckdose ziehen, um die Stromversorgung vollkommen zu unterbrechen. Der Schalter **⚠** unterbricht in keiner Stellung die Stromversorgung vollkommen. Die Stromversorgung kann mit der Fernbedienung ein- und ausgeschaltet werden.

Atención — **⚠** **Commutador**
Desconectar el cable de alimentación para desactivar la alimentación totalmente. Cualquier que sea la posición de ajuste del interruptor **⚠**, la alimentación no se desconecta completamente. La alimentación puede ser controlada remotamente.

Attentione — **⚠** **Interruttore**
Disinserire la spina del cavo di alimentazione dalla presa della rete elettrica per staccare completamente l'alimentazione. L'interruttore **⚠** in nessuna posizione stacca la linea di alimentazione elettrica principale. È possibile il controllo remoto dell'alimentazione.

Caution: Proper Ventilation
To avoid risk of electric shock and fire, and to prevent damage, locate the apparatus as follows:

- 1 Front: No obstructions and open spacing.
- 2 Side Top Bottom: No obstructions should be placed in the areas shown by the dimensions below.
- 3 Bottom: Place on the level surface. Maintain an adequate air path for ventilation by placing on a stand with a height of 10 cm or more.

Voorzichtig: Goede ventilatie vereist
Om brand, elektrische schokken en beschadiging te voorkomen, moet u het toestel als volgt opstellen:

- 1 Voorkant: Geen belemmeringen en voldoende ruimte.
- 2 Zijkant Bovenonderzijden: Geen belemmeringen plaatsen in de hieronder aangegeven zones.
- 3 Onderkant: Op vlakke ondergrond plaatsen. Voldoende ventilatieruimte voorzien door het toestel op een onderstel met een hoogte van 10 cm of meer te plaatsen.

Precaución: ventilación correcta
Para evitar el riesgo de descargas eléctricas e incendios y prevenir daños al equipo, instale el equipo en un lugar que cumpla los siguientes requisitos:

- 1 Parte frontal: Sin obstrucciones, espacio abierto.
- 2 Lado/superior/inferior: No debe haber ninguna obstrucción en las áreas mostradas por las dimensiones de la siguiente figura.
- 3 Parte inferior: Situe el equipo sobre una superficie nivelada. Mantenga un espacio adecuado para permitir el paso del aire y una correcta ventilación, situando el equipo sobre un soporte de 10 o más cm de altura.

Attention: Per una corretta ventilazione
Per prevenire il rischio di scosse elettriche e di incendio ed evitare possibili danni, collocare le apparecchiature nel modo seguente:

- 1 Parte anteriore: Nessun ostacolo e spazio libero.
- 2 Lati/Parte superiore/Inferiore: Non deve essere libera le zone indicate dalle dimensioni di seguito.
- 3 Base: Collocare su una superficie piana. Consentire un'adeguata ventilazione dell'impianto appoggiandolo su un tavolino alto almeno 10 cm.

Achtung: Akration correcte
Four prévenir tout risque de décharge électrique ou d'incendie et éviter toute détérioration, installez l'appareil de la manière suivante:

- 1 Avant: Bien dégagé de tout objet.
- 2 Côtés/sur/sous: Rien ne bloque les espaces indiqués sur la schéma ci-dessus.
- 3 Dessous: Posez l'appareil sur une surface plane et horizontale. Veillez à ce que sa ventilation correcte puisse se faire en le plaçant sur un support d'au moins dix centimètres de hauteur.

Caution: Proper Ventilation
To avoid risk of electric shock and fire, and to prevent damage, locate the apparatus as follows:

- 1 Front: No obstructions and open spacing.
- 2 Side Top Bottom: No obstructions should be placed in the areas shown by the dimensions below.
- 3 Bottom: Place on the level surface. Maintain an adequate air path for ventilation by placing on a stand with a height of 10 cm or more.

Voorzichtig: Goede ventilatie vereist
Om brand, elektrische schokken en beschadiging te voorkomen, moet u het toestel als volgt opstellen:

- 1 Voorkant: Geen belemmeringen en voldoende ruimte.
- 2 Zijkant Bovenonderzijden: Geen belemmeringen plaatsen in de hieronder aangegeven zones.
- 3 Onderkant: Op vlakke ondergrond plaatsen. Voldoende ventilatieruimte voorzien door het toestel op een onderstel met een hoogte van 10 cm of meer te plaatsen.

Precaución: ventilación correcta
Para evitar el riesgo de descargas eléctricas e incendios y prevenir daños al equipo, instale el equipo en un lugar que cumpla los siguientes requisitos:

- 1 Parte frontal: Sin obstrucciones, espacio abierto.
- 2 Lado/superior/inferior: No debe haber ninguna obstrucción en las áreas mostradas por las dimensiones de la siguiente figura.
- 3 Parte inferior: Situe el equipo sobre una superficie nivelada. Mantenga un espacio adecuado para permitir el paso del aire y una correcta ventilación, situando el equipo sobre un soporte de 10 o más cm de altura.

Attention: Per una corretta ventilazione
Per prevenire il rischio di scosse elettriche e di incendio ed evitare possibili danni, collocare le apparecchiature nel modo seguente:

- 1 Parte anteriore: Nessun ostacolo e spazio libero.
- 2 Lati/Parte superiore/Inferiore: Non deve essere libera le zone indicate dalle dimensioni di seguito.
- 3 Base: Collocare su una superficie piana. Consentire un'adeguata ventilazione dell'impianto appoggiandolo su un tavolino alto almeno 10 cm.

Achtung: Akration correcte
Four prévenir tout risque de décharge électrique ou d'incendie et éviter toute détérioration, installez l'appareil de la manière suivante:

- 1 Avant: Bien dégagé de tout objet.
- 2 Côtés/sur/sous: Rien ne bloque les espaces indiqués sur la schéma ci-dessus.
- 3 Dessous: Posez l'appareil sur une surface plane et horizontale. Veillez à ce que sa ventilation correcte puisse se faire en le plaçant sur un support d'au moins dix centimètres de hauteur.

Caution: Proper Ventilation
To avoid risk of electric shock and fire, and to prevent damage, locate the apparatus as follows:

- 1 Front: No obstructions and open spacing.
- 2 Side Top Bottom: No obstructions should be placed in the areas shown by the dimensions below.
- 3 Bottom: Place on the level surface. Maintain an adequate air path for ventilation by placing on a stand with a height of 10 cm or more.

Voorzichtig: Goede ventilatie vereist
Om brand, elektrische schokken en beschadiging te voorkomen, moet u het toestel als volgt opstellen:

- 1 Voorkant: Geen belemmeringen en voldoende ruimte.
- 2 Zijkant Bovenonderzijden: Geen belemmeringen plaatsen in de hieronder aangegeven zones.
- 3 Onderkant: Op vlakke ondergrond plaatsen. Voldoende ventilatieruimte voorzien door het toestel op een onderstel met een hoogte van 10 cm of meer te plaatsen.

Precaución: ventilación correcta
Para evitar el riesgo de descargas eléctricas e incendios y prevenir daños al equipo, instale el equipo en un lugar que cumpla los siguientes requisitos:

- 1 Parte frontal: Sin obstrucciones, espacio abierto.
- 2 Lado/superior/inferior: No debe haber ninguna obstrucción en las áreas mostradas por las dimensiones de la siguiente figura.
- 3 Parte inferior: Situe el equipo sobre una superficie nivelada. Mantenga un espacio adecuado para permitir el paso del aire y una correcta ventilación, situando el equipo sobre un soporte de 10 o más cm de altura.

Attention: Per una corretta ventilazione
Per prevenire il rischio di scosse elettriche e di incendio ed evitare possibili danni, collocare le apparecchiature nel modo seguente:

- 1 Parte anteriore: Nessun ostacolo e spazio libero.
- 2 Lati/Parte superiore/Inferiore: Non deve essere libera le zone indicate dalle dimensioni di seguito.
- 3 Base: Collocare su una superficie piana. Consentire un'adeguata ventilazione dell'impianto appoggiandolo su un tavolino alto almeno 10 cm.

Achtung: Akration correcte
Four prévenir tout risque de décharge électrique ou d'incendie et éviter toute détérioration, installez l'appareil de la manière suivante:

- 1 Avant: Bien dégagé de tout objet.
- 2 Côtés/sur/sous: Rien ne bloque les espaces indiqués sur la schéma ci-dessus.
- 3 Dessous: Posez l'appareil sur une surface plane et horizontale. Veillez à ce que sa ventilation correcte puisse se faire en le plaçant sur un support d'au moins dix centimètres de hauteur.

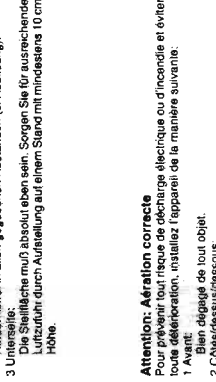
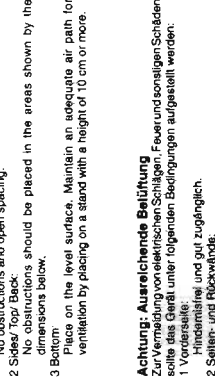

Contents

Location of the Buttons and Controls	3
Front Panel.....	4
Remote Control.....	5
Getting Started	6
Unpacking.....	6
Putting the Batteries into the Remote Control.....	6
Connecting Antennas.....	6
Connecting Speakers.....	7
Connecting Other Equipment.....	8
Common Operations	9
Setting the Clock.....	9
Turning On the Power and Selecting the Sources.....	9
Adjusting the Volume.....	10
Reinforcing the Bass Sound.....	10
Selecting the Sound Modes.....	10
Creating Your Own Sound Mode.....	11
— Manual Mode.....	11
Listening to FM and AM (MW/LW) Broadcasts	12
Tuning in a Station.....	12
Presetting Stations.....	12
Tuning in a Preset Station.....	12
Receiving FM Stations with RDS	13
Changing the RDS Information.....	13
Searching for Programs by PTY Codes (PTY Search).....	13
Switching to a Program Type of Your Choice Temporarily.....	14
Playing Back CDs	15
Loading CDs.....	15
Playing Back the Entire Discs.....	15
Continuous Play.....	15
Basic CD Operations.....	15
Programming the Playing Order of the Tracks.....	16
— Program Play.....	16
— Playing at Random — Random Play.....	17
— Repeating Tracks or CDs — Repeat Play.....	17
— Prohibiting Disc Ejection — Tray Lock.....	17
Playing Back Tapes	18
Playing Back a Tape.....	18
Locating the Beginning of a Song — Music Scan.....	18
Recording	19
Recording Tapes on Deck B.....	19
Dubbing Tapes.....	20
CD Direct Recording.....	20
Auto Edit Recording.....	21
Using the Timers	22
Using Daily Timer.....	22
Using Recording Timer.....	23
Using Sleep Timer.....	24
Timer Priority.....	24
Additional Information	25
Maintenance.....	25
Troubleshooting	26
Specifications	26

English
English



Location of the Buttons and Controls

Become familiar with the buttons and controls on your unit.

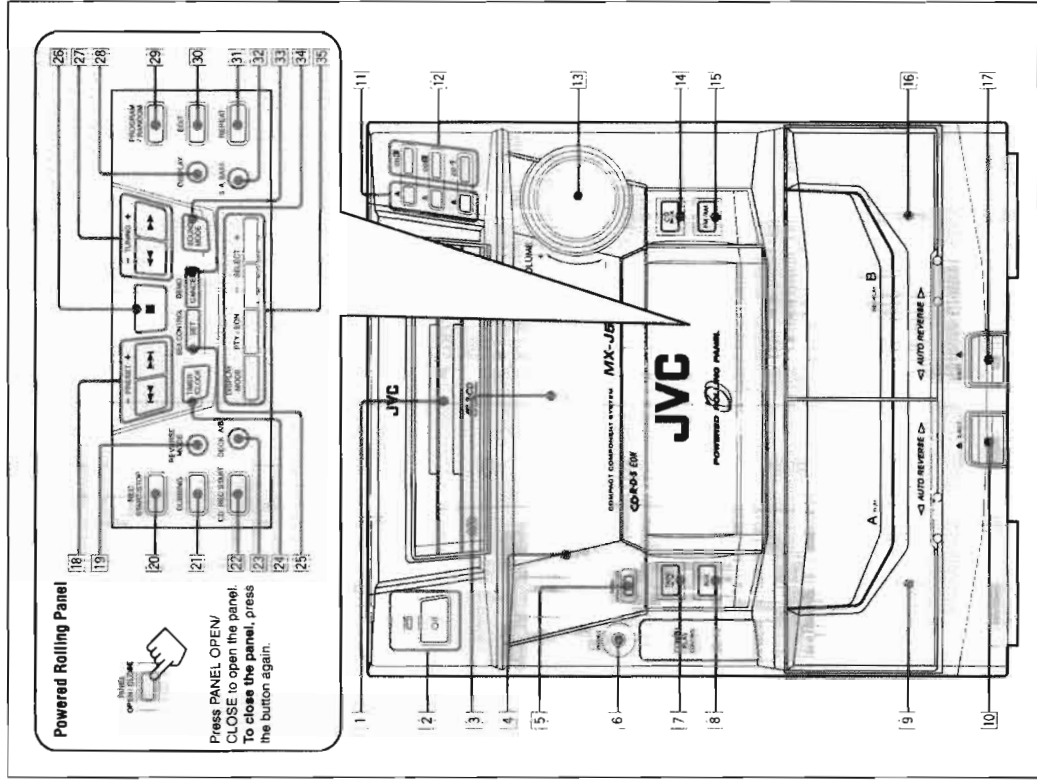



English
English

Continued

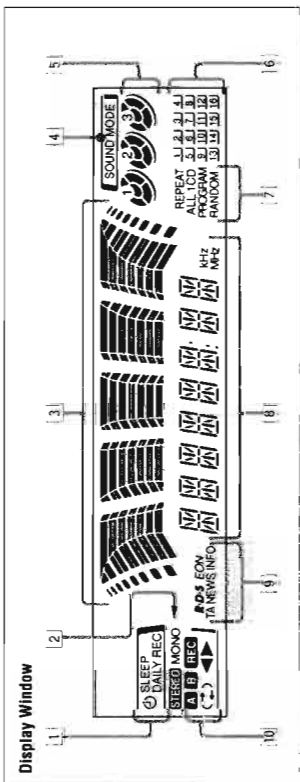

See pages in the parentheses for details.

Front Panel

- 1 Disc trays
- 2 CVI (standby/on) button and STANDBY lamp (9)
- 3 Display window
- 4 Remote sensor
- 5 PANEL OPEN/CLOSE button (9)
- 6 PHONE jack (10)
- 7 TAPE \blacktriangleleft button and lamp (18)
- 8 AUX button and lamp (9)
- 9 Deck A cassette holder (18)
- 10 EJECT button for deck A (18)
- 11 CD tray open/close buttons (15)
- 12 Disc number buttons and lamps (CD 1, CD 2, and CD 3) (15)
- 13 Volume control (10)
- 14 CD \blacktriangleright II (play/pause) button and lamp (15)
- 15 FM/AM button and lamp (12)
- 16 Deck B cassette holder (19)
- 17 EJECT button for deck B (19)
- 18 DECK A/B button (18)
- 19 TIMER/CLOCK button (9, 22)
- 20 SET button (9, 22)
- 21 SEA CONTROL button (11)
- 22 (stop) button (15, 18)
- 23 TUNING $-/+$ buttons (12)
- 24 \blacktriangleleft / \blacktriangleright (fast left/fast right) buttons (11, 16, 18)
- 25 DISPLAY button (9)
- 26 PROGRAM/RANDOM button (16, 17, 20)
- 27 EDIT button (21)
- 28 S. A. BASS (Signal Adaptive Bass) button and lamp (10)
- 29 SOUND MODE button (10)
- 30 CANCEL button (9, 17, 22)
- 31 DEMO button (8)
- 32 RDS operation buttons (13)
- 33 DISPLAY MODE, PTY/EON, and SELECT $-/+$ buttons

Pressing one of these buttons also turns on the unit.

- 11 Timer indicators
- 12 SLEEP REC. and DAILY indicators
- 13 Tuner operation indicators
- 14 STEREO and MONO indicators
- 15 Audio level indicator
- 16 SEA (Sound Effect Amplifier) pattern indicator
- 17 SOUND MODE indicator
- 18 Disc indicators
- 19 CD track number indicators
- 20 CD play mode indicators
- 21 REPEAT (ALL/CD/1), PROGRAM, and RANDOM indicators
- 22 Main display
- 23 Shows the source name, frequency, etc.
- 24 RDS operation indicators
- 25 RDS, EON, and TA/NEWS/INFO indicators
- 26 Tape operation indicators
- 27 A/B (operating deck), REV , C (reverse mode), and \blacktriangleleft \blacktriangleright (tape direction) indicators

Powered Rolling Panel

- 18 REVERSE MODE button (18, 20, 21)
- 19 REC START/STOP button (19, 21)
- 20 DUBBING button (20)
- 21 CD REC START button (20, 21)

Remote Control

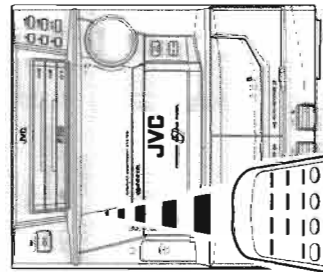
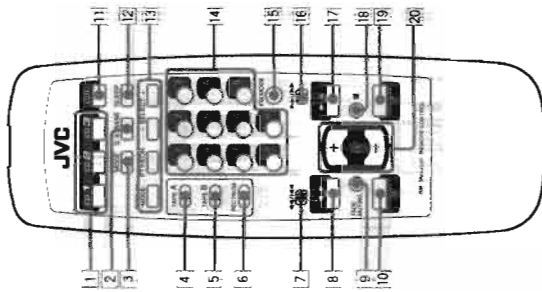

When using the remote control, point it at the remote sensor on the front panel.

Remote Control

- 1 Disc number buttons (CD 1, CD 2, and CD 3) (15)
- 2 S. A. BASS (Signal Adaptive Bass) button (10)
- 3 SOUND MODE button (10)
- 4 TAPE A button (18)
- 5 TAPE B button (18)
- 6 REC PAUSE button (19)
- 7 \blacktriangleleft / \blacktriangleright (fast left/reverse search) button (16 - 18)
- 8 TAPE \blacktriangleleft button (18)
- 9 Pressing this button also turns on the unit.
- 10 FADE MUTING button (10)
- 11 AUX button (9)
- 12 Pressing this button also turns on the unit.
- 13 CVI (standby/on) button (9)
- 14 SLEEP button (24)
- 15 RDS operation buttons (13)
- 16 DISPLAY MODE, PTY/EON, and SELECT $-/+$ buttons
- 17 Number buttons (12, 16)
- 18 FM MODE button (12)
- 19 \blacktriangleleft / \blacktriangleright (forward search/fast right) button (16 - 18)
- 20 CD \blacktriangleright II button (15)
- 21 Pressing this button also turns on the unit.
- 22 (stop) button (15, 18)
- 23 FM/AM button (12)
- 24 Pressing this button also turns on the unit.
- 25 VOLUME $+/-$ button (10)

Getting Started

English
English

Continued

Unpacking

After unpacking, check to be sure that you have all the following items.
The number in the parentheses indicates the quantity of the pieces supplied.

- AM loop antenna (1)
- FM antenna (1)
- Remote control (1)
- Batteries (2)

If any is missing, consult your dealer immediately.

Putting the Batteries into the Remote Control

Insert the batteries — R6P(SUM-3)/AA(15F) — into the remote control, by matching the polarity (+ and -) on the batteries with the + and - markings on the battery compartment.

When the remote control can no longer operate the unit, replace both batteries at the same time.

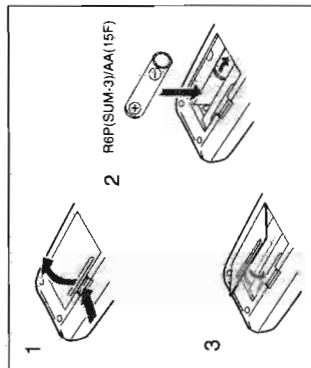

- DO NOT use an old battery together with a new one.
- DO NOT use different types of batteries together.
- DO NOT expose batteries to heat or flame.
- DO NOT leave the batteries in the battery compartment when you are not going to use the remote control for an extended period of time. Otherwise, it will be damaged from battery leakage.

Connecting Antennas

FM antenna

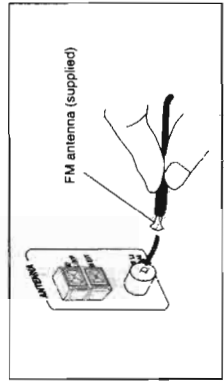

- 1 Attach the FM antenna to the FM 75 Ω COAXIAL terminal.
- 2 Extend the FM antenna.
- 3 Fasten it up in the position which gives you the best reception.



About the supplied FM antenna
The FM antenna supplied with this unit can be used as temporary measure. If reception is poor, you can connect an outdoor FM antenna.

To connect an outdoor FM antenna

Before connecting it, disconnect the supplied FM antenna.

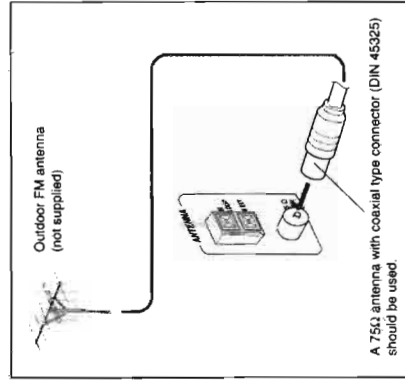

A 75Ω antenna with coaxial type connector (DIN 45325) should be used.

AM (MW/LW) antenna

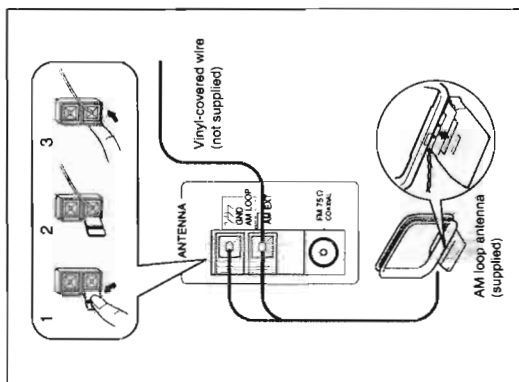

- 1 Connect the AM loop antenna to the AM LOOP terminals as illustrated.
- 2 Turn the AM loop antenna until you have the best reception.

To connect an outdoor AM antenna

When reception is poor, connect a single vinyl-covered wire to the AM EXT terminal and extend it horizontally. (The AM loop antenna must remain connected.)



For better reception of both FM and AM (MW/LW)
• Make sure the antenna conductors do not touch any other terminals and connecting cords.
• Keep the antennas away from metallic parts of the unit, connecting cords, and the AC power cord.

Connecting Speakers

You can connect a pair of front speakers, and one subwoofer.

To connect front speakers

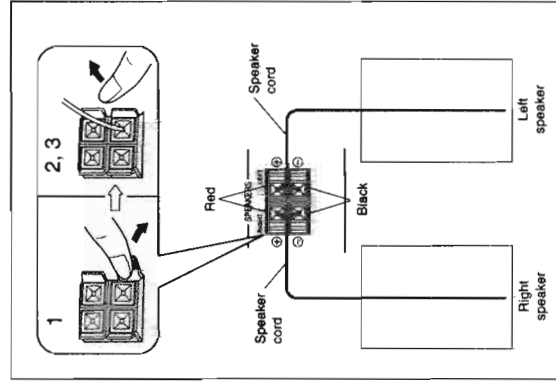

- 1 Press and hold the clamp of the speaker terminal on the rear of the unit.
- 2 Insert the end of the speaker cord into the terminal.
Match the polarity of the speaker terminals: Red (+) to red (+) and black (-) to black (-).
- 3 Release the finger from the clamp.

IMPORTANT: Use only speakers with the same speaker impedance as indicated by the speaker terminals on the rear of the unit.

Common Operations

Setting the Clock

Before operating the unit any further, first set the clock built in this unit.

1 Press PANEL, OPEN/CLOSE.
The unit is turned on and the Powered Rolling Panel opens automatically.

2 Press TIMER/CLOCK.
The hour digits start flashing on the display.

3 Press ← or → to adjust the hour, then press SET.
If you want to correct the hour after pressing SET, press CANCEL. The hour digits start flashing again.

4 Press ← or → to adjust the minute, then press SET.
CLOCK: 0K
Press DISPLAY while playing any source. Each time you press the button, the source indication and the clock time alternate on the display.

To adjust the clock again
If you have adjusted the clock before, you need to press TIMER/CLOCK repeatedly until the clock setting mode is selected.
Each time you press the button, the timer/clock setting modes change as follows:
DAILY → ON TIME → REC → Canceled → Clock setting (The hour digits start flashing)

If there is a power failure
The clock loses the setting and is reset to "0:00." You need to set the clock again.

To connect audio equipment with an optical digital input terminal
You can record CD sound onto the connected digital equipment.

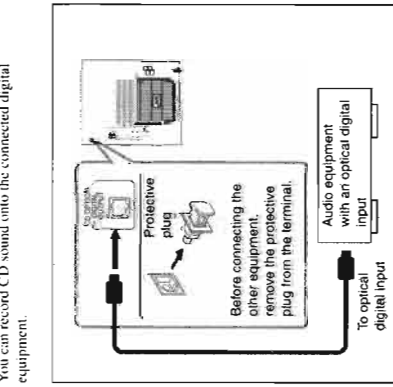

Connect an optical digital cord (not supplied) between the optical digital input terminal on the other equipment and the CD OPTICAL DIGITAL OUTPUT terminal.

NOW, you can plug in the unit and other connected equipment FINALLY!

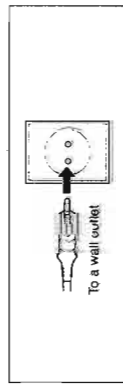

When connecting the AC power cord into a wall outlet, the unit automatically starts display demonstration.

To stop the display demonstration, press any button on the unit or the remote control.

To start the display demonstration manually
Press and hold DEMO for more than 2 seconds.

To stop the demonstration, press any button.

To connect a subwoofer
By connecting a subwoofer, you can enhance the bass.

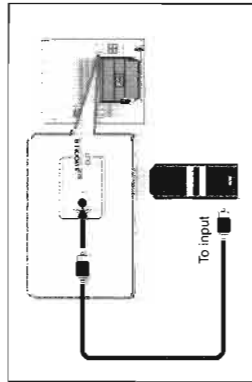

Connect the input jack of a powered subwoofer to the SUB WOOFER OUT jack, using a monoaural audio cord (not supplied).

Connecting Other Equipment

You can connect with analog and digital equipment.

- **DO NOT** connect any equipment while the power is on.
- **DO NOT** plug in any equipment until all connections are complete.

To connect an analog component

Be sure to connect audio cords correctly. White plugs are for left audio signals, and red ones for right audio signals.

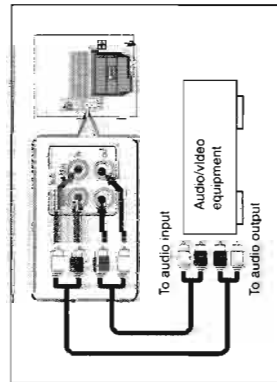

- By using audio cords (not supplied), connect:
- Between the audio input jacks on the other equipment and AUX OUT jacks: For recording on the other equipment.
 - Between the audio output jacks on the other equipment and AUX IN jacks: For playing the other equipment.

Turning On the Power and Selecting the Sources

When you press the play button for a particular source (FM/AM, CD ▶/III, AUX, and TAPE ◀▶), the unit turns on, and the Powered Rolling Panel opens automatically (and the unit starts playing the source if it is ready — COMPACT PLAY CONTROL).

To listen to the FM/AM (MW/LW) broadcasts, press FM/AM. (See pages 12 — 14.)
To play back CDs, press CD ▶/III. (See pages 15 — 17.)
To play back tapes, press TAPE ◀▶. (See page 18.)
To select the external equipment as the source, press AUX.

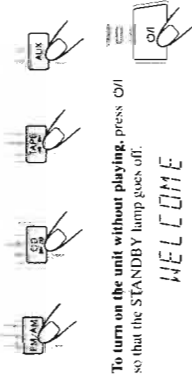

To turn on the unit without playing, press On/Off so that the STANDBY lamp goes off.

The Powered Rolling Panel opens automatically.

To turn off the unit (on standby), press On/Off again so that the STANDBY lamp lights up. The Powered Rolling Panel also closes. A little power is always consumed even while the unit is on standby.

To switch off the power supply completely, unplug the AC power cord from the AC outlet.

When you unplug the AC power cord or if a power failure occurs, the clock is reset to "0:00" right away, while the tuner preset stations (see page 12) will be erased in a few days.

Continued

Adjusting the Volume

You can adjust the volume level only while the unit is turned on.

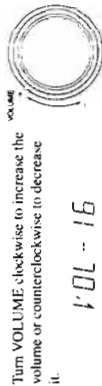

When using the remote control, press VOLUME + to increase the volume or press VOLUME - to decrease it.



For private listening
Connect a pair of headphones to the PHONES jack. No sound comes out of the speakers. Be sure to turn down the volume before connecting or putting on headphones.

DO NOT turn off (on standby) the unit with the volume set to an extremely high level; otherwise, a sudden blast of sound can damage your hearing, speakers and/or headphones when you turn on the unit or start playing any source next time. **REMEMBER** you cannot adjust the volume level while the unit is on standby.

To turn down the volume level temporarily
Press FADE MUTING on the remote control.

The volume level gradually decreases to "0".

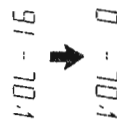

To restore the sound, press the button again.

Reinforcing the Bass Sound

The Signal Adaptive Bass function provided for this unit can enhance the bass sound while listening to any source at low volume. You can use this function only for playback.

To turn on the function, press S. A. BASS repeatedly until "SA-BASS1" or "SA-BASS2" appears on the display.



The S. A. BASS lamp (the button itself) also lights up.

- Each time you press the button, the Signal Adaptive Bass level applied to the playback sound changes as follows:

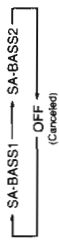

When you select "SA-BASS2," the bass sound level is enhanced much more than when you select "SA-BASS1."

- While playing back some sources, the level difference between "SA-BASS1" and "SA-BASS2" may not be distinct.

To turn off the function, press the button repeatedly until "OFF" appears on the display.

If you want to check the Signal Adaptive Bass level currently selected
While the S. A. BASS lamp is lit, press S. A. BASS once so that the current level appears for a while.

Selecting the Sound Modes

You can select one of the 6 preset sound modes (3 surround modes and 3 SEA - Sound Effect Amplifier - modes). The sound modes can be applied only to playback sounds, and cannot be used for recording.

To select the sound modes, press SOUND MODE until the sound mode you want appears on the display. The SOUND MODE indicator also lights up on the display.

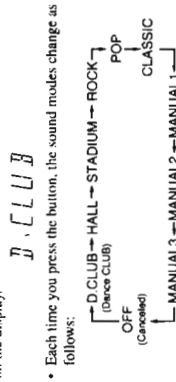

Each time you press the button, the sound modes change as follows:

2 Adjust the SEA pattern.

- Press ← or → to select the frequency range to adjust (LOW, MID, HIGH).
- Press ← or → to adjust the level (-3 to +3) of the selected frequency range.
- Repeat steps 1) and 2) to adjust the level of the other frequency ranges.

3 Press SEA CONTROL again.



- Press ← or → to select one of the MANUAL 1, 2, and 3 modes into which you want to store the SEA pattern.

5 Press SEA CONTROL again.



The SOUND MODE indicator also lights up. The SEA pattern you have created are stored into the MANUAL mode selected in the above step.

To use your own sound mode

Select MANUAL 1, 2, or 3 mode when using the sound modes. See "Selecting the Sound Modes" on page 10.

Surround modes *:
D.CLUB: Increases resonance and bass.
HALL: Adds depth and brilliance to the sound.
STADIUM: Adds clarity and spreads the sound, like in an outdoor stadium.

SEA modes:
ROCK: Boosts low and high frequency. Good for acoustic music.
POP: Good for vocal music.
CLASSIC: Good for classical music.

Manual modes:
MANUAL1/2/3: Your individual mode stored in memory. See "Creating Your Own Sound Mode - Manual Mode."

OFF:
Cancels the sound mode.
Surround elements are added to the SEA elements to create a being-there feeling in your room. When one of these modes is selected, the SOUND MODE indicator lights up as — **SOUND MODE**

While one of the SEA modes including manual modes (SEA elements without surround elements) is selected, it lights up as — **SOUND MODE**

Creating Your Own Sound Mode — Manual Mode

You can change SEA pattern to suit your preference. These changed settings can be stored in the MANUAL 1, 2, and 3 modes.

There is a time limit in doing the following steps. If the setting is canceled before you finish, start from step 1 again.

- If you want to add the surround elements in your SEA pattern, select one of the surround modes (D.CLUB, HALL, or STADIUM) before starting the procedure below.

On the unit ONLY:

- Press and hold SEA CONTROL until "SEA CONT" appears on the display.

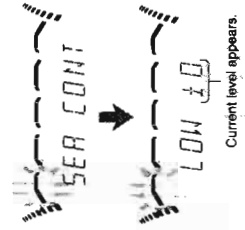

Listening to FM and AM (MW/LW) Broadcasts

English
English

Tuning in a Station

On the unit ONLY:

1 Press FM/AM.

The unit automatically turns on and tunes in the previously tuned station (either FM or AM - MW/LW). The Powered Rolling Panel automatically opens.

Each time you press the button, the band alternates between FM and AM (MW/LW).

2 Press and hold TUNING -/+ for more than 1 second.

The unit starts searching for stations and stops when a station of sufficient signal strength is tuned in. If a program is broadcast in stereo, the STEREO indicator lights up.

To stop during searching, press TUNING -/+.



When you press TUNING -/+ briefly and repeatedly the frequency changes step by step.

To change the FM reception mode

When an FM stereo broadcast is hard to receive or noisy, press FM MODE on the remote control so that the MONO indicator lights up on the display. Reception improves.

To restore the stereo effect, press FM MODE again so that the MONO indicator goes off. In this stereo mode, you can hear stereo sounds when a program is broadcast in stereo.

Presetting Stations

You can preset 30 FM and 15 AM (MW/LW) stations. In some cases, test frequencies have been already memorized for the tuner since the factory examined the tuner preset function before shipment. This is not a malfunction. You can preset the stations you want into memory by following the presetting method.

There is a time limit in doing the following steps. If the setting is canceled before you finish, start from step 1 again.

1 Tune in the station you want to preset.

See "Tuning in a Station" above.

FM 87.50

2 Press SET.

SET

3 Press PRESET -/+ to select a preset number.

P-1

4 Press SET again.

STORE

The tuned station in step 1 is stored in the preset number selected in step 3.

Storing a new station on a used number erases the previously stored one.

When you unplug the AC power cord or if a power failure occurs the preset stations will be erased in a few days. If this happens, preset the stations again.

Tuning in a Preset Station

1 Press FM/AM.

The unit automatically turns on and tunes in the previously tuned station (either FM or AM - MW/LW). The Powered Rolling Panel automatically opens.

Each time you press the button, the band alternates between FM and AM (MW/LW).

2 Select a preset number.

On the unit: Press PRESET -/+.

On the remote control: Press the number buttons.

For preset number 5, press 5. For preset number 15, press +10 then 5.

For preset number 20, press +10, then 10.

For preset number 25, press +10, +10, then 5.

Receiving FM Stations with RDS

RDS allows FM stations to send an additional signal along with their regular program signals. For example, the stations send their station names, as well as information about what type of program they broadcast, such as sports or music, etc.

When tuned to an FM station which provides the RDS service, the RDS indicator lights up on the display.

With the unit, you can receive the following types of RDS signals.

PS (Program Service): Shows commonly known station names.

PTY (Program Type): Shows types of broadcast programs.

RT (Radio Text): Shows text messages the station sends.

EON (Enhanced Other Networks): Provides the information about the types of the programs sent by other RDS stations.



More about RDS
Some FM stations and AM (MW/LW) stations do not provide RDS signals.
RDS services vary among FM RDS stations. For details on RDS services in your area, check with local radio stations.
RDS may not work correctly if the received station is not transmitting the signals properly or if the signal strength is weak.

Changing the RDS Information

You can see RDS information on the display while listening to an FM station.

Press DISPLAY MODE.

Each time you press the button, the display changes to show the following information:

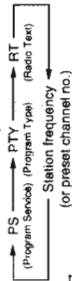

(or preset channel no.)

If no PS, PT, or RT signals are sent by a station "NO PS," "NO PT," or "NO RT" appears in the main display.



If the unit takes time to show the RDS information received from a station "WAIT PS," "WAIT PT," or "WAIT RT" may appear on the display.

Searching for Programs by PT Codes (PTY Search)

One of the advantages of RDS is that you can locate a particular kind of program by specifying the PT codes.

- For details on the PT codes, see "Additional Information" on page 25.

To search for a program using the PT codes REMEMBER you must preset FM RDS stations to use the EON function. If not yet done, see page 12.

There is a time limit in doing the following steps. If the setting is canceled before you finish, start from step 1 again.

1 Press PTY/EON until "PTY" and "SELECT" alternately appears on the display.

Each time you press the button, RDS operation mode changes as follows:

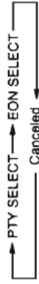

2 Press SELECT -/+ until the PTY code you want appears on the display.

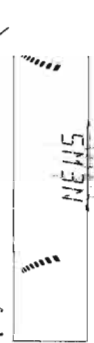

Each time you press the button, the PTY codes change as follows:

- NEWS
- EDUCATE
- SCIENCE
- M.O.R.M.
- OTHER M.
- CHILDREN
- COUNTRY
- FOLK M.
- NEWS
- INFO
- VARIED
- WEATHER
- SOCIAL A.
- TRAVEL
- NATIONAL
- DOCUMENT
- SPORT
- CULTURE
- POP M.
- CLASSICS
- FINANCE
- RELIGION
- LEISURE
- JAZZ
- TRAFFIC

3 Press PTY/EON once again.

While searching, "SEARCH" and the selected PTY code alternate on the display.

The unit searches 30 preset FM stations. Steps when it finds the one you have selected ("FOUND" appears), and tunes in that station.

If no program is found, "NOT" and "FOUND" alternately appears on the display and the unit returns to the last received station.

To stop searching any time during the process Press PTY/EON while searching.

Playing Back CDs

Loading CDs

- 1 Press **▲** for the disc tray (CD 1 to 3) you want to load a CD onto. The unit automatically turns on and the disc tray comes out. The Powered Rolling Panel also opens automatically.
- 2 Place a disc correctly on the circle of the disc tray, with its label side up.

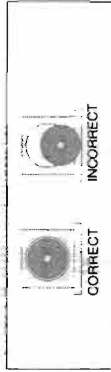

When using a CD single (8 cm), place it on the inner circle of the disc tray.

- 3 Press the same **▲** you have pressed in step 1. The disc tray closes, and the corresponding disc number indicator (CD 1 to CD 3) lights up on the display.



- 4 Repeat steps 1 to 3 to place other CDs.

Notes When loading more than one CD continuously When you press **▲** for the next tray you want to place another CD onto, the first disc tray automatically closes and then the next tray comes out.

Notes About the disc indicators Each disc indicator corresponds to the disc tray of the same number.



The disc marker lights up for the disc number you have selected. The disc indicator flashes while the corresponding CD is being played. The disc indicator goes off when the unit has detected that there is no CD on the corresponding disc tray.

Switching to a Program Type of Your Choice Temporarily

By receiving EON data sent by FM RDS stations, the EON function allows the unit to switch temporarily to a broadcast program of your choice (TA, NEWS, and INFO) from a different station. The EON function only works when you are listening to a preset FM RDS station providing EON data.

- The EON indicator lights while receiving a station with EON data.

To activate the EON function

REMEMBER you must preset FM RDS stations to use the EON function. If not yet done, see page 12.

- There is a time limit in doing the following steps. If the setting is canceled before you finish, start from step 1 again.

- 1 Press PTY/EON until "EON" and "SELECT" alternately appear on the display.
 - Each time you press the button, RDS operation mode changes as follows:

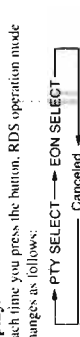

- 2 Press SELECT - / + until the EON data type you want appears on the display. The selected EON data type indicator also flashes.



TA: Traffic announcement
NEWS: News
INFO: Program the purpose of which is to impart advice in the widest sense.

OFF: The EON function is canceled. The EON data type indicator (TA, NEWS, INFO) goes off.

- 3 Press PTY/EON once again. The EON data type indicator stops flashing and remains lit. Now, the EON function is activated. See "How the EON function actually works."

How the EON function actually works:

CASE 1

If there is no station broadcasting the program you have selected The unit continues tuning in the current station.

When a station starts broadcasting the program you have selected, the unit automatically switches to the station. The indicator of received PTY code starts flashing.

When the program is over, "EON END" appears in the main display, and the unit goes back to the previously tuned station, but the EON function still remains activated.

CASE 2

If there is a station broadcasting the program you have selected The unit tunes in the program. The indicator of received PTY code starts flashing.

When the program is over, "EON END" appears in the main display, and the unit goes back to the previously tuned station, but the EON function still remains activated.

CASE 3

If the FM station you are listening to is broadcasting the program you have selected The unit continues to receive the station but the indicator of received PTY code starts flashing.

When the program is over, the indicator of received PTY code stops flashing and remains lit, but the EON function still remains activated.

Notes

More about the EON function
EON data sent from some stations may not be compatible with this unit. In this case, the EON function may not work correctly. While listening to a program tuned in by the EON function, the station does not change even if another network station starts broadcasting a program of the same EON data.
The EON function is canceled when you change the source to CD, TAPE, or AUX, while it is temporarily canceled when you change the source to AM.

Playing Back the Entire Discs — Continuous Play

You can play CDs continuously.

- 1 Load CDs.
- 2 Press one of the disc number buttons (CD 1, CD 2, and CD 3) for the disc you want to play. CD play starts from the first track of the selected disc.

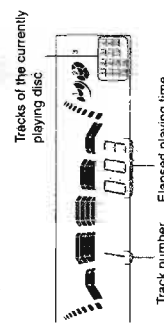

Track number Elapsed playing time
Pressing CD **▶/||** instead of the disc number buttons starts playing back if a CD is on the trays.

To stop during play, press **■**.
To remove the disc, press **▲** for the corresponding disc tray.

Notes

CD playback sequence
When 3 CDs are loaded on the disc trays, they are played in one of the following sequences.
• When CD 1 is pressed: CD 1 → CD 2 → CD 3 (then stops)
• When CD 2 is pressed: CD 2 → CD 3 → CD 1 (then stops)
• When CD 3 is pressed: CD 3 → CD 1 → CD 2 (then stops)
• When only 2 CDs are loaded, they are played in the same order, but the disc tray without a CD is skipped.

Basic CD Operations

While playing a CD, you can do the following operations.

To exchange CDs during playback of another
Press **▲** corresponding to a CD, not playing or selected currently, to eject and exchange the CD.
If you exchange CDs during play, the current play will not stop until all CDs you have exchanged are played.

To stop play for a moment
Press CD **▶/||**.

While pausing, the elapsed playing time flashes on the display.

To resume play, press CD **▶/||** again.

Continued

To locate a particular point in a track
During play, press and hold or .
• : Fast reverses the disc.
• : Fast forwards the disc.
When using the remote control, press and hold or .

To go to another track
Press or repeatedly before or during playback.
• : Goes back to the beginning of the current or previous tracks.
• : Skips to the beginning of the next or succeeding tracks.
When using the remote control, press or or or before playing.

If you press and hold or (or or) before playing
You can change the tracks continuously.

To go to another track directly using the number buttons
Pressing the number button(s) before or during play allows you to start playing the track number you want.
Ex.: For track number 5, press 5.
For track number 15, press +10, then 5.
For track number 20, press +10, then 10.
For track number 32, press +10, +10, +10, then 2.



• Each time you press the button, CD play mode changes as follows:
 → Continuous Play → Random Play

3 Press one of the disc number buttons (CD 1, CD 2, and CD 3) to select the disc number you want to play.
Track number
Disc number
Program step number

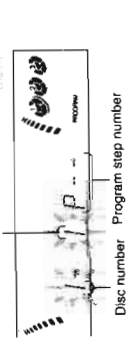

4 Select a track from the CD selected in the above step.
On the unit:
Press or to select the track number, then press SET.

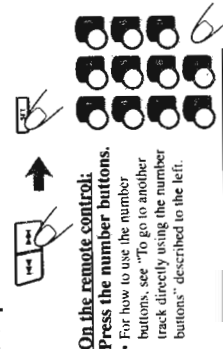

On the remote control:
Press the number buttons.
• For how to use the number buttons, see "To go to another track directly using the number buttons," described to the left.



5 Program other tracks you want.
• To program tracks from the same disc, repeat step 4.
• To program tracks from a different disc, repeat steps 3 and 4.

6 Press CD > III.
The tracks are played in the order you have programmed.

To stop during play, press .
To exit from Program play mode, press PROGRAM/RANDOM repeatedly again before or after play so that the unit enters another play mode. (The program you have made is stored in memory until you turn off the unit or erase the program.)

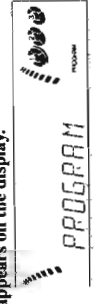

• If a program has been stored in memory, the program is called up.

To check the program contents
Before playing, you can check the program contents by pressing or on the remote control.
• or : Shows the programmed tracks in the programmed order.
• or : Shows them in the reverse order.

To modify the program
Before play, you can erase the programmed tracks shown on the display by pressing CANCEL.
• Each time you press the button, the programmed track shown on the display is erased from the program.

To add tracks in the program before play, simply select the track numbers you want to add by following step 4 of the programming procedure on page 16.
To erase the entire program before or after play, press .
"PROGRAM" appears on the display.
• Ejecting a CD will also erase the track numbers programmed from the ejected CD.

If you try to program a 33rd step
"FULL" will appear on the display.

If your entry is ignored
You have tried to program a track from an empty tray, or a track number that does not exist on the CD (for example, selecting track 14 on a CD that only has 12 tracks). Such entries are ignored.

Playing at Random — Random Play
The tracks of all loaded CDs will play at random.
• To use Repeat play for Random play, press REPEAT after starting Random play.

1 Prepare CDs.
• If the current playing source is not the CD player, press CD > III, then before going to the next step.

2 Press PROGRAM/RANDOM repeatedly until "RANDOM" appears on the display.

• Each time you press the button, CD play mode changes as follows:
 → Continuous Play → Random Play

3 Press CD > III.
The tracks are played at random.
Random play ends when all the tracks are played once.

To stop during play, press .
• Random play also stops when one of the disc trays is opened.

To exit from Random play mode, press PROGRAM/RANDOM repeatedly again before or after play so that the unit enters another play mode.

Even if you press (or) on the remote control
You cannot go back to the previous tracks during Random play.
• If you press (or) on the remote control, you can go to next random tracks.

Repeating Tracks or CDs — Repeat Play
You can have all the CDs, the program or the individual track currently playing repeat as many times as you like.

To repeat play, press REPEAT during or before playing. To use Repeat play for Program play and Random play, press the button after starting playback.
• Each time you press the button, Repeat play mode changes as follows, and the following indicator lights up on the display:
 → REPEAT ALL → REPEAT 1 (Continuous play)
 → REPEAT 1 → REPEAT 1

REPEAT ALL: Repeats all the tracks on all the CDs (continuously or at random), or all the tracks in the program.
REPEAT 1CD: Repeats all the tracks on one CD.
REPEAT 1: Repeats one track on one CD.
• REPEAT 1CD is not used for Program play and Random play.

To cancel repeat play, press REPEAT repeatedly until the REPEAT indicator (REPEAT ALL, REPEAT 1CD, or REPEAT 1) goes off from the display.
• Repeat play is also canceled when you select Program play or Random play.

Prohibiting Disc Ejection — Tray Lock
You can prohibit CD ejection from the unit and can lock discs.
• This operation is possible only using the buttons on the unit.

To prohibit disc ejection, press . For any disc tray while holding . (If there is any disc tray opened, close it first.)
"LOCKED" appears for a while, and the loaded CDs are locked.

To cancel the prohibition and unlock the CDs, press . For any disc tray while holding .
"UNLOCKED" appears for a while, and the loaded CDs are unlocked.

If you try to eject CDs
"LOCKED" appears to inform you that the Tray Lock is in use.

Playing Back Tapes

You can play back type I, type II, and type IV tapes without changing any settings.

Playing Back a Tape

1 Press EJECT (▲) for the deck you want to use.

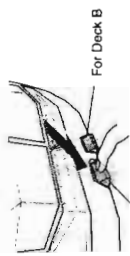

For Deck A

2 Put a cassette in, with the exposed part of the tape down.



3 Close the cassette holder gently.

If you put cassettes in both decks A and B, the last deck you have put a cassette into is selected. To operate the other deck, press DECK A/B (or TAPE A or TAPE B) on the remote control.

4 Press TAPE ◀▶.

The tape play starts and the tape direction indicator (▶▶) starts flashing slowly to indicate the tape running direction.

- Each time you press the button, the tape direction changes.
 - ▶▶: plays the front side.
 - ◀◀: plays the reverse side.

When the tape plays to the end, the deck automatically stops if the Reverse Mode is not on. (See "To play both sides repeatedly" — Reverse Mode.)

To stop during play, press ■.

To operate the other deck, press DECK A/B (or TAPE A or TAPE B) on the remote control, then TAPE ◀▶.

To fast wind to the left or to the right, press ◀◀/▶▶ (◀◀/▶▶ or ▶▶/◀◀) on the remote control while the tape is not running.

The tape direction indicator (▶▶) starts flashing quickly on the display.

To remove the cassette, press ▲ EJECT for deck A or EJECT ▲ for deck B.

Recording

IMPORTANT:

- It may be unlawful to record or play back copyrighted material without the consent of the copyright owner.
- The recording level is automatically set correctly, so it is not affected by the VOLUME control. Thus, during recording you can adjust the sound you are actually listening to without affecting the recording level.
- While recording, you can hear sound modes and/or the Signal Adaptive Bass effect through the speakers or headphones. However, the sound is recorded without these effects (see page 10).
- If recordings you have made have excessive noise or static, the unit may be too close to a TV. Increase the distance between the TV and the unit.
- You can use type I and II tapes for recording.

To protect your recording

Cassettes have two small tabs on the back to protect unexpected erasure or re-recording.

To protect your recording, remove these tabs.

To re-record on a protected

tape, cover the holes with

adhesive tape.

When using type II tape, be

careful not to cover the holes

used to detect the tape type.



To keep the best recording and playback sound quality

If the heads, capstans, and pinch rollers of the cassette decks become dirty, the following will occur:

- Impaired sound quality
- Discontinuous sound
- Fading
- Incomplete erasure
- Difficulty in recording

To clean the heads, capstans, and pinch rollers

Use a cotton swab moistened with alcohol.

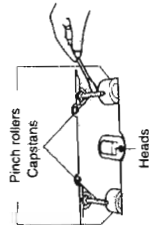

To demagnetize the heads

Turn off the unit, and use a head demagnetizer (available at electronics and record shops).

Recording Tapes on Deck B

1 Press EJECT ▲ for the deck B.

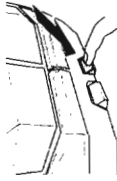

2 Put in a recordable cassette, with the exposed part of the tape down.

3 Close the cassette holder gently.

4 Check the tape direction of deck B.

- If the tape direction is not correct, press TAPE ◀▶ twice then ■ to change the tape direction.

5 Start playing the source — FM, AM*, CD player, deck A, or auxiliary equipment connected to AUX jacks.

- When the source is CD, you can also use CD Direct Recording (see page 20) and Auto Edit Recording (see page 21).

- When the source is deck A, you can also use the dubbing method. (See "Dubbing Tapes" on page 20.)
- See "To record an AM (MW/LW) station - Beat Cut" on page 20.

6 Start recording.

On the unit:
Press REC START/STOP.

The REC indicator lights up on the display and recording starts.

On the remote control:

1) Press REC PAUSE.

The REC indicator starts flashing on the display.

2) Press TAPE ◀▶.

The REC indicator stops flashing and remains lit, and recording starts.

To stop during recording, press REC START/STOP again (or ■ on the remote control).

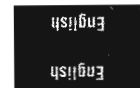

To play both sides repeatedly — Reverse Mode

Reverse Mode works for both decks at the same time. When it is in use, the tape automatically reverses at the end of a side and the unit starts playing the other side of the tape, and repeats the same process.

To use Reverse Mode, press REVERSE MODE so that the Reverse Mode indicator on the display lights up like — (◀▶).

To cancel Reverse Mode, press the button again so that the Reverse Mode indicator on the display lights up like — (▶▶).

When Reverse Mode is on with cassettes in both decks A and B

After the reverse (◀) side of the tape finishes playing, the tape in the other deck starts playing.

Locating the Beginning of a Song — Music Scan

You can use Music Scan to locate the beginning of a song. Music Scan searches for blank portions that usually separate recorded songs, then plays the next song.

To find the beginning of the current song

During play, press ◀▶/▶▶ (◀▶/▶▶ or ▶▶/◀▶) on the remote control in the opposite direction to the tape play.

The tape direction indicator of the opposite direction to the tape play starts flashing slowly and quickly alternately.

Searching stops automatically at the beginning of the current song, and the current song starts automatically.

To find the beginning of the next song

During play, press ◀▶/▶▶ (◀▶/▶▶ or ▶▶/◀▶) on the remote control in the same direction as the tape play. The tape direction indicator of the same direction as the tape play starts flashing slowly and quickly alternately.

Searching stops automatically at the beginning of the next song, and the next song starts automatically.

Music Scan works by detecting a 4-second long blank between each song, so it will not work well in the following cases

- No blank at the beginning of a song.
- Noise (often caused by much use or poor quality dubbing) which fills the blank.
- Long, very soft passages or pauses in a song.

The use of the C-120 or thinner tape is not recommended since characteristic deterioration may occur and this tape easily jams in the pinch-rollers and the capstans.

Continued

CD Direct Recording

Everything on the CD goes onto the tape in the order it is on the CD, or according to the order you have made for Program play.

- 1 Put a recordable cassette into deck B.
- 2 Place a disc correctly on the circle of the disc tray, with its label side up.
- 3 Press one of the disc number buttons (CD 1 to CD 3) to select the disc, then ■.
- 4 Press CD REC START. "CD REC" appears, and the  indicator lights up on the display. Deck B starts recording and the CD player starts playing. When the recording is done, "CD REC FINISHED" appears on the display, and the CD player and deck B stop.

To stop during CD Direct Recording, press ■.

To remove the cassette, press EJECT  for deck B.

To record on both sides — Reverse Mode Press REVERSE MODE so that the Reverse Mode indicator lights up as —  —.

When using the Reverse Mode for CD Direct Recording, start recording in the forward (▶) direction first. When the tape reaches its end while recording a song in the forward direction (▶), the last song will be recorded at the beginning of the reverse side (◀).

If you start recording on the reverse side (◀), recording will stop when recording is done only on one side (reverse) of the tape.

To cancel Reverse Mode, press the button again so that the Reverse Mode indicator lights up as —  —.

To stop recording temporarily (except when the playback source is deck A), press REC PAUSE on the remote control.

To resume recording, press TAPE ◀▶.

To remove the cassette, press EJECT  for deck B.

To record on both sides — Reverse Mode Press REVERSE MODE so that the Reverse Mode indicator lights up as —  —.

When using the Reverse Mode for recording, start recording in the forward (▶) direction first. Otherwise, recording will stop when recording is done only on one side (reverse) of the tape.

To cancel Reverse Mode, press the button again so that the Reverse Mode indicator lights up as —  —.



To record an AM (MW/LW) station — Beat Cut While recording an AM (MW/LW) broadcast, beats may be heard (which are never heard when listening to the broadcast without recording it). If this occurs, press PROGRAM/RANDOM repeatedly, while recording, until the beats are reduced.

Each time you press the button, the display changes to show the following:

 CUT1 → CUT2 → CUT3 → CUT4

Dubbing Tapes

It is preferable that the tape type (type I or II) you record from be the same as the tape type you record onto when dubbing tapes.

- 1 Press TAPE ◀▶, then ■.
 - 2 Put the source cassette in deck A, and a recordable cassette into deck B.
 - Put the cassettes in both decks so that the tapes will run in the forward (▶) direction.
 - 3 Press DUBBING. Dubbing starts. To stop during dubbing, press ■. To remove the cassette, press  EJECT for deck B.
- To record on both sides — Reverse Mode Press REVERSE MODE so that the Reverse Mode indicator lights up as —  —.
- To cancel Reverse Mode, press the button again so that the Reverse Mode indicator lights up as —  —.

Auto Edit Recording

By using Auto Edit Recording, you can record the CD tracks to fit the tape. Auto Edit Recording makes a program by selecting the CD tracks in numerical order. However, to prevent the end of the last track on the front side from being cut off, the last track is selected so as to fit on the remaining tape length.

On the unit ONLY:

- 1 Place a disc correctly on the circle of the disc tray, with its label side up.
 - If the current playing source is not the CD player, press CD ▶ III, then ■ before going to the next step.

2 Press EDIT.  

- 3 Press the disc number button (CD 1 to CD 3) for the disc you want to record from. 

 TAPE L60

The optimum tape length for the disc appears.



To change the tape length manually If the tape length selected is not satisfactory, you can change the tape length by pressing ◀▶ or ▶▶. You can select the tape length among the following — 40, 46, 50, 54, 60, 64, 70, 74, 80, 84, and 90.

- 4 Press SET. 

Tracks to be recorded on the reverse side (SIDE-B) appear.

- Each time you press the button, the tracks to be recorded on the front side (SIDE-A) and on the reverse side (SIDE-B) alternate.

- 5 Put a recordable cassette of appropriate length into deck B.

- 6 Press REVERSE MODE so that the Reverse Mode indicator lights up as —  —. Without turning on the Reverse Mode (), recording will stop when the front side of the tape is recorded.

- 7 Press CD REC START. The  indicator lights up on the display. Deck B starts recording then, about 10-second later, the CD player starts playing. When the recording is done, "CD REC FINISHED" appears on the display, and the CD player and deck B stop.

- If a tape has not been rewound, deck B will rewind the tape before it starts recording.
- A 10-second blank portion is automatically created at the beginning of each side of the tape.

To stop during Auto Edit Recording

- Press ■ so that a 4-second blank portion is created on the recorded tape. (Remember a 4-second blank is important when using Music Scan — see page 18.)

OR

- Press REC START/STOP. No 4-second blank portion is created on the recorded tape.

To cancel Auto Edit Recording

- Press PROGRAM/RANDOM before or after play. (The unit enters Program, Random, or Continuous Play mode.)

OR

- Press  for the disc you have selected.

To remove the cassette, press EJECT  for deck B.

Using the Timers

There are three timers available — Recording Timer, Daily Timer, and Sleep Timer. Before using the timers, you need to set the clock built in the unit. (See page 9.)

Using Daily Timer

With Daily Timer, you can wake to your favorite music or radio program.

How Daily Timer actually works

The unit automatically turns on, sets the volume level to the preset level, and begins playing the specified source when the on-time comes (the indicator flashes just before the on-time, and continues flashing while the timer is operating). Then, when the off-time comes ("OFF" flashes just before the off-time), the unit automatically turns off (stands by). The timer setting remains in memory until you change it.

- There is a time limit in doing the following steps. If the setting is canceled before you finish, start from step 1 again.
- If you have made a mistake while setting timer, press CANCEL. (However, this does not always work. If CANCEL does not work, press TIMER/CLOCK repeatedly and start from step 1 again.)

On the unit ONLY:

1 Press TIMER/CLOCK until "DAILY" appears on the display.

The DAILY indicator also starts flashing on the display.

- Each time you press the button, the timer setting modes change as follows:

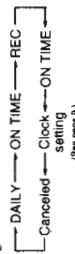

2 Press TIMER/CLOCK again.

"ON TIME" appears for 2 seconds, then the unit enters on-time setting mode.

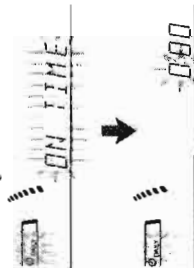

3 Set the on-time you want the unit to turn on.

1) Press or to set the hour, then press SET.

2) Press or to set the minute, then press SET.

"OFF TIME" appears for 2 seconds, then the unit enters off-time setting mode.

4 Set the off-time you want the unit to turn off (on standby).

1) Press or to set the hour, then press SET.

2) Press or to set the minute, then press SET.

The unit enters source selecting mode.



5 Press or to select the source to play, then press SET.

• Each time you press or , the source changes as follows:

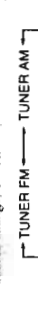

TUNER FM: tunes into a specified preset FM station. → go to step 6.

TUNER AM: tunes into a specified preset AM (MW/LW) station. → go to step 6.

- CD - -: plays a disc from a specified track of a specified disc. → go to step 6.

• Make sure there is a CD on the selected disc number tray.

TAPE: plays a tape in deck A or B. → go to step 7.

• Make sure that a tape is in the deck whose deck indicator (A or B) is lit on the display.

• Make sure that the tape direction is correct.

AUX: plays an external source. → go to step 7.

• To use this setting, the external component has to be equipped with the timer function.

English
English

Continued

6 When selecting "CD --" number, then press SET.

1) Press or to select the disc number, then press SET.

2) Press or to set the track number, then press SET.

The unit enters volume setting mode.

When selecting "TUNER FM" or "TUNER AM"

Press or to select the preset station number, then press SET.

The unit enters volume setting mode.

7 Press or to set the volume level.

• You can select the volume level from among four levels. If you select "VOL ---", the volume is set to the last level when the unit has been turned off.



8 Press SET to complete the Daily Timer setting.

The DAILY indicator stops flashing and remains lit. The settings you have done are shown on the display in sequence.

9 Press to turn off the unit (on standby) if you have set the Daily Timer with the unit turned on.

To turn on or off Daily Timer after its setting is done

1 Press TIMER/CLOCK repeatedly until "DAILY" appears on the display.

2 To turn off the Daily Timer, press CANCEL. The DAILY indicator goes off from the display. The Daily Timer is canceled, but the setting for the Daily Timer remains in memory.

To turn on the Daily Timer, press SET. The DAILY indicator lights up on the display. The settings you have done are shown on the display in sequence for your confirmation.

If the unit is turned on when the timer-on time comes Daily Timer does not work.

Notes

• Each time you press the button, the timer setting modes change as follows:

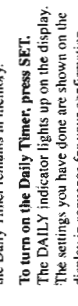

3 Press TIMER/CLOCK again.

"ON TIME" appears for 2 seconds, then the unit enters on-time setting mode.

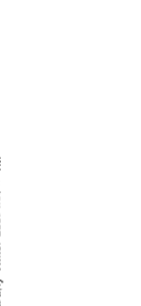

Using Recording Timer

With Recording Timer, you can make a tape of a radio broadcast automatically.

How Recording Timer actually works

The unit automatically turns on, tunes into the specified station, sets the volume level to "0," and starts recording when the on-time comes (the indicator flashes just before the on-time, and continues flashing while the timer is operating). Then, when the off-time comes ("OFF" appears just before the off-time), the unit automatically turns off (stands by). The timer setting remains in memory until you change it.

- There is a time limit in doing the following steps. If the setting is canceled before you finish, start from step 1 again.
- If you have made a mistake while setting the timer, press CANCEL. (However, this does not always work. If CANCEL does not work, press TIMER/CLOCK repeatedly and start from step 1 again.)

On the unit ONLY:

1 Put a recordable cassette into deck B.

2 Press TIMER/CLOCK until "REC" appears on the display.

The REC indicator also starts flashing on the display.

• Each time you press the button, the timer setting modes change as follows:

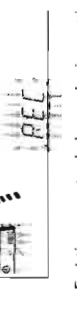

3 Press TIMER/CLOCK again.

"ON TIME" appears for 2 seconds, then the unit enters on-time setting mode.

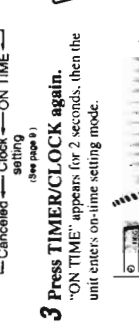



Additional Information

Description of the PTY codes:

NEWS:	News.	FINANCE:	Stock Market reports, commerce, trading etc.
AFFAIRS:	Topical program expanding or enlarging upon the news — debate, or analysis.	CHILDREN:	Programs targeted at a young audience.
INFO:	Program the purpose of which is to impart advice in the widest sense.	SOCIAL-A:	Programs about sociology, history, geography, psychology and society.
SPORT:	Program concerned with any aspect of sports.	RELIGION:	Religious programs.
EDUCATE:	Educational programs.	PHONE IN:	Involving members of the public expressing their views either by phone or at a public forum.
DRAMA:	All radio plays and serials.	TRAVEL:	Travel information.
CULTURE:	Programs concerning any aspect of national or regional culture, including language, theatre, etc.	LEISURE:	Programs about recreational activities.
SCIENCE:	Programs about natural sciences and technology.	JAZZ:	Jazz music.
VARIED:	Used for mainly speech-based programs like quizzes, panel games and personality interviews.	COUNTRY:	Songs which originate from, or continue the musical tradition of the American Southern States.
POP M:	Commercial music of current popular appeal.	NATIONAL:	Current popular music of the nation or region in that country's language.
ROCK M:	Rock music.	OLDIES:	Music from the so-called "golden age" of popular music.
M.O.R. M:	Current contemporary music considered to be "easy listening".	FOJ.K M:	Music which has its roots in the musical culture of a particular nation.
LIGHT M:	Instrumental music, and vocal or choral works, symphonies, chamber music, etc.	DOCUMENT:	Programs concerning factual matters, presented in an investigative style.
OTHER M:	Music not fitting into any of the other categories.	TRAFFIC:	Traffic announcement.
WEATHER:	Weather reports and forecasts.		

Classification of the PTY codes for some FM stations may be different from the above list.



Maintenance

To get the best performance of the unit, keep your discs, tapes, and mechanism clean.

Handling discs

- Remove the disc from its case by holding it at the edge while pressing the center hole lightly.
 - Do not touch the shiny surface of the disc, or bend the disc.
 - Put the disc back in its case after use to prevent warping.
 - Be careful not to scratch the surface of the disc, when placing it back in its case.
 - Avoid exposure to direct sunlight, temperature extremes, and moisture.
- To clean the disc**
Wipe the disc with a soft cloth in a straight line from center to edge.



Handling cassette tapes

- If the tape is loose in its cassette, take up the slack by inserting a pencil in one of the reels and raising it.
- If the tape is loose, it may get stretched, cut, or caught in the cassette.
- Be careful not to touch the tape surface.
- Avoid the following places to store the tape:
 - In dusty places
 - In direct sunlight or heat
 - In moist areas
 - Near a magnet

DO NOT use any solvent — such as conventional record cleaner, spray, thinner, or benzine — to clean the disc.

Using Sleep Timer

With Sleep Timer, you can fall asleep to music. You can set Sleep Timer when the unit is turned on.

How Sleep Timer actually works
The unit automatically turns off after the specified time length passes.

On the remote control ONLY:
1 Press SLEEP. The time length until the shut-off time appears and the SLEEP indicator starts flashing on the display.
* Each time you press the button, the time length changes as follows:

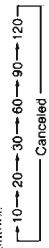

2 Wait for about 5 seconds after specifying the time length. The SLEEP indicator stops flashing and remains lit.

To check the remaining time until the shut-off time, press SLEEP once so that the remaining time until the shut-off time appears for about 5 seconds.

To change the shut-off time, press SLEEP repeatedly until the desired time length appears on the display.

To cancel the setting, press SLEEP repeatedly so that the SLEEP indicator goes off.
* Sleep Timer is also canceled when you turn off the unit.

Timer Priority

Since each timer can be set separately, you may wonder what happens if the settings for these timers overlaps. Here are examples.

- Recording Timer has priority over Daily Timer and Sleep Timer. If Daily Timer is set to come on while Recording Timer is operating, Daily Timer will not come on at all.

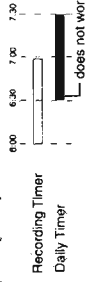

If Recording Timer is set to come on while Sleep Timer is operating, Sleep Timer will not work (the SLEEP indicator does not go off).

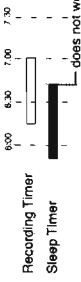

4 Set the on-time you want the unit to turn on.
1) Press [] or [] to set the hour, then press SET.
2) Press [] or [] to set the minute, then press SET.
"OFF TIME" appears for 2 seconds, then the unit enters off-time setting mode.

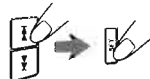

5 Set the off-time you want the unit to turn off (on standby).
1) Press [] or [] to set the hour, then press SET.
2) Press [] or [] to set the minute, then press SET.
The unit enters preset station selecting mode.



6 Select the preset station.
1) Press [] or [] to select the band ("TUNER FM" or "TUNER AM"), then press SET.
2) Press [] or [] to select a preset channel number, then press SET.
The REC indicator stops flashing and remains lit. The settings you have done are shown on the display in sequence.

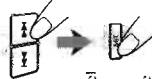

7 Press [] to turn off the unit (on standby) if necessary.



Notes
If you want to listen to another source while recording, without stopping it, you cannot change the source.

To turn on or off Recording Timer after its setting is done



1 Press TIMER/CLOCK repeatedly until "REC" appears on the display.
2 To turn off the Recording Timer, press CANCEL.

The REC indicator goes off from the display. The Recording Timer is canceled, but the setting for the Recording Timer remains in memory.

To turn on the Recording Timer, press SET. The REC indicator lights up on the display. The settings you have done are shown on the display in sequence for your confirmation.

Troubleshooting



English

If you are having a problem with your unit, check this list for a possible solution before calling for service. If you cannot solve the problem from the hints given here, or the unit has been physically damaged, call a qualified person, such as your dealer, for service.

Symptom	Cause	Action
No sound is heard.	Connections are incorrect or loose.	Check all connections, and make corrections. (See pages 6 to 8.)
Hard to listen to broadcasts because of noise.	<ul style="list-style-type: none"> Antennas are disconnected. The AM loop antenna is too close to the unit. The FM antenna is not properly extended and positioned. 	<ul style="list-style-type: none"> Reconnect the antennas correctly and securely. Change the position and direction of the AM antenna. Extend the FM antenna at the best position.
The disc sound is discontinuous.	The disc is scratched or dirty.	Clean or replace the disc. (See page 23.)
The disc tray does not open or close.	<ul style="list-style-type: none"> The AC power cord is not plugged in. Trays are locked. 	<ul style="list-style-type: none"> Plug the AC power cord. Unlock the trays. (See page 17.)
The disc does not play.	The disc is placed upside down.	Place the disc with the label side up.
The cassette holders cannot be opened.	Power supply from the AC power cord has been cut off while the tape was running.	Turn on the unit.
Impossible to record.	Small tabs on the back of the cassette are removed.	Cover the holes with adhesive tape.
Operations are disabled.	The built-in microprocessor may malfunction due to external electrical interference.	Unplug the AC power cord and then plug it back in.
Unable to operate the unit from the remote control unit.	<ul style="list-style-type: none"> The path between the remote control unit and the remote sensor on the unit is blocked. The batteries are exhausted. 	<ul style="list-style-type: none"> Remove the obstruction. Replace the batteries.

Specifications

Amplifier

Output Power: 75 watts per channel, min. RMS, both channels driven into 6 ohms at 1 kHz with no more than 0.9% total harmonic distortion.
 Audio input sensitivity/impedance (at 1 kHz):
 AUX: 400 mV/50 kohms

Audio output level:
 AUX: 270 mV

Digital output: CD/OPTICAL DIGITAL OUTPUT

Signal wave length: 660 nm
 Output level: -21 to -15 dBm

Speakers/impedance: 6 - 16 ohms

Tuner

FM tuning range: 87.50 - 108.00 MHz
 AM tuning range: MW: 522 - 1,629 kHz
 LW: 144 - 288 kHz

CD player

CD Capacity: 3 CDs
 Dynamic range: 85 dB
 Signal-to-noise ratio: 90 dB
 Wow and flutter: Immeasurable

Cassette deck

Frequency response: Normal (type I): 50 - 14,000 Hz
 C-CO (type II): 50 - 14,000 Hz
 Metal (type IV): 50 - 14,000 Hz (only for playback)
 Wow and flutter: 0.15% (WRMS)

General

Power requirement: AC 230 V~, 50 Hz.
 Power consumption: 100 watts (at operation)
 14 watts (on standby)
 Dimensions (approx.): 265 x 315 x 341 mm (W/H/D)
 (10 7/8 x 12 7/16 x 13 7/16 in.)
 Mass (approx.): 9.4 kg (20.7 lbs)

Supplied accessories

See page 6.



VICTOR COMPANY OF JAPAN, LIMITED



Design and specifications are subject to change without notice.

CA-MXJ55R/CA-MXJ530R

<<MEMO>>

Description of major ICs

■ BA3835S (IC542):SPI BPF

1. Block Diagrams

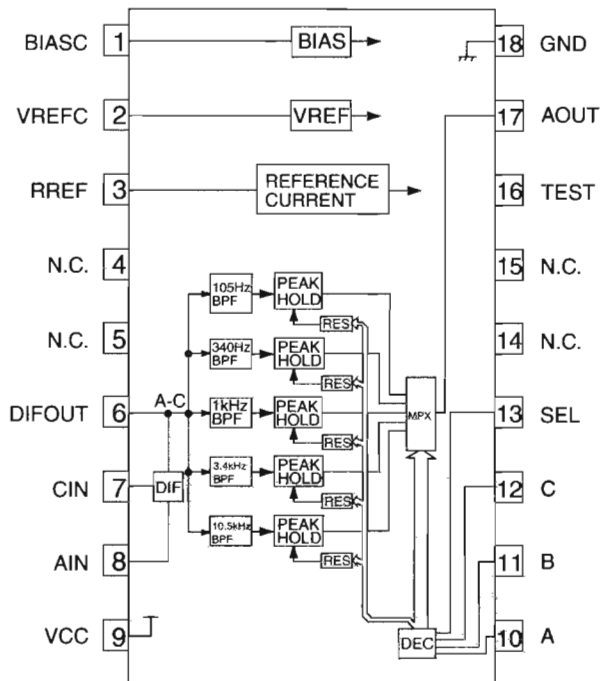

2. Pin Function

No.	Symbol	I/O	Function
1	BIASC	-	Decoupling condenser connection terminal.
2	VREFC	-	Decoupling condenser connection terminal.
3	RREF	-	Reference resistance connection terminal.
4	NC	-	Non connect.
5	NC	-	Connected to GND of audio system through a condenser.
6	DIF OUT	-	Non connect.
7	CIN	-	Connected to GND of audio system through a condenser.
8	AIN	I	Inputs the audio signal through a condenser.
9	VCC	-	Power supply terminal.
10	SPI-A	O	Output selection control terminal.
11	SPI-B	O	Output selection control terminal.
12	SPI-C	O	Output selection control terminal.
13	SPICSB	O	Output selection control terminal.
14	NC	-	Non connect.
15	NC	-	Non connect.
16	TEST	-	Connected to GND upon normal use.
17	AOUT	O	Multi-plexor output terminal.
18	GND	-	Connect to GND.

■ AN8806SB (IC601) : RF&Servo AMP

1. Terminal Layout

PD	1	36	PDAC
LD	2	35	PDBD
LDON	3	34	PDF
LDP	4	33	PDE
VCC	5	32	PDER
RF-	6	31	PDFR
RF OUT	7	30	TBAL
RF IN	8	29	FBAL
C.AGC	9	28	EF-
ARF	10	27	EF OUT
C.ENV	11	26	TE-
C.EA	12	25	TE OUT
CS BDO	13	24	CROSS
BDO	14	23	TE BPF
CS BRT	15	22	VDET
OFTR	16	21	LD OFF
/NRFDET	17	20	VREF
GND	18	19	ENV

2. Block Diagram

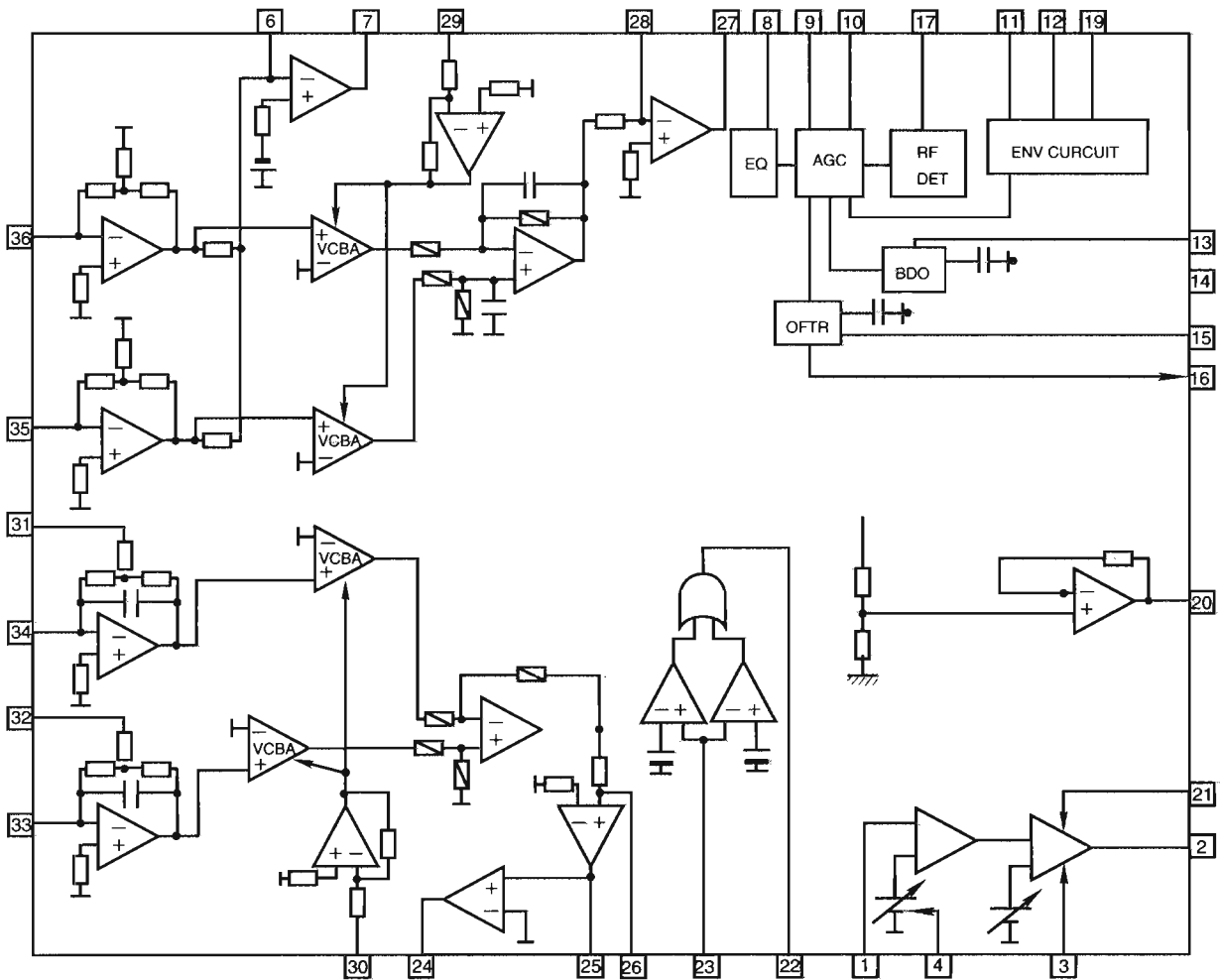

3. Functions

Pin No.	Symbol	I/O	Functions and operations
1	PD	I	APC amp input terminal
2	LD	O	APC amp output terminal
3	LD ON	I	APC ON/OFF control terminal
4	LDP	--	Connect to ground
5	VCC	--	Power supply
6	RF-	I	Inverse input pin for RF amp
7	RF OUT	O	RFamp output
8	RF IN	I	RF input
9	C.AGC	I/O	Connecting pin of AGC loop filter
10	ARF	O	RF output
11	C.ENV	I/O	A capacitor is connected to this terminal to detect the envelope of RF signal
12	C.EA	I/O	A capacitor is connected to this terminal to detect the envelope of RF signal
13	CS BDO	I/O	A capacitor is connected to detect the lower envelope of RF signal
14	BDO	O	BDO output pin
15	CS BRT	I/O	A capacitor is connected to detect the lower envelope of RF signal
16	OFTR	O	Of-track status signal output
17	/NRFDET	O	RF detection signal output
18	GND	--	Ground
19	ENV	O	Envelope output
20	VREF	O	Reference voltage output
21	LD OFF	--	Connect to ground
22	VDET	O	Vibration detection signal output
23	TE BPF	I	Input pin of tracking error through BPF
24	CROSS	O	Tracking error cross output
25	TE OUT	O	Tracking error signal output
26	TE-	I	Inverse input pin for tracking error amp
27	FE OUT	O	Output pin of focus error
28	FE-	I	Inverse input pin for focus error amp
29	FBAL	I	Focus balance control
30	TBAL	I	Tracking balance control
31	PDFR	I/O	F I-V amp gain control
32	PDER	I/O	E I-V amp gain control
33	PDF	I	I-V amp input
34	PDE	I	I-V amp input
35	PD BD	I	I-V amp input
36	PD AC	I	I-V amp input

■ BU4094BCF(IC304,IC303):SERIAL TO PARALLEL PROT EXTENSION

1.Terminal Layout

STORBE	1	16	Vdd
DATA	2	15	OUTPUT ENABLE
CLOCK	3	14	Q5
Q1	4	13	Q6
Q2	5	12	Q7
Q3	6	11	Q8
Q4	7	10	Q's
Vss	8	9	Qs

2.Block Diagram

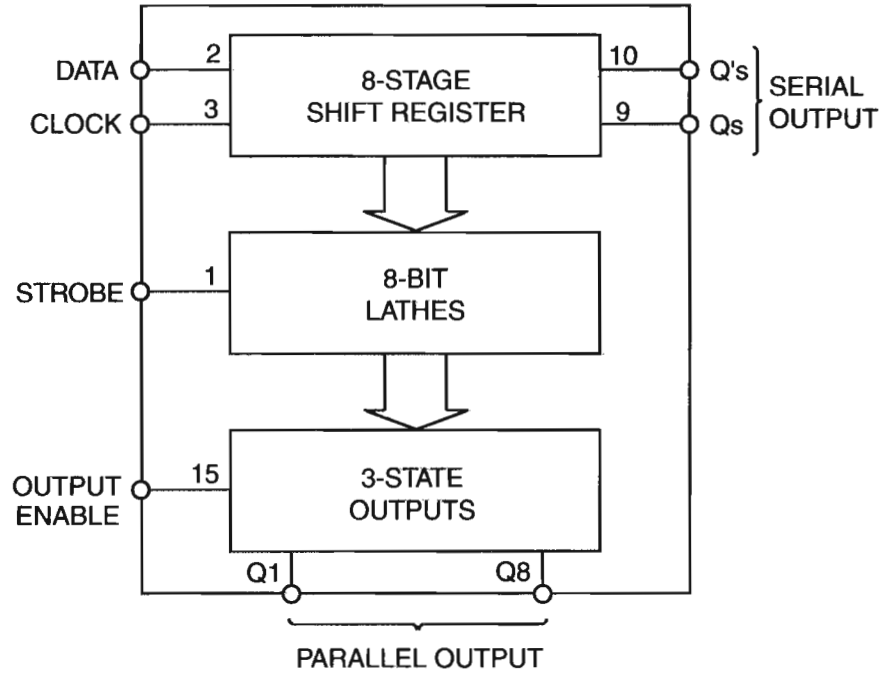

■ BA6897FP(IC801):4channel driver

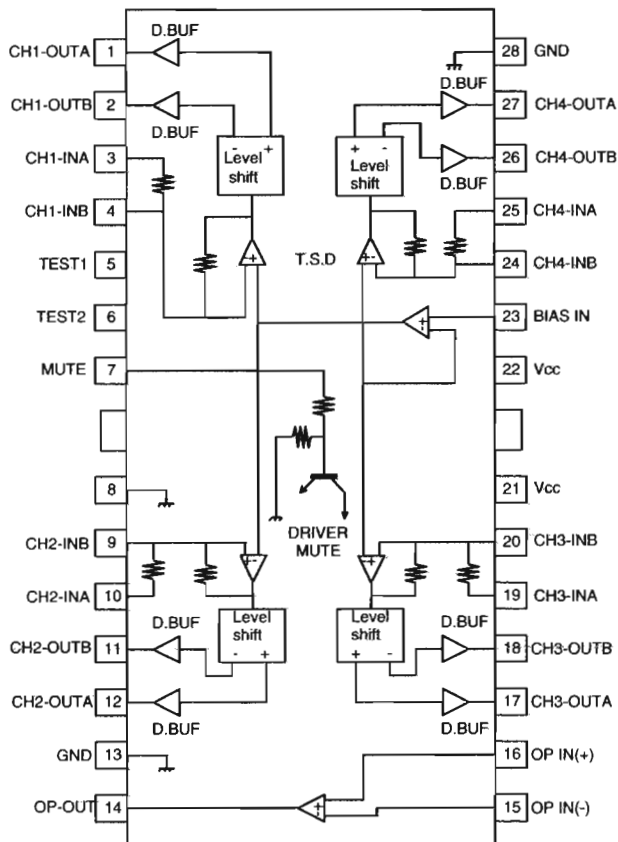

■ LC72136N(IC2):PLL Frequency sinesizer

1. Layout

XT	1	22	XT
FM/AM	2	21	GND
CE	3	20	LPFOUT
DI	4	19	LPFIN
CLOCK	5	18	PD
DO	6	17	VCC
FM/ST/VCO	7	16	FMIN
AM/FM	8	15	AMIN
	9	14	
	10	13	IFCONT
SDIN	11	12	IFIN

2. Block

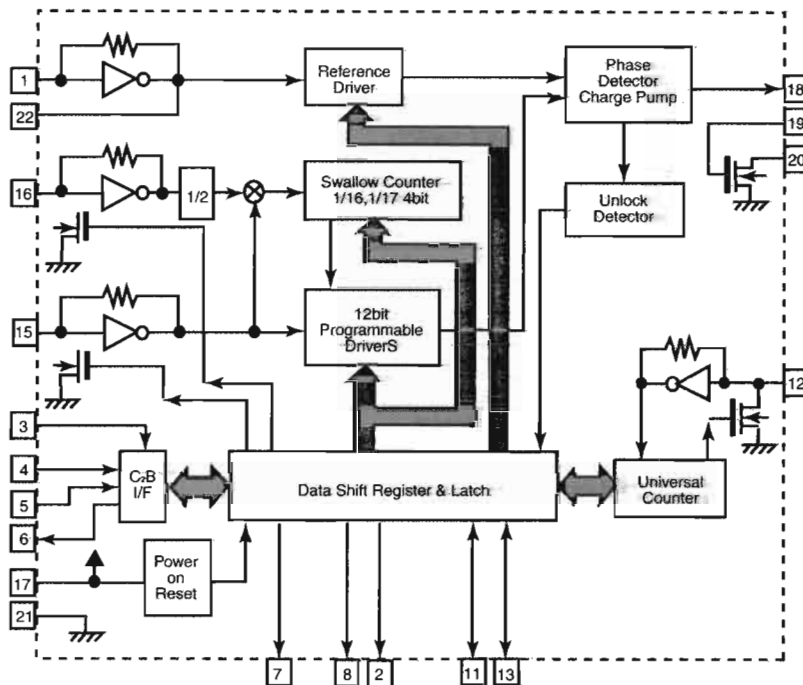

3. Function

Pin No.	Symbol	I/O	Function	Pin No.	Symbol	I/O	Function
1	XT	I	X'tal oscillator connect (75kHz)	12	IFIN	I	IF counter signal input
2	FM/AM	O	LOW:FM mode	13	IFCONT	O	IF signal output
3	CE	I	When data output/input for 4pin(input) and 6pin(output): H	14		-	Not use
4	DI	I	Input for receive the sirisl data from controller	15	AMIN	I	AM Local OSC signal output
5	CLOCK	I	Sync signal input use	16	FMIN	I	FM Local OSC signal input
6	DO	O	Data output for Controller Output port	17	VCC	-	Power suply(VDD=4.5-5.5V) When power ON:Reset circuit move
7	FM/ST/VCO	O	"Low": MW mode	18	PD	O	PLL charge pump output(H: Local OSC frequency Height than Reference frequency. L: Low Agreement: Height impedance)
8	AM/FM	O	Not use	19	LPFIN	I	Input for active lowpassfilter of PLL
9		-	Not use	20	LPFOUT	O	Output for active lowpassfilter of PLL
10		-	Input/output port	21	GND	-	Connected to GND
11	SDIN	I/O	Data input/output	22	XT	I	X'tal oscillator(75KHz)

■ MN101C23DBP3 (IC810) : System controller

Pin No.	Symbol	I/O	Descriptions
1	KCMND	O	VC3 Serial data output
2	MSTAT	I	VC3 Status data input
3	KCLK	I	VC3 Serial clock input
4	DATAOUT	O	SLC/TUNER data output
5	DATAIN	I	SLC/TUNER data input
6	CK	O	SLC/TUNER clock signal output
7	BEAT	O	BEAT Cut signal output of TUNER
8	VDD	-	Power supply +5V
9,10	OSC2,1	I/O	Oscillation terminal (8MHz)
11	VSS	-	Connect to GND
12,13	XI,XO	I/O	Sub clock (32.768kHz)
14	MMOD	-	Connect to GND
15	VREF-	-	Connect to GND
16~19	KEY1~4	I	Key matrix input 1~4
20	SLCKEY1	I	Tape A playback detect switch
21	SLCKEY2	I	Tape B playback detect switch
22	SLCKEY3	I	Tape B playback/recording detect switch
23	SPIDTI	I	SPI data input
24	VREF+	-	Power supply +5V
25	MRDY	I	VC3 ready input
26	RESET	I	Reset signal input
27	PANEL OP	I	Moving panel open detection signal input
28	PANEL CL	I	Moving panel close detection signal input
29	LOAD DET	I	Overload detect signal input
30	MSI	I	MS Detector signal input
31	PROSACK	O	Clock signal output to IC406
32	PROSADA	I	Data input from IC406
33	REMIN	I	Remote control signal input
34	PHOTOA	I	Tape A mechanism running detection signal input
35	PHOTOB	I	Tape B mechanism running detection signal input
36	INH	I	Inhibit signal input
37	RDSCLK	I	Clock signal input from IC4
38	PRT	I	Protector input
39	RDS DATA	I	RDS data input from IC4
40	SPICSB	O	SPI Chip select signal output
41	OSDCLK	-	Not used
42~44	SPIC~A	O	SPI-C~A Data output to IC542
45,46	VOL+/-	I	Volume rotary encoder input (+/-)
47	MPX	I	Stereo detect
48	FVOLDA	O	Front volume data output
49	SLCCE	O	SLC Chip enable signal output to IC303,IC304
50	RVOLDA	O	Rear volume data output
51~59	G9~1	O	FL grid control signal output
60~89	P1~30	O	FL segment control signal output
90	SABCE	O	SA BASS Chip enable signal output
91	PROCE	O	ProLogic Chip enable signal output
92	DSPCE	O	DSP Chip enable signal output
93	EXTCE	O	EXT Chip enable signal output
94	VOLCK	O	Clock signal output to IC401
95	SMUTE	O	System mute control signal output
96	OSDCE	-	Not used
97	POUT	O	Power ON/OFF
98	TUCE	O	TUNER Chip enable signal output
99	VC3RESET	O	VC3 Reset output
100	VPP	-	Power supply

■ TA8409S (IC851.IC852.IC853) : Motor Driver

1. Block Diagram

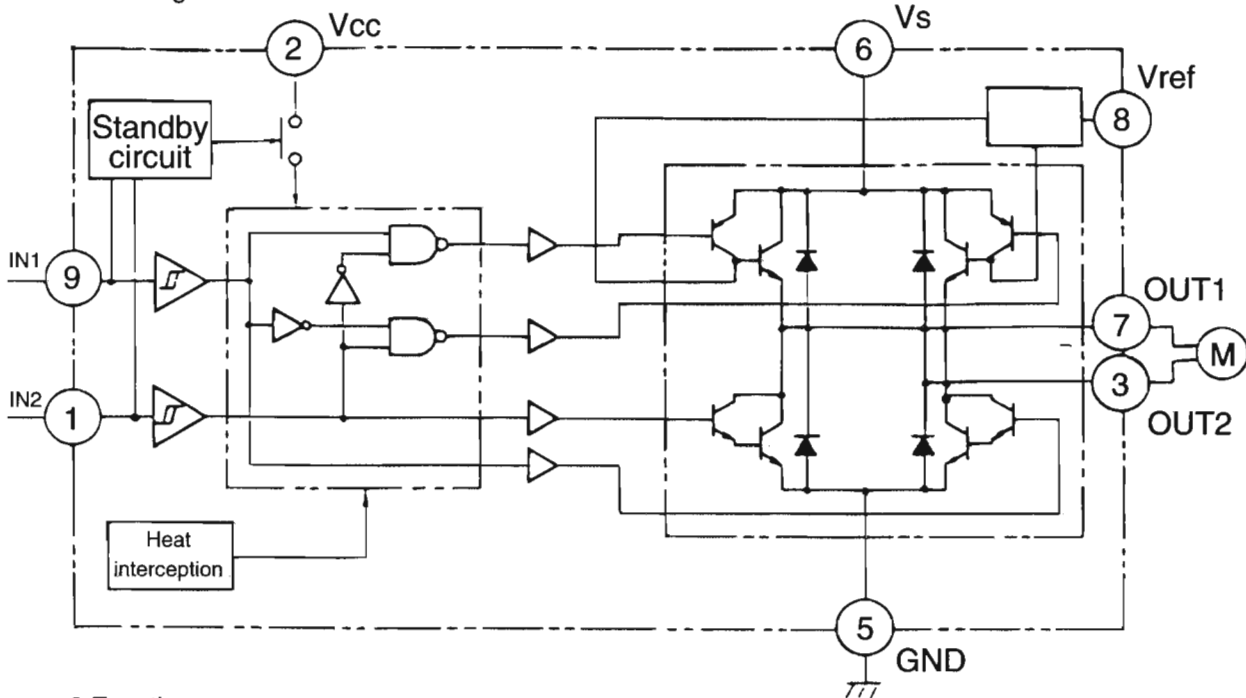

2. Function

INPUT		OUTPUT		MODE
IN1	IN2	OUT1	OUT2	MOTOR
0	0	∞	∞	STOP
1	0	H	L	CW/CCW
0	1	L	H	CCW/CW
1	1	L	L	BRAKE

■ LA2650 (IC406) : SA BASS

1. Terminal Layout/Block diagram

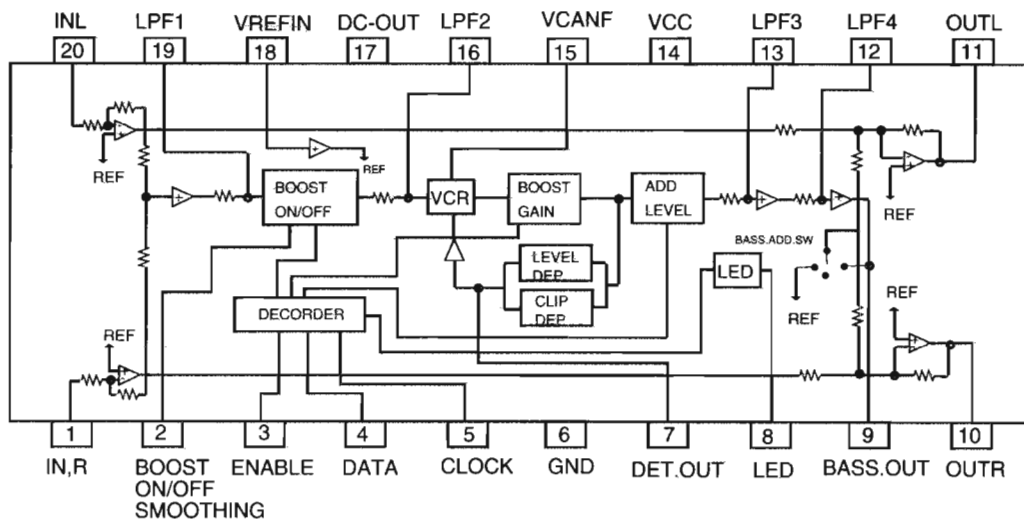

■ MN35510(IC651):DIGITAL SERVO&DIGITAL SIGNAL PROCESSER

1. Terminal Layout

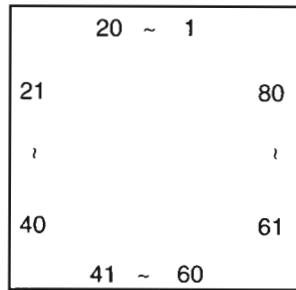

2. Block Diagram

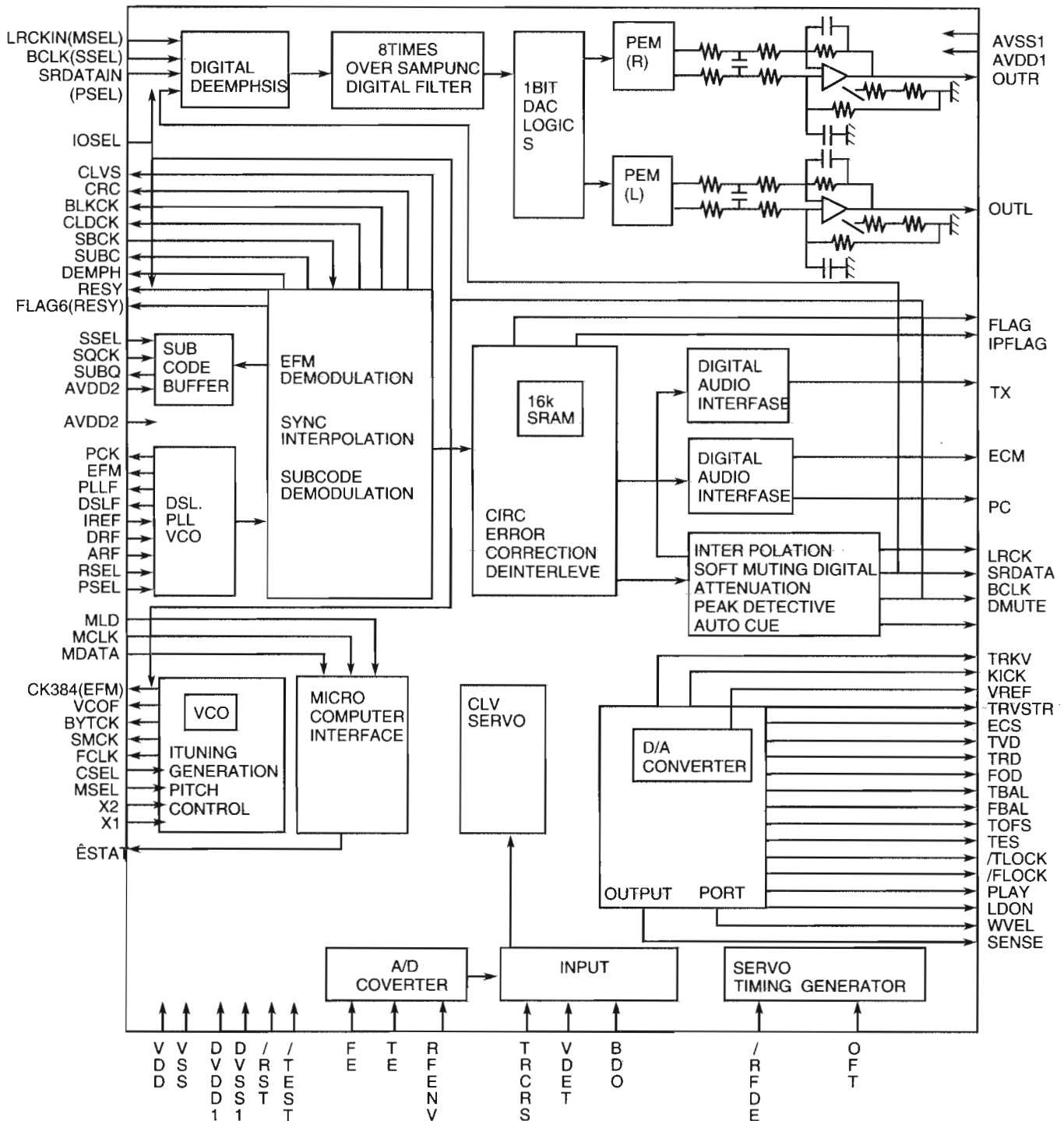

3. Description

Pin No.	symbol	I/O	Description	Pin No.	symbol	I/O	Description
1	BCLK	O	Not used	41	TES	O	Tracking error shunt signal output(H:shunt)
2	LRCK	O	Not used	42	PLAY	-	Not used
3	SRDATA	O	Not used	43	WVEL	-	Not used
4	DVDD1	-	Power supply (Digital)	44	ARF	I	RF signal input
5	DVSS1	-	Connected to GND	45	IREF	I	Reference current input pin
6	TX	O	Digital audio interface output	46	DRF	I	Bias pin for DSL
7	MCLK	I	μ com command clock signal input (Data is latched at signal's rising point)	47	DSLFL	I/O	Loop filter pin for DSL
8	MDATA	I	μ com command data input	48	PLLFL	I/O	Loop filter pin for PLL
9	MLD	I	μ com command load signal input	49	VCOF	-	Not used
10	SENSE	O	Sence signal output	50	AVDD2	-	Power supply(Analog)
11	FLOCK	O	Focus lock signal output Active :Low	51	AVSS2	-	Connected to GND(Analog)
12	TLOCK	O	Tracking lock signal output Active :Low	52	EFM	-	Not used
13	BLKCK	O	sub-code·block·clock signal output	53	PCK	-	Not used
14	SQCK	I	Outside clock for sub-code Q resister input	54	PDO	-	Not used
15	SUBQ	O	Sub-code Q -code output	55	SUBC	-	Not used
16	DMUTE	-	Connected to GND	56	SBCK	-	Not used
17	STATUS	O	Status signal (CRC,CUE,CLVS,TTSTOP,ECLV,SQOK)	57	VSS	-	Connected to GND(for X'tal oscillation circuit)
18	RST	I	Reset signal input (L:Reset)	58	X1	I	Input of 16.9344MHz X'tal oscillation circuit
19	SMCK	-	Not used	59	X2	O	Output of X'tal oscillation circuit
20	PMCK	-	Not used	60	VDD	-	Power supply(for X'tal cscillation circuit)
21	TRV	O	Traverse enforced output	61	BYTCK	-	Not used
22	TVD	O	Traverse drive output	62	CLDCK	-	Not used
23	PC	-	Not used	63	FLAG	-	Not used
24	ECM	O	Spindle motor drive signal (Enforced mode output) 3-State	64	IPPLAG	-	Not used
25	ECS	O	Spindle motor drive signal (Servo error signal output)	65	FLAG	-	Not used
26	KICK	O	Kick pulse output	66	CLVS	-	Not used
27	TRD	O	Tracking drive output	67	CRC	-	Not used
28	FOD	O	Focus drive output	68	DEMPH	-	Not used
29	VREF	I	Reference voltage input pin for D/A output block (TVD,FOD,FBA,TBAL)	69	RESY	-	Not used
30	FBAL	O	Focus Balance adjust signal output	70	IOSEL	-	pull up
31	TBAL	O	Tracking Balance adjust signal output	71	TEST	-	pull up
32	FE	I	Focus error signal input(Analog input)	72	AVDD1	-	Power supply(Digital)
33	TE	I	Tracking error signal input(Analog input)	73	OUT L	O	Lch audio output
34	RF ENV	I	RF envelope signal input(Analog input)	74	AVSS1	-	Connected to GND
35	VDET	I	Vibration detect signal input(H:detect)	75	OUT R	O	Rch audio output
36	OFT	I	Off track signal input(H:off track)	76	RSEL	-	pull up
37	TRCRS	I	Track cross signal input	77	CSEL	-	Connected to GND
38	RFDET	I	RF detect signal input(L:detect)	78	PSEL	-	Connected to GND
39	BDO	I	BDO input pin(L:detect)	79	MSEL	-	Connected to GND
40	LDON	O	Laser ON signal output(H:on)	80	SSEL	-	Pull up

■NJU3711D(IC854) : Mute & Rolling panel motor control

1.Terminal Layout

DOROP	1	14	VDD
DORCL	2	13	CONTB
AUXMUTE	3	12	CONTA
VSS	4	11	CLR
TU+B	5	10	STB
PBMUTE	6	9	CLK
ECHO	7	8	DATA

2.Block Diagram

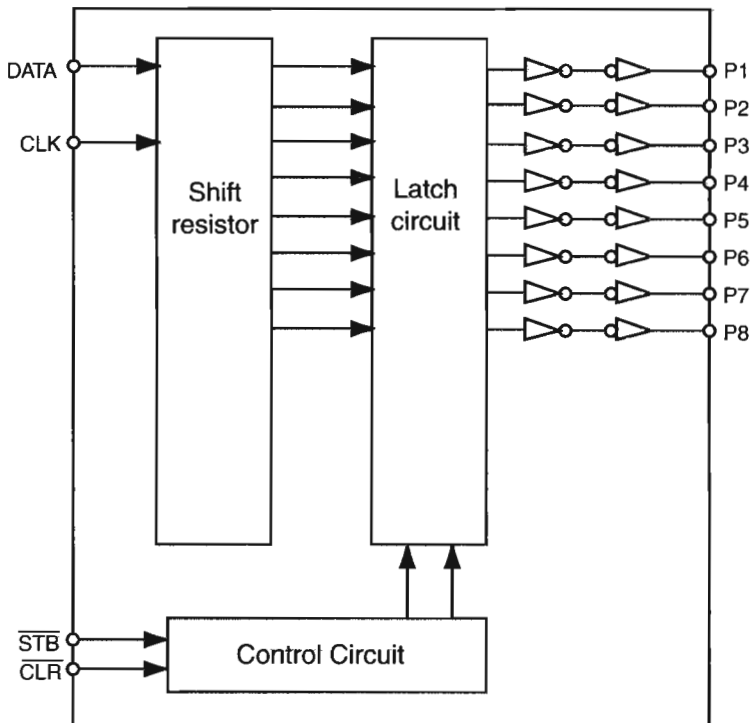

3.Pin Function

PIN No.	I/O	Symbol	Function
1~3	O	DOROP/DORCL/AUXMUTE	Parallel conversion data output terminal.
4	-	VSS	Connect to GND.
5~7	O	TU+B/PBMUTE/ECHO	Parallel conversion data output terminal.
8	I	DATA	Serial data input terminal.
9	I	CLK	Clock signal input terminal.
10	I	STB	Strobe signal input terminal.
11	I	CLR	Clear signal input terminal.
12.13	O	CONTA/CONTB	Parallel conversion data output terminal
14	-	VDD	Power supply.

■ NJU3714D(IC811) : L.E.D.Driver

1. Terminal Layout

RELAY2	1	20	VDD
RELAY1	2	19	CD
DISC1	3	18	TAPE
DISC2	4	17	FM/AM
VSS	5	16	AUX
DISC3	6	15	VSS
SABASS	7	14	CLR
	8	13	STB
DSPRESET	9	12	CLK
SO	10	11	DATA

2. Block Diagram

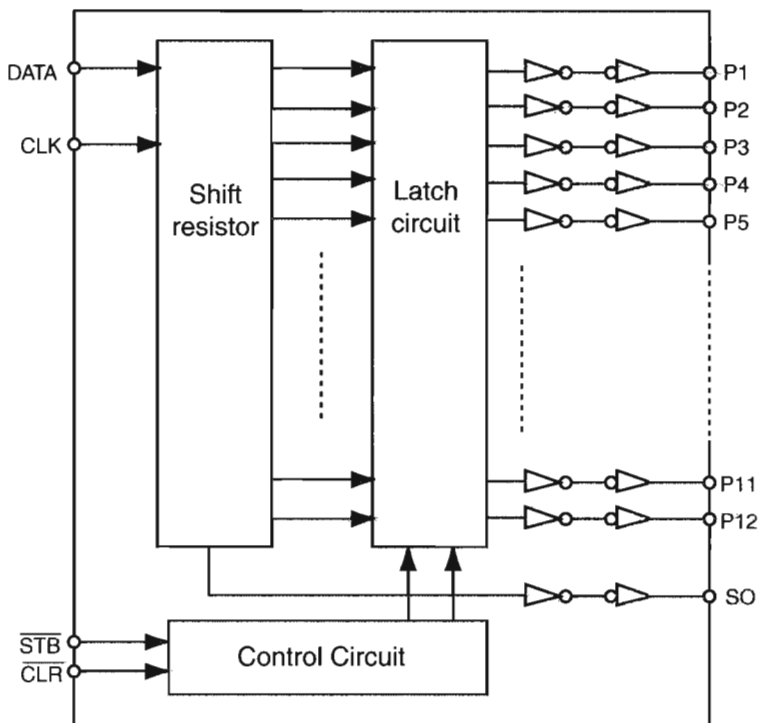

3. Pin Function

PIN No.	I/O	Symbol	Function
1~4	O	RELAY1.2/DISC1.2	Parallel conversion data output terminal.
5	-	VSS	Connect to GND.
6~9	O	DISC3/SABASS/DSPRESET	Parallel conversion data output terminal.
10	O	SO	Serial data output terminal.
11	I	DATA	Serial data input terminal.
12	I	CLK	Clock signal input terminal.
13	I	STB	Strobe signal input terminal.
14	I	CLR	Clear signal input terminal.
15	-	VSS	Connect to GND.
16~19	O	AUX/FM/AM/TAPE/CD	Parallel conversion data output terminal
20	-	VDD	Power supply.

3. Anode connection

	1G	2G, 3G	4G	5G	6G	7G	8G	9G
P1		2a	2a	2a	-		S7	S8
P2	PRO LOGIC	2h	2h	2h	-	SOUND MODE	B1	B1
P3	3 STEREO	2j	2j	2j	REPEAT	1	B2	B2
P4	SLEEP	2k	2k	2k	ALL	S1	B3	B3
P5	DAILY	2b	2b	2b	(ALL) 1	S2	B4	B4
P6	REC	2f	2f	2f	CD	(1)	B5	B5
P7		2m	2m	2m	PROGRAM	(1)	B6	B6
P8		2g	2g	2g	RANDOM	2	B7	B7
P9		2c	2c	2c	1	S3	-	-
P10	STEREO	2e	2e	2e	2	S4	-	-
P11	MONO	2r	2r	2r	3	(2)	-	-
P12	A	2p	2p	2p	4	(2)	-	-
P13	B	2n	2n	2n	5	3	-	-
P14	REC	2d	2d	2d	6	S5	-	-
P15		-	col	kHZ	7	S6	-	-
P16	()	-	Dp	MHZ	8	(3)	-	-
P17		1a	1a	1a	9	(3)	B8	B8
P18		1h	1h	1h	10	-	B9	B9
P19		1j	1j	1j	11	-	B10	B10
P20	R·D·S	1k	1k	1k	12	-	B11	B11
P21	EON	1b	1b	1b	13	-	B12	B12
P22	TA	1f	1f	1f	14	-	B13	B13
P23	NEWS	1m	1m	1m	15	-	B14	B14
P24	INFO	1g	1g	1g	16	-	-	B15
P25	-	1c	1c	1c	-	-	-	B16
P26	-	1e	1e	1e	-	-	-	B17
P27	-	1r	1r	1r	-	-	-	B18
P28	-	1p	1p	1p	-	-	-	B19
P29	-	1n	1n	1n	-	-	-	B20
P30	-	1d	1d	1d	-	-	-	B21

Disassembly method

< Main body >

■ Removing the Metal Cover (See Fig.1 to 3)

1. Remove the six A screws attaching the metal cover on the back of the body.
2. Remove the two B screws attaching the metal cover on both sides of the body.
3. Lift the metal cover on the back of the body and remove it from the body.

CAUTION: DO NOT break the front panel tab fitted to the metal cover.

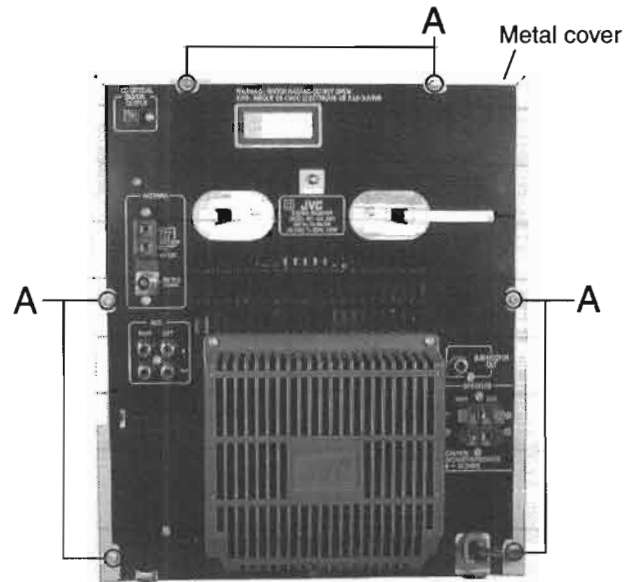

Fig.1

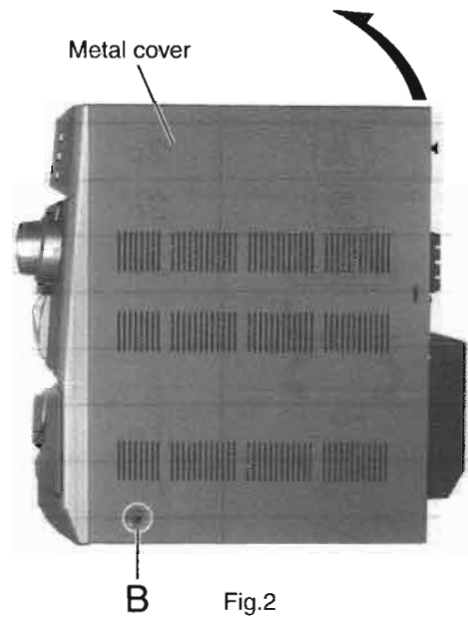

Fig.2



Fig.3

■ Removing the CD Changer Mechanism Assembly (See Fig.4 to 6)

- Prior to performing the following procedure, remove the metal cover.
1. Disconnect the connector CN410 of the card wire connecting the CD changer mechanism board to the main board.
 2. Remove the two C screws on the upper side of the CD changer assembly and the two D screws on the back of the rear panel.
 3. Remove the plastic rivet attaching the main board.
 4. Lift and remove the CD changer mechanism assembly on the back of the body while pulling the rear panel and the front panel assembly.
- * To prevent damage to the CD fitting, be sure to pull the rear panel and the front panel assembly enough to remove the CD changer mechanism.

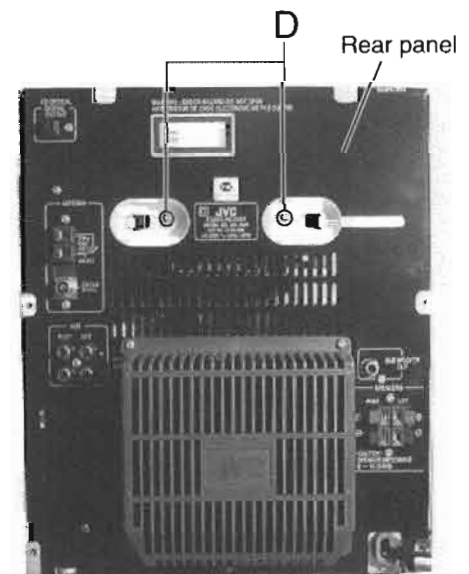
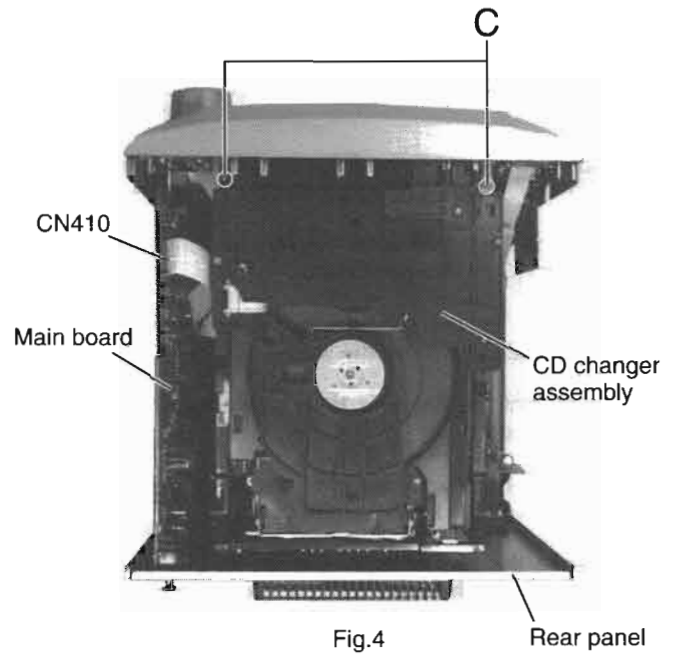

Fig.5

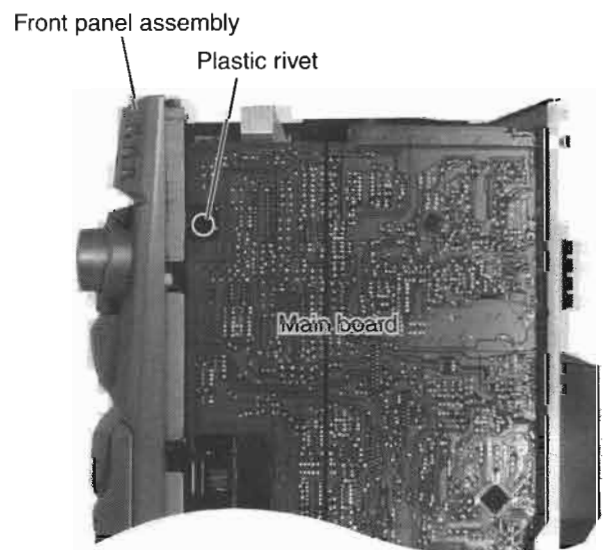

Fig.6

< Front Assembly >

■ Removing the Front Panel Assembly

(See Fig.7 to 9)

- Prior to performing the following procedure, remove the metal cover and CD changer mechanism assembly.
1. Disconnect the card wires from connector CN411, CN412 and CN413 on the main board.
 - It is easy for the previous extraction of POLAR board from CN420 to remove the wire.
 2. Disconnect the flat wire from connector CN703 on the amplifier board.
 3. Remove the four E screws attaching the front panel assembly on the bottom of the body.
 4. Release the two joints(a) and (b) on the lower left and right sides of the body using a screwdriver, and remove the front panel assembly toward the front.

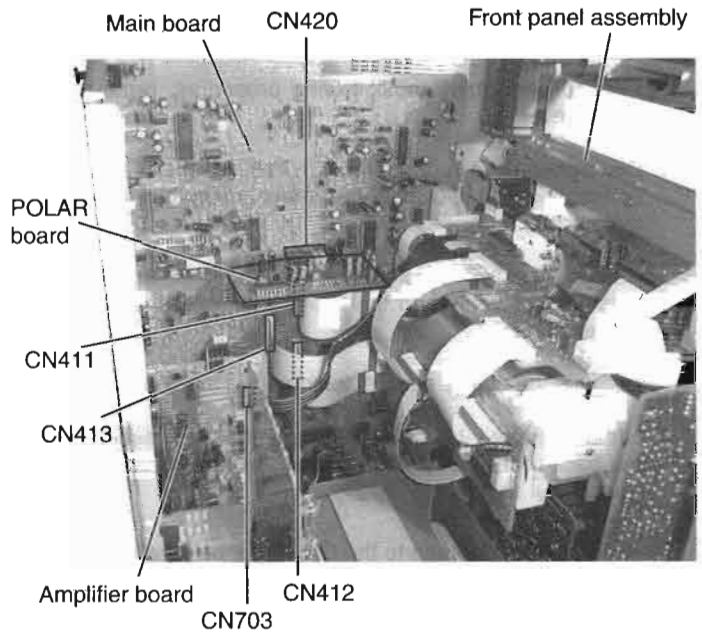

Fig.7

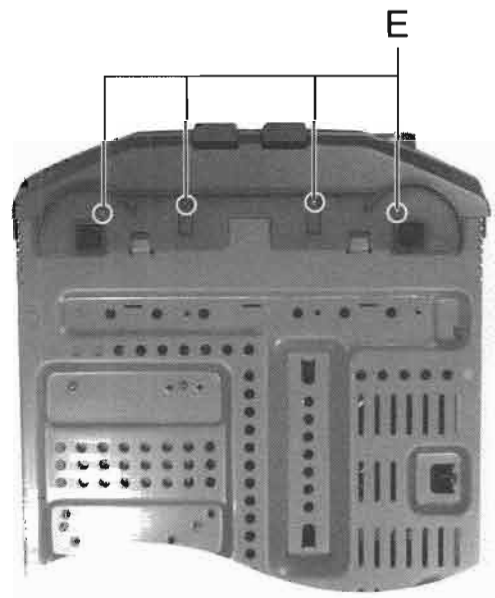
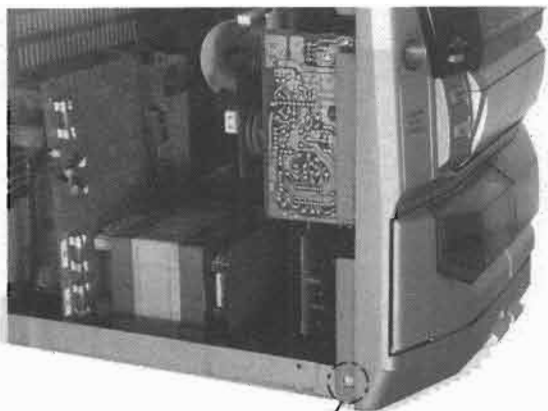
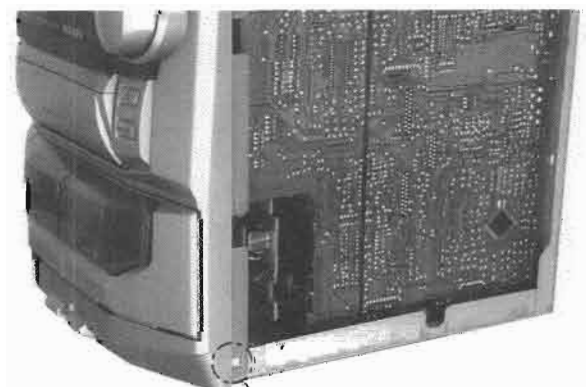

Fig.8



Joint(a)
Fig.9a



Joint(b)
Fig.9b

■ Removing the Rolling panel Panel assembly
(See Fig.10 and 11)

1. Disconnect the card wires from connector CN817, CN812, CN951 and CN816 on the upper system control & FL board and on the rolling panel assembly on the reverse side of the front panel assembly.
 2. Disconnect the card wire from connector CN859 on the relay board on the back of the rolling panel assembly.
 3. Remove the six F screws attaching the stay bracket.
- Remove the four G screws attaching the rolling panel assembly.
4. assembly.

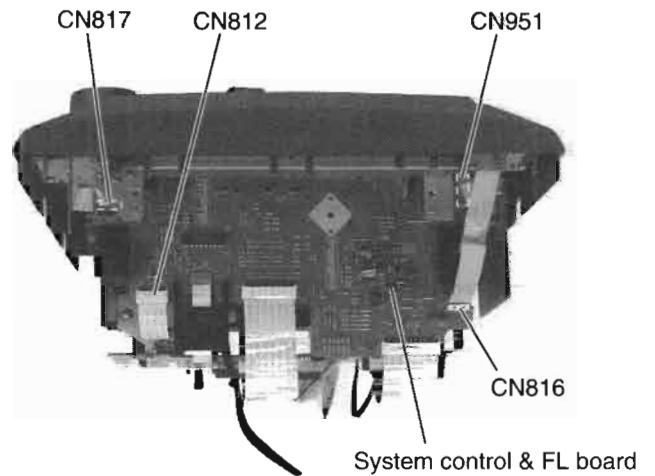

Fig.10

- * Disconnect the flat wire extending from the phones board through the slit of the rolling panel assembly.

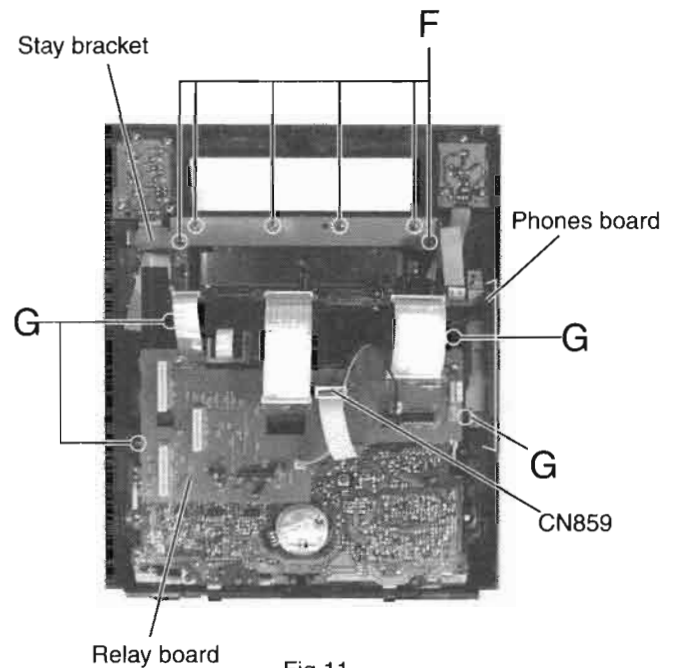

Fig.11

■ Removing the Cassette Mechanism Assembly
(See Fig.12)

- Prior to performing the following procedure, remove the rolling panel assembly.
1. Remove the four H screws and four H1 screws attaching the cassette mechanism assembly.

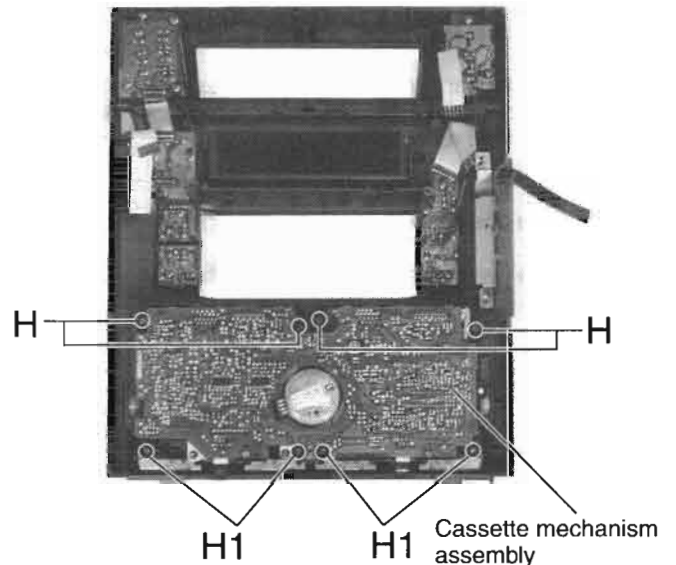

Fig.12

CA-MXJ55R/CA-MXJ530R

■ Removing the System Control & FL Board

(See Fig.13 and 14)

1. Disconnect the card wires and flat wires from connector CN812, CN817, CN816, CN951, CN813, CN810 and CN811 on the system control & FL board respectively.
2. Disconnect the flat wire from connector D851 on the relay board.
3. Remove the six F screws attaching the stay bracket.
4. Remove the two I screws attaching the system control & FL board.

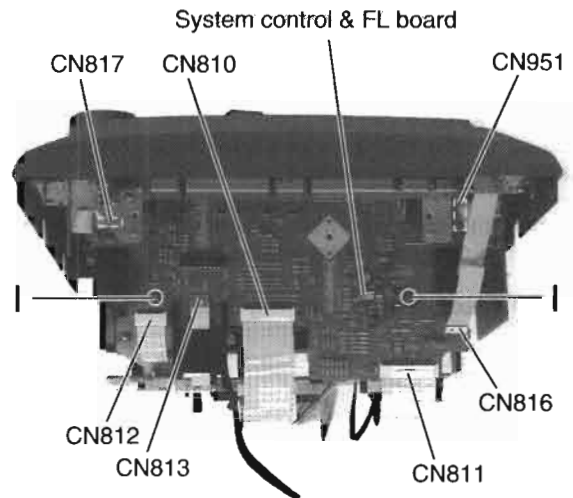

Fig.13

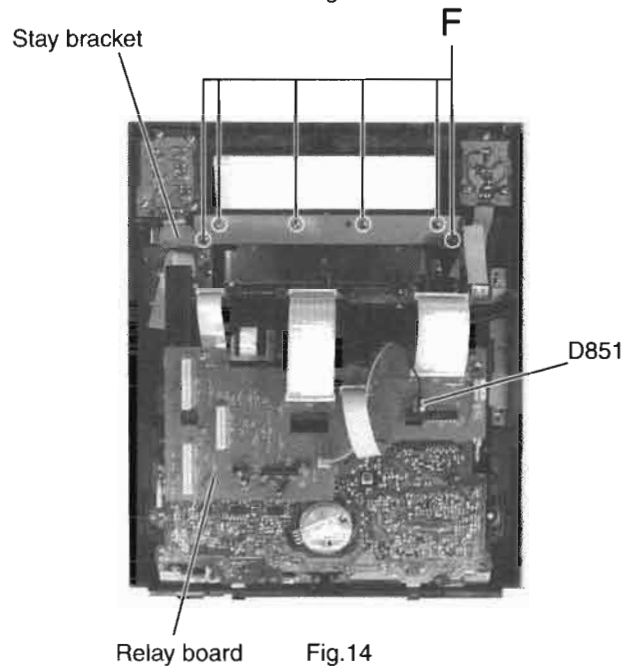

Fig.14

■ Removing the Relay Board (See Fig.15)

1. Disconnect the card wires, the 2P harness and the flat wires from connector CN856, CN857, CN859, CN863, and D851 on the relay board respectively.
2. Remove the one screw J attaching the relay board.
3. Release the five c tabs fitted to the relay board.

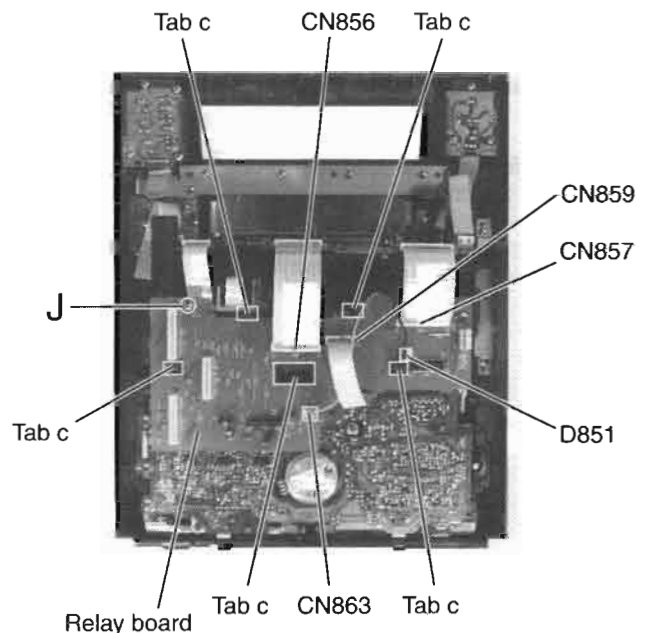

Fig.15

■ Removing Each Board of the Front Panel Assembly (See Fig.16 and 17)

1. Disconnect the flat wire from connector CN816 on the system control & FL board on top of the rolling panel assembly.
2. Remove the three K screws attaching the power switch board.
3. Remove the two L screws attaching the phones board together with bracket.
 - Remove the flat wire extending from the phones board through the slit of the rolling panel assembly.
4. Remove the four M screws attaching the CD eject board and unsolder the flat wire.
 - Remove the rolling panel assembly.
5. Pull out the volume knob and nut toward the front.
6. Remove the two N screws attaching the volume board and unsolder the flat wire.
7. Remove the three O screws attaching the function board 1 and unsolder the flat wire.
8. Remove the four P screws attaching the function board 2.

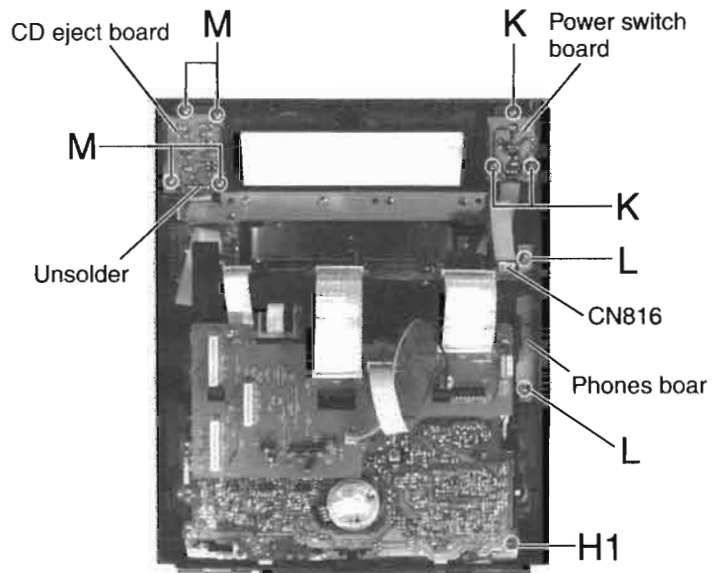

Fig.16

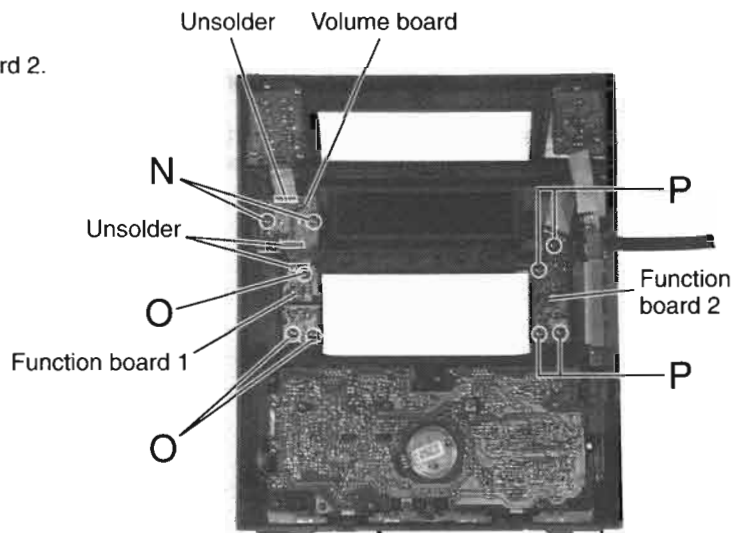

Fig.17

CA-MXJ55R/CA-MXJ530R

< Rear Panel Assembly >

- Prior to performing the following procedure, remove the metal cover and the CD changer mechanism assembly.
- The following procedure can be performed even if the front panel assembly is attached.

■ Removing the Rear Cover (See Fig.18)

1. Remove the two Q screws attaching the rear cover on the back of the body.

■ Removing the Rear Panel (See Fig.18 to 21)

- Prior to performing the following procedure, remove the rear cover.
1. Remove the four R screws attaching the heat sink and the rear panel.
 2. Remove the ten S screws attaching the rear panel.
 3. Release the two joints(d) and (e) on the lower part of the rear panel using a screwdriver, and remove the rear panel toward the rear side.

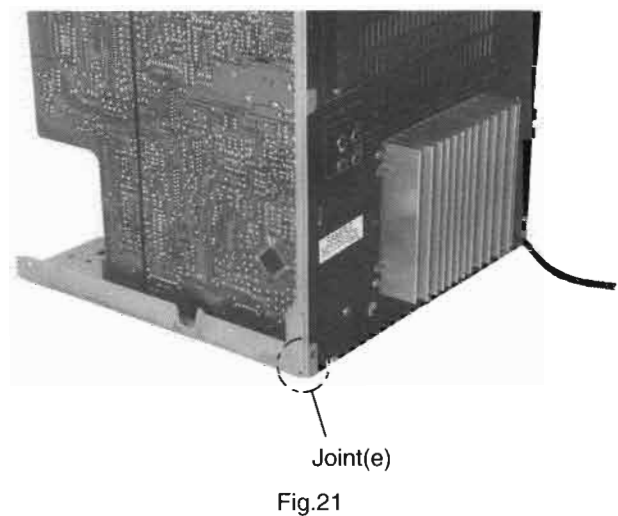
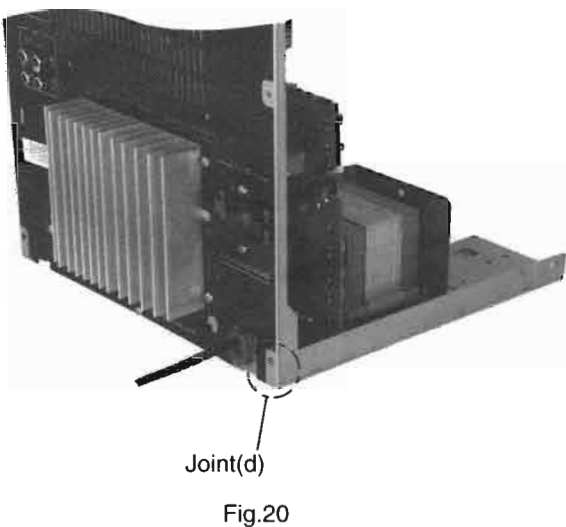
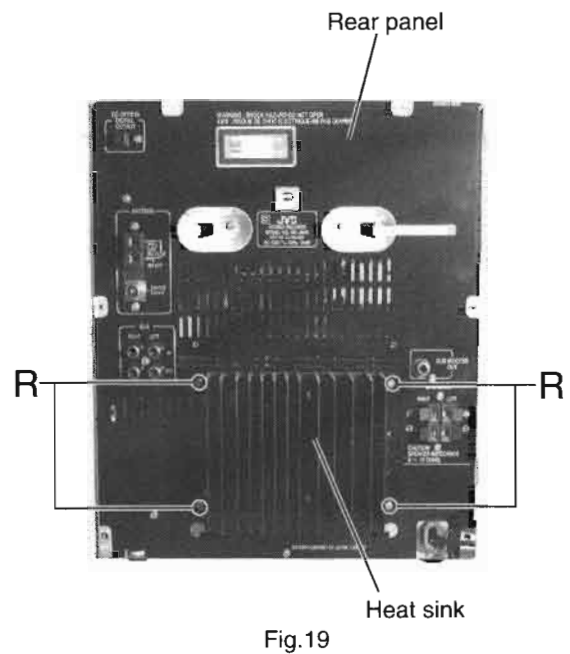
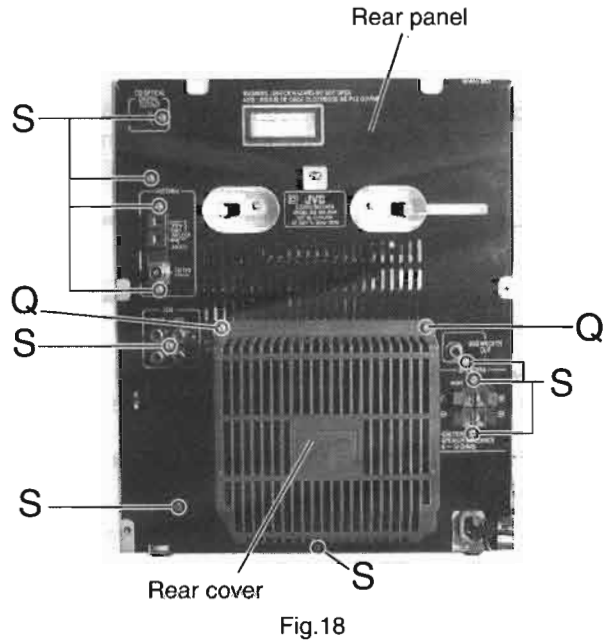

■ **Removing the Main Board** (See Fig.22 and 23)

• Prior to performing the following procedure, remove the metal cover, the CD changer mechanism assembly and the rear panel.

1. Disconnect the card wires from connector CN411, CN412 and CN413 on the main board and the flat wire from connector CN415.

* It is easy for the previous extraction of POLAR board from CN420 to remove the wire.

2. Remove the screw T attaching the main board on the right side of the body.
3. Disconnect connector CN416 and CN417 under the main board, and remove the main board upward.

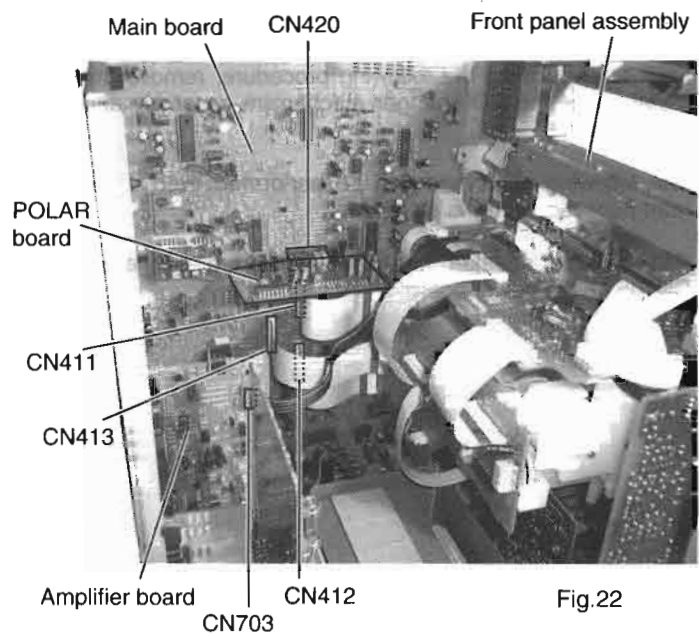

■ **Removing the Rated Voltage Board and Power Amplifier Board** (See Fig.22, 24 and 25)

• Prior to performing the following procedure, remove the metal cover, the CD changer mechanism assembly and the rear panel.

• The following procedure can be performed even if the front panel assembly is attached.

1. Disconnect the flat wire from connector CN703 on the power amplifier board.
2. Disconnect the flat wire from connector CN415 on the main board.
3. Pull out the rated voltage board and the power amplifier board upward from connector CN102 and CN103 on the power board respectively.
4. Remove the two U screws and two V screws attaching the heat sink together with the heat sink bracket.

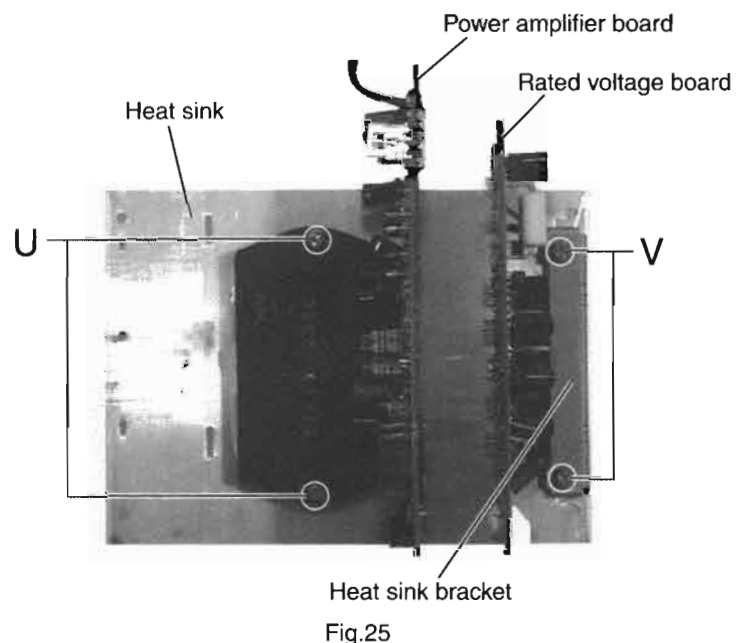
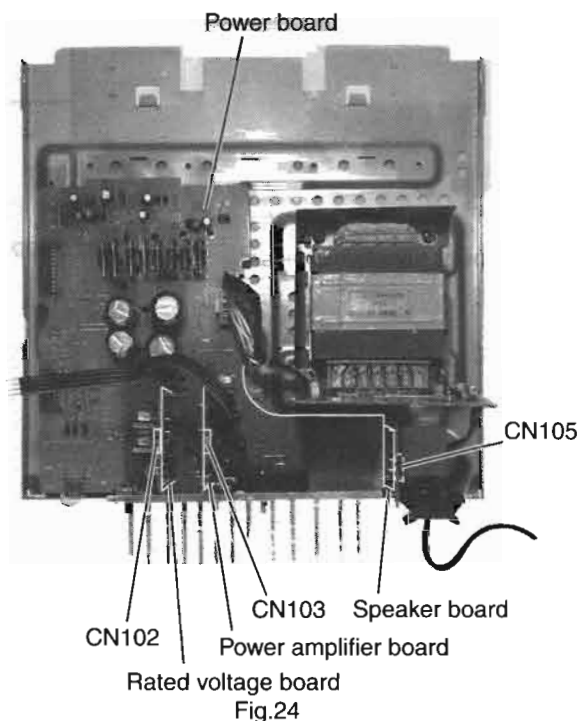
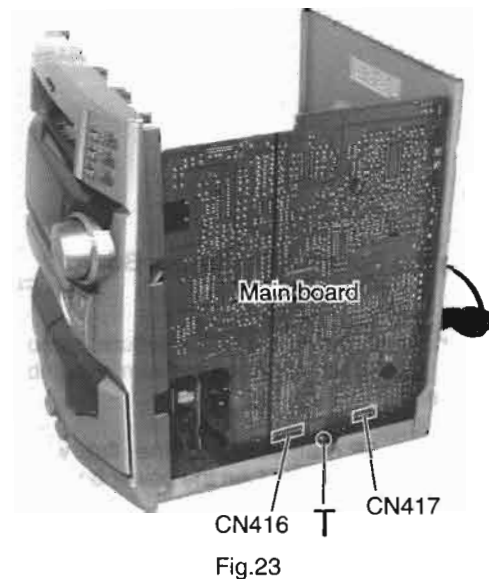

■ **Removing the Speaker Board** (See Fig.24)

- Prior to performing the following procedure, remove the metal cover, the CD changer mechanism assembly and the rear panel.
 - The following procedure can be performed even if the front panel assembly is attached.
1. Pull out the speaker board upward from connector CN105 on the power board.

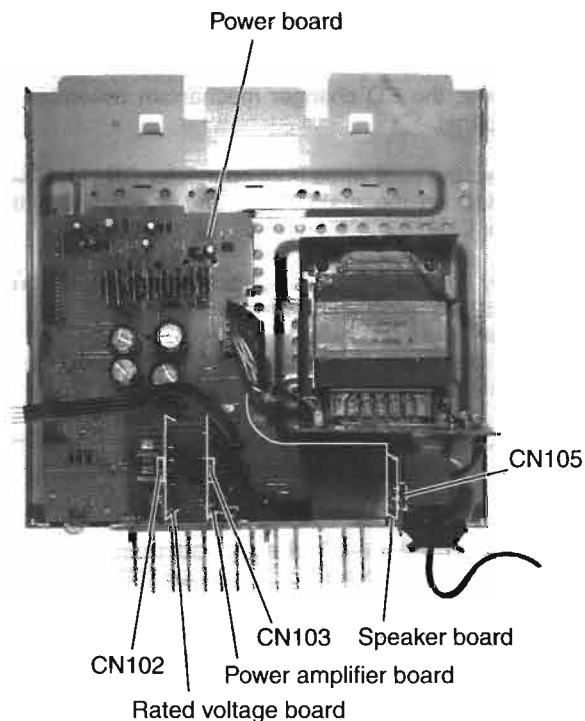

Fig.24

■ **Removing the Power Transformer Board**

(See Fig.26)

- Prior to performing the following procedure, remove the metal cover, the CD changer mechanism assembly and the rear panel.
1. Disconnect the 5P harness and the flat wire from connector CN109 and CN111 on the power board.
 2. Remove the four W screws attaching the power transformer assembly.
 3. Push the cord stopper upward to remove it.

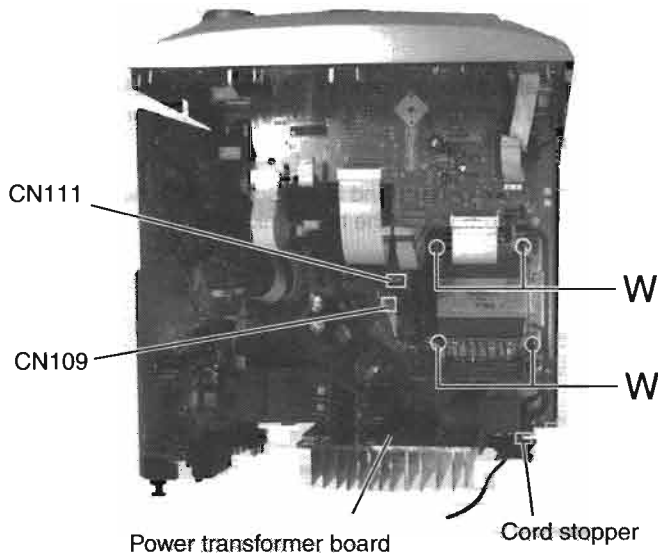

Fig.26

■ Removing the rolling Panel Assembly (See Fig.27)

- 1. Remove the two X screws attaching the rolling panel assembly.
- 2. Remove the rolling panel assembly while pulling outward the left and right hooks attaching the rolling panel assembly.

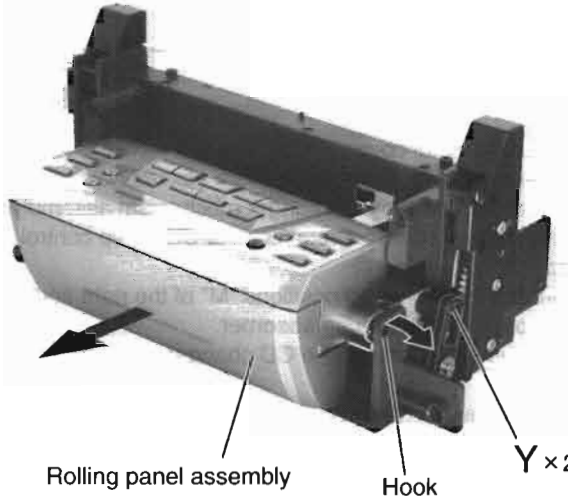

Fig.27

■ Removing the operation switch Board (See Fig.28 and 29)

- 1. Remove the six Y screws attaching the cover and the bracket.
- 2. Release the two f tabs fitted to the bracket, and pull out the left and right panel holders.
- 3. Remove the two Z screws attaching the operation switch board.

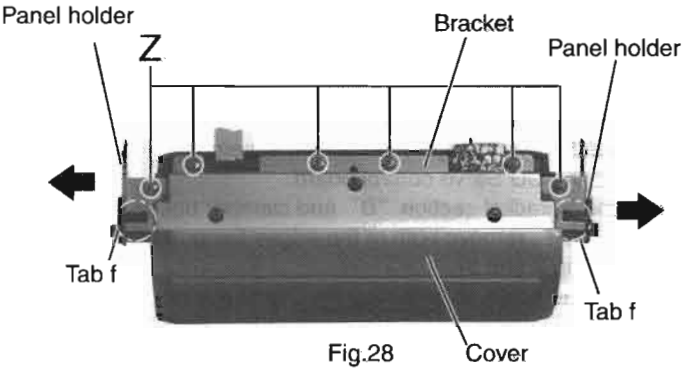

Fig.28

■ Removing the Drive Motor (See Fig.30 and 31)

- 1. Remove the two A screws and the two B screw attaching
- 2. Pull out the gear shaft "a" upward.
- 3. Remove the motor belt.

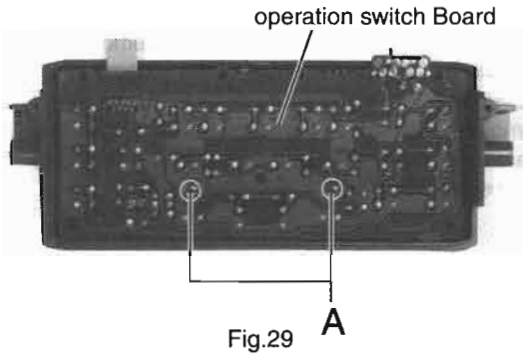

Fig.29

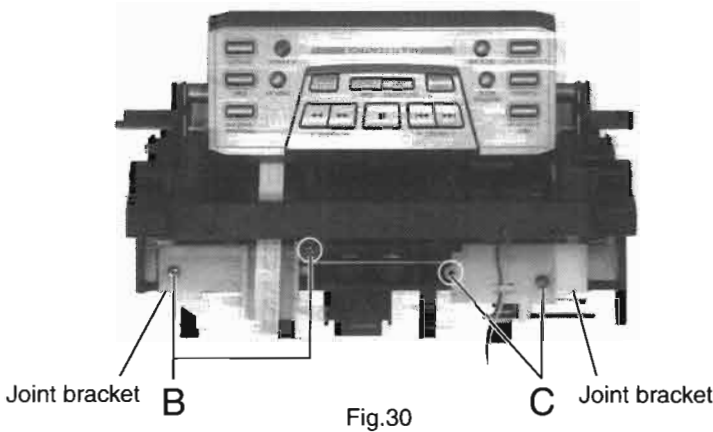

Fig.30

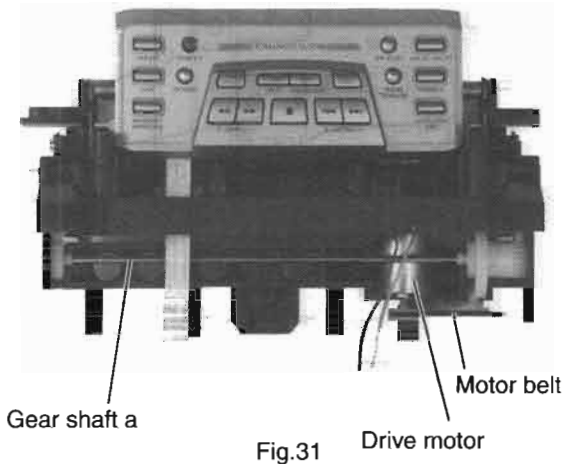

Fig.31

CA-MXJ55R/CA-MXJ530R

«CD Changer Mechanism Type:VC3 Section»

■ Removing the CD Servo control board (See Fig.1)

- 1.Remove the metal cover.
- 2.Remove the CD changer mechanism assembly.
- 3.From bottom side the CD changer mechanism assembly, remove the two screws 1 retaining the CD servo control board.
- 4.Absorb the four soldered positions "M" of the right and left motors with a soldering absorber.
- 5.Pull out the earth wire on the CD changer mechanism assembly.
- 6.The two screws A is removed and C.B.holder is detached.
- 7.Disconnect the connector CN854 on the CD servo control board.
- 8.Disconnect the card wire CN601 and the connector CN801 on the CD servo control board.

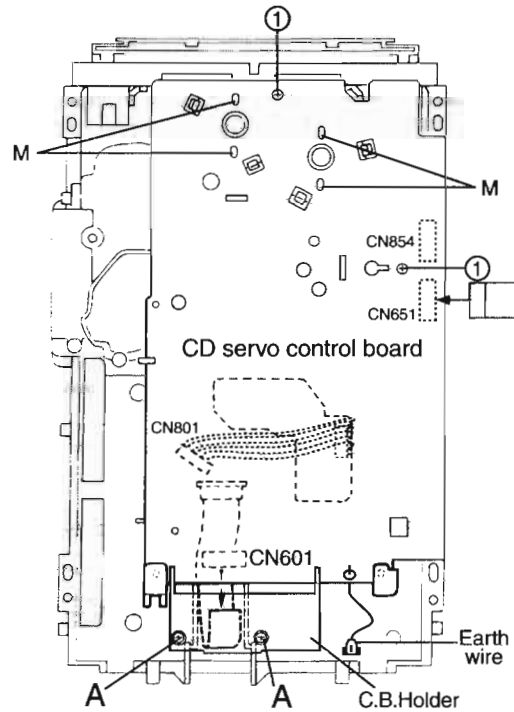

Fig.1

■ Removing the CD tray assembly (See Fig.2~4)

1. Remove the front panel assembly.
2. Remove the CD changer mechanism assembly.
3. Remove the CD Servo control board.
4. From the T.bracket section "B" and clamber base section "C", remove both of the edges fixing the rod(See Fig.2 and 3).
5. Remove the screw 2 retaining the Disc stopper (See Fig.3).
6. Remove the three screws 3 retaining the T.bracket (See Fig.3).
7. Remove the screws 4 retaining the clamber assembly (See Fig.3).
8. From the left side face of the chassis assembly, remove the one screw 5 retaining both of the return spring and lock lever(See Fig. 4).
9. By removing the pawl at the section "D" fixing the return spring, dismantle the return spring(See Fig.4).
10. Remove the three lock levers(See Fig.4).

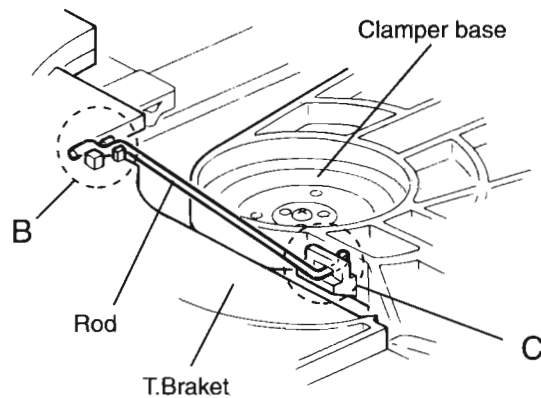

Fig.2

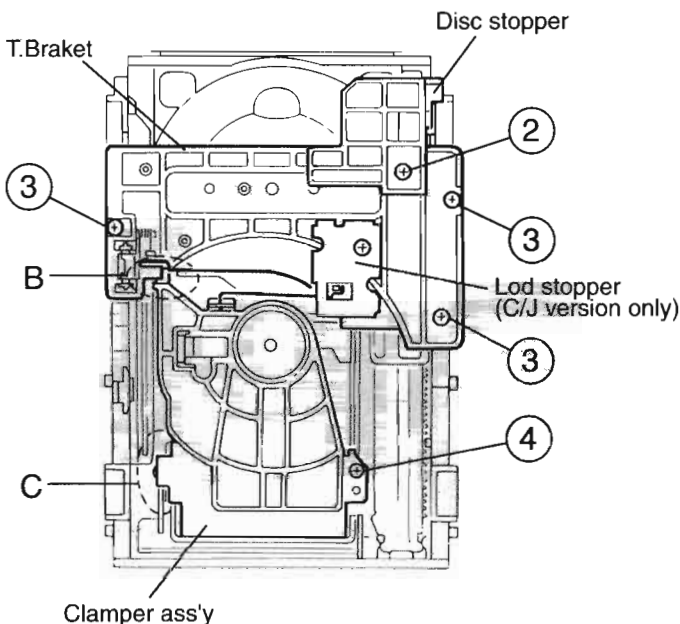

Fig.3

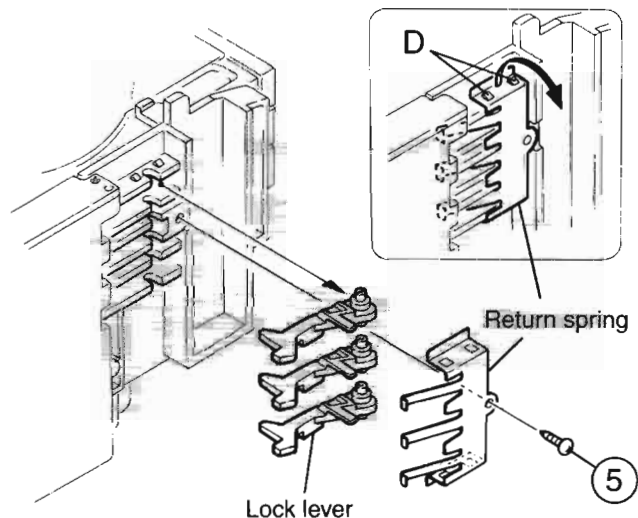

Fig.4

11. Check whether the lifter unit stopper has been caught into the hole at the section "E" of CD tray assembly as shown in Fig.5.

12. Make sure that the driver unit elevator is positioned as shown in Fig.6 from to the second or fifth hole on the left side face of the CD changer mechanism assembly.

[Caution] In case the driver unit elevator is not at above position, set the elevator to the position as shown in Fig.7 by manually turning the pulley gear as shown in Fig.8.

13. Manually turn the motor pulley in the clockwise direction until the lifter unit stopper is lowered from the section "E" of CD tray assembly(See Fig.8).

14. Pull out all of the three stages of CD tray assembly in the arrow direction "F" until these stages stop (See Fig.6).

15. At the position where the CD tray assembly has stopped, pull out the CD tray assembly while pressing the two pawls "G and G'" on the back side of CD tray assembly(See Fig.9). In this case, it is easy to pull out the assembly when it is pulled out first from the stage CD tray assembly.

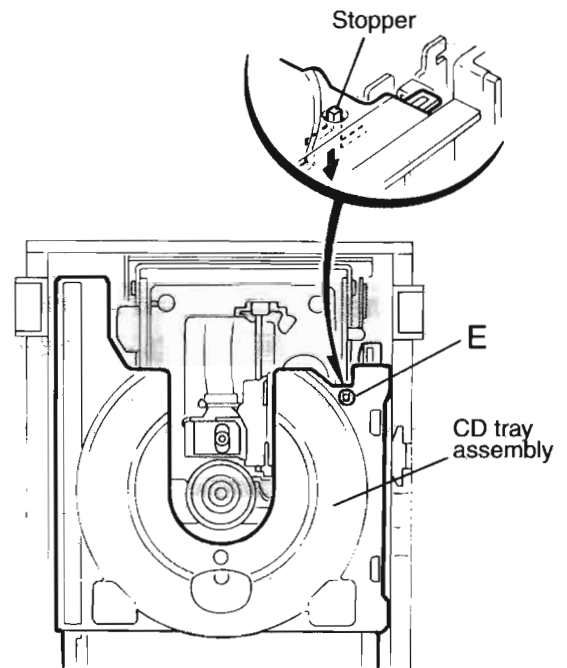

Fig.5

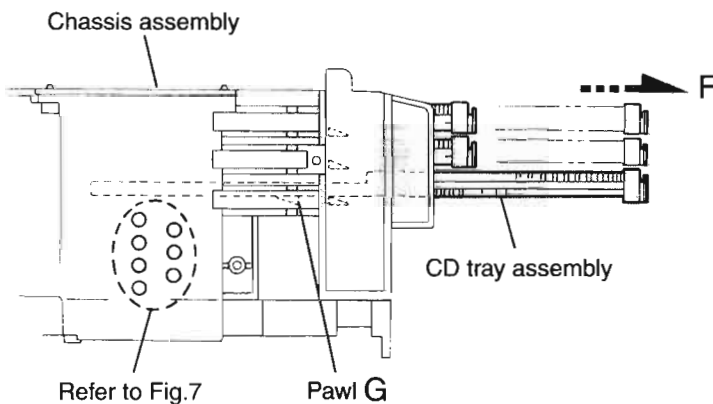

Fig.6

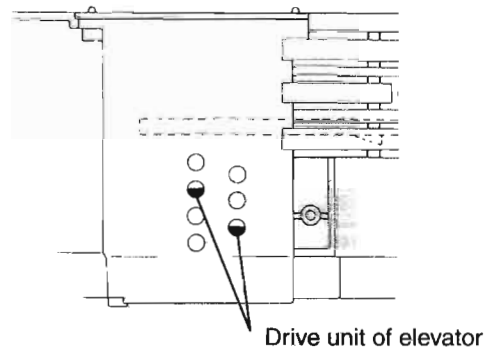

Fig.7

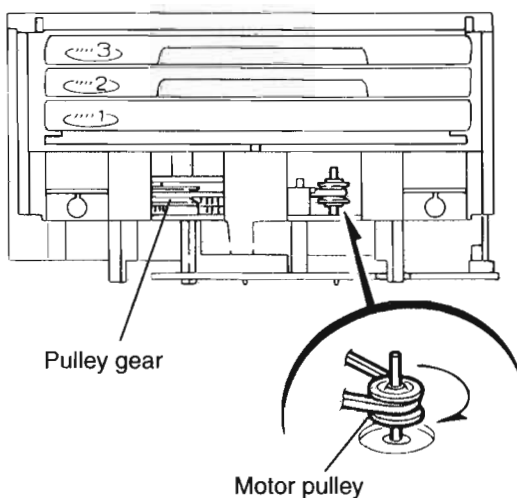

Fig.8

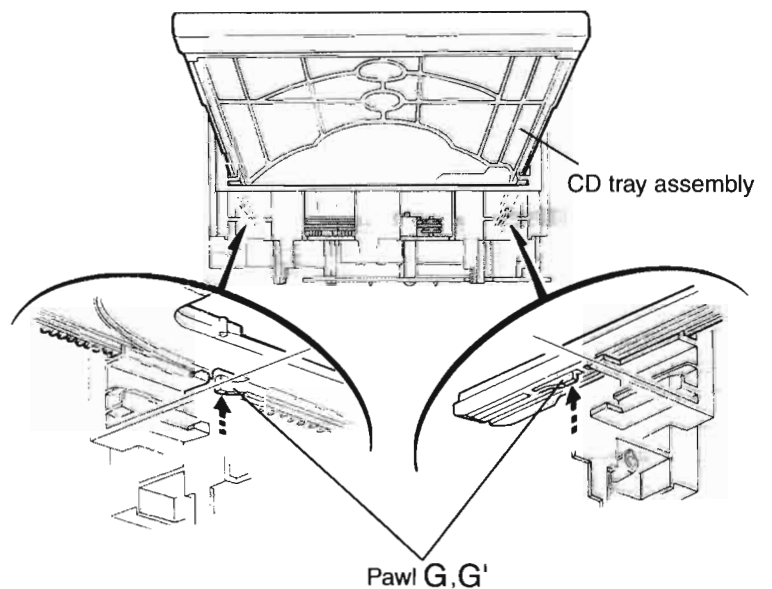

Fig.9

Removing the CD loading mechanism assembly(See Fig.10)

1. While turning the cams R1 and R2 assembly in the arrow direction "H" , align the shaft "I" of the CD loading mechanism assembly to the position shown in Fig.10.
2. Fig.10.
Remove the four screws 6 retaining the CD loading mechanism assembly.

Removing the CD traverse mechanism (See Fig.11 and 12)

1. For dismantling only the CD traverse mechanism without removing the CD loading mechanism assembly, align the shaft "J" of the CD loading mechanism assembly to the position shown Fig.11 while turning the cam R1 and R2 assembly in the arrow direction "K" .
2. By raising the CD loading mechanism assembly in the arrow direction "L" , remove the assembly from the lifter unit

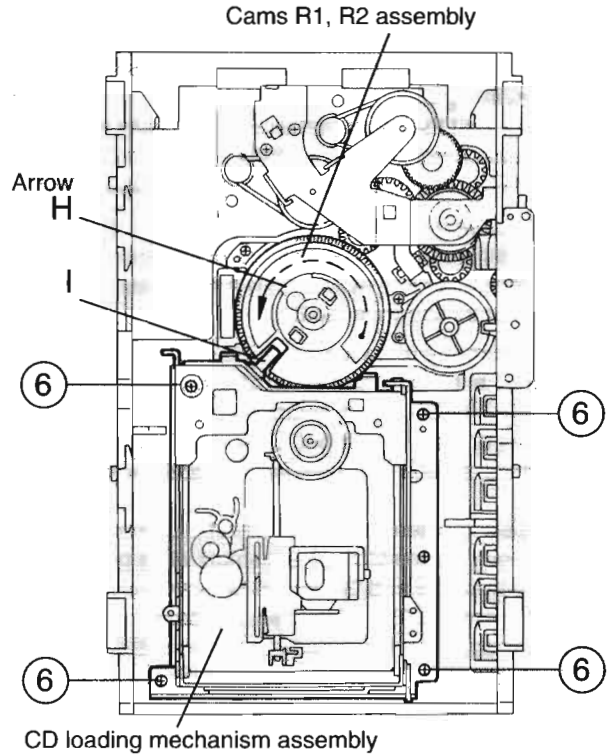

Fig.10

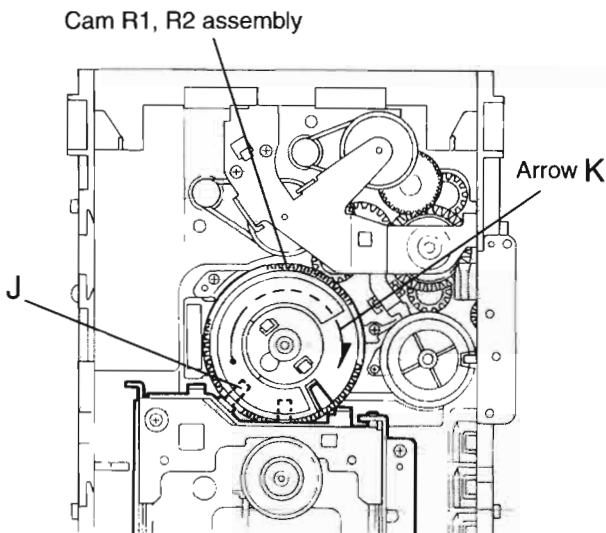

Fig.11

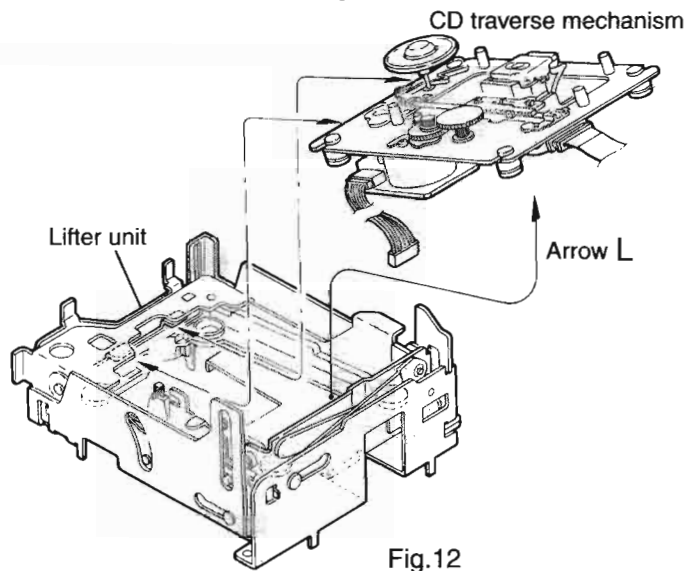

Fig.12

Removing the CD pick unit (See Fig.13)

1. Move the cam gear in the arrow direction a . Then, the CD pickup unit will be moved in the arrow direction b .
2. According to the above step, shift the CD pickup unit to the center position.
3. While pressing the stopper retaining the shaft in the arrow direction c , pull out the shaft in the arrow direction d .
4. After dismantling the shaft from the CD pickup unit, remove the CD pickup unit

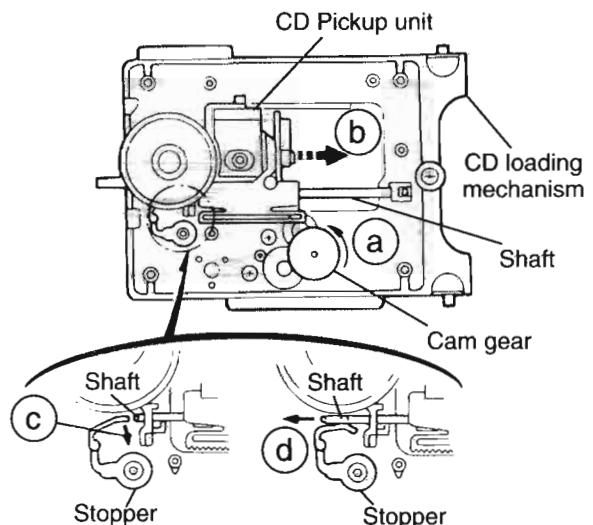

Fig.13

■ Removing the cam unit

(See Fig.14 ~17)

1. Remove the CD loading mechanism assembly.
2. While turning the cam gear L, align the pawl "N" position of the drive unit to the notch position(Fig.16) on the cam gear L.
3. Pull out the drive unit and cylinder gear(See Fig.17).
4. While turning the cam gear L, align the pawl "O" position of the select lever to the notch position(Fig.18) on the cam gear L.
5. Remove the four screws 9 retaining the cam unit(cam gear L and cams R1/R2 assembly)(See Fig.18).

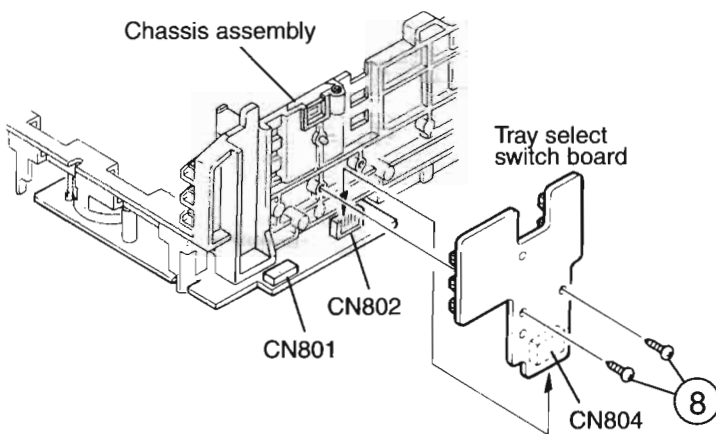

Fig.14

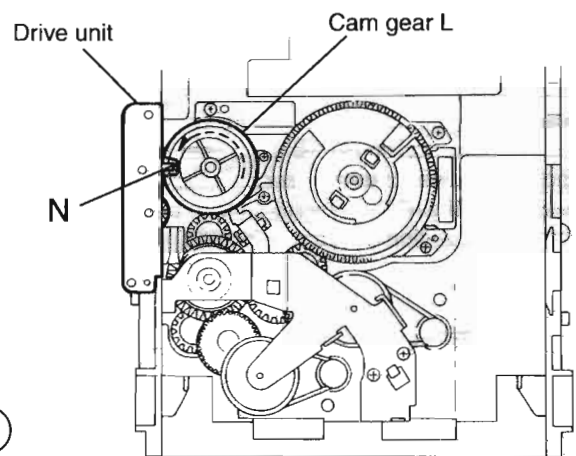

Fig.15

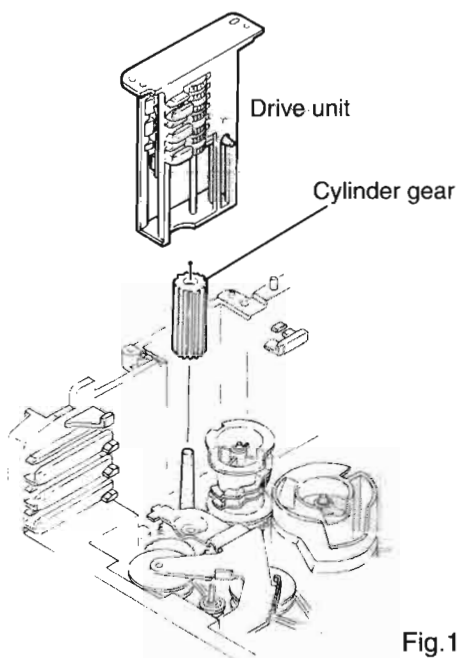

Fig.16

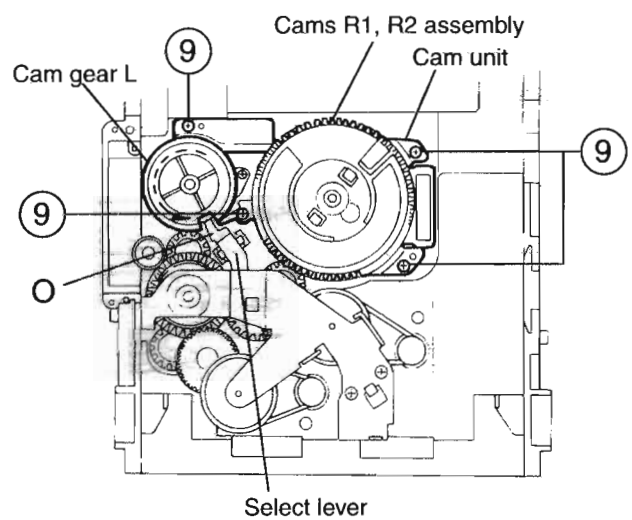

Fig.17

**■Removing the actuator motor and belt
(See Fig.18~21)**

1. Remove the two screws 10 retaining the gear bracket (See Fig. 19).
2. While pressing the pawl "P" fixing the gear bracket in the arrow direction, remove the gear bracket (See Fig. 19).
3. From the notch "Q section" on the chassis assembly fixing the edge of gear bracket, remove and take out the gear bracket(See Fig. 20).
4. Remove the belts respectively from the right and left actuator motor pulleys and pulley gears(See Fig. 19).
5. After turning over the chassis assembly, remove the actuator motor while spreading the four pawls "R" fixing the right and left actuator motors in the arrow direction(See Fig. 21).

[Note] When the chassis assembly is turned over under the conditions wherein the gear bracket and belt have been removed, then the pulley gear as well as the gear, etc. constituting the gear unit can possibly be separated to pieces. In such a case, assemble these parts by referring to the assembly and configuration diagram in Fig. 22.

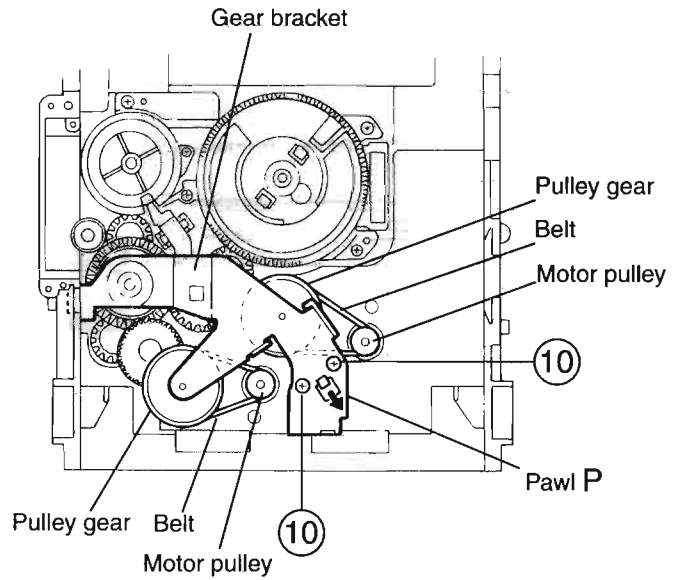

Fig.18

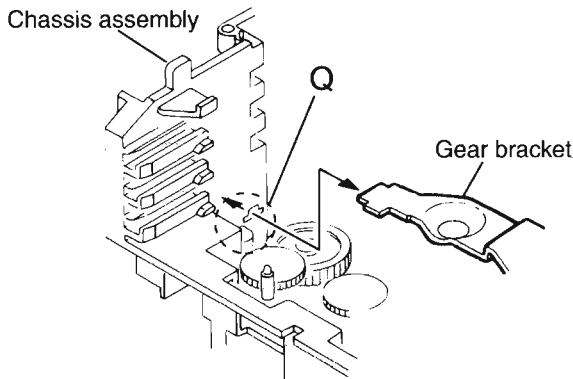

Fig.19

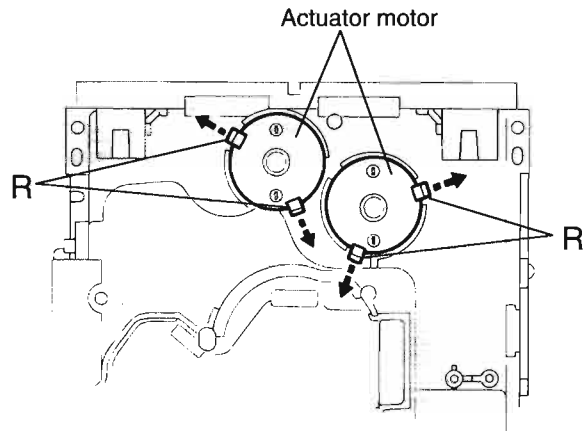

Fig.20

Assembly and Configuration Diagram

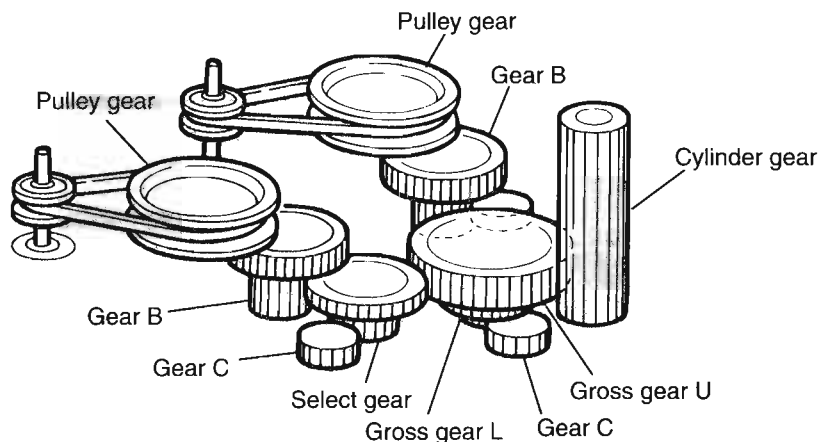

Fig.21

■ Removing the cams R1/R2 assembly and cam gear L (See Fig.22)

1. Remove the slit washer fixing the cams R1 and R2 assembly.
2. By removing the two pawls "S" fixing the cam R1, separate R2 from R1.
3. Remove the slit washer fixing the cam gear L.
4. Pull out the cam gear L from the C.G. base assembly.

■ Removing the C.G. base assembly (See Fig.22 and 23)

Remove the three screws 11 retaining the C.G. base assembly.

[Caution] To reassemble the cylinder gear, etc. with the cam unit (cam gear and cans R1/R2 assembly), gear unit and drive unit, align the position of the pawl "N" on the drive unit to that of the notch on the cam gear L. Then, make sure that the gear unit is engaged by turning the cam gear L. (See Fig. 24).

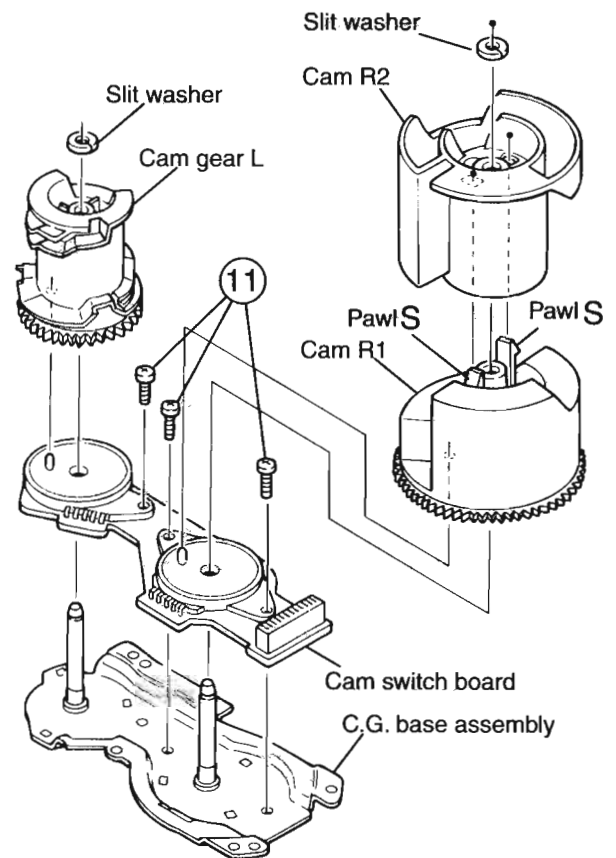

Fig.22

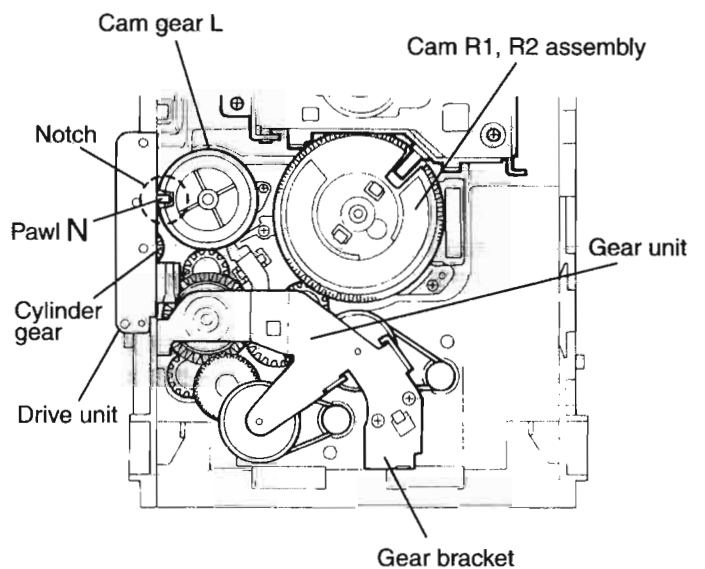

Fig.23

< Cassette Mechanism Section >

■ Removing the Playback, Recording and Eraser Heads

1. While shifting the trigger arms seen on the right side of the head mount in the arrow direction, turn the flywheel R in counterclockwise direction until the head mount has gone out with a click (See Fig 1).
2. When the flywheel R is rotated in counterclockwise direction, the playback head will be turned in counterclockwise direction from the position in Fig 2 to that in Fig 3.
3. At this position, disconnect the flexible P.C. board (outgoing from the playback head) from the connector CN301 on the head amp. and mechanism control P.C. board.
4. After dismantling the FPC holder, remove the flexible P.C. board.
5. Remove the flexible P.C. board from the chassis base.
6. Remove the spring "a" from behind the playback head.
7. Loosen the reversing azimuth screw retaining the playback head.
8. Take out the playback head from the front of the head mount.
9. The recording and eraser heads should also be removed similarly according to Steps 1~8 above.

● Reassembling the Playback, Recording and Eraser Heads

1. Reassemble the playback head from the front of the head mount to the position as shown in Fig 3.
2. Fix the reversing azimuth screw.
3. Set the spring a from behind the playback head.
4. Attach the flexible P.C. board to the chassis base, and fix it with the FPC holder as shown in Fig 3.
5. The recording and eraser heads should also be reassembled similarly according to Steps 1~4 above.

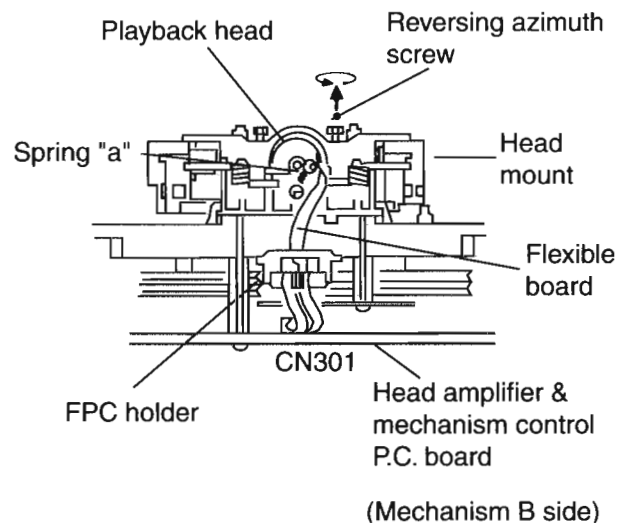
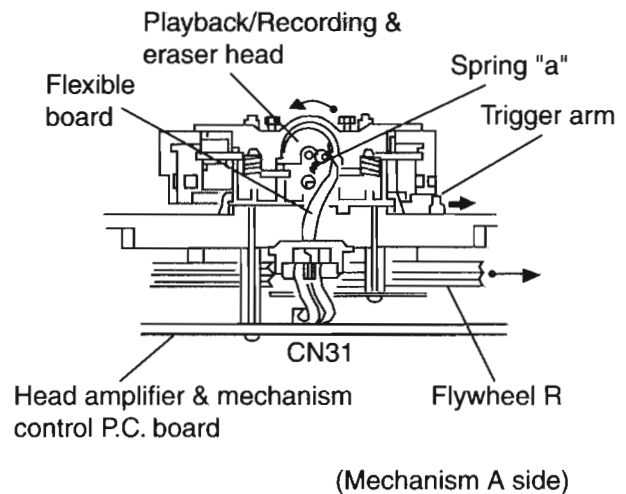
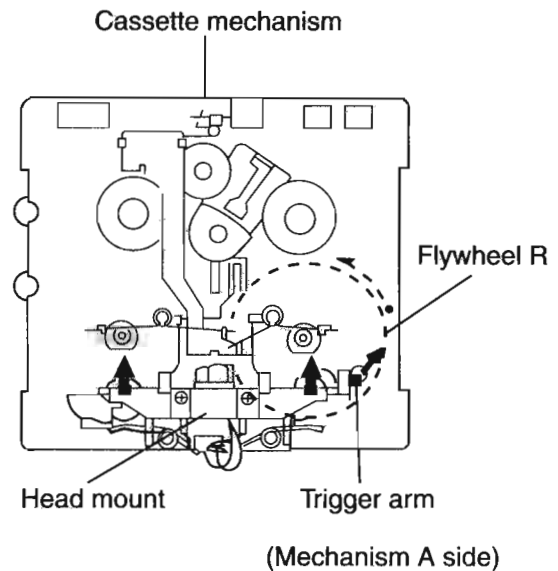

■ Removing the head Amp.and Mechanism Control P.C.Board (See Fig 4)

- 1.Remove the cassette mechanism assembly.
- 2.After turning over the cassette mechanism assembly,remove the five screws "A" retaining the head amp. and mechanism control P.C. board
- 3.Disconnect the connectors CN303 and CN304 on the P.C.Board and the connectors CN1 on both the right and left side reel pulse P.C.Boards.
- 4.When necessary, remove the 4pin parallel wire soldered to the main motor

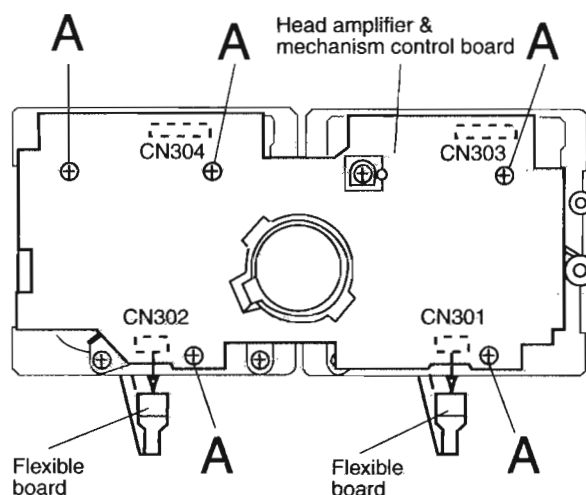

■ Removing the Capstan Motor Assembly

- 1.Remove the six screws "B" retaining capstan motor assembly (See Fig 5).
- 2.While raising the capstan motor, remove the capstan belts A and B respectively from the motor pulley (See Fig 6).

Caution 1: Be sure to handle the capstan belts so carefully that these belts will not be stained by grease and other foreign matter. Moreover, these belts should be hand while referring to the capstan belt hanging method.

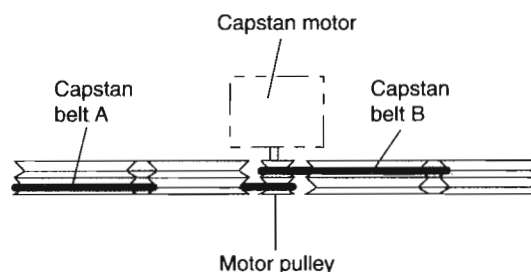
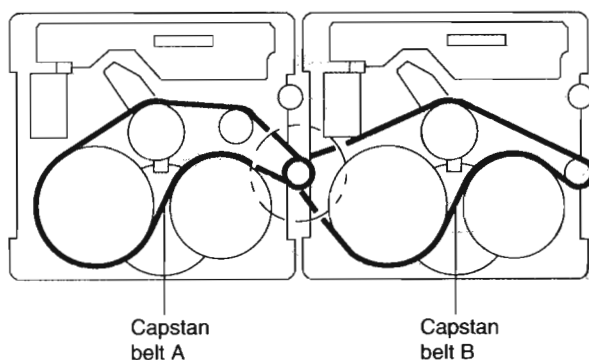
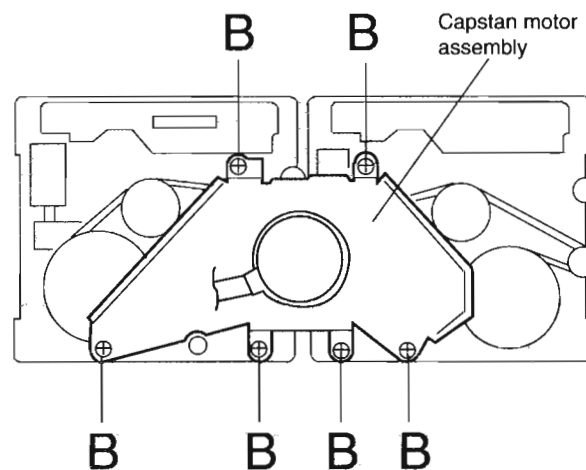

■ **Removing the Capstan Motor (See Fig 8)**

From the joint bracket, remove the two screws "C" retaining the capstan motor.

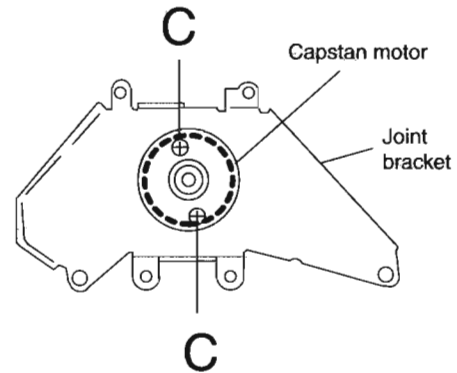

■ **Removing the Flywheel (See Fig 9.10)**

1. Remove the head amp. and mechanism control P.C.Board.
2. Remove the capstan motor assembly.
3. After turning over the cassette mechanism, remove the slit washers "a" and "b" fixing the capstan shafts R and L, and pull out the flywheels R and L respectively from behind the cassette mechanism.

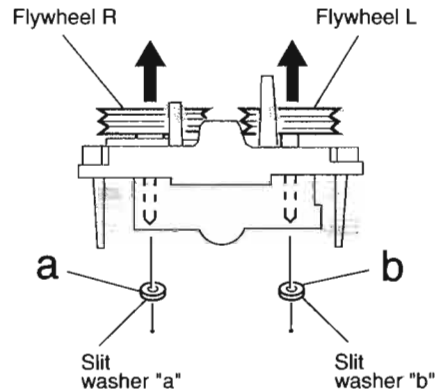
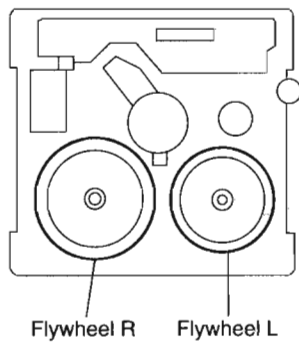

■ **Removing the Reel Pulse P.C.Board and Solenoid (See Fig 11)**

1. Remove the five pawls (c,d,e,f,g) retaining the reel pulse P.C.Board.
2. From the surface of the reel pulse P.C.Board parts, remove the two pawls "h" and "i" retaining the solenoid.

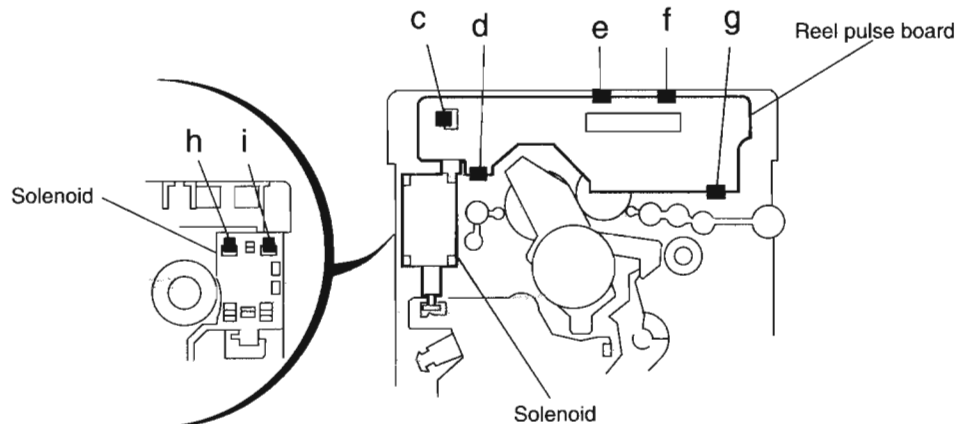

Flow of functional operation until TOC read

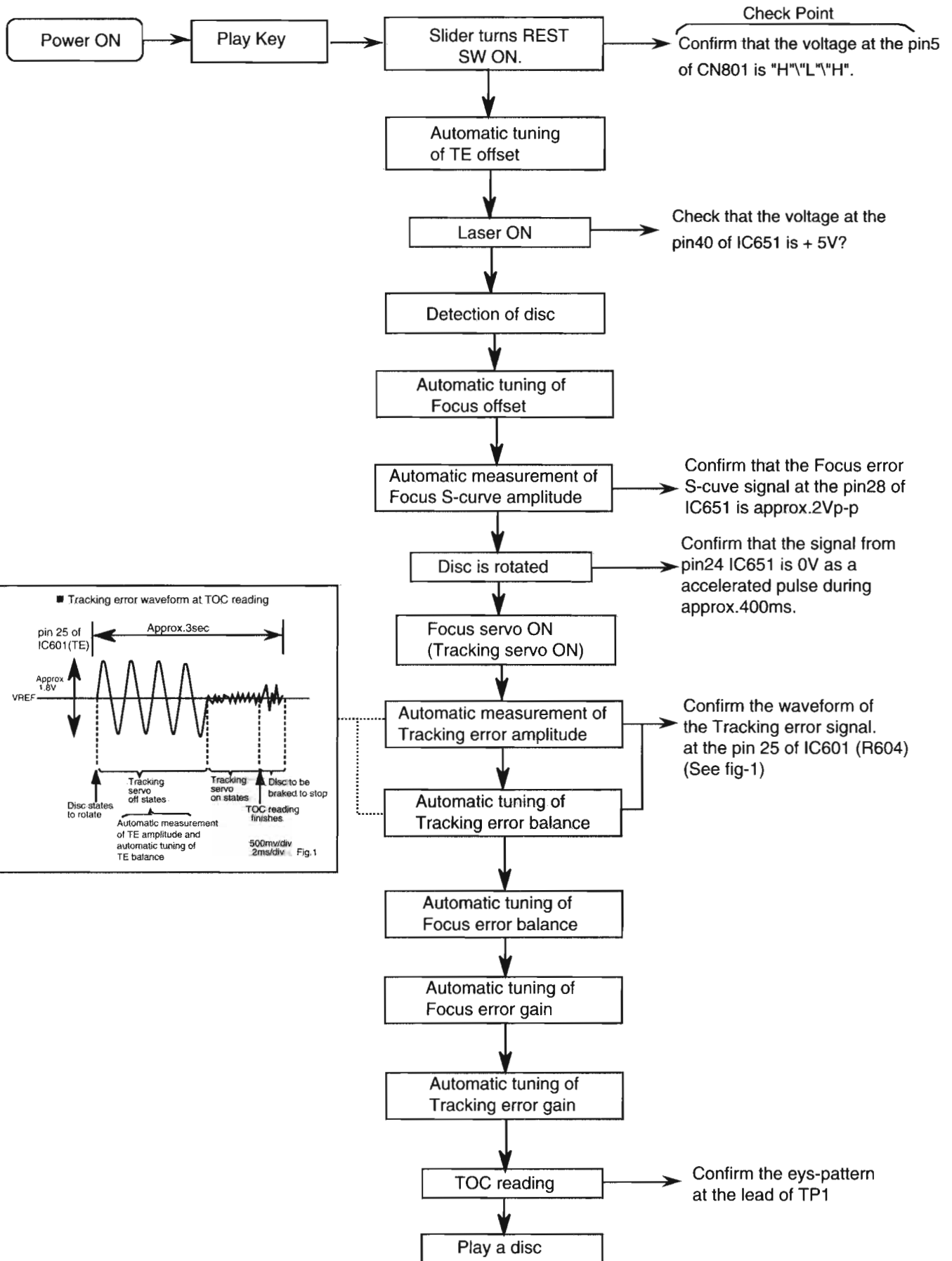

Maintenance of laser pickup

(1) Cleaning the pick up lens

Before you replace the pick up, please try to clean the lens with a alcohol soaked cotton swab.

(2) Life of the laser diode

When the life of the laser diode has expired, the following symptoms will appear.

- (1) The level of RF output (EFM output: amplitude of eye pattern) will below.

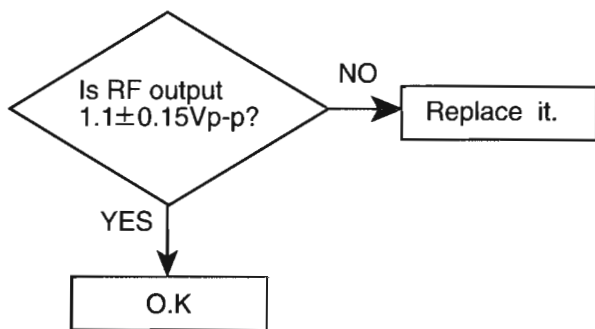

Replacement of laser pickup

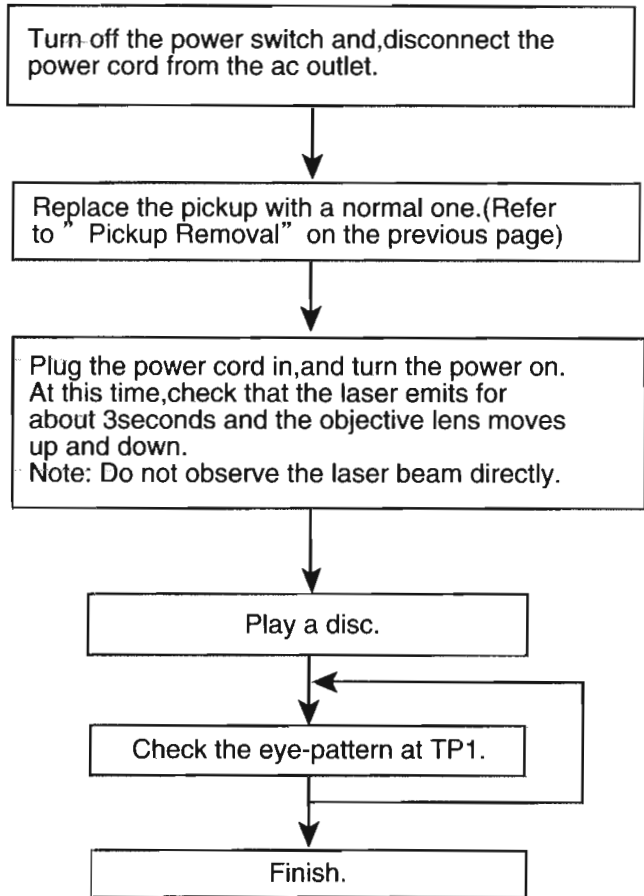

- (3) Semi-fixed resistor on the APC PC board The semi-fixed resistor on the APC printed circuit board which is attached to the pickup is used to adjust the laser power. Since this adjustment should be performed to match the characteristics of the whole optical block, do not touch the semi-fixed resistor. If the laser power is lower than the specified value, the laser diode is almost worn out, and the laser pickup should be replaced. If the semi-fixed resistor is adjusted while the pickup is functioning normally, the laser pickup may be damaged due to excessive current.

Adjustment method

Measurement Instruments Required for Adjustment

1. Low frequency oscillator,
This oscillator should have a capacity to output 0dBs to $600\ \Omega$ at an oscillation frequency of 50Hz-20kHz.
2. Attenuator impedance : $600\ \Omega$
3. Electronic voltmeter
4. Frequency counter
5. Wow flutter meter
6. Test tape
VTT712 : For Tape speed and wow flutter (3kHz)
VTT724 : For Reference level (1kHz)
TMT7036 : For Head angle(10kHz),Play back frequency characteristics(1kHz),and dubbing frequency characteristics(63,1,10kHz)
Because of frequency-mixed tape with 63,1k,10k and 14kHz(250nWb/m -24dB).
Use this tape together with a filter.
7. Blank tape
TAPE I : AC-225, TAPE II : AC-514
8. Torque gauge : For play and back tension
Forward ; TW2111A, Reverse ; TW2121A
Fast Forward and Rewind ; TW2231A
9. Test disc
: CTS-1000(12cm),GRG-1211(8cm)
10. Jitter meter

Measurement Conditions

Power supply voltage
AC230V : (50Hz)

Measurement
output terminal : Speaker out
:TP101(Mesuring for TUNER/DECK/CD)
:Dummy load 6 ohm

Radio input signal

AM modulation frequency : 400Hz
Modulation factor : 30%
FM modulation frequency : 400Hz
Frequency displacement : 22.5kHz

Frequency Range

AM 522kHz~1629kHz
LW 144kHz~288kHz
FM 87.5MHz~108MHz except Ver.EE
65~74/87.5~108MHz only Ver.EE

Standard measurement positions of volume and switch

Power : Standby (Light STANDBY Indicator)
SA-Bass : OFF
Sound mode : OFF
Main VOL. : 0 Minimum
Travers mecha set position : Disc 1

Precautions for Measurement

1. Apply 30pF and $33\text{k}\Omega$ to the IF sweeper output side and $0.082\ \mu\text{F}$ and $100\text{k}\Omega$ in series to the sweeper input side.
2. The IF sweeper output level should be made as low as possible within the adjustable range.
3. Since the IF sweeper is a fixed device, there is no need to adjust this sweeper.
4. Since a ceramic oscillator is used, there is no need to perform any MPX adjustment.
5. Since a fixed coil is used, there is no need to adjust the FM tracking.
6. The input and output earth systems are separated.
In case of simultaneously measuring the voltage in both of the input and output systems with an electronic voltmeter for two channels, therefore, the earth should be connected particularly.
7. In the case of BTL connection amplifier, the minus terminal of speaker is not for earthing. Therefore, be sure not to connect any other earth terminal to this terminal. This system is of an OTL system.

■ Arrangement of Adjusting Positions

Cassette mechanism section (Mechanism A section)

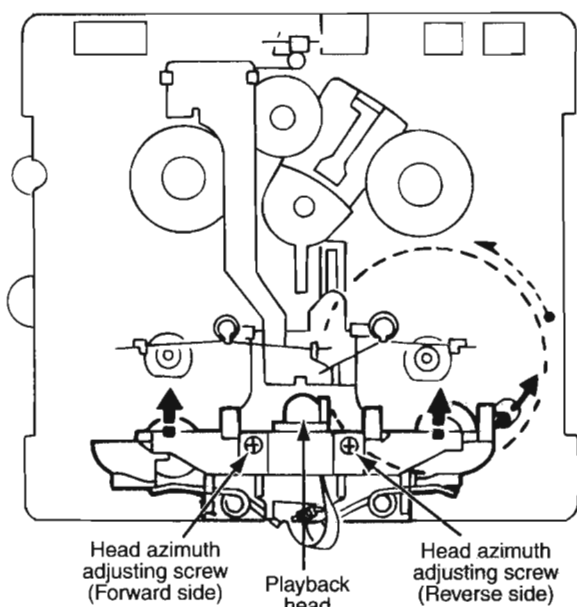

Cassette mechanism section (Back side)

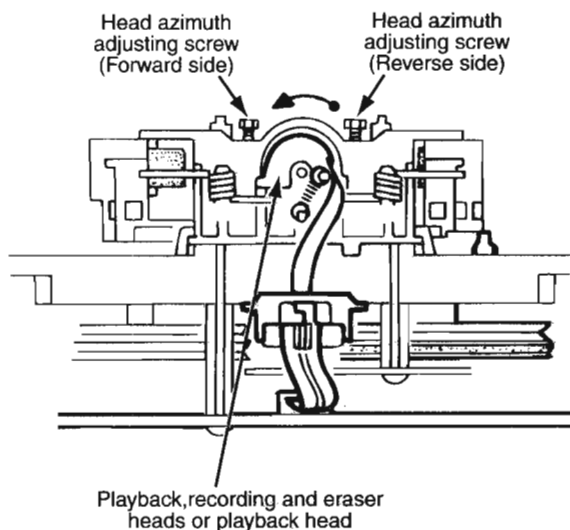

Cassette Mechanism Unit Section

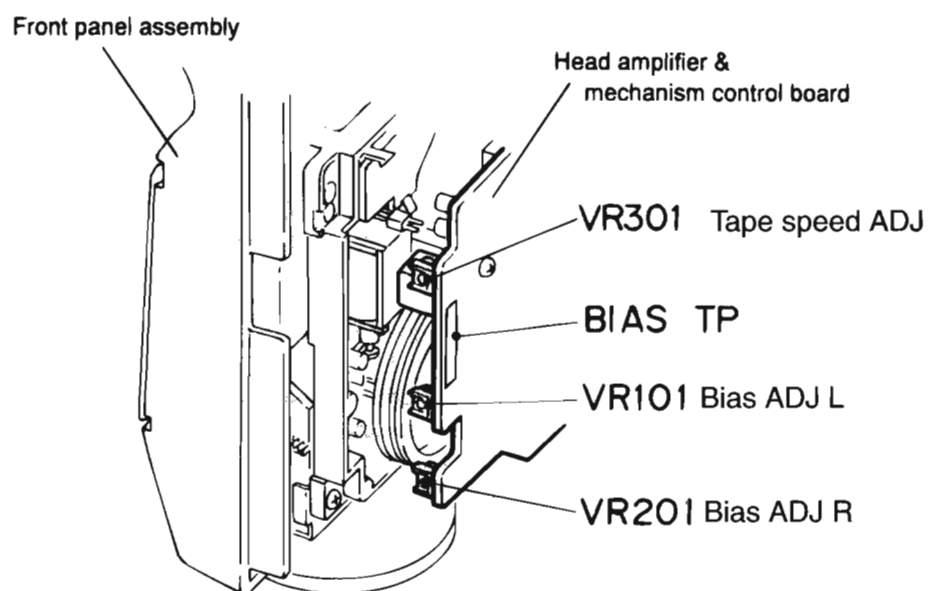

■ Tape Recorder Section

Items	Measurement conditions	Measurement method	Standard values	Adjusting positions
Confirmation of head angle	Test tape :TMT7036(10kHz) Measurement output terminal :Speaker terminal Speaker R (Load resistor:3Ω) :Headphone terminal	1.Playback the test tape TMT7036(10kHz). 2.With the playback mechanism or recording & playback mechanism, adjust the head azimuth screw so that the forward and reverse output levels become maximum.After adjustment,lock the head azimuth at least by half a turn. 3.In either case,this adjustment should be performed in both the forward and reverse directions with the head azimuth screw.	Maximum output	Adjust the head azimuth screw only when the head has been changed.
Confirmation of tape speed	Test tape :VTT712(3kHz) or TMT7036(3kHz) Measurement output terminal :Headphone terminal	<Constant speed> Adjust VR301 so that the frequency counter reading becomes 3,000Hz±60Hz when playing back the test tape VTT712(3kHz)with the playback mechanism or playback and recording mechanism after ending forward winding of the tape.	Tape speed of decks (A and B) :3,000Hz ±60Hz	VR301

■ Reference Values for Confirmation items

Items	Measurement conditions	Measurement method	Standard values	Adjusting positions
Double tape speed	Test tape :TMT7036(10kHz) Measurement output terminal :Speaker terminal Speaker R (Load resistance:3Ω) measurement output terminal :Headphone terminal	After setting to the double speed motor, confirm that the frequency counter reading becomes 4,800+400/-300Hz when the test tape VTT712 (3kHz) has been play back with the playback mechanism.	4,800+400/-300Hz	Playback mechanism side
Difference between the forward and reverse speed. P.mecha and R/P mecha speed		When the test tape VTT712(3kHz) has been played back with the playback mechanism or recording and playback mechanism at the beginning of forward winding, the frequency counter reading of the difference between both of the mechanisms should be 6.0Hz or less.	60Hz or less	Both the playback and recording & playback mechanism
Wow & flutter	Test tape :TMT7036(10kHz) Measurement output terminal :Headphone terminal	When the test tape VTT712(3kHz) has been played back with the playback mechanism or recording and playback mechanism at the beginning of forward winding the frequency counter reading of wow & flutter should be 0.25% or less(WRMS).	with in 0.25% JIS(WTD)	Both the playback and recording & playback mechanism

■ Electrical Performance

Items	Measurement conditions	Measurement method	Standard values	Adjusting positions
Adjustment of recording bias current (Reference value)	*Mode : Forward or reverse mode *Recording mode *Test tape : AC-514 and AC-225 Measurement output terminal : Both recording and headphone terminals	1. With the recording and playback mechanism, load the test tapes (AC-514 to TYP II and AC-225 to TYP I), and set the mechanism to the recording and pausing conditions in advance. 2. After connecting 100Ω in series to the recorder head, measure the bias current with a valve voltmeter at both of the terminals. 3. After resetting the [PAUSE] mode, start recording. At this time, adjust VR101 for LcH and VR201 for RcH so that the recording bias current values become $4.0\mu A$ (TYP I) and $4.20\mu A$ (TYP II).	AC-225 : $4.20\mu A$ AC-514 : $4.0\mu A$	LcH : VR101 RcH : VR201
Adjustment of recording and playback frequency characteristics	Reference frequency : 1kHz and 10kHz (REF: -20dB) Test tape : TYP II AC-514 Measurement input terminal : OSC IN	1. With the recording and playback mechanism, load the test tape (AC-514 to TYP II), and set the mechanism to the recording and pausing condition in advance. 2. While repetitively inputting the reference frequency signal of 1kHz and 10kHz from OSC IN, record and playback the test tape. 3. While recording and playing back the test tape in TYP II, adjust VR101 for LcH and VR201 for RcH so that the output deviation between 1kHz and 10kHz becomes $-1dB \pm 2dB$.	Output deviation between 1kHz and 10kHz : $-1dB \pm 2dB$	LcH : VR101 RcH : VR201

■ Reference Values for Electrical Function Confirmation Items

Items	Measurement conditions	Measurement method	Standard values	Adjusting positions
Recording bias frequency	*Recording and playback side forward or reverse *Test tape : TYP II AC-514 *Measurement terminal BIAS TP on P.C. board	1. While changing over to and from BIAS 1 and 2, confirm that the frequency is changed. 2. With the recording and playback mechanism, load the test tape (AC-514 to TYP II), and set the mechanism to the recording and pausing conditions in advance. 3. Confirm that the BIAS TP frequency on the P.C. board is $100kHz \pm 6kHz$.	100kHz +9kHz -7kHz	
Eraser current (Reference value)	*Recording and playback side forward or reverse *Recording mode *Test tape : AC-514 and AC-225 Measurement terminal : Both of the eraser head	1. With the recording and playback mechanism, load the test tapes (AC-514 to TYP II and AC-225 to TYP I), and set the mechanism to the recording and pausing condition in advance. 2. After setting to the recording conditions, connect $1M\Omega$ in series to the eraser head on the recording and playback mechanism side, and measure the eraser current from both of the eraser terminal.	TYP II : 120mA TYP I : 75mA	

Diagnosis which uses extension wire method

CD Changer mechanism

- 1.Remove the top cover and CD changer mechanism.
- 2.The extension wire "A" is connected with CN651 and CN410.

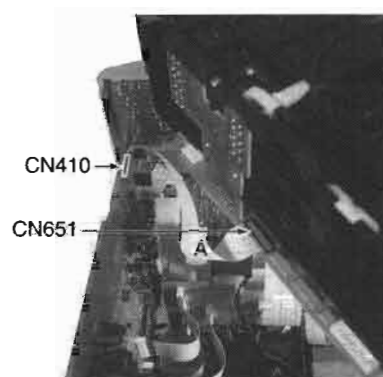

System control P.C.board

- 1.Remove the top cover and CD changer mechanism.
- 2.Remove the front panel assembly.
- 3.Disconnect the card wire "B", "C", "D".
- 4.The 1pin wire is removed from D851
- 5.Six screws "E" are removed, and the bracket is removed.
- 6.Two screws "F" on the system control P.C.board are removed, and the system control P.C.board is knocked down forward.
- 7.The flat wire "G" is connected with CN703 on the Power AMP.P.C.board while remove flat wire "G" from the hook, and extended.
- 8.Two extension wires "H" are connected with CN860, CN412, and CN862, CN411 respectively.
- 9.The extension wire "I" is connected with CN861 and CN413.
- 10.The extension wire "J" is connected with CN856 and CN810.
- 11.The extension wire "K" is connected with CN857 and CN811.
- 12.The extension wire "L" is connected with CN306 and CN812.

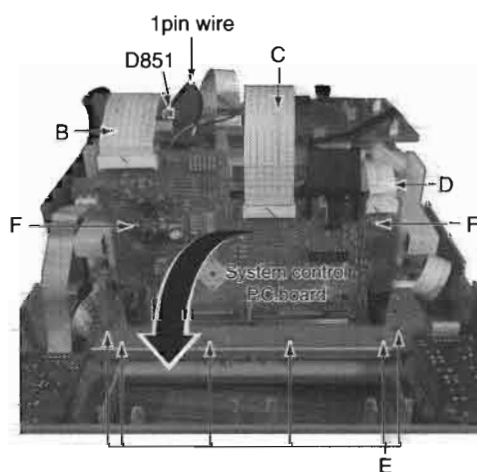

Extension wire parts No.

- A : VWF1019-45TTA
- H : QUQ412-2140CJ
- I : QUQ412-1738CJ
- J : QUQ412-2120CJ
- K : VWF1223-30TTB
- L : VWF1211-28TTB

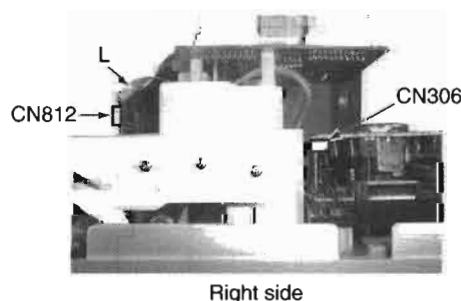
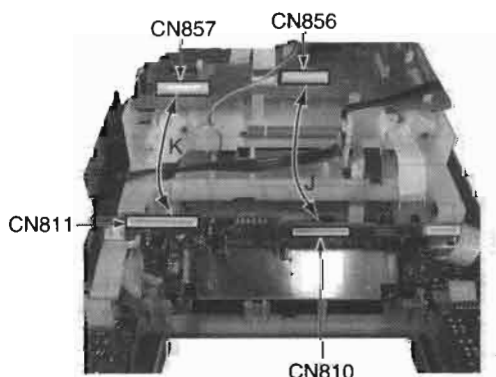
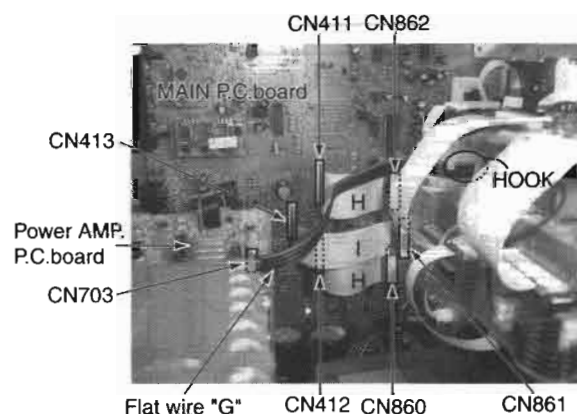

Schematic Diagrams

Power Transformer Section

POWER SUPPLY BLOCK

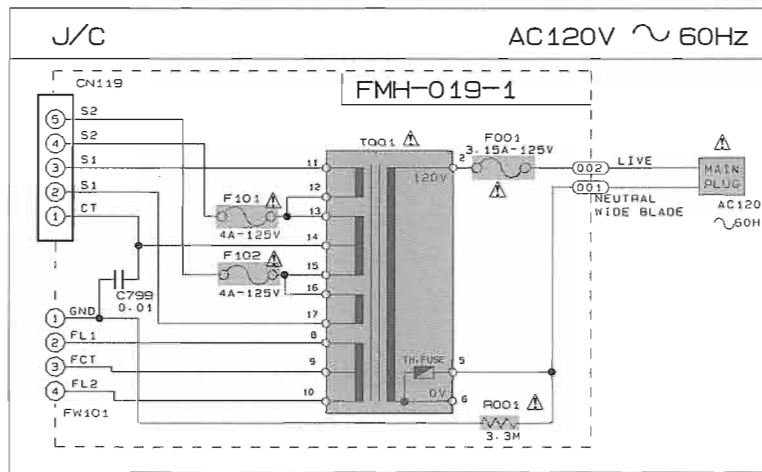

POWER SUPPLY BLOCK

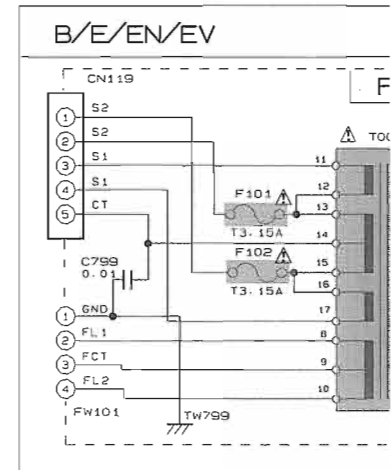

POWER SUPPLY BLOCK

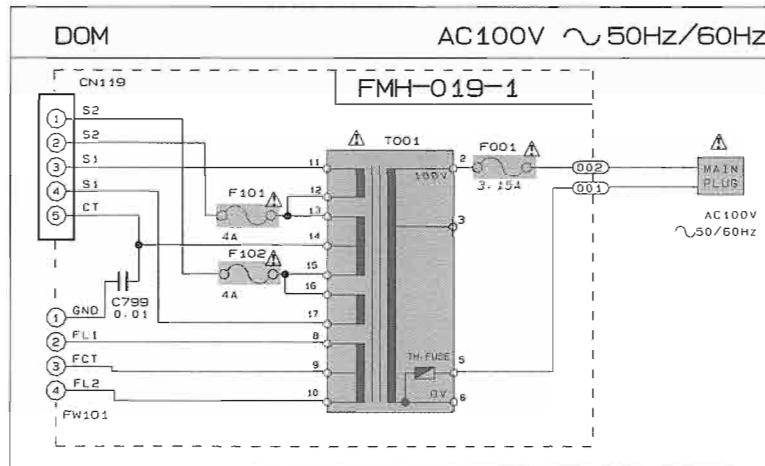

POWER SUPPLY BLOCK

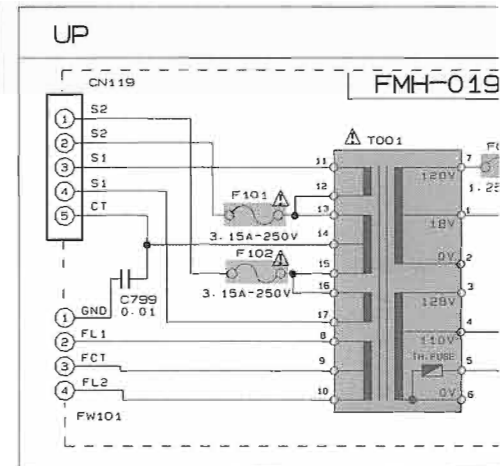

POWER SUPPLY BLOCK

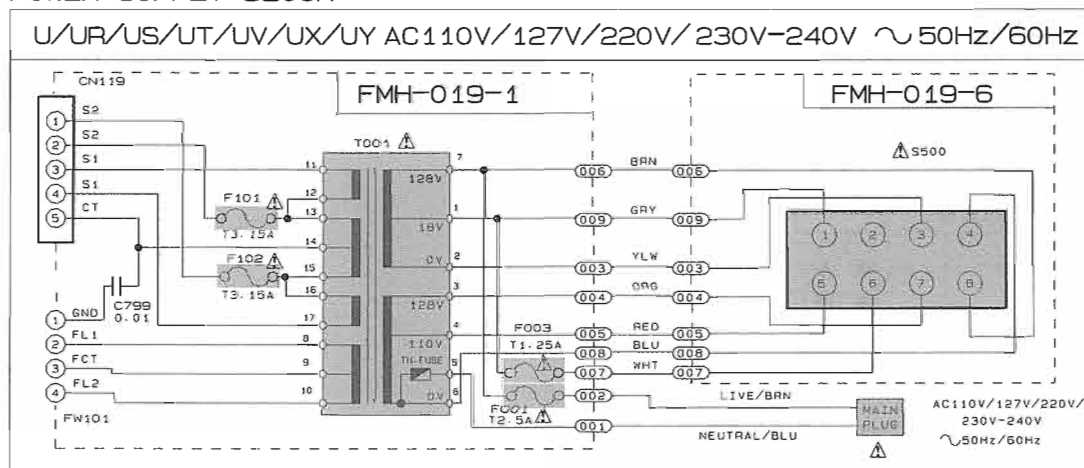

VOLTAGE SELECTOR LOCATION

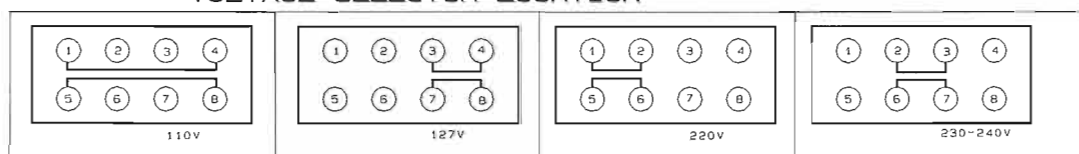

SHEET NUMBER	REV	DESCRIPTION
1/11		MX-J50/C CA-MXJ55R/MX-
2/11		MX-J50/C CA-MXJ55R/MX-
3/11		MX-J50/C CA-MXJ55R/MX-
4/11		MX-J50/MX-J
5/11		CA-MXJ55R/C
6/11		MX-J5
7/11		MX-J5
8/11		MX-J50/C CA-MXJ55R/MX-
9/11		MX-J5
10/11		MX-J50/C CA-MXJ55R/MX-
11/11		MX-J50/C CA-MXJ55R/MX-

NOTES: MARK [*] IS DETAILS ARE

A

B

C

D

E

JK

POWER SUPPLY BLOCK

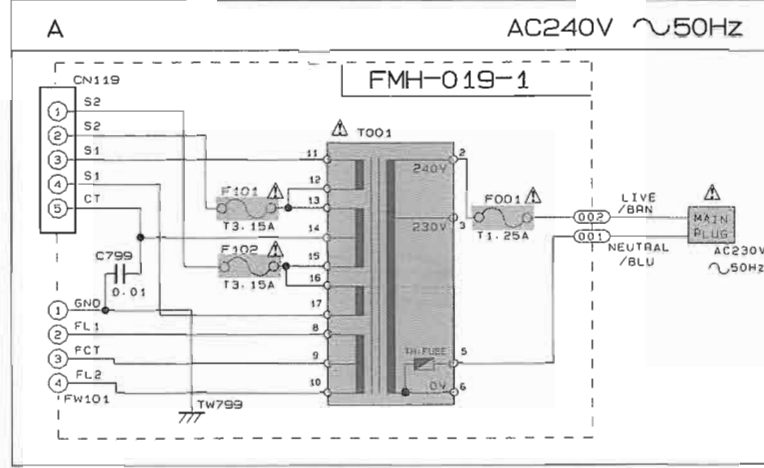
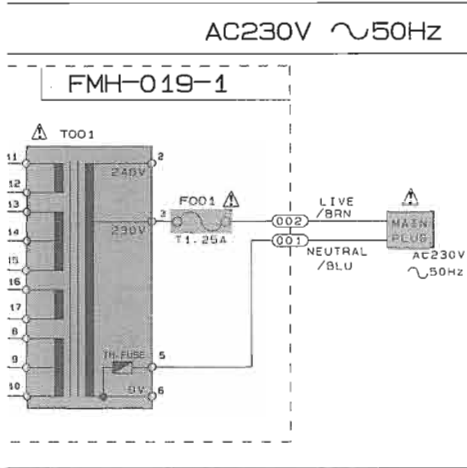

POWER SUPPLY BLOCK

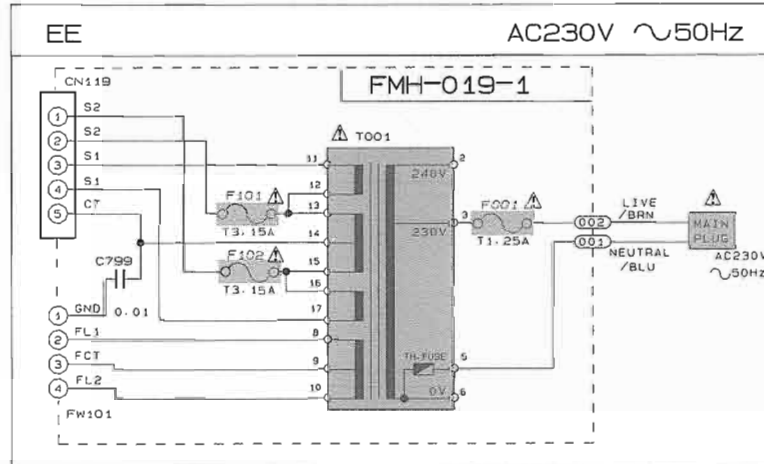
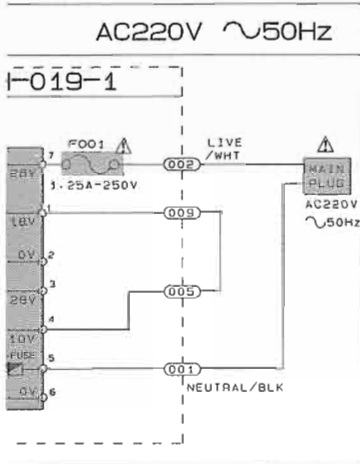

MODEL NUMBERS TO BE APPLIED	CIRCUITS DESCRIPTION
MX-J50/CA-MXJ50/MX-J56 J55R/MX-J55R/CA-MXJ530R	. PRIMARY WITH MAINS TRANSFORMER
MX-J50/CA-MXJ50/MX-J56 J55R/MX-J55R/CA-MXJ530R	. DC REGULATORS/AUDIO OUTPUT
MX-J50/CA-MXJ50/MX-J56 J55R/MX-J55R/CA-MXJ530R	. EXTERNAL INPUT. SOURCE SELECTOR SWITCH
J50/MX-J56/CA-MXJ50	. TUNER RF/IF/FM MULTIPLEX (ONLY FOR J. C. U. UP. UR. US. UT. UV. UX. UY. A. DOM)
MXJ55R/CA-MXJ530R	. TUNER RF/IF/FM MULTIPLEX (ONLY FOR B. E. EN. EV)
MX-J55R	. TUNER RF/IF/FM MULTIPLEX (ONLY FOR EE)
MX-J55R	. POLAR STEREO MULTIPLEX (ONLY FOR EE)
MX-J50/CA-MXJ50/MX-J56 J55R/MX-J55R/CA-MXJ530R	. FL DISPLAY. SYSTEM CONTROL LSI. USER CONTROL KEYS
MX-J50	. MIC AMP. ECHO CIRCUIT (ONLY FOR U/UP/UR/US/UT/UV/UX/UY)
MX-J50/CA-MXJ50/MX-J56 J55R/MX-J55R/CA-MXJ530R	. TAPE DECK MECHANISM CONTROL . TAPE CIRCUITS SUCH AS PRE-AMP AND BIAS
MX-J50/CA-MXJ50/MX-J56 J55R/MX-J55R/CA-MXJ530R	. CD SERVO AND CD SYSTEM CONTROL . CD CHANGER MECHANISM CONTROL

(*) IS TO SHOW DEVIATION IN VERSIONS.
VLS ARE EXPLAINED NEAR THE MARK.

MODEL
MX-J50/CA-MXJ50/CA-MXJ55R
CA-MXJ530R/MX-J55R/MX-J56

9/EET
1/11

Parts are safety assurance parts.
When replacing those parts make
sure to use the specified one.

E

F

G

H

I

EET 6/11)

10 CN652 CF FMB-***-B

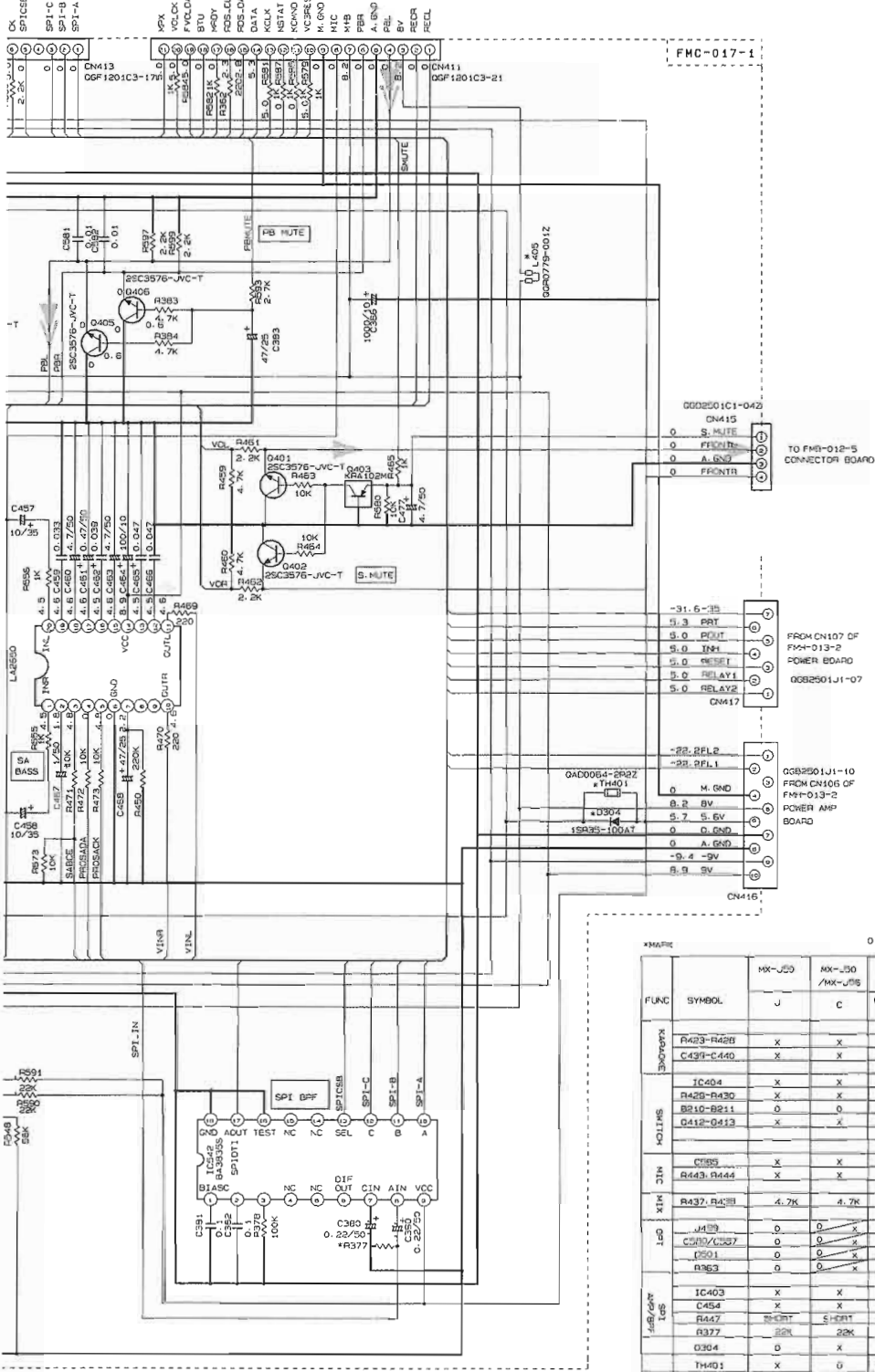

*PARTS O USED X NONE

FUNC	SYMBOL	MX-J55		MX-J50		CA-MXJ530R		CA-MXJ55R	
		J	C	U-LS, LP UT, UB	A	B, E, EN, EV	EE	DOH	
KOLIMS	R423-R426	X	X	0	X	X	X	X	X
	C439-C440	X	X	0	X	X	X	X	X
	IC404	X	X	0	X	X	X	X	X
	R429-R430	X	X	0	X	X	X	X	X
KOLIMS	B210-B211	0	0	X	0	0	0	0	0
	Q412-Q413	X	X	0	X	X	X	X	X
	C385	X	X	0	X	X	X	X	X
	R443, R444	X	X	0	X	X	X	X	X
KOLIMS	R437, R438	4.7K	4.7K	6.8K	4.7K	4.7K	4.7K	4.7K	4.7K
	J409	0	0	X	0	0	0	0	0
	C380/C387	0	0	X	0	0	0	0	0
	B201	0	0	X	0	0	0	0	0
KOLIMS	R463	0	0	X	0	0	0	0	0
	IC403	X	X	0	X	X	X	X	X
	C454	X	X	0	X	X	X	X	X
	R447	SHORT	SHORT	0	SHORT	SHORT	SHORT	SHORT	SHORT
KOLIMS	R377	22K	22K	10K	22K	22K	22K	22K	22K
	Q304	0	X	X	X	X	X	X	X
	TH401	X	0	0	0	0	0	0	0
	L405	0	0	0	0	0	SHORT	0	0
KOLIMS	L403	0	0	0	0	0	SHORT	0	0
	L404	SHORT	SHORT	SHORT	0	0	SHORT	SHORT	SHORT
	L405	SHORT	SHORT	SHORT	0	0	SHORT	SHORT	SHORT
	R359	X	X	X	0	0	0	0	0
KOLIMS	C453, C455	X	X	X	0	0	X	X	X
	C484	100P	100P	1000P	0.0022	0.0022	100P	100P	100P
	C398-C399	0	0	0	0	0	X	0	0
	C583	X	X	X	0	0	X	X	X
KOLIMS	C584	X	X	X	0	0	X	X	X

CD / MAIN SIGNAL
 TUNER SIGNAL
 TAPE P.B. SIGNAL

MODEL MX-J55
 MODEL MX-J50
 MODEL MX-J53R
 MODEL CA-MXJ530R
 MODEL CA-MXJ55R
 MODEL CA-MXJ50

9-CCT
 3/11

TUNER Section (For Ver. B,E,EN,EV)

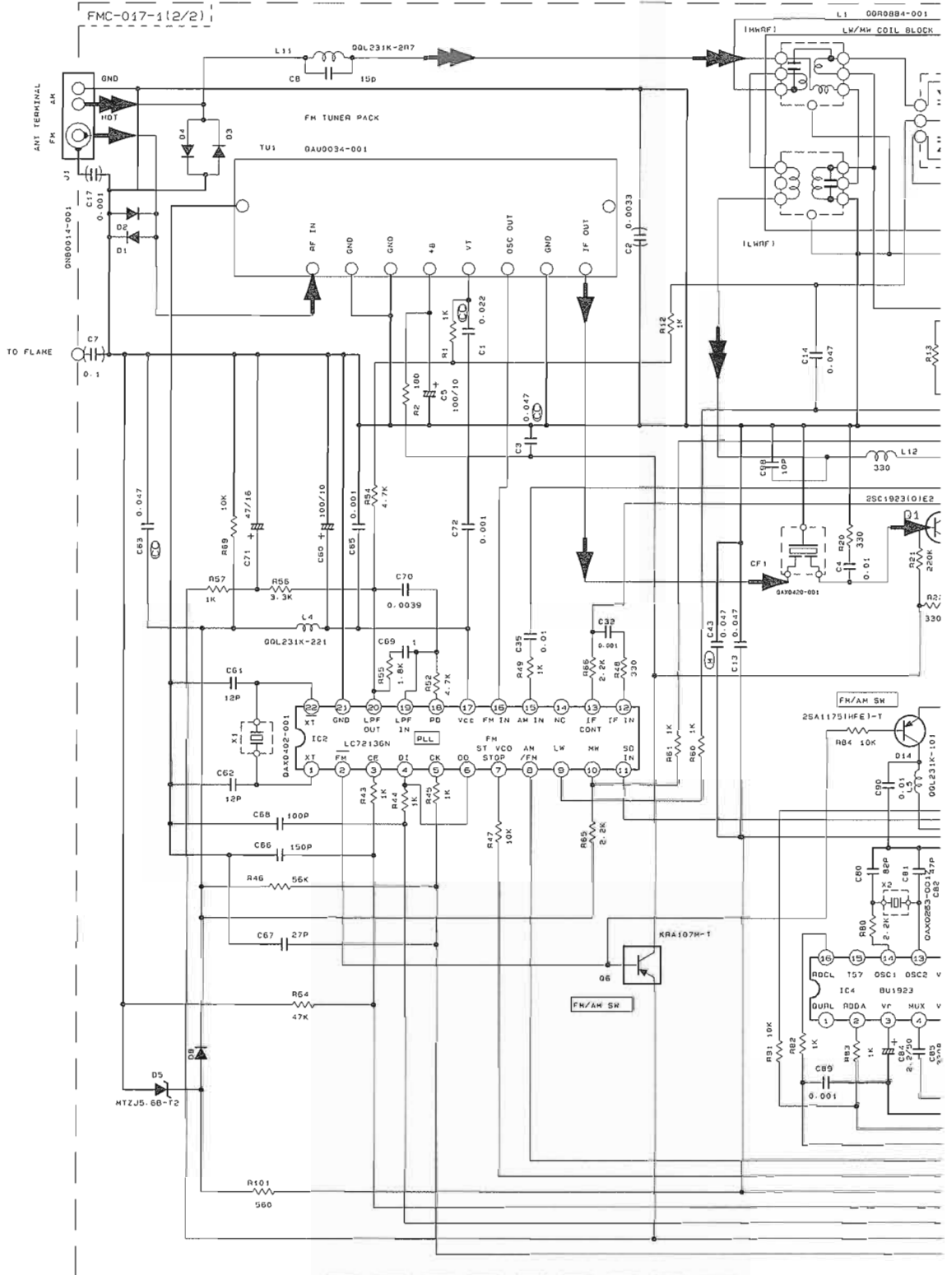

CONDITION	PIN NO.	1	2	3	4	5	6	7	8	9	10	11	12	13	14	15	16	17	18	19	20	21	22	23	24	25	26	27	28	29
IC1	FM NO SIGNAL	3-5	9-1	3-5	3-5	0-4	7-0	5-4	9-1	0	1-3	0-3	0-5	0-6	0	0	4-3	4-3	4-3	4-3	1-2	3-2	2-0	3-5	0	0	3-4	3-4	3-6	3-6
	FM GOOD STEREO	3-5	9-1	3-5	3-5	0	0	0-2	9-1	2-3	1-3	4-3	0	0-6	0	0	4-3	4-3	4-3	4-3	1-2	3-2	2-0	3-1	0	0	3-5	3-6	3-6	3-6
	AM NO SIGNAL	3-3	9-1	3-5	3-5	0	9-1	5-4	9-1	2-7	1-3	0	0	0-0	0-1	5-6	4-2	4-2	4-2	4-2	1-2	3-2	2-8	2-9	0-6	0-5	3-3	3-5	3-3	3-3
IC2	FM NO SIGNAL	2-4	0	0	5-6	4-9	5-6	0	0	3-1	3-8	0-4	0	0	0	0	2-4	4-9	0-7	0-7	7-2	0	2-6							

A B C D E

CA-MXJ55R/CA-MXJ530R

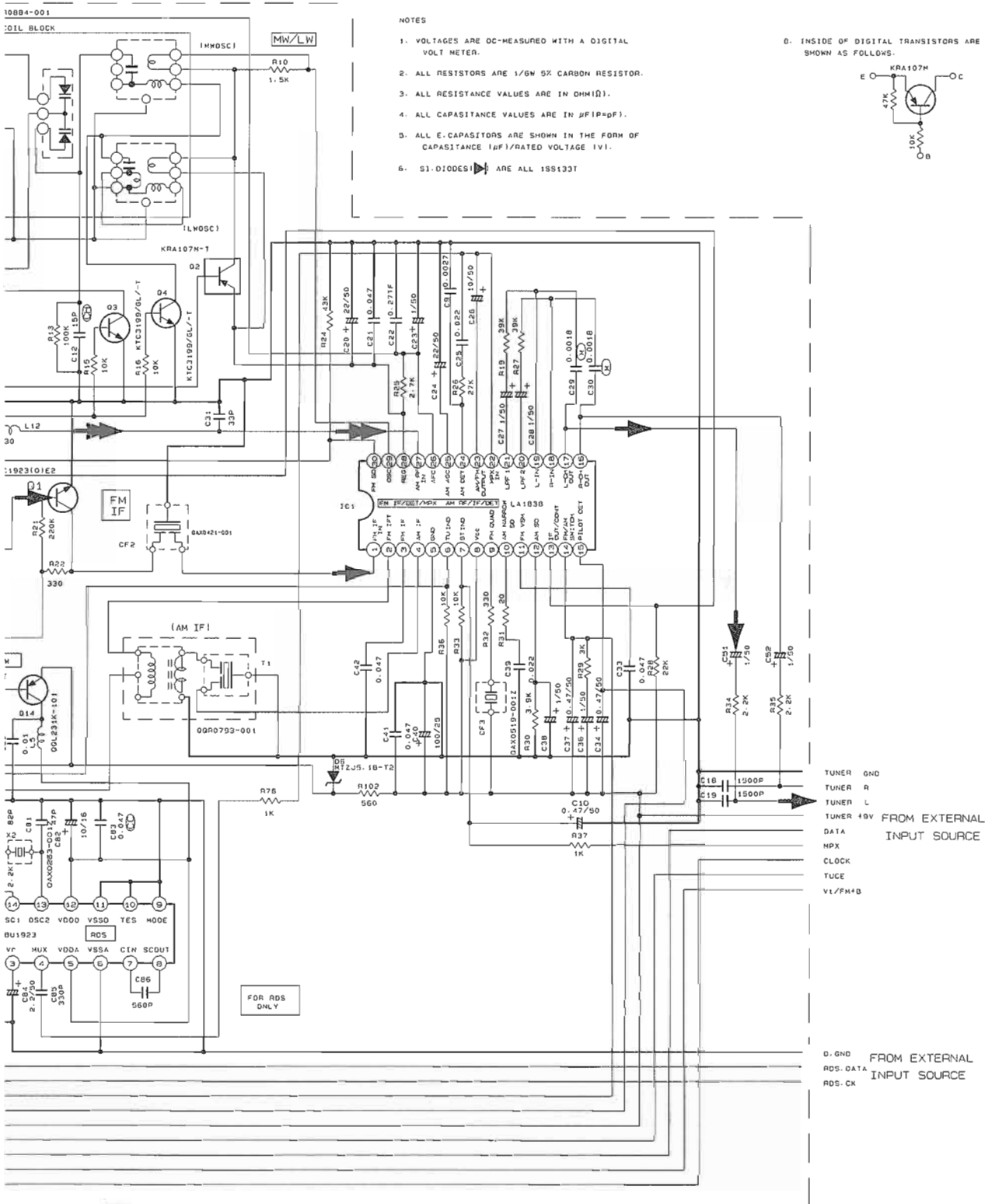

- NOTES
1. VOLTAGES ARE DC-MEASURED WITH A DIGITAL VOLT METER.
 2. ALL RESISTORS ARE 1/6W 5% CARBON RESISTOR.
 3. ALL RESISTANCE VALUES ARE IN OHM(Ω).
 4. ALL CAPACITANCE VALUES ARE IN μF(μF).
 5. ALL E. CAPACITORS ARE SHOWN IN THE FORM OF CAPACITANCE (μF)/RATED VOLTAGE (V).
 6. S1-DIODES ARE ALL 1SS133T

6. INSIDE OF DIGITAL TRANSISTORS ARE SHOWN AS FOLLOWS.

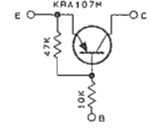

Tr. NO.			01			06		
PIN NO.			E	C	B	E	C	B
20	29	30	0	7.4	0.6	0.4	0.3	0
3.6	3.5	2.3	0	0	0	0.5	0	0.4
Tr. NO.			02			04		
PIN NO.			E	C	B	E	C	B
3.6	3.5	2.3	3.5	3.5	0.3	0	0	0.7
3.5	3.5	2.1	3.5	3.5	3.5	0	0	0.1

B/E/EN/EV
 MODEL CA-MXJ530R SHEET 5/11
 CA-MXJ55R

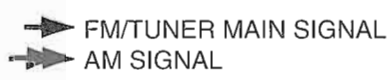

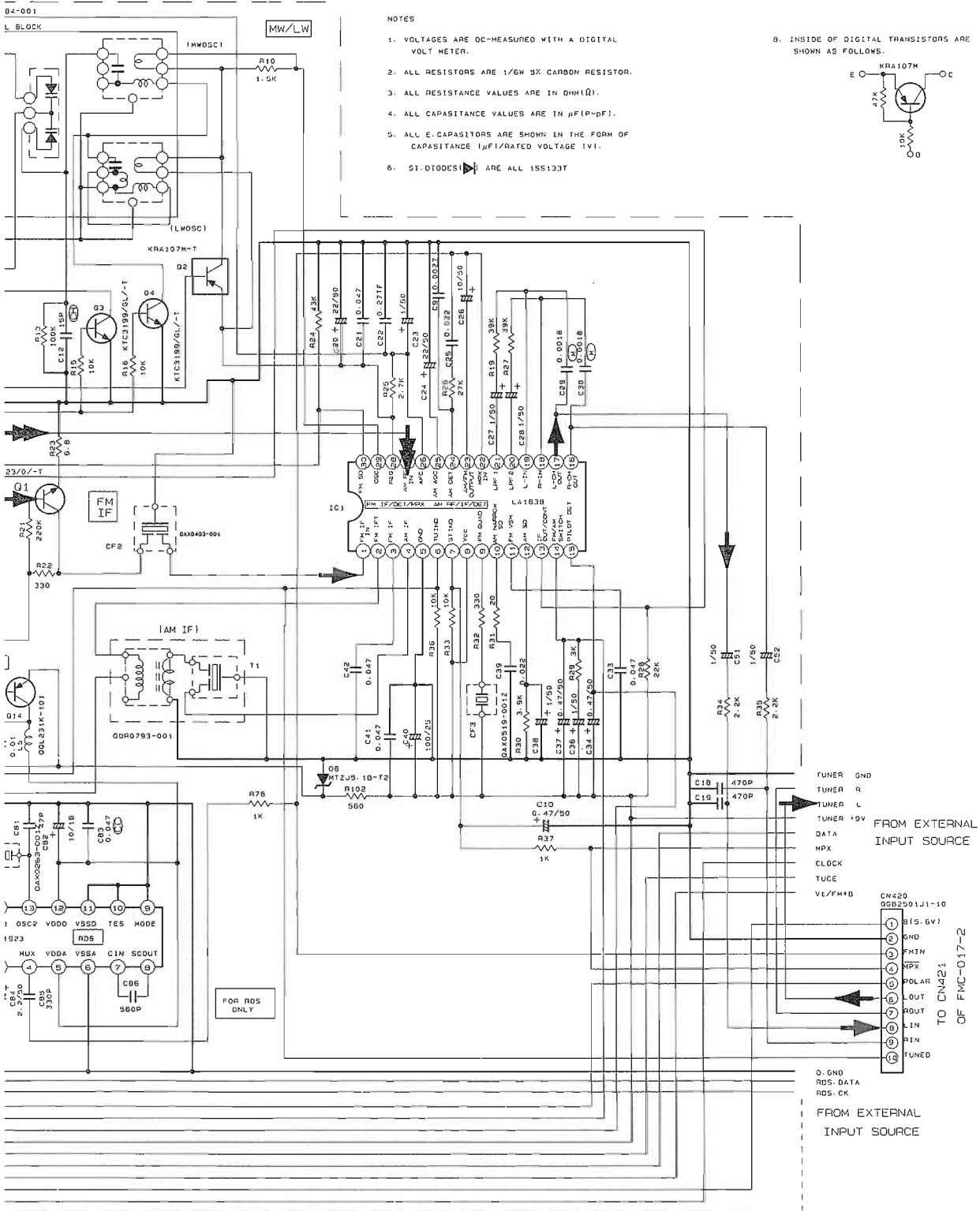

- NOTES
1. VOLTAGES ARE DC-MEASURED WITH A DIGITAL VOLT METER.
 2. ALL RESISTORS ARE 1/6W 5% CARBON RESISTOR.
 3. ALL RESISTANCE VALUES ARE IN OHM(Ω).
 4. ALL CAPACITANCE VALUES ARE IN μ F(μ -pF).
 5. ALL E. CAPACITORS ARE SHOWN IN THE FORM OF CAPACITANCE μ F/RATED VOLTAGE (V).
 6. SI-DIODES \blacktriangleright ARE ALL 1SS133T

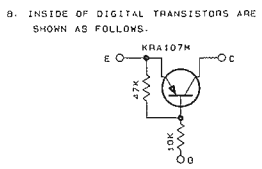

EE
MODEL:MX-J55R
MX-J75R

SHEET
6/11

Tr NO.	G1			G6			G4		
PIN NO.	E	C	B	E	C	B	E	C	B
FM 87.5MHz NO SIGNAL	0	7.4	0.8	6.4	6.3	0			
AM 522kHz NO SIGNAL	0	0	0	6.5	0	6.4			
Tr NO.	G2			G3			G4		
PIN NO.	E	C	B	E	C	B	E	C	B
AM 522kHz NO SIGNAL	3.5	3.5	0.3	0	0	0.7	0	0	0.7
AM 144kHz NO SIGNAL	3.5	3.5	3.5	0	0	0.1	0	0	0.1

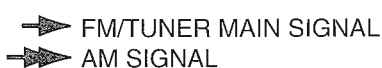

■ POLAR Section (For Ver. EE)

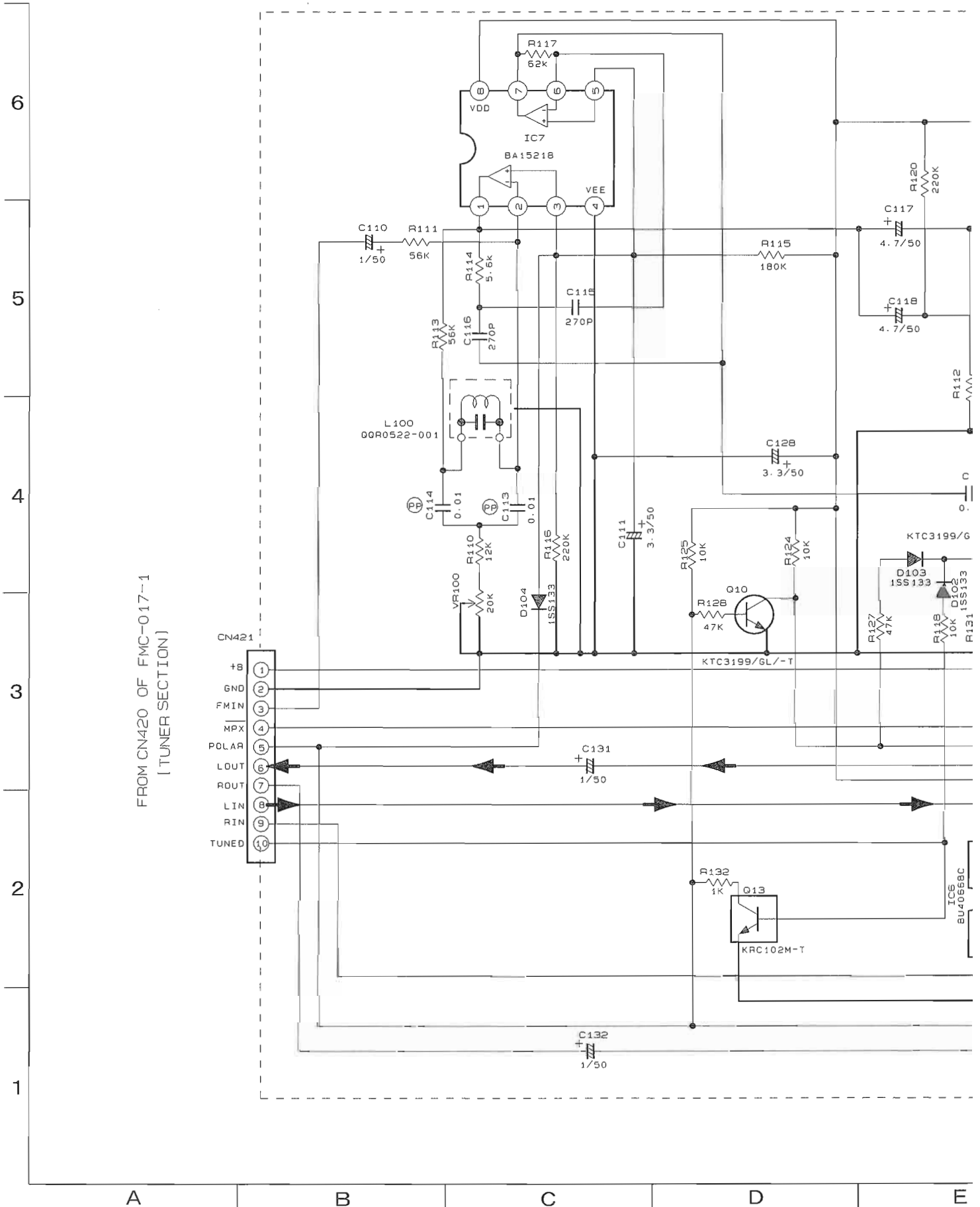

FROM CN420 OF FMC-017-1
(TUNER SECTION)

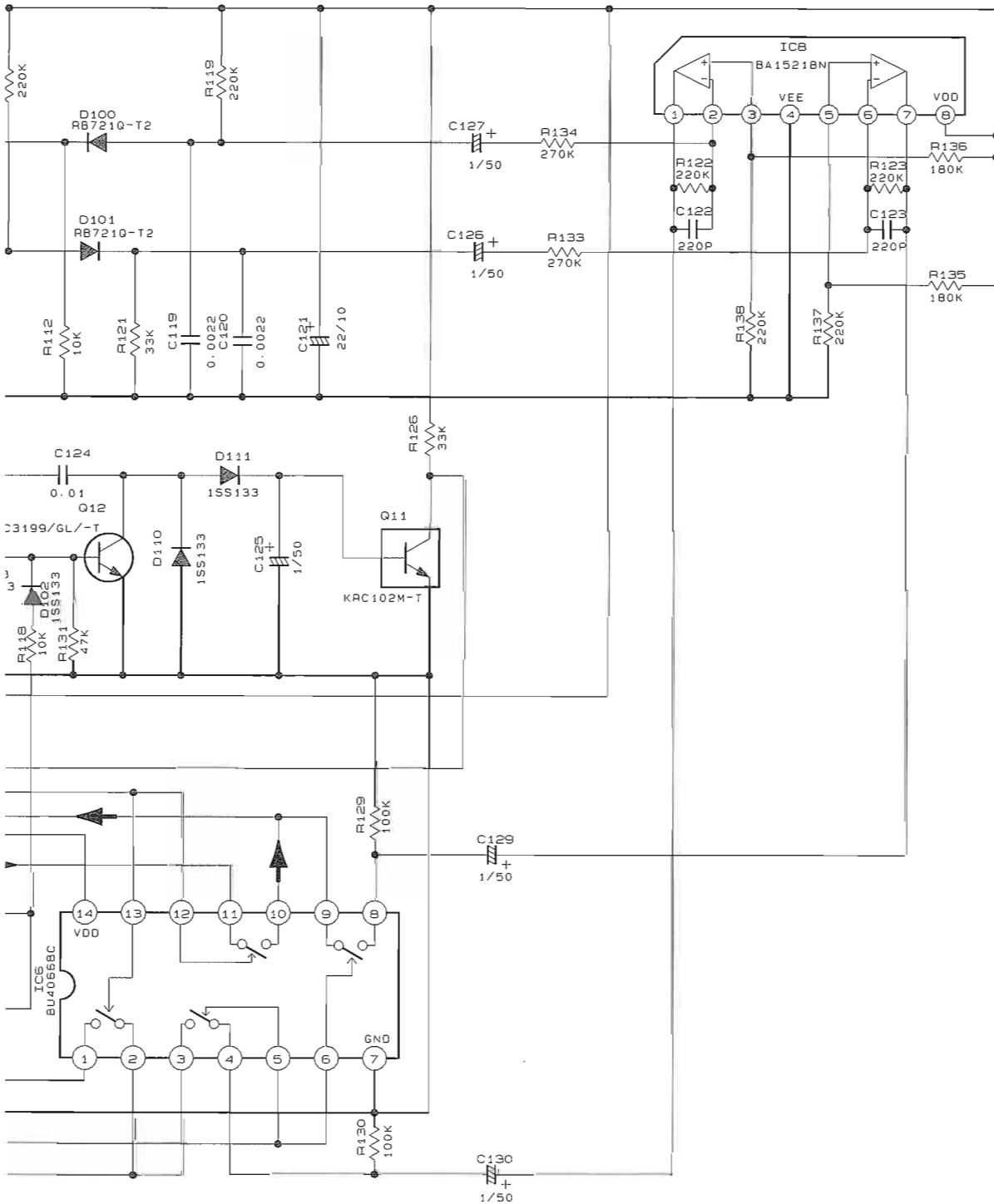

➔ TUNER MAIN SIGNAL

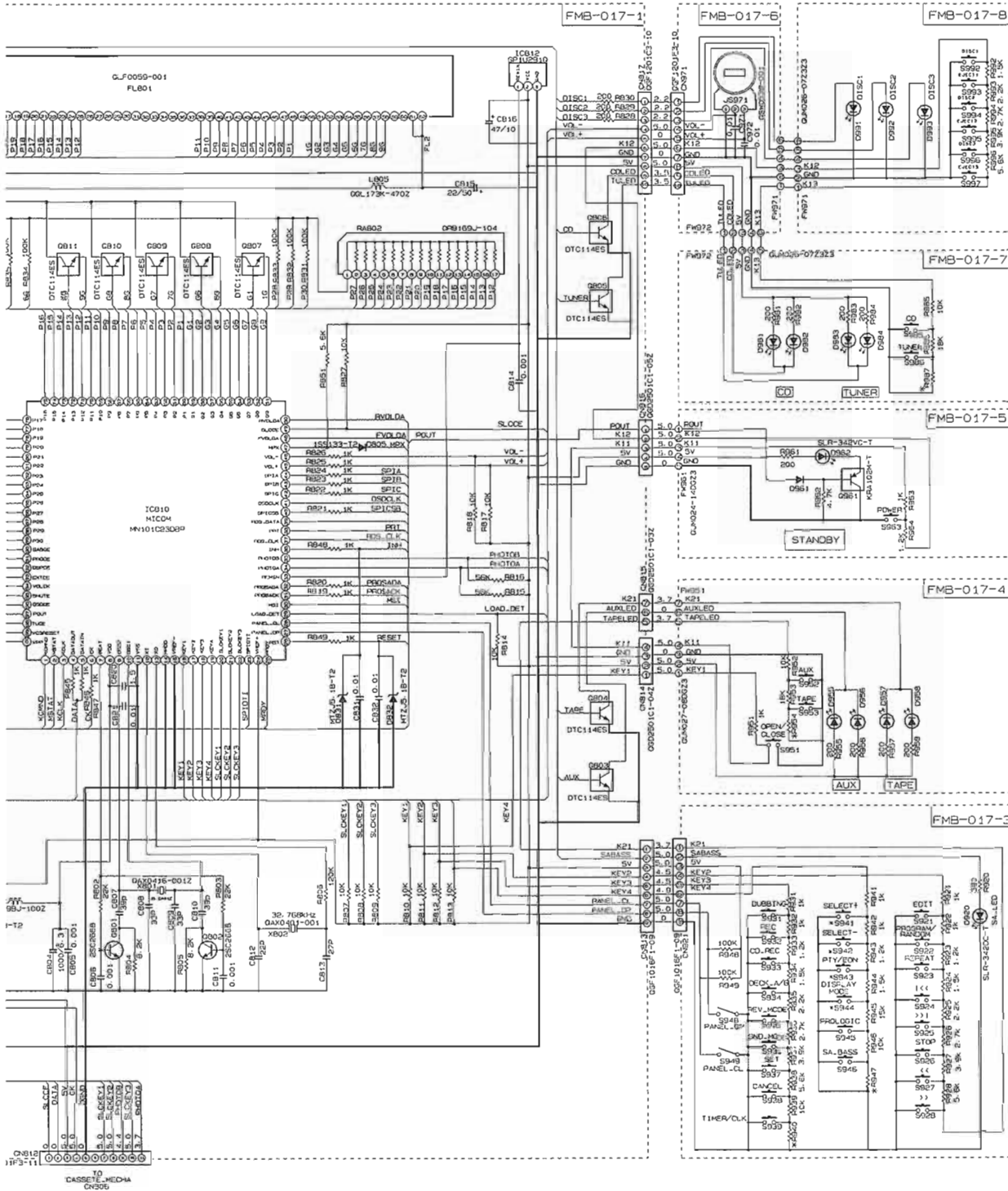

NOTES

- VOLTAGES ARE DC-MEASURED WITH A DIGITAL VOLT METER OR OSCILLOSCOPE WITHOUT INPUT SIGNAL. CONDITION --- 100% P.D. MODE.
- UNLESS OTHERWISE SPECIFIED: RESISTORS ARE 1/4W, 5% OHM TOLERANCE. ALL CAPACITORS ARE ELECTRIC DOUBLE LAYER CAPACITORS. ALL CAPACITANCE VALUES ARE IN pF UNLESS OTHERWISE SPECIFIED. ALL INDUCTIVE VALUES ARE IN mH UNLESS OTHERWISE SPECIFIED. ALL DIMENSIONS ARE GIVEN IN mm UNLESS OTHERWISE SPECIFIED.
- ALL I.C. PACKAGES ARE 8-PIN DIP UNLESS OTHERWISE SPECIFIED.
- ALL LEADS ARE SMD-3420-1 UNLESS OTHERWISE SPECIFIED.

MX-J70	9/27
MODEL MX-J50	9/11

TAPE P.B. SIGNAL

MIC & Headphone Section

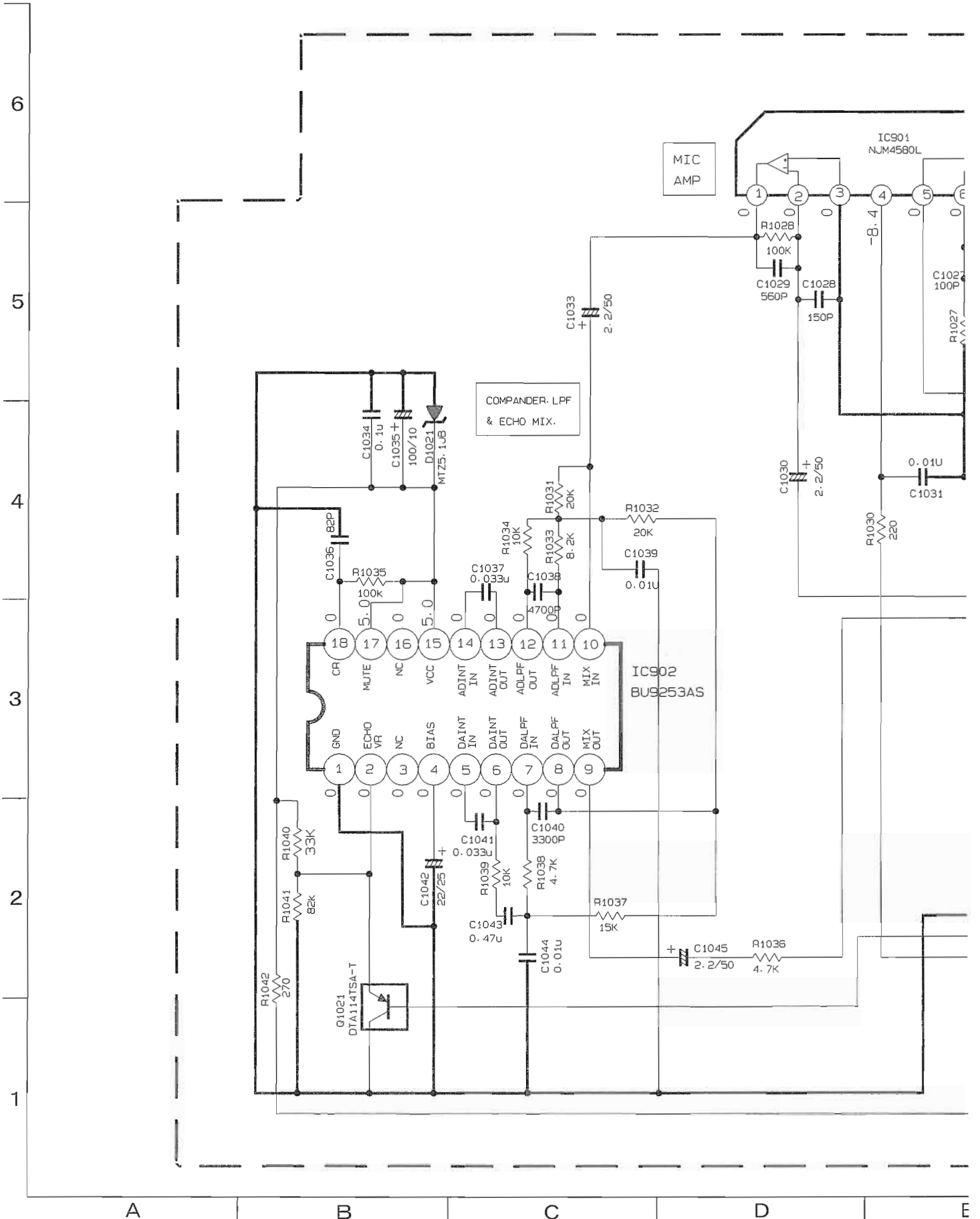

CA-MXJ55R/CA-MXJ530R

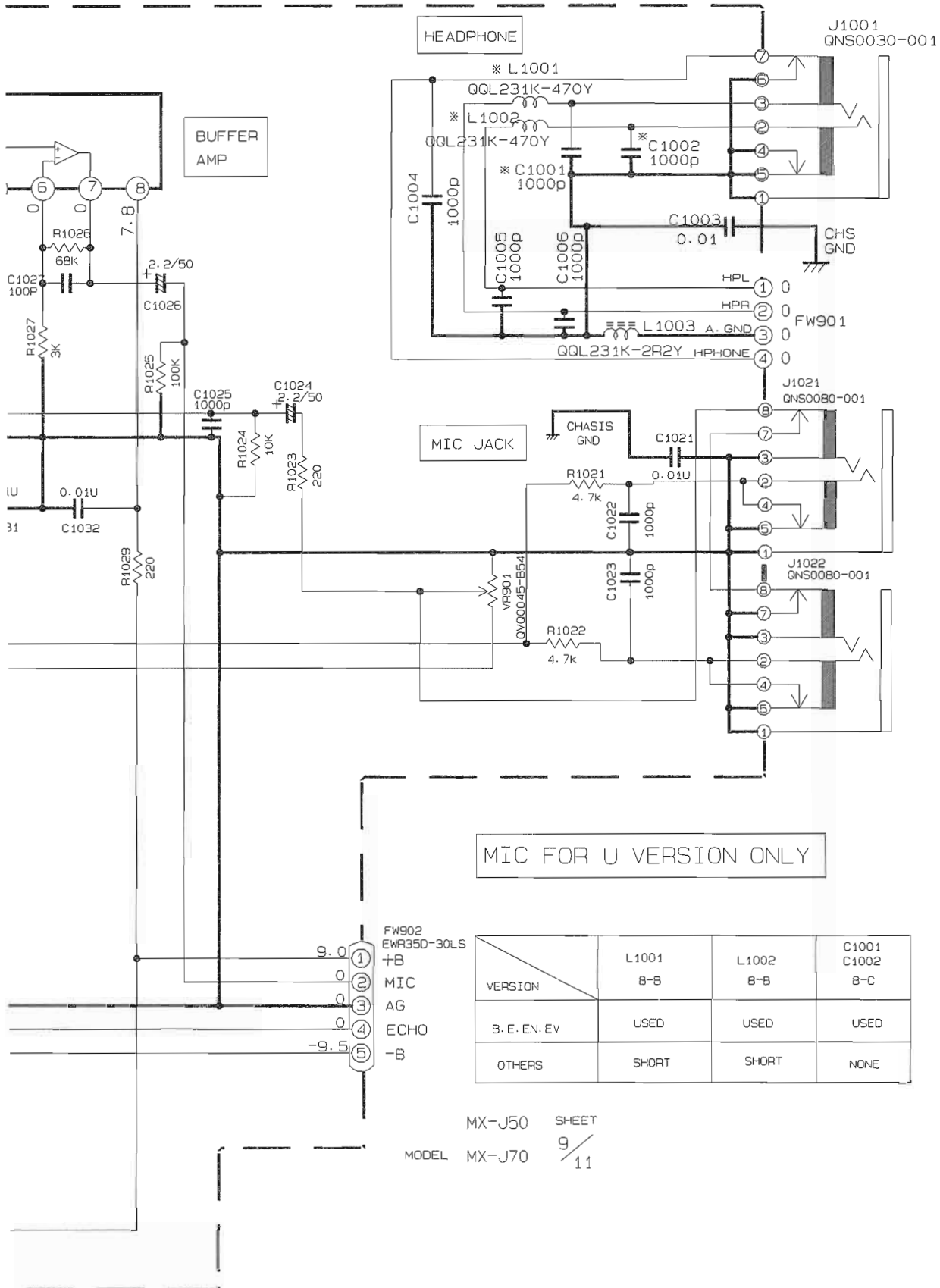

MIC FOR U VERSION ONLY

VERSION	L1001	L1002	C1001 C1002
B. E. EN. EV	USED	USED	USED
OTHERS	SHORT	SHORT	NONE

MX-J50 SHEET 9/11
MODEL MX-J70

CD Servo & CD Mechanism Control Section

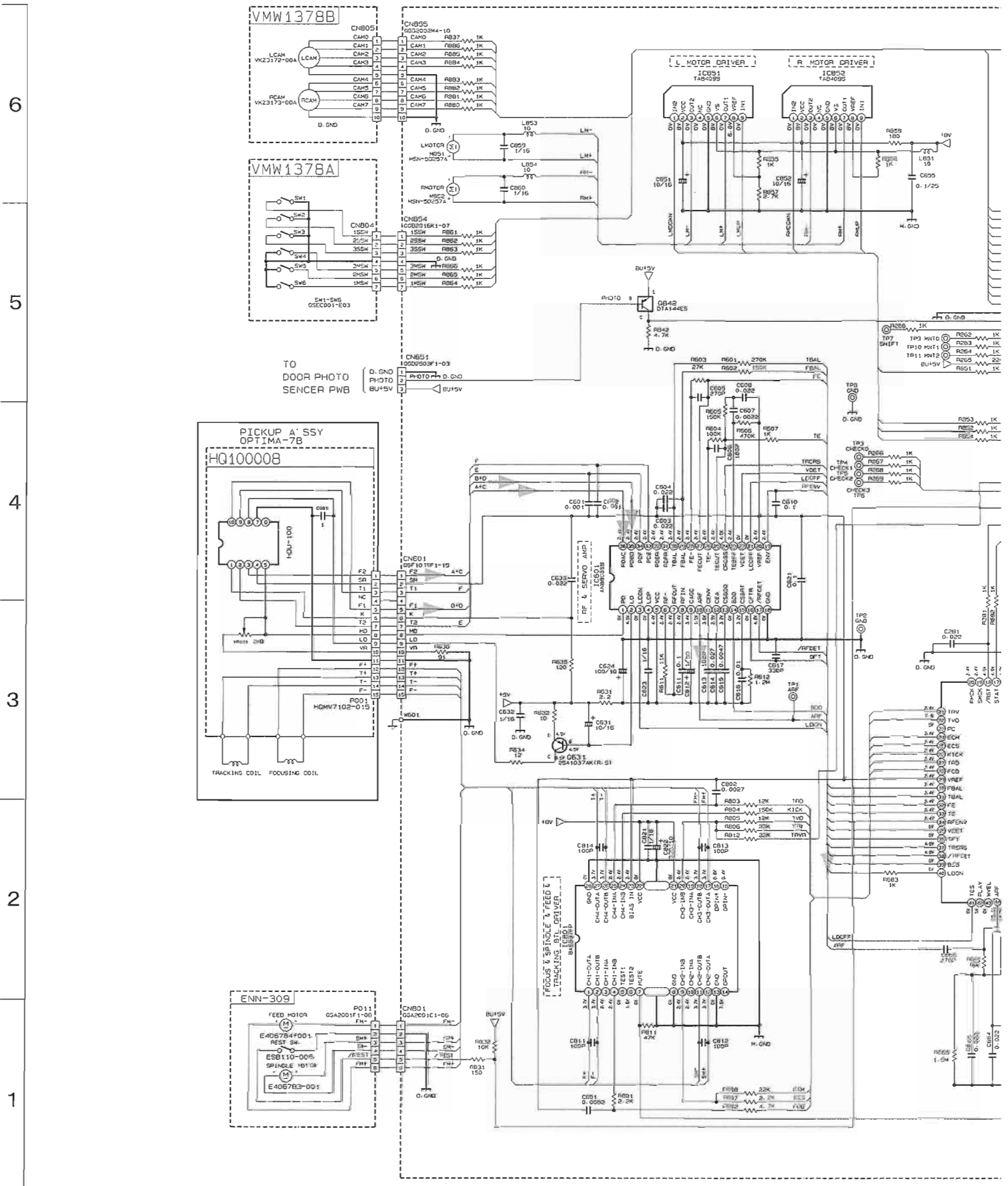

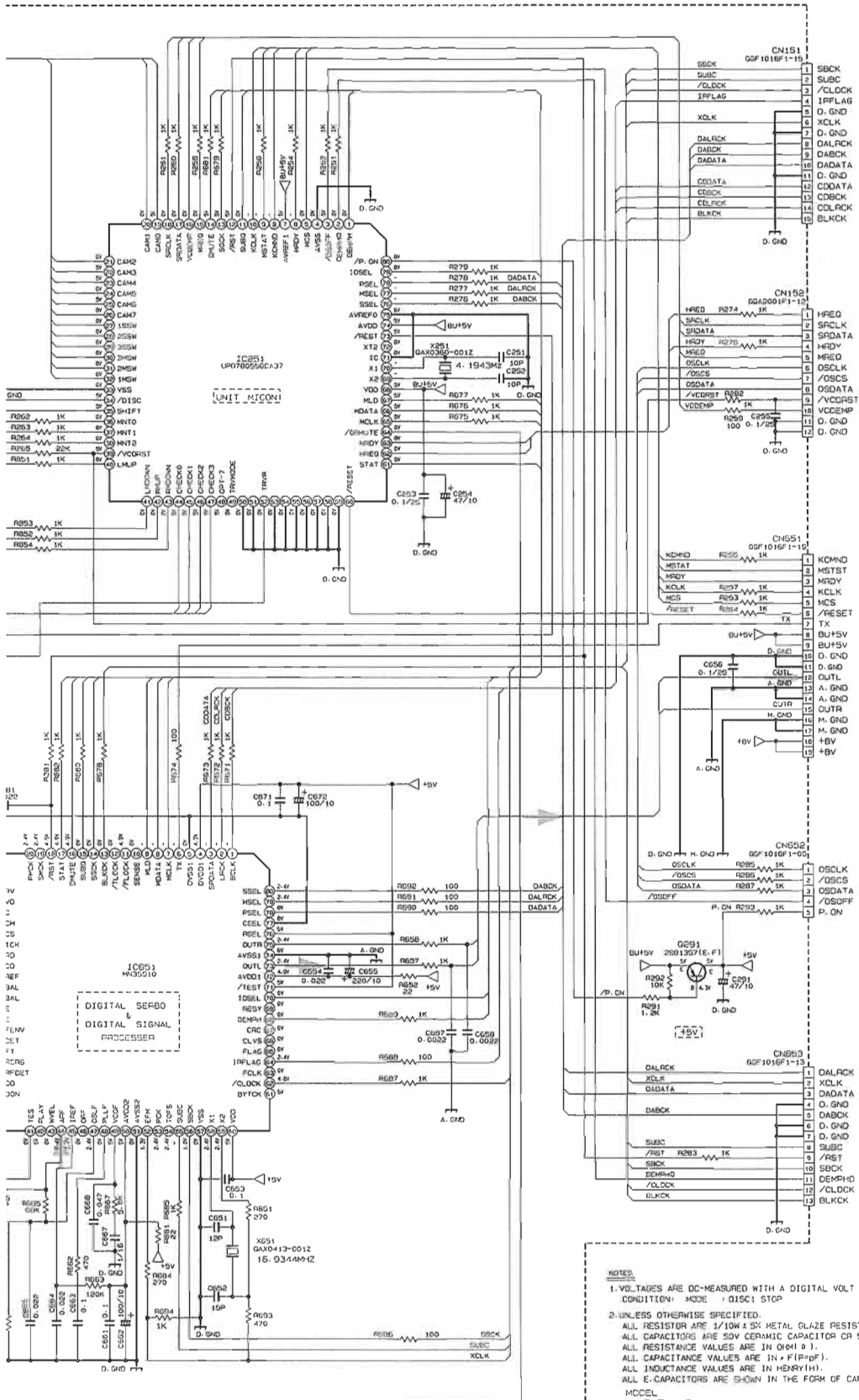

TO ENV-004
VIDEO CD BOARD

TO AMP

NOTES

1. VOLTAGES ARE DC-MEASURED WITH A DIGITAL VOLT METER CONDITION: MODE = DISC STOP
2. UNLESS OTHERWISE SPECIFIED:
ALL RESISTORS ARE 1/10W ± 5% METAL GLAZE RESISTOR.
ALL CAPACITORS ARE 50V CERAMIC CAPACITOR OR 50V MYLAR CAPACITOR.
ALL RESISTANCE VALUES ARE IN OHM (Ω).
ALL CAPACITANCE VALUES ARE IN PICO (pF).
ALL INDUCTANCE VALUES ARE IN MEGAHENRY (M).
ALL E-CAPACITORS ARE SHOWN IN THE FORM OF CAPACITANCE (µF)/RATED VOLTAGE (V).

VC3-21
VDH1040-201CV

→ CD SIGNAL

EMW10729

Head Amplifier & Mechanism Control Section

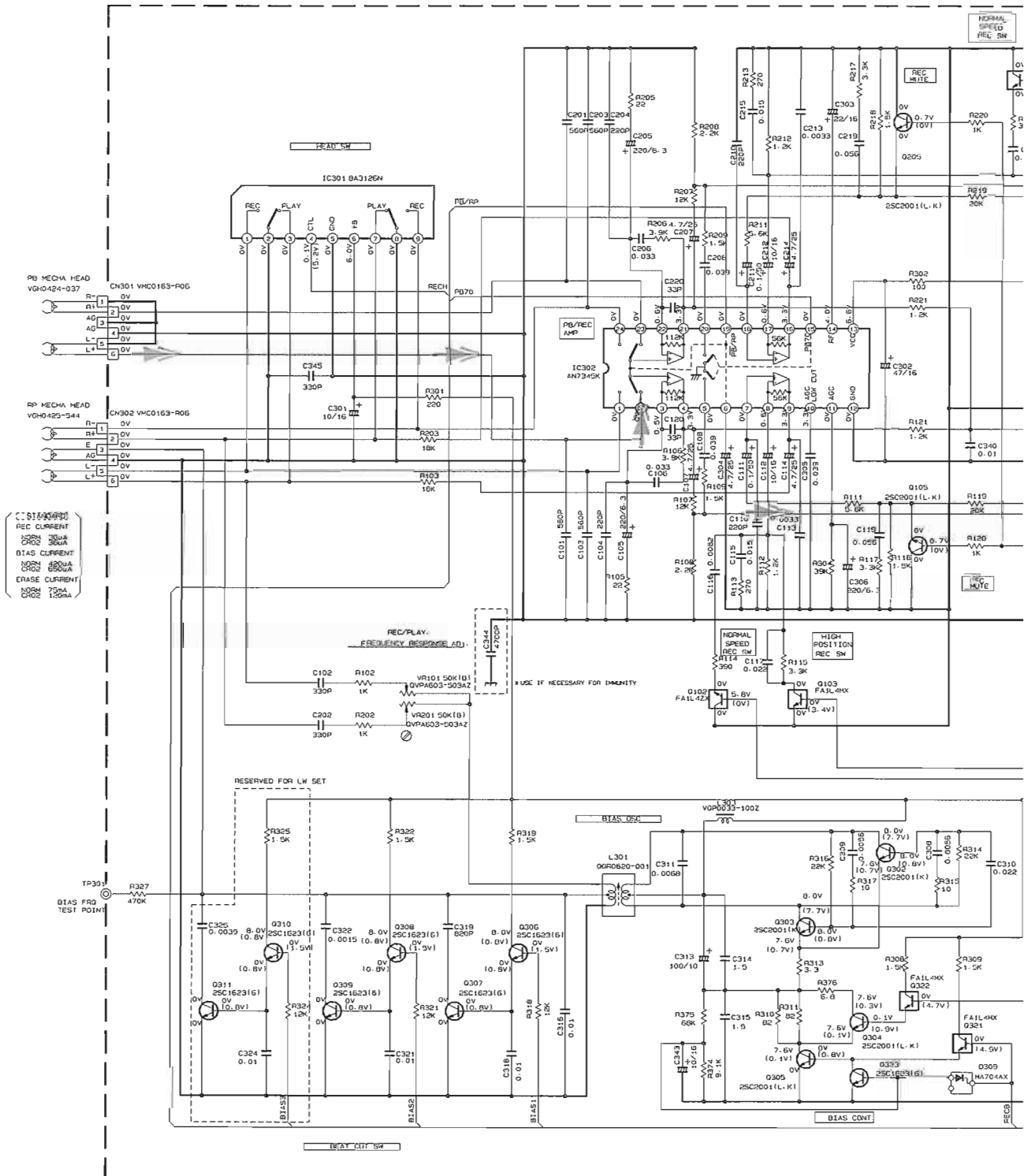

REC CURRENT
500µA
500µA
BIAS CURRENT
100µA
100µA
ERASE CURRENT
750µA
1500µA

- NOTES**
- VOLTAGES ARE DC-MEASURED WITH A DIGITAL VOLT METER OR OSCILLOSCOPE WITHOUT INPUT SIGNAL. () IS INVERT MODE
 - UNLESS OTHERWISE SPECIFIED ALL RESISTANCE VALUES ARE IN OHM (Ω) ALL CAPACITORS ARE CERAMIC CAPACITOR ALL CAPACITANCE VALUES ARE IN PICO-FARAD (pF) ALL INDUCTANCE VALUES ARE IN MILLI-HENRY (mH) ALL E-CAPACITORS ARE SHOWN IN THE FORM OF CAPACITANCE (µF)/RATED VOLTAGE (V).
- ⊕ FLYPPROYLENE CAPACITOR

TABLE 1. DIGITAL TR LIST

PART. NO.	CONSTRUCTION	REF. NO.
FA1F4M		Q317
FA1L4M		D103/Q203 Q321/Q322
FA1L4Z		D102/Q202

A B C D E

CA-MXJ55R/CA-MXJ530R

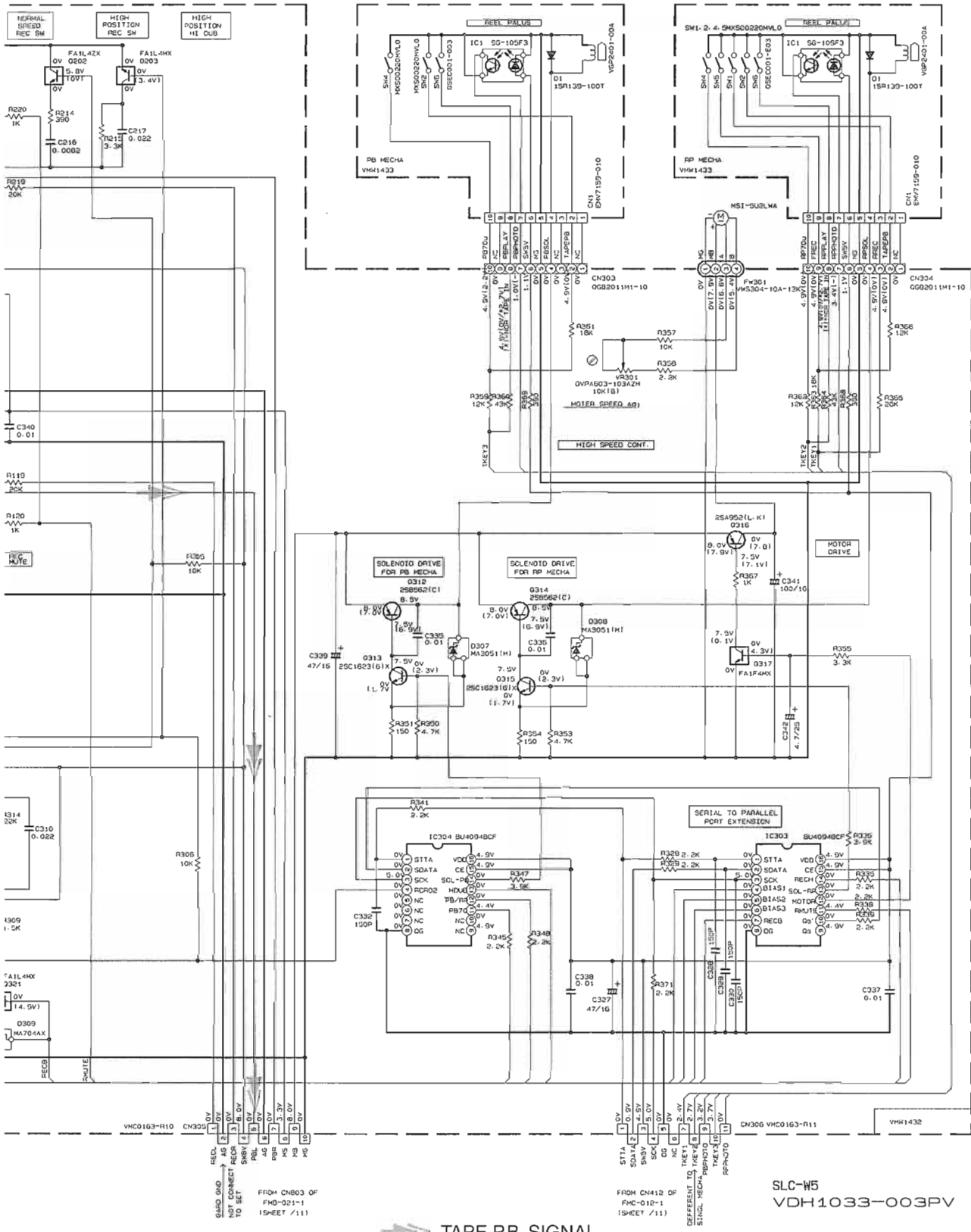

TAPE P.B. SIGNAL

SLC-W5
VDH1033-003PV

Printed Circuit Boards

■ System Control & Operation Switch Board

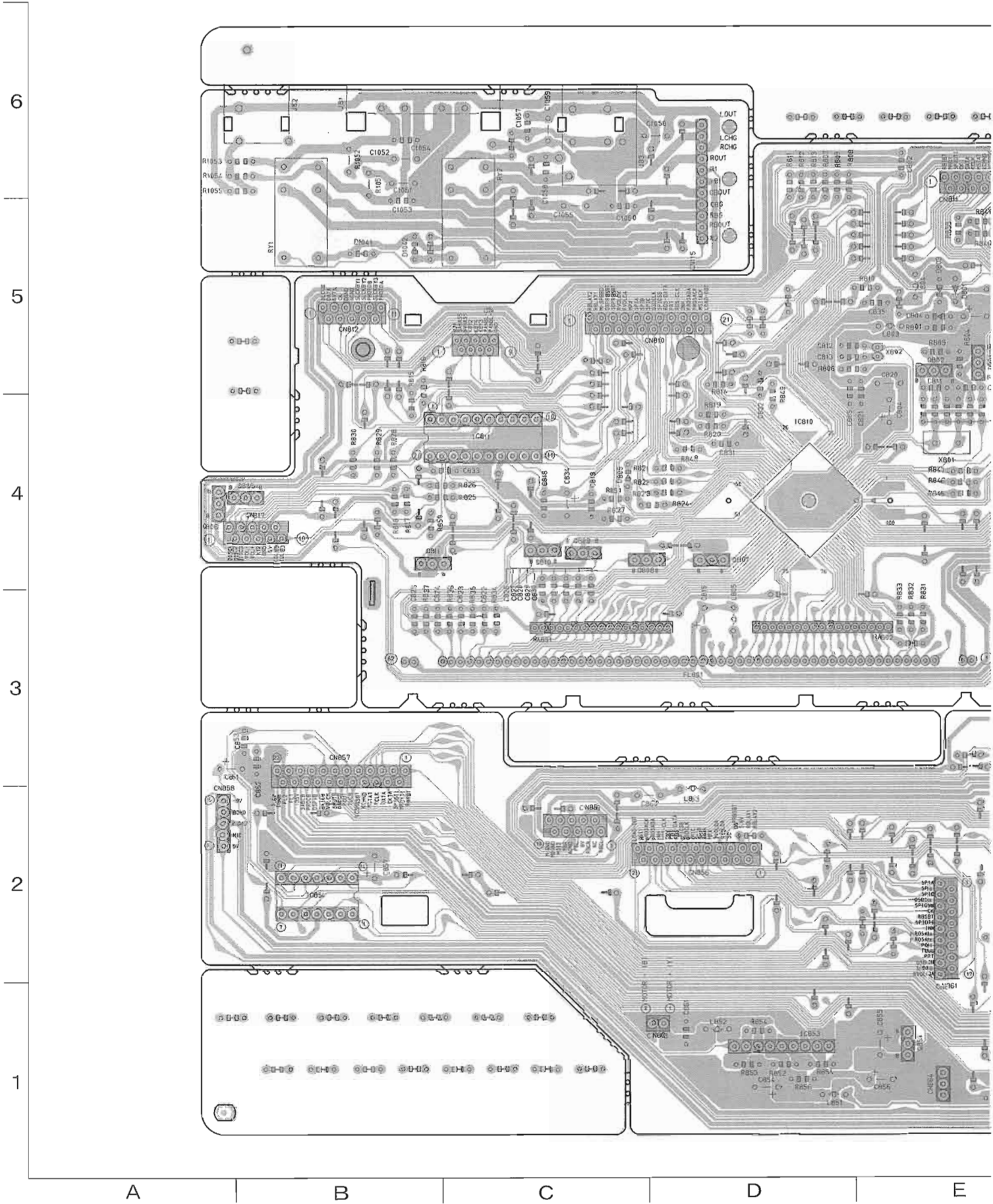

Function, Tuner, Main Board

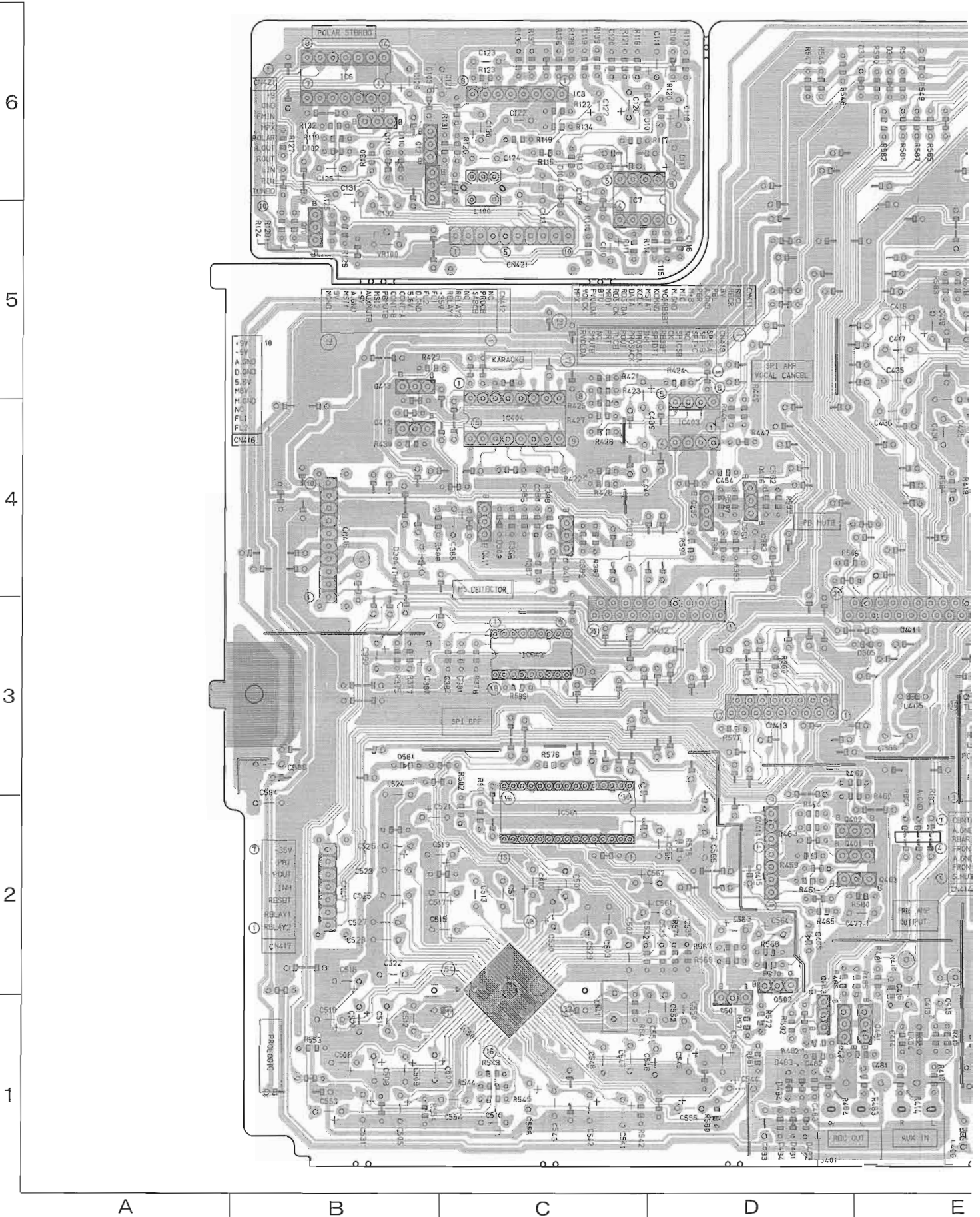

Regulator & Power Amplifier Board

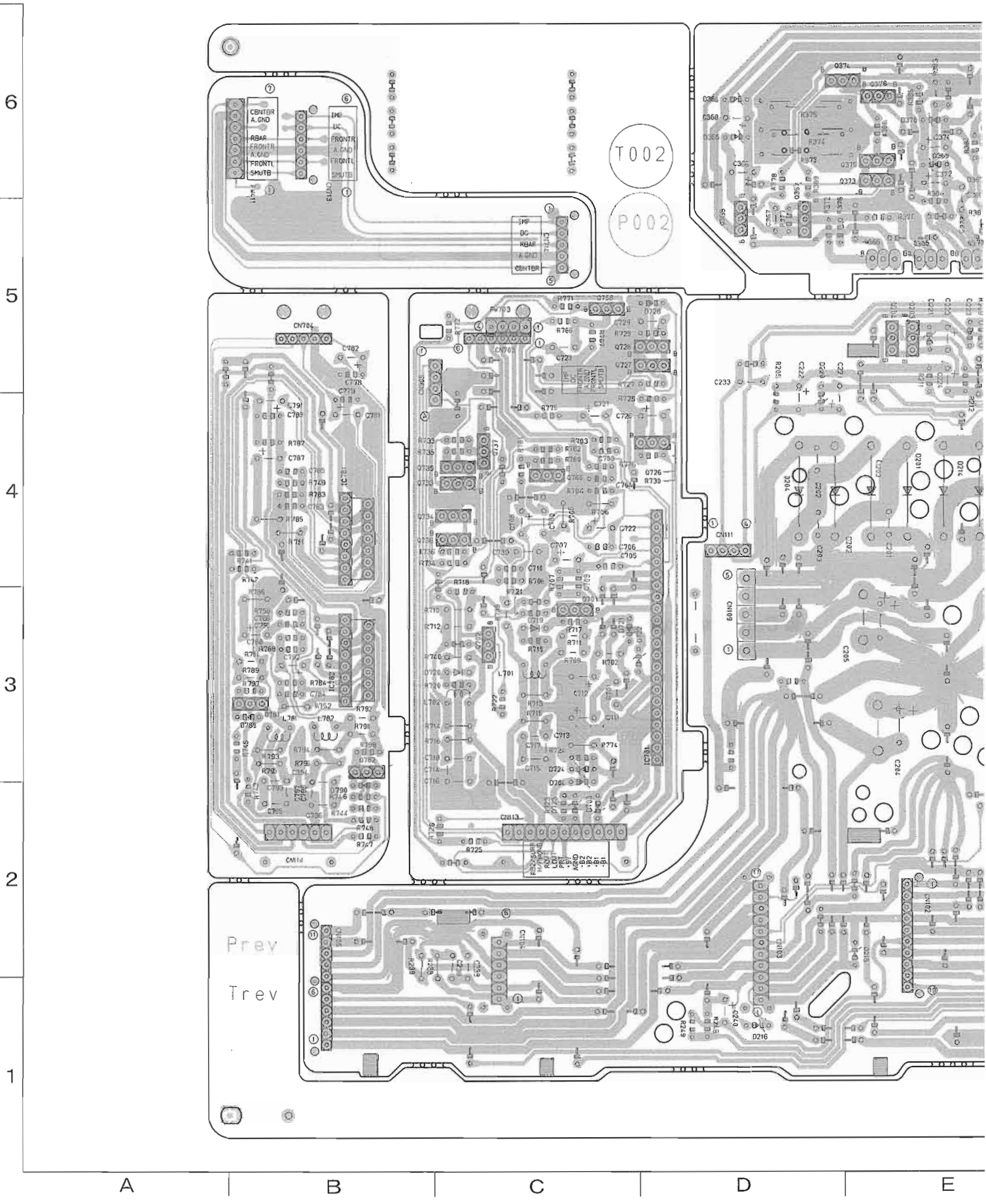

CD Servo Control Board

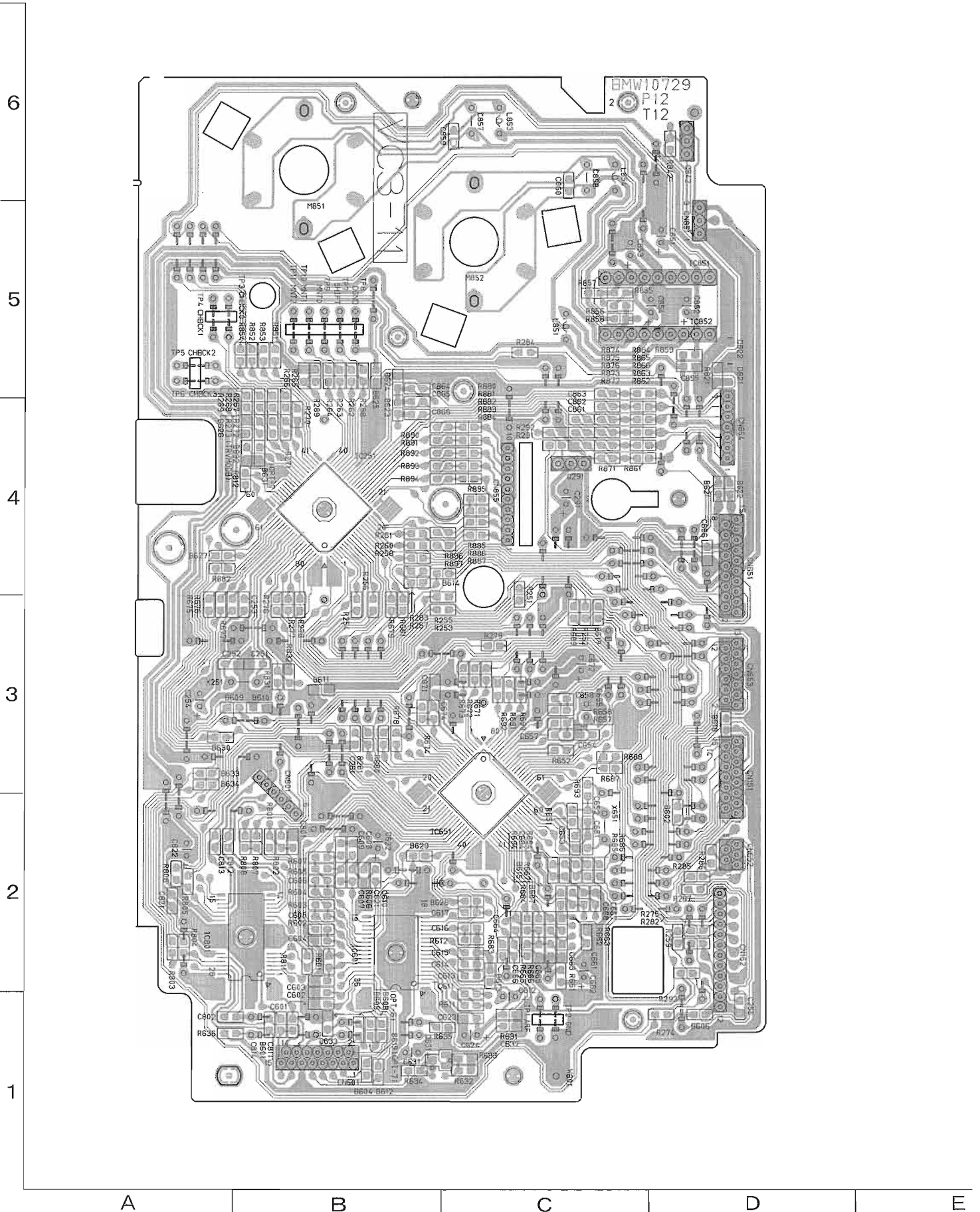

■ CD Tray section switch board

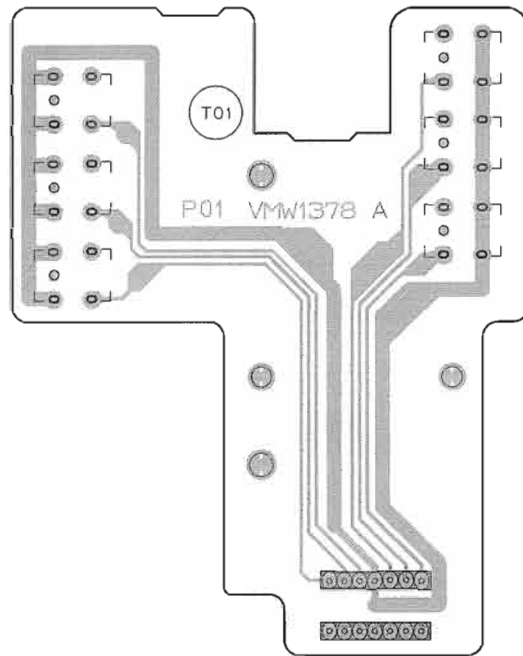

■ Cam switch board

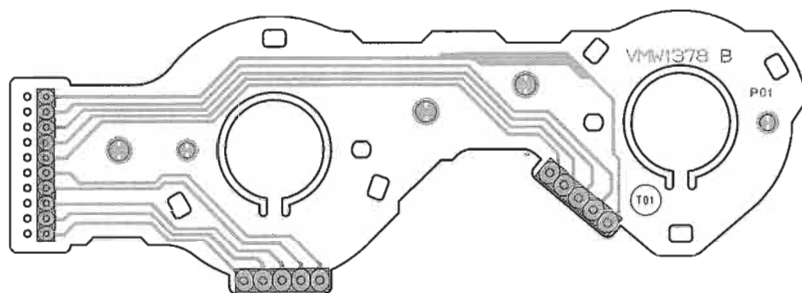

CA-MXJ55R/CA-MXJ530R

<<MEMO>>

PARTS LIST

[MX-J55R]
 [CA-MXJ55R]
 [CA-MXJ530R]

* All printed circuit boards and its assemblies are not available as service parts.

Area Suffix(MX-J55R)

EE ---- Russian Europe

Area Suffix(CA-MXJ55R)

B U.K.
 E -- Continental Europe
 EN ---- Northern Europe
 EV ---- Eastern Europe

Area Suffix(CA-MXJ530R)

B U.K.
 E -- Continental Europe
 EN ---- Northern Europe
 EV ---- Eastern Europe

- Contents -

Exploded View of General Assembly and Parts List	3-3
CD Changer Mechanism Ass'y and Parts List	3-6
CD Mechanism Ass'y and Parts List	3-8
Cassette Mechanism Ass'y and Parts List	3-9
Electrical Parts List	3-11
Packing Materials and Accessories Parts List	3-26

CA-MXJ55R/CA-MXJ530R

<<MEMO>>

Exploded View of General Assembly and Parts List

Block No. M 1 M M

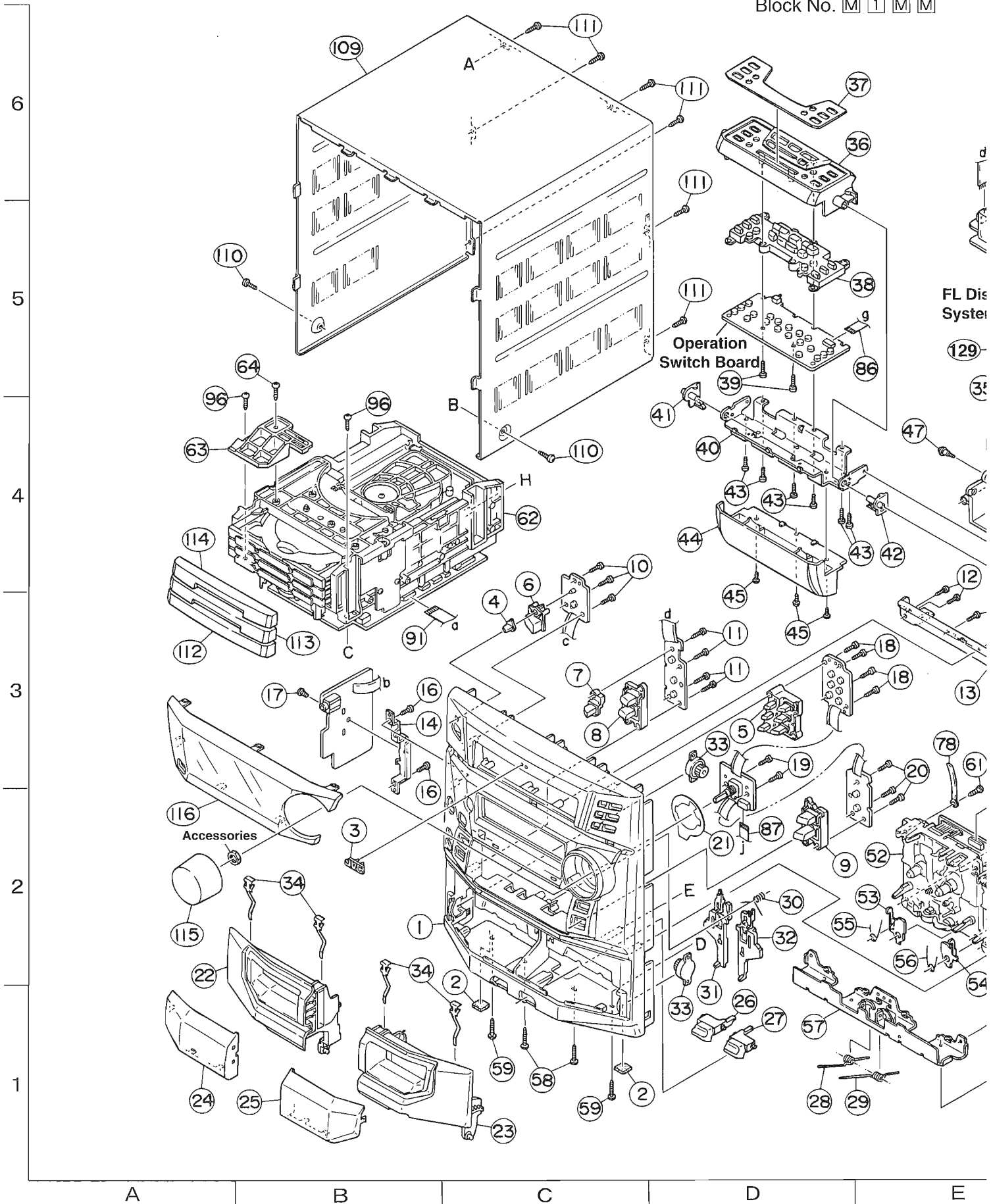

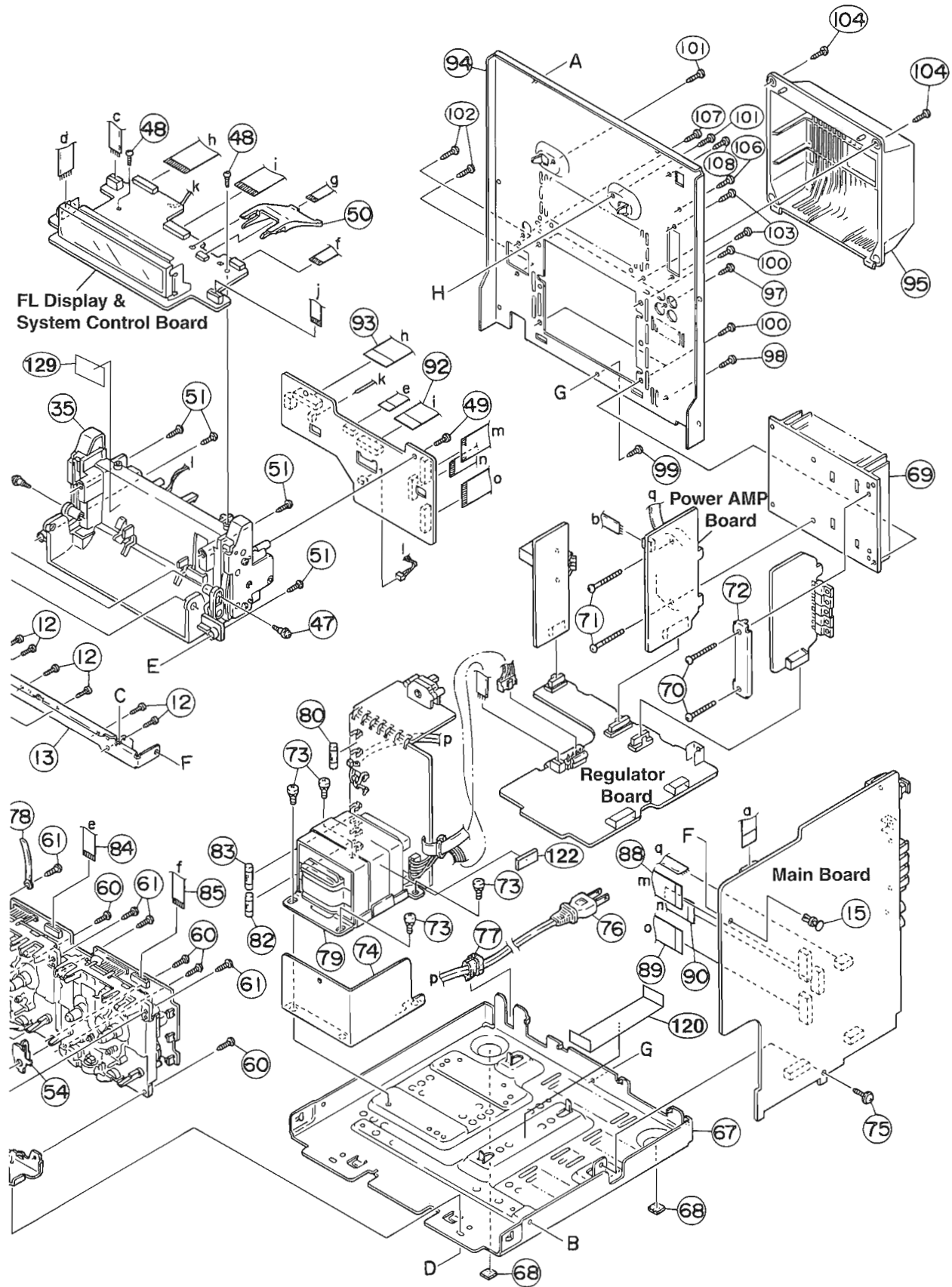

E F G H I

■ Parts List(General Assembly)

Block No.M1MM

△	Item	Parts Number	Parts Name	Q'ty	Description	Area
	1	GV10010-018A	FRONT PANEL	1		
	2	E75896-001	SPACER	2		
	3	VJD5429-001	JVC MARK	1		
	4	GV40016-001A	STBY.INDICATOR	1		
	5	GV30047-008A	CD BUTTON ASSY	1		
	6	GV30029-006A	POWER BUTTON	1		
	7	GV30045-004A	PUSH BUTTON	1		
	8	GV20033-001A	SOURCE BUTTON(A)	1		
	9	GV20034-001A	SOURCE BUTTON(B)	1		
	10	QYSDSF2608Z	SCREW	3		
	11	QYSDSF2608Z	SCREW	4		
	12	QYSDSF2608Z	SCREW	6		
	13	GV30030-001A	STAY BRACKET	1		
	14	GV40030-001A	PHONE BRACKET	1		
	15	FMYH4004-001	PLASTIC RIVET	1		
	16	QYSDSF2608Z	SCREW	2		
	17	QYSBST3006Z	TH TAP SCREW	1		
	18	QYSDSF2608Z	SCREW	4		
	19	QYSDSF2608Z	SCREW	2		
	20	QYSDSF2608Z	SCREW	3		
	21	GV40043-001A	VOLUME SHEET	1		
	22	GV20022-004A	CASSETTE HOLDER(L)	1		
	23	GV20023-004A	CASSETTE HOLDER(R)	1		
	24	GV20024-001A	CASSETTE LENS(L)	1		
	25	GV20025-001A	CASSETTE LENS(R)	1		
	26	GV30026-004A	EJECT BUTTON(A)	1		
	27	GV30027-004A	EJECT BUTTON(B)	1		
	28	FMKW4009-001	HOLDER SPRING(A)	1		
	29	FMKW4010-001	HOLDER SPRING(B)	1		
	30	FMKW4011-001	SPRING	1		
	31	FMKS3002-003	EJECT LEVER(A)	1		
	32	FMKS3003-003	EJECT LEVER(B)	1		
	33	GV40034-001A	DAMPER	2		
	34	VKY4180-401	CASSETTE SPRING	4		
	35	GV10014-003A	CASE ASSY	1		
	36	GV30039-004A	MOVING PANEL(A)	1	CA-MXJ55R/MX-J55R	
		GV30039-006A	MOVING PANEL(A)	1	CA-MXJ530R	
	37	GV30040-017A	CONTROL SHEET	1		
	38	GV30041-007A	CONTROL BTN.ASSY	1		
	39	QYSDSF2608Z	SCREW	2		
	40	GV30042-002A	PANEL BRACKET	1		
	41	GV40028-001A	PANEL HOLDER(L)	1		
	42	GV40028-002A	PANEL HOLDER(R)	1		
	43	QYSDSF2608Z	SCREW	6		
	44	GV30043-004A	MOVING PANEL(B)	1	CA-MXJ55R/MX-J55R	
		GV30043-005A	MOVING PANEL(B)	1	CA-MXJ530R	
	45	QYSBST2606Z	T.SCREW	3		
	47	VKZ4341-204	SPECIAL SCREW	2		
	48	QYSDSF2608Z	SCREW	2		
	49	QYSDSF2608Z	SCREW	1		
	50	GV30054-001A	BOARD HOLDER	1		

■ Parts List(General Assembly)

Block No.M1MM

△	Item	Parts Number	Parts Name	Q'ty	Description	Area
	51	QYSSSF3012Z	SCREW	4		
	52	-----	CASSETTE MECHA	1		
	53	FMKL4012-004	EJECT SAFETY(A)	1		
	54	FMKL4013-001	EJECT SAFETY(B)	1		
	55	FMKW4007-001	EJECT SPRING(A)	1		
	56	FMKW4008-001	EJECT SPRING(B)	1		
	57	GV20030-001A	HOLDER BRACKET	1		
	58	QYSBSG3010E	T.SCREW	2		
	59	QYSBSG3010E	T.SCREW	2		
	60	QYSBSG3010Z	T.SCREW	4		
	61	QYSBSF3010Z	SCREW	4		
	62	-----	CD CHANGER MECHA	1		
	63	E309662-001SM	DISC STOPPER	1		
	64	QYSBSF3008Z	SCREW	1		
	67	GV10011-001A	CHASSIS BASE	1		
	68	E75896-006	FELT SPACER	2		
△	69	GV30044-002A	HEAT SINK	1		
	70	QYSBSG3014E	T.SCREW	2		
	71	QYSBSG3020E	TAPPING SCREW	2		
	72	GV40029-001A	LEAF SPRING	1		
	73	QYSDSTL4008Z	SPECIAL SCREW	4		
	74	LE30469-001A	SHIELD PLATE	1		
	75	QYSBSGG3008E	T.SCREW	1		
△	76	QMPK090-205-JN	POWER CORD	1		E,EE,EN,EV
△		QMPN090-200-JC	POWER CORD	1		B
	77	QZW0033-001	STRAIN RELIEF	1		
	78	VKZ4001-110S	WIRE HOLDER	1		
△	79	QQT0251-002	POWER TRANSFORMER	1	T001	
△	80	QMF51E2-1R25-J1	FUSE	1	F001	
△	82	QMF51E2-3R15-J1	FUSE	1	F101	
△	83	QMF51E2-3R15-J1	FUSE	1	F102	
	84	QUQ412-1014CJ	FLAT WIRE	1	FC854	
	85	QUQ412-1115DJ	FLAT WIRE	1	FC803	
	86	QUQ610-0915BJ	FLAT WIRE	1	FC921	
	87	QUQ412-1012CJ	FLAT WIRE	1	FC971	
	88	QUQ412-2109CJ	FLAT WIRE	1	FC857	
	89	QUQ412-2109CJ	FLAT WIRE	1	FC855	
	90	QUQ412-1712CJ	FLAT WIRE	1	FC856	
	91	QUQ110-1916BJ	FLAT WIRE	1	FC410	
	92	QUQ412-2112CJ	FLAT WIRE	1	FC801	
	93	QUQ412-2308CJ	FLAT WIRE	1	FC802	
	94	GV10013-019A	REAR PANEL	1	CA-MXJ55R	
		GV10013-021A	REAR PANEL	1	MX-J55R	
		GV10013-022A	REAR PANEL	1	CA-MXJ530R	
	95	E207356-002SM	REAR COVER	1		
	96	QYSBSG3008Z	T.SCREW	2		
	97	QYSBSGY3008E	SPECIAL SCREW	1		
	98	QYSBSGY3008E	SPECIAL SCREW	1		
	99	QYSBSGY3008E	SPECIAL SCREW	1		
	100	QYSBSGY3008E	SPECIAL SCREW	4		
	101	QYSBSGY3008E	SPECIAL SCREW	2		

■ Parts List(General Assembly)

Block No.M1MM

△	Item	Parts Number	Parts Name	Q'ty	Description	Area
	102	QYSBSGY3008E	SPECIAL SCREW	2		
	103	QYSBSGY3008E	SPECIAL SCREW	2		
	104	QYSBSGY3008E	SPECIAL SCREW	2		
	106	QYSBSGY3008E	SPECIAL SCREW	1		
	107	QYSBSGY3008E	SPECIAL SCREW	1		
	108	QYSBSGY3008E	SPECIAL SCREW	1		
	109	GV10012-001A/S/	METAL COVER	1		
	110	QYSDSG3006M	TAPPING SCREW	2		
	111	QYSBSGY3008E	SPECIAL SCREW	6		
	112	GV30033-003A	CD FITTING	1	CA-MXJ55R/MX-J55R	
		GV30033-004A	CD FITTING	1	CA-MXJ530R	
	113	GV30034-002A	CD FITTING	1	CA-MXJ55R/MX-J55R	
		GV30034-003A	CD FITTING	1	CA-MXJ530R	
	114	GV30035-003A	CD FITTING	1	CA-MXJ55R/MX-J55R	
		GV30035-004A	CD FITTING	1	CA-MXJ530R	
	115	GV30028-004A	VOLUME KNOB	1		
	116	GV20026-005A	WINDOW SCREEN	1	CA-MXJ55R/MX-J55R	
		GV20026-003A	WINDOW SCREEN	1	CA-MXJ530R	
	120	GV40048-001A	PROTECT SHEET	1		
	122	FMYSH103-003	FELT SPACER	1		
	129	GV40059-001A	SPACER	1		

CD Changer Mechanism Ass'y and Parts List

Block No. M 2 M M

VC3-21M

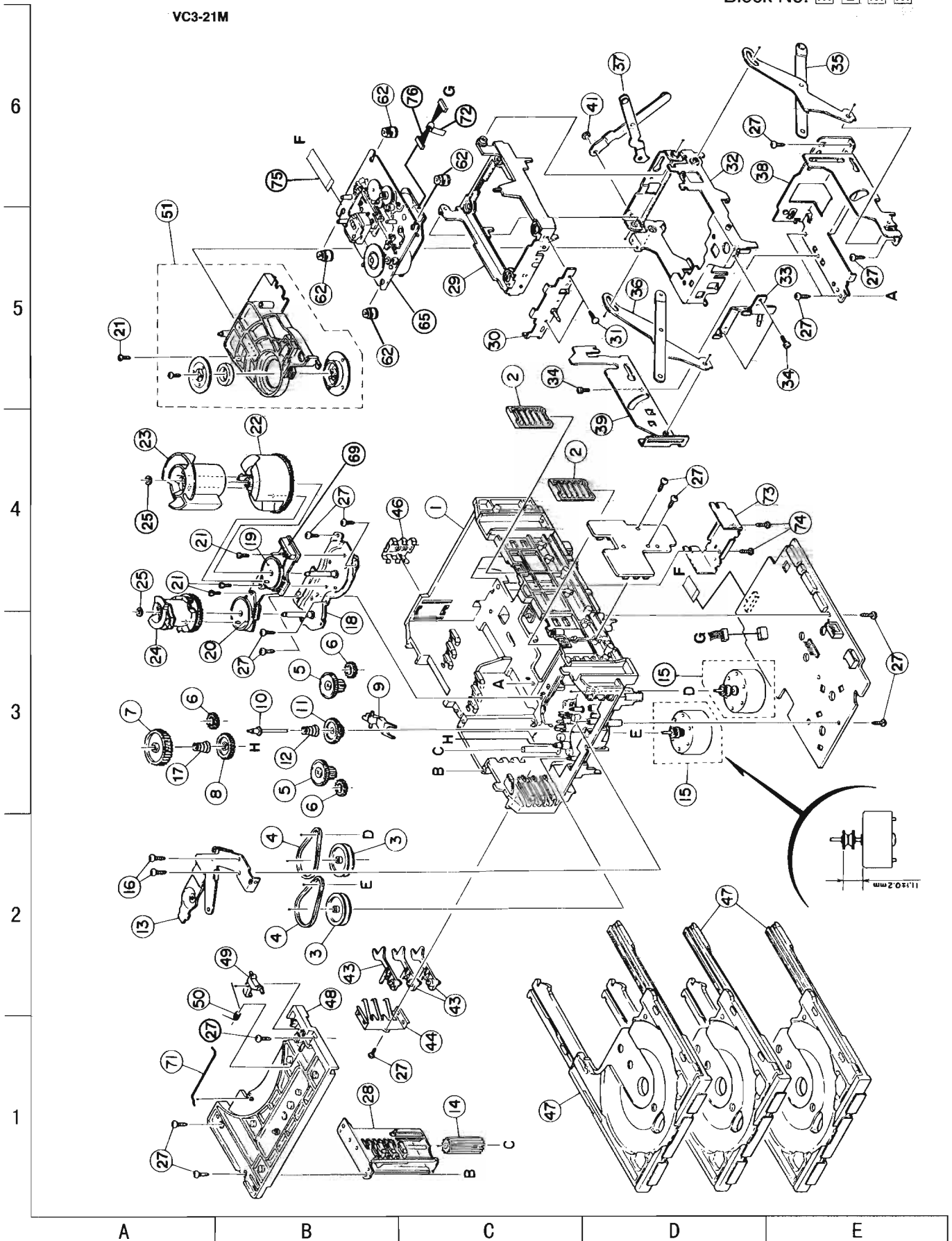

■ Parts List (CD Changer Mechanism)

BLOCK NO. **M2MM**

REF.	PARTS NO.	PARTS NAME	REMARKS	QTY	SUFFIX	CLR
1	VKS1144-003	CHASSIS		1		
2	VKS3698-003	TRAY GUIDE		2		
3	VKS5532-003	PULLEY GEAR		2		
4	VKB3000-164	BELT		2		
5	VKS5505-003	GEAR B		2		
6	VKS5506-002	GEAR C		3		
7	VKS5507-002	CROSS GEAR U		1		
8	VKS5508-002	CROSS GEAR L		1		
9	VKS5510-003	SELECT LEVER		1		
10	VKH5769-001	S.G.SHAFT		1		
11	VKS5511-002	SELECT GEAR		1		
12	VKW5155-003	COMP.SPRING	FOR SELECT GEAR	1		
13	VKM3846-002	GEAR BRACKET		1		
14	VKS5509-002MM	CYLINDER GEAR		1		
15	MSN5D257A-SA2	D.C.MOTOR ASS'Y		2		
16	QYSPSPD2616Z	SCREW	FOR MOTOR	2		
17	LV40612-001A	COMP.SPRING		1		
18	VKM3825-00AMM	C.G.BASE ASS'Y		1		
19	VKZ3172-00ASS	CAM SW. R ASS'Y		1		
20	VKZ3173-00ASS	CAM SW. L ASS'Y		1		
21	QYSPST2606Z	SCREW		4		
22	VKS2263-002MM	CAM R1		1		
23	VKS2264-002MM	CAM R2		1		
24	VKS2265-002MM	CAM GEAR L		1		
25	WDL316050MM	SLIT WASHER		2		
27	QYSBSF2608Z	T.SCREW		16		
28	VKS3702-00FMM	DRIVE UNIT		1		
29	VKS2247-004	MECHA HOLDER A		1		
30	VKL7767-00B	BRACKET ASS'Y		1		
31	QYSBSF2606Z	SCREW	FOR BRACKET	2		
32	VKM3860-00A	M.HOLDER B AS'Y		1		
33	VKL7802-00C	M.HOLDER C AS'Y		1		
34	QYSDST2604Z	SCREW		3		
35	VKL7810-00A	LIFTER ASS'Y R		1		
36	VKL7811-00A	LIFTER ASS'Y L		1		
37	VKL7812-00A	LIFTER ASS'Y H		1		
38	VKL2732-002	LIFTER BASE		1		
39	VKM3857-001	LIFTER BRACKET		1		
41	WDL266035-2	SLIT WASHER		1		
43	VKS5514-002MM	LOCK LEVER		3		
44	VKY3133-002MM	RETURN SPRING		1		
46	VKY3134-003MM	CLICK SPRING		1		
47	VKS2252-00E	TRAY ASS'Y		3		
48	VKS2250-003	TOP BRACKET		1		
49	VKS5515-002	S.TRAY STOPPER		1		
50	VKW5156-004	TORSION SPRING		1		
51	VKS3703-00F	CLAMPER ASS'Y		1		
62	LV40761-003A	INSULATOR		4		
65	-----	CD MECHA		1		
69	QGB2012J1-10	CONNECTOR		1		
71	VKW5187-001	ROD		1		
72	VYSA1R2-033	SPACER		1		
73	LE30611-001A	C.B HOLDER	FOR CD CB	1		
74	QYSBSF3008Z	SCREW	FOR HOLDER	2		
75	QUQ610-1509AJ	FLAT WIRE	TRAVERSE 15	1		
76	EWS176-008	FLAT WIRE	TRAVERSE 6	1		

CD Mechanism Ass'y and Parts List

■ Grease Point

Block No. **M 3 M M**

No. EXL-M7TB

G-31KB
(Grease to apply have to be alittle for the exchange)

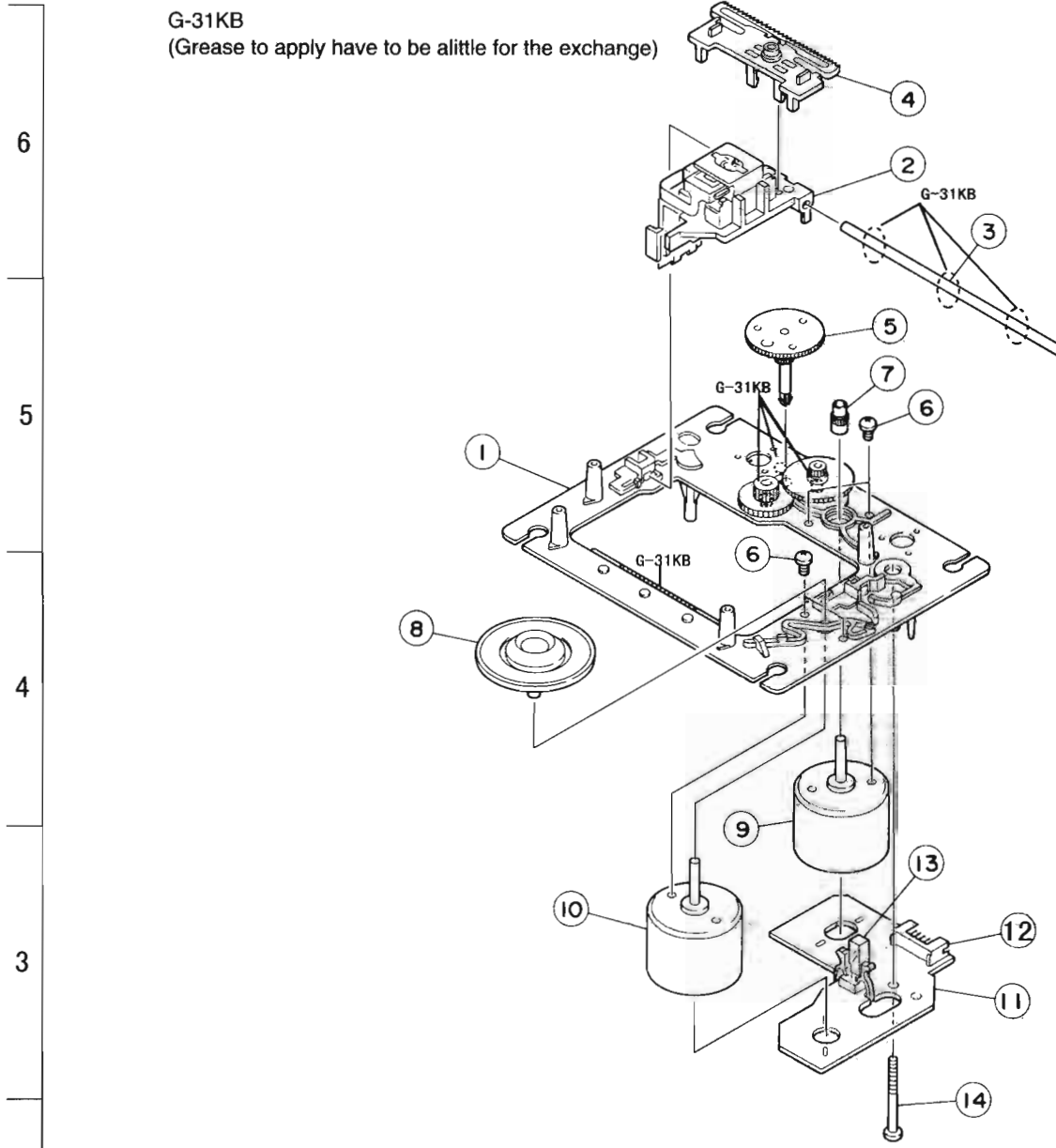

■ CD Mechanism Assembly Parts List

Item	Parts Number	Parts Name	Q'ty	Description	Area
1	E102731-221SMKP	MECHA. BASE ASSY	1		
2	OPTIMA-7B	OPTICAL PICK UP	1		
3	E406777-002SMKP	CD SHAFT	1		
4	HQN300031-001PK	CD RACK	1		
5	E307745-441SMKP	MECHA GEAR	1		
6	QYSDSP2003N	SCREW	4		
7	E406750-441SM	PINION GEAR	1		
8	EPB309173PKA	TURN TABLE	1		
9	E406784-001	FEED MOTOR	1		
10	E406783-001	SPPINDLE MOTOR	1		
11	EMW10190-441	P. C. BOARD	1		
12	QGA2001F1-06	6P PLUG ASSY	1		
13	QSW0506-001	LEAF SWITCH	1		
14	E75832-221SS	SCREW	1		

A B C D E

Cassette Mechanism Ass'y and Parts List

Block No. M 4 M M

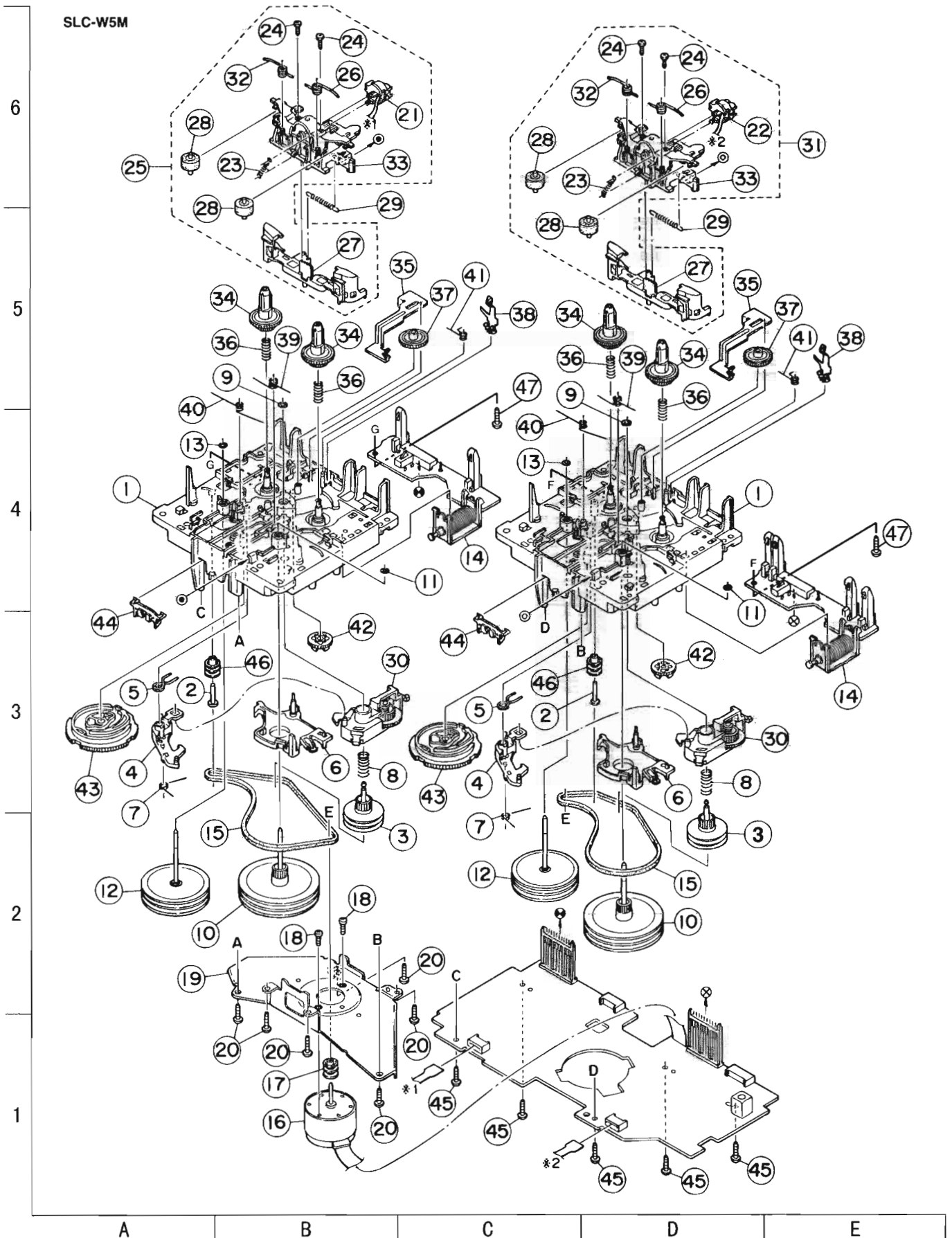

■ Parts List (Cassette Mechanism)

BLOCK NO. **MM**

REF.	PARTS NO.	PARTS NAME	REMARKS	QTY	SUFFIX	CLR
1	VKS1165-00H	CHASSIS B.ASS'Y		2		
2	VKH5786-002	SHAFT		2		
3	VKS5603-00D	MAIN PULLEY ASY		2		
4	VKS3785-001MM	FR ARM		2		
5	VKW5284-002	SWING SPRING		2		
6	VKS2278-003	TRIGGER ARM		2		
7	VKW5301-001	FR SPRING		2		
8	VKW5266-001	ELEVATOR SPRING		2		
9	WDL214025	WASHER		2		
10	VKF3205-00B	F.WHEEL ASSY(R)		2		
11	WDL183425	SLIT WASHER		2		
12	VKF3207-00B	F.WHEEL ASSY(L)		2		
13	WDL173525-6	SLIT WASHER		2		
14	VKZ3174-00A	DC SOLENOID		2		
15	VKB3000-182	CAPSTAN BELT(B)		2		
16	MSI-5U2LWA	D.C.MOTOR ASS'Y		1		
17	VKR4761-001	MOTOR PULLEY		1		
18	QYSPSP2604Z	SCREW		2		
19	VKM3907-001	JOINT BRACKET		1		
20	QYSBSF2608Z	T.SCREW		6		
21	VGH0424-037	P.B.HEAD		1		
22	VGH0425-544	R/P&E HEAD		1		
23	VKW5302-001	HEAD SPRING		2		
24	VKZ4730-001	SPECIAL SCREW		4		
25	VKS2279-00C	HEAD MOUNT ASSY		1		
26	VKW5299-002	PIN ROL.SP.(R)		2		
27	VKS2277-005	DIRECTION LEVER		2		
28	VKP4233-00A	PINCH ROL. ASSY		4		
29	VKW5285-001	RETURN SPRING		2		
30	VKS3786-00G	CLUTCH ASS'Y		2		
31	VKS2275-00C	HEAD MOUNT ASSY		1		
32	VKW5300-002	PIN ROL.SP.(L)		2		
33	VKS1167-001	HEAD MOUNT BASE		2		
34	VKS2274-002	REEL GEAR		4		
35	VKM3906-003	PLAY SW LEVER		2		
36	VKW5286-002	B.T. SPRING		4		
37	VKS5559-001	PLAY IDLE GEAR		2		
38	VKY3149-002	CASSETTE SP.		2		
39	VKW5279-001	HEAD BASE SP(R)		2		
40	VKW5280-001	HEAD BASE SP(L)		2		
41	VKW5296-001	EARTH SPRING		2		
42	VKS5597-00A	FR GEAR ASS'Y		2		
43	VKS1166-003	CONTROL CAM		2		
44	VKS5577-001	FPC HOLDER		2		
45	QYSBSF2608Z	T.SCREW	FOR P.W.B.	5		
46	VKR4749-001	IDLE PULLEY		2		
47	QYSBSF2006Z	SCREW		2		

■ Electrical Parts List(Power AMP Board)

Block No.01

△	Item	Parts Number	Description	Area
		I.C.S		
△	IC701	STK411-210E	I.C(HYBRID)	
		DIODES		
△	D201	1N5402M-20	DIODE	
△	D202	1N5402M-20	DIODE	
△	D203	1N5402M-20	DIODE	
△	D204	1N5402M-20	DIODE	
△	D211	30DF2-FC	DIODE	
△	D212	30DF2-FC	DIODE	
△	D213	30DF2-FC	DIODE	
△	D214	30DF2-FC	DIODE	
△	D217	1SR35-100A-T5	SI DIODE	
△	D218	1SR35-100A-T5	SI DIODE	
	D219	MTZJ33C-T2	Z DIODE I M	
	D220	MTZJ9.1C-T2	ZENER DIODE	
	D221	MTZJ5.1B-T2	ZENER DIODE	
	D223	1SS133-T2	SI.DIODE	
	D224	1SS133-T2	SI.DIODE	
	D225	1SS133-T2	SI.DIODE	
△	D227	1SR35-100A-T5	SI DIODE	
	D244	MTZJ2.4B-T2	Z.DIODE I.M	
	D245	1SS133-T2	SI.DIODE	
	D360	MTZJ5.1B-T2	ZENER DIODE	
	D361	MTZJ11C-T2	ZENER DIODE	
	D362	MTZJ6.8C-T2	ZENER DIODE	
	D365	MTZJ9.1B-T2	ZENER DIODE	
	D366	MTZJ11C-T2	ZENER DIODE	
	D367	MTZJ10C-T2	ZENER DIODE	
	D368	MTZJ11C-T2	ZENER DIODE	
	D369	MTZJ10C-T2	ZENER DIODE	
	D370	MTZJ11C-T2	ZENER DIODE	
	D703	MTZJ8.2C-T2	ZENER DIODE	
	D704	MTZJ8.2C-T2	ZENER DIODE	
	D719	1SS133-T2	SI.DIODE	
	D720	1SS133-T2	SI.DIODE	
	D721	MTZJ8.2C-T2	ZENER DIODE	
	D722	MTZJ8.2C-T2	ZENER DIODE	
	D723	MTZJ33C-T2	Z DIODE I M	
	D724	MTZJ33C-T2	Z DIODE I M	
	D728	1SS133-T2	SI.DIODE	
		TRANSISTORS		
△	Q201	2SB1274/RS/	TRANSISTOR	
	Q203	KRC107M-T	DIGITAL TRANSISTOR	
	Q204	KRC107M-T	DIGITAL TRANSISTOR	
	Q205	KRC107M-T	DIGITAL TRANSISTOR	
	Q240	KTC3199/GL/-T	TR I/M	
△	Q360	2SD2061/EF/	SI.TRANSISTOR	
	Q361	KTC3199/GL/-T	TR I/M	
	Q362	KTC3199/GL/-T	TR I/M	
△	Q365	2SD2061/EF/	SI.TRANSISTOR	
△	Q366	2SD2061/EF/	SI.TRANSISTOR	
	Q367	KTA1267/YG/-T	TRANSISTOR	
	Q368	KTC3199/GL/-T	TR I/M	
△	Q369	2SD2061/EF/	SI.TRANSISTOR	
	Q370	KTC3199/GL/-T	TR I/M	
△	Q371	2SB1565/EF/	SI.TRANSISTOR	
	Q373	KRA104M-T	DIGITAL TRANSISTOR	
	Q374	KRC104M-T	DIGITAL TRANSISTOR	
	Q375	KRC104M-T	DIGITAL TRANSISTOR	
	Q376	KRA104M-T	DIGITAL TRANSISTOR	
	Q701	2SA1038S/SE/-T	SI.TRANSISTOR	
	Q702	2SA1038S/SE/-T	SI.TRANSISTOR	
	Q726	2SC2389S/SE/-T	SI.TRANSISTOR	
	Q727	2SA1038S/SE/-T	SI.TRANSISTOR	
	Q728	KTC3199/GL/-T	TR I/M	
	Q733	2SC3576-JVC-T	SI.TRANSISTOR	
	Q734	2SC3576-JVC-T	SI.TRANSISTOR	

△	Item	Parts Number	Description	Area
	Q735	2SC3576-JVC-T	SI.TRANSISTOR	
	Q736	2SC3576-JVC-T	SI.TRANSISTOR	
	Q737	KRA111M-T	DIGITAL TRANSISTOR	
	Q758	2SA1038S/S/-T	TR.I.M	
	Q760	2SK301/PQ/-T	F.E.T.	
		CAPACITORS		
	C201	QFV82AJ-104	0.1MF 100V THIN FILM CA	
	C202	QFV82AJ-104	0.1MF 100V THIN FILM CA	
	C203	QFV82AJ-104	0.1MF 100V THIN FILM CA	
△	C204	QEZO461-478	4700MF E CAP.	
△	C205	QEZO461-478	4700MF E CAP.	
	C211	QFVJ1HJ-104Z	0.1MF 50V TF CAP.	
	C212	QFVJ1HJ-104Z	0.1MF 50V TF CAP.	
	C213	QFVJ1HJ-104Z	0.1MF 50V TF CAP.	
△	C214	QETM1VM-228J7	2200MF 35V E.CAP.	
△	C215	QETM1VM-228J7	2200MF 35V E.CAP.	
	C216	QETN1VM-107Z	100MF 35V E.CAP.	
	C217	QETN1JM-476Z	47MF 63V E.CAP.	
	C218	EETC1HM-226ZJC	22MF 50V E.CAPA. I.M	
	C219	QDYB1CM-103Y	0.01MF 16V CER.CAP.	
	C220	EETC1HM-226ZJC	22MF 50V E.CAPA. I.M	
	C221	EETB1HM-475E	4.7MF 50V E.CAP.	
	C222	EETB1HM-475E	4.7MF 50V E.CAP.	
	C223	QETC1HM-225ZM	2.2MF 50V E.CAP.	
	C224	EETB1HM-105E	1MF 50V E.CAP.	
	C233	QFLM1HJ-103Z	0.01MF 50V M CAP.	
	C240	QETC1HM-224Z	0.22MF 50V AL E.CAP.	
	C360	EETC1EM-226ZE	22MF 25V E.CAP.	
	C361	QCF31HZ-103Z	0.01MF 50V C CAP.	
	C362	EETC1EM-226ZE	22MF 25V E.CAP.	
	C366	EETC1EM-226ZE	22MF 25V E.CAP.	
	C367	QCF31HZ-103Z	0.01MF 50V C CAP.	
	C368	EETC1EM-226ZE	22MF 25V E.CAP.	
	C369	EETC1EM-226ZE	22MF 25V E.CAP.	
	C370	QCF31HZ-103Z	0.01MF 50V C CAP.	
	C371	EETC1EM-226ZE	22MF 25V E.CAP.	
	C372	EETC1EM-226ZE	22MF 25V E.CAP.	
	C373	QCF31HZ-103Z	0.01MF 50V C CAP.	
	C374	EETC1EM-226ZE	22MF 25V E.CAP.	
	C703	QCBB1HK-471Y	470PF 50V CER.CAP.	
	C704	QCBB1HK-471Y	470PF 50V CER.CAP.	
	C705	QCSB1HJ-220	22PF 50V CER.CAP.	
	C706	QCSB1HJ-220	22PF 50V CER.CAP.	
	C707	QETC1EM-476ZM	47MF 25V E.CAP.	
	C708	QETC1EM-476ZM	47MF 25V E.CAP.	
	C709	QCSB1HJ-100Y	10PF 50V CER.CAP.	
	C710	QCSB1HJ-100Y	10PF 50V CER.CAP.	
	C711	QETN1JM-476Z	47MF 63V E.CAP.	
	C712	QETN1JM-476Z	47MF 63V E.CAP.	
	C713	QFVJ1HJ-104Z	0.1MF 50V TF CAP.	
	C714	QFVJ1HJ-104Z	0.1MF 50V TF CAP.	
	C715	QFVJ1HJ-104Z	0.1MF 50V TF CAP.	
	C716	QFVJ1HJ-104Z	0.1MF 50V TF CAP.	
	C721	QTE1V06-106Z	AL E.CAP.	
	C722	QTE1V06-106Z	AL E.CAP.	
	C723	QFVJ1HJ-474Z	0.47MF 50V CAP.	
	C726	EETB1EM-106E	10MF 25V E.CAP.	
	C729	EETB1CM-476	47MF 16V E.CAP.	
	C739	QFLM1HJ-103Z	0.01MF 50V M CAP.	
	C780	QFLM1HJ-823Z	0.082MF 50V MYLAR CAP.	
	C799	QDYB1CM-103Y	0.01MF 16V CER.CAP.	EE
		QFLM1HJ-103Z	0.01MF 50V M CAP.	B,E,EN,EV
		RESISTORS		
	R203	QRE141J-332Y	3.3K 1/4W C RES.	
	R204	QRE141J-223Y	22K 1/4W C RES.	
	R205	QRE141J-104Y	100K 1/4W C RES.	
	R209	QRE141J-103Y	10K 1/4W CARBON RES.	

CA-MXJ55R/CA-MXJ530R

■ Electrical Parts List(Power AMP Board)

Block No.01

△	Item	Parts Number	Description	Area
	R210	QRE141J-472Y	4.7K 1/4W C RES.	
	R211	QRE141J-182Y	1.8K 1/4W C RES.	
	R215	QRE141J-473Y	47K 1/4W C RES.	
	R216	QRE141J-473Y	47K 1/4W C RES.	
	R242	QRE141J-222Y	2.2K 1/4W C RES.	
	R245	QRE141J-222Y	2.2K 1/4W C RES.	
	R247	QRE141J-222Y	2.2K 1/4W C RES.	
	R248	QRE141J-473Y	47K 1/4W C RES.	
	R249	QRE141J-153Y	15K 1/4W C RES.	
	R290	QRE141J-102Y	1K 1/4W C RES.	
	R291	QRE141J-102Y	1K 1/4W C RES.	
	R292	QRE141J-102Y	1K 1/4W C RES.	
	R293	QRE141J-102Y	1K 1/4W C RES.	
	R294	QRE141J-103Y	10K 1/4W CARBON RES.	
	R295	QRE141J-183Y	18K 1/4W CARBON RES.	
	R299	QRL012J-332	3.3K 1W UNF.OMF.RES.	
△	R360	QRZ9042-2R2X	2.2 F.RES. I.M	
△	R361	QRZ9042-2R2X	2.2 F.RES. I.M	
	R362	QRE141J-331Y	330 1/4W C RES.	
	R363	QRE141J-331Y	330 1/4W C RES.	
	R364	QRE141J-122Y	1.2K 1/4W C RES.	
	R365	QRE141J-561Y	560 1/4W C RES.	
	R366	QRE141J-561Y	560 1/4W C RES.	
	R367	QRE141J-122Y	1.2K 1/4W C RES.	
	R368	QRE141J-331Y	330 1/4W C RES.	
	R371	QRE141J-4R7Y	4.7 1/4W C RES.	
	R372	QRE141J-4R7Y	4.7 1/4W C RES.	
△	R373	QRZ9021-220	22 FUSIBLE RES.	
△	R374	QRZ9021-220	22 FUSIBLE RES.	
△	R375	QRZ9021-220	22 FUSIBLE RES.	
	R376	QRE141J-221Y	220 1/4W C RES.	
	R377	QRE141J-681Y	680 1/4W CARBON RES.	
	R378	QRE141J-182Y	1.8K 1/4W C RES.	
	R381	QRE141J-272Y	2.7K 1/4W C RES.	
	R382	QRE141J-562Y	5.6K 1/4W C RES.	
	R384	QRE141J-272Y	2.7K 1/4W C RES.	
	R385	QRE141J-562Y	5.6K 1/4W C RES.	
△	R388	QRE141J-103Y	10K 1/4W CARBON RES.	
	R389	QRE141J-103Y	10K 1/4W CARBON RES.	
	R701	QRL01DJ-101X	100 1W OMF RES.	
	R702	QRL01DJ-101X	100 1W OMF RES.	
	R703	QRE141J-563Y	56K 1/4W C RES.	
	R704	QRE141J-563Y	56K 1/4W C RES.	
	R705	QRJ146J-681X	680 1/4W UNF C RES I/	
	R706	QRJ146J-681X	680 1/4W UNF C RES I/	
	R707	QRE141J-563Y	56K 1/4W C RES.	
	R708	QRE141J-563Y	56K 1/4W C RES.	
	R709	QRT01DJ-R22X	0.22 1W UNF.MF.RES.I	
	R710	QRT01DJ-R22X	0.22 1W UNF.MF.RES.I	
	R711	QRT01DJ-R22X	0.22 1W UNF.MF.RES.I	
	R712	QRT01DJ-R22X	0.22 1W UNF.MF.RES.I	
	R713	QRJ146J-100X	10 1/4W UNF.CARBON R	
	R714	QRJ146J-100X	10 1/4W UNF.CARBON R	
	R715	QRJ146J-100X	10 1/4W UNF.CARBON R	
	R716	QRJ146J-100X	10 1/4W UNF.CARBON R	
	R717	QRE141J-122Y	1.2K 1/4W C RES.	
	R718	QRE141J-122Y	1.2K 1/4W C RES.	
	R719	QRE141J-223Y	22K 1/4W C RES.	
	R720	QRE141J-223Y	22K 1/4W C RES.	
	R721	QRE141J-103Y	10K 1/4W CARBON RES.	
	R722	QRE141J-103Y	10K 1/4W CARBON RES.	
	R723	QRE141J-392Y	3.9K 1/4W C RES.	
	R724	QRE141J-392Y	3.9K 1/4W C RES.	
	R725	QRE141J-823Y	82K 1/4W C RES.	
	R726	QRE141J-104Y	100K 1/4W C RES.	
	R727	QRE141J-104Y	100K 1/4W C RES.	
	R728	QRE141J-103Y	10K 1/4W CARBON RES.	

△	Item	Parts Number	Description	Area
	R729	QRE141J-104Y	100K 1/4W C RES.	
	R730	QRE141J-103Y	10K 1/4W CARBON RES.	
	R733	QRE141J-472Y	4.7K 1/4W C RES.	
	R734	QRE141J-472Y	4.7K 1/4W C RES.	
	R735	QRE141J-472Y	4.7K 1/4W C RES.	
	R736	QRE141J-472Y	4.7K 1/4W C RES.	
	R739	QRL01DJ-821X	820 1W OMF RES.	
	R740	QRL01DJ-821X	820 1W OMF RES.	
	R766	QRE141J-333Y	33K 1/4W C RES.	
	R767	QRE141J-683Y	68K 1/4W C RES.	
	R771	QRE141J-222Y	2.2K 1/4W C RES.	
	R772	QRE141J-103Y	10K 1/4W CARBON RES.	
	R774	QRJ146J-100X	10 1/4W UNF.CARBON R	
	R775	QRE141J-102Y	1K 1/4W C RES.	
	R776	QRE141J-102Y	1K 1/4W C RES.	
	R780	QRE141J-105Y	1M 1/4W C RES.	
	R781	QRE141J-392Y	3.9K 1/4W C RES.	
	R782	QRE141J-475Y	4.7M 1/4W C RES.	
		OTHERS		
	L201	QQR0779-001Z	INDUCTOR	B,E,EN,EV
	L701	QQLZ005-R45	INDUCTOR	
	L702	QQLZ005-R45	INDUCTOR	
	CN102	QGB2510J1-10	CONNECT TERMINAL	
	CN103	QGB2501J1-11	CONNECT TERMINAL	
	CN105	QGB2510J1-06	CONNECTOR	
	CN106	QGB2501K2-10	CONNECT TERMINAL	
	CN107	QGB2501K2-07	CONNECT TERMINAL	
	CN109	QGA3901C1-05	5P CONNECTOR	
	CN111	QGD2501C1-04Z	SOCKET ASSY	
	CN112	QGB2510K2-10	CONNECTOR	
	CN113	QGB2501K2-11	CONNECT TERMINAL	
	CN119	EWS285-202V	CONNECTOR WIRE ASSY	
	CN915	QGD2501C1-04Z	SOCKET ASSY	
	EP201	E409182-001SM	EARTH TERMINAL	
	FT111	QNG0020-001Z	FUSE CLIP	
	FT112	QNG0020-001Z	FUSE CLIP	
	FT511	QNG0020-001Z	FUSE CLIP	
	FT512	QNG0020-001Z	FUSE CLIP	
	FT521	QNG0020-001Z	FUSE CLIP	
	FT522	QNG0020-001Z	FUSE CLIP	
	FW101	QUM134-12DGZ4	FLAT WIRE	
	FW703	QUM134-14DGZ4	FLAT WIRE	
	TB101	QNZ0079-001Z	TAB I.M	
	TB102	QNZ0079-001Z	TAB I.M	
	TH202	QAD0095-4R7Z	POSITIVE THERMISTOR	

■ Electrical Parts List(Function,Tuner,Main Board)

△	Item	Parts Number	Description	Area
		I.C.S		
	IC 1	LA1838	I.C(M)	
	IC 2	LC72136N	I.C(M)	
	IC 4	BU1923	I.C(M)	
	IC 6	BU4066BC	I.C(DIGI-MOS)	EE
	IC 7	BA15218	I.C(MONO-ANALOG)	EE
	IC 8	BA15218N	I.C(MONO-ANALOG)	EE
	IC401	TDA7439	I.C(M)	
	IC402	BA15218	I.C(MONO-ANALOG)	
	IC405	BA15218	I.C(MONO-ANALOG)	
	IC406	LA2650	I.C(MONO-ANALOG)	
	IC542	BA3835S	I.C(M)	
		DIODES		
	D 1	1SS133-T2	SI.DIODE	
	D 2	1SS133-T2	SI.DIODE	
	D 3	1SS133-T2	SI.DIODE	
	D 4	1SS133-T2	SI.DIODE	
	D 5	MTZJ5.6B-T2	ZENER DIODE	
	D 6	MTZJ5.6B-T2	ZENER DIODE	
	D 8	1SS133-T2	SI.DIODE	
	D100	RB721Q-T2	SI.DIODE	EE
	D101	RB721Q-T2	SI.DIODE	EE
	D102	1SS133-T2	SI.DIODE	EE
	D103	1SS133-T2	SI.DIODE	EE
	D104	1SS133-T2	SI.DIODE	EE
	D110	1SS133-T2	SI.DIODE	EE
	D111	1SS133-T2	SI.DIODE	EE
	D303	1SS133-T2	SI.DIODE	
	D305	1SS133-T2	SI.DIODE	
	D306	1SS133-T2	SI.DIODE	
	D307	1SS133-T2	SI.DIODE	
	D481	1SS133-T2	SI.DIODE	
	D482	1SS133-T2	SI.DIODE	
	D483	1SS133-T2	SI.DIODE	
	D484	1SS133-T2	SI.DIODE	
	D485	1SS133-T2	SI.DIODE	
	D501	MTZJ5.1B-T2	ZENER DIODE	
		TRANSISTORS		
	Q 1	2SC1923/O-T	TR TAPE	
	Q 2	KRA107M-T	DIGITAL TRANSISTOR	
	Q 3	KTC3199/GL-T	TR I/M	
	Q 4	KTC3199/GL-T	TR I/M	
	Q 6	KRA107M-T	DIGITAL TRANSISTOR	
	Q 14	2SA1175/HFE-T	TRANSISTOR	
	Q100	KTC3199/GL-T	TR I/M	EE
	Q101	KRC102M-T	DIGITAL TRANSISTOR	EE
	Q102	KTC3199/GL-T	TR I/M	EE
	Q103	KRC102M-T	DIGITAL TRANSISTOR	EE
	Q401	2SC3576-JVC-T	SI.TRANSISTOR	
	Q402	2SC3576-JVC-T	SI.TRANSISTOR	
	Q403	KRA102M-T	DIGITAL TRANSISTOR	
	Q405	2SC3576-JVC-T	SI.TRANSISTOR	
	Q406	2SC3576-JVC-T	SI.TRANSISTOR	
	Q407	2SA1175/HFE-T	TRANSISTOR	
	Q408	KTC3199/GL-T	TR I/M	
	Q409	KRC114M-T	SI.TRANSISTOR	
	Q410	KTC3199/GL-T	TR I/M	
	Q411	KTC3199/GL-T	TR I/M	
	Q481	2SC3576-JVC-T	SI.TRANSISTOR	
	Q482	2SC3576-JVC-T	SI.TRANSISTOR	
	Q483	KRA102M-T	DIGITAL TRANSISTOR	
		CAPACITORS		
	C 1	QCBB1HK-223Y	0.022MF 50V CER.CAP.	
	C 3	QCBB1HK-473Y	0.047MF 50V CER.CAP.	
	C 4	QDYB1CM-103Y	0.01MF 16V CER.CAP.	
	C 5	EETC1CM-106ZJC	10MF 16V AL E.CAP.	EE
		QETN1AM-107Z	100MF 10V AL E.CAP.	B,E,EN,EV

△	Item	Parts Number	Description	Area
	C 8	QCSB1HJ-150Y	15PF 50V CER.CAP.	
	C 9	QDXB1CM-272Y	2700PF 16V C.CAPA. I.M	
	C 10	EETC1HM-474ZJC	0.47MF 50V E.CAP.	
	C 12	QCSB1HJ-150Y	15PF 50V CER.CAP.	
	C 13	QFLM1HJ-473Z	0.047MF 50V M CAP.	B,E,EN,EV
	C 14	QCBB1HK-473Y	0.047MF 50V CER.CAP.	
	C 18	QCBB1HK-471Y	470PF 50V CER.CAP.	EE
		QDXB1CM-152Y	1500PF 16V C CAP.	B,E,EN,EV
	C 19	QCBB1HK-471Y	470PF 50V CER.CAP.	EE
		QDXB1CM-152Y	1500PF 16V C CAP.	B,E,EN,EV
	C 20	EETC1HM-226ZJC	22MF 50V E.CAPA. I.M	
	C 21	QCBB1HK-473Y	0.047MF 50V CER.CAP.	
	C 22	QFVJ1HJ-274Z	0.27MF 50V CAP.	
	C 23	EETC1HM-105ZJC	1MF 50V E.CAP.	
	C 24	EETC1HM-226ZJC	22MF 50V E.CAPA. I.M	
	C 25	QFLM1HJ-223Z	0.022MF 50V M CAP.	
	C 26	EETB1EM-106E	10MF 25V E.CAP.	
	C 27	EETB1HM-105E	1MF 50V E.CAP.	
	C 28	EETB1HM-105E	1MF 50V E.CAP.	
	C 29	QFLM1HJ-182Z	1800PF 50V MYLAR CAP.	
	C 30	QFLM1HJ-182Z	1800PF 50V MYLAR CAP.	
	C 31	QCSB1HJ-330Y	33PF 50V CER.CAP.	B,E,EN,EV
	C 32	QCGB1HK-102	1000PF 50V CER.CAP.	
	C 33	QCBB1HK-473Y	0.047MF 50V CER.CAP.	
	C 34	QETB1HM-474N	0.47MF 50V E.CAP.	
	C 35	QDYB1CM-103Y	0.01MF 16V CER.CAP.	
	C 36	EETB1HM-105E	1MF 50V E.CAP.	
	C 37	QETB1HM-474N	0.47MF 50V E.CAP.	
	C 38	EETB1HM-105E	1MF 50V E.CAP.	
	C 39	QCBB1HK-223Y	0.022MF 50V CER.CAP.	
	C 40	QETC1EM-107Z	100MF 25V AL E.CAP.	
	C 41	QCBB1HK-473Y	0.047MF 50V CER.CAP.	
	C 42	QCBB1HK-473Y	0.047MF 50V CER.CAP.	
	C 43	QCBB1HK-473Y	0.047MF 50V CER.CAP.	
	C 51	QENC1HM-105Z	1MF 50V NP E.CAP.	EE
	C 52	QENC1HM-105Z	1MF 50V NP E.CAP.	EE
	C 60	QKCC1AM-107Z	100MF 10V E CAP.	
	C 61	QCSB1HJ-120Y	12PF 50V CER.CAP.	
	C 62	QCSB1HJ-120Y	12PF 50V CER.CAP.	
	C 63	QCBB1HK-473Y	0.047MF 50V CER.CAP.	
	C 65	QCGB1HK-102	1000PF 50V CER.CAP.	
	C 66	QCBB1HK-151	150PF 50V CER.CAP.	
	C 67	QCSB1HJ-270Y	27PF 50V CER.CAP.	
	C 68	QCBB1HK-101Y	100PF 50V CER.CAP.	
	C 69	QFVJ1HJ-105Z	1MF 50V TF.CAPA. I.M	
	C 70	QDXB1CM-392Y	3900PF 16V C CAP.	
	C 71	EETB1CM-476	47MF 16V E.CAP.	
	C 72	QCGB1HK-102	1000PF 50V CER.CAP.	
	C 80	QCBB1HK-820Y	82PF 50V CER.CAP.	
	C 81	QCSB1HJ-470	47PF 50V CER.CAP.	
	C 82	EETC1CM-106ZJC	10MF 16V AL E.CAP.	
	C 83	QCBB1HK-473Y	0.047MF 50V CER.CAP.	
	C 84	QETC1HM-225ZM	2.2MF 50V E.CAP.	
	C 85	QCBB1HK-331Y	330PF 50V CER.CAP.	
	C 86	QCBB1HK-561Y	560PF 50V CER.CAP.	
	C 89	QCGB1HK-102	1000PF 50V CER.CAP.	
	C 90	QDYB1CM-103Y	0.01MF 16V CER.CAP.	
	C 98	QCSB1HJ-100Y	10PF 50V CER.CAP.	
	C110	EETB1HM-105E	1MF 50V E.CAP.	EE
	C111	EETC1HM-335ZJC	3.3MF 50V E.CAP.	EE
	C113	QFP32AJ-103Z	0.01MF 100V PP CAP.	EE
	C114	QFP32AJ-103Z	0.01MF 100V PP CAP.	EE
	C115	QCBB1HK-271Y	270PF 50V CER.CAP.	EE
	C116	QCBB1HK-271Y	270PF 50V CER.CAP.	EE
	C117	EETB1HM-475E	4.7MF 50V E.CAP.	EE
	C118	EETB1HM-475E	4.7MF 50V E.CAP.	EE
	C119	QDXB1CM-222Y	2200PF 16V C CAP.	EE

CA-MXJ55R/CA-MXJ530R

■ Electrical Parts List(Function,Tuner,Main Board)

Block No.02

△	Item	Parts Number	Description	Area
	C120	QDXB1CM-222Y	2200PF 16V C CAP.	EE
	C121	QETN1AM-226Z	22MF 10V E CAP.	EE
	C122	QCS21HJ-221	220PF 50V CER.CAP.	EE
	C123	QCS21HJ-221	220PF 50V CER.CAP.	EE
	C124	QFLM1HJ-103Z	0.01MF 50V M CAP.	EE
	C125	EETB1HM-105E	1MF 50V E.CAP.	EE
	C126	EETB1HM-105E	1MF 50V E.CAP.	EE
	C127	EETB1HM-105E	1MF 50V E.CAP.	EE
	C128	EETC1HM-335ZJC	3.3MF 50V E.CAP.	EE
	C129	EETB1HM-105E	1MF 50V E.CAP.	EE
	C130	EETB1HM-105E	1MF 50V E.CAP.	EE
	C131	EETB1HM-105E	1MF 50V E.CAP.	EE
	C132	EETB1HM-105E	1MF 50V E.CAP.	EE
	C360	QFVJ1HJ-104Z	0.1MF 50V TF CAP.	
	C361	QFVJ1HJ-104Z	0.1MF 50V TF CAP.	
	C365	QETN1CM-227ZS	220MF 16V E.CAP.	
	C366	QETN1AM-108Z	1000MF 10V AL E.CAP.	
	C372	EETB1HM-475E	4.7MF 50V E.CAP.	
	C373	QDYB1CM-103Y	0.01MF 16V CER.CAP.	
	C380	QETC1HM-224Z	0.22MF 50V AL E.CAP.	
	C381	QCFB1HZ-104Y	0.1MF 50V CER.CAP.	
	C382	QCFB1HZ-104Y	0.1MF 50V CER.CAP.	
	C383	QETC1EM-476ZM	47MF 25V E.CAP.	
	C385	EETB1HM-105E	1MF 50V E.CAP.	
	C386	QDGB1HK-681Y	680PF 50V C CAP.	
	C387	QFLM1HJ-153Z	0.015MF 50V M CAP.	
	C388	QDXB1CM-182Y	1800PF 16V C CAP.	
	C389	QCSB1HJ-330Y	33PF 50V CER.CAP.	
	C390	QETC1HM-224Z	0.22MF 50V AL E.CAP.	
	C398	QFLM1HJ-103Z	0.01MF 50V M CAP.	B,E,EN,EV
	C399	QFLM1HJ-103Z	0.01MF 50V M CAP.	B,E,EN,EV
	C401	QFLM1HJ-682Z	6800PF 50V M CAP.	
	C402	QFLM1HJ-682Z	6800PF 50V M CAP.	
	C403	QFLM1HJ-102Z	1000PF 50V MYLAR CAP.	
	C404	QFLM1HJ-102Z	1000PF 50V MYLAR CAP.	
	C407	QTE1V06-106Z	AL E.CAP.	
	C408	QTE1V06-106Z	AL E.CAP.	
	C411	EETB1EM-106E	10MF 25V E.CAP.	
	C412	EETB1EM-106E	10MF 25V E.CAP.	
	C413	QCBB1HK-221Y	220PF 50V CER.CAP.	
	C414	QCBB1HK-221Y	220PF 50V CER.CAP.	
	C415	EETB1EM-106E	10MF 25V E.CAP.	
	C416	EETB1EM-106E	10MF 25V E.CAP.	
	C417	QETC1HM-225ZM	2.2MF 50V E.CAP.	
	C418	QETC1HM-225ZM	2.2MF 50V E.CAP.	
	C419	EETB1EM-106E	10MF 25V E.CAP.	
	C420	QETN1AM-107Z	100MF 10V AL E.CAP.	
	C421	QFVJ1HJ-104Z	0.1MF 50V TF CAP.	
	C422	QFVJ1HJ-104Z	0.1MF 50V TF CAP.	
	C423	QFVJ1HJ-104Z	0.1MF 50V TF CAP.	
	C424	QFVJ1HJ-104Z	0.1MF 50V TF CAP.	
	C425	QFLM1HJ-183Z	0.018MF 50V M CAP.	
	C426	QFLM1HJ-183Z	0.018MF 50V M CAP.	
	C427	QFLM1HJ-223Z	0.022MF 50V M CAP.	
	C428	QFLM1HJ-223Z	0.022MF 50V M CAP.	
	C429	QFLM1HJ-562Z	5600PF 50V MYLAR CAP.	
	C430	QFLM1HJ-562Z	5600PF 50V MYLAR CAP.	
	C431	QETC1HM-225ZM	2.2MF 50V E.CAP.	
	C432	QETC1HM-225ZM	2.2MF 50V E.CAP.	
	C433	QTE1H39-225Z	2.2MF 50V E.CAP.	
	C434	QTE1H39-225Z	2.2MF 50V E.CAP.	
	C435	QETN1EM-106Z	10MF 25V E.CAP.	
	C436	QETN1EM-106Z	10MF 25V E.CAP.	
	C445	QCBB1HK-101Y	100PF 50V CER.CAP.	
	C446	QCBB1HK-101Y	100PF 50V CER.CAP.	
	C447	QTE1C39-106Z	10MF 16V E.CAP.	
	C448	QTE1C39-106Z	10MF 16V E.CAP.	

△	Item	Parts Number	Description	Area
	C453	QCBB1HK-101Y	100PF 50V CER.CAP.	B,E,EN,EV
	C455	QCBB1HK-101Y	100PF 50V CER.CAP.	B,E,EN,EV
	C457	EETB1EM-106E	10MF 25V E.CAP.	
	C458	EETB1EM-106E	10MF 25V E.CAP.	
	C459	QFLM1HJ-333Z	0.033MF 50V MYLAR CAP.	
	C460	EETB1HM-475E	4.7MF 50V E.CAP.	
	C461	QETB1HM-474N	0.47MF 50V E.CAP.	
	C462	QFLM1HJ-393Z	0.039MF 50V M CAP.	
	C463	EETB1HM-475E	4.7MF 50V E.CAP.	
	C464	QETN1AM-107Z	100MF 10V AL E.CAP.	
	C465	QFLM1HJ-473Z	0.047MF 50V M CAP.	
	C466	QFLM1HJ-473Z	0.047MF 50V M CAP.	
	C467	EETB1HM-105E	1MF 50V E.CAP.	
	C468	QETC1EM-476ZM	47MF 25V E.CAP.	
	C477	EETB1HM-475E	4.7MF 50V E.CAP.	
	C481	QDGB1HK-102Y	1000PF 50V CER.CAP.	
	C482	QDGB1HK-102Y	1000PF 50V CER.CAP.	
	C483	QDXB1CM-222Y	2200PF 16V C CAP.	
	C484	QCBB1HK-101Y	100PF 50V CER.CAP.	EE
		QDXB1CM-222Y	2200PF 16V C CAP.	B,E,EN,EV
	C489	EETB1CM-476	47MF 16V E.CAP.	
	C490	EETB1CM-476	47MF 16V E.CAP.	
	C493	QFVJ1HJ-104Z	0.1MF 50V TF CAP.	
	C494	QFVJ1HJ-104Z	0.1MF 50V TF CAP.	
	C495	QFVJ1HJ-104Z	0.1MF 50V TF CAP.	
	C496	QFVJ1HJ-104Z	0.1MF 50V TF CAP.	
	C580	QDX31EM-473Z	0.047MF 25V C CAP.	
	C583	QFLM1HJ-103Z	0.01MF 50V M CAP.	B,E,EN,EV
	C584	QCS31HJ-391Z	390PF 50V C CAP.	B,E,EN,EV
	C586	QFLM1HJ-102Z	1000PF 50V C CAP.	B,E,EN,EV
	C587	EETB1EM-106E	10MF 25V E.CAP.	
	C589	QDYB1CM-103Y	0.01MF 16V CER.CAP.	
		RESISTORS		
	R 1	QRE141J-102Y	1K 1/4W C RES.	
	R 2	QRE141J-121Y	120 1/4W C RES.	EE
		QRE141J-181Y	180 1/4W C RES.	B,E,EN,EV
	R 10	QRE141J-152Y	1.5K 1/4W CARBON RES.	
	R 12	QRE141J-102Y	1K 1/4W C RES.	
	R 13	QRE141J-104Y	100K 1/4W C RES.	
	R 15	QRE141J-103Y	10K 1/4W CARBON RES.	
	R 16	QRE141J-103Y	10K 1/4W CARBON RES.	
	R 19	QRE141J-393Y	39K 1/4W C RES.	
	R 20	QRE141J-331Y	330 1/4W C RES.	
	R 21	QRE141J-224Y	220K 1/4W C RES.	
	R 22	QRE141J-331Y	330 1/4W C RES.	
	R 24	QRE141J-433Y	43K 1/4W C RES.	
	R 25	QRE141J-272Y	2.7K 1/4W C RES.	
	R 26	QRE141J-273Y	27K 1/4W CARBON RES.	
	R 27	QRE141J-393Y	39K 1/4W C RES.	
	R 28	QRE141J-223Y	22K 1/4W C RES.	
	R 29	QRE141J-302Y	3K 1/4W C RES.	
	R 30	QRE141J-392Y	3.9K 1/4W C RES.	
	R 31	QRE141J-200Y	20 1/4W C RES ITM	
	R 32	QRE141J-331Y	330 1/4W C RES.	
	R 33	QRE141J-103Y	10K 1/4W CARBON RES.	
	R 34	QRE141J-222Y	2.2K 1/4W C RES.	
	R 35	QRE141J-222Y	2.2K 1/4W C RES.	
	R 36	QRE141J-103Y	10K 1/4W CARBON RES.	
	R 37	QRE141J-102Y	1K 1/4W C RES.	
	R 43	QRE141J-102Y	1K 1/4W C RES.	
	R 44	QRE141J-102Y	1K 1/4W C RES.	
	R 45	QRE141J-102Y	1K 1/4W C RES.	
	R 46	QRE141J-563Y	56K 1/4W C RES.	
	R 47	QRE141J-103Y	10K 1/4W CARBON RES.	
	R 48	QRE141J-331Y	330 1/4W C RES.	
	R 49	QRE141J-102Y	1K 1/4W C RES.	
	R 52	QRE141J-472Y	4.7K 1/4W C RES.	

■ Electrical Parts List(Function,Tuner,Main Board)

△	Item	Parts Number	Description	Area
	R 54	QRE141J-472Y	4.7K 1/4W C RES.	
	R 55	QRE141J-182Y	1.8K 1/4W C RES.	
	R 56	QRE141J-332Y	3.3K 1/4W C RES.	
	R 57	QRE141J-102Y	1K 1/4W C RES.	
	R 60	QRE141J-102Y	1K 1/4W C RES.	
	R 61	QRE141J-102Y	1K 1/4W C RES.	
	R 64	QRE141J-473Y	47K 1/4W C RES.	
	R 65	QRE141J-222Y	2.2K 1/4W C RES.	
	R 66	QRE141J-222Y	2.2K 1/4W C RES.	
	R 69	QRE141J-103Y	10K 1/4W CARBON RES.	
	R 76	QRE141J-102Y	1K 1/4W C RES.	
	R 80	QRE141J-222Y	2.2K 1/4W C RES.	
	R 82	QRE141J-102Y	1K 1/4W C RES.	
	R 83	QRE141J-102Y	1K 1/4W C RES.	
	R 84	QRE141J-103Y	10K 1/4W CARBON RES.	
	R 91	QRE141J-103Y	10K 1/4W CARBON RES.	
	R 99	QRE141J-102Y	1K 1/4W C RES.	EE
	R101	QRE141J-271Y	270 1/4W C RES.	
	R102	QRE141J-391Y	390 1/4W C RES.	
	R110	QRE141J-123Y	12K 1/4W C RES.	EE
	R111	QRE141J-563Y	56K 1/4W C RES.	EE
	R112	QRE141J-103Y	10K 1/4W CARBON RES.	EE
	R113	QRE141J-563Y	56K 1/4W C RES.	EE
	R114	QRE141J-562Y	5.6K 1/4W C RES.	EE
	R115	QRE141J-184Y	180K 1/4W C RES.	EE
	R116	QRE141J-224Y	220K 1/4W C RES.	EE
	R117	QRE141J-623Y	62K 1/4W C RES.	EE
	R118	QRE141J-103Y	10K 1/4W CARBON RES.	EE
	R119	QRE141J-224Y	220K 1/4W C RES.	EE
	R120	QRE141J-224Y	220K 1/4W C RES.	EE
	R121	QRE141J-333Y	33K 1/4W C RES.	EE
	R122	QRE141J-224Y	220K 1/4W C RES.	EE
	R123	QRE141J-224Y	220K 1/4W C RES.	EE
	R124	QRE141J-103Y	10K 1/4W CARBON RES.	EE
	R125	QRE141J-103Y	10K 1/4W CARBON RES.	EE
	R126	QRE141J-333Y	33K 1/4W C RES.	EE
	R127	QRE141J-473Y	47K 1/4W C RES.	EE
	R128	QRE141J-473Y	47K 1/4W C RES.	EE
	R129	QRE141J-104Y	100K 1/4W C RES.	EE
	R130	QRE141J-104Y	100K 1/4W C RES.	EE
	R131	QRE141J-473Y	47K 1/4W C RES.	EE
	R132	QRE141J-102Y	1K 1/4W C RES.	EE
	R133	QRE141J-274Y	270K 1/4W C RES.	EE
	R134	QRE141J-274Y	270K 1/4W C RES.	EE
	R135	QRE141J-184Y	180K 1/4W C RES.	EE
	R136	QRE141J-184Y	180K 1/4W C RES.	EE
	R137	QRE141J-224Y	220K 1/4W C RES.	EE
	R138	QRE141J-224Y	220K 1/4W C RES.	EE
	R360	QRE141J-222Y	2.2K 1/4W C RES.	
	R362	QRE141J-221Y	220 1/4W C RES.	
	R363	QRE141J-391Y	390 1/4W C RES.	
	R370	QRE141J-102Y	1K 1/4W C RES.	
	R371	QRE141J-103Y	10K 1/4W CARBON RES.	
	R372	QRE141J-103Y	10K 1/4W CARBON RES.	
	R375	QRE141J-331Y	330 1/4W C RES.	
	R376	QRE141J-473Y	47K 1/4W C RES.	
	R378	QRE141J-104Y	100K 1/4W C RES.	
	R383	QRE141J-472Y	4.7K 1/4W C RES.	
	R384	QRE141J-472Y	4.7K 1/4W C RES.	
	R386	QRE141J-104Y	100K 1/4W C RES.	
	R387	QRE141J-473Y	47K 1/4W C RES.	
	R388	QRE141J-220Y	22 1/4W CARBON RES.	
	R389	QRE141J-225Y	2.2M 1/4W C RES.	
	R401	QRE141J-222Y	2.2K 1/4W C RES.	
	R402	QRE141J-222Y	2.2K 1/4W C RES.	
	R403	QRE141J-222Y	2.2K 1/4W C RES.	
	R404	QRE141J-222Y	2.2K 1/4W C RES.	

△	Item	Parts Number	Description	Area
	R405	QRE141J-432Y	4.3K 1/4W C RES.	
	R406	QRE141J-432Y	4.3K 1/4W C RES.	
	R407	QRE141J-302Y	3K 1/4W C RES.	
	R408	QRE141J-302Y	3K 1/4W C RES.	
	R413	QRE141J-303Y	30K 1/4W C RES.	
	R414	QRE141J-303Y	30K 1/4W C RES.	
	R415	QRE141J-303Y	30K 1/4W C RES.	
	R416	QRE141J-303Y	30K 1/4W C RES.	
	R417	QRE141J-562Y	5.6K 1/4W C RES.	
	R418	QRE141J-562Y	5.6K 1/4W C RES.	
	R419	QRE141J-272Y	2.7K 1/4W C RES.	
	R420	QRE141J-272Y	2.7K 1/4W C RES.	
	R421	QRE141J-104Y	100K 1/4W C RES.	
	R422	QRE141J-104Y	100K 1/4W C RES.	
	R433	QRE141J-562Y	5.6K 1/4W C RES.	
	R434	QRE141J-562Y	5.6K 1/4W C RES.	
	R435	QRE141J-104Y	100K 1/4W C RES.	
	R436	QRE141J-104Y	100K 1/4W C RES.	
	R437	QRE141J-472Y	4.7K 1/4W C RES.	
	R438	QRE141J-472Y	4.7K 1/4W C RES.	
	R439	QRE141J-472Y	4.7K 1/4W C RES.	
	R440	QRE141J-472Y	4.7K 1/4W C RES.	
	R441	QRE141J-104Y	100K 1/4W C RES.	
	R442	QRE141J-104Y	100K 1/4W C RES.	
	R445	QRE141J-303Y	30K 1/4W C RES.	
	R446	QRE141J-303Y	30K 1/4W C RES.	
	R450	QRE141J-224Y	220K 1/4W C RES.	
	R459	QRE141J-472Y	4.7K 1/4W C RES.	
	R460	QRE141J-472Y	4.7K 1/4W C RES.	
	R461	QRE141J-222Y	2.2K 1/4W C RES.	
	R462	QRE141J-222Y	2.2K 1/4W C RES.	
	R463	QRE141J-103Y	10K 1/4W CARBON RES.	
	R464	QRE141J-103Y	10K 1/4W CARBON RES.	
	R465	QRE141J-102Y	1K 1/4W C RES.	
	R469	QRE141J-221Y	220 1/4W C RES.	
	R470	QRE141J-221Y	220 1/4W C RES.	
	R471	QRE141J-103Y	10K 1/4W CARBON RES.	
	R472	QRE141J-103Y	10K 1/4W CARBON RES.	
	R473	QRE141J-103Y	10K 1/4W CARBON RES.	
	R481	QRE141J-222Y	2.2K 1/4W C RES.	
	R482	QRE141J-222Y	2.2K 1/4W C RES.	
	R483	QRE141J-221Y	220 1/4W C RES.	
	R484	QRE141J-221Y	220 1/4W C RES.	
	R485	QRE141J-103Y	10K 1/4W CARBON RES.	
	R486	QRE141J-103Y	10K 1/4W CARBON RES.	
	R493	QRE141J-123Y	12K 1/4W C RES.	
	R494	QRE141J-123Y	12K 1/4W C RES.	
	R497	QRE141J-104Y	100K 1/4W C RES.	
	R498	QRE141J-104Y	100K 1/4W C RES.	
	R546	QRE141J-473Y	47K 1/4W C RES.	
	R547	QRE141J-473Y	47K 1/4W C RES.	
	R548	QRE141J-563Y	56K 1/4W C RES.	
	R549	QRE141J-563Y	56K 1/4W C RES.	
	R555	QRE141J-102Y	1K 1/4W C RES.	
	R556	QRE141J-102Y	1K 1/4W C RES.	
	R573	QRE141J-103Y	10K 1/4W CARBON RES.	
	R576	QRE141J-102Y	1K 1/4W C RES.	
	R578	QRE141J-103Y	10K 1/4W CARBON RES.	
	R579	QRE141J-102Y	1K 1/4W C RES.	
	R580	QRE141J-103Y	10K 1/4W CARBON RES.	
	R581	QRE141J-102Y	1K 1/4W C RES.	
	R582	QRE141J-102Y	1K 1/4W C RES.	
	R583	QRE141J-102Y	1K 1/4W C RES.	
	R584	QRE141J-102Y	1K 1/4W C RES.	
	R585	QRE141J-102Y	1K 1/4W C RES.	
	R586	QRE141J-103Y	10K 1/4W CARBON RES.	
	R587	QRE141J-102Y	1K 1/4W C RES.	

CA-MXJ55R/CA-MXJ530R

■ Electrical Parts List(Function, Tuner, Main Board)

Block No.02

△	Item	Parts Number	Description	Area
	R588	QRE141J-103Y	10K 1/4W CARBON RES.	
	R589	QRE141J-102Y	1K 1/4W C RES.	
	R592	QRE141J-102Y	1K 1/4W C RES.	
	R593	QRE141J-272Y	2.7K 1/4W C RES.	
	R594	QRE141J-181Y	180 1/4W C RES.	
	R595	QRE141J-181Y	180 1/4W C RES.	
	R597	QRE141J-222Y	2.2K 1/4W C RES.	
	R599	QRE141J-222Y	2.2K 1/4W C RES.	
	VR100	QVP0004-203Z	20K V.RES. I.M	EE
		OTHERS		
	J 1	QNB0014-001	ANT TERMINAL	
	J401	QNN0132-001	PIN JACK	
	J499	GP1F32T	OPTICAL JACK	
	L 1	QQR0884-001	COIL BLOCK	
	L 4	QQL231K-221Y	INDUCTOR	
	L 5	QQL231K-101Y	INDUCTOR	
	L 11	QQL231K-2R7Y	INDUCTOR	
	L 12	QQL231K-330Y	INDUCTOR	B,E,EN,EV
	L100	QQR0522-001	NOISE FILTER	EE
	L403	QQR0779-001Z	INDUCTOR	B,E,EN,EV
	L405	QQR0779-001Z	INDUCTOR	B,E,EN,EV
	L406	QQR0779-001Z	INDUCTOR	B,E,EN,EV
	T 1	QQR0793-001	IFT	
	X 1	QAX0402-001	CRYSTAL	
	X 2	QAX0263-001Z	CRYSTAL	
	CF 1	QAX0403-001	CERAMIC FILTER	EE
		QAX0420-001	C FILTER	B,E,EN,EV
	CF 2	QAX0403-001	CERAMIC FILTER	EE
		QAX0421-001	C FILTER	B,E,EN,EV
	CF 3	QAX0519-001Z	CERAMIC FILTER	
	CN410	QGF1016F1-19	CONNECTOR	
	CN411	QGF1201C3-21	CONNECT TERMINAL	
	CN412	QGF1201C3-21	CONNECT TERMINAL	
	CN413	QGF1201C3-17	CONNECT TERMINAL	
	CN415	QGD2501C1-04Z	SOCKET ASSY	
	CN416	QGB2501J1-10	CONNECT TERMINAL	
	CN417	QGB2501J1-07	CONNECT TERMINAL	
	CN420	QGB2501J1-10	CONNECT TERMINAL	EE
	CN421	QGB2501K2-10	CONNECT TERMINAL	EE
	EP001	E409182-001SM	EARTH TERMINAL	
	TH401	QAD0064-2R2Z	POSISTOR I.M	
	TU 1	QAU0034-001	FM FRONT END	B,E,EN,EV
		QAU0036-001	FM FRONT END	EE

■ Electrical Parts List(System Control & Switch Board)

Block No.03

△	Item	Parts Number	Description	Area
		I.C.S		
	IC810	MN101C23DBP	I.C(M)	
	IC811	NJU3714D	I.C(M)	
	IC812	GP1U291Q	I.C(M)	
	IC853	TA8409S	I.C(MONO-ANALOG)	
	IC854	NJU3711D	I.C(MONO-ANALOG)	
		DIODES		
	D801	1SR35-100A-T5	SI DIODE	
	D803	1SS119-02-T2	SI DIODE	
	D804	1SS133-T2	SI.DIODE	
	D831	MTZJ5.1A-T2	SI.DIODE	
	D832	MTZJ5.1A-T2	SI.DIODE	
	D920	SLR-342DC-T	L.E.D.	
	D955	SLR-342MC-T	LED I.M	
	D956	SLR-342MC-T	LED I.M	
	D957	SLR-342MC-T	LED I.M	
	D958	SLR-342MC-T	LED I.M	
	D961	1SS133-T2	SI.DIODE	
	D962	SLR-342VC-T	L.E.D.	
	D981	SLR-342MC-T	LED I.M	
	D982	SLR-342MC-T	LED I.M	
	D983	SLR-342MC-T	LED I.M	
	D984	SLR-342MC-T	LED I.M	
	D991	SLR-342MC-T	LED I.M	
	D992	SLR-342MC-T	LED I.M	
	D993	SLR-342MC-T	LED I.M	
	D1041	1SS133-T2	SI.DIODE	
		TRANSISTORS		
	Q801	2SC2668/O-T	TRANSISTOR TAPE	
	Q802	2SC2668/O-T	TRANSISTOR TAPE	
	Q803	DTC114ES	DIGITAL TRANSISTOR	
	Q804	DTC114ES	DIGITAL TRANSISTOR	
	Q805	DTC114ES	DIGITAL TRANSISTOR	
	Q806	DTC114ES	DIGITAL TRANSISTOR	
	Q807	DTC114ES	DIGITAL TRANSISTOR	
	Q808	DTC114ES	DIGITAL TRANSISTOR	
	Q809	DTC114ES	DIGITAL TRANSISTOR	
	Q810	DTC114ES	DIGITAL TRANSISTOR	
	Q811	DTC114ES	DIGITAL TRANSISTOR	
	Q851	KTC3199/GL-T	TR I/M	
	Q961	KRA102M-T	DIGITAL TRANSISTOR	
		CAPACITORS		
	C801	QFVJ1HJ-124Z	0.12MF 50V TF CAP.	
	C803	QETC0JM-477ZM	470MF 6.3V E.CAP.	
	C804	QETN0JM-108Z	1000MF 6.3V AL E.CAP.	
	C805	QCGB1HK-102	1000PF 50V CER.CAP.	
	C806	QCGB1HK-102	1000PF 50V CER.CAP.	
	C807	QCSB1HJ-390Y	39PF 50V CER.CAP.	
	C808	QCSB1HJ-330Y	33PF 50V CER.CAP.	
	C809	QCSB1HJ-330Y	33PF 50V CER.CAP.	
	C810	QCSB1HJ-390Y	39PF 50V CER.CAP.	
	C811	QCGB1HK-102	1000PF 50V CER.CAP.	
	C812	QCSB1HJ-220	22PF 50V CER.CAP.	
	C813	QCSB1HJ-270Y	27PF 50V CER.CAP.	
	C814	QCGB1HK-102	1000PF 50V CER.CAP.	
	C815	EETC1HM-226ZJC	22MF 50V E.CAPA. I.M	
	C816	EETB1CM-476	47MF 16V E.CAP.	
	C817	EETC1HM-226ZJC	22MF 50V E.CAPA. I.M	
	C818	QCBB1HK-221Y	220PF 50V CER.CAP.	
	C819	QCBB1HK-221Y	220PF 50V CER.CAP.	
	C820	QCZ0205-155	1.5MF 25V C.CAP.	
	C821	QDYB1CM-103Y	0.01MF 16V CER.CAP.	
	C831	QDYB1CM-103Y	0.01MF 16V CER.CAP.	
	C832	QDYB1CM-103Y	0.01MF 16V CER.CAP.	
	C834	QEK0JM-226Z	22MF 16V CER.CAP.	
	C851	EETB1EM-106E	10MF 25V E.CAP.	
	C852	QCBB1HK-221Y	220PF 50V CER.CAP.	

△	Item	Parts Number	Description	Area
	C853	QCBB1HK-221Y	220PF 50V CER.CAP.	
	C854	EETC1EM-226ZE	22MF 25V E.CAP.	
	C855	QETB0JM-227	220MF 6.3V E.CAP.	
	C856	QETN1AM-107Z	100MF 10V AL E.CAP.	
	C857	EETC1CM-476ZJC	47MF 50V AL E.CAP.	
	C858	QCBB1HK-221Y	220PF 50V CER.CAP.	B,E,EN,EV
	C859	QCBB1HK-221Y	220PF 50V CER.CAP.	B,E,EN,EV
	C860	QFLM1HJ-103Z	0.01MF 50V CER.CAP.	B,E,EN,EV
	C971	QDYB1CM-103Y	0.01MF 16V CER.CAP.	
	C972	QDYB1CM-103Y	0.01MF 16V CER.CAP.	
	C1001	QCGB1HK-102	1000PF 50V CER.CAP.	B,E,EN,EV
	C1002	QCGB1HK-102	1000PF 50V CER.CAP.	B,E,EN,EV
	C1003	QDGB1HK-102Y	1000PF 50V CER.CAP.	B,E,EN,EV
	C1004	QCGB1HK-102	1000PF 50V CER.CAP.	
	C1005	QCGB1HK-102	1000PF 50V CER.CAP.	
	C1006	QCGB1HK-102	1000PF 50V CER.CAP.	
	C1051	QFVJ1HJ-104Z	0.1MF 50V TF CAP.	
	C1052	QFVJ1HJ-104Z	0.1MF 50V TF CAP.	
	C1053	QDXB1CM-222Y	2200PF 16V C CAP.	
	C1054	QDXB1CM-222Y	2200PF 16V C CAP.	
	C1055	QFLM1HJ-393Z	0.039MF 50V M CAP.	
	C1056	QFLM1HJ-393Z	0.039MF 50V M CAP.	
		RESISTORS		
	R801	QRE141J-331Y	330 1/4W C RES.	
	R802	QRE141J-223Y	22K 1/4W C RES.	
	R803	QRE141J-223Y	22K 1/4W C RES.	
	R804	QRE141J-822Y	8.2K 1/4W C RES.	
	R805	QRE141J-822Y	8.2K 1/4W C RES.	
	R806	QRE141J-124Y	120K 1/4W C RES.	
	R807	QRE141J-103Y	10K 1/4W CARBON RES.	
	R808	QRE141J-103Y	10K 1/4W CARBON RES.	
	R809	QRE141J-103Y	10K 1/4W CARBON RES.	
	R810	QRE141J-103Y	10K 1/4W CARBON RES.	
	R811	QRE141J-103Y	10K 1/4W CARBON RES.	
	R812	QRE141J-103Y	10K 1/4W CARBON RES.	
	R813	QRE141J-103Y	10K 1/4W CARBON RES.	
	R814	QRE141J-103Y	10K 1/4W CARBON RES.	
	R815	QRE141J-563Y	56K 1/4W C RES.	
	R816	QRE141J-563Y	56K 1/4W C RES.	
	R817	QRE141J-103Y	10K 1/4W CARBON RES.	
	R818	QRE141J-103Y	10K 1/4W CARBON RES.	
	R819	QRE141J-102Y	1K 1/4W C RES.	
	R820	QRE141J-102Y	1K 1/4W C RES.	
	R821	QRE141J-102Y	1K 1/4W C RES.	
	R822	QRE141J-102Y	1K 1/4W C RES.	
	R823	QRE141J-102Y	1K 1/4W C RES.	
	R824	QRE141J-102Y	1K 1/4W C RES.	
	R825	QRE141J-102Y	1K 1/4W C RES.	
	R826	QRE141J-102Y	1K 1/4W C RES.	
	R827	QRE141J-103Y	10K 1/4W CARBON RES.	
	R828	QRE141J-201Y	200 1/4W C.RES. I.M	
	R829	QRE141J-201Y	200 1/4W C.RES. I.M	
	R830	QRE141J-201Y	200 1/4W C.RES. I.M	
	R831	QRE141J-104Y	100K 1/4W C RES.	
	R832	QRE141J-104Y	100K 1/4W C RES.	
	R833	QRE141J-104Y	100K 1/4W C RES.	
	R834	QRE141J-104Y	100K 1/4W C RES.	
	R835	QRE141J-104Y	100K 1/4W C RES.	
	R836	QRE141J-104Y	100K 1/4W C RES.	
	R837	QRE141J-104Y	100K 1/4W C RES.	
	R838	QRE141J-102Y	1K 1/4W C RES.	
	R839	QRE141J-102Y	1K 1/4W C RES.	
	R840	QRE141J-103Y	10K 1/4W CARBON RES.	
	R841	QRE141J-103Y	10K 1/4W CARBON RES.	
	R842	QRE141J-103Y	10K 1/4W CARBON RES.	
	R843	QRE141J-103Y	10K 1/4W CARBON RES.	
	R844	QRE141J-103Y	10K 1/4W CARBON RES.	

CA-MXJ55R/CA-MXJ530R

■ Electrical Parts List(System Control & Switch Board)

Block No.03

△	Item	Parts Number	Description	Area
	R845	QRE141J-102Y	1K 1/4W C RES.	
	R846	QRE141J-102Y	1K 1/4W C RES.	
	R847	QRE141J-102Y	1K 1/4W C RES.	
	R848	QRE141J-102Y	1K 1/4W C RES.	
	R849	QRE141J-102Y	1K 1/4W C RES.	
	R850	QRE141J-103Y	10K 1/4W C RES.	
	R851	QRE141J-562Y	5.6K 1/4W C RES.	
	R852	QRE141J-3R9Y	3.9 1/4W C RES.	
	R853	QRE141J-183Y	18K 1/4W CARBON RES.	
	R854	QRE141J-332Y	3.3K 1/4W C RES.	
	R856	QRE141J-151Y	150 1/4W C RES.	
	R857	QRE141J-391Y	390 1/4W C.RES. I.M	
	R920	QRE141J-391Y	390 1/4W C.RES. I.M	
	R921	QRE141J-102Y	1K 1/4W C RES.	
	R922	QRE141J-102Y	1K 1/4W C RES.	
	R923	QRE141J-122Y	1.2K 1/4W C RES.	
	R924	QRE141J-152Y	1.5K 1/4W CARBON RES.	
	R925	QRE141J-222Y	2.2K 1/4W C RES.	
	R926	QRE141J-272Y	2.7K 1/4W C RES.	
	R927	QRE141J-392Y	3.9K 1/4W C RES.	
	R928	QRE141J-562Y	5.6K 1/4W C RES.	
	R931	QRE141J-102Y	1K 1/4W C RES.	
	R932	QRE141J-102Y	1K 1/4W C RES.	
	R933	QRE141J-122Y	1.2K 1/4W C RES.	
	R934	QRE141J-152Y	1.5K 1/4W CARBON RES.	
	R935	QRE141J-222Y	2.2K 1/4W C RES.	
	R936	QRE141J-272Y	2.7K 1/4W C RES.	
	R937	QRE141J-392Y	3.9K 1/4W C RES.	
	R938	QRE141J-562Y	5.6K 1/4W C RES.	
	R939	QRE141J-103Y	10K 1/4W CARBON RES.	
	R940	QRE141J-563Y	56K 1/4W C RES.	B,E,EN,EV
	R941	QRE141J-102Y	1K 1/4W C RES.	
	R942	QRE141J-102Y	1K 1/4W C RES.	
	R943	QRE141J-122Y	1.2K 1/4W C RES.	
	R944	QRE141J-152Y	1.5K 1/4W CARBON RES.	
	R945	QRE141J-153Y	15K 1/4W C RES.	
	R946	QRE141J-103Y	10K 1/4W CARBON RES.	
	R947	QRE141J-563Y	56K 1/4W C RES.	EE
	R948	QRE141J-104Y	100K 1/4W C RES.	
	R949	QRE141J-104Y	100K 1/4W C RES.	
	R951	QRE141J-102Y	1K 1/4W C RES.	
	R952	QRE141J-103Y	10K 1/4W CARBON RES.	
	R953	QRE141J-183Y	18K 1/4W CARBON RES.	
	R955	QRE141J-201Y	200 1/4W C.RES. I.M	
	R956	QRE141J-201Y	200 1/4W C.RES. I.M	
	R957	QRE141J-201Y	200 1/4W C.RES. I.M	
	R958	QRE141J-201Y	200 1/4W C.RES. I.M	
	R961	QRE141J-201Y	200 1/4W C.RES. I.M	
	R962	QRE141J-472Y	4.7K 1/4W C RES.	
	R963	QRE141J-102Y	1K 1/4W C RES.	
	R964	QRE141J-122Y	1.2K 1/4W C RES.	
	R981	QRE141J-201Y	200 1/4W C.RES. I.M	
	R982	QRE141J-201Y	200 1/4W C.RES. I.M	
	R983	QRE141J-201Y	200 1/4W C.RES. I.M	
	R984	QRE141J-201Y	200 1/4W C.RES. I.M	
	R985	QRE141J-103Y	10K 1/4W CARBON RES.	
	R986	QRE141J-183Y	18K 1/4W CARBON RES.	
	R992	QRE141J-152Y	1.5K 1/4W CARBON RES.	
	R993	QRE141J-222Y	2.2K 1/4W C RES.	
	R994	QRE141J-272Y	2.7K 1/4W C RES.	
	R995	QRE141J-392Y	3.9K 1/4W C RES.	
	R996	QRE141J-562Y	5.6K 1/4W C RES.	
	RA801	QRB169J-104	100K 1/10WRES. ARR	
	RA802	QRB169J-104	100K 1/10WRES. ARR	
	R1026	QRE141J-683Y	68K 1/4W C RES.	
	R1035	QRE141J-393Y	39K 1/4W C RES.	
△	R1051	QRJ146J-4R7X	4.7 1/4W UNF.CARBON R	

△	Item	Parts Number	Description	Area
△	R1052	QRJ146J-4R7X	4.7 1/4W UNF.CARBON R	
	R1053	QRE141J-393Y	39K 1/4W C RES.	
	R1054	QRE141J-393Y	39K 1/4W C RES.	
	R1055	QRE141J-102Y	1K 1/4W C RES.	
		OTHERS		
		E3400-439	FELT SPACER	
		GV30032-001A	FL HOLDER	
	J 81	QNB0038-001	SPK.TERMINAL	EE
		QNB0088-001	SPEAKER TERMINAL	B,E,EN,EV
	J 82	QNN0017-001	PIN JACK	
	L801	QQL173K-470Z	INDUCTOR	
	L802	QQL231K-220Y	INDUCTOR	
	L803	QQL29BJ-100Z	INDUCTOR	
	L805	QQL173K-470Z	INDUCTOR	
	L806	QQL173K-470Z	INDUCTOR	
	L851	QQL29BJ-100Z	INDUCTOR	
	L852	QQR0779-001Z	INDUCTOR	
	L853	QQR0779-001Z	INDUCTOR	B,E,EN,EV
	L1003	QQR0779-001Z	INDUCTOR	B,E,EN,EV
	S921	QSW0674-001Z	TACT SWITCH	
	S922	QSW0674-001Z	TACT SWITCH	
	S923	QSW0674-001Z	TACT SWITCH	
	S924	QSW0674-001Z	TACT SWITCH	
	S925	QSW0674-001Z	TACT SWITCH	
	S926	QSW0674-001Z	TACT SWITCH	
	S927	QSW0674-001Z	TACT SWITCH	
	S928	QSW0674-001Z	TACT SWITCH	
	S931	QSW0674-001Z	TACT SWITCH	
	S932	QSW0674-001Z	TACT SWITCH	
	S933	QSW0674-001Z	TACT SWITCH	
	S934	QSW0674-001Z	TACT SWITCH	
	S935	QSW0674-001Z	TACT SWITCH	
	S936	QSW0674-001Z	TACT SWITCH	
	S937	QSW0674-001Z	TACT SWITCH	
	S938	QSW0674-001Z	TACT SWITCH	
	S939	QSW0674-001Z	TACT SWITCH	
	S941	QSW0674-001Z	TACT SWITCH	
	S942	QSW0674-001Z	TACT SWITCH	
	S943	QSW0674-001Z	TACT SWITCH	
	S944	QSW0674-001Z	TACT SWITCH	
	S945	QSW0674-001Z	TACT SWITCH	
	S946	QSW0674-001Z	TACT SWITCH	
	S948	QSW0518-001	PUSH SWITCH	
	S949	QSW0518-001	PUSH SWITCH	
	S951	QSW0674-001Z	TACT SWITCH	
	S952	QSW0674-001Z	TACT SWITCH	
	S953	QSW0674-001Z	TACT SWITCH	
	S963	QSW0674-001Z	TACT SWITCH	
	S985	QSW0674-001Z	TACT SWITCH	
	S986	QSW0674-001Z	TACT SWITCH	
	S992	QSW0674-001Z	TACT SWITCH	
	S993	QSW0674-001Z	TACT SWITCH	
	S994	QSW0674-001Z	TACT SWITCH	
	S995	QSW0674-001Z	TACT SWITCH	
	S996	QSW0674-001Z	TACT SWITCH	
	S997	QSW0674-001Z	TACT SWITCH	
	X801	QAX0416-001Z	CERA LOCK	
	X802	QAX0401-001	CRYSTAL	
	CN115	QGB2510K2-06	CONNECTOR	
	CN810	QGF1201F3-21	VMC0332-R21	
	CN811	QGF1201F3-23	CONNECTOR	
	CN812	QGF1201F3-11	CONNECTOR	
	CN813	QGF1016F1-09	CONNECT TERMINAL	
	CN814	QGD2501C1-04Z	SOCKET ASSY	
	CN815	QGD2501C1-03Z	SOCKET ASSY	
	CN816	QGD2501C1-05Z	SOCKET ASSY	
	CN817	QGF1201C3-10	CONNECTOR	

■ Electrical Parts List(System Control & Switch Board)

品番	Item	Parts Number	Description	Area
	CN856	QGF1201C3-21	CONNECT TERMINAL	
	CN857	QGF1201C3-23	CONNECTOR	
	CN858	QGD2501C1-05Z	SOCKET ASSY	B,E,EN,EV
	CN859	QGF1201C3-10	CONNECTOR	
	CN860	QGF1201C3-21	CONNECT TERMINAL	
	CN861	QGF1201C3-17	CONNECT TERMINAL	
	CN862	QGF1201C3-21	CONNECT TERMINAL	
	CN863	EMV5111-002	2P CONNECTOR	
	CN921	QGF1016F1-09	CONNECT TERMINAL	
	CN971	QGF1201F3-10	CONNECTOR	
	FL801	QLF0059-001	FL TUBE	
	FW901	QUM134-34DGZ4	FLAT WIRE	
	FW951	QUM027-08DGZ3	FLAT WIRE	
	FW961	QUM025-14DGZ3	FLAT WIRE	
	FW971	QUM026-07Z3Z3	FLAT WIRE	
	FW972	QUM025-07Z3Z3	FLAT WIRE	
	JS971	QSW0538-001	ROTARY SWITCH	
	J1001	QNS0030-001	JACK	
	L1001	QQL231K-470Y	INDUCTOR	B,E,EN,EV
	L1002	QQL231K-470Y	INDUCTOR	B,E,EN,EV
	L1003	QQL231K-2R2Y	INDUCTOR I.M	
	RY 1	QSK0057-001	RELAY	
	SP801	VYH7653-001	I.C.PROTECTOR	

Electrical Parts List (CD Servo Control Board)

BLOCK NO. 04				BLOCK NO. 05					
REF.	PARTS NO.	PARTS NAME	REMARKS	SUFFIX	REF.	PARTS NO.	PARTS NAME	REMARKS	SUFFIX
C 251	NCS21HJ-100X	C CAPACITOR	10PF 5X 50V		C 851	GER41CM-106	E CAPACITOR	10MF 20X 16V	
C 252	NCS21HJ-100X	C CAPACITOR	10PF 5X 50V		C 852	GER41CM-106	E CAPACITOR	10MF 20X 16V	
C 253	NCB21EK-104X	C CAPACITOR	10MF 10X 25V		C 853	NCB21EK-104X	C CAPACITOR	10MF 10X 25V	
C 254	QER41AM-474Z	E CAPACITOR	47MF 20X 10V		C 850	NCF21CZ-105X	C CAPACITOR	1.0MF +80:-20X	
C 255	NCB21EK-104X	C CAPACITOR	1.0MF 10X 25V		C 851	NCF21CZ-105X	C CAPACITOR	1.0MF +80:-20X	
C 256	NCB21EK-104X	C CAPACITOR	1.0MF 10X 25V		CN31	GGF1016F1-15	15FFC CONNECTOR	VIDEO CD	
C 291	QER41AM-476Z	E CAPACITOR	47MF 20X 10V		CN42	GGF2001F1-12	12P CM RIG	VIDEO CD	
C 601	NCB21HK-102X	C CAPACITOR	1000PF 10X 50V		CN501	GGF1016F1-15	15FFC CONNECTOR	TRAVERSE	
C 602	NCB21HK-102X	C CAPACITOR	1000PF 10X 50V		CN51	GGF1016F1-19	CONNECTOR	MAIN	
C 603	NCB21HK-102X	C CAPACITOR	1000PF 10X 50V		CN52	GGF1016F1-05	CONNECTOR	OSD	
C 604	NCB21HK-223X	C CAPACITOR	0.22MF 10X 50V		CN53	GGF1016F1-13	CONNECTOR	CD TEXT	
C 605	NCS21HJ-271X	C CAPACITOR	270PF 5X 50V		CN801	GGF2001C1-06	6P PLUG ASSY	TRAVERSE	
C 606	NCS21HJ-181X	C CAPACITOR	180PF 5X 50V		CN851	GGD2030F1-03	SOCKET	DISC DETECTION	
C 607	NCB21HK-222X	C CAPACITOR	2200PF 10X 50V		CN854	GGB2016K1-07	CONNECTOR	TRAY SWITCH	
C 608	NCB21HK-223X	C CAPACITOR	0.22MF 10X 50V		CN855	GGB2012K2-10	CONNECTOR	CAM SWITCH	
C 610	NCB21EK-104X	C CAPACITOR	1.0MF 10X 25V		IC251	UPD78055GCA37	IC	MICOM	
C 611	NCB21EK-104X	C CAPACITOR	1.0MF 10X 25V		IC501	AN8804SB-W	IC	RF AMP	
C 612	QER41HM-105	E CAPACITOR	1.0MF 20X 50V		IC501	MN35510	IC	DSP & DAC	
C 613	NCS21HJ-101X	C CAPACITOR	100PF 5X 50V		IC801	BA6897FP-W	IC	PU DRIVE	
C 614	NCB21HK-273X	C CAPACITOR	0.27MF 10X 50V		IC851	TAB409S	IC	L MOTOR DRIVE	
C 615	NCB21HK-472X	C CAPACITOR	4700PF 10X 50V		IC852	TAB409S	IC	R MOTOR DRIVE	
C 616	NCB21HK-103X	C CAPACITOR	0.10MF 10X 50V		L 851	GL01BK-100Z	INDUCTOR	VS DE-COUPLE	
C 617	NCS21HJ-331X	C CAPACITOR	330PF 5X 50V		L 853	GL01BK-100Z	INDUCTOR	L MOTOR	
C 621	NCB21EK-104X	C CAPACITOR	1.0MF 10X 25V		L 854	GL01BK-100Z	INDUCTOR	R MOTOR	
C 622	NCF21CZ-105X	C CAPACITOR	1.0MF +80:-20X		Q 291	25B1357/EF-T	TRANSISTOR	/P.ON	
C 624	QER41AM-107	E CAPACITOR	100PF 5X 50V		Q 631	25A1037AK7RS/-X	TRANSISTOR	APC	
C 631	QER41CM-106	E CAPACITOR	10MF 20X 16V		Q 642	DTA144ES-T	TRANSISTOR	/DISC	
C 632	NCF21CZ-105X	C CAPACITOR	1.0MF +80:-20X		R 251	NRSA02J-102X	MG RESISTOR	1.0K 5X 1/10W	
C 633	NCB21HK-223X	C CAPACITOR	0.22MF 10X 50V		R 252	NRSA02J-102X	MG RESISTOR	1.0K 5X 1/10W	
C 651	NCS21HJ-120X	C CAPACITOR	12PF 5X 50V		R 253	NRSA02J-102X	MG RESISTOR	1.0K 5X 1/10W	
C 652	NCS21HJ-120X	C CAPACITOR	12PF 5X 50V		R 254	NRSA02J-102X	MG RESISTOR	1.0K 5X 1/10W	
C 653	NCB21EK-104X	C CAPACITOR	1.0MF 10X 25V		R 255	NRSA02J-102X	MG RESISTOR	1.0K 5X 1/10W	
C 654	NCB21HK-223X	C CAPACITOR	0.22MF 10X 50V		R 256	NRSA02J-102X	MG RESISTOR	1.0K 5X 1/10W	
C 655	QER41AM-247	E CAPACITOR	220MF 20X 10V		R 257	NRSA02J-102X	MG RESISTOR	1.0K 5X 1/10W	
C 656	NCB21EK-104X	C CAPACITOR	1.0MF 10X 25V		R 258	NRSA02J-102X	MG RESISTOR	1.0K 5X 1/10W	
C 657	NCB21HK-222X	C CAPACITOR	2200PF 10X 50V		R 259	NRSA02J-101X	MG RESISTOR	100 5X 1/10W	
C 658	NCB21HK-222X	C CAPACITOR	2200PF 10X 50V		R 260	NRSA02J-102X	MG RESISTOR	1.0K 5X 1/10W	
C 661	NCB21EK-104X	C CAPACITOR	1.0MF 10X 25V		R 261	NRSA02J-102X	MG RESISTOR	1.0K 5X 1/10W	
C 662	QER41AM-107	E CAPACITOR	100PF 5X 50V		R 262	NRSA02J-102X	MG RESISTOR	1.0K 5X 1/10W	
C 663	NCB21EK-104X	C CAPACITOR	1.0MF 10X 25V		R 263	NRSA02J-102X	MG RESISTOR	1.0K 5X 1/10W	
C 664	NCB21HK-223X	C CAPACITOR	0.22MF 10X 50V		R 264	NRSA02J-102X	MG RESISTOR	1.0K 5X 1/10W	
C 666	NCS21HJ-471X	C CAPACITOR	470PF 5X 50V		R 265	NRSA02J-223X	MG RESISTOR	22K 5X 1/10W	
C 667	NCF21CZ-105X	C CAPACITOR	1.0MF +80:-20X		R 266	NRSA02J-102X	MG RESISTOR	1.0K 5X 1/10W	
C 668	NCB21HK-473X	C CAPACITOR	0.47MF 10X 50V		R 267	NRSA02J-102X	MG RESISTOR	1.0K 5X 1/10W	
C 671	NCB21EK-104X	C CAPACITOR	1.0MF 10X 25V		R 268	NRSA02J-102X	MG RESISTOR	1.0K 5X 1/10W	
C 672	QER41AM-107	E CAPACITOR	100PF 5X 50V		R 269	NRSA02J-102X	MG RESISTOR	1.0K 5X 1/10W	
C 801	NCB21HK-852X	C CAPACITOR	8200PF 10X 50V		R 274	NRSA02J-102X	MG RESISTOR	1.0K 5X 1/10W	
C 802	NCB21HK-152X	C CAPACITOR	1500PF 10X 50V		R 275	NRSA02J-102X	MG RESISTOR	1.0K 5X 1/10W	
C 811	NCS21HJ-221X	C CAPACITOR	220PF 5X 50V		R 276	NRSA02J-102X	MG RESISTOR	1.0K 5X 1/10W	
C 812	NCS21HJ-221X	C CAPACITOR	220PF 5X 50V		R 277	NRSA02J-102X	MG RESISTOR	1.0K 5X 1/10W	
C 813	NCS21HJ-221X	C CAPACITOR	220PF 5X 50V		R 278	NRSA02J-102X	MG RESISTOR	1.0K 5X 1/10W	
C 814	NCS21HJ-221X	C CAPACITOR	220PF 5X 50V		R 279	NRSA02J-102X	MG RESISTOR	1.0K 5X 1/10W	
C 821	NCF21CZ-105X	C CAPACITOR	1.0MF +80:-20X		R 281	NRSA02J-102X	MG RESISTOR	1.0K 5X 1/10W	
C 822	QER41AM-247	E CAPACITOR	220MF 20X 10V		R 282	NRSA02J-102X	MG RESISTOR	1.0K 5X 1/10W	
					R 283	NRSA02J-102X	MG RESISTOR	1.0K 5X 1/10W	

REF.	PARTS NO.	PARTS NAME	REMARKS	SUFFIX
R 105	NRSA02J-220X	MG RESISTOR	22 5K 1/10W	
R 106	NRSA02J-392X	MG RESISTOR	3.9K 5X 1/10W	
R 107	NRSA02J-122X	MG RESISTOR	12K 5X 1/10W	
R 108	NRSA02J-222X	MG RESISTOR	2.2K 5X 1/10W	
R 109	NRSA02J-152X	MG RESISTOR	1.5K 5X 1/10W	
R 111	NRSA02J-562X	MG RESISTOR	5.6K 5X 1/10W	
R 112	NRSA02J-122X	MG RESISTOR	1.2K 5X 1/10W	
R 113	NRSA02J-271X	MG RESISTOR	270 5X 1/10W	
R 114	NRSA02J-391X	MG RESISTOR	390 5X 1/10W	
R 115	NRSA02J-332X	MG RESISTOR	3.3K 5X 1/10W	
R 117	NRSA02J-332X	MG RESISTOR	3.3K 5X 1/10W	
R 118	NRSA02J-152X	MG RESISTOR	1.5K 5X 1/10W	
R 119	NRSA02J-202X	MG RESISTOR	20K 5X 1/10W	
R 120	NRSA02J-102X	MG RESISTOR	1.0K 5X 1/10W	
R 121	NRSA02J-122X	MG RESISTOR	1.2K 5X 1/10W	
R 202	NRSA02J-102X	MG RESISTOR	1.0K 5X 1/10W	
R 203	NRSA02J-182X	MG RESISTOR	18K 5X 1/10W	
R 205	NRSA02J-220X	MG RESISTOR	22 5X 1/10W	
R 206	NRSA02J-392X	MG RESISTOR	3.9K 5X 1/10W	
R 207	NRSA02J-122X	MG RESISTOR	12K 5X 1/10W	
R 208	NRSA02J-222X	MG RESISTOR	2.2K 5X 1/10W	
R 209	NRSA02J-152X	MG RESISTOR	1.5K 5X 1/10W	
R 211	NRSA02J-562X	MG RESISTOR	5.6K 5X 1/10W	
R 212	NRSA02J-122X	MG RESISTOR	1.2K 5X 1/10W	
R 213	NRSA02J-272X	MG RESISTOR	270 5X 1/10W	
R 214	NRSA02J-391X	MG RESISTOR	390 5X 1/10W	
R 215	NRSA02J-332X	MG RESISTOR	3.3K 5X 1/10W	
R 217	NRSA02J-332X	MG RESISTOR	3.3K 5X 1/10W	
R 218	NRSA02J-152X	MG RESISTOR	1.5K 5X 1/10W	
R 219	NRSA02J-202X	MG RESISTOR	20K 5X 1/10W	
R 220	NRSA02J-102X	MG RESISTOR	1.0K 5X 1/10W	
R 221	NRSA02J-122X	MG RESISTOR	1.2K 5X 1/10W	
R 301	NRS181J-221X	MG RESISTOR	220 5X 1/8W	
R 302	NRS181J-101X	MG RESISTOR	100 5X 1/8W	
R 304	NRSA02J-391X	MG RESISTOR	39K 5X 1/10W	
R 305	NRSA02J-102X	MG RESISTOR	10K 5X 1/10W	
R 306	NRSA02J-102X	MG RESISTOR	10K 5X 1/10W	
R 307	NRSA02J-102X	MG RESISTOR	10K 5X 1/10W	
R 308	NRSA02J-152X	MG RESISTOR	1.5K 5X 1/10W	
R 309	NRSA02J-152X	MG RESISTOR	1.5K 5X 1/10W	
R 310	NRS181J-820X	MG RESISTOR	82 5X 1/8W	
R 311	NRS181J-820X	MG RESISTOR	82 5X 1/8W	
R 313	NRSA02J-3R2X	MG RESISTOR	3.3 5X 1/10W	
R 314	NRSA02J-222X	MG RESISTOR	22K 5X 1/10W	
R 315	NRSA02J-100X	MG RESISTOR	10 5X 1/10W	
R 316	NRSA02J-222X	MG RESISTOR	22K 5X 1/10W	
R 317	NRSA02J-100X	MG RESISTOR	10 5X 1/10W	
R 318	NRSA02J-122X	MG RESISTOR	12K 5X 1/10W	
R 319	NRSA02J-152X	MG RESISTOR	1.5K 5X 1/10W	
R 321	NRSA02J-122X	MG RESISTOR	12K 5X 1/10W	
R 322	NRSA02J-152X	MG RESISTOR	1.5K 5X 1/10W	
R 323	NRSA02J-474X	MG RESISTOR	470K 5X 1/10W	
R 328	NRSA02J-222X	MG RESISTOR	2.2K 5X 1/10W	
R 329	NRSA02J-222X	MG RESISTOR	2.2K 5X 1/10W	
R 330	NRSA02J-OR0X	MG RESISTOR	5X 1/10W	

REF.	PARTS NO.	PARTS NAME	REMARKS	SUFFIX
C 328	NCS21HJ-151X	C CAPACITOR	150PF 5X 50V	
C 329	NCS21HJ-151X	C CAPACITOR	150PF 5X 50V	
C 330	NCS21HJ-151X	C CAPACITOR	150PF 5X 50V	
C 332	NCS21HJ-151X	C CAPACITOR	150PF 5X 50V	
C 333	NCS21HJ-151X	C CAPACITOR	150PF 5X 50V	
C 335	NCS21HJ-103X	C CAPACITOR	0.10MF 10X 50V	
C 336	NCS21HJ-103X	C CAPACITOR	0.10MF 10X 50V	
C 337	NCS21HJ-103X	C CAPACITOR	0.10MF 10X 50V	
C 338	NCS21HJ-103X	C CAPACITOR	0.10MF 10X 50V	
C 339	QSK41CM-474	E CAPACITOR	47MF 20X 16V	
C 340	NCS21HJ-103X	C CAPACITOR	0.10MF 10X 50V	
C 341	QKJ1H-1072	E CAPACITOR	109MF 20X 10V	
C 342	QK41EM-475	E CAPACITOR	4.7MF 20X 25V	
C 343	QK141CM-106	E CAPACITOR	10MF 20X 16V	
C 344	NCS21HJ-472X	C CAPACITOR	4700PF 10X 50V	
C 345	NCS21HJ-331X	C CAPACITOR	330PF 5X 50V	
CN301	GGF1205F1-06	CONNECTOR		
CN302	GGF1205F1-06	CONNECTOR		
CN303	QGB2011M1-10	PWB CONNECTOR		
CN304	QGB2011M1-10	PWB CONNECTOR		
CN305	GGF1205F1-10	CONNECTOR		
CN306	GGF1205F1-11	CONNECTOR		
D 307	H7M5-1NB2-X	CHIP Z DIODE		
D 308	H7M5-1NB2-X	CHIP Z DIODE		
D 309	M47044-X	S-K-DIODE		
IC301	BA3124N	IC		
IC302	AM7362X	IC		
IC303	AM7362X	IC		
IC304	BU4094BCF-X	IC		
IC305	BU4094BCF-X	IC		
L 501	GR0650-001	OSC COIL (BIAS)		
L 503	QSL01BK-100Z	INDUCTOR		
Q 102	DFC144TKA-X	TRANSISTOR		
Q 103	DFC144TKA-X	TRANSISTOR		
Q 105	2SC3576-JVC-T	TRANSISTOR		
Q 202	DFC144TKA-X	TRANSISTOR		
Q 203	DFC144TKA-X	TRANSISTOR		
Q 205	2SC3576-JVC-T	TRANSISTOR		
Q 302	2SC2001/K-T	TRANSISTOR		
Q 303	2SC2001/K-T	TRANSISTOR		
Q 304	2SC3576-JVC-T	TRANSISTOR		
Q 305	2SC3576-JVC-T	TRANSISTOR		
Q 306	2SC2412K/RS/-X	CHIP TRANSISTOR		
Q 307	2SC2412K/RS/-X	CHIP TRANSISTOR		
Q 308	2SC2412K/RS/-X	CHIP TRANSISTOR		
Q 309	2SC2412K/RS/-X	CHIP TRANSISTOR		
Q 312	2SB562/C-T	TRANSISTOR		
Q 313	2SC2412K/RS/-X	CHIP TRANSISTOR		
Q 314	2SB562/C-T	TRANSISTOR		
Q 315	2SC2412K/RS/-X	CHIP TRANSISTOR		
Q 316	2SA952/LK/-T	TRANSISTOR		
Q 317	DFC124EKA-X	TRANSISTOR		
Q 321	DFC144EKA-X	TRANSISTOR		
Q 322	DFC144EKA-X	TRANSISTOR		
Q 323	2SC2412K/RS/-X	CHIP TRANSISTOR		
R 102	NRSA02J-102X	MG RESISTOR	1.0K 5X 1/10W	
R 103	NRSA02J-182X	MG RESISTOR	18K 5X 1/10W	

Electrical Parts List (Cassette Mechanism Switch Board)

BLOCK NO. 08		BLOCK NO. 07		
REF.	PARTS NO.	PARTS NAME	REMARKS	SUFFIX
R 335	MRS02J-222X	MG RESISTOR	2.2K 5X 1/10W	
R 336	MRS02J-322X	MG RESISTOR	3.9K 5X 1/10W	
R 337	MRS02J-222X	MG RESISTOR	2.2K 5X 1/10W	
R 338	MRS02J-222X	MG RESISTOR	2.2K 5X 1/10W	
R 339	MRS02J-222X	MG RESISTOR	2.2K 5X 1/10W	
R 340	MRS02J-222X	MG RESISTOR	2.2K 5X 1/10W	
R 341	MRS02J-222X	MG RESISTOR	2.2K 5X 1/10W	
R 342	MRS02J-222X	MG RESISTOR	2.2K 5X 1/10W	
R 343	MRS02J-222X	MG RESISTOR	2.2K 5X 1/10W	
R 344	MRS02J-222X	MG RESISTOR	2.2K 5X 1/10W	
R 345	MRS02J-222X	MG RESISTOR	2.2K 5X 1/10W	
R 346	MRS02J-222X	MG RESISTOR	2.2K 5X 1/10W	
R 347	MRS02J-222X	MG RESISTOR	2.2K 5X 1/10W	
R 348	MRS02J-222X	MG RESISTOR	2.2K 5X 1/10W	
R 349	MRS02J-222X	MG RESISTOR	2.2K 5X 1/10W	
R 350	MRS02J-472X	MG RESISTOR	4.7K 5X 1/10W	
R 351	MRS02J-151X	MG RESISTOR	150 5X 1/10W	
R 352	MRS02J-472X	MG RESISTOR	4.7K 5X 1/10W	
R 353	MRS02J-151X	MG RESISTOR	150 5X 1/10W	
R 354	MRS02J-151X	MG RESISTOR	150 5X 1/10W	
R 355	MRS02J-332X	MG RESISTOR	3.3K 5X 1/10W	
R 356	MRS02J-103X	MG RESISTOR	10K 5X 1/10W	
R 357	MRS02J-222X	MG RESISTOR	2.2K 5X 1/10W	
R 358	MRS02J-153X	MG RESISTOR	12K 5X 1/10W	
R 359	MRS02J-153X	MG RESISTOR	12K 5X 1/10W	
R 360	MRS02J-433X	MG RESISTOR	43K 5X 1/10W	
R 361	MRS02J-153X	MG RESISTOR	15K 5X 1/10W	
R 362	MRS02J-153X	MG RESISTOR	15K 5X 1/10W	
R 363	MRS02J-153X	MG RESISTOR	15K 5X 1/10W	
R 364	MRS02J-433X	MG RESISTOR	43K 5X 1/10W	
R 365	MRS02J-203X	MG RESISTOR	20K 5X 1/10W	
R 366	MRS02J-183X	MG RESISTOR	18K 5X 1/10W	
R 367	MRS02J-102X	MG RESISTOR	1.0K 5X 1/10W	
R 368	MRS02J-391X	MG RESISTOR	390 5X 1/10W	
R 369	MRS02J-391X	MG RESISTOR	390 5X 1/10W	
R 370	MRS181J-222X	MG RESISTOR	2.2K 5X 1/8W	
R 371	MRS181J-222X	MG RESISTOR	2.2K 5X 1/8W	
R 372	MRS02J-912X	MG RESISTOR	9.1K 5X 1/10W	
R 373	MRS02J-683X	MG RESISTOR	68K 5X 1/10W	
R 374	MRS181J-683X	MG RESISTOR	6.8K 5X 1/8W	
R 375	MRS181J-683X	MG RESISTOR	6.8K 5X 1/8W	
VR101	GVPO008-503Z	SEMI V RESISTOR		
VR501	GVPO008-503Z	SEMI V RESISTOR		
VR501	GVPO008-103Z	SEMI V RESISTOR		
WIRE	VWS304-10A13K	FLAT WIRE		

■ Electrical Parts List (Cassette Mechanism Switch Board)

				BLOCK NO. 09		
A	REF.	PARTS NO.	PARTS NAME	REMARKS	SUFFIX	
	CN	1	GGP20111-10	TOP PLUG ASSY		
	D	1	1SR139-100-T2	SI DIODE		
	IC	1	SG-105F3-BB/C	PHOTO SENSER		
	P	1	QNZ0104-001	POST PIN		
	SW	1	QSW0832-001	CASSETTE SWITCH R-REC		
	SW	2	QSW0833-001	CASSETTE SWITCH TAPE		
	SW	4	QSW0832-001	CASSETTE SWITCH 70U		
	SW	5	QSW0832-001	CASSETTE SWITCH F-REC		
	SW	6	QSW0507-001	SWITCH		

Packing Materials and Accessories Parts List

Block No.

M	5	M	M
---	---	---	---

Block No.

M	6	M	M
---	---	---	---

(MX-J55R)

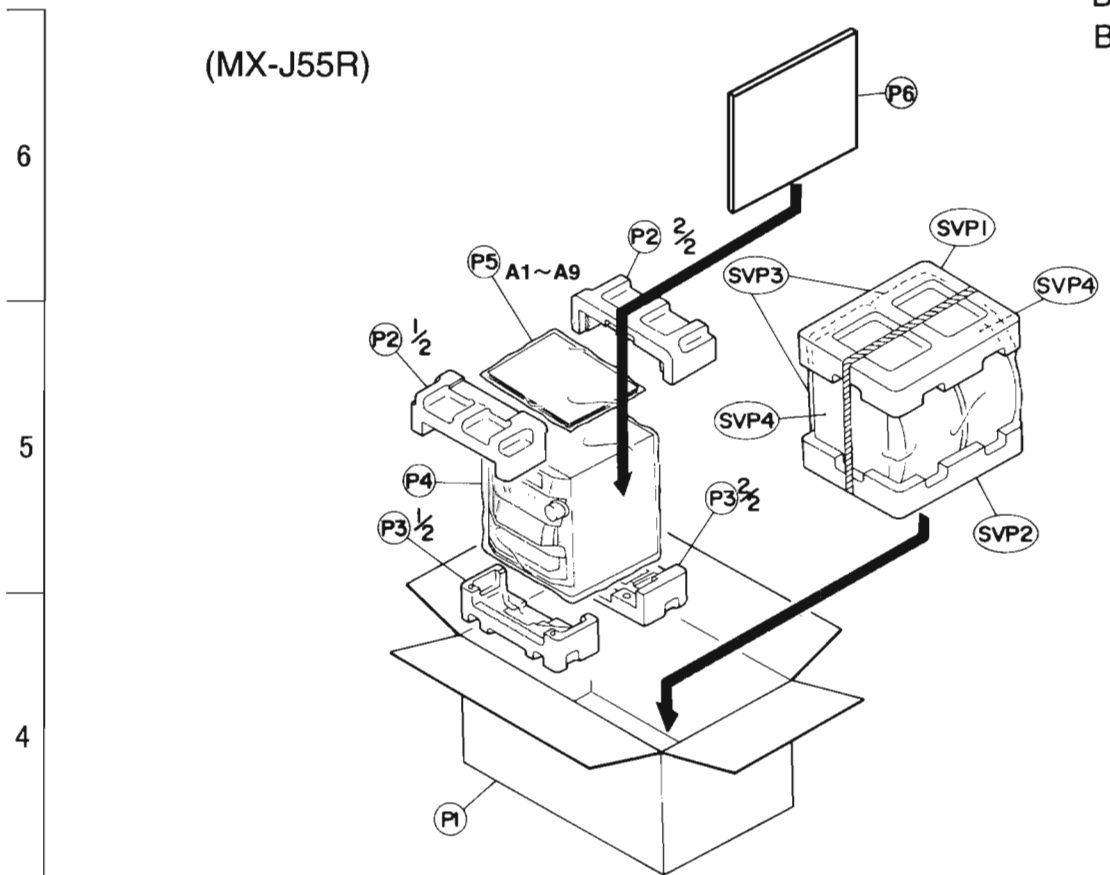

(CA-MXJ55R/MXJ530R)

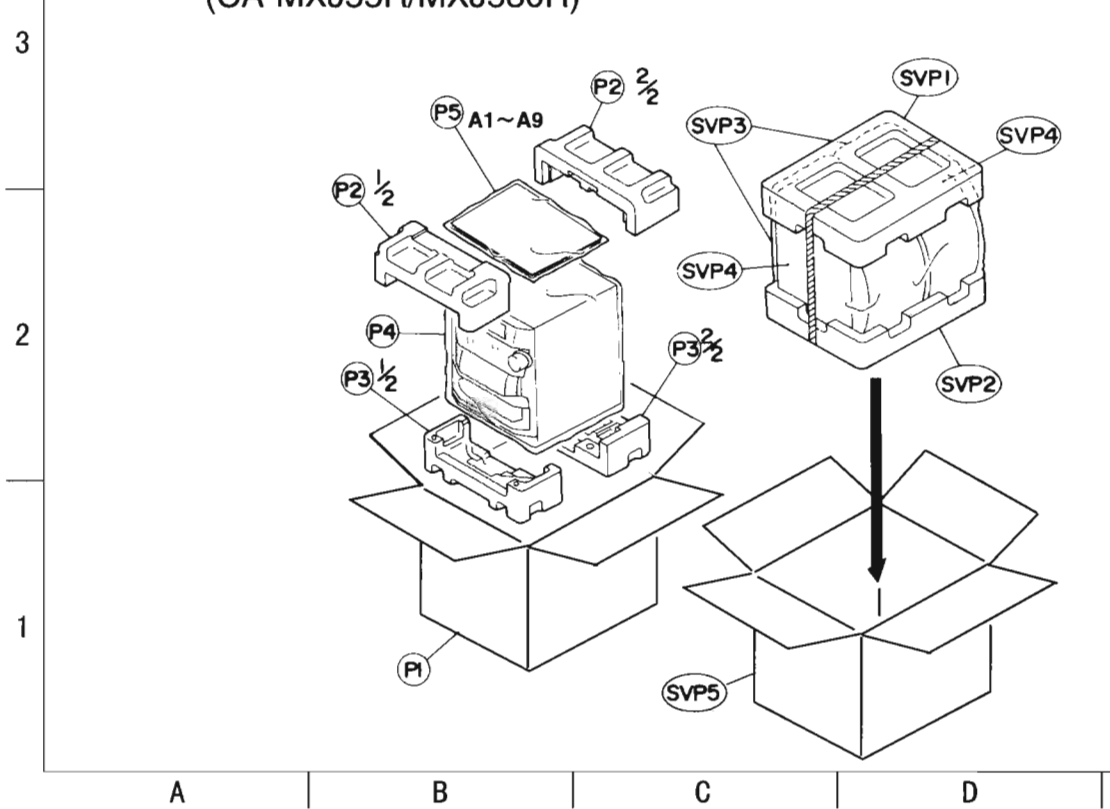

■ Packing Parts List

Block No.M5MM

△	Item	Parts Number	Parts Name	Q'ty	Description	Area
	P1	GV20036-013A	PACKING CASE	1	MX-J55R	
		GV20041-005A	PACKING CASE	1	CA-MXJ55R	
		GV20041-006A	PACKING CASE	1	CA-MXJ530R	
	P2	GV10016-003A	UPPER CUSHION	1	MX-J55R	
		GV10018-002A	UPPER CUSHION	1	CA-MXJ55R/MXJ530R	
	P3	GV10017-002A	BOTTOM CUSHION	1	MX-J55R	
		GV10019-002A	BOTTOM CUSHION	1	CA-MXJ55R/MXJ530R	
	P4	QPC06506515P	POLY BAG	1		
	P5	QPC02503515P	POLY BAG	1		
	P6	GV40047-001A	CORRUGATED	1	MX-J55R	
	SVP 1	720-TSPJ55-00	SPEAKER CUSHION(UPPER)	1	MX-J55R/CA-MXJ55R	
		720-TMXJ70-00	SPEAKER CUSHION(UPPER)	1	CA-MXJ530R	
	SVP 2	720-BSPJ55-00	SPEAKER CUSHION(BOTTOM)	1	MX-J55R/CA-MXJ55R	
		720-BMXJ70-00	SPEAKER CUSHION(BOTTOM)	1	CA-MXJ530R	
	SVP 3	700-120034-20	POLY BAG	2		
	SVP 5	GV20036-010A	SPEAKER PACKING CASE	1	CA-MXJ55R	
		GV20036-011A	SPEAKER PACKING CASE	1	CA-MXJ530R	

■ Accessories Parts List

Block No.M6MM

△	Item	Parts Number	Parts Name	Q'ty	Description	Area
	A1	GVT0012-006A	INSTRUCTION BOOK	1	CA-MXJ55R/MXJ530R	E
		GVT0012-007A	INSTRUCTION BOOK	1	CA-MXJ55R/MXJ530R	EN
		GVT0012-008A	INSTRUCTION BOOK	1	CA-MXJ55R/MXJ530R	B
		GVT0012-009A	INSTRUCTION BOOK	1	CA-MXJ55R/MXJ530R	EV
		GVT0012-010A	INSTRUCTION BOOK	1	MX-J55R	EE
	A2	EWP503-001	ANTENNA WIRE	1		
	A3	BT-54008-2	WARRANTY CARD	1		B,E,EN
	A4	E43486-340A	SAFETY SHEET	1		B
	A5	VNA3000-202	REGISTER CARD	1		B
	A6	BT-54012-1	W.CARD	1		EE,EV
	A7	RM-SMXJ55R	WIRE-LESS REMOTE CONTROL	1		
	A8	-----	BATTERY	1		
	A9	QAL0014-001	LOOP ANTENNA	1		
	SVP 4	MXJ50K-SPBOX-L	SPEAKER BOX(L)	1	MX-J55R/CA-MXJ55R	
		MXJ50K-SPBOX-R	SPEAKER BOX(R)	1	MX-J55R/CA-MXJ55R	
		MXJ56K-SPBOX-L	SPEAKER BOX(L)	1	CA-MXJ530R	
		MXJ56K-SPBOX-R	SPEAKER BOX(R)	1	CA-MXJ530R	

CA-MXJ55R/CA-MXJ530R

JVC

VICTOR COMPANY OF JAPAN, LIMITED

AUDIO DIVISION, 10-1, 1Chome, Ohwatari-machi, maebashi-city, 371-8543, Japan