

JVC

SERVICE MANUAL

COMPACT COMPONENT SYSTEM

CA-S20BK

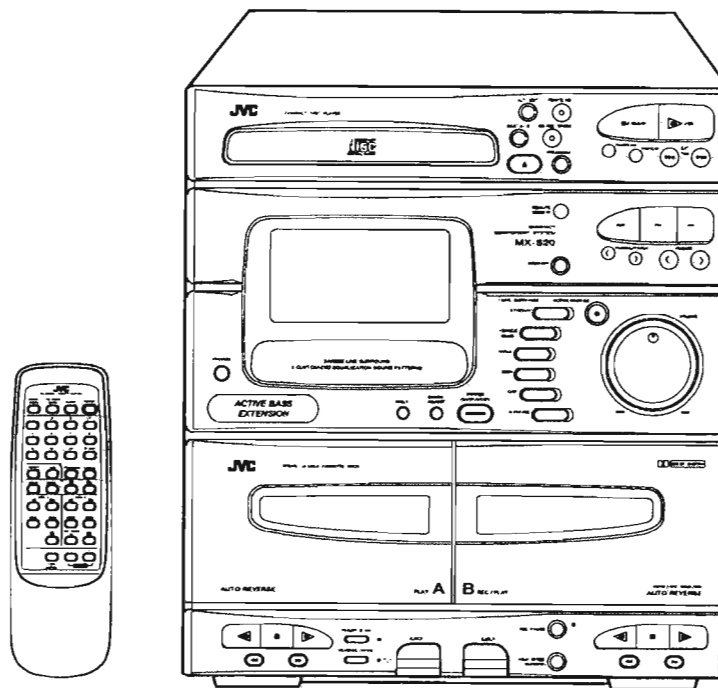

COMPACT
disc
DIGITAL AUDIO

Contents

<i>Safety Precautions</i>	1-2	<i>Maintenance of Laser Pickup</i>	1-41
<i>Important for Laser Products</i>	1-3	<i>Replacement of Laser Pickup</i>	1-41
<i>Instruction Book</i>	1-4	<i>Block Diagrams</i>	1-42
<i>Description of Major LSIs</i>	1-15	<i>Application Points for Grease</i>	1-47
<i>Internal Connection of FL Display Tube</i> ..	1-29	<i>Schematic Diagrams</i>	Insertion
<i>Disassembly Procedures</i>	1-30	<i>Printed Circuit Boards</i>	Insertion
<i>Adjustment Procedures</i>	1-36	<i>Parts List</i>	Insertion
<i>Flow of Functional Operation</i>			
<i>Until TOC is Read</i>	1-40		

Safety Precautions

1. The design of this product contains special hardware and many circuits and components specially for safety purposes. For continued protection, no changes should be made to the original design unless authorized in writing by the manufacturer. Replacement parts must be identical to those used in the original circuits. Services should be performed by qualified personnel only.
2. Alterations of the design or circuitry of the product should not be made. Any design alterations of the product should not be made. Any design alterations or additions will void the manufacturer's warranty and will further relieve the manufacture of responsibility for personal injury or property damage resulting therefrom.
3. Many electrical and mechanical parts in the products have special safety-related characteristics. These characteristics are often not evident from visual inspection nor can the protection afforded by them necessarily be obtained by using replacement components rated for higher voltage, wattage, etc. Replacement parts which have these special safety characteristics are identified in the Parts List of Service Manual. Electrical components having such features are identified by shading on the schematics and by (Δ) on the Parts List in the Service Manual. The use of a substitute replacement which does not have the same safety characteristics as the recommended replacement parts shown in the Parts List of Service Manual may create shock, fire, or other hazards.
4. The leads in the products are routed and dressed with ties, clamps, tubings, barriers and the like to be separated from live parts, high temperature parts, moving parts and/or sharp edges for the prevention of electric shock and fire hazard. When service is required, the original lead routing and dress should be observed, and it should be confirmed that they have been returned to normal, after re-assembling.
5. Leakage current check (Electrical shock hazard testing)
After re-assembling the product, always perform an isolation check on the exposed metal parts of the product (antenna terminals, knobs, metal cabinet, screw heads, headphone jack, control shafts, etc.) to be sure the product is safe to operate without danger of electrical shock.
Do not use a line isolation transformer during this check.

- Plug the AC line cord directly into the AC outlet. Using a "Leakage Current Tester", measure the leakage current from each exposed metal parts of the cabinet, particularly any exposed metal part having a return path to the chassis, to a known good earth ground. Any leakage current must not exceed 0.5mA AC (r.m.s.).

- Alternate check method
Plug the AC line cord directly into the AC outlet. Use an AC voltmeter having, 1,000 ohms per volt or more sensitivity in the following manner. Connect a 1,500 Ω 10 W resistor paralleled by a 0.15 μ F AC-type capacitor between an exposed metal part and a known good earth ground.

Measure the AC voltage across the resistor with the AC voltmeter.

Move the resistor connection to each exposed metal part, particularly any exposed metal part having a return path to the chassis, and measure the AC voltage across the resistor.

Now, reverse the plug in the AC outlet and repeat each measurement. Any voltage measured must not exceed 0.75 V AC (r.m.s.). This corresponds to 0.5 mA AC (r.m.s.).

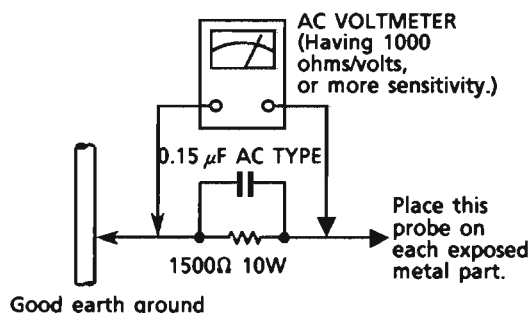

Warning

1. This equipment has been designed and manufactured to meet international safety standards.
2. It is the legal responsibility of the repairer to ensure that these safety standards are maintained.
3. Repairs must be made in accordance with the relevant safety standards.
4. It is essential that safety critical components are replaced by approved parts.
5. If mains voltage selector is provided, check setting for local voltage.

Important for Laser Products

1. **CLASS 1 LASER PRODUCT**
2. **DANGER** : Invisible laser radiation when open and interlock failed or defeated. Avoid direct exposure to beam.
3. **CAUTION** : There are no serviceable parts inside the Laser Unit. Do not disassemble the Laser Unit. Replace the complete Laser Unit if it malfunctions.
4. **CAUTION** : The compact disc player uses invisible laser radiation and is equipped with safety switches which prevent emission of radiation when the drawer is open and the safety interlocks have failed or are defeated. It is dangerous to defeat the safety switches.
5. **CAUTION** : If safety switches malfunction, the laser is able to function.
6. **CAUTION** : Use of controls, adjustments or performance of procedures other than those specified herein may result in hazardous radiation exposure.

VARNING : Osynlig laserstrålning när denna del är öppnad och spärren är urkopplad. Betrakta ej strålen.

VARO : Avattaessa ja suojalukitus ohitettaessa olet alttiina näkymättömälle lasersäteilylle. Älä katso säteeseen.

ADVARSEL : Usynlig laserstrålning ved åbning, når sikkerhedsafbrydere er ude af funktion. Undgå udsættelse for stråling.

ADVARSEL : Usynlig laserstrålning ved åbning, når sikkerhedsbryteren er avslott. unngå utsettelse for stråling.

REPRODUCTION AND POSITION OF LABELS

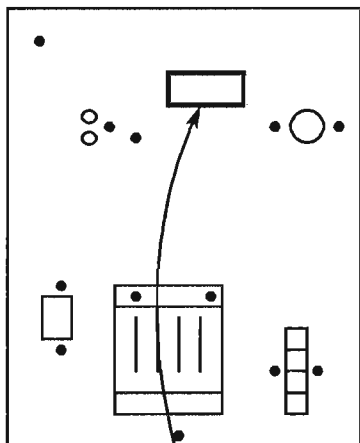

**CLASS 1
LASER PRODUCT**

CLASSIFICATION LABEL

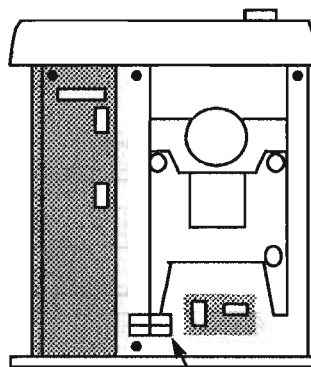

WARNING LABEL

DANGER: Invisible laser radiation when open and interlock failed or defeated. AVOID DIRECT EXPOSURE TO BEAM. (e)

VARNING: Osynlig laserstrålning när denna del är öppnad och spärren är urkopplad. Betrakta ej strålen. (s)

ADVARSEL: Usynlig laserstrålning ved åbning, når sikkerhedsafbrydere er ude af funktion. Undgå udsættelse for stråling. (d)

VARO: Avattaessa ja suojalukitus ohitettaessa olet alttiina näkymättömälle lasersäteilylle. Älä katso säteeseen. (f)

Control Panel and Remote — Illustrations

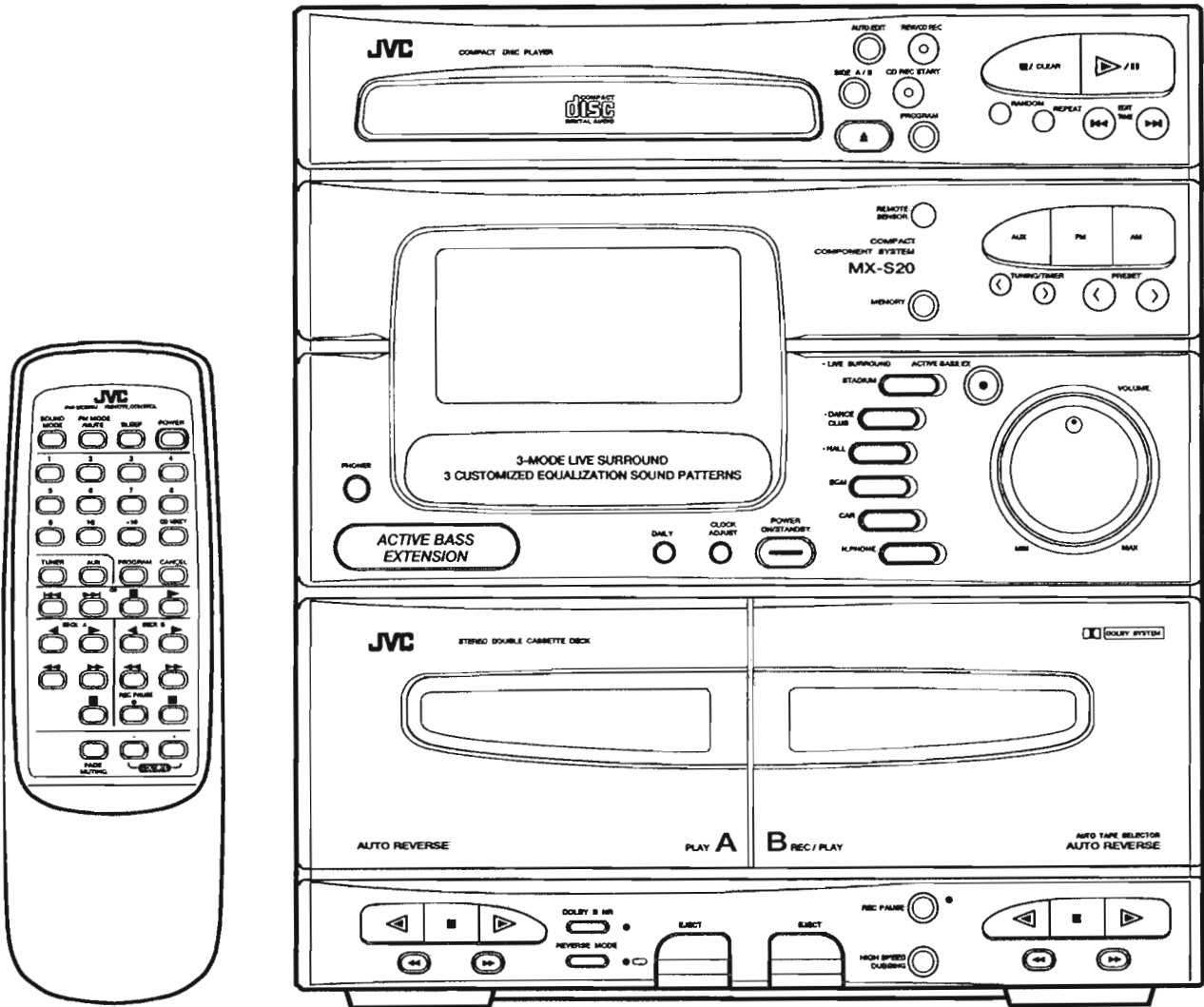

Troubleshooting

- If you are having a problem with your CA-S20BK, check this list for a possible solution before calling for service.
- If you cannot solve the problem from the hints given here, or the Unit has been physically damaged, call a qualified person, such as your dealer, for service.

Symptom	Possible Cause	ACTION
No sound is heard.	Connections are incorrect, or loose.	Check all connections and make corrections. (See pages 3 and 4.)
Impossible to record.	Cassette record protect tabs are removed.	Cover holes on back edge of cassette with tape.
Hard to listen to broadcasts because of noise.	The antenna is disconnected. The loop antenna is too close to the system. The feeder/wire antenna is not properly extended and positioned.	Re-connect the antenna securely. Change the position and direction of the loop antenna. Extend feeder/wire antenna at the best reception position.
The CD sound is discontinuous.	The CD is scratched or dirty.	Clean or replace the CD.
Unable to operate the Remote.	The path between the Remote and the sensor on the Unit is blocked. The batteries are discharged.	Remove the obstruction. Replace the batteries.
The CD tray cannot be operated.	The main AC power cord is not plugged in.	Plug in the AC power plug.
The CD does not play.	The CD is upside down.	Put the CD in with the label side up.
Operations are disabled.	The built in microprocessor may malfunction due to external electrical interference.	Unplug the system then plug it back in.
The cassette carrier cannot be opened.	The system was turned off because the timer was operated while the tape was running.	Turn On the system.

Specifications

Amplifier

25 watts per channel, min. RMS, both channels driven into 6 ohms, from 60 Hz to 20 kHz, with no more than 0.9% total harmonic distortion.

Input Sensitivity/Impedance (1 kHz)
AUX 300 mV/50 kohms

Speaker terminals
Main speakers 6 ohms

Tape deck

Frequency response
CrO₂: 30 ~ 16,000 Hz
Normal: 30 ~ 15,000 Hz

Wow and Flutter 0.09% (WRMS)

Tuner

FM Tuner

Tuning Range 87.5 ~ 108.0 MHz
Usable Sensitivity 0.95 μ V/75 ohms (10.8 dBf)
Signal-to-Noise Ratio MONO (at 85 dBf) 80 dB
(IHF-A weighted) STEREO (at 85 dBf) 73 dB

AM Tuner

MW- Tuning Range 530 ~ 1,710 kHz

Compact Disc Player

Dynamic Range (1 kHz) 90 dB
Signal-to-Noise Ratio 95 dB
Wow and Flutter Unmeasurable

General

Power Requirements AC 120 V ~ 60 Hz
Power Consumption 95 Watts
Dimensions (Approx.) 245 x 265 x 344.5 mm (W/H/D)
(9³/₄ x 10¹/₂ x 13⁹/₁₆ in.)
Weight (Approx.) 7.3 kg (16.1 lbs)

Supplied Accessories

FM feeder antenna (1)
AM loop antenna (1)
Remote control (RM-SES20U) (1)
Batteries R6P(SUM-3)/AA(15D, 15F) (2)
Antenna adaptor (1)

Design and specifications subject to change without notice.

Connection Diagrams and Instructions

Connecting the FM and AM Antennas

FM Antenna Connections

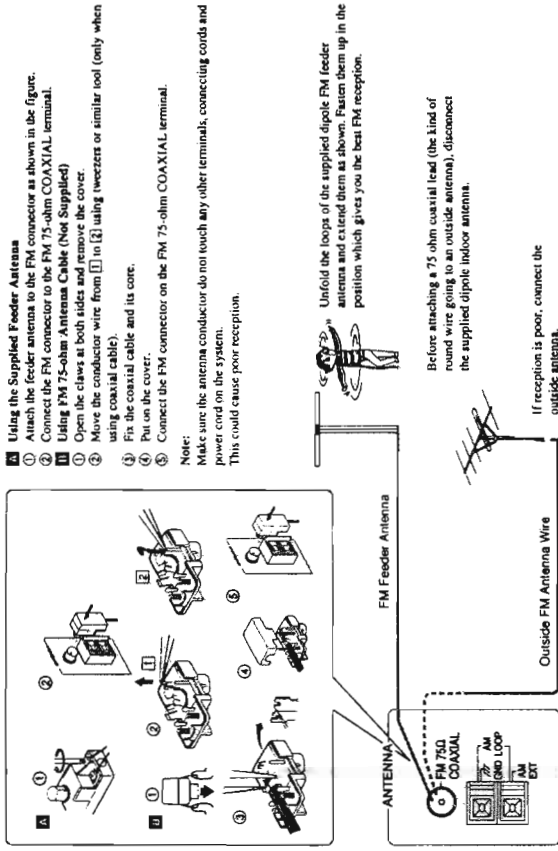

How to Strip the 75-ohm Coaxial Cable

1. Strip back the outside covering of the 75 ohm coaxial cable to expose the braided metallic mesh.
2. Pull the mesh back and twist into a single conductor as shown.
3. Strip the insulation about 10 mm back from the central wire.
4. Attach to the supplied Antenna Adaptor, as shown in the diagram above.

AM Antenna Connections

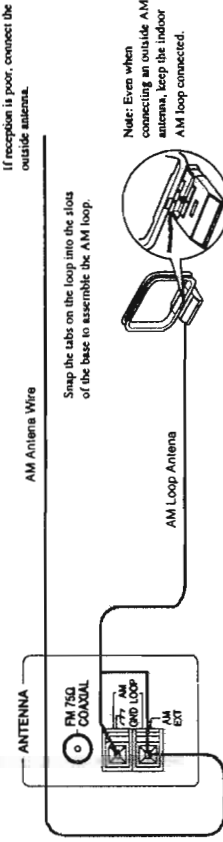

Features

Here are some of the things that make your CA-S20BK powerful and easy to use.

- Pre-programmed live surround effects like STADIUM, DANCE CLUB, HALL, as well as SEA effects like BGM, CAR, H, PHONE, so you don't have to be a sound engineer to get great effects.

Easy operation

- The controls and operations have been redesigned to make them very easy to use so you can spend your time listening to music.
- With the One Touch Operation feature of JVC's new COMPUPLAY you can turn on the CA-S20BK and start the radio, the tape deck, or the CD player with a single touch.
- Two timers, DAILY Timer and SLEEP Timer are extremely easy to set so you can really use them.
- The Display is large and clear. It's organized so you can tell at a glance what's happening because functions light up as you use them, and blink to tell you they are ready. It gives you some important messages like "NO DISC," "NO TAPE," and some others.
- Auto Edit figures out how to arrange CD tracks on a tape. When you are recording a tape from a CD, the selections aren't cut off if the tape ends before the selection does.



IMPORTANT CAUTIONS

1. **Installation of the Unit**
 - Select a place which is level, dry and neither too hot nor too cold (between 5°C and 35°C).
 - Leave sufficient distance between the Unit and your TV.
 - Do not use the Unit in a place subject to vibrations.
2. **Power cord**
 - Do not handle the power cord with wet hands!
 - When unplugging from the wall outlet, always pull the plug, not the power cord.
3. **Multifunctions, etc.**
 - There are no user serviceable parts inside. If anything goes wrong, unplug the power cord and consult your dealer.
 - Do not insert any metallic object into the Unit.

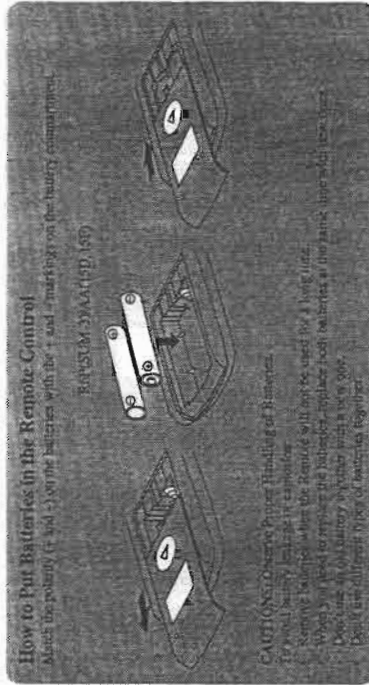

Connecting the Speakers

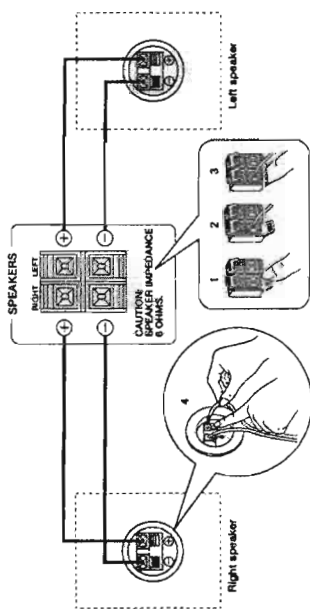

For each speaker, connect one end of the speaker wire to the speaker terminals on the back of the CA-S20BK, and one end to the speaker. On the back panel:

1. Open each terminal.
2. Insert the end of the speaker wire as shown (be sure to remove the insulation at the end of each wire first).
3. Close the terminals to clamp the speaker wires firmly in place.
4. Connect the red (+) and black (-) terminals of the right side speaker to the red (+) and black (-) terminals marked **RIGHT** on the CA-S20BK.
Connect the red (+) and black (-) terminals of the left side speaker to the red (+) and black (-) terminals marked **LEFT** on the CA-S20BK.

IMPORTANT: Match the polarity of the speaker terminals with the polarity of the terminals on the CA-S20BK, red (+) to red (+) and black (-) to black (-). Check your speakers for correct impedance: 6 ohms only.

Connecting Auxiliary Equipment

VCR



Read Me First

The Engineers at JVC have made the CA-S20BK very easy to use, and if you are experienced using audio equipment, you can figure out how to use some of the CA-S20BK controls by yourself. However, we have built some new features into this model, which you can learn about easily from the manual.

If you are a new user or just want a review, this manual explains how to use the CA-S20BK and take advantage of its features for playing and recording music, as well as other sounds. One way to use this manual is to read it through now and refer back to it when you need to refresh your skills for some special operation. Of course you can just look up the topics such as recording a CD, that you want to do, but remember that you may need to refer to other parts of the manual for some of the instructions; for instance, in explaining how to record a CD, we assume you already know how to load a CD. That's why we recommend that you read the manual through once before starting. We've made it short, and easy to follow.

However before you proceed, please read the Cautions on page 2 and the set-up directions.

How This Manual Is Organized

We have incorporated some special features in this manual:

- A G2 page to look at while you read the instructions showing the front controls of the CA-S20BK. Some procedures have the illustrations of which control to use right with them, and for some you will need to look at the look-out for the illustration.
- Basic information that is the same for many different functions is grouped in one place, and not repeated in each procedure. For instance, in the section on playing a CD, we do not repeat the information about setting the volume and the sound conditioning, which are mentioned in the Common Operations section.
- Names of buttons, controls and function names that light up on the display panel are written in all Capital letters like this: **POWER**.
- When we are talking about the function, rather than the **BUTTON** or **DISPLAY**, then we just capitalize the first letter of the words.
- The **!** alerts you to important information or how to solve special problems that may occur when using the CA-S20BK.

The column on the left of the page is a special place to make it easier to find just what you want to know about, with little headlines announcing what each part of the page is about. Sometimes illustrations and help(h) hints are placed here also.

- Information about what you can do (such as record a CD or preset a radio station) and how the Unit is designed to make doing this activity easy.
- Procedures, usually numbered in the order you do the steps, to guide you in exactly what to do to accomplish something, such as tune a radio station or record a tape.
- Information you need to know to make decisions about which functions of the CA-S20BK to use for particular tasks (such as when to use Dolby NR to improve tape sound) and special hints to make your work go smoothly, like reminding you to set the sound effects before starting the CD to tape recording, since they cannot be changed once recording begins without starting completely over.

The manual has a table of contents to help you easily look up what you want to know too. We've enjoyed making this manual for you, and hope you will use it to enjoy the sound and many features built into your CA-S20BK.

How to get the most for your money by using this manual.

IMPORTANT!
Special features for a special Manual.

Getting Started Right

Unpacking

Of course you have already opened your CA-S20BK carton, since you are reading this manual. Although the Unit is quite sturdy, you may want to save the packing to re-pack your CA-S20BK in case you are moving it some distance. Check to be sure you have all of the following things, which are supplied with the CA-S20BK:



AM Antenna

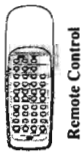

Remote Control



Antenna Adapter

FM Feeder Antenna

If any are missing, contact your dealer immediately.

Location

You can place the CA-S20BK in many different kinds of locations to suit your needs, just observe the cautions on page 2: keep away from moisture and heat; leave some space between the Unit and its surroundings, more than 1 cm at the sides of the console and 10 cm at the back.

Set Up

You will need to do the following four things to get your CA-S20BK ready to use.

1. Connect the Antenna(s).
2. Connect the Speakers.
3. Put Batteries (included) in the Remote.
4. Connect other sound sources (VCR) if used.

1. Connect the Antenna(s)

Follow the diagrams on page 3. Here's what you need to know:

- For AM reception you must connect the supplied loop antenna. If reception is poor, connect the outside antenna, but leave the loop antenna in place—the AM will not work correctly without it.
- For FM reception, connect the supplied wire as shown. However, if you use an outdoor antenna, disconnect the indoor FM antenna first.
- To avoid noise, keep antennas away from metallic parts of the CA-S20BK, connecting cords and the AC power cord.

2. Connect the Speakers

Basically, you look at the diagrams on page 4 and follow the pictured instructions.

3. Put Batteries in the Remote

Pay close attention to getting the batteries in correctly—we've made it very easy, just match the + and - marks on the batteries with the + and - markings on the Remote. See page 2 for instructions.

CAUTION: Handle batteries with care. See page 2 for proper use of batteries.

4. Connect Other Sound Sources, such as VCR

You can play the sound portion of a TV program or video tape through your CA-S20BK's sound system, often improving it greatly. A VCR can also be hooked up to play through the CA-S20BK. Just follow the diagram on page 4.

CAUTION: DO NOT connect optional equipment while the power is ON.

Now you can plug the AC power cord into the wall socket, and your CA-S20BK is at your command!

CAUTION: First make all connections before plugging the Unit into any AC power outlet.

Read on and find out how to use the many features built into your Unit.....

Common Operations

Here are the things that apply to all the functions of your CA-S20BK. If something in a procedure is unclear to you, check back here.

COMPUPLAY

COMPUPLAY is JVC's new feature that lets you control the most used functions of the CA-S20BK with a single touch. This One Touch Operation starts playing a CD, turns on the radio, plays a tape, etc. with a single press of the play button for that function. What One Touch Operation does for you is to turn the power on, then start the function you have called for. If the Unit is not ready, such as no CD or tape in place, the Unit still comes on and then gives you a message on the display so you can put in a CD or tape.

How One Touch Operation works in each case is explained in the respective section about that function.

Turning the CA-S20BK On

Press **POWER**: the **STANDBY** indicator on **POWER** goes out.

- The CA-S20BK comes on ready to do whatever it was doing when the power was last shut off. So if the last thing you were doing was listening to a tape in deck B, you now are ready to listen to a tape again in deck B, or you can change to another source.
- If you were listening to the radio last, the radio comes on playing that last station.

Turning the CA-S20BK Off

Press **POWER** again: the stand-by indicator lights up and the display blanks, except for the clock display.

- A small amount of power (1.3 watts) is always consumed even though the power is turned off (called standby mode).
- To switch the power off completely, unplug the power cord.

Controlling the Sound

The same set of buttons and knobs control the sound, no matter which function is producing it. Here we will briefly explain how these controls work, and how you can use them to increase your enjoyment of the music.

Volume Control

Rotate clockwise to increase loudness, counter-clockwise to reduce loudness. Be sure to read the caution at the end of this section about high sound levels damaging your hearing or your equipment.

Sound Modes

The CA-S20BK has some preset sound effects that let you control of way your music sounds, so you can tailor it for your room and for the quality of the source. We can give you some idea of how each one affects the music, but the only way to really tell is try them yourself.

You can use only one effect at a time selecting from the **LIVE SURROUND** and **SEA** effects. Feel free to experiment! To get an effect, press a preset button so that the "Effect" is shown on the display.

To cancel the effect, press the button again, or press another preset button to select another effect.

LIVE SURROUND effects

With these effects, the sound coming from only two speakers approaches the quality of sound from four speakers.

-STADIUM — Adds clarity and spreads the sound, like in an outdoor stadium.

-DANCE CLUB — Increase resonance and bass.

-HALL — Adds depth and brilliance to the sound, like in a concert hall.

Preset SEA (Sound Effect Amplifier) effects

Adjustments of frequency range levels have been preset as three SEA effects.

BGM — Used as a background music.

CAR — Used for recording tapes to listen to in a car.

H. PHONE — Used for recording tapes to listen to with headphones.

On the Remote, you can't find buttons for these preset sound effects. By pressing **SOUND MODE** on the Remote, you can cycle through the effects one after the other.

Things to remember about using preset effects:

- Set a preset effect before you start recording with **REW/CD REC** or **CD REC START**, because once recording starts, the preset effect cannot be changed without stopping recording, and often having to start over. If you need different effects for each selection, use the standard recording features described on page 13, rather than **REW/CD REC** or **CD REC START**.
- Each of the preset effects changes the sound in a different way by changing which parts of the sound are increased or reduced.

Active BASS Effect

The richness and fullness of the sound is maintained regardless of how high or low you set the VOLUME control. To get the effect, press ACTIVE BASS EX so that the indicator on the button lights up. To cancel the effect, press the button again so that the indicator goes off.

Listening with Headphones

A pair of headphones can be connected to the PHONUS jack on the front panel. Be sure to turn down the volume before connecting or putting on headphones, as high volume can damage both the headphones and your hearing.

The Display and the Indicators—Two Very Useful Hints

- The display tells you many useful things about what your Unit is doing. Watch it as you give instructions by pressing buttons. It also gives you some messages like "NO DISC", and some others to show you what to do next.
- Some of the controls have a small light, called an indicator, right next to or even right on the button or knob itself. The light comes on when the function is on, and goes off when it is not in use.

CAUTION: Always set the VOLUME control to MIN before turning on a connected source such as a VCR or starting any other of the sound sources such as the radio, tape, or CD player. Otherwise, if the VOLUME control is turned up, the sudden blast of sound energy can permanently damage your hearing and/or ruin your speakers.

The Display and the Indicators

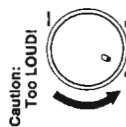

Listening to the Radio

You can listen to both AM and FM.
 ☐ Before listening to the radio, check that both the AM and FM antennas are firmly connected.

One Touch Radio

Just press AM to turn on the Unit and start playing the most recent AM station tuned in, or press FM to start the most recent FM station tuned in.
 ☐ You can switch from any other sound source to the radio by pressing either AM or FM.



Tuning in a Station

Press AM or FM to turn on the radio. The display shows the station frequency tuned to.

Three ways to tune in a station

1. Press TUNING/TIMER < or > repeatedly to move from frequency to frequency until you find the one you want.
 OR
2. Hold down TUNING/TIMER < or >, the frequency starts changing on the display. When a station is tuned in, "TUNED" lights up on the display and the frequency stops changing.
 OR
3. Press once and release PRESET < or > to go to the next preset station, or hold PRESET < or > to cycle through the preset stations; release the button when the preset station you want shows on the display. (This method is possible only after presetting stations.)

You can also use the Remote to tune in stations and preset channels:

1. Press FM or AM depending on which band you want.
2. Select the station by entering the preset channel number in the 10 key pad of the Remote.

Presetting Stations

Once a station is assigned to a channel number, the station can be quickly tuned either from the Remote using the 10 key pad of the Remote or the CA-S20BK itself using PRESET < or > to call up the channel number.

- You can preset 40 AM and FM stations at random.
- Preset stations may be erased when power is cut off to the Unit, as when it is unplugged from the AC outlet or a power failure occurs. If the preset stations are lost, simply set the stations again using the following procedure.

To preset radio stations

1. Tune in the station you want to set using TUNING/TIMER < or >.
2. Press MEMORY.
 On the display "MEMORY" will blink for 8 seconds.
 ☐ During these 8 seconds while "MEMORY" is blinking you can assign a channel number to the station and enter it into the memory.
3. Select a channel number by pressing PRESET < or > until you find the channel number you want.
4. Press MEMORY and the station will be assigned to the channel number showing on the display.
 ☐ If a station has been previously stored using the same channel number, it will be erased and the newly selected station will be stored.

How to preset AM and FM radio stations



Receiving in Stereo or Mono

When an FM stereo broadcast is hard to receive or noisy:

- Press FM MODE/MUTE on the remote control so that reception improves, although you loose the stereo effect. In this state, you will hear noise while tuning into stations.
- To restore stereo effect, press FM MODE/MUTE again so that "AUTO" appears on the display. In this state, when a program is broadcast in stereo, you will hear stereo sound; when in monaural, you will hear monaural sounds. Furthermore, in this state, you won't hear noise while tuning into stations.

Listening to a Compact Disc

The quickest way to start a CD is with the One Touch Operation:

- Press **D/II** on the CD player or **▶** on the Remote.
- If a CD is already loaded, the Unit automatically turns on and starts to play it from track 1.
- If no CD is loaded, the Unit automatically turns on and the CD tray opens. This is exactly the same as what happens if you press **▶** instead of **D/II**.

Basics of Using the CD Player

Here are the basic things you need to know to play a CD and locate the different selections on it. Each selection is called a track, so when we are talking about locating a track, we are also talking about how you find a certain song or performance.

To Play a CD

1. Press **▶**.
 2. Put a CD, printed side up, into the tray.
 3. If you want to listen to the CD now, press **D/II** (or **▶** on the Remote).
- The display shows the track being played and the length of time since it started.

To stop the CD, press **■/CLEAR** (or **■** on the Remote). When you start again, the CD begins with track 1.

To pause the play, press **D/II** while the CD is playing so when you press **D/II** again (or **▶** on the Remote) the CD starts where you left off.

To remove a CD, press **▶** take the CD out, and press **▶** again to close the tray. Keep the tray closed except during loading and unloading to protect the mechanism from dust and damage.

How to find a track

How to Find the Track or a Particular Point You Want

- Each time you press briefly and release **EDIT TIME** (or **▶** on the Remote) the track changes by one.
- Press and release **EDIT TIME** (or **▶** on the Remote) to go ahead one track at a time.
 - Press and release **EDIT TIME** (or **▶** on the Remote) to go back one track at a time.
 - Holding down **EDIT TIME** (or **▶**) will fast forward or fast reverse the CD so you can quickly find the particular part of a track you want to listen to. Fast forward and fast reverse are only possible by using the buttons on the Unit when the CD is playing.
 - Holding down **▶** or **▶** on the Remote allows you to change the tracks continuously. (By using the buttons on the Unit, it is only possible when the CD is not playing.)

Using the Remote to find a track

Locating a Track with the Remote

- Using the 10 key pad on the Remote allows you to go directly to the beginning of any track.
1. Press **▶**.
 2. Enter the number of the track you want using the 10 key pad. The selected track will start to play.
 - Example: for track 5, press 5. For track 15, press +10 then 5. For track 20, press +10, then 10.

With programming, you can play back tracks in any order

Programming the Playing Order of the Tracks

In addition to the high-quality sound which makes the CD such a good way to listen to music, you can change the order in which the tracks play.

Random Play

- The tracks will play in no special order when you use this play mode.
- Before starting a CD, press **RANDOM** on the CD player.
- When all of the tracks have been played, the CD shuts off.
- Press **REPEAT** before or during random play to instruct the CA-S20BK to continue with a different random track selection after the last selection is played.
- To cancel random play,** press **■/CLEAR** (or **■** on the Remote).

Program with the Remote

You can arrange the tracks to play in any order you like with the Program function. The Remote is very useful for this because you can select tracks by number with the 10 key pad. See "How to Use the Remote Control," page 18, if you need more information about its use. You can also use the main Unit.

How to program: just 3 easy steps



- To program the order of CD tracks using the Remote
1. Press **PROGRAM**.
 2. Press CD 10 key.
 3. Press the number of the first track you want to hear, then the number of the second track, and so on until you have entered all the track numbers you want to play.
 - Refer to the section "How to use the Remote Control" on page 18 if you have questions about how to enter numbers above 10.
 - Your program can include up to 32 tracks, and you can repeat tracks if you wish.
 4. Press **▶** to start the program—the first track you programmed will start to play, followed by the next one you entered, until all the selected tracks are played.

To program the CD from the Unit

1. Press **PROGRAM**.
2. Press **EDIT TIME** (or **▶**) to locate the track you want to start with.
3. Press **PROGRAM** to store the selected track.
4. Repeat steps 2 and 3 until you have entered all the tracks you want to program.
5. Press **D/II** and the Unit will begin playing the tracks in the order you programmed them.

To stop the CD during programmed play, press **■** on the Remote or **■/CLEAR** on the Unit while the CD is not playing.

Programming Hints

- A few hints to make programming easier
- To add a track to your program, enter the track numbers with the 10 key pad. Any tracks you add will appear at the end of the current program.
 - If you want to change the number of a track you just entered, press **CANCEL** on the Remote, and enter another number. (When the display shows the total program time, press **CANCEL** twice to remove the last selection entered.)
 - If you want to change the entire program, press **■/CLEAR** on the Unit while the CD is off, and then you can start over.
 - To check the order of the tracks in your program in **STOP** mode, press **▶** or **▶** on the Remote to display the order of the tracks. Each time you press **▶** the next selection in your program is displayed. (Press **▶** for the previous selections.)

Repeat a selection or the whole CD



You can have either the program or the individual selection currently playing repeat as many times as you like by pressing **REPEAT**.

Each time you press **REPEAT**, it cycles from function-off, which turns "REPEAT" out on the display, to "REPEAT" which will repeat all tracks in order or according to the program you have set, and then to "REPEAT" which will repeat the currently playing track.

To cancel repeat mode, press **REPEAT** until the "REPEAT" or "REPEAT 1" goes off on the display.

Listening to a Tape

- The tape deck allows you to play, record and dub audio tapes.
- Most of tapes are now recorded with the Dolby NR system, so first check which type of the Dolby NR system is used on the tape. Only the Dolby B NR is incorporated into the CA-S20BK.
 - With Automatic Tape Type Detection, you can listen to type I, II, or IV tapes without changing any settings.
 - To record or dub, see Recording on page 13.

COMPUTER PLAY

Playback Procedure

One Touch Play
By pressing either **D** or **▶** on either deck A or B (or **▶** on the Remote), the power will come on, and if a tape is in the deck, it will start to play. If no tape is loaded, the Unit will come on and wait for further instructions.

Regular Play

- When the power is already on, you can use this basic procedure:
1. Press **EJECT** of the deck you want to use.
 2. When the cassette carrier opens, put the cassette in, with the exposed part of the tape down (toward the base of the CA-S20BK).
 - If the cassette carrier does not open, turn the Unit off, then back on again and press **EJECT**.
 3. Close the carrier gently.
 4. Press **D** to play the front side, or **▶** to play the reverse side. The arrow indicator on the pressed button starts blinking and tape play starts.
- To stop playing,** press **■**.
- To remove the tape,** press **EJECT**.

Fast Left and Fast Right

- While the tape is stopped, press ◀ and the tape will wind rapidly onto the left side of the cassette without playing.
- While the tape is stopped, press ▶ and the tape will wind rapidly onto the right side of the cassette without playing.

Finding the piece you want: Music Scan

To find the beginning of a music track during play, use the Music Scan function. Music Scan searches for blank portions that usually separate tracks, then plays the next song.

- If you are recording on deck B or put deck B in recording pause mode, Music Scan will not work on deck A.

Scan Back

To find the beginning of the current song
Press ◀◀ or ▶▶ during play.
□ Make sure that you press ◀◀ or ▶▶ in the opposite direction as tape play. Searching stops automatically at the beginning of the current song, and the current song starts automatically.

Scan Forward

To find the beginning of the next song
Press ◀◀ or ▶▶ during play.
□ Make sure that you press ◀◀ or ▶▶ in the same direction as tape play. Searching stops automatically at the beginning of the next song, and the next song starts automatically.

er The Music Scan works by detecting a 4-second long blank at the beginning of each selection. So it won't work well if your tape has:

- No blank at the beginning of a track.
- Noise (often caused by much use or poor quality dubbing) which fills the blank with noise.
- Long very soft passages or pauses in a selection. The scan will detect these instead of the 4-second long blanks. If this happens, just go ahead and scan again until you reach the selection you want.

More Useful Things to Know:

- Reverse Mode
 - Continuous Play
 - Dolby
- Useful Other Features Using the Tape Deck**
- Use Reverse Mode to make the tape automatically reverse at the end of a side and start playing the other side. Press REVERSE MODE to change from Reverse Mode on (the indicator is lit) to Reverse Mode off, or from off, to on.
 - Continuous Play: When a tape finishes playing, the Unit always checks to see if a tape is in the other deck. If one is there, it automatically starts playing it while rewinding the first tape. This Continuous Play happens regardless of which deck starts first.
 - With the Reverse Mode on, the other tape will start playing when both sides of the first tape have been played. As long as the REVERSE MODE indicator is lit, the tapes will continue to play in the above sequence.
 - With the Reverse Mode off, the tape will play to the end of the current side, switch to the other deck and start playing a tape there while rewinding the first tape. Then when one side of the tape in the other deck is over, the first deck starts playing the same side again. The tapes will continue to play in the above sequence.
 - Press DOLBY B NR to switch Dolby Noise Reduction on (the indicator lights up) or off (the indicator goes off). If a tape is recorded with Dolby B NR, playing it back with the Dolby NR on will reduce tape noise and improve the clarity of the sound.

Dolby noise reduction manufactured under license from Dolby Laboratories Licensing Corporation. "DOLBY" and the double-D symbol are trademarks of Dolby Laboratories Licensing Corporation.

Listening to a VCR

Advantages in Connecting a VCR

1. Set the Unit's volume to MIN.
2. Press AUX on either the Remote or the Unit. "AUX" lights up on the display.
3. Start playing the connected equipment.
4. Adjust the volume level.

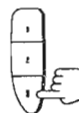

To cancel the AUX setting
Change the source by starting any one of the CA-S20BK's built in sound sources, such as the radio or CD player.

Recording

Recording onto cassette tape from any of the sound sources is easy and the CA-S20BK does most of the work. Just have a tape in deck B, have the source ready, make one or two settings, and you're ready to record.

For each source the procedure is a little different and now we'll explain just what to do for each one. If you forget, just go back to the section which has the specific procedures you need. But first, here are a few things to make your recordings better.

Things to Know before You Start Recording:

- Press DOLBY B NR — the indicator lights up — to reduce tape hiss, except when dubbing tapes since Dolby NR is inactive in dubbing mode regardless of the setting of DOLBY B NR. The dubbed tape automatically contains the same processing as the source tape.
- The recording level, which is the volume at which the new tape is being made, is automatically set correctly, so it is not affected by the VOLUME control on the CA-S20BK. Thus, you can adjust the sound you are actually listening to without changing the recording.
- Two small tabs on the back, one for side A and one for side B, can be removed to prevent accidental erasure or re-recording. To record on a cassette with the tabs removed, you must cover the holes with adhesive tape first. However, when a Type II tape is used, only cover part of the hole as shown, since the other part of the hole is used to detect the tape type.
- When recording, you can select the sound effects with the preset sound effect buttons to condition the music as it is recorded. But when recording using CD REC START or REW/CD REC, once recording has started, these settings cannot be changed. When recording from tape deck A to deck B, the sound effects cannot be used, because the signal doesn't go through the amplifier first. This method gives you the highest quality dubbed tapes.
- Type I and type II tapes can be used for recording. While type IV tapes can be played, type IV tapes cannot be used for recording on the CA-S20BK.



CAUTION: If recordings you make have excessive noise or static, the Unit may be too close to a TV which was on during the recording. Either turn off the TV or increase the distance between the TV and the CA-S20BK.

Standard Recording

This is the basic method for recording any source. The CA-S20BK also has special ways for recording CD to tape, and tape to tape, which save you time and effort, as well as give you some special effects. However, when you need to add a selection to a tape you have made, or are combining selections from several sources on one tape, use the method we describe here; just substitute the source you want, such as a tape in deck A, or CD, or radio in this procedure. You can also record from the microphone or an auxiliary source with this procedure.

To Record Any Sound Source to Tape

Follow these steps to record from any sound source onto a tape in deck B.

1. Insert a blank or erasable tape into deck B.
2. Press REC PAUSE.
3. Press REVERSE MODE if you want to record on both sides of the tape. The REVERSE MODE indicator lights up.
4. Prepare the source, for example, tuning in a radio station, loading a CD, turning on a connected VCR or turntable.
5. Press either ▷ to record on side A, or ◁ to record on side B of the tape, on deck B.

What can you record?

- Tapes
- Radio
- CDs
- Connected source

Reduce hiss—Dolby NR

Recording level

Erasure protection

Recording sound mode

Usable tape type

Standard recording: Any source to tape

Source to tape: Step by step

Fast Left and Fast Right

- While the tape is stopped, press ◀ and the tape will wind rapidly onto the left side of the cassette without playing.
- While the tape is stopped, press ▶ and the tape will wind rapidly onto the right side of the cassette without playing.

Finding the piece you want: Music Scan

To find the beginning of a music track during play, use the Music Scan function. Music Scan searches for blank portions that usually separate tracks, then plays the next song.

- If you are recording on deck B or put deck B in recording pause mode, Music Scan will not work on deck A.

Scan Back

To find the beginning of the current song
Press ◀◀ or ▶▶ during play.
□ Make sure that you press ◀◀ or ▶▶ in the opposite direction as tape play. Searching stops automatically at the beginning of the current song, and the current song starts automatically.

Scan Forward

To find the beginning of the next song
Press ◀◀ or ▶▶ during play.
□ Make sure that you press ◀◀ or ▶▶ in the same direction as tape play. Searching stops automatically at the beginning of the next song, and the next song starts automatically.

er The Music Scan works by detecting a 4-second long blank at the beginning of each selection. So it won't work well if your tape has:

- No blank at the beginning of a track.
- Noise (often caused by much use or poor quality dubbing) which fills the blank with noise.
- Long very soft passages or pauses in a selection. The scan will detect these instead of the 4-second long blanks. If this happens, just go ahead and scan again until you reach the selection you want.

More Useful Things to Know:

- Reverse Mode
 - Continuous Play
 - Dolby
- Useful Other Features Using the Tape Deck**
- Use Reverse Mode to make the tape automatically reverse at the end of a side and start playing the other side. Press REVERSE MODE to change from Reverse Mode on (the indicator is lit) to Reverse Mode off, or from off, to on.
 - Continuous Play: When a tape finishes playing, the Unit always checks to see if a tape is in the other deck. If one is there, it automatically starts playing it while rewinding the first tape. This Continuous Play happens regardless of which deck starts first.
 - With the Reverse Mode on, the other tape will start playing when both sides of the first tape have been played. As long as the REVERSE MODE indicator is lit, the tapes will continue to play in the above sequence.
 - With the Reverse Mode off, the tape will play to the end of the current side, switch to the other deck and start playing a tape there while rewinding the first tape. Then when one side of the tape in the other deck is over, the first deck starts playing the same side again. The tapes will continue to play in the above sequence.
 - Press DOLBY B NR to switch Dolby Noise Reduction on (the indicator lights up) or off (the indicator goes off). If a tape is recorded with Dolby B NR, playing it back with the Dolby NR on will reduce tape noise and improve the clarity of the sound.

Dolby noise reduction manufactured under license from Dolby Laboratories Licensing Corporation. "DOLBY" and the double-D symbol are trademarks of Dolby Laboratories Licensing Corporation.

Listening to a VCR

Advantages in Connecting a VCR

1. Set the Unit's volume to MIN.
2. Press AUX on either the Remote or the Unit. "AUX" lights up on the display.
3. Start playing the connected equipment.
4. Adjust the volume level.

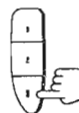

To cancel the AUX setting
Change the source by starting any one of the CA-S20BK's built in sound sources, such as the radio or CD player.

CD to tape recording: Introduction

CD to Tape Recording
There are three ways to record from CD to tape:
 Standard Recording, described on the previous page.
 CD Direct Recording — Everything on the CD goes onto the tape in the order it is on the CD, or according to an order you have set in a program.
 Auto Edit Recording — Your CA-S20BK figures out which selections to put on which side of the tape, so a selection isn't cut off before it's finished when the tape runs out.

REW/CD Recording Step by step

- REW/CD Recording**
1. Insert a blank or erasable cassette in deck B.
 If you want to record on both sides of the tape, press REVERSE MODE on the tape deck so that the REVERSE MODE indicator lights up.
 2. Load a CD into the tray and press **▲** to close the tray.
 3. Set the sound mode if you want, since the sound mode cannot be changed once recording starts.
 4. To record on the tape from its beginning, press REW/CD REC on the CD player.
 The Unit will automatically rewind the tape to the beginning of side A, create a 10 second blank, turn on the CD and start recording.
 To record on the tape from any portion of tape rather than its beginning, press CD REC START on the CD player.
 Without rewinding the tape and creating a 10 second blank, the Unit turns on the CD and starts recording.
 The CD REC START button is convenient for recording from many CDs.

At the end of the tape, the CA-S20BK automatically goes back to the beginning of the last selection and re-records it, this time gently fading out at the end. If you selected the Reverse Mode, side B starts with the last selection on side A. (A 10 second blank is also created on the beginning of side B.)
 When the tape is finished, the Unit shuts off the CD and the tape deck.

To stop any time during the recording process
 Press **■** on deck B.

In case of any operation during CD Recording, please use buttons on the Unit. (Don't press ones on the Remote Control.)

Auto Edit Recording: Introduction

Auto Edit Recording
Using Auto Edit, you can record the CD tracks to fit the tape, so a selection isn't cut off. Auto Edit is one of the best ways to copy all of a CD onto a tape.
 Auto Edit programs the CD tracks in the numerical order. To prevent the end of the last track on side A from being cut off, the last track on side A is selected to fit on the remaining tape length.

Auto Edit Recording: Step by step

1. Insert a blank or erasable cassette in deck B.
 If you want to record on both sides of the tape, press REVERSE MODE on the tape deck so that the REVERSE MODE indicator lights up.
2. Load a CD into the tray and press **▲** to close the tray.
3. Set the sound mode if you want, since the sound mode cannot be changed once recording starts.
4. Press AUTO EDIT on the CD player.
 "EDIT" appears on the display and then the minimum standard tape length to use for this CD appears.
 You can select a different length of tape, depending on the actual size of the tape you are using, from ten possibilities programmed into the CA-S20BK: 40, 46, 50, 54, 60, 64, 70, 74, 80, 84, 90. Cycle through these choices using EDIT TIME **◀** or **▶** (or **◀** or **▶** on the Remote) until you find the length closest to your tape's actual length.
 • If you pick a tape length shorter than the total playing time of the CD, the last tracks on both sides of the tape will be faded out as the tape ends.

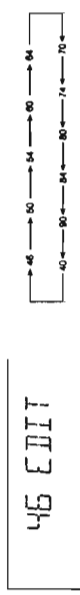

5. Press SIDE A/B.
 The display shows which tracks will go on side A and which on side B. Each time you press SIDE A/B, the display switches between A and B.
6. Press REW/CD REC on the CD player.
 The Unit will automatically rewind the tape to the beginning of side A, create a 10 second blank, turn on the CD and start recording. (A 10 second blank is also created on the beginning of side B.)

To stop any time during the recording process
 Press **■** on deck B.

Tape to tape dubbing: Introduction

Tape to Tape Recording (Dubbing)
Recording from one tape to another is called dubbing. You can dub at regular speed for the best possible quality, or with a slight loss in sound quality you can dub at high speed. With high speed it takes only about half the time to copy a tape.
 To dub both sides of a tape, start from side A for both deck A and deck B, and press REVERSE MODE so that the REVERSE MODE indicator lights up.
 It is preferable that the type of tape (Normal or CrO) you record from be the same as the type you record onto.

Regular speed dubbing: Step by step

- Regular Speed Dubbing**
1. Insert a source cassette you want to copy from into deck A for playback.
 2. Insert a blank or erasable cassette you want to copy onto into deck B for recording.
 3. Press REC PAUSE on deck B.
 4. Press **▷** (or **◀**) on deck B.
 Recording starts.
 To advance the leader tape, start recording first and wait about 10 seconds before starting the deck A.
 Press **▷** (or **◀**) on deck A.
 Deck A starts playing.
- To stop any time during the dubbing process
 Press **■** on both deck A and deck B.

High speed dubbing: Step by step

- High Speed Dubbing**
Although the quality of the dubbed tape is a little less, high speed dubbing is a very convenient way to record from one tape to another.
1. Insert a source cassette you want to copy from into deck A, and a blank or erasable cassette to be copied onto in deck B.
 2. For each deck, select the side (A or B) to start with.
 To change the side, press **◀** or **▷** and then quickly press **■** on the same deck.
 The tape will travel in the direction of the lit arrow indicator on the **◀** or **▷** button for each deck.
 3. Press HIGH SPEED DUBBING on the tape deck.
 Both decks start, deck A playing and deck B recording.
- To stop any time during the dubbing process
 Press **■** on deck B.



To record selections from several different tapes during high speed dubbing
 When you want to take selections from several different tapes and combine them on one tape during high speed dubbing, follow these steps:

1. Press **■** on deck A.
 This causes deck A to stop, so you can change tapes, and deck B makes a 4 second blank and pauses.
 • If you don't want to make a 4 second blank, press REC PAUSE before pressing **■** on deck A.
2. Change the tape in deck A.
3. Press HIGH SPEED DUBBING to start deck A playing and deck B recording again.
 This sound you hear is strange because it is much faster than usual, and you may not want to listen to it. Turn it down with the VOLUME control, or press PAUSE MUTE on the Remote.
 You can also listen to another source such as the radio or the CD player, just as if you weren't dubbing.

■ Dolby NR is inactive in dubbing mode regardless of the setting of DOLBY B NR. The dubbed tape automatically contains the same processing as the source tape.
■ You cannot dub using the sound modes such as STADIUM, DANCE CLUB, HALL, etc.
■ During high speed dubbing, if you listen to a CD with Auto Power Off turned on, the whole Unit, including the tape decks, may turn off when the CD ends. It will interrupt the dubbing.

How to Set the Clock and Use the Timers

Two Timers:
-DAILY
-SLEEP

The timers let you control recording and playing functions automatically. With the CA-S20BK they are particularly easy to set and use. Two types of timers are available:
 DAILY Timer—Wake up to music from any source.
 SLEEP Timer—Fall asleep and have your CA-S20BK turn off automatically after a certain length of time.

Clock Setting

The timers depend on the clock. If the clock is right, the timers will work like you expect, but if the time is incorrect on the clock then the timers will also be incorrect.

Notice: The clock must be set, or the timers cannot be set!

So, let's set the clock first:

1. Press **CLOCK ADJUST** button.
2. Set the hour by pressing the **TUNING/TIMER <** or **>** button. Press the **>** button increase the hour, and pressing the **<** button decreases it.
3. Press the **MEMORY** button.
4. Set the minutes by pressing **TUNING/TIMER <** or **>** button. Press the **>** button increase the minute, and pressing the **<** button decreases it.
5. Press the **MEMORY** button again and the clock is set and starts from zero second.

⚠ If there is a power failure, the clock loses its setting, the display shows "AM 12:00", and it must be reset.

IMPORTANT!
Set your clock!

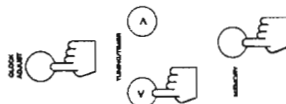

Wake up to music with the DAILY Timer



Setting the DAILY Timer

With this timer you can wake up to music from a CD, tape or your favourite radio program.
 You can set the DAILY Timer whether the Unit is on or off.

Follow this procedure to set the DAILY Timer

1. Press **DAILY** so that "DAILY TIMER" blinks on the display.
 Use the **TUNING/TIMER <** or **>** button just like setting the clock, then press **MEMORY**.
2. Set the time you want the Unit to turn on.
 Each time you press this button, the display shows one of the four possible sources: CD, TAPE, FM or AM. Leave the one you want lit.
 - If you select AM or FM as the source, the last played station is the one which comes on at the set time. The Unit will memorize the setting.
3. Select the sound source with the **TUNING/TIMER <** or **>** button.
 If you press any button while the DAILY Timer is being activated, the Unit will not turn off automatically after 60 minutes.
4. Press **DAILY** or **MEMORY** again, or wait eight seconds. "DAILY TIMER" lights up on the display.
 The Unit will memorize the setting.
 When the set time comes, the CA-S20BK turns on ("DAILY" appears on the display), plays the source you have selected for 60 minutes, and then the Unit turns off.
 If you press any button while the DAILY Timer is being activated, the Unit will not turn off automatically after 60 minutes.

Before turning off the Unit

- If the source is tape:
 - Check that the tape transport direction is correct. This is important especially when Reverse Mode is off.
 - Deck A has priority, so if tapes are in both decks, the tape in deck A plays first.
- Set Reverse Mode on if you want play both sides of the tape.
- Select the sound mode if you want to listen using a sound mode (STADIUM, DANCE CLUB, HALL, etc.).
- Set the volume to an appropriate level.

To change the DAILY Timer setting

Press **DAILY** twice ("DAILY" reappears) and make any changes you want.

To cancel the DAILY Timer setting

Press **DAILY** button again so that "DAILY TIMER" goes off on the display.

Sleep Timer: turns the Unit off automatically after a set time



Setting the SLEEP Timer

Use the SLEEP timer to turn the Unit off after a certain number of minutes when it is playing. Using this timer, you can fall asleep to music.
 You can only set the SLEEP Timer when the CA-S20BK is on and a source is playing.

Follow this procedure to set the SLEEP Timer

With the CA-S20BK on and a source playing, press **SLEEP** on the Remote Control. "SLEEP" starts blinking on the display.
 Each time you press **SLEEP** while "SLEEP" is blinking, it changes the number of minutes shown on the display in this sequence:

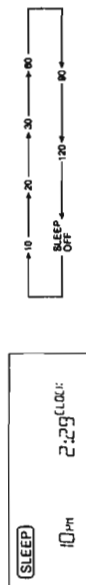

When the number of minutes you want shows on the display, just wait 8 seconds until "TIMER OK" appears and "SLEEP" stops blinking, but remains lit.
 The Unit will now turn off after the number of minutes you set.

To change the SLEEP Timer setting

Press **SLEEP** until the number of minutes you want appears on the display.

To cancel the SLEEP Timer setting

Press **SLEEP** until "SLEEP" goes off on the display.

Turning off the Unit also cancels the SLEEP Timer.

Timer Priority

The SLEEP Timer has priority over the DAILY Timer. This is important because if you set the SLEEP Timer to start before and then end after the DAILY Timer would start, the DAILY Timer doesn't come on. So if you want your alarm to go off as scheduled, be sure the SLEEP Timer shuts off before the DAILY Timer is to turn on the Unit.

How to Use the Remote Control

The Remote Control makes it easy to control many of the functions of the CA-S20BK from a distance of up to 6 m away. You need to point the remote sensor at the CA-S20BK from panel.

- Most of the buttons on the Remote Control do just what the ones on the CA-S20BK do.
- A few functions are available only by using the Remote Control, and those are described below.
- The buttons whose names or marks are printed in blue can be used for the One Touch Operation.

Using the 10 Key Pad

The 10 key pad is used to specify a CD track or the number you have assigned to a preset radio station. To enter a number using the 10 key pad follow these steps:

- Before using the 10 key pad, make sure which the 10 key pad functions for, the CD player or tuner.
- This is depends on which button on the Remote you have pressed before 10 key pad. For example, if you press AM or FM before 10 key pad, it can select a preset station. If you press ► for the CD player, it can select a CD track.
- For numbers between 1 and 10, just press the button with the number you want.
- For numbers from 11 to 20, first press the +10 key, then the one's digit of the number you want — to get 15, first press +10, then 5. For 20 press +10 and 10.
- For numbers from 21 to 30, press the +10 key twice, then press the one's digit — to get 25, press +10 +10 and 5. For 30, press +10 +10 and 10.
- For numbers from 31 to 40, follow the same procedure, only press the +10 key three times, then the one's digit — to get 32, press +10 +10 +10 and 2.

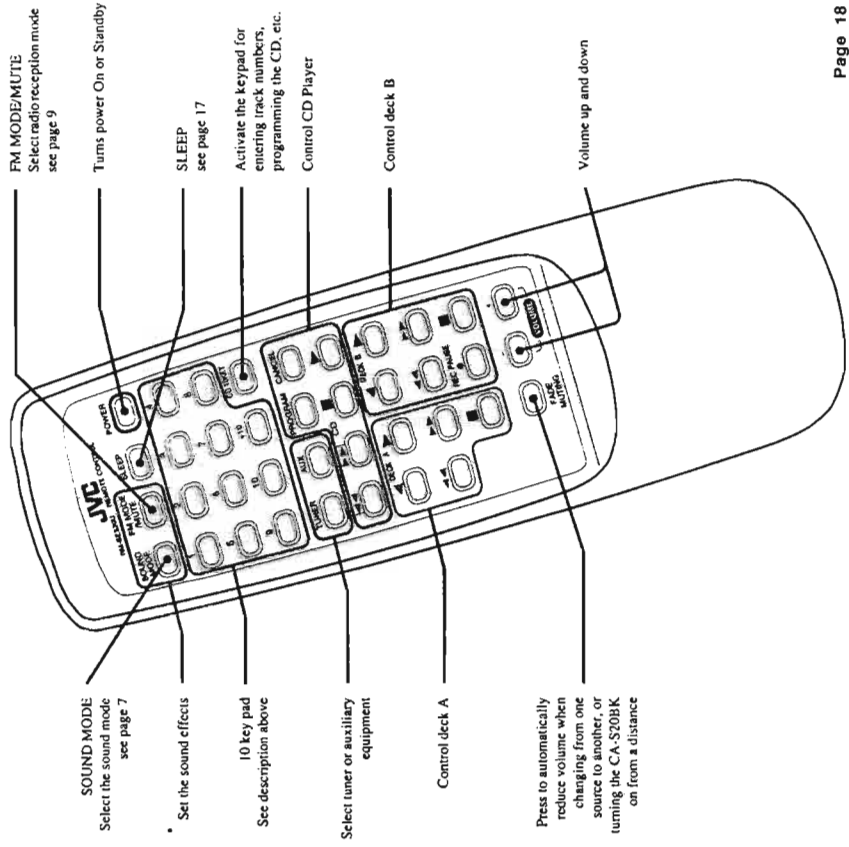

Care and Maintenance—General Notes

Compact Discs

Handle your compact discs, cassette tapes, and tape deck carefully, and they will last a long time.



- Remove the CD from the case by holding it at the edges while pressing the center hole lightly.
- Do not touch the shiny surface of the CD, or bond the CD.



- Place the CD into the open tray with the label facing up.



- Put the CD back in its case after use to prevent warping.
- Be careful not to scratch the surface of the CD when placing it back in the case.
- Avoid exposure to direct sunlight, temperature extremes, and moisture.

Cassette Tapes

- If the tape is loose in its cassette, take up the slack by inserting a pencil in one of the reels and rotating.
- If the tape is loose, it may get stretched, cut, or caught in the cassette.

- Do not touch the tape surface.

- Do not store the tape:
 - In dusty places
 - In direct sunlight or heat
 - In moist areas
 - On a TV or speaker
 - Near a magnet

Tape Deck

- If the heads, capstans, and pinch-rollers of the tape deck become dirty, the following will occur:
 - Impaired sound quality
 - Discontinuous sound
 - Fading
 - Incomplete erasure
 - Difficult recording
- Clean the heads, capstans, and pinch-rollers using a cotton swab moistened with alcohol.

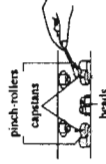

- If the heads become magnetized, it will produce noise or loose high frequencies.
- To demagnetize the heads, turn off the Unit, and use a head demagnetizer (available at electronics and record shops).

On Moisture Condensation

Moisture may condense on the lens inside the unit in the following cases:

- After starting the heating in the room.
- In a damp room.
- If the unit is brought directly from a cold to a warm place.

Should this occur, the unit may malfunction. In this case, leave the unit turned on for a few hours until the moisture evaporates, unplug the AC power cord, and then plug it in again.



CAUTION: Do not use any solvent (for example, conventional record cleaner, spray, thinner, benzine, etc.) to clean a CD.

In general, you will have the best performance by keeping your tapes, CDs, and the mechanism clean.

- Store tapes and CDs in their cases, and keep them in cabinets or on shelves.
- Keep the tape deck tape carriers and the CD tray closed when not in use.

Description of Major LSIs

■ HD4074019FS (IC781) : CD/Tuner controller

1. Terminal Layout

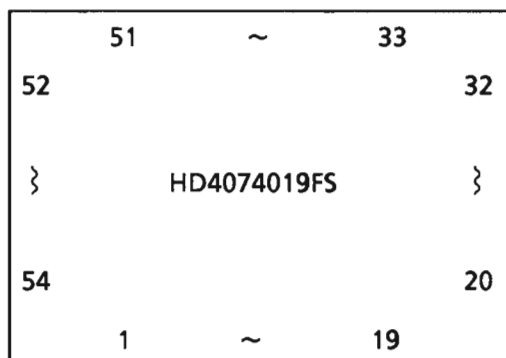

2. Terminal Functions

Pin No.	Symbol	I/O	Function	Pin No.	Symbol	I/O	Function
1	T.DATA	--	Data from IC102	31~36	K00~K05	I	Key matrix input
2	T.CE	I	Chip select signal to IC102	37~38			Not used.
4~7	TEST		Tuner chip selewct	39~42	K10~K13	I	Key matrix input
8	KEY ON	I/O	"H" with key on	43	RESET	--	GND
9	STEREO	I	Input for 'STEREO' indication	46	TEST		pull up
10	TUNED	I	Input for 'TUNED' indication	47	GND	--	
11	INH IN	I	Inhibition signal	48	CLK	--	Clock to transmit data to IC802 (FL driver)
12	TUNER TEST	--	TEST mode terminal (TP801)	49	DATA	O	Data output to IC102
14	CL SW	I	"L" with the tray closed	50	CS	O	Chip select signal to IC802
15	OP SW	I	"L" with the tray opened	51	DCS IN	I	Compulink signal input
16	CD TEST	--	Test mode terminal (T.P.2)	52	DCS OUT	O	Compulink signal output
17	SCOR	I	Subcord synchronizing signal is input	53	LOCK	I	Input terminal for LOCK signal
18	L.ON	O	Laser control signal	54	SENS	I	nput terminal for sens signal
19	XCX	O	"H" with tracking loop is off	55	X \overline{RST}	O	Reset signal output
20	CLOSE	O	"H" with the tray closing	56	DEF.SW	O	"H" with focus searching
21	OPEN	O	"H" with the tray opening	57	FOK	I	Input terminal for forcus ok signal
22	CLOK	O	Clock for data transmission	58	P.OFF	O	Power control signal to cd section
23	CD DATA	O	Serial data for signal processor of cd	59	P.IND	I	Output terminal for indication of cd
24	XLAT	O	Latch signal for data transmission	60	T.MUTE	--	Muting signal to TUNER section
25	AMP RESET	O	Reset signal to IC901	61	MONO		Not used.
26	VCC	--	Power supply	62	F OUT	O	Frequency output (TP801)
27	SCLK	O	Clock out put for SQSO transmission	63	IF DATA	O	IF DATA out put
28	SQSO	I	Input of Q-data of subcode	64	T.CLK	--	Clock to transmit data to IC102

CA-S20BK

■ HD404719A38FS (IC901) : Deck controller

1. Terminal Layout

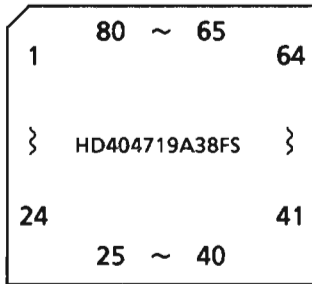

2. Terminal Functions

Pin No.	Symbol	I/O	Function	Pin No.	Symbol	I/O	Function
1	IN11	I	Leaf switch voltage	41	BFR	O	Reel motor control signal (forward)
2	IN12	I	Leaf switch voltage	42	BRR	O	Reel motor control signal (reverse)
3	PRT	I	Input from protector circuit	43	BRC	O	Cam motor control signal (counterclockwise)
4	AD GND	---	Ground for A/D converter	44	BFC	O	Cam motor control signal (clockwise)
5	RESET IN	I	Reset signal from IC801	45	AFR	O	Reel motor control signal (forward)
6	OSC1	---	Oscillation terminal	46	ARR	O	Reel motor control signal (reverse)
7	OSC2	---	Oscillation terminal	47	ARC	O	Cam motor control signal (counterclockwise)
8	LG	---	GND	48	AFC	O	Cam motor control signal (clockwise)
9	---	---	Connected to GND	49	---	---	Connected to GND
10	---	---	Connected to GND	50	ACS2	I	Input of mechanism information (deck A)
11	$\overline{\text{TEST}}$	---	Connected to +5V	51	ACS1	I	Input of mechanism information (deck A)
12	VCC	---	+5V	52	ACS0	I	Input of mechanism information (deck A)
13	$\overline{\text{DCS IN}}$	I	Compulink signal input	53	BCS2	I	Input of mechanism information (deck B)
14	$\overline{\text{DCS OUT}}$	O	Compulink signal output	54	BCS1	I	Input of mechanism information (deck B)
15	FADE	O	Fade recording control	55	BCS0	I	Input of mechanism information (deck B)
16	BIAS	O	Bias circuit control (on/off)	56	SMT	O	Muting control
17	ACAP	O	Drive signal for the capstan motor (A)	57	$\overline{\text{G}}$	O	Output control to IC905,906
18	BCAP	O	Drive signal for the capstan motor (B)	58	RCK	O	Data output to IC905,906
19	AMC	O	Speed control signal for deck A	59	SI	O	Strobe output to IC905,906
20	BMC	O	Speed control signal for deck B	60	AD SCK	O	Clock output to IC905,906
21	APLS	I	Input of reel pulse (Deck A)	61	RMIN	I	Input from remote signal detector
22	BPLS	I	Input of reel pulse (Deck B)	62	SPCLK	O	Clock output to IC803
23	RMT	O	Recording mute control	63	SPDATA	O	Data output to IC803
24	NR	O	Noise reduction control	64	CS	O	Chip select signal to IC803
25	NR REC	O	Mode control of NR (REC/PLAY)	65	MSI	I	Blank detection terminal for music scanning
26	$\overline{\text{H.S.D.}}$	O	Control signal for high-speed dubbing	66	CLK	O	Clock output to IC403 (Tone selector)
27	$\overline{\text{PBCR}}$	O	Playback equalizer control	67	STB	O	Strobe output to IC403 (Tone selector)
28	AI.S.BASS	O	AI.S.BASS indication signal and control.	68	DATA	O	Data output to IC403 (Tone selector)
29	LC	O	Rec. EQ control (Normal speed : CrO ₂)	69	POWER	O	Power control (Power on/off)
30	HC	O	Rec. EQ control (High speed : CrO ₂)	70	SPK	O	Speaker relay control
31	HN	O	Rec. EQ control (High speed : Normal)	71	VOL DOWN	O	Master volume control
32	$\overline{\text{BCR}}$	O	L' when using high position tape	72	VOL UP	O	Master volume control
33	KARAOKE		KARAOKE Indication signal	73	A PLAY	O	H' with deck A playing
34	DISCO		DISCO Indication signal	74	PB MUTE	O	Muting control for cassette decks
35	HALL		HALL Indication signal	75	AD VCC	---	+5V
36	STADIAM	O	STADIAM Indication signal	76	IN 6	I	AMP switch voltage
37	BGM	O	BGM Indication signal	77	IN 7	I	AMP switch voltage
38	CAR	O	CAR Indication signal	78	IN 8	I	DECK switch voltage
39	H.PHONE		H.PHONE Indication signal	79	IN 9	I	DECK switch voltage
40	STD-BY		STD-BY Indication signal	80	IN 0	I	DECK switch voltage

■ LC7218 (IC102) : PLL Synthesizer

1. The main function descriptions

- (1) It makes the local oscillation frequency by the control data from IC901.
- (2) Decode the control signal and transmit the signal for receiving conditions.
- (3) For the best tuning, count the internal-frequency and transmit the data to IC901.

2. Terminal Layout

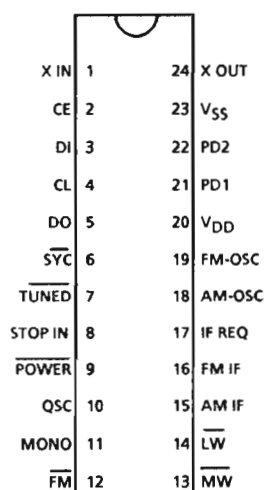

3. Block Diagram

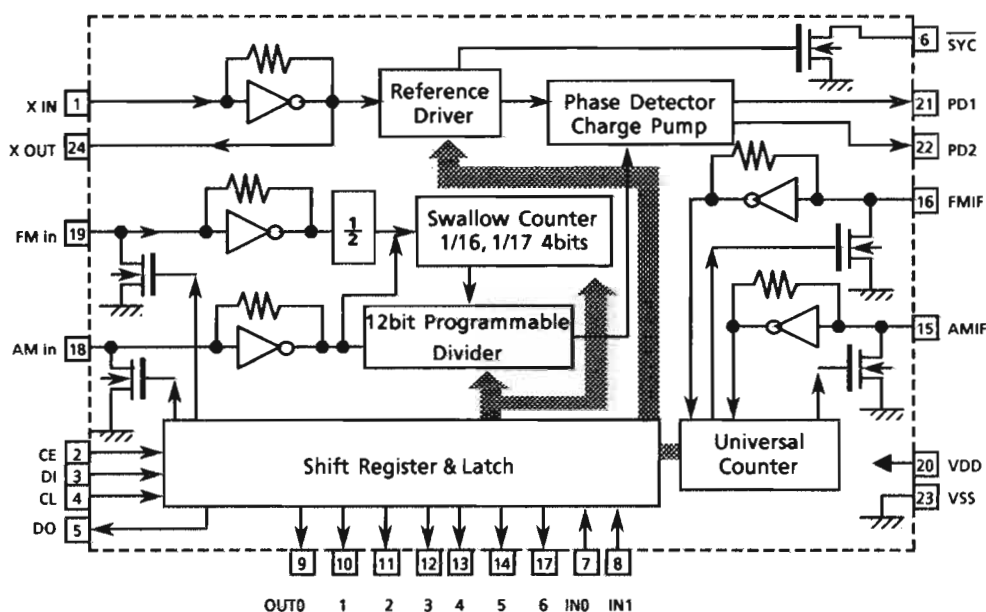

4. Pin Functions

Pin No.	Symbol	I/O	Functions
1,24	X in , X out	I/O	Crystal oscillator (7.2MHz).
2	CE	I	Fix the chip enable to "H" when inputting (DI) and outputting (DO) the serial data.
3	DI	I	Receive the control data from the controller (IC801).
4	CL	I	This clock is used to synchronize data when transmitting the data of DI and DO.
5	DO	O	Transmit the data from LC7218 to the controller which is synchronized with CL.
6	SYC	—	Not used.
7	TUNED	I	Receive the tuned signal from IC104 (LA1266A).
8	STOP IN	—	Connected to GND
9	POWER	—	Not used.
10	QSC	—	Not used.
11	MONO	O	It is "H" on FM-monaural, "L" on FM-Stereo.
12	FM	O	It is "L" on FM mode.
13	MW	O	It is "L" on MW mode.
14	LW	O	It is "L" on LW mode.
15	AM-IF	I	Universal counter input for AM-IF from IC104 (LA1266A).
16	FM-IF	I	Universal counter input for FM-IF from IC104(LA1266A).
17	IF REQ	O	Output the "IF-signal request" to IC104 when the pin-7 (tuned in) goes to "H".
18	AM OSC	I	Input the local oscillator signal of AM.
19	FM OSC	I	Input the local oscillator signal of FM.
20	V _{DD}	—	This is a terminal of power supply.
21	PD1	O	PLL charge pump output: When the local oscillator signal frequency is higher than the reference frequency high level signals will output. When it is lower than the reference frequency, low level signals will output. When it is same as reference frequency signals, it will be floating.
22	PD2	—	Not used.
23	V _{SS}	—	Connected to GND

CA-S20BK

LA1266A (IC104) : FM AM IF AMP & detector

1. The main function descriptions

- (1) Amplify and detect of FM intermodulation frequencies.
- (2) It has local oscillator and mixer for AM, and amplify the AM-IF' signal.

2. Top View

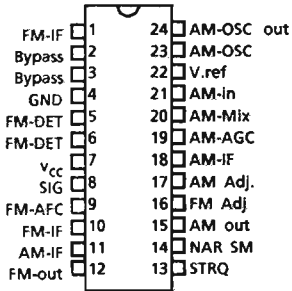

3. Block Diagram

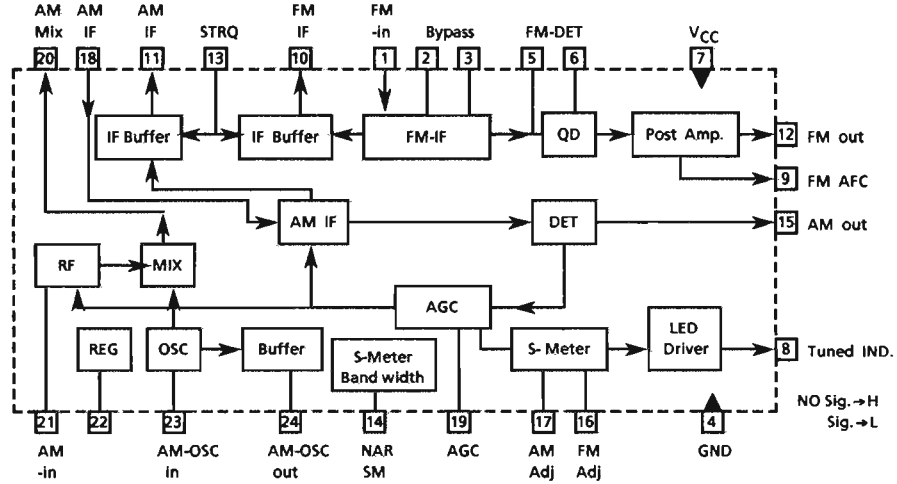

4. Pin Function Description

Pin No.	Symbol	I/O	Functions and Operations
1	FM IF	I	This is an input terminal of FM IF Signal.
2, 3	Bypass	—	Bypass of FM IF Amp.
4	GND	—	This is the device ground terminal.
5, 6	FM DET	—	FM detect transformer.
7	V _{CC}	—	This is the power supply terminal.
8	SIGNAL	O	Mute drive and signal stop drive output when tuning. Active Low
9	FM AFC	O	This is an output terminal of voltage for FM - AFC.
10	FMIF	O	When the IF REQ signal of IC251(LC7218) applies to pin13, the signal of FM IF outputs.
11	AM IF	O	When the IF REQ signal of IC251(LC7218) applies to pin13, the signal of AM IF outputs.
12	FM out	O	FM detection output.
13	STRQ	I	The IF-signals come out from pin10 (FM-IF) or pin11 (AM-IF) while this terminal goes to "High".
14	NAR SM	—	Control the Band-width of AM signal meter.
15	AM out	O	AM detection output.
16	FM Adj	—	For adjust the stop level (or mute level) of FM.
17	AM Adj	—	For adjust the stop level (or mute level) of AM.
18	AM-IF	I	Input of AM IF Signal.
19	AM-AGC	I	This is an AGC voltage Input terminal for AM.
20	AM-MIX	O	This is an output terminal for AM mixer.
21	AM-IN	I	This is an input terminal for AM RF Signal.
22	V.REF	—	Control the Band-width of FM signal meter.
23	AM-OSC	—	This is a terminal of AM Local oscillation circuit.
24	AM-OSC out	O	AM Local Oscillation Signal output.

■ LA3401 (IC105) : FM MPX Detector

1. The main function descriptions

- (1) Detect the FM Multiplex Signal (Stereo signal).
- (2) When receiving FM Stereo Signal, it outputs the signal for indicator.
- (3) AM/FM Audio Amplifier.

(1) Terminal Layout

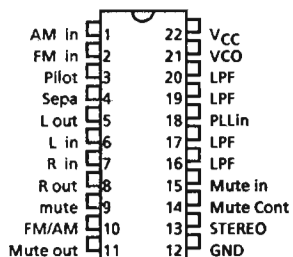

2. Top View & Block Diagram

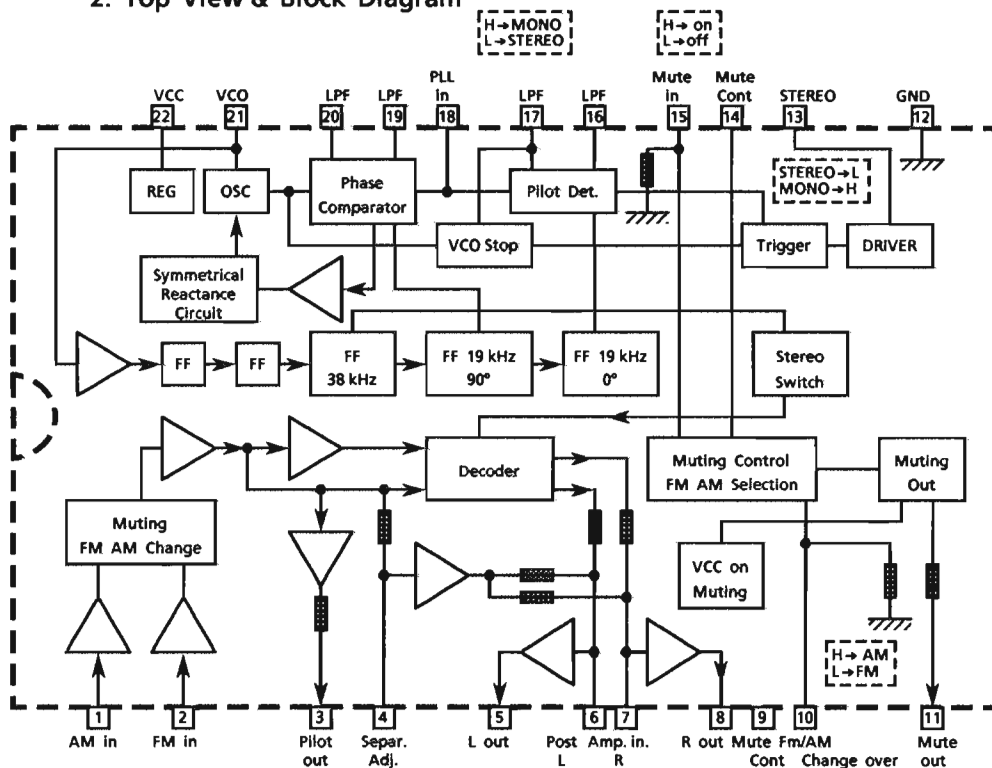

3. Pin Function Description

Pin No.	Symbol	I/O	Functions and Operations
1	AM in	I	This is an input terminal for AM detection signal.
2	FM in	I	This is an input terminal for FM detection signal.
3	Pilot out	O	Output of MPX pilot signal (Connect to Pin18).
4	Sepa. Adj.	—	Separation adjustment.
5	L. out	O	Left channel signal output.
6	L	O	Reversal output of Pin5.
7	R	O	Reversal output of Pin8.
8	R out	O	Right channel signal output
9	Mute Cont	—	The mute time is controlled by the connected capacitor when turning the power switch on.
10	FM/AM	I	Change over the FM/AM input. "H" : AM, "L" : FM
11	Mute out	—	Not use
12	GND	—	Ground terminal.
13	Stereo	O	Stereo indicator output. Stereo : "L", Mono : "H"
14	Mute Cont	—	The mute time is controlled by the connected capacitor when changing over the FM/AM .
15	Mute in	I	Mute signal input. "H" : Mute on, "L" : Mute off.
16	LPF	—	Low pass filter of pilot detector.
17	LPF	—	While this terminal goes to "H", the VCO stop.
18	Pilot in	I	PLL input.
19	LPF	—	Low-pass filter of PLL.
20	LPF	—	Low-pass filter of PLL.
21	VCO	I	Voltage controlled oscillator terminal.
22	V _{CC}	—	Power supply.

■ BA7725S (IC998) :Echo circuit

1. Internal Block Diagram

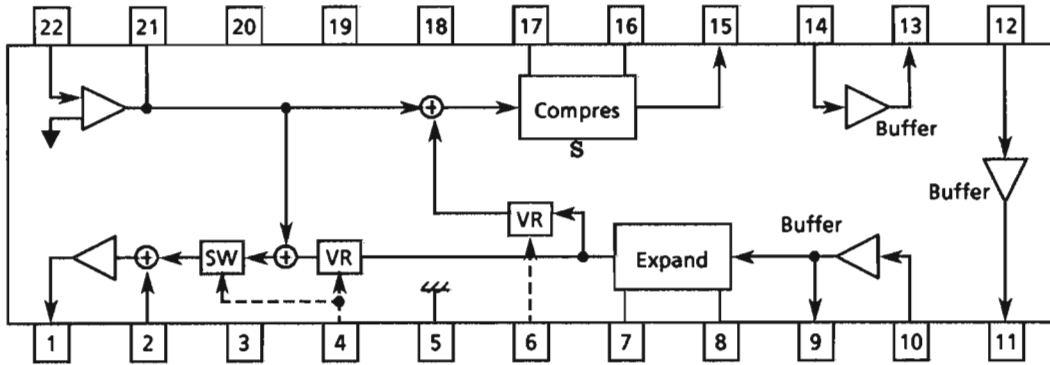

2. Terminal Description

Pin No.	Symbol	Function
1	LINE OUT	Line output
2	LINE IN	Line input
3	NC	Not used
4	ECHO LEV CTRL	Determines echo level. The echo circuit is off when 1 volt is added. The echo level varies according to the voltage from 2 volts to 9 volts.
5	GND	Analog GND
6	LOOP GAIN CTRL	Loop gain control terminal. The gain varies according to the voltage from 2 volts to 9 volts.
7	EXP DET	Detection terminal for expand circuit
8	EXP DET CT	Determines the attack and recovery time of expand circuit
9	EXP BF OUT	Buffer output (Expand circuit side)
10	EXP BF IN	Buffer input (Expand circuit side)
11	DLY BF OUT	Delay buffer output
12	DLY BF IN	Delay buffer input
13	CMP BF OUT	Buffer output (Compress circuit side)
14	CMP BF IN	Buffer input (Compress circuit side)
15	CMP OUT	Compress circuit output
16	CMP DET CT	Determines the attack and recovery time of compress circuit
17	CMP DET	Detection terminal for compress circuit
18	RIPPLE FILTER	A capacitor is connected for ripple elimination filter
19	VCC	Power supply
20	NC	Not used
21	MIC AMP OUT	Mic amp output
22	MIC AMP IN	Mic amp input

■ CXD2500BQ(IC701) : DIGITAL SIGNAL PROCESSOR

1. Outline

The CXD2500BQ is a digital signal processing LSI designed for use in compact disc players. It has the following functions:

- All digital signals for regeneration are processed using one chip.
- The built-in RAM enables high-integration mounting.
- Generation by the use of a digital PLL of bit clock pulses for strobing the EFM signal.
- EFM data demodulation
- Subcode demodulation and subcode Q data error detection
- Digital spindle servo system (incorporating an oversampling filter)

3. Internal Block Diagram

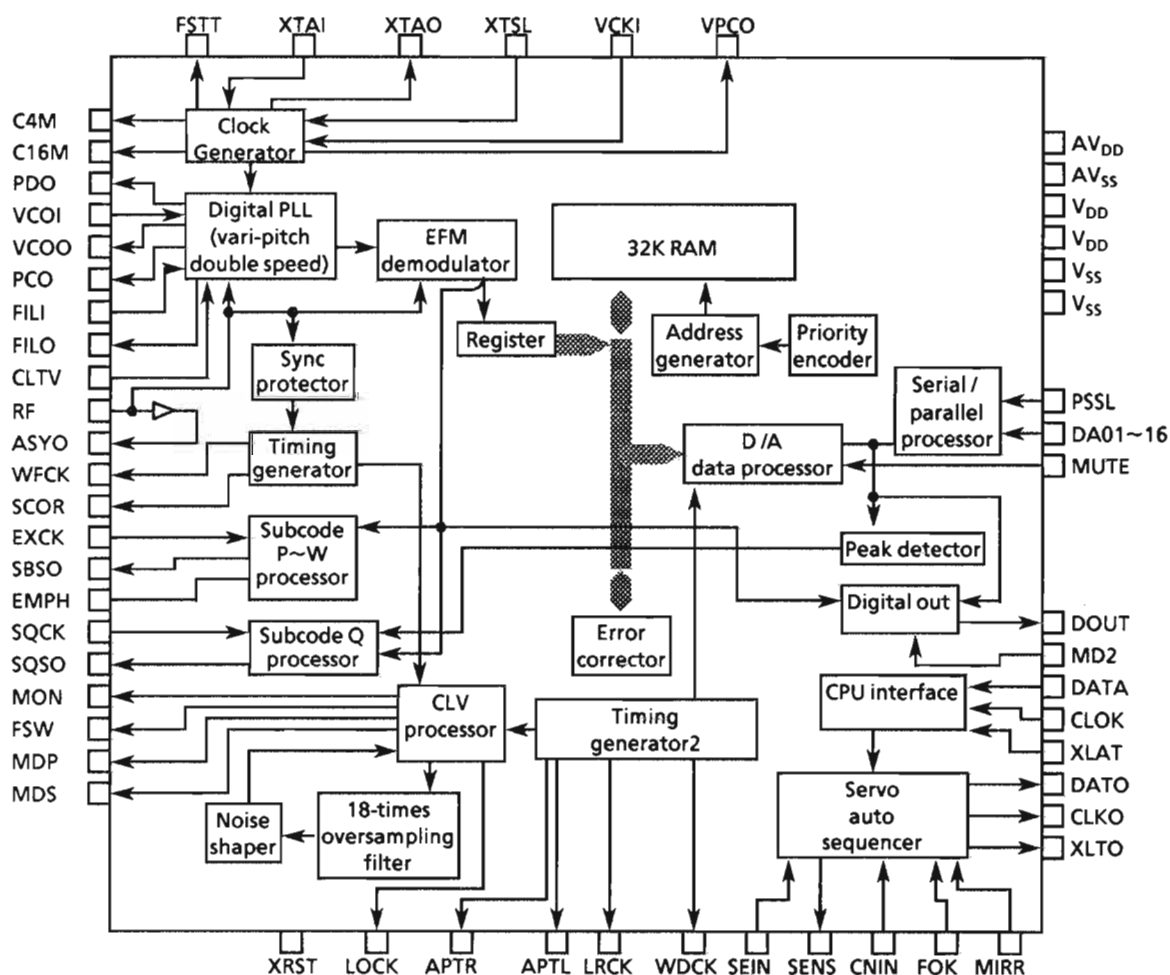

Notes:

- The data at the 64-bit slot is output in 2's complements on an LSB-first basis. The data at the 48-bit slot is output in 2's complements on an MSB-first basis.
- GTOP monitors the state of Frame Sync protection. ("H" : Sync protection window released)
- XUFG is a negative Frame Sync pulse obtained from the EFM signal before Frame Sync protection is effected.
- XPLCK is an inversion of the EFM PLL clock. The PLL is designed so that the falling edge of XPLCK coincides with a change point of the EFM signal.
- The GFS signal turns "H" upon coincidence between Frame Sync and the timing of interpolation protection.
- RFCK is a signal generated at 136- μ s periods using a crystal oscillator.
- C2PO is a signal to indicate a data error.
- XRAOF is a signal issued when a jitter margin of $\pm 28F$ is exceeded by the 32K RAM.

2. Terminal Layout

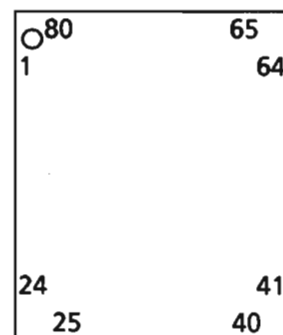

CA-S20BK

4. Terminal Function

Pin No.	Symbol	I/O	Description
1	FOK	I	Focus OK input pin. Used for SENS output and servo auto sequencer.
2	FSW	O	Non connection
3	MON	O	Output for spindle motor ON / OFF control.
4	MDP	O	Output for spindle servo control.
5	MDS	O	Output for spindle servo control (Non connection).
6	LOCK	O	This terminal is "H" when the GFS signal sampled at 460Hz is "H". It turns "L" when the GFS signal turns out "L" 8 or more times in succession.
7~9	—	—	Non connection
10	TEST	I	Test pin (Normally at 0V)
11	PDO	O	Output of charge pump for analog EFM PLL (Non connection).
12	Vss	—	GND
13~16	—	—	Non connection
17	VCKI	I	Clock input from external VCO for vari-pitch control. $f_c = 16.9344\text{MHz}$.
18	FILO	O	Output of filter for master PLL (Slave = Digital PLL)
19	FILI	I	Input to filter for master PLL.
20	PCO	O	Output of charge pump for master PLL.
21	AVss	—	Analog GND
22	CLTV	I	VCO control voltage input for master PLL.
23	AV _{DD}	—	Analog power supply
24	RF	I	EFM signal input
25	TEST2	I	TEST pin (Connected to GND)
26	TEST3	I	TEST pin (Connected to GND)
27	ASYO	O	EFM full-swing output
28	TEST4	I	TEST pin (Connected to GND)
29	NC	—	Non connection
30	PSSL	I	Input used to switch the audio data output mode. "L" for serial output, "H" for parallel output.
31	WDCK	O	D / A interface for 48-bit slot. Word clock $f = 2F_s$.
32	LRCK	O	D / A interface for 48-bit slot. LR clock $f = F_s$.
33	V _{DD}	—	Power supply
34	DA16	O	Output DA16(MSB) when PSSL = 1 or serial data from 48-bit slot(2's complements, MSB first) when PSSL = 0.
35	DDA15	O	Output DA15 when PSSL = 1 or bit clock from 48-bit slot when PSSL = 0.
36~51	—	—	Non connection
52	VSS	—	GND
53	XTAI	I	Input to 16.9344MHz Xtal oscillation circuit or 33.8688MHz input.
54	XTAO	O	Output of 16.9344 MHz Xtal oscillation circuit.
55	XTSL	I	Xtal selection input pin. "L" for 16,344MHz Xtal, "H" for 33.8688 MHz Xtal.
56~58	—	—	Non connection
59	MD2	I	Digital-Out ON/OFF control. "H" for ON, "L" for OFF.
60	DOUT	O	Digital-Out output pin.
61	EMPH	O	H : emphasis on L : emphasis off
62	—	—	Non connection
63	SCOR	O	Turns "H" when subcode Sync S0 or S1 is detected.
64	SBSO	O	Serial output of Sub P to W.
65	EXCK	I	Clock input for reading SBSO.
66	SQSO	O	Outputs 80-bit Sub Q and 16-bit PCM peak-level data.
67	SQCK	I	Clock input for reading SQSO.
68	MUTE	I	"H" for muting, "L" for release.
69	SENS	O	SENS output to CPU.
70	XRST	I	System reset. "L" for resetting.
71	DATA	I	Inputs serial data from CPU.
72	XLAT	I	Latches serial data input from CPU at falling edge.
73	V _{DD}	—	Power supply(+ 5V)
74	CLOK	I	Inputs serial data transfer clock from CPU.
75	SEIN	I	Inputs SENSE from SSP.
76	CNIN	I	Inputs track jump count signal.
77	DATO	O	Outputs serial data to SSP.
78	XLTO	O	Latches serial data output to SSP at falling edge.
79	CLKO	O	Outputs serial data transfer clock to SSP.
80	MIRR	I	Inputs mirror signal to be used by auto sequencer when jumping 128 or more tracks.

■ CXA1571S(IC702) : RF AMP FOR COMPACT DISC

1. Outline

The CXA1571S IC for compact disc # -point method optical pickup output has following functions.

- RF amplifier
- Focus error amp
- Tracking error
- APC circuit

2. Internal Block Diagram

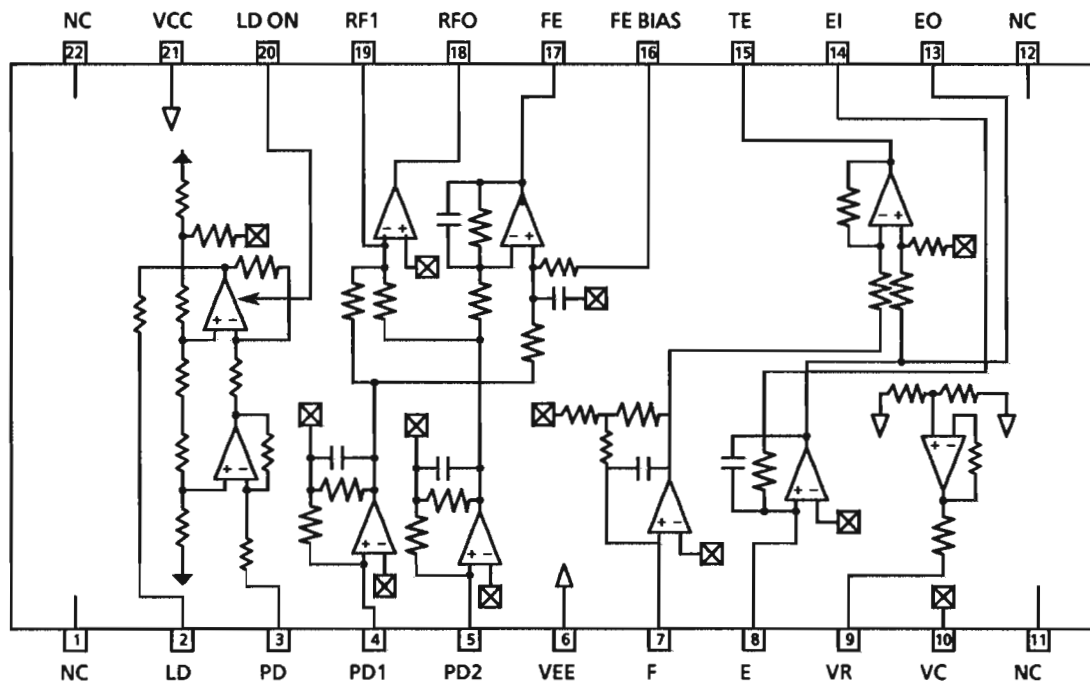

3. Pin Description

Pin No.	Symbol	I/O	Description
2	LD	O	APC amp output pin.
3	PD	I	APC amp input pin.
4	PD1	I	RF I-V amp inverted input pins; they are connected to the A + C and B + D pins of the photodiode and receive current input.
5	PD2	I	
7	F-IN	I	F and E I-V amp inverted input pin; they are connected to Photodiodes F and E and receive current input.
8	E-IN	I	
9	VR	O	$(VCC + VEE) / 2$ DC voltage output pin.
10	VC	I	VC intermediate voltage input pin; when dual $\pm 5V$ power supplies are used, this pin is connected to GND; for a single +5V power supply, it is connected to the VR pin.
13	EO	O	Monitor output pin for I-V amp E.
14	EI	I	Gain adjustment pin for I-V amp E.
15	TE	O	Tracking error amp output pin.
16	FE-BIAS	I	Bias adjustment pin for the mon-inverted side of the focus error amp.
17	FE	O	Focus error amp output pin.
18	RFO	O	RF amp output pin.
19	RFI	I	RF inverted side input pin; the resistor connected between this pin and the RFO pin determines the gain of the RF amp.
20	LD-ON	I	This pin switches the APC amp on / off: on for VCC, off for ground.

CA-S20BK

■ CXA1372S (IC703) : RF SIGNAL PROCESSING SERVO AMPLIFIER

1. Outline

The CXA1372S is a bipolar IC developed for RF signal processing (focus OK, mirror, defect detection, EFM comparator) and servo control.

2. Functions

- Auto asymmetry control
- Focus OK detection circuit
- Mirror detection circuit
- Defects detection, counter measures circuit
- EFM comparator
- Focus servo control
- Tracking servo control
- Sled servo control

3. Terminal Layout

TE	1	48	TZC
TDFCT	2	47	DVEE
ATSC	3	46	RFO
FZC	4	45	RFI
FE	5	44	CP
FDFCT	6	43	CB
VC	7	42	DVCC
FGD	8	41	CC2
FS3	9	40	CC1
FLB	10	39	FOK
FEO	11	38	EFM
FE-	12	37	ASY
SRCH	13	36	DFCT
TGU	14	35	MIRR
TG2	15	34	DGND
AVCC	16	33	SENS
TAO	17	32	C.OUT
TA-	18	31	XRST
SL+	19	30	DATA
SLO	20	29	XLT
SL-	21	28	CLK
FSET	22	27	LOCK
ISET	23	26	DIRC
SSTOP	24	25	AVEE

4. Internal Block Diagram

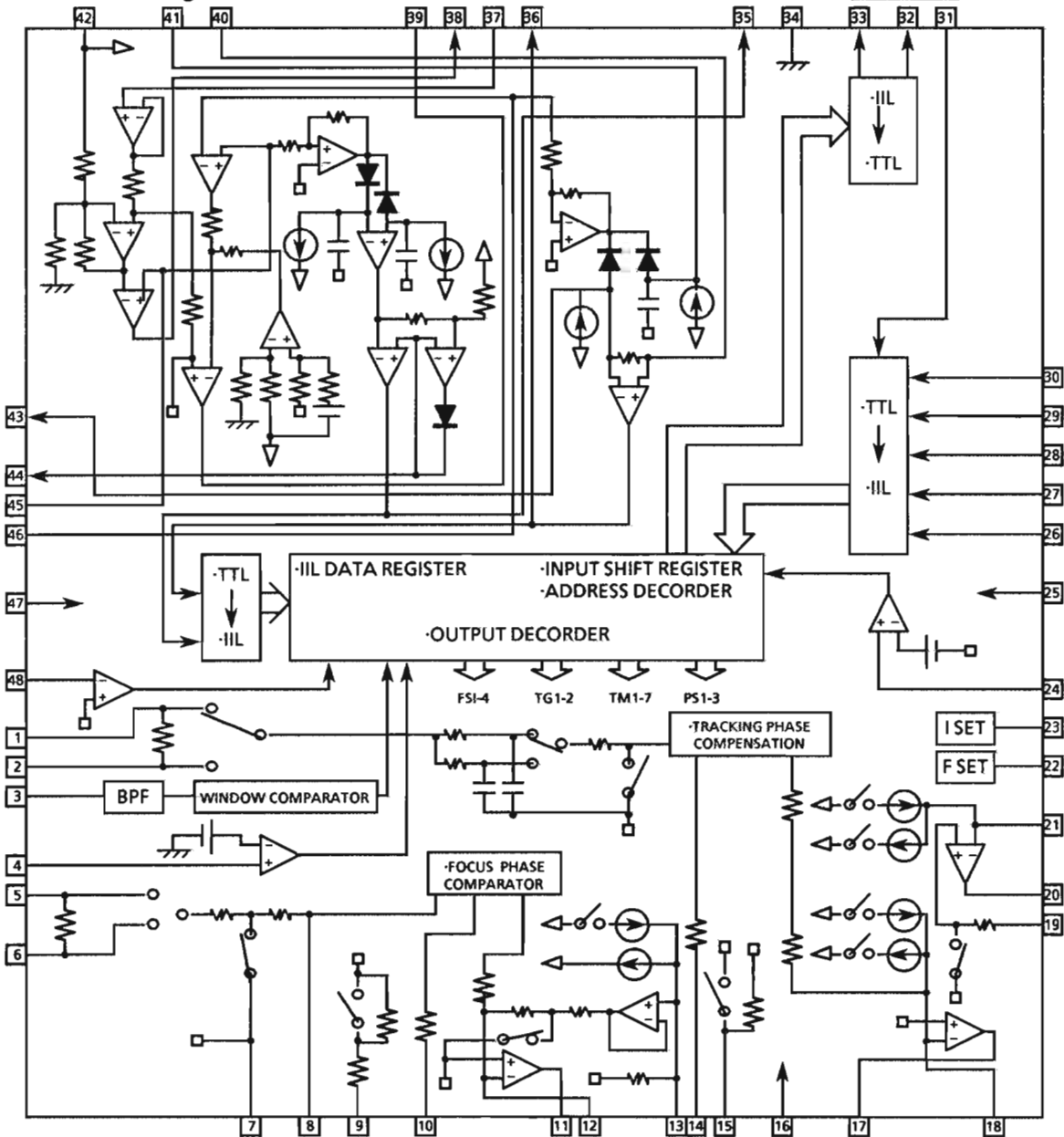

5.Pin Functions

Pin No	Symbol	I/O	Function
1	TE	I	Input pin of tracking error amplifier.
2	TDFCT	I	Capacitor connecting pin for time constant during defects.
3	ATSC	I	Window comparator input pin for ATSC detection.
4	FZC	I	Pin for focus zero-cross comparator input.
5	FE	I	Input pin of focus error.
6	FDCT	I	Capacitor connecting pin for time constant during defect functions.
7	VC	I	Center voltage input pin. For dual power: GND For single power supply: (VCC + GND)/2
8	FGD	I	Connect a capacitor between this pin and pin3 to reduce high-frequency gain.
9	FS3	I	The high-frequency gain of the focus servo is switched through FS3 ON and OFF.
10	FLB	I	Time constant external pin to raise the low bandwidth of the focus servo.
11	FEO	O	Focus drive output.
12	FE-	I	Inverse input for focus amplifier.
13	SRCH	I	Time constant external pin for formation of focus search waveform.
14	TGU	I	Time constant external pin for the selection of tracking high band gain.
15	TG2	I	Time constant external pin for the selection of tracking high band gain.
16	AVCC	--	Power supply
17	TAO	O	Tracking drive output.
18	TA-	I	Inverse input pin for tracking amplifier.
19	SL+	I	Non- inverse input pin for sled amplifier.
20	SLO	O	Sled drive output.
21	SL-	I	Inverse input pin for sled amplifier.
22	F SET	I	Pin to set peak frequency of focus tracking phase compensation and fo of CLV LPF.
23	I SET	I	Current is input to determine focus search, track jump, and sled kick height.
24	S STOP	I	Limit SW ON/OFF signal detection pin for disc inner periphery detection.
25	AVEE	--	- 5V
26	DIRC	I	Pin for one-track jump. Contains 47kΩpull-up resistor.
27	LOCK	I	At "L" sled runaway prevention circuit operate. Contains a 47kΩpull-up resistor.
28	CLK	I	Serial data transfer clock input from CPU.
29	XLT	I	Latch input from CPU.
30	DATA	I	Serial data input from CPU.
31	XRST	I	Reset input pin, reset at "L".
32	C.OUT	O	Track number count signal output.
33	SENS	O	Outputs FZC, AS, TZC and S STOP through command from CPU.
34	DGND	--	GND
35	MIRR	O	MIRR comparator output pin.
36	DFCT	O	Output pin of DEFECT comparator.
37	ASY	I	Input pin of auto asymmetry control.
38	EFM	O	Output pin of EFM comparator.
39	FOK	O	Output pin of FOK comparator.
40	CC1	I	Output pin of DEFECT bottom hold.
41	CC2	O	Input pin for the capacitance coupled output of DEFECT bottom hold.
42	DVCC	--	- 5V
43	CB	I	Connection pin of DEFECT bottom hold capacitor.
44	CP	I	Connecting pin of MIRR hold condenser. Non-inverted input pin of MIRR comparator.
45	RFI	I	Input pin with coupling capacitor where RF summing amplifier output is connected.
46	RFO	O	Output pin of RF summing amplifier and check point of eye pattern.
47	DVEE	--	- 5V
48	TZC	I	Input pin of tracking zero-cross comparator.

CA-S20BK

■ BU9251S: IC999 (D/A DELAY & A/D)

1. Block Diagram

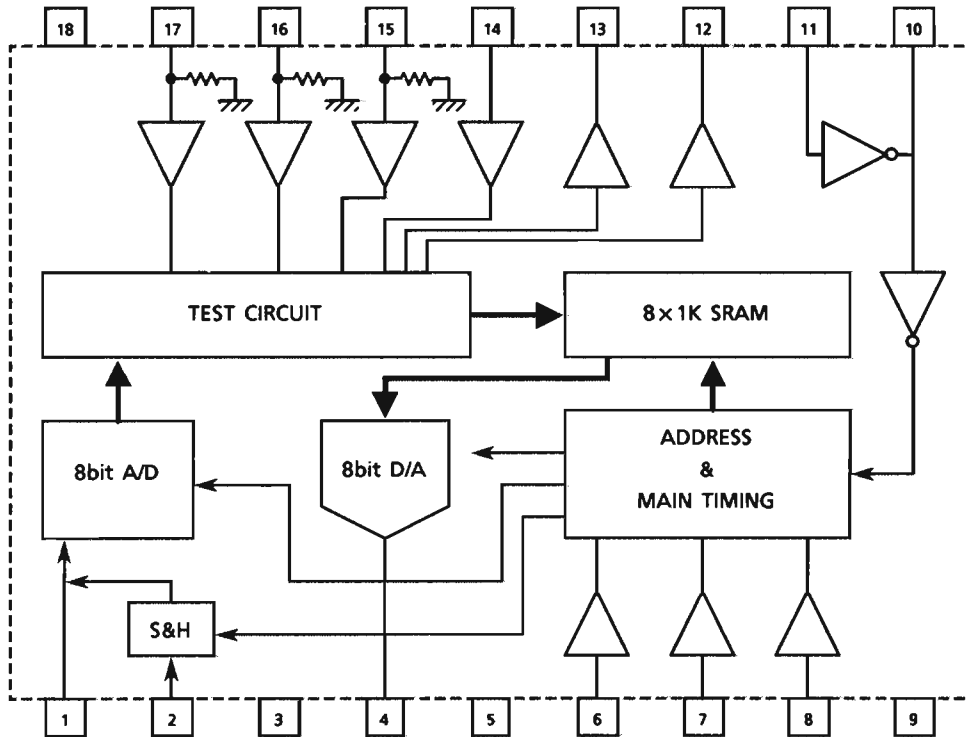

2. Terminal Function

Pin No	Pin Name	Function
1	S&H	Capacitor connected pin for sample and hold
2	AIN	Input for analog signal
3	GND	GND
4	AOUT	Output for analog signal
5	VDD	Power supply
6	DCNT0	Delay time setting
7	DCNT1	Delay time setting
8	DCNT2	Delay time setting
9	GND	GND
10	OSC0	Oscillating 2
11	OSC1	Oscillating 1
12	TDO1	For test (output)
13	TDO0	For test (output)
14	TDIN	For test (input)
15	TST2	Mode setting for test
16	TST1	Mode setting for test
17	TST0	Mode setting for test
18	VCC	Power supply

■ TC9162N(IC403), : Analog Switch

1.Functions

These analog switches are controlled by 14 bit serial date from computer for selecting the source.

2.Terminal Layout & Block diagram

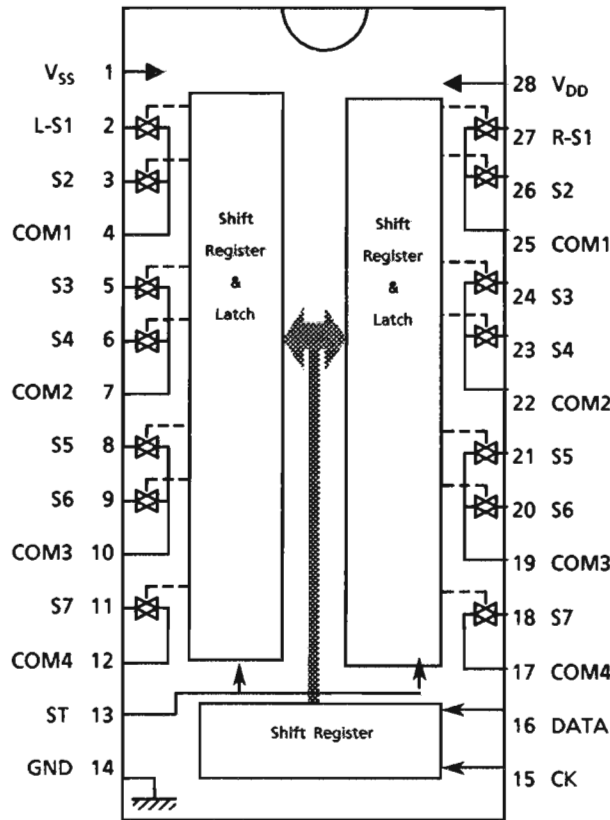

■ LB1541 (IC921~924) : Motor Driver

1. Terminal Layout

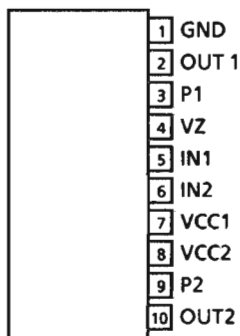

2. Internal Block Diagram

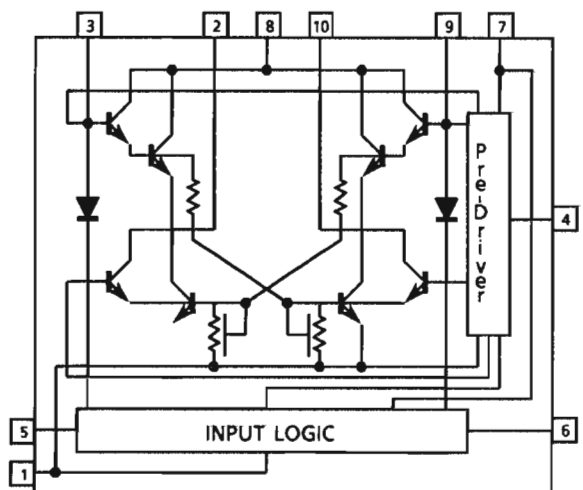

3. Terminal Function

IN 1	IN 2	OUT 1	OUT 2	MOTOR
H	L	H	L	CLOCKWISE
L	H	L	H	COUNTER-CLOCKWISE
H	H	OFF	OFF	WAITING
L	L	OFF	OFF	WAITING

CA-S20BK

■ BA8221N (IC351) : ALC

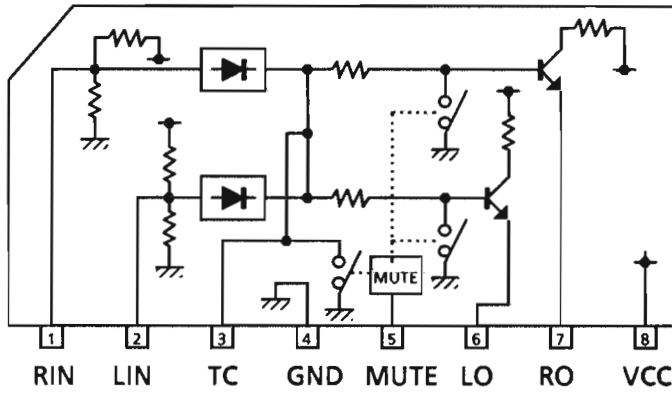

■ BA15218N (IC871, IC851)
... Dual OP Amp

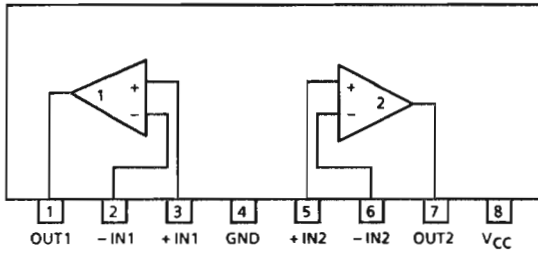

■ IPC1228HC (IC202)
... Dual OP Amp

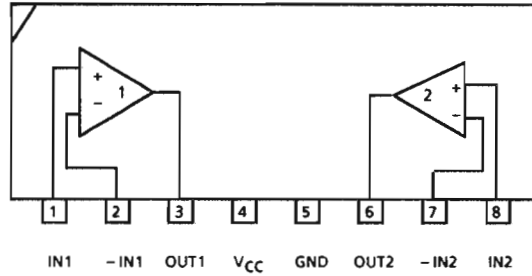

■ HA12135A (IC381) :
Noise Reduction Amplifier

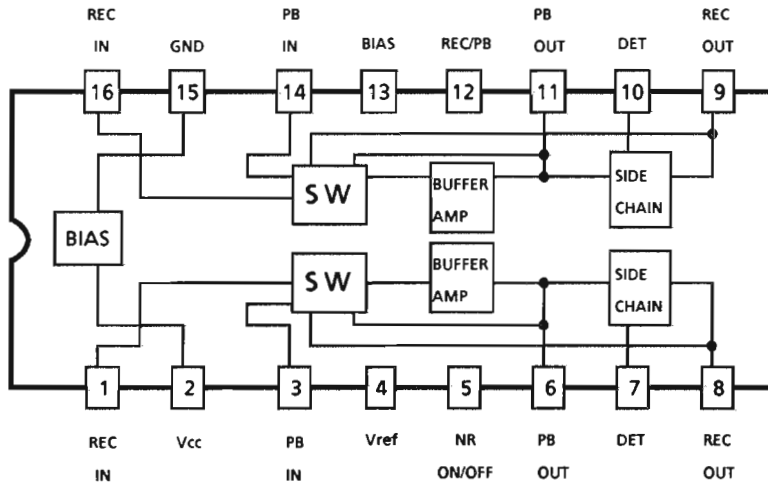

Internal Connections of the FL Display

ELU0001-173

(1) Grid Layout

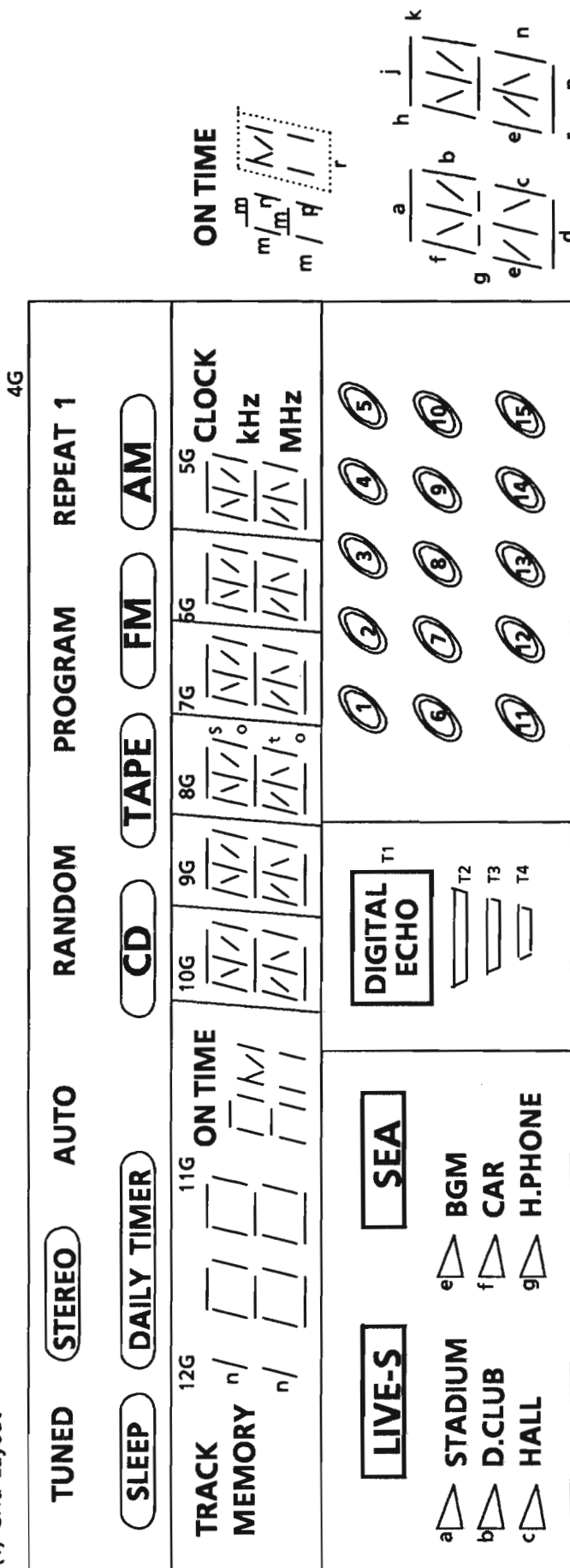

(2) Pin Connections (UPPER)

TERMINAL NO.	68	67	66	65	64	63	62	61	60	59	58	57	56	55	54	53	52	51	50	49	48	47	46	45	44	43	42	41	40	39	38	37	36	35
ELECTRODE	F1	F1	F1	NP	a	b	c	P	P	P	g	h	i	k	s	m	n	p	r	d	t	P	12G	11G	10G	9G	8G	7G	6G	5G	4G	1G	F2	F2

(LOWER)

TERMINAL NO.	18	19	20	21	22	23	24	25	26	27	28	29	30	31	32	33	34	1	2	3	4	5	6	7	8	9	10	11	12	13	14	15	16	17
ELECTRODE	NC	NC	NC	NC	NC	NC	NC	NC	NC	P	T1	T2	T3	T4	NP	F2	F1	F1	F1	F1	NP	NC	2G	3G	2G	NC	NC	NC	NC	NC	NC	NP	NP	NC

Notes F : Filament G : Grid P : Anode

Disassembly Procedures

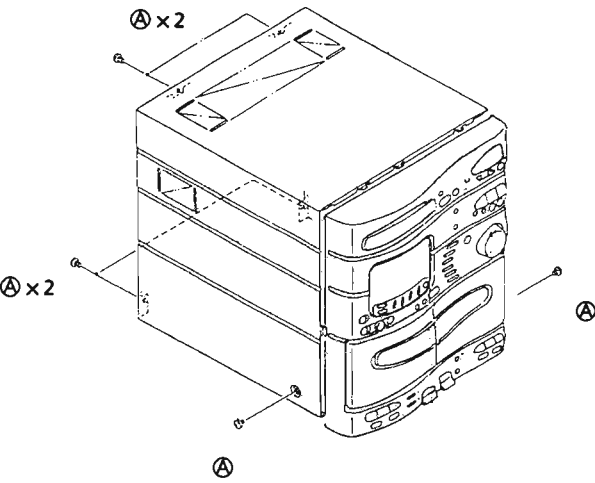
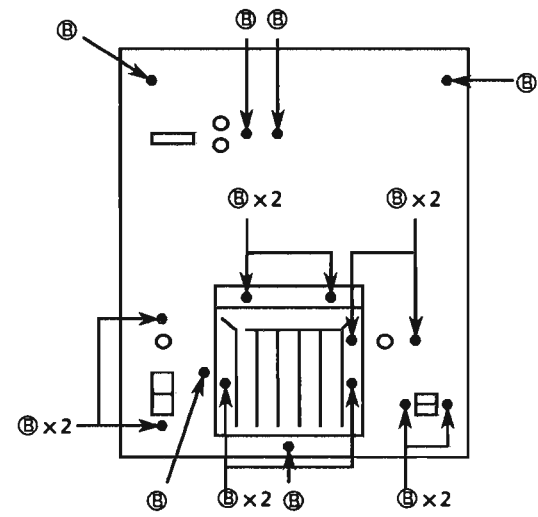
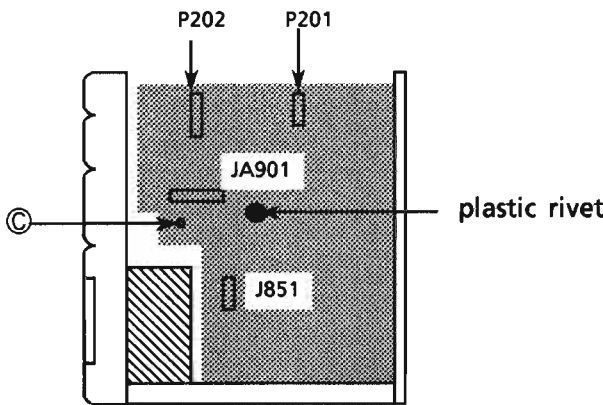
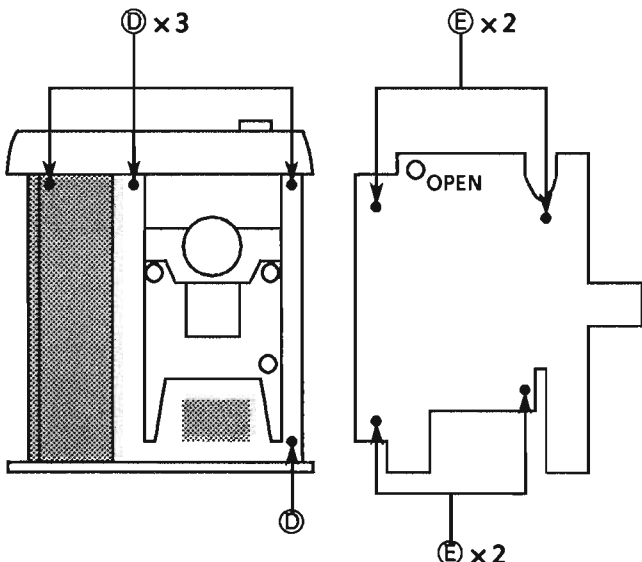
<p>(1) Top cover removal</p> <ol style="list-style-type: none"> 1. Remove 4 screws (A) on the rear side and 2 screws (A) on both sides of the cover. 2. Remove the cover. 	<p>(2) Rear panel removal</p> <ol style="list-style-type: none"> 1. Remove the top cover. 2. Remove the 15 screws (B). 3. Remove the heat sink cover and rear panel.
 <p>Fig1 Front view</p>	 <p>Fig2 Rear view</p>
<p>(3) Tuner and deck PCB (FSJ-001-H) removal</p> <ol style="list-style-type: none"> 1. Remove the top cover. 2. Remove the rear panel (definitely). 3. Remove the screws (C). 4. Remove the plastic rivet. 5. Remove JA901, J851, P201 and P202 which are connected with the PCB. 6. Also remove other connectors if it is necessary to remove the PCB completely. 	<p>(4) CD PCB (FSN-009-1) with CD mechanism assembly removal .</p> <ol style="list-style-type: none"> 1. Remove the top cover. 2. Remove the rear panel. 3. Remove the tuner and deck PCB (FSJ-001-1). 4. Remove the 4 screws (D) fixing the CD PCB. 5. Disconnect the wire P701. 6. Remove the 4 screws (E) on the bottom of the CD PCB. 7. Remove the CD assembly base, disconnecting connectors J601, P602 and P603.
 <p>Fig3 Right side view</p>	 <p>Fig4 Top view Fig5 CD PCB Bottom view</p>

- (5) Front panel assembly removal
1. Remove the top cover.
 2. Remove the rear panel.
 3. Remove the tuner and deck PCB (FSJ-001-1).
 4. Remove the 6 screws (F) on the bottom of the front panel.
 5. Remove the assembly, disconnecting connectors J512, J531, J601 and J991.

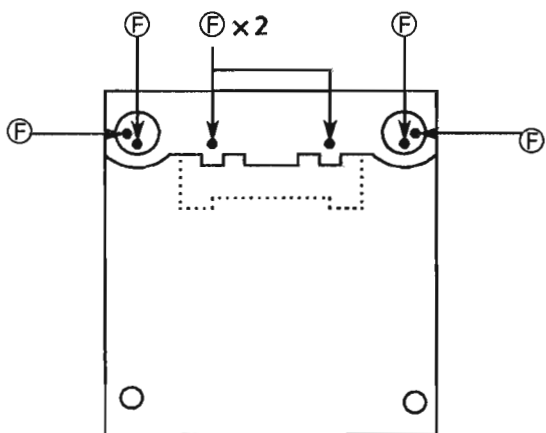

Fig 6 Bottom view

- (6) CD mechanism assembly removal
1. Remove the front panel assembly.
 2. Disconnect the connectors P602, P603.
 3. Turn the screw (G) located under the mechanism to remove the tray out of the loading mechanism.
 4. Remove the screw (H) to remove the tray.
 5. Remove the 2 screws (I) to remove the clamp assembly.
 6. Remove the 3 screws (J).
 7. Remove the CD mechanism assembly.

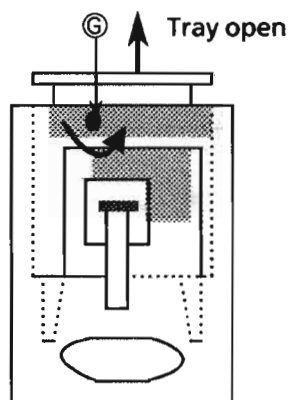

Fig 7 CD Mechanism Bottom view

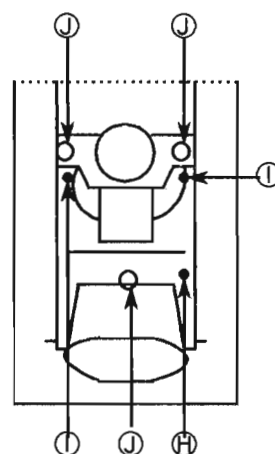

Fig 8 CD Mechanism Top view

- (7) Main volume removal
1. Remove the screws (N)(Fig.10).
 2. Remove the Bracket.
 3. Pull the Main volume knob.
 4. Remove the Nut (O).
 5. Remove the Main volume assembly.

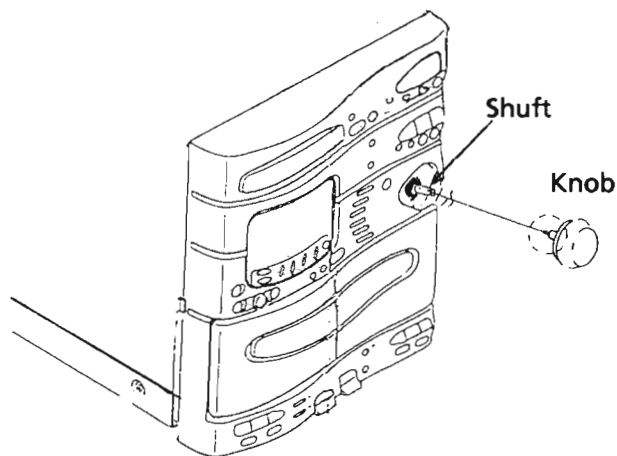
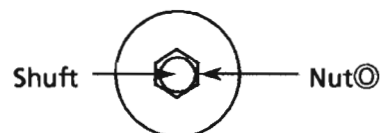

Fig 9 Front panel view

(7) Cassette mechanism with the PCB (FSC-002-3) removal

1. Remove the top cover.
2. Remove the front panel assembly.
3. Disconnect the connectors JB801 ,J931 and P981.
4. Remove the 8 screws (K).
5. Open the cassette doors to remove the cassette mechanism.

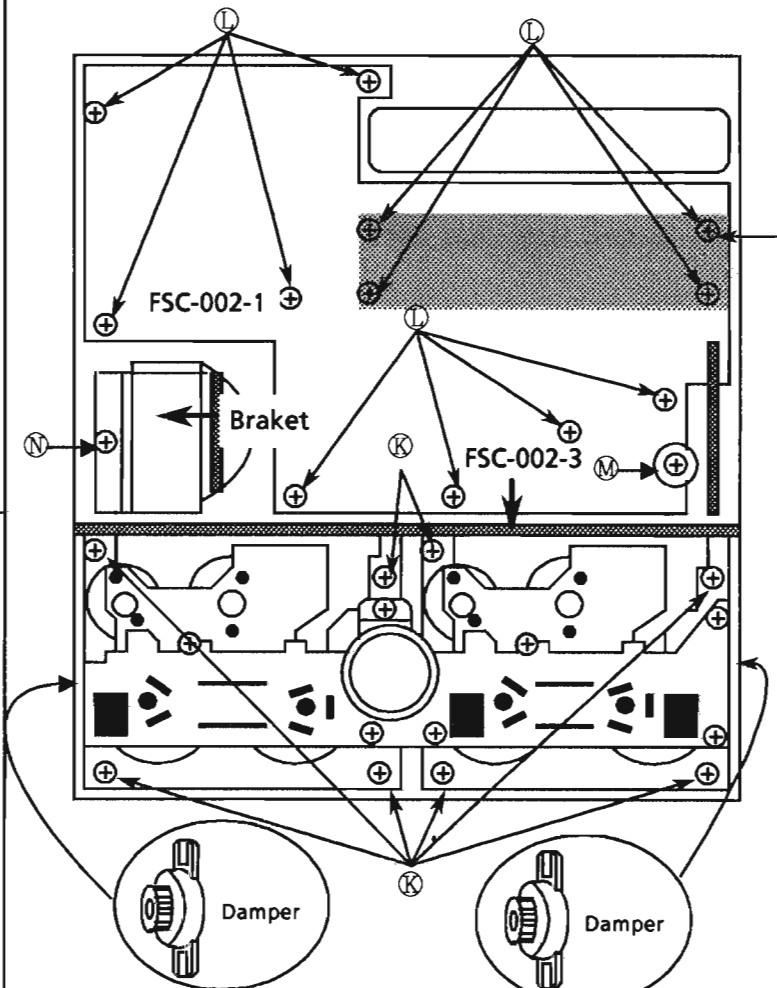

Fig 10 Front panel Rear view

(8) Front PCB(FSC-002-1) removal

1. Remove the top cover.
2. Remove the front panel assembly.
3. Remove the 12 screws (L) screws (M).
4. Remove the screws (N).
5. Remove the Bracket.
6. Remove the Front PCB(FSC-001-1).

(9) Cassette holder removal

1. Remove the cassette mechanism assembly.
2. Remove the spring hooked on the cassette holder (Fig 11).
3. Remove the cassette holder.

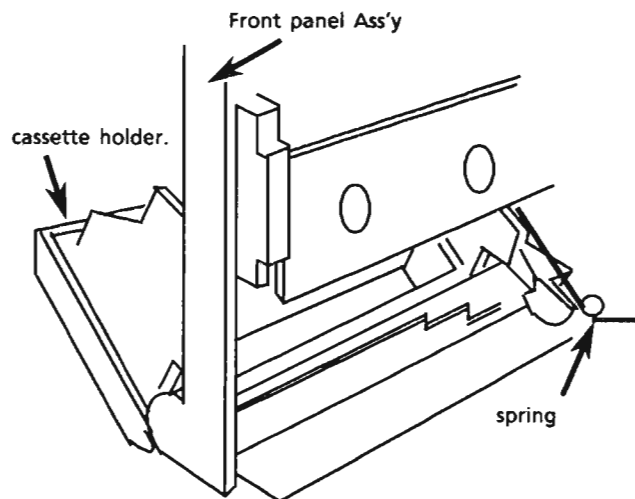

Fig 11 Front view

Disassemble of the CD mechanism assembly

(1) Pickup removal

1. Remove the cd mechanism assembly.
2. Release the shaft to remove the pickup (Fig 12).

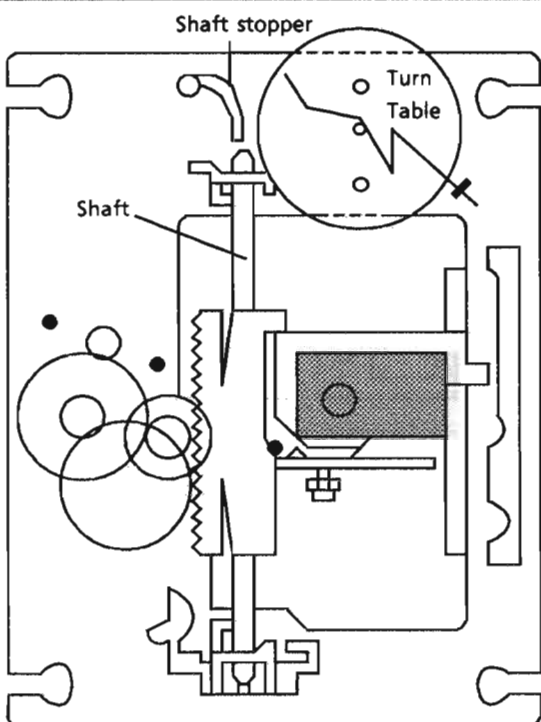

Fig 12 CD mechanism assembly

(2) Spindle motor removal

1. Remove the cd mechanism assembly.
2. Remove the turntable, and remove the two screws retaining the spindle motor.
3. Remove the screws retaining the spindle and feed motor P.C. Board and unsolder it.

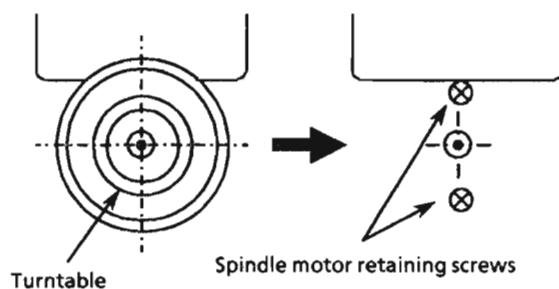

Fig 13

- (4) After inserting the turntable, bond the motor shaft and turntable together (at the section marked by an arrow in fig 15 on the left below).

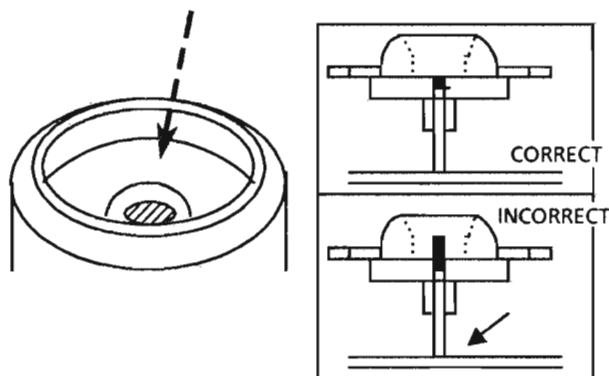

Fig 15

(3) Spindle motor installation

1. Tighten the 2 screws to the same torque.
2. Fasten the spindle and feed motor P.C. board with the screw and solder.
3. Install the turntable. When installing, press straight down at the center of the turntable until the distance from the surface of the mechanism base to the turntable is exactly $19.4 \pm 0.1\text{mm}$.

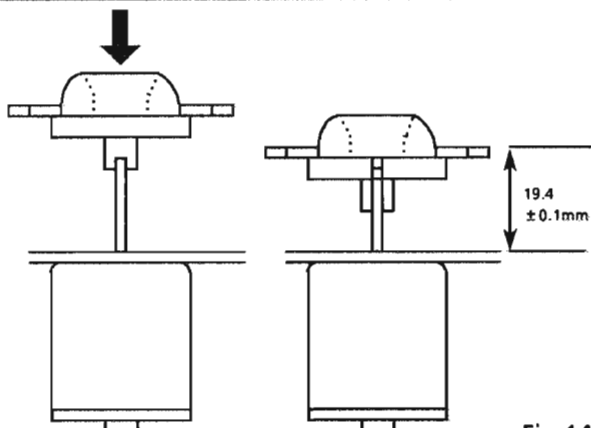

Fig 14

- (5) Use "LOCTITE" #460 bonding agent, and apply as little as possible. Take care not to allow any excess bonding agent to get onto the turntable. Be extremely careful not to allow bonding agent to adhere to the motor bearings (the section marked by an allow in fig 15 on the right).

Disassemble of the cassette mechanism

- (1) Cassette controller PCB (FSC--002-3) removal
1. Remove the cassette mechanism assembly with the PCB.
 2. Remove the 2 screws (A).

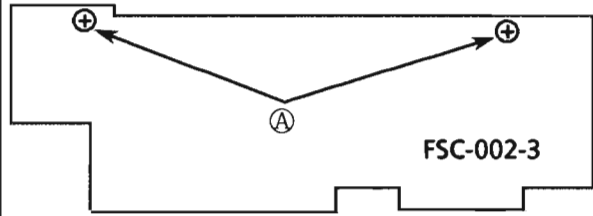

Fig 16

- (2) Head assembly removal
1. Remove the cassette mechanism assembly.
 2. Remove the FPC holder (Fig 19).
 3. Remove the 3 screws (I) fixing the head assembly (Fig 18).

※ Note

The direction of the head is changed with the head gear. When servicing, install the head gear according to the direction of the head. Refer to fig 18.

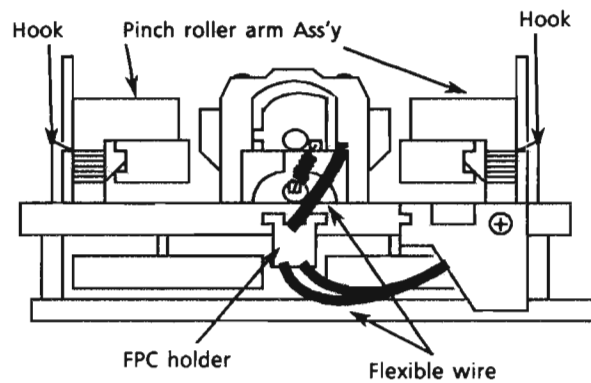

Fig 17

- (3) Pinch roller arm assembly removal
1. Release the hook holding the pinch roller arm assembly to remove the assembly (Fig 19).

- (4) Capstan motor removal
1. Remove the cassette mechanism assembly.
 2. Remove the cassette controller PCB.
 3. Remove the screw (D) to remove the echo PCB (Fig 19).
 4. Remove the 7 screws (E), (F) fixing the bracket (Fig 20).
 5. Remove the motor with the bracket.
 6. Remove the 2 screws fixing the motor and the bracket.

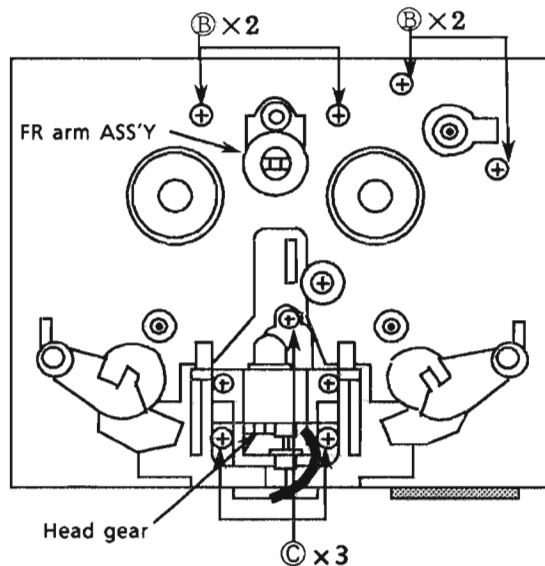

Fig 18

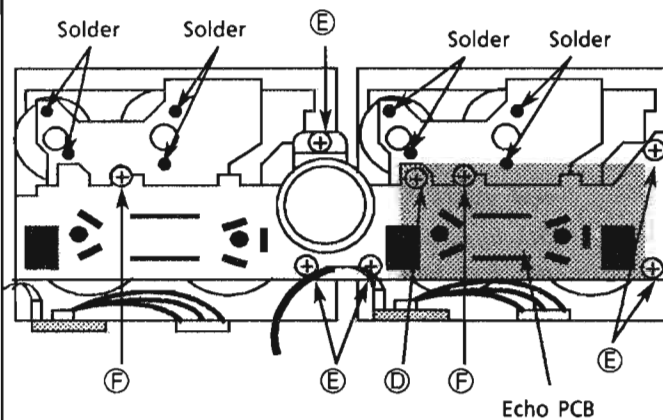

Fig 20

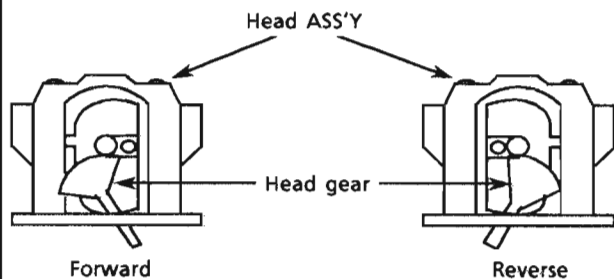

Fig 19

(5) Reel and cam motor PCB

with reel and cam motor removal

1. Remove the cassette mechanism assembly.
2. Remove the cassette controller PCB (FSC-002-3).
3. Remove the 7 screws ⑤, ⑥ fixing the bracket (Fig 20).
4. Remove the motor with the bracket.
5. Remove the 4 screws ③ fixing the reel and cam motor.
6. Unsolder the reel and cam motor PCB.
7. Remove the PCB with motor.
Be careful so that stress is not added to the terminals of the motor.

(6) Fly wheel removal

1. Remove the cassette mechanism assembly.
2. Remove the cassette controller PCB.
3. Remove the 7 screws ⑤, ⑥ and the bracket (Fig 22).

* The oil on the capstan must be wiped out after re-assembling.

※To install the bracket

1. Install the belt of mechanism A as shown in fig 22.
2. Assemble the mechanism A and the bracket with the capstan motor.
3. Hang the belt of the mechanism A to the motor pulley using a tweezers and the like.
4. Hang the part ④ to the Idler pulley.
5. Install the mechanism B installed the belt as shown in fig 23 to the bracket which is assembled with the mechanism A.
6. Hang the part ⑦ to the motor pulley using a tweezers and the like.

(6) Cam switch PCB removal

1. Remove the fly wheel.
2. Remove the screw fixing the PCB.
3. Remove the hooks fixing the PCB to remove the cam switch.
When assembling the cam switch, install it so that the part ① meets the part ① (Fig 24).

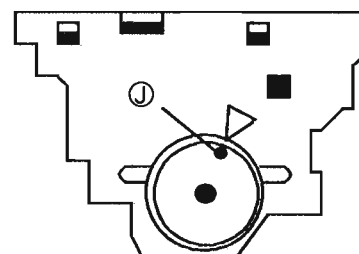
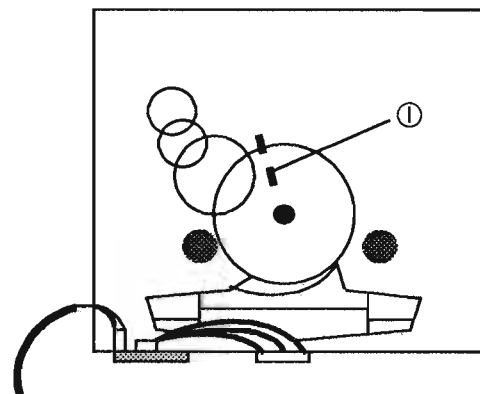
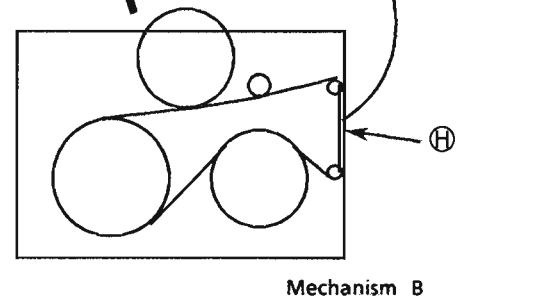
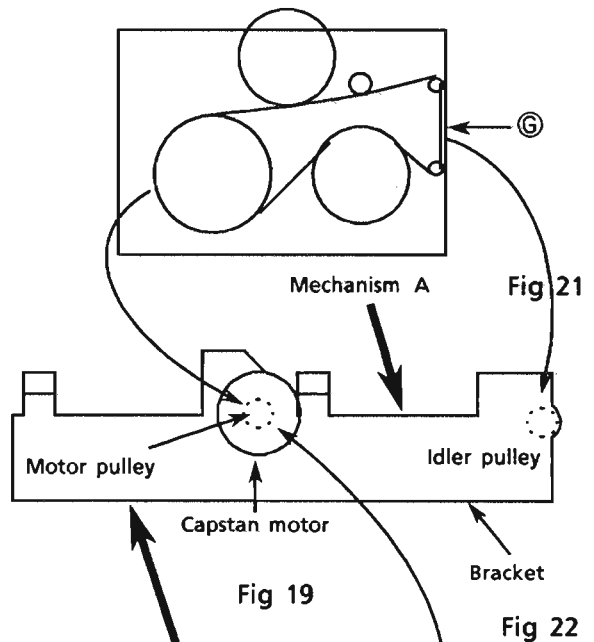

Fig 24

Adjustment Procedures

■ Tuner section

(1) Clock Adjustment

1. After connecting W649 and W650 with some wire, connect ac power cord into ac outlet.
2. Confirm that the display is off and remove the wire.
3. Connect a frequency counter to W774 and W650.
4. Adjust TC781 so that the frequency becomes $34952.5 \pm 0.15\text{Hz}$.

(2) Tuning voltage

Confirm the voltages in the table below at TP101. If the voltages are not satisfied, replace T101 for AM or FE101 for FM.

FM Tuning voltage (Unit : V)

Frequency	FM		AM	
	76MHz	108MHz	522kHz	1629KHz
Tuning voltage	1.6 ± 1.0	8.0 ± 2.0	1.0 ± 0.2	7.5 ± 0.8

(3) FM center meter

Receive a broadcast by using the function of 'AUTO STOP'.
Adjust T105 (detector coil) so that the voltage at TP102 becomes $0 \pm 1.5\text{mV}$.

■ CD section

(1) Adjustment measure

Oscilloscope , Test disc (CRG-1117)

(2) Procedures

1) EF balance

- ① Connect TP2(TEST) with TP4(GND).
- ② Connect a oscilloscope between TP8(TEIN) and TP4(GND) and play the test disc.
- ③ Adjust R684 so that the center voltage of the waveform becomes $0 \pm 0.05\text{V}$.

2) Gain adjustment

If the gain is out of adjustment, the symptoms below will appear.

● Gain too low

Focus gain : Focus is not obtained and disc does not rotate.

Tracking gain : Mechanical shock occurs easily and sound is interrupted. Or time counter display stops counting.

● Gain too high

Focus gain : Scratches (on the disc) easily interrupt play, and noise is increased during play.

Tracking gain : Since the follow-up ability of the pickup is too high, the pickup may oscillate and oscillating sound may output.

As described above, the focus and tracking gain adjustment are performed to satisfy mutually contradictory characteristics.

A simplified adjustment procedure is described below. However, since exact adjustment can not be performed prior to adjustments, note(or mark) the positions of the semi-fixed resistors.

If the positions after the adjustment are only different, return the VRs to their original position.

Tracking gain adjustment

1. Connect an oscilloscope to TP 8(TEIN) and TP 4(GND).
2. Load the test disc and press the PLAY button.
3. Adjust R704 (T.GAIN ADJ.) so that the correct waveform as shown in figure 3 is obtain.

Tracking Gain Adjustment

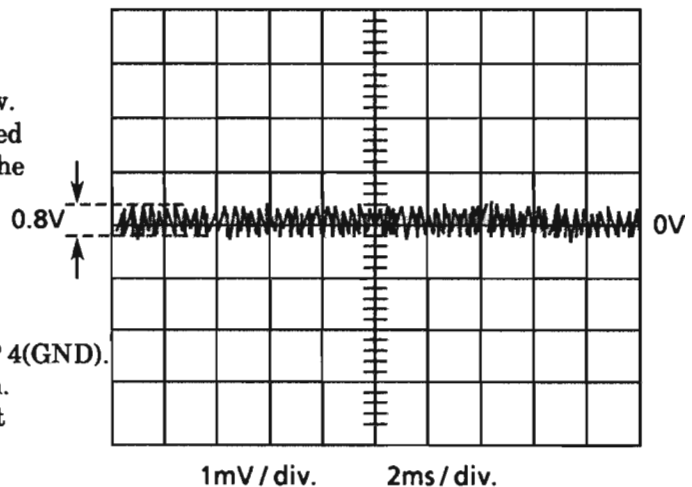

Figure 3

Deck section

1. Measuring instruments

Audio frequency signal generator (0dbs output at the 600 ohm output terminal from 50Hz to 20KHz)

Electronic voltmeter

Frequency counter

Wow & Flutter meter

Distortion Meter with band pass filter

Attenuator (600 ohm impedance)

A resistor with 600Ω

Standard Tape

0dbs = 0.775V

Tape No.	Frequency	Level (Wow & Flutter)	Purpose
VTT-703L	10kHz	- 10dBs	Head azimuth , Frequency Response
VTT-712	3000Hz	0dBs 0.025%WRMS	Tape Speed , Wow & Flutter
VTT-724	1kHz	- 4dBs	Standard Level
TMT-6447	-	-	Blunk Skip
TMT-6247 , TMT-6237	-	-	Music Scan
TS-8	-	-	Recording standard Normal : UR
TS-11	-	-	Recording standard METAL : MA
TS-10	-	-	Recording standard CrO ₂ : SA
GTG-N (CT-100M)	-	-	Forward /reverse play torque measuring
TW-2231	-	-	Feed forward /rewind torque measuring
C-120 Tape	-	-	Comfirming the tape running

2. Adjustment and repairing the mechanism

Item	Adjustment method	Standard value	Remarks
Head azimuth	<p>Deck A</p> <ol style="list-style-type: none"> 1. Connect an electronic voltmeter to the DOLBY TP (figure 1) to playback VTT-703L. 2. Adjust screw ① so that the indication of the voltmeter becomes maximum when PLAY (▶) is pressed. 3. Adjust screw ② so that the indication of the voltmeter becomes maximum when PLAY (◀) is pressed. <p>Deck B</p> <ol style="list-style-type: none"> 4. Adjust screw ③ so that the indication of the voltmeter becomes maximum when PLAY (▶) is pressed. 5. Adjust screw ④ so that the indication of the voltmeter becomes maximum when PLAY (◀) is pressed. 6. After making the adjustment, apply screw lock to prevent screws ①, ②, ③ and ④ coming loose. 	Maximum	<ol style="list-style-type: none"> 1. Refer to figure 1. 2. When the specified characteristic cannot be obtained because of head wear, excessive magnetization, etc., replace the head assembly and adjust the head azimuth. Also, perform the electric adjustment. 3. When there is the difference of more than 3 ~ 4 dB between left and right output levels, replace the head assembly to avoid complaints.
Playback torque	1. Measure the torque in the playback mode by the torqu meter.	26 ~ 62 g-cm	When the standard torque cannot be obtained, replace the FR arm assembly or motor.
Fast forward torque	1. Measure the torque in the fast forward mode by the torqu meter.	80 ~ 170 g-cm	When the standard torque cannot be obtained, replace the FR arm assembly or motor.
Wow & flutter	<ol style="list-style-type: none"> 1. Connect the wow & flutter meter to the DOLBY TP (figure 1) and play back VTT-712. 2. Its reading should be within 0.2% (WRMS). 	Less than 0.2%	As a complaint may occur if the wow & flutter fluctuates by 0.1% even though it is allowed in the standard, repairing is required.
Auto stop	Confirm that "AUTO STOP" works at the end of the tape and doesn't work tape is running.		

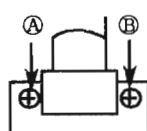

Deck A

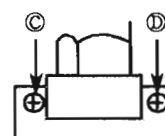

Deck B

Figure 3

3. Electrical Adjustments (Make the following adjustments after adjusting the head azimuth.)

In principle, the adjustments should be made in the following sequence.

Set the NR switch to OFF and the BEAT CUT switch to "1".

Adjustments marked with an asterisk (*) should always be made after the head is replaced

0dBs = 0.775V

Item	Adjustment Method	Adjustment Location	Standard Value	Remarks
1 Tape Speed	1. Connect a frequency counter to the DOLBY TP (figure 1) and play back VTT-712. 2. Normal speed Adjustment 1) Mechanism B Play back deck B to adjust the semi-fixed resistor R948. 2) Mechanism A Play back deck A to confirm that the difference between deck A and deck B is within $\pm 51\text{Hz}$. 3. High-speed adjustment 1) Mechanism B Play back deck B, check 6000Hz.	R948	3,000 Hz $\pm 10\text{Hz}$ 6,000Hz $\pm 600\text{Hz}$	1) Adjust the normal speed first, and perform the high speed adjustment.
* 2 Standard level (Playback Level)	1. Connect an electronic voltmeter to the DOLBY TP (figure 1). Play back VTT-724 (1 kHz : -4dBs) to adjust the semi-fixed resistors.	Deck A L: R221 R: R222 Deck B L: R389 R: R390	-5.5dBs (411mV) $\pm 1\text{dB}$	1) The playback level varies when the head is replaced so should be adjusted. Use an electronic voltmeter with an impedance of 100 k Ω or more.
* 3 Playback Frequency Response	1. Connect an electronic voltmeter to the DOLBY TP (figure 1). 2. Play VTT-703L (10kHz : -10dBs) and adjust semi-fixed resistors to obtain the standard values.	Deck A L: R203 R: R204 Deck B L: R205 R: R206	-11.5dBs (206mV) $\pm 3\text{dB}$	—
* 4 Recording Bias Frequency	1. Connect a frequency counter to the BIAS TP (figure 1), and perform a recording to adjust bias frequency.	L335	100 kHz +10kHz -5kHz	—
* 5 Record / Play Frequency Response (Bias current)	1. Supply 1kHz and 12.5kHz with 30mV signals to PHONO/AUX terminals respectively to record them. 2. Connect an electronic voltmeter to the DOLBY TP (figure 1) to confirm the recorded values. 3. If the values are not satisfied, adjust the semi-fixed resistors and record the signal again to confirm the recorded values.	L: R335 R: R336	$0 \pm 2\text{ dB}$ with 1 kHz as the standard.	Refer to figure 5 below. 1) The recording and playback frequency response of a cassette deck are adjusted by adjusting the bias. 2) Perform the adjustment with normal tape and confirm that the values are within the range for metal tape.

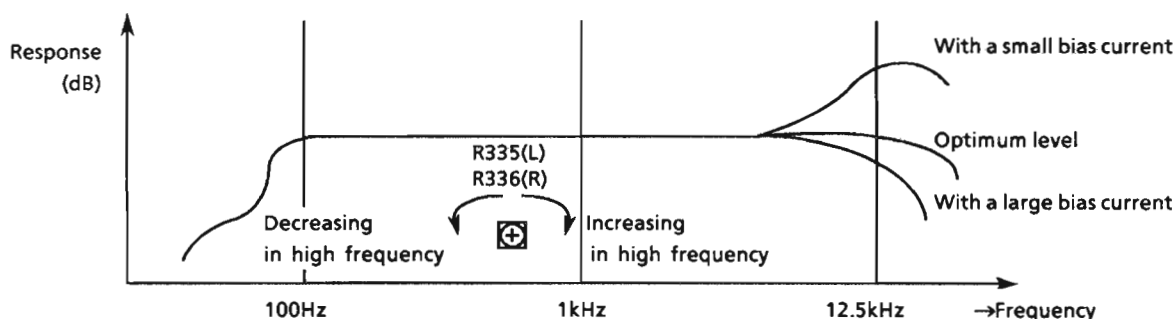
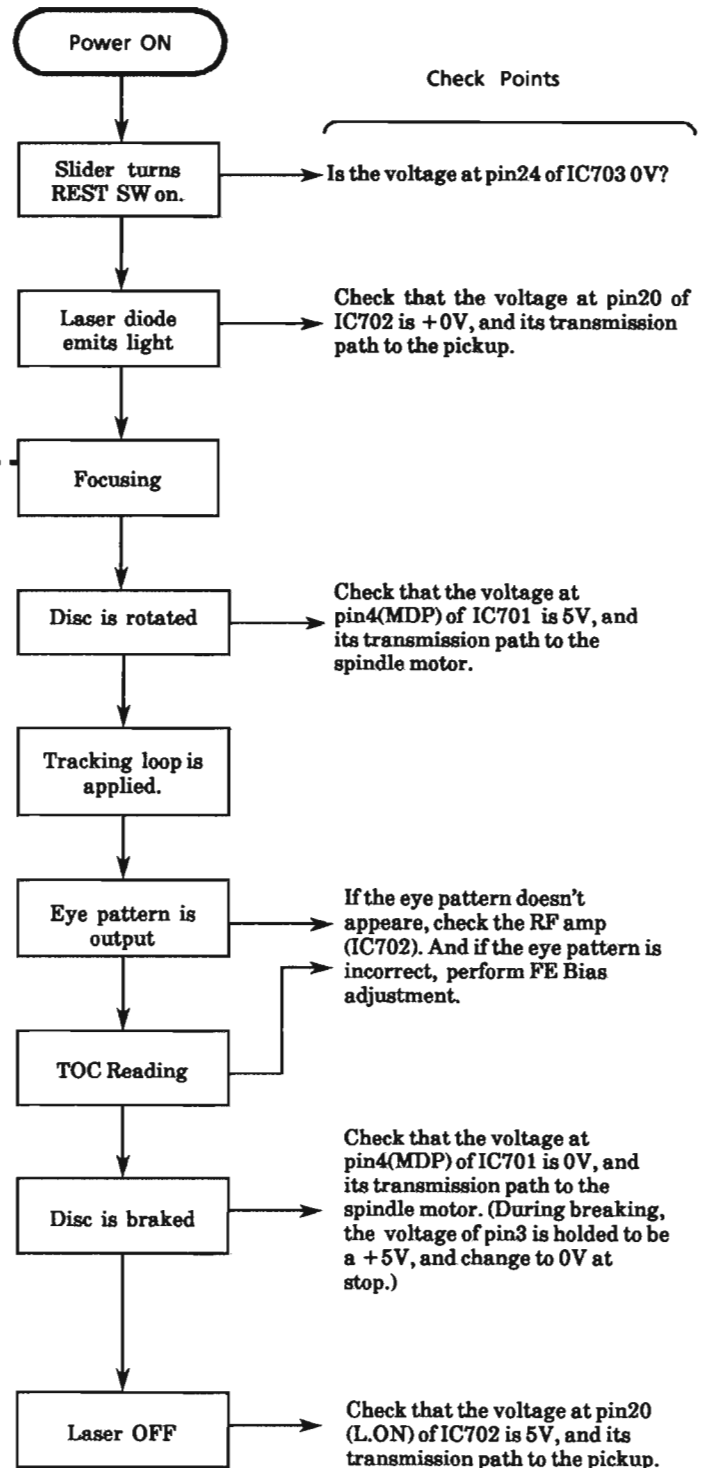
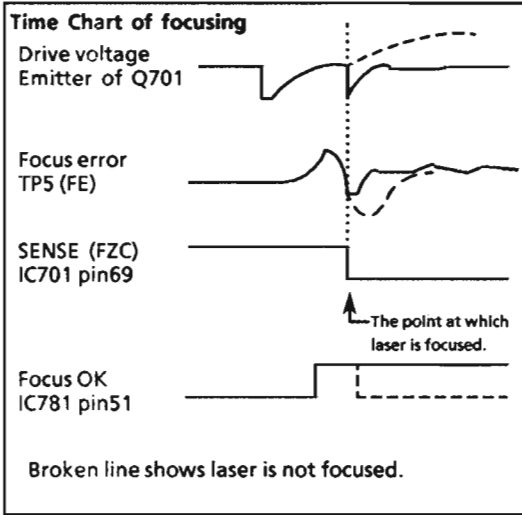

Figure 5

	Item	Adjustment Method	Adjustment Location	Standard Value	Remarks
*	6 Record / Playback Sensitivity	<ol style="list-style-type: none"> 1. Input a 1 kHz (- 8.2dBs: 300mV) signal to PHONO / AUX terminals and record it on the left and right channels . 2. Connect an electronic voltmeter to the DOLBY TP (figure 1) to confirm the recorded values . 3. If the values are not satisfied , adjust the semi-fixed resistors and record the signal again to confirm the recorded values. 	L : R367 R : R368	- 5.5dBs (411mV) ± 1dB	Adjust with normal tape and make sure that the left / right level difference is 1.0dB or less
	7 Erase ratio check	<ol style="list-style-type: none"> 1. Record a music source using the Metal tape. 2. Rewind and erase the recorded section. 3. Comfirm nothing can be heard. 	—	—	—
	8 Music Scan	<ol style="list-style-type: none"> 1. Make sure not to work the music scanning operation at the start of tape wind using TMT-6237. 2. Make sure to work the music scanning operation at the end of tape wind using TMT-6247. 	—	—	—

Flow of Functional Operation Until TOC is Read



Maintenance of Laser Pickup

(1) Life of the laser diode

When the life of the laser diode has expired, the following symptoms will appear.

1. The level of RF output (EFM output: amplitude of eye pattern) will be low.
2. The drive current required by the laser diode will be increased.

In such a case, check the life of the laser diode by the flowchart below

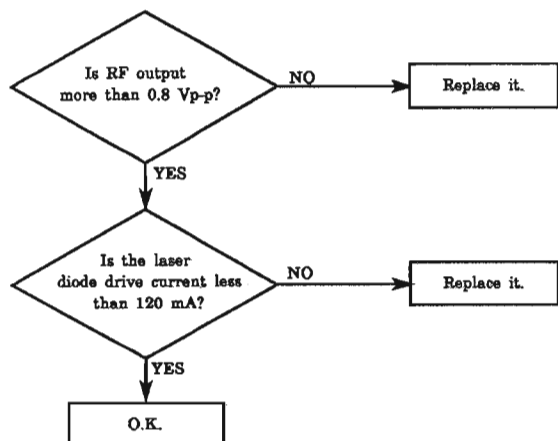

(2) Measurement of laser diode drive current

Measure the voltage across the resistor R671 by using a milli-voltmeter. When the voltage is more than 1.2V, it shows that the life of the laser diode has expired.

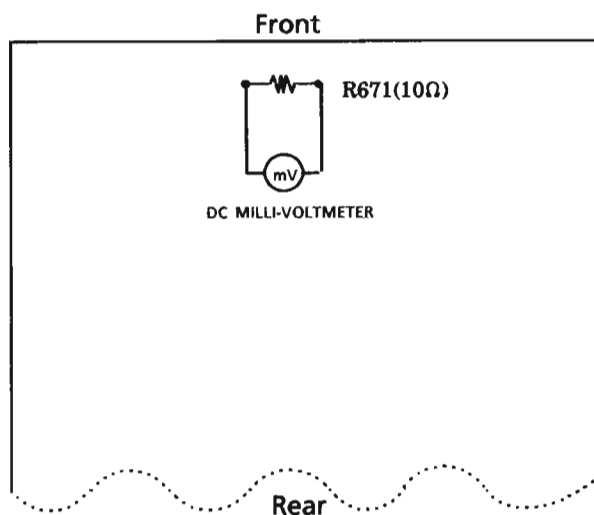

(3) Semi-fixed resistor on the APC PC board

The semi-fixed resistor on the APC printed circuit board which is attached to the pickup is used to adjust the laser power. Since this adjustment should be performed to match the characteristics of the whole optical block, do not touch the semi-fixed resistor.

If the laser power is lower than the specified value, the laser diode is almost worn out, and the laser pickup should be replaced.

If the semi-fixed resistor is adjusted while the pickup is functioning normally, the laser pickup may be damaged due to excessive current.

Replacement of Laser Pickup

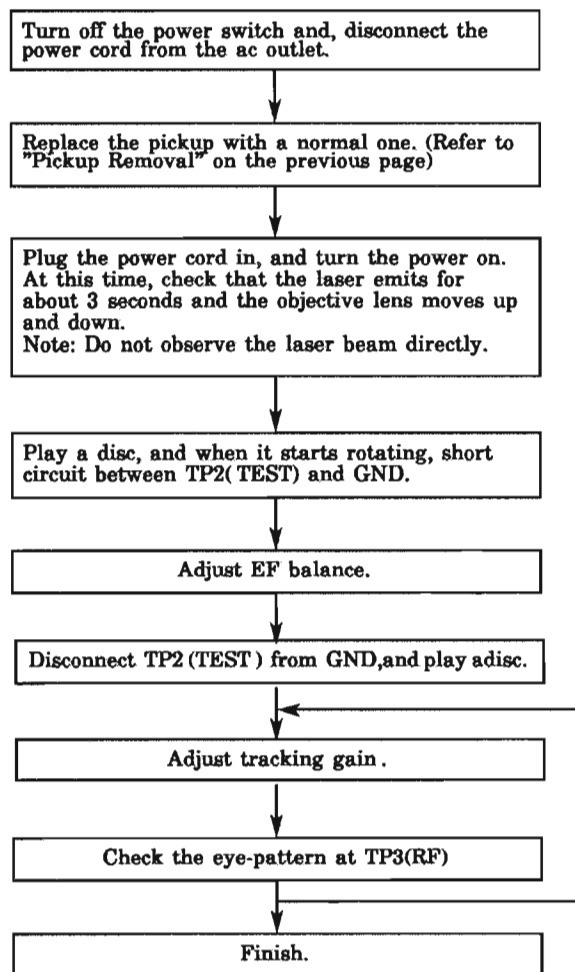

Note: Since one adjustment may affect other settings, repeat these adjustments a few times.

System Control & Audio Section

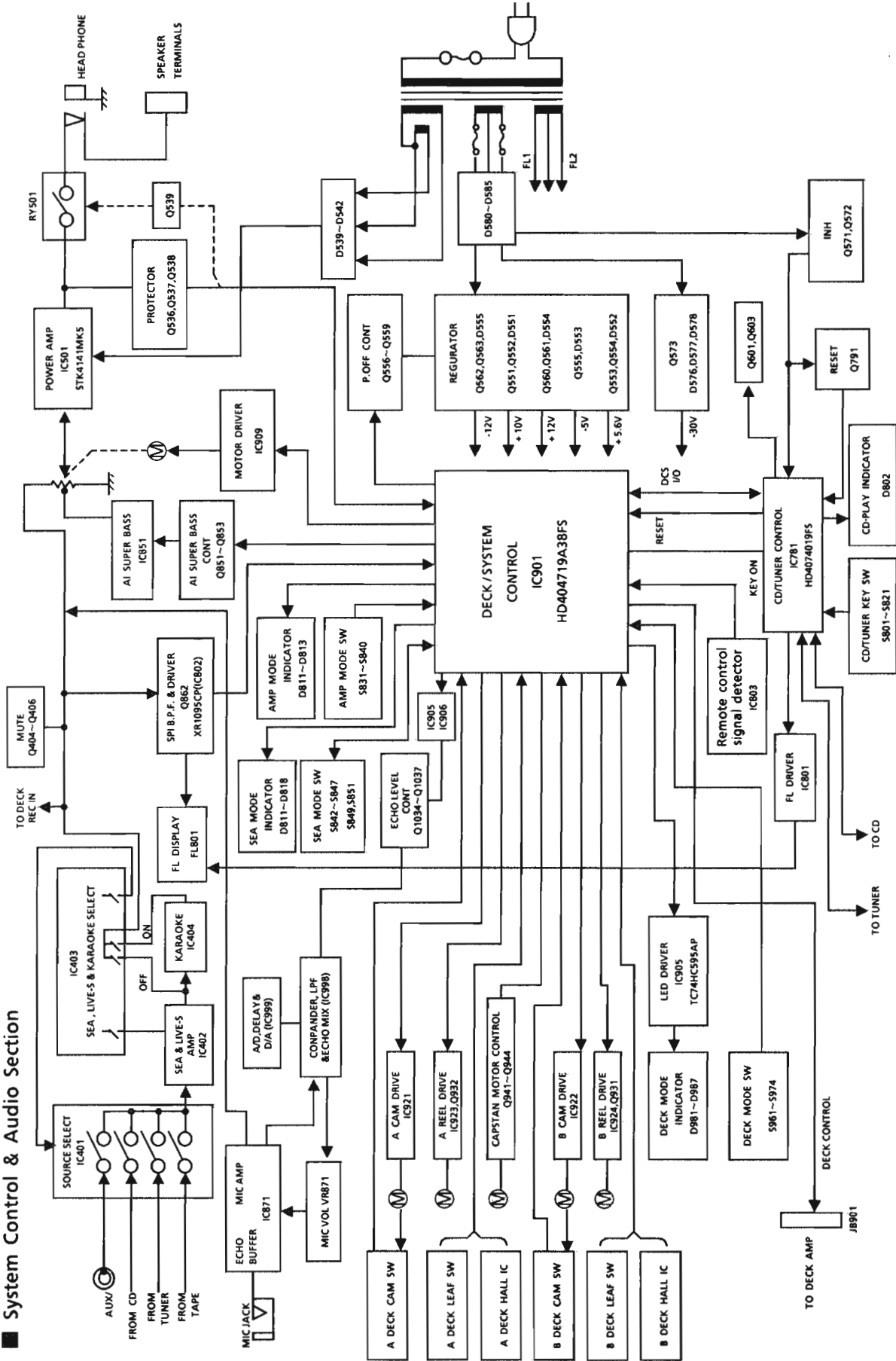

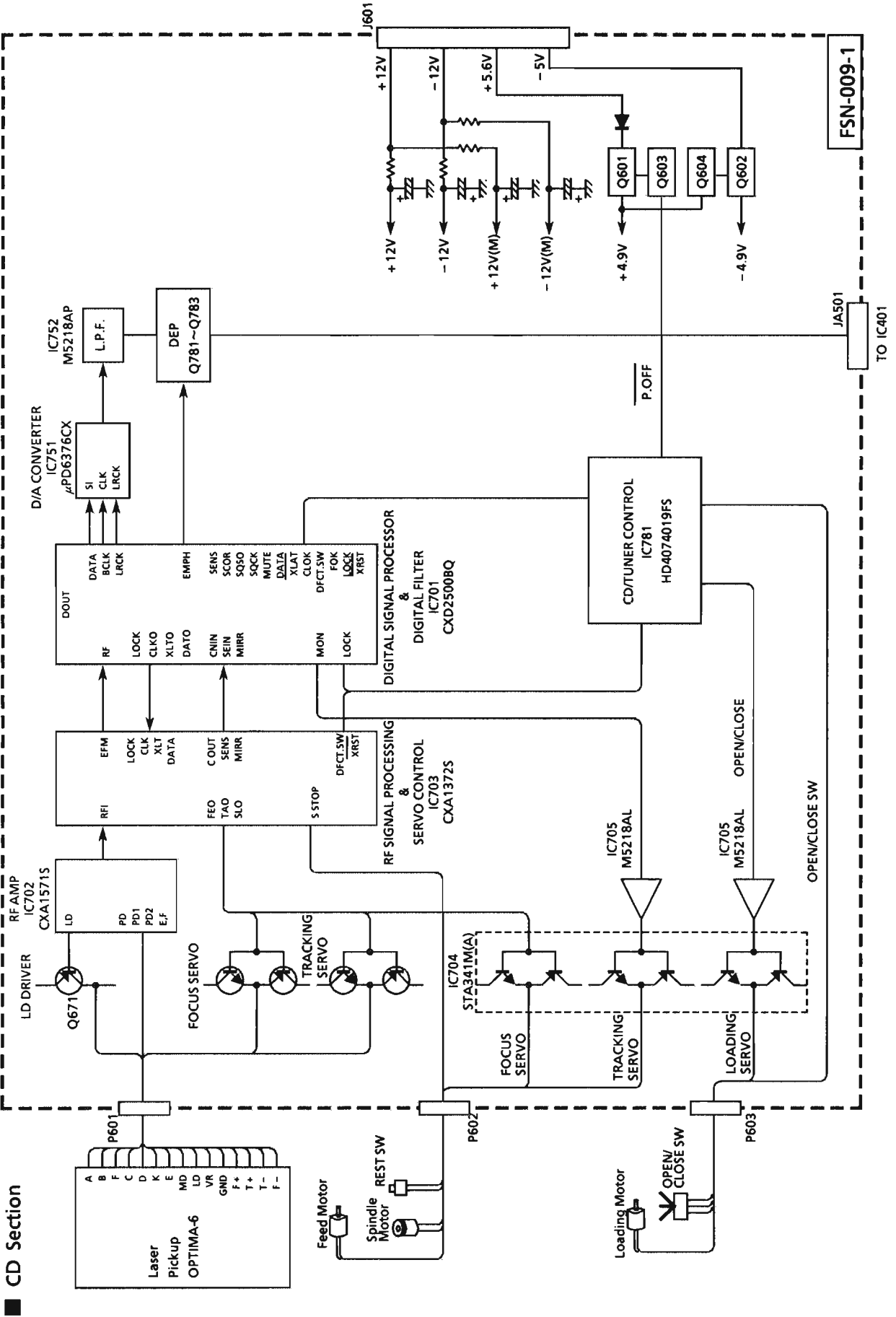

■ Tuner Section

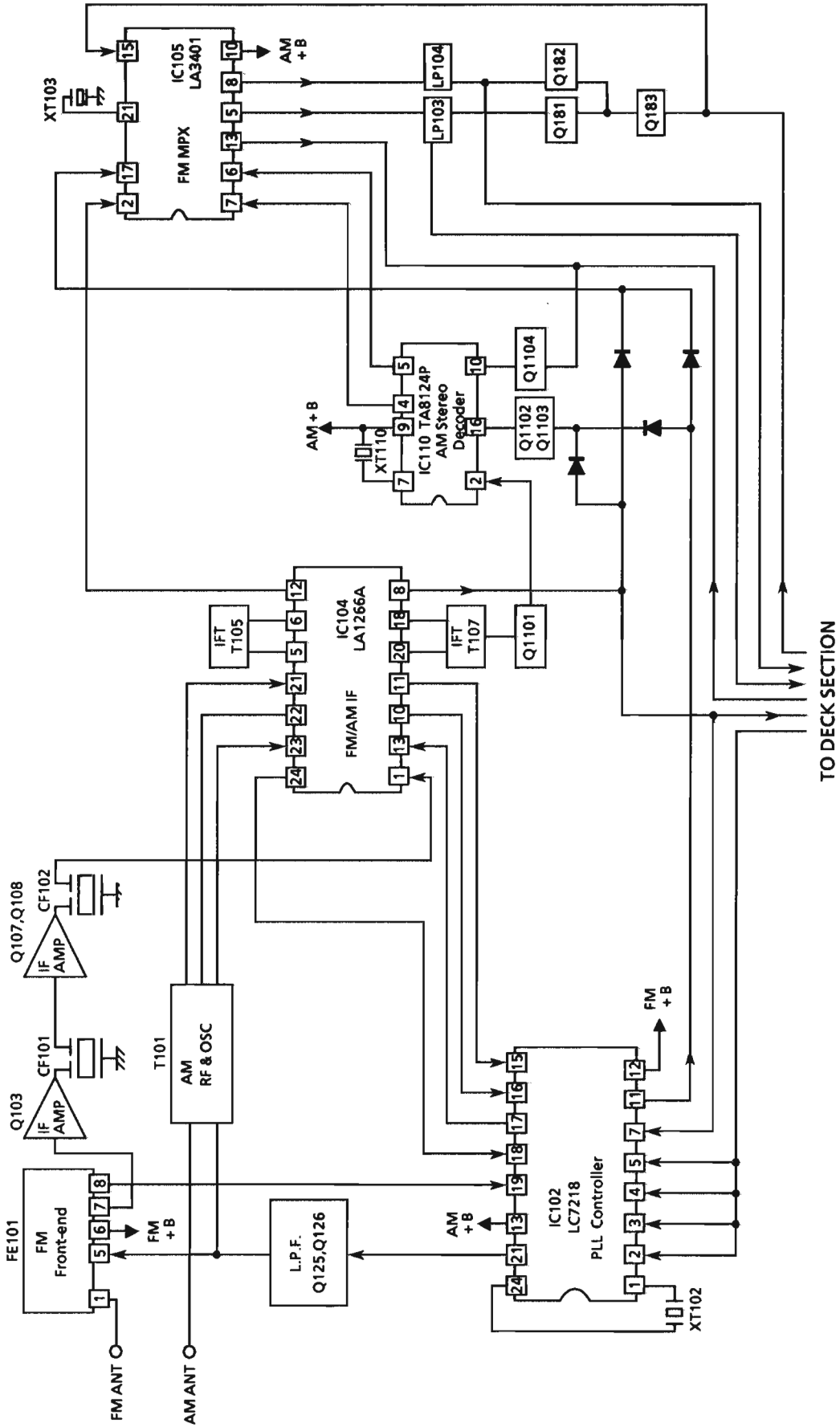

■ Cassette Deck Section

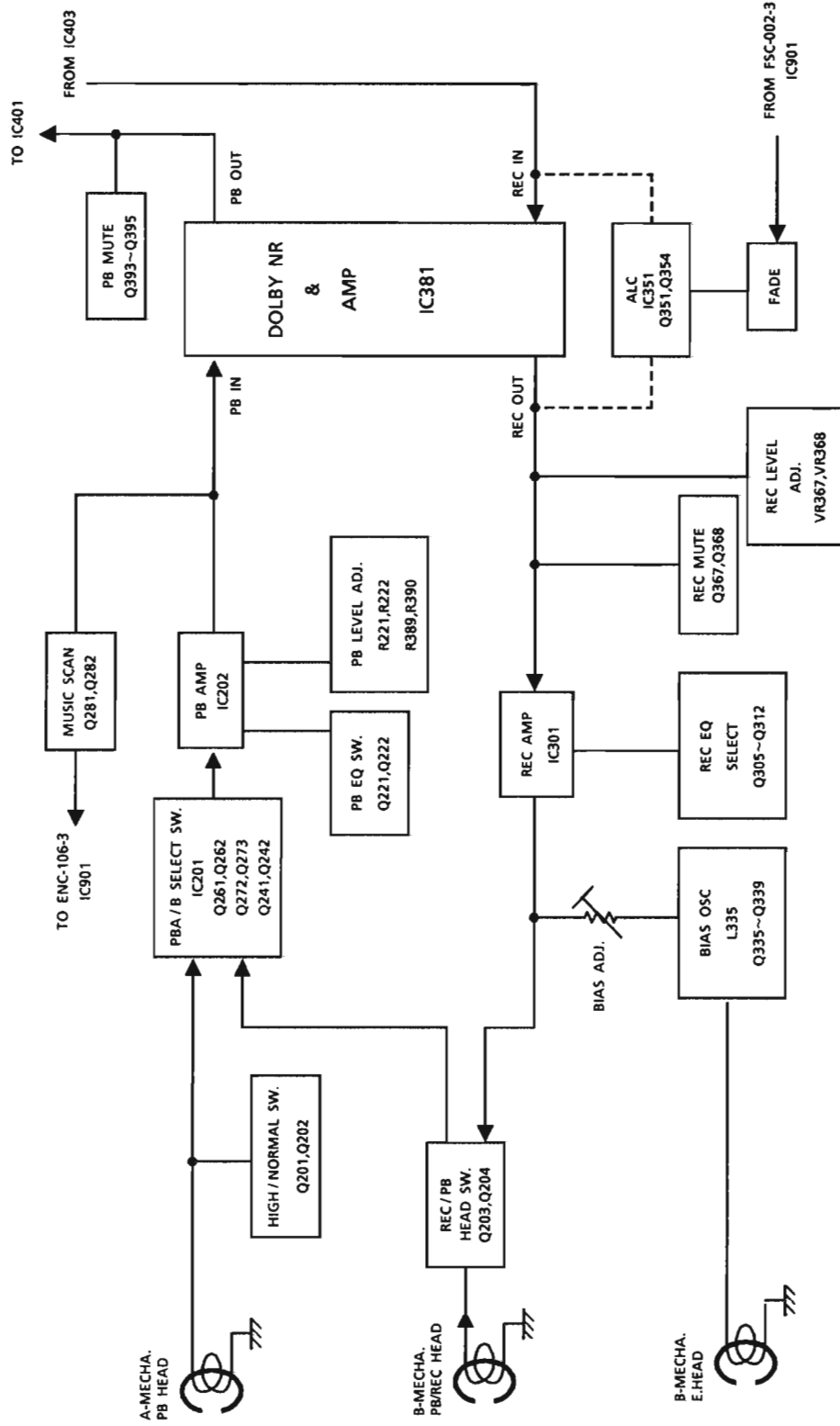

CA-S20BK

Application Points for Grease

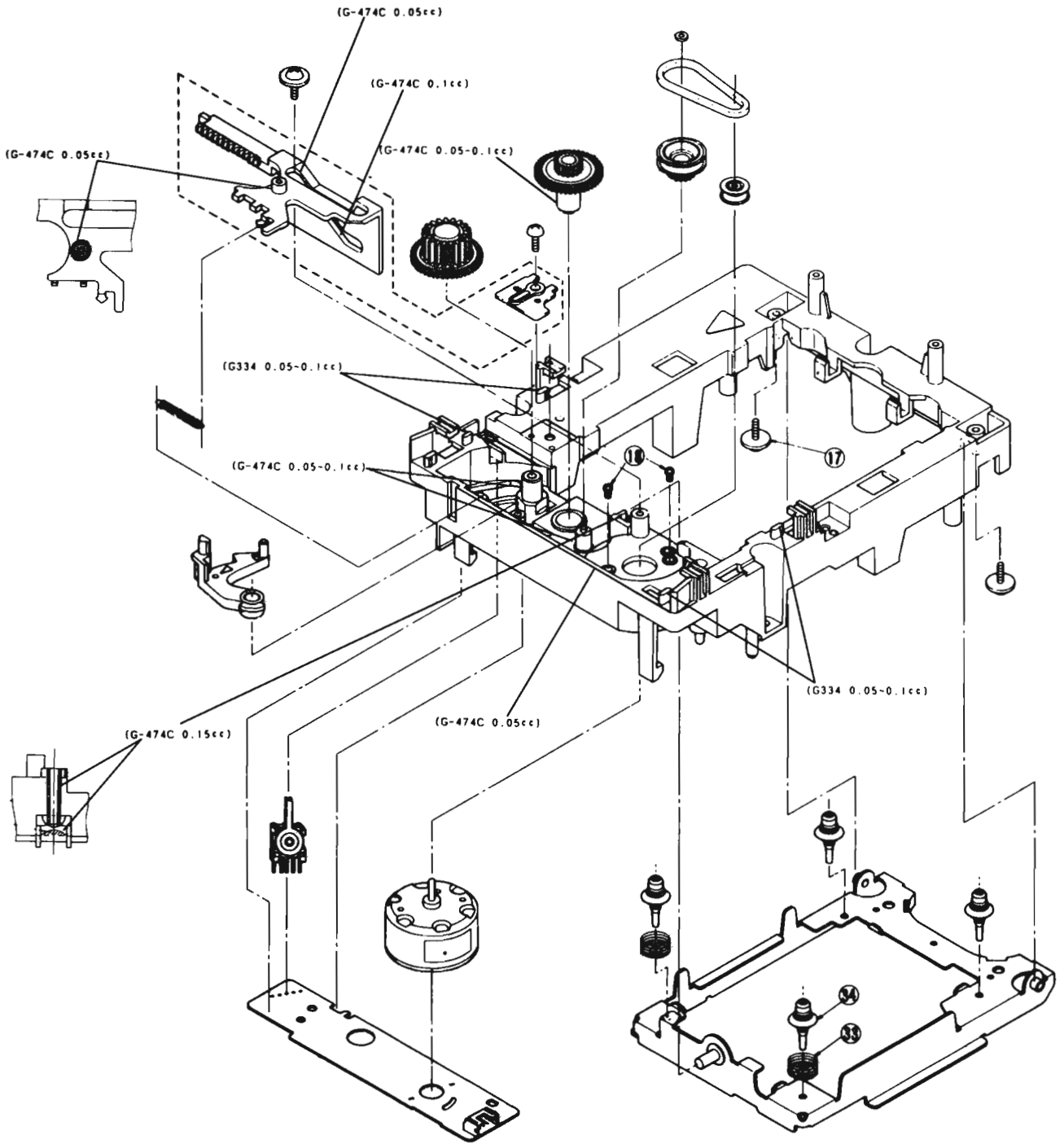

P.S-A.S-a

P.S-A.S-b

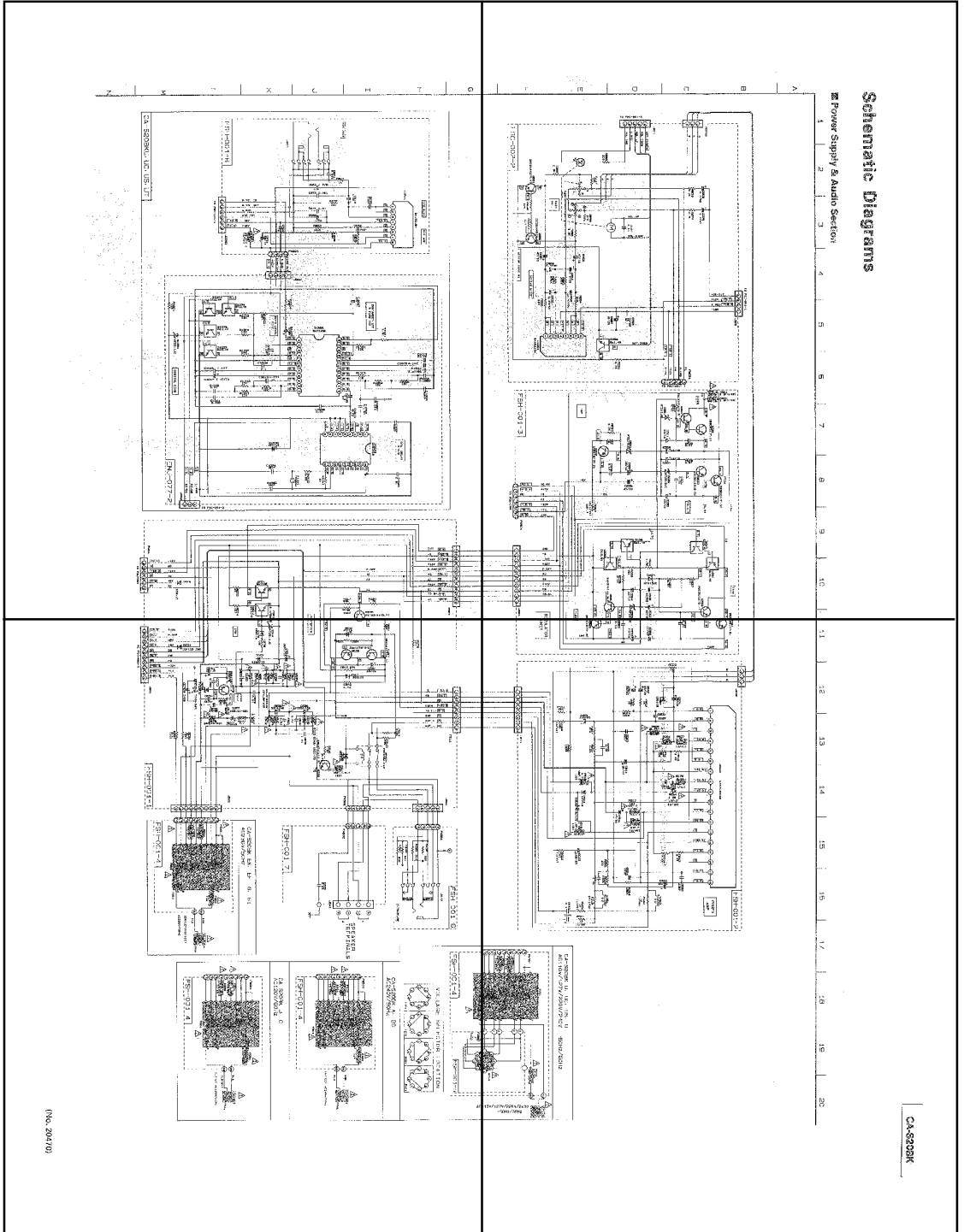

P.S-A.S-c

P.S-A.S-d

Z N L X C H I G

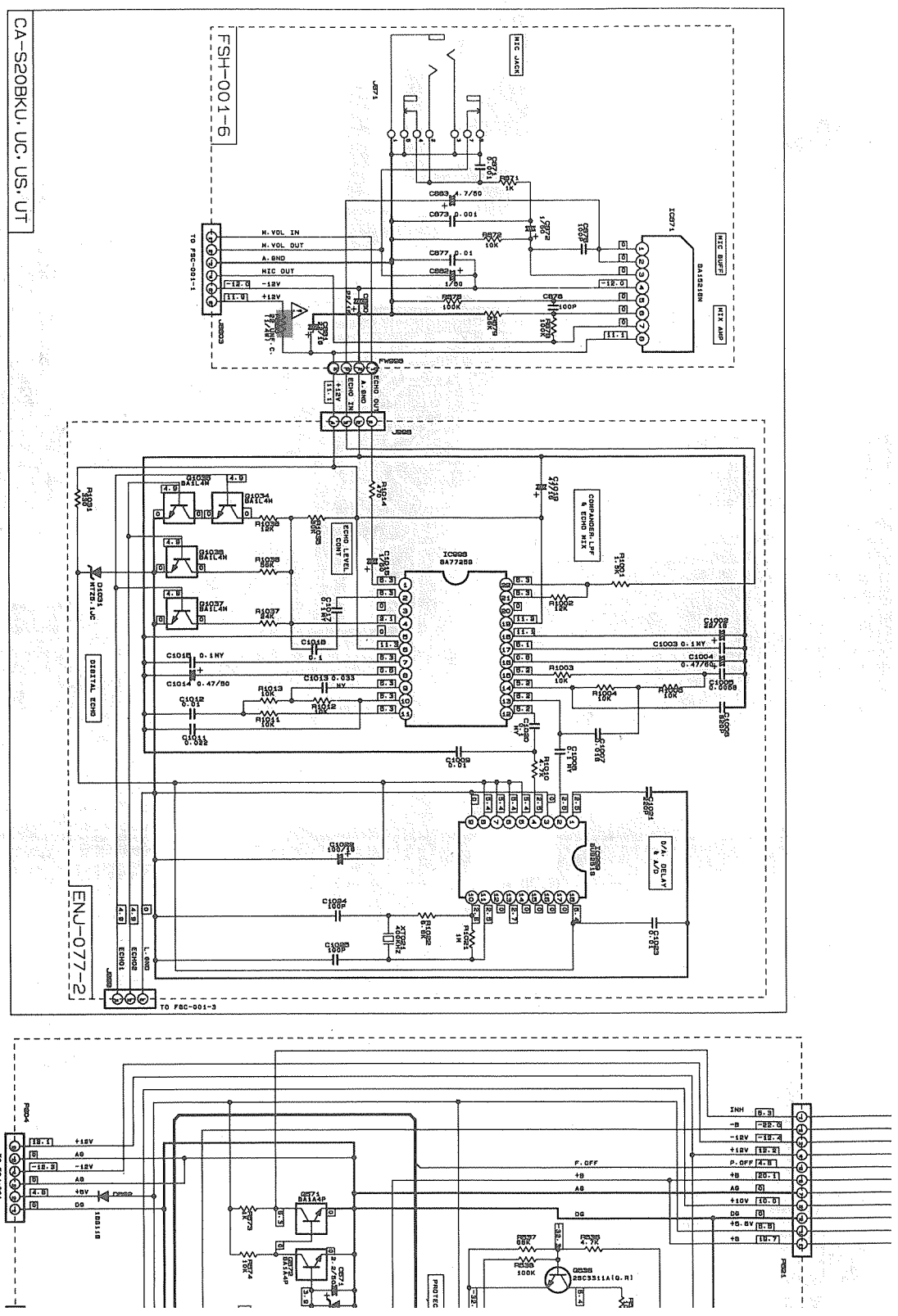

Schematic Diagrams

Power Supply & Audio Section

1 2 3 4 5 6 7 8 9 10

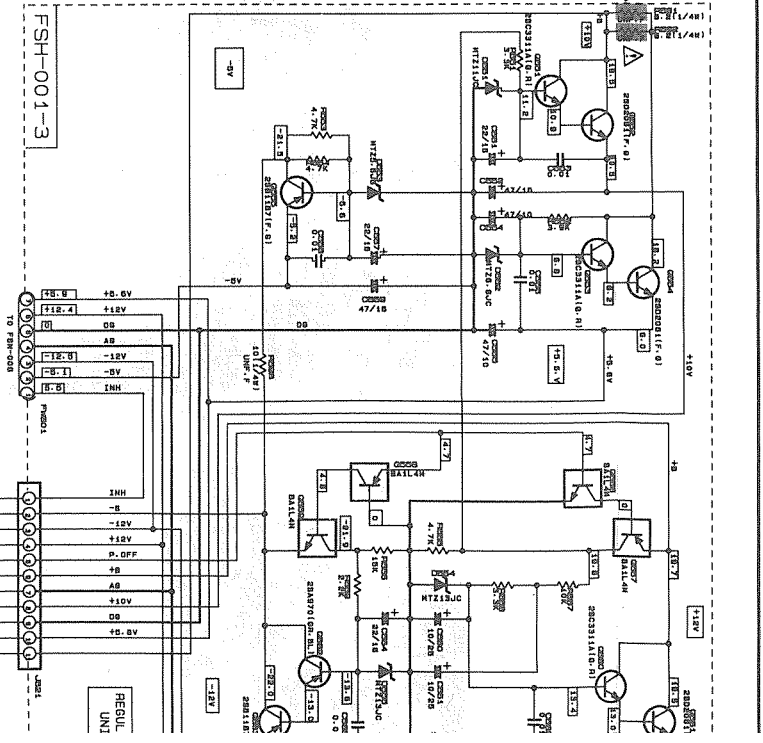
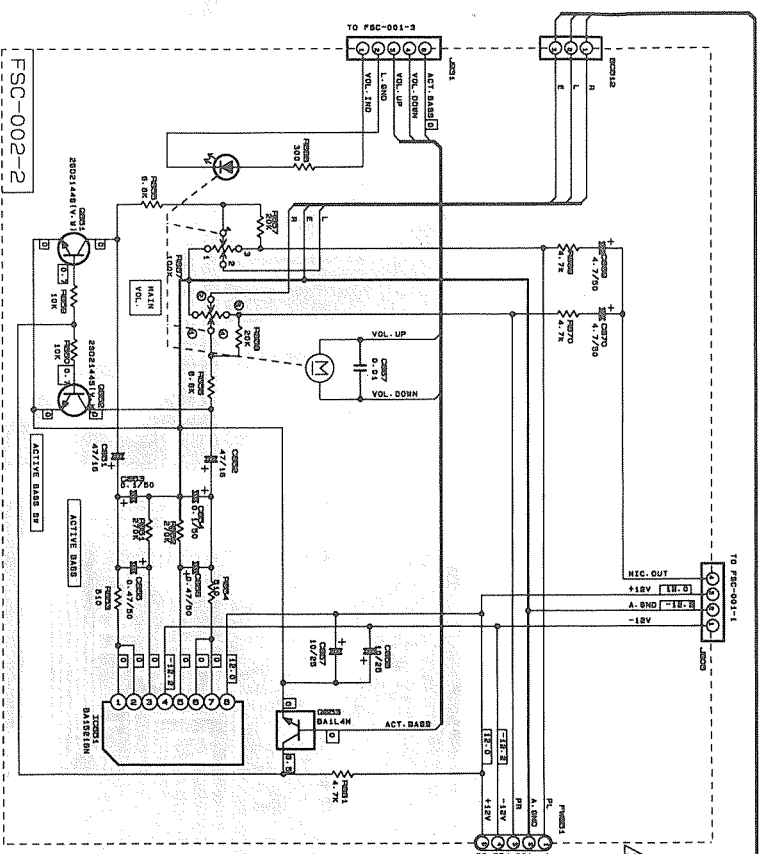

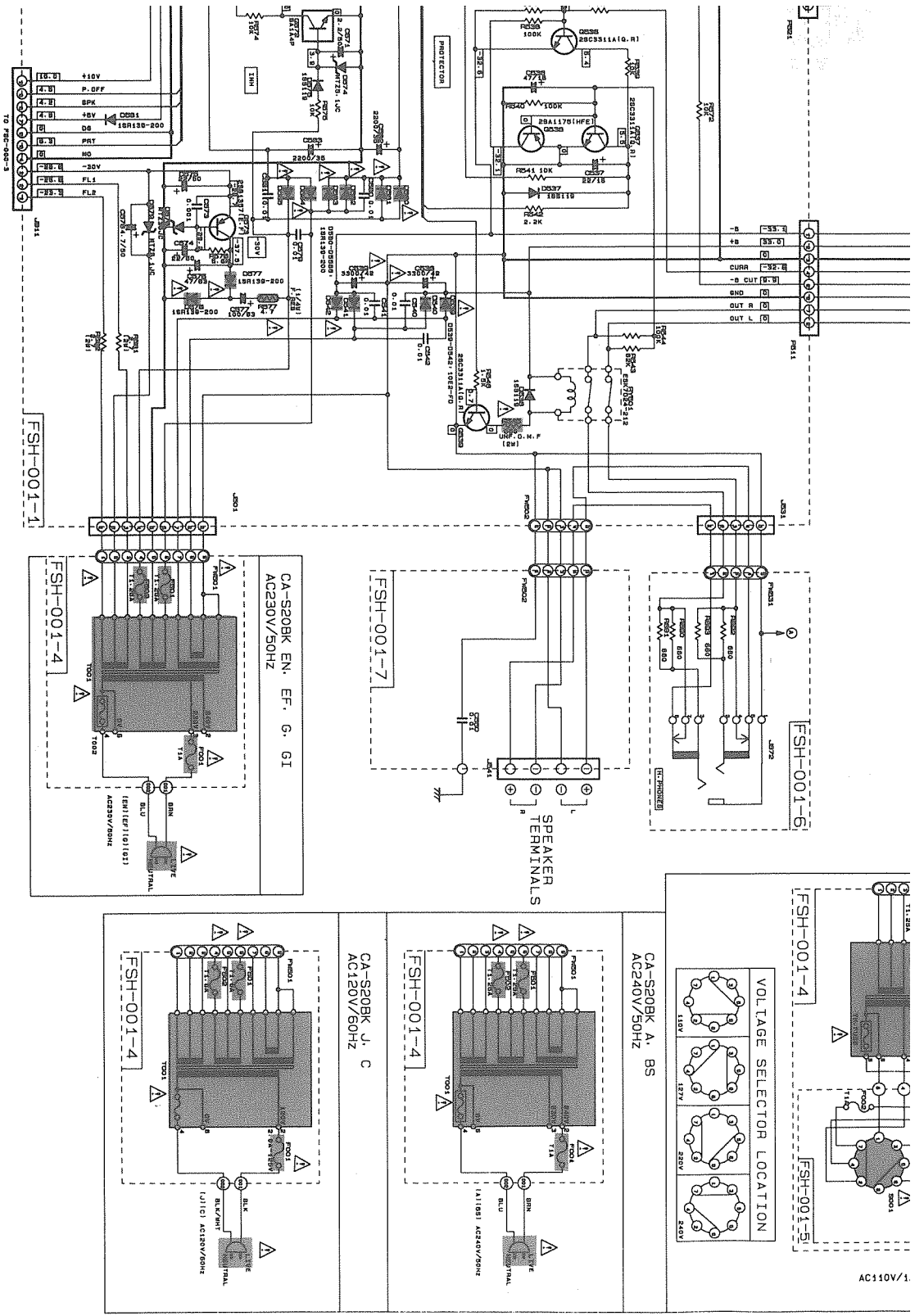

(NO. 20470)

CA-S20BK

11 12 13 14 15 16 17 18 19 20

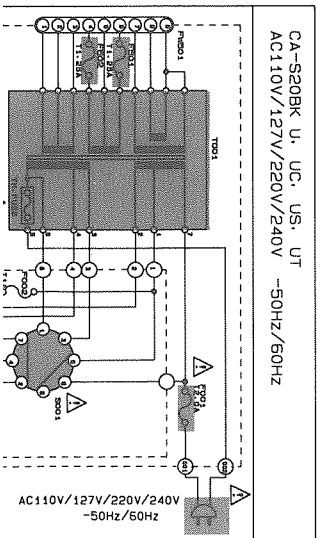
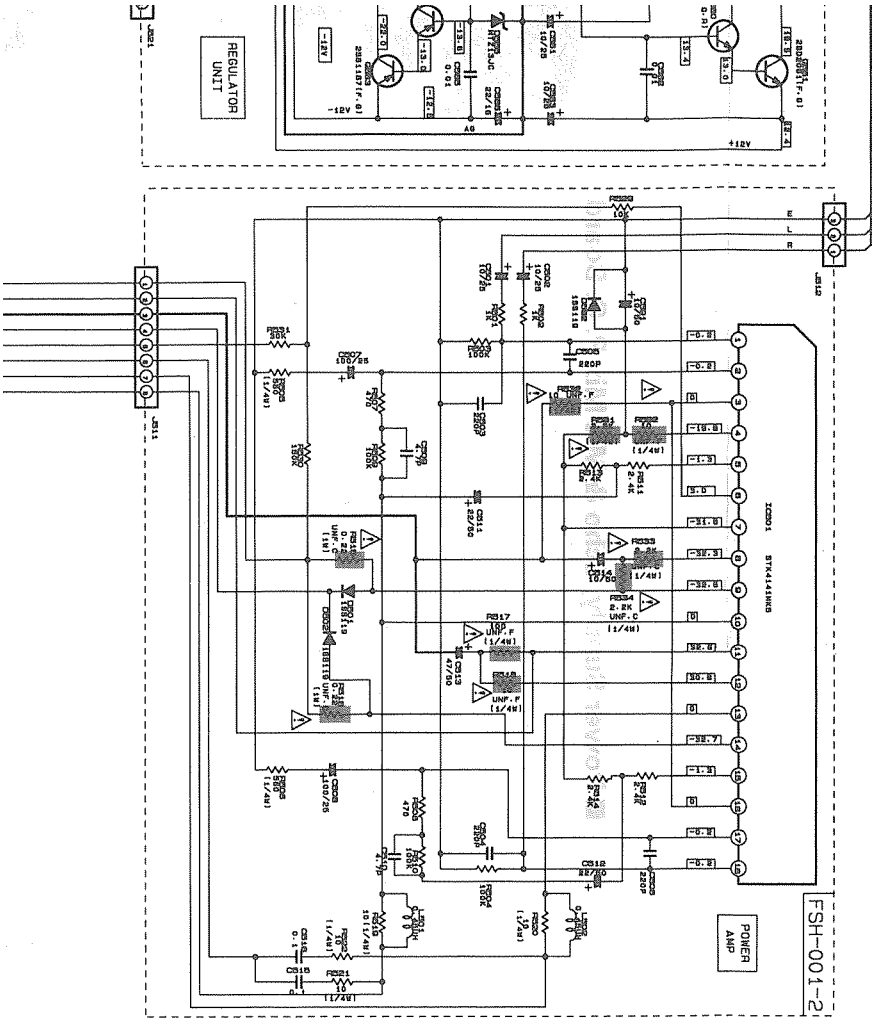

■ Power Supply, Echo & Mic Mix P. C. Board

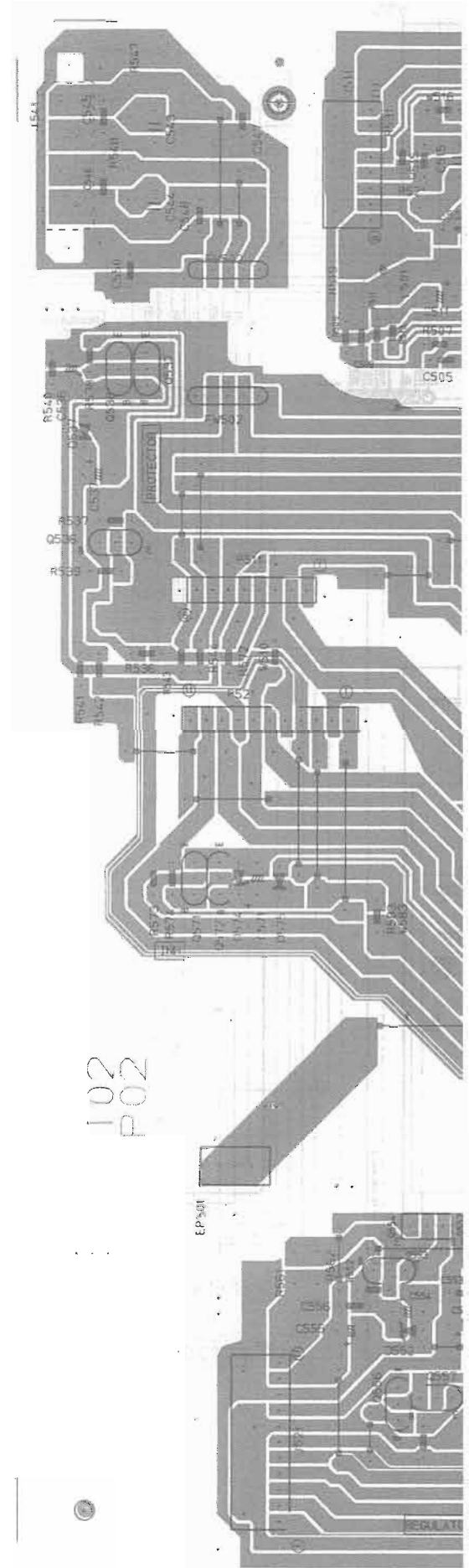

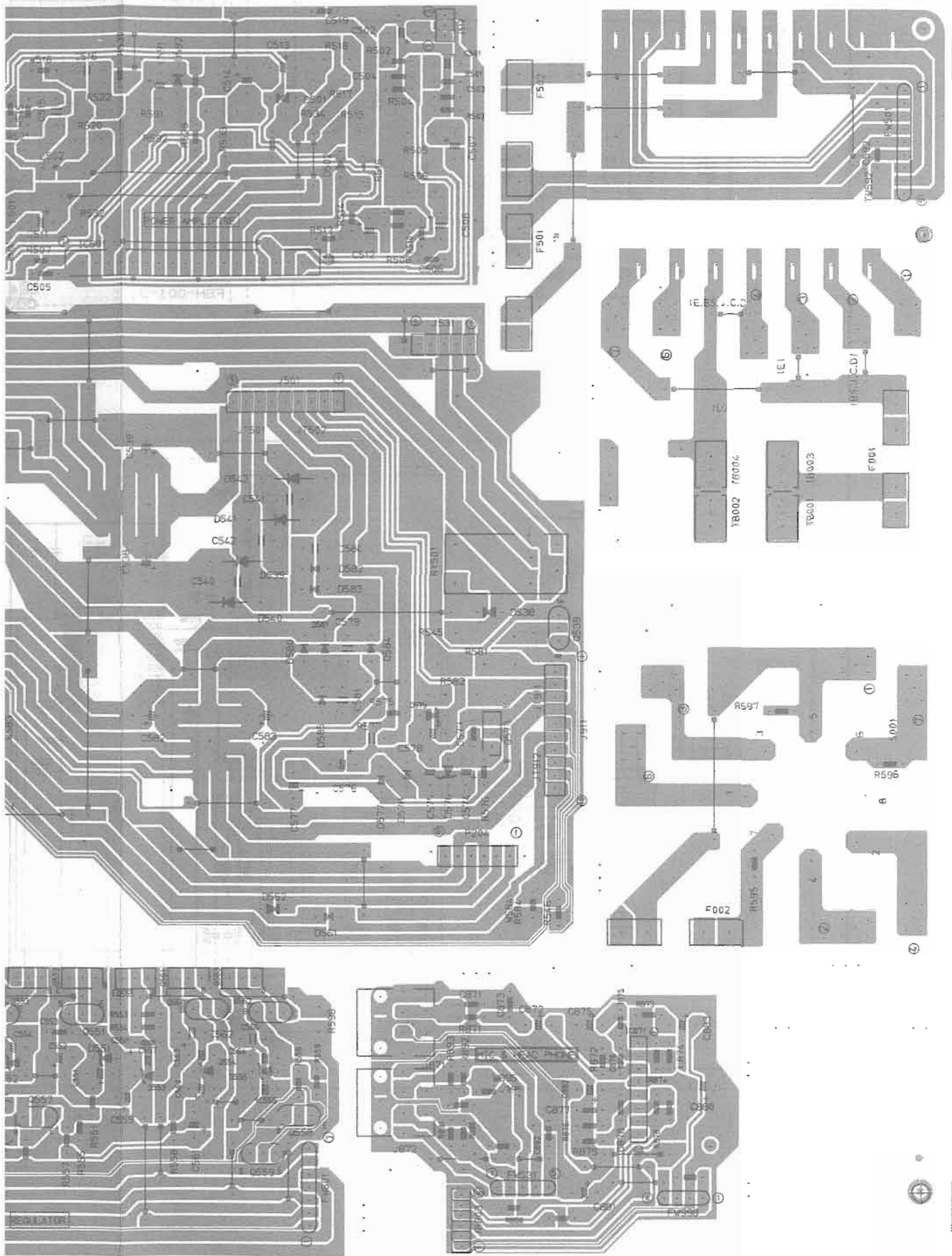

S.C.S-a

S.C.S-b

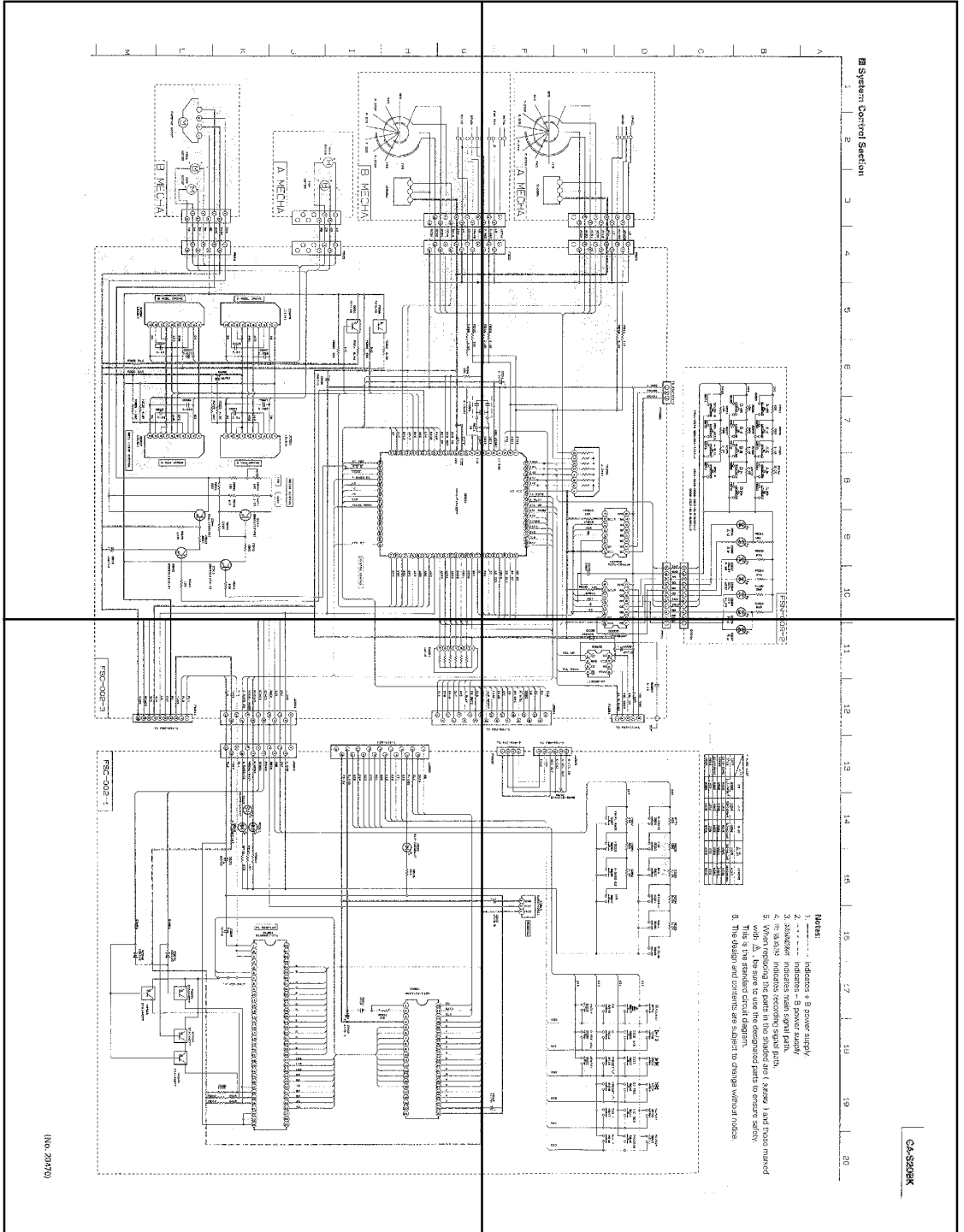

S.C.S-c

S.C.S-d

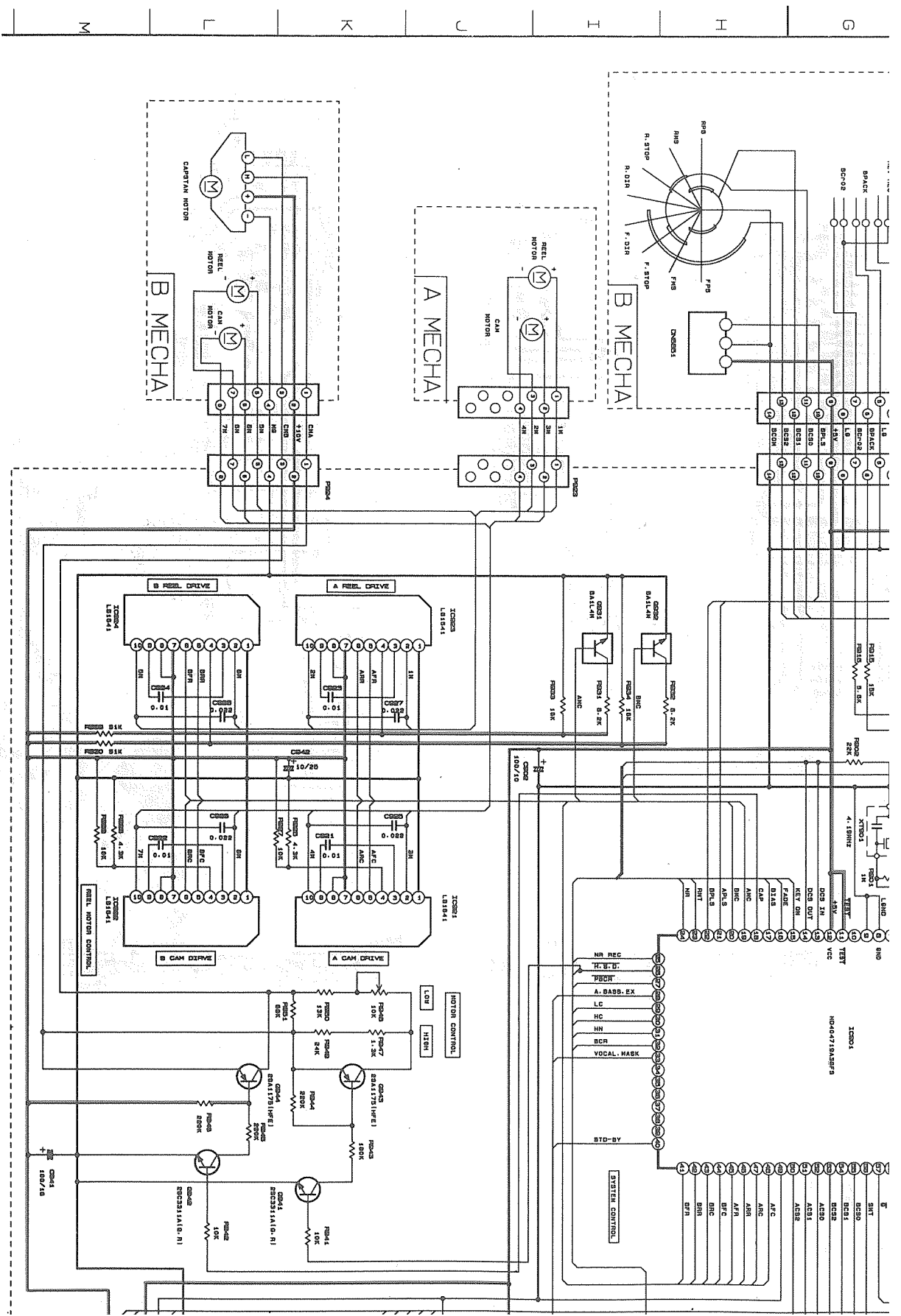

M L K J H I G

System Control Section

1 2 3 4 5 6 7 8 9 10

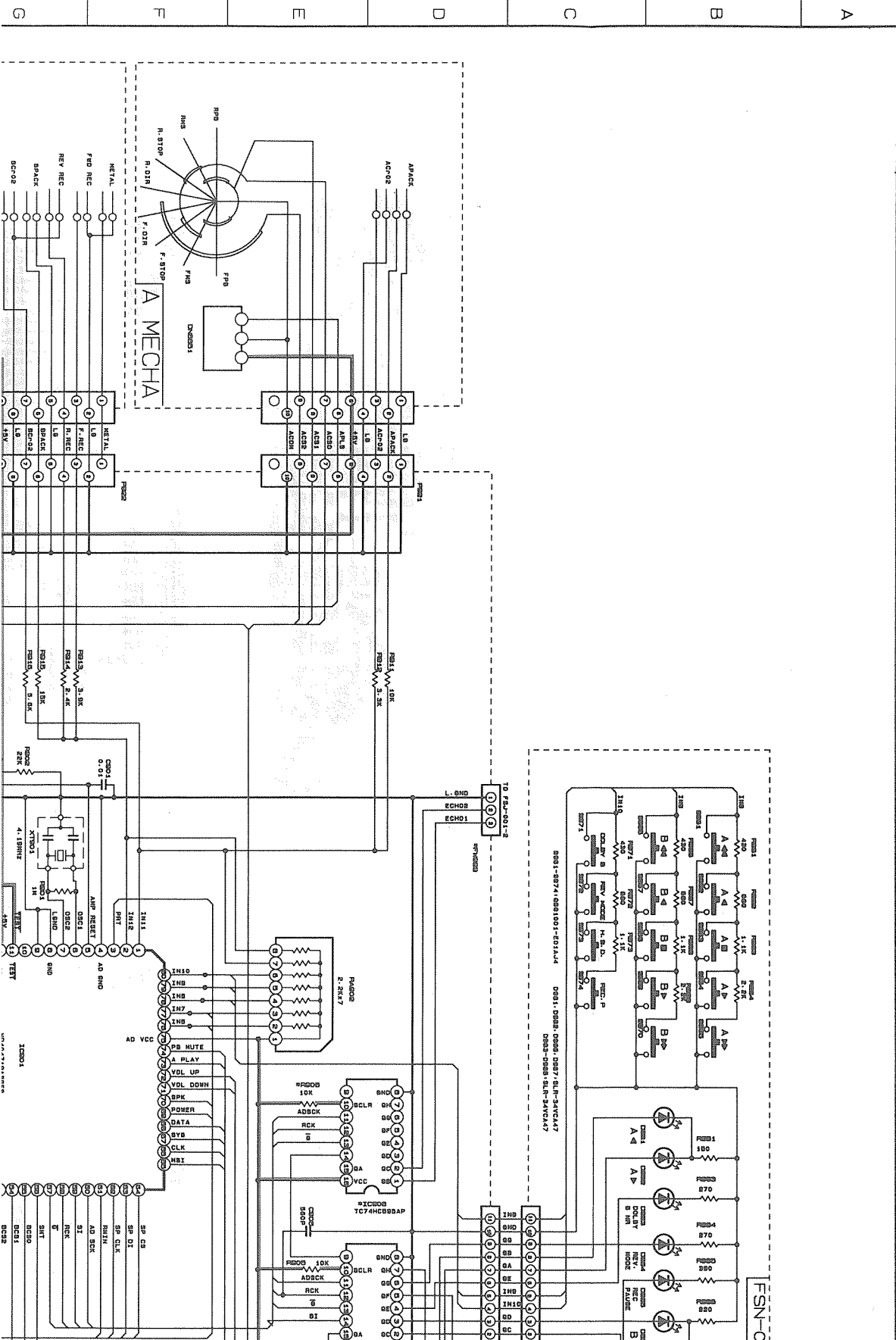

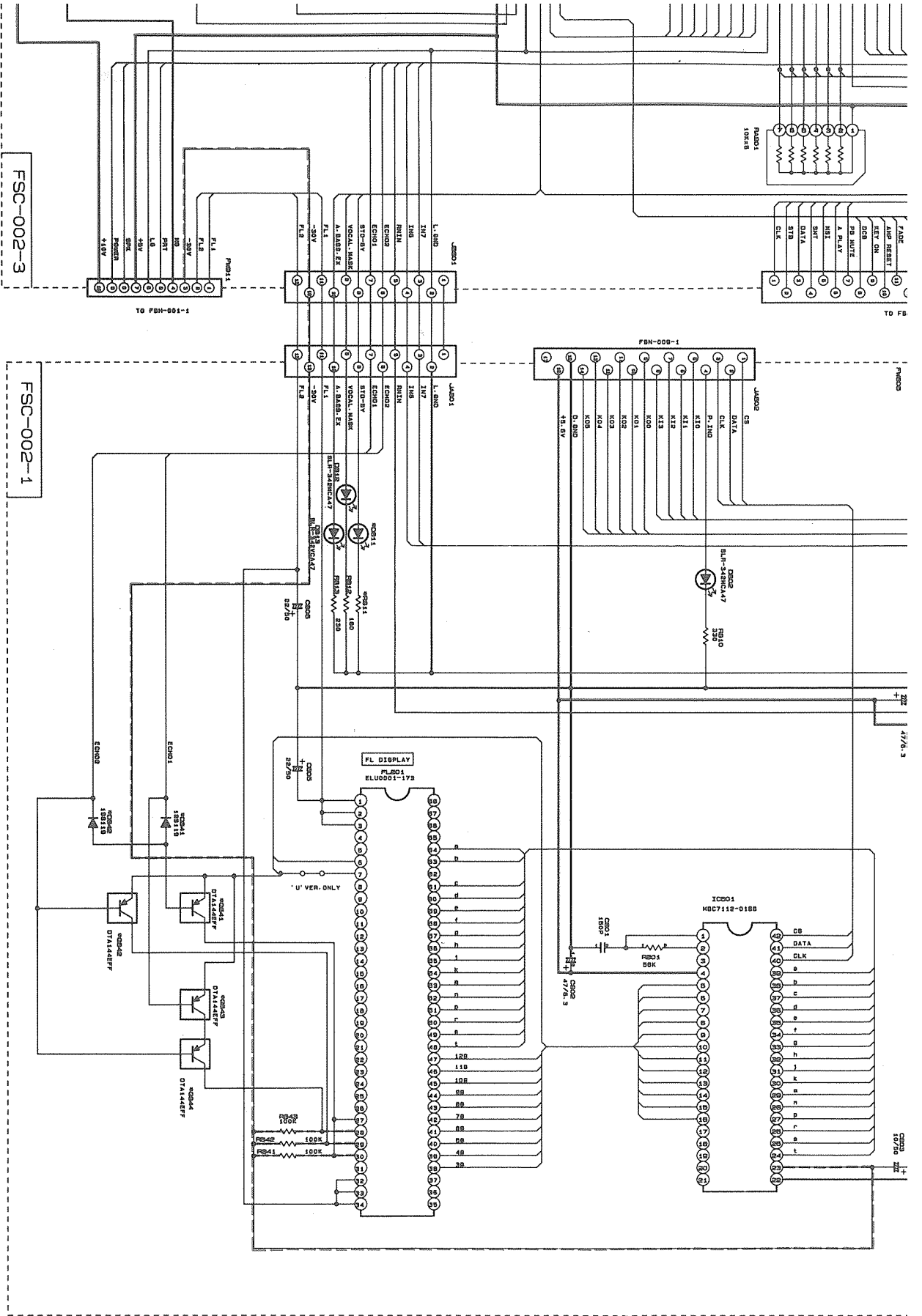

(NO. 20470)

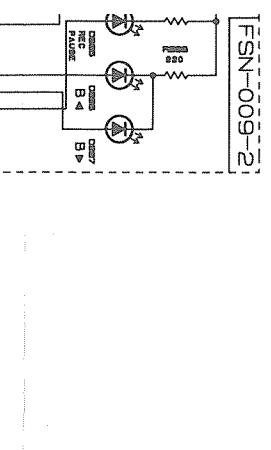

• MARK LIST

VEN	BS	J, C	U, UC	OTHER
CS07	NONE	NONE	USED	NONE
DS11	REPLACEMENT	REPLACEMENT	REPLACEMENT	REPLACEMENT
DS41-DS43	NONE	NONE	USED	NONE
TE000	NONE	NONE	USED	NONE
DS41-DS44	NONE	NONE	USED	NONE
RE000	NONE	NONE	USED	NONE

- Notes:**
1. _____ indicates + B power supply.
 2. _____ indicates - B power supply.
 3. _____ indicates main signal path.
 4. _____ indicates recording signal path.
 5. When replacing the parts in the shaded area () and those marked with Δ , be sure to use the designated parts to ensure safety. This is the standard circuit diagram.
 6. The design and contents are subject to change without notice.

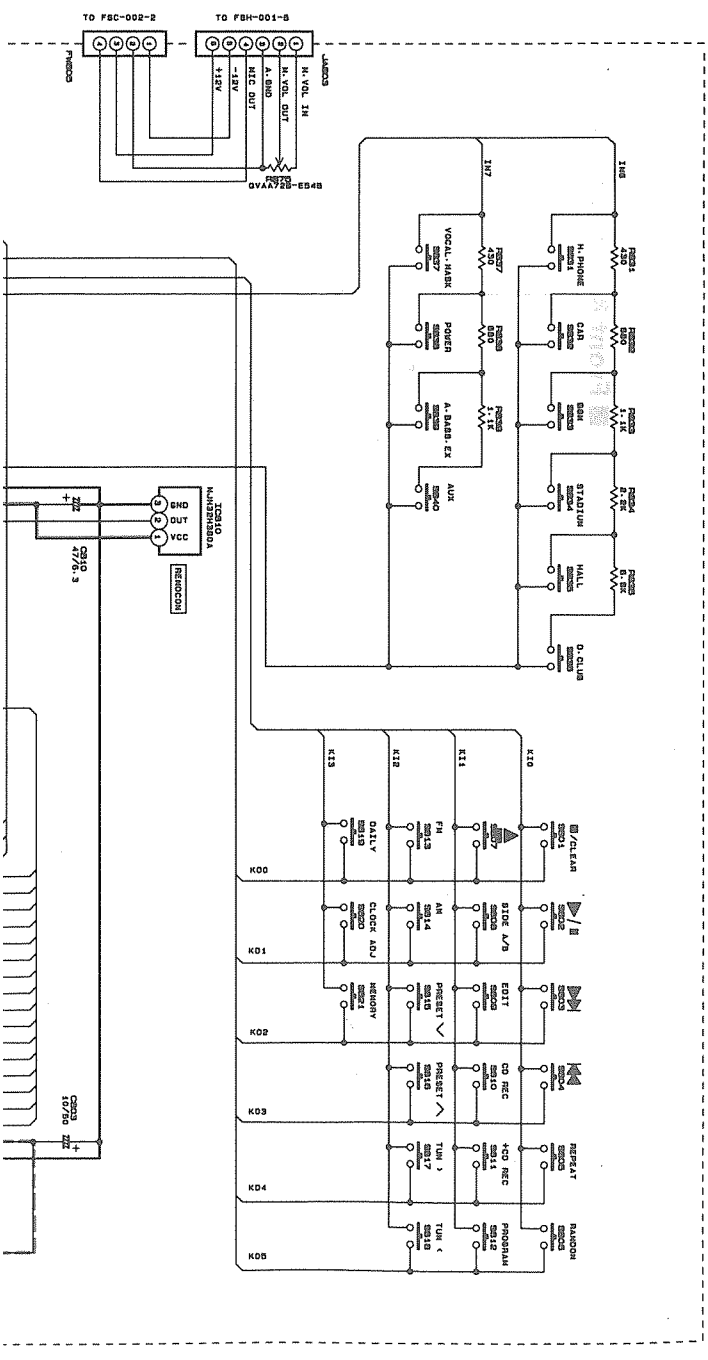
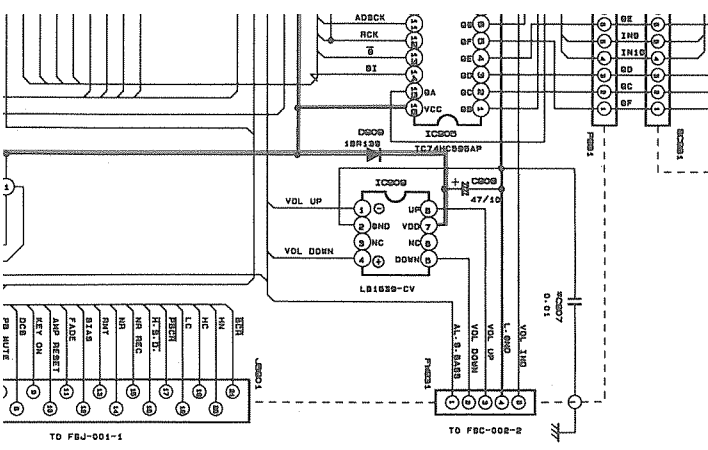

■ Front & Controller P. C. Board

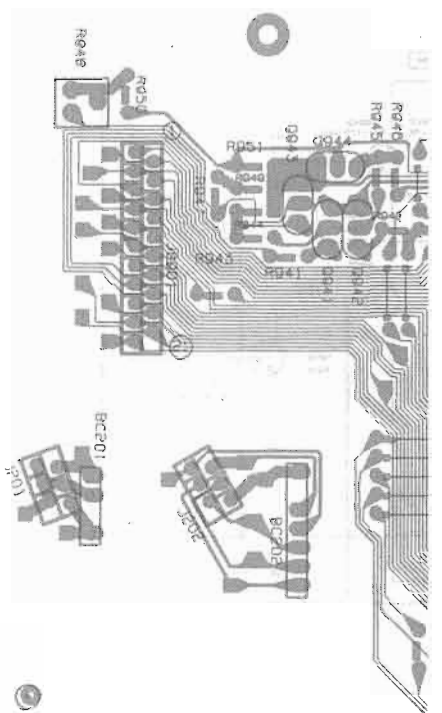
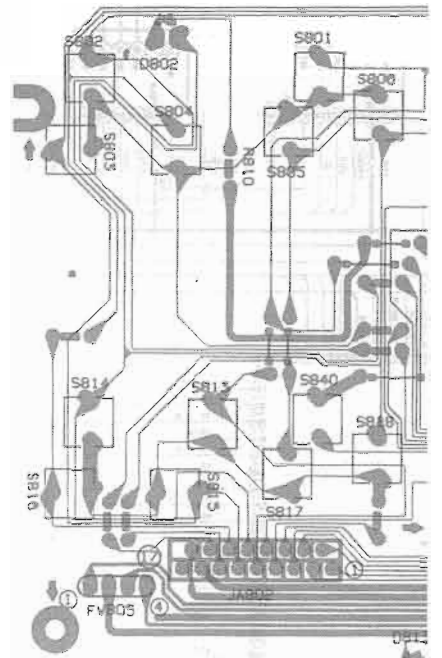

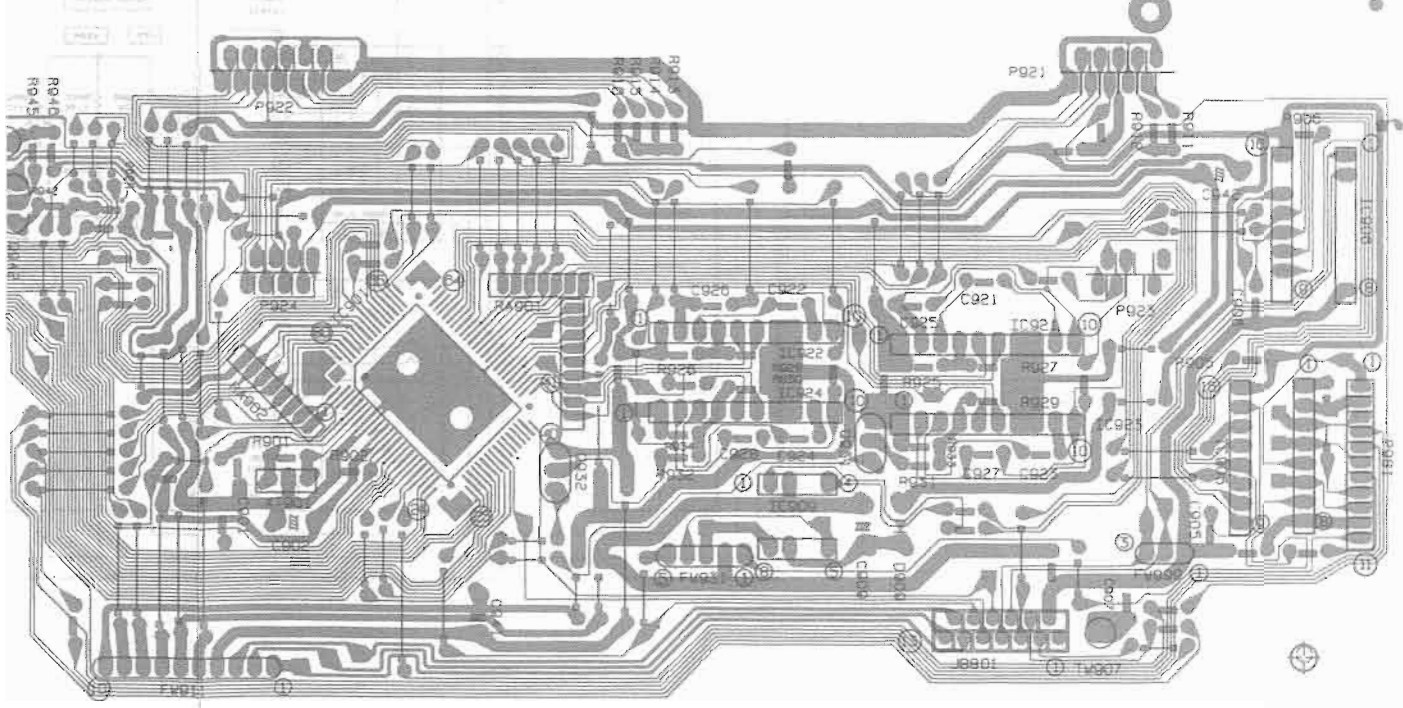
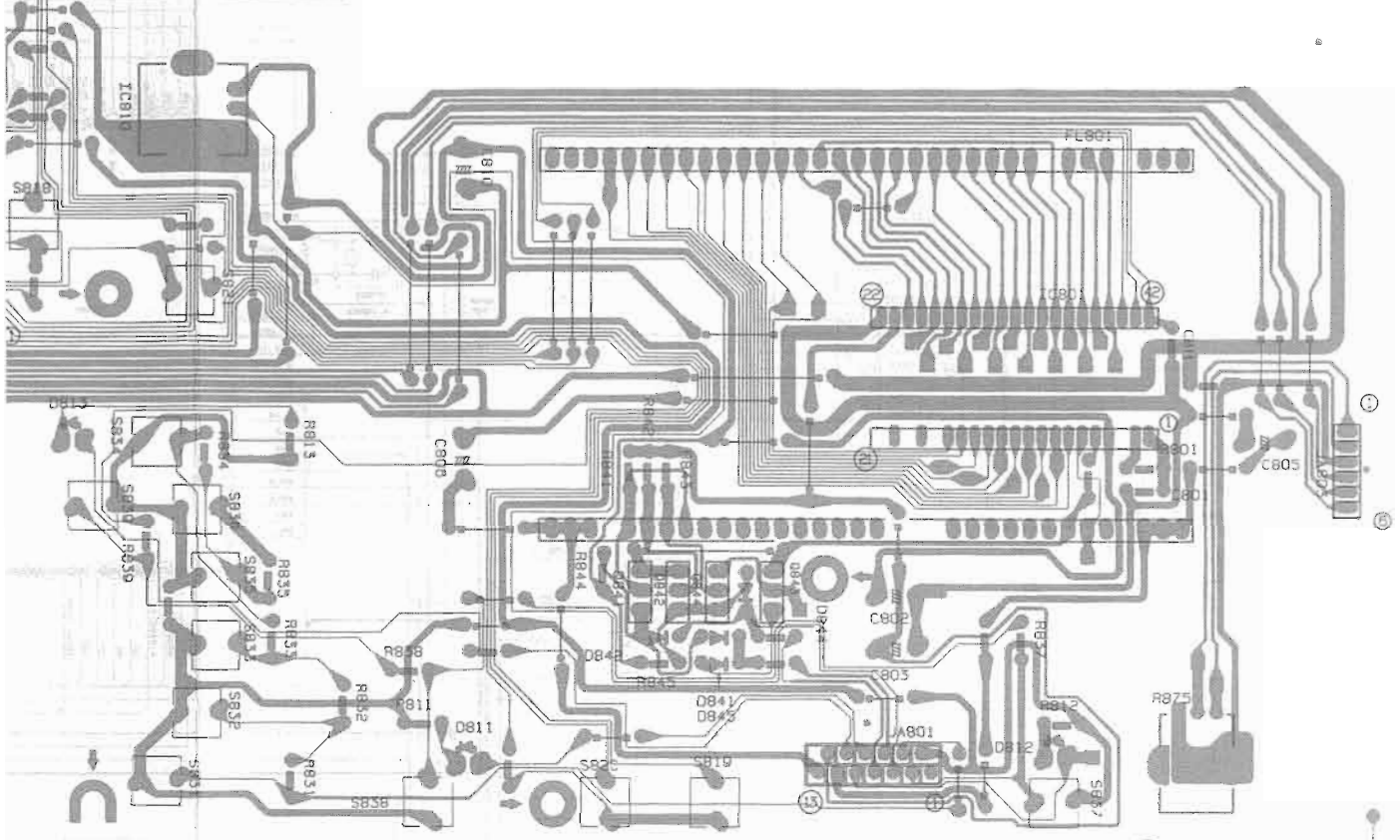
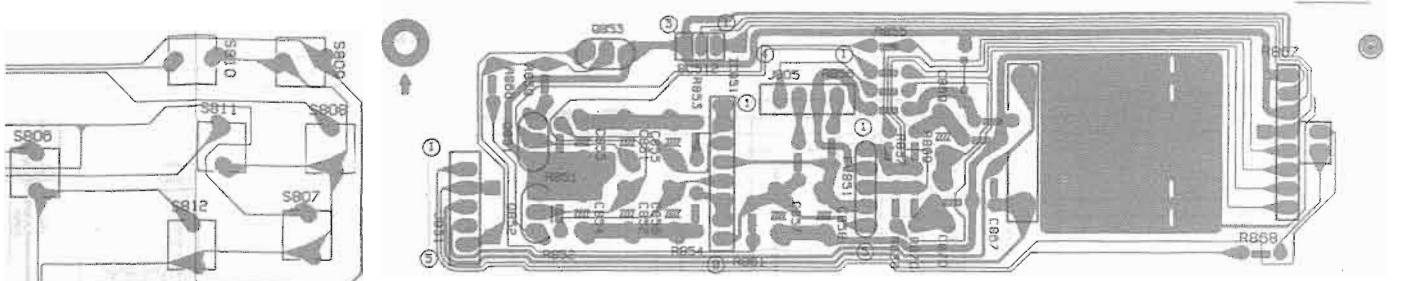

CD.S-a

CD.S-b

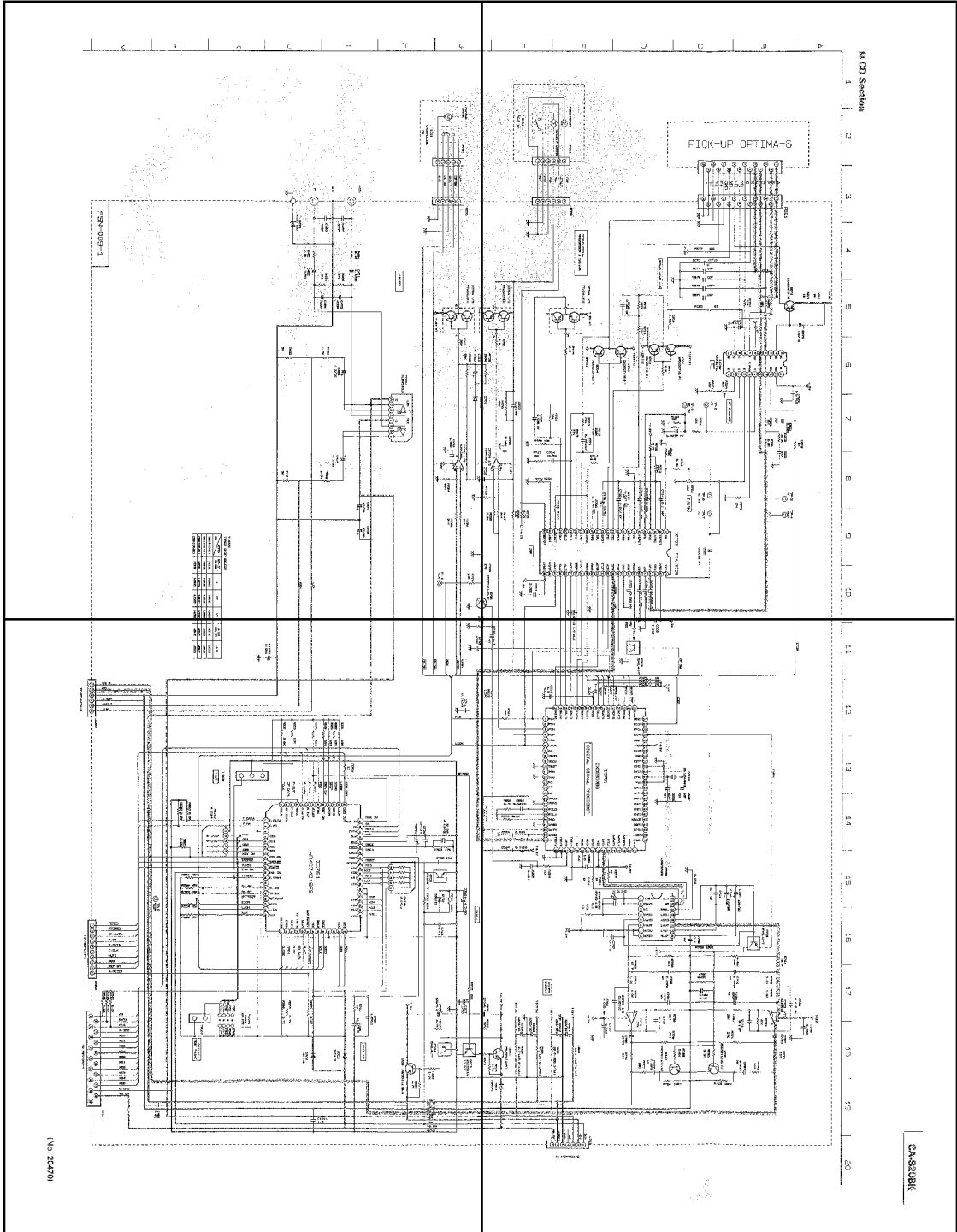

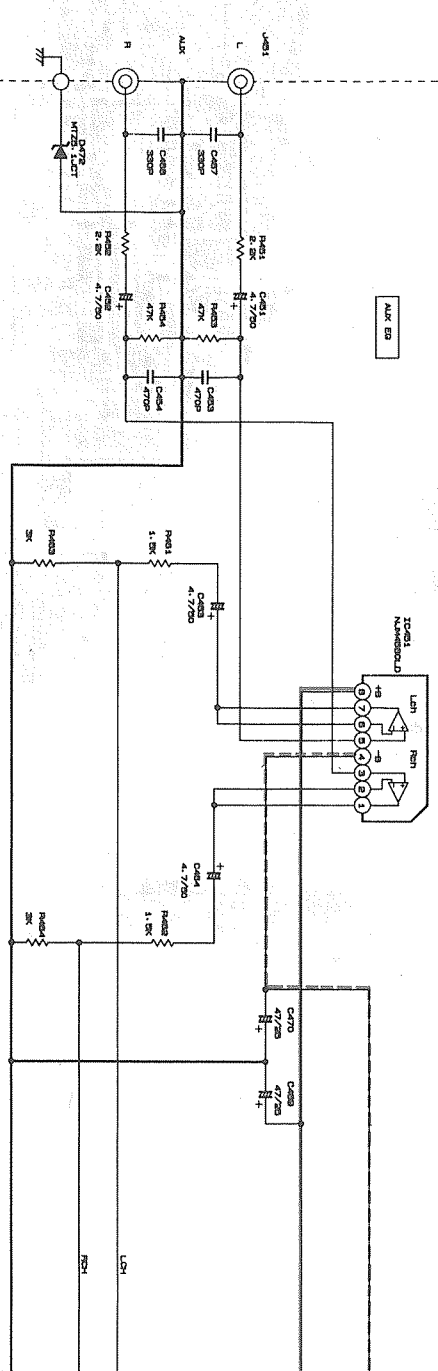
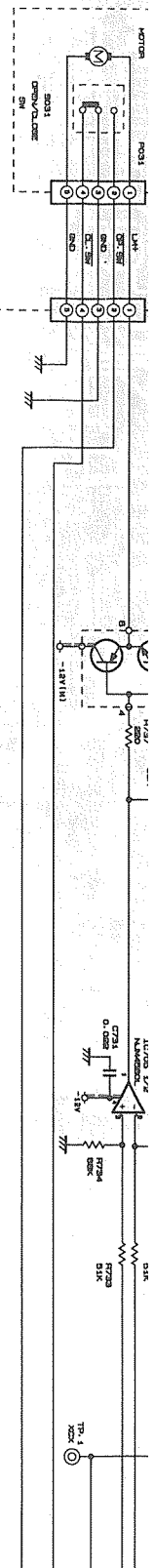

* MARK
TURNS CH-CP SELECT

CH	SEALD	SH-SP	A	OR	VA
C01 (100-41)	NONE	NONE	NONE	NONE	UNID
C02 (100-41)	NONE	NONE	NONE	NONE	UNID
C03 (100-41)	NONE	NONE	NONE	NONE	UNID
C04 (100-41)	NONE	NONE	NONE	NONE	UNID

FSN-009-1

CD Section

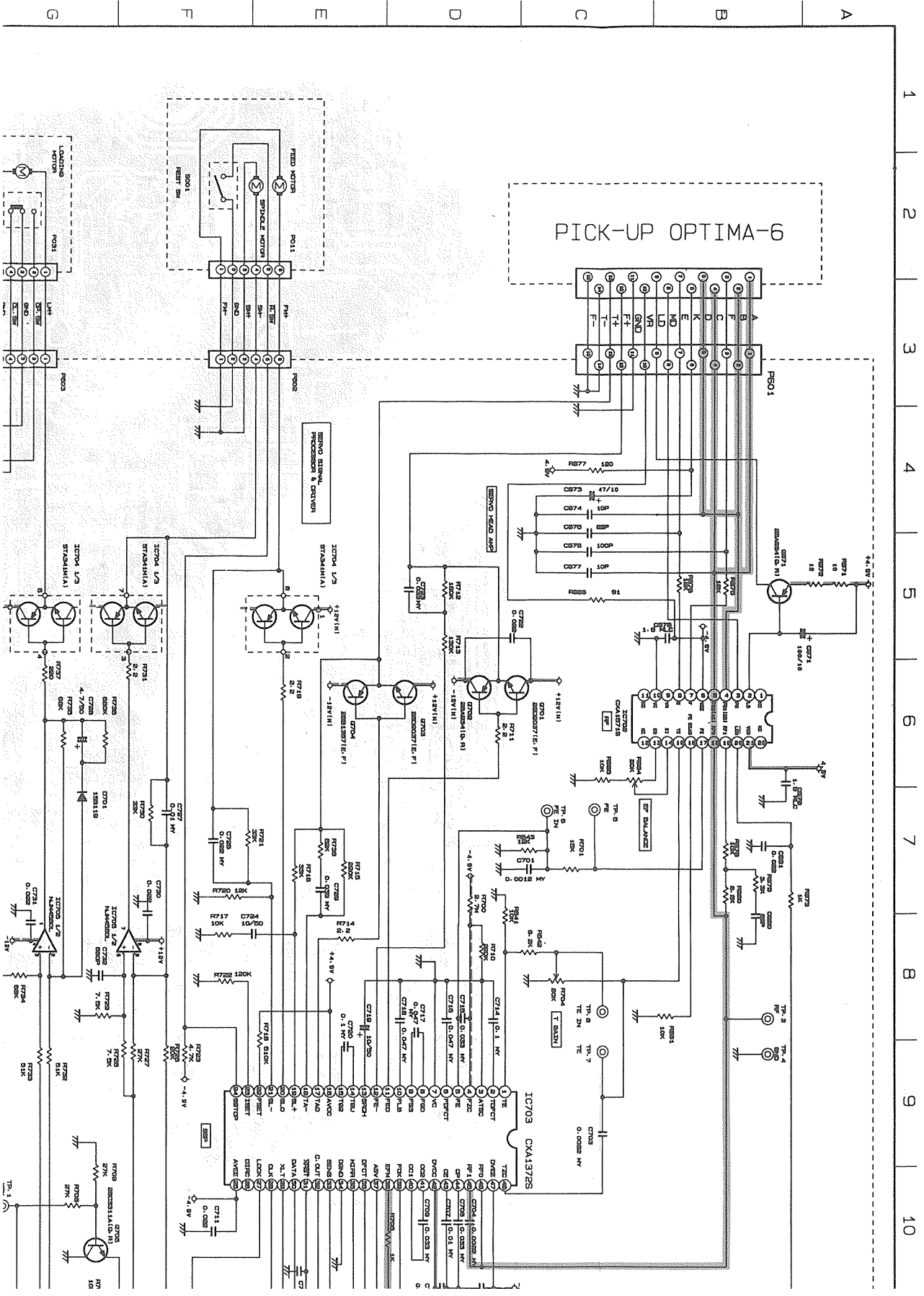

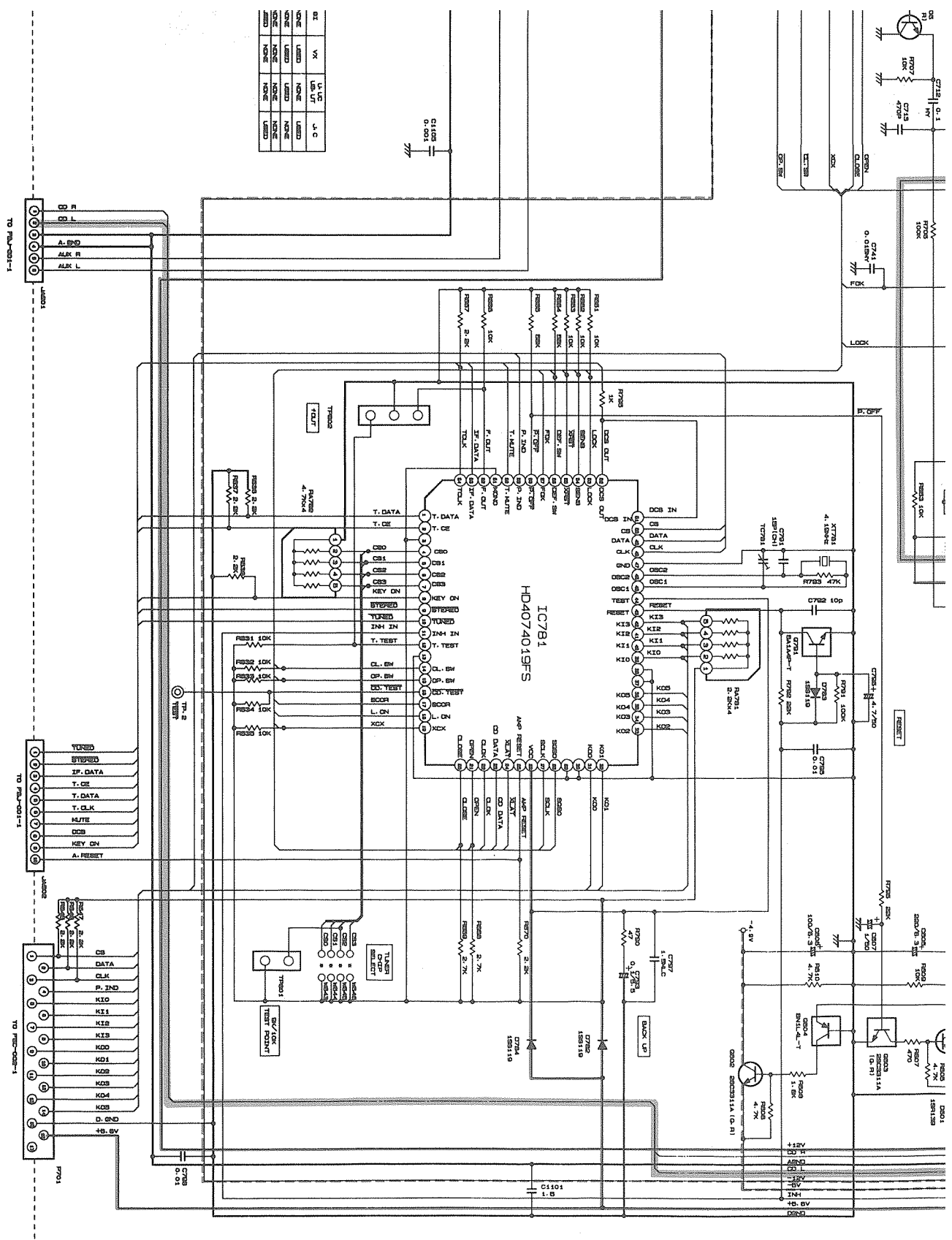

(No. 20470)

11 12 13 14 15 16 17 18 19 20

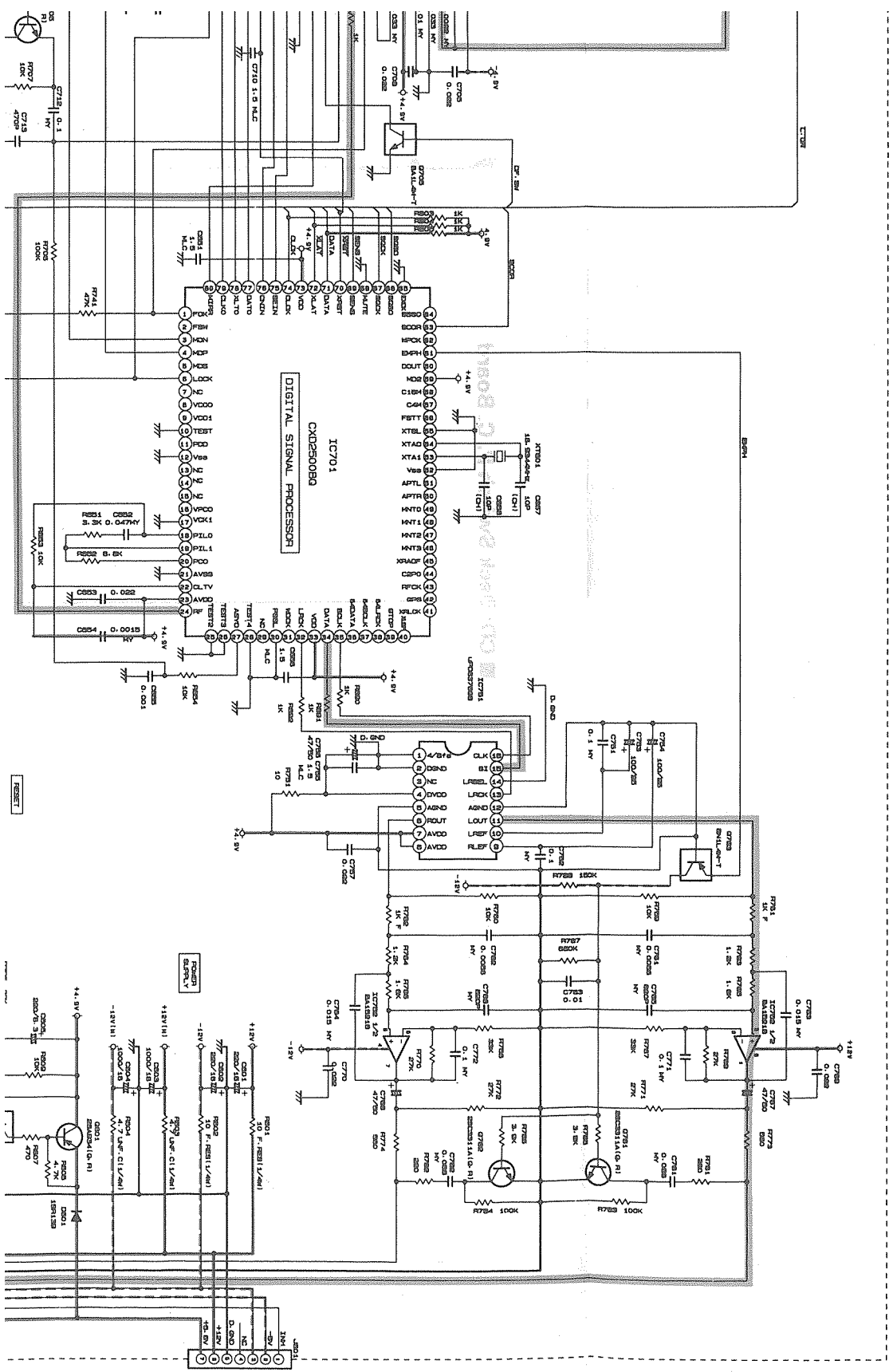

TO F8H-001-3

■ CD: Deck Switch P. C. Board

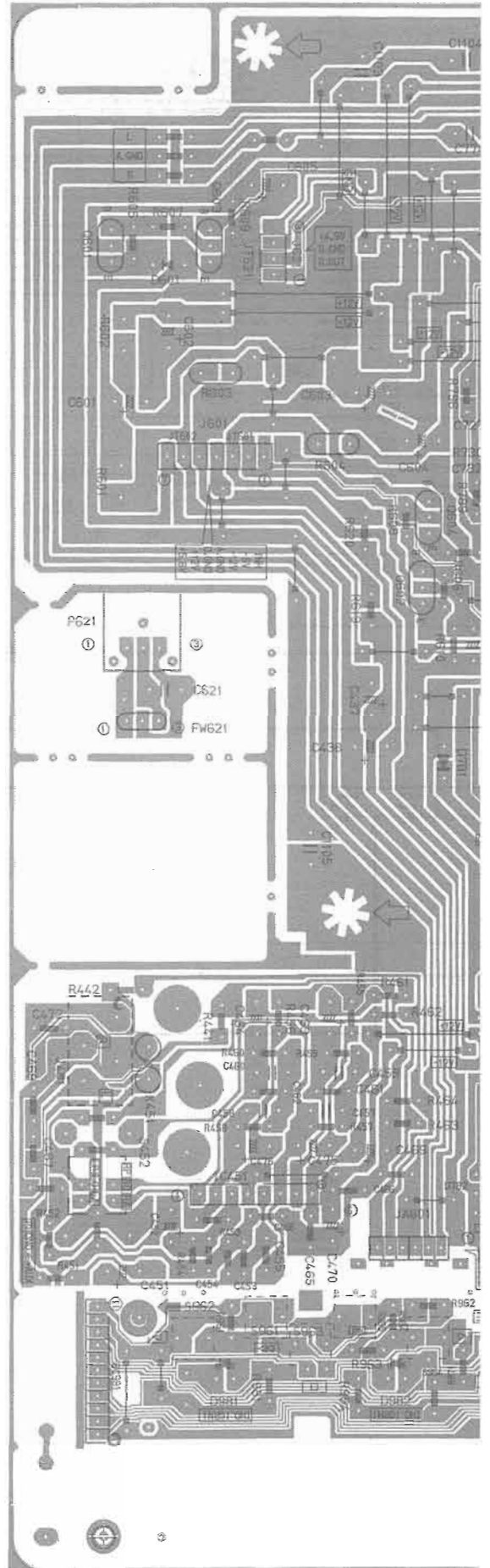

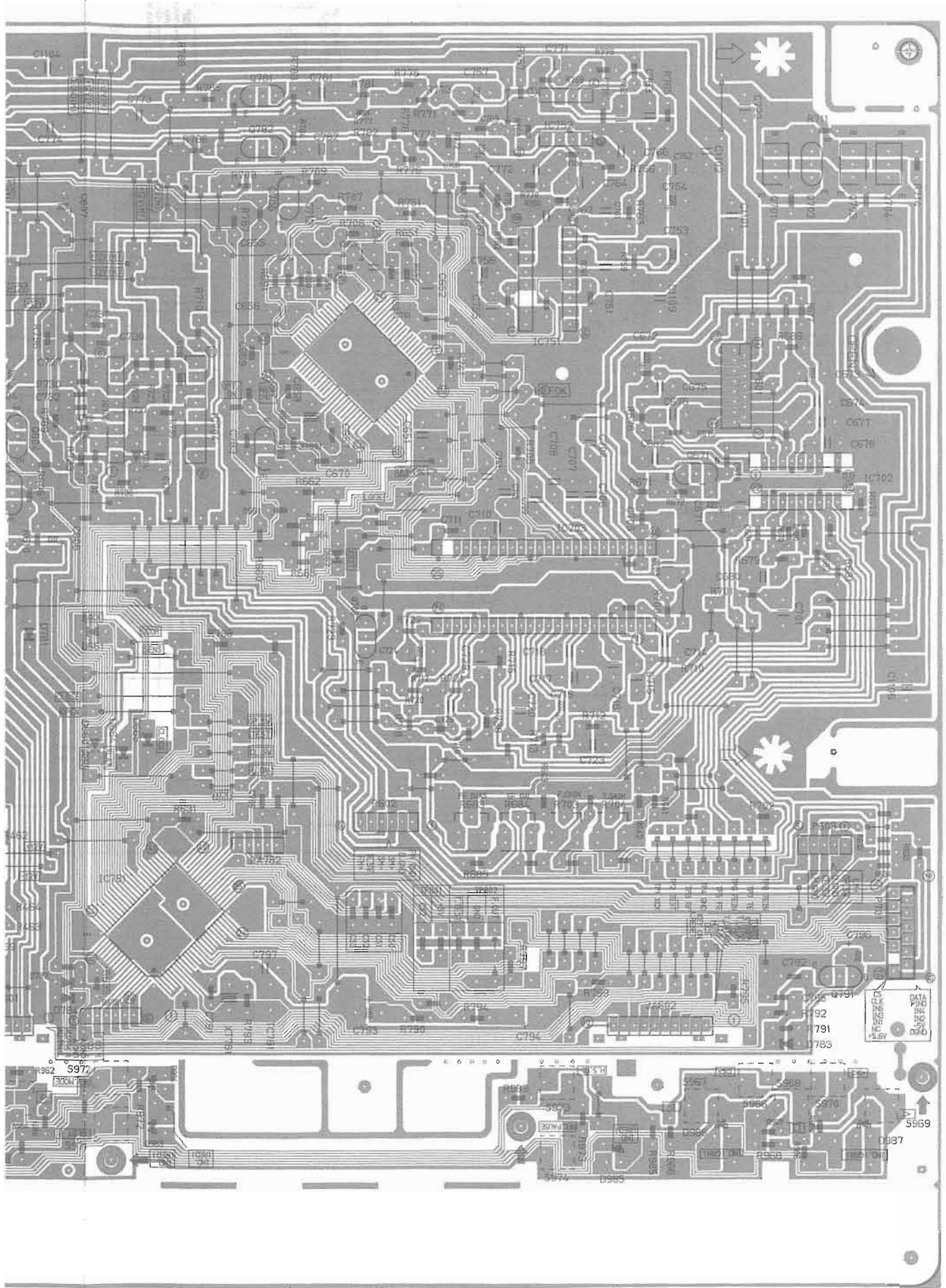

DATA
PWR
GND
5.5V

Q791
Q792
Q793
Q794

Q795
Q796
Q797
Q798
Q799
Q800
Q801
Q802
Q803
Q804
Q805
Q806
Q807
Q808
Q809
Q810
Q811
Q812
Q813
Q814
Q815
Q816
Q817
Q818
Q819
Q820
Q821
Q822
Q823
Q824
Q825
Q826
Q827
Q828
Q829
Q830
Q831
Q832
Q833
Q834
Q835
Q836
Q837
Q838
Q839
Q840
Q841
Q842
Q843
Q844
Q845
Q846
Q847
Q848
Q849
Q850
Q851
Q852
Q853
Q854
Q855
Q856
Q857
Q858
Q859
Q860
Q861
Q862
Q863
Q864
Q865
Q866
Q867
Q868
Q869
Q870
Q871
Q872
Q873
Q874
Q875
Q876
Q877
Q878
Q879
Q880
Q881
Q882
Q883
Q884
Q885
Q886
Q887
Q888
Q889
Q890
Q891
Q892
Q893
Q894
Q895
Q896
Q897
Q898
Q899
Q900
Q901
Q902
Q903
Q904
Q905
Q906
Q907
Q908
Q909
Q910
Q911
Q912
Q913
Q914
Q915
Q916
Q917
Q918
Q919
Q920
Q921
Q922
Q923
Q924
Q925
Q926
Q927
Q928
Q929
Q930
Q931
Q932
Q933
Q934
Q935
Q936
Q937
Q938
Q939
Q940
Q941
Q942
Q943
Q944
Q945
Q946
Q947
Q948
Q949
Q950
Q951
Q952
Q953
Q954
Q955
Q956
Q957
Q958
Q959
Q960
Q961
Q962
Q963
Q964
Q965
Q966
Q967
Q968
Q969
Q970
Q971
Q972
Q973
Q974
Q975
Q976
Q977
Q978
Q979
Q980
Q981
Q982
Q983
Q984
Q985
Q986
Q987
Q988
Q989
Q990
Q991
Q992
Q993
Q994
Q995
Q996
Q997
Q998
Q999
Q1000

C.D.S-a

C.D.S-b

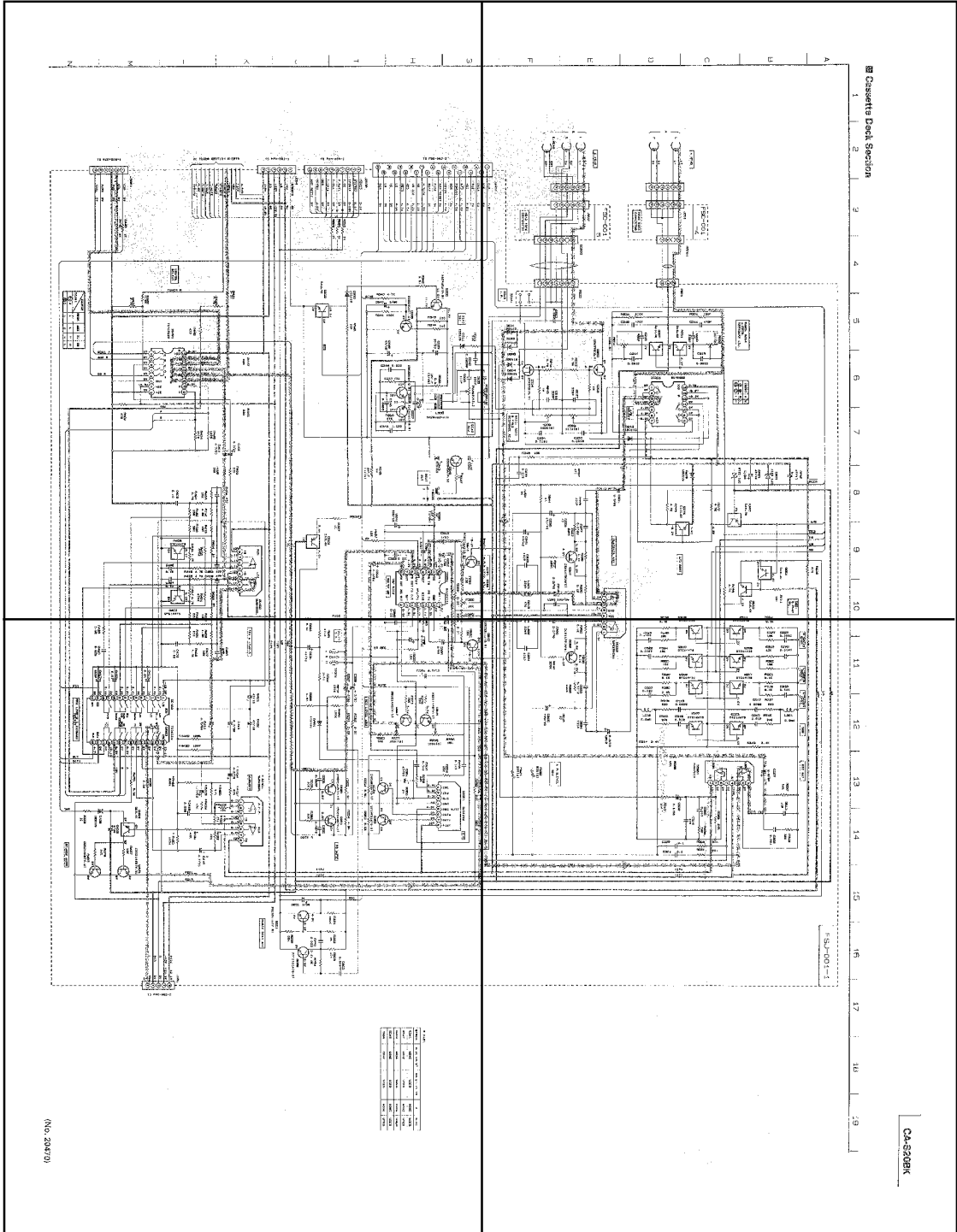

C.D.S-c

C.D.S-d

Z M L X C H I G

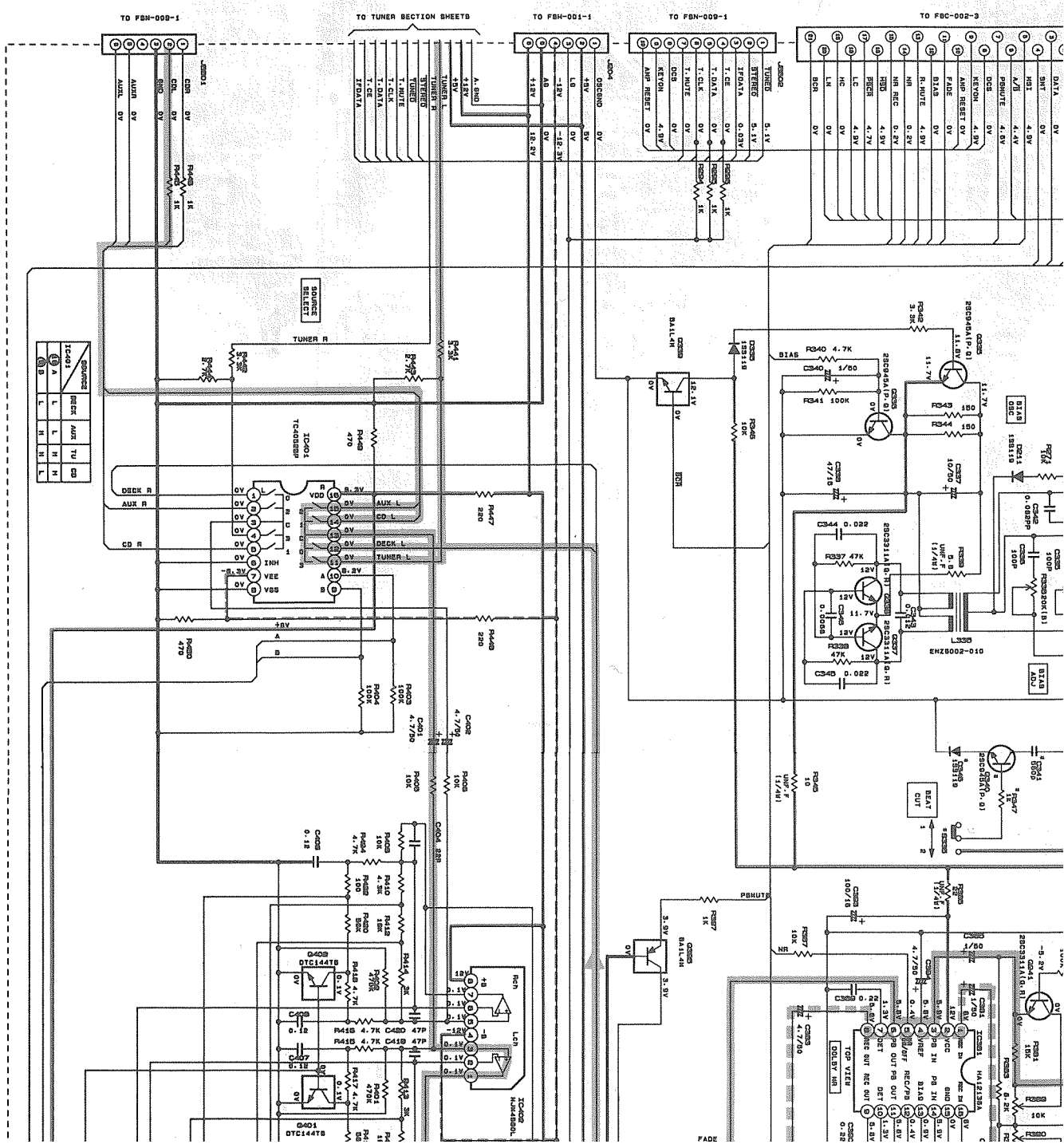

Cassette Deck Section

1 2 3 4 5 6 7 8 9 10

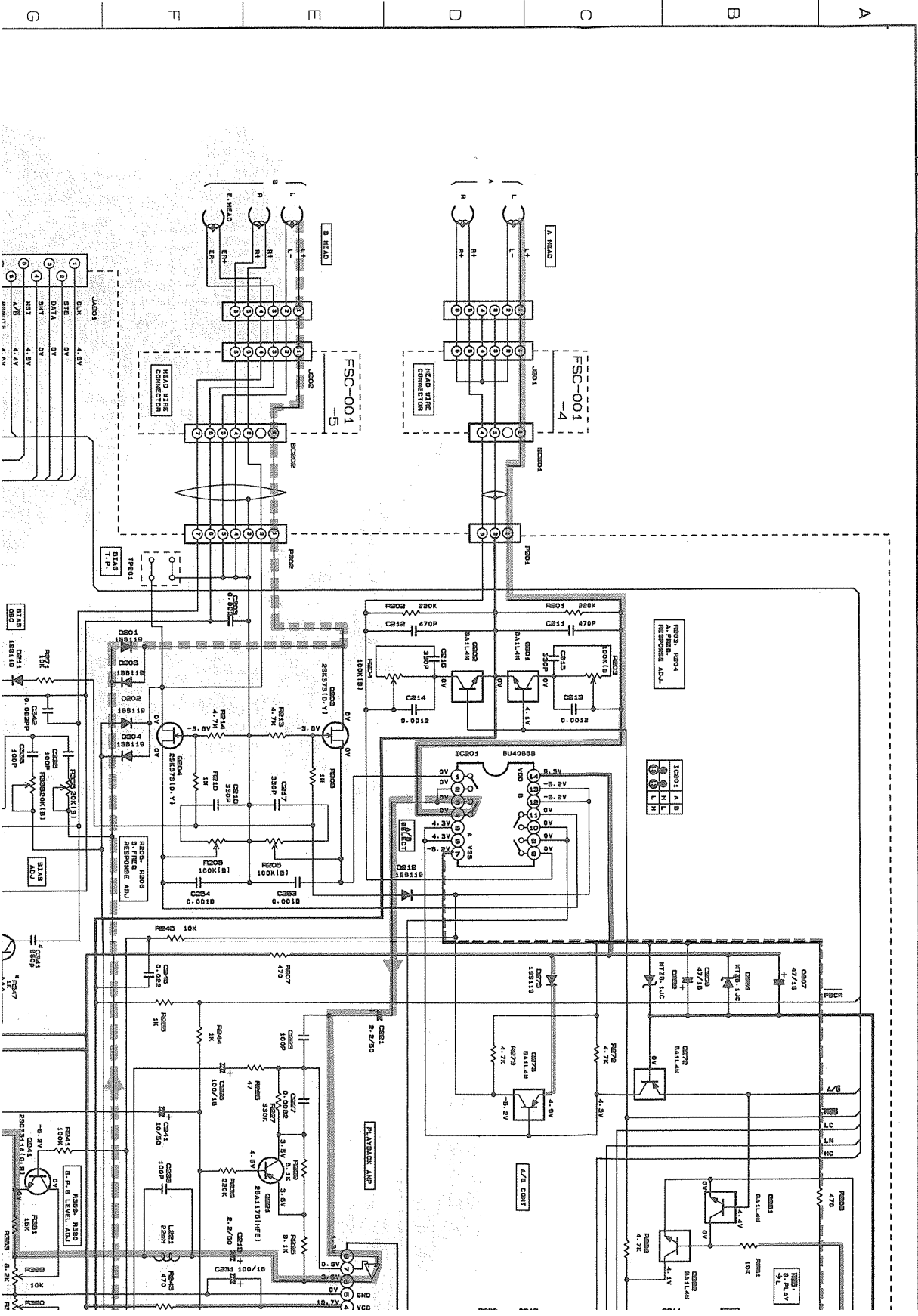

e MARK

SYMBOL	U./DC/US/UT	RES. EFF. EN. V.X	A	Q. 01
C341	NONE	USED	NONE	USED
R347	NONE	USED	NONE	USED
R348	NONE	USED	NONE	USED
R349	NONE	USED	NONE	USED
R350	NONE	USED	NONE	USED

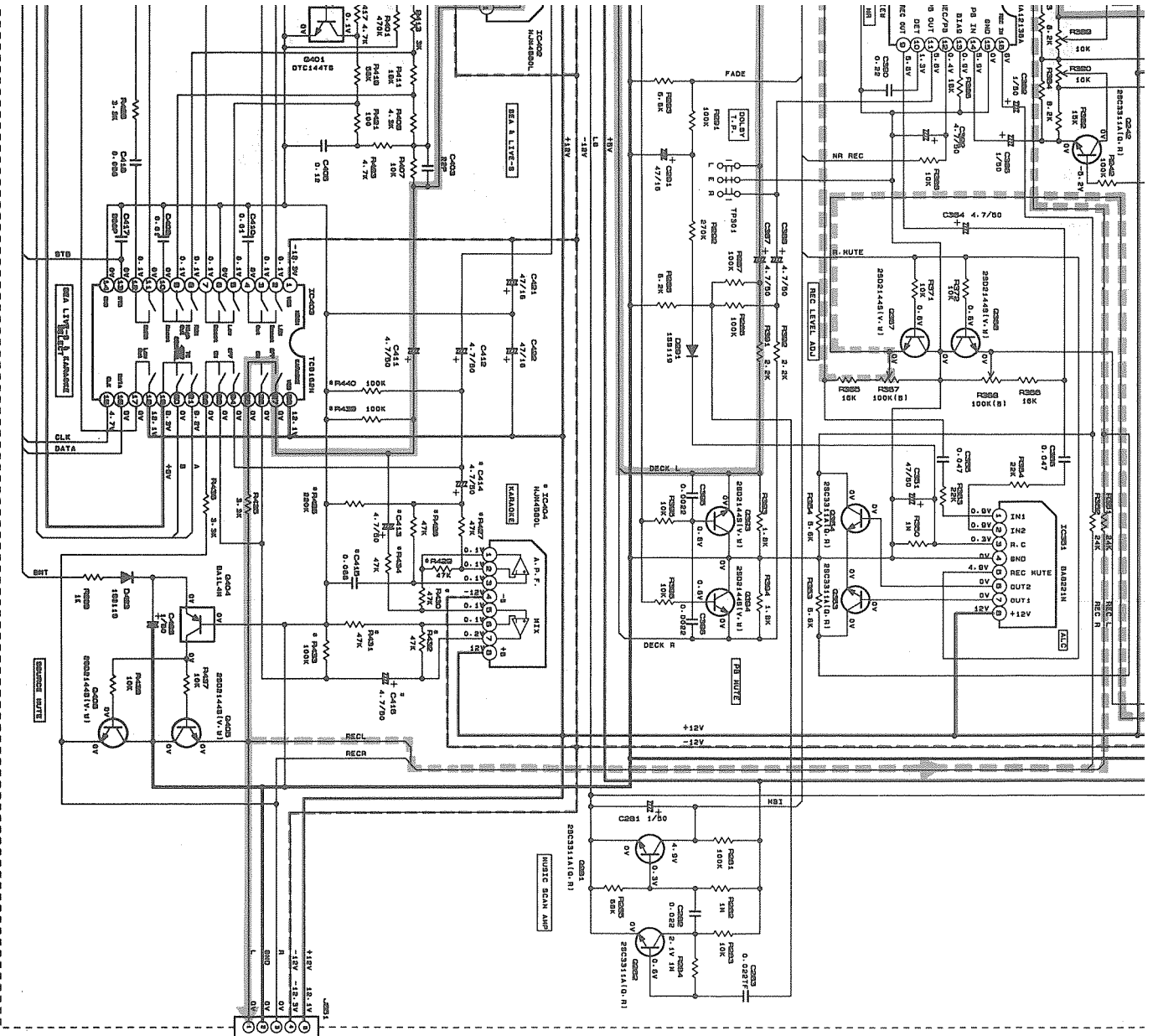

TO PBC-002-2

(No. 20470)

10 11 12 13 14 15 16 17 18 19

FSJ-001-1

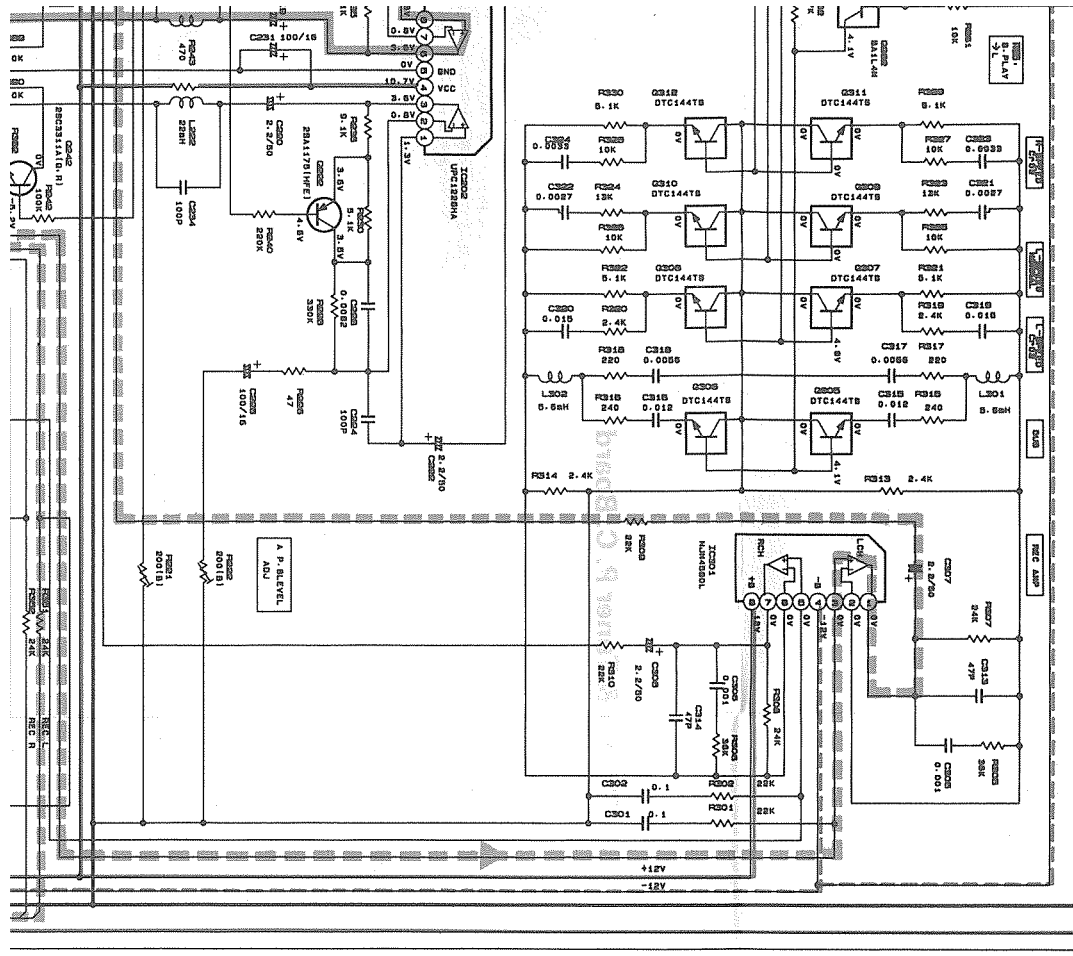

CA-S20BK

T.S-(EN...)-a

T.S-(EN...)-b

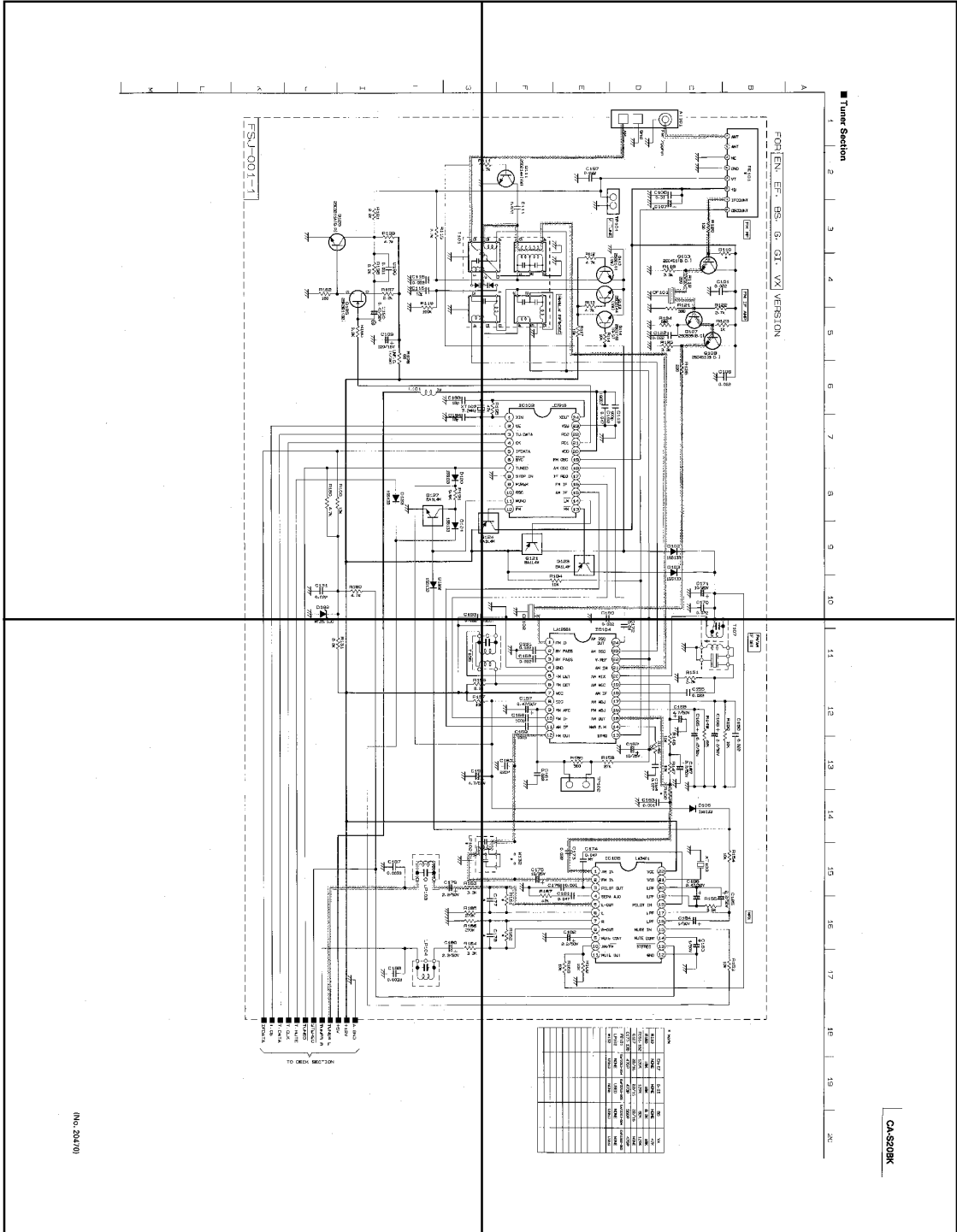

T.S-(EN...)-c

T.S-(EN...)-d

G H I J K L M

FSJ-001-1

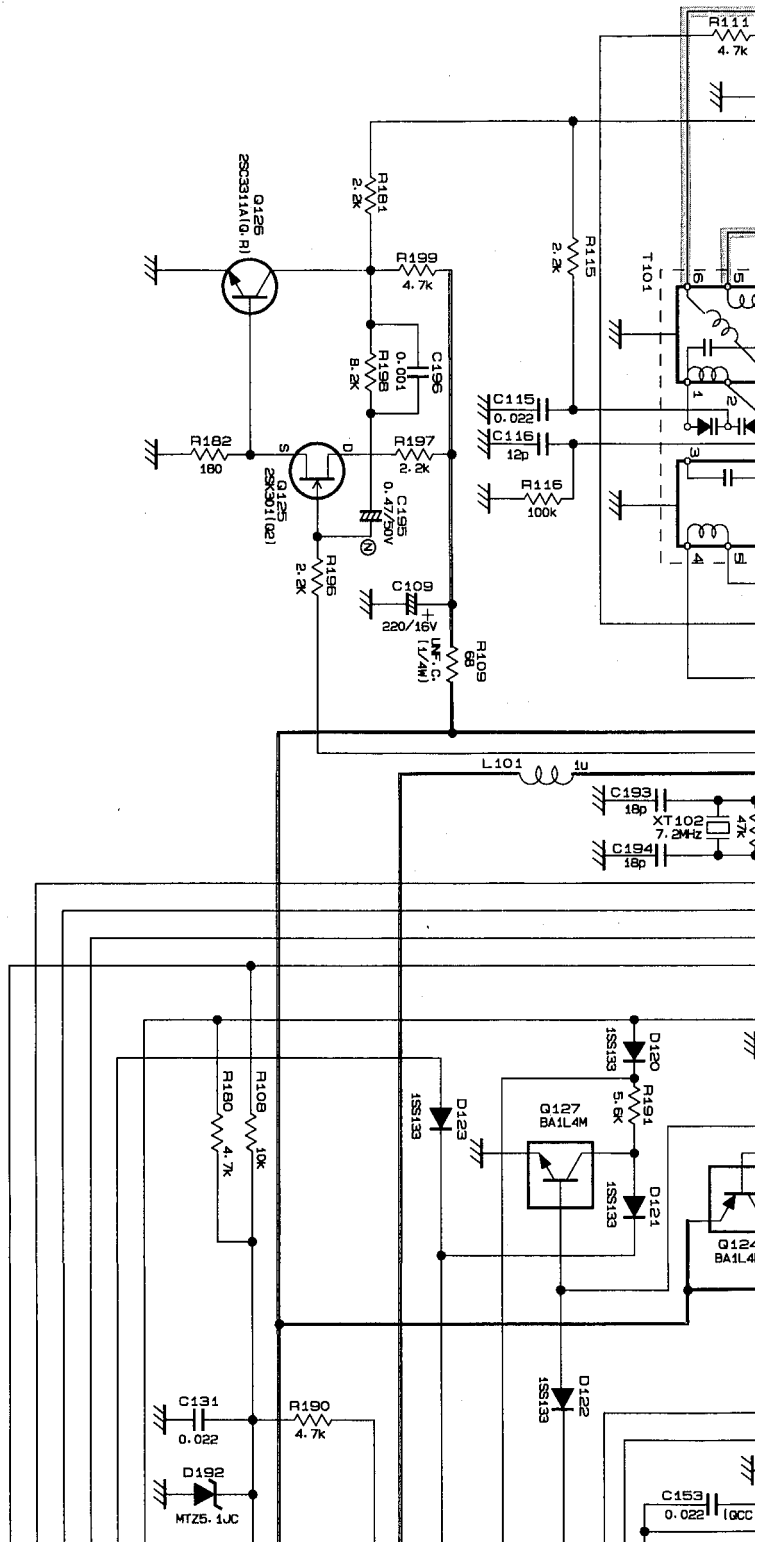

Tuner Section

FOR EN, EF, BS, G, GI, VX VERSION

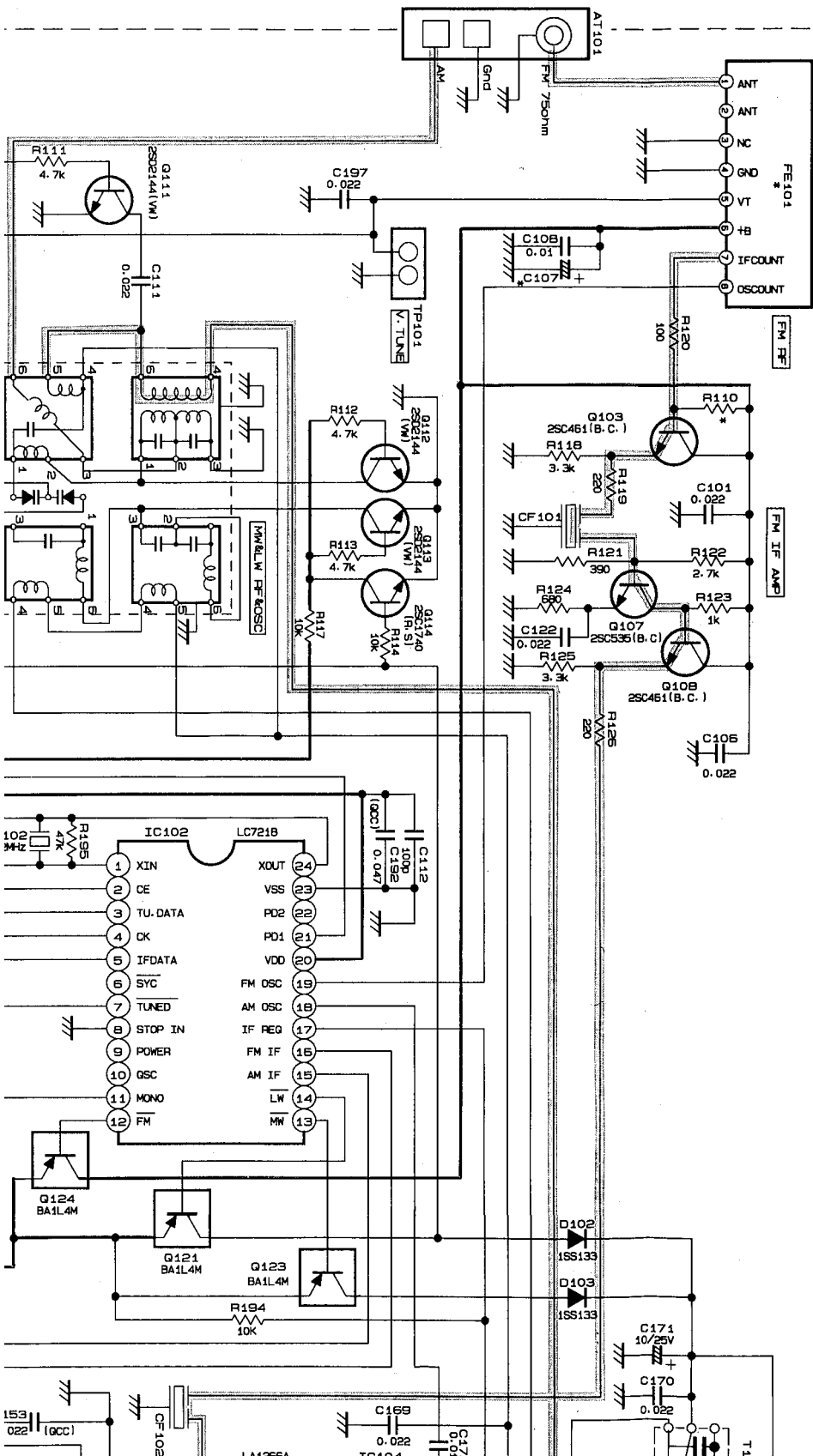

1
2
3
4
5
6
7
8
9
10

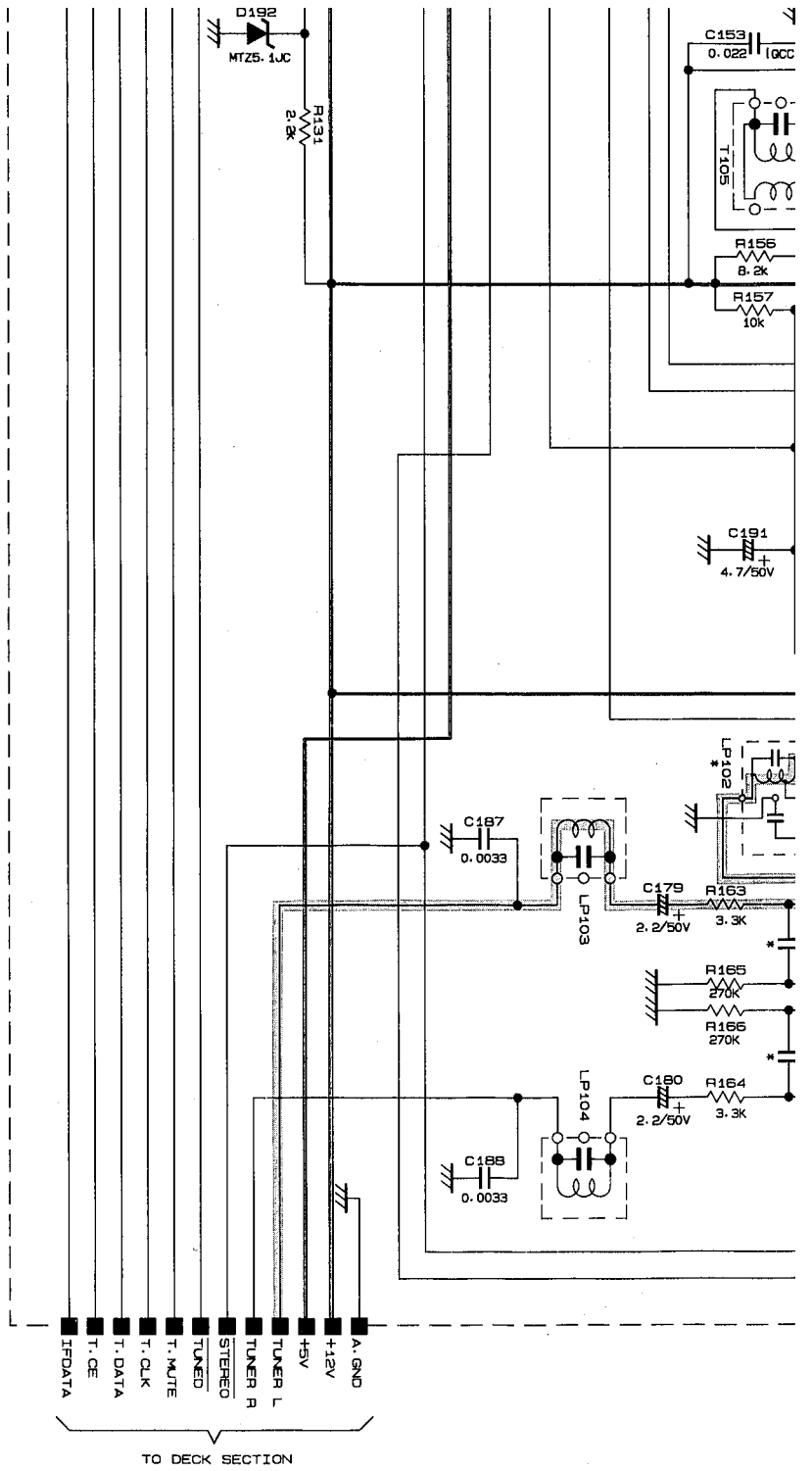

(No. 20470)

T.S-(U...)-a

T.S-(U...)-b

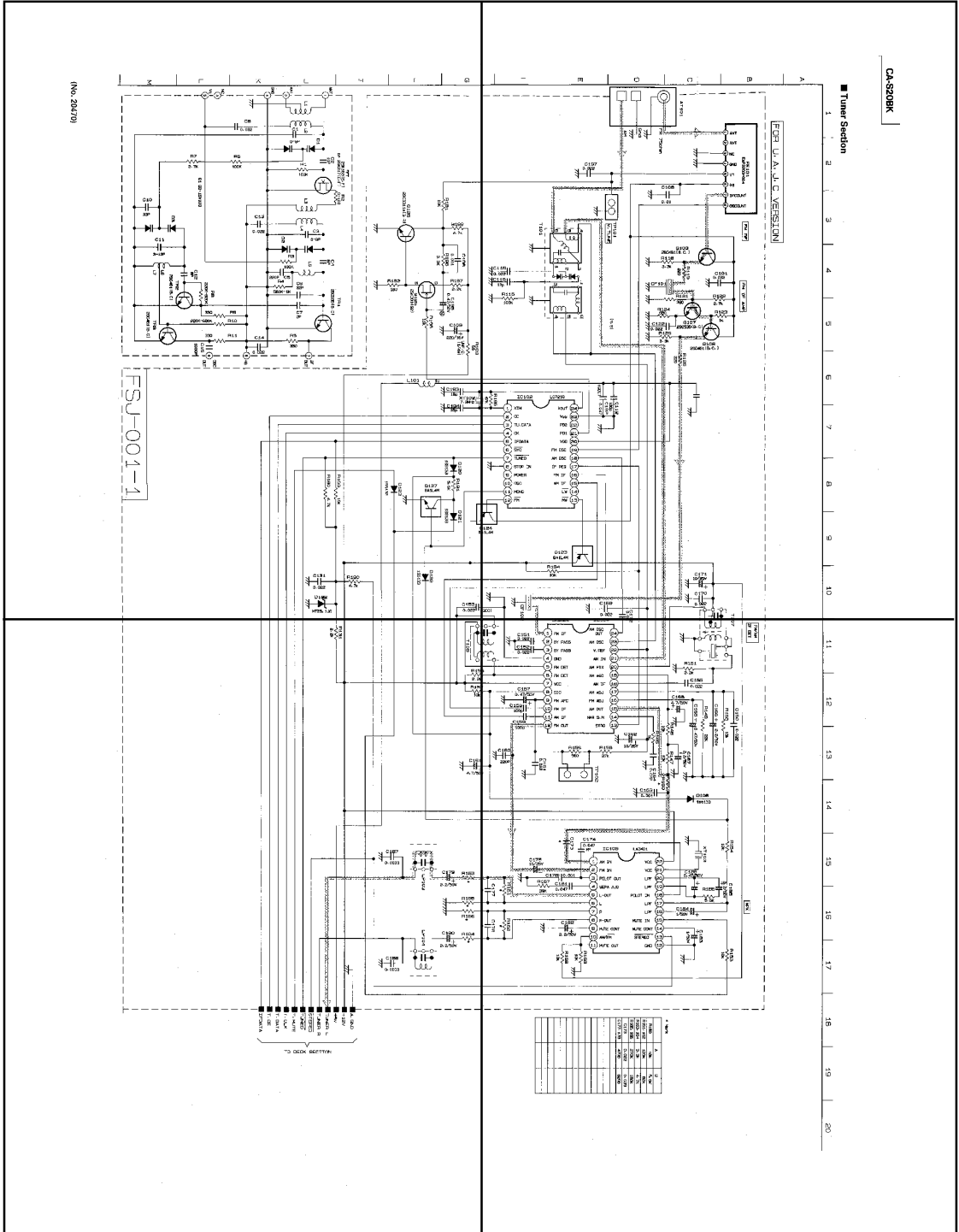

T.S-(U...)-c

T.S-(U...)-d

(No. 20470)

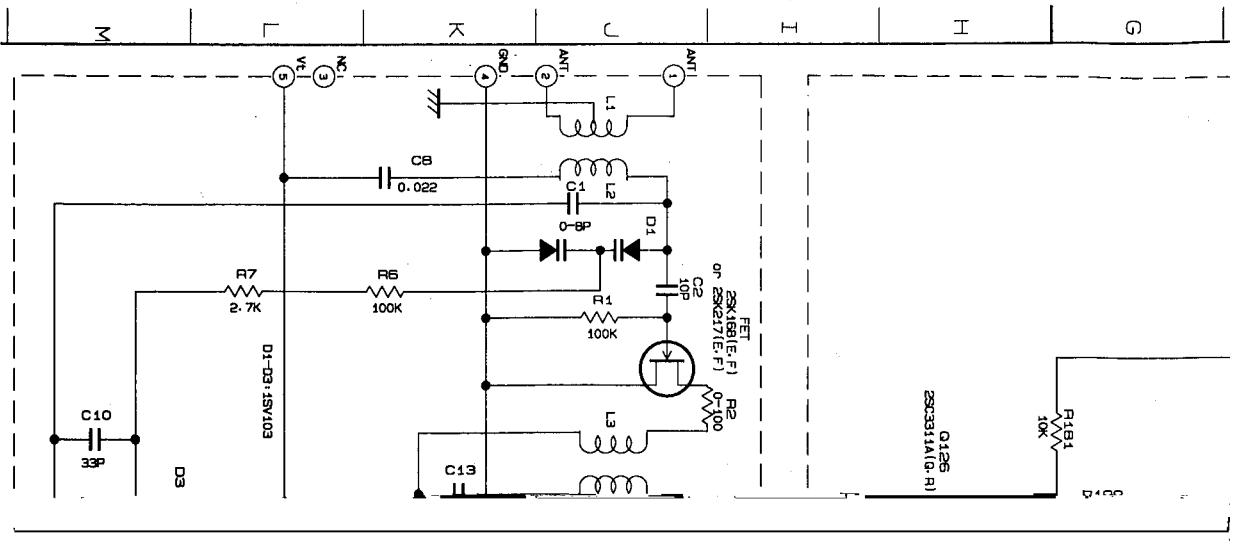

■ Tuner Section

FOR U. A. J. C VERSION

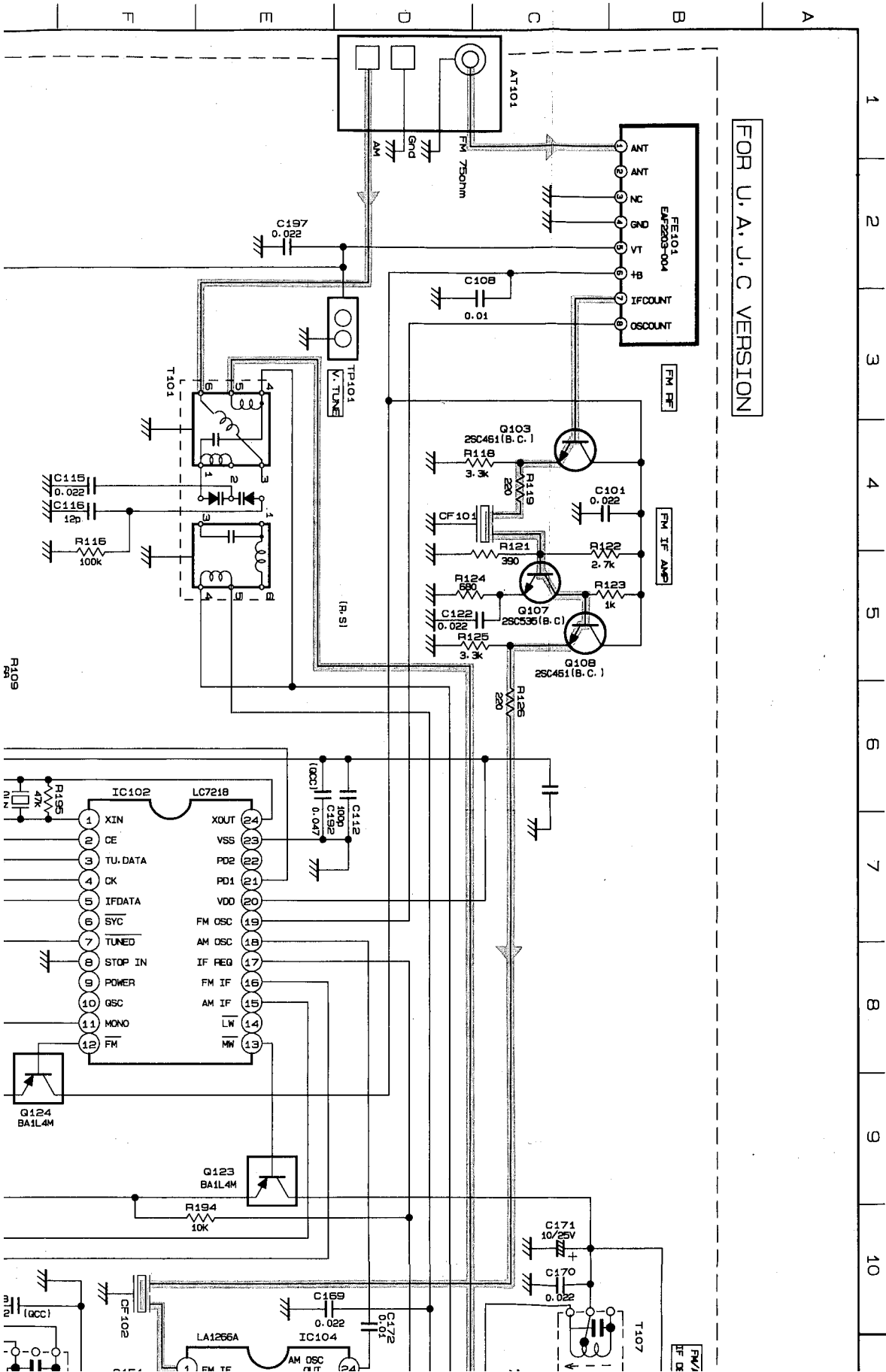

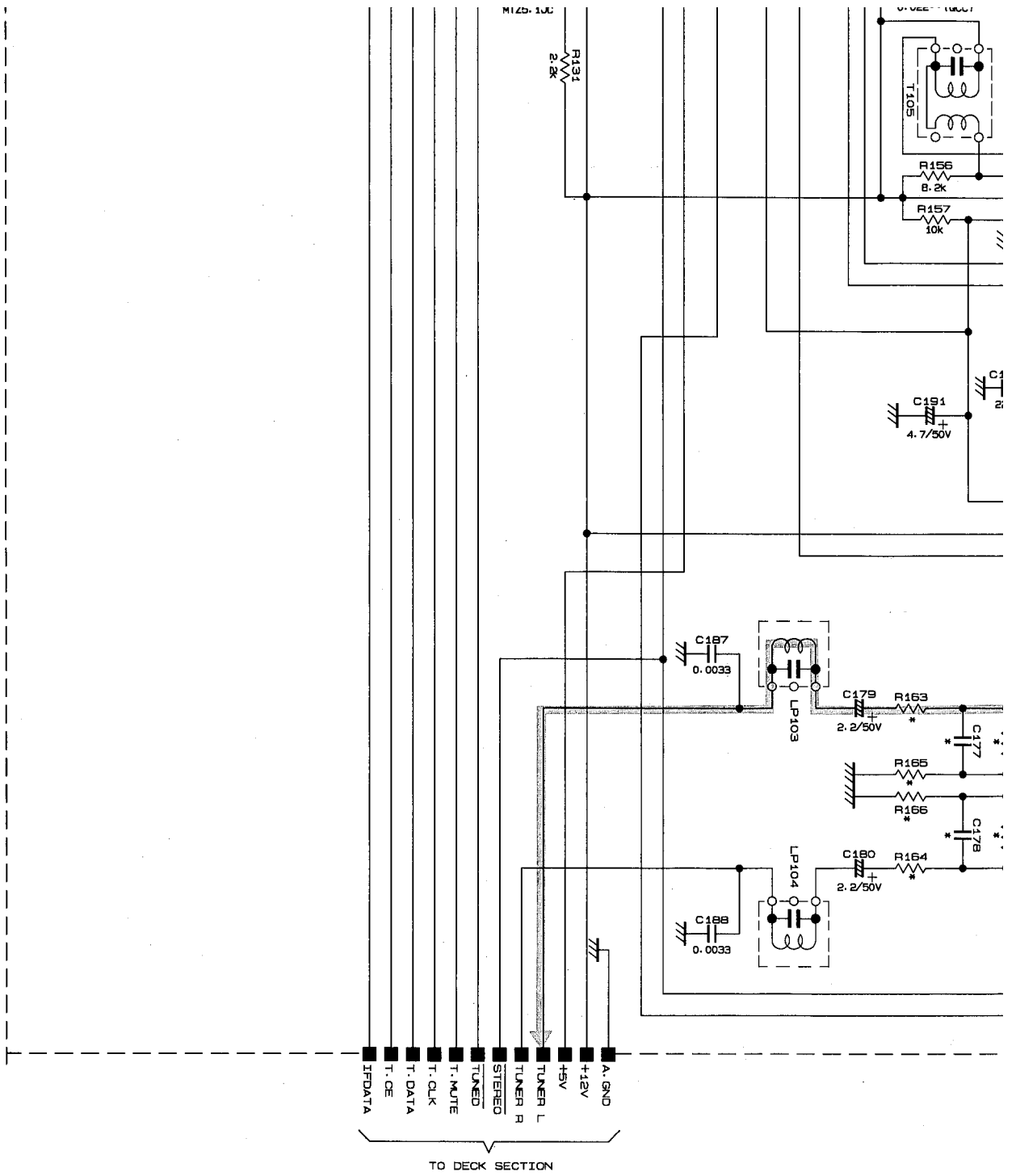

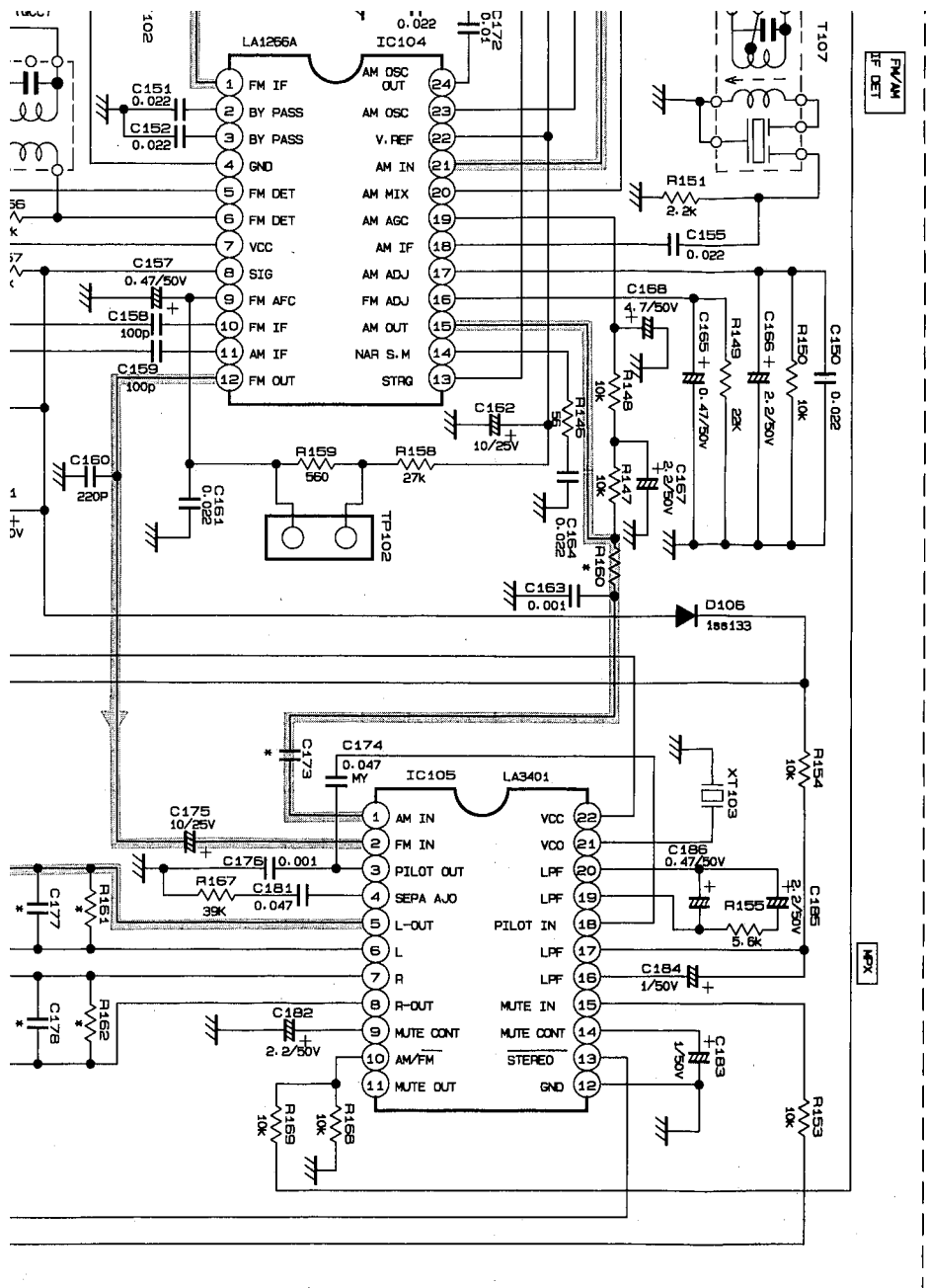

FM/AM
FM DET

MPX

* MARK

Component	A	U
R150	10K	5.6K
R151, 152	10K	82K
R153, 154	3.3K	4.7K
R155, 156	270K	10K
C173	0.022	0.039
C177, 178	470p	820p

11 | 12 | 13 | 14 | 15 | 16 | 17 | 18 | 19 | 20

PARTS LIST

Note : All printed circuit boards and its assemblies are not available as service parts.

Contents

General Exploded View and Parts List	2-3
CD Mechanism Ass'y and Parts List	2-9
Cassette Mechanism Ass'y and Parts List	2-11
Printed Circuit Board Ass'y and Parts List	2-14
■ FSH-001 <input type="checkbox"/> Power Supply, Power Amplifier, Echo & Mic Mix PC Board Ass'y ...	2-14
■ FSJ-001 <input type="checkbox"/> Deck PC Board Ass'y	2-17
■ FSN-009 <input type="checkbox"/> CD & Deck Switch PC Board Ass'y	2-24
■ FSC-002 <input type="checkbox"/> Front, Controller & Tuner PC Board Ass'y	2-27
Accessories List	2-30
Packing Materials and Part Numbers	2-32

CA-S20BK

General Exploded View and Parts List

Symbol No.

M	1	M	M
---	---	---	---

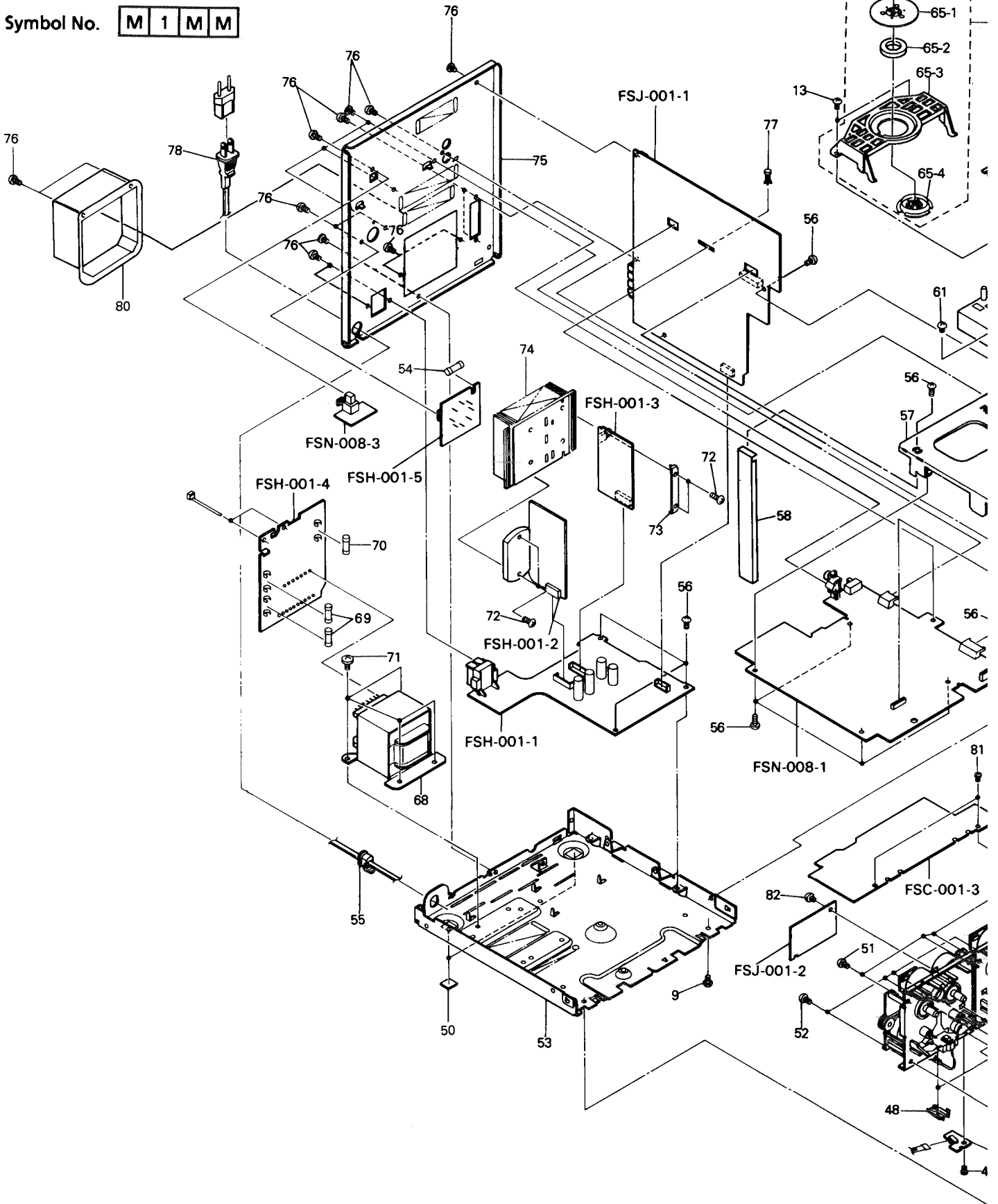

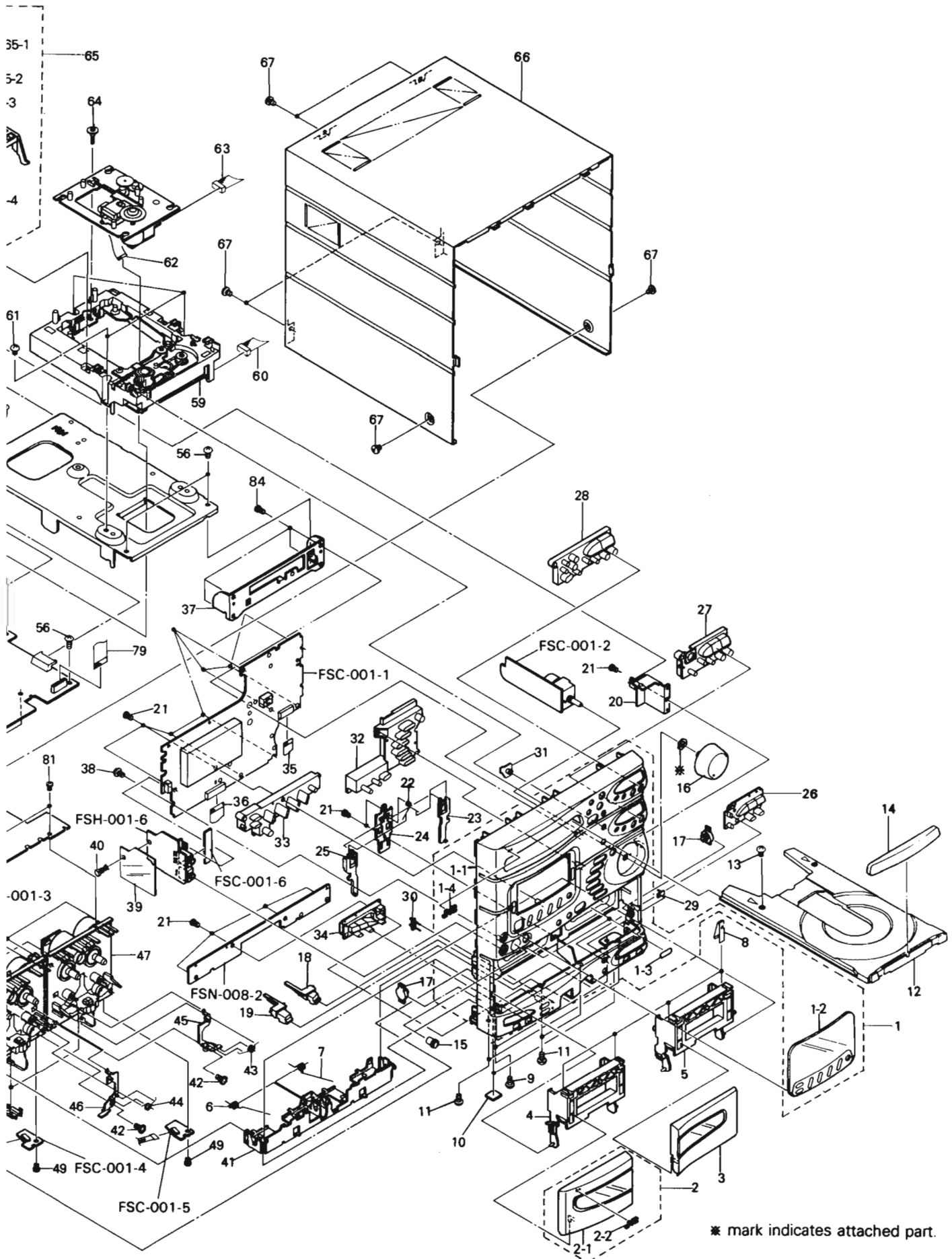

* mark indicates attached part.

CA-S20BK

Symbol No.

M	1	M	M
---	---	---	---

Parts List

Item	Part Number	Part Name	Q'ty	Description	Area
1	EFP-CAS20BKE(S)	FRONT PANEL ASSY	1		
1	EFP-CAS20BKU(S)	FRONT PANEL ASSY	1		
1-1	E102753-004	FRONT PANEL	1		A
	E102753-004	FRONT PANEL	1		BS
	E102753-004	FRONT PANEL	1		C
	E102753-004	FRONT PANEL	1		EF
	E102753-004	FRONT PANEL	1		EN
	E102753-004	FRONT PANEL	1		G
	E102753-004	FRONT PANEL	1		GI
	E102753-004	FRONT PANEL	1		J
	E102753-005	FRONT PANEL	1		U
	E102753-005	FRONT PANEL	1		UC
	E102753-005	FRONT PANEL	1		US
	E102753-005	FRONT PANEL	1		UT
	E102753-004	FRONT PANEL	1		VX
1-2	FSJD2006-001	WINDOW SCREEN	1		
1-3	E69777-003	REFLECTION PLATE	2		
1-4	E406971-221	JVC MARK	1		
2	E207966-002SA	CASSETTE LID ASSY	1		
2-1	E207966-002	CASSETTE LID ASSY	1		
2-2	E406971-221	JVC MARK	1		
3	E207969-002	CASSETTE LID ASSY	1		
4	E207972-002	CASSETTE HOLDER	1		
5	E207973-002	CASSETTE HOLDER	1		
6	E407796-001	HOLDER SPRING	1		
7	E407797-001	HOLDER SPRING	1		
8	E406713-001	CASS SPRING	4		
9	SBST3008Z	TAPPING SCREW	2		
10	EXO012012R30S	SPACER	2		
11	SBST3006M	TAPPING SCREW	4		
12	E102358-332SS	CD TRAY	1		
13	SBSF3008M	TAPPING SCREW	3		
14	E207946-002	CD FITTING	1		
15	E407233-003	VOLUME KNOB	1		
16	FSXP3012-001	VOLUME KNOB	1		
17	E304434-005	DAMPER ASSY	2		
18	E308680-001	EJECT BUTTON	1	CASSETTE B	
19	E308679-001	EJECT BUTTON	1	CASSETTE A	
20	E308684-001	P.W.BOARD BRACKET	1		
21	SDSF2608Z	SCREW	19		
22	E407798-002	SPRING	1		
23	E308682-001	EJECT LEVER	1		
24	E308683-002	EJECT GUIDE	1		
25	E308681-001	EJECT LEVER	1		
26	E207961-002	PUSH BUTTON ASSY	1	CASSETTE B	
27	E207951-002	PUSH BUTTON	1	TUNER	A
	E207951-003	PUSH BUTTON	1	TUNER	BS
	E207951-003	PUSH BUTTON	1	TUNER	C
	E207951-003	PUSH BUTTON	1	TUNER	EF
	E207951-003	PUSH BUTTON	1	TUNER	EN
	E207951-003	PUSH BUTTON	1	TUNER	G
	E207951-003	PUSH BUTTON	1	TUNER	GI
	E207951-003	PUSH BUTTON	1	TUNER	J
	E207951-002	PUSH BUTTON	1	TUNER	U
	E207951-002	PUSH BUTTON	1	TUNER	UC

CA-S20BK

⚠	Item	Part Number	Part Name	Q'ty	Description	Area
		E207951-002	PUSH BUTTON	1	TUNER	US
		E207951-003	PUSH BUTTON	1	TUNER	UT
		E207951-003	PUSH BUTTON	1	TUNER	VX
	28	E207948-002	PUSH BUTTON ASSY	1		
	29	E407795-001	INDICATOR LENS	1	REC/PAUSE	
	30	E407794-001	INDICATOR LENS	1	DOLBY/REVERSE	
	31	E407431-001SM	REMOCON LENS	1		
	32	FSXP2007-001	PUSH BUTTON ASSY	1	SORROUND	
	33	FSXP2006-001	PUSH BUTTON ASSY	1	KARAOKE	U
		FSXP2006-001	PUSH BUTTON ASSY	1	KARAOKE	UC
		FSXP2006-001	PUSH BUTTON ASSY	1	KARAOKE	US
		FSXP2006-001	PUSH BUTTON ASSY	1	KARAOKE	UT
	34	E207958-002	PUSH BUTTON ASSY	1	CASSETTE A	
	35	EWR613K-13TTJ2	FLAT WIRE ASSY	1		
	36	EWR619K-20TTJ2	FLAT WIRE ASSY	1		
	37	E308685-001	STAY BRACKET	1		
	38	E407098-001	SPECIAL SCREW	1		
	39	E407900-001	PROTECT SHEET	1		
	40	E48729-009	PLASTIC RIVET	1		
	41	E207974-002	HOLDER BRACKET	1		
	42	GBSF3006Z	TAPPING SCREW	2		
	43	E407802-002	SPRING	1		
	44	E407801-002	SPRING	1		
	45	E407800-001	EJECT BRACKET	1		
	46	E407799-001	EJECT BRACKET	1		
	47	-----	CASSETTE MECHANISM ASSY	1	SEE PAGE 2-11	
	48	VKS3655-002	HOLDER	2		
	49	SDST2604Z	SCREW	2		
	50	E75896-002	SPACER	2		
	51	SBSF3008C	TAPPING SCREW	4		
	52	SBST3006C	TAPPING SCREW	4		
	53	E102616-003SS	CHASSIS BASE	1		
⚠	54	QMF51E2-1R0J1	FUSE	1	F002	
⚠		QMF51E2-1R0J1	FUSE	1	F002	U
⚠		QMF51E2-1R0J1	FUSE	1	F002	UC
⚠		QMF51E2-1R0J1	FUSE	1	F002	US
⚠		QMF51E2-1R0J1	FUSE	1	F002	UT
⚠	55	QHS3876-162	CORD STOPPER	1		A
⚠		QHS3876-162BS	CORD STOPPER	1		BS
⚠		QHS3876-162	CORD STOPPER	1		C
⚠		QHS3876-162	CORD STOPPER	1		EF
⚠		QHS3876-162	CORD STOPPER	1		EN
⚠		QHS3876-162	CORD STOPPER	1		G
⚠		QHS3876-162	CORD STOPPER	1		GI
⚠		QHS3876-162	CORD STOPPER	1		J
⚠		QHS3876-162	CORD STOPPER	1		U
⚠		QHS3876-162	CORD STOPPER	1		UC
⚠		QHS3876-162	CORD STOPPER	1		US
⚠		QHS3876-162	CORD STOPPER	1		UT
⚠		QHS3876-162	CORD STOPPER	1		VX
	56	SBSG3008N	TAPPING SCREW	12		
	57	E102755-001	CHASSIS BASE	1		
	58	E308167-001SS	STAY BRACKET	1		
	59	-----	CD MECHANISM ASSY	1	SEE PAGE 2-9	
	60	EWS265-B408	SOCKET WIRE	1		

⚠	Item	Part Number	Part Name	Q'ty	Description	Area
	61	SBST3006Z	TAPPING SCREW	3		
	62	EWR615M-14BB	FLAT WIRE	1		
	63	EWS266-B412	SOCKET WIRE	1	6PIN	
	64	E406293-001	SPECIAL SCREW	1		
	65	E306837-005	CLAMPER BASE ASSY	1		
	65-1	E306836-003	YOKE PLATE	1		
	65-2	E74897-002	MAGNET	1		
	65-3	E26756-002	CLAMPER BASE	1		
	65-4	E306835-001	CD CLAMPER	1		
	66	E207564-001SS	METAL COVER	1		
	67	SDSG3006M	SCREW	6		
⚠	68	ETP1070-33EAJ	POWER TRANSFORMER	1		A
⚠		ETP1070-33EAJBS	POWER TRANSFORMER	1		BS
⚠		ETP1070-33JAJ	POWER TRANSFORMER	1		C
⚠		ETP1070-33EAJ	POWER TRANSFORMER	1		EF
⚠		ETP1070-33EAJ	POWER TRANSFORMER	1		EN
⚠		ETP1070-33EAJ	POWER TRANSFORMER	1		G
⚠		ETP1070-33EAJ	POWER TRANSFORMER	1		GI
⚠		ETP1070-33JAJ	POWER TRANSFORMER	1		J
⚠		ETP1070-33FAJ	POWER TRANSFORMER	1		U
⚠		ETP1070-33FAJ	POWER TRANSFORMER	1		UC
⚠		ETP1070-33FAJ	POWER TRANSFORMER	1		US
⚠		ETP1070-33FAJ	POWER TRANSFORMER	1		UT
⚠		ETP1070-33EAJ	POWER TRANSFORMER	1		VX
⚠	69	QMF51E2-1R25	FUSE	2	F501,502	A
⚠		QMF51E2-1R2J1BS	FUSE	2	F501,502	BS
⚠		QMF0007-2R0J1	FUSE	2	F501,502	C
⚠		QMF51E2-1R25	FUSE	2	F501,502	EF
⚠		QMF51E2-1R25	FUSE	2	F501,502	EN
⚠		QMF51E2-1R25	FUSE	2	F501,502	G
⚠		QMF51E2-1R25	FUSE	2	F501,502	GI
⚠		QMF0007-1R6J1	FUSE	2	F501,502	J
⚠		QMF51E2-1R25	FUSE	2	F501,502	U
⚠		QMF51E2-1R25	FUSE	2	F501,502	UC
⚠		QMF51E2-1R25	FUSE	2	F501,502	US
⚠		QMF51E2-1R25	FUSE	2	F501,502	UT
⚠		QMF51E2-1R25	FUSE	2	F501,502	VX
⚠	70	QMF51E2-1R0J1	FUSE	1	F002	A
⚠		QMF51E2-1R0J1BS	FUSE	1	F002	BS
⚠		QMF0007-2R0J1	FUSE	1	F002	C
⚠		QMF51E2-1R0J1	FUSE	1	F002	EF
⚠		QMF51E2-1R0J1	FUSE	1	F002	EN
⚠		QMF51E2-1R0J1	FUSE	1	F002	G
⚠		QMF51E2-1R0J1	FUSE	1	F002	GI
⚠		QMF0007-2R0J1	FUSE	1	F002	J
⚠		QMF51E2-2R0J1	FUSE	1	F001	U
⚠		QMF51E2-2R0J1	FUSE	1	F001	UC
⚠		QMF51E2-2R0J1	FUSE	1	F001	US
⚠		QMF51E2-2R0J1	FUSE	1	F001	UT
	71	E65389-004	SPECIAL SCREW	4		
	72	SBSG3014Z	TAPPING SCREW	4		
	73	E406969-221	LEAF SPRING	1		
	74	E307908-001SM	HEAT SINK	1		
	75	FSFC2001-001	REAR PANEL	1		A
		FSFC2001-002	REAR PANEL	1		BS

CA-S20BK

⚠	Item	Part Number	Part Name	Q'ty	Description	Area
		FSFC2001-003	REAR PANEL	1		C
		FSFC2001-003	REAR PANEL	1		EF
		FSFC2001-003	REAR PANEL	1		EN
		FSFC2001-003	REAR PANEL	1		G
		FSFC2001-004	REAR PANEL	1		GI
		FSFC2001-005	REAR PANEL	1		J
		FSFC2001-004	REAR PANEL	1		U
		FSFC2001-004	REAR PANEL	1		UC
		FSFC2001-006	REAR PANEL	1		US
		FSFC2001-004	REAR PANEL	1		UT
	76	FSFC2001-004	REAR PANEL	1		VX
		E73273-003	SPECIAL SCREW	11		U
		E73273-003	SPECIAL SCREW	13		UC
		E73273-003	SPECIAL SCREW	13		US
		E73273-003	SPECIAL SCREW	13		UT
	77	E48729-008	PLASTIC RIVET	13		A
⚠	78	QMP25F0-244	POWER CORD	1		BS
⚠		QMP5530-0085BS	POWER CORD	1		C
⚠		QMP1D00-200J5	POWER CORD	1		EF
⚠		QMP3900-200	POWER CORD	1		EN
⚠		QMP3900-200	POWER CORD	1		G
⚠		QMP3900-200	POWER CORD	1		GI
⚠		QMP3900-200	POWER CORD	1		J
⚠		QMP1D00-200J5	POWER CORD	1		U
⚠		QMP7520-200	POWER CORD	1		UC
⚠		QMP7520-200	POWER CORD	1		US
⚠		QMP3900-200	POWER CORD	1		UT
⚠		QMP7520-200	POWER CORD	1		VX
	79	EW621K-10TTJ2	FLAT WIRE ASSY	1		
	80	E207356-223	REAR COVER	1		
	81	SPST2605Z	TAPPING SCREW	2		
	82	SBSG3006N	TAPPING SCREW	1		U
		SBSG3006N	TAPPING SCREW	1		UC
		SBSG3006N	TAPPING SCREW	1		US
		SBSG3006N	TAPPING SCREW	1		UT
	-	E61029-005	NUMBER LABEL	1		
	-	E406507-001	CAUTION LABEL	1		
	-	E70891-001	CLASS 1 LABEL	1		
	-	QZL1031-101	LABEL	1		EF
	-	E70027-001	LABEL	1		EN
	-	E407619-012	FTZ LABEL	1		G
	-	E75040-036	GI LABEL	1		GI

⚠ : Safety

The Marks for Designated Areas

A	Australia	BS	the U.K.	C	Canada	EF	Continental Europe
EN	Scandinavia	G	Germany	GI	Italy	J	the U.S.A.
U	Universal Type	UC	China	US	Singapore	UT	Taiwan
VX	East Europe	No mark indicates all area.					

CD Mechanism Ass'y and Parts List

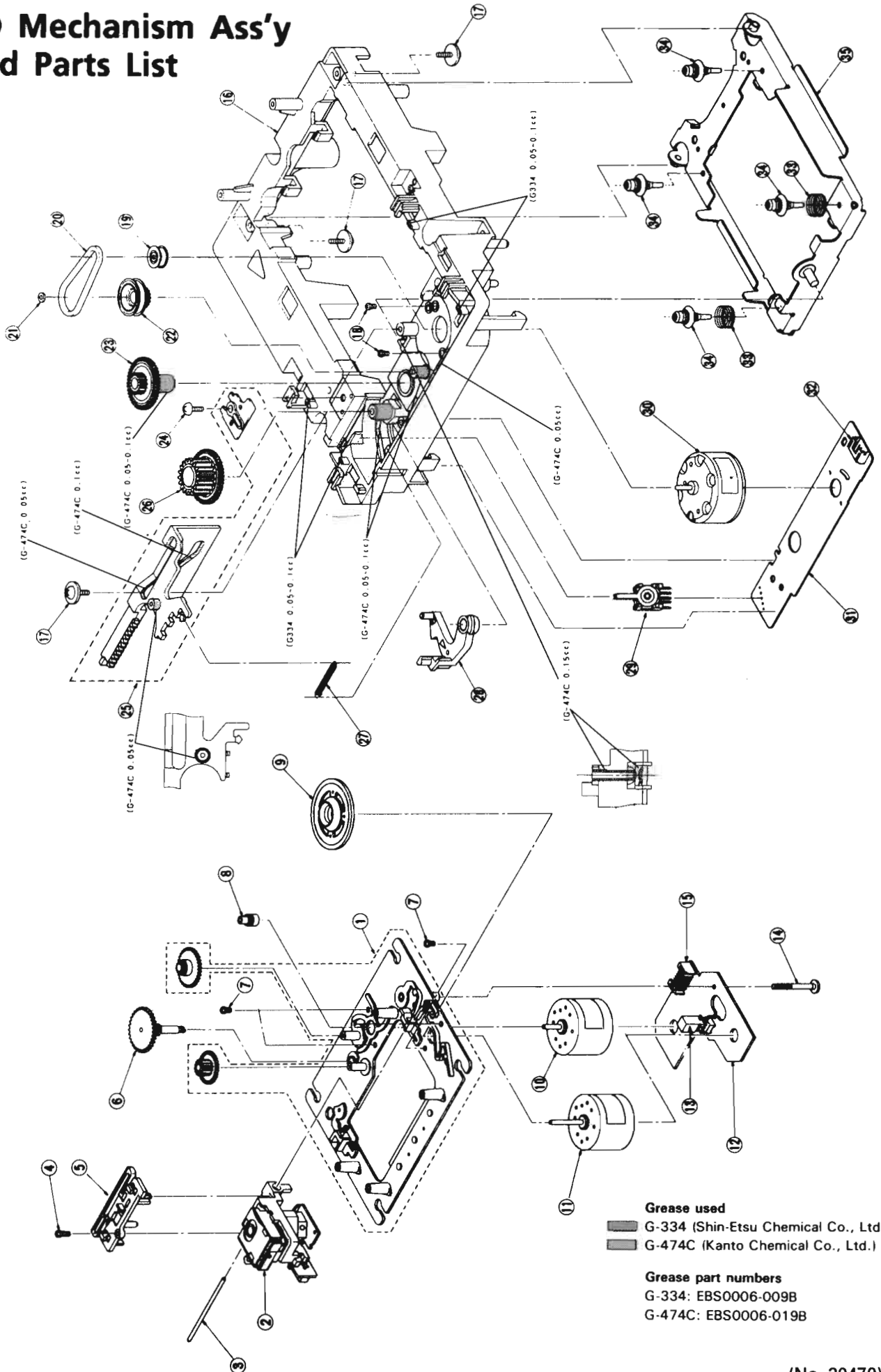

- Grease used**
- G-334 (Shin-Etsu Chemical Co., Ltd.)
 - G-474C (Kanto Chemical Co., Ltd.)
- Grease part numbers**
- G-334: EBS0006-009B
 - G-474C: EBS0006-019B

■ Parts List (CD Mechanism Ass'y)

Item	Part Number	Part Name	Q'ty	Description	Area
1	EPB-002A	MECHANISM BASE ASSY	1		
2	OPTIMA-6S	PICK UP ASS'Y	1		
3	E406777-001	SHAFT	1		
4	SDSF2006Z	SCREW	1		
5	E307746-001	CD RACK	1		
6	EPB-003A	MECHANISM BASE ASSY	1		
7	SDSP2003N	SCREW	4		
8	E406750-001	PINION GEAR	1		
9	EPB-001C	TURNTABLE	1		
10	E406784-001	DC MOTOR	1		
11	E406783-001	DC MOTOR	1		
12	EMW10190-001(S)	CIRCUIT BOARD	1		
13	ESB1100-005	LEAF SWITCH	1		
14	E75832-001	SPECIAL SCREW	1		
15	EMV5109-006B	PLUG ASSY	1	6PIN	
16	E102357-221	LOADING BASE	1		
17	E65923-003	SCREW	3		
18	SPSK2640Z	SCREW	2		
19	E75984-001	MOTOR PULLEY	1		
20	E75950-002	BELT	1		
21	E72024-001	SPEED NUT	1		
22	E75985-001	GEAR	1		
23	E75986-002	GEAR	1		
24	SBSF3008Z	SCREW	1		
25	E307252-221	CAM - PLATE	1		
26	E75987-001	REEL GEAR	1		
27	E75989-001	SPRING	1		
28	E307162-221	LEVER	1		
29	ESS1200-002	SLIDE SWITCH	1		
30	RF-500TB-12560	MOTOR	1		
31	EMW10255-002(S)	CIRCUIT BOARD	1		
32	EMV5109-005B	PLUG ASSY	1	5PIN	
33	E406871-001	SPRING	2		
34	E406294-002	INSULATOR	4		
35	E307179-221	ELEVATOR BASE ASSY	1		

Cassette Mechanism Ass'y and Parts List

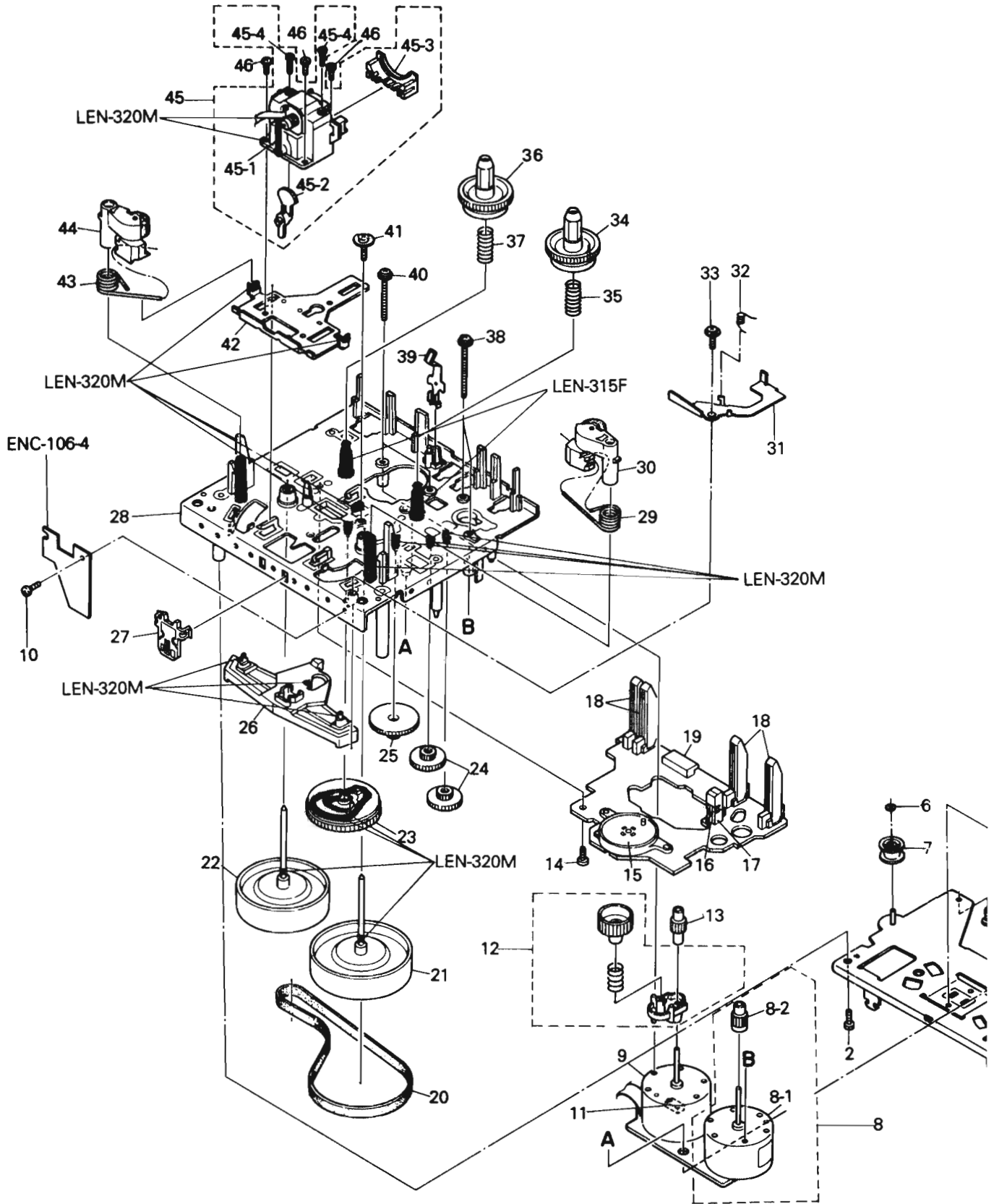

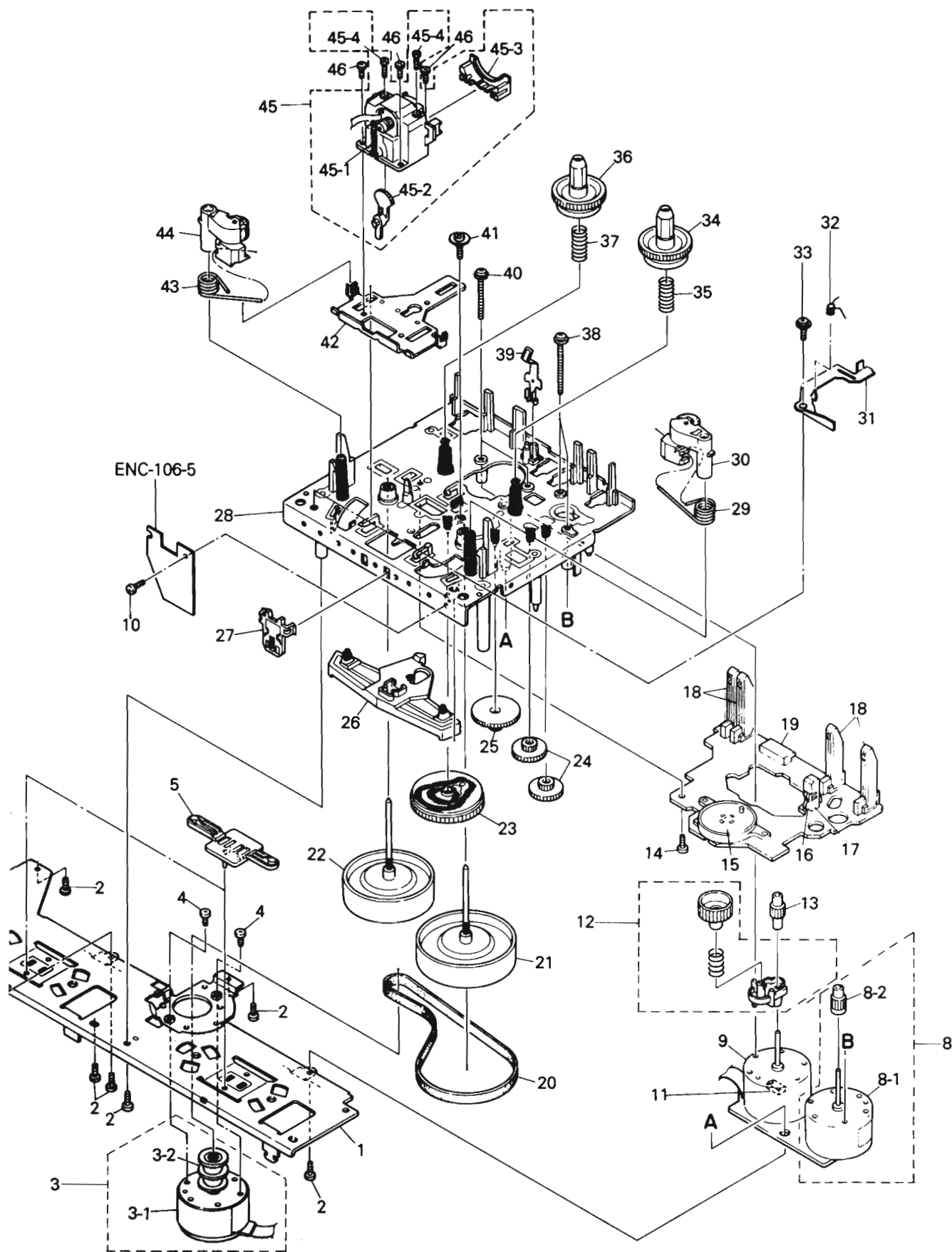

Symbol No.

M 3 M M

■ Parts List (Cassete Mechanism Ass'y)

Item	Part Number	Part Name	Q'ty	Description	Areas
1	VKL7246-001	EJECT BRACKET	2		
2	VKS3551-00B	HEAD MOUNT ASSY	1	(B)	
3	GBSF3008Z	SCREW	2		
4	VKB3001-054	CAPSTAN BELT	1	(A)	
5	VKS5321-00D	TAKE-UP REEL DISK	2	RIGHT	
6	SDST2004Z	SCREW	4	FOR HEAD MOUNT ASSY	
7	VKL6942-00E	HEAD BASE	2		
8	VKW4994-001	HEAD SPRING	2		
9	VKP4221-00C	PINCH ROLLER	2	LEFT	
10	VKW4982-001	PINCH ROLLER SPRING	2	LEFT	
11	VKW4933-005	TORSION SPRING	2	LEFT	
12	VKS1125-00A	CHASSIS BASE	2		
13	VKW4930-002	SPRING	2		
14	VKS3480-005	SUPPLY REEL DISK	2	LEFT	
15	VKW4928-003	SPRING	4	FOR REEL ASSY	
16	VKL6940-002	PINCH ROLLER LEVER	2	LEFT	
17	VKS2209-005	CONTROL CAM	2		
18	VKF3186-00C	FLYWHEEL	2	LEFT	
19	VKB3001-055	CAPSTAN BELT	1	(B)	
20	VKF3184-00C	FLYWHEEL	2	RIGHT	
21	SDSF2608Z	SCREW	2	PCB - FM BRACKET	
22	MMN-6F4RA38	DC MOTOR	2	REEL	
23	VKS5331-002	ACTUATOR GEAR	2		
24	VKS5330-004	DRIVE GEAR	2		
25	MXN-13FB12F	DC MOTOR	2	CAM	
26	VKS5329-002	PINION GEAR	2		
27	SDSP2605Z	SCREW	2	CHASSIS BASE - MOTOR	
28	VKL6939-002	PINCH ROLLER LEVER	2	RIGHT	
29	VKS5325-00F	F.F/REW.ARM	2		
30	VKS5328-002	REEL GEAR	2		
31	VKS5327-003	MECHA PLATE	2		
32	VKY4628-002	SPRING	2		
33	VKP4219-00C	PINCH ROLLER	2	RIGHT	
34	VKW4981-001	TORSION SPRING	2	RIGHT	
35	VKW4932-005	TORSION SPRING	2	RIGHT	
36	E308162-001	EJECT LEVER	2		
37	E407214-001	SPECIAL SCREW	4		
38	VKS3550-00B	HEAD MOUNT	1	(A)	
39	VMW2362-001	PRINTED BOARD	2		
40	VKS3485-002	TIMING GEAR	2		
41	VMC0249-R08N	CONNECT TERMINAL	1	(B)	
42	VMC0234-R07	CONNECT TERMINAL	2		
43	DN6851A	I.C(DIGI-OTHER)	2		
44	VKS3487-002	IC HOLDER	2		
45	VKS3587-00A	CAM SWITCH	2		
46	WDL163525-4	WASHER	1		
47	VKR4631-003	IDLER PULLEY	1		
48	VKM3618-00A	FLYWHEEL BRACKET	1		
49	SDSF2605Z	SCREW	4	CHASSIS BASE - FM BRACKET	
50	MMI-6H2LWSK	DC MOTOR	1	CAPSTAN	
51	VKR4632-002	MOTOR PULLEY	1		
52	SPSP2603Z	SCREW	2		
53	VDM007P-024I	CONNECTOR WIRE ASSY	1	(B)	
54	VDM003P-040I	CONNECTOR WIRE ASSY	1	(A)	
55	VMC0249-R04N	CONNECT TERMINAL	1	(A)	
56	E407304-001	SPRING	2		
57	EMW4816-001	CIRCUIT BOARD	2		

Transistors

Δ	ITEM	PART NUMBER	DESCRIPTION	AREA
	Q536	2SC3311A(Q,R)	SI.TRANSISTMATSUSHITA	
	Q537	2SC3311A(Q,R)	SI.TRANSISTMATSUSHITA	
	Q538	2SA1175(HFE)	SI.TRANSIST	
	Q539	2SC3311A(Q,R)	SI.TRANSISTMATSUSHITA	
	Q551	2SC3311A(Q,R)	SI.TRANSISTMATSUSHITA	
	Q552	2SD2061(F,G)	SI.TRANSISTROHM	
	Q553	2SC3311A(Q,R)	SI.TRANSISTMATSUSHITA	
	Q554	2SD2061(F,G)	SI.TRANSISTROHM	
	Q555	2SB1187(F,G)	SI.TRANSISTROHM	
	Q556	BA1L4M	DIGITAL TRA	
	Q557	BN1L4M	DIGITAL TRA	
	Q558	BN1L4M	DIGITAL TRA	
	Q559	BA1L4M	DIGITAL TRA	
	Q560	2SC3311A(Q,R)	SI.TRANSISTMATSUSHITA	
	Q561	2SD2061(F,G)	SI.TRANSISTROHM	
	Q562	2SA970(GR,BL)	SI.TRANSIST	
	Q563	2SB1187(F,G)	SI.TRANSISTROHM	
	Q571	BA1A4P	DIGITAL TRANEC	
	Q572	BA1A4P	DIGITAL TRANEC	
	Q573	2SB1357(E,F)	SI.TRANSISTROHM	

Δ : SAFETY PARTS

I.C.s

Δ	ITEM	PART NUMBER	DESCRIPTION	AREA
	IC501	STK4141MK5	I.C(HYBRID)SANYO	
	IC871	BA15218N	I.C(MONO-ANROHM)	

Δ : SAFETY PARTS

Diodes

Δ	ITEM	PART NUMBER	DESCRIPTION	AREA
	D501	1SS119	SI.DIODE	
	D502	1SS119	SI.DIODE	
	D537	1SS119	SI.DIODE	
	D538	1SS119	SI.DIODE	
	D539	10E2-FD	DIODE NIHONINTER	
	D540	10E2-FD	DIODE NIHONINTER	
	D541	10E2-FD	DIODE NIHONINTER	
	D542	10E2-FD	DIODE NIHONINTER	
	D551	MT211JC	ZENER DIODEROHM	
	D552	MT26.8JC	ZENER DIODEROHM	
	D553	MT25.6JB	ZENER DIODEROHM	
	D554	MT213JC	ZENER DIODEROHM	
	D555	MT213JC	ZENER DIODEROHM	
	D561	1SR139-200	SI.DIODE ROHM	
	D562	1SS119	SI.DIODE	
	D574	MT25.1JC	ZENER DIODEROHM	
	D575	1SS119	SI.DIODE	
	D576	MT230JC	ZENER DIODEROHM	
	D577	1SR139-200	SI.DIODE ROHM	
	D578	1SR139-200	SI.DIODE ROHM	
	D579	MT25.1JC	ZENER DIODEROHM	
	D580	1SR139-200	SI.DIODE ROHM	
	D581	1SR139-200	SI.DIODE ROHM	
	D582	1SR139-200	SI.DIODE ROHM	
	D583	1SR139-200	SI.DIODE ROHM	
	D584	1SR139-200	SI.DIODE ROHM	
	D585	1SR139-200	SI.DIODE ROHM	
	D592	1SS119	SI.DIODE	

Δ : SAFETY PARTS

Capacitors

Δ	ITEM	PART NUMBER	DESCRIPTION	AREA
	C501	QETB1EM-106	10MF 25V AL E.CAPAC	IT
	C502	QETB1EM-106	10MF 25V AL E.CAPAC	IT
	C503	QCBB1HK-221Y	220PF 50V CER.CAPACI	TO
	C504	QCBB1HK-221Y	220PF 50V CER.CAPACI	TO
	C505	QCBB1HK-101Y	100PF 50V CER.CAPACI	TO
	C506	QCBB1HK-101Y	100PF 50V CER.CAPACI	TO
	C507	QETB1EM-107	100MF 25V AL E.CAPAC	IT
	C508	QETB1EM-107	100MF 25V AL E.CAPAC	IT
	C509	QCSB1HK-4R7	4.7PF 50V CERAMIC	
	C510	QCSB1HK-4R7	4.7PF 50V CERAMIC	
	C511	QETB1HM-226E	22MF 50V E.CAPACITO	R
	C512	QETB1HM-226E	22MF 50V E.CAPACITO	R
	C513	QETB1HM-476	47MF 50V E.CAPACITO	R
	C514	QETB1HM-106	10MF 50V E.CAPACITO	R
	C515	QFLB1HJ-104	0.1MF 50V MYLAR CAPA	CI
	C516	QFLB1HJ-104	0.1MF 50V MYLAR CAPA	CI
	C536	QETB1CM-476	47MF 16V AL E.CAPAC	IT
	C537	QETB1CM-226	22MF 16V E.CAPACITO	R
	C538	EET4202-228E	2200MF E.CAPACITO	R
	C539	EET4202-228E	2200MF E.CAPACITO	R

Δ : SAFETY PARTS

Capacitors

Δ	ITEM	PART NUMBER	DESCRIPTION	AREA
	C540	QFLB2AJ-103	0.01MF 100V MYLAR CAPA	CI
	C541	QFLB2AJ-103	0.01MF 100V MYLAR CAPA	CI
	C542	QFLB2AJ-103	0.01MF 100V MYLAR CAPA	CI
	C550	QCVB1CM-103Y	0.01MF 16V CER.CAPACI	TO
	C551	QETB1CM-226	22MF 16V E.CAPACITO	R
	C552	QETB1CM-476	47MF 16V AL E.CAPAC	IT
	C553	QCVB1CM-103Y	0.01MF 16V CER.CAPACI	TO
	C554	QETB1AM-476	47MF 10V E.CAPACITO	R
	C555	QETB1AM-476	47MF 10V E.CAPACITO	R
	C556	QCVB1CM-103Y	0.01MF 16V CER.CAPACI	TO
	C557	QETB1CM-226	22MF 16V E.CAPACITO	R
	C558	QCVB1CM-103Y	0.01MF 16V CER.CAPACI	TO
	C559	QETB1CM-476	47MF 16V AL E.CAPAC	IT
	C560	QETB1EM-106	10MF 25V AL E.CAPAC	IT
	C561	QETB1EM-106	10MF 25V AL E.CAPAC	IT
	C562	QFN81HJ-103	0.01MF 50V METAL.MYLA	R
	C563	QETB1EM-106	10MF 25V AL E.CAPAC	IT
	C564	QETB1CM-226	22MF 16V E.CAPACITO	R
	C565	QFN81HJ-103	0.01MF 50V METAL.MYLA	R
	C566	QETB1CM-226	22MF 16V E.CAPACITO	R
	C571	QETB1HM-225	2.2MF 50V E.CAPACITO	R
	C573	QCGB1HK-102	1000PF 50V CER.CAPACI	TO
	C574	QETB1HM-226E	22MF 50V E.CAPACITO	R
	C575	QETB1HM-226E	22MF 50V E.CAPACITO	R
	C576	QETB1JM-476	47MF 63V AL E.CAPAC	IT
	C577	QETB1JM-107	100MF 63V AL E.CAPAC	IT
	C578	QETB1HM-475E	4.7MF 50V E.CAPACITO	R
	C579	QFLB2AJ-103	0.01MF 100V MYLAR CAPA	CI
	C580	QFLB2AJ-103	0.01MF 100V MYLAR CAPA	CI
	C581	QFLB2AJ-103	0.01MF 100V MYLAR CAPA	CI
	C582	QETM1VM-228J7	2200MF 35V E.CAPACITO	R
	C583	QETM1VM-228J7	2200MF 35V E.CAPACITO	R
	C591	QETB1HM-106	10MF 50V E.CAPACITO	R
	C871	QCGB1HK-102	1000PF 50V CER.CAPACI	TO
	C872	QETB1HM-105	1MF 50V AL E.CAPAC	IT
	C873	QCGB1HK-102	1000PF 50V CER.CAPACI	TO
	C874	QCBB1HK-101Y	100PF 50V CER.CAPACI	TO A
	C874	QCBB1HK-101Y	100PF 50V CER.CAPACI	TO BS
	C874	QCBB1HK-101Y	100PF 50V CER.CAPACI	TO EF
	C874	QCBB1HK-101Y	100PF 50V CER.CAPACI	TO EN
	C874	QCBB1HK-101Y	100PF 50V CER.CAPACI	TO GI
	C874	QCBB1HK-101Y	100PF 50V CER.CAPACI	TO VX
	C875	QETB1EM-106	10MF 25V AL E.CAPAC	IT A
	C875	QETB1EM-106	10MF 25V AL E.CAPAC	IT BS
	C875	QETB1EM-106	10MF 25V AL E.CAPAC	IT EF
	C875	QETB1EM-106	10MF 25V AL E.CAPAC	IT EN
	C875	QETB1EM-106	10MF 25V AL E.CAPAC	IT G
	C875	QETB1EM-106	10MF 25V AL E.CAPAC	IT GI
	C875	QETB1EM-106	10MF 25V AL E.CAPAC	IT VX
	C876	QCBB1HK-101Y	100PF 50V CER.CAPACI	TO
	C877	QCVB1CM-103Y	0.01MF 16V CER.CAPACI	TO U
	C877	QCVB1CM-103Y	0.01MF 16V CER.CAPACI	TO UC
	C877	QCVB1CM-103Y	0.01MF 16V CER.CAPACI	TO US
	C877	QCVB1CM-103Y	0.01MF 16V CER.CAPACI	TO UT
	C878	QCBB1HK-101Y	100PF 50V CER.CAPACI	TO
	C880	QETB1CM-226	22MF 16V E.CAPACITO	R
	C881	QETB1CM-226	22MF 16V E.CAPACITO	R
	C882	QETB1HM-105	1MF 50V AL E.CAPAC	IT
	C883	QETB1HM-475E	4.7MF 50V E.CAPACITO	R
	C892	QCBB1HK-471Y	470PF 50V CER.CAPACI	TO A
	C892	QCBB1HK-471Y	470PF 50V CER.CAPACI	TO BS
	C892	QCBB1HK-471Y	470PF 50V CER.CAPACI	TO EF
	C892	QCBB1HK-471Y	470PF 50V CER.CAPACI	TO EN
	C892	QCBB1HK-471Y	470PF 50V CER.CAPACI	TO GI
	C892	QCBB1HK-471Y	470PF 50V CER.CAPACI	TO G
	C892	QCBB1HK-471Y	470PF 50V CER.CAPACI	TO VX

Δ : SAFETY PARTS

Resistors

Δ	ITEM	PART NUMBER	DESCRIPTION	AREA
	R501	QRD167J-102	1K 1/6W CARBON RES	IS
	R502	QRD167J-102	1K 1/6W CARBON RES	IS
	R503	QRD167J-104	100K 1/6W CARBON	
	R504	QRD167J-104	100K 1/6W CARBON	
	R505	ERD004J-471	470 NETWORK RE	SI
	R506	ERD004J-471	470 NETWORK RE	SI
	R507	QRD167J-471	470 1/6W CARBON RES	IS
	R508	QRD167J-471	470 1/6W CARBON RES	IS
	R509	QRD167J-104	100K 1/6W CARBON	
	R510	QRD167J-104	100K 1/6W CARBON	
	R511	QRD161J-242	2.4K 1/6W CARBON RES	IS
	R512	QRD161J-242	2.4K 1/6W CARBON RES	IS
	R513	QRD161J-242	2.4K 1/6W CARBON RES	IS
	R514	QRD161J-242	2.4K 1/6W CARBON RES	IS
	Δ R515	QRX014J-R22	0.22 1W METAL FILM	R
	Δ R516	QRX014J-R22	0.22 1W METAL FILM	R
	Δ R517	QRZ0077-101	100 1/4W FUSIBLE RE	SI
	Δ R518	QRZ0077-100	10 1/4W FUSIBLE RE	SI
	Δ R519	QRD14CJ-100S	10 1/4W UNF.CARBON	
	Δ R520	QRD14CJ-100S	10 1/4W UNF.CARBON	

Δ : SAFETY PARTS

Resistors

Δ	ITEM	PART NUMBER	DESCRIPTION	AREA
Δ	R521	QRD14CJ-100S	10 1/4W UNF. CARBON	
Δ	R522	QRD14CJ-100S	10 1/4W UNF. CARBON	
	R529	QRD167J-103	10K 1/6W CARBON	
	R530	QRD167J-154	150K 1/6W CARBON RES	IS
	R531	QRD161J-303Y	30K 1/6W CARBON RES	IS
Δ	R532	QR20077-100	10 1/4W FUSIBLE RE	SI
Δ	R533	QRD14CJ-222S	2.2K 1/4W UNF. CARBON	
Δ	R534	QRD14CJ-222S	2.2K 1/4W UNF. CARBON	
	R536	QRD167J-472	4.7K 1/6W CARBON RES	IS
	R537	QRD167J-104	100K 1/6W CARBON	
	R538	QRD167J-104	100K 1/6W CARBON	
	R539	QRD167J-103	10K 1/6W CARBON	
	R540	QRD167J-104	100K 1/6W CARBON	
	R541	QRD167J-103	10K 1/6W CARBON	
	R542	QRD167J-222	2.2K 1/6W CARBON	
	R543	QRD167J-823	82K 1/6W CARBON RES	IS
	R544	QRD167J-104	100K 1/6W CARBON	
Δ	R545	QRG022J-471AM	470 2W OXIDE METAL	L
	R546	QRD167J-152	1.5K 1/6W CARBON RES	IS
	R551	QRD167J-332	3.3K 1/6W CARBON RES	IS
	R552	QRD167J-392	3.9K 1/6W CARBON RES	IS
	R553	QRD167J-472	4.7K 1/6W CARBON RES	IS
	R554	QRD167J-472	4.7K 1/6W CARBON RES	IS
	R555	QRD167J-472	4.7K 1/6W CARBON RES	IS
	R556	QRD167J-153	15K 1/6W CARBON RES	IS
	R557	QRD167J-103	10K 1/6W CARBON	
	R558	QRD167J-332	3.3K 1/6W CARBON RES	IS
	R559	QRD167J-222	2.2K 1/6W CARBON	
	R572	QRD167J-103	10K 1/6W CARBON	
	R573	QRD167J-102	1K 1/6W CARBON RES	IS
	R574	QRD167J-103	10K 1/6W CARBON	
	R575	QRD167J-103	10K 1/6W CARBON	
	R576	QRD167J-562	5.6K 1/6W CARBON RES	IS
Δ	R577	QRD14CJ-4R7S	4.7 1/4W UNF. CARBON	R
	R581	QRD12CJ-2R7SX	2.7 1/2W CARBON RES	IS
	R582	QRD12CJ-2R7SX	2.7 1/2W CARBON RES	IS
Δ	R591	QRD14CJ-222S	2.2K 1/4W UNF. CARBON	
Δ	R592	QR20077-100	10 1/4W FUSIBLE RE	SI
	R595	QRD167J-104	100K 1/6W CARBON	U
	R595	QRD167J-104	100K 1/6W CARBON	UC
	R595	QRD167J-104	100K 1/6W CARBON	US
	R595	QRD167J-104	100K 1/6W CARBON	UT
	R596	QRD167J-104	100K 1/6W CARBON	U
	R596	QRD167J-104	100K 1/6W CARBON	UC
	R596	QRD167J-104	100K 1/6W CARBON	US
	R596	QRD167J-104	100K 1/6W CARBON	UT
	R597	QRD167J-104	100K 1/6W CARBON	U
	R597	QRD167J-104	100K 1/6W CARBON	UC
	R597	QRD167J-104	100K 1/6W CARBON	US
	R597	QRD167J-104	100K 1/6W CARBON	UT
	R871	QRD167J-102	1K 1/6W CARBON RES	IS
	R872	QRD167J-103	10K 1/6W CARBON	
	R873	QRD167J-471	470 1/6W CARBON RES	IS A
	R873	QRD167J-471	470 1/6W CARBON RES	IS BS
	R873	QRD167J-471	470 1/6W CARBON RES	IS EF
	R873	QRD167J-471	470 1/6W CARBON RES	IS EN
	R873	QRD167J-471	470 1/6W CARBON RES	IS G
	R873	QRD167J-471	470 1/6W CARBON RES	IS GI
	R873	QRD167J-471	470 1/6W CARBON RES	IS VX
	R874	QRD167J-104	100K 1/6W CARBON	A
	R874	QRD167J-104	100K 1/6W CARBON	BS
	R874	QRD167J-104	100K 1/6W CARBON	EF
	R874	QRD167J-104	100K 1/6W CARBON	EN
	R874	QRD167J-104	100K 1/6W CARBON	G
	R874	QRD167J-104	100K 1/6W CARBON	GI
	R874	QRD167J-104	100K 1/6W CARBON	VX
	R875	QRD161J-681	680 1/6W CARBON RES	IS A
	R875	QRD161J-681	680 1/6W CARBON RES	IS BS
	R875	QRD161J-681	680 1/6W CARBON RES	IS EF
	R875	QRD161J-681	680 1/6W CARBON RES	IS EN
	R875	QRD161J-681	680 1/6W CARBON RES	IS G
	R875	QRD161J-681	680 1/6W CARBON RES	IS GI
	R875	QRD161J-681	680 1/6W CARBON RES	IS VX
	R876	QRD167J-104	100K 1/6W CARBON	
	R878	QRD167J-104	100K 1/6W CARBON	U
	R878	QRD167J-104	100K 1/6W CARBON	UC
	R878	QRD167J-104	100K 1/6W CARBON	US
	R878	QRD167J-104	100K 1/6W CARBON	UT
	R879	QRD161J-203	20K 1/6W CARBON RES	IS U
	R879	QRD161J-203	20K 1/6W CARBON RES	IS UC
	R879	QRD161J-203	20K 1/6W CARBON RES	IS US
	R879	QRD161J-203	20K 1/6W CARBON RES	IS UT
	R880	QRD161J-221	220 1/6W CARBON RES	IS A
	R880	QRD161J-221	220 1/6W CARBON RES	IS BS
	R880	QRD161J-221	220 1/6W CARBON RES	IS EF
	R880	QRD161J-221	220 1/6W CARBON RES	IS EN
	R880	QRD161J-221	220 1/6W CARBON RES	IS G
	R880	QRD161J-221	220 1/6W CARBON RES	IS GI
Δ	R880	QRD14CJ-220S	22 1/4W UNF. CARBON	R U
Δ	R880	QRD14CJ-220S	22 1/4W UNF. CARBON	R UC
Δ	R880	QRD14CJ-220S	22 1/4W UNF. CARBON	R US
Δ	R880	QRD14CJ-220S	22 1/4W UNF. CARBON	R UT
	R880	QRD161J-221	220 1/6W CARBON RES	IS VX
	R890	QRD161J-681	680 1/6W CARBON RES	IS
	R891	QRD161J-681	680 1/6W CARBON RES	IS
	R892	QRD161J-681	680 1/6W CARBON RES	IS
	R893	QRD161J-681	680 1/6W CARBON RES	IS

Others

Δ	ITEM	PART NUMBER	DESCRIPTION	AREA
	J511	QWE882-24RR	VINYL WIRE	US
	J512	EMV7125-008R	MALE CONNECTOR 8PIN	
	J521	EMV5109-003B	CONNECT TERMINAL 3PIN	
	J521	EMV7125-011R	MALE CONNECTOR 11	
	J531	EMV7122-005	MALE CONNECTOR 5	
	J541	EMB90TV-402A	SPEAKER TERMINAL	
	J871	VMJ4024-001	HEADPHONE JACK	
	J872	VMJ4024-001	HEADPHONE JACK	
	J911	EMV7122-005	MALE CONNECTOR 10	
	L501	EQL0011-R45J1	INDUCTOR	
	L502	EQL0011-R45J1	INDUCTOR	
	P204	EMV5125-006	CONNECT TERMINAL 6	
	P511	EMV5125-008	MALE CONNECTOR 8	
	P521	EMV5125-011	MALE CONNECTOR 11	
Δ	S001	QSR0085-018	SELECT SWITCH	U
Δ	S001	QSR0085-018	SELECT SWITCH	UC
Δ	S001	QSR0085-018	SELECT SWITCH	US
Δ	S001	QSR0085-018	SELECT SWITCH	UT
	EP501	EMZ4002-001	EARTH PLATE	
	FT001	VMZ0087-001Z	FUSE HOLDER	
	FT002	VMZ0087-001Z	FUSE HOLDER	
	FT003	VMZ0087-001Z	FUSE HOLDER	
	FT004	VMZ0087-001Z	FUSE HOLDER	
	FT005	VMZ0087-001Z	FUSE HOLDER	
	FT006	VMZ0087-001Z	FUSE HOLDER	
	FT007	VMZ0087-001Z	FUSE HOLDER	U
	FT007	VMZ0087-001Z	FUSE HOLDER	UC
	FT007	VMZ0087-001Z	FUSE HOLDER	US
	FT007	VMZ0087-001Z	FUSE HOLDER	UT
	FT008	VMZ0087-001Z	FUSE HOLDER	U
	FT008	VMZ0087-001Z	FUSE HOLDER	UC
	FT008	VMZ0087-001Z	FUSE HOLDER	US
	FT008	VMZ0087-001Z	FUSE HOLDER	UT
	FW501	EWR39E-10LS	FLAT WIRE ASSY 9	
	FW502	EWR35D-08SS	FLAT WIRE ASSY 5	
	FW531	EWR35D-25LS	FLAT WIRE ASSY 5	
	FW601	EWR37D-20LS	FLAT WIRE ASSY 7	
	FW998	EWR34D-20LS	FLAT WIRE ASSY 4	U
	FW998	EWR34D-20LS	FLAT WIRE ASSY 4	UC
	FW998	EWR34D-20LS	FLAT WIRE ASSY 4	US
	FW998	EWR34D-20LS	FLAT WIRE ASSY 4	UT
	JB803	EMV5122-006R	CONNECT TERMINAL 6	
	JT501	EMV7122-004	CONNECT TERMINAL	
	JT502	EMV7122-005	MALE CONNECTOR	
	RY501	ESK7D24-2120	RELAY	
	TB001	EMZ4001-001	TAB	
	TB002	EMZ4001-001	TAB	

Δ IS SAFETY PARTS.

■ FSJ-001 □ Deck PC Board Ass'y

Note: FSJ-001 □ varies according to the areas employed. See note (1) when placing an order.

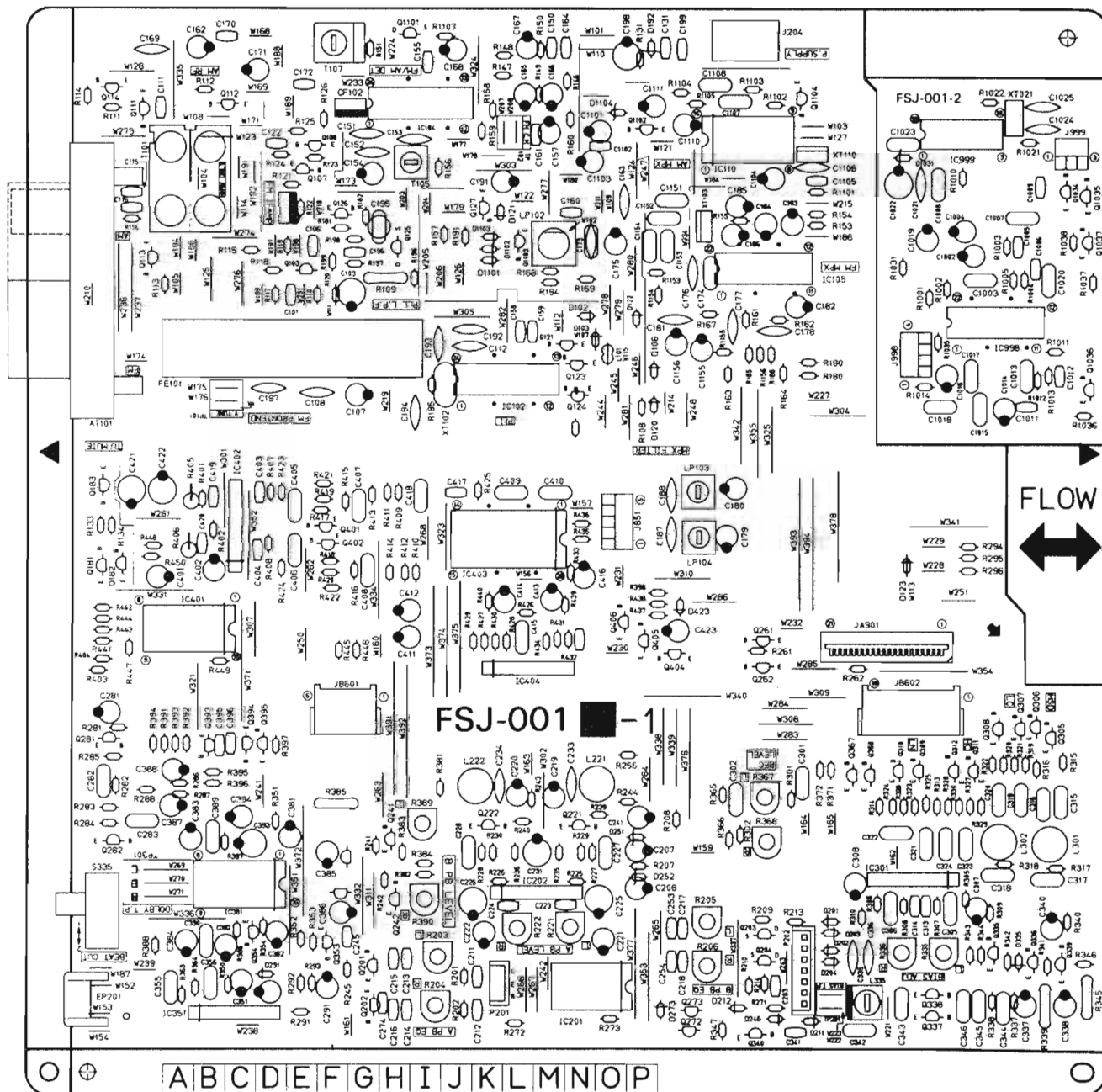

Note (1)

PC Board Ass'y	Version	Designated Areas
FSJ-001	H	U UC US UT
FSJ-001	I	A
FSJ-001	J	EN EF

FSJ-001	K	G	Germany
FSJ-001	L	BS	the U.K.
FSJ-001	M	GI	Italy
FSJ-001	N	VX	East Europe
FSJ-001	O	J C	the U.S.A Canada

Δ	ITEM	PART NUMBER	DESCRIPTION	AREA
	R1031	QRD161J-221	220 1/6W CARBON RES	IS UC
	R1031	QRD161J-221	220 1/6W CARBON RES	IS US
	R1031	QRD161J-221	220 1/6W CARBON RES	IS UT
	R1035	QRD161J-303Y	30K 1/6W CARBON RES	IS U
	R1035	QRD161J-303Y	30K 1/6W CARBON RES	IS UC
	R1035	QRD161J-303Y	30K 1/6W CARBON RES	IS US
	R1035	QRD161J-303Y	30K 1/6W CARBON RES	IS UT
	R1036	QRD167J-563	56K 1/6W CARBON RES	IS U
	R1036	QRD167J-563	56K 1/6W CARBON RES	IS UC
	R1036	QRD167J-563	56K 1/6W CARBON RES	IS US
	R1036	QRD167J-563	56K 1/6W CARBON RES	IS UT
	R1037	QRD167J-243	24K 1/6W CARBON	U
	R1037	QRD167J-243	24K 1/6W CARBON	UC
	R1037	QRD167J-243	24K 1/6W CARBON	US
	R1037	QRD167J-243	24K 1/6W CARBON	UT
	R1038	QRD167J-123	12K 1/6W CARBON	U
	R1038	QRD167J-123	12K 1/6W CARBON	UC
	R1038	QRD167J-123	12K 1/6W CARBON	US
	R1038	QRD167J-123	12K 1/6W CARBON	UT

Δ ISIAFETY PARTS

Others

Δ	ITEM	PART NUMBER	DESCRIPTION	AREA
	J204	EMV7125-006R	CONNECT TERMINAL 6PIN	
	J851	EMV7122-005	MALE CONNECTORS	
	J998	EMV7122-004	CONNECT TERMINAL 4	U
	J998	EMV7122-004	CONNECT TERMINAL 4	UC
	J998	EMV7122-004	CONNECT TERMINAL 4	US
	J998	EMV7122-004	CONNECT TERMINAL 4	UT
	J999	EMV7122-103	CONNECT TERMINAL 3	U
	J999	EMV7122-103	CONNECT TERMINAL 3	UC
	J999	EMV7122-103	CONNECT TERMINAL 3	US
	J999	EMV7122-103	CONNECT TERMINAL 3	UT
	L101	EQL4007-1R0T	INDUCTOR	
	L102	EQL4007-2R2T	INDUCTOR	
	L221	EQL2106-223	INDUCTOR	
	L222	EQL2106-223	INDUCTOR	
	L301	EQL2106-562	INDUCTOR	
	L302	EQL2106-562	INDUCTOR	
	L335	ENZ6002-013J2	OSC COIL	
	P201	EMV5133-003K	CONNECT TERMINAL 3	
	P202	EMV5133-007K	PLUG 7	
	S335	QSS7A12-E01	SLIDE SWITCH	BS
	S335	QSS7A12-E01	SLIDE SWITCH	EF
	S335	QSS7A12-E01	SLIDE SWITCH	EN
	S335	QSS7A12-E01	SLIDE SWITCH	G
	S335	QSS7A12-E01	SLIDE SWITCH	GI
	S335	QSS7A12-E01	SLIDE SWITCH	VX
	T101	EQR7121-004	RF COIL	A
	T101	EQR7121-002	RF COIL	BS
	T101	EQR7121-004	RF COIL	C
	T101	EQR7121-002	RF COIL	EF
	T101	EQR7121-002	RF COIL	EN
	T101	EQR7121-002	RF COIL	G
	T101	EQR7121-002	RF COIL	GI
	T101	EQR7121-004	RF COIL	J
	T101	EQR7121-004	RF COIL	U
	T101	EQR7121-004	RF COIL	UC
	T101	EQR7121-004	RF COIL	US
	T101	EQR7121-004	RF COIL	UT
	T101	EQR7121-002	RF COIL	VX
	T105	EQT2140-017	I.F. TRANSFORMER	
	T107	ECB1560-010	CERAMIC FILTER	
	AT101	EMB41YV-302K	ANTENNA TERMINAL	
	CF101	ECB2123-006R	CERAMIC FILTER	A
	CF101	ECB2118-007R	CERAMIC FILTER	BS
	CF101	ECB2123-006R	CERAMIC FILTER	C
	CF101	ECB2118-007R	CERAMIC FILTER	EF
	CF101	ECB2118-007R	CERAMIC FILTER	EN
	CF101	ECB2118-007R	CERAMIC FILTER	G
	CF101	ECB2118-007R	CERAMIC FILTER	GI
	CF101	ECB2123-006R	CERAMIC FILTER	J
	CF101	ECB2123-006R	CERAMIC FILTER	U
	CF101	ECB2123-006R	CERAMIC FILTER	UC
	CF101	ECB2123-006R	CERAMIC FILTER	US
	CF101	ECB2123-006R	CERAMIC FILTER	UT
	CF101	ECB2118-007R	CERAMIC FILTER	VX
	CF102	ECB2123-006R	CERAMIC FILTER	A
	CF102	ECB2118-007R	CERAMIC FILTER	BS
	CF102	ECB2123-006R	CERAMIC FILTER	C
	CF102	ECB2118-007R	CERAMIC FILTER	EF
	CF102	ECB2118-007R	CERAMIC FILTER	EN
	CF102	ECB2118-007R	CERAMIC FILTER	G
	CF102	ECB2118-007R	CERAMIC FILTER	GI
	CF102	ECB2123-006R	CERAMIC FILTER	J
	CF102	ECB2123-006R	CERAMIC FILTER	U
	CF102	ECB2123-006R	CERAMIC FILTER	UC
	CF102	ECB2123-006R	CERAMIC FILTER	US
	CF102	ECB2123-006R	CERAMIC FILTER	UT
	CF102	ECB2118-007R	CERAMIC FILTER	VX
	EP201	E70225-003SS	EARTH PLATE	
	FE101	EAF2203-004	FRONT END	A
	FE101	EAF2203-004	FRONT END	BS

Δ ISIAFETY PARTS

Others

Δ	ITEM	PART NUMBER	DESCRIPTION	AREA
	FE101	EAF2203-004	FRONT END	C
	FE101	EAF2203-004	FRONT END	EF
	FE101	EAF2203-004	FRONT END	EN
	FE101	EAF2203-005	FRONT END	G
	FE101	EAF2203-005	FRONT END	GI
	FE101	EAF2203-004	FRONT END	J
	FE101	EAF2203-004	FRONT END	U
	FE101	EAF2203-004	FRONT END	UC
	FE101	EAF2203-004	FRONT END	US
	FE101	EAF2203-004	FRONT END	UT
	FE101	EAF2302-002	FRONT END	VX
	JA901	VMC0163-021	CONNECT TERMINAL 21PIN	
	JB601	VMC0193-P06	CONNECT TERMINAL 6	
	JB602	VMC0193-P10	CONNECT TERMINAL 10	
	LP102	EQF0102-001	LOWPASS FILTER	G
	LP102	EQF0102-001	LOWPASS FILTER	GI
	LP103	EQF0101-010J2	LOW PASS FILTER	
	LP104	EQF0101-010J2	LOW PASS FILTER	
	XT021	ECX0000-400KS	CERAMIC RESONATOR	U
	XT021	ECX0000-400KS	CERAMIC RESONATOR	UC
	XT021	ECX0000-400KS	CERAMIC RESONATOR	US
	XT021	ECX0000-400KS	CERAMIC RESONATOR	UT
	XT102	ECX0007-200KWJ1	CRYSTAL	
	XT103	ECX0000-456KR	CERAMIC RESONATOR	

Δ ISIAFETY PARTS

CA-S20BK

■ FSN-009 □ CD & Deck Switch PC Board Ass'y

Note: FSN-009 □ varies according to the areas employed. See note (1) when placing an order.

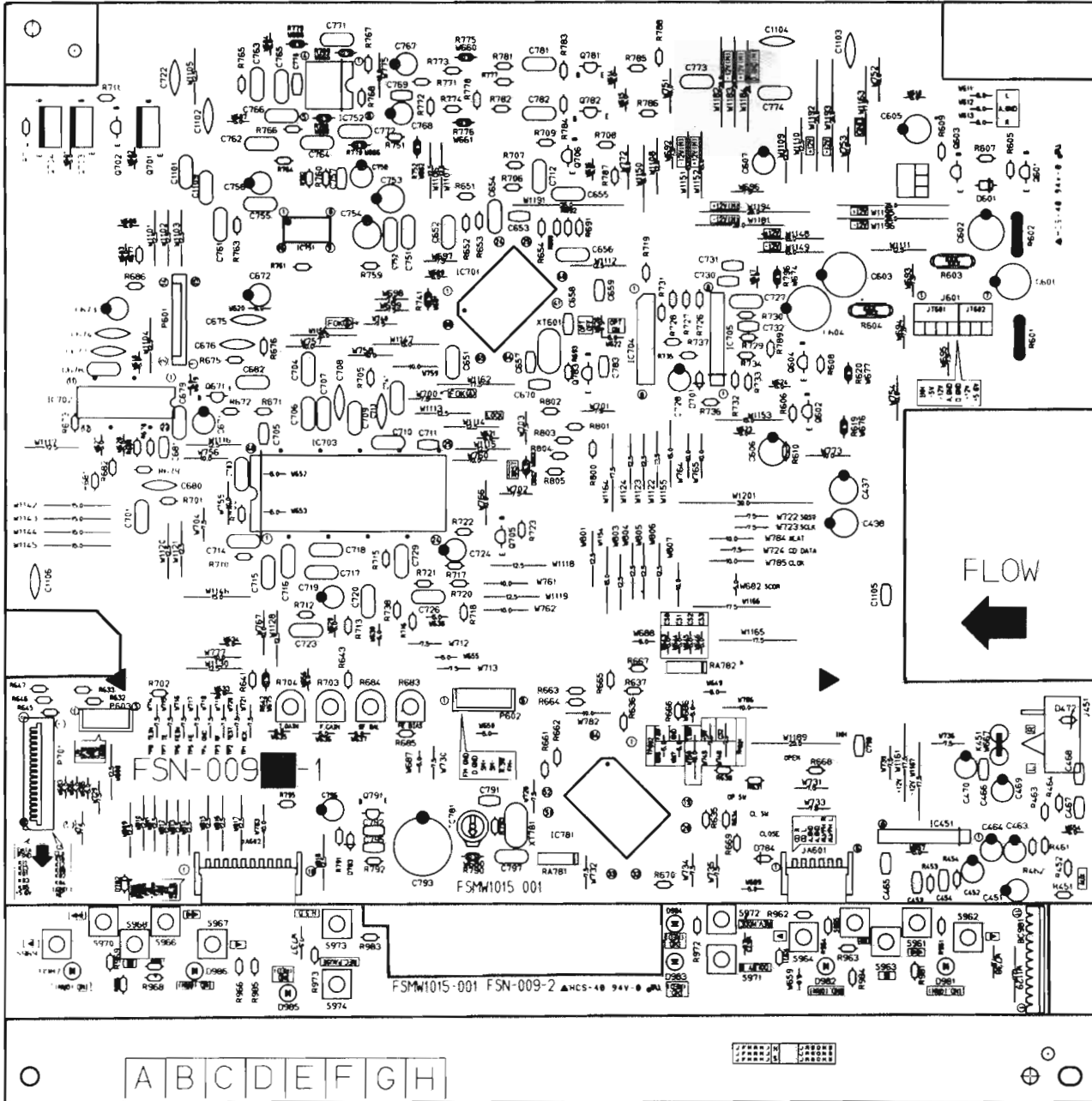

Note (1)

PC Board Ass'y	Version	Designated Areas
FSN-009 A	U UC US UT	Universal Type China Singapore Taiwan
FSN-009 B	A	Australia
FSN-009 C	EN EF	Scandinavia Continental Europe

FSN-009 D	G	Germany
FSN-009 E	BS	the U.K.
FSN-009 F	GI	Italy
FSN-009 G	VX	East Europe
FSN-009 H	J C	the U.S.A Canada

Transistors

Δ	ITEM	PART NUMBER	DESCRIPTION	AREA
	Q601	2SA934(Q,R)	SI.TRANSISTROHM	
	Q602	2SC3311A(Q,R)	SI.TRANSISTMATSUSHITA	
	Q603	BA1L4M	DIGITAL TRA	
	Q604	BN1L4L	DIGITAL TRANEC	
	Q671	2SA934(Q,R)	SI.TRANSISTROHM	
	Q701	2SD2037(E,F)	SI.TRANSISTROHM	
	Q702	2SA934(Q,R)	SI.TRANSISTROHM	
	Q703	2SD2037(E,F)	SI.TRANSISTROHM	
	Q704	2SB1357(E,F)	SI.TRANSISTROHM	
	Q705	BA1L4M	DIGITAL TRA	
	Q706	2SC3311A(Q,R)	SI.TRANSISTMATSUSHITA	
	Q781	2SC3311A(Q,R)	SI.TRANSISTMATSUSHITA	
	Q782	2SC3311A(Q,R)	SI.TRANSISTMATSUSHITA	
	Q783	BN1L4M	DIGITAL TRA	
	Q791	BA1A4P	DIGITAL TRANEC	

Δ ISIAFETY PARTS.

I.C.s

Δ	ITEM	PART NUMBER	DESCRIPTION	AREA
	IC451	NJM4580LD	I.C(MONO-ANDAINICHI	
	IC701	CXD2500BQ	I.C(DIGI-M01680	
	IC702	CXA1571S	I.C(MONO-AN1680	
	IC703	CXA1372S	I.C(MONO-AN1680	
	IC704	STA341M(A)	TRANSISTOR	
	IC705	NJM4580L-S	I.C(MONO-AN0050	
	IC751	UPD6376CX	I.C(DIGI-MONEC	
	IC752	BA15218	I.C(MONO-ANROHM	

Δ ISIAFETY PARTS.

Diodes

Δ	ITEM	PART NUMBER	DESCRIPTION	AREA
	D601	1SR139-200	SI.DIODE ROHM	
	D701	1SS119	SI.DIODE	
	D782	1SS119	SI.DIODE	
	D783	1SS119	SI.DIODE	
	D784	1SS119	SI.DIODE	
	D981	SLR-342MCA47	L.E.D. ROHM	
	D982	SLR-342MCA47	L.E.D. ROHM	
	D983	SLR-342VC3F	L.E.D. ROHM	
	D984	SLR-342VC3F	L.E.D. ROHM	
	D985	SLR-342VC3F	L.E.D. ROHM	
	D986	SLR-342MCA47	L.E.D. ROHM	
	D987	SLR-342MCA47	L.E.D. ROHM	

Δ ISIAFETY PARTS.

Capacitors

Δ	ITEM	PART NUMBER	DESCRIPTION	AREA
	C451	QETB1HM-475E	4.7MF 50V E.CAPACITO R	
	C452	QETB1HM-475E	4.7MF 50V E.CAPACITO R	
	C453	QCBB1HK-471Y	470PF 50V CER.CAPACI TO	
	C454	QCBB1HK-471Y	470PF 50V CER.CAPACI TO	
	C463	QETB1HM-475E	4.7MF 50V E.CAPACITO R	
	C464	QETB1HM-475E	4.7MF 50V E.CAPACITO R	
	C467	QCBB1HK-331Y	330PF 50V CER.CAPACI TO	
	C468	QCBB1HK-331Y	330PF 50V CER.CAPACI TO	
	C469	QETB1EM-476	47MF 25V AL E.CAPAC IT	
	C470	QETB1EM-476	47MF 25V AL E.CAPAC IT	
	C601	QETB1CM-227	220MF 16V AL E.CAPAC IT	
	C602	QETB1CM-227	220MF 16V AL E.CAPAC IT	
	C603	QETB1CM-108	1000MF 16V AL E.CAPAC IT	
	C604	QETB1CM-108	1000MF 16V AL E.CAPAC IT	
	C605	QETB0JM-227	220MF 6.3V E.CAPACITO R	
	C606	QETB0JM-107	100MF 6.3V AL E.CAPAC IT	
	C607	QETB1HM-105	1MF 50V AL E.CAPAC IT	
	C651	QCZ0202-155	1.5MF 25V CER.RESIST DR	
	C652	QFLB1HJ-473	0.047MF 50V MYLAR CAPA CI	
	C653	QCHB1EZ-223	0.022MF 25V CER.CAPACI TO	
	C654	QFLB1HJ-152	1500PF 50V MYLAR CAPA CI	
	C655	QFLB1HJ-102	1000PF 50V MYLAR CAPA CI	
	C656	QCZ0202-155	1.5MF 25V CER.RESIST DR	
	C657	QCT30CH-100Y	10PF 50V CER.CAPACI TO	
	C658	QCT30CH-100Y	10PF 50V CER.CAPACI TO	
	C671	QETB1AM-107	100MF 10V AL E.CAPAC IT	
	C673	QETB1AM-476	47MF 10V E.CAPACITO R	
	C674	QCS21HJ-100	10PF 50V CER.CAPACI TO	
	C675	QCS21HJ-820	82PF 50V CER.CAPACI TO	
	C676	QCS21HJ-101A	100PF 50V CER.CAPACI TO	
	C677	QCS21HJ-100	10PF 50V CER.CAPACI TO	
	C678	QCZ0202-155	1.5MF 25V CER.RESIST DR	
	C679	QCZ0202-155	1.5MF 25V CER.RESIST DR	
	C680	QCS21HJ-220	22PF 50V CER.CAPACI TO	
	C681	QCHB1EZ-223	0.022MF 25V CER.CAPACI TO	
	C701	QFLB1HJ-122	1200PF 50V MYLAR CAPA CI	
	C703	QFLB1HJ-222	2200PF 50V MYLAR CAPA CI	
	C704	QFLB1HJ-222	2200PF 50V MYLAR CAPA CI	
	C705	QCHB1EZ-223	0.022MF 25V CER.CAPACI TO	
	C706	QFLB1HJ-333	0.033MF 50V MYLAR CAPA CI	

Δ ISIAFETY PARTS.

Capacitors

Δ	ITEM	PART NUMBER	DESCRIPTION	AREA
	C707	QFLB1HJ-103	0.01MF 50V MYLAR CAPA CI	
	C708	QCF21HP-223A	0.022MF 50V CER.CAPACI TO	
	C709	QFLB1HJ-333	0.033MF 50V MYLAR CAPA CI	
	C710	QCZ0202-155	1.5MF 25V CER.RESIST DR	
	C711	QCHB1EZ-223	0.022MF 25V CER.CAPACI TO	
	C712	QFLB1HJ-104	0.1MF 50V MYLAR CAPA CI	
	C713	QCS31HJ-471Z	470PF 50V CER.CAPACI TO	
	C714	QFLB1HJ-104	0.1MF 50V MYLAR CAPA CI	
	C715	QFLB1HJ-333	0.033MF 50V MYLAR CAPA CI	
	C716	QFLB1HJ-473	0.047MF 50V MYLAR CAPA CI	
	C717	QFLB1HJ-473	0.047MF 50V MYLAR CAPA CI	
	C718	QFLB1HJ-473	0.047MF 50V MYLAR CAPA CI	
	C719	QETB1HM-106	10MF 50V E.CAPACITO R	
	C720	QFLB1HJ-104	0.1MF 50V MYLAR CAPA CI	
	C722	QCF21HP-223A	0.022MF 50V CER.CAPACI TO	
	C723	QFLB1HJ-333	0.033MF 50V MYLAR CAPA CI	
	C724	QETB1HM-106	10MF 50V E.CAPACITO R	
	C726	QFLB1HJ-223	0.022MF 50V MYLAR CAPA CI	
	C727	QFLB1HJ-103	0.01MF 50V MYLAR CAPA CI	
	C728	QETB1HM-475E	4.7MF 50V E.CAPACITO R	
	C729	QFLB1HJ-393	0.039MF 50V MYLAR CAPA CI	
	C730	QCHB1EZ-223	0.022MF 25V CER.CAPACI TO	
	C731	QCHB1EZ-223	0.022MF 25V CER.CAPACI TO	
	C732	QCBB1HK-681Y	680PF 50V CER.CAPACI TO	
	C741	QFLB1HJ-153	0.015MF 50V MYLAR CAPA CI	
	C751	QFLB1HJ-104	0.1MF 50V MYLAR CAPA CI	
	C752	QFLB1HJ-104	0.1MF 50V MYLAR CAPA CI	
	C753	QETB1EM-107	100MF 25V AL E.CAPAC IT	
	C754	QETB1EM-107	100MF 25V AL E.CAPAC IT	
	C755	QCZ0202-155	1.5MF 25V CER.RESIST DR	
	C756	QETB1HM-476	47MF 50V E.CAPACITO R	
	C757	QCHB1EZ-223	0.022MF 25V CER.CAPACI TO	
	C761	QFLB1HJ-562	5600PF 50V MYLAR CAPA CI	
	C762	QFLB1HJ-562	5600PF 50V MYLAR CAPA CI	
	C763	QFLB1HJ-153	0.015MF 50V MYLAR CAPA CI	
	C764	QFLB1HJ-153	0.015MF 50V MYLAR CAPA CI	
	C765	QFLB1HJ-821	820PF 50V MYLAR CAPA CI	
	C766	QFLB1HJ-821	820PF 50V MYLAR CAPA CI	
	C767	EET2502-476N	47MF AL E.CAPAC IT	
	C768	EET2502-476N	47MF AL E.CAPAC IT	
	C769	QCHB1EZ-223	0.022MF 25V CER.CAPACI TO	
	C770	QCHB1EZ-223	0.022MF 25V CER.CAPACI TO	
	C771	QFLB1HJ-104	0.1MF 50V MYLAR CAPA CI	
	C772	QFLB1HJ-104	0.1MF 50V MYLAR CAPA CI	
	C781	QFLB1HJ-683	0.068MF 50V MYLAR CAPA CI	
	C782	QFLB1HJ-683	0.068MF 50V MYLAR CAPA CI	
	C783	QCVB1CM-103Y	0.01MF 16V CER.CAPACI TO	
	C791	QCT30CH-150Y	15PF 50V CER.CAPACI TO	
	C792	QCVB1CM-103Y	0.01MF 16V CER.CAPACI TO	
	C793	QEA40HZ-10AB	E.CAPACITO R	
	C795	QCVB1CM-103Y	0.01MF 16V CER.CAPACI TO	
	C796	QETB1HM-475E	4.7MF 50V E.CAPACITO R	
	C797	QCZ0202-155	1.5MF 25V CER.RESIST DR	
	C798	QCVB1CM-103Y	0.01MF 16V CER.CAPACI TO	
	C1101	QCZ0202-155	1.5MF 25V CER.RESIST DR	

Δ ISIAFETY PARTS.

Resistors

Δ	ITEM	PART NUMBER	DESCRIPTION	AREA
	R451	QRD167J-222	2.2K 1/6W CARBON	
	R452	QRD167J-222	2.2K 1/6W CARBON	
	R453	QRD167J-473	47K 1/6W CARBON RES IS	
	R454	QRD167J-473	47K 1/6W CARBON RES IS	
	R461	QRD167J-152	1.5K 1/6W CARBON RES IS	
	R462	QRD167J-152	1.5K 1/6W CARBON RES IS	
	R463	QRD161J-302	3K 1/6W CARBON RES IS	
	R464	QRD161J-302	3K 1/6W CARBON RES IS	
	R601	QRZ0077-100	10 1/4W FUSIBLE RE SI	
	R602	QRZ0077-100	10 1/4W FUSIBLE RE SI	
	R603	QRD14CJ-4R7S	4.7 1/4W UNF.CARBON R	
	R604	QRD14CJ-4R7S	4.7 1/4W UNF.CARBON R	
	R605	QRD167J-472	4.7K 1/6W CARBON RES IS	
	R606	QRD167J-472	4.7K 1/6W CARBON RES IS	
	R607	QRD167J-471	470 1/6W CARBON RES IS	
	R608	QRD167J-182	1.8K 1/6W CARBON	
	R609	QRD167J-103	10K 1/6W CARBON	
	R610	QRD167J-472	4.7K 1/6W CARBON RES IS	
	R631	QRD167J-103	10K 1/6W CARBON	
	R632	QRD167J-103	10K 1/6W CARBON	
	R633	QRD167J-103	10K 1/6W CARBON	
	R635	QRD167J-103	10K 1/6W CARBON	
	R641	QRD167J-103	10K 1/6W CARBON	
	R642	QRD167J-822	8.2K 1/6W CARBON RES IS	
	R643	QRD167J-123	12K 1/6W CARBON	
	R651	QRD167J-332	3.3K 1/6W CARBON RES IS	
	R652	QRD167J-682	6.8K 1/6W CARBON RES IS	
	R653	QRD167J-103	10K 1/6W CARBON	
	R654	QRD167J-103	10K 1/6W CARBON	
	R661	QRD167J-103	10K 1/6W CARBON	
	R662	QRD167J-103	10K 1/6W CARBON	
	R663	QRD167J-103	10K 1/6W CARBON	
	R664	QRD167J-563	56K 1/6W CARBON RES IS	
	R665	QRD167J-563	56K 1/6W CARBON RES IS	
	R666	QRD167J-103	10K 1/6W CARBON	

Δ ISIAFETY PARTS.

Transistors

Δ	ITEM	PART NUMBER	DESCRIPTION	AREA
	Q841	DTA144EFF	DIGITAL TRAROHM	U
	Q841	DTA144EFF	DIGITAL TRAROHM	UC
	Q841	DTA144EFF	DIGITAL TRAROHM	US
	Q841	DTA144EFF	DIGITAL TRAROHM	UT
	Q842	DTA144EFF	DIGITAL TRAROHM	U
	Q842	DTA144EFF	DIGITAL TRAROHM	UC
	Q842	DTA144EFF	DIGITAL TRAROHM	US
	Q842	DTA144EFF	DIGITAL TRAROHM	UT
	Q843	DTA144EFF	DIGITAL TRAROHM	U
	Q843	DTA144EFF	DIGITAL TRAROHM	UC
	Q843	DTA144EFF	DIGITAL TRAROHM	US
	Q843	DTA144EFF	DIGITAL TRAROHM	UT
	Q844	DTA144EFF	DIGITAL TRAROHM	U
	Q844	DTA144EFF	DIGITAL TRAROHM	UC
	Q844	DTA144EFF	DIGITAL TRAROHM	US
	Q844	DTA144EFF	DIGITAL TRAROHM	UT
	Q851	2SD2144S(VW)	SI. TRANSISTROHM	
	Q852	2SD2144S(VW)	SI. TRANSISTROHM	
	Q853	BA1L4M	DIGITAL TRA	
	Q862	2SC3311A(Q,R)	SI. TRANSISTMATSUSHITA	
	Q931	BA1L4M	DIGITAL TRA	
	Q932	BA1L4M	DIGITAL TRA	
	Q941	2SC3311A(Q,R)	SI. TRANSISTMATSUSHITA	
	Q942	2SC3311A(Q,R)	SI. TRANSISTMATSUSHITA	
	Q943	2SA1175(CHFE)	SI. TRANSIST	
	Q944	2SA1175(CHFE)	SI. TRANSIST	

Δ : SAFETY PARTS

Capacitors

Δ	ITEM	PART NUMBER	DESCRIPTION	AREA
	C855	QER51HM-474G	0.47MF 50V AL E.CAPAC	IT
	C856	QER51HM-474G	0.47MF 50V AL E.CAPAC	IT
	C857	QER51EM-106	10MF 25V E.CAPACITO	R
	C858	QER51EM-106	10MF 25V E.CAPACITO	R
	C863	QER51HM-475	4.7MF 50V AL E.CAPAC	IT
	C867	QCVB1CM-103Y	0.01MF 16V CER.CAPACI	TO
	C869	QER51HM-475	4.7MF 50V AL E.CAPAC	IT
	C870	QER51HM-475	4.7MF 50V AL E.CAPAC	IT
	C901	QCVB1CM-103Y	0.01MF 16V CER.CAPACI	TO
	C902	QETB1AM-107	100MF 10V AL E.CAPAC	IT
	C905	QCBB1HK-561Y	560PF 50V CER.CAPACI	TO
	C907	QCVB1CM-103Y	0.01MF 16V CER.CAPACI	TO U
	C907	QCVB1CM-103Y	0.01MF 16V CER.CAPACI	TO UC
	C907	QCVB1CM-103Y	0.01MF 16V CER.CAPACI	TO US
	C907	QCVB1CM-103Y	0.01MF 16V CER.CAPACI	TO UT
	C909	QETB1AM-476	47MF 10V E.CAPACITO	R
	C921	QCVB1CM-103Y	0.01MF 16V CER.CAPACI	TO
	C922	QCVB1CM-103Y	0.01MF 16V CER.CAPACI	TO
	C923	QCVB1CM-103Y	0.01MF 16V CER.CAPACI	TO
	C924	QCVB1CM-103Y	0.01MF 16V CER.CAPACI	TO
	C925	QCHB1EZ-223	0.022MF 25V CER.CAPACI	TO
	C926	QCHB1EZ-223	0.022MF 25V CER.CAPACI	TO
	C927	QCHB1EZ-223	0.022MF 25V CER.CAPACI	TO
	C928	QCHB1EZ-223	0.022MF 25V CER.CAPACI	TO
	C941	QETB1CM-107	100MF 16V AL E.CAPAC	IT
	C942	QETB1EM-106	10MF 25V AL E.CAPAC	IT

Δ : SAFETY PARTS

I.C.s

Δ	ITEM	PART NUMBER	DESCRIPTION	AREA
	IC801	MSC7112-01SS	I.C.(DIGI-MONIHON DENSO	
	IC810	NJH32H380A	I.C.(M) DAINICHI	
	IC851	BA15218N	I.C.(MONO-ANROHM	
	IC901	HD404719A38FS	I.C.(MICRO-CHITACHI	
	IC905	TC74HC595AP	I.C.(DIGI-MOTOSHIBA	
	IC906	TC74HC595AP	I.C.(DIGI-MOTOSHIBA	U
	IC906	TC74HC595AP	I.C.(DIGI-MOTOSHIBA	UC
	IC906	TC74HC595AP	I.C.(DIGI-MOTOSHIBA	US
	IC906	TC74HC595AP	I.C.(DIGI-MOTOSHIBA	UT
	IC909	LB1639-CV	I.C.(DIGI-OTSANYO	
	IC921	LB1641	I.C.(DIGI-OTSANYO	
	IC922	LB1641	I.C.(DIGI-OTSANYO	
	IC923	LB1641	I.C.(DIGI-OTSANYO	
	IC924	LB1641	I.C.(DIGI-OTSANYO	

Δ : SAFETY PARTS

Diodes

Δ	ITEM	PART NUMBER	DESCRIPTION	AREA
	D802	SLR-342MCA47	L.E.D. ROHM	
	D811	SLR-342VC3F	L.E.D. ROHM	
	D811	SLR-342VC3F	L.E.D. ROHM	A
	D811	SLA-380LT	L.E.D. ROHM	BS
	D811	SLR-342VC3F	L.E.D. ROHM	C
	D811	SLR-342VC3F	L.E.D. ROHM	EF
	D811	SLR-342VC3F	L.E.D. ROHM	EN
	D811	SLR-342VC3F	L.E.D. ROHM	G
	D811	SLR-342VC3F	L.E.D. ROHM	GI
	D811	SLR-342VC3F	L.E.D. ROHM	J
	D811	SLR-342VC3F	L.E.D. ROHM	U
	D811	SLR-342VC3F	L.E.D. ROHM	UC
	D811	SLR-342VC3F	L.E.D. ROHM	US
	D811	SLR-342VC3F	L.E.D. ROHM	UT
	D811	SLR-342VC3F	L.E.D. ROHM	VX
	D812	SLR-342MCA47	L.E.D. ROHM	
	D841	1SS119	SI.DIODE	U
	D841	1SS119	SI.DIODE	UC
	D841	1SS119	SI.DIODE	US
	D841	1SS119	SI.DIODE	UT
	D842	1SS119	SI.DIODE	U
	D842	1SS119	SI.DIODE	UC
	D842	1SS119	SI.DIODE	US
	D842	1SS119	SI.DIODE	UT
	D909	1SR139-200	SI.DIODE ROHM	

Δ : SAFETY PARTS

Capacitors

Δ	ITEM	PART NUMBER	DESCRIPTION	AREA
	C801	QCBB1HK-151	150PF 50V CER.CAPACI	TO
	C802	QER50JM-476	47MF 6.3V AL E.CAPAC	IT
	C803	QEK51HM-106	10MF 50V AL E.CAPAC	IT
	C805	QEK51HM-226	22MF 50V AL E.CAPAC	IT
	C806	QEK51HM-226	22MF 50V AL E.CAPAC	IT
	C810	QER50JM-107	100MF 6.3V AL E.CAPAC	IT
	C851	QER51CM-476	47MF 16V AL E.CAPAC	IT
	C852	QER51CM-476	47MF 16V AL E.CAPAC	IT
	C853	QER51HM-104G	0.1MF 50V AL E.CAPAC	IT
	C854	QER51HM-104G	0.1MF 50V AL E.CAPAC	IT

Δ : SAFETY PARTS

Resistors

Δ	ITEM	PART NUMBER	DESCRIPTION	AREA
	R801	QRD167J-563	56K 1/6W CARBON RES	IS
	R810	QRD161J-331	330 1/6W CARBON RES	IS
	R811	QRD161J-331	330 1/6W CARBON RES	IS
	R811	QRD167J-271	270 1/6W CARBON RES	IS A
	R811	QRD167J-471	470 1/6W CARBON RES	IS BS
	R811	QRD167J-271	270 1/6W CARBON RES	IS C
	R811	QRD167J-271	270 1/6W CARBON RES	IS EF
	R811	QRD167J-271	270 1/6W CARBON RES	IS EN
	R811	QRD167J-271	270 1/6W CARBON RES	IS G
	R811	QRD167J-271	270 1/6W CARBON RES	IS GI
	R811	QRD167J-271	270 1/6W CARBON RES	IS J
	R811	QRD167J-271	270 1/6W CARBON RES	IS U
	R811	QRD167J-271	270 1/6W CARBON RES	IS UC
	R811	QRD167J-271	270 1/6W CARBON RES	IS US
	R811	QRD167J-271	270 1/6W CARBON RES	IS UT
	R811	QRD167J-271	270 1/6W CARBON RES	IS VX
	R812	QRD161J-181	180 1/6W CARBON RES	IS
	R831	QRD167J-431	430 1/6W CARBON RES	IS
	R832	QRD161J-681	680 1/6W CARBON RES	IS
	R833	QRD161J-112	1.1K 1/6W CARBON RES	IS
	R834	QRD167J-222	2.2K 1/6W CARBON	IS
	R835	QRD167J-682	6.8K 1/6W CARBON RES	IS
	R837	QRD167J-431	430 1/6W CARBON RES	IS
	R838	QRD161J-681	680 1/6W CARBON RES	IS
	R839	QRD161J-112	1.1K 1/6W CARBON RES	IS
	R841	QRD167J-104	100K 1/6W CARBON	IS
	R842	QRD167J-104	100K 1/6W CARBON	IS
	R843	QRD167J-104	100K 1/6W CARBON	IS
	R851	QRD161J-274	270K 1/6W CARBON RES	IS
	R852	QRD161J-274	270K 1/6W CARBON RES	IS
	R853	QRD167J-511	510 1/6W CARBON RES	IS
	R854	QRD167J-511	510 1/6W CARBON RES	IS
	R855	QRD167J-682	6.8K 1/6W CARBON RES	IS
	R856	QRD167J-682	6.8K 1/6W CARBON RES	IS
	R857	QRD161J-203	20K 1/6W CARBON RES	IS
	R858	QRD161J-203	20K 1/6W CARBON RES	IS
	R859	QRD167J-103	10K 1/6W CARBON	IS
	R860	QRD167J-103	10K 1/6W CARBON	IS
	R861	QRD167J-472	4.7K 1/6W CARBON RES	IS
	R862	QRD167J-392	3.9K 1/6W CARBON RES	IS
	R863	QRD161J-105	1M 1/6W CARBON RES	IS
	R864	QRD167J-222	2.2K 1/6W CARBON	IS
	R865	QRD167J-224	220K 1/6W CARBON	IS
	R866	QRD167J-224	220K 1/6W CARBON	IS
	R867	QVDB94B-E15C	100K VARIABLE R	ES
	R868	QRD161J-301	300 1/6W CARBON RES	IS
	R869	QRD167J-472	4.7K 1/6W CARBON RES	IS
	R870	QRD167J-472	4.7K 1/6W CARBON RES	IS
	R875	QVAA72B-E54B	50K VARIABLE R	ES U
	R875	QVAA72B-E54B	50K VARIABLE R	ES UC
	R875	QVAA72B-E54B	50K VARIABLE R	ES US
	R875	QVAA72B-E54B	50K VARIABLE R	ES UT
	R901	QRD161J-105	1M 1/6W CARBON RES	IS
	R902	QRD167J-223	22K 1/6W CARBON RES	IS
	R905	QRD167J-103	10K 1/6W CARBON	IS
	R906	QRD167J-103	10K 1/6W CARBON	U
	R906	QRD167J-103	10K 1/6W CARBON	UC
	R906	QRD167J-103	10K 1/6W CARBON	US
	R906	QRD167J-103	10K 1/6W CARBON	UT
	R911	QRD167J-103	10K 1/6W CARBON	
	R912	QRD167J-332	3.3K 1/6W CARBON RES	IS
	R913	QRD167J-392	3.9K 1/6W CARBON RES	IS
	R914	QRD161J-242	2.4K 1/6W CARBON RES	IS
	R915	QRD167J-153	15K 1/6W CARBON RES	IS
	R916	QRD167J-562	5.6K 1/6W CARBON RES	IS

Δ : SAFETY PARTS

Resistors

Δ	ITEM	PART NUMBER	DESCRIPTION		AREA
	R925	QRD161J-432	4.3K	1/6W CARBON RES	IS
	R926	QRD161J-432	4.3K	1/6W CARBON RES	IS
	R927	QRD167J-103	10K	1/6W CARBON	
	R928	QRD167J-103	10K	1/6W CARBON	
	R929	QRD167J-913	91K	1/6W CARBON RES	IS
	R930	QRD167J-913	91K	1/6W CARBON RES	IS
	R931	QRD167J-822	8.2K	1/6W CARBON RES	IS
	R932	QRD167J-822	8.2K	1/6W CARBON RES	IS
	R933	QRD161J-163	16K	1/6W CARBON RES	IS
	R934	QRD161J-163	16K	1/6W CARBON RES	IS
	R941	QRD167J-103	10K	1/6W CARBON	
	R942	QRD167J-103	10K	1/6W CARBON	
	R943	QRD161J-184	180K	1/6W CARBON RES	IS
	R944	QRD167J-224	220K	1/6W CARBON	
	R945	QRD167J-224	220K	1/6W CARBON	
	R946	QRD167J-224	220K	1/6W CARBON	
	R947	QRD161J-132	1.3K	1/6W CARBON RES	IS
	R948	QVPG401-103	10K	VARIABLE R	ES
	R949	QRD167J-243	24K	1/6W CARBON	
	R950	QRD167J-133	13K	1/6W CARBON	
	R951	QRD167J-683	68K	1/6W CARBON RES	IS
	RA901	QRB069J-103	10K	1/10W RESISTOR	SI
	RA902	QRB079J-222	2.2K	1/10W NETWORK RE	SI

Δ SAFETY PARTS

Others

Δ	ITEM	PART NUMBER	DESCRIPTION		AREA
	J201	VMC0163-R06	CONNECT TERMINAL 6PIN		
	J202	VMC0163-R06	CONNECT TERMINAL 6		
	J805	VMC0107-R04	SPEAKER JACK		
	J931	VMC0107-R05	CONNECT TERMINAL		
	P921	VMC0234-P11	CONNECT TERMINAL 11		
	P922	VMC0234-P14	CONNECT TERMINAL 14		
	P923	VMC0234-P08	CONNECT TERMINAL 8		
	P924	VMC0234-P08	CONNECT TERMINAL 8		
	P981	EMV5142-911	CONNECT TERMINAL 11		
	S801	ESP0001-023ZJ5	TACT SWITCH CLEAR		
	S802	ESP0001-023ZJ5	TACT SWITCH		
	S803	ESP0001-023ZJ5	TACT SWITCH		
	S804	ESP0001-023ZJ5	TACT SWITCH		
	S805	ESP0001-023ZJ5	TACT SWITCH REPEAT		
	S806	ESP0001-023ZJ5	TACT SWITCH RANDOM		
	S807	ESP0001-023ZJ5	TACT SWITCH		
	S808	ESP0001-023ZJ5	TACT SWITCH SIDE A/B		
	S809	ESP0001-023ZJ5	TACT SWITCH EDIT		
	S810	ESP0001-023ZJ5	TACT SWITCH CD REC		
	S811	ESP0001-023ZJ5	TACT SWITCH + CD REC		
	S812	ESP0001-023ZJ5	TACT SWITCH PROGRAM		
	S813	ESP0001-023ZJ5	TACT SWITCH FM		
	S814	ESP0001-023ZJ5	TACT SWITCH AM		
	S815	ESP0001-023ZJ5	TACT SWITCH PRESET V		
	S816	ESP0001-023ZJ5	TACT SWITCH PRESET A		
	S817	ESP0001-023ZJ5	TACT SWITCH TUN >		
	S818	ESP0001-023ZJ5	TACT SWITCH TUN <		
	S819	ESP0001-023ZJ5	TACT SWITCH DAILY		
	S820	ESP0001-023ZJ5	TACT SWITCH CLOCK ADJ		
	S821	ESP0001-023ZJ5	TACT SWITCH MEMORY		
	S831	ESP0001-023ZJ5	TACT SWITCH H.PHONE		
	S832	ESP0001-023ZJ5	TACT SWITCH CAR		
	S833	ESP0001-023ZJ5	TACT SWITCH BGM		
	S834	ESP0001-023ZJ5	TACT SWITCH STADIUM		
	S835	ESP0001-023ZJ5	TACT SWITCH HALL		
	S836	ESP0001-023ZJ5	TACT SWITCH D.CLUB		
	S837	ESP0001-023ZJ5	TACT SWITCH VOCAL MASK		U
	S837	ESP0001-023ZJ5	TACT SWITCH VOCAL MASK		UC
	S837	ESP0001-023ZJ5	TACT SWITCH VOCAL MASK		US
	S837	ESP0001-023ZJ5	TACT SWITCH VOCAL MASK		UT
	S838	ESP0001-023ZJ5	TACT SWITCH POWER		
	S839	ESP0001-023ZJ5	TACT SWITCH A.BASS.EX		
	S840	ESP0001-023ZJ5	TACT SWITCH HAUX		
	BC201	EWS243-065J	SOCKET WIRE ASSY4		
	BC202	EWS247-012J	SOCKET WIRE ASSY7		
	BC512	EWS293-0120	SOCKET WIRE3		
	FL801	ELU0001-173	FLUORESCENT DISPLAY TUBE		
	FW805	EWR340-13LS	FLAT WIRE ASSY4		
	FW851	EWR350-16LS	CORDS		
	FW911	EWR340-13LS	FLAT WIRE ASSY10		
	FW931	EWR350-16LS	CORDS		
	FW999	EWR330-10LS	FLAT WIRE ASSY3		U
	FW999	EWR330-10LS	FLAT WIRE ASSY3		UC
	FW999	EWR330-10LS	FLAT WIRE ASSY3		US
	FW999	EWR330-10LS	FLAT WIRE ASSY3		UT
	JA801	VMC0163-R13	CONNECT TERMINAL 13PIN		
	JA802	VMC0163-R17	CONNECT TERMINAL 17		
	JA803	EMV7124-006	SOCKET 6		
	JB801	VMC0163-R13	CONNECT TERMINAL 13		
	JB901	VMC0163-R21	CONNECT TERMINAL 21		
	TW907	EWT011-078	TERMINAL WIRE ASSY		U
	TW907	EWT011-078	TERMINAL WIRE ASSY		UC
	TW907	EWT011-078	TERMINAL WIRE ASSY		US
	TW907	EWT011-078	TERMINAL WIRE ASSY		UT
	XT901	ECX0004-194KM	CERAMIC RESONATOR		

Δ SAFETY PARTS

△	Item	Part Number	Part Name	Q'ty	Description	Area
		RM-SES20XU	WIRE-LESS REMOTE CONTROL	1		UT
		RM-SES20U	WIRE-LESS REMOTE CONTROL	1		VX
	10	PECA0786	RECAHRGEBLE BATTERY	2		A
	11	BT-20122	WARRANTY CARD	1		A
	12	BT-20122-1	STICKER	1		A
	13	BT20060	WARRANTY CARD	1		BS
	14	BT-20066A	WARRANTY CARD	1		BS
	15	BT-20025K	WARRANTY CARD	1		C
	16	BT-20071A	C = SVC CENTER	1		C
	17	BT-20134	WARRANTY CARD	1		G
	18	BT-20044G	SAFETY SHEET	1		J
	19	BT-51006-1	REGISTER CARD	1		J
	20	E35497-019	CAUTION SHEET	1		U
		E35497-019	CAUTION SHEET	1		UC
		E35497-019	CAUTION SHEET	1		US
		E35497-019	CAUTION SHEET	1		UT
		E306858-002	CAUTION SHEET	1		UT

△ : Safety

The Marks for Designated Areas

A	Australia	BS	the U.K.	C	Canada	EF	Continental Europe
EN	Scandinavia	G	Germany	GI	Italy	J	the U.S.A.
U	Universal Type	UC	China	US	Singapore	UT	Taiwan
VX	East Europe	No mark indicates all area.					

Packing Materials and Part Numbers

Symbol No.

M	5	M	M
---	---	---	---

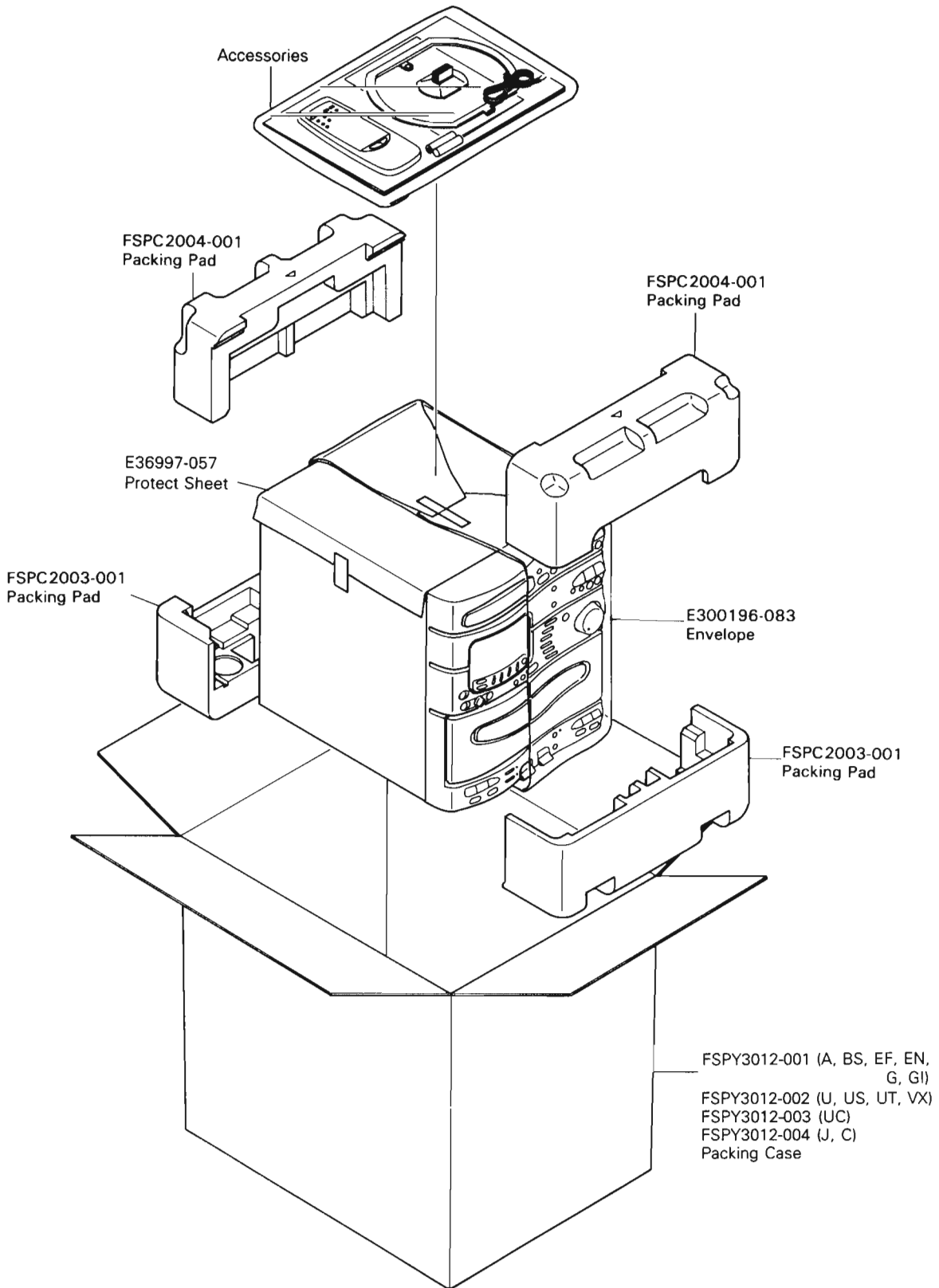

The Marks for Designated Areas

A	Australia	BS	the U.K.	EF	Scandinavia
EN	Continental Europe	G	Germany	GI	Italy
U	Universal Type	UC	China	US	Singapore
UT	Taiwan	VX	East Europe	J	the U.S.A
C	Canada	No mark indicates all area.					

