

JVC

SERVICE MANUAL

COMPACT COMPONENT SYSTEM

CA-TD5/CA-TD55R

Pick up	OPT-60
CD Lsi	MN35510

Area Suffix

A	Australia
BS	The U.K.
EF	Continental Europe Except Germany & Italy
EN	Nordic Countries
G	Germany
VX	Eastern Europe
UB	Hong Kong
UP	Korea
US	Singapore
UT	Taiwan
U	Universal except all of above

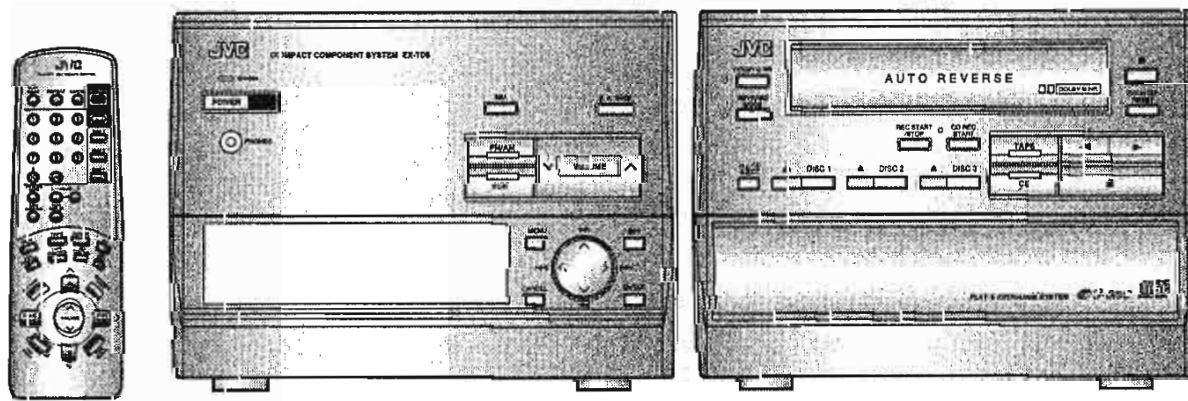

COMPACT
disc
DIGITAL AUDIO

Contents

Safety Precautions	1-2	XT-TD5/XT-TD55R.....	3-1
Important for Laser Products	1-3	Descriptions of Major ICs	3-1
Instruction Book	1-4	Main parts Layout	3-9
RX-TD5/RX-TD55R.....	2-1	Disassembly Procedures	3-10
Description of Major ICs	2-1	Block Diagrams	3-26
Internal Connection of Display	2-8	Schematic Diagram	3-27
Main parts Layout	2-9	Printed Circuit Boards	3-29
Disassembly Procedures	2-10	Parts List	
Adjustment Procedures	2-13	RX-TD5/RX-TD55R.....	4-1
Block Diagram	2-14	XT-TD5/XT-TD55R.....	5-1
Schematic Diagrams	2-15		
Printed Circuit Boards	2-23		

Safety Precautions

1. The design of this product contains special hardware and many circuits and components specially for safety purposes. For continued protection, no changes should be made to the original design unless authorized in writing by the manufacturer. Replacement parts must be identical to those used in the original circuits. Services should be performed by qualified personnel only.
2. Alterations of the design or circuitry of the product should not be made. Any design alterations of the product should not be made. Any design alterations or additions will void the manufacturer's warranty and will further relieve the manufacture of responsibility for personal injury or property damage resulting therefrom.
3. Many electrical and mechanical parts in the products have special safety-related characteristics. These characteristics are often not evident from visual inspection nor can the protection afforded by them necessarily be obtained by using replacement components rated for higher voltage, wattage, etc. Replacement parts which have these special safety characteristics are identified in the Parts List of Service Manual. Electrical components having such features are identified by shading on the schematics and by (Δ) on the Parts List in the Service Manual. The use of a substitute replacement which does not have the same safety characteristics as the recommended replacement parts shown in the Parts List of Service Manual may create shock, fire, or other hazards.
4. The leads in the products are routed and dressed with ties, clamps, tubings, barriers and the like to be separated from live parts, high temperature parts, moving parts and/or sharp edges for the prevention of electric shock and fire hazard. When service is required, the original lead routing and dress should be observed, and it should be confirmed that they have been returned to normal, after re-assembling.
5. Leakage current check (Electrical shock hazard testing)
After re-assembling the product, always perform an isolation check on the exposed metal parts of the product (antenna terminals, knobs, metal cabinet, screw heads, headphone jack, control shafts, etc.) to be sure the product is safe to operate without danger of electrical shock.

Do not use a line isolation transformer during this check.

- Plug the AC line cord directly into the AC outlet. Using a "Leakage Current Tester", measure the leakage current from each exposed metal parts of the cabinet, particularly any exposed metal part having a return path to the chassis, to a known good earth ground. Any leakage current must not exceed 0.5mA AC (r.m.s.).

- Alternate check method

Plug the AC line cord directly into the AC outlet. Use an AC voltmeter having, 1,000 ohms per volt or more sensitivity in the following manner. Connect a 1,500 Ω 10 W resistor paralleled by a 0.15 μ F AC-type capacitor between an exposed metal part and a known good earth ground.

Measure the AC voltage across the resistor with the AC voltmeter.

Move the resistor connection to each exposed metal part, particularly any exposed metal part having a return path to the chassis, and measure the AC voltage across the resistor.

Now, reverse the plug in the AC outlet and repeat each measurement. Any voltage measured must not exceed 0.75 V AC (r.m.s.). This corresponds to 0.5 mA AC (r.m.s.).

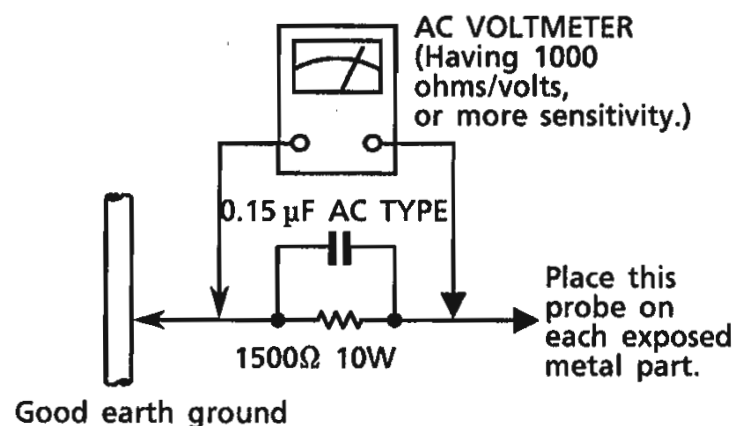

Warning

1. This equipment has been designed and manufactured to meet international safety standards.
2. It is the legal responsibility of the repairer to ensure that these safety standards are maintained.
3. Repairs must be made in accordance with the relevant safety standards.
4. It is essential that safety critical components are replaced by approved parts.
5. If mains voltage selector is provided, check setting for local voltage.

Important for Laser Products

1.CLASS 1 LASER PRODUCT

2.DANGER : Invisible laser radiation when open and inter lock failed or defeated. Avoid direct exposure to beam.

3.CAUTION : There are no serviceable parts inside the Laser Unit. Do not disassemble the Laser Unit. Replace the complete Laser Unit if it malfunctions.

4.CAUTION : The compact disc player uses invisible laserradiation and is equipped with safety switches which prevent emission of radiation when the drawer is open and the safety interlocks have failed or are defeated. It is dangerous to defeat the safety switches.

5.CAUTION : If safety switches malfunction, the laser is able to function.

6.CAUTION : Use of controls, adjustments or performance of procedures other than those specified herein may result in hazardous radiation exposure.

VARNING : Osynlig laserstrålning är denna del är öppnad och spårren är urkopplad. Betrakta ej strålen.
VARO : Avattaessa ja suojalukitus ohitettaessa olet alltiina näkymättömälle lasersäteilylle. Älä katso säteeseen.

ADVARSEL : Usynlig laserstrålning ved åbning , når sikkerhedsafbrydere er ude af funktion. Undgå udsættelse for stråling.
ADVARSEL : Usynlig laserstrålning ved åpning, når sikkerhetsbryteren er avslott. unngå utsettelse for stråling.

REPRODUCTION AND POSITION OF LABELS

WARNING LABEL

(Except for the U.S.A)

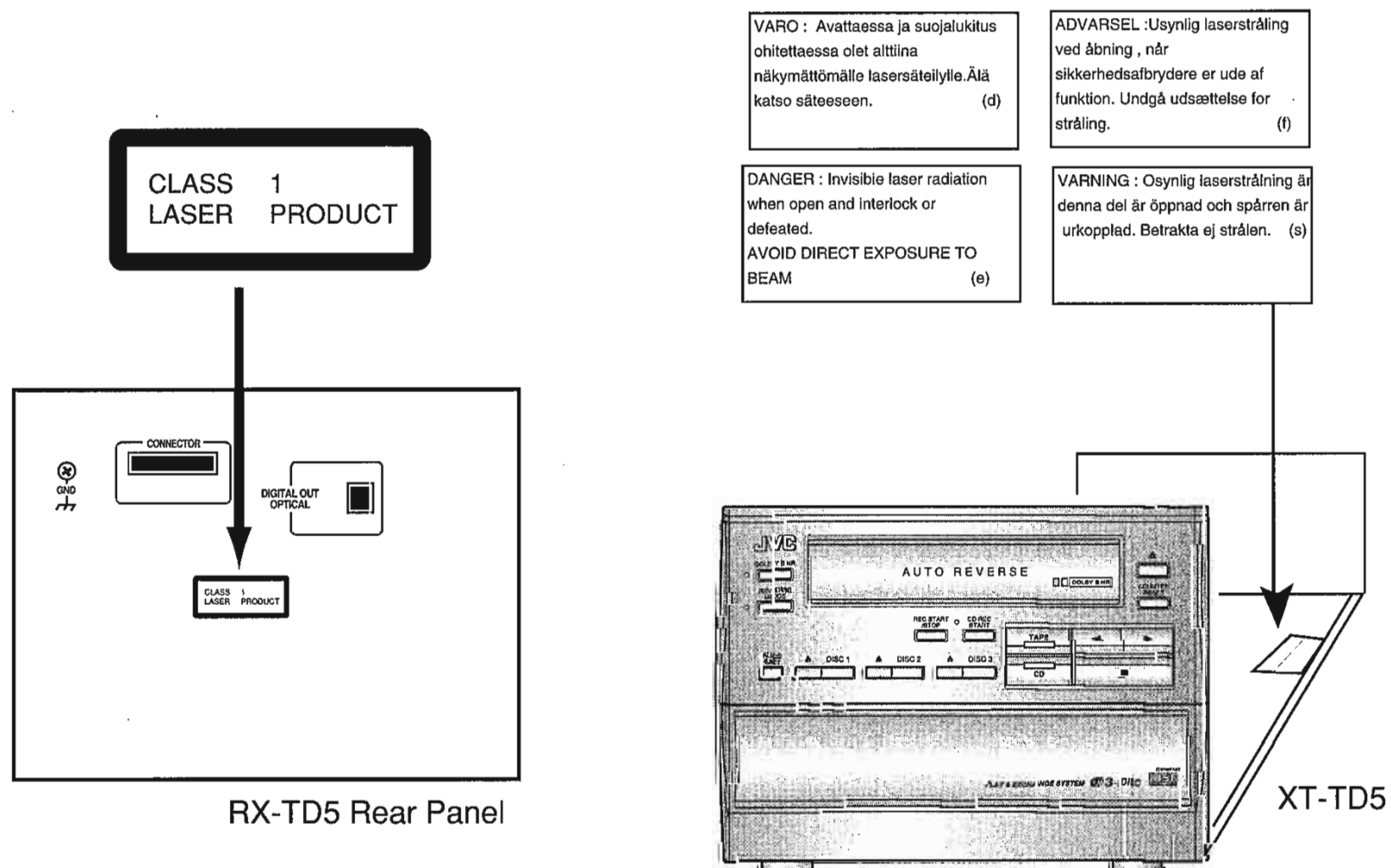

Table of Contents

Features.....	1
How This Manual Is Organized.....	1
IMPORTANT CAUTIONS.....	1
Getting Started	3
Accessories.....	3
How To Put Batteries In the Remote Control.....	3
Using the Remote Control.....	3
Connecting the System Control Cord.....	4
Connecting the External Wire.....	4
Connecting the FM Antenna.....	5
Connecting the AM (MW/LW) Antenna.....	5
Connecting the Speakers.....	6
Connecting a VCR.....	7
Connecting the MD Player.....	7
COMPU PLAY.....	7
Setting the Clock.....	8
Adjusting the Brightness of the Display.....	8
Common Operations	9
Turning the Power On and Off.....	9
Turning the System On.....	9
Turning the System Off.....	9
Adjusting the Volume.....	10
FADE MUTING Function.....	10
Balance adjustment.....	10
Reinforcing the Bass Sound.....	10
Sound Modes.....	11
Selecting a Surround Effect Mode.....	11
Selecting a S.E.A. Effect Mode.....	11
Customizing a S.E.A. Effect Mode.....	12
Using the Tuner	14
One Touch Radio.....	15
Tuning In a Station.....	15
Switching between Frequency Bands.....	15
Selecting a radio station.....	15
To Change the FM Reception Mode.....	15
Presetting Stations.....	16
Receiving FM Stations with RDS (CA-TD55R only).....	16
What Information RDS can Provide.....	16
Changing the Display.....	17
Searching for Programmes by PTY codes.....	17
EON Function.....	18
ALARM function.....	19
Using the CD Player	20
The Quickest Way To Start a CD Is With the One Touch Operation.....	21
Basics of Using the CD Player —	
Continuous Play.....	21
To Insert Discs.....	21
To Play a Disc.....	23
To Change Discs While Playing.....	23
To Select a Track.....	23
To Select a Passage Within a Track.....	24
Locating a Track With the Remote Control Directly.....	24
Programming the Playing Order of the Tracks.....	24
To Check the Program.....	26
To Modify the Program.....	26
Random Play.....	26
Repeating a Track or the Discs.....	27
Tray Lock Function.....	28
Locking the Electronic Lock.....	28
Unlocking the Electronic Lock.....	28
Using the Cassette Deck (Listening to a Tape)	29
One Touch Play.....	29
Regular Play.....	30
Tape Direction Indicator and the Display.....	30
Fast Forward and Rewind.....	31
Music Scan.....	31
Other Useful Features of the Cassette Deck.....	31
Reverse Mode.....	31
DOLBY B NR.....	31
To Control the Cassette Deck While Another Source is being Played.....	31
Using the Cassette Deck (Recording)	32
Things To Know Before You Start Recording.....	32
Standard Recording.....	33
To Record Any Sound Source To Tape.....	33
Checking the Tape Counter While Recording.....	33
How to create a blank section on the tape.....	33
CD Direct Recording.....	34
Auto Edit Recording.....	34
Using the Timer	36
Setting the DAILY Timer.....	36
Turning the DAILY Timer On and Off.....	38
Setting the ONCE REC (Recording) Timer.....	39
Turning the ONCE REC Timer On and Off.....	40
Setting the SLEEP Timer.....	41
Timer Priority.....	41
Using the VCR	42
Operating a JVC VCR.....	42
Listening to a JVC VCR.....	42
Recording of a JVC VCR.....	43
Operating a CR other than JVC's VCR.....	43
Listening to a VCR.....	43
Recording to a VCR.....	43
Care And Maintenance	44
Troubleshooting	45
Specifications	46

CA-TD5/CA-TD55R Instruction Book

Getting Started

Accessories

Check that you have all of the following items, which are supplied with the System.

- AM (MW/LW) Loop Antenna (1)
- Remote Control (1)
- Batteries (2)
- FM Wire Antenna (1)
- External Wire (1)

If any of these items is missing, contact your dealer immediately.

How To Put Batteries In the Remote Control

Match the polarity (+ and -) on the batteries with the + and - markings in the battery compartment.

R6P(SUM-3)/AA(15F)

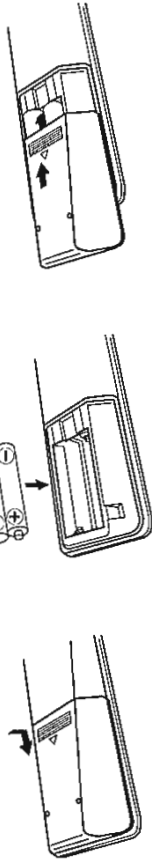

CAUTION: Handle batteries properly.

To avoid battery leakage or explosion:

- Remove batteries when the Remote Control will not be used for a long time.
- When you need to replace the batteries, replace both batteries at the same time with new ones.
- Don't use an old battery with a new one.
- Don't use different types of batteries together.

Using the Remote Control

The Remote Control makes it easy to use many of the functions of the System from a distance of up to 7m (23 feet) away.

You need to point the Remote Control at the remote sensor on the System's front panel.

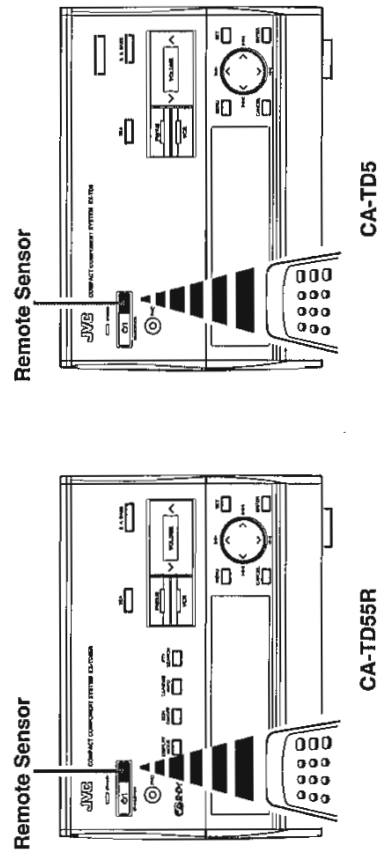

CAUTION: Make all connections before plugging the Unit into an AC power outlet.

Connecting the System Control Cord

Connect the components exactly as illustrated below.

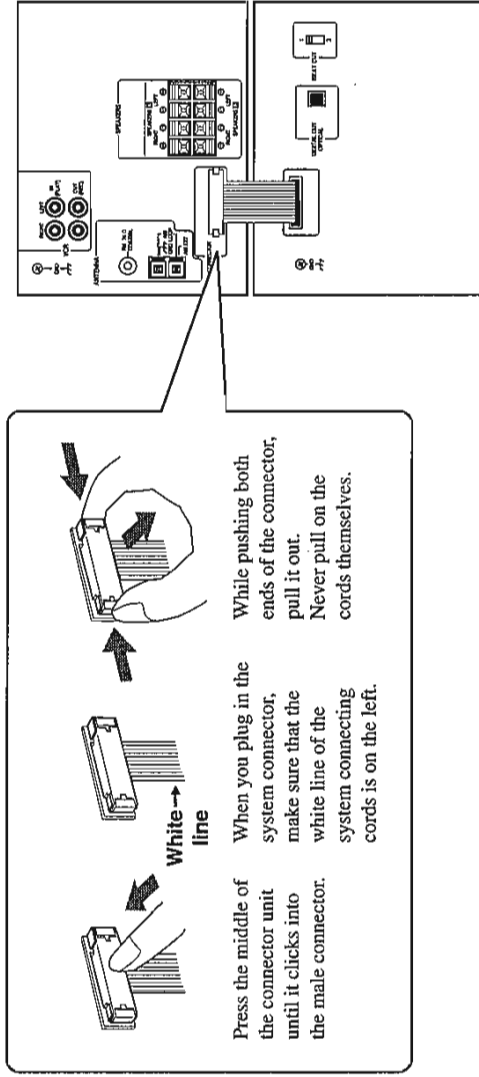

Connecting the External Wire

CAUTION: To prevent malfunction, connect the supplied wire as illustrated below.

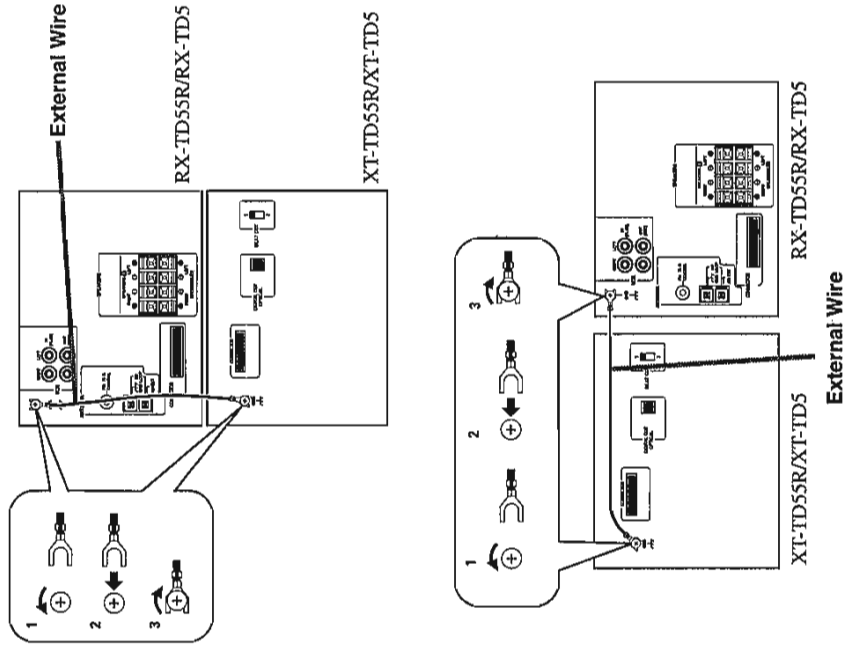

CAUTION: Make all connections before plugging the Unit into an AC power outlet.

Connecting the FM Antenna

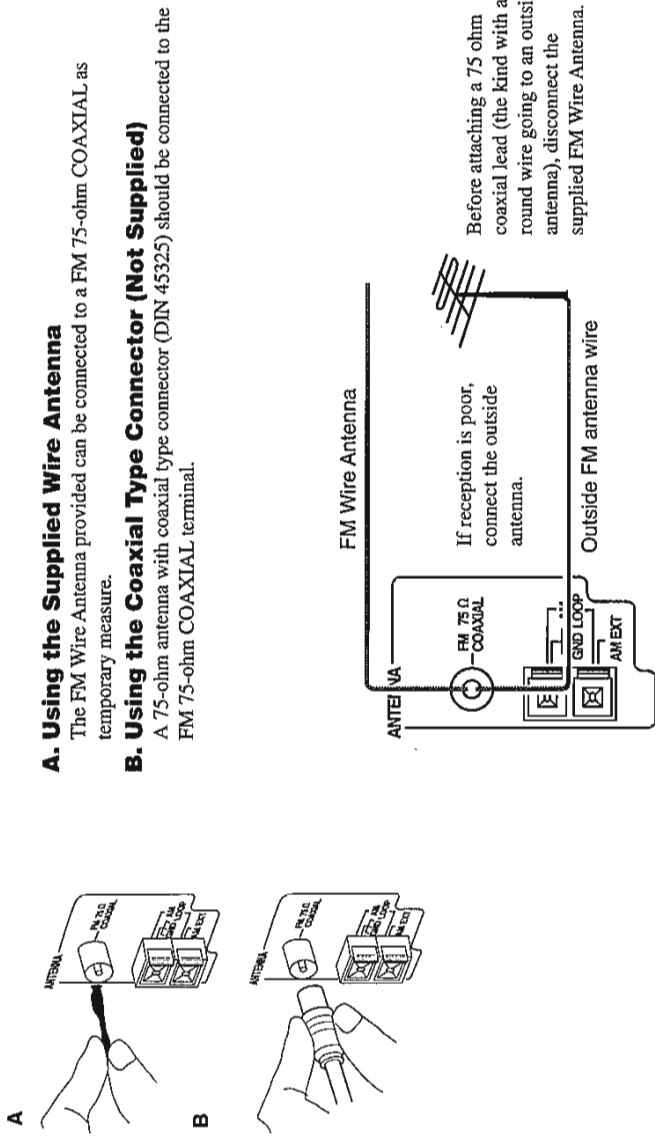

CAUTION: To avoid noise, keep antennas away from metallic parts of the System, connecting cord and the AC power cord.

Connecting the AM (MW/LW) Antenna

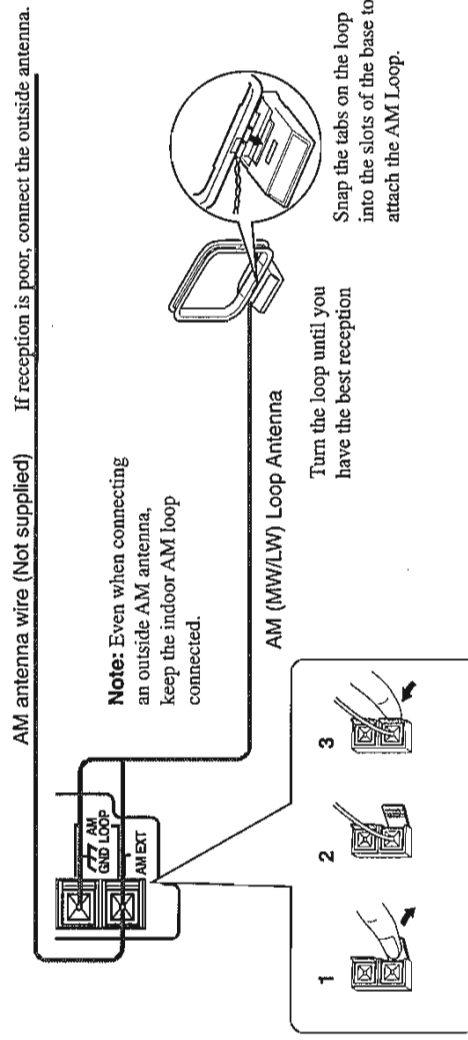

Connecting a VCR

Connect the VCR to the VCR terminal.

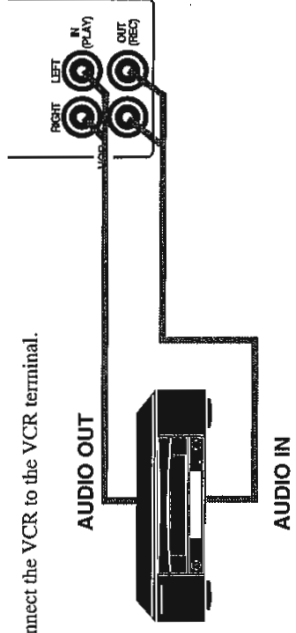

Connecting the MD Player

You can use a digital fiber-optic cable to connect the MD Player for recording CDs. Remove the cap from the DIGITAL OUT OPTICAL terminal and connect the digital fiber-optic cable. (Not supplied.)

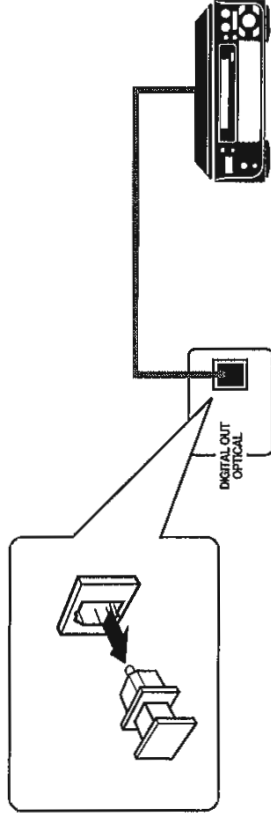

Now you can plug the AC power cord into the wall outlet, and your System is at your command!

COMPU PLAY

COMPU PLAY is JVC's feature that lets you control the most frequently used functions of the System with a single touch. One Touch Operation starts playing a CD, turns on the radio, plays a tape, etc. with a single press of the play button for that function. What One Touch Operation does for you is to turn the power on, then start the function you have specified. If the Unit is not ready, such as no CD or tape in place, the Unit still powers on so you can insert a CD or tape.

How One Touch Operation works in each case is explained in the section dealing with that function. The COMPU PLAY buttons are:

On the Unit

- FM/AM button
- VCR button
- TAPE button
- CD button
- CD Player DISC 1 to DISC 3 buttons
- CD Player Open/Close (▲) buttons
- CD Player ALL CD EJECT button
- Cassette Deck Open/Close (▲) button

On the Remote Control

- DISC 1 to DISC 3 buttons
- VCR button
- TAPE button
- TUNER button
- CD button

CAUTION: Make all connections before plugging the Unit into an AC power outlet.

Connecting the Speakers

Please refer to instructions for speakers as well when you connect speakers.

For each speaker connect one end of the speaker wire to the speaker terminals on the back of the System and one end to the speaker.

1. Open each terminal.
2. Insert the end of the speaker wire as shown (be sure to remove the insulation at the end of each wire first.)
3. Close the terminals to clamp the speaker wires firmly in place.

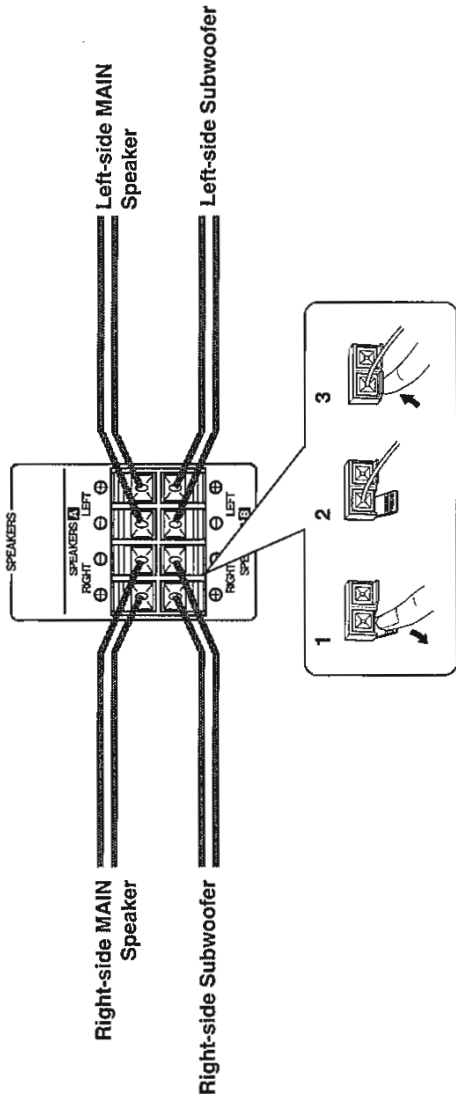

SPEAKERS A

Connect the MAIN Speakers to the SPEAKERS A terminal on the rear panel as follows.

Connect the gray (+) and the blue (-) terminals of the right-side MAIN Speaker to the gray (+) and blue (-) terminals marked RIGHT on the rear panel.

Connect the gray (+) and the blue (-) terminals of the left-side MAIN Speaker to the gray (+) and blue (-) terminals marked LEFT on the rear panel.

SPEAKERS B

Connect the Subwoofers to the SPEAKERS B terminal on the rear panel as follows.

Connect the red (+) and black (-) terminals of the right-side Subwoofer to the red (+) and black (-) terminals marked RIGHT on the rear panel.

Connect the red (+) and black (-) terminals of the left-side Subwoofer to the red (+) and black (-) terminals marked LEFT on the rear panel.

IMPORTANT: Use speakers with the correct impedance only. The correct impedance is indicated on the back panel.

CAUTION: If a TV is installed near speakers, the TV may display irregular colours. In this case, set the speakers away from the TV.

Setting the Clock

The clock should be set before you start using this Unit. If the clock has not been set, "0:00" appears in the display and the CLOCK indicator blinks. You can set the clock regardless of whether the Unit is on or off.



1. Press the MENU button.
"DAILY" blinks on the display and the TIMER selection indicator lights up.

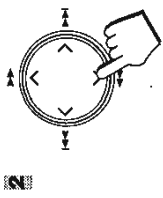

2. Press the < and > cursor key twice to select "CLOCK".
"CLOCK ADJ" blinks on the display.



3. Press the SET button.
The hour digits on the display blink.

4. Set the hour by pressing the < or > cursor key.
Pressing the > cursor key increases the hour, and pressing the < cursor key decreases it. Pressing down either of these cursor keys adjusts the setting continuously until the key is released.

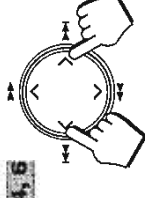

5. Press the SET button.
The minute digits on the display blink.

6. Set the minute by pressing the < or > cursor key.
Pressing the > cursor key increases the minute, and pressing the < cursor key decreases it. Holding down either of these cursor keys allows you to continuously adjust the minute setting in 10 minute increments until the key is released.



7. Press the ENTER button.
"CLOCK OK" appears on the display and the blinking "CLOCK" indicator disappears. The clock time starts from zero seconds from the set time.

To correct a mistake:

- Repeat the procedure from step 1 after pressing the ENTER key.
- To correct a setting during the procedure, press the CANCEL key to go back to the previous setting item.

Note: If you try to select DAILY or REC without first setting the clock, "CLOCK" and "ADJUST" are displayed alternately on the display, and you will be unable to set the timers.

CAUTION: If there is a power failure, the clock loses its setting. The display shows "0:00", and the clock must be reset.

Adjusting the Brightness of the Display

In Standby mode you can adjust the brightness of the clock display. Press the > cursor key to make the display brighter. Press the < cursor key to make the display darker.

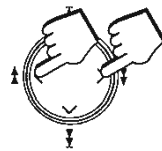

Common Operations

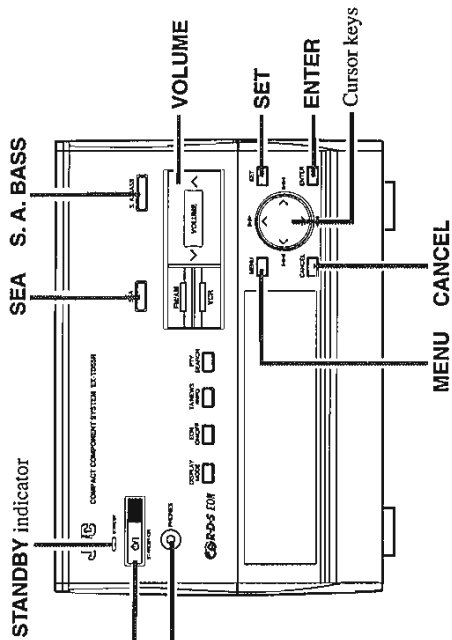

This illustration is of CA-TD55R, CA-TD5 does not have the DISPLAY MODE, EON ON/OFF, TA/NEWS/INFO, and PTY SEARCH buttons.

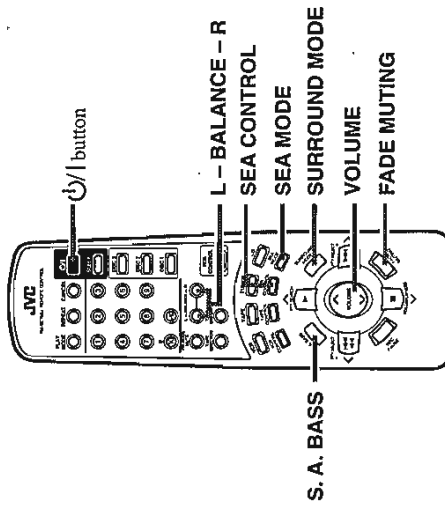

Display

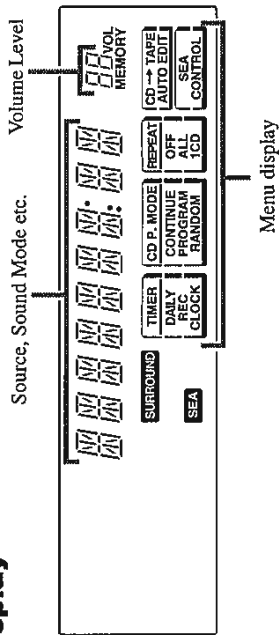

When the System is being used, the display shows other items as well. However, we have only shown the items described in this section. This illustration shows all the items in the Menu display. However, the menu items that are available will change, depending on the source selected.

This illustration shows the Remote Control for CA-TD55R. The Remote Control for CA-TD5 does not have the RDS CONTROL button or include any RDS related labels.

Turning the Power On and Off

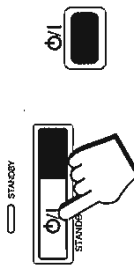

Turning the System On

Press the < button.

The display comes on and the STANDBY indicator goes out. The System comes on ready to tune in the mode it was in when the power was last turned off.

Turning the System Off

Press the < button again.

- The STANDBY indicator lights up and the display is blank, except for the clock display.
- Some power (12 watts) is always consumed even though power is turned off (called Standby Mode).
- To switch off the Unit completely, unplug the AC power cord from the AC outlet. When you unplug the AC power cord, the clock will be reset to 0:00 immediately, and preset Tuner stations will be erased after a few days.

Adjusting the Volume

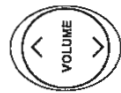
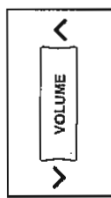

Using the Unit

To increase the volume, press the right side of the VOLUME button \blacktriangle . To decrease the volume, press the left side of the VOLUME button \blacktriangledown .

Using the Remote Control

- To increase the volume, press the up side of the VOLUME button \blacktriangle . To decrease the volume, press the down side of the VOLUME button \blacktriangledown .
- Press the button in steps to adjust the volume level one step at a time, press the button continuously to adjust the level continuously.
- You can adjust the volume level between 0 and 50.
- When the System is turned on from Standby mode, the volume is set to 0 and automatically increases to the previous volume level. To stop this automatic volume adjustment, press the VOLUME button.

For private listening

Connect a pair of headphones to the PHONES jack. No sound comes out of the speakers. Be sure to turn down the volume before connecting or putting on headphones.

FADE MUTING Function

Set the Volume Level to 0 by pressing the FADE MUTING button on the Remote Control. Press this button again to restore the Volume Level to its previous level.



Balance adjustment

You can use the Remote Control to adjust the left and right balance of the speakers.

Press the L - BALANCE - R buttons.

The display changes to show the balance adjustment.

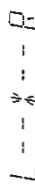

Pressing the L button moves the pointer to the left, pressing the R button moves the pointer to the right. Holding a button down, moves the pointer continuously.

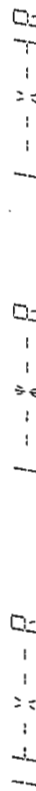

Display when set for no sound from the right speaker. Display at the centre position. Display when set for no sound from the left speaker.

The balance is normally set to the center position.

Note: If no adjustments are made for 4 seconds in balance adjustment mode, the display reverts to the previous display.

Reinforcing the Bass Sound

S.A. (Signal Adaptive) BASS adjusts low tones at low volume to enhance their effect. When the volume level is low, this enhances low tones that are normally difficult to hear and adjusts low tones to a fixed level to reduce low tone distortion.

Press the S.A. BASS button.

The S.A. BASS button lights up.



The display changes with each press of the S.A. (Signal Adaptive) BASS button as shown below.

→ SA-BASS 1 → SA-BASS 2 → OFF → (back to the beginning)

SA-BASS 2 enhances low tones more than SA-BASS 1.

To get the effect, press the S.A. BASS button and select SA-BASS 1 or SA-BASS 2. "SA-BASS 1" or "SA-BASS 2" appears in the display and the button indicator lights up.



When listening to recording with low volume low tones, the difference between SA-BASS 1 and SA-BASS 2 is clear. When listening to recording with louder low tones, however, the difference between SA-BASS 1 and SA-BASS 2 may not be so clear.

To cancel an effect, press the S.A. BASS button until "OFF" appears on the display. The S.A. BASS button indicator goes out. OFF

Sound Modes

The System has some preset sound effects that give you control of the way your music sounds, so you can tailor it for your room and for the quality of the source. We can give you some idea of how each one affects the music, but the only way to really tell is to try them yourself.

You can also create up to three of your own customized S.E.A. (Sound Effect Amplifier) settings and store them in the unit's memory.

- The preset sound modes include modes using surround effects and modes using S.E.A. effects.
- You cannot use Surround Effect mode and S.E.A. mode at the same time.
- Sound Mode effects cannot be recorded.

Surround effect modes

- D. CLUB (Dance Club)** Increases resonance and bass.
- HALL** Adds depth and brilliance to the sound, like in a concert hall.
- STADIUM** Adds clarity and spreads the sound, like in an outdoor stadium.

S.E.A. effect modes

- ROCK** Boosts low and high frequencies.
- POP** Good for vocal music.
- CLASSIC** Set for wide and dynamic sound stereo systems.

Selecting a Surround Effect Mode Press the SURROUND MODE button on the Remote Control.

The "SURROUND" indicator on the display lights up.

The display changes with each press of the button as shown below.



→ D. CLUB → HALL → STADIUM → OFF → (back to the beginning)

If a S.E.A. effect is already selected, the unit automatically switches to Surround effect mode.

The name of the effect appears on the display, then returns to the previous display after a few seconds.

If you want to see the name of the selected mode, press the SURROUND MODE button once. The name of the currently selected mode appears on the display for a few seconds.

To cancel Surround effect mode, select "OFF". The "SURROUND" indicator goes out.

Selecting a S.E.A. Effect Mode Press the SEA button (or the SEA MODE button on the Remote Control).

The "SEA" indicator on the display lights up.

The display changes with each press of the button as shown below.



→ ROCK → POP → CLASSIC → MANUAL 1 → MANUAL 2 → MANUAL 3 → OFF → (back to the beginning)

If a Surround effect is already selected, the unit automatically switches to S.E.A. effect mode.

The name of the effect appears on the display, then returns to the previous display after a few seconds.

If you want to see the name of the selected mode, press the SEA MODE button once. The name of the currently selected mode appears on the display for a few seconds.

To cancel S.E.A. effect mode, select "OFF". The "SEA" indicator goes out.

Customizing a S.E.A. Effect Mode

You can create up to three of your own customized S.E.A. settings and store them in the unit's memory.

- You can adjust the level of the LOW, MID, or HIGH tones.
- You can change an existing sound mode to suit your own preferences by adding your own S.E.A. effects to the existing effect. To create an S.E.A. effect from a flat level, perform the following steps after selecting "OFF" for S.E.A. effect mode.



1.

Press the MENU button.

The "TIMER" section of the menu display blinks.

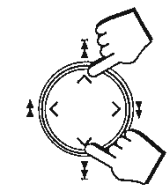

2.

Press the cursor key to the right or left (← or →) and select "SEA CONTROL".

The display changes with each press of the cursor keys as shown below.

When a CD source is selected:

- Press the left (←) cursor key
← TIMER ↔ CD P.MODE ↔ REPEAT ↔ AUTO EDIT ↔ SEA CONTROL ↔
- Press the right (→) cursor key →

When any other source is selected:

TIMER ↔ SEA CONTROL



3.

Press the SET button.

"LOW 0dB" blinks on the display.

- If S.E.A. is already on, the low tones for the selected S.E.A. MODE are displayed.



The level for the low tones of the S.E.A. effect appears on the display while the "SEA CONTROL" indicator is lit.

Adjust the level of the low (LOW), middle (MID), or high (HIGH) tones.

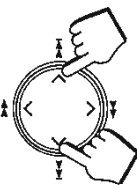

Using the Unit

- Select the "LOW", "MID", or "HIGH" tone ranges by adjusting the cursor keys left and right (← or →).

The display changes with each press of the cursor keys as shown below.

- Press the left (←) cursor key
← LOW ↔ MID ↔ HIGH ↔
- Press the right (→) cursor key →

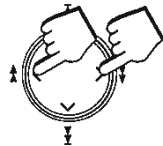

- Adjust the level of the selected tone range by adjusting the cursor keys up and down (↑ or ↓ or ↕).

Pressing the ↑ cursor key increases the level in 2dB units, and pressing the ↓ cursor key decreases it in 2dB units.

- You can adjust the level between -6dB and +6dB in seven steps.



Using the Remote Control

- Press the SEA CONTROL button.
- Select the "LOW", "MID", or "HIGH" tone ranges by pressing the ← or → cursor keys.

The display changes with each press of the buttons as shown below.

- Press the ← or → button
← LOW ↔ MID ↔ HIGH ↔
- Press the ↑ or ↓ button →

- Adjust the level of the selected tone range by pressing the ↕ or ↕ button.

You can adjust the level between -6dB and +6 dB in seven steps.

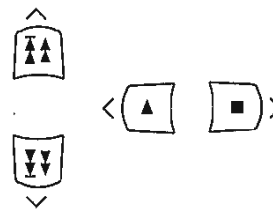

5. Press the SET button.

"MANUAL 1" blinks on the display.

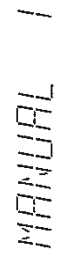

6. Select the number for the MANUAL setting.

Using the Unit

Press the cursor key to the right or left (← or →) and select the number.

Using the Remote Control

Select the number by pressing the ← or → button.

The display changes with each press of the buttons or cursor keys as shown below.

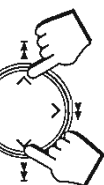

On the unit:

- Press the left (←) button
← MANUAL 1 ↔ MANUAL 2 ↔ MANUAL 3 ↔
- Press the right (→) button →

On the Remote Control:

- Press the ← button
← MANUAL 1 ↔ MANUAL 2 ↔ MANUAL 3 ↔
- Press the → button →



7.

Press the ENTER button.

"MEMORY" and the selected memory number are displayed on the screen, and the adjusted settings are stored in memory. After a few seconds, the display reverts to the item that was displayed before you pressed the MENU button.

- The memory setting will appear in the S.E.A. effect mode using the manual number.



If you store new settings to a MANUAL number that has already been used, the new settings replace the existing setting.

Using the Tuner

CA-TD55R

FM/AM button

Press this to select the Tuner as the source. The button indicator lights up and the cursor keys operate in Tuner control mode.

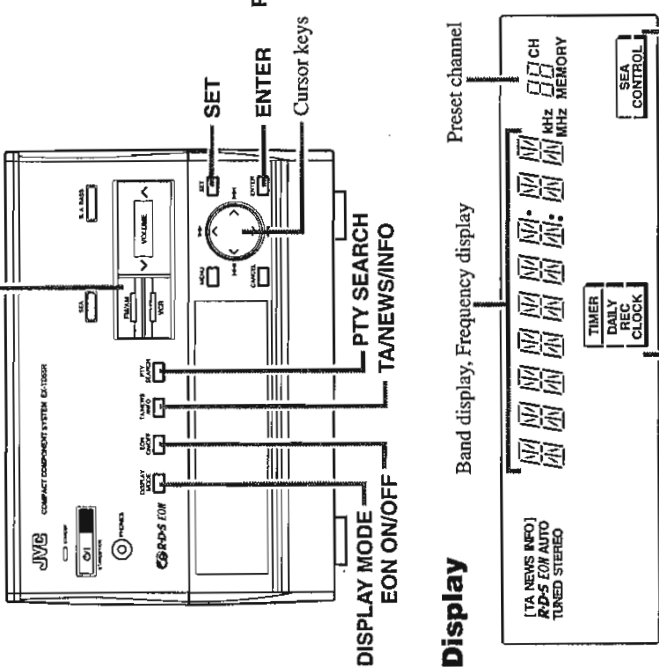

Display

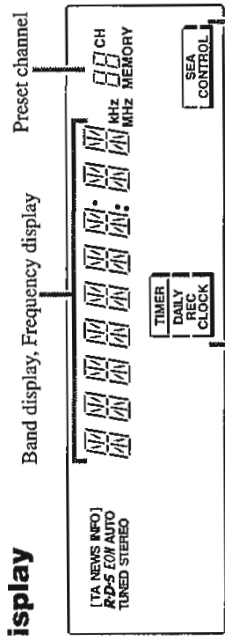

TUNER button

Press this button to select the Tuner as the source and switch the Remote Control Tuner control mode.

When the System is being used, the display shows other items as well. However, we have only shown the items described in this section. This illustration shows only the Menu display items for the Tuner.

Number keys

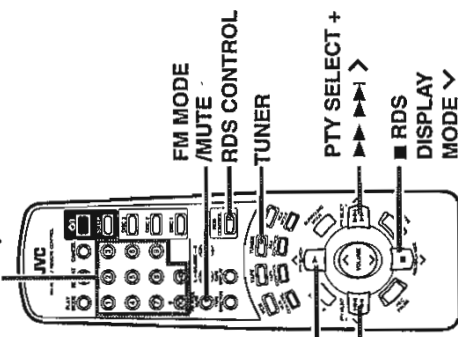

CA-TD5

FM/AM button

Press this to select the Tuner as the source. The button indicator lights up and the cursor keys operate in Tuner control mode.

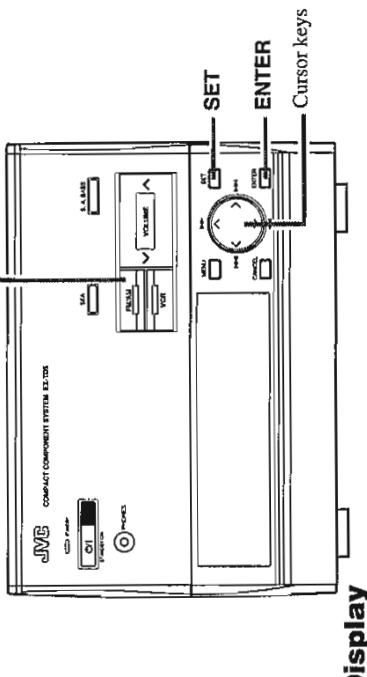

Display

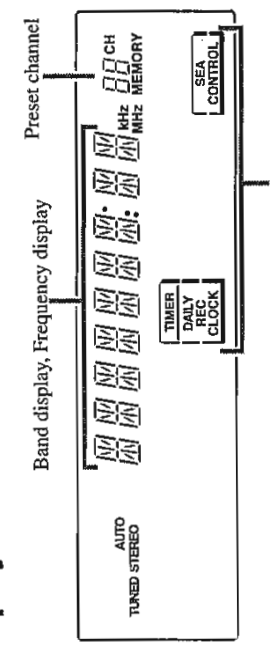

TUNER button

Press this button to select the Tuner as the source and switch the Remote Control Tuner control mode.

When the System is being used, the display shows other items as well. However, we have only shown the items described in this section. This illustration shows only the Menu display items for the Tuner.

You can listen to both FM and AM (MW/LW) stations. Stations can be tuned in manually, automatically, or from preset memory storage.

- Before listening to the radio:
- Check that both the FM and AM (MW/LW) antennas are firmly connected. (See page 5).

One Touch Radio

Just press the FM/AM button (or the TUNER button on the Remote Control) to turn on the Unit and start playing the most recent station tuned in.

You can switch from any other sound source to the radio by pressing the FM/AM button (or the TUNER button on the Remote Control).

Tuning In a Station

Press the FM/AM button (or the TUNER button on the Remote Control) to turn on the radio. The Frequency of the previously selected channel appears on the display.

Switching between Frequency Bands Press the FM/AM button (or the TUNER button on the Remote Control).

Each time you press the button, the band alternates between FM and AM (MW/LW).

Selecting a radio station

Manual Tuning

Press the up and down cursor keys (▶▶ ▲ or ▼ ◀◀) to select the frequency. The frequency changes in one step increments. "TUNED" appears on the display when a signal is found.

Press the up cursor key (▶▶ ▲) to increase the frequency and the down cursor (▼ ◀◀) to decrease it.

Auto Tuning

Keep the up or down cursor key (▶▶ ▲ or ▼ ◀◀) pressed down to change the frequency continuously until a signal is found. "TUNED" will appear on the display when a signal is found. This is called Auto Tuning.

Preset Tuning (possible only after presetting stations)

Using the Unit

Select the a preset channel number by pressing the left and right (◀◀ ◁ or ▷ ▶▶) cursor keys.

Press the right cursor key (▷ ▶▶) to increase the preset channel number and the left cursor key (◀◀ ◁) to decrease it.

Using the Remote Control

Press the ▲ ▶ or ◀ ▼ after pressing the TUNER button to select a preset channel. Press the ▲ ▶ button to increase the preset channel number and the ◀ ▼ button to decrease it.

You can use the Remote Control to select a preset channel directly.

- Press the TUNER button so that you can receive the most recent station tuned in.
- Select the station by entering the preset channel in the number keys of the Remote Control.
 - Example: for channel 5, press 5. For channel 15, press +10 then 5. For channel 20, press +10, then 10. For channel 32, press +10 three times, then 2.

To Change the FM Reception Mode

When an FM stereo broadcast is hard to receive or noisy, press the FM MODE/MUTE button on the Remote Control so that the "AUTO" indicator goes off in the display. Reception improves, but there are no stereo effects. In this monaural mode, noise comes out while tuning in stations (since muting is also cancelled).



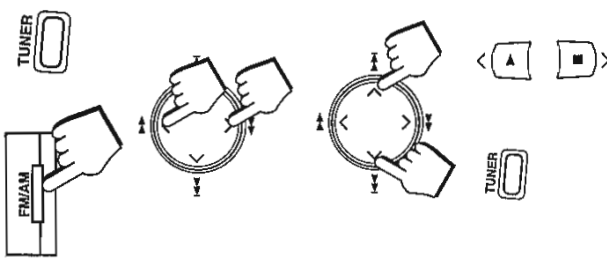

To restore the stereo effect, press the FM MODE/MUTE button on the Remote Control so that the "AUTO" indicator lights up. In this stereo mode, no noise comes out while tuning in stations, and you can hear stereo sounds when a program is broadcast in stereo.

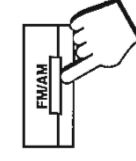
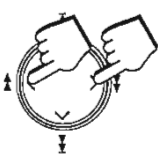

Presetting Stations

You can store up to 40 of your favorite radio stations (FM and AM (MW/LW)) in memory, giving you quick, easy access to the stations.

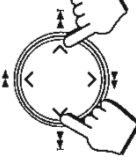
Note: In some cases, test frequencies have been already memorized for the tuner since the factory examined the tuner preset function before shipment. This is not a malfunction. You can preset the stations you want into memory by following the presetting method.

-  **1 Select a frequency band by pressing the FM/AM button.**
-  **2 Press the up or down cursor key (\blacktriangleright \blacktriangleleft or \blacktriangleright or \blacktriangleleft) to tune to a station.**
-  **3 Press the ENTER button .**
On the display, "MEMORY" will blink for 5 seconds.
 - During these 5 seconds while "MEMORY" is blinking, you can assign a channel number to the station and enter it into the memory.
-  **4 Press the right or left cursor key (\blacktriangleleft or \blacktriangleright) to select a preset channel number.**
-  **5 Press the ENTER button again.**
"MEMORY" appears on the display and that station is stored in the selected preset number.
 - If a station has been previously stored using the same channel number, this will be erased and the newly selected station will be stored.
 - If "MEMORY" in the display goes off, start again from step 3.
- 6 Repeat steps 1 to 5 for each station you want to store in memory with a preset number.**

CAUTION: If the Unit is unplugged or if a power failure occurs, the preset stations will be erased after a few days. If this happens, preset the station again.

Receiving FM Stations with RDS (CA-TD55R only)

RDS (Radio Data System) is a broadcasting service which a growing number of FM stations are now providing. It allows the FM stations to send additional signals along with their regular programme signals. For example, the stations send their station names and information about what type of programme they broadcast, such as sports or music, etc.

When tuned to an FM station which provides the RDS service, the RDS indicator lights up, the station frequency (and then the station name if sent) is displayed.

One convenient RDS service is "Enhanced Other Networks (EON)". This allows the Unit to automatically switch to a programme type of your choice when one starts in your broadcast area.

- Not all FM stations provide RDS service, nor do all RDS stations provide the same services. If in doubt, check with local radio stations for details on RDS services in your area.

Note: RDS may not work correctly if the station to which you are tuned is not transmitting properly or if the signal strength is weak.

What Information RDS can Provide

The System can use the following RDS service.

PS (Program Service name)

Identifies each station by a name.

TA (Traffic Announcement Identification)

Identifies that a traffic announcement is being broadcast in your area.

RT (Radio Text)

Allows the RDS station to send text messages that appear on the display of the unit.

PTY (Programme Type)

Identifies the type of RDS programme. This allows you to locate a specific type of programme being broadcast.

The programme types are as follows:

TRAFFIC:	Traffic announcement
NEWS:	News
INFO:	Programmes on medical service, weather forecast, etc.
POP M:	Pop music
ROCK M:	Rock music
M.O.R. M:	Middle-of-the-road music (usually called "easy listening")
LIGHT M:	Light music
CLASSICS:	Classics
OTHER M:	Other music
AFFAIRS:	Topical programme expanding on current news or affairs
SPORT:	Sports events
EDUCATE:	Educational programmes
DRAMA:	Radio plays
CULTURE:	Programmes on national or regional culture
SCIENCE:	Programmes on natural sciences and technology
VARIED:	Other programmes like comedies or ceremonies
NONE:	Undefined

ALARM: Emergency broadcasts

EON (Enhanced Other Networks Information)

Provides information available on RDS stations other than the one which is being received.

Changing the Display

You can see RDS information on the display.

To view RDS information on the display, press the DISPLAY MODE button. (When using the Remote Control, press the RDS DISPLAY MODE button after pressing the RDS CONTROL button.) Each time you press the button, the display changes to show the following information:

PS (Programme Service):

Station names will be displayed.

PTY (Programme Type):

Types of broadcast programmes will be displayed.

RT (Radio Text):

Text message sent by stations will be displayed.

Station Frequency:

Station frequencies.

- While RDS information is being received from a station, "WAIT PS", "WAIT PTY", or "WAIT RT" may appear on the display.

Searching for Programmes by PTY codes

One of the advantages of the RDS service is that you can locate a particular kind of programme by specifying the PTY codes.

- The PTY Search function is applicable to preset stations only.

To search for a programme using the PTY codes, follow this procedure: Using the Unit



Press the PTY SEARCH button.

"PTY" and "SELECT" appear alternately on the display.

Note: If no adjustments are made for 5 seconds in PTY Search mode, the display reverts to the previous display. Perform the next step while "PTY" and "SELECT" are being displayed.

2 Press the cursor key to the left or right (← or →) to select a PTY.

The display changes with each press of the cursor keys as shown below:

- ← Press the left (←) cursor key
- ↔ TRAFFIC ↔ NEWS ↔ INFO ↔ POP M ↔ ROCK M ↔ M.O.R. M ↔ LIGHT M ↔ CLASSICS ↔ OTHER M ↔ AFFAIRS ↔ SPORT ↔ EDUCATE ↔ DRAMA ↔ CULTURE ↔ SCIENCE ↔ VARIED ↔
- Press the right (→) cursor key →

3 Press the PTY SEARCH button again.

While the search function is running, the selected programme type and "SEARCH" alternate on the display. The preset number also change.

Using the Remote Control

1 Press the RDS CONTROL button.

2 Press the PTY SEARCH button.

"PTY" and "SELECT" appear alternately on the display.

Note: If no adjustments are made for 5 seconds in PTY Search mode, the display reverts to the previous display. Perform the next step while "PTY" and "SELECT" are being displayed.

3 Press the PTY SELECT - < or > button to choose a PTY.

The programme type display changes with each press of the PTY SELECT button as shown below.

- ← Press the PTY SELECT - < button
- ↔ TRAFFIC ↔ NEWS ↔ INFO ↔ POP M ↔ ROCK M ↔ M.O.R. M ↔ LIGHT M ↔ CLASSICS ↔ OTHER M ↔ AFFAIRS ↔ SPORT ↔ EDUCATE ↔ DRAMA ↔ CULTURE ↔ SCIENCE ↔ VARIED ↔
- Press the > button → PTY SELECT + button →

4 Press the PTY SEARCH button again.

While the search function is running, the selected programme type and "SEARCH" alternate on the display. The preset number also change.

Once the station which is broadcasting the selected PTY (Programme Type) is located, searching will stop. Then the station name (if PS code is being sent) will be indicated and the broadcast will commence. The Display will stay blinking for 10 seconds from the end of the searching function. If you press the PTY SEARCH button again during this period, search for the same PTY (Programme Type) will restart. The PTY Search function is completed when the indicated preset Number changes from blinking to continuously lit.

If a station broadcasting a selected PTY (Programme Type) cannot be found, "NOT" and "FOUND" are displayed alternately on the display after the Unit has searched through the preset numbers. The Unit will then return to the station to which it was tuned prior to the start of the PTY Search.

To cancel a PTY Search operation, press the PTY SEARCH button. "PTY" and "SELECT" are displayed alternately on the display for a few seconds, then the display return to the screen that was selected before PTY SEARCH was displayed.

Note: PTY Search can be used even while AM (MW/LW) broadcasts are being received.

EON Function

With the EON (Enhanced Other Networks) code, the Unit can perform a standby reception which will enable you to obtain desired information which is available from other stations.

- "EON" will be displayed while receiving stations with an EON code.
- EON Standby reception is applicable for preset stations only.
- You can set EON Standby reception regardless of types of receiving bands.

Setting EON Standby reception

1 Press the EON ON/OFF button.

[TA NEWS INFO], or the last EON information type selected, is displayed.





2 Select information you want by pressing the TA/NEWS/INFO button.

- TA:** Identifies that a traffic announcement is being broadcast in your area.
- NEWS:** News
- INFO:** Programmes on medical service, weather forecast, etc.
- With each pressing of the TA/NEWS/INFO button, indications will change as follows:
 - [TA] → [NEWS] → [INFO] →
 - [TA NEWS] → [NEWS INFO] → [TA NEWS INFO] → (back to the beginning)

As soon as your selection is entered the Unit will go into EON Standby reception mode.

If you want to cancel the EON function, turn off the [TA NEWS INFO] indicator by pressing the EON ON/OFF button.

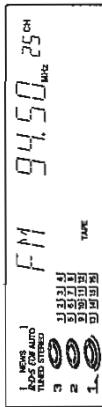
When this Unit carries out EON Standby reception, the indication will change as follows:

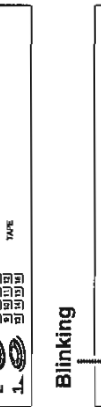
1. Waiting for EON Standby reception
 
2. Preset stations are being searched for and while preparing to change the station, sound will be muted.
 
3. The station will be changed and the programme type being received will appear on the display.
 

When using the DISPLAY MODE button to change the display, use the appropriate setting for the type of display.

Notes:

- EON broadcasts of some stations may not be compatible with this Unit. In the case of an incompatible EON broadcast, "EON" will not appear on the display.
- While the Unit is receiving information for an EON code you have selected for EON Standby, you cannot use the following operations: cursor key, TA/NEWS/INFO button or PTY SEARCH button. In addition, if a station transmits information for a programme type you have selected without sending the EON code, the EON Standby operation is still performed. Therefore, you will not be able to use the operations listed above during this period.
- If the reception is unsatisfactory for a station among the preset stations, "WAITING" appears on the display and the station is searched for again. If after searching through the channels five times, the broadcasting station cannot be found, "NOT" and "FOUND" are displayed alternately on the display. The Unit will then return to the station to which it was previously tuned.

When broadcasting of the desired information has been completed, "EON END" will be indicated and the Unit will automatically go back to the station which had previously been tuned to.

- While receiving information on EON Standby reception, the station will not change to other stations even if the same information is available from them.
- If you cancel the EON function when in EON Standby reception mode by either pressing the EON ON/OFF button, the Unit will automatically return to the station which had been previously tuned-in.

If the information you are waiting for is available from the current station, the indicator will blink.

ALARM function

If an ALARM (Emergency) signal is received while receiving an EON code from a station, "ALARM" blinks on the display and the Unit automatically switches to the station broadcasting the ALARM signal. When an ALARM broadcast of PTY is being received from the currently tuned-in station, "ALARM" will blink on the display for your attention.

Using the CD Player

The System's CD Player has an Automatic Changer with 3 disc trays. You can use Continuous, Random, Program or Repeat Play for the discs in DISC 1, DISC 2 and DISC 3. Repeat Play can repeat all the tracks on all the CD's, the tracks on one of the CD's or one track on one CD. There is also the Tray Lock function, which safely keeps discs in the trays.

Here are the basic things you need to know to play a CD and locate the different selections on it. Each selection is called a track, so when we are talking about locating a track, we are also talking about how you find a certain song or performance.

The Quickest Way To Start a CD Is With the One Touch Operation

The power comes on, and operations are done automatically.

- Press the CD button.
- If there is a CD in the disc tray of the selected (The Disc marker lights up) disc number, playback begins from the first track of that disc.
- If there is not a CD in the disc tray of the selected disc number, search starts for a disc tray with a CD. If a CD is found, playback begins from the first track of that disc.
- If there is no CD in any of the disc trays, the message "NO DISC" appears in the display after a few seconds and the disc tray for DISC 1 opens.
- Press a DISC (1 to 3) button.
- If there is a CD in the disc tray for the disc number you have selected, playback begins from the first track of that disc. If there is no CD in the disc tray, the message "NO DISC" appears in the display after a few seconds and the disc tray opens.
- Press the ALL CD EJECT button.
- The Main Tray for all the disc trays opens.
- Press the \blacktriangle button.
- The Main Tray for the disc number corresponding to the number of the \blacktriangle button pressed, opens.

Basics of Using the CD Player — Continuous Play

You can play the discs continuously in the DISC 1 to DISC 3 trays.

To Insert Discs

To insert three discs at the same time:

1 Press the ALL CD EJECT button.

The Main Tray for all the disc trays opens. The disc trays are numbered from the top down; DISC 3, DISC 2, and DISC 1.

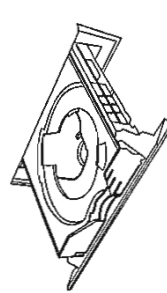

2 Insert a CD into the disc tray for DISC 3, with the label face-up.

ATTENTION: To avoid malfunctions when you play a CD, please set the CD in the right place at the center of the tray.

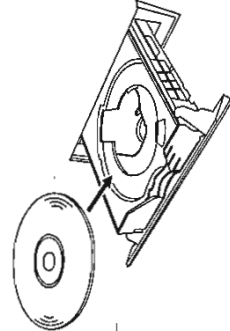

- To put an 8 cm CD into a tray, insert it so that it is aligned with the groove in the tray's center.

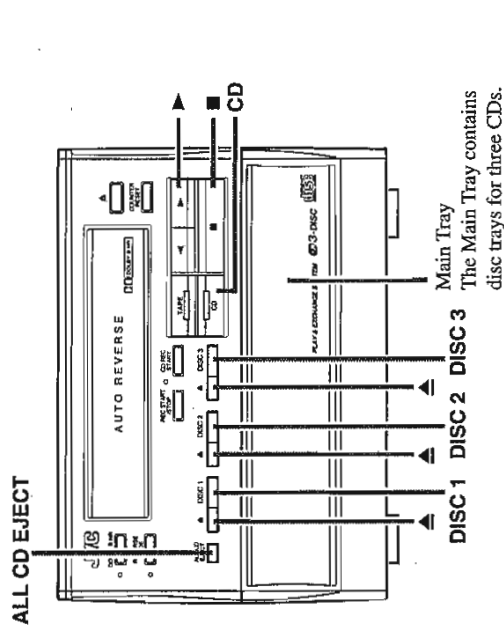

CD
Press this to select the CD as the playback source. The button indicator lights up and the \blacktriangle button, \blacksquare button and the cursor keys operate in CD control mode.

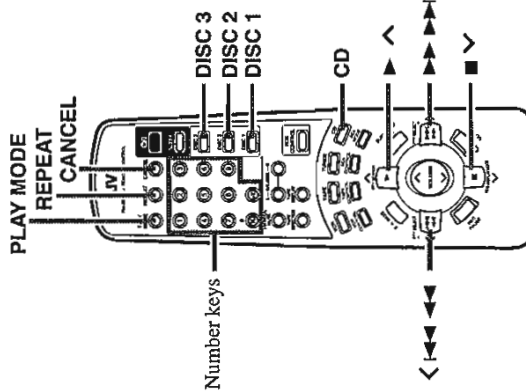
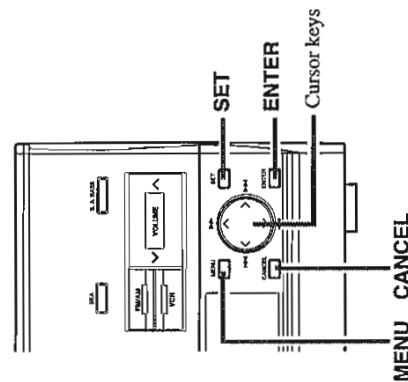

Display

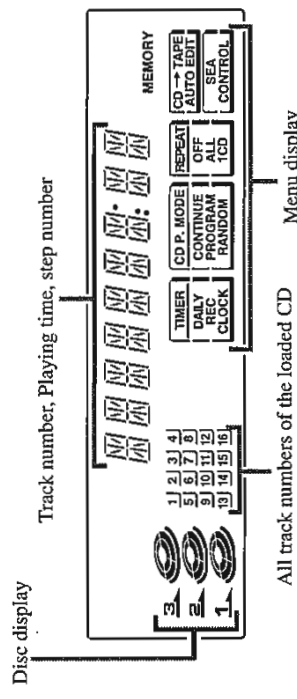

CD button

Press this button to select the CD as the playback source and switch the Remote Control CD control mode.

This illustration shows the Remote Control for CA-TD55R. The Remote Control for CA-TD5 does not have the RDS CONTROL button or include any RDS related labels.

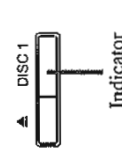

DISC button indicator

The buttons DISC 1, DISC 2, and DISC 3 act as indicators for the corresponding trays. This indicator is off when the CD Player is checking that there is no disc in the disc tray for the selected disc number. Pressing the \blacktriangle button turns the indicator on.

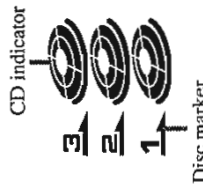

Disc display

A disc marker lights on the disc display for the disc number you have selected. The CD indicator blinks while a CD is being played. The CD indicator, for the disc tray corresponding to the "NO DISC" display, goes out. The CD indicator for the disc tray which is opened with the Main Tray lights up. The CD indicator for disc that have been played are dimmed slightly compared to discs that have still to be played, or are being played.

3 Push the disc tray for DISC 3 to the back.

Push the disc tray gently to the back using the finger hold on the front right of the tray. The disc tray for DISC 2 will appear below the disc tray for DISC 3.

- Take care not to touch any CDs in the lower trays when pushing the disc tray into the Unit.
- If excessive force is applied to the Main Tray, the Main Tray will be closed. So, when you push the disc tray, gently push it to the back.
- While pushing the disc tray, take care not to touch any buttons on the Unit.

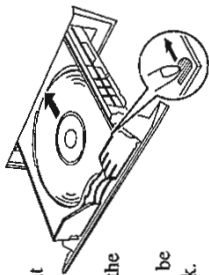

4 Insert a CD into the disc tray for DISC 2 in the same way as for DISC 3.

After inserting the CD, push the disc tray to the back. The disc tray for DISC 1 will appear.

5 Insert CD into the disc tray for DISC 1.

6 Press the ALL CD EJECT button.

The Main Tray returns to its original position.

- "ALL EJECT" appears on the display when the Main Tray is opened, and "ALL CLOSE" appears when it closes.
- If you press the CD or ► button on the unit (CD button on the Remote Control) instead of the ALL CD EJECT button, the Main Tray is automatically closed and continuous play starts for the lit disc marker. Also, if you press the DISC 1 - 3 buttons, the Main Tray will automatically close and playback will start from that disc.
- If the Main Tray is open when the System switches to standby mode, the Main Tray is closed automatically.

CAUTION: Do not push the disc tray for DISC 1 to the back. If the Main Tray is pushed in with a CD in, the tray will not load properly or may be ejected again after it has been pushed in. This can result in you not being able to use the CD Player. If the CD Player does not respond, disconnect the power cord then reconnect it again. The CD Player will operate normally again.

CAUTION: While closing the Main Tray, take care not to nip any foreign matter (headphone cable, etc.) between the Main Tray cover and the CD Player. If a foreign matter is nipped, the CD Player may be inoperative. In this case, remove it, and push the Main Tray cover to close the Main Tray. Then, the CD Player will operate normally again.

To insert CDs individually:

1 Press the ▲ button on the left of the DISC (1 - 3) button you want to insert the disc into.

The disc tray for the selected disc number is set to the top and the Main Tray opens.

2 Place a CD onto the tray.

3 Press the same ▲ button again.

The Main Tray closes.

- If you press a different ▲ button, the Main Tray closes then the disc tray for the ▲ button pressed is opened.
- If you press the ALL CD EJECT button, the Main Tray closes. Then the Main Tray opens again, containing all disc trays.

- "D1 OPEN" appears on the display when the Main Tray is opened (when DISC 1 is selected), and "D1 CLOSE" appears when it closes.

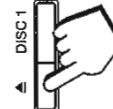
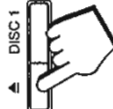

To Play a Disc

This function plays the disc in the Unit continuously, and lights the "CONTINUE" indicator.

1 Prepare the discs.

2 Press the DISC (1-3) button on the Unit or the Remote Control you want to play.

The first track of the selected disc will begin playing. When the selected disc finishes playing, the next disc will begin playing automatically. When the last disc has finished playing, the Unit will stop automatically.

To use Continuous Play from the first track of the disc selected by the disc marker, you do not need to press a DISC (1-3) button, just press the CD or ► button (or CD or ► ▲* button on the Remote Control).

* The ► ▲ button on the Remote Control can be used to control the CD Player when the Remote Control is in CD mode.

Playing order of discs

- When playback starts from DISC 1, the playing order is DISC 1 → DISC 2 → DISC 3. When DISC 3 has finished, the CD Player selects DISC 1 (the disc marker is on) and stops.
- When playback starts from DISC 2, the playing order is DISC 2 → DISC 3 → DISC 1. When DISC 1 has finished, the CD Player selects DISC 2 (the disc marker is on) and stops.
- When playback starts from DISC 3, the playing order is DISC 3 → DISC 1 → DISC 2. When DISC 2 has finished, the CD Player selects DISC 3 (the disc marker is on) and stops.
- If any of the disc trays are empty, the CD Player skips that disc tray and continues through the remaining disc trays in the order shown above.

Note: If there is no CD in the disc tray for the DISC (1-3) button you pressed, the message "NO DISC" appears on the display and the tray for that disc is automatically moved to the top and the Main Tray opens. If there is no disc in the disc tray for the selected disc number when the ► or CD button (or the CD or ► ▲ button on the Remote Control) is pressed, playback begins from the next disc.

To stop playing the disc, press the ■ button (press the ■ ▼ button after pressing the CD button when using the Remote Control).

To stop play and remove the disc, press the ▲ button for the disc being played or press the ALL CD EJECT button.

To pause, press the ► button. The Disc display will blink. (The Pause function cannot be used with the ► ▲ button on the Remote Control.)

To cancel pause, press the ► button again or press the CD button (or the CD or ► ▲ button on the Remote Control). Play continues from the point where it was paused.

To Change Discs While Playing

You can replace a CD in a tray not being used, while another CD is playing.

1 Press the ▲ button of the tray not being used.

The disc tray you selected is set to the top and the Main Tray opens.

2 Replace the disc in the tray.

3 Press the same ▲ button again.

The Main Tray closes.

To Select a Track

Press the cursor key to the right or left (◀◀ or ▶▶).

Set the tracks by pressing the ◀◀ ◀ or ▶ ▶▶ cursor key to move between tracks.

- Pressing the ▶▶▶ cursor key moves to the next track.
- Pressing the ◀◀◀ cursor key moves to the previous track. (Moves to the beginning of the track during playing a track.)

Pressing down either of these cursor keys scans the tracks continuously until the key is released.

Using the Remote Control

Press the ◀◀◀ or ▶▶▶ button after pressing the CD button.

- Each time you briefly press and release the ◀◀◀ or ▶▶▶ button, the track changes by one.
 - Press and release the ▶▶▶ button to go ahead one track at a time.
 - Press and release the ◀◀◀ button to go back one track at a time. (Moves to the beginning of the track during playing a track.)
- Holding down the ◀◀◀ or ▶▶▶ button allows you to change tracks continuously.

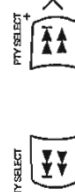
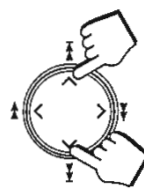

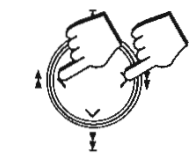

To Select a Passage Within a Track
Press the up or down cursor key continuously while a CD is playing.
 Pressing the up (▲▶) cursor key advances the CD rapidly, pressing the down (▼◀) cursor key plays the CD backwards rapidly. Release the cursor key at the point at which you wish to resume normal playback.

Note: You cannot perform these fast forwards or fast backwards operation with the Remote Control.

Locating a Track With the Remote Control Directly

Using the number keys on the Remote Control allows you to go directly to the beginning of any track.

1. Press the DISC (1-3) button for the disc tray containing the track you want to listen to.

- Example: for the third disc, press the DISC 3 button.

2. Enter the number of the track you want to listen to with the number keys.

The selected track starts playing.

- Example: for track 5, press 5. For track 15, press +10 then 5. For track 20, press +10, then 10. For track 32, press +10 three times, then 2.

Programming the Playing Order of the Tracks

You can change the order in which the discs and tracks play, and select only the discs and tracks you want from among those loaded in the CD Player.

- You can program up to 32 steps in any desired order from among the discs in the player.
- You can only make or change a program when the CD Player is stopped.

Using the Unit

1. Press the MENU button.

The TIMER section of the menu display blinks.

2. Press the cursor key to the right or left (◀◀ or ▶▶) and select "CD P.MODE".

The menu display changes with each press of the cursor keys as shown below.

- ← Press the left (◀◀) cursor key
 → Press the right (▶▶) cursor key

3. Press the cursor key to the up or down (▲▶ or ▼◀) and select "PROGRAM".

The menu display changes with each press of the cursor keys as shown below.

- ← Press the up (▲▶) cursor key
 → CONTINUE ↔ PROGRAM ↔ RANDOM ↔
- Press the down (▼◀) cursor key →

"PROGRAM" appears on the display.

4. Press the SET button.

The blinking "PROGRAM" display changes to a steady display.

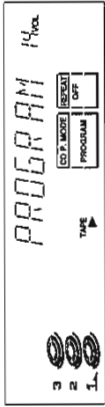
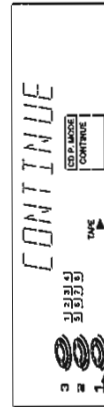
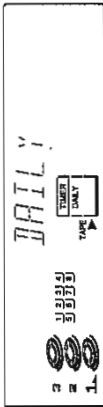
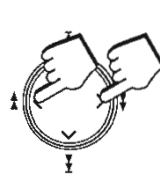
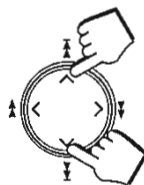
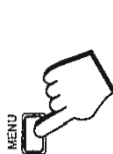

5. Press the cursor key to the up or down (▲▶ or ▼◀) to select the disc.

The display changes to the Program Entry display and the disc number and track number sections blink for a few seconds.

The menu display changes with each press of the cursor keys as shown below.

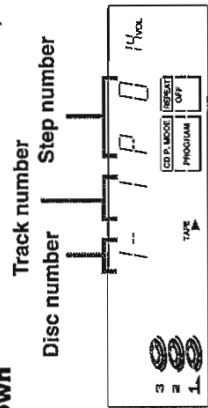

← Press the up (▲▶) cursor key

1 ↔ 2 ↔ 3

Press the down (▼◀) cursor key →

- If you press the DISC (1-3) buttons instead of pressing the up or down (▲▶ or ▼◀) cursor key, you can select the disc.
- While the display is blinking, perform the operations in steps 6 to 7. When the blinking display changes to the "PROGRAM" display, repeat the operations in steps 5 to 7.

6. Press the cursor key to the right or left (◀◀ or ▶▶) to select the track.

The track number appears on the display.

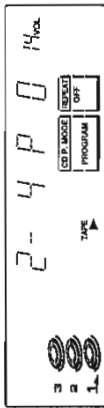

7. Press the SET button.

The blinking disc number and track number changes to a steady light, and the step number is displayed.



8. Repeat steps 5 to 7 to select the other tracks for the program.

- To select another track from the same disc, repeat the procedure from step 6.

9. Press the ▶ or CD button.

The Unit plays the tracks in the order you have programmed them.

Using the Remote Control

1. Press the PLAY MODE button to select PROGRAM.

"PROGRAM" lights up on the display.

The display changes with each press of the PLAY MODE button as below.

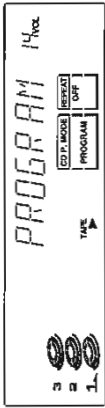

→ CONTINUE → PROGRAM → RANDOM → (back to the beginning)

2. Select a disc with the DISC (1-3) buttons.

The display changes to the Program Entry display and the disc number and track number sections blink for a few seconds.

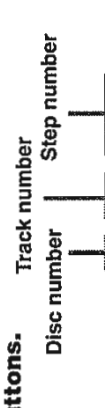

• While the display is blinking, perform the operations in step 3. When the blinking display changes to the "PROGRAM" display, repeat the operations in steps 2 to 3.

3. Press the number keys (1 to 10 and +10) to select the track to program.

- Example: For track 5, press 5. For track 15, press +10 then 5. For track 20, press +10 then 10. For track 32, press +10 three times, then 2.

The blinking disc number and track number changes to a steady light, and the step number is displayed.

4. Repeat steps 2 to 3 to select the other tracks for the program.

5. Press the ▶ or CD button.

The Unit plays the tracks in the order you have programmed them.



- If you try to program a 33rd track, the System lets you know that the program is full by displaying the message "FULL" on the display.
- If you try to program a disc tray that is empty, or a track number that does not exist on a disc (for example, selecting track 14 on a disc that only has 12 tracks), the selected disc or track are skipped when the program is played.
- You can skip to a particular step in a program during program play. Using the unit, press the right or left (← or →) cursor key, to this from the Remote Control, press the < or > cursor key or << or >> button.
- You can also repeat a step in a program. See page 27 "Repeating a Track or the Discs".

To stop playing, press the ■ button.
To delete all the tracks in a program, press the CANCEL button on the Unit repeatedly until all the tracks in the program have been deleted, or press the ALL CD EJECT button.
To exit Program mode, press the PLAY MODE button on the Remote Control and select CONTINUE, or press the MENU button on the Unit and use the cursor keys to select CONTINUE in CD P.MODE.

To Check the Program

While the CD Player is stopped, use the < or > cursor key or << or >> button on the Remote Control to check the contents of the program.
 Each time you press the << or >> button on the Remote Control, the program contents are shown on the display in the programmed order. Pressing the < or > button on the Remote Control displays the previous step in the program.

To Modify the Program

Modify the contents of a program while the CD Player is stopped.
 Press the CANCEL button on the Unit, the last track in the program is deleted.
 Each time you press the button, the last track listed in the program is deleted from the program.
 To add a track to the program, follow the procedure above (on either the Unit or the Remote Control). The new tracks are added to the end of the program.

Random Play

- The tracks will play in no special order when you use this mode.
- You can use this mode when the CD Player is stopped.

Using the Unit

- Press the MENU button.**
The TIMER section of the menu display blinks.
- Press the cursor key to the right or left (← or →) and select "CD P.MODE".**
The menu display changes with each press of the cursor keys as shown below.
 ← TIMER ↔ CD P.MODE ↔ REPEAT ↔ AUTO EDIT ↔ SEA CONTROL ↔
 Press the right (>) cursor key →
 Press the left (←) cursor key ←
 Press the cursor key to the up or down (▲ or ▼) and select "RANDOM".
 The menu display changes with each press of the cursor keys as shown below.
 ← CONTINUE ↔ PROGRAM ↔ RANDOM ↔
 Press the up (▲) cursor key
 Press the down (▼) cursor key →
 "RANDOM" appears on the display.
- Press the SET button.**
The blinking "RANDOM" display changes to a steady display.

- **Press the ► or CD button.**
The tracks are played in random order.
When all of the tracks have been played, the CD Player stops.

Using the Remote Control

- Press the PLAY MODE button to select RANDOM.**
"RANDOM" lights up on the display.
The display changes with each press of the PLAY MODE button as shown.
 → CONTINUE → PROGRAM → RANDOM → (back to the beginning)
- Press the ► or CD button.**
The tracks are played in random order.
When all of the tracks have been played, the CD Player stops.
Note: Press the DISC (1-3) buttons, or the number keys, to cancel Random play and begin playback in Continuous Play mode.
 ■ To instruct the CD Player to continue with a different random selection after the current setting has finished before starting random play, or while a random selection is playing, see page 27 "Repeating a Track or the Discs".
 To skip to the next track in the random program, press the > cursor key or >>> cursor key or >>>> cursor key on the Remote Control.
 To cancel random play, press the ■ button, then press the PLAY MODE button on the Remote Control to select another mode, or press the MENU button on the Unit and use the cursor keys to select a different mode.

Repeating a Track or the Discs

You can have all the discs, the program or the individual track currently playing repeat as many times as you like.

Using the Unit

- Press the MENU button.**
The TIMER section of the menu display blinks.
- Press the cursor key to the right or left (← or →) and select "REPEAT".**
The menu display changes with each press of the cursor keys as shown below.
 ← TIMER ↔ CD P.MODE ↔ REPEAT ↔ AUTO EDIT ↔ SEA CONTROL ↔
 Press the right (>) cursor key →
 Press the left (←) cursor key ←
 Press the cursor key to the up or down (▲ or ▼) and select Repeat mode.
 The menu display changes with each press of the cursor keys as shown below.
 ← Press the up (▲) cursor key
 → ALL ↔ 1 CD ↔ 1 ↔ OFF ↔
 Press the down (▼) cursor key →
- Press the SET button.**
Repeats all the tracks on the CD's in the CD Player, or all the tracks in the program.
 1: Repeats one track on a CD.



Using the Remote Control
Press the REPEAT button.

The display changes with each press of the button, as shown below.

→ ALL → 1 CD → 1 → OFF → (back to the beginning)

- "REPEAT ALL" and "REPEAT 1" remain on the display even when you change the CD play mode.
- The three Repeat Modes above can be selected during Continuous Play, however, during Program Play and Random Play, you can only select REPEAT ALL or REPEAT 1.

To exit Repeat Mode, select "OFF" in step 3.

Tray Lock Function

In order to safely keep the discs in the CD Player, the three trays can be electronically locked in a single operation. When the electronic lock is on, the trays cannot be opened even if the or ALL CD EJECT button is pressed.

This function can only be accessed by using the buttons on the Unit itself.

Locking the Electronic Lock

- Put the System's power into STANDBY mode.**
- While pressing the button, press the DISC 1's button.**
"LOCKED" appears on the display to let you know that the trays have been locked.

LOCKED

When the CD Player trays are locked, pressing the or ALL CD EJECT buttons displays the message "LOCKED" on the display and the trays do not open. And the or ALL CD EJECT button can not be used to automatically turn on the power.

Unlocking the Electronic Lock

- Put the System's power into STANDBY mode.**
- While pressing the button, press the DISC 1's button.**
When the unlock operation is done, "UNLOCKED" appears in the display to show that the lock has been taken off.

UNLOCKED

The trays can now be opened by pressing the or ALL CD EJECT button. The and ALL CD EJECT buttons can also be used to automatically turn on the power.

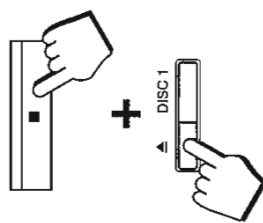

Using the Cassette Deck
(Listening to a Tape)

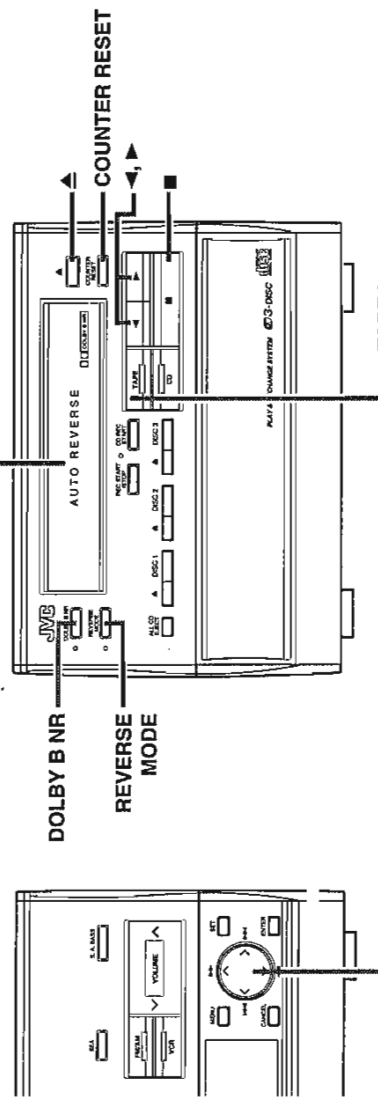

Cursor keys

This illustration shows the Remote Control for CA-TD55R. The Remote Control for CA-TD5 does not have the RDS CONTROL button or include any RDS related labels.

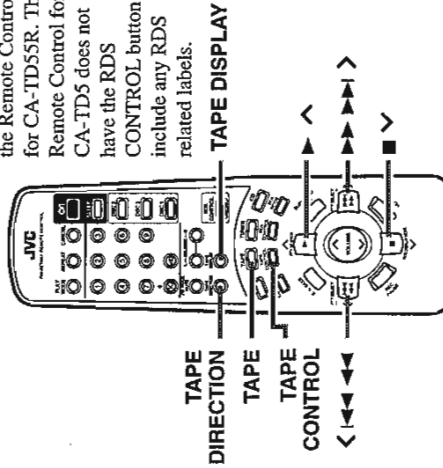

TAPE button and TAPE CONTROL button
Press the TAPE or TAPE CONTROL button to switch the Remote Control to Cassette Deck control mode. You can then use the , , , and buttons to control the Cassette deck.

Display

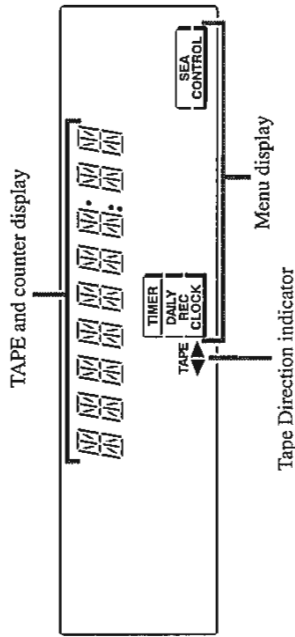

When the System is being used, the display shows other items as well. However, we have only shown the items described in this section. This illustration shows only the Menu display items for the Cassette Deck.

The Cassette Deck allows you to play and record audio tapes.

- Most tapes are now recorded with the Dolby NR system, so first check which type of the Dolby NR system has been used on the tape. Only Dolby B NR is incorporated into the System.
- With Automatic Tape Detection, you can listen to type I or II tapes without changing any settings.

The use of tapes longer than 120 minutes is not recommended, since characteristic deterioration may occur and these tapes easily jam in the pinch-rollers and the capstans.

One Touch Play
Press the TAPE button (on the Unit or on the Remote Control).
Press the button on the Remote Control.(When the Remote Control is in Cassette deck control mode)

The power comes on and "TAPE" lights up on the display. If there is a tape in the Tape Tray, the tape is automatically played. If there is no tape in the Tape Tray, "OPEN" appears on the display and the Tape Tray opens.



Regular Play

If the power is already on, you can use this basic procedure:

1. **Press the \blacktriangle button.**
"OPEN" appears on the display and the Tape Tray opens.
2. **Insert a tape into the Tape Tray with the tape head at the back.**
3. **Press the \blacktriangle button again.**
"CLOSE" appears on the display and the Tape Tray closes.
4. **Press the TAPE button.**
The tape is played in the direction shown by the Tape Direction indicator.
 - If the Tape Tray is open, it automatically closes and the tape is played when you press the TAPE button.
 - If the Cassette Deck is already selected as the playback source, press the \blacktriangle or \blacktriangleright button to play the tape in that direction.
 - If the Remote Control is in Cassette Deck control mode, press the \blacktriangle or \blacktriangleright button on the Remote Control to play the tape in the direction shown by the Tape Direction indicator.

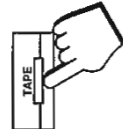

To stop playing, press the \blacksquare button on the Unit or press the \blacktriangledown button on the Remote Control after switching to Cassette deck control mode.

To remove the tape, press the \blacktriangle button. The tape automatically stops and the Tape Tray opens.

To change the direction of playback for the tape, press the \blacktriangle or \blacktriangleright button. If you are using the Remote Control, press the TAPE DIRECTION button.

Tape Direction Indicator and the Display

Tape Direction Indicator

The Tape Direction indicator shows you which direction the tape is being played in. The direction of playback and the Tape Direction indicator display are shown below.

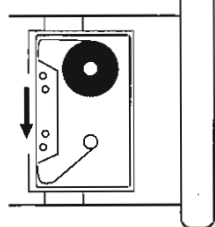

When the indicator is \blacktriangleright

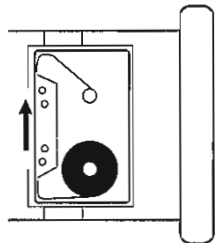

When the indicator is \blacktriangleleft

- During playback, the Tape Direction indicator blinks slowly. During fast left or fast right, the indicator blinks quickly. During Music Scan mode, the direction indicator alternates between blinking slowly and quickly repeatedly.

Display

The display includes a tape counter which shows you which direction a tape is being played. The tape counter increases when the tape is playing in the \blacktriangleright direction, and decreases when the tape is played in the \blacktriangleleft direction.

- When the Tape Direction indicator shows \blacktriangleright , the counter increases when you fast forward a tape and decreases when you rewind a tape.
- When the Tape Direction indicator shows \blacktriangleleft , the counter decreases when you fast forward a tape and increases when you rewind a tape.
- When the Tape Direction indicator shows \blacktriangleright , the following happens when you do a Music Scan.
 - When you scan to the next selection, the counter increases.
 - When you scan to the previous selection, the counter decreases.
- When the Tape Direction indicator shows \blacktriangleleft , the following happens when you do a Music Scan.
 - When you scan to the next selection, the counter decreases.
 - When you scan to the previous selection, the counter increases.

To reset the tape counter, press the COUNTER RESET button. The counter returns to "0000".

TAPE 0000



Fast Forward and Rewind

Press the \blacktriangleright or \blacktriangledown cursor key.

- When the Tape Direction indicator shows \blacktriangleright , the tape fast forwards when you press the \blacktriangleright key and rewinds when you press the \blacktriangledown key.
- When the Tape Direction indicator shows \blacktriangleleft , the tape rewinds when you press the \blacktriangleright key and fast forwards when you press the \blacktriangledown key.
- When using the Remote Control, press the \blacktriangleleft or \blacktriangleright button while the tape is stopped after pressing the TAPE or TAPE CONTROL button.

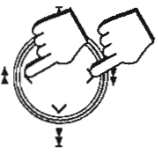

Music Scan

To find the beginning of a music selection, use the Music Scan function. Music Scan searches for blank portions that usually separate selections, then plays the next selection.

Press the \blacktriangleleft or \blacktriangleright cursor key.

- When the Tape Direction indicator shows \blacktriangleright . Press the \blacktriangleright button to scan to the previous selection. Press the \blacktriangleleft button to scan to the next selection. Press the \blacktriangleleft or \blacktriangleright button to scan to the previous selection.
- When the Tape Direction indicator shows \blacktriangleleft . Press the \blacktriangleleft button to scan to the next selection. Press the \blacktriangleright button to scan to the previous selection.
- When using the Remote Control, press the \blacktriangleleft or \blacktriangleright button while playing or Music Scanning after pressing the TAPE or TAPE CONTROL button.

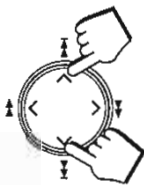

When you press the left or right cursor keys (\blacktriangleleft or \blacktriangleright) while the tape is stopped, the unit scans the first part of the selection in the corresponding direction and automatically plays the track.

Music Scan works by detecting a 4-second long blank at the beginning of each selection, so it won't work well if your tape has:

- No blank at the beginning of a selection.
- Noise (often caused by much use or poor quality dubbing) which fills the blank with noise.
- Long, very soft passages or pauses in a selection. The scan will detect these as 4-second long blanks. If this happens, just scan again until you reach the selection you want.

Other Useful Features of the Cassette Deck

Reverse Mode

Use Reverse Mode to make the tape automatically reverse at the end of a side and start playing the other side. Press the REVERSE MODE button to switch Reverse Mode on (the indicator lights up) or off (the indicator goes off).

When the Reverse Mode is set to off (the indicator goes off), the tape stops playing after being played on one side.



DOLBY B NR

Press the DOLBY B NR button to switch Dolby B Noise Reduction on (the indicator lights up) or off (the indicator goes off). If a tape is recorded with the Dolby B NR system, playing it back with the Dolby NR on will reduce tape noise and improve the clarity of the sound.



Dolby noise reduction manufactured under license from Dolby Laboratories Licensing Corporation. "DOLBY" and the double-D symbol are trademarks of Dolby Laboratories Licensing Corporation.

To Control the Cassette Deck While Another Source is Being Played

You can use the Remote Control to rewind or fast forward a tape while another source is being played.

1. **Press the TAPE CONTROL button.**

The Remote Control switches to Cassette Deck control mode.

2. **Press the \blacktriangleleft or \blacktriangleright button to rewind or fast forward the tape.**



Note: You cannot use any other Cassette Deck controls, apart from fast forward and rewind, while another source is being played.

Using the Cassette Deck (Recording)

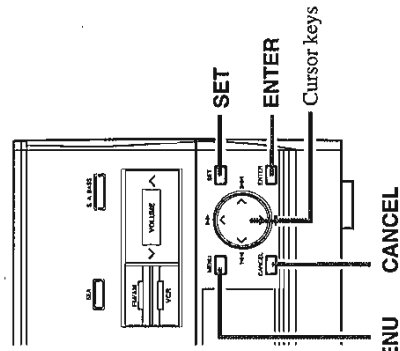

This illustration shows the Remote Control for CA-TD55R. The Remote Control for CA-TD5 does not have the RDS CONTROL button or include any RDS related labels.

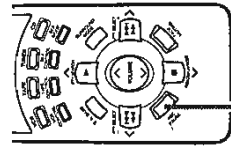

REC PAUSE

Display

When the System is being used, the display shows other items as well. However, we have only shown the items described in this section.

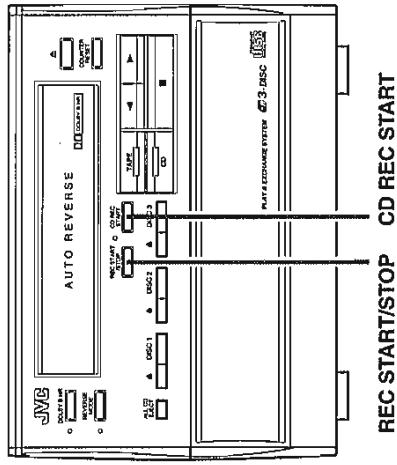

REC START/STOP CD REC START

Recording onto a cassette from any of the sound sources is simple. Just place a tape in the Tape Tray, have the source ready, make one or two settings, and you're ready to record. For each source the procedure is a little different and now we'll explain just what to do for each one. If you forget, just come back to the section which has the specific procedures you need. But first, here are a few things to make your recordings better.

Things To Know Before You Start Recording

- It may be unlawful to record or play back copyrighted material without the consent of the copyright owner.
- Press the DOLBY B NR button — the indicator lights up — to reduce tape hiss.
- When you want to record onto both sides of a tape, you can set Reverse mode on to do so. However, recording automatically stops after recording in the ◀ direction in Reverse mode. Therefore, make sure that the tape direction is ▶ when recording with Reverse mode on.
- The recording level, which is the volume at which the new tape is being made, is automatically set correctly, so it is not affected by the VOLUME control on the System. Thus, during recording you can adjust the sound you are actually listening to without affecting the recording level.
- Two small tabs on the back of the cassette tape, one for side A and one for side B, can be removed to prevent accidental erasure or re-recording. To record on a cassette with the tabs removed, you must cover the holes with adhesive tape first. However, when a type II tape is used, only cover part of the hole as shown, since the other part of the hole is used to detect the tape type.
- When recording, you can hear Sound Mode effects through the speakers or headphones. However, the sound is recorded without Sound Mode effects.
- Type I and Type II tapes can be used for recording.

Note: At the start and end of cassette tapes, there is leader tape which cannot be recorded onto. Depending on the recording source, the first part of the recording may be missing because of the leader. When recording CDs or radio broadcasts, to get the beginning of the recording on the tape, first wind on the leader before beginning recording.

CAUTION: If recordings you have made have excessive noise or static, the Unit may be too close to a TV which was on during the recording. Either turn off the TV or increase the distance between the TV and the System.

Standard Recording

This is the basic method for recording any source. The System also has special ways for recording CD to tape which save you time and effort, as well as give you some special effects. However, when you need to add a selection to a tape you have made, or are combining selections from several sources on one tape, use the method described below; just substitute the source you want into this procedure, such as a CD or the Tuner. You can also record from VCR with this procedure.

To Record Any Sound Source To Tape

1. **Insert a blank or erasable tape into the Tape Tray. (See page 30.)**
2. **When recording on both sides of a tape, set Reverse Mode to on (the indicator lights up).**
 - If you are recording while Reverse Mode is on, insert the tape so that it will be recorded in the forwards ▶ direction. (See page 30.)
3. **Check the recording direction for the tape.**

Check that the Tape Direction indicator is the same as that for the tape in the Tape Tray. If the directions are different, press the ◻ button after pressing the ◀ or ▶ button to set the tape direction. (When using the Remote Control, press the TAPE DIRECTION button to synchronize the tape direction.)

 - If you are recording while Reverse Mode is on, check that the Tape Direction indicator is in the forwards ▶ direction then press the ◻ button. (When using the Remote Control, press the TAPE DIRECTION button so that the Tape Direction indicator is in the ▶ direction.)
4. **Prepare the source, by, for example, tuning in a radio station, loading CDs, or turning on connected equipment.**
5. **Press the REC START/STOP button.**

The recording indicator blinks and the System begins to record.

Notes for using Reverse Mode for recording

If you are recording while Reverse Mode is on, the System automatically stops when it reaches the end of the reverse ◀ direction. To record on both sides of a tape, make sure that the recording direction for the tape inserted into Tape Tray is forwards ▶, and that the Tape Direction indicator is also forwards ▶, before you start recording.

To Pause at Any Time During the Recording

Press the REC PAUSE button after pressing the TAPE CONTROL button on the Remote Control. The Recording indicator changes from a blinking display to a steady display. To continue the recording, press the REC START/STOP button on the Unit or the ▶ ◻ button after pressing the TAPE CONTROL button on the Remote Control.

To Stop at Any Time During the Recording Process

Press the REC START/STOP button on the Unit or the ◻ ◻ button after pressing the TAPE CONTROL button on the Remote Control.

Checking the Tape Counter While Recording

You can check the tape counter while you are recording.

Press the TAPE DISPLAY button on the Remote Control while recording.

The display changes from the source display to the counter display for about five seconds.

How to create a blank section on the tape

1. **Select the CD as a source and stop the CD.**
2. **Press the REC START/STOP button, to create a blank section on the tape.**
3. **After you have created a blank space, press the REC START/STOP button again to stop recording.**

If you are recording an AM (MW/LW) broadcast and you hear interference, move BEAT CUT switch on the back panel from position 1 (the normal mode) to position 2.

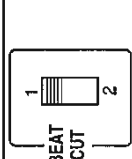

CD Direct Recording

Everything on the CD goes onto the tape in the order it is on the CD, or according to the order you have set in a program.

1. Prepare CDs. (See page 21.)

- Check that the CD Player is not playing a CD.
- Set the source to CD.

2. Insert a cassette into the Tape Tray to record on.

When you want to record on both sides of a tape, press the REVERSE MODE button to turn Reverse Mode on. Check that the recording direction for the tape and the Tape Direction indicator are correct. (See page 33 "Notes for using Reverse Mode for recording".)

3. Press the CD REC START button.

"CD REC START" appears on the display and the CD Player starts playing the first track to be recorded.

At the end of the tape, the System automatically goes back to the beginning of the last selection and records it; this time gently fading out at the end. If you selected the Reverse Mode, the reverse side starts with the last selection on the first side and will be faded out at the end again. (About 10 second blank is created at the beginning of the reverse side.) When the recording is finished, the message "CD REC FINISHED" scrolls by on the display. The CD Player and Cassette Deck stop.

To Stop at Any Time During the Recording Process

Press the REC START/STOP or ■ button. The recording stops when you press the REC START/STOP button. If you press the ■ button, the unit creates a four second blank section of tape before stopping.

Note: When making SLEEP timer settings while doing CD Direct recording, set the time so that there is enough leeway to finish the recording before the power goes off. If the time is set to about the length of the CD, the power may go off before recording finishes.

For CD Direct Recording using more than one disc, use a blank tape. If you use a prerecorded tape, prerecorded material may not be erased between newly-recorded tracks.

Auto Edit Recording

Using Auto Edit, you can record the CD tracks to fit the tape, so a selection isn't cut off. Auto Edit is one of the best ways to copy all of a CD onto a tape. Auto Edit programs the CD tracks in numerical order. To prevent the end of the last track on the first side from being cut off, the last track on the first side is selected to fit on the remaining tape length.

1. Prepare the CD or CDs. (See page 21.)

- Set the source to CD and check that the CD Player is not playing a CD.

2. Press the MENU button.

The "TIMER" section of the menu display blinks.

3. Press the cursor key to the right or left (← or →) and select "AUTO EDIT".

The display changes with each press of the cursor keys as shown below.

- ← Press the left (←) cursor key
- ↔ TIMER ↔ CD P.MODE ↔ REPEAT ↔ AUTO EDIT ↔ SEA CONTROL ↔
- Press the right (→) cursor key →

- You cannot select AUTO EDIT if a source other than the CD Player is selected.

4. Press the SET button.

"DISC" blinks on the display.

5. Press the cursor key up or down (▲ or ▼) and select the disc.

The display changes with each press of the cursor keys as shown below.

- ← Press the up (▲) cursor key
- 3 ← 2 ← 1
- Press the down (▼) cursor key →

- If you press the DISC (1-3) buttons instead of pressing the up or down (▲ or ▼) cursor keys, you can select the disc.

6. Press the SET button.

After "TAPE C -" appears on the display, the display shows you the length of tape required to record the CD you selected.

- You can select a different length of tape, depending on the actual size of the tape you are using, from eleven possibilities programmed into the System: 40, 46, 50, 54, 60, 64, 70, 74, 80, 84, 90. Use the ← or → key to select the length that matches the length of tape you will be using, or the length nearest to the length you will be using.
- If you pick a tape length shorter than the total playing time of the CD, the last tracks on both sides of the tape will be faded out as the tape ends.

7. Press the SET button.

"SIDE-B" blinks on the display and the tracks that will be recorded on side B of the tape are displayed.

- To display the tracks that will be recorded on side A of the tape, press the SET button again. The Unit switches between side A and side B with each press of the SET button.

8. Press the ENTER button.

9. Insert a cassette in Tape Tray to record on.

When you want to record on both sides of a tape, press the REVERSE MODE button to turn Reverse mode on.

10. Press the CD REC START button.

The Unit plays the CD and starts recording. If the tape has not been rewound, the Unit rewinds the tape before starting to record the CD.

When the tape is ready, to prevent the start of a track being cut, the System creates a blank period of about 10 seconds before it starts to record the CD. While a blank period is being created, "TAPE SIDE-A STANDBY" scrolls through the display. (The System also creates about 10 second blank period at the start of side B of the tape. While a blank period is being created, "TAPE SIDE-B STANDBY" scrolls through the display.)

When the recording is finished, the message "CD REC FINISHED" scrolls by on the display. The CD Player and Cassette Deck stop.

To stop at any time while recording, press the REC START/STOP button or the ■ button. The recording stops when you press the REC START/STOP button. If you press the ■ button, the unit creates a four second blank section of tape before stopping.

To cancel Auto Edit, press the ▲ button on the CD Player or the ALL CD EJECT button. You can also cancel Auto Edit by selecting play mode from the Unit or the Remote Control after stopping the recording.

Notes:

- If you change any of the CD's while using Auto Edit, Auto Edit will be cancelled. Therefore, do not change the CD's while using Auto Edit.
- When making SLEEP timer settings while doing Auto Edit recording, set the time so that there is enough leeway to finish the recording before the power goes off. If the time is set to about the length of the CD, the power may go off before recording finishes.

Using the Timer

This illustration is of CA-TD55R, CA-TD5 does not have the DISPLAY MODE, EON ON/OFF, TANNEWS/INFO, and PTY SEARCH buttons.

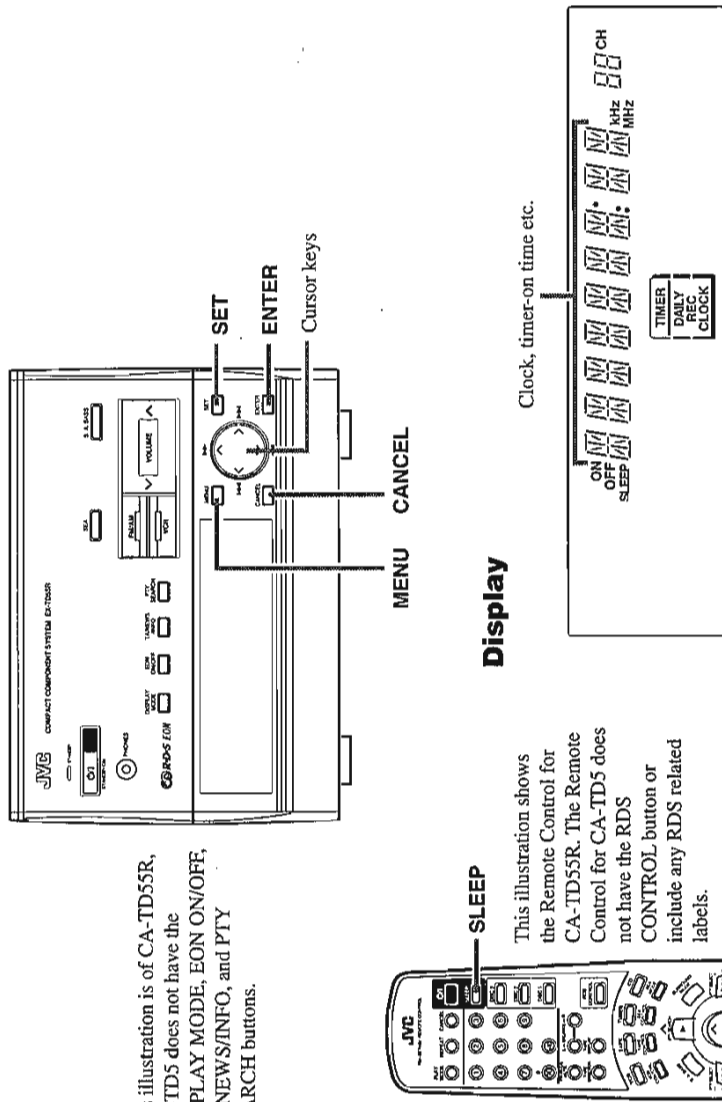

This illustration shows the Remote Control for CA-TD55R. The Remote Control for CA-TD5 does not have the RDS CONTROL button or include any RDS related labels.

Display

Clock, timer-on time etc.

When the System is being used, the display shows other items as well. However, we have only shown the items described in this section.

The timers lets you control recording and listening functions automatically.

Three types of timers are available:

- **DAILY Timer** --- Use this timer to set wake up everyday to music from any source, instead of an alarm clock.
- **ONCE REC (Recording) Timer** --- Unattended recording of radio broadcasts. You can set the starting time and length of the recording.
- **SLEEP Timer** --- Fall asleep and have your System turn off automatically after a certain length of time.

Note: If you try to select a Timer mode without setting the clock, "CLOCK" and "ADJUST" are displayed alternately on the display, and you will be unable to set the timer function. (See page 8 "Setting the Clock".)

Setting the DAILY Timer

With this timer you can wake up to music from a CD, tape, your favorite radio program.

- You can set the DAILY Timer whether the Unit is on or off.



1 Press the MENU button.

"DAILY" appears on the display and the DAILY indicator in the "TIMER" section of the menu display blinks.

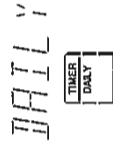

2



2 Press the SET button.

The display changes to the On Time display.



3

3 Set the On Time.

1. Set the hour by pressing the left or right cursor key.

Pressing the right cursor key increases the hour, and pressing the left cursor key decreases it. Pressing down either of these cursor keys adjusts the setting continuously until the key is released.

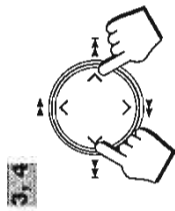

3.4

2. Press the SET button.

The minute digits on the display blink.

3. Set the minute by pressing the left or right cursor key.

Pressing the right cursor key increases the minute, and pressing the left cursor key decreases it. Holding down either of these cursor keys allows you to continuously adjust the minute setting in 10 minute increments until the key is released.



4

4. Press the SET button.

The On Time is set and the display changes to the Off Time setting.

4

4 Set the Off Time.

Use the cursor keys and the SET button to set the Off Time in the same way as for set the On Time. After the Off Time minute setting has been set, the display changes to source selection display.

5

5 Select the source you want to listen to.

To use the Tuner as the source.

1. Press the left or right cursor key until "TUNER" blinks on the display.

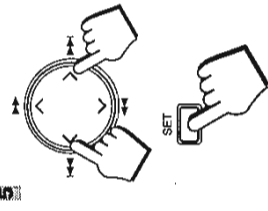

3

2. Press the SET button.

3. Press the left or right cursor key to select the preset channel you want to listen to.

You can only select a station to receive from amongst the preset channels.



4

4. Press the SET button.

Proceed to step 6.

5

5 To use a CD as the source

1. Press the left or right cursor key until "CD" blinks on the display.



2

2. Press the SET button.

"DISC -" blinks on the display.

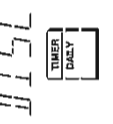

3

3. Press the left or right cursor key to select the disc you want to play.

- If you select "DISC -", the last CD that was played is selected.



4

4. Press the SET button.

"TRACK -" blinks on the display.



5

5. Press the left or right cursor key to select the track you want to play.

You can only select up to 20 tracks.

- If you select "TRACK -", play back starts for the first track of the CD.



To Turn the DAILY Timer On Again

1. **Press the MENU button.**
"DAILY" appears on the display and the DAILY indicator in the "TIMER" section of the menu display blinks.
2. **Press the SET button.**
3. **Press the ENTER button.**

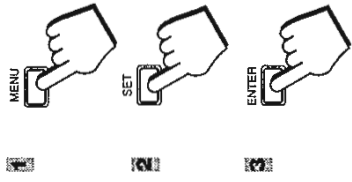

CAUTION: If the System is unplugged, or a power failure occurs, the timer setting will be erased in a few days. If the settings are erased in this way, reset the timer settings.

Setting the ONCE REC (Recording) Timer

With the Recording Timer you can make a tape of a radio broadcast automatically whether or not you are home. For the timer to work correctly, you need to make sure of the following in addition to setting the time for the Tuner and Cassette Deck to come on:

- You can set the ONCE REC Timer whether the Unit is on or off.
- The tape you want to record onto must be in Tape Tray.

1. **Press the MENU button.**
"DAILY" appears on the display and the DAILY indicator in the "TIMER" section of the menu display blinks.
2. **Press the up or down cursor key (▶▶ or ◀◀) until "REC" blinks on the display.**
"ONCE REC" appears on the display and the REC indicator in the "TIMER" section of the menu display blinks.
3. **Press the SET button.**
The display changes to the On Time display.

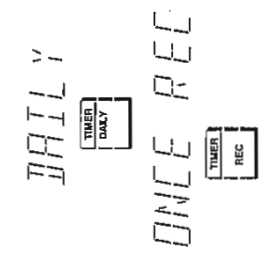

4. Set the On Time and Off Time.

Use the ◀◀◀ or ▶▶▶ key, and the SET key to set the start and end times in the same way as for the DAILY Timer.
When you press the SET button after setting the Off Time, "TUNER" starts to blink on the display.



5. Press the SET button.

The display changes to the preset channel selection screen.

6. Press the left or right cursor key (◀◀ or ▶▶) to select the preset channel you want to listen to.

You can only select a station to receive from amongst the preset channels.

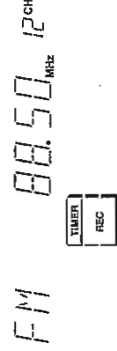

7. Press the ENTER button.

The "REC" indicator changes from a blinking display to a steady display. The ON TIME, OFF TIME, and preset channel number are displayed then the display reverts to the previous display, before the Timer was set.

Turn the power off if you made the timer settings with the power turned on.

- If you make a mistake while setting the Timer, press the CANCEL button to return to the previous setting. You can use the CANCEL button to return to the On Time setting.
- A few seconds before the start time for the timer, the System automatically turns on the power and displays "ONCE REC" and "TIMER" alternately on the display. When the set time is reached, playback starts using the selected source. A few seconds before the end time for the timer, "TIMER" blinks on the display and when the end time is reached the power is automatically turned off again.
- If you change the source while the ONCE REC timer is running, the timer operation is cancelled.

6. Press the SET button.

Proceed to step 6.

To use a Cassette Deck as the source

1. **Press the left or right cursor key (◀◀ or ▶▶) until "TAPE" blinks on the display.**



2. Press the SET button.

Proceed to step 6.

To Use the current source as the playback source:

1. **Press the left or right cursor key (◀◀ or ▶▶) until "----" blinks on the display.**

2. Press the SET button.

Proceed to step 6.

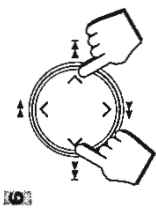

6. Setting the volume level.

Press the left or right cursor key (◀◀ or ▶▶) to adjust the volume level.

VOLUME - A: Sets the volume level to 5.

VOLUME - B: Sets the volume level to 12.

VOLUME - C: Sets the volume level to 20.

VOLUME - - - : Sets the volume to the last volume setting used.



7. Press the ENTER button.

The "DAILY" indicator changes from a blinking display to a steady display. The ON TIME, OFF TIME, PLAYBACK SOURCE (including the disc number and track number if a CD source is selected) are displayed then the display reverts to the previous display, before the Timer was set. Turn the power off if you made the timer settings with the power turned on.

- If you make a mistake while setting the Timer, press the CANCEL button to return to the previous setting. You can use the CANCEL button to return to the On Time setting.
- A few seconds before the start time for the timer, the System automatically turns on the power and displays "DAILY" and "TIMER" alternately on the display. When the set time is reached, playback starts using the selected source. A few seconds before the end time for the timer, "TIMER" blinks on the display and when the end time is reached the power is automatically turned off again.
- If you change the source while the DAILY timer is running, the timer operation is cancelled.



Before Turning Off the Unit

- If the source is a CD, make sure that there is a CD in the selected disc number.
- If the source is a tape:
 - Make sure that there is a tape in the Tape Tray.
 - Check that the tape direction is correct. This is important especially when Reverse Mode is off.
 - Set Reverse Mode on if you want to play both sides of the tape.
- Select the Sound Mode if you want to listen using a Sound Mode effect.

To change the DAILY Timer setting

To change the settings for the DAILY Timer, repeat the setting procedure from the beginning.

Turning the DAILY Timer On and Off

Once the DAILY Timer has been set, it will be activated at the same time every day until the setting is turned off.

To Turn the DAILY Timer Off

1. **Press the MENU button.**
"DAILY" appears on the display and the DAILY indicator in the "TIMER" section of the menu display blinks.



2. Press the CANCEL button.

"DAILY OFF" appears on the display and the DAILY indicator in the TIMER section of the menus goes out.

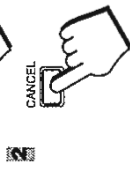

Before the Timer Starts

- Check that tape direction is correct. This is important especially when Reverse Mode is off.
- Set Reverse Mode on if you want to record on both sides of the tape.
- The VOLUME control is automatically set to 0 when ONCE REC Timer is recording.

It is very easy, and can be very disappointing, to forget to put in a tape, or to accidentally leave a tape in Tape Tray you don't want recorded over. Although this happens to almost everyone at one time or another, we hope it won't happen to you!

To Change the Recording Timer Setting

To change the settings for the ONCE REC Timer, repeat the setting procedure from the beginning.

Turning the ONCE REC Timer On and Off

Once the ONCE REC Timer has been used to record a source, the setting is maintained but the Timer is set to OFF.

To Turn the REC Timer Off Before the Timer Starts.

- Press the **MENU** button.
"DAILY" appears on the display and the DAILY indicator in the "TIMER" section of the menu display blinks.
- Press the **up or down cursor key** (▲ or ▼) until "REC" blinks on the display.
"ONCE REC" appears on the display and the REC indicator in the "TIMER" section of the menu display blinks.
- Press the **CANCEL** button.
"REC OFF" appears on the display and the REC indicator in the TIMER section of the menus goes out.

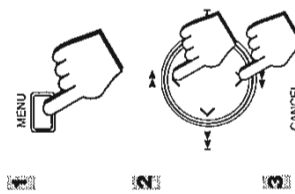

To Record at the Same Time Again.

- Press the **MENU** button.
"DAILY" appears on the display and the DAILY indicator in the "TIMER" section of the menu display blinks.
- Press the **up or down cursor key** (▲ or ▼) until "REC" blinks on the display.
"ONCE REC" appears on the display and the REC indicator in the "TIMER" section of the menu display blinks.
- Press the **SET** button.
- Press the **ENTER** button.
The DAILY indicator in the TIMER section of the menu changes from a blinking display to a steady display. The ON TIME, OFF TIME, and preset channel number are displayed then the display reverts to the previous display, before the Timer was set.

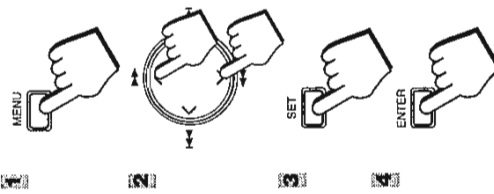

CAUTION: If the System is unplugged, or a power failure occurs, the timer setting will be erased in a few days. If the settings are erased in this way, reset the timer settings.

Setting the SLEEP Timer

Use the Sleep Timer to turn the Unit off after a certain number of minutes when it is playing. By setting this timer, you can fall asleep to music and know your Unit will turn off by itself rather than play all night.

- You can only set the Sleep Timer when the Unit is on and a source is playing.

To set the SLEEP Timer, follow this procedure:

- With the System on and a source playing, press the **SLEEP** button on the Remote Control.
The message "SLEEP" appears on the display.  SLEEP 10
- Set the length of time you want the source to play before shutting off.
Each time you press this button while the "SLEEP" indicator is blinking, it changes the number of minutes shown on the display in this sequence:
→ 10 → 20 → 30 → 60 → 90 → 120 → Cancelled → (back to the beginning)

When the number of minutes you want shows on the display, just wait 5 seconds until the "SLEEP" indicator stops blinking, and is lighted steadily.

The Unit is now set to turn off after the number of minutes you set.

To Change the SLEEP Timer Setting

Press the SLEEP button until the number of minutes you want appears on the display.

To Cancel the SLEEP Timer Setting

Press the SLEEP button until the "SLEEP" indicator goes off on the display. Turning off the Unit also cancels the SLEEP Timer.

Timer Priority

Since each timer can be set independently, you may wonder what happens if the settings overlap. Here are the priorities for each timer:

- The ONCE REC Timer always has priority. This means that:
 - If another timer is set to come on during a time when the ONCE REC Timer is operating, the other timer just won't come on at all, so you will always get the entire program on tape.
 - If the ONCE REC Timer is set to come on while another timer is operating, the other timer will shut off 10 seconds before the ONCE REC Timer is set to turn on, and the ONCE REC Timer will then take over.
- The SLEEP Timer has the least priority. This means that if the SLEEP Timer is set while the DAILY Timer is operating, the DAILY Timer settings are cancelled. However, if the DAILY Timer is set to come while the SLEEP Timer is operating, the SLEEP Timer setting will be cancelled and the Unit will use the settings from the DAILY Timer.

Example 1

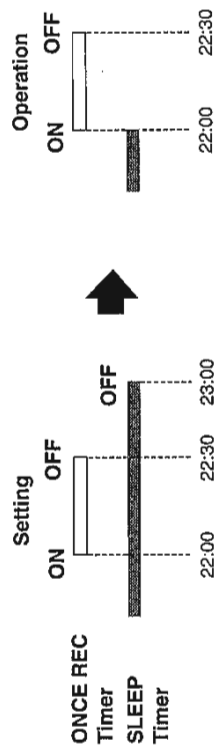

Example 2

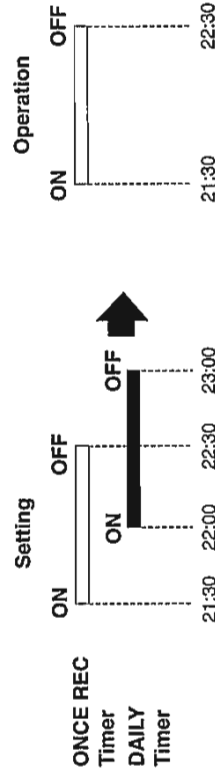

- 3. Press the **▶ ^** button on the Remote Control.
- 4. Adjust the **VOLUME** control to the desired listening level.
- 5. Select a sound effect mode, if you wish.

To stop playing, press the **■ ∨** button.

To Cancel the Setting

Change the source by starting any one of the System's built-in sound sources, such as the Tuner or CD Player.

Recording of a JVC VCR

- 1. **Prepare the VCR for recording.**
Turn the power on and insert a tape to be recorded.
- 2. **Press the VCR CONTROL button to set the Remote Control to VCR mode.**
- 3. **Select a desired channel by using the number keys.**
- 4. **Press the REC PAUSE button.**
The VCR is set to standby mode.
- 5. **Press the ▶ ^ button.**
The VCR starts recording.

To stop the recording, press the **■ ∨** button.
To pause the recording, press the REC PAUSE button. To resume the recording, press the **▶ ^** button again.

Operating a VCR other than JVC's VCR

Listening to a VCR

Press the VCR button to select a VCR as the source. Then, play the VCR connected to the system according to its instruction manual.
You can adjust VOLUME control to the desired listening level and apply the sound effects on the sound from the VCR.

Recording to a VCR

To record to a VCR, start playback of the recording source of the System and start recording on your VCR. (Refer to the VCR's instruction manual for details on the recording procedure for your VCR.)
■ You cannot record using Sound mode effects.

Using the VCR

Number keys

This illustration shows the Remote Control for CA-TD55R. The Remote Control for CA-TD5 does not have the RDS CONTROL button or include any RDS related labels.

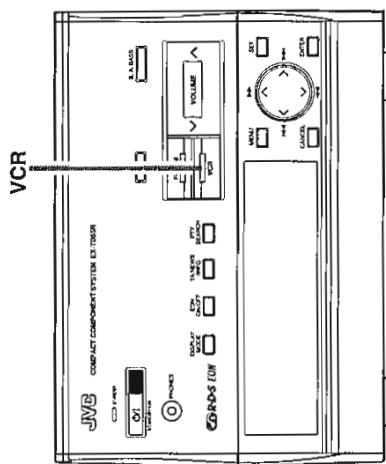
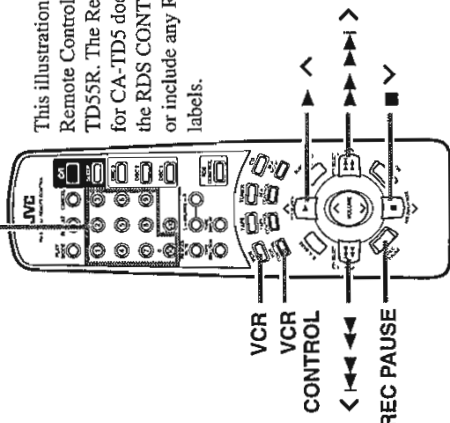

• This illustration is of CA-TD55R, CA-TD5 does not have the DISPLAY MODE, EON ON/OFF, TA/NEWS/INFO, and PTY SEARCH buttons.

VCR button and VCR CONTROL button

Press the VCR or VCR CONTROL button to switch the Remote Control to VCR control mode. You can then use the **< 1 2 3 4 5 6 7 8 9 0 >**, **■ ∨**, **▶ ^** and REC PAUSE buttons to control the VCR.

Operating a JVC VCR

The Remote Control supplied with System can control JVC VCRs.

When operating a VCR, aim the Remote Control at the remote sensor on the VCR. Set the remote code of the VCR to A.

You can use the buttons on the Remote Control to operate the following functions.

- VCR** Sets the System's source to VCR and switches the Remote Control to VCR Control mode.
- VCR CONTROL** Sets the Remote Control to VCR Control mode but does not set the source to VCR.
 - ▶ ^** Plays back a video tape.
 - ∨** Stops playback.
 - < 1 2 3 4 5 6 7 8 9 0 >** Rewinds a video tape.
 - ▶ ^** Fast-forwards a video tape.
 - Number keys** Selects the VCR channel.
 - To select a 2 digit number, press tenth digit first, then unit digit. The 10 button corresponds to 0.
 - Example : For channel 10, press 1, then 10. For channel 25, press 2, then 5.
- REC PAUSE** Sets the VCR to record standby mode.

Listening to a JVC VCR

By playing the sound from VCR through the System, you can gain control over how the music or program sounds. Once the connected equipment is playing through the System, you can apply the sound effects.

- First make sure that the optional equipment is properly connected to the System. (See page 7).

1 Set the VOLUME control to 0.

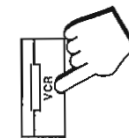

2 Press the VCR button.

The VCR button indicator lights up. When you press the VCR button on the Remote Control, sets the System's source to VCR and switches the Remote Control to VCR Control mode. When System is in Standby mode, the Unit is automatically turned on and "VCR" appears on the display.



Care And Maintenance

Compact Discs

Handle your compact discs, cassette tapes, and Cassette Deck carefully, and they will last a long time.

- Remove the CD from the case by holding it at the edges while pressing the center hole lightly.
- Do not touch the shiny surface of the CD, or bend the CD.
- Put the CD back in its case after use to prevent warping.
- Be careful not to scratch the surface of the CD when placing it back in the case.
- Avoid exposure to direct sunlight, temperature extremes, and moisture.
- A dirty CD may not play correctly. If a CD does become dirty, wipe it with a soft cloth in a straight line, from center to edge.

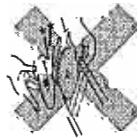

CAUTION: Do not use any solvent (for example, conventional record cleaner, spray thinner, benzine, etc.) to clean a CD.

Moisture Condensation

Moisture may condense on the lens inside the Unit in the following cases:

- After starting the heating in the room.
- In a damp room.
- If the unit is brought directly from a cold to a warm place.



Should this occur, the Unit may malfunction. In this case, leave the unit turned on for a few hours until the moisture evaporates, unplug the AC power cord, and then plug it in again.



General Notes

In general, you will have the best performance by keeping your tapes, CDs, and the mechanism clean.

- Store tapes and CDs in their cases, and keep them in cabinets or on shelves.
- Keep the Cassette Deck's tape holder and the CD trays closed when not in use.

- If you are having a problem with your System, check this list for a possible solution before calling for service.
- If you cannot solve the problem from the hints given here, or the Unit has been physically damaged, call a qualified person, such as your dealer, for service.

Troubleshooting

Symptom	Possible Cause	Action
No sound is heard.	Connections are incorrect, or loose.	Check all connections and make corrections. (See pages 4 - 7.)
Unable to record.	Cassette record protect tabs are removed.	Cover holes on back edge of cassette with tape.
Poor radio reception	<ul style="list-style-type: none"> • The antenna is disconnected. • The AM Loop Antenna is too close to the Unit. • The FM Wire Antenna is not properly extended and positioned. 	<ul style="list-style-type: none"> • Re-connect the antenna securely. • Change the position and direction of the AM Loop Antenna. • Extend FM Wire Antenna to the best reception position.
The CD skips.	The CD is dirty or scratched.	Clean or replace the CD.
Unable to operate the Remote Control.	<ul style="list-style-type: none"> • The path between the Remote Control and the sensor on the Unit is blocked. • The batteries have lost their charge. 	<ul style="list-style-type: none"> • Remove the obstruction. • Replace the batteries.
The CD tray cannot be opened.	The main AC power cord is not plugged in.	Plug in the AC power plug.
The CD does not play.	The CD is upside down.	Put the CD in with the label side up.
Operations are disabled.	<ul style="list-style-type: none"> • The built-in microprocessor has malfunctioned due to external electrical interference. • A foreign matter (headphone cable, etc.) is caught by the Main Tray cover. 	<ul style="list-style-type: none"> • Unplug the Unit then plug it back in. • Remove the foreign matter and then push the Main Tray cover by hand to close it.
The cassette door cannot be opened.	During tape playing, the power cord was unplugged.	Plug in the power cord, press the  button, and then press the  button.
"WARNING" appears in the display.	Problem arised in the Cassette Deck.	Contact your dealer.

Specifications

Amplifier/Tuner Section

Amplifier

Output Power	
SPEAKERS A (IEC 268-3/DIN) (Main)	20 watts per channel, min. RMS, both channels driven, into 6 ohms at 1 kHz with no more than 0.9% total harmonic distortion.
SPEAKERS B (Subwoofer)	30 watts per channel, min. RMS, both channels driven, into 3 ohms at 80 Hz, with no more than 10% total harmonic distortion.
Input Sensitivity/Impedance (1 kHz)	
VCR	400 mV/47 kohms
Output Impedance (1 kHz)	
VCR	10 kohms
Preset S.E.A.	3 patterns
Manual S.E.A. Control	±6 dB at 150 Hz (2 dB step) ±6 dB at 1 kHz (2 dB step) ±6 dB at 10 kHz (2 dB step)
Speaker terminals	
SPEAKERS A	6 - 16 ohms
SPEAKERS B	3 - 16 ohms

Tuner

FM Tuner	
Tuning Range	87.5 - 108.0 MHz
AM Tuner	
Tuning Range	
MW	522 - 1,629 kHz
LW	144 - 288 kHz
Dimensions	196 x 145 x 352 mm (W/H/D) (7-3/4 x 5-3/4 x 13-7/8 inches)
Mass	5.1 kg (11.3 lbs)

CD Player/Cassette Deck Section

CD Automatic Changer

CD Capacity	3 discs
Dynamic Range	96 dB
Signal-To-Noise Ratio	96 dB
Wow And Flutter	Unmeasurable

Cassette Deck

Frequency Response	
Type II (CrO ₂) :	30 - 16,000 Hz
Type I (NORMAL) :	30 - 15,000 Hz
Wow And Flutter	0.09% (WRMS)
Dimensions	196 x 145 x 348 mm (W/H/D) (7-3/4 x 5-3/4 x 13-3/4 inches)
Mass	4.2 kg (9.3 lbs)

Accessories

AM (MW/LW) Loop Antenna	(1)
Remote Control	(1)
Batteries R6P (SUM-3)/AA (15F)	(2)
FM Wire Antenna	(1)
External Wire	(1)

Power Specifications

Power Requirements	AC 230 V \sim , 50 Hz
Power Consumption	86 watts 12 watts (in standby mode)

Design and specifications are subject to change without notice.

Description of ICs

■ MN173222JAAY (IC801) Tuner & Display controller

1. Terminal Layout

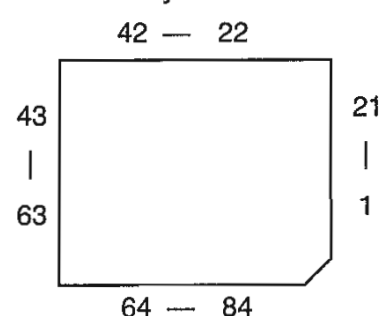

2. Key Matrix

	KEY OUT0	KEY OUT1	KEY OUT2	KEY OUT3	KEY OUT5	KEY OUT6
KEY IN0	POWER	VOLUME V	◀	MENU	BAND0	RDS
KEY IN1	SEA	VCR	◀▶	CANCEL	BAND1	
KEY IN2	3DPHONIC	FM/AM	▶	ENTER		
KEY IN3	BASS	VOLUME ▲	▶▶	SET		

3. Description

Pin No.	Symbol	I/O	Function and Operation	Pin No.	Symbol	I/O	Function and Operation
1	S10	O	FL segment control signal	43	CMDT2C	O	Data signal for IC751
2	S9	O	FL segment control signal	44	CMRDYA	I	Ready signal
3	S8	O	FL segment control signal	45	CMCLKA	I	Clock signal
4	S7	O	FL segment control signal	46	CMDT1A	I	Data signal from IC401
5	S6	O	FL segment control signal	47	CMDT2A	O	Data signal for IC401
6	S5	O	FL segment control signal	48	INH	O	Inhibit signal output
7	GND	-	Connected to GND	49	RSDST	O	Reset signal for IC191
8	GND	-	Connected to GND	50	/TUNED	O	TUNED indication control
9	GND	-	Connected to GND	51	STEREO	O	STEREO indication control
10	13G	O	FL grid control signal	52	TMUTE	O	Tuner mute signal output
11	12G	O	FL grid control signal	53	DCSOUT	O	DCS control signal output
12	11G	O	FL grid control signal	54	DCSIN	I	DCS control signal input
13	10G	O	FL grid control signal	55		-	Connected to GND
14	9G	O	FL grid control signal	56	KI0	I	Key matrix input
15	8G	O	FL grid control signal	57	KI1	I	Key matrix input
16	7G/KO6	O	FL grid control signal/Key matrix out	58	KI2	I	Key matrix input
17	6G/KO5	O	FL grid control signal/Key matrix out	59	KI3	I	Key matrix input
18	5G/KO4	O	FL grid control signal/Key matrix out	60	IFDATA	I	Data from PLL synthesizer
19	4G/KO3	O	FL grid control signal/Key matrix out	61	TCE	O	Chip select terminal input
20	3G/KO2	O	FL grid control signal/Key matrix out	62	TCK	O	Clock for PLL synthesizer
21	2G/KO1	O	FL grid control signal/Key matrix out	63	TDATA	O	Data for PLL synthesizer
22	1G/KO0	O	FL grid control signal/Key matrix out	64	RDSCLK	I	Clock input from IC191
23	-Vpp	-	Power Supply (-Vpp)	65	RSDATA	I	Data signal from IC191
24	S4	O	FL segment control signal	66	RDSRST	O	Reset signal for IC191
25	S3	O	FL segment control signal	67	FOUT	O	Clock frequency
26	S2	O	FL segment control signal	68	/RESET	I	Reset signal input
27	S1	O	FL segment control signal	69	X1	-	Connected to GND
28		-	Connected to GND	70	X2	-	Non connection
29		-	Connected to GND	71	VSS	-	Connected to GND
30		-	Connected to GND	72	OSC2	I/O	Clock oscillation terminal
31		-	Connected to GND	73	OSC1	I/O	Clock oscillation terminal
32		-	Connected to GND	74	VDD	-	Power supply
33		-	Connected to GND	75		-	Connected to GND
34		-	Connected to GND	76	S19	O	FL segment control signal
35		-	Connected to GND	77	S18	O	FL segment control signal
36		-	Connected to GND	78	S17	O	FL segment control signal
37		-	Connected to GND	79	S16	O	FL segment control signal
38		-	Connected to GND	80	S15	O	FL segment control signal
39		-	Connected to GND	81	S14	O	FL segment control signal
40	CMRDYC	I	Ready signal	82	S13	O	FL segment control signal
41	CMCLKC	I	Clock signal	83	S12	O	FL segment control signal
42	CMDTIC	I	Data signal from IC751	84	S11	O	FL segment control signal

RX-TD5/RX-TD55R

■ HD404019RC87FS (IC401) Amp & DSP controller

1. Terminal Layout

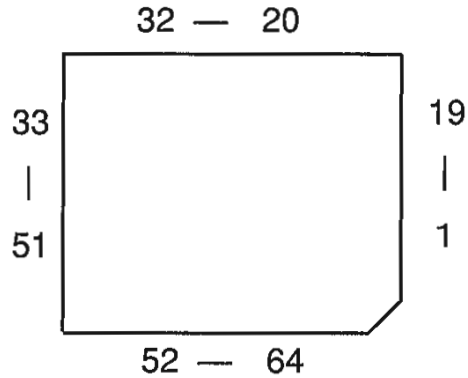

2. Description

Pin No.	Symbol	I/O	Description	Pin No.	Symbol	I/O	Description
1		-	Non connection	33	DSCK	O	Clock signal for DSP micon(IC061)
2		-	Non connection	34	DDATA	O	Data signal for DSP micon(IC061)
3	DCSOUT	O	DCS signal output	35	HRS	O	Data frame sync signal for DSP micon(IC061)
4	DCSIN	I	DCS signal input	36	/CS	O	Chip select signal for DSP micon(IC061)
5		-	Connected to GND	37	/RST	O	Reset signal for DSP micon(IC061)
6		-	Connected to GND	38	/MUTE	O	Mute control signal for DSP micon(IC061)
7		-	Connected to GND	39	/EMPTY	I	EMPTY flug input from DSP micon(IC061)
8		-	Connected to GND	40		-	Connected to GND
9		-	Connected to GND	41		-	Connected to GND
10		-	Connected to GND	42		-	Connected to GND
11		-	Connected to GND	43	RESET	I	Reset signal input
12		-	Connected to GND	44	/TEST	-	+5.6V pull up
13		-	Connected to GND	45	OSC	I/O	Osillation terminal
14	SCK1	O	Clock signal output for IC402	46	OSC	I/O	Osillation terminal
15	SDA1	O	Data signal output for IC402	47	GND	-	Connected to GND
16	/RMIN	I	Remoto control signal input	48	SURRON	O	Surrond amp control signal
17		-	Connected to GND	49	POWER	O	Power ON/OFF control
18			Non connection	50	SMUTE	O	Source mute signal output
19			Non connection	51		-	Connected to GND
20	/PRT	I	Protector signal input	52		-	Connected to GND
21	/INH	-	Inhibit signal input	53	VSENCE	-	Signal Control
22		-	Non connection	54	SPK	O	Speaker relay ON/OFF control
23	BENA	O		55		-	Connected to GND
24	BDATA	O	Data signal output for IC404	56		-	Connected to GND
25	BCLK	O	Clock signal output for IC404	57		-	Connected to GND
26	Vcc	-	+5.6V	58		-	Connected to GND
27	CMCLKA	O	Clock signal	59	TUNERI	O	TUNER indication signal control
28	CMDT2A	I	Data signal from IC801	60	VCRI	O	VCR indication signal control
29	CMDT1A	O	Data signal for IC801	61	BASSI	O	BASS indication signal control
30	CMRDYA	O	Ready signal	62	3DI	O	3Dphonic indication signal control
31	VRMUTE	O	Main VR mute signal output	63	STDBY	O	STDBY indication signal control
32	STB	-	Strobe signal for IC061	64		-	No connection

■ LA1837(IC102): FM AM IF AMP&detector, FM MPX Decoder

1. Block Diagram

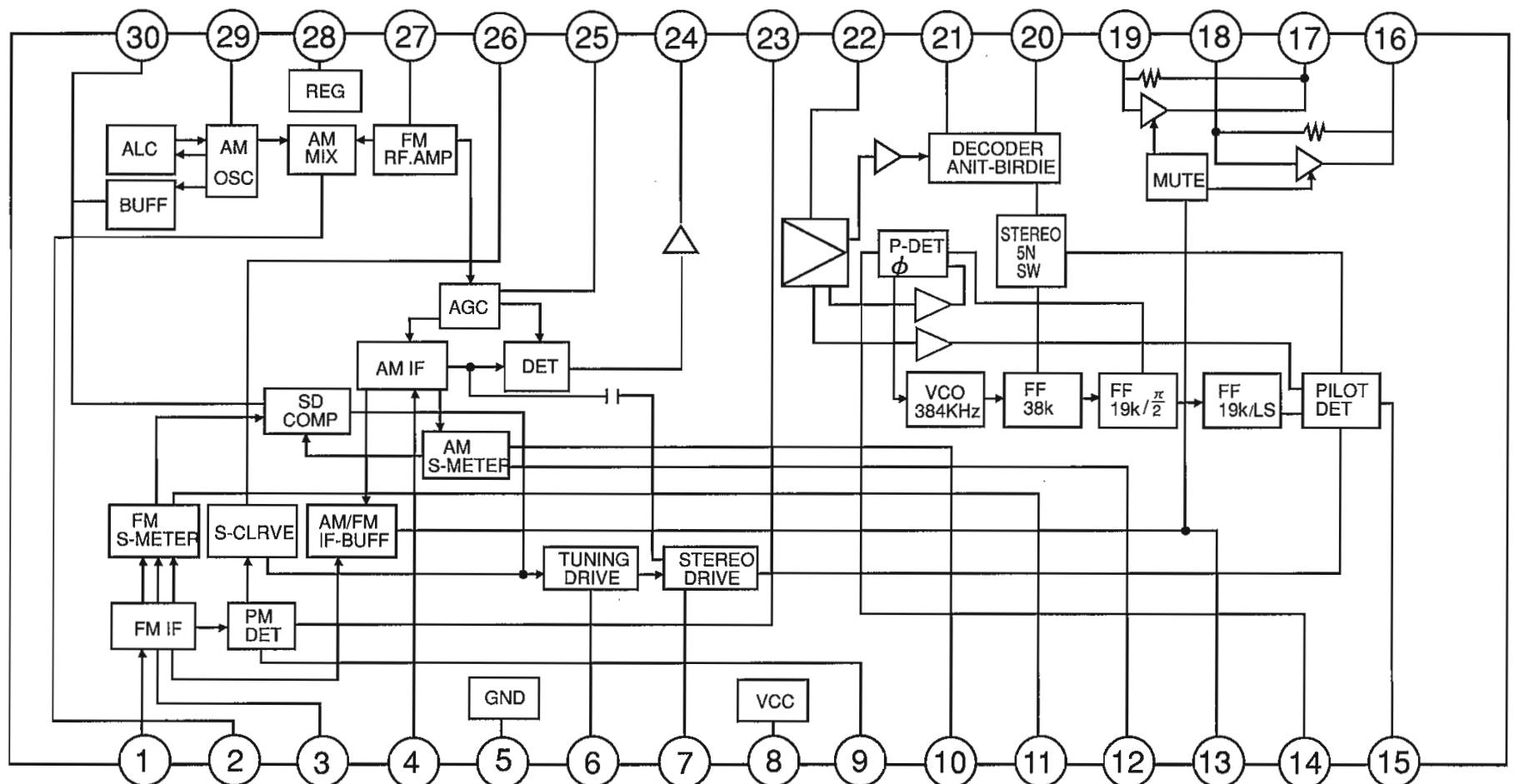

3. Pin Function

Pin No.	Symbol	I/O	Function	Pin No.	Symbol	I/O	Function
1	FM IN	I	This is an input terminal of FM IF signal.	16	L OUT	O	Left channel signal output.
2	AM MIX	O	This is an out put terminal for AM mixer.	17	R OUT	O	Right channel signal output.
3	FM IF	I	Bypass of FM IF	18	L IN	I	Input terminal of the Left channel post AMP.
4	AM IF	I	Input of AM IF Signal.	19	R IN	I	Input terminal of the Right channel post AMP.
5	GND	-	This is the device ground terminal.	20	RO	O	Mpx Right channel signal output.
6	TUNED	O	When the set is tuning,this terminal becomes "L".	21	LO	O	Mpx Left channel signal output.
7	STEREO	O	Stereo indicator output. Stereo "L", Mono: "H"	22	IF IN	I	Mpx input terminal
8	VCC	-	This is the power supply terminal.	23	FM OUT	O	FM detection output.
9	FM DET	-	FM detect transformer.	24	AM DET	O	AM detection output.
10	AM SD	-	This is a terminal of AM ceramic filter.	25	AM AGC	I	This is an AGC voltage input terminal for AM
11	FM VSM	O	Adjust FM SD sensitivity.	26	AFC	-	This is an output terminal of voltage for FM-AFC.
12	AM VSM	O	Adjust AM SD sensitivity.	27	AM RF	I	AM RF signal input.
13	MUTE	I/O	When the signal of IF REQ of IC121(LC72131) appear, the signal of FM/AM IF output. //Muting control input.	28	REG	O	Register value between pin 26 and pin28 desides the frequency width of the input signal.
14	FM/AM	I	Change over the FM/AM input. "H" :FM, "L" : AM	29	AM OSC	-	This is a terminal of AM Local oscillation circuit.
15	MONO/ST	O	Stereo : "H", Mono: "L"	30	OSC BUFFER	O	AM Local oscillation Signal output.

RX-TD5/RX-TD55R

LC72131(IC121):PLL Synthesizer

1. Terminal Layout

XIN	1	22	XOUT
	2	21	VSS
PLLCE	3	20	LPF OUT
PLLDA	4	19	LPF IN
PLLCK	5	18	PD
IFDATA	6	17	VDD
FM	7	16	FM OSC
MW	8	15	AM OSC
LW	9	14	
AUTO/MONO	10	13	IF REQ
POWER	11	12	FM/AM IF

2. Block Diagram

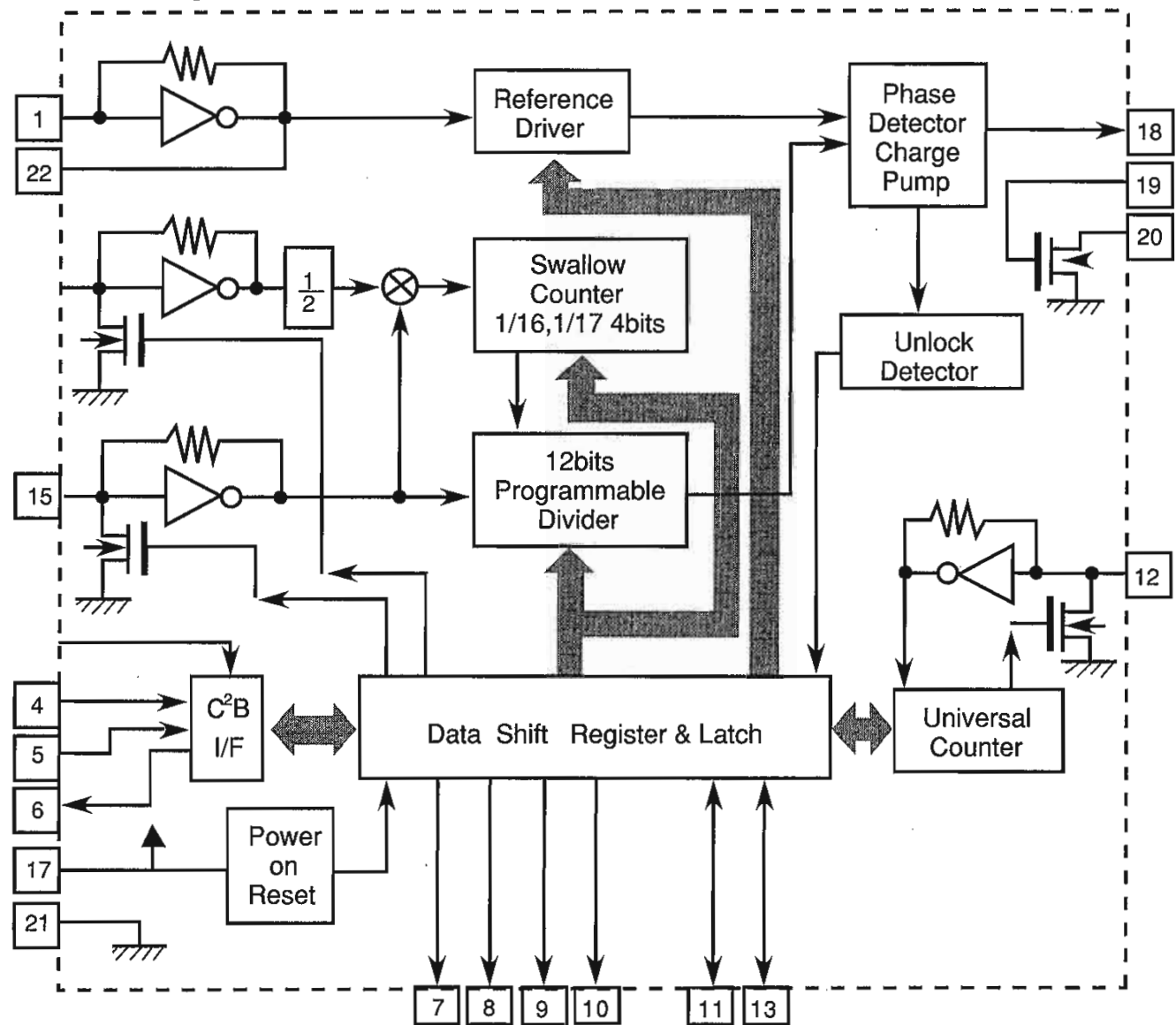

3. Pin Functions

Pin No.	Symbol	I/O	Functions	Pin No.	Symbol	I/O	Functions
1	Xin	I	Crystal oscillator (7.2MHz).	12	FM/AM IF	I	Universal counter input
2		--	Not use	13	IF REQ	O	Output the "IF-signal request" to IC102
3	PLLCE	I	Fix the chip enable to "H" when inputting (DI) and outputting (DO) the serial data	14		I	Not use
4	PLLDA	I	Receive the control data from the controller (IC801).	15	AMOSC		Input the local oscillator signal of AM.
5	PLLCK	I	This clock is used to synchronize data when transmitting the data of DI and DO.	16	FM OSC	I	Input the local oscillator signal of FM.
6	IFDATA	O	Transmit the data from LC72131 to the controller which is synchronized with CK.	17	VDD	O	This is a terminal of power supply.
7	FM	O	It is "L" on FM mode.	18	PD	O	PLL charge pump output : When the local oscillator signal frequency is higher than the reference frequency high level signals will output. When it is lower than the reference frequency, low level signals will output. When it is same as reference frequency signals, it will be floating.
8	MW	O	It is "L" on MW mode.	19	LPF IN	I	Transistor used for the PLL active low-pass filter
9	LW	O	It is "L" on LW mode.	20	LPF OUT	O	Transistor used for the PLL active low-pass filter
10	AUTO/MONO	O	It is "L" on monaural, "L" on auto	21	VSS	--	Connected to GND
11	POWER	O	Regulator control signal P ON "H", STANDBY "L"	22	X out	O	Crystal oscillator(7.2MHz).

■ SAA6579 (IC192) : Radio data system demodulator

1. Terminal Layout

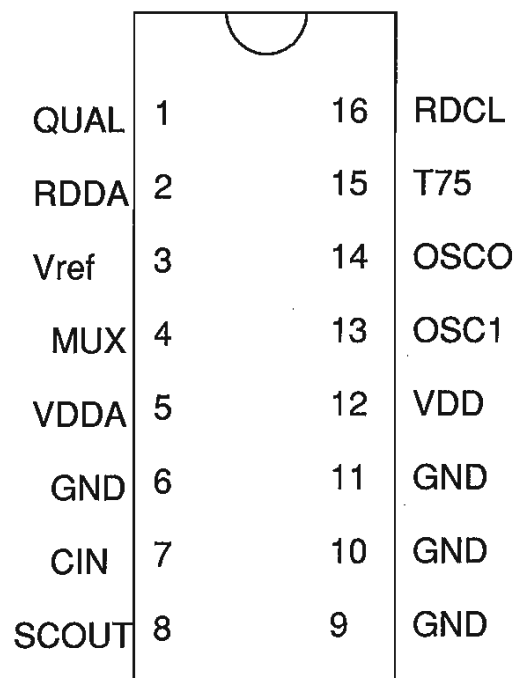

2. Pin Function

Pin No	Symbol	I/O	Function
1	QUAL	--	Non connection
2	RDDA	O	RDS data output
3	Vref	O	Reference voltage output
4	MUX	I	Multiplex signal input
5	VDDA	--	+5Vsupply voltage for analog
6	GND	--	Ground for analog part(0V)
7	CIN	I	Subcarrier outputof reconstruction filter
8	SCOUT	O	Ground for digital part(0V)
9	GND	--	Ground for digital part(0V)
10	GND	--	Ground for digital part(0V)
11	GND	--	Ground for digital part(0V)
12	VDD	--	+5Vsupply voltage fordigital part
13	OSC1	I	Oscilator input
14	OSCO	O	Oscilator OUTput
15	T57	--	Non connection
16	RDCL	O	RDS clock output

3. Block Diagram

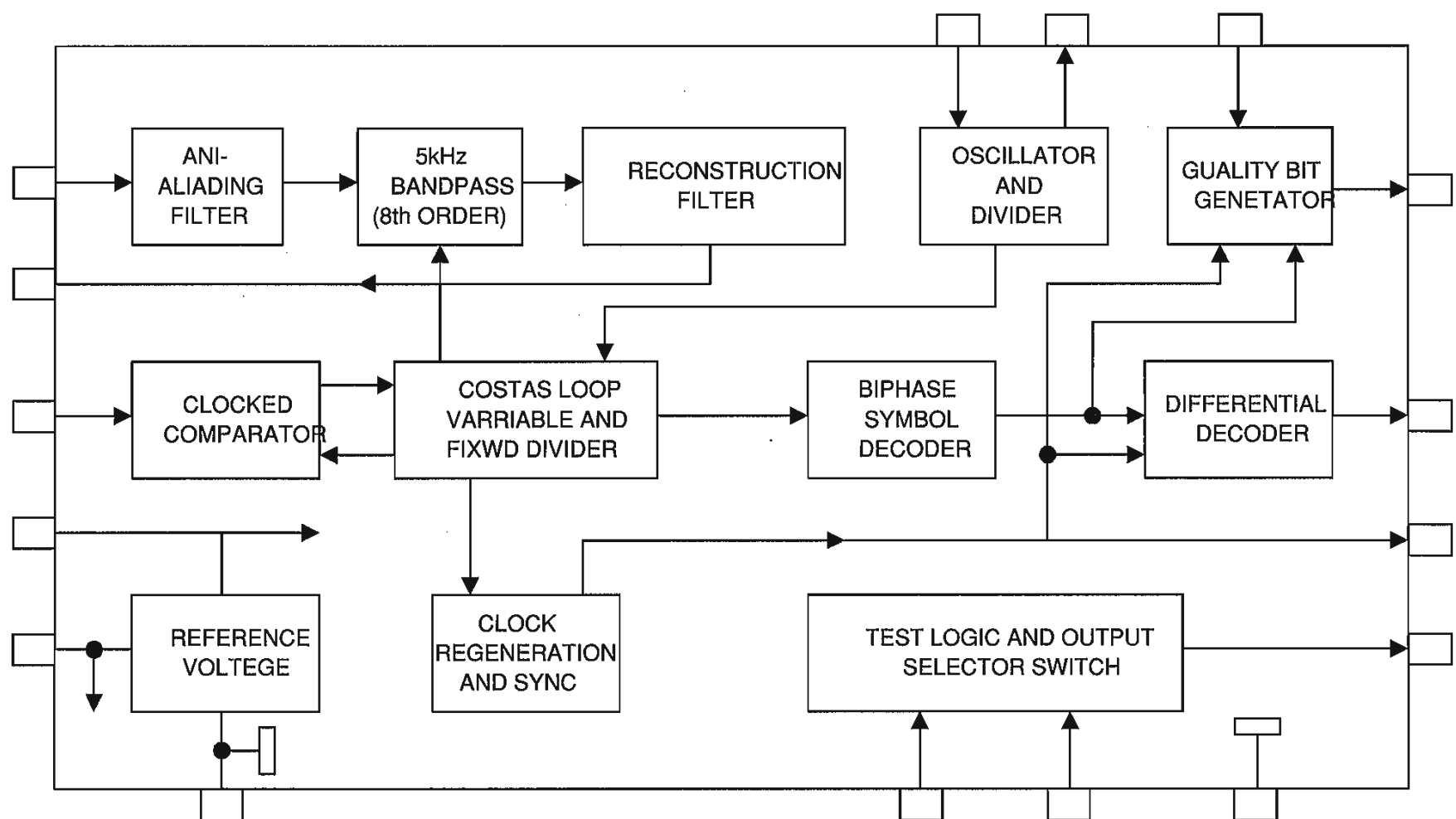

RX-TD5/RX-TD55R

■ LC7073M (IC191): Radio Data System

1. Terminal Layout

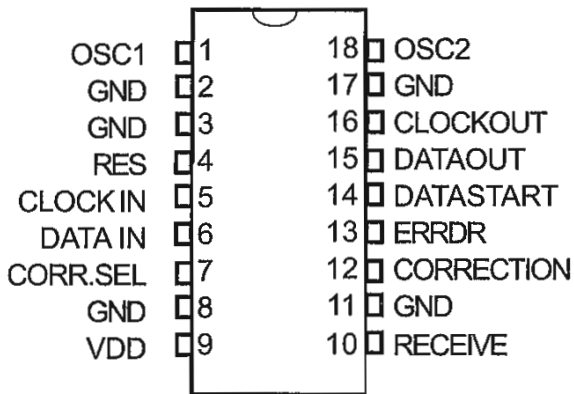

2. Block Diagram

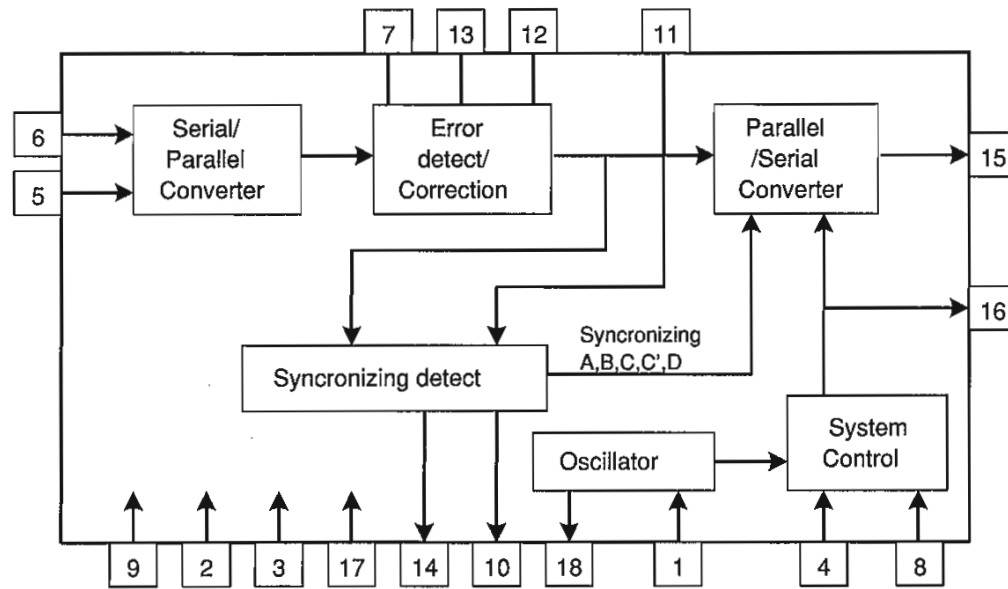

3. Pin Function

Pin No.	Symbol	I/O	Function	Pin No.	Symbol	I/O	Function
1	OSC1	I	Oscillation	10	RECEIVE	--	Non connection
2	GND	--	GND	11	GND	--	GND
3	GND	--	GND	12	CORRECTION	--	Non connection
4	RES	I	Reset input	13	ERRDR	--	Non connection
5	CLOCK IN	I	RDS clock input	14	DATA START	O	Data start signal for block data to output serial data
6	DATA IN	I	RDS data input	15	DATA OUT	O	Serial data output
7	CORR.SEL	I	Non connection	16	CLOCK OUT	O	Data output of serial data output
8	GND	I	GND	17	GND	--	GND
9	VDD	--	Power supply	18	OSC2	O	Oscillation terminal

■ LA2650 (IC404)

1. Terminal Layout/Block diagram

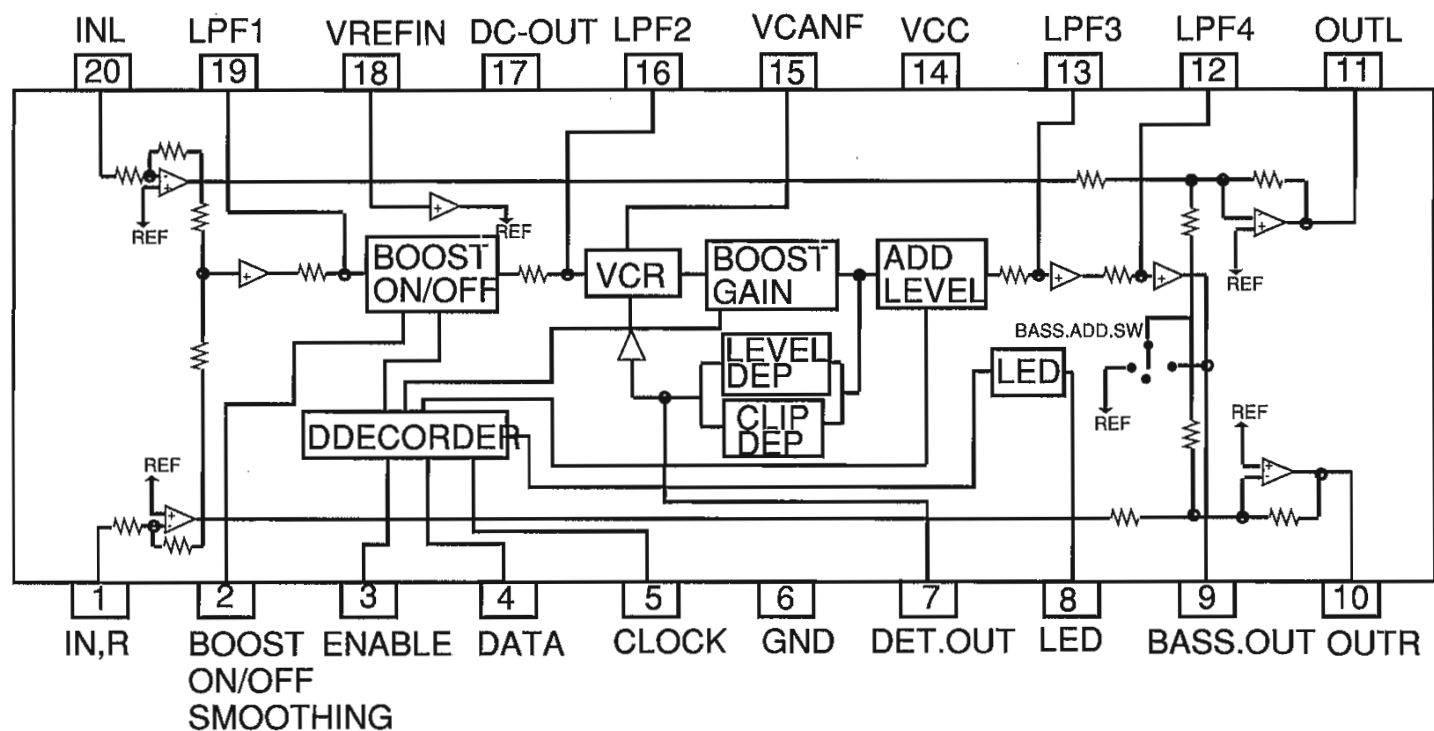

■ IR3R42 (IC104) POLAR STEREO DETECTOR

1. Terminal Layout/Block diagram

VDD	1	20	SUMIN
IN	2	19	SUBOUT
PAIT	3	18	MONITOR
RHC	4	17	VCO
LHC	5	16	LPF1A
ROUT	6	15	LPF1B
LOUT	7	14	DETIN
S.T.	8	13	LPF2A
VCOSTOP	9	12	LPF2B
LAMP	10	11	GND

2. Block diagram

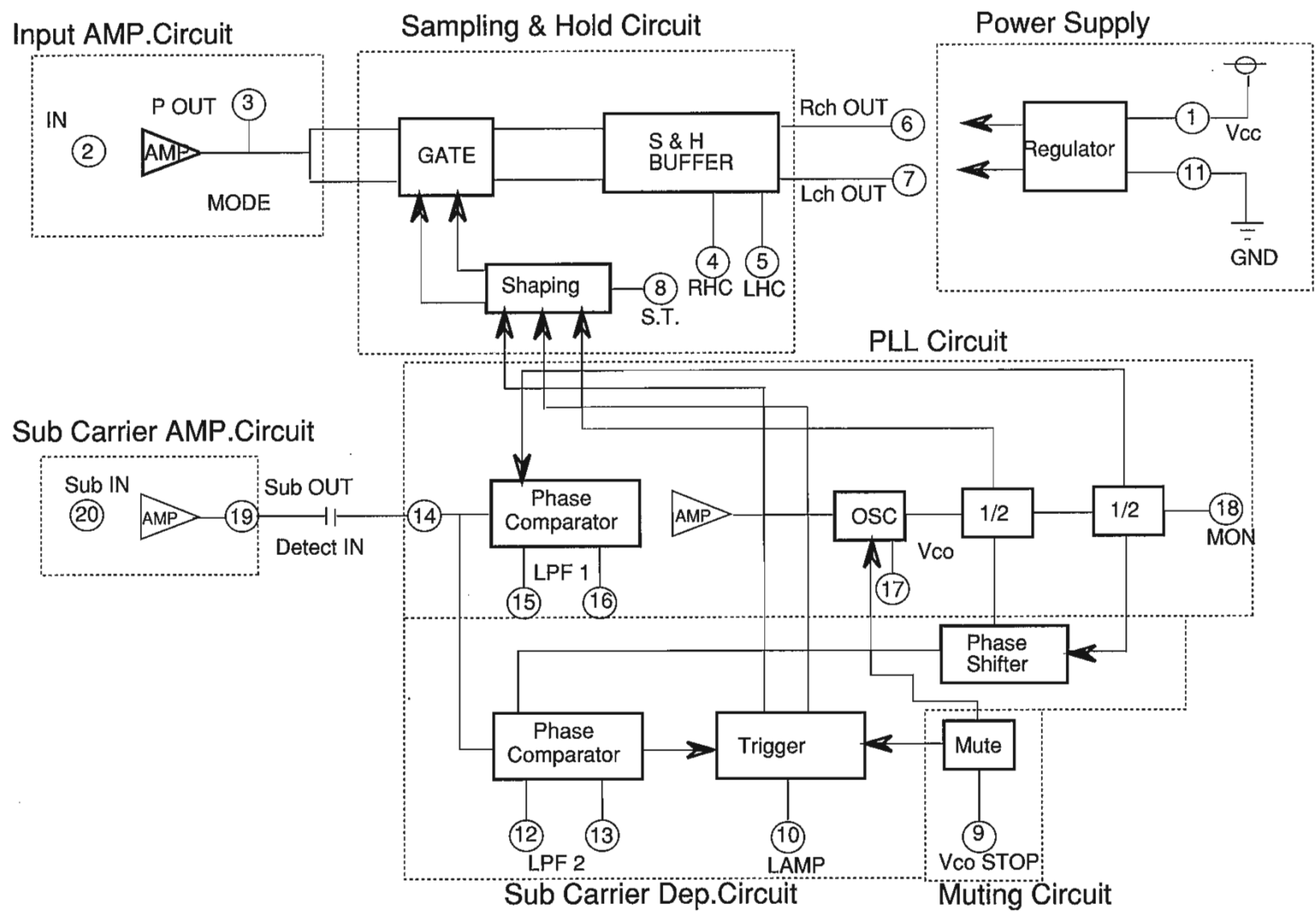

RX-TD5/RX-TD55R

Internal Connections the FL Display

1. Terminal Layout

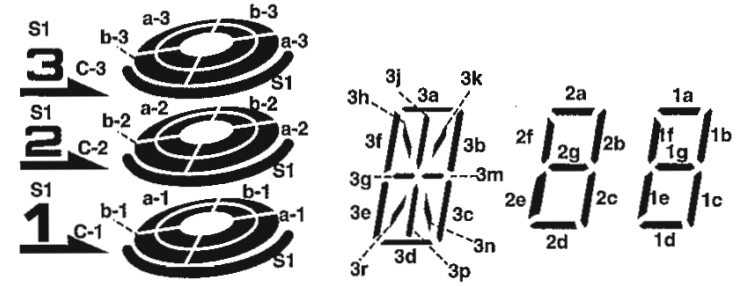
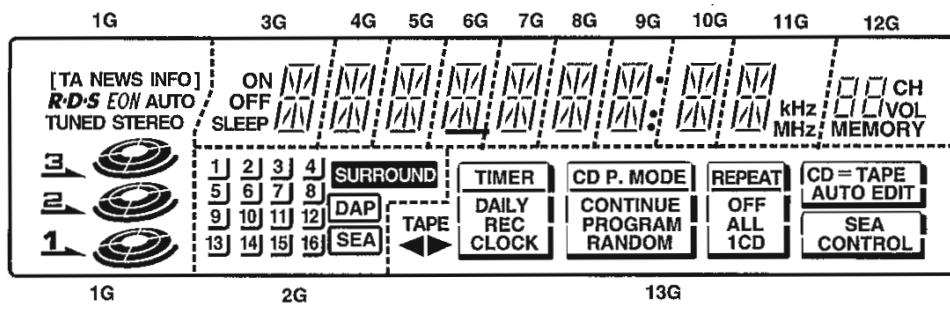

2. Anode Designation

	1G	2G	3G	4-8G	9G	10G	11G	12G	13G
P1	c-1	16	3a	3a	3a	3a	3a		
P2	b-1	15	3b	3b	3b	3b	3b	2a	▶
P3	a-1	14	3j	3j	3j	3j	3j	2b	◀
P4	c-2	13	3k	3k	3k	3k	3k	2f	TAPE
P5	b-2	12	3h	3h	3h	3h	3h	2g	CLOCK
P6	a-2	11	3f	3f	3f	3f	3f	2c	REC
P7	S1	10	3g	3g	3g	3g	3g	2e	DAILY
P8	c-3	9	3m	3m	3m	3m	3m	2d	TIMER
P9	b-3	8	3c	3c	3c	3c	3c		CONTINUE
P10	a-3	7	3n	3n	3n	3n	3n	1a	PROGRAM
P11	TUNED	6	3r	3r	3r	3r	3r	1b	RANDOM
P12	STEREO	5	3p	3p	3p	3p	3p	1f	CD P. MODE
P13	R.D.S	4	3e	3e	3e	3e	3e	1g	OFF
P14	EON	3	3d	3d	3d	3d	3d	1c	ALL
P15	AUTO	2						1e	CD
P16	INFO	1						1d	1
P17	NEWS	SEA	ON		4a		kHz	CH	REPEAT
P18	TA	DAP	OFF		4b		MHz	VOL	CD = TAPE AUTO EDIT
P19	[]	SURROUND	SLEEP		4c			MEMORY	SEA CONTROL

3. Terminal Connection

Terminal No.	1	2	3	4	5	6	7	8	9	10	11										
Electrode	F	F	F	NP	1G	2G	3G	4G	5G	6G	7G										
Terminal No.	12	13	14	15	16	17	18	19	20	21	22	23	24	25	26	27	28	29	30	31	
Electrode	8G	9G	10G	11G	12G	13G	NP	P 1	P 2	P 3	P 4	P 5	P 6	P 7	P 8	P 9	P 10	P 11	P 12	P 13	
Terminal No.											32	33	34	35	36	37	38	39	40	41	42
Electrode											P 14	P 15	P 16	P 17	P 18	P 19	NP	NP	F	F	F

Main parts Layout

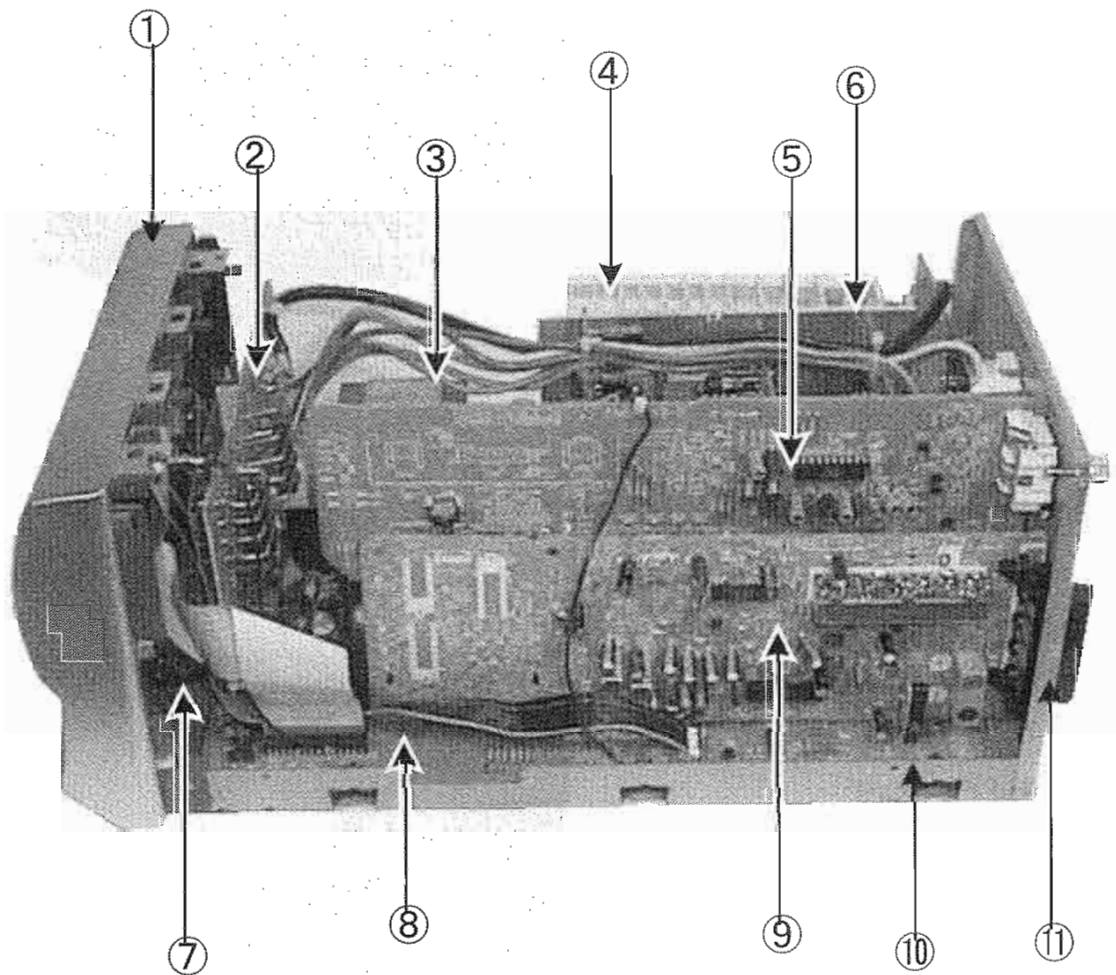

- ① Front Panel
- ② Power Supply PCB
- ③ Power Transformer
- ④ Heat sink
- ⑤ Source Select PCB
- ⑥ Power amp PCB ass'y
- ⑦ Front panel PCB
- ⑧ Connector & Speaker out PCB
- ⑨ Tuner PCB
- ⑩ Bottom Base
- ⑪ Rear panel

RX-TD5 Inside View

Disassembly Procedures

(1) Removing the top cover

1. Remove 2 screws(A) fastening both sides of top cover, and 4 screws(B) fastening the rear side.
2. Remove the top cover.

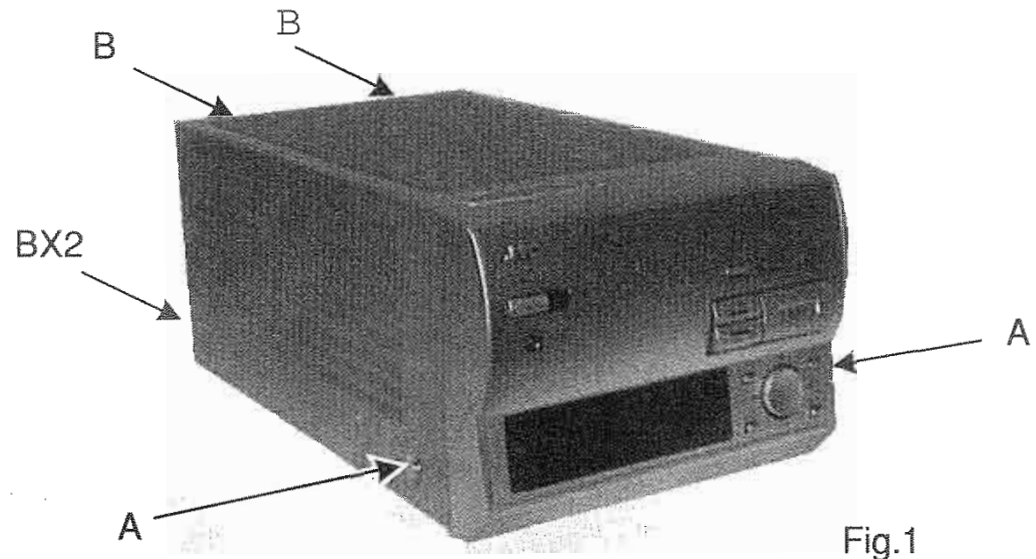

Fig.1

(2) Removing the Rear panel

1. Remove 7 screws(C) fastening rear panel (Fig.2).
2. Remove 2 screws(C) fastening Voltage selector. (Universal type only)
3. Remove the Rear panel from the Hook of Bottom base.

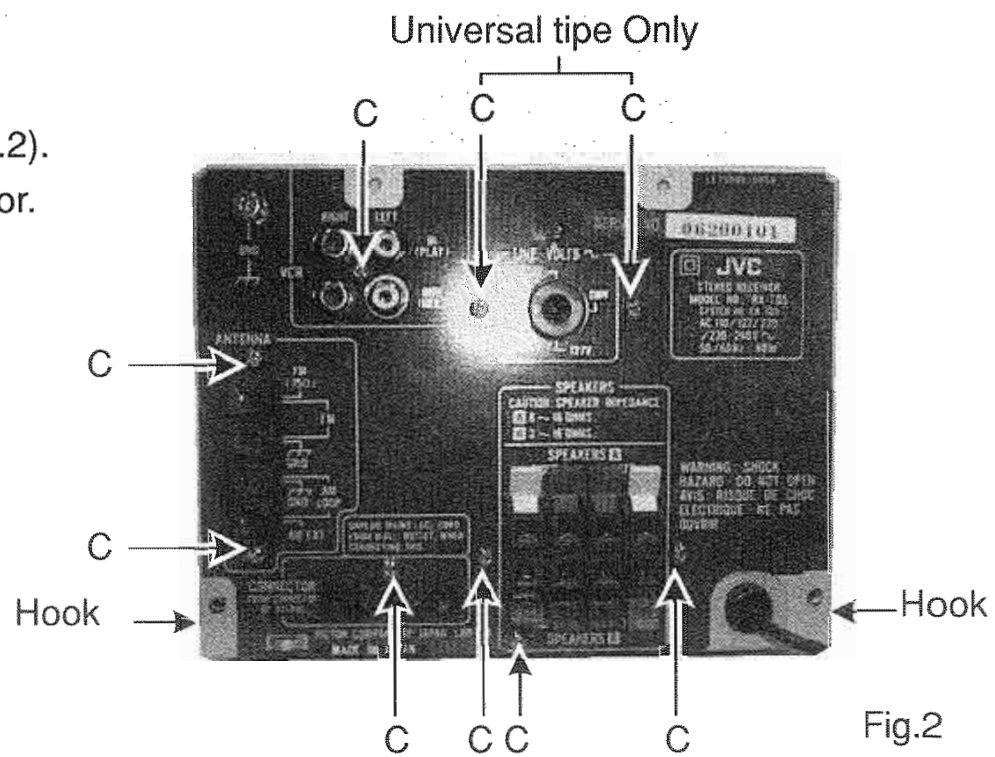

Fig.2

(3) Removing the Tuner PCB and Source Select PCB

1. Remove the Rear panel.
2. Remove the screw H' (Fig.3). (Universal type only)
3. Disconnect the Tuner PCB from the CN101.
4. Disconnect the Source Select PCB from the CN411 and CN412.

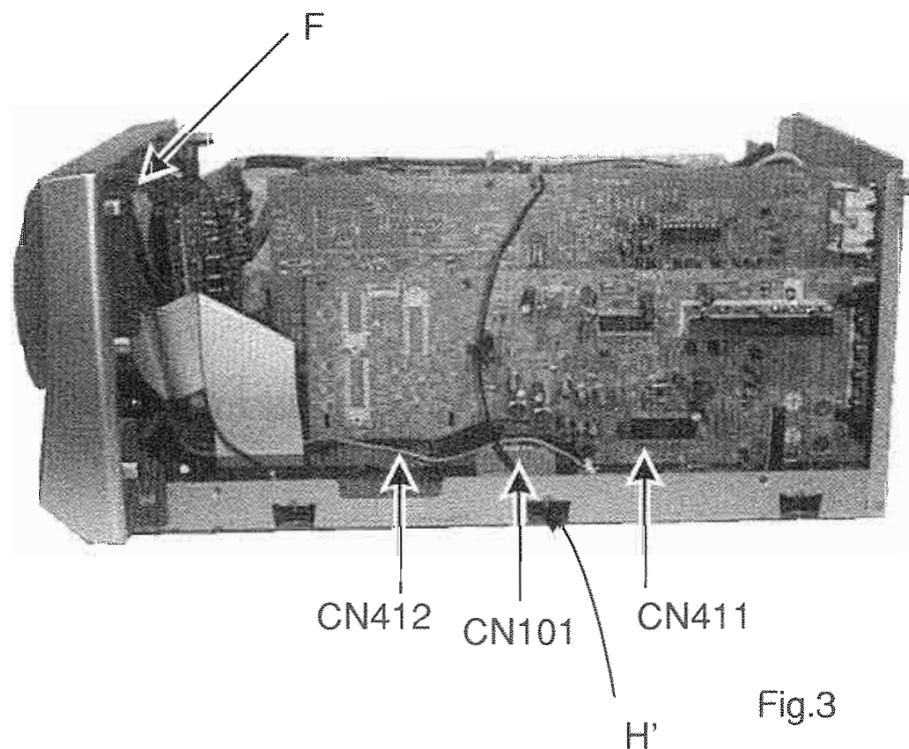
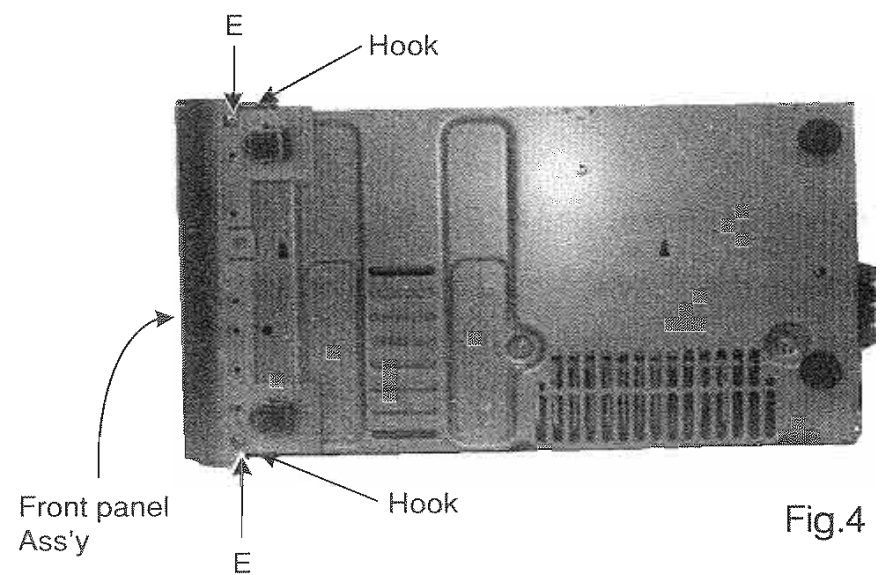

Fig.3

(4) Removing the Front panel Ass'y

- 1.Remove 2 screws(E)fastening Front panel of the Bottom side (Fig.4).
- 2.Remove screws(F)fastening Earth wire of the up side(Fig3).
- 3.Disconnect the Flat Wires from CN891,CN811, CN202.
- 4.Release the 2 Hooks holding the Front panel.
- 5.Remove it.



(5) Removing the Power amp PCB & Heat sink Ass'y

- 1.Remove 4 screws(G)fasteing the Bracket of Heat sink (Fig.5).
- 2.Disconnect the Power amp PCB with Heat sink ass'y from CN261,CN311,CN312.

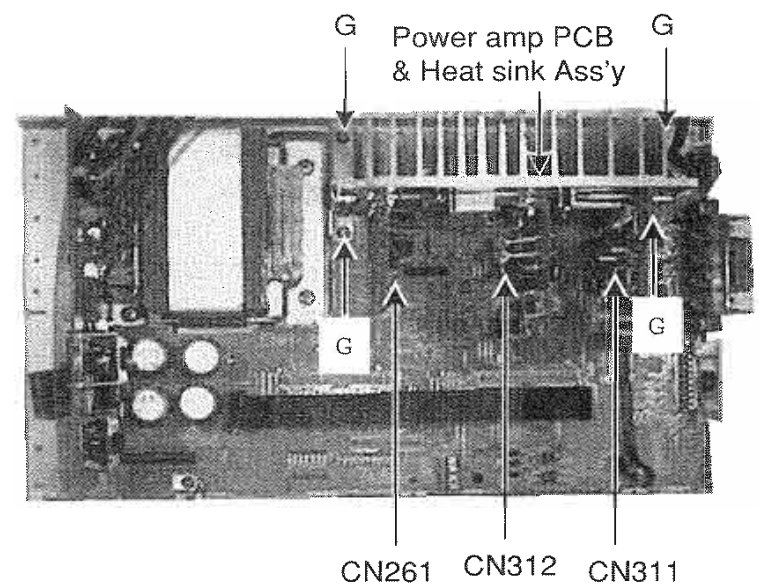

Fig.5

(6) Removing the Connector & Speaker out PCB

- 1.Remove the Rear panel and Power amp PCB and Heat sink ass'y.
- 2.Disconnect the Flat Wires CN891,CN811, CN202.
- 3.Remove 2 screws(H)fastening Connector & Speaker out PCB and Remove it.
Exsept Universal type 2screws"H"+"H"
Universal type 2screws"H"

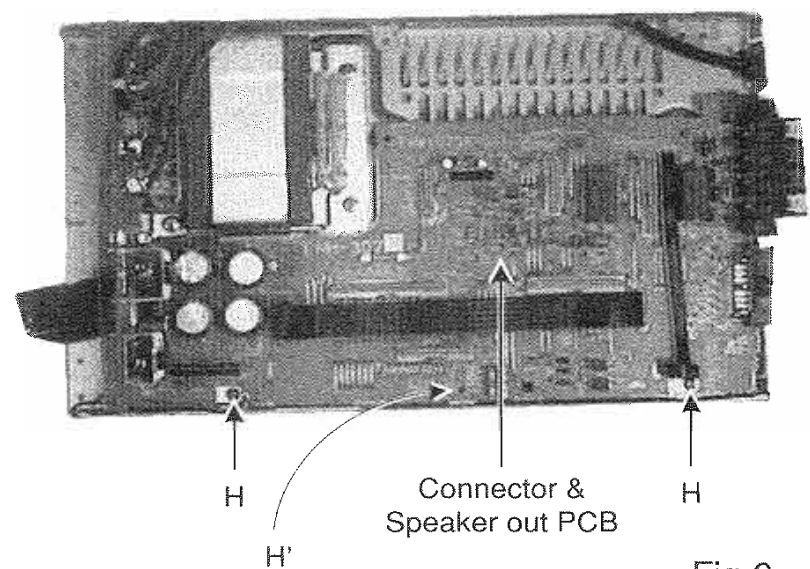

Fig.6

(7) Removing the Front PCB

- 1.Remove the Front panel Ass'y.
- 2.Remove 13screws(I)fastening Front PCB
- 3.Remove the Front PCB.

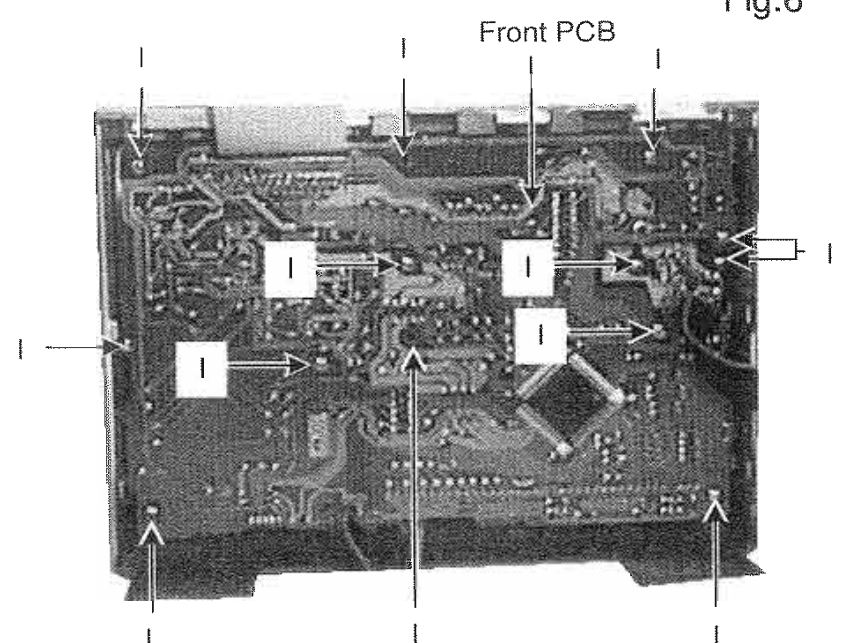

Fig.7

RX-TD5/RX-TD55R

(8) Removing the Power amp PCB ass'y

- 1.Remove the Power amp & Heat sink Ass'y .
- 2.Remove the 5 screws (J).
- 3.Remove the Power amp PCB ass'y.

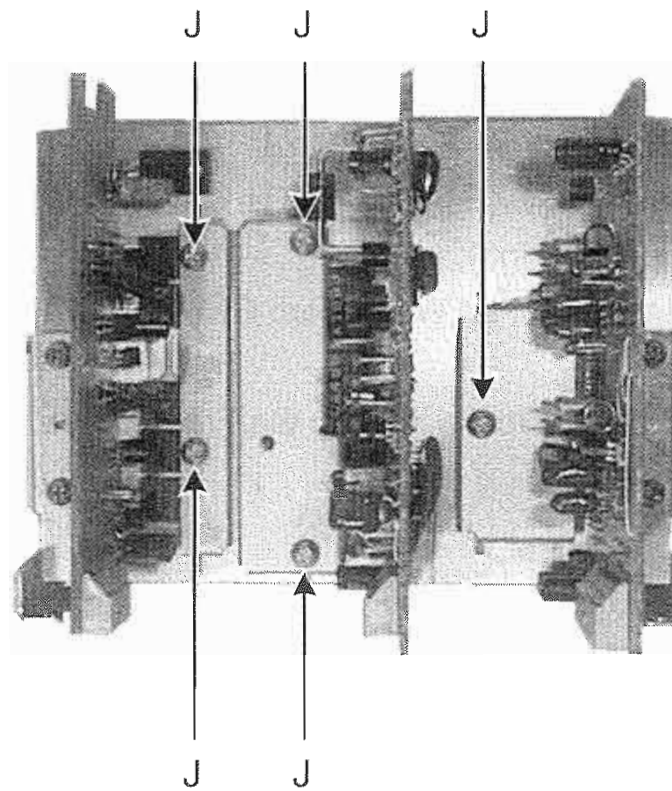

Fig.8

(9) Removing the Power IC

- 1.Remove the Power amp PCB Ass'y.
- 2.Unsolder the Power IC terminal.
- 3.Remove the Power IC.

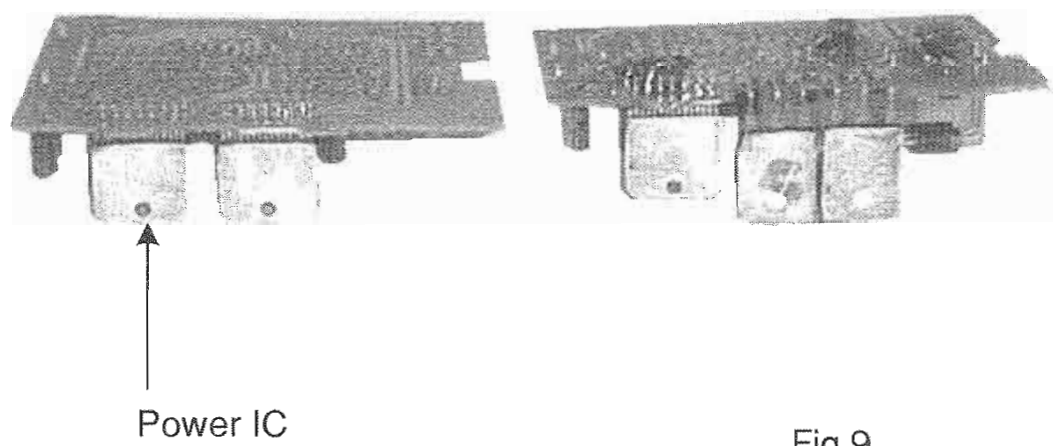
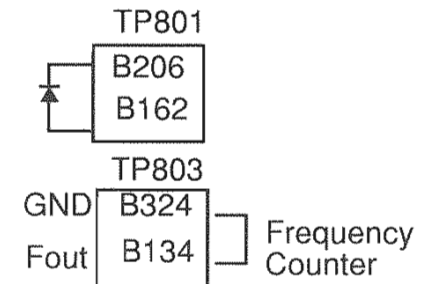
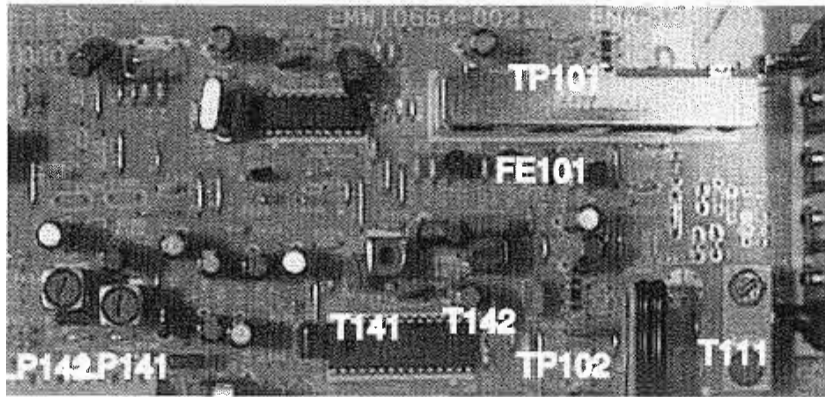

Fig.9

ADJUSTMENT PROCEDURES



Clock Adjustment

1. After connecting B206 and B162(TP801) with some wire as shown in the figure below, connect the AC power cord into an AC outlet.
2. Confirm that the display is off and remove the wire.
3. Connect a frequency counter to TP803 B324 and B134.
4. Check the frequency $50000 \pm 0.29\text{Hz}$.

(1) Tuning voltage

Confirm the voltages at TP101 is within the standard values shown in the table below.

Area	Range				
	LW(kHz)	MW(kHz)	FM(kHz)	FM TU.VOL	
				87.5MHz	108.0MHz
	144~288	522~1629	87.5~108.0	1.6 ± 1.0	8.0 ± 2.0
the U.S.A.Canada	-	530~1710	87.5~108.0	1.6 ± 1.0	8.0 ± 2.0
Universal type(AM Channel space 9kHz)	-	531~1602	87.5~108.0	1.6 ± 1.0	8.0 ± 2.0
Universal type(AM Channel space 10kHz)	-	530~1600	87.5~108.0	1.6 ± 1.0	8.0 ± 2.0
Easern Europe	144~288	522~1629	65.0~74.0 87.5~108.0	65.0MHz >1.3	108.0MHz <11

Area	Frequency(MW)							Frequency(LW)	
	522kHz	530kHz	531kHz	1600kHz	1602kHz	1629kHz	1710kHz	144kHz	288kHz
A,the U.K.,Europe	>0.7	-	-	-	-	<8.3	-	$0.5 < 1.0$	$5.0 < 7.5$
the U.S.A.Canada	-	>0.8	-	-	-	-	<8.8	-	-
Universal(Channel space 9kHz)	-	-	>0.8	-	<7.9	-	-	-	-
Universal(Channel space 10kHz)	-	>0.8	-	<7.9	-	-	-	-	-

Block Diagram

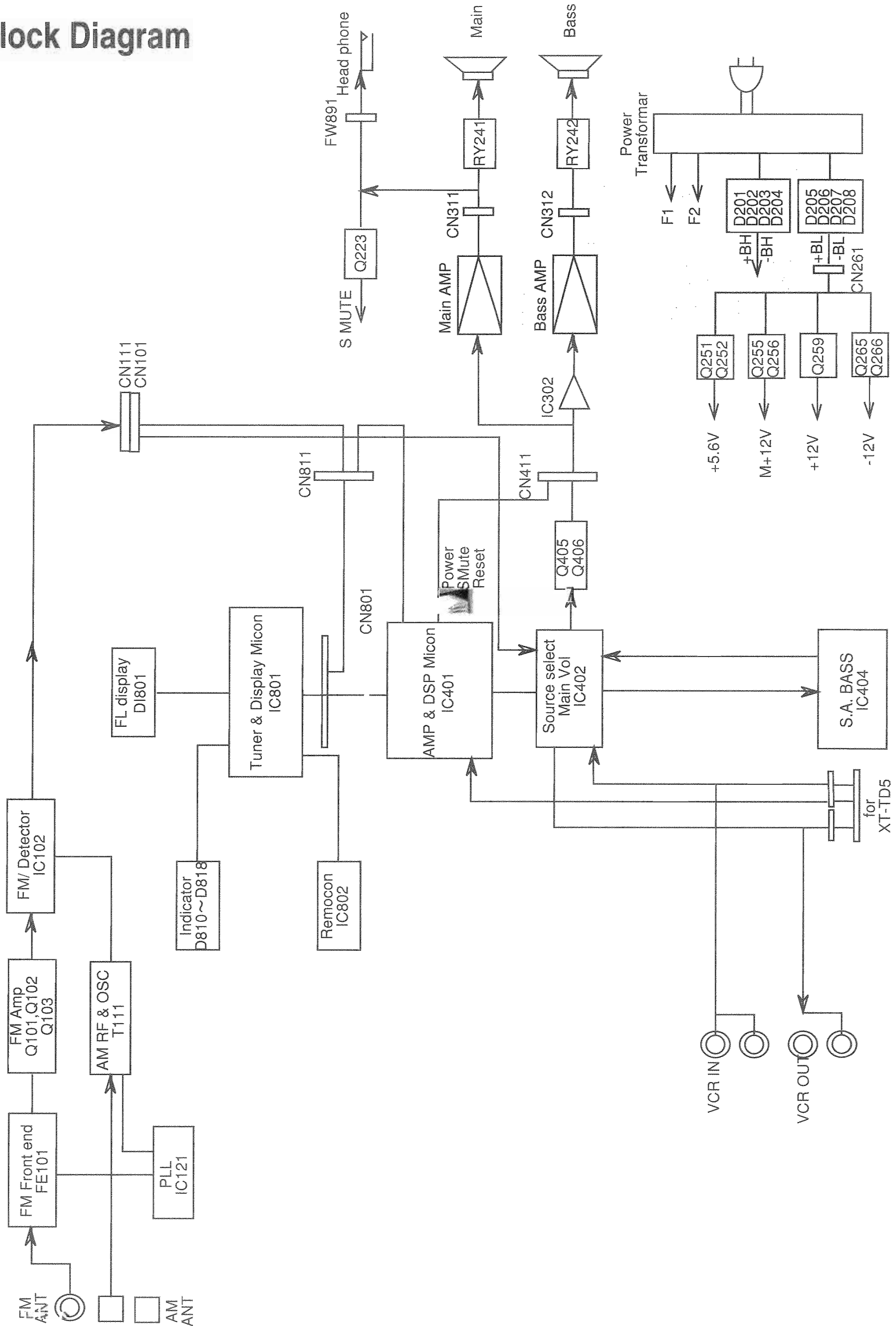

Schematic Diagram

(1) Power Supply Section

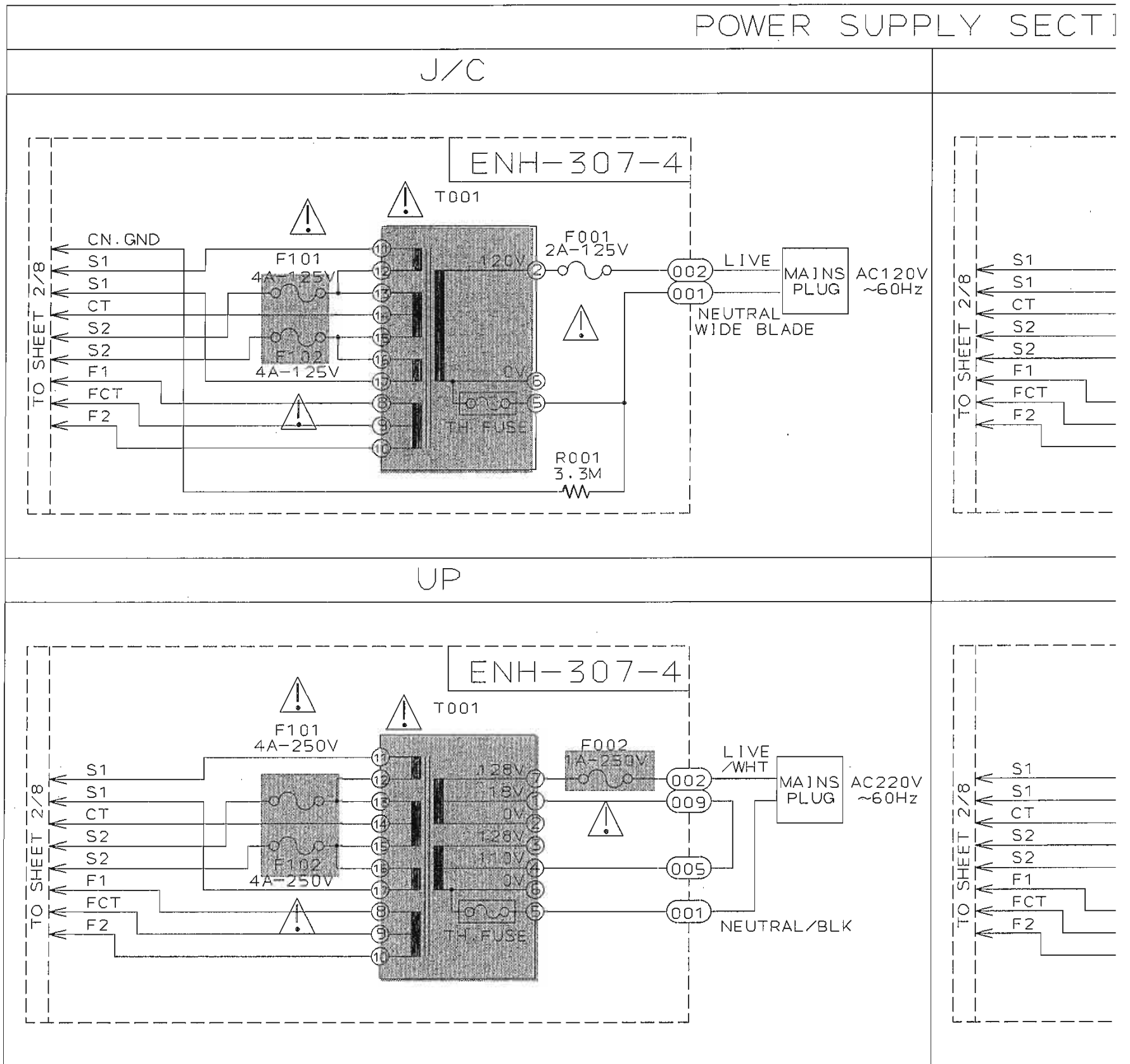

Notes:

1. indicates main signal path.
2. indicates rec. signal path.
3. When replacing the parts in the darkened are () and those marked with , be sure to use the designated parts to ensure safety.
4. This is the standard circuit diagram. The design and contents are subject to change without notice.

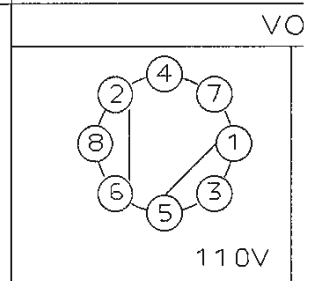

A

B

C

D

CTION

EF/EN/G/BS

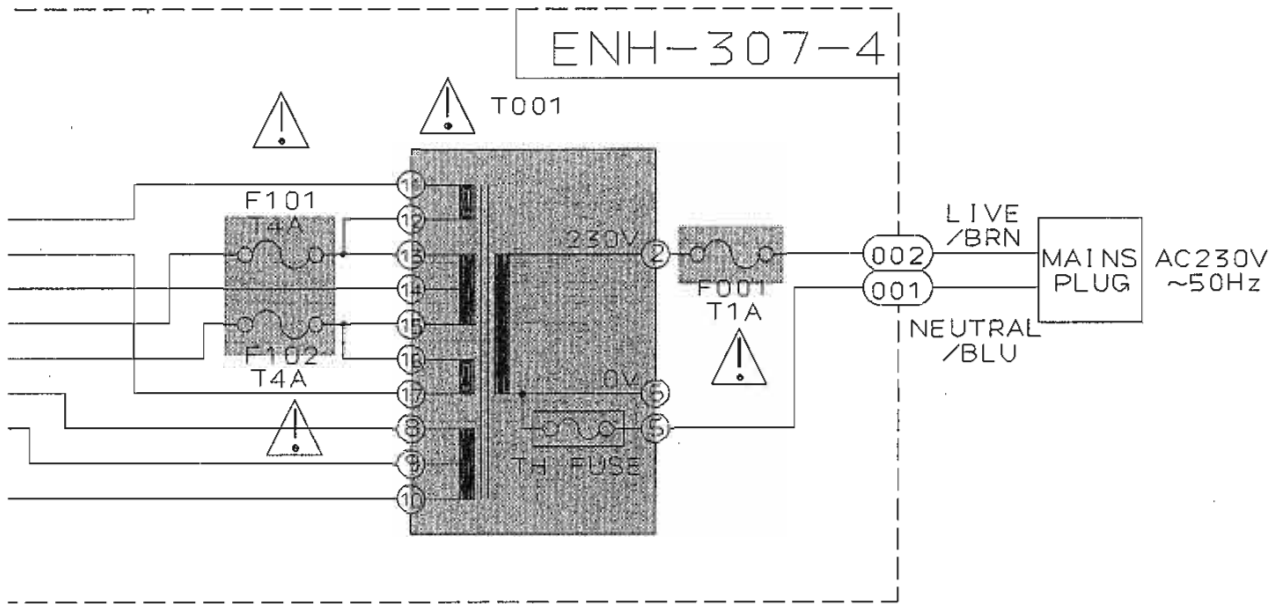

U/UB/US/UT

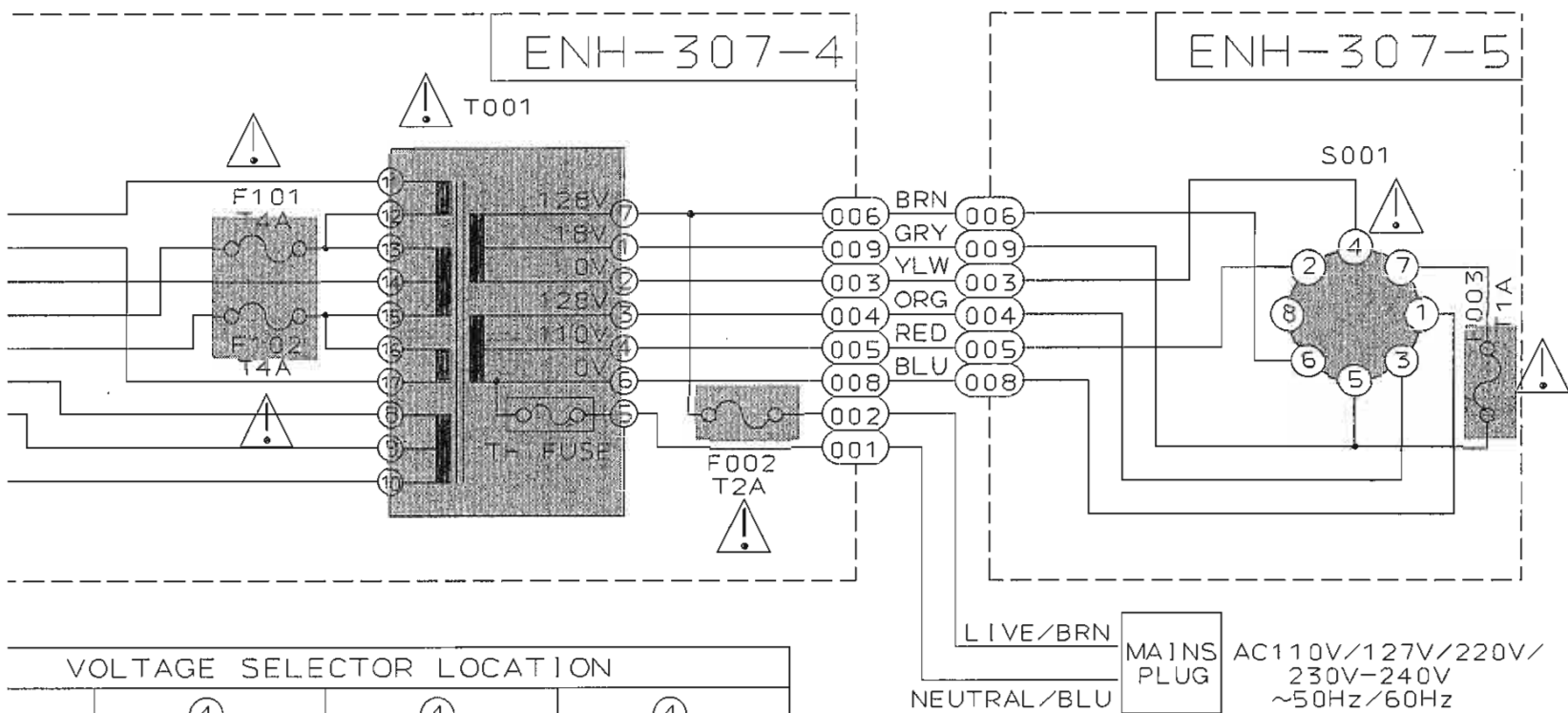

VOLTAGE SELECTOR LOCATION

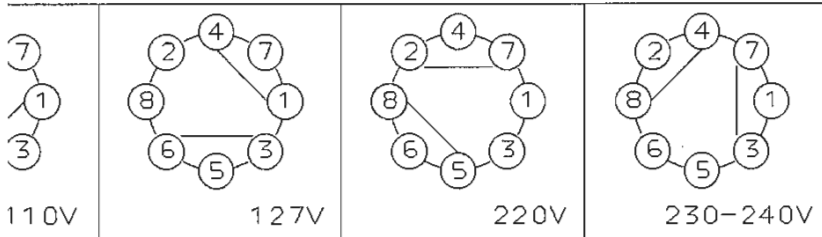

RX-TD5/RX-TD55R

(2) Tuner Section (For J,C)

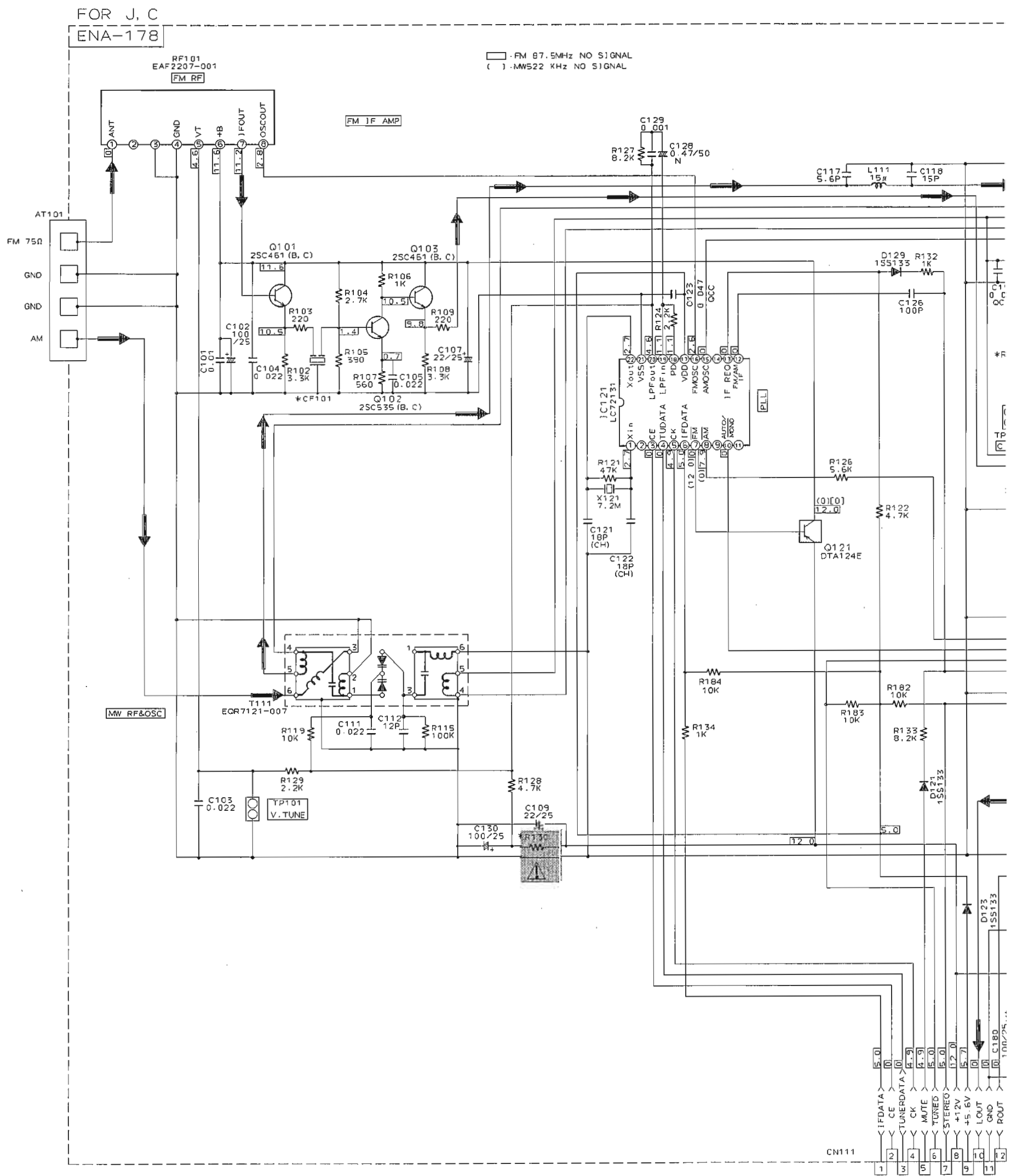

5

4

3

2

1

2-16

A

B

C

D

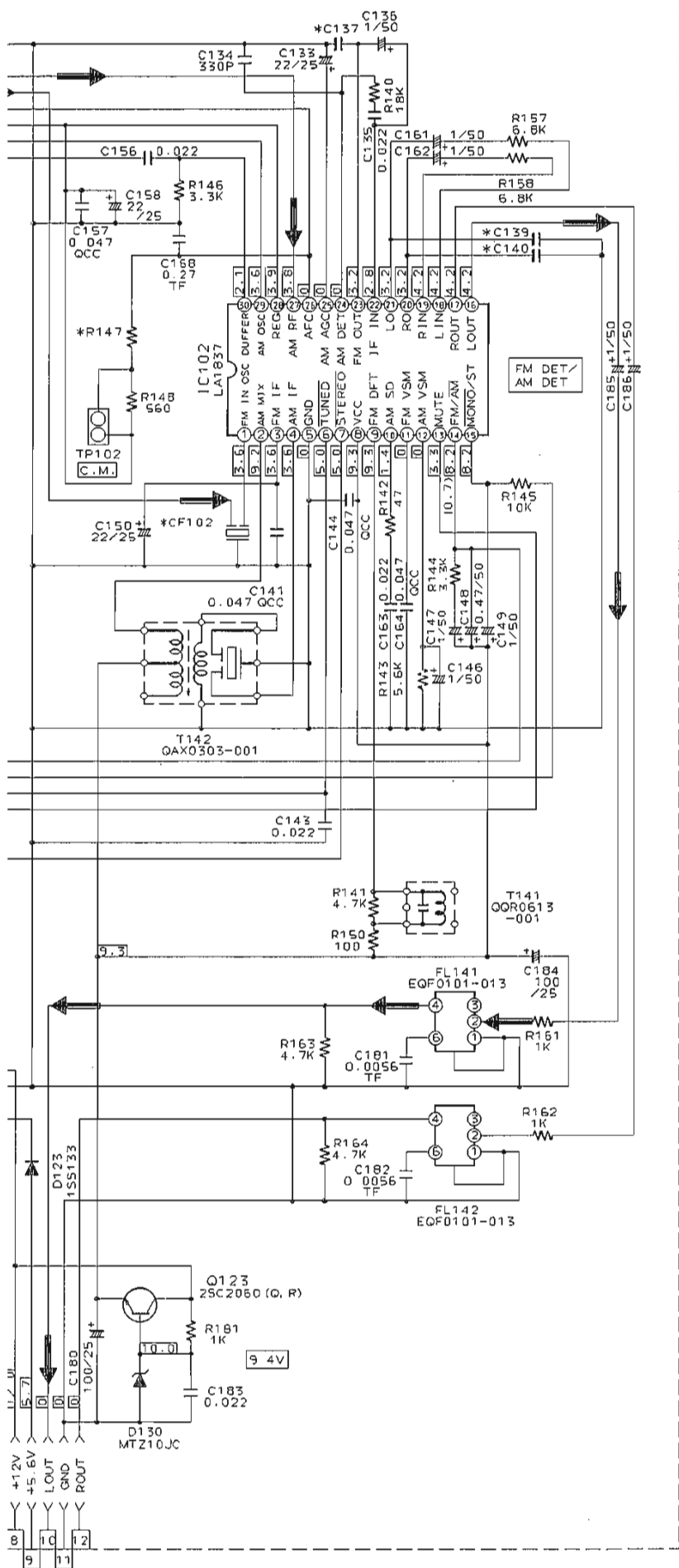

* MARK

	J, C	U, A
C137	680P	560P
C139, 140	0.033TF	0.022TF
CF101, 102	QAX0284-001Z	QAX0285-001Z
R130	68 UNF. C. (1/4W)	58 UNF. F (1/4W)
R147	15K	27K

RF101
EAF2207-001

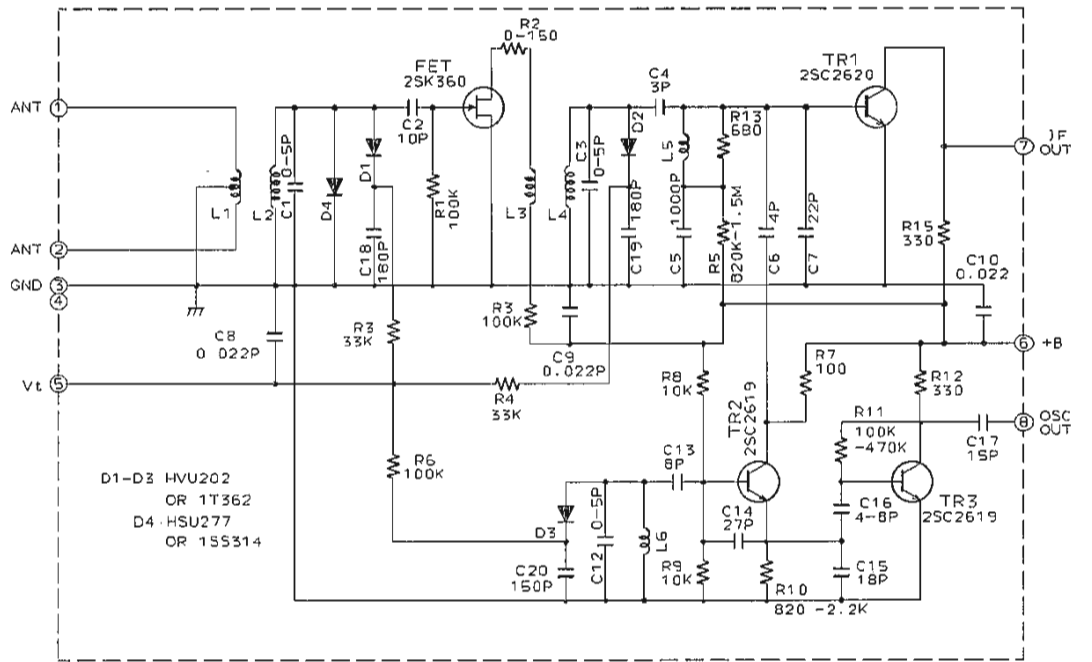

D1-D3 HVU202
OR 1T362
D4 HSU277
OR 1S5314

(3) Tuner Section {For EF, EN, G, BS (Without RDS) }

EF, EN, G, BS (WITHOUT RDS)

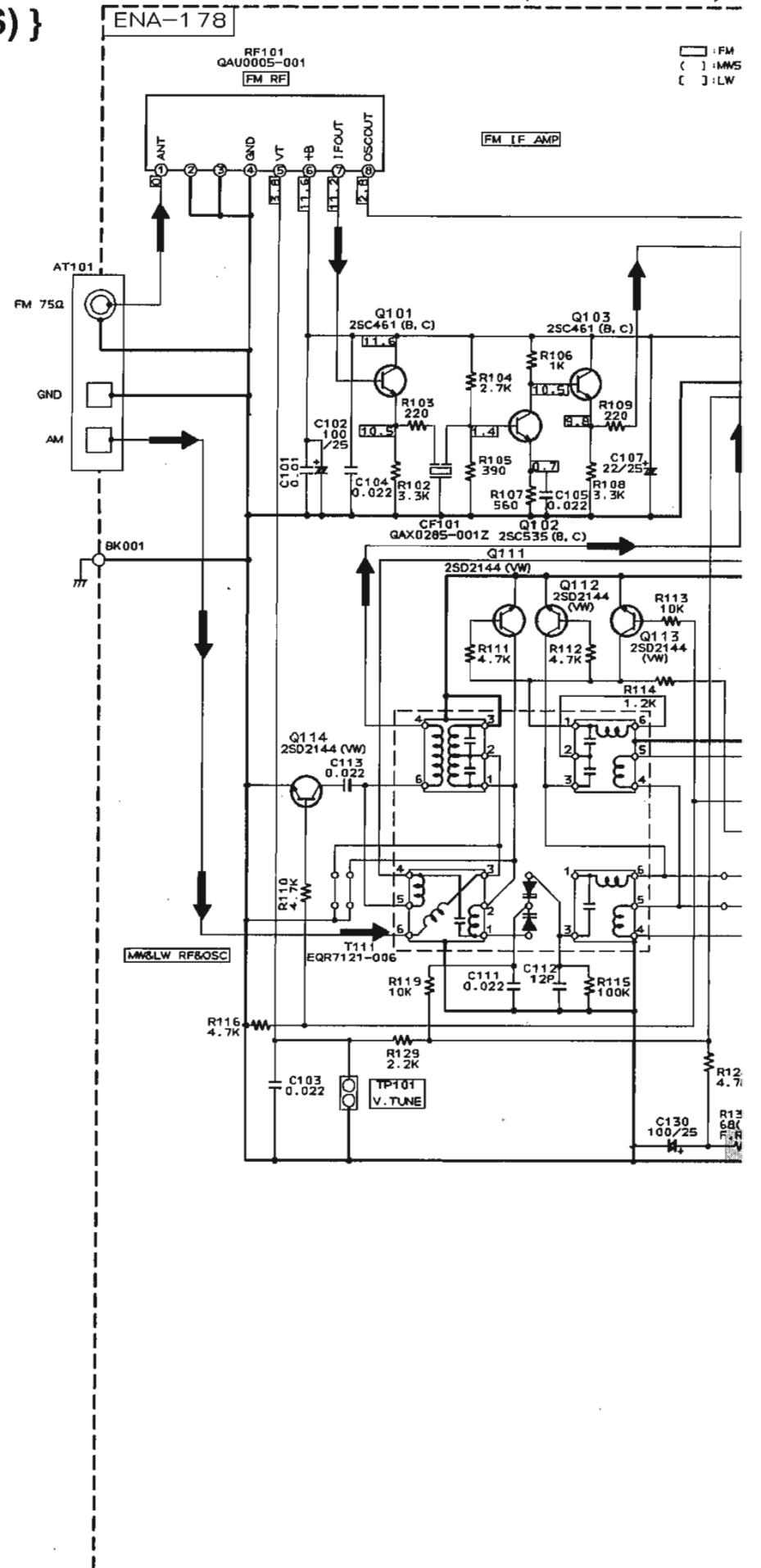

RE101
QAU0005-001

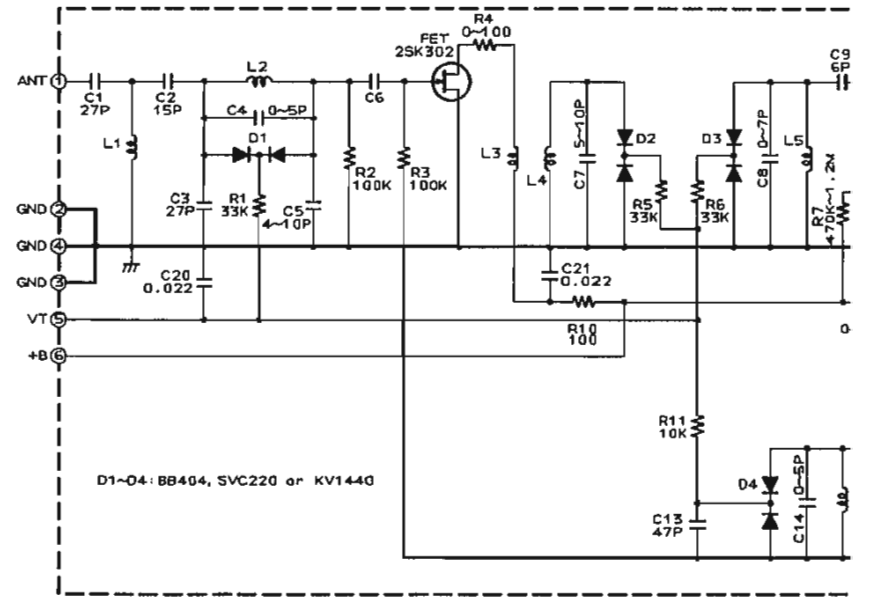

A

B

C

D

5

4

3

2

1

RDS)

- : FM 87.5MHz NO SIGNAL
- () : MW522 KHz NO SIGNAL
- : LW 144KHz NO SIGNAL

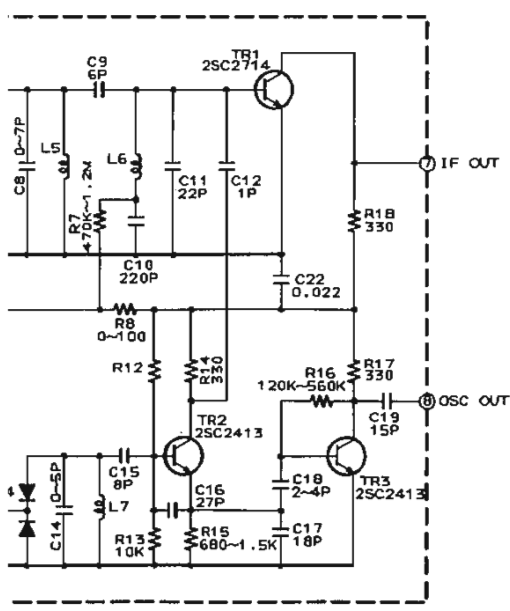
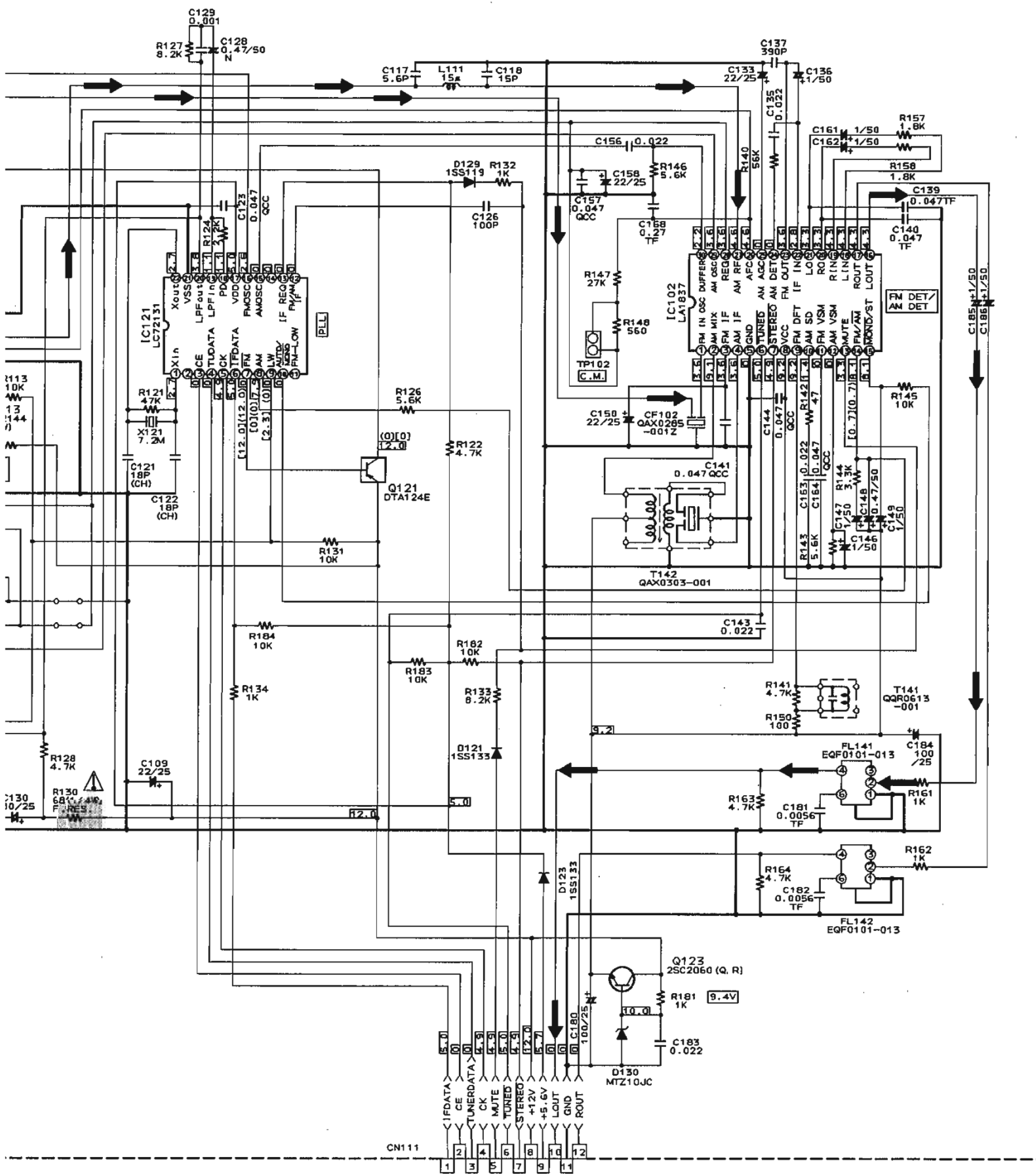

(4) Tuner Section {For EF, EN, G, BS, (With RDS) }

5

4

3

2

1

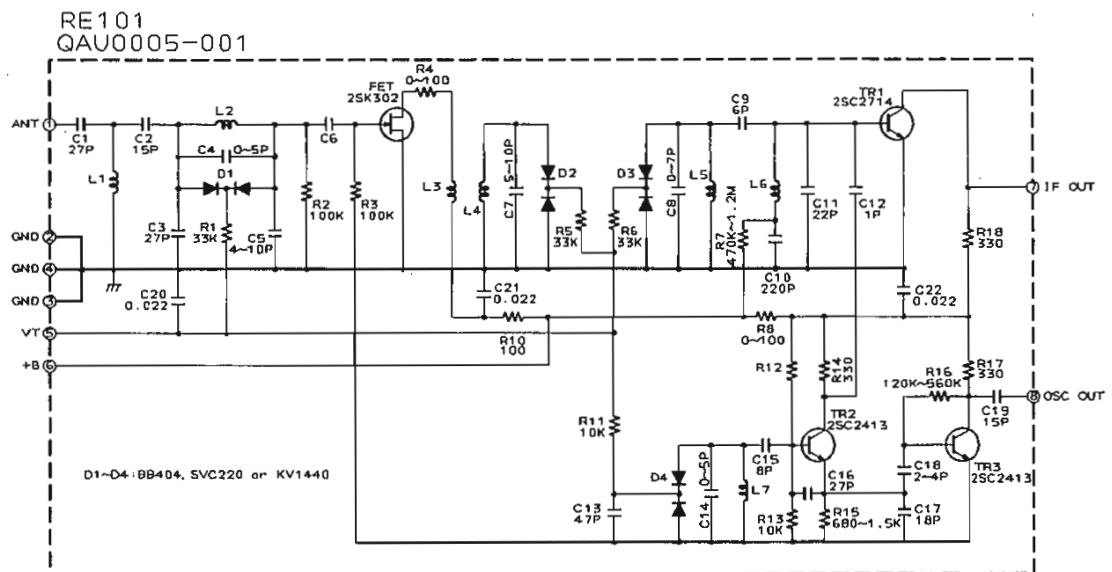
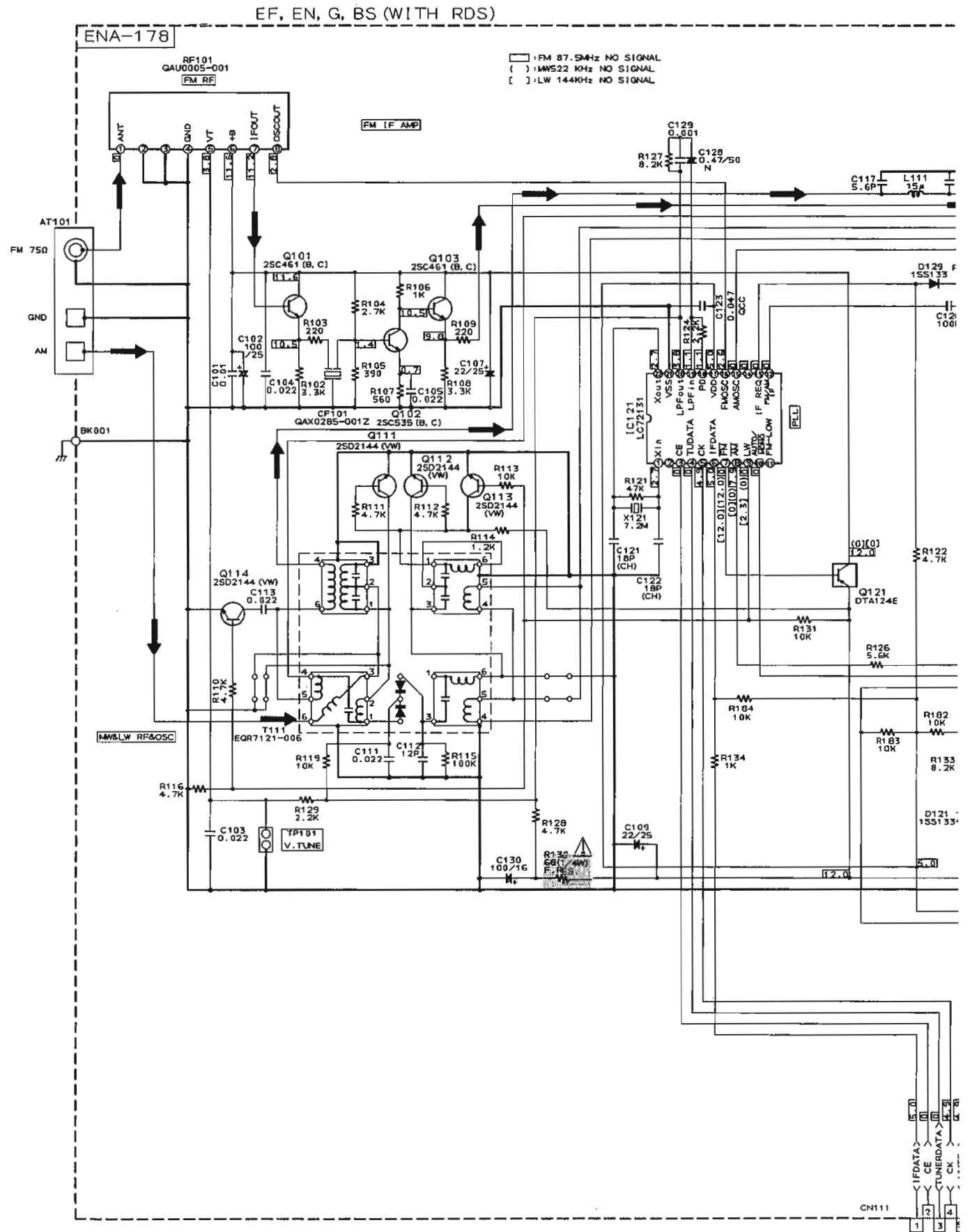

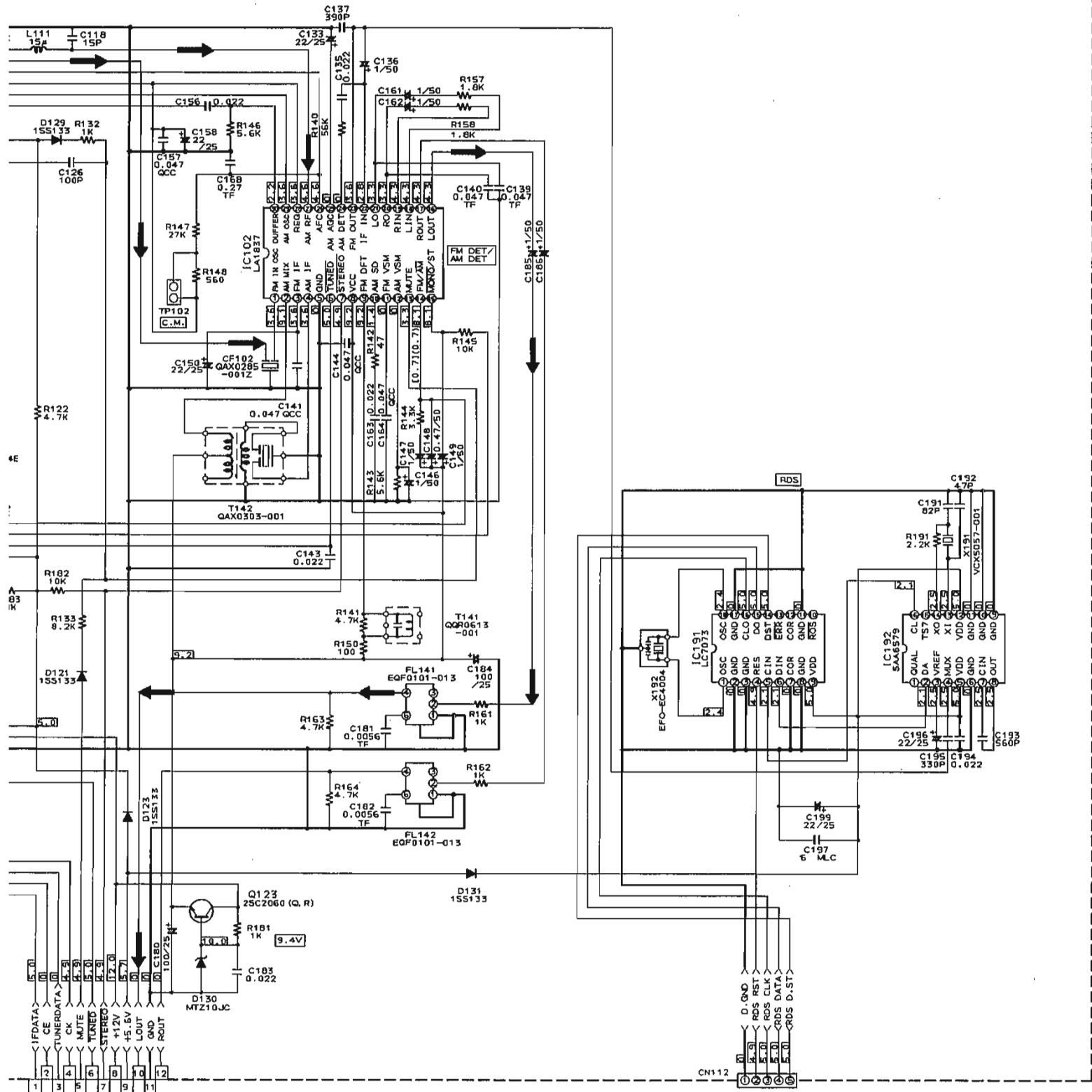

E

F

G

H

(5) Tuner Section (For A, U, UB, US, UT, UP)

5
4
3
2
1

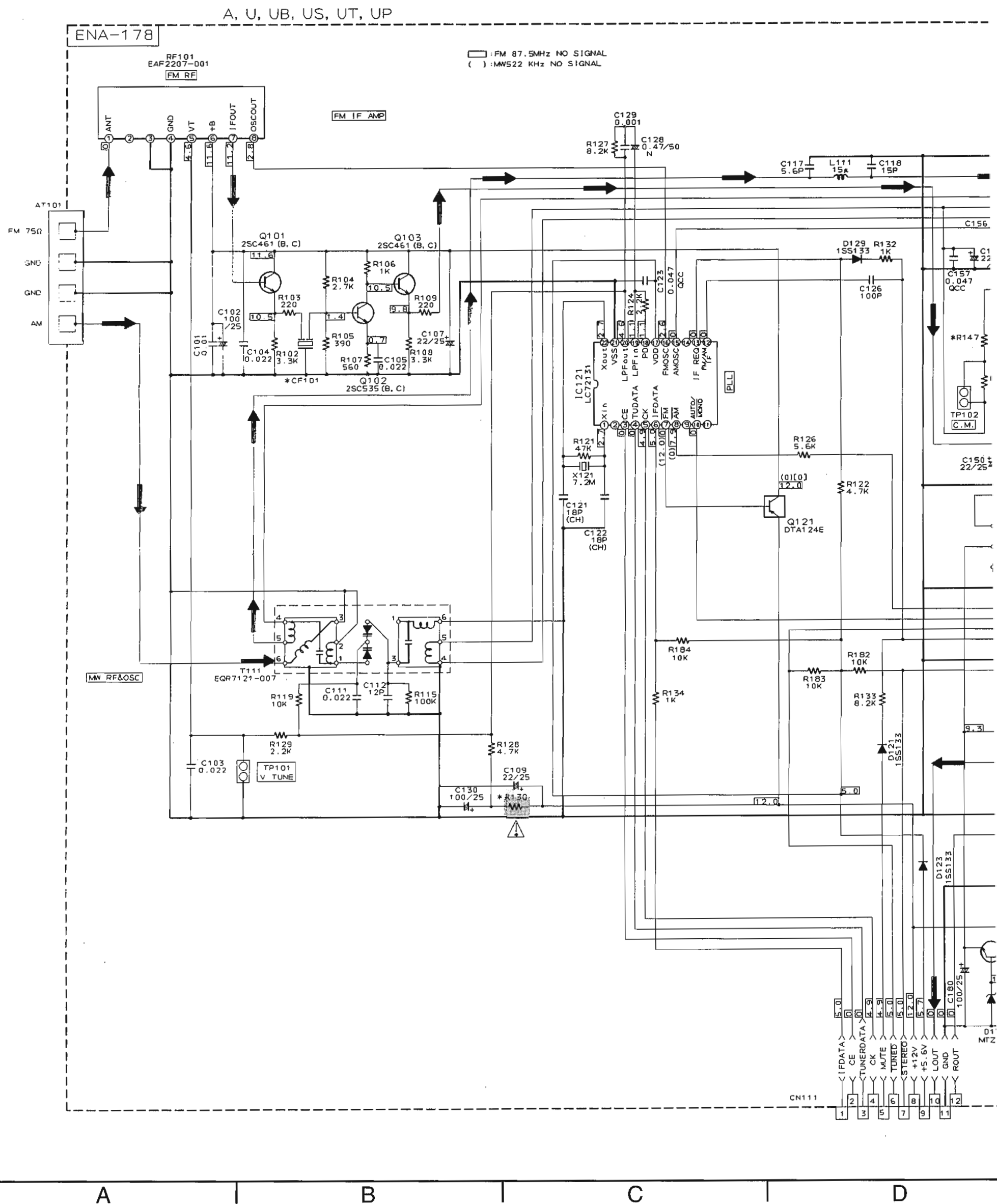

A | B | C | D

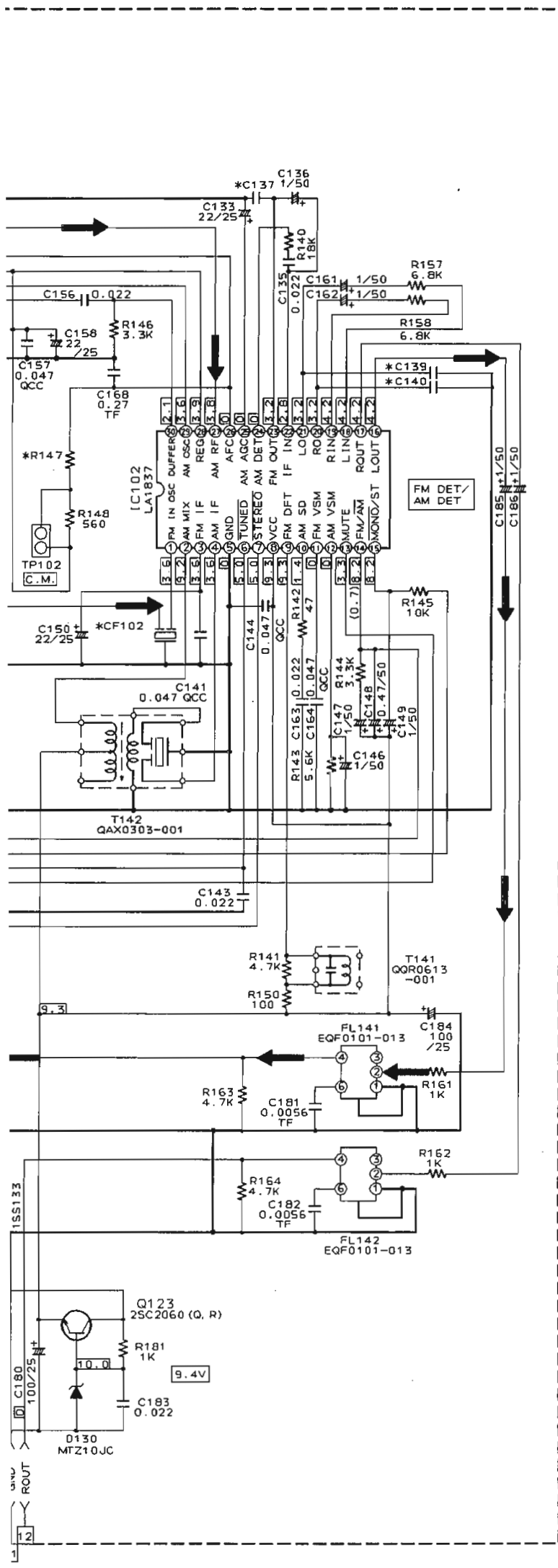

* MARK

	J, C	U, UB, US, UT, UP, A
C137	680P	560P
C139, 140	0.033TF	0.022TF
CF101, 102	QAX0284-001Z	QAX0285-001Z
R130	68 UNF. C. (1/4W)	68 UNF. F. (1/4W)
R147	15K	27K

RF101
EAF2207-001

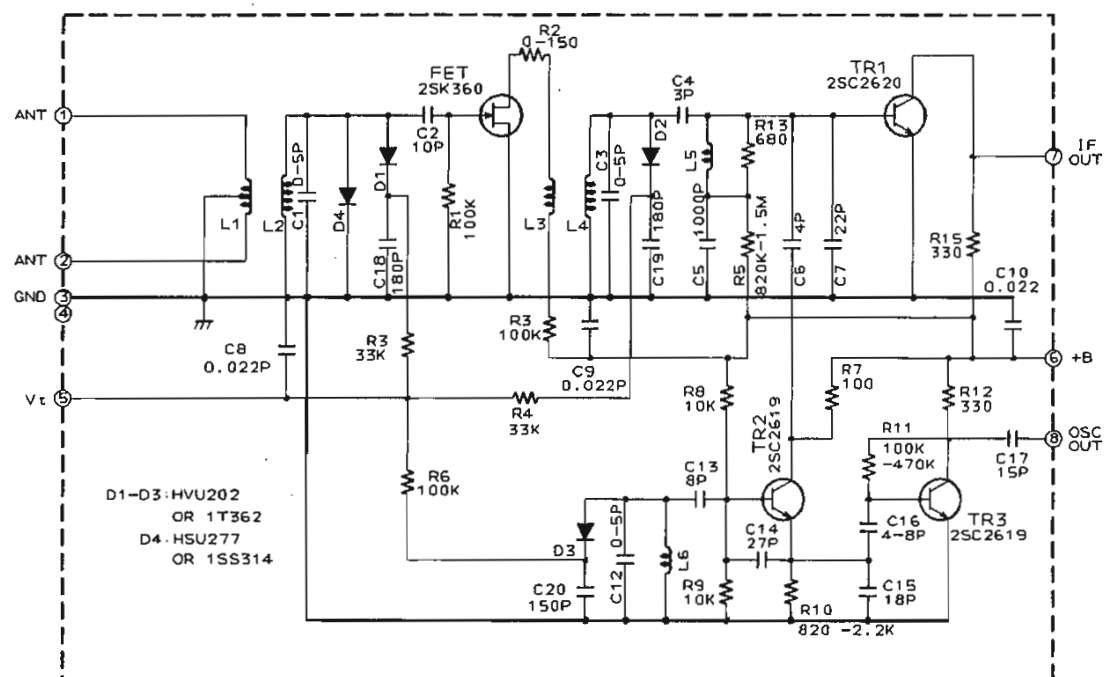

(6) Tuner Section (For VX)

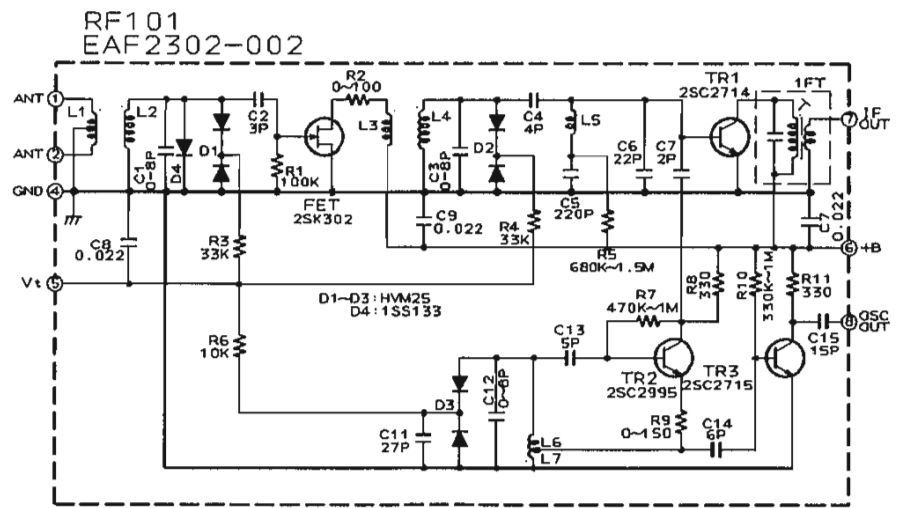
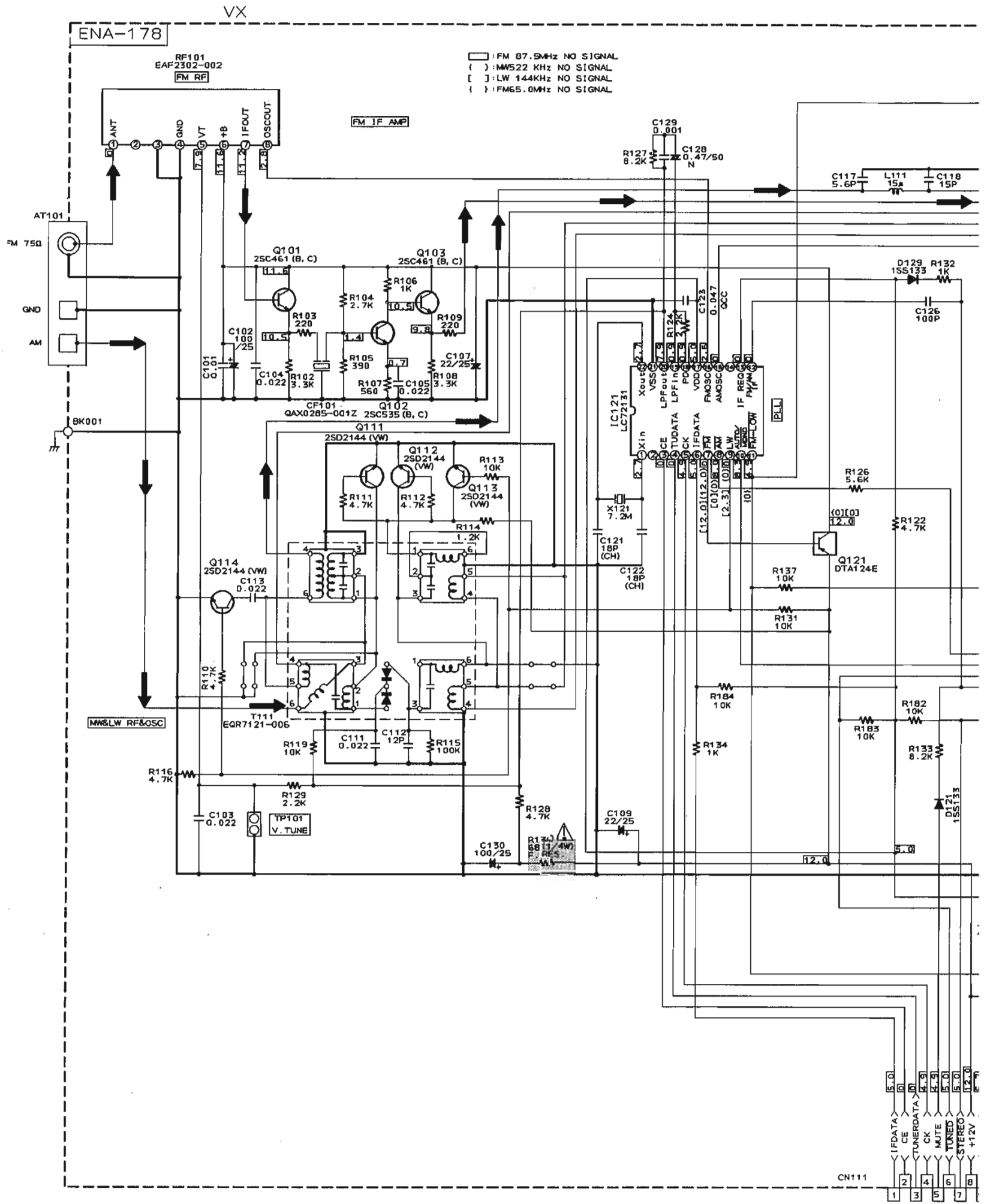

5
4
3
2
1

2-20 A B C D

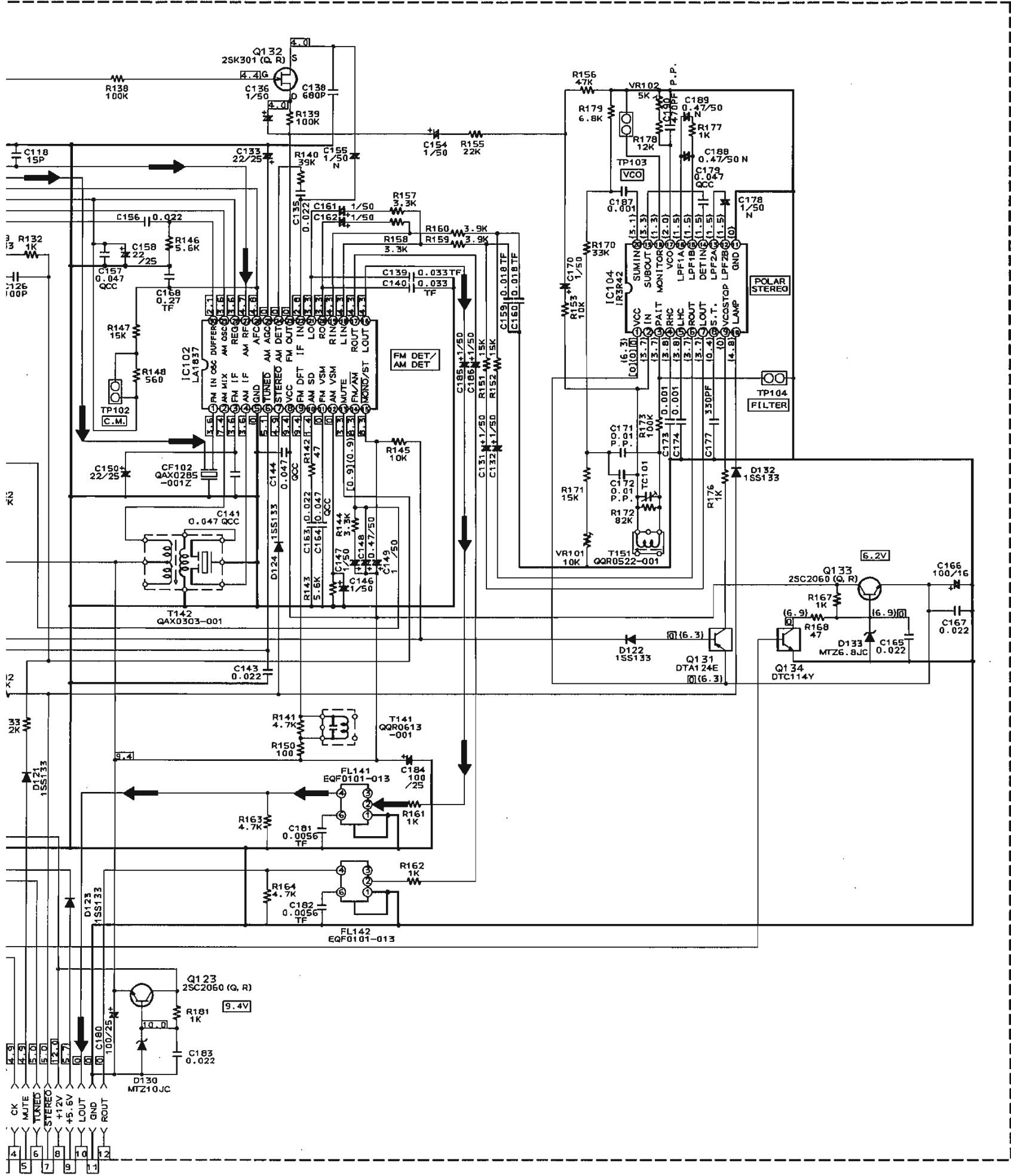

P2-21-a

P2-21-b

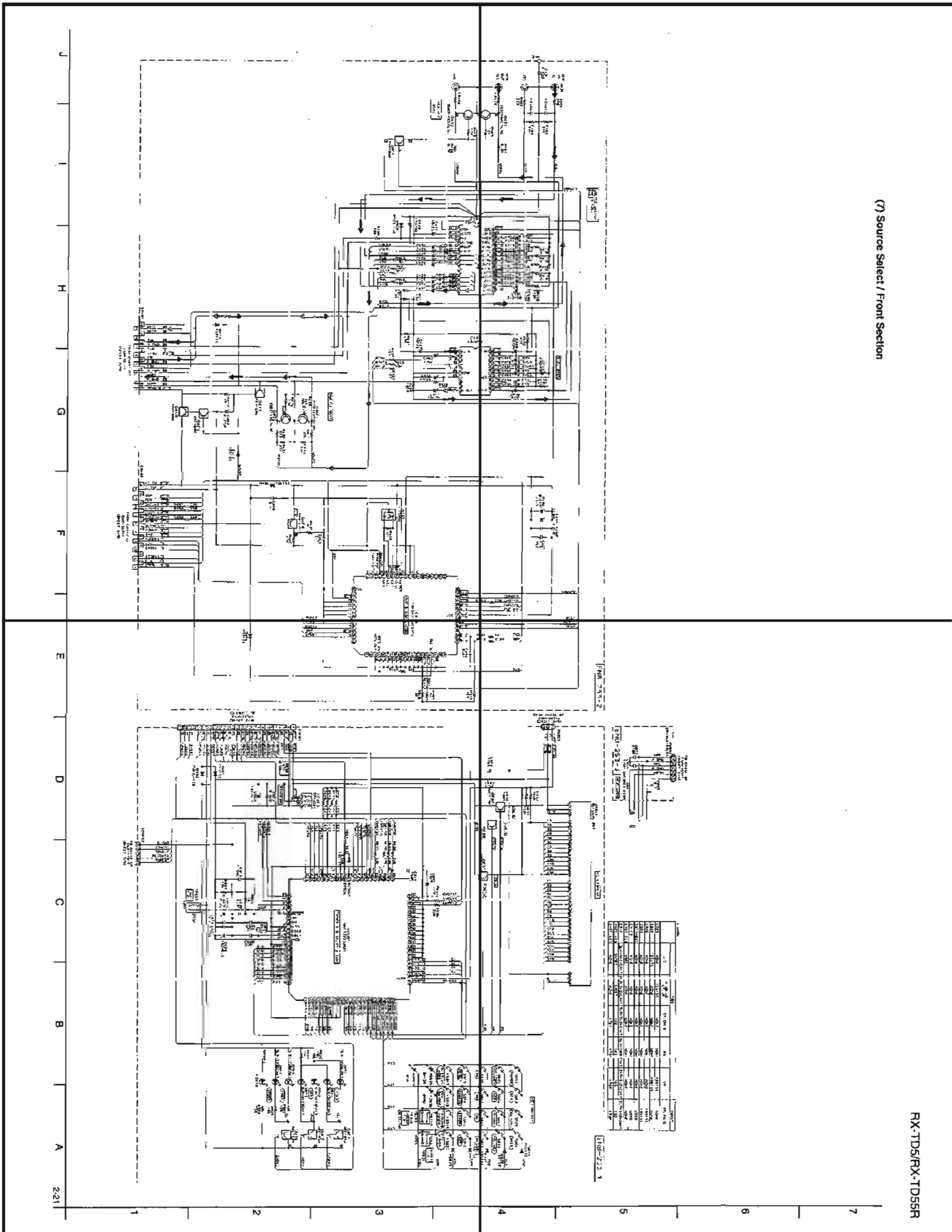

P2-21-c

P2-21-d

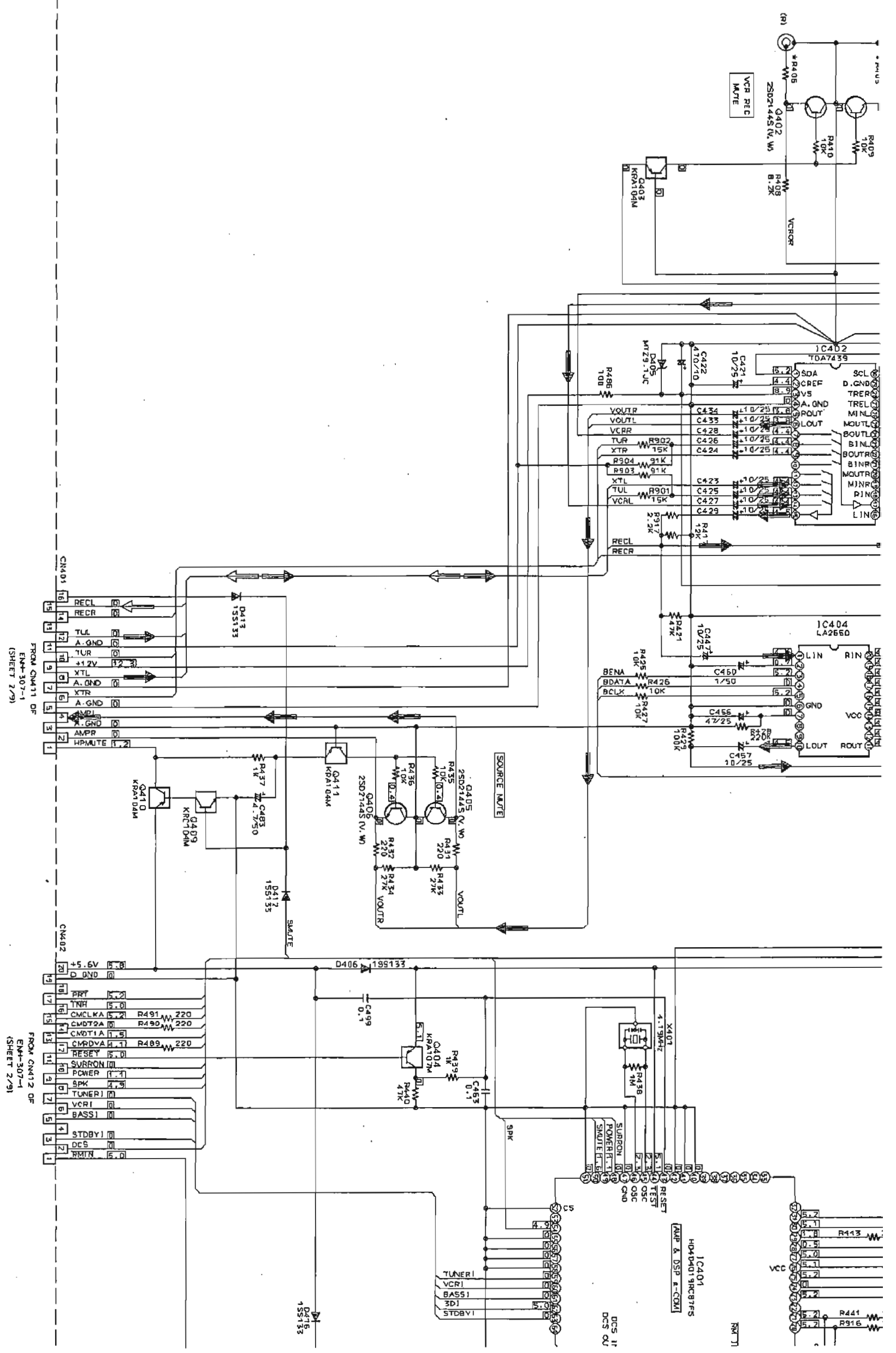

FROM QM411 OF
ENH-307-1
(SHEET 2/9)

FROM QM12 OF
ENH-307-1
(SHEET 2/9)

J I H G F

(7) Source Select / Front Section

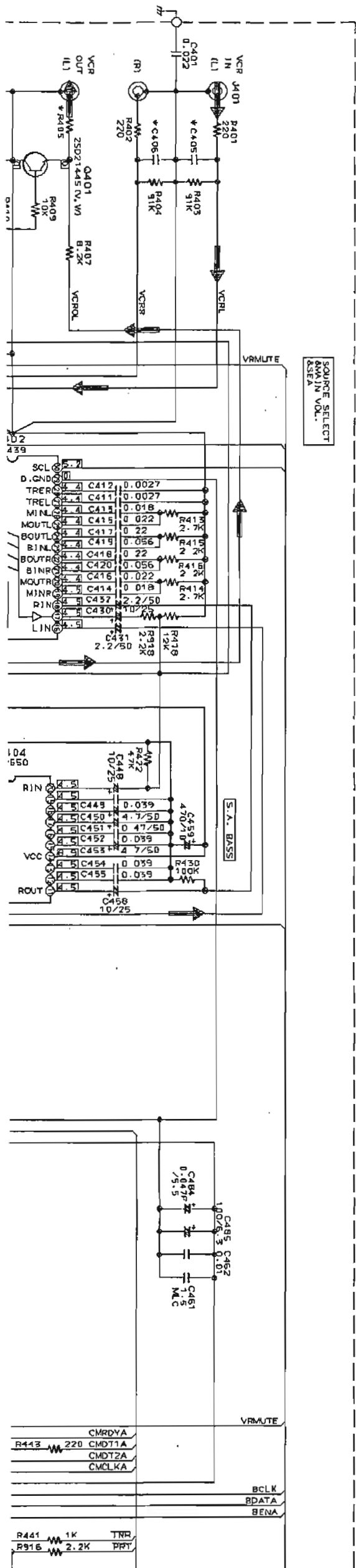

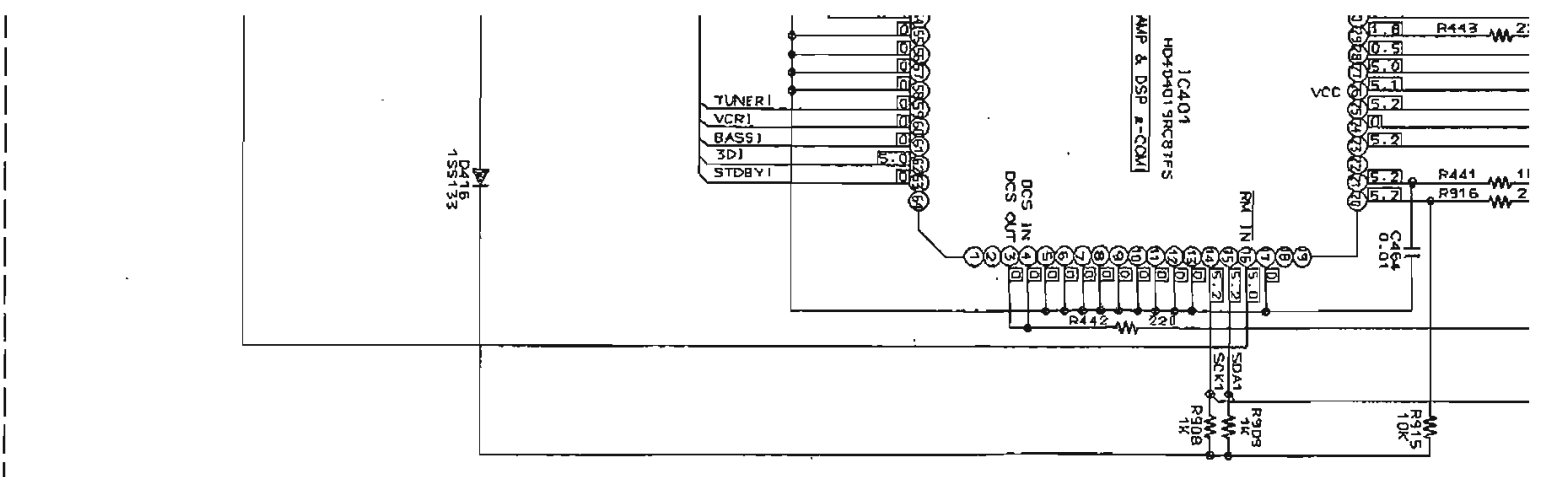
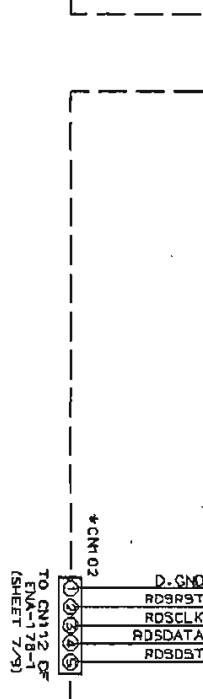
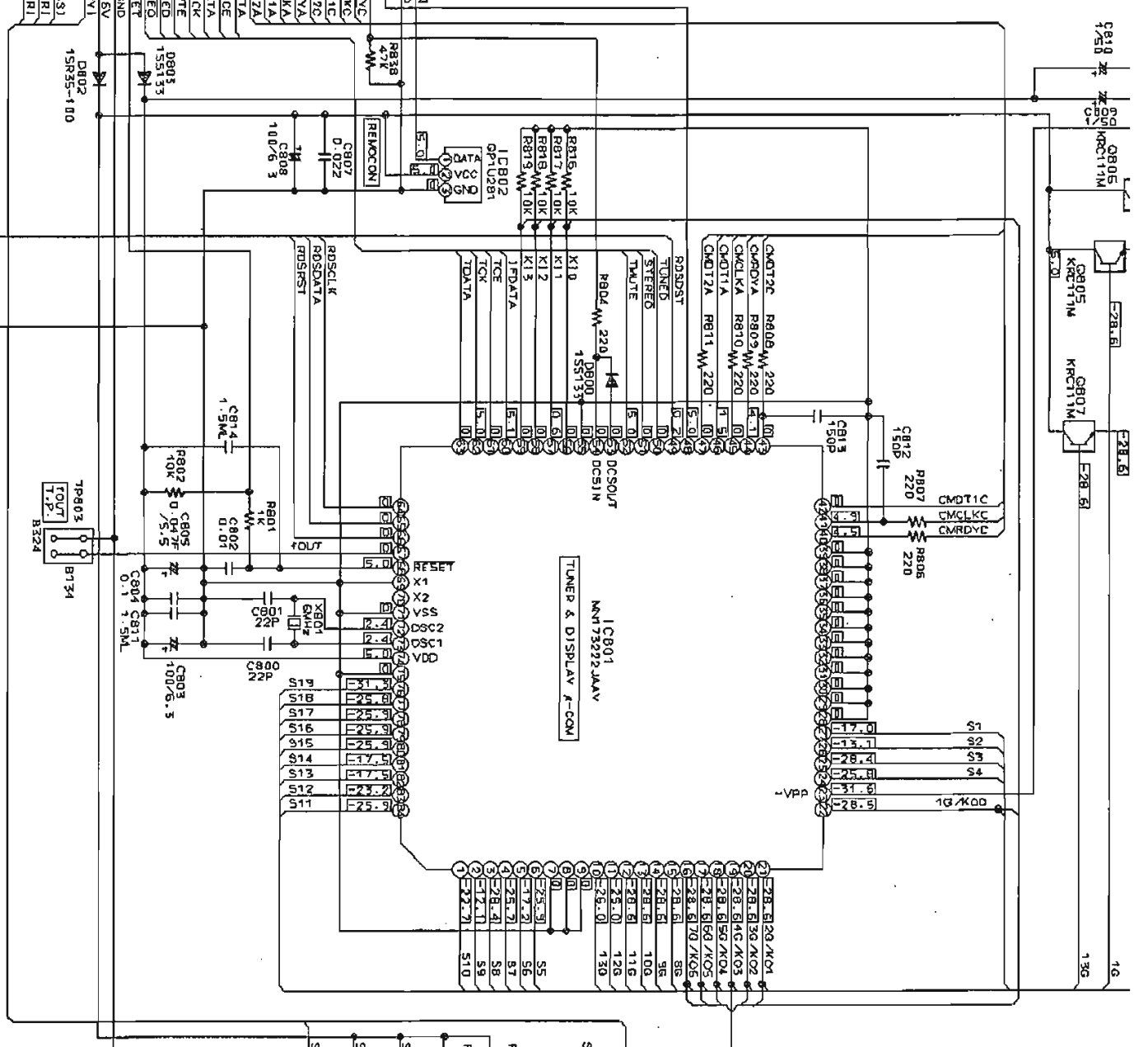
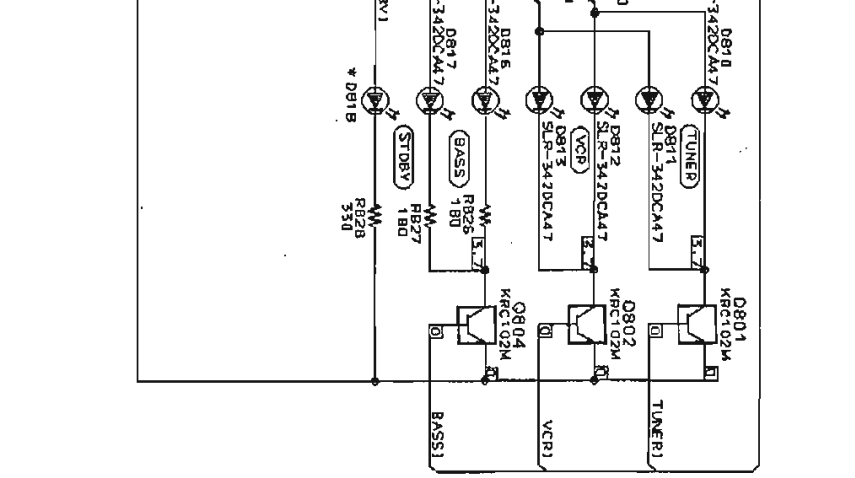
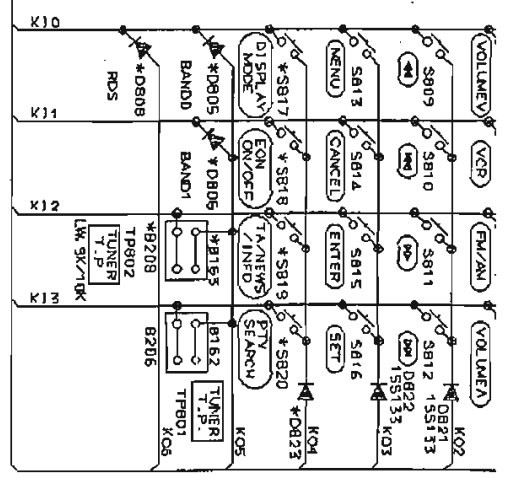

E D C B A 2-21

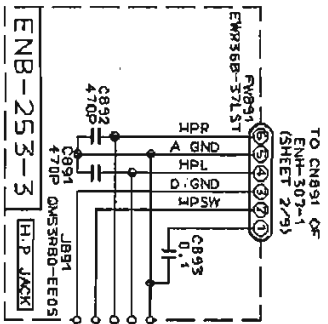

* MARK

	J.C	U, U9, U5, U7, U8	EF, EN, G	B5	VX	TD5SR
D805	NONE	1SS133	NONE	NONE	1SS133	NONE
D806	1SS133	NONE	NONE	NONE	1SS133	NONE
D808	NONE	NONE	NONE	NONE	NONE	1SS133
D823	NONE	NONE	NONE	NONE	NONE	1SS133
S817-820	NONE	NONE	NONE	NONE	NONE	USED
CN102	NONE	NONE	NONE	NONE	NONE	USED
B163, 208	USED	NONE	NONE	NONE	NONE	NONE
D818	SLP-342VCA47	SLP-342VCA47	SLP-342VCA47	SLA-3801 TAA7	SLP-342VCA47	SLP-342VCA47
R405, 406	SHORT	SHORT	100	100	100	100
C405, 406	NONE	NONE	470P	470P	470P	470P

ENB-253-2

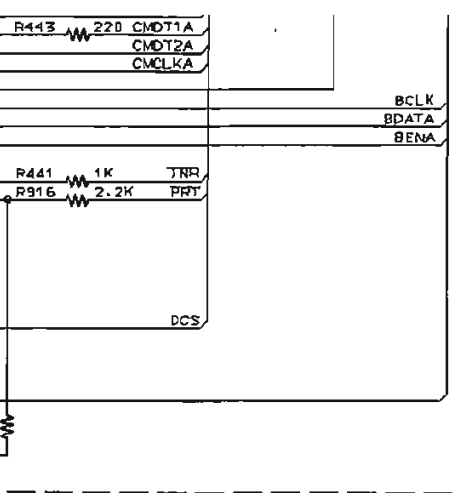

FL DISPLAY

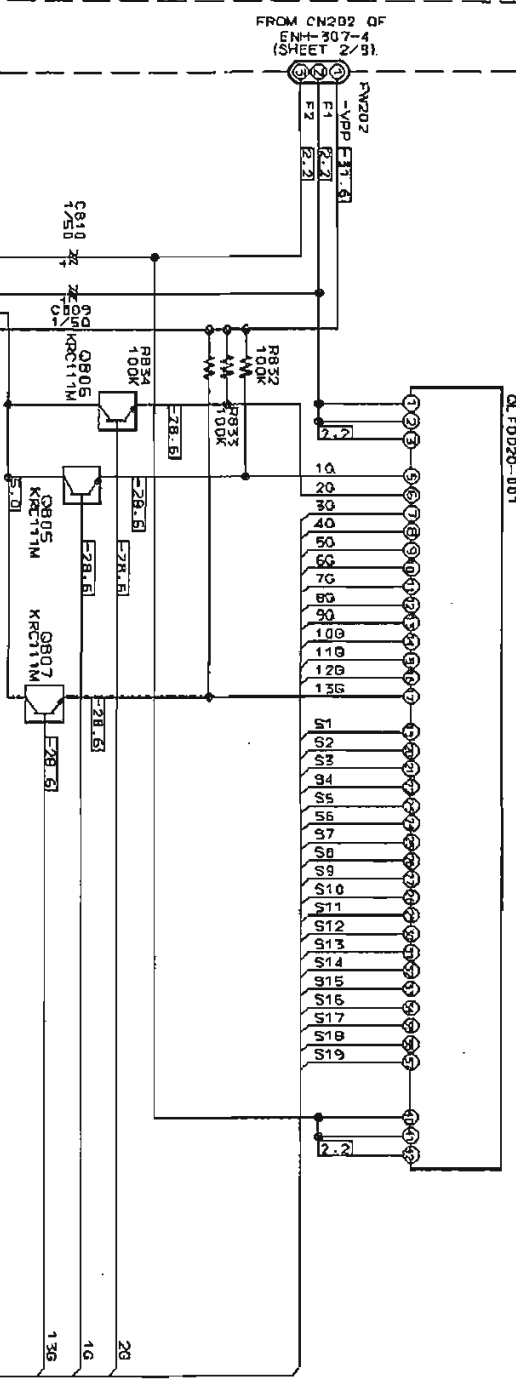

ENB-253-1

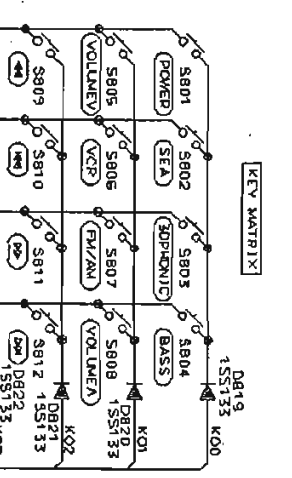

P2-22-a

P2-22-b

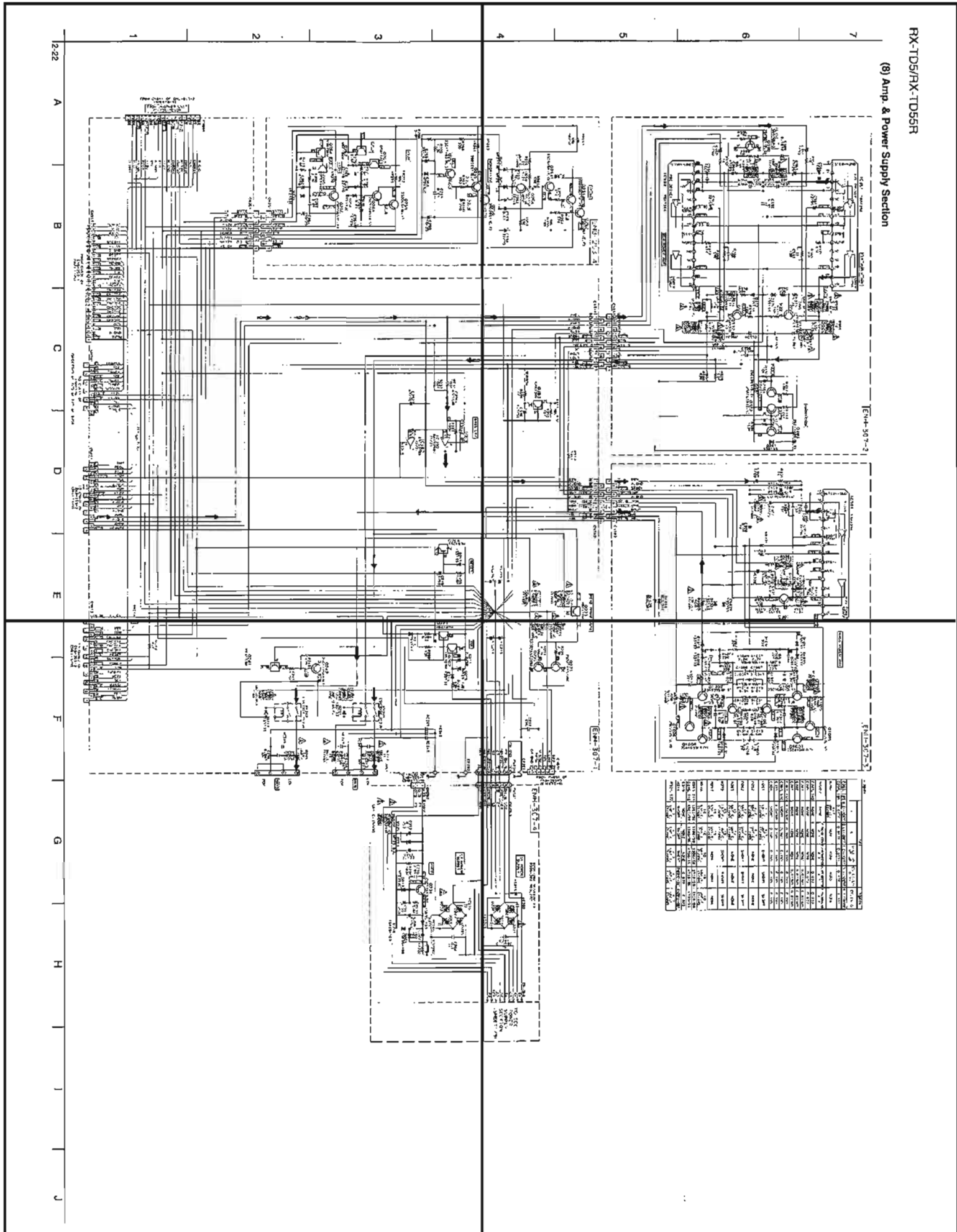

P2-22-c

P2-22-d

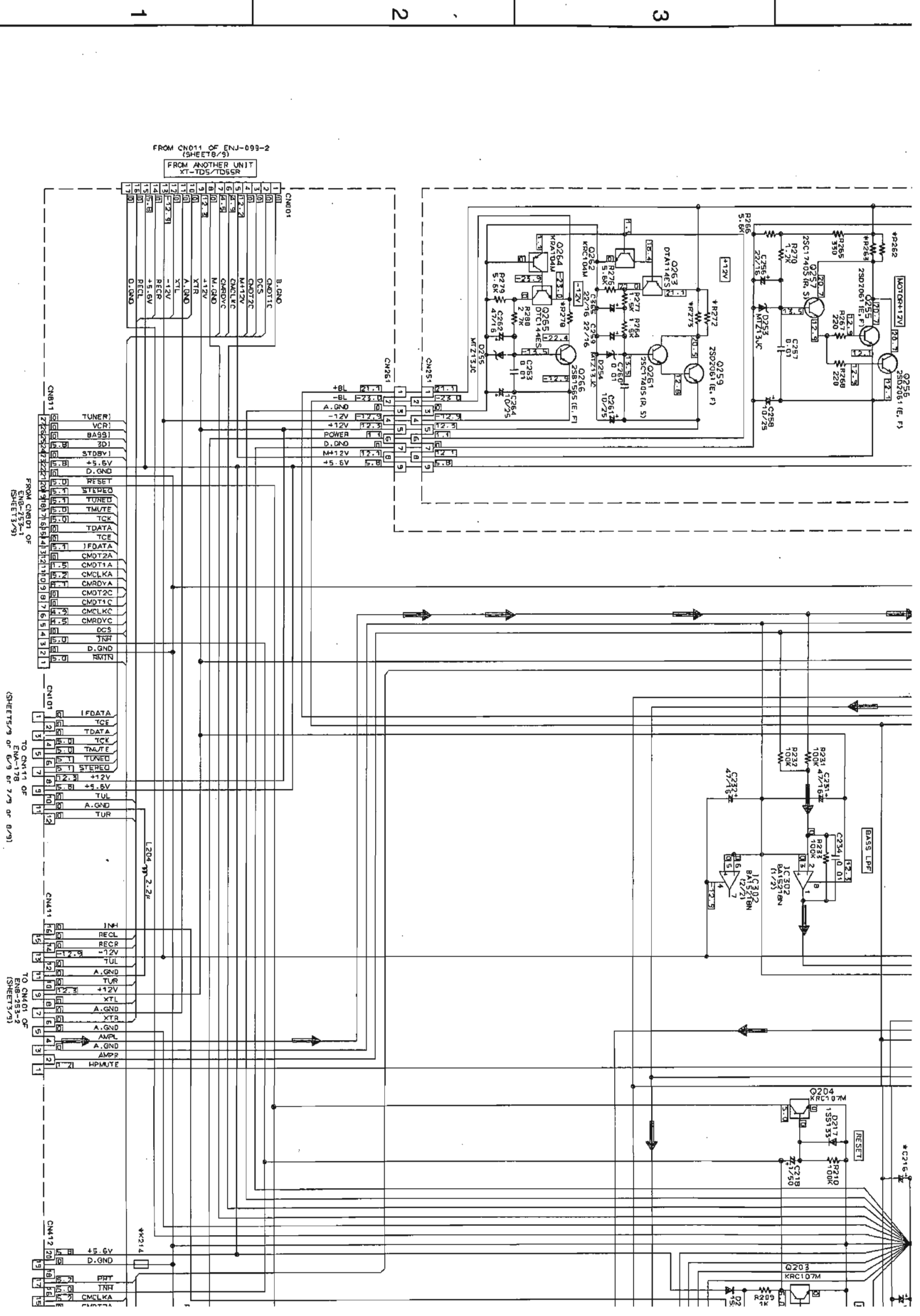

(8) Amp. & Power Supply Section

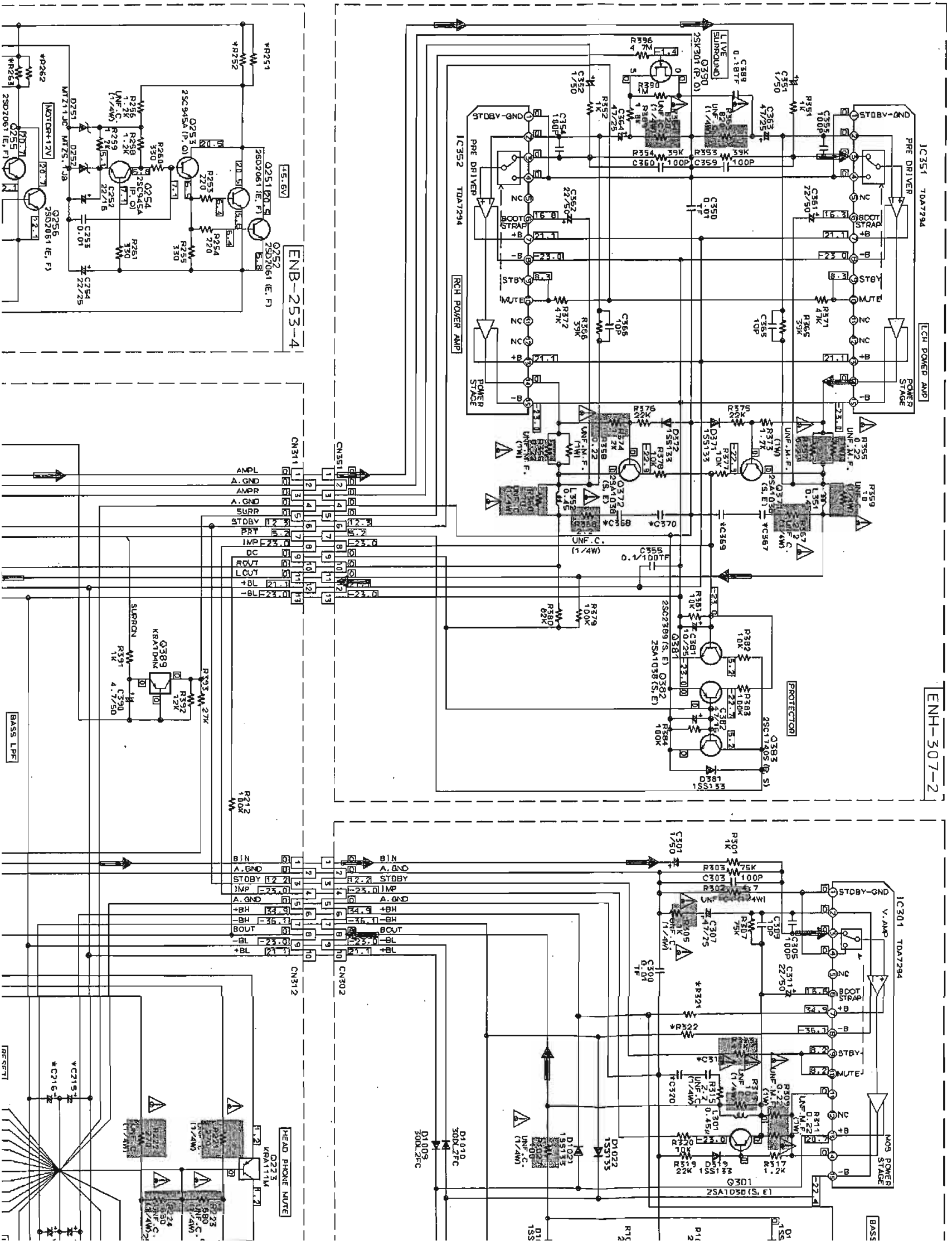

4

5

6

7

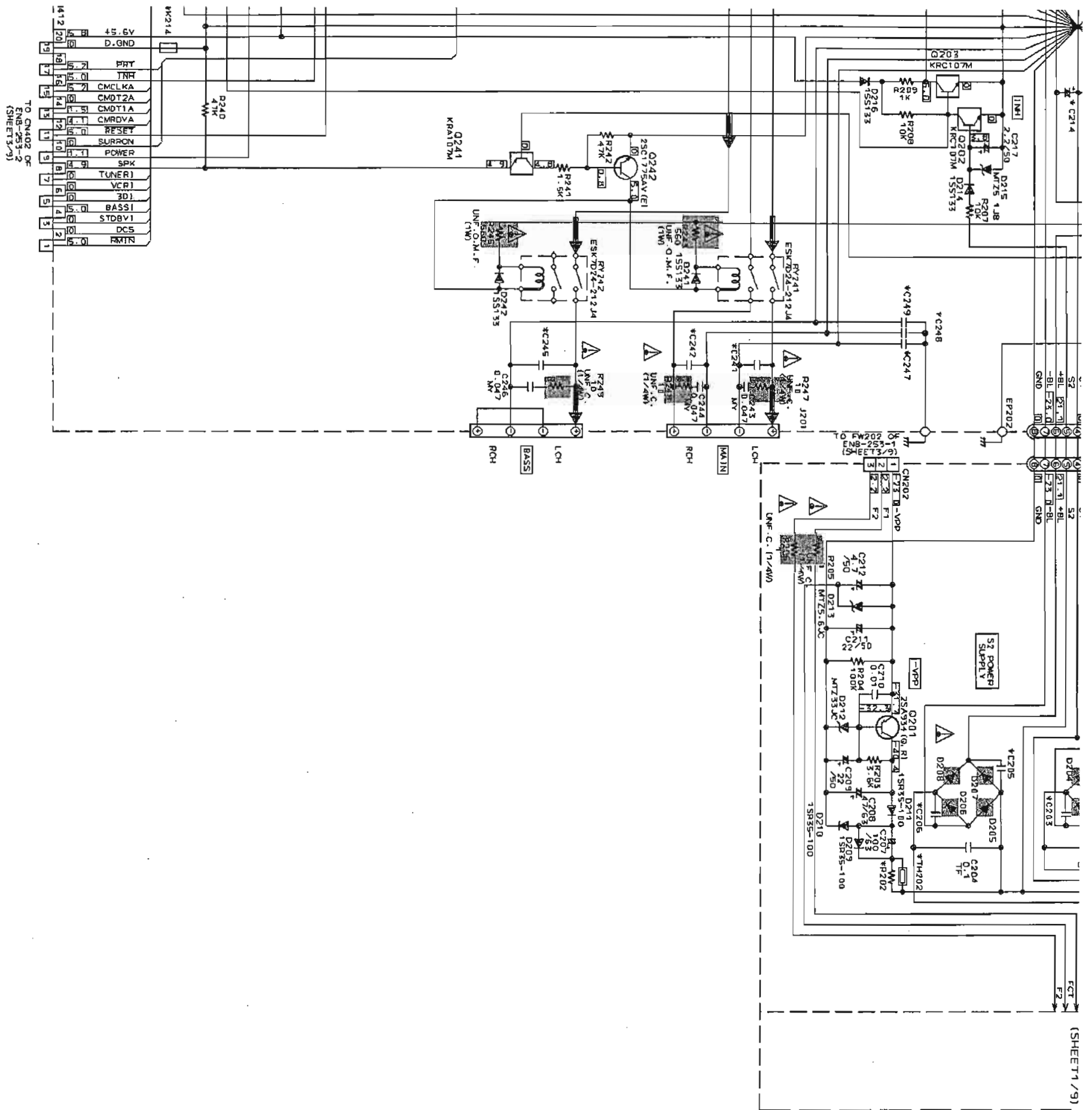

(SHEET 1 / 9)

F G H I J

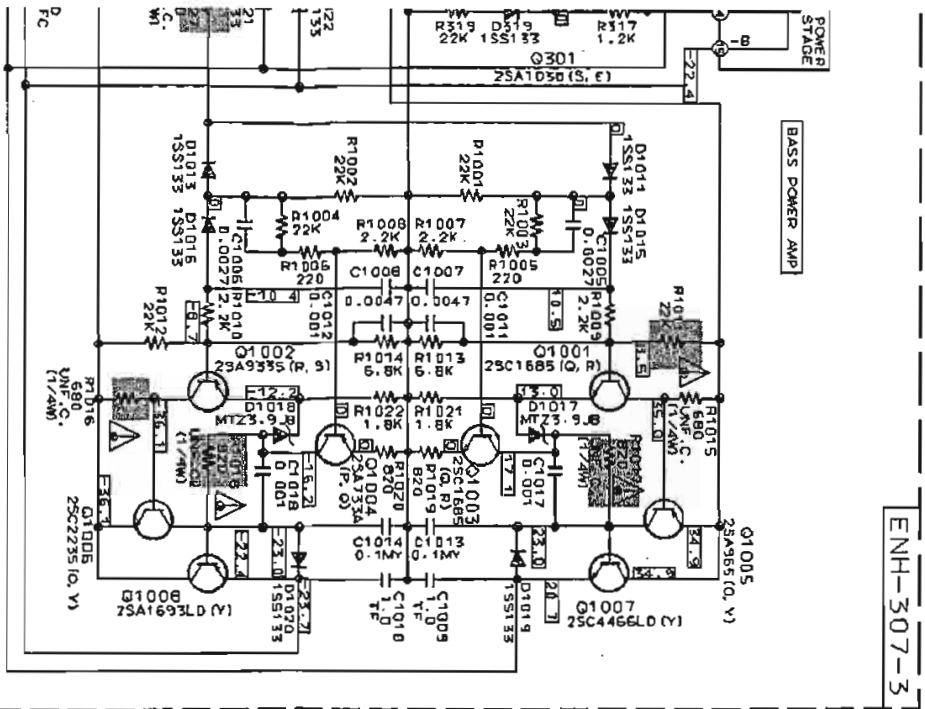

ENH-307-3

* MARK

	J	C	TOS	TOSR
C202, 203	0.01/100T/F	0.01/100T/F	0.01/100T/F	0.01/100T/F
C205, 206	0.01T/F	0.01T/F	0.01T/F	0.1T/F
R202	4.7 UNF. C. (1/4W)	NONE	NONE	NONE
TH20Z	NONE	P-THERMAL STOPP. THERMAL STOPP.	NONE	NONE
C241, 242	NONE	NONE	4.7	0.022
C245	NONE	NONE	NONE	0.022
C247	NONE	NONE	NONE	0.039WV
C248	NONE	NONE	NONE	0.039WV
C249	NONE	NONE	NONE	0.039WV
C367, 368	0.047WV	0.1WV	0.1WV	0.1WV
C369, 370	SHORT	0.1WV	0.1WV	0.1WV
C319	SHORT	0.1WV	0.1WV	0.1WV
C320	SHORT	0.1WV	0.1WV	0.1WV
R251	4.7 UNF. C. (1/4W)	4.7 UNF. C. (1/4W)	SHORT	SHORT
R252	4.7 UNF. C. (1/4W)	4.7 UNF. C. (1/4W)	NONE	NONE
R262	1.2 UNF. C. (1/4W)	1.2 UNF. C. (1/4W)	SHORT	SHORT
R263	1.2 UNF. C. (1/4W)	1.2 UNF. C. (1/4W)	NONE	NONE
R272	1.5 UNF. C. (1/4W)	1.5 UNF. C. (1/4W)	SHORT	SHORT
R273	1.5 UNF. C. (1/4W)	1.5 UNF. C. (1/4W)	SHORT	SHORT
D278	1.0 UNF. C. (1/4W)	1.0 UNF. C. (1/4W)	NONE	NONE
C215, 214	2200/50	2200/50	3300/50	3300/50
C215, 216	3300/35	3300/35	4700/35	4700/35
C219	NONE	NONE	NONE	0.022
K218	SHORT	SHORT	INVERTER-OUT	EXTERIOR-807
R321, 322	4.7 UNF. C. (1/4W)	4.7 UNF. C. (1/4W)	4.7 UNF. C. (1/4W)	4.7 UNF. C. (1/4W)

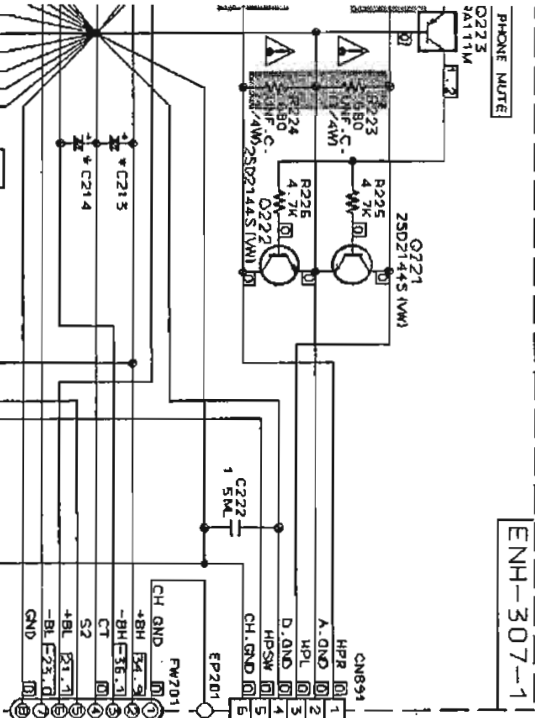

ENH-307-1

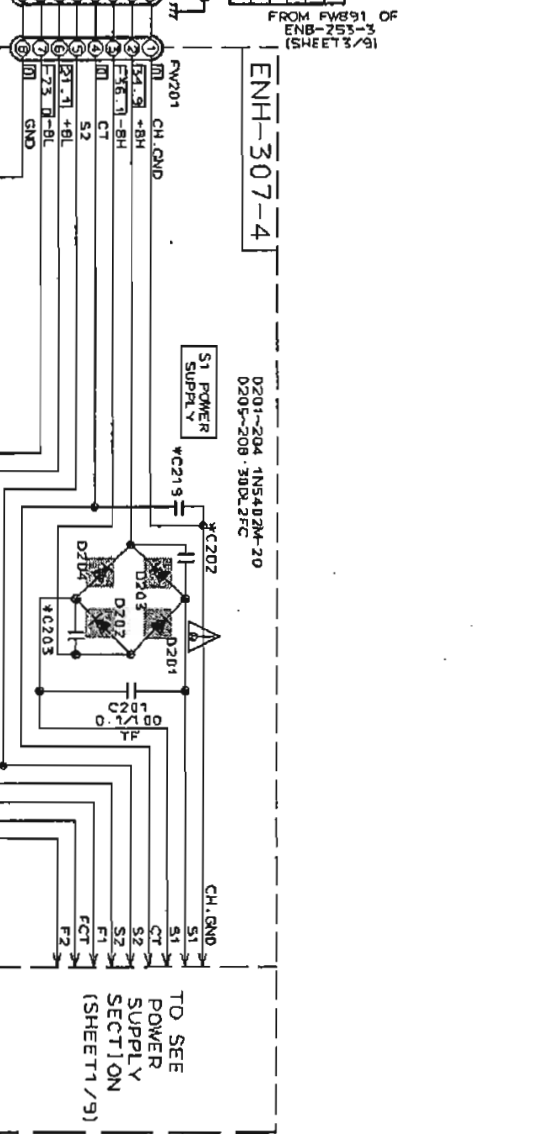

ENH-307-4

■ Location List (ENB-253)

Symbol	X	Y	Symbol	X	Y	Symbol	X	Y	Symbol	X	Y	Symbol	X	Y	Symbol	X	Y
C251	10	G	C460	3	E	D409	1	C	Q803	1	I	R441	10	C	R827	1	J
C252	9	G	C461	9	C	D410	1	C	Q804	1	J	R442	8	B	R828	6	J
C253	9	H	C462	9	C	D412	6	B	Q805	7	F	R443	7	B	R829	4	H
C254	9	G	C463	7	C	D413	3	A	Q806	7	F	R444	8	D	R830	4	H
C256	9	I	C464	9	C	D414	7	D	Q807	5	F	R445	8	D	R831	4	H
C257	9	I	C465	3	B	D415	6	B	R251	9	G	R446	8	D	R832	7	F
C258	9	H	C466	2	B	D416	8	A	R252	9	G	R447	8	D	R833	7	F
C259	9	H	C467	5	D	D417	6	B	R253	9	G	R448	8	D	R834	5	F
C260	9	H	C468	5	E	D495	10	E	R254	9	G	R449	7	D	R835	7	G
C261	10	G	C469	5	D	D800	5	H	R255	9	G	R450	7	D	R836	7	G
C262	9	J	C470	5	E	D802	2	J	R256	10	G	R451	7	D	R837	6	F
C263	9	J	C471	5	D	D803	4	I	R258	9	G	R453	2	C	R838	5	J
C264	10	I	C472	5	E	D805	6	J	R259	9	F	R454	2	C	R901	4	B
C265	10	H	C473	2	B	D806	6	I	R260	9	G	R457	2	C	R902	4	B
C401	1	E	C474	2	B	D807	6	J	R261	9	G	R458	2	C	R903	4	B
C402	1	E	C475	2	B	D808	6	J	R262	10	I	R459	2	D	R904	4	B
C403	1	E	C476	2	B	D809	6	I	R263	10	I	R460	2	E	R905	7	A
C404	1	E	C477	2	B	D810	3	I	R264	9	H	R461	3	B	R906	7	A
C405	2	E	C478	2	B	D811	3	I	R265	10	I	R462	3	B	R907	7	B
C406	2	E	C479	1	C	D812	3	H	R266	9	I	R463	6	E	R908	9	B
C407	1	D	C480	1	C	D813	3	H	R267	9	I	R464	6	E	R909	9	B
C408	1	E	C481	1	B	D814	2	I	R268	9	I	R465	5	D	R910	9	C
C409	2	D	C482	1	C	D815	2	I	R270	9	I	R466	5	E	R911	9	C
C410	2	E	C483	5	A	D816	1	I	R272	9	H	R467	5	D	R912	10	C
C411	6	C	C484	9	D	D817	1	I	R273	9	H	R468	5	E	R913	10	C
C412	6	C	C485	9	D	D818	7	J	R274	9	H	R469	5	D	R914	10	C
C413	6	C	C487	3	E	D819	7	H	R275	9	H	R470	5	E	R915	9	C
C414	5	C	C488	8	D	D820	7	H	R276	9	H	R471	6	D	R916	9	C
C415	6	C	C489	8	D	D821	7	H	R277	9	H	R472	6	D	R917	4	B
C416	5	C	C490	8	D	D822	7	H	R278	9	J	R473	7	D	R918	4	B
C417	6	C	C491	9	D	D823	8	H	R279	9	J	R474	7	D	RA401	7	C
C418	5	C	C492	7	D	D1801	7	F	R280	9	J	R475	2	A	RA801	7	F
C419	6	C	C495	10	E	IC401	8	C	R401	-2	E	R476	2	B	RA802	5	F
C420	5	C	C497	10	D	IC402	6	C	R402	2	E	R477	2	B	RA803	4	F
C421	6	B	C498	6	B	IC403	4	C	R403	2	E	R478	2	B	S801	7	I
C422	4	B	C499	8	C	IC404	3	E	R404	2	E	R479	2	A	S802	3	I
C423	5	B	C800	4	H	IC405	5	D	R405	2	D	R480	2	B	S803	2	I
C424	5	B	C801	5	H	IC406	2	A	R406	2	D	R481	2	C	S804	1	I
C425	4	B	C802	5	G	IC801	6	G	R407	2	D	R482	2	C	S805	2	H
C426	5	B	C803	4	H	IC802	7	I	R408	2	E	R483	1	C	S806	3	H
C427	5	B	C804	4	G	J401	0	E	R409	2	E	R484	1	C	S807	3	I
C428	6	B	C805	4	I	J402	1	C	R410	2	E	R485	1	B	S808	1	H
C429	4	B	C807	6	J	J891	9	B	R411	8	B	R486	3	B	S809	2	F
C430	4	C	C808	6	J	Q251	9	G	R412	8	B	R489	7	B	S810	2	G
C431	5	C	C809	2	G	Q252	9	G	R413	6	D	R490	7	B	S811	2	H
C432	5	C	C810	1	G	Q253	9	G	R414	5	D	R491	7	B	S812	1	G
C433	5	B	C811	4	H	Q254	9	G	R415	6	D	R492	7	A	S813	2	G
C434	6	B	C812	6	H	Q255	9	I	R416	5	D	R495	10	D	S814	2	F
C435	3	C	C813	6	H	Q256	9	I	R417	3	B	R496	10	D	S815	1	F
C436	3	C	C814	3	G	Q257	9	I	R418	3	C	R497	10	D	S816	1	G
C437	2	C	C891	9	A	Q259	9	H	R419	10	C	R801	3	G	S817	6	H
C438	2	C	C892	9	A	Q260	9	H	R420	9	C	R802	3	G	S818	6	H
C439	3	C	C893	10	B	Q261	9	H	R421	3	D	R804	5	I	S819	5	H
C440	3	C	CN085	8	E	Q262	10	I	R422	3	D	R806	6	I	S820	4	H
C441	3	C	CN102	2	F	Q263	9	I	R423	3	E	R807	6	I	TW402	6	D
C442	4	C	CN251	10	F	Q264	10	I	R424	3	D	R808	6	I	X1	10	H
C443	2	B	CN401	3	A	Q265	10	I	R425	10	C	R809	6	I	X2	10	H
C444	2	A	CN402	6	A	Q266	9	J	R426	10	C	R810	6	I	X4	2	F
C445	4	C	CN801	2	J	Q401	2	D	R427	10	C	R811	5	I	X401	7	C
C447	2	D	CO002	8	B	Q402	2	D	R428	4	E	R812	4	G	X5	2	H
C448	3	D	D251	9	F	Q403	2	E	R429	5	E	R813	4	G	X801	4	H
C449	3	D	D252	9	F	Q404	7	C	R430	5	D	R814	4	G			
C450	3	D	D253	9	I	Q405	5	A	R431	5	B	R815	4	G			
C451	3	D	D254	10	H	Q406	6	A	R432	6	B	R816	4	H			
C452	4	D	D255	9	J	Q407	2	C	R433	6	B	R817	4	H			
C453	4	D	D401	1	E	Q408	2	C	R434	6	B	R818	5	H			
C454	4	D	D402	1	E	Q409	6	A	R435	5	A	R819	4	I			
C455	4	D	D403	1	E	Q410	6	A	R436	6	A	R820	3	I			
C456	4	E	D404	1	D	Q411	5	A	R437	5	A	R821	3	H			
C457	4	E	D405	3	B	Q495	10	E	R438	7	C	R824	1	I			
C458	4	D	D406	7	C	Q801	2	I	R439	7	C	R825	2	I			
C459	4	D	D407	7	D	Q802	2	H	R440	7	C	R826	1	J			

■ Tuner P.C.Board (ENA-178)

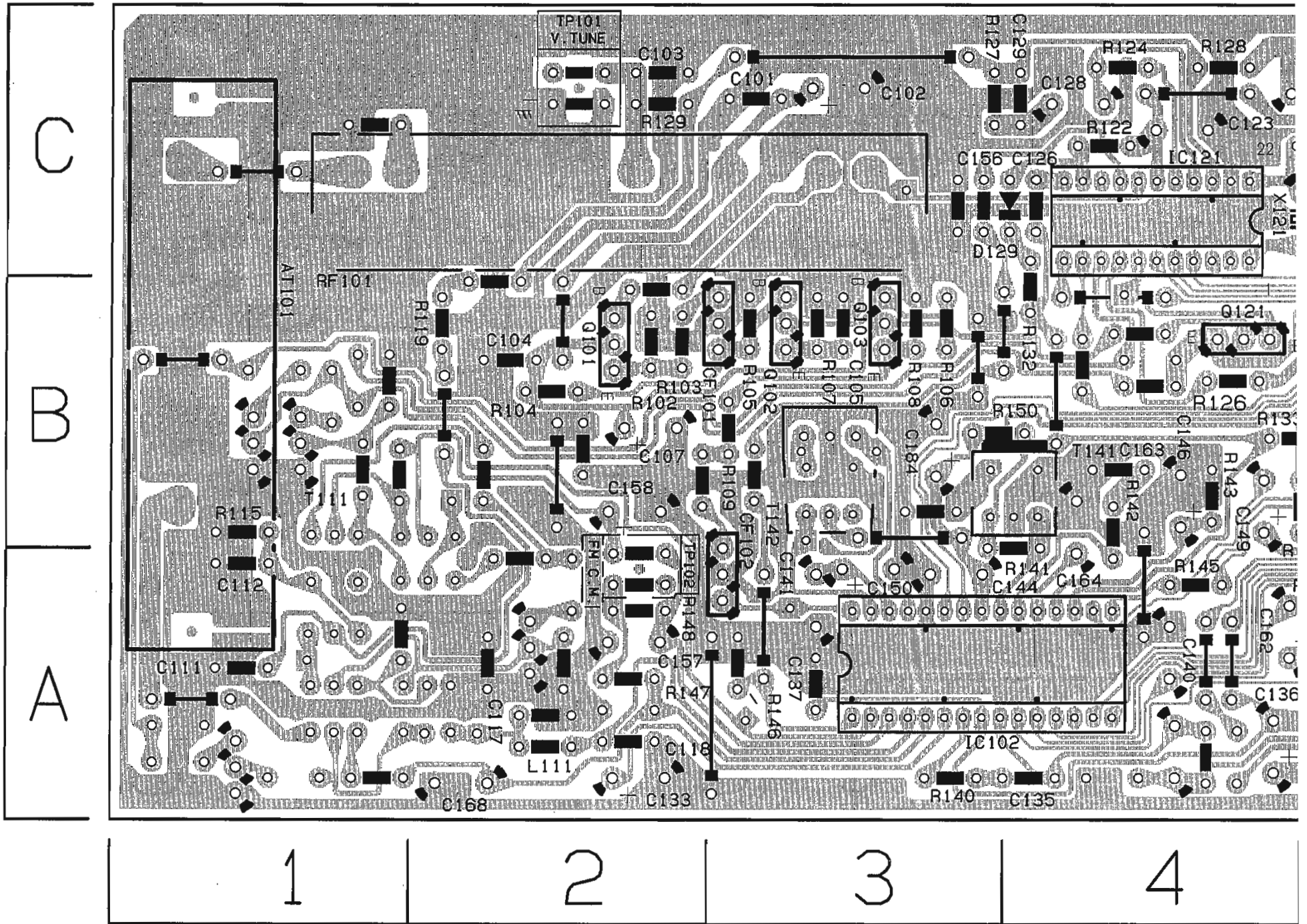

Location List (ENA-178)

Symbol	X	Y	Symbol	X	Y	Symbol	X	Y	Symbol	X	Y	Symbol	X	Y	Symbol	X	Y
C101	3	C	C130	4	C	C150	3	A	C171	7	A	C191	8	B	D131		
C102	3	C	C131	7	B	C153	5	A	C172	7	A	C192	8	C	D132		
C103	2	C	C132	7	A	C154	7	B	C173	8	A	C193	8	C	D133		
C104	2	B	C133	2	A	C155	4	A	C174	8	B	C194	8	C	FL141		
C105	3	B	C134	3	A	C156	3	C	C177	8	B	C195	7	B	FL142		
C107	2	B	C135	3	A	C157	2	A	C178	8	B	C196	8	B	IC102		
C109	5	C	C136	4	A	C158	2	B	C179	8	B	C197	7	B	IC104		
C111	1	A	C137	3	A	C159	6	B	C180	6	B	C199	8	C	IC121		
C112	1	A	C138	4	A	C160	5	B	C181	5	A	CF101	3	B	IC191		
C113	1	A	C139	5	A	C161	5	A	C182	5	A	CF102	3	A	IC192		
C117	2	A	C140	4	A	C162	4	A	C183	6	C	GN111	5	A	L111		
C118	2	A	C141	3	A	C163	4	B	C184	3	B	GN112	8	C	Q101		
C121	4	C	C143	5	B	C164	4	A	C185	6	B	D121	6	B	Q102		
C122	5	C	C144	3	A	C165	6	C	C186	5	B	D122	7	B	Q103		
C123	4	C	C146	4	B	C166	7	A	C187	7	A	D123	6	A	Q111		
C126	4	C	C147	5	B	C167	8	A	C188	8	B	D124	6	B	Q112		
C128	4	C	C148	5	B	C168	2	A	C189	8	A	D129	4	C	Q113		
C129	4	C	C149	4	B	C170	7	B	C190	8	A	D130	6	C	Q114		

XT-TD5/XT-TD55R

3. Description

Pin No.	symbol	I/O	Description	Pin No.	symbol	I/O	Description
1	BCLK	O	Not used	41	TES	O	Tracking error shunt signal output(H:shunt)
2	LRCK	O	Not used	42	PLAY	-	Not used
3	SRDATA	O	Not used	43	WVEL	-	Not used
4	DVDD1	-	Power supply (Digital)	44	ARF	I	RF signal input
5	DVSS1	-	Connected to GND	45	IREF	I	Reference current input pin
6	TX	O	Digital audio interface output	46	DRF	I	Bias pin for DSL
7	MCLK	I	μ com command clock signal input (Data is latched at signal's rising point)	47	DSLIF	I/O	Loop filter pin for DSL
8	MDATA	I	μ com command data input	48	PLLIF	I/O	Loop filter pin for PLL
9	MLD	I	μ com command load signal input	49	VCOF	-	Not used
10	SENSE	O	Sence signal output	50	AVDD2	-	Power supply(Analog)
11	FLOCK	O	Focus clock signal output Active Low	51	AVSS2	-	Connected to GND(Analog)

■ BA6897FP(IC641) 4channel driver

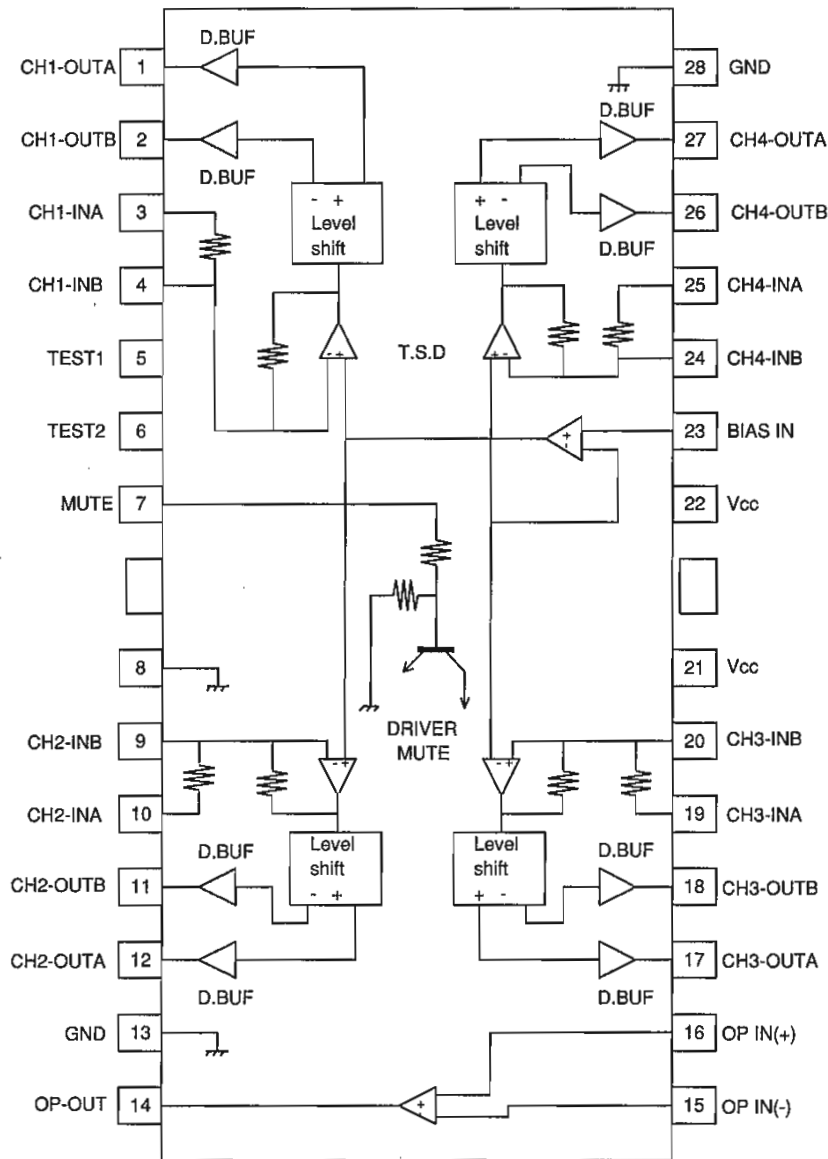

■ HA12136(IC561)

Noise Reduction Amplifier

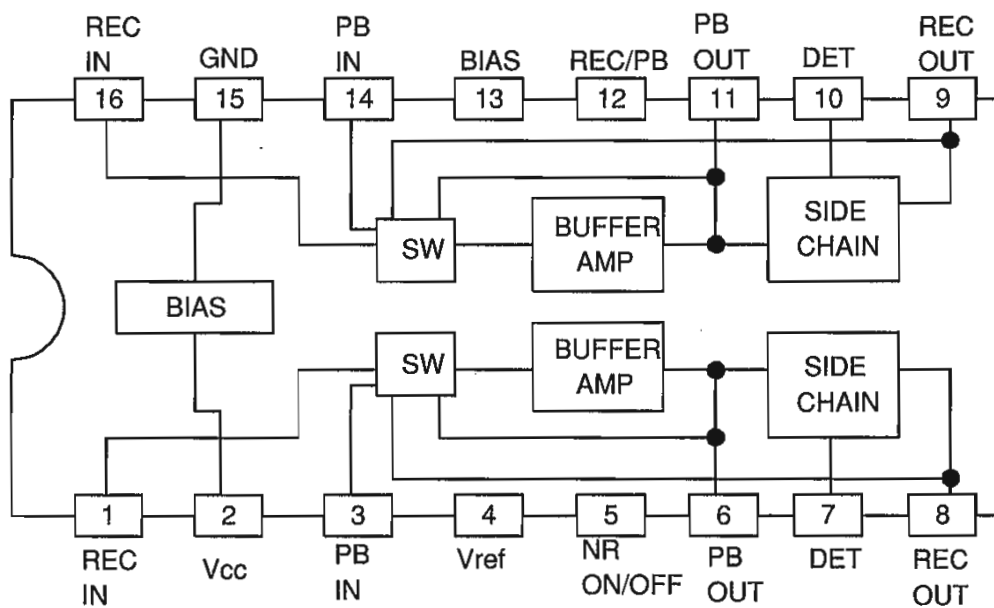

■ LB1641(IC775,IC691,IC692) DC Motor Driver

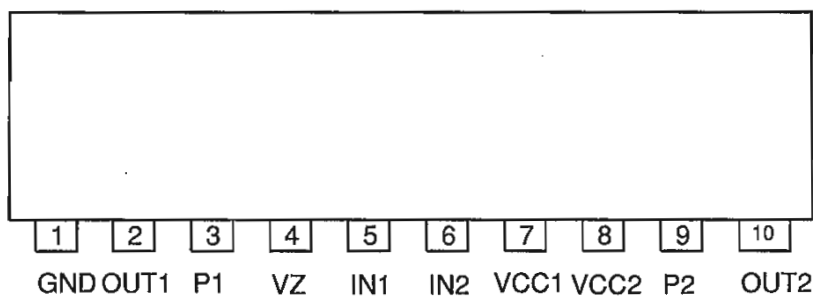

FUNCTION

Input		Output		Mode
IN1	IN2	OUT1	OUT2	
0	0	0	0	Brake
1	0	1	0	CLOCKWISE
0	1	0	1	COUNTER-CLOCKWISE
1	1	0	0	Brake

XT-TD5/XT-TD55R

■ TC4052BP(IC731) : Multiplexer

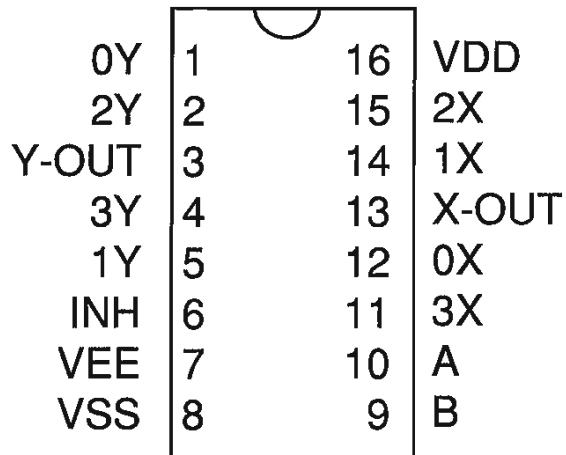

INHIBIT	B	A	X-OUT	Y-OUT
L	L	L	0X	0X
L	L	H	1X	1X
L	H	L	2X	2X
L	H	H	3X	3X
L	L	L	-	-
L	L	H	-	-
L	H	L	-	-
L	H	H	-	-
H	*	*	NONE	NONE

■ MN1381(IC752) : Reset IC

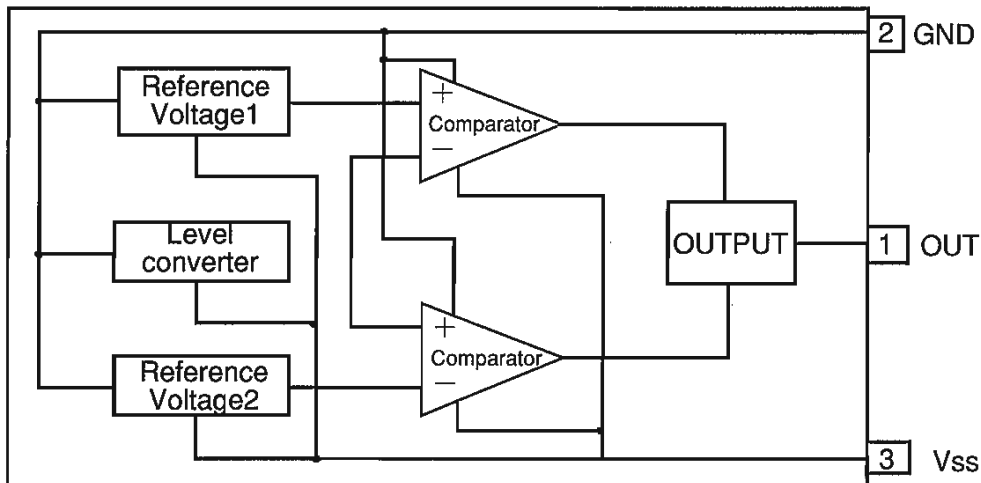

Pin No	symbol	Function
1	OUT	Reset signal output Reset : L
2	Vdd	Power supply
3	Vss	GND

Main parts Layout

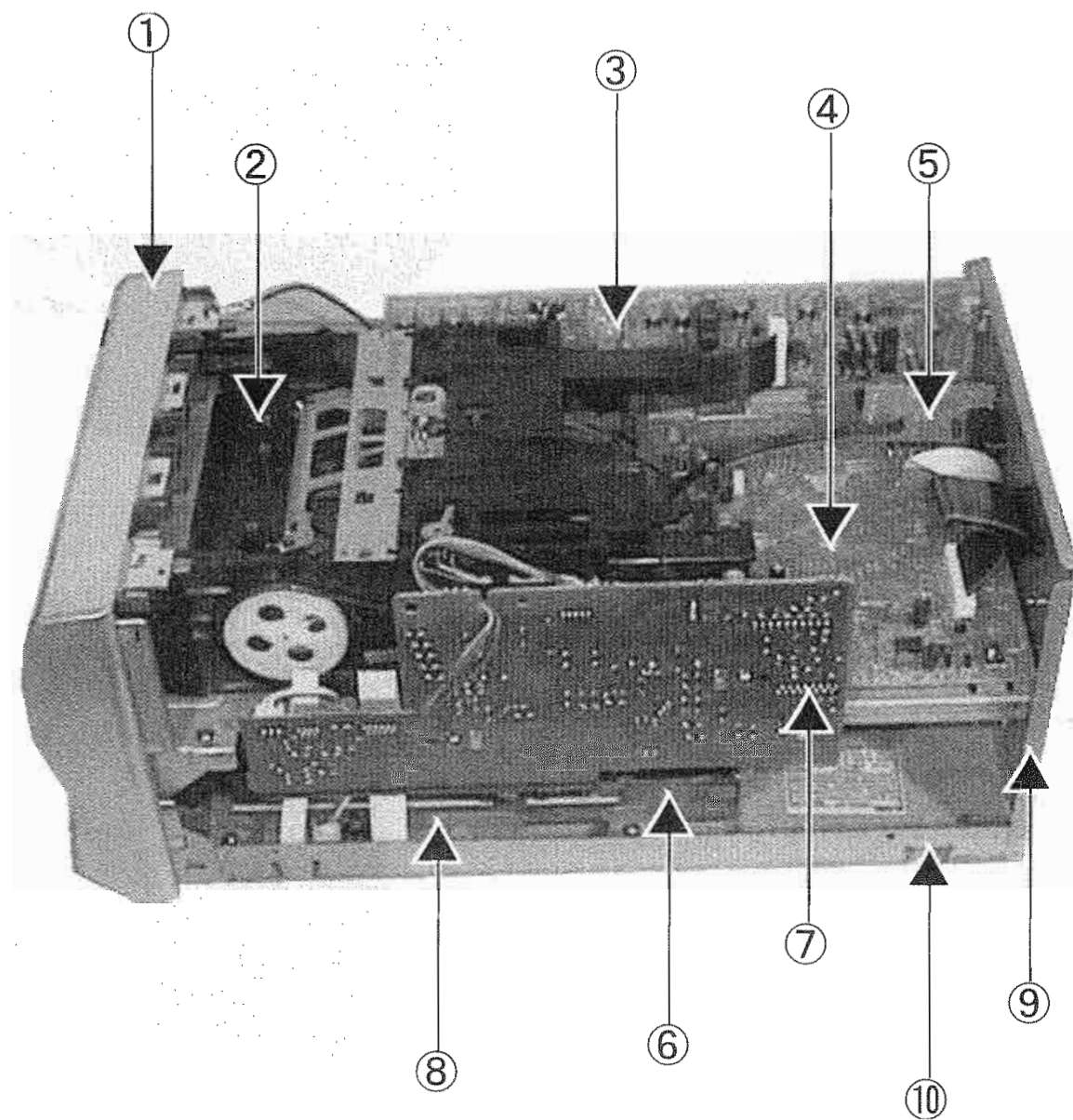

XT-TD5 Inside View

- ① Front Panel
- ② Cassette mech. ass'y
- ③ Deck PCB
- ④ Deck/CD control
- ⑤ Optical out PCB
- ⑥ CD changer mech. ass'y
- ⑦ Deck loading mech. PCB
- ⑧ CD servo PCB
- ⑨ Rear panel
- ⑩ Bottom Base

Disassembly Procedures

(1) Removing the top cover

- 1.Remove 2 screws(A)fastening both sides of top cover,and 4 screws(B) fastening the rear side.
- 2.Remove the top cover.

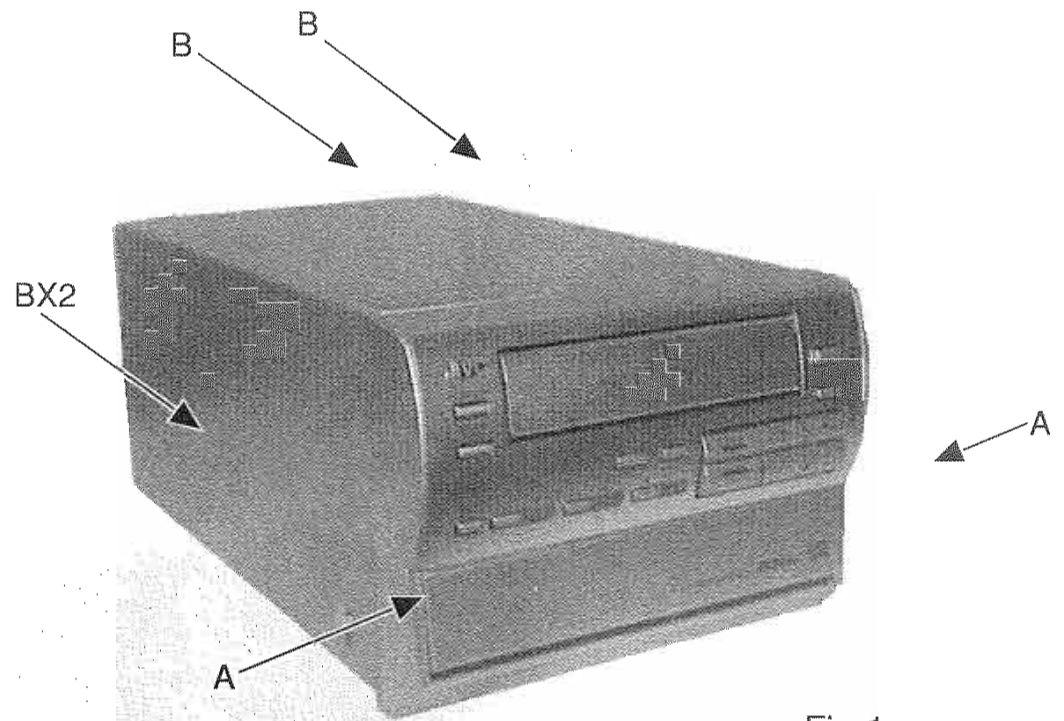

Fig.1

(2) Removing the Rear panel

- 1.Remove 6 screws(C)fastening rear panel(Fig.2).
- 2.Disconnect the Flat wire from the CN701.
- 3.Remove the Rear panel from the Hook of Bottom base.

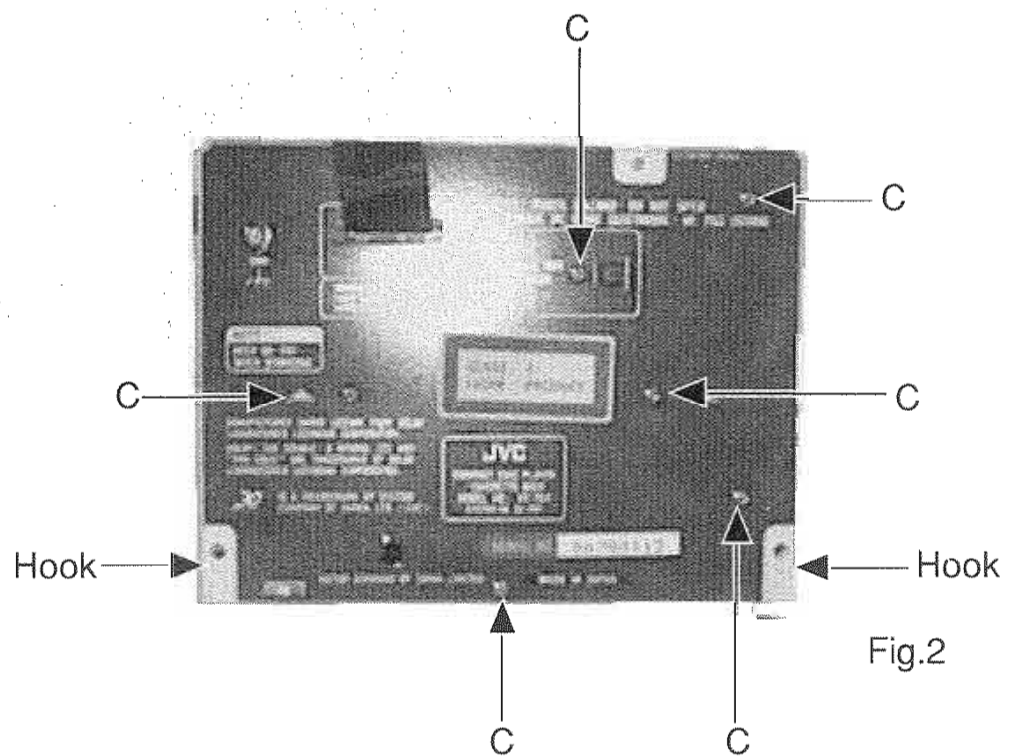

Fig.2

(3) Removing the Cassette Deck mech. ass'y.

- 1.Rotate the Pulley (D) clockwise with finger so that Cassette tray is unlading .
- 2.Take out the tray hitting.
- 3.Disconnect the CN791.
- 4.Remove the 2 screws (E) and Remove the Cassette Deck mech.ass'y.

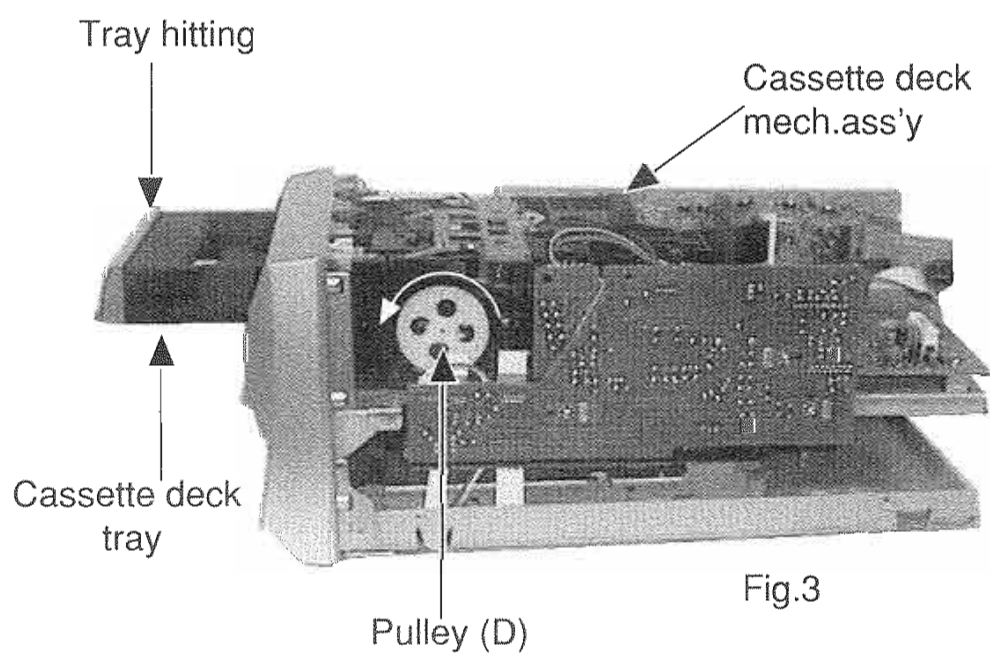

Fig.3

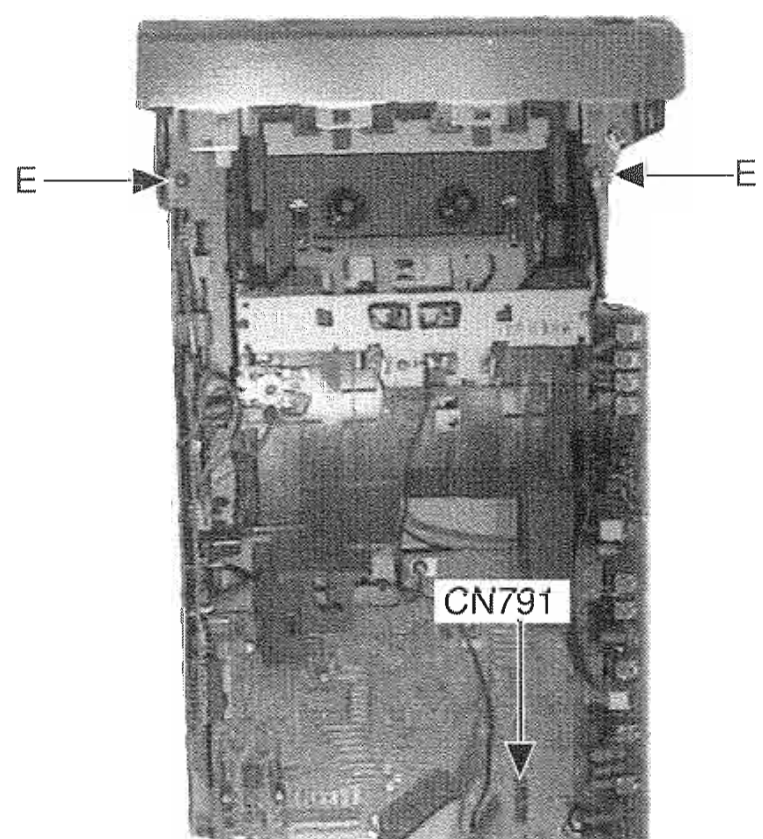

Fig.4

(4) Removing the CD changer mech. Ass'y

1. Remove the cassette mech. ass'y.
2. Remove 4 screws (F) fastening the CD changer mech. ass'y (Fig.5).
3. Push the Rack gear so that CD tray is open (Fig.6).
4. Remove the CD tray hitting (Fig.7).
5. Remove the CD changer mech. ass'y.

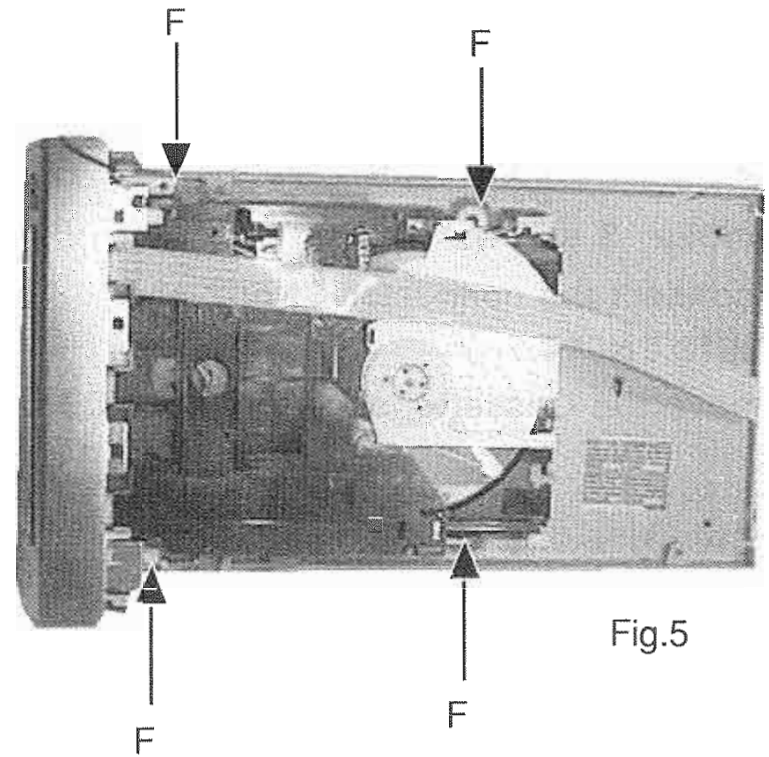

Fig.5

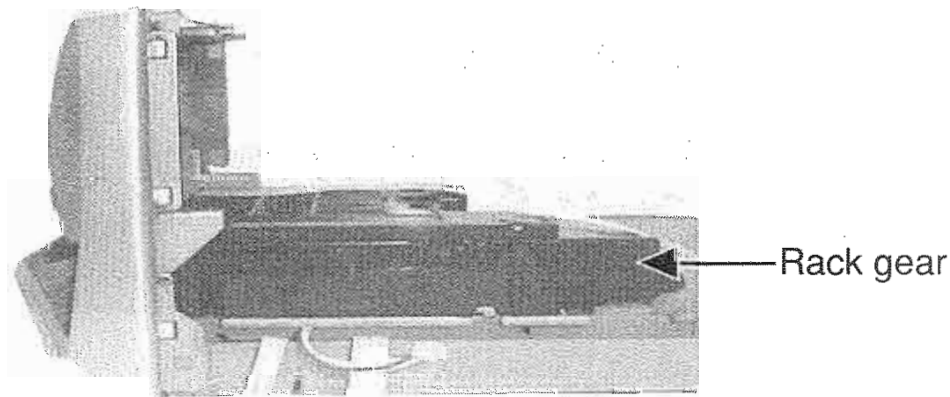

Fig.6

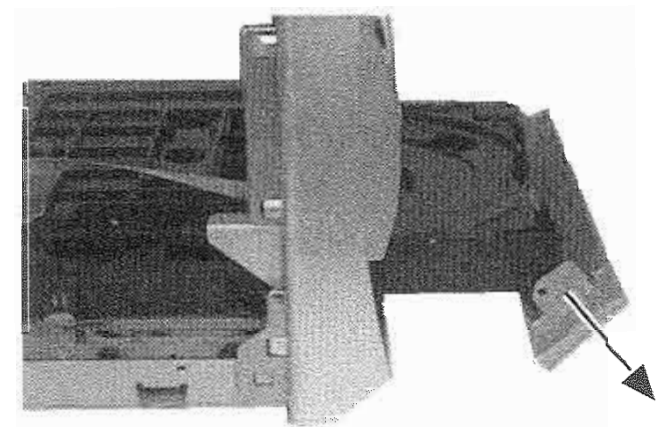

Fig.7

(5) Removing the Front panel Ass'y

1. Remove the Top cover.
2. Remove the Cassette tray hitting and CD changer tray hitting.
3. Disconnect the flat wire from CN791.
5. Remove the 2 screws (G) (Fig.8).
6. Release the 2 hooks holding the Front panel ass'y and Remove it.

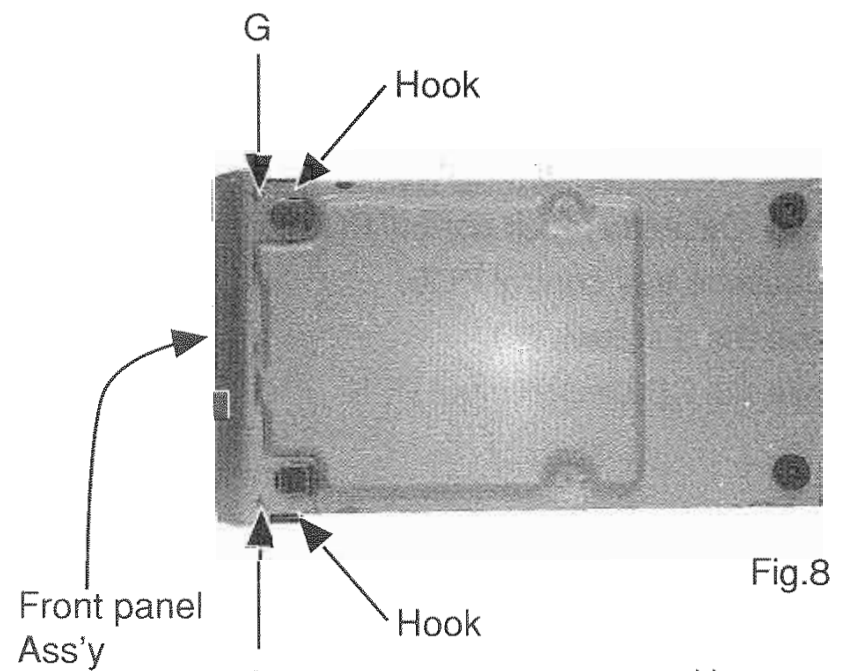

Fig.8

(6) Removing the Front PCB

1. Remove the Front panel ass'y.
2. Remove the 6 screws (H) fastening the Bracket and Front PCB.
3. Remove the Front PCB.

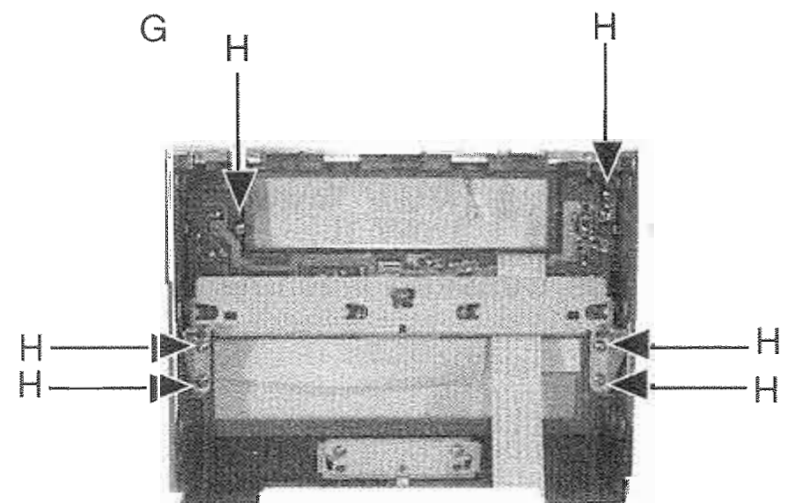

Fig.9

Cassette Mech. Ass'y removal

(7) Removing Cassette mech. control PCB

- 1.Remove 3 screws (I).
- 2.Disconnect the connector CN502 and CN513,CN514
- 3.Remove the Cassette mech. control PCB.

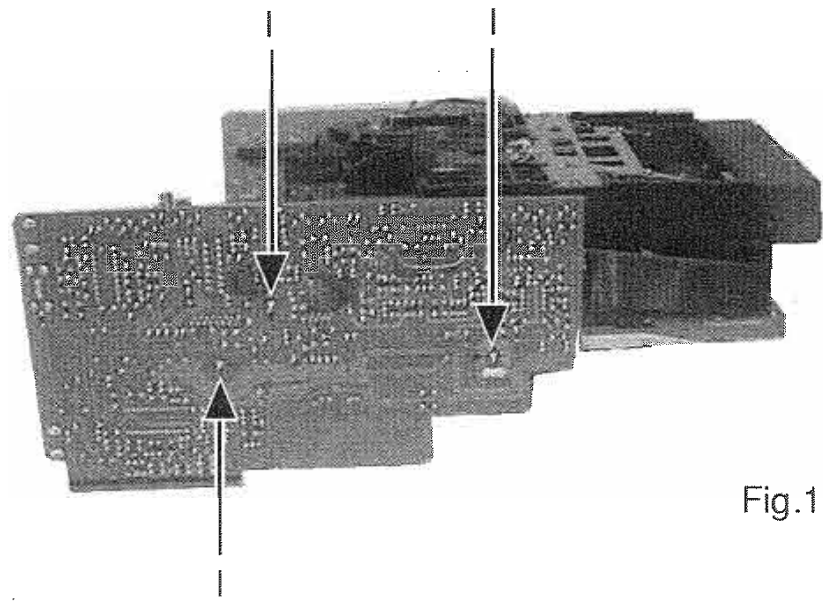

Fig.10

(8) Removing Cassette Tray control PCB

- 1.Remove 3 screws (J) .
- 2.Disconnect the connector CN702 and CN703.
- 3.Remove the Cassette Tray control PCB.

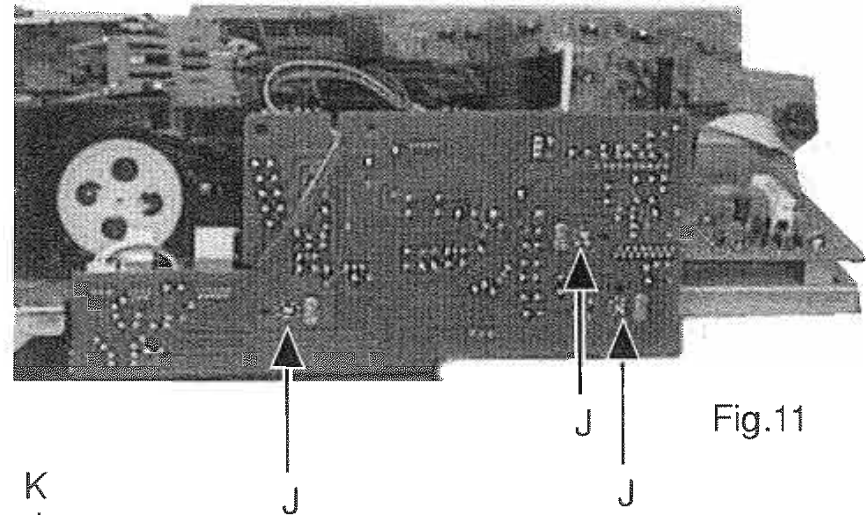

Fig.11

(9) Removing CD/Deck control PCB

- 1.Remove the Cassette mech. Ass'y .
- 2.Remove Cassette mech.control PCB and Cassette tray control PCB.
- 3.Remove the 3 screws (K).
- 4.Remove the CD/Deck control PCB.

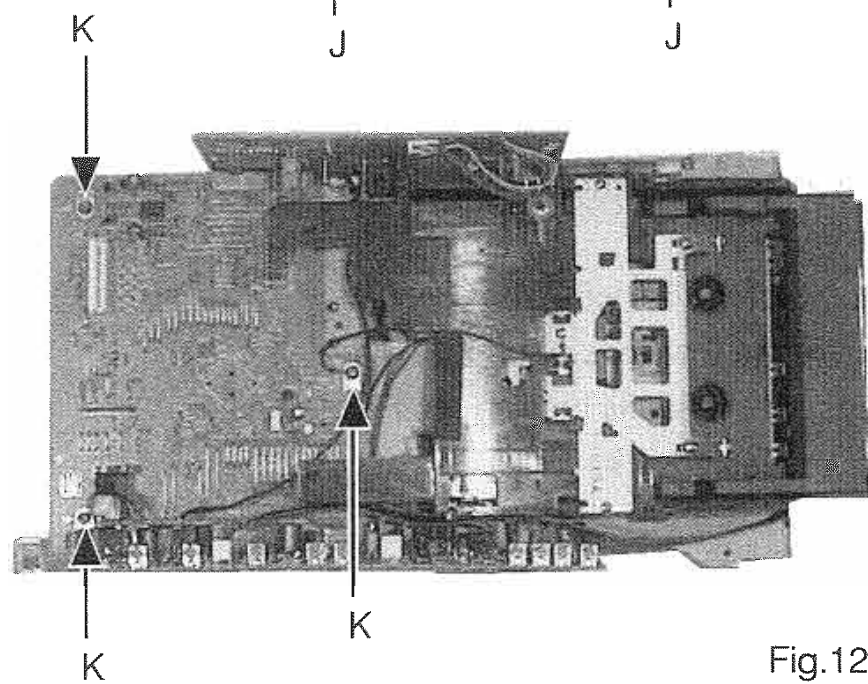

Fig.12

(10) Removing Cassette mech. Ass'y (with out control PCB)

- 1.Remove the (7),(8),(9).
- 2.Remove the 4 screws (L).
- 3.Remove the Cassette mech.Ass'y.

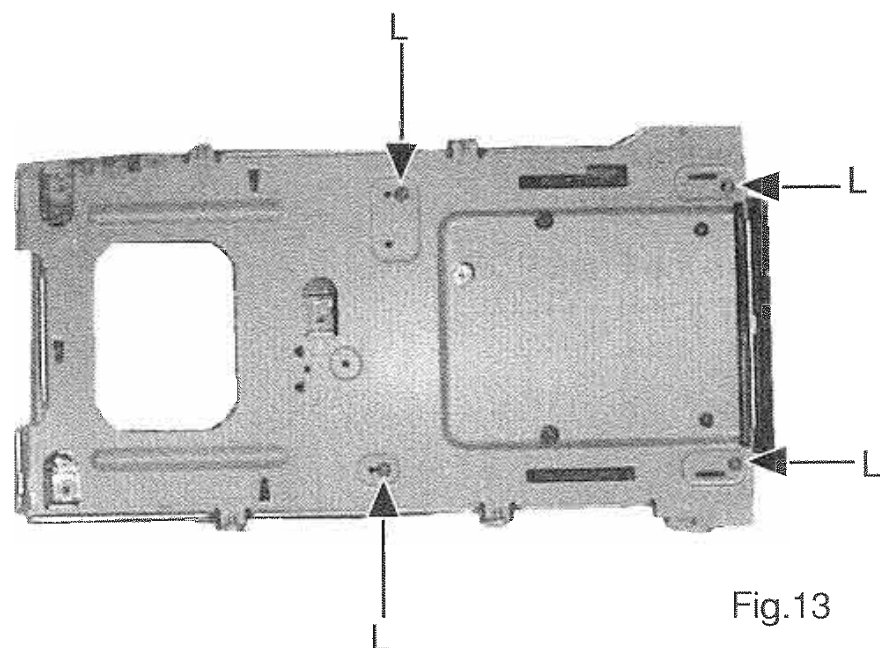

Fig.13

(11) Removing Cassette Tray

- 1.Remove the Cassette mech. Ass'y .
- 2.Remove 2 screws (M).
- 3.Release the spring from the plate,and Remove a plate.
- 4.Push the hook shown in the figure Fig.14,and Remove the Cassette holder.
- 5.Rotate the loading pulley counterclock wise ,and open the Cassette tray.(Fig.15)
- 6.Push the Cassette tray hooks of both side shown in the figure Fig.15 .
- 7.Pull out the Cassette tray.

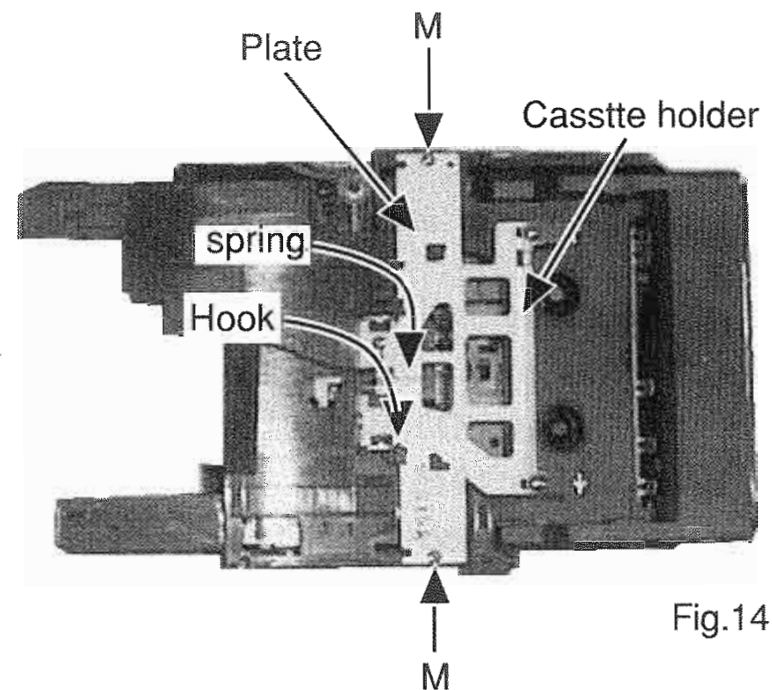

Fig.14

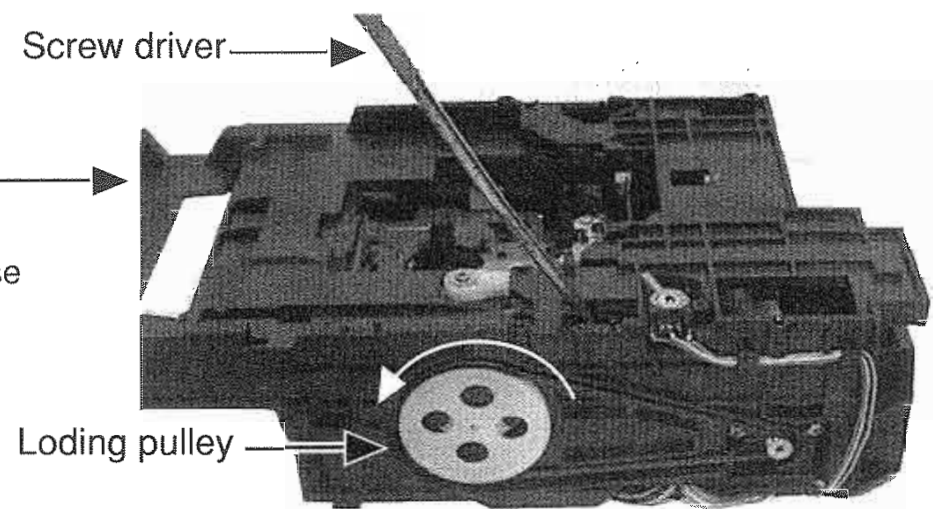
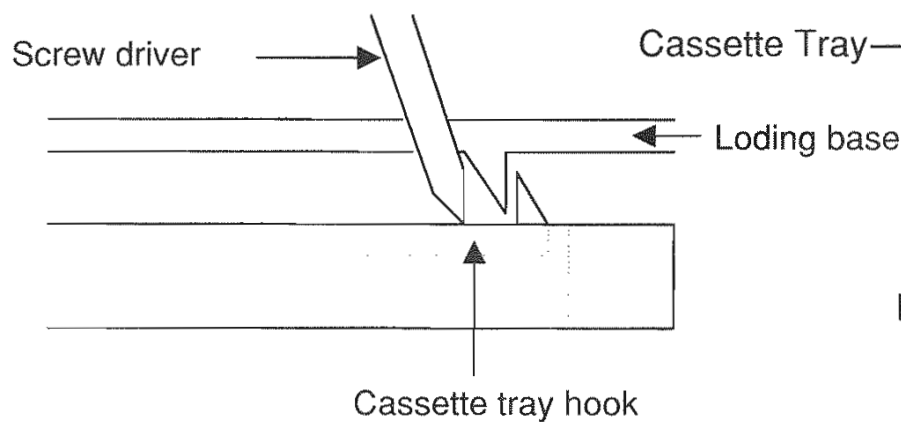

Fig.15

**(12) Removing Cassette Mech. Ass'y
(with out loading mech.ass'y)**

- 1.Remove the Cassette mech. Ass'y.
- 2.Remove 6 screws (N).
- 3.Remove the Cassette mech.ass'y.

œ Procedures for Reassembling the Cassette mech. Ass'y.

- 1.Open the Cassete Tray.
- 2.Mounting the Cassette mech.Ass'y.

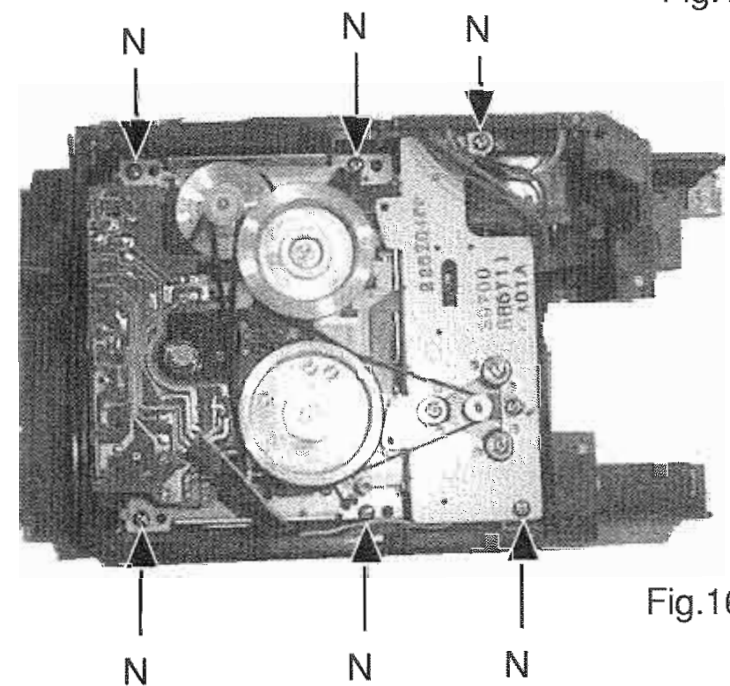

Fig.16

(13) Removing the Cassette mech. Switch PCB

- 1.Remove the Cassette mech. Ass'y .
- 2.Unsolder the 4 pin wire and solenoid terminal.
- 3.Remove the 2 screws (O).
- 4.Remove the Cassette mech. PCB.

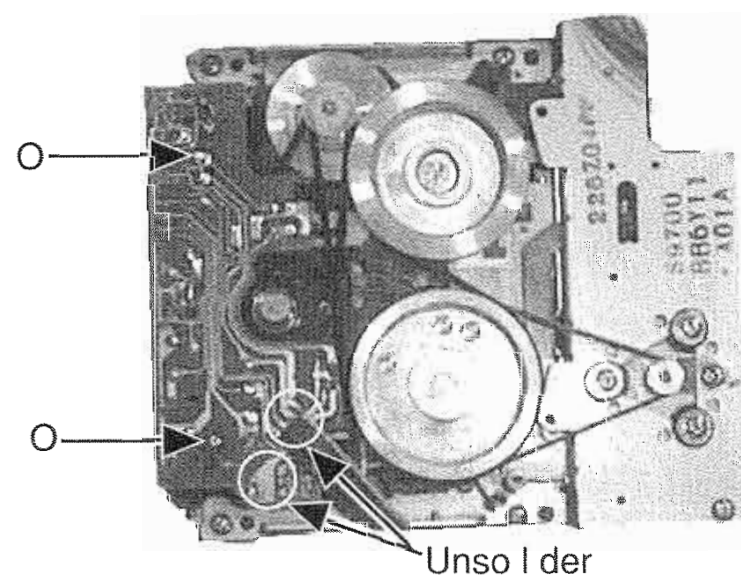

Fig.17

XT-TD5/XT-TD55R

(14) Removing the Head

- 1.Remove the Cassette mech. Ass'y.
- 2.Remove 2 screws 'P'.
- 3.Unsolder the 4 pin wire.

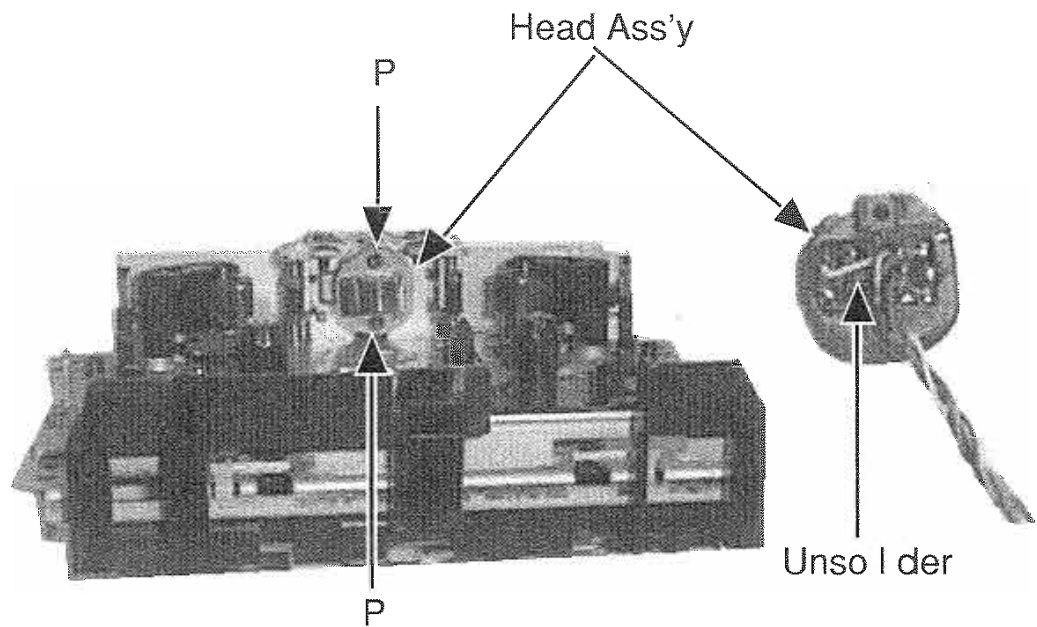

Fig.18

(15) Removing the Head ass'y

- 1.Remove the Cassette mech. Ass'y.
- 2.Remove the 2screws 'O' holding the motor bracket(Fig.19a).
- 3.Remove the nylon washer (Fig19b).
- 4.Remove the Rotation Gear .
- 5.Remove the Head ass'y with wire ass'y.

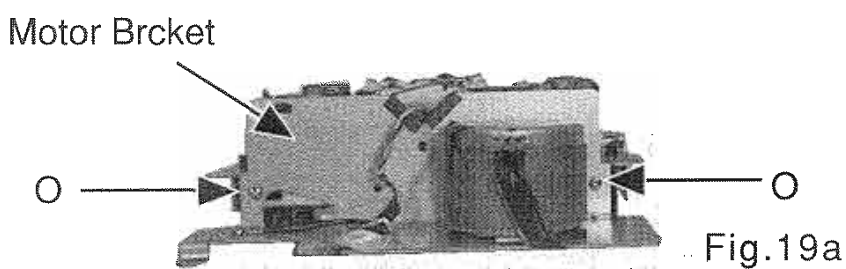

Fig.19a

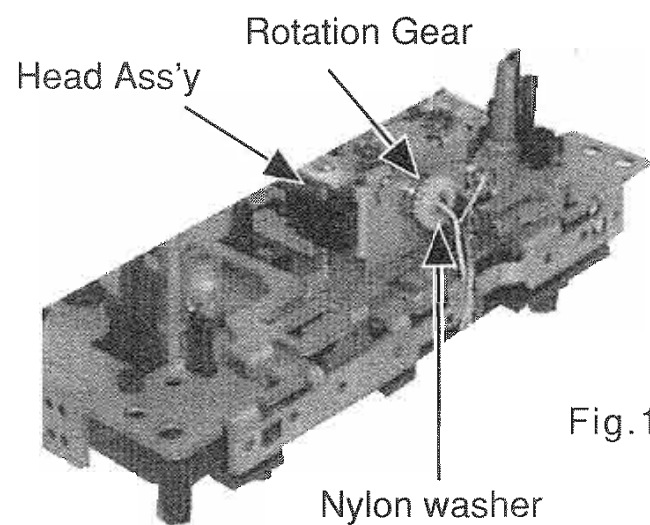

Fig.19b

(16) How to assemble the Head ass'y

- 1.Set the Forward playing position of the return gear and Rotation gear .
- 2.Attach the Nylon washer.

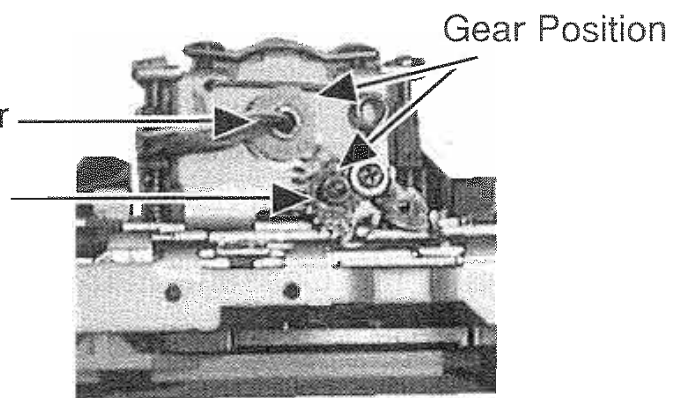
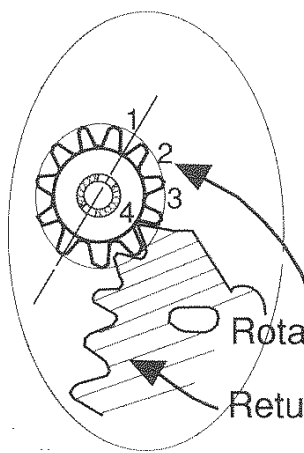

Fig.20

(17) Removing the Head ass'y

- 1.Remove the screw 'Q' holding the cassette guide.
- 2.Remove the Head chassis ass'y.

(18) How to assemble the Head chassis ass'y

- 1.Set the play arm position shown in the figure below(Fig.21).
- 2.Attach the Head chassis ass'y and chassis base.

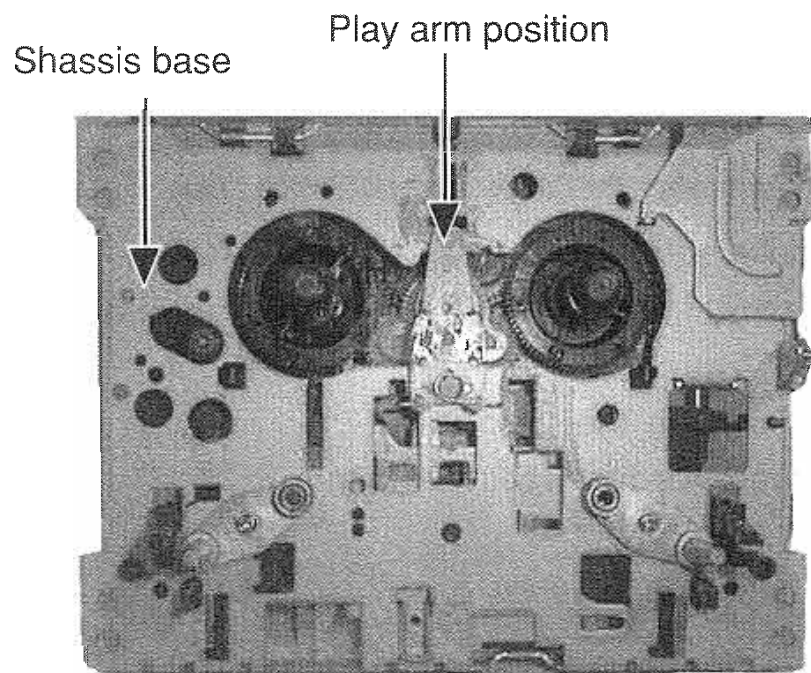
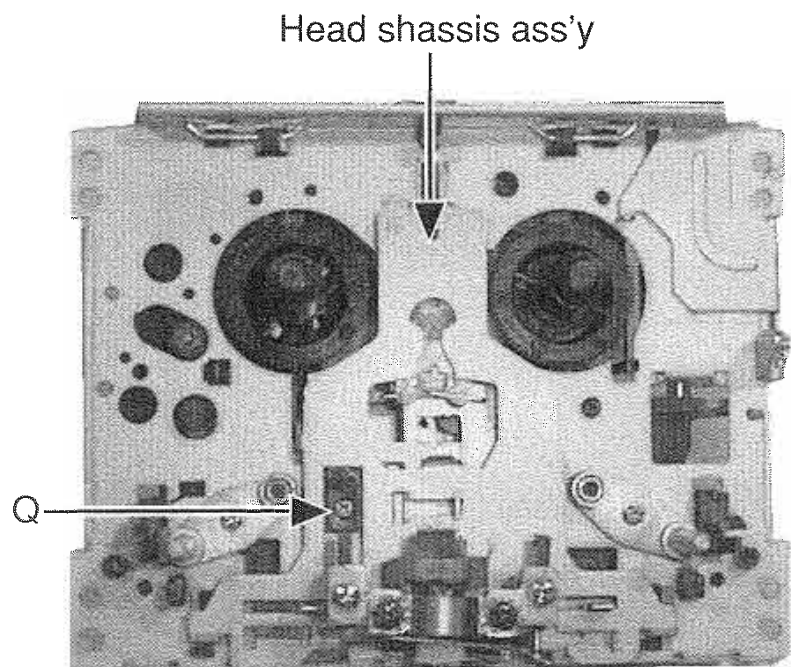

Fig.21

(19) Removing the Pinch roller

- 1.Remove the Deck mech. Ass'y.
- 2.Release the hook holding the Pinch roller.

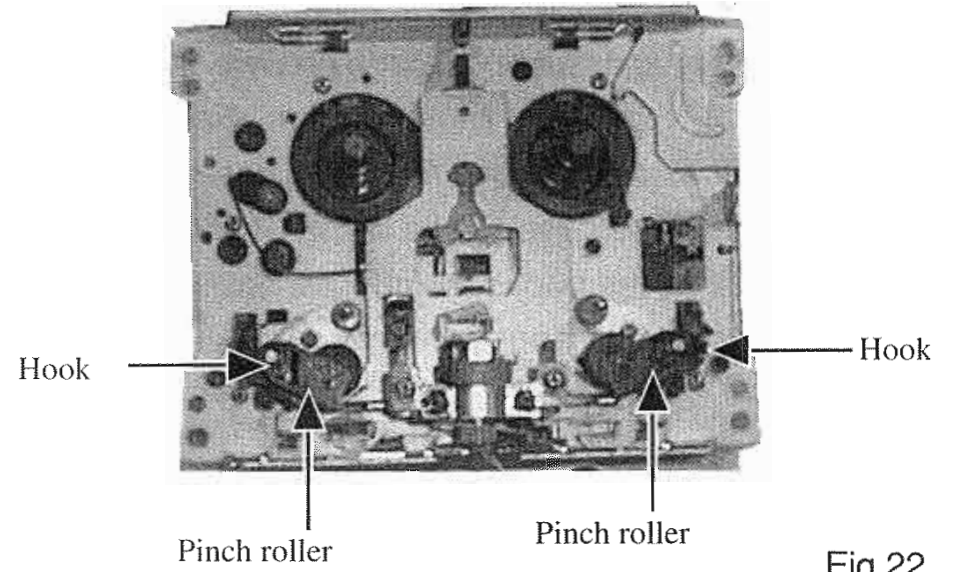
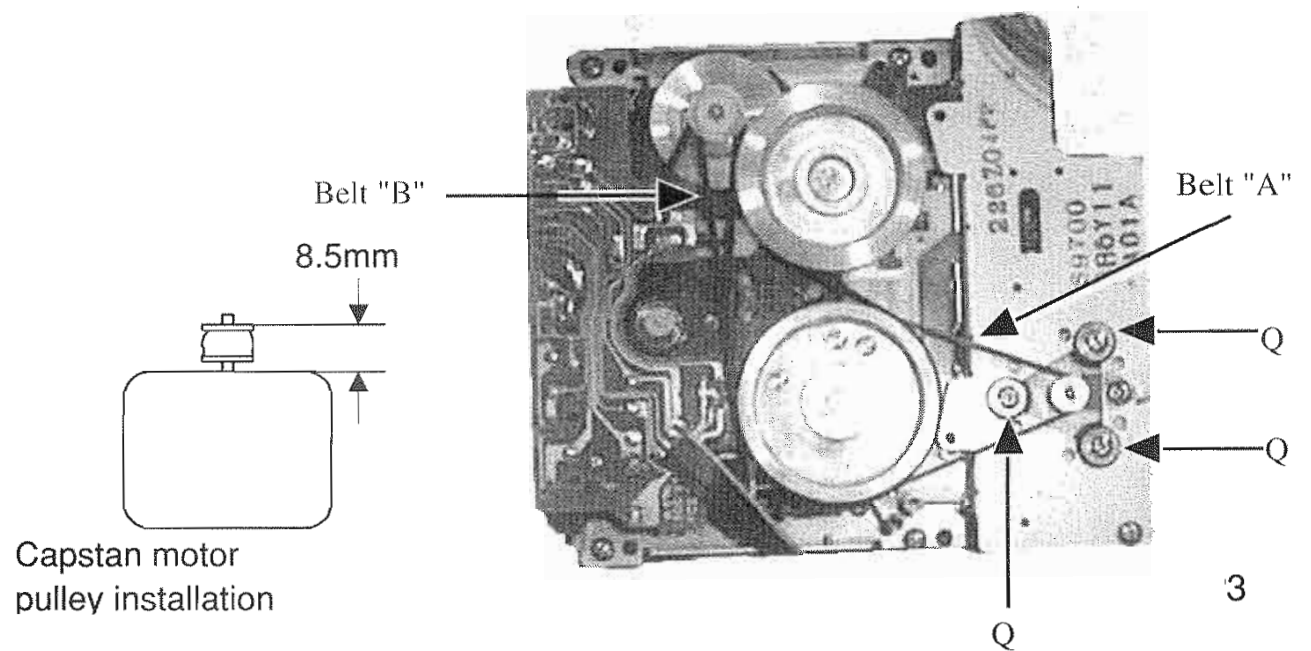

Fig.22

(20) Removing the Capstan motor

- 1.Remove the Deck mech. Ass'y.
- 2.Remove the Belt "A".
- 3.Remove the 3 screws (Q).
- 4.Unsolder the 4 pin wire of the Capstan motor terminal.
- 5.Remove the Capstan motor.



3

(21) Removing the Flywheel

- 1.Remove the Deck mech. Ass'y.
- 2.Remove the Belt "B".
- 2.Remove the Nylon washer holding the Flywheel shaft.
- 3.Remove the Flywheel.

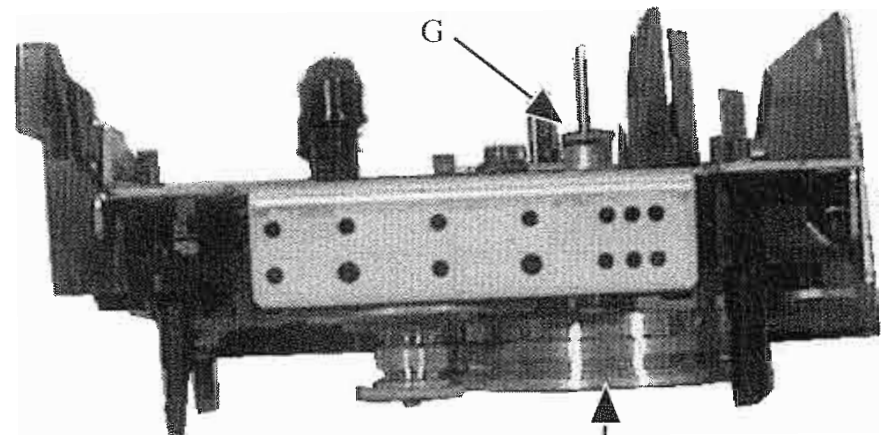

Fig.24

(22) Removing the Mech.Base

- 1.Remove the Deck mech. Ass'y.
- 2.Remove Capstan motor bracket and mech.switch PCB .
- 3.Remove the 4 screws (R).
- 4.Release the 4 Hooks holding the Control cam Ass'y.
- 5.Remove the Mech. Base.

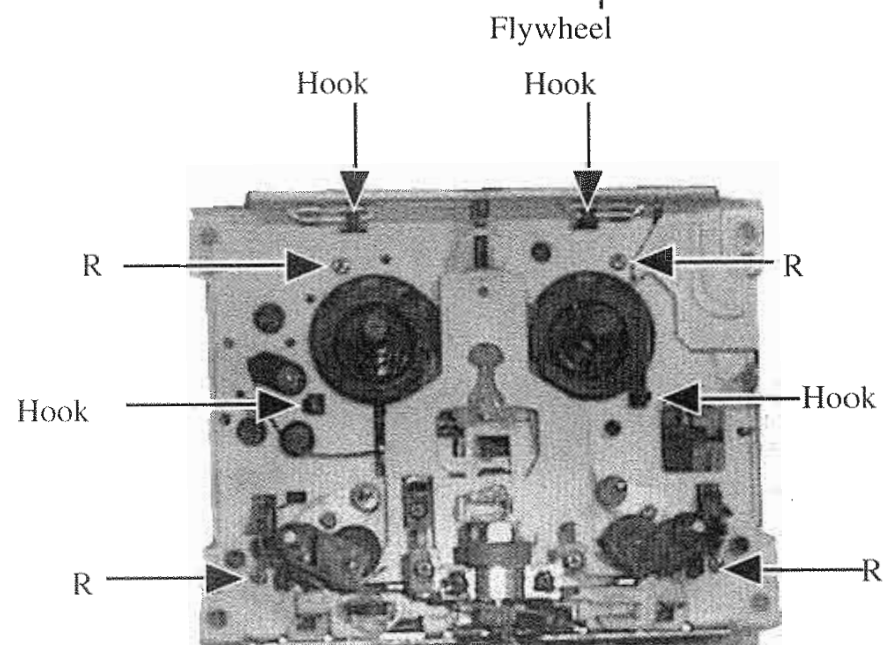
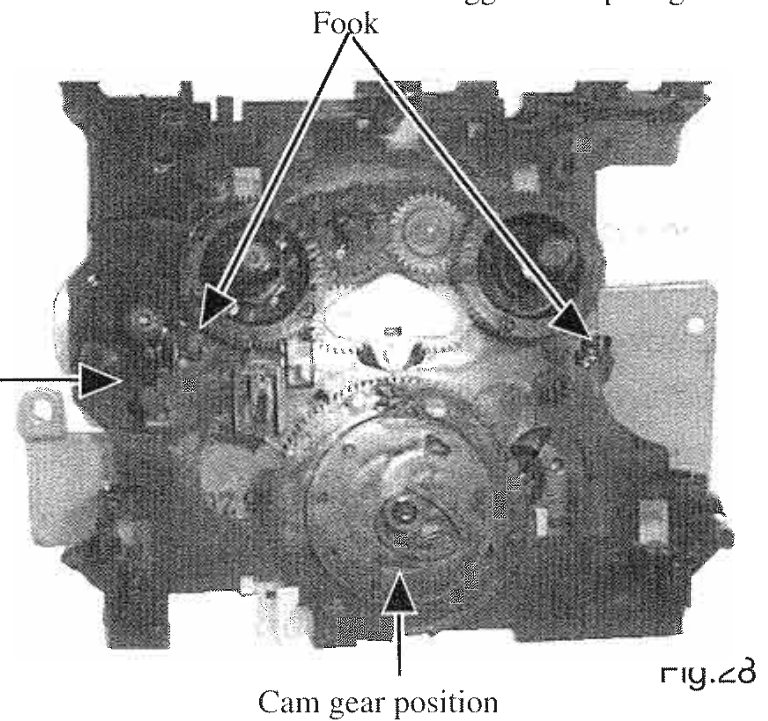
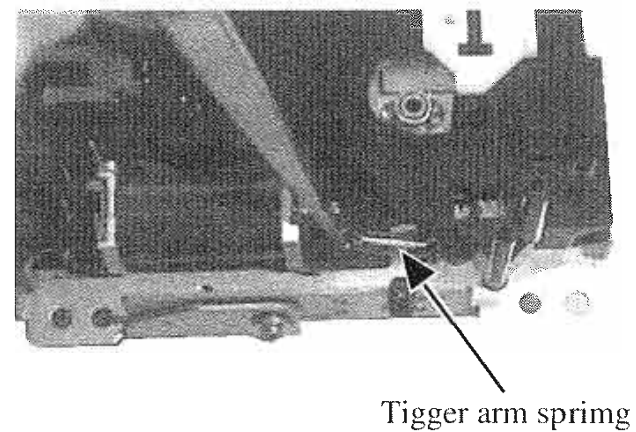
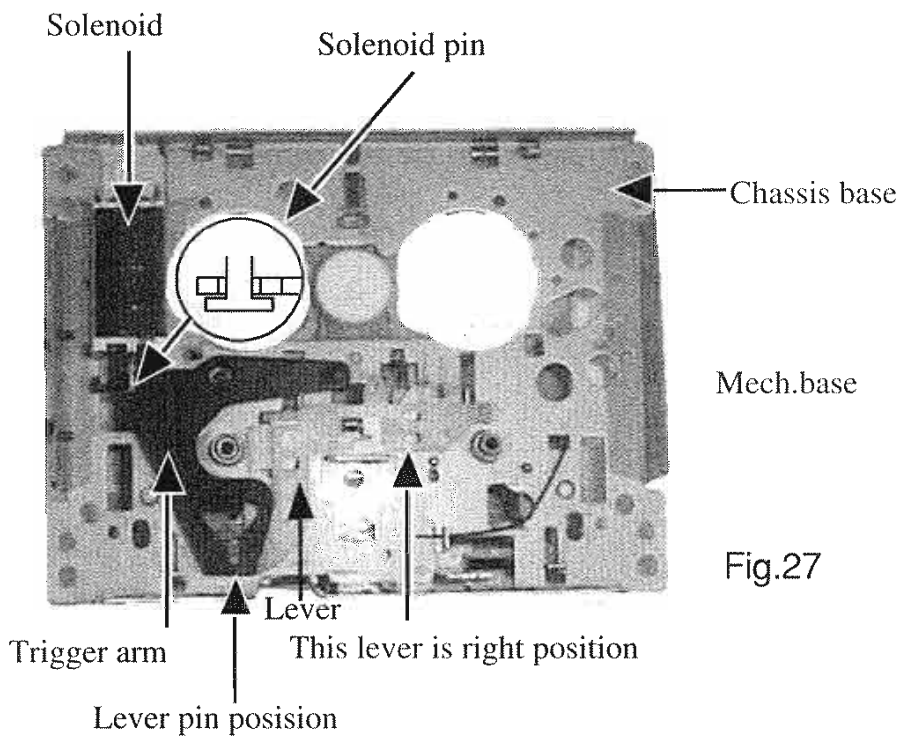

Fig.25

XT-TD5/XT-TD55R

(23) How to assemble the Chassis base and Mech. base

1. Set the Levers and Gear position as shown in the figure below. (Fig.27, Fig.28) (Head position : Forward)
2. Unite the Chassis base and the Mech. base into one.
3. Be hook the Mech. base Fooks to the Chassis base.
(When installing the hooks, the chassis base pull up little.)
4. Be hook the Trigger arm spring.



(24) How to install the belts

1. Install the flywheels and belts as shown in the figure below. (Fig.29, Fig.30)

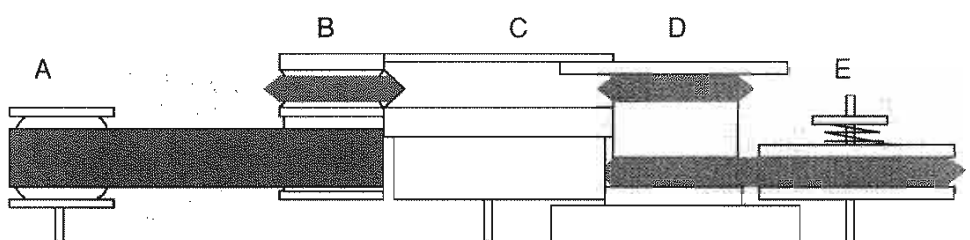
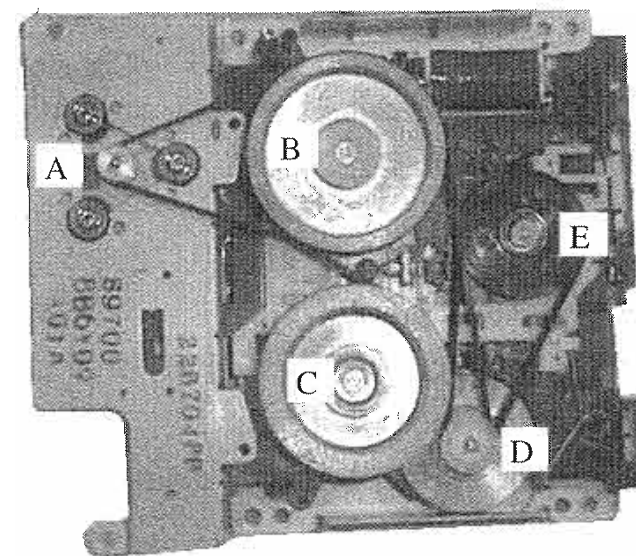

Fig.29



(25) Deassemble the Tray Ass'y

1. Remove the Cassette Tray .
2. Remove the screw 'R' and remove the Rock Arm.
3. Slide the Bracket for rear side.
4. Remove the Tray 'B' ass'y from the Tray 'A' ass'y.

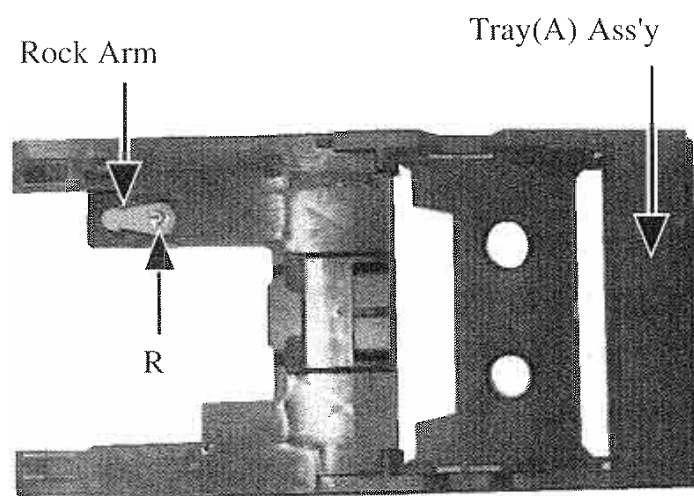
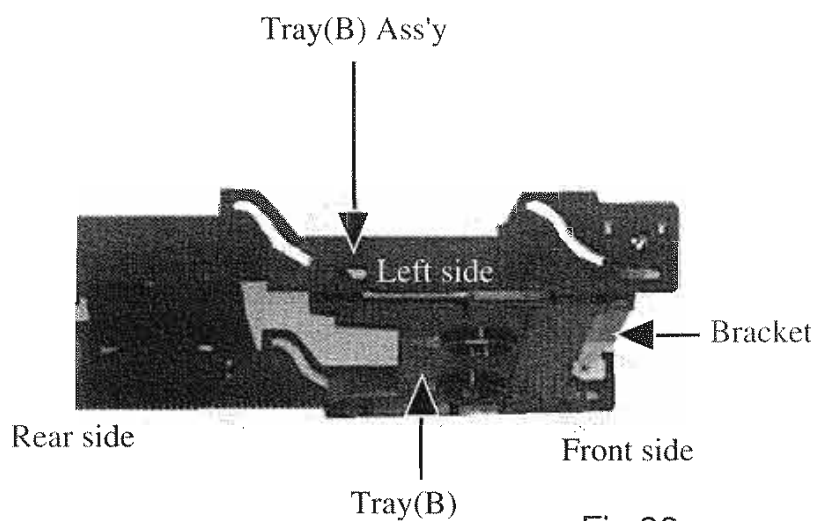

Fig.31

(26) How to assemble the Tray Ass'y

1. Slide the Tray(B) for front side (Fig.32).
2. Unite the Tray 'A' ass'y and Tray 'B' ass'y.

CD Driver Mechanism Section

■ Removing the CD Mechanism Section

1. Remove the CD traverse mechanism assembly from the body.

Caution 1: Prior to removing CD traverse mechanism assembly, be sure to set all of the sub-trays to the [STOP] mode.

Caution 2: In the case of removing the mechanism when this system has been set to the [PLAY] mode, the slide cam L on the left side of the CD traverse mechanism should be moved in the arrow A direction and positioned to A. Under this condition, the CD traverse mechanism will be lowered to the position as shown in Fig.1).

2. Remove the four screws 1 retaining the top cover (See Fig.2).

3. After pulling out the rod from the clamper, remove it together with the top cover (See Figs.2 and 2a).

4. Pull out the CD tray.

5. Remove the one screw 2 retaining the clamper (See Fig.3).

6. After moving the clamper in the arrow B direction and shifting it in the arrow C direction, take it out from the engagement section B (See Fig.3).

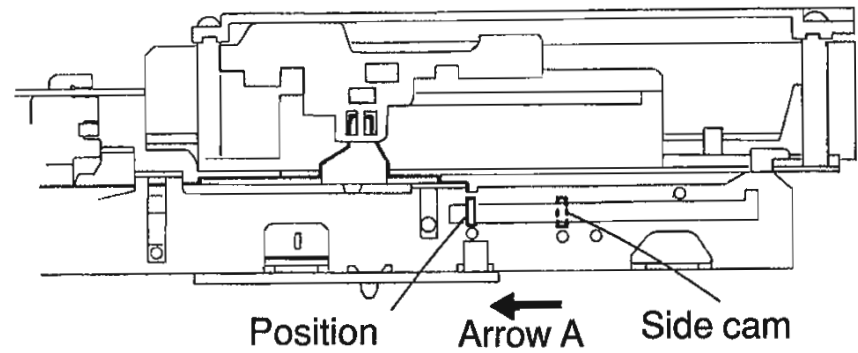

Fig.1

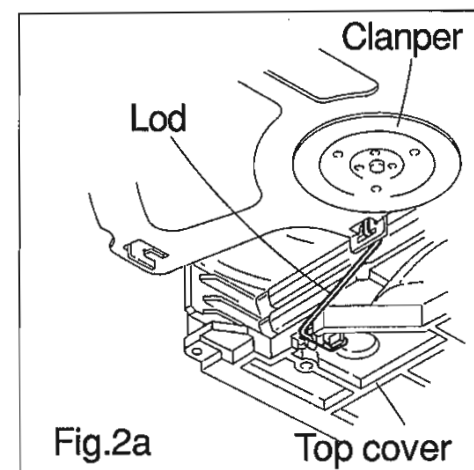
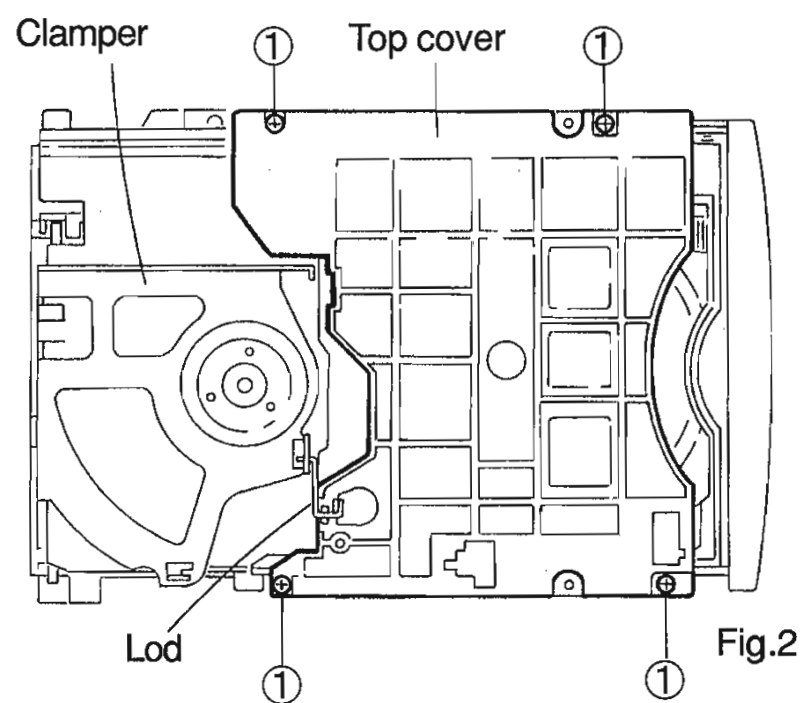

Fig.2a

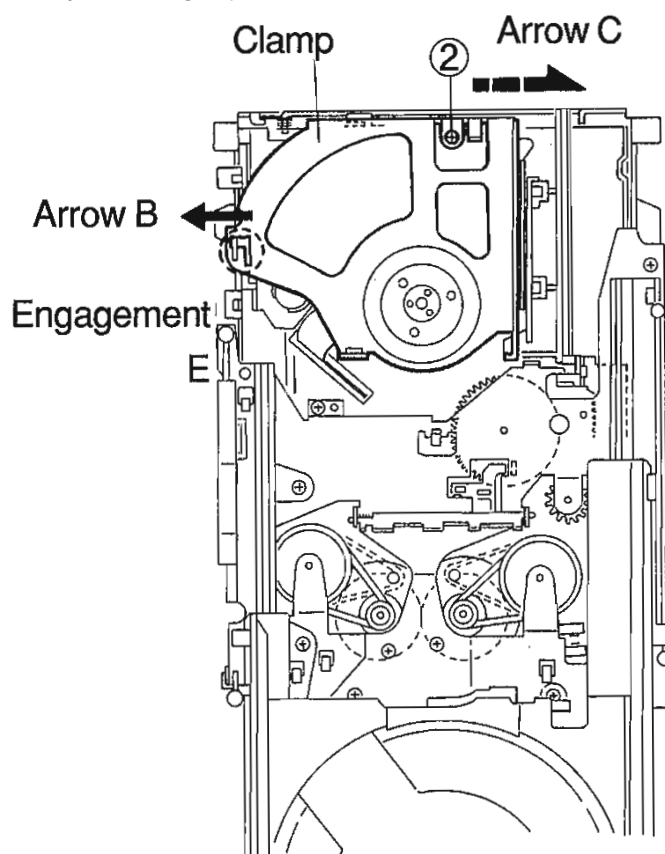

Fig.3

XT-TD5/XT-TD55R

7. Move the center pawl in the arrow D direction and remove the stopper fixing the CD mechanism as shown in Fig.4
8. Remove and take out the three insulators from the CD mechanism by using tweezers and so forth (See Fig.4).
9. By soldering, fill the position (in Fig.5) of the flexible P.C. board outgoing from the CD mechanism.
10. From the connector CN601 on the CD traverse mechanism control & servo P.C. board, remove the flexible P.C. board (See Fig.5).

caution: Since it will be hard to remove the flexible P.C. board from the connector CN601 use pliers after covering with cloth, etc. so as not to cause any damage to the P.C. board and connector.

- Procedures for Reassembling the CD Mechanism
 - In principle, reassemble the CD mechanism according to the opposite orders of the removing steps. Meanwhile, be sure to remove any filed position by soldering in "Removing Step 9" above.
 - After aligning the engagements 『B』 and 『C』 at the position where the CD mechanism has been lowered as described in "Removing Steps 6 and 7", be sure to mount the mechanism straight and fix the mechanism with screws.
 - After aligning the slide cam R as shown in Fig.6 (See "Removing Step 2"), mount the top cover and fix the mechanism with screws.

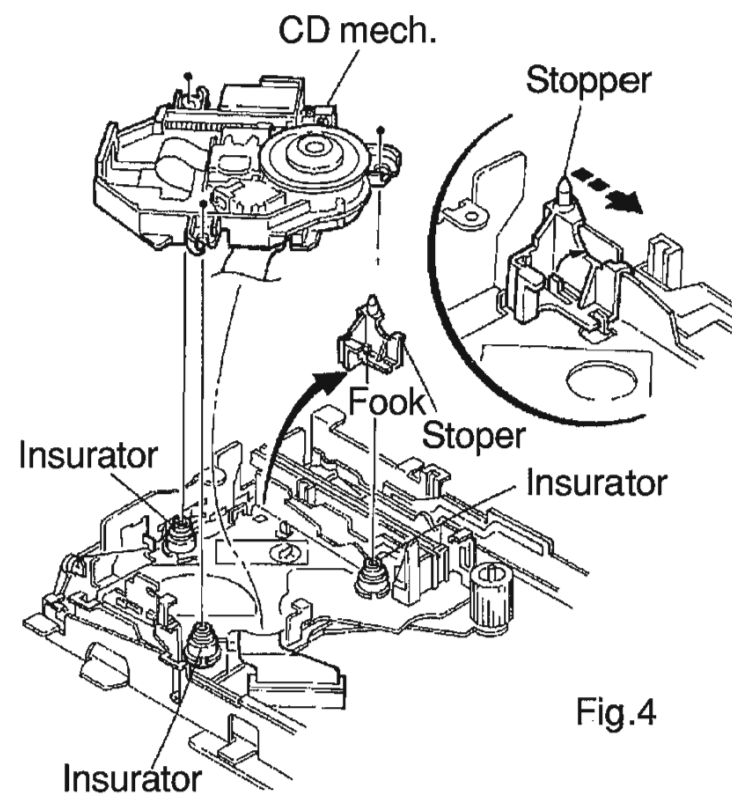

Fig.4

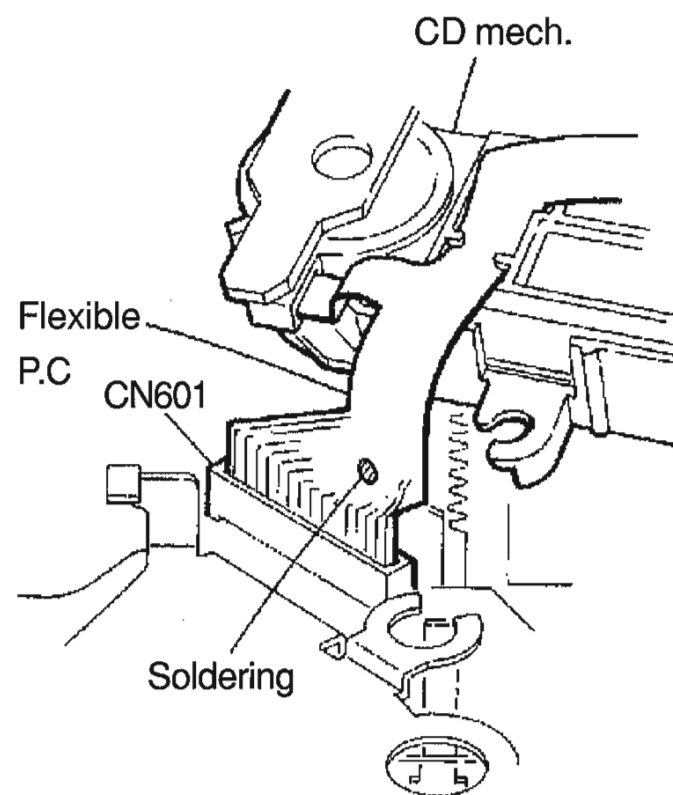

Fig.5

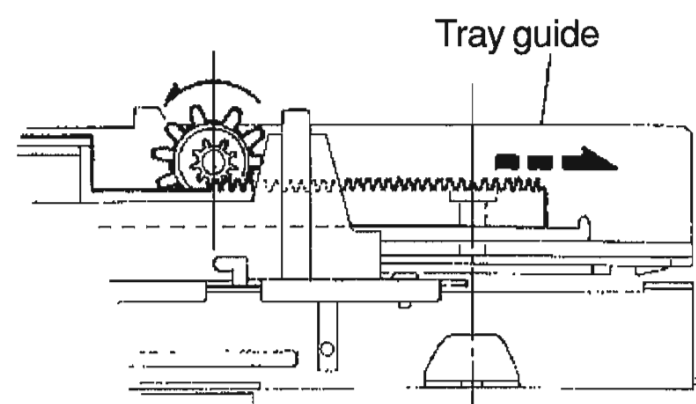
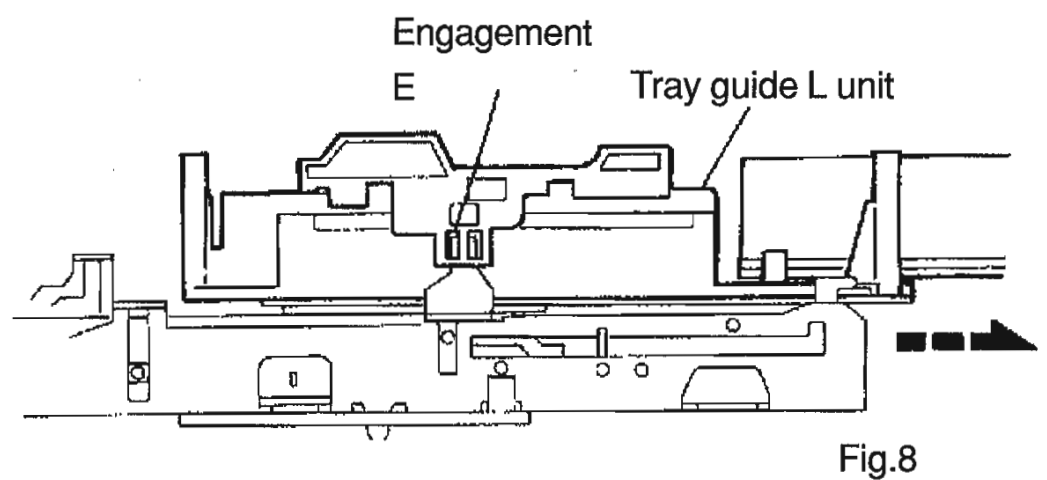
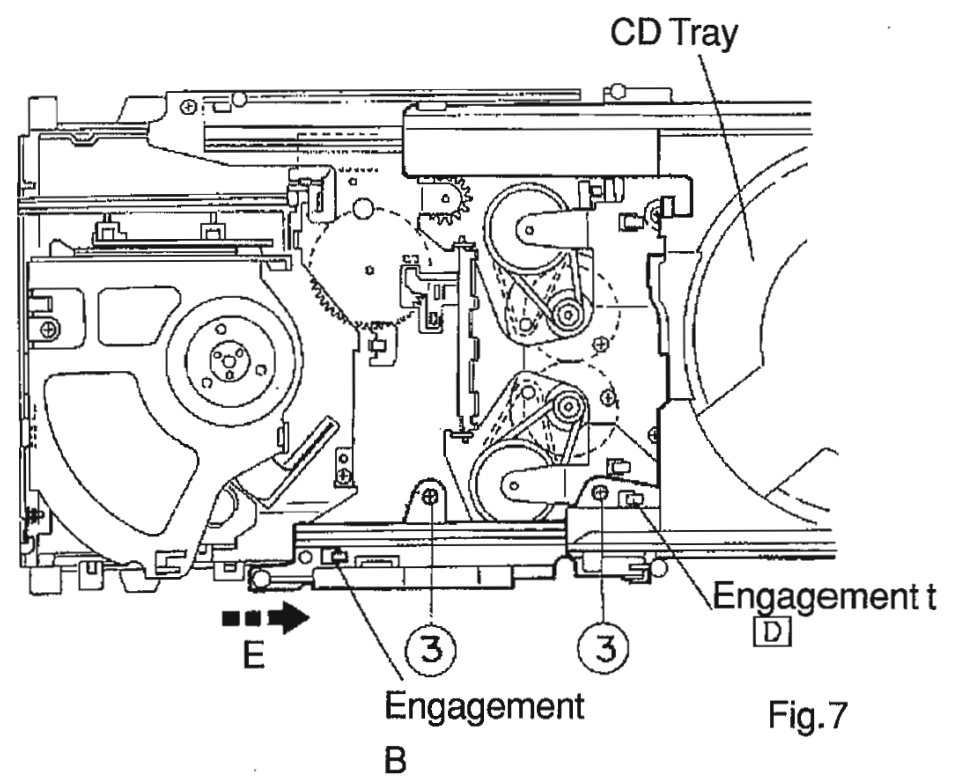

Fig.6

■ Removing the CD Tray

- 1.Remove the top cover.
- 2.Pull out the CD tray.
- 3.Remove the two screws ③ retaining the tray guide(L)unit(See Fig.7).
- 4.Disengage the two engagements D fixing the tray guide(L) unit while moving the engagements in the arrow D direction (See Fig. 8).
- 5.Pull out the engagement E from the mechanism chassis,and remove it together with the CD tray (See Fig.8).



■ Removing the CD traverse Mechanism
Control & P.C.Board

- 1.Remove the top cover.
- 2.Pull out the CD tray.
- 3.The two belts which have been dismantled from the tray & cam drive motor should be hanged again to the motor pulley as shown in Fig.9.
- 4.Remove the two screws ④ retaining the tray & cam drive motor (See Fig.9).

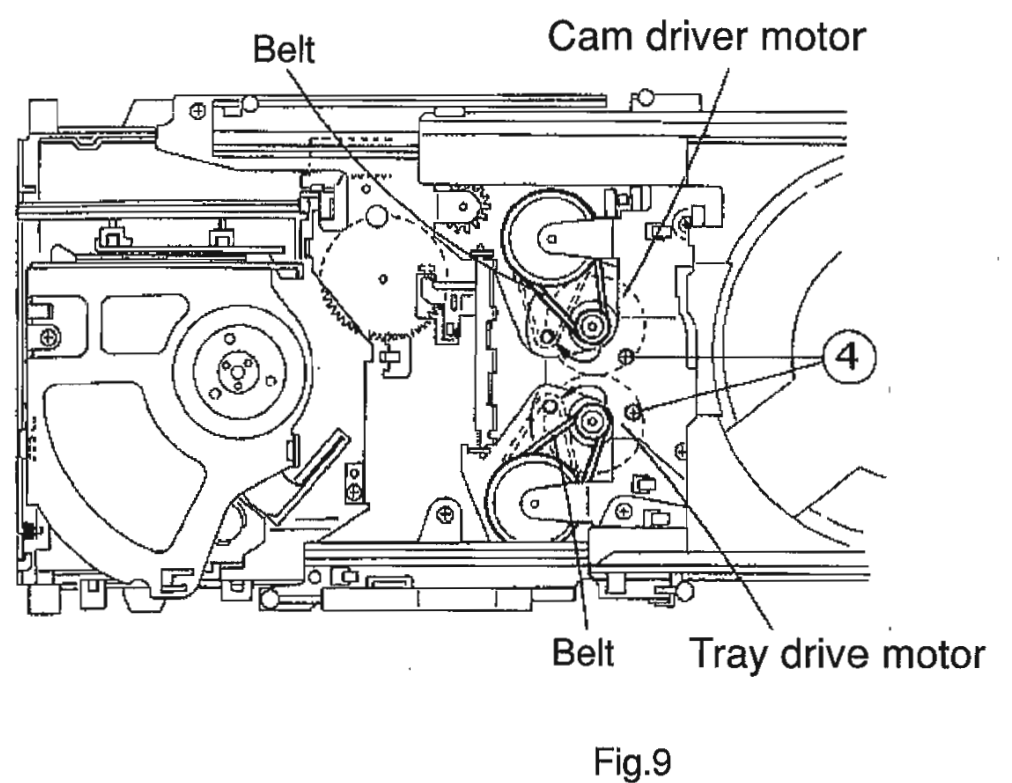

XT-TD5/XT-TD55R

5. After turning over the CD traverse mechanism, remove the four screws 5 retaining the CD traverse mechanism control & servo P.C. board (See Fig. 10).
6. While raising the P.C. board, perform soldering to fill the position on the flexible P.C. board outgoing from the CD pickup unit (See Fig. 11).
7. After turning over the CD traverse mechanism, remove the flexible P.C. board from the connector CN601 on the CD traverse mechanism control & servo P.C. board (See Fig. 11).
8. Remove the CD traverse mechanism control & servo P.C. board.

● Procedures for Reassembling the CD Traverse Mechanism Control & Servo P.C. Board

- In principle, this P.C. board should be reassembled according to the opposite removing steps. For mounting the CD traverse mechanism control & Servo P.C. board, insert the main switch (blue) on the P.C. board into the position in Fig. 12.
- Be sure to hang the two belts which have been dismantled from the tray & cam drive motor.

■ Removing the Cam and Tray Drive Motors

1. Remove the top cover.
2. Pull out the CD tray.
3. Remove the CD traverse mechanism control & servo P.C. board.
4. After removing the two soldered portions [a] on the surface of the CD traverse mechanism control & servo P.C. board, remove the tray drive motor (See Fig. 13).
5. After removing the two soldered portions [b] on the surface of the CD traverse mechanism control & servo P.C. board, remove the cam drive motor (See Fig. 13).

CD traverse Mech./Control & servo PCB

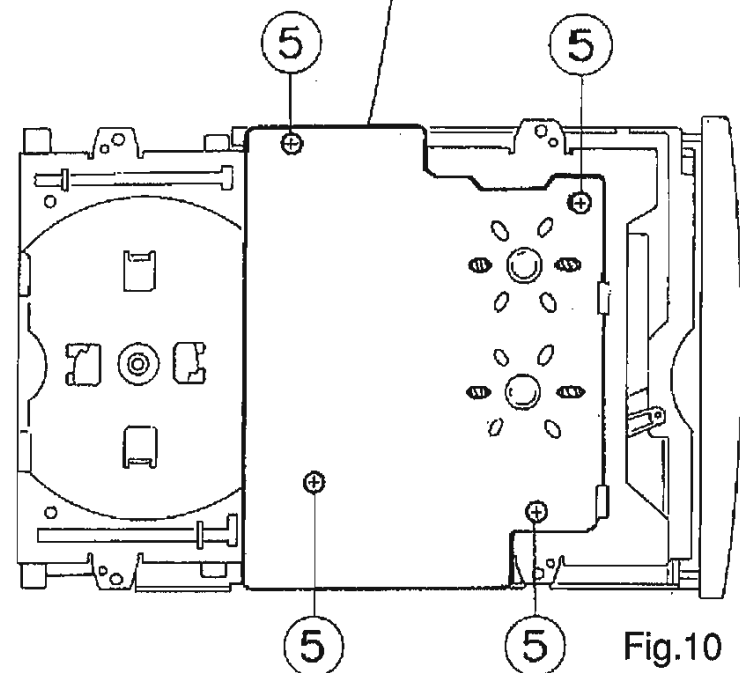

Fig.10

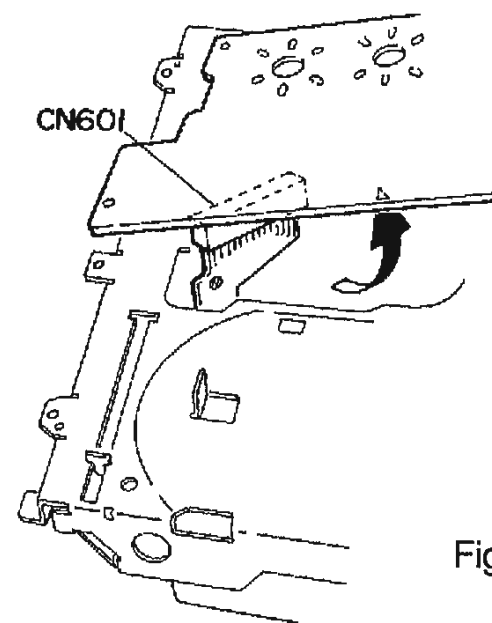

Fig.11

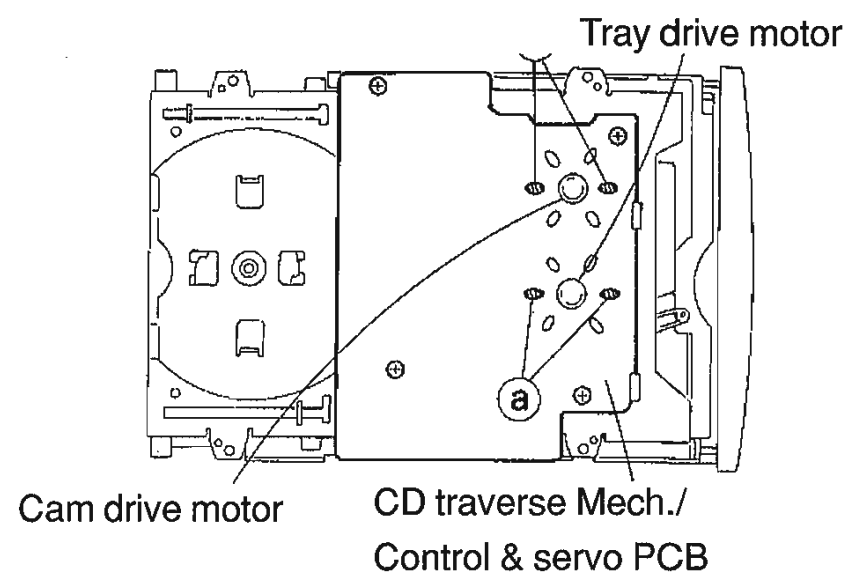
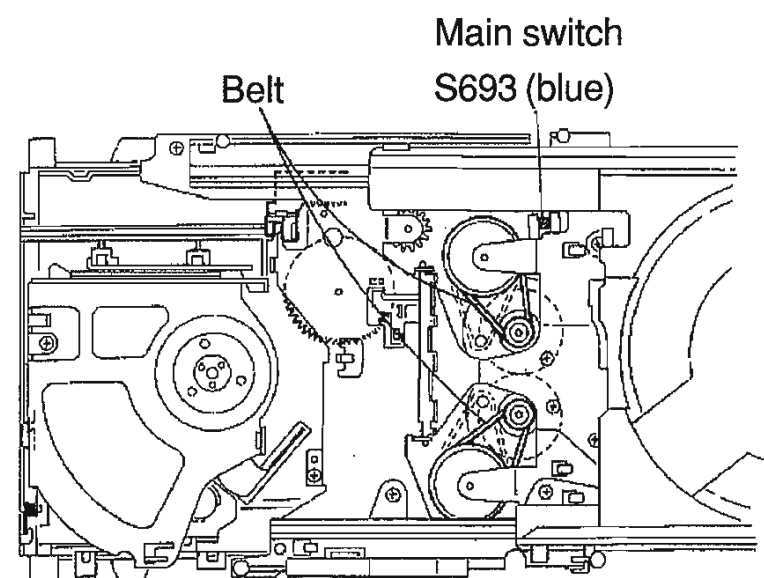

Fig.12

■ Removing the CD Pickup Unit

1. Remove the top cover.
2. Pull out the clamper.
3. Remove the CD mechanism.
4. Shift the CD pickup unit in the arrow F direction (See Fig.14).
5. Remove the one screw ⑥ retaining the shaft holder (See Fig.14).
6. After removing the two screws ⑦ retaining the rack arm, take out the S.S. gear assembly (See Fig.14).
7. By soldering, fill the position on the back surface of the CD pickup unit (See Fig.15).
8. Remove the flexible P.C.board from the connector on the back surface of the CD pickup unit.

● Procedures for Reassembling the CD pickup unit

- In principle, this unit should be reassembled according to the opposite order of the removing steps.

Caution

The rack arm should be screw-clamped first from the round hole.

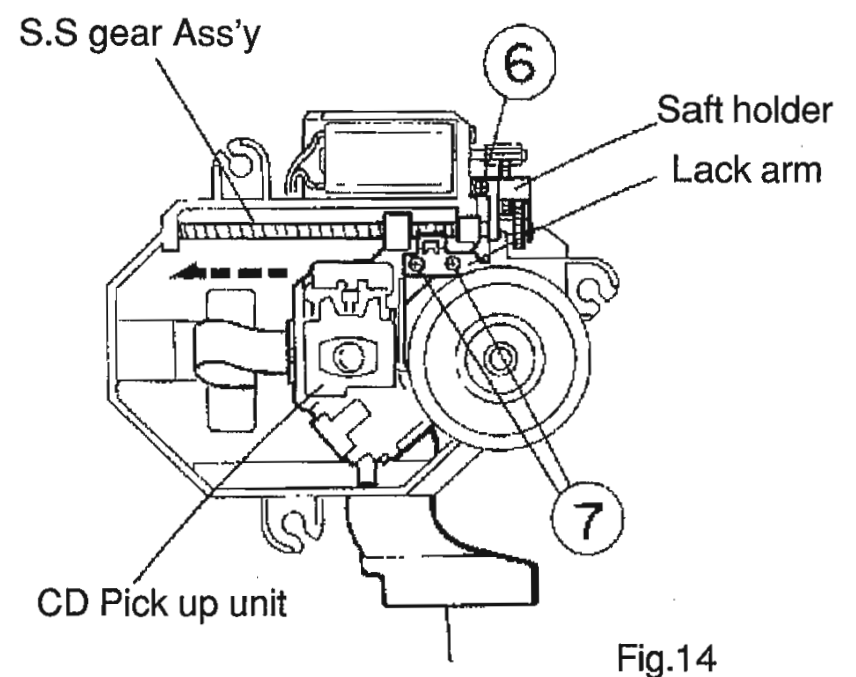

Fig.14

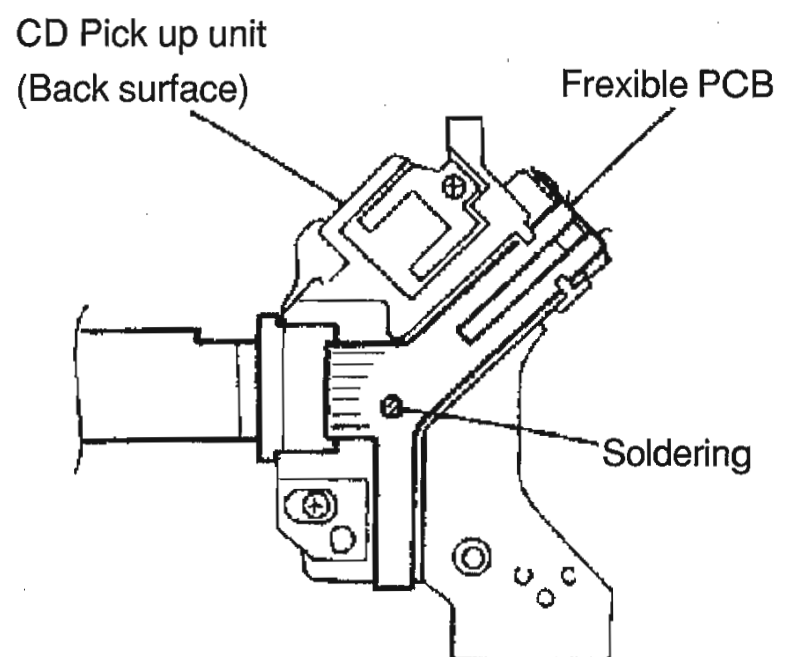

Fig.15

■ Removing the Feed Motor Assembly

1. Remove the top cover.
2. Pull out the clamper.
3. Remove the CD mechanism.
4. After removing the one screw ⑧ retaining the feed motor assembly, take out this assembly (See Fig.16).
5. After turning over the CD mechanism, remove it from the lead wire treating key way on the feed motor assembly (See Fig.16).
6. Remove the soldered portion of the lead wires (red and black) from the spindle motor P.C.board (See Fig.16).

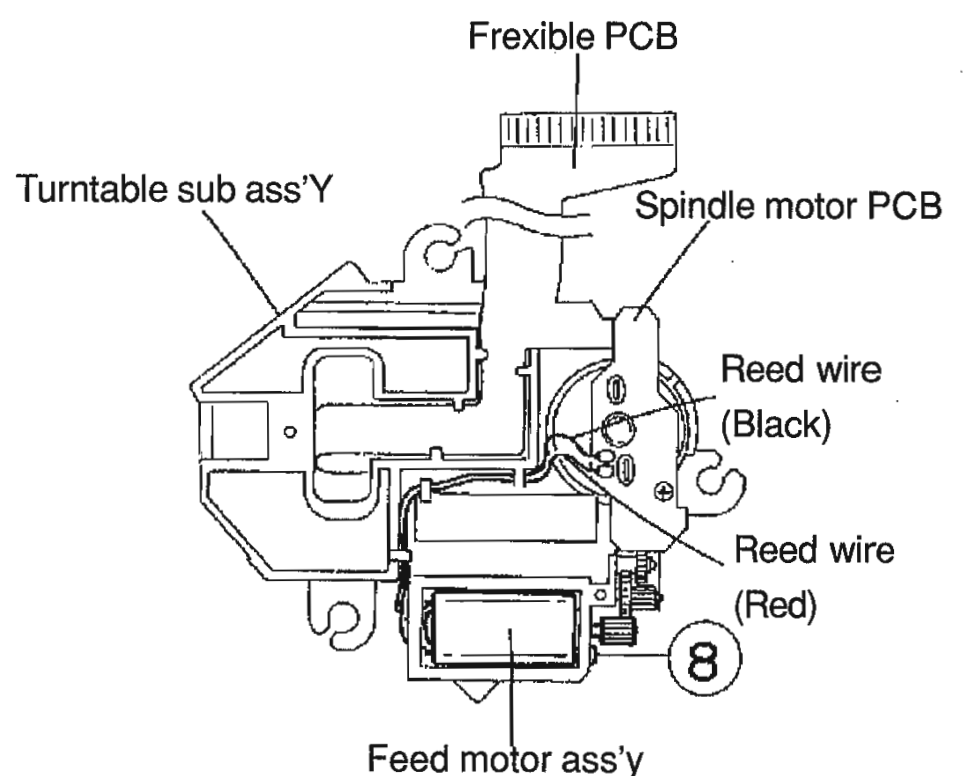

Fig.16

XT-TD5/XT-TD55R

■ Removing the Spindle Motor Assembly

1. Remove the top cover.
2. Pull out the clamper.
3. Remove the CD mechanism.
4. Remove the CD pickup unit.
5. Pull out the middle gear.
6. Remove the feed motor.
7. After turning over the CD mechanism, remove the two soldered portions (C) on the spindle motor P.C. board.
(See Fig. 17).
8. After removing the flexible P.C. board from the connector CN699 on the spindle motor P.C. board take out the flexible P.C. board from the turntable sub-assembly.
(See Fig. 17).
9. The spindle motor and turntable will not be supplied individually as single units but as a turntable sub-assembly (in combination with the spindle motor, turntable and mechanism chassis). Therefore, be sure to change the sub-assembly instead of changing the individual spindle motor or turntable alone.

Caution: Since LOCK-TIGHT 460 is applied for press-in sections of the turntable and spindle motor shaft, be sure to remove the shaft so carefully as not to cause any damage to the spindle motor.

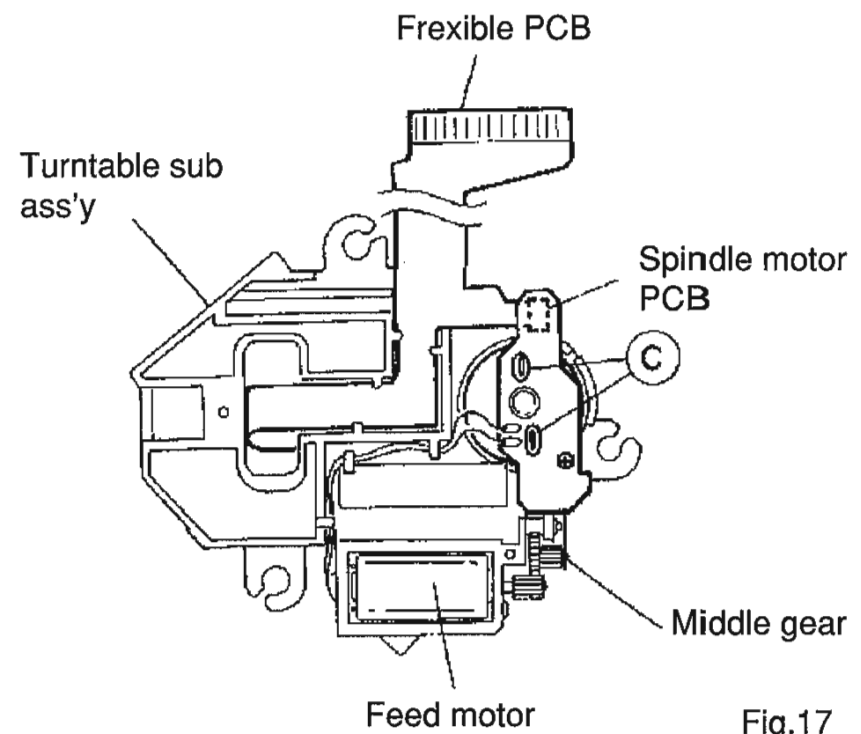

Fig.17

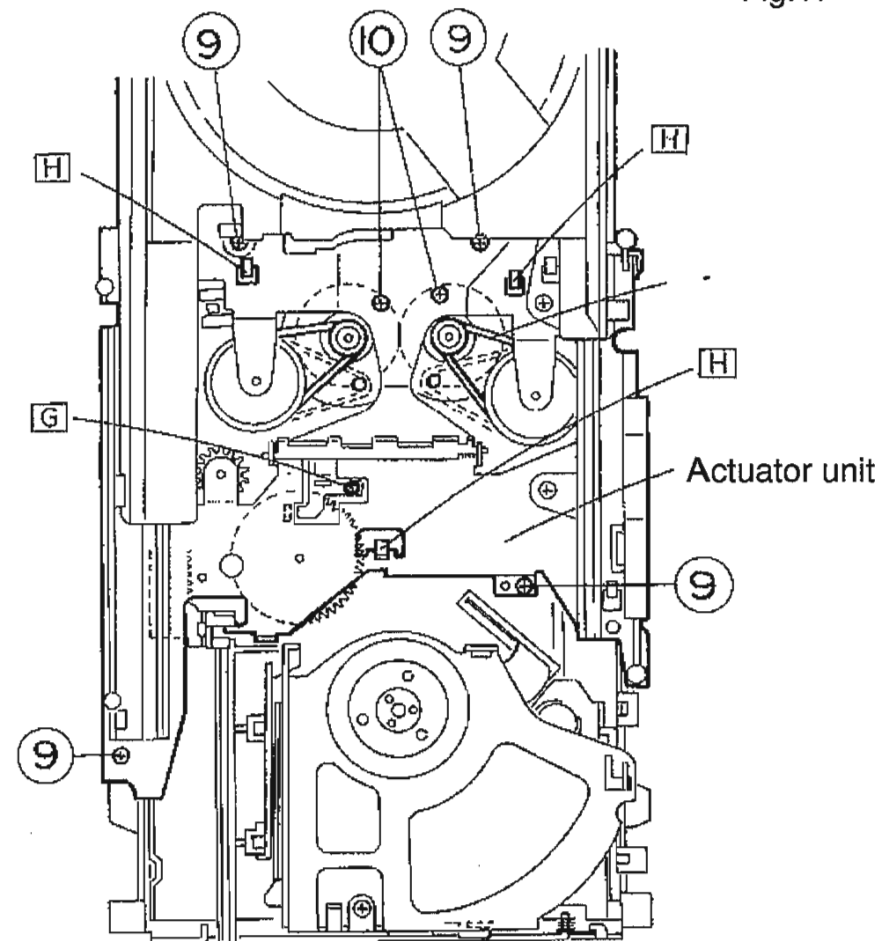

Fig.18

■ Removing the Actuator Unit

1. Remove the top cover.
2. Remove the CD tray together with the tray guide (R).
3. Remove the four screws $\neq H$ retaining the actuator unit.
(See Fig.18).
4. Remove the two screws $\neq I$ retaining the tray & cam drive motor.
(See Fig. 18).
5. Hang the two belts removed from the tray and cam drive motor again to motor as shown in Fig. 18.
6. While holding down the section (G) with a finger, remove the two pawls H retaining the actuator unit.

Method of pulling out the CD tray in case the CD driver mechanism has been dismantled under [PLAY] mode

1. Press forward the hock slider assembly until it stops as shown in Fig. 19.
2. Move the slide cam (L) on the left side of the CD driver mechanism assembly in the arrow A direction and position it to (A). Then, the CD driver mechanism will be kept at the lowered position (See Fig. 1).

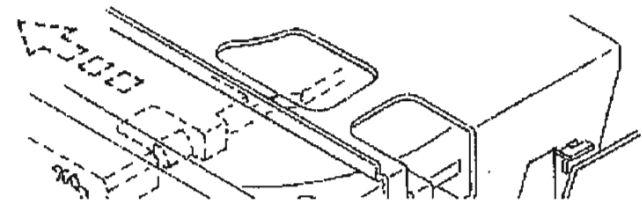

■ Deck Adjust point

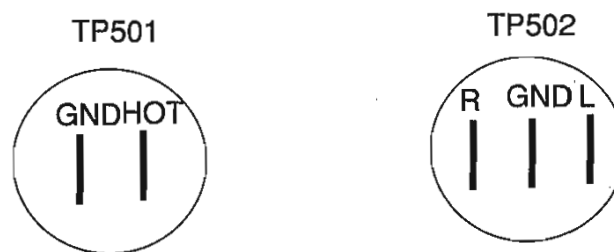
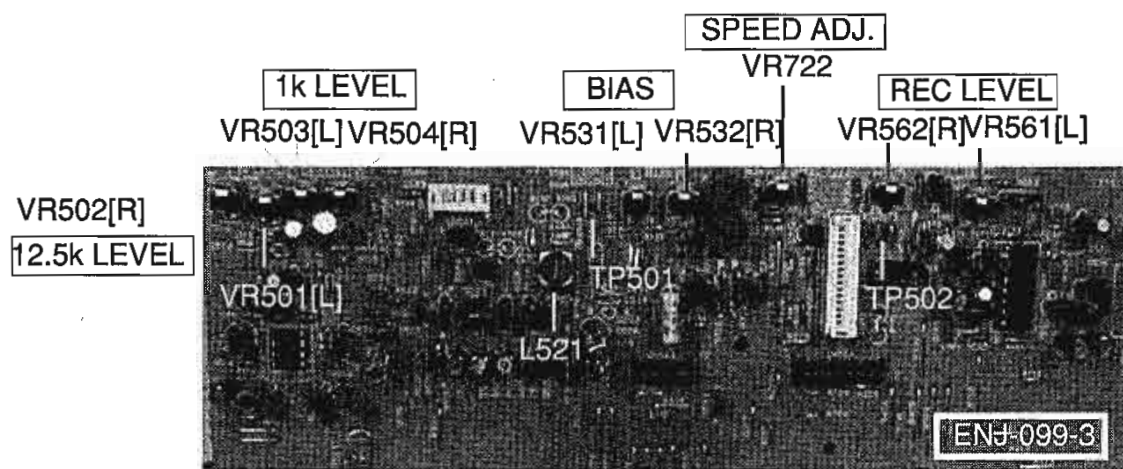

Deck section

1.Measuring instruments

- Audio frequency signal generator (0db output at 600ohm output terminal from 50Hz to 20kHz)
- Electronic voltmeter
- Frequency counter
- Wow & Flutter meter
- Distortion Meter with band filter
- Attenuator(600 ohm impedance)
- A resistor with 600Ω

Tape No.	Frequency	Level(Wow & Flutter)	Purpose
VTT-703L	10kHz	-10dBs	Head azimuth, Frequency Response
VTT-712	3000Hz	0dBs 0.025%WRMS	Tape Speed, Wow & Flutter
VTT-724	1kHz	-4dBs	Standard Level
TMT-6447	-	-	Blank Skip
TMT-6247, TMT-6237	-	-	Music Scan
TMT-7088S	-	-	Recording standard Normal:UR
AC-712	-	-	Recording standard METAL :MA
AC-513	-	-	Recording standard CrO2:UR
TW-2111, TW2121	-	-	Forward/reverse play torque measuring
TW-2231	-	-	Feed forward/rewind torque measuring
C-120 Tape	-	-	Confirming the tape running

2.Adjustment and repairing the mechanism

Item	Adjustment method	Standard value	Remarks
Head azimuth	1.Connect an electronic viltmeter to the NR TP502 (figure2) to playback VTT-703L 2.Adjust screw [A] so that the indication of the viltmeter becomes maximum when play(▶) is pressed. 3.Adjust screw [B] so that the indication of the viltmeter becomes maximum when play(◀)	Maximum	1.Refer to figure 3. 2.When the specified characteristic cannot be obtained because of head wear,excessive magnetization,etc, replace the head assembly and adjust the head azimuth.Also,perform the electric adjustment. 3.When there is the difference of more than 3~4 dB between left and right output levels,replace the head assembly to avoid complaints.
Playback torque	1.Measure the torque in the playback mode by the torque meter.	26~72 g-cm	When the standerd torque cannot be obtained,replace the FR arm assembly or motor
Fast forward torque	1.Measure the torque in the fast forward mode by the torque meter.	75~175 g-cm	When the standerd torque cannot be obtained,replace the FR arm assembly or motor
Rewind torque	1.Measure the torque in the rewind mode by the torque meter.	75~175 g-cm	When the standerd torque cannot be obtained,replace the FR arm assembly or motor
Wow & Flutter	1.Connect the wow & flutter meter to the DOLBY TP (figure2)and play back VTT-712. 2.Its reading should be within 0.25%(WTD)	Less than 0.25%	As a comllaint may occur if the wow & flutter fluuctuates by 0.1% even though it is allowed in the standard,repairing is required.

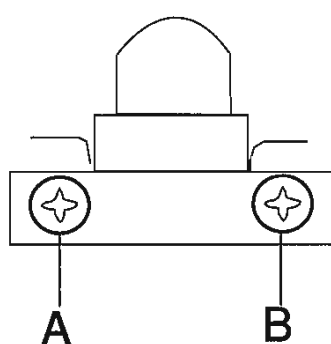

Fig.3

3. Electrical Adjustments (Make the following adjustments after adjustment the head azimuth.)

In principle, the adjustments should be made in the following sequence.
 Set the NR switch to OFF and the BEAT CUT switch to " 1 " .
 Adjustments marked with an asterisk (*) should always be made after the head is replaced

0dBs=0.775V

Item	Adjustment method	Adjustment Location	Standard value	Remarks
Tape speed	1. Connect a frequency counter to the NR TP502 (figure 2) and play back VTT-712 . 2. Adjust the semi-fixed resistor VR722 on ENJ-099 - 3 (figure 2).	VR722	3,000Hz ±10Hz	Connect a wow & flutter meter with a builtin frequency counter to the speaker terminals.
Standard level (Playback Level)	1. Connect an electronic voltmeter to the NR TP501 (figure 2) . Play back VTT-724 (1 kHz : -4dBs) to adjust the semifixed resistors.	L-VR503 R-VR504	488mV (-4dBs)	1) The playback level varies when the head is replaced so should be adjusted. Use an electronic voltmeter with an impedance of 100kΩ or more.
Playback Frequency Response	1. Connect an electronic voltmeter to the NR TP501 (figure 2) . 2. Play VTT-703L (10kHz : -10dBs) and adjust semifixed resistors to obtain the standard values.	L-VR501 R-VR502	245mV (-10dBs)	
Record/play Frequency Response (Bias current)	1. Supply 1kHz and 12.5kHz with 30mV signals to VCR terminals respectively to record them. 2. Connect an electronic voltmeter to the NR TP501 (figure 2) to confirm the recorded values. 3. If the values are not satisfied, adjust the semifixed resistors and record the signal again to confirm the recorded values.	L-VR531 R-VR532	0±2dB with 1kHz as the standerd	Refer to figure 4 below. 1) The recording and playback frequency response of a cassette deck are adjusted by adjusting the bias. 2) Perform the adjustment with normal tape and confirm that the values are within the range for metal tape.

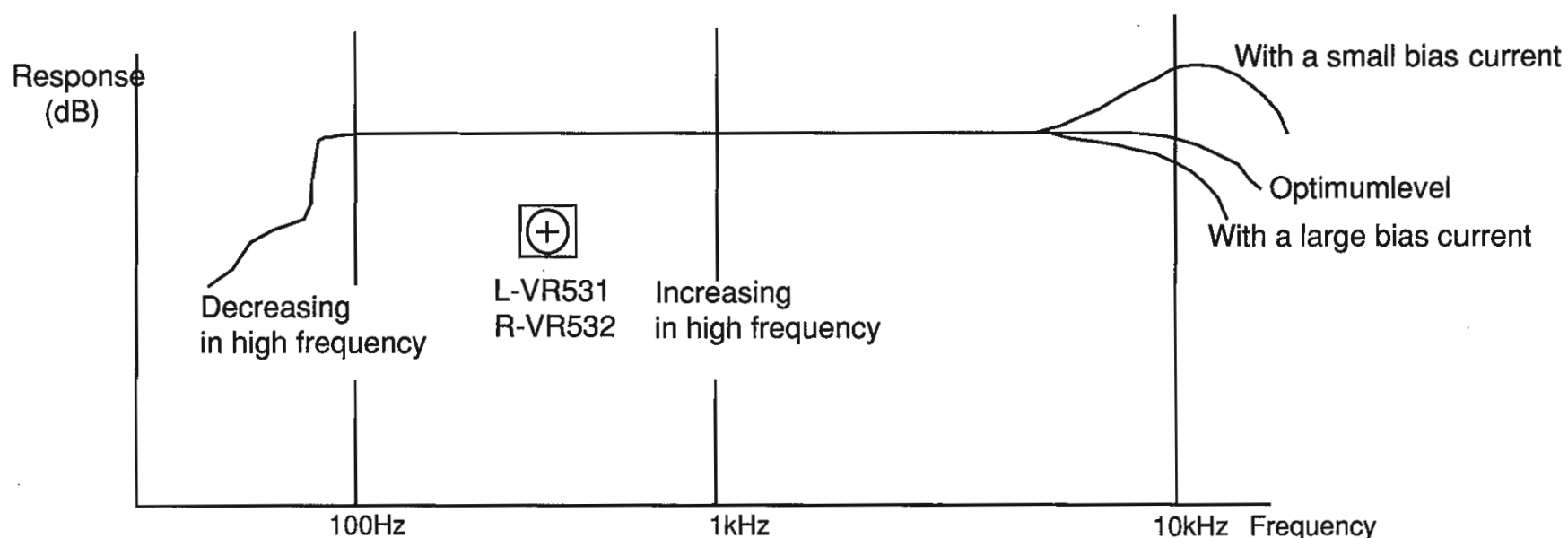
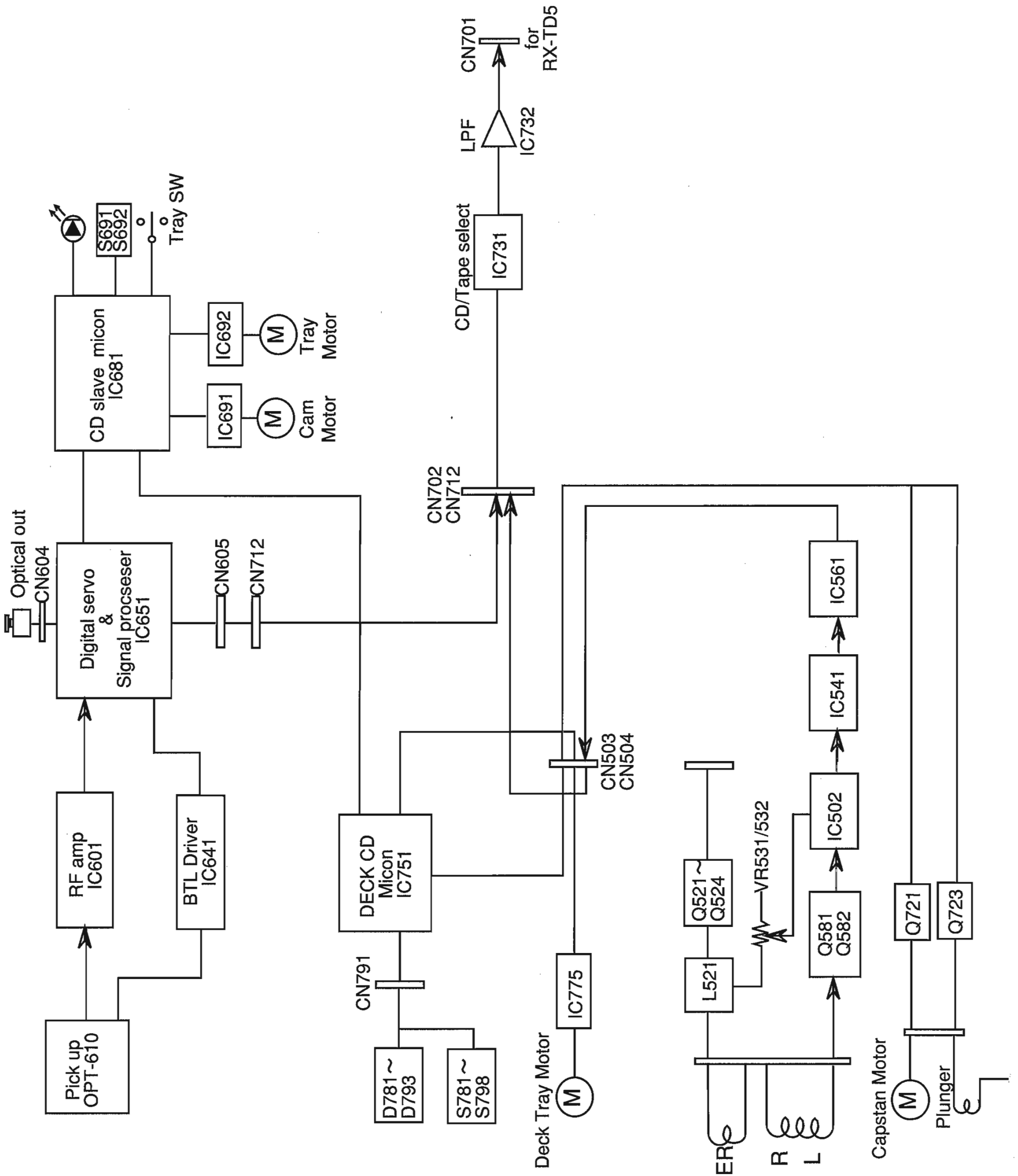

Fig.4

Block Diagram



P3-27-a

P3-27-b

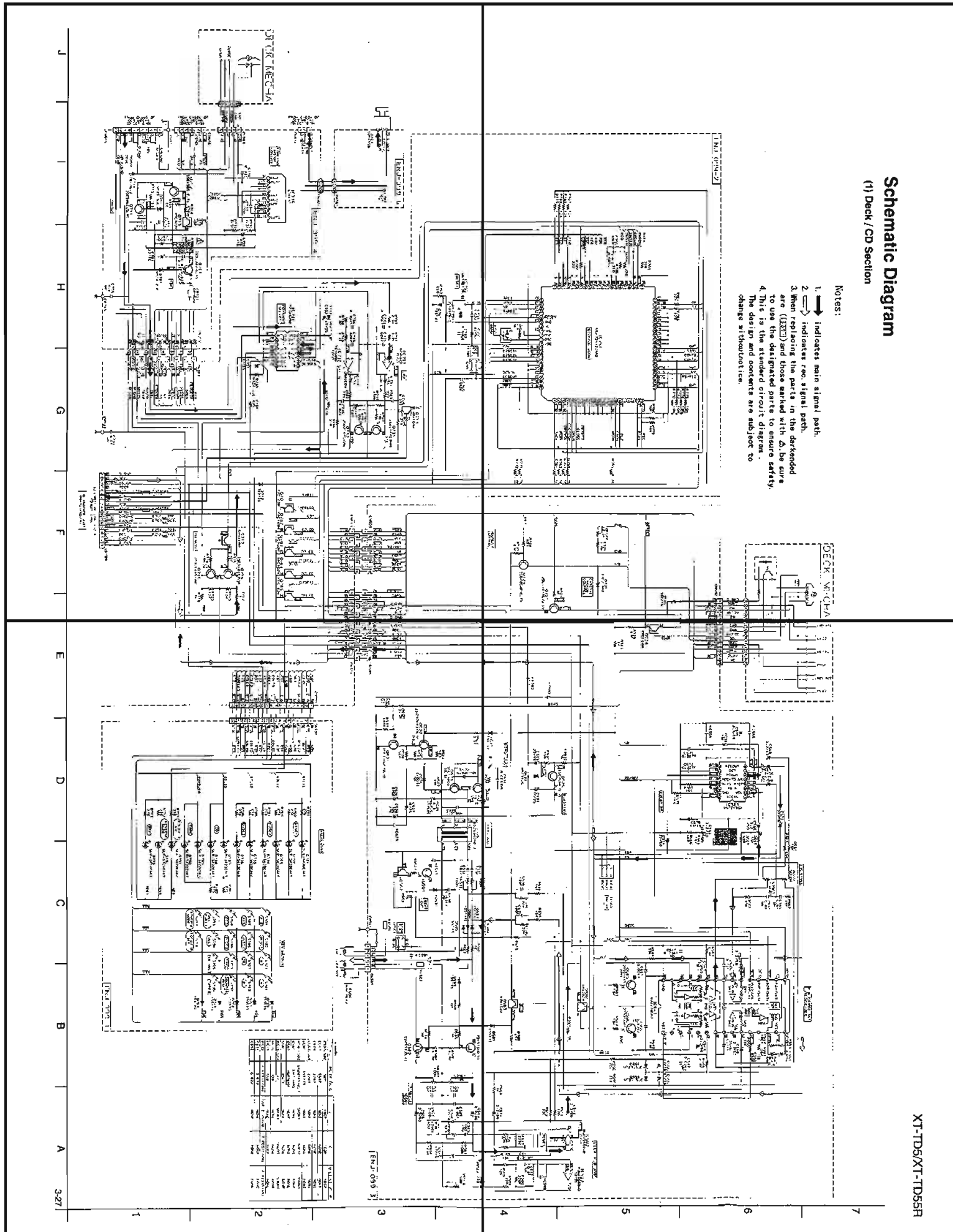

P3-27-c

P3-27-d

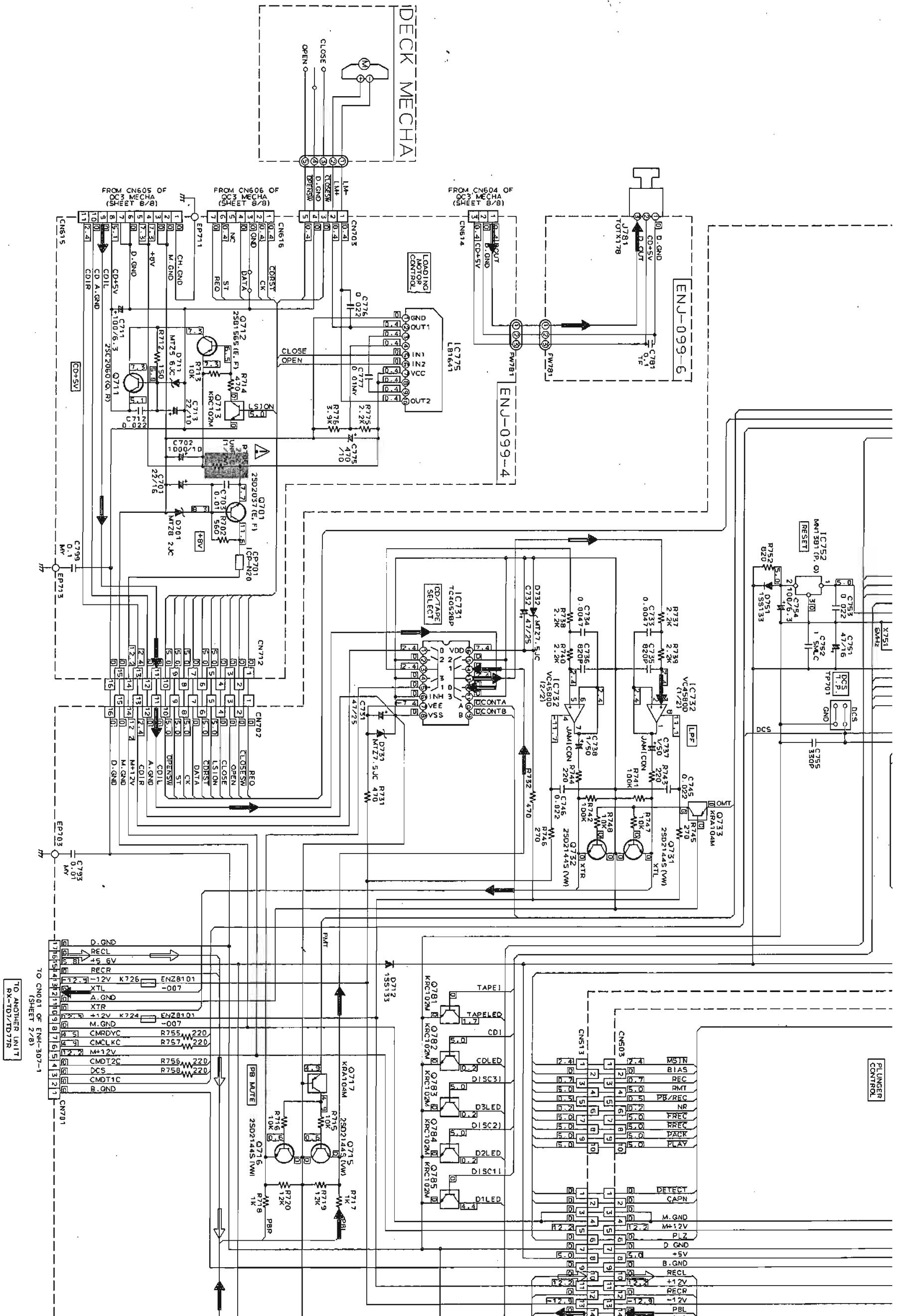

J

I

H



G

F

Schematic Diagram

(1) Deck / CD Section

Notes:

1.  indicates main signal path.
2.  indicates rec. signal path.
3. When replacing the parts in the darkened are () and those marked with Δ , be sure to use the designated parts to ensure safety.
4. This is the stander circuit diagram .
The design and contents are subject to change withoutnotice.

ENU-099-2

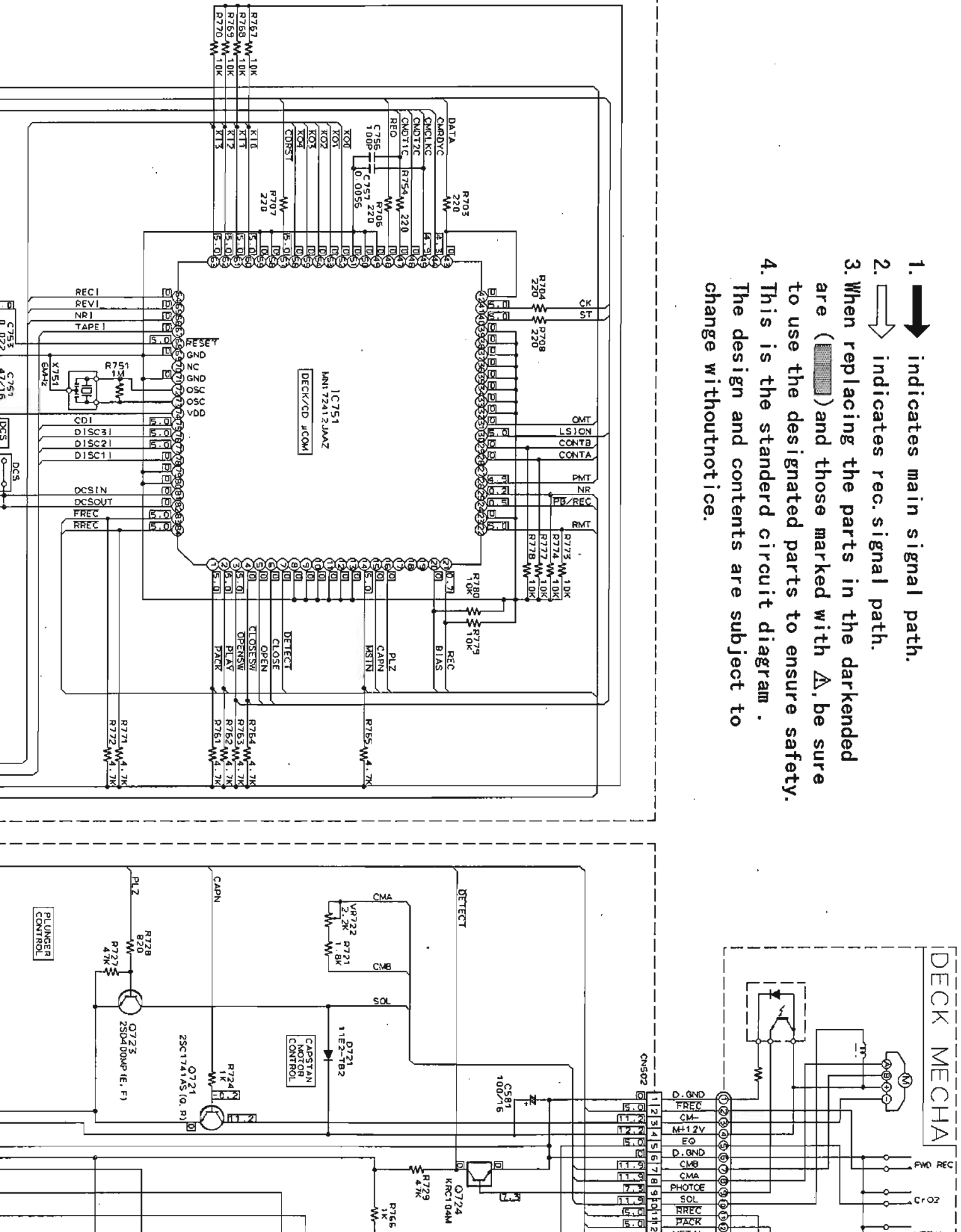

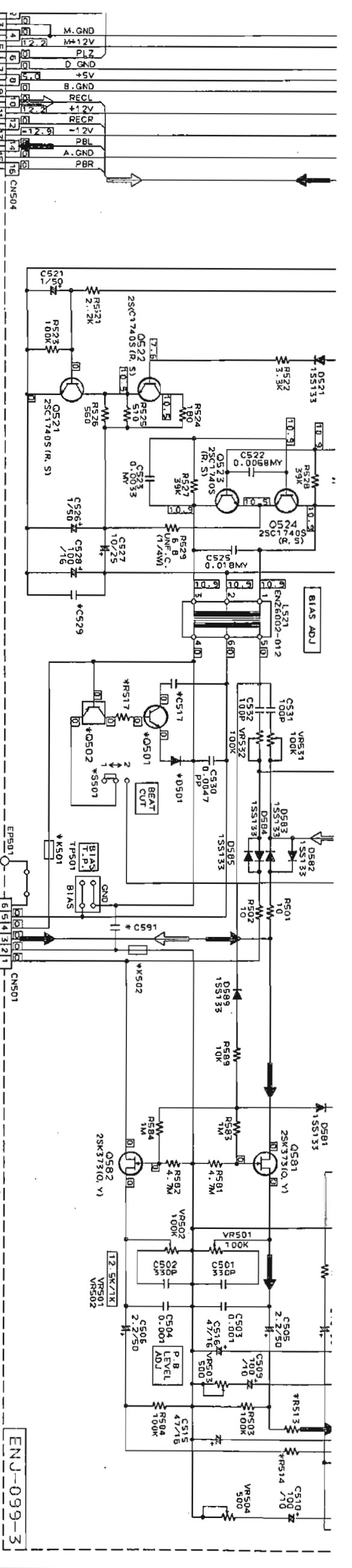

3

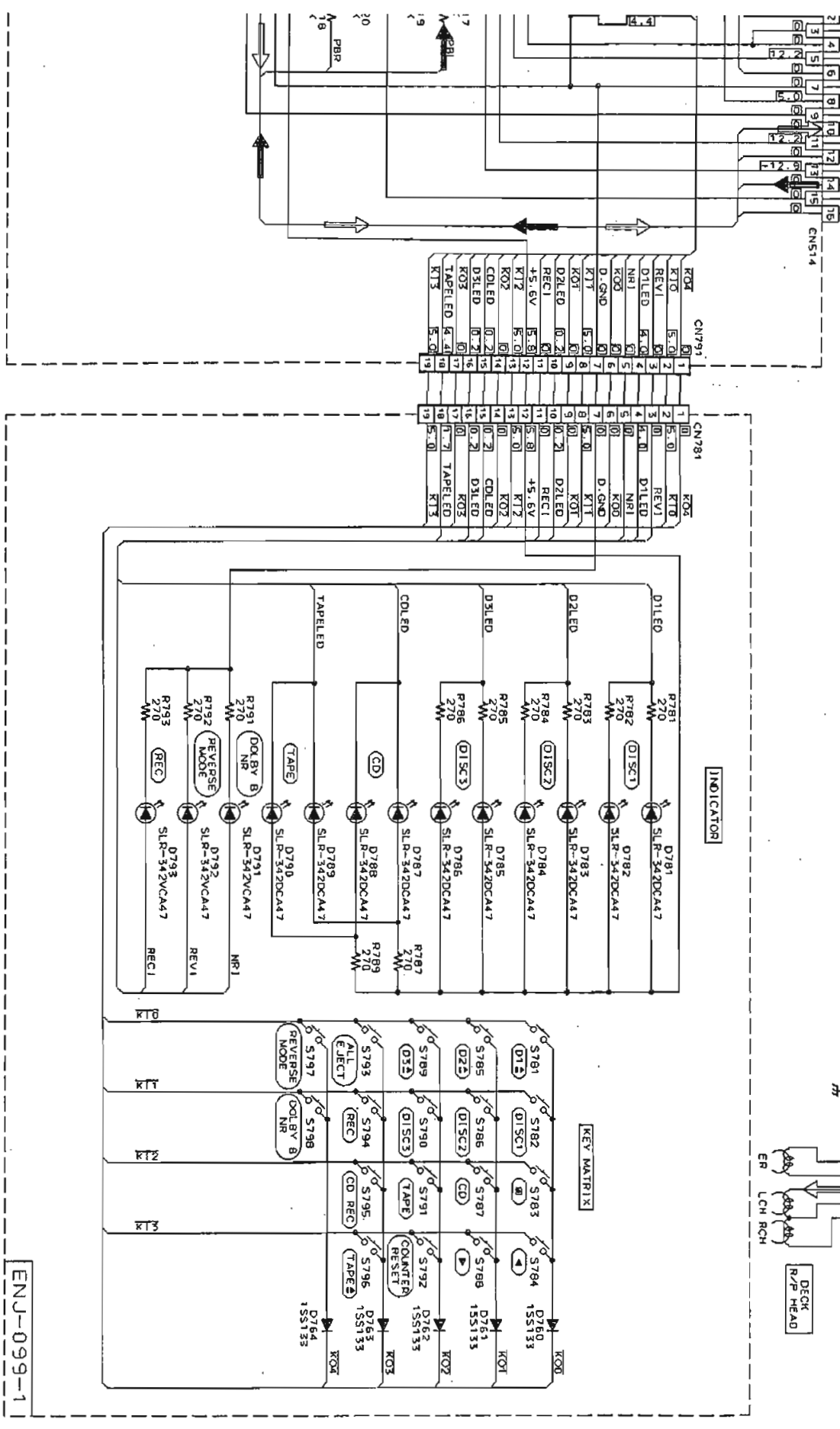

* MARK	BS. EF. EN. G.	J	C	V. UB. VS. UT. UP
C507, 508	56P	100P	100P	100P
C517	560P	NONE	NONE	NONE
C529	220P	NONE	NONE	NONE
C563, 564	220P	NONE	NONE	NONE
D501	1SS133	NONE	NONE	NONE
K501-503	EN28T01-007	SHORT	SHORT	SHORT
Q501	2SC1740S	NONE	NONE	NONE
Q502	KRA104M	NONE	NONE	NONE
S501	USED	NONE	NONE	NONE
R513, 514	47	SHORT	SHORT	SHORT
R515	220	SHORT	SHORT	SHORT
C517	560	NONE	NONE	NONE
R532	F. RES (1/4W)	NONE	NONE	NONE
C531	D. 0.22	NONE	NONE	NONE
C532	F. RES (1/4W)	NONE	NONE	NONE
C531	D. 0.22	NONE	NONE	NONE
C532	D. 0.22	NONE	NONE	NONE

2

E D C B A 3-27

XT-TD5/XT-TD55R

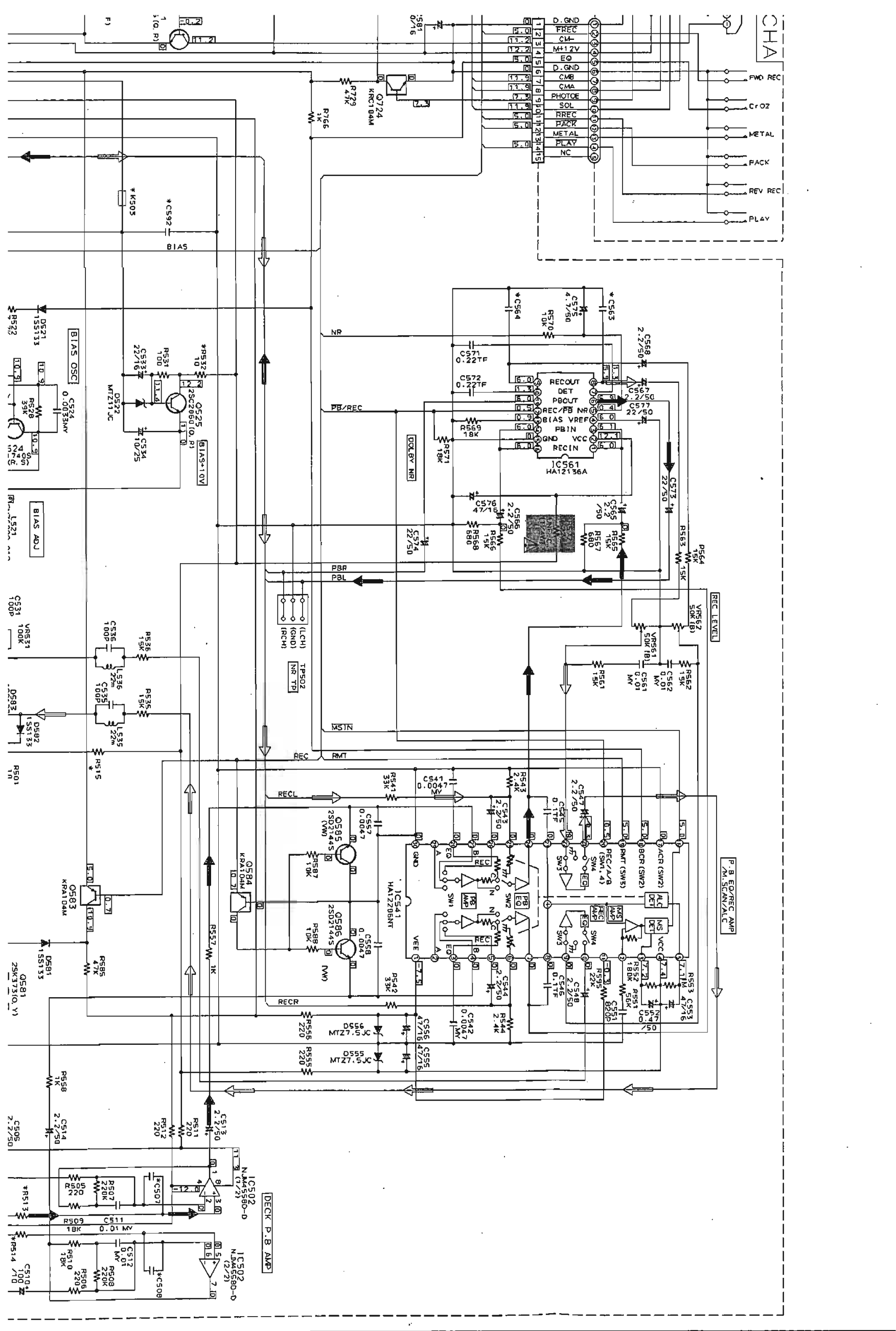

4 5 6 7

P3-28-a

P3-28-b

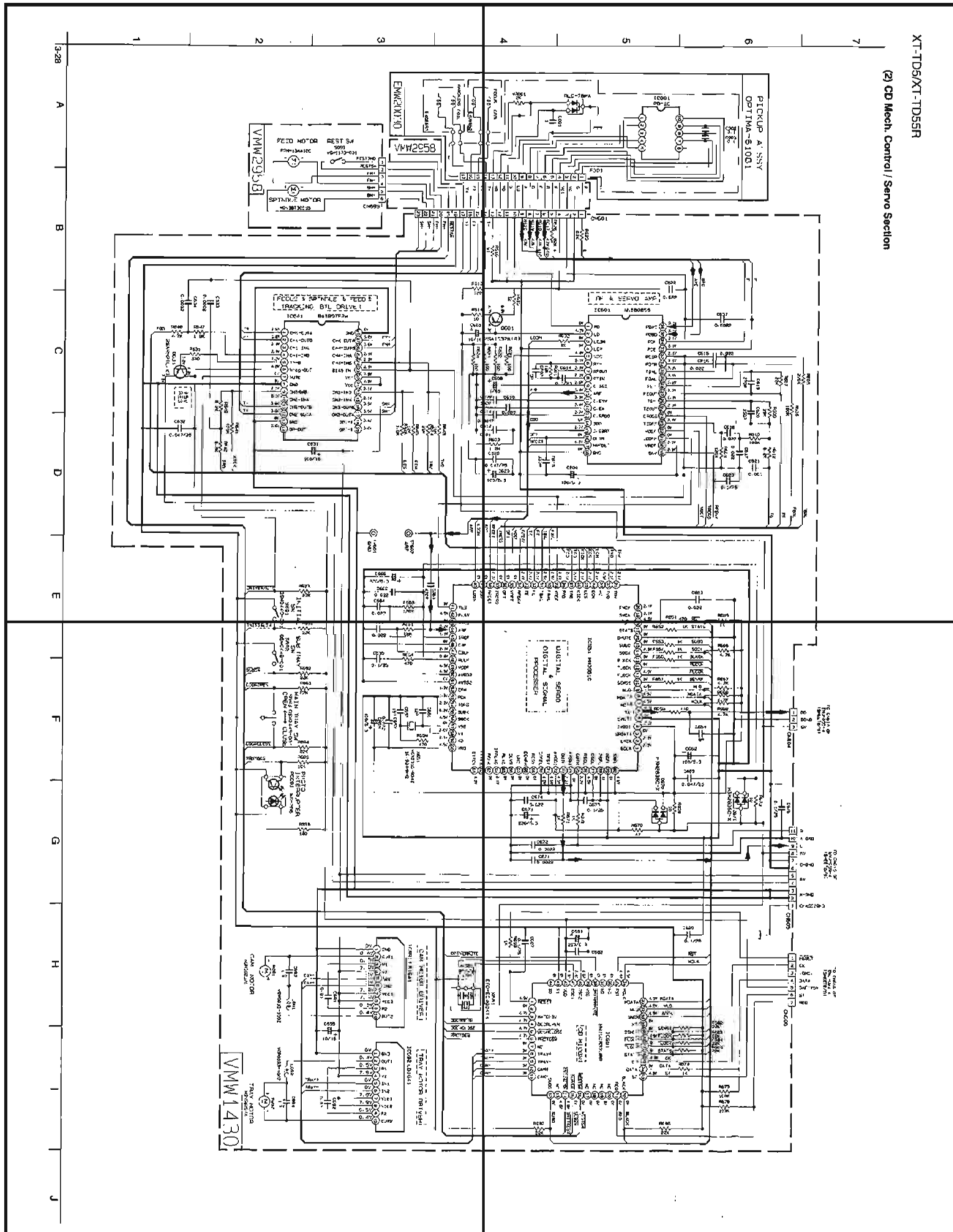

P3-28-c

P3-28-d

3-28

A

B

C

D

E

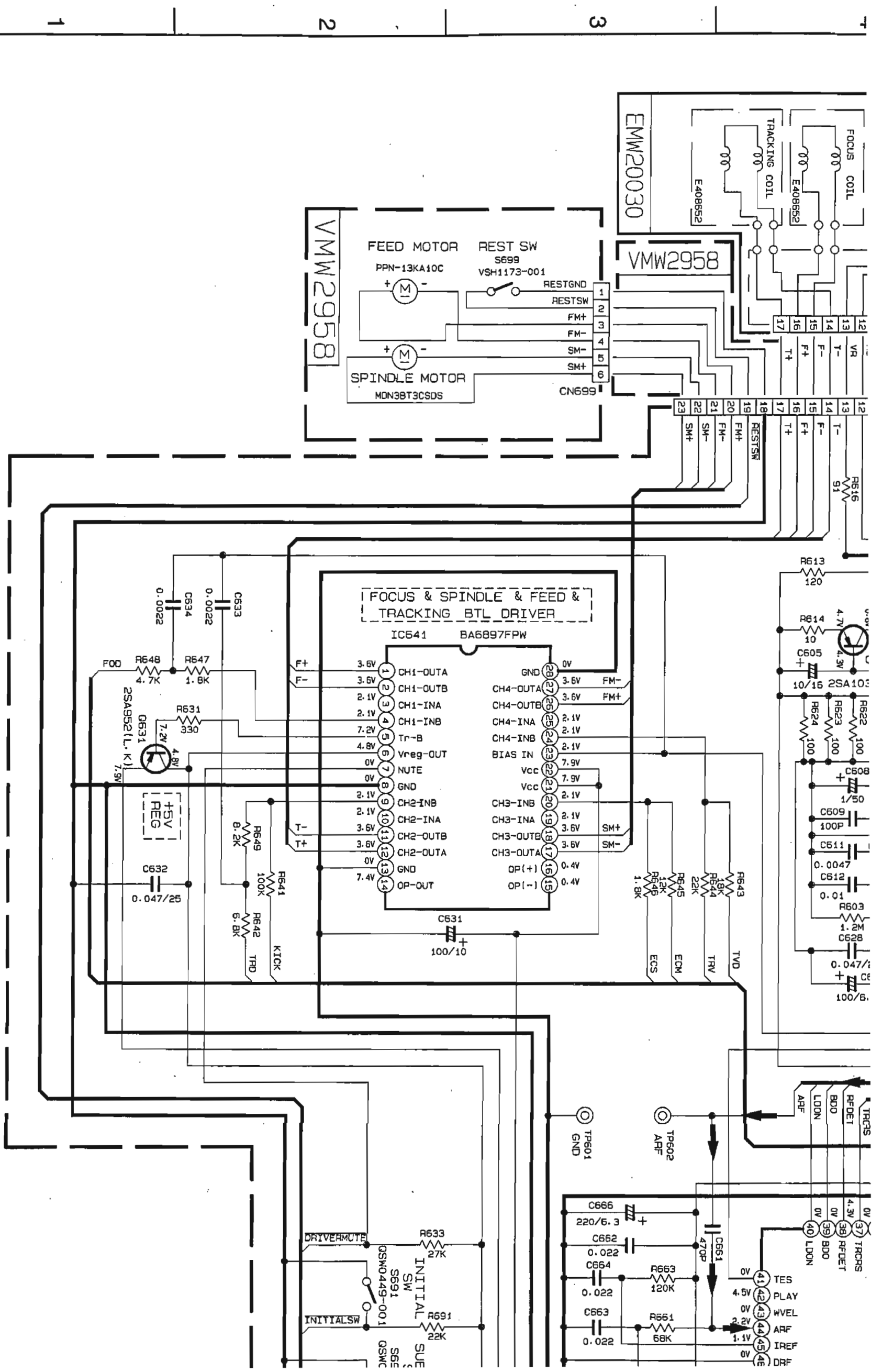

(2) CD Mech. Control / Servo Section

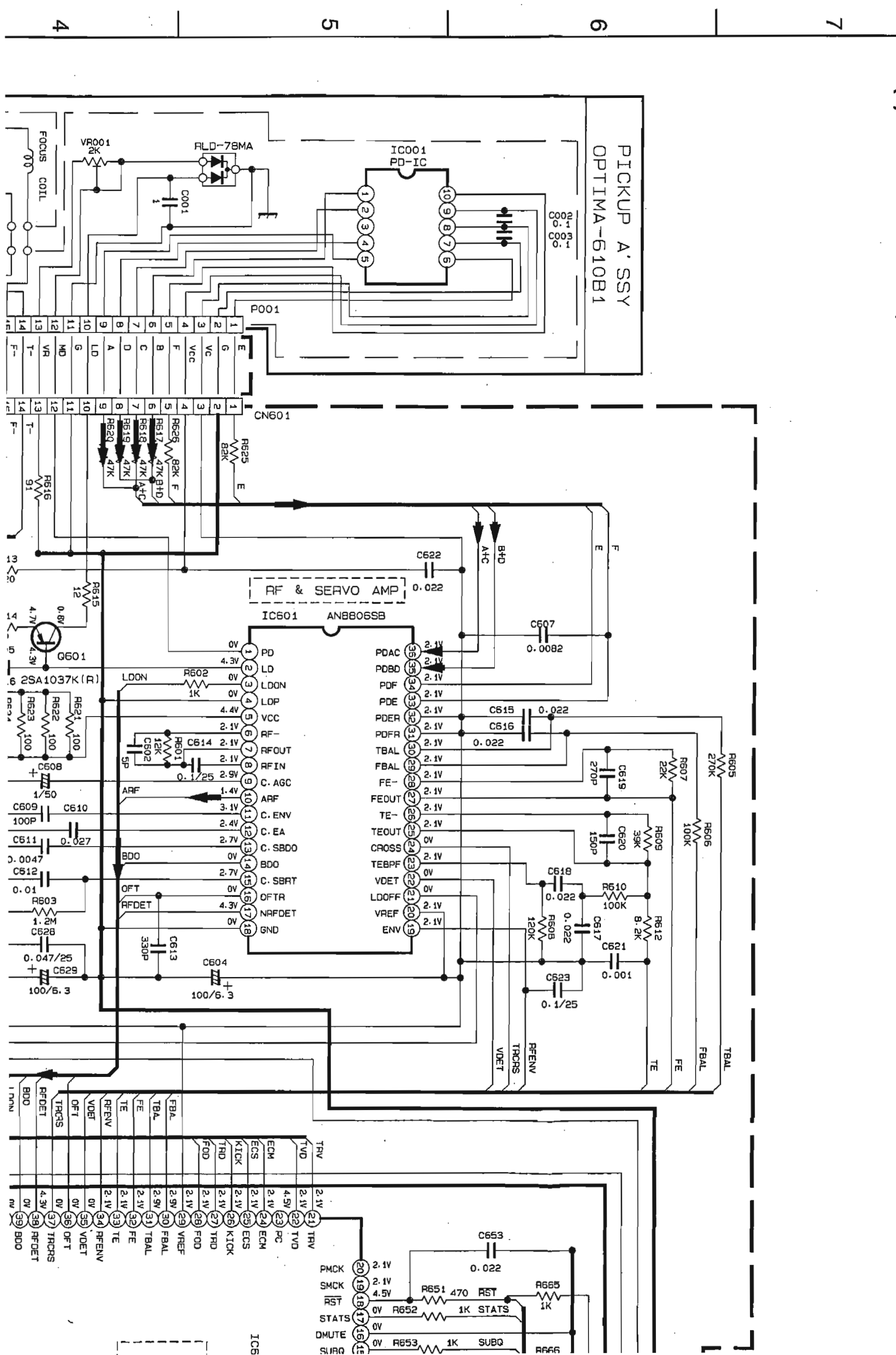

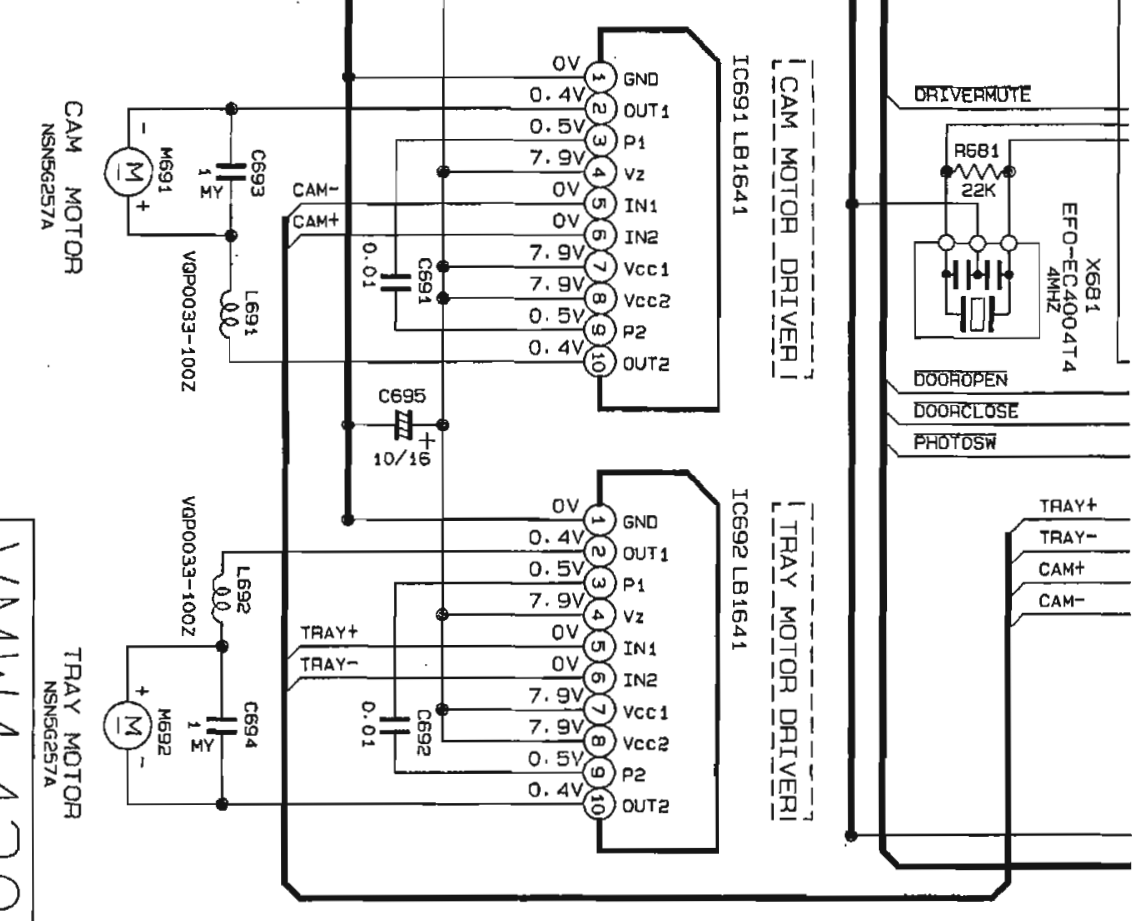
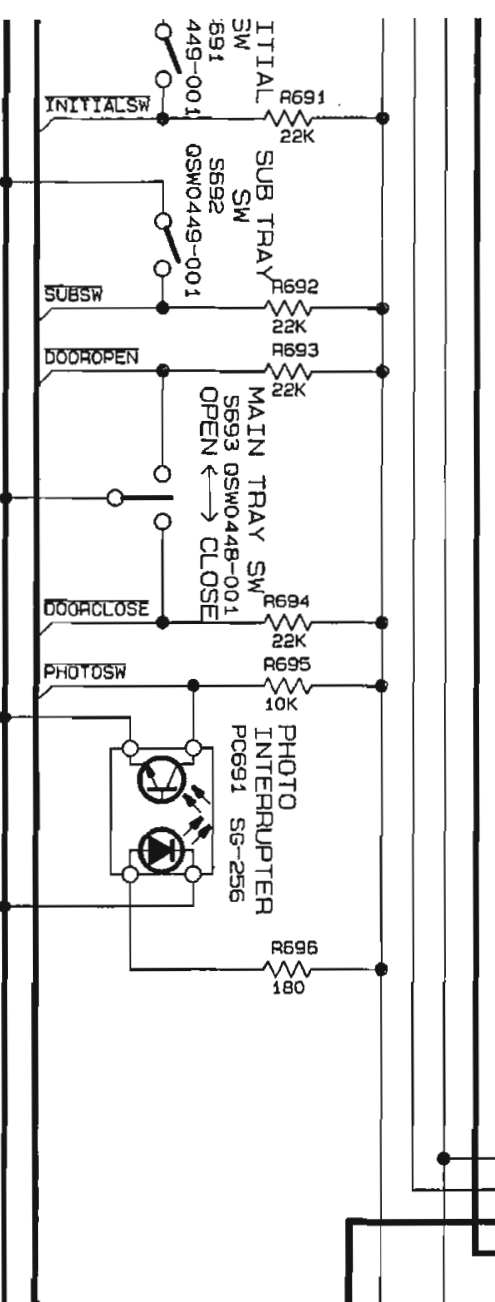
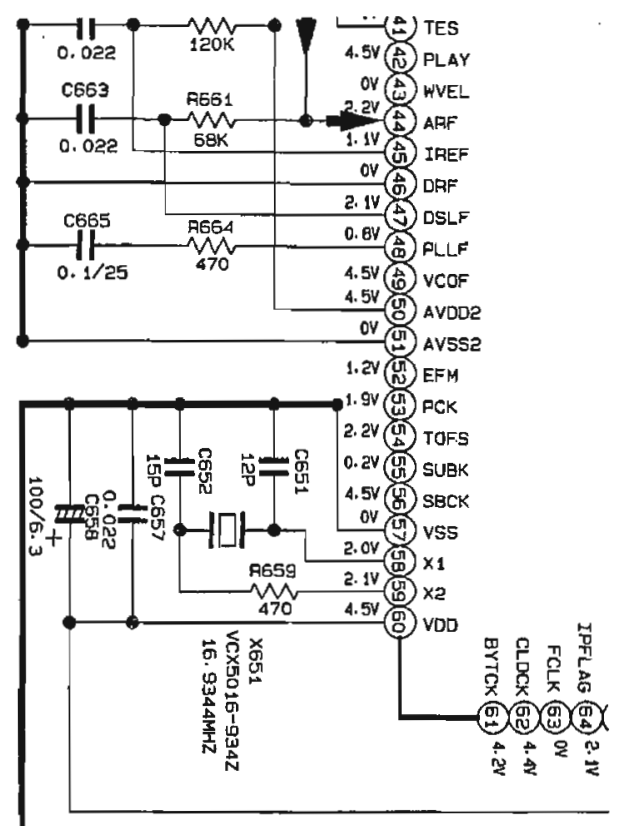

VMW1430

F G H I J

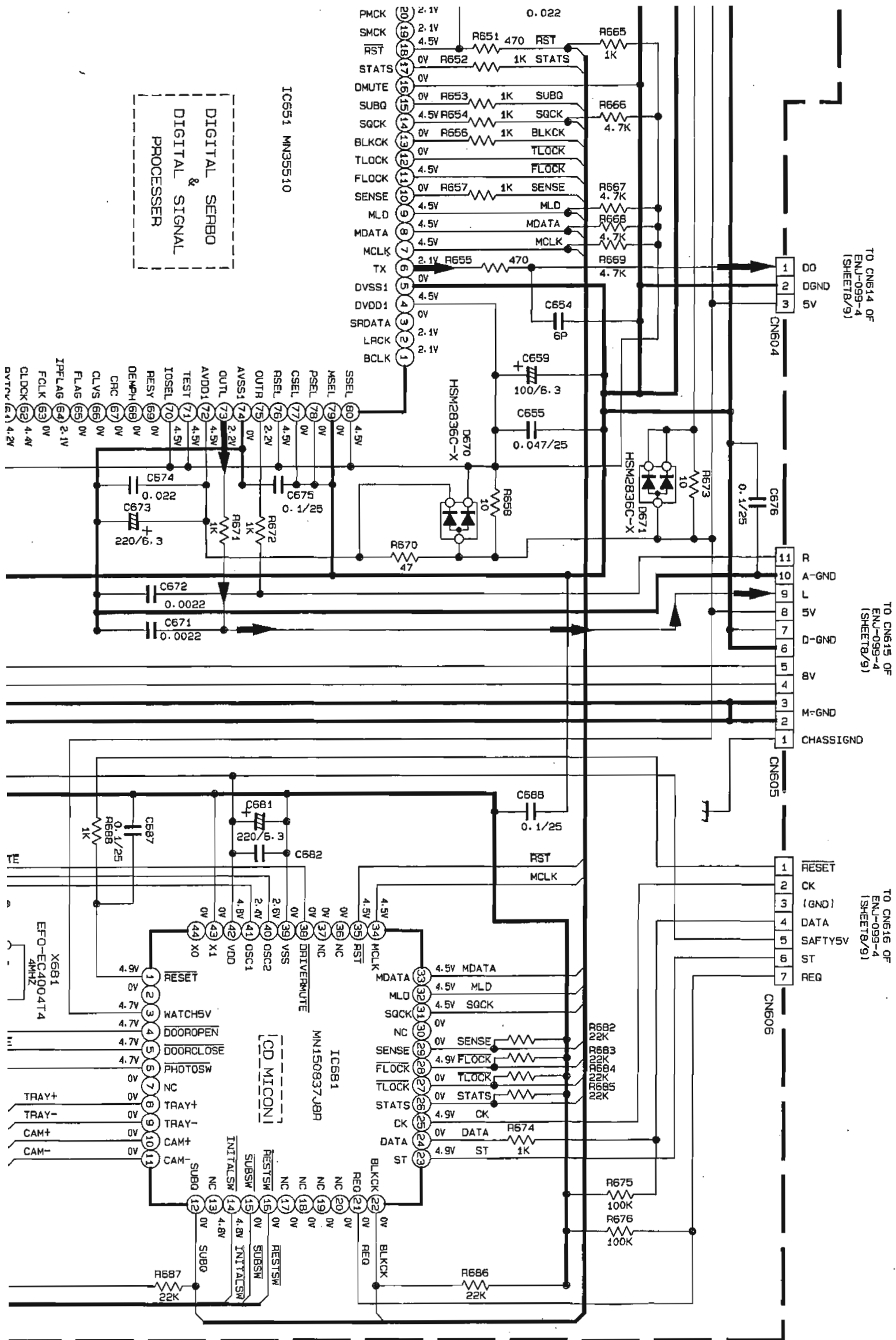

Printed Circuit Board

Deck / CD Control P.C.Board (ENJ-099)

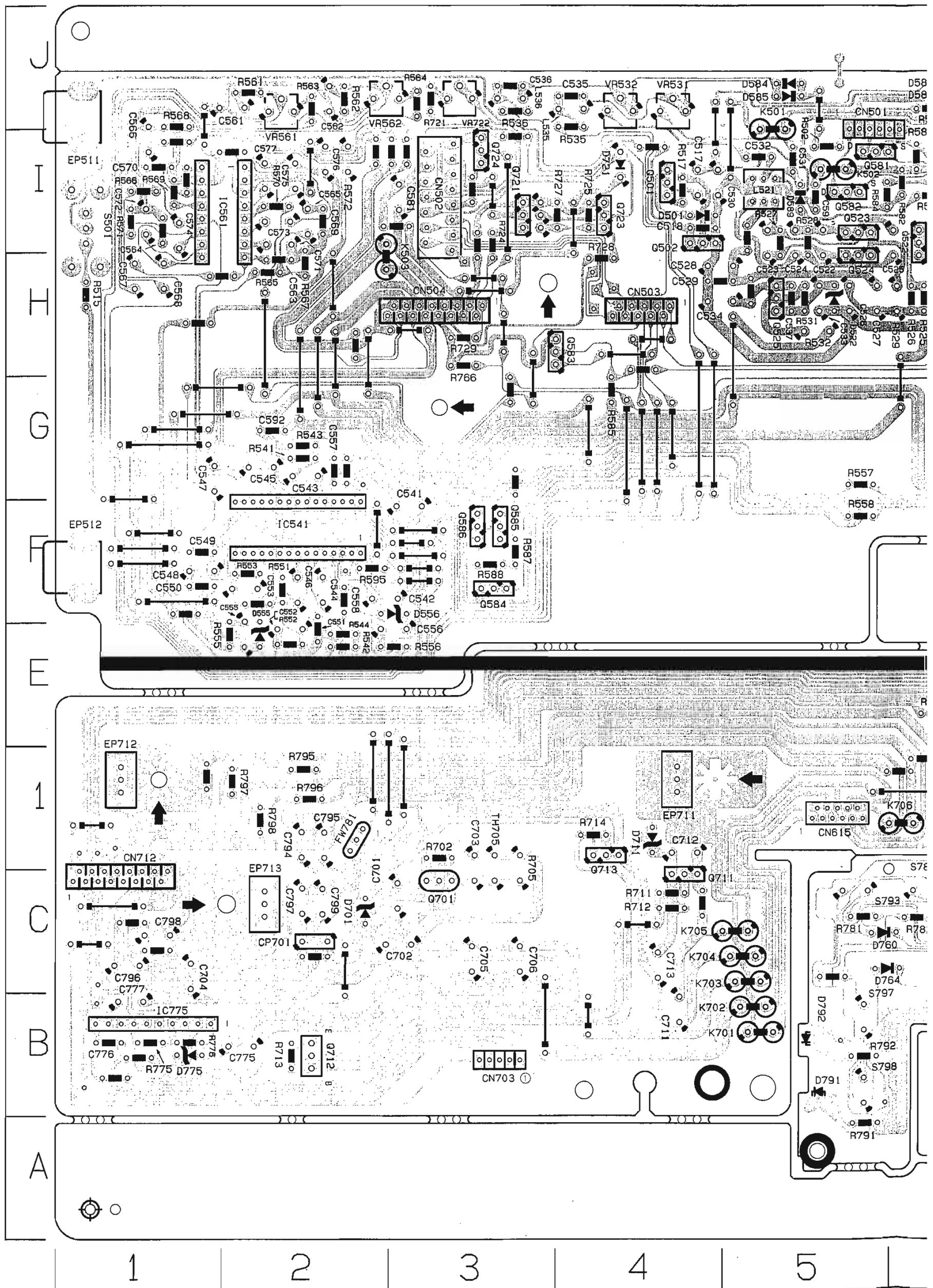

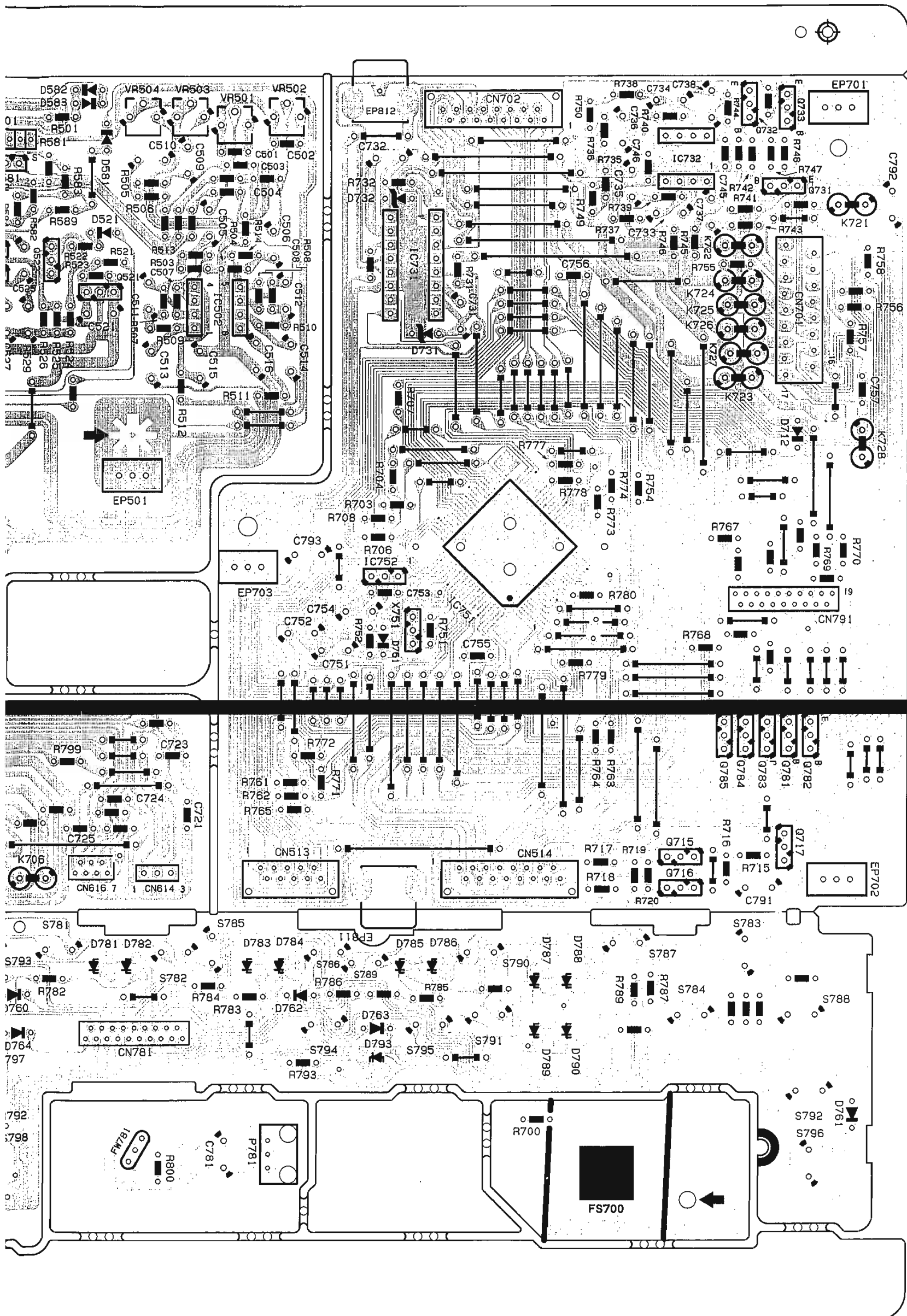

6

7

8

9

10

■ Location List (ENJ-099)

Symbol	X	Y	Symbol	X	Y	Symbol	X	Y	Symbol	X	Y	Symbol	X	Y	Symbol	X	Y
C501	7	I	C701	3	C	D712	10	G	Q717	10	D	R589	6	I	R782	6	C
C502	7	I	C702	3	C	D721	4	I	Q721	3	I	R595	2	F	R783	7	C
C503	7	I	C703	3	D	D731	8	H	Q722	3	I	R700	8	B	R784	6	C
C504	7	I	C704	1	C	D732	8	I	Q723	4	I	R702	3	D	R785	8	C
C505	7	I	C705	3	C	D751	7	F	Q724	3	I	R703	8	G	R786	7	C
C506	7	I	C706	3	C	D760	5	C	Q731	10	I	R704	8	G	R787	9	C
C507	6	H	C711	4	B	D761	10	B	Q732	10	J	R705	3	D	R789	9	C
C508	7	H	C712	4	D	D762	7	C	Q733	10	J	R706	8	F	R791	5	A
C509	6	I	C713	4	C	D763	7	C	Q781	10	E	R707	8	H	R792	5	B
C510	6	I	C721	6	D	D764	5	C	Q782	10	E	R708	8	G	R793	7	B
C511	6	H	C722	6	E	D775	1	B	Q783	10	E	R711	4	C	R795	2	D
C512	7	H	C723	6	E	D781	6	C	Q784	10	E	R712	4	C	R796	2	D
C513	6	H	C724	6	D	D782	6	C	Q785	9	E	R713	2	B	R797	2	D
C514	7	H	C725	6	D	D783	7	C	R501	6	J	R714	4	D	R798	2	D
C515	6	H	C731	8	H	D784	7	C	R502	5	I	R715	9	D	R799	6	E
C516	7	H	C732	8	I	D785	8	C	R503	7	I	R716	9	D	R800	6	B
C517	4	I	C733	9	I	D786	8	C	R504	7	I	R717	9	D	S501	1	I
C518	4	I	C734	9	J	D787	8	C	R505	6	I	R718	9	D	S781	6	C
C521	6	H	C735	9	I	D788	9	C	R506	6	I	R719	9	D	S782	6	C
C522	5	H	C736	9	J	D789	8	C	R507	6	H	R720	9	D	S783	10	C
C523	5	H	C737	9	I	D790	9	C	R508	7	H	R721	3	J	S784	9	C
C524	5	I	C738	9	J	D791	5	B	R509	6	H	R724	3	H	S785	7	C
C525	5	H	C745	9	I	D792	5	B	R510	7	H	R725	4	I	S786	7	C
C526	5	H	C746	9	I	D793	7	B	R511	7	H	R727	3	I	S787	9	C
C527	5	H	C751	7	F	IC502	6	H	R512	6	H	R728	4	H	S788	10	C
C528	5	H	C752	7	F	IC541	2	F	R513	6	I	R729	3	H	S789	7	C
C529	5	H	C753	7	F	IC561	2	I	R514	7	I	R731	8	H	S790	8	C
C530	4	I	C754	7	F	IC731	8	I	R515	1	H	R732	7	I	S791	8	C
C531	5	I	C755	8	F	IC732	9	I	R517	4	I	R735	9	I	S792	10	B
C532	5	I	C756	9	H	IC751	8	F	R521	6	I	R736	9	J	S793	5	C
C533	5	H	C757	10	G	IC752	7	F	R522	6	I	R737	9	I	S794	7	C
C534	5	H	C775	2	B	IC775	1	B	R523	6	H	R738	9	J	S795	8	C
C535	3	J	C776	1	B	K501	5	I	R524	6	H	R739	9	I	S796	10	B
C536	3	J	C777	1	B	K502	5	I	R525	6	H	R740	9	J	S797	5	B
C537	5	H	C781	7	B	K503	2	H	R526	6	H	R741	9	I	S798	5	B
C541	3	F	C791	10	D	K701	5	B	R527	5	H	R742	10	I	TH705	3	D
C542	2	F	C792	10	I	K702	5	B	R528	5	I	R743	9	I	X751	8	F
C543	2	G	C793	7	F	K703	5	C	R529	5	H	R744	9	J			
C544	2	F	C794	2	D	K704	5	C	R531	5	H	R745	9	I			
C545	2	G	C795	2	D	K705	4	C	R532	5	H	R746	9	I			
C546	2	F	C796	1	C	K706	6	D	R535	3	J	R747	10	I			
C547	1	G	C797	2	C	K721	10	I	R536	3	J	R748	10	I			
C548	1	F	C798	1	C	K722	10	I	R541	2	G	R749	9	I			
C549	1	F	C799	2	C	K723	10	H	R542	2	E	R750	9	J			
C550	1	F	CN501	5	I	K724	10	H	R543	2	G	R751	8	F			
C551	2	F	CN502	3	I	K725	10	H	R544	2	E	R752	7	F			
C552	2	E	CN503	4	H	K726	10	H	R551	2	F	R754	9	G			
C553	2	F	CN504	3	H	K727	10	H	R552	2	E	R755	10	I			
C555	2	F	CN513	7	D	K728	10	G	R553	2	F	R756	10	H			
C556	3	E	CN514	8	D	L521	5	I	R555	2	E	R757	10	H			
C557	2	G	CN614	6	D	L535	3	J	R556	3	E	R758	10	I			
C558	2	F	CN615	5	D	L536	3	J	R557	5	G	R761	7	E			
C561	1	J	CN616	6	D	P781	7	B	R558	5	F	R762	7	D			
C562	2	J	CN701	10	I	Q501	4	I	R561	2	J	R763	9	E			
C563	2	H	CN702	8	J	Q502	4	I	R562	2	J	R764	9	E			
C564	1	I	CN703	3	B	Q521	6	H	R563	2	J	R765	7	D			
C565	2	I	CN712	1	C	Q522	6	H	R564	3	J	R766	3	H			
C566	1	I	CN781	6	C	Q523	5	I	R565	2	H	R767	9	F			
C567	1	H	CN791	9	F	Q524	5	H	R566	1	I	R768	9	F			
C568	1	H	D501	4	I	Q525	5	H	R567	2	H	R769	10	F			
C569	2	I	D521	6	I	Q581	5	I	R568	1	J	R770	10	F			
C570	1	I	D522	5	H	Q582	5	I	R569	1	I	R771	7	E			
C571	2	I	D555	2	E	Q583	3	H	R570	2	I	R772	7	E			
C572	1	I	D556	2	F	Q584	3	F	R571	1	I	R773	9	G			
C573	2	I	D581	6	I	Q585	3	F	R572	2	I	R774	9	G			
C574	1	I	D582	6	J	Q586	3	F	R581	6	I	R775	1	B			
C575	2	I	D583	6	J	Q701	3	C	R582	6	I	R776	1	B			
C576	2	I	D584	5	J	Q711	4	C	R583	6	I	R777	9	G			
C577	2	I	D585	5	J	Q712	2	B	R584	5	I	R778	9	G			
C581	3	I	D589	5	I	Q713	4	D	R585	4	G	R779	9	F			
C591	5	I	D701	2	C	Q715	9	D	R587	3	F	R780	9	F			
C592	2	G	D711	4	D	Q716	9	D	R588	3	F	R781	5	C			

CD Mech. Control & Servo P.C.Board

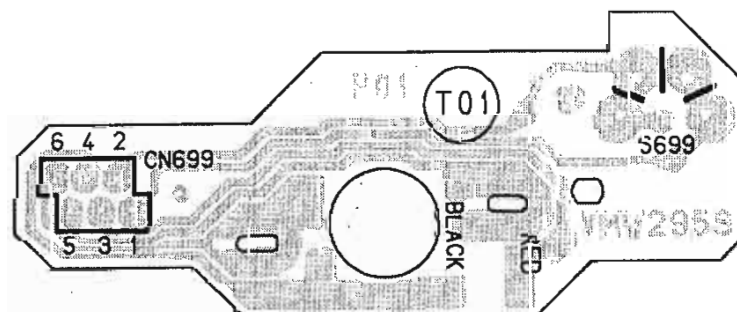
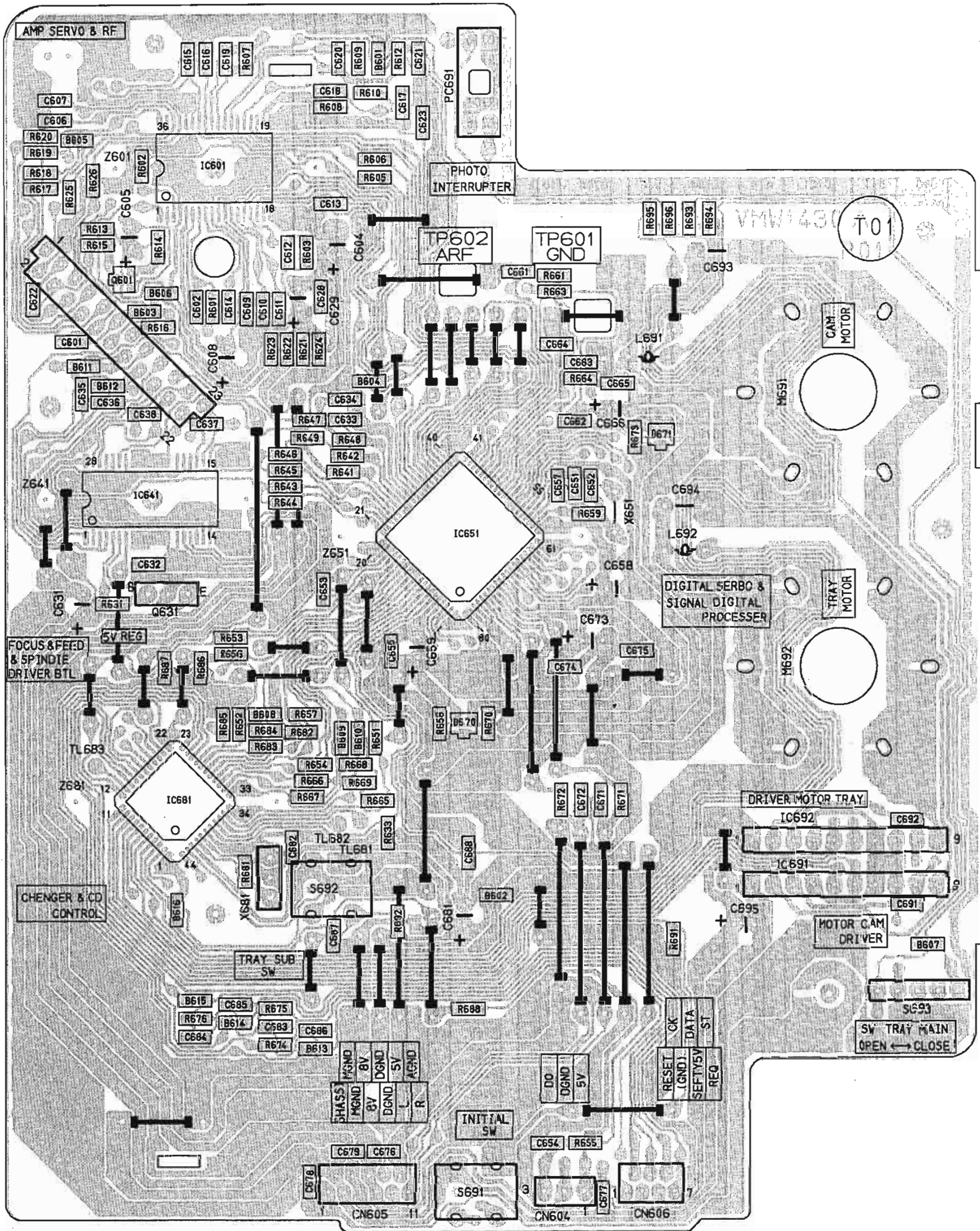

PARTS LIST

<RX-TD5/TD55R>

* All printed circuit boards and its assemblies are not available as service parts.

The Marks for Designated Areas

BS ---- the U.K.
 C ---- Canada
 EF ---- Continental Europe
 EN ---- Scandinavia
 G ---- Germany
 J ---- the U.S.A.
 UB ---- Hong Kong
 U ---- Universal Type
 UP ---- Korea
 US ---- Singapore
 UT ---- Taiwan
 VX ---- East Europe
 No marks indicates all areas.

- Contents -

General Exploded View and Parts List	-----	4-2
Electrical Parts List	-----	4-5
(ENH-307M)	-----	4-5
(ENB-253M)	-----	4-8
(ENA-178AM)	-----	4-10
(ENA-178BM/178CM)	-----	4-11
(ENA-178DM)	-----	4-12
(ENA-178EM)	-----	4-13

RX-TD5/RX-TD55R

General Exploded View and Parts List

Block No. **M T M M**

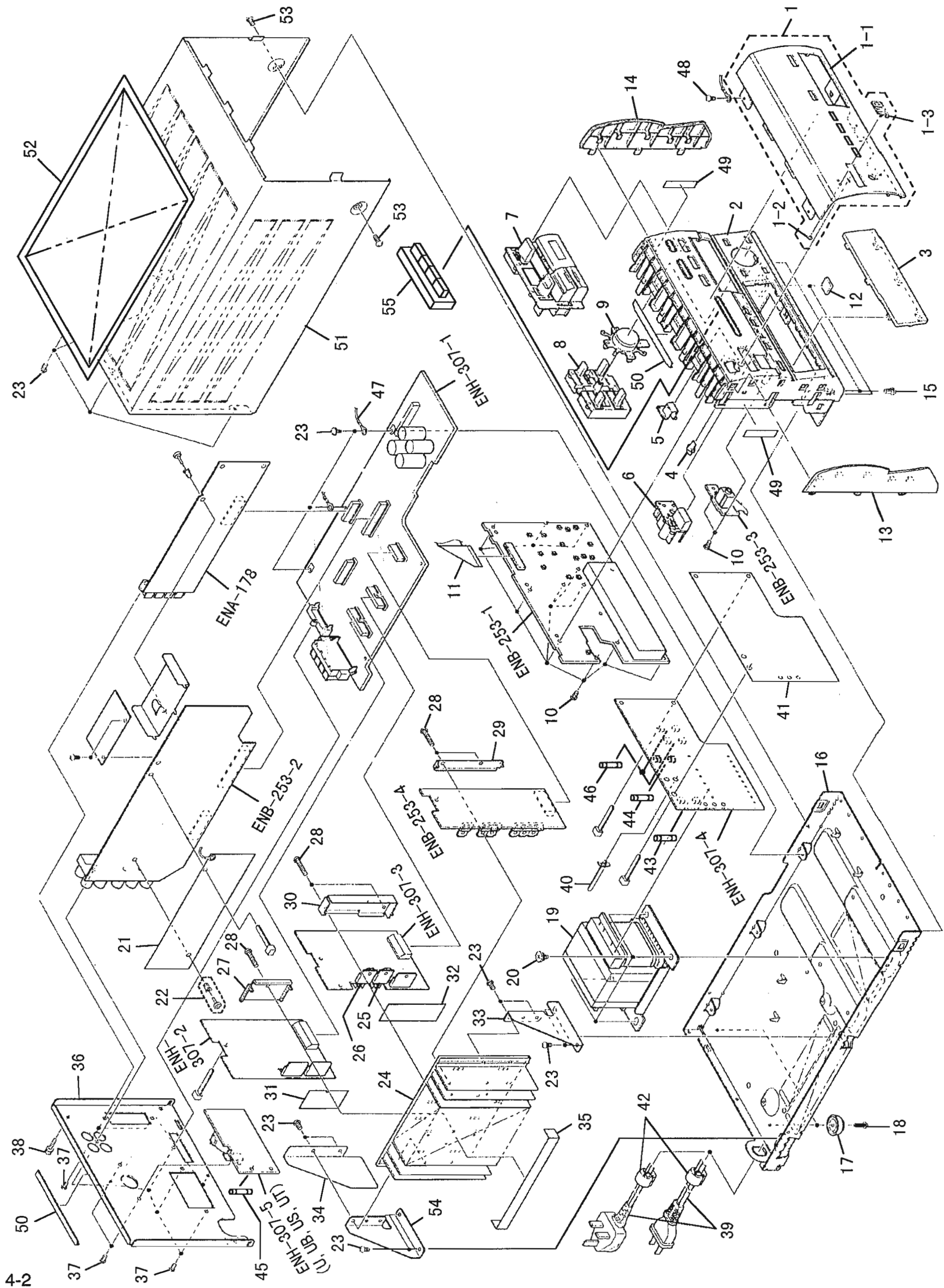

■ Parts List (RX-TD5)

Block No. **M1M1M1**

△	Item	Parts Number	Parts Name	Q'ty	Description	Area
	1	EFP-RXTD5E(S)	FRONT PANEL ASSY	1		C J U UB UP US UT
		EFP-RXTD5U(S)	FRONT PANEL ASSY	1		BS EF EN G VX
	1-1	LE20087-001A	FRONT PANEL	1		C J U UB UP US UT
		LE20087-005A	FRONT PANEL	1		BS EF EN G VX
	1-2	E60912-003	SPEED NUT	1		
	1-3	E406971-221	JVC MARK	1		
	2	LE10062-001A	FRONT BASE	1		
	3	LE20094-001A	WINDOW SCREEN	1		
	4	LE40119-002A	INDICATOR	1		
	5	LE40120-001A	REMOTE LENS	1		
	6	LE30326-001A	POWER BUTTON	1		C J U UB UP US UT
		LE30326-002A	POWER BUTTON	1		BS EF EN G VX
	7	LE20089-003A	PUSH BUTTON ASSY	1		
	8	LE20092-001A	PUSH BUTTON	1		
	9	LE20093-001A	PUSH BUTTON	1		
	10	SDSF2608Z	SCREW	13		
	11	VWF1227-25TTB	FLAT WIRE	1		
	12	E75896-001	SPACER	2		
	13	LE20098-001A	SIDE FITTING	1		
	14	LE20099-001A	SIDE FITTING	1		
	15	SDSG3006CC	SCREW	2		
	16	LE10064-003A	CHASSIS BASE	1		
	17	E47227-029	FOOT	2		
	18	SBSG3008Z	TAPPING SCREW	2		
△	19	QQT0165-001	POWER TRANSFORMER	1		C J
△		QQT0165-002	POWER TRANSFORMER	1		BS EF EN G VX
△		QQT0165-003	POWER TRANSFORMER	1		U UB UP US UT
	20	E65389-002	SPECIAL SCREW	4		
	21	LE30475-202A	SHIELD PLATE ASSY	1		U UB US UT
	22	E310243-002	PLASTIC RIVET	1		U UB US UT
	23	SBSG3008CC	TAPPING SCREW	15		
	24	LE30333-003A	HEAT SINK	1		
	25	2SC4466LD/Y/	SI. TRANSISTOR	1	Q1007	
	26	2SA1693LD/Y/	SI. TRANSISTOR	1	Q1008	
	27	FMKL4007-001	BRACKET	1		
	28	SBSG3014Z	TAPPING SCREW	5		
	29	E407434-001SM	LEAF SPRING	1		
	30	LE40125-001A	BRACKET	1		
	31	FMPK4003-001	MICA SHEET	1		
	32	LE40124-002A	MICA SHEET	1		
	33	LE30334-001A	HEAT SINK BRACKET	1		
	34	LE40265-001A	PROTECTOR COVER	1		
	35	EX0150010H09S11	FELT SPACER	1		
	36	LE20095-013A	REAR PANEL	1		J
		LE20095-014A	REAR PANEL	1		C
		LE20095-015A	REAR PANEL	1		BS EF EN G
		LE20095-016A	REAR PANEL	1		VX
		LE20095-017A	REAR PANEL	1		U UB US UT
		LE20095-018A	REAR PANEL	1		UP
	37	E73273-003	SPECIAL SCREW	7		J C BS EF EN G VX UP
		E73273-003	SPECIAL SCREW	9		U UB US UT
	38	E409257-001	GND TERMINAL	1		
△	39	EMP7000-200	POWER CORD	1		UP
△		QMP1400-244	POWER CORD	1		C J

RX-TD5/RX-TD55R

■ Parts List (RX-TD5)

Block No. **M1M1M1**

△	Item	Parts Number	Parts Name	Q'ty	Description	Area
△	39	QMP39E0-200	POWER CORD	1		EF EN G US VX
△		QMP5530-0085BS	POWER CORD	1		BS UB
△		QMP7520-200	POWER CORD	1		U UT
	40	E307572-001	FASTENER	1		
	41	LE30476-201A	PROTECT SHEET	1		
△	42	QHS3876-162	CORD STOPPER	1		Except C and J
△		QHS3876-163	CORD BUSHING	1		C J
△	43	QMF0007-2R0J1	FUSE	1	F001 (T2.0A/125V)	C J
△		QMF51E2-1R0J1	FUSE	1	F001 (T1.0A/250V)	EF EN G VX BS
△	44	QMF51E2-1R0J1	FUSE	1	F002 (T1.0A/250V)	UP
△		QMF51E2-2R0	FUSE	1	F002 (T2.0A/250V)	U UB US UT
△	45	QMF51E2-1R0J1	FUSE	1	F003 (T1.0A/250V)	U UB US UT
△	46	QMF0007-4R0J1	FUSE	2	F101, F102 (T4.0A/125V)	C J
△		QMF51E2-4R0	FUSE	2	F101, F102 (T4.0A/250V)	Except C and J
	47	EWT025-006	TERMINAL WIRE	1		
	48	SDSG3008Z	SCREW	1		
	49	LE30001-016A	SPACER	2		
	50	LE30001-017A	SPACER	2		
	51	LE20097-001A (S)	METAL COVER	1		BS C EF EN G J VX
		LE20097-003A (S)	METAL COVER	1		U UB UP US UT
	52	LE30336-001A	PROTECT SHEET	1		U UB UP US UT
	53	SDSG3006N	TAPPING SCREW	2		
	54	LE30335-001A	HEAT SINK BRACKET	1		
	-	E309551-005	RATING LABEL	1		VX
		LE40210-001A	CAUTION LABEL	1		UT

■ Parts List (RX-TD55R)

* Please see the parts list of RX-TD5 for parts which are not described.

△	Item	Parts Number	Parts Name	Q'ty	Description	Area
	1	EFP-RXTD55RE (S)	FRONT PANEL ASSY	1		
	1-1	LE20087-002A	FRONT PANEL	1		
	36	LE20095-023A	REAR PANEL	1		
△	39	QMP3900-200	POWER CORD	1		
	55	LE30331-001A	PUSH BUTTON	1	RDS	

■ Electrical Parts List (ENH-307M)

△	Item	Parts Number	Description	Area
		I. C. S		
	IC301	TDA7294	I. C (M)	
	IC302	BA15218N	I. C (MONO-ANALOG)	
	IC351	TDA7294	I. C (M)	
	IC352	TDA7294	I. C (M)	
		DIODES		
△	D201	1N5402M-20	DIODE	
△	D202	1N5402M-20	DIODE	
△	D203	1N5402M-20	DIODE	
△	D204	1N5402M-20	DIODE	
△	D205	30DL2FC	SI. DIODE	
△	D206	30DL2FC	SI. DIODE	
△	D207	30DL2FC	SI. DIODE	
△	D208	30DL2FC	SI. DIODE	
	D209	1SR35-100	SI. DIODE	
	D210	1SR35-100	SI. DIODE	
	D211	1SR35-100	SI. DIODE	
	D212	MTZ33JC	ZENER DIODE	
	D213	MTZ5.6JC	ZENER DIODE	
	D214	1SS133	SI. DIODE	
	D215	MTZ5.1JB	ZENER DIODE	
	D216	1SS133	SI. DIODE	
	D217	1SS133	SI. DIODE	
	D241	1SS133	SI. DIODE	
	D242	1SS133	SI. DIODE	
	D319	1SS133	SI. DIODE	
	D371	1SS133	SI. DIODE	
	D372	1SS133	SI. DIODE	
	D381	1SS133	SI. DIODE	
△	D1009	30DL2FC	SI. DIODE	
△	D1010	30DL2FC	SI. DIODE	
	D1011	1SS133	SI. DIODE	
	D1013	1SS133	SI. DIODE	
	D1015	1SS133	SI. DIODE	
	D1016	1SS133	SI. DIODE	
	D1017	MTZ3.9JB	ZENER DIODE	
	D1018	MTZ3.9JB	ZENER DIODE	
	D1019	1SS133	SI. DIODE	
	D1020	1SS133	SI. DIODE	
	D1021	1SS133	SI. DIODE	
	D1022	1SS133	SI. DIODE	
		TRANSISTORS		
	Q201	2SA934 (Q, R)	SI. TRANSISTOR	
	Q202	KRC107M-T	DIGITAL TRANSISTOR	
	Q203	KRC107M-T	DIGITAL TRANSISTOR	
	Q204	KRC107M-T	DIGITAL TRANSISTOR	
	Q221	2SD2144S (VW)	SI. TRANSISTOR	
	Q222	2SD2144S (VW)	SI. TRANSISTOR	
	Q223	KRA111M-T	DIGITAL TRANSISTOR	
	Q241	KRA107M-T	DIGITAL TRANSISTOR	
	Q242	2SC1775AV (F1)	SI. TRANSISTOR	
	Q301	2SA1038 (R, S)	SI. TRANSISTOR	
	Q371	2SA1038 (R, S)	SI. TRANSISTOR	
	Q372	2SA1038 (R, S)	SI. TRANSISTOR	
	Q381	2SC2389 (S, E)	SI. TRANSISTOR	
	Q382	2SA1038 (R, S)	SI. TRANSISTOR	
	Q383	2SC1740S (R, S)	SI. TRANSISTOR	
	Q389	KRA104M-T	DIGITAL TRANSISTOR	
	Q390	2SK301 (P, Q)	F. E. T.	
	Q1001	2SC1685	SI. TRANSISTOR	
	Q1002	2SA933S (RS)	SI. TRANSISTOR	
	Q1003	2SC1685	SI. TRANSISTOR	
	Q1004	2SA733A (P, K)	SI. TRANSISTOR	
	Q1005	2SA965 (Y)	SI. TRANSISTOR	
	Q1006	2SC2235 (O, Y)	SI. TRANSISTOR	
		CAPACITORS		
	C201	QFV82AJ-104	0.1MF 100V THIN FILM CA	
	C202	QFV72AJ-103ZM	0.01MF 100V THIN FILM CA	C J U UB UP US UT
		QFV82AJ-104	0.1MF 100V THIN FILM CA	BS EF EN G VX
	C203	QFV72AJ-103ZM	0.01MF 100V THIN FILM CA	C J U UB UP US UT
		QFV82AJ-104	0.1MF 100V THIN FILM CA	BS EF EN G VX
	C204	QFV81HJ-104	0.1MF 50V THIN FILM CA	
	C205	QFV81HJ-103	0.01MF 50V THIN FILM CA	C J U UB UP US UT
		QFV81HJ-104	0.1MF 50V THIN FILM CA	BS EF EN G VX
	C206	QFV81HJ-103	0.01MF 50V THIN FILM CA	C J U UB UP US UT
		QFV81HJ-104	0.1MF 50V THIN FILM CA	BS EF EN G VX
	C207	QETB1JM-107	100MF 63V AL. E. CAP.	
	C208	QETB1JM-476	47MF 63V AL. E. CAP.	
	C209	QETB1HM-226E	22MF 50V E. CAP.	
	C210	QCVB1CM-103Y	0.01MF 16V CER. CAP.	
	C211	QETB1HM-226E	22MF 50V E. CAP.	
	C212	QETB1HM-475E	4.7MF 50V E. CAP.	
	C213	QETM1HM-228	2200MF 50V E. CAP.	C J
		QETM1HM-338	3300MF 50V E. CAP.	Except C and J
	C214	QETM1HM-228	2200MF 50V E. CAP.	C J
		QETM1HM-338	3300MF 50V E. CAP.	Except C and J
	C215	QETB1VM-338	3300MF 35V AL. E. CAP.	C J
		QETB1VM-478N	4700MF 35V AL. E. CAP.	Except C and J
	C216	QETB1VM-338	3300MF 35V AL. E. CAP.	C J
		QETB1VM-478N	4700MF 35V AL. E. CAP.	Except C and J
	C217	QETB1HM-225	2.2MF 50V AL. E. CAP.	
	C218	QETB1HM-105	1MF 50V AL. E. CAP.	
	C219	QCHB1EZ-223	0.022MF 25V CER. CAP.	BS EF EN G VX
	C222	QCZO202-155	1.5MF 25V CER. RES.	
	C231	QETB1CM-476	47MF 16V AL. E. CAP.	
	C232	QETB1CM-476	47MF 16V AL. E. CAP.	
	C234	QFLB1HJ-103	0.01MF 50V MYLAR CAP.	
	C241	QCHB1EZ-223	0.022MF 25V CER. CAP.	BS EF EN G VX
	C242	QCHB1EZ-223	0.022MF 25V CER. CAP.	BS EF EN G VX
	C243	QFLB1HJ-473	0.047MF 50V MYLAR CAP.	
	C244	QFLB1HJ-473	0.047MF 50V MYLAR CAP.	
	C245	QCHB1EZ-223	0.022MF 25V CER. CAP.	BS EF EN G VX
	C246	QFLB1HJ-473	0.047MF 50V MYLAR CAP.	
	C247	QFLB1HJ-393	0.039MF 50V MYLAR CAP.	BS EF EN G VX
	C248	QFLB1HJ-393	0.039MF 50V MYLAR CAP.	BS EF EN G VX
	C249	QFLB1HJ-393	0.039MF 50V MYLAR CAP.	BS EF EN G VX
	C300	QFV81HJ-103	0.01MF 50V THIN FILM CA	
	C301	EETB1HM-105E	1MF 50V E. CAP.	
	C303	QCBB1HK-101Y	100PF 50V CER. CAP.	
	C305	QCBB1HK-101Y	100PF 50V CER. CAP.	
	C307	QETB1EM-476	47MF 25V AL. E. CAP.	
	C309	QCSB1HJ-100Y	10PF 50V CER. CAP.	
	C311	QETB1HM-226E	22MF 50V E. CAP.	
	C319	QFLB1HJ-104	0.1MF 50V MYLAR CAP.	Except J
		QFLB1HJ-473	0.047MF 50V MYLAR CAP.	J
	C320	QFLB1HJ-104	0.1MF 50V MYLAR CAP.	Except J
	C350	QFV81HJ-103	0.01MF 50V THIN FILM CA	
	C351	EETB1HM-105E	1MF 50V E. CAP.	
	C352	EETB1HM-105E	1MF 50V E. CAP.	
	C353	QCBB1HK-101Y	100PF 50V CER. CAP.	
	C354	QCBB1HK-101Y	100PF 50V CER. CAP.	
	C355	QFV82AJ-104	0.1MF 100V THIN FILM CA	
	C359	QCBB1HK-101Y	100PF 50V CER. CAP.	
	C360	QCBB1HK-101Y	100PF 50V CER. CAP.	
	C361	QETB1HM-226E	22MF 50V E. CAP.	
	C362	QETB1HM-226E	22MF 50V E. CAP.	
	C363	QETB1EM-476	47MF 25V AL. E. CAP.	
	C364	QETB1EM-476	47MF 25V AL. E. CAP.	
	C365	QCSB1HJ-100Y	10PF 50V CER. CAP.	
	C366	QCSB1HJ-100Y	10PF 50V CER. CAP.	
	C367	QFLB1HJ-104	0.1MF 50V MYLAR CAP.	Except J
		QFLB1HJ-473	0.047MF 50V MYLAR CAP.	J
	C368	QFLB1HJ-104	0.1MF 50V MYLAR CAP.	Except J
		QFLB1HJ-473	0.047MF 50V MYLAR CAP.	J

RX-TD5/RX-TD55R

■ Electrical Parts List (ENH-307M)

△	Item	Parts Number	Description	Area
	C369	QFLB1HJ-104	0.1MF 50V MYLAR CAP.	Except J
	C370	QFLB1HJ-104	0.1MF 50V MYLAR CAP.	Except J
	C381	QETB1EM-106	10MF 25V AL E. CAP.	
	C382	QETB1CM-476	47MF 16V AL E. CAP.	
	C389	QFV71HJ-184ZM	0.18MF 50V CAP.	
	C390	QER51HM-475	4.7MF 50V AL E. CAP.	
	C1005	QCXB1CM-272Y	2700PF 16V CER. CAP.	
	C1006	QCXB1CM-272Y	2700PF 16V CER. CAP.	
	C1007	QCXB1CM-472Y	4700PF 16V CER. CAP.	
	C1008	QCXB1CM-472Y	4700PF 16V CER. CAP.	
	C1009	QFV81HJ-105	1MF 50V THIN FILM CA	
	C1010	QFV81HJ-105	1MF 50V THIN FILM CA	
	C1011	QCGB1HK-102	1000PF 50V CER. CAP.	
	C1012	QCGB1HK-102	1000PF 50V CER. CAP.	
	C1013	QFLB1HJ-104	0.1MF 50V MYLAR CAP.	
	C1014	QFLB1HJ-104	0.1MF 50V MYLAR CAP.	
	C1017	QCGB1HK-102	1000PF 50V CER. CAP.	
	C1018	QCGB1HK-102	1000PF 50V CER. CAP.	
		RESISTORS		
△	R001	QRZ9044-335	3.3M COMPOSITION	C J
	R002	QRD161J-104	100K 1/6W CARBON RES.	U UB US UT
	R003	QRD161J-104	100K 1/6W CARBON RES.	U UB US UT
	R004	QRD161J-104	100K 1/6W CARBON RES.	U UB US UT
△	R202	QRD14CJ-4R7SX	4.7 1/4W UNF. CARBON R	J
	R203	QRD161J-362	3.6K 1/6W CARBON RES.	
	R204	QRD161J-104	100K 1/6W CARBON RES.	
△	R205	QRD14CJ-1R0SX	1 1/4W UNF. CARBON R	
△	R206	QRD14CJ-1R0SX	1 1/4W UNF. CARBON R	
	R207	QRD161J-103	10K 1/6W CARBON RES.	
	R208	QRD161J-103	10K 1/6W CARBON RES.	
	R209	QRD161J-102	1K 1/6W CARBON RES.	
	R210	QRD161J-104	100K 1/6W CARBON RES.	
	R212	QRD161J-104	100K 1/6W CARBON RES.	
△	R221	QRD14CJ-271S	270 1/4W UNF. CARBON R	
△	R222	QRD14CJ-271S	270 1/4W UNF. CARBON R	
△	R223	QRD14CJ-681SX	680 1/4W UNF. CARBON R	
△	R224	QRD14CJ-681SX	680 1/4W UNF. CARBON R	
	R225	QRD161J-472	4.7K 1/6W CARBON RES.	
	R226	QRD161J-472	4.7K 1/6W CARBON RES.	
	R227	QRD161J-0R0	0 1/6W CARBON RES.	
	R231	QRD161J-104	100K 1/6W CARBON RES.	
	R232	QRD161J-104	100K 1/6W CARBON RES.	
	R233	QRD161J-104	100K 1/6W CARBON RES.	
	R240	QRD161J-473	47K 1/6W CARBON RES.	
	R241	QRD167J-152	1.5K 1/6W CARBON RES.	
	R242	QRD161J-473	47K 1/6W CARBON RES.	
△	R244	QRG01DJ-561X	560 1W OXIDE METAL	
△	R245	QRG01DJ-561X	560 1W OXIDE METAL	
△	R247	QRD14CJ-100SX	10 1/4W UNF. CARBON R	
△	R248	QRD14CJ-100SX	10 1/4W UNF. CARBON R	
△	R249	QRD14CJ-100SX	10 1/4W UNF. CARBON R	
	R301	QRD161J-102	1K 1/6W CARBON RES.	
△	R302	QRD14CJ-4R7SX	4.7 1/4W UNF. CARBON R	
	R303	QRD161J-753	75K 1/6W CARBON RES.	
△	R305	QRD14CJ-102SX	1K 1/4W UNF. CARBON R	
	R307	QRD161J-753	75K 1/6W CARBON RES.	
△	R309	QRX014J-R22	0.22 1W METAL FILM R	
△	R311	QRX014J-R22	0.22 1W METAL FILM R	
	R312	QRD161J-222	2.2K 1/6W CARBON RES.	U UB UP US UT
△	R313	QRD14CJ-100SX	10 1/4W UNF. CARBON R	
△	R315	QRD14CJ-2R2SX	2.2 1/4W UNF. CARBON R	
	R317	QRD161J-122	1.2K 1/6W CARBON RES.	
	R319	QRD167J-223	22K 1/6W CARBON RES.	
	R320	QRD161J-103	10K 1/6W CARBON RES.	
△	R321	QRD14CJ-4R7SX	4.7 1/4W UNF. CARBON R	J
△		QRZ0077-4R7	4.7 1/4W FUSE RESISTO	Except J
△	R322	QRD14CJ-4R7SX	4.7 1/4W UNF. CARBON R	J

△	Item	Parts Number	Description	Area
△	R322	QRZ0077-4R7	4.7 1/4W FUSE RESISTO	Except J
	R323	QRD161J-473	47K 1/6W CARBON RES.	
	R351	QRD161J-102	1K 1/6W CARBON RES.	
	R352	QRD161J-102	1K 1/6W CARBON RES.	
	R353	QRD161J-393	39K 1/6W CARBON RES.	
	R354	QRD161J-393	39K 1/6W CARBON RES.	
△	R355	QRX014J-R22	0.22 1W METAL FILM R	
△	R356	QRX014J-R22	0.22 1W METAL FILM R	
△	R357	QRX014J-R22	0.22 1W METAL FILM R	
△	R358	QRX014J-R22	0.22 1W METAL FILM R	
△	R359	QRD14CJ-100SX	10 1/4W UNF. CARBON R	
△	R360	QRD14CJ-100SX	10 1/4W UNF. CARBON R	
△	R363	QRD14CJ-821SX	820 1/4W CARBON RES.	
△	R364	QRD14CJ-821SX	820 1/4W CARBON RES.	
	R365	QRD161J-393	39K 1/6W CARBON RES.	
	R366	QRD161J-393	39K 1/6W CARBON RES.	
△	R367	QRD14CJ-2R2SX	2.2 1/4W UNF. CARBON R	
△	R368	QRD14CJ-2R2SX	2.2 1/4W UNF. CARBON R	
	R371	QRD161J-473	47K 1/6W CARBON RES.	
	R372	QRD161J-473	47K 1/6W CARBON RES.	
	R373	QRD161J-122	1.2K 1/6W CARBON RES.	
	R374	QRD161J-122	1.2K 1/6W CARBON RES.	
	R375	QRD167J-223	22K 1/6W CARBON RES.	
	R376	QRD167J-223	22K 1/6W CARBON RES.	
	R377	QRD161J-103	10K 1/6W CARBON RES.	
	R378	QRD161J-103	10K 1/6W CARBON RES.	
	R379	QRD161J-104	100K 1/6W CARBON RES.	
	R380	QRD161J-823	82K 1/6W CARBON RES.	
	R381	QRD161J-103	10K 1/6W CARBON RES.	
	R382	QRD161J-103	10K 1/6W CARBON RES.	
	R383	QRD161J-104	100K 1/6W CARBON RES.	
	R384	QRD161J-104	100K 1/6W CARBON RES.	
	R389	QRD161J-182	1.8K 1/6W CARBON RES.	
	R390	QRD161J-105	1M 1/6W CARBON RES.	
	R391	QRD161J-102	1K 1/6W CARBON RES.	
	R392	QRD161J-123	12K 1/6W CARBON RES.	
	R393	QRD161J-273	27K 1/6W CARBON RES.	
	R396	QRD161J-475	4.7M 1/6W CARBON RES.	
	R1001	QRD167J-223	22K 1/6W CARBON RES.	
	R1002	QRD167J-223	22K 1/6W CARBON RES.	
	R1003	QRD167J-223	22K 1/6W CARBON RES.	
	R1004	QRD167J-223	22K 1/6W CARBON RES.	
	R1005	QRD161J-221	220 1/6W CARBON RES.	
	R1006	QRD161J-221	220 1/6W CARBON RES.	
	R1007	QRD161J-222	2.2K 1/6W CARBON RES.	
	R1008	QRD161J-222	2.2K 1/6W CARBON RES.	
	R1009	QRD161J-222	2.2K 1/6W CARBON RES.	
	R1010	QRD161J-222	2.2K 1/6W CARBON RES.	
	R1011	QRD167J-223	22K 1/6W CARBON RES.	
	R1012	QRD167J-223	22K 1/6W CARBON RES.	
	R1013	QRD167J-682	6.8K 1/6W CARBON RES.	
	R1014	QRD167J-682	6.8K 1/6W CARBON RES.	
△	R1015	QRD14CJ-681SX	680 1/4W UNF. CARBON R	
△	R1016	QRD14CJ-681SX	680 1/4W UNF. CARBON R	
△	R1017	QRD14CJ-821SX	820 1/4W CARBON RES.	
△	R1018	QRD14CJ-821SX	820 1/4W CARBON RES.	
	R1019	QRD161J-821	820 1/6W CARBON RES.	
	R1020	QRD161J-821	820 1/6W CARBON RES.	
	R1021	QRD161J-182	1.8K 1/6W CARBON RES.	
	R1022	QRD161J-182	1.8K 1/6W CARBON RES.	
△	R1027	QRD14CJ-101S	100 1/4W UNF. CARBON R	
		OTHERS		
		EMW10706-004	PRINTED BOARD	
	J201	QNB0034-001	SPEAKER TERMINAL	
	K214	ENZ8101-007	INDUCTOR	BS EF EN G VX
	L204	EGL4004-2R2	INDUCTOR	
	L301	EGL0011-R45J1	INDUCTOR	

■ Electrical Parts List (ENH-307M)

△	Item	Parts Number	Description	Area
	L351	EQL0011-R45J1	INDUCTOR	
	L352	EQL0011-R45J1	INDUCTOR	
△	S001	QSW0524-001	LEVER SWITCH	U UB US UT
△	CL001	E75803-002	CAUTION LABEL	J
△		E75804-002	CAUTION LABEL	C
	CN001	EMV7127-017	CONNECT TERMINAL	
	CN101	EMV7163-012	CONNECT TERMINAL	
	CN202	EMV7145-003Z	SOCKET ASSY	
	CN261	EMV7163-009	CONNECT TERMINAL	
	CN302	EMV5163-010R	CONNECT TERMINAL	
	CN311	EMV7163-013	CONNECT TERMINAL	
	CN312	EMV7163-010	CONNECT TERMINAL	
	CN351	EMV5163-013R	CONNECT TERMINAL	
	CN411	EMV7163-016	CONNECT TERMINAL	
	CN412	EMV7163-020	CONNECT TERMINAL	
	CN811	VMC0163-027	CONNECT TERMINAL	
	EP201	EMZ4002-002Z	EARTH PLATE	
	EP202	EMZ4002-002Z	EARTH PLATE	
	FT001	EMG7331-003Z	FUSE CLIP	BS C EF EN G J VX
	FT002	EMG7331-003Z	FUSE CLIP	BS C EF EN G J VX
	FT003	EMG7331-003Z	FUSE CLIP	U UB UP US UT
	FT004	EMG7331-003Z	FUSE CLIP	U UB UP US UT
	FT005	EMG7331-003Z	FUSE CLIP	U UB US UT
	FT006	EMG7331-003Z	FUSE CLIP	U UB US UT
	FT101	EMG7331-003Z	FUSE CLIP	
	FT102	EMG7331-003Z	FUSE CLIP	
	FT103	EMG7331-003Z	FUSE CLIP	
	FT104	EMG7331-003Z	FUSE CLIP	
	FW201	EWR38D-20SS	FLAT WIRE	
	FW203	EWR37D-25SS	FLAT WIRE	
	FW204	EWR33D-16SS	CORD	
	JT891	EMV7145-003Z	SOCKET ASSY	
	JT892	EMV7145-003Z	SOCKET ASSY	
	PW001	EWT015-025	TERMINAL WIRE	
	PW003	QWE884-32RR	VINYL WIRE	U UB US UT
	PW004	QWE883-36RR	VINYL WIRE	U UB US UT
	PW005	QWE882-32RR	VINYL WIRE	U UB US UT
	PW006	QWE881-36RR	VINYL WIRE	U UB US UT
	PW008	QWE886-36RR	VINYL WIRE	U UB US UT
	PW009	QWE888-36RR	VINYL WIRE	U UB US UT
	PW010	QWE880-08RR	VINYL WIRE	UP
	RY241	ESK7D24-2120	RELAY	
	RY242	ESK7D24-2120	RELAY	
	TB001	EMZ4001-002Z	TAB	
	TB002	EMZ4001-002Z	TAB	
△	TH202	QAD0095-4R7Z	POSITIVE THERMISTOR	Except J

RX-TD5/RX-TD55R

■ Electrical Parts List (ENB-253M)

* Only for RX-TD55R

△	Item	Parts Number	Description	Area
		I. C. S		
	IC401	HD404019RC87FS	I. C (MICRO-COMPUTER)	
	IC402	TDA7439	I. C (M)	
	IC404	LA2650	I. C (MONO-ANALOG)	
	IC801	MN173222JAAY	I. C (MICRO-COMPUTER)	
	IC802	GP1U281X	INFRARED DETECT UNIT	
		DIODES		
	D251	MTZ11JC	ZENER DIODE	
	D252	MTZ5.1JB	ZENER DIODE	
	D253	MTZ13JC	ZENER DIODE	
	D254	MTZ13JC	ZENER DIODE	
	D255	MTZ13JC	ZENER DIODE	
	D405	MTZ9.1JC	ZENER DIODE	
	D406	1SS133	SI. DIODE	
	D412	1SS133	SI. DIODE	
	D413	1SS133	SI. DIODE	
	D416	1SS133	SI. DIODE	
	D800	1SS133	SI. DIODE	
	D802	1SR35-100	SI. DIODE	
	D803	1SS133	SI. DIODE	
	D805	1SS133	SI. DIODE	U UB UP US UT VX
	D806	1SS133	SI. DIODE	C J VX
	*D808	1SS133	SI. DIODE	
	D810	SLR-342DCA47	L. E. D.	
	D811	SLR-342DCA47	L. E. D.	
	D812	SLR-342DCA47	L. E. D.	
	D813	SLR-342DCA47	L. E. D.	
	D814	SLR-342DCA47	L. E. D.	
	D815	SLR-342DCA47	L. E. D.	
	D816	SLR-342DCA47	L. E. D.	
	D817	SLR-342DCA47	L. E. D.	
	D818	SLA-380LT	L. E. D.	BS
		SLR-342VC3F	L. E. D.	Except BS
	D819	1SS133	SI. DIODE	
	D820	1SS133	SI. DIODE	
	D821	1SS133	SI. DIODE	
	D822	1SS133	SI. DIODE	
	*D823	1SS133	SI. DIODE	
		TRANSISTORS		
	Q251	2SD2061 (F, G)	SI. TRANSISTOR	
	Q252	2SD2061 (F, G)	SI. TRANSISTOR	
	Q253	2SC945A	SI. TRANSISTOR	
	Q254	2SC945A	SI. TRANSISTOR	
	Q255	2SD2061 (F, G)	SI. TRANSISTOR	
	Q256	2SD2061 (F, G)	SI. TRANSISTOR	
	Q257	2SC1740S (R, S)	SI. TRANSISTOR	
	Q259	2SD2061 (F, G)	SI. TRANSISTOR	
	Q261	2SC1740S (R, S)	SI. TRANSISTOR	
	Q262	KRC104M-T	DIGITAL TRANSISTOR	
	Q263	DTA114ES	DIGITAL TRANSISTOR	
	Q264	KRA104M-T	DIGITAL TRANSISTOR	
	Q265	DTC144ES	DIGITAL TRANSISTOR	
	Q266	2SB1565 (E, F)	SI. TRANSISTOR	
	Q401	2SD2144S (VW)	SI. TRANSISTOR	
	Q402	2SD2144S (VW)	SI. TRANSISTOR	
	Q403	KRA104M-T	DIGITAL TRANSISTOR	
	Q404	KRA107M-T	DIGITAL TRANSISTOR	
	Q405	2SD2144S (VW)	SI. TRANSISTOR	
	Q406	2SD2144S (VW)	SI. TRANSISTOR	
	Q409	KRC104M-T	DIGITAL TRANSISTOR	
	Q410	KRA104M-T	DIGITAL TRANSISTOR	
	Q411	KRA104M-T	DIGITAL TRANSISTOR	
	Q801	KRC102M-T	DIGITAL TRANSISTOR	
	Q802	KRC102M-T	DIGITAL TRANSISTOR	
	Q803	KRC102M-T	DIGITAL TRANSISTOR	
	Q804	KRC102M-T	DIGITAL TRANSISTOR	
	Q805	KRC111M-T	SI. TRANSISTOR	
	Q806	KRC111M-T	SI. TRANSISTOR	
	Q807	KRC111M-T	SI. TRANSISTOR	
		CAPACITORS		
	C252	QETB1CM-226	22MF 16V E. CAP.	
	C253	QCVB1CM-103Y	0.01MF 16V CER. CAP.	
	C254	QETB1CM-226	22MF 16V E. CAP.	
	C256	QETB1CM-476	47MF 16V AL. E. CAP.	

△	Item	Parts Number	Description	Area
	C257	QCVB1CM-103Y	0.01MF 16V CER. CAP.	
	C258	QETB1EM-106	10MF 25V AL. E. CAP.	
	C259	QETB1CM-226	22MF 16V E. CAP.	
	C260	QCVB1CM-103Y	0.01MF 16V CER. CAP.	
	C261	QETB1EM-106	10MF 25V AL. E. CAP.	
	C262	QETB1CM-476	47MF 16V AL. E. CAP.	
	C263	QCVB1CM-103Y	0.01MF 16V CER. CAP.	
	C264	QETB1EM-106	10MF 25V AL. E. CAP.	
	C265	QETB1CM-226	22MF 16V E. CAP.	
	C401	QCFB1HZ-104Y	0.1MF 50V CER. CAP.	U UB UP US UT
		QCHB1EZ-223	0.022MF 25V CER. CAP.	BS C EF EN G J VX
	C405	QCBB1HK-471Y	470PF 50V CER. CAP.	BS EF EN G VX
	C406	QCBB1HK-471Y	470PF 50V CER. CAP.	BS EF EN G VX
	C411	QFLB1HJ-272	2700PF 50V MYLAR CAP.	
	C412	QFLB1HJ-272	2700PF 50V MYLAR CAP.	
	C413	QFLB1HJ-183	0.018MF 50V MYLAR CAP.	
	C414	QFLB1HJ-183	0.018MF 50V MYLAR CAP.	
	C415	QFLB1HJ-223	0.022MF 50V MYLAR CAP.	
	C416	QFLB1HJ-223	0.022MF 50V MYLAR CAP.	
	C417	QFV81HJ-224	0.22MF 50V THIN FILM	
	C418	QFV81HJ-224	0.22MF 50V THIN FILM	
	C419	QFLB1HJ-563	0.056MF 50V MYLAR CAP.	
	C420	QFLB1HJ-563	0.056MF 50V MYLAR CAP.	
	C421	QETB1EM-106	10MF 25V AL. E. CAP.	
	C422	QETB1AM-477	470MF 10V E. CAP.	
	C423	QETB1EM-106	10MF 25V AL. E. CAP.	
	C424	QETB1EM-106	10MF 25V AL. E. CAP.	
	C425	QETB1EM-106	10MF 25V AL. E. CAP.	
	C426	QETB1EM-106	10MF 25V AL. E. CAP.	
	C427	QETB1EM-106	10MF 25V AL. E. CAP.	
	C428	QETB1EM-106	10MF 25V AL. E. CAP.	
	C429	QETB1EM-106	10MF 25V AL. E. CAP.	
	C430	QETB1EM-106	10MF 25V AL. E. CAP.	
	C431	QETB1HM-225	2.2MF 50V AL. E. CAP.	
	C432	QETB1HM-225	2.2MF 50V AL. E. CAP.	
	C433	QETB1EM-106	10MF 25V AL. E. CAP.	
	C434	QETB1EM-106	10MF 25V AL. E. CAP.	
	C447	QETB1EM-106	10MF 25V AL. E. CAP.	
	C448	QETB1EM-106	10MF 25V AL. E. CAP.	
	C449	QFLB1HJ-393	0.039MF 50V MYLAR CAP.	
	C450	QETB1HM-475E	4.7MF 50V E. CAP.	
	C451	QETB1HM-474	0.47MF 50V E. CAP.	
	C452	QFLB1HJ-393	0.039MF 50V MYLAR CAP.	
	C453	QETB1HM-475E	4.7MF 50V E. CAP.	
	C454	QFLB1HJ-393	0.039MF 50V MYLAR CAP.	
	C455	QFLB1HJ-393	0.039MF 50V MYLAR CAP.	
	C456	QETB1EM-476	47MF 25V AL. E. CAP.	
	C457	QETB1EM-106	10MF 25V AL. E. CAP.	
	C458	QETB1EM-106	10MF 25V AL. E. CAP.	
	C459	QETB1AM-477	470MF 10V E. CAP.	
	C460	QETB1HM-105	1MF 50V AL. E. CAP.	
	C461	QCZ0202-155	1.5MF 25V CER. RES.	
	C462	QCVB1CM-103Y	0.01MF 16V CER. CAP.	
	C463	QCFB1HZ-104Y	0.1MF 50V CER. CAP.	
	C464	QCVB1CM-103Y	0.01MF 16V CER. CAP.	
	C483	QETB1HM-475E	4.7MF 50V E. CAP.	
	C484	QEAD0HZ-479A	47000MF E. CAP.	
	C485	QETB0JM-107	100MF 6.3V AL. E. CAP.	
	C499	QCFB1HZ-104Y	0.1MF 50V CER. CAP.	
	C800	QCT25CH-220Z	22PF 50V CER. CAP.	
	C801	QCT25CH-220Z	22PF 50V CER. CAP.	
	C802	QCVB1CM-103Y	0.01MF 16V CER. CAP.	
	C803	QER50JM-107	100MF 6.3V AL. E. CAP.	
	C804	QCFB1HZ-104Y	0.1MF 50V CER. CAP.	
	C805	QEAD0HZ-479A	47000MF E. CAP.	
	C807	QCHB1EZ-223	0.022MF 25V CER. CAP.	
	C808	QETB0JM-107	100MF 6.3V AL. E. CAP.	
	C809	QER61HM-105Z	1MF 50V AL. E. CAP.	
	C810	QER61HM-105Z	1MF 50V AL. E. CAP.	
	C811	QCZ0202-155	1.5MF 25V CER. RES.	
	C812	QCBB1HK-151	150PF 50V CER. CAP.	
	C813	QCBB1HK-151	150PF 50V CER. CAP.	
	C814	QCZ0202-155	1.5MF 25V CER. RES.	
	C891	QCBB1HK-471Y	470PF 50V CER. CAP.	

■ Electrical Parts List (ENB-253M)

* Only for RX-TD55R

△	Item	Parts Number	Description	Area
	C892	QCBB1HK-471Y	470PF 50V CER. CAP.	
	C893	QCFB1HZ-104Y	0.1MF 50V CER. CAP.	
		RESISTORS		
△	R251	QRD14CJ-4R7SX	4.7 1/4W UNF. CARBON	C J
△	R252	QRD14CJ-4R7SX	4.7 1/4W UNF. CARBON	C J
	R253	QRD161J-221	220 1/6W CARBON RE	
	R254	QRD161J-221	220 1/6W CARBON RE	
	R255	QRD161J-331	330 1/6W CARBON RE	
△	R256	QRD14CJ-122SX	1.2K 1/4W UNF. CARBON	
	R258	QRD161J-122	1.2K 1/6W CARBON RE	
	R259	QRD161J-122	1.2K 1/6W CARBON RE	
	R260	QRD161J-331	330 1/6W CARBON RE	
	R261	QRD161J-331	330 1/6W CARBON RE	
△	R262	QRD12CJ-120SX	12 1/2W UNF. CARBON	C J
△	R263	QRD12CJ-120SX	12 1/2W UNF. CARBON	C J
	R264	QRD167J-152	1.5K 1/6W CARBON RE	
	R265	QRD161J-331	330 1/6W CARBON RE	
	R266	QRD167J-562	5.6K 1/6W CARBON RE	
	R267	QRD161J-221	220 1/6W CARBON RE	
	R268	QRD161J-221	220 1/6W CARBON RE	
	R270	QRD161J-122	1.2K 1/6W CARBON RE	
△	R272	QRD12CJ-150S	15 1/2W UNF. CARBON	C J
△	R273	QRD12CJ-150S	15 1/2W UNF. CARBON	C J
	R276	QRD167J-562	5.6K 1/6W CARBON RE	
	R277	QRD167J-152	1.5K 1/6W CARBON RE	
△	R278	QRD14CJ-100SX	10 1/4W UNF. CARBON	J
△		QRZ0077-100	10 1/4W FUSIBLE RE	Except J
	R279	QRD167J-562	5.6K 1/6W CARBON RE	
	R280	QRD167J-272	2.7K 1/6W CARBON RE	
	R401	QRD161J-221	220 1/6W CARBON RE	
	R402	QRD161J-221	220 1/6W CARBON RE	
	R403	QRD161J-913	91K 1/6W CARBON RE	
	R404	QRD161J-913	91K 1/6W CARBON RE	
	R405	QRD161J-101	100 1/6W CARBON RE	BS EF EN G VX
	R406	QRD161J-101	100 1/6W CARBON RE	BS EF EN G VX
	R407	QRD167J-822	8.2K 1/6W CARBON RE	
	R408	QRD167J-822	8.2K 1/6W CARBON RE	
	R409	QRD161J-103	10K 1/6W CARBON RE	
	R410	QRD161J-103	10K 1/6W CARBON RE	
	R413	QRD167J-272	2.7K 1/6W CARBON RE	
	R414	QRD167J-272	2.7K 1/6W CARBON RE	
	R415	QRD161J-222	2.2K 1/6W CARBON RE	
	R416	QRD161J-222	2.2K 1/6W CARBON RE	
	R417	QRD161J-123	12K 1/6W CARBON RE	
	R418	QRD161J-123	12K 1/6W CARBON RE	
	R421	QRD161J-473	47K 1/6W CARBON RE	
	R422	QRD161J-473	47K 1/6W CARBON RE	
	R425	QRD161J-103	10K 1/6W CARBON RE	
	R426	QRD161J-103	10K 1/6W CARBON RE	
	R427	QRD161J-103	10K 1/6W CARBON RE	
	R428	QRD161J-224	220K 1/6W CARBON RE	
	R429	QRD161J-104	100K 1/6W CARBON RE	
	R430	QRD161J-104	100K 1/6W CARBON RE	
	R431	QRD161J-221	220 1/6W CARBON RE	
	R432	QRD161J-221	220 1/6W CARBON RE	
	R433	QRD161J-273	27K 1/6W CARBON RE	
	R434	QRD161J-273	27K 1/6W CARBON RE	
	R435	QRD161J-103	10K 1/6W CARBON RE	
	R436	QRD161J-103	10K 1/6W CARBON RE	
	R437	QRD161J-102	1K 1/6W CARBON RE	
	R438	QRD161J-105	1M 1/6W CARBON RE	
	R439	QRD161J-102	1K 1/6W CARBON RE	
	R440	QRD161J-473	47K 1/6W CARBON RE	
	R441	QRD161J-102	1K 1/6W CARBON RE	
	R442	QRD161J-221	220 1/6W CARBON RE	
	R443	QRD161J-221	220 1/6W CARBON RE	
	R486	QRD161J-101	100 1/6W CARBON RE	
	R489	QRD161J-221	220 1/6W CARBON RE	
	R490	QRD161J-221	220 1/6W CARBON RE	
	R491	QRD161J-221	220 1/6W CARBON RE	
	R801	QRD161J-102	1K 1/6W CARBON RE	
	R802	QRD161J-103	10K 1/6W CARBON RE	
	R804	QRD161J-221	220 1/6W CARBON RE	
	R806	QRD161J-221	220 1/6W CARBON RE	

△	Item	Parts Number	Description	Area
	R807	QRD161J-221	220 1/6W CARBON RE	
	R808	QRD161J-221	220 1/6W CARBON RE	
	R809	QRD161J-221	220 1/6W CARBON RE	
	R810	QRD161J-221	220 1/6W CARBON RE	
	R811	QRD161J-221	220 1/6W CARBON RE	
	R816	QRD161J-103	10K 1/6W CARBON RE	
	R817	QRD161J-103	10K 1/6W CARBON RE	
	R818	QRD161J-103	10K 1/6W CARBON RE	
	R819	QRD161J-103	10K 1/6W CARBON RE	
	R820	QRD161J-181	180 1/6W CARBON RE	
	R821	QRD161J-181	180 1/6W CARBON RE	
	R824	QRD161J-271	270 1/6W CARBON RE	
	R825	QRD161J-271	270 1/6W CARBON RE	
	R826	QRD161J-181	180 1/6W CARBON RE	
	R827	QRD161J-181	180 1/6W CARBON RE	
	R828	QRD161J-331	330 1/6W CARBON RE	
	R832	QRD161J-104	100K 1/6W CARBON RE	
	R833	QRD161J-104	100K 1/6W CARBON RE	
	R834	QRD161J-104	100K 1/6W CARBON RE	
	R838	QRD161J-473	47K 1/6W CARBON RE	
	R901	QRD167J-153	15K 1/6W CARBON RE	
	R902	QRD167J-153	15K 1/6W CARBON RE	
	R903	QRD161J-913	91K 1/6W CARBON RE	
	R904	QRD161J-913	91K 1/6W CARBON RE	
	R908	QRD161J-102	1K 1/6W CARBON RE	
	R909	QRD161J-102	1K 1/6W CARBON RE	
	R915	QRD161J-103	10K 1/6W CARBON RE	
	R916	QRD161J-222	2.2K 1/6W CARBON RE	
	R917	QRD161J-222	2.2K 1/6W CARBON RE	
	R918	QRD161J-222	2.2K 1/6W CARBON RE	
		OTHERS		
		EMW10707-003	PRINTED BOARD	
	J401	QNN0018-002	PIN JACK	
	J891	QMS3R80-EE0S	HEADPHONE JACK	
	S801	ESP0001-023M	TACT SWITCH	
	S802	ESP0001-023M	TACT SWITCH	
	S803	ESP0001-023M	TACT SWITCH	
	S804	ESP0001-023M	TACT SWITCH	
	S805	ESP0001-023M	TACT SWITCH	
	S806	ESP0001-023M	TACT SWITCH	
	S807	ESP0001-023M	TACT SWITCH	
	S808	ESP0001-023M	TACT SWITCH	
	S809	ESP0001-023M	TACT SWITCH	
	S810	ESP0001-023M	TACT SWITCH	
	S811	ESP0001-023M	TACT SWITCH	
	S812	ESP0001-023M	TACT SWITCH	
	S813	ESP0001-023M	TACT SWITCH	
	S814	ESP0001-023M	TACT SWITCH	
	S815	ESP0001-023M	TACT SWITCH	
	S816	ESP0001-023M	TACT SWITCH	
	*S817	ESP0001-023M	TACT SWITCH	
	*S818	ESP0001-023M	TACT SWITCH	
	*S819	ESP0001-023M	TACT SWITCH	
	*S820	ESP0001-023M	TACT SWITCH	
	X401	ECX0004-194KM	CERAMIC RESONATOR	
	X801	FSCX4001-002	CRYSTAL	
	BK801	LE30338-001A	HOLDER BRACKET	
	*CN102	EWS265-A420	SOCKET WIRE ASSY	
	CN251	EMV5163-009R	CONNECT TERMINAL	
	CN401	EMV5163-016R	SOCKET WIRE ASSY	
	CN402	EMV5163-020R	CONNECT TERMINAL	
	CN801	VMC0163-R27	CONNECT TERMINAL	
	D1801	QLF0020-001	FLUORESCENT DISPLAY TUB	
	FS801	LE30001-002A	FELT SPACER	
	FS814	E3400-431	FELT SPACER	
	FW202	EWR33D-16LS	FLAT WIRE	
	FW891	EWR36D-37LS	FLAT WIRE	
	SP401	VYH7653-001	LEAF SPRING	
	SP801	VYH7653-001	LEAF SPRING	

RX-TD5/RX-TD55R

■ Electrical Parts List (ENA-178AM) - Only for C and J -

△	Item	Parts Number	Description	Area
		I. C. S		
	IC102	LA1837	I. C (MONO-ANALOG)	
	IC121	LC72131	I. C (M)	
		DIODES		
	D121	1SS133	SI. DIODE	
	D123	1SS133	SI. DIODE	
	D129	1SS133	SI. DIODE	
	D130	MTZ10JC	ZENER DIODE	
		TRANSISTORS		
	Q101	2SC461	SI. TRANSISTOR	
	Q102	2SC535	SI. TRANSISTOR	
	Q103	2SC461	SI. TRANSISTOR	
	Q121	DTA124ES	DIGITAL TRANSISTOR	
	Q123	2SC2060 (Q. R)	SI. TRANSISTOR	
		CAPACITORS		
	C101	QCVB1CM-103Y	0.01MF 16V CER. CAP.	
	C102	QETN1EM-107Z	100MF 25V E. CAP.	
	C103	QCHB1EZ-223	0.022MF 25V CER. CAP.	
	C104	QCHB1EZ-223	0.022MF 25V CER. CAP.	
	C105	QCHB1EZ-223	0.022MF 25V CER. CAP.	
	C107	QETN1EM-226Z	22MF 25V E. CAP.	
	C109	QETN1EM-226Z	22MF 25V E. CAP.	
	C111	QCHB1EZ-223	0.022MF 25V CER. CAP.	
	C112	QCT30CH-120Y	12PF 50V CER. CAP.	
	C117	QCSB1HK-5R6Y	5.6PF 50V CER. CAP.	
	C118	QCSB1HJ-150Y	15PF 50V CER. CAP.	
	C121	QCT30CH-180Y	18PF 50V CER. CAP.	
	C122	QCT30CH-180Y	18PF 50V CER. CAP.	
	C123	QCC21EM-473	0.047MF 25V CER. CAP.	
	C126	QCBB1HK-101Y	100PF 50V CER. CAP.	
	C128	QENB1HM-474	0.47MF 50V NP E. CAP.	
	C129	QCCB1HK-102	1000PF 50V CER. CAP.	
	C130	QETN1EM-107Z	100MF 25V E. CAP.	
	C133	QETN1EM-226Z	22MF 25V E. CAP.	
	C134	QCBB1HK-331Y	330PF 50V CER. CAP.	
	C135	QCHB1EZ-223	0.022MF 25V CER. CAP.	
	C136	QETN1HM-105Z	1MF 50V AL E. CAP.	
	C137	QCBB1HK-681Y	680PF 50V CER. CAP.	
	C139	QFLB1HJ-333	0.033MF 50V MYLAR CAP.	
	C140	QFLB1HJ-333	0.033MF 50V MYLAR CAP.	
	C141	QCC21EM-473	0.047MF 25V CER. CAP.	
	C143	QCHB1EZ-223	0.022MF 25V CER. CAP.	
	C144	QCC21EM-473	0.047MF 25V CER. CAP.	
	C146	QETN1HM-105Z	1MF 50V AL E. CAP.	
	C147	QETN1HM-105Z	1MF 50V AL E. CAP.	
	C148	QETN1HM-474Z	0.47MF 50V AL E. CAP.	
	C149	QETN1HM-105Z	1MF 50V AL E. CAP.	
	C150	QETN1EM-226Z	22MF 25V E. CAP.	
	C156	QCHB1EZ-223	0.022MF 25V CER. CAP.	
	C157	QCC21EM-473	0.047MF 25V CER. CAP.	
	C158	QETN1EM-226Z	22MF 25V E. CAP.	
	C161	QETN1HM-105Z	1MF 50V AL E. CAP.	
	C162	QETN1HM-105Z	1MF 50V AL E. CAP.	
	C163	QCHB1EZ-223	0.022MF 25V CER. CAP.	
	C164	QCC21EM-473	0.047MF 25V CER. CAP.	
	C168	QFV81HJ-274	0.27MF 50V THIN FILM CAP.	
	C180	QETN1EM-107Z	100MF 25V E. CAP.	
	C181	QFLB1HJ-562	5600PF 50V MYLAR CAP.	
	C182	QFLB1HJ-562	5600PF 50V MYLAR CAP.	
	C183	QCHB1EZ-223	0.022MF 25V CER. CAP.	
	C184	QETN1EM-107Z	100MF 25V E. CAP.	
	C185	QETN1HM-105Z	1MF 50V AL E. CAP.	
	C186	QETN1HM-105Z	1MF 50V AL E. CAP.	
		RESISTORS		
	R102	QRD167J-332	3.3K 1/6W CARBON RES.	
	R103	QRD161J-221	220 1/6W CARBON RES.	
	R104	QRD167J-272	2.7K 1/6W CARBON RES.	
	R105	QRD161J-391	390 1/6W CARBON RES.	
	R106	QRD161J-102	1K 1/6W CARBON RES.	
	R107	QRD161J-561	560 1/6W CARBON RES.	

△	Item	Parts Number	Description	Area
	R108	QRD167J-332	3.3K 1/6W CARBON RES.	
	R109	QRD161J-221	220 1/6W CARBON RES.	
	R115	QRD161J-104	100K 1/6W CARBON RES.	
	R119	QRD161J-103	10K 1/6W CARBON RES.	
	R121	QRD161J-473	47K 1/6W CARBON RES.	
	R122	QRD161J-472	4.7K 1/6W CARBON RES.	
	R124	QRD161J-222	2.2K 1/6W CARBON RES.	
	R126	QRD167J-562	5.6K 1/6W CARBON RES.	
	R127	QRD167J-822	8.2K 1/6W CARBON RES.	
	R128	QRD161J-472	4.7K 1/6W CARBON RES.	
	R129	QRD161J-222	2.2K 1/6W CARBON RES.	
△	R130	QRD14CJ-680SX	68 1/4W UNF. CARBON R	
	R132	QRD161J-102	1K 1/6W CARBON RES.	
	R133	QRD167J-822	8.2K 1/6W CARBON RES.	
	R134	QRD161J-102	1K 1/6W CARBON RES.	
	R140	QRD161J-183	18K 1/6W CARBON RES.	
	R141	QRD161J-472	4.7K 1/6W CARBON RES.	
	R142	QRD161J-470	47 1/6W CARBON RES.	
	R143	QRD167J-562	5.6K 1/6W CARBON RES.	
	R144	QRD167J-332	3.3K 1/6W CARBON RES.	
	R145	QRD161J-103	10K 1/6W CARBON RES.	
	R146	QRD167J-332	3.3K 1/6W CARBON RES.	
	R147	QRD167J-153	15K 1/6W CARBON RES.	
	R148	QRD161J-561	560 1/6W CARBON RES.	
	R150	QRD161J-101	100 1/6W CARBON RES.	
	R157	QRD167J-682	6.8K 1/6W CARBON RES.	
	R158	QRD167J-682	6.8K 1/6W CARBON RES.	
	R161	QRD161J-102	1K 1/6W CARBON RES.	
	R162	QRD161J-102	1K 1/6W CARBON RES.	
	R163	QRD161J-472	4.7K 1/6W CARBON RES.	
	R164	QRD161J-472	4.7K 1/6W CARBON RES.	
	R181	QRD161J-102	1K 1/6W CARBON RES.	
	R182	QRD161J-103	10K 1/6W CARBON RES.	
	R183	QRD161J-103	10K 1/6W CARBON RES.	
	R184	QRD161J-103	10K 1/6W CARBON RES.	
		OTHERS		
		EMW10684-003A	PRINTED BOARD	
	L111	EQL4007-150T	INDUCTOR	
	T111	EQR7121-007	RF COIL	
	T141	QQR0613-001	I. F. TRANSFORMER	
	T142	QAX0303-001	CERAMIC FILTER	
	X121	ECX0007-200KWJ1	CRYSTAL	
	AT101	FMMB10YV-401K	ANTENNA TERMINAL	
	CF101	QAX0284-001Z	CERAMIC FILTER	
	CF102	QAX0284-001Z	CERAMIC FILTER	
	CN111	EMV5163-012R	CONNECT TERMINAL	
	FL141	EQF0101-013	LOWPASS FILTER	
	FL142	EQF0101-013	LOWPASS FILTER	
	RF101	EAF2207-001	FRONT END	

■ Electrical Parts List (ENA-178BM/178CM) - Only for BS, EF, EN and G -

* Only for RX-TD55R

△	Item	Parts Number	Description	Area
		I. C. S		
	IC102	LA1837	I. C (MONO-ANALOG)	
	IC121	LG72131	I. C (M)	
	*IC191	LG7073	I. C (DIGI-MOS)	
	*IC192	SAA6579	I. C (M)	
		DIODES		
	D121	1S5133	SI. DIODE	
	D123	1S5133	SI. DIODE	
	D129	1S5133	SI. DIODE	
	D130	MTZ10JG	ZENER DIODE	
	*D131	1S5133	SI. DIODE	
		TRANSISTORS		
	Q101	2SC461	SI. TRANSISTOR	
	Q102	2SC535	SI. TRANSISTOR	
	Q103	2SC461	SI. TRANSISTOR	
	Q111	2SD2144S (VW)	SI. TRANSISTOR	
	Q112	2SD2144S (VW)	SI. TRANSISTOR	
	Q113	2SD2144S (VW)	SI. TRANSISTOR	
	Q114	2SD2144S (VW)	SI. TRANSISTOR	
	Q121	DTA124ES	DIGITAL TRANSISTOR	
	Q123	2SC2060 (Q, R)	SI. TRANSISTOR	
		CAPACITORS		
	C101	QCVB1CM-103Y	0.01MF 16V CER. CAP.	
	C102	QETN1EM-107Z	100MF 25V E. CAP.	
	C103	QCHB1EZ-223	0.022MF 25V CER. CAP.	
	C104	QCHB1EZ-223	0.022MF 25V CER. CAP.	
	C105	QCHB1EZ-223	0.022MF 25V CER. CAP.	
	C107	QETN1EM-226Z	22MF 25V E. CAP.	
	C109	QETN1EM-226Z	22MF 25V E. CAP.	
	C111	QCHB1EZ-223	0.022MF 25V CER. CAP.	
	C112	QCT30CH-120Y	12PF 50V CER. CAP.	
	C113	QCHB1EZ-223	0.022MF 25V CER. CAP.	
	C117	QCSB1HK-5R6Y	5.6PF 50V CER. CAP.	
	C118	QCSB1HJ-150Y	15PF 50V CER. CAP.	
	C121	QCT30CH-180Y	18PF 50V CER. CAP.	
	C122	QCT30CH-180Y	18PF 50V CER. CAP.	
	C123	QCC21EM-473	0.047MF 25V CER. CAP.	
	C126	QCBB1HK-101Y	100PF 50V CER. CAP.	
	C128	QENB1HM-474	0.47MF 50V NP E. CAP.	
	C129	QCGB1HK-102	1000PF 50V CER. CAP.	
	C130	QETN1EM-107Z	100MF 25V E. CAP.	
	C133	QETN1EM-226Z	22MF 25V E. CAP.	
	C134	QCBB1HK-331Y	330PF 50V CER. CAP.	
	C135	QCHB1EZ-223	0.022MF 25V CER. CAP.	
	C136	QETN1HM-105Z	1MF 50V AL E. CAP.	
	C137	QCBB1HK-391Y	390PF 50V CER. CAP.	
	C139	QFLB1HJ-473	0.047MF 50V MYLAR CAP.	
	C140	QFLB1HJ-473	0.047MF 50V MYLAR CAP.	
	C141	QCC21EM-473	0.047MF 25V CER. CAP.	
	C143	QCHB1EZ-223	0.022MF 25V CER. CAP.	
	C144	QCC21EM-473	0.047MF 25V CER. CAP.	
	C146	QETN1HM-105Z	1MF 50V AL E. CAP.	
	C147	QETN1HM-105Z	1MF 50V AL E. CAP.	
	C148	QETN1HM-474Z	0.47MF 50V AL E. CAP.	
	C149	QETN1HM-105Z	1MF 50V AL E. CAP.	
	C150	QETN1EM-226Z	22MF 25V E. CAP.	
	C156	QCHB1EZ-223	0.022MF 25V CER. CAP.	
	C157	QCC21EM-473	0.047MF 25V CER. CAP.	
	C158	QETN1EM-226Z	22MF 25V E. CAP.	
	C161	QETN1HM-105Z	1MF 50V AL E. CAP.	
	C162	QETN1HM-105Z	1MF 50V AL E. CAP.	
	C163	QCHB1EZ-223	0.022MF 25V CER. CAP.	
	C164	QCC21EM-473	0.047MF 25V CER. CAP.	
	C168	QFV81HJ-274	0.27MF 50V THIN FILM CAP.	
	C180	QETN1EM-107Z	100MF 25V E. CAP.	
	C181	QFLB1HJ-562	5600PF 50V MYLAR CAP.	
	C182	QFLB1HJ-562	5600PF 50V MYLAR CAP.	
	C183	QCHB1EZ-223	0.022MF 25V CER. CAP.	
	C184	QETN1EM-107Z	100MF 25V E. CAP.	
	C185	QETN1HM-105Z	1MF 50V AL E. CAP.	
	C186	QETN1HM-105Z	1MF 50V AL E. CAP.	
	*C191	QCBB1HK-820Y	82PF 50V CER. CAP.	
	*C192	QCSB1HJ-470	47PF 50V CER. CAP.	
	*C193	QCBB1HK-561Y	560PF 50V CER. CAP.	

△	Item	Parts Number	Description	Area
	*C194	QCHB1EZ-223	0.022MF 25V CER. CAP.	
	*C195	QCBB1HK-331Y	330PF 50V CER. CAP.	
	*C196	QETN1EM-226Z	22MF 25V E. CAP.	
	*C197	QCZ0205-155	1.5MF 25V C. CAP.	
	*C199	QETN1EM-226Z	22MF 25V E. CAP.	
		RESISTORS		
	R102	QRD167J-332	3.3K 1/6W CARBON RES.	
	R103	QRD161J-221	220 1/6W CARBON RES.	
	R104	QRD167J-272	2.7K 1/6W CARBON RES.	
	R105	QRD161J-391	390 1/6W CARBON RES.	
	R106	QRD161J-102	1K 1/6W CARBON RES.	
	R107	QRD161J-561	560 1/6W CARBON RES.	
	R108	QRD167J-332	3.3K 1/6W CARBON RES.	
	R109	QRD161J-221	220 1/6W CARBON RES.	
	R110	QRD161J-472	4.7K 1/6W CARBON RES.	
	R111	QRD161J-472	4.7K 1/6W CARBON RES.	
	R112	QRD161J-472	4.7K 1/6W CARBON RES.	
	R113	QRD161J-103	10K 1/6W CARBON RES.	
	R114	QRD161J-122	1.2K 1/6W CARBON RES.	
	R115	QRD161J-104	100K 1/6W CARBON RES.	
	R116	QRD161J-472	4.7K 1/6W CARBON RES.	
	R119	QRD161J-103	10K 1/6W CARBON RES.	
	R121	QRD161J-473	47K 1/6W CARBON RES.	
	R122	QRD161J-472	4.7K 1/6W CARBON RES.	
	R124	QRD161J-222	2.2K 1/6W CARBON RES.	
	R126	QRD167J-562	5.6K 1/6W CARBON RES.	
	R127	QRD167J-822	8.2K 1/6W CARBON RES.	
	R128	QRD161J-472	4.7K 1/6W CARBON RES.	
	R129	QRD161J-222	2.2K 1/6W CARBON RES.	
△	R130	QRZ0077-680	68 1/4W FUSIBLE RES.	
	R131	QRD161J-103	10K 1/6W CARBON RES.	
	R132	QRD161J-102	1K 1/6W CARBON RES.	
	R133	QRD167J-822	8.2K 1/6W CARBON RES.	
	R134	QRD161J-102	1K 1/6W CARBON RES.	
	R140	QRD161J-563	56K 1/6W CARBON RES.	
	R141	QRD161J-472	4.7K 1/6W CARBON RES.	
	R142	QRD161J-470	47 1/6W CARBON RES.	
	R143	QRD167J-562	5.6K 1/6W CARBON RES.	
	R144	QRD167J-332	3.3K 1/6W CARBON RES.	
	R145	QRD161J-103	10K 1/6W CARBON RES.	
	R146	QRD167J-562	5.6K 1/6W CARBON RES.	
	R147	QRD161J-273	27K 1/6W CARBON RES.	
	R148	QRD161J-561	560 1/6W CARBON RES.	
	R150	QRD161J-101	100 1/6W CARBON RES.	
	R157	QRD161J-182	1.8K 1/6W CARBON RES.	
	R158	QRD161J-182	1.8K 1/6W CARBON RES.	
	R161	QRD161J-102	1K 1/6W CARBON RES.	
	R162	QRD161J-102	1K 1/6W CARBON RES.	
	R163	QRD161J-472	4.7K 1/6W CARBON RES.	
	R164	QRD161J-472	4.7K 1/6W CARBON RES.	
	R181	QRD161J-102	1K 1/6W CARBON RES.	
	R182	QRD161J-103	10K 1/6W CARBON RES.	
	R183	QRD161J-103	10K 1/6W CARBON RES.	
	R184	QRD161J-103	10K 1/6W CARBON RES.	
	R191	QRD161J-222	2.2K 1/6W CARBON RES.	
		OTHERS		
		EMW10684-003A	PRINTED BOARD	
	L111	EQL4007-150T	INDUCTOR	
	T111	EQR7121-006	RF COIL	
	T141	QQR0613-001	I. F. TRANSFORMER	
	T142	QAX0303-001	CERAMIC FILTER	
	X121	ECX0007-200KWJ1	CRYSTAL	
	X191	VCX5057-001	CRYSTAL	
	X192	EFO-EC4004T4	CERAMIC RESONATOR	
	AT101	EMB41YV-302K	ANTENNA TERMINAL	
	BK001	E308963-223SM	SHIELD BRACKET	
	CF101	QAX0285-001Z	CERAMIC FILTER	
	CF102	QAX0285-001Z	CERAMIC FILTER	
	CN111	EMV5163-012R	CONNECT TERMINAL	
	CN112	EMV5109-005A	MALE CONNECTOR	
	FL141	EQF0101-013	LOWPASS FILTER	
	FL142	EQF0101-013	LOWPASS FILTER	
	RF101	QAU0005-001	FRONT END	

RX-TD5/RX-TD55R

■ Electrical Parts List (ENA-178DM) - Only for UB, U, UP, US and UT -

△	Item	Parts Number	Description	Area
		I. C. S		
	IC102	LA1837	I. C (MONO-ANALOG)	
	IC121	LC72131	I. C (M)	
		DIODES		
	D121	1SS133	SI. DIODE	
	D123	1SS133	SI. DIODE	
	D129	1SS133	SI. DIODE	
	D130	MTZ10JC	ZENER DIODE	
		TRANSISTORS		
	Q101	2SC461	SI. TRANSISTOR	
	Q102	2SC535	SI. TRANSISTOR	
	Q103	2SC461	SI. TRANSISTOR	
	Q121	DTA124ES	DIGITAL TRANSISTOR	
	Q123	2SC2060 (Q, R)	SI. TRANSISTOR	
		CAPACITORS		
	C101	QCVB1CM-103Y	0.01MF 16V CER. CAP.	
	C102	QETN1EM-107Z	100MF 25V E. CAP.	
	C103	QCHB1EZ-223	0.022MF 25V CER. CAP.	
	C104	QCHB1EZ-223	0.022MF 25V CER. CAP.	
	C105	QCHB1EZ-223	0.022MF 25V CER. CAP.	
	C107	QETN1EM-226Z	22MF 25V E. CAP.	
	C109	QETN1EM-226Z	22MF 25V E. CAP.	
	C111	QCHB1EZ-223	0.022MF 25V CER. CAP.	
	C112	QCT30CH-120Y	12PF 50V CER. CAP.	
	C117	QCSB1HK-5R6Y	5.6PF 50V CER. CAP.	
	C118	QCSB1HJ-150Y	15PF 50V CER. CAP.	
	C121	QCT30CH-180Y	18PF 50V CER. CAP.	
	C122	QCT30CH-180Y	18PF 50V CER. CAP.	
	C123	QCC21EM-473	0.047MF 25V CER. CAP.	
	C126	QCB1HK-101Y	100PF 50V CER. CAP.	
	C128	QENB1HM-474	0.47MF 50V NP E. CAP.	
	C129	QCG1HK-102	1000PF 50V CER. CAP.	
	C130	QETN1EM-107Z	100MF 25V E. CAP.	
	C133	QETN1EM-226Z	22MF 25V E. CAP.	
	C134	QCB1HK-331Y	330PF 50V CER. CAP.	
	C135	QCHB1EZ-223	0.022MF 25V CER. CAP.	
	C136	QETN1HM-105Z	1MF 50V AL E. CAP.	
	C137	QCB1HK-561Y	560PF 50V CER. CAP.	
	C139	QFLB1HJ-223	0.022MF 50V MYLAR CAP.	
	C140	QFLB1HJ-223	0.022MF 50V MYLAR CAP.	
	C141	QCC21EM-473	0.047MF 25V CER. CAP.	
	C143	QCHB1EZ-223	0.022MF 25V CER. CAP.	
	C144	QCC21EM-473	0.047MF 25V CER. CAP.	
	C146	QETN1HM-105Z	1MF 50V AL E. CAP.	
	C147	QETN1HM-105Z	1MF 50V AL E. CAP.	
	C148	QETN1HM-474Z	0.47MF 50V AL E. CAP.	
	C149	QETN1HM-105Z	1MF 50V AL E. CAP.	
	C150	QETN1EM-226Z	22MF 25V E. CAP.	
	C156	QCHB1EZ-223	0.022MF 25V CER. CAP.	
	C157	QCC21EM-473	0.047MF 25V CER. CAP.	
	C158	QETN1EM-226Z	22MF 25V E. CAP.	
	C161	QETN1HM-105Z	1MF 50V AL E. CAP.	
	C162	QETN1HM-105Z	1MF 50V AL E. CAP.	
	C163	QCHB1EZ-223	0.022MF 25V CER. CAP.	
	C164	QCC21EM-473	0.047MF 25V CER. CAP.	
	C168	QFV81HJ-274	0.27MF 50V THIN FILM CAP.	
	C180	QETN1EM-107Z	100MF 25V E. CAP.	
	C181	QFLB1HJ-562	5600PF 50V MYLAR CAP.	
	C182	QFLB1HJ-562	5600PF 50V MYLAR CAP.	
	C183	QCHB1EZ-223	0.022MF 25V CER. CAP.	
	C184	QETN1EM-107Z	100MF 25V E. CAP.	
	C185	QETN1HM-105Z	1MF 50V AL E. CAP.	
	C186	QETN1HM-105Z	1MF 50V AL E. CAP.	
		RESISTORS		
	R102	QRD167J-332	3.3K 1/6W CARBON RES.	
	R103	QRD161J-221	220 1/6W CARBON RES.	
	R104	QRD167J-272	2.7K 1/6W CARBON RES.	
	R105	QRD161J-391	390 1/6W CARBON RES.	
	R106	QRD161J-102	1K 1/6W CARBON RES.	
	R107	QRD161J-561	560 1/6W CARBON RES.	

△	Item	Parts Number	Description	Area
	R108	QRD167J-332	3.3K 1/6W CARBON RES.	
	R109	QRD161J-221	220 1/6W CARBON RES.	
	R115	QRD161J-104	100K 1/6W CARBON RES.	
	R119	QRD161J-103	10K 1/6W CARBON RES.	
	R121	QRD161J-473	47K 1/6W CARBON RES.	
	R122	QRD161J-472	4.7K 1/6W CARBON RES.	
	R124	QRD161J-222	2.2K 1/6W CARBON RES.	
	R126	QRD167J-562	5.6K 1/6W CARBON RES.	
	R127	QRD167J-822	8.2K 1/6W CARBON RES.	
	R128	QRD161J-472	4.7K 1/6W CARBON RES.	
	R129	QRD161J-222	2.2K 1/6W CARBON RES.	
△	R130	QRZ0077-680	68 1/4W FUSIBLE RES.	
	R132	QRD161J-102	1K 1/6W CARBON RES.	
	R133	QRD167J-822	8.2K 1/6W CARBON RES.	
	R134	QRD161J-102	1K 1/6W CARBON RES.	
	R140	QRD161J-183	18K 1/6W CARBON RES.	
	R141	QRD161J-472	4.7K 1/6W CARBON RES.	
	R142	QRD161J-470	47 1/6W CARBON RES.	
	R143	QRD167J-562	5.6K 1/6W CARBON RES.	
	R144	QRD167J-332	3.3K 1/6W CARBON RES.	
	R145	QRD161J-103	10K 1/6W CARBON RES.	
	R146	QRD167J-332	3.3K 1/6W CARBON RES.	
	R147	QRD161J-273	27K 1/6W CARBON RES.	
	R148	QRD161J-561	560 1/6W CARBON RES.	
	R150	QRD161J-101	100 1/6W CARBON RES.	
	R157	QRD167J-682	6.8K 1/6W CARBON RES.	
	R158	QRD167J-682	6.8K 1/6W CARBON RES.	
	R161	QRD161J-102	1K 1/6W CARBON RES.	
	R162	QRD161J-102	1K 1/6W CARBON RES.	
	R163	QRD161J-472	4.7K 1/6W CARBON RES.	
	R164	QRD161J-472	4.7K 1/6W CARBON RES.	
	R181	QRD161J-102	1K 1/6W CARBON RES.	
	R182	QRD161J-103	10K 1/6W CARBON RES.	
	R183	QRD161J-103	10K 1/6W CARBON RES.	
	R184	QRD161J-103	10K 1/6W CARBON RES.	
		OTHERS		
		EMW10684-003A	PRINTED BOARD	
	L111	EQL4007-150T	INDUCTOR	
	T111	EQR7121-007	RF COIL	
	T141	QQR0613-001	I. F. TRANSFORMER	
	T142	QAX0303-001	CERAMIC FILTER	
	X121	EGX0007-200KWJ1	CRYSTAL	
	AT101	FMMB10YV-401K	ANTENNA TERMINAL	
	CF101	QAX0285-001Z	CERAMIC FILTER	
	CF102	QAX0285-001Z	CERAMIC FILTER	
	CN111	EMV5163-012R	CONNECT TERMINAL	
	FL141	EQF0101-013	LOWPASS FILTER	
	FL142	EQF0101-013	LOWPASS FILTER	
	RF101	EAF2207-001	FRONT END	

■ Electrical Parts List (ENA-178EM) - Only for VX -

△	Item	Parts Number	Description	Area
		I. C. S		
	IC102	LA1837	I. C (MONO-ANALOG)	
	IC104	IR3R42	I. C (MONO-ANALOG)	
	IC121	LG72131	I. C (M)	
		DIODES		
	D121	1SS133	SI. DIODE	
	D122	1SS133	SI. DIODE	
	D123	1SS133	SI. DIODE	
	D124	1SS133	SI. DIODE	
	D129	1SS133	SI. DIODE	
	D130	MTZ10JC	ZENER DIODE	
	D132	1SS133	SI. DIODE	
	D133	MTZ6.8JC	ZENER DIODE	
		TRANSISTORS		
	Q101	2SC461	SI. TRANSISTOR	
	Q102	2SC535	SI. TRANSISTOR	
	Q103	2SC461	SI. TRANSISTOR	
	Q111	2SD2144S (VW)	SI. TRANSISTOR	
	Q112	2SD2144S (VW)	SI. TRANSISTOR	
	Q113	2SD2144S (VW)	SI. TRANSISTOR	
	Q114	2SD2144S (VW)	SI. TRANSISTOR	
	Q121	DTA124ES	DIGITAL TRANSISTOR	
	Q123	2SC2060 (Q, R)	SI. TRANSISTOR	
	Q131	DTA124ES	DIGITAL TRANSISTOR	
	Q132	2SK301 (P, Q)	F. E. T.	
	Q133	2SC2060 (Q, R)	SI. TRANSISTOR	
	Q134	DTC114YS	DIGITAL TRANSISTOR	
		CAPACITORS		
	C101	QCVB1CM-103Y	0.01MF 16V CER. CAP.	
	C102	QETN1EM-107Z	100MF 25V E. CAP.	
	C103	QCHB1EZ-223	0.022MF 25V CER. CAP.	
	C104	QCHB1EZ-223	0.022MF 25V CER. CAP.	
	C105	QCHB1EZ-223	0.022MF 25V CER. CAP.	
	C107	QETN1EM-226Z	22MF 25V E. CAP.	
	C109	QETN1EM-226Z	22MF 25V E. CAP.	
	C111	QCHB1EZ-223	0.022MF 25V CER. CAP.	
	C112	QCT30CH-120Y	12PF 50V CER. CAP.	
	C113	QCHB1EZ-223	0.022MF 25V CER. CAP.	
	C117	QCSB1HK-5R6Y	5.6PF 50V CER. CAP.	
	C118	QCSB1HJ-150Y	15PF 50V CER. CAP.	
	C121	QCT30CH-180Y	18PF 50V CER. CAP.	
	C122	QCT30CH-180Y	18PF 50V CER. CAP.	
	C123	QCC21EM-473	0.047MF 25V CER. CAP.	
	C126	QCBB1HK-101Y	100PF 50V CER. CAP.	
	C128	QENB1HM-474	0.47MF 50V NP E. CAP.	
	C129	QCGB1HK-102	1000PF 50V CER. CAP.	
	C130	QETN1EM-107Z	100MF 25V E. CAP.	
	C131	QETN1HM-105Z	1MF 50V AL E. CAP.	
	C132	QETN1HM-105Z	1MF 50V AL E. CAP.	
	C133	QETN1EM-226Z	22MF 25V E. CAP.	
	C134	QCBB1HK-331Y	330PF 50V CER. CAP.	
	C135	QCHB1EZ-223	0.022MF 25V CER. CAP.	
	C136	QETN1HM-105Z	1MF 50V AL E. CAP.	
	C138	QCBB1HK-221Y	220PF 50V CER. CAP.	
	C139	QFLB1HJ-333	0.033MF 50V MYLAR CAP.	
	C140	QFLB1HJ-333	0.033MF 50V MYLAR CAP.	
	C141	QCC21EM-473	0.047MF 25V CER. CAP.	
	C143	QCHB1EZ-223	0.022MF 25V CER. CAP.	
	C144	QCC21EM-473	0.047MF 25V CER. CAP.	
	C146	QETN1HM-105Z	1MF 50V AL E. CAP.	
	C147	QETN1HM-105Z	1MF 50V AL E. CAP.	
	C148	QETN1HM-474Z	0.47MF 50V AL E. CAP.	
	C149	QETN1HM-105Z	1MF 50V AL E. CAP.	
	C150	QETN1EM-226Z	22MF 25V E. CAP.	
	C154	QETN1HM-105Z	1MF 50V AL E. CAP.	
	C155	QENC1HM-105Z	1MF 50V NP E. CAP.	
	C156	QCHB1EZ-223	0.022MF 25V CER. CAP.	
	C157	QCC21EM-473	0.047MF 25V CER. CAP.	
	C158	QETN1EM-226Z	22MF 25V E. CAP.	
	C159	QFLB1HJ-183	0.018MF 50V MYLAR CAP.	
	C160	QFLB1HJ-183	0.018MF 50V MYLAR CAP.	
	C161	QETN1HM-105Z	1MF 50V AL E. CAP.	
	C162	QETN1HM-105Z	1MF 50V AL E. CAP.	
	C163	QCHB1EZ-223	0.022MF 25V CER. CAP.	
	C164	QCC21EM-473	0.047MF 25V CER. CAP.	
	C165	QCHB1EZ-223	0.022MF 25V CER. CAP.	
	C166	QETN1EM-107Z	100MF 25V E. CAP.	
	C167	QCHB1EZ-223	0.022MF 25V CER. CAP.	
	C168	QFV81HJ-274	0.27MF 50V THIN FILM CAP.	
	C170	QETN1HM-105Z	1MF 50V AL E. CAP.	
	C171	QFP81HJ-103	0.01MF 50V POLYPROPY. FILM	
	C172	QFP81HJ-103	0.01MF 50V POLYPROPY. FILM	
	C173	QCBB1HK-102Y	1000PF 50V CER. CAP.	
	C174	QCBB1HK-102Y	1000PF 50V CER. CAP.	
	C177	QCBB1HK-331Y	330PF 50V CER. CAP.	
	C178	QENC1HM-105Z	1MF 50V NP E. CAP.	
	C179	QCC21EM-473	0.047MF 25V CER. CAP.	
	C180	QETN1EM-107Z	100MF 25V E. CAP.	
	C181	QFLB1HJ-562	5600PF 50V MYLAR CAP.	
	C182	QFLB1HJ-562	5600PF 50V MYLAR CAP.	
	C183	QCHB1EZ-223	0.022MF 25V CER. CAP.	
	C184	QETN1EM-107Z	100MF 25V E. CAP.	
	C185	QETN1HM-105Z	1MF 50V AL E. CAP.	
	C186	QETN1HM-105Z	1MF 50V AL E. CAP.	
	C187	QCGB1HK-102	1000PF 50V CER. CAP.	
	C188	QENB1HM-474	0.47MF 50V NP E. CAP.	
	C189	QENB1HM-474	0.47MF 50V NP E. CAP.	
	C190	QFP81HJ-471	470PF 50V POLYPROPY. FILM	
	TC101	ENZ1003-015	0.1MF TRIMMER CAPA	
		RESISTORS		
	R102	QRD167J-332	3.3K 1/6W CARBON RES.	
	R103	QRD161J-221	220 1/6W CARBON RES.	
	R104	QRD167J-272	2.7K 1/6W CARBON RES.	
	R105	QRD161J-391	390 1/6W CARBON RES.	
	R106	QRD161J-102	1K 1/6W CARBON RES.	
	R107	QRD161J-561	560 1/6W CARBON RES.	
	R108	QRD167J-332	3.3K 1/6W CARBON RES.	
	R109	QRD161J-221	220 1/6W CARBON RES.	
	R110	QRD161J-472	4.7K 1/6W CARBON RES.	
	R111	QRD161J-472	4.7K 1/6W CARBON RES.	
	R112	QRD161J-472	4.7K 1/6W CARBON RES.	
	R113	QRD161J-103	10K 1/6W CARBON RES.	
	R114	QRD161J-122	1.2K 1/6W CARBON RES.	
	R115	QRD161J-104	100K 1/6W CARBON RES.	
	R116	QRD161J-472	4.7K 1/6W CARBON RES.	
	R119	QRD161J-103	10K 1/6W CARBON RES.	
	R122	QRD161J-472	4.7K 1/6W CARBON RES.	
	R124	QRD161J-222	2.2K 1/6W CARBON RES.	
	R126	QRD167J-562	5.6K 1/6W CARBON RES.	
	R127	QRD167J-822	8.2K 1/6W CARBON RES.	
	R128	QRD161J-472	4.7K 1/6W CARBON RES.	
	R129	QRD161J-222	2.2K 1/6W CARBON RES.	
△	R130	QRZ0077-680	68 1/4W FUSIBLE RES.	
	R131	QRD161J-103	10K 1/6W CARBON RES.	
	R132	QRD161J-102	1K 1/6W CARBON RES.	
	R133	QRD167J-822	8.2K 1/6W CARBON RES.	
	R134	QRD161J-102	1K 1/6W CARBON RES.	
	R137	QRD161J-103	10K 1/6W CARBON RES.	
	R138	QRD161J-104	100K 1/6W CARBON RES.	
	R139	QRD161J-104	100K 1/6W CARBON RES.	
	R140	QRD161J-183	18K 1/6W CARBON RES.	
	R141	QRD161J-472	4.7K 1/6W CARBON RES.	
	R142	QRD161J-470	47 1/6W CARBON RES.	
	R143	QRD167J-562	5.6K 1/6W CARBON RES.	
	R144	QRD167J-332	3.3K 1/6W CARBON RES.	
	R145	QRD161J-103	10K 1/6W CARBON RES.	
	R146	QRD167J-562	5.6K 1/6W CARBON RES.	
	R147	QRD167J-153	15K 1/6W CARBON RES.	
	R148	QRD161J-561	560 1/6W CARBON RES.	
	R150	QRD161J-101	100 1/6W CARBON RES.	

RX-TD5/RX-TD55R

■ Electrical Parts List (ENA-178EM) - Only for VX -

△	Item	Parts Number	Description	Area
	R151	QRD167J-153	15K 1/6W CARBON RES.	
	R152	QRD167J-153	15K 1/6W CARBON RES.	
	R153	QRD167J-223	22K 1/6W CARBON RES.	
	R155	QRD167J-223	22K 1/6W CARBON RES.	
	R156	QRD161J-473	47K 1/6W CARBON RES.	
	R157	QRD167J-332	3.3K 1/6W CARBON RES.	
	R158	QRD167J-332	3.3K 1/6W CARBON RES.	
	R159	QRD161J-392	3.9K 1/6W CARBON RES.	
	R160	QRD161J-392	3.9K 1/6W CARBON RES.	
	R161	QRD161J-102	1K 1/6W CARBON RES.	
	R162	QRD161J-102	1K 1/6W CARBON RES.	
	R163	QRD161J-472	4.7K 1/6W CARBON RES.	
	R164	QRD161J-472	4.7K 1/6W CARBON RES.	
	R167	QRD161J-102	1K 1/6W CARBON RES.	
	R168	QRD161J-470	47 1/6W CARBON RES.	
	R170	QRD161J-333	33K 1/6W CARBON RES.	
	R171	QRD167J-153	15K 1/6W CARBON RES.	
	R172	QRD161J-823	82K 1/6W CARBON RES.	
	R173	QRD161J-104	100K 1/6W CARBON RES.	
	R176	QRD161J-102	1K 1/6W CARBON RES.	
	R177	QRD161J-102	1K 1/6W CARBON RES.	
	R178	QRD161J-123	12K 1/6W CARBON RES.	
	R179	QRD167J-682	6.8K 1/6W CARBON RES.	
	R181	QRD161J-102	1K 1/6W CARBON RES.	
	R182	QRD161J-103	10K 1/6W CARBON RES.	
	R183	QRD161J-103	10K 1/6W CARBON RES.	
	R184	QRD161J-103	10K 1/6W CARBON RES.	
	VR101	QVPA601-103A	10K TRIMMER RES.	
	VR102	QVPA601-502A	5K TRIMMER RES.	
		OTHERS		
		EMW10684-003A	PRINTED BOARD	
	L111	EQL4007-150T	INDUCTOR	
	T111	EQR7121-006	RF COIL	
	T141	QQR0613-001	I. F. TRANSFORMER	
	T142	QAX0303-001	CERAMIC FILTER	
	T151	QQR0522-001	NOISE FILTER	
	X121	ECX0007-200KC	CRYSTAL	
	AT101	EMB41YV-302K	ANTENNA TERMINAL	
	BK001	E308963-223SM	SHIELD BRACKET	
	CF101	QAX0285-001Z	CERAMIC FILTER	
	CF102	QAX0285-001Z	CERAMIC FILTER	
	CN111	EMV5163-012R	CONNECT TERMINAL	
	FL141	EQF0101-013	LOWPASS FILTER	
	FL142	EQF0101-013	LOWPASS FILTER	
	RF101	EAF2302-002	FRONT END	

PARTS LIST

<XT-TD5/TD55R>

* All printed circuit boards and its assemblies are not available as service parts.

The Marks for Designated Areas

BS ---- the U.K.
 C ---- Canada
 EF ---- Continental Europe
 EN ---- Scandinavia
 G ---- Germany
 J ---- the U. S. A.
 UB ---- Hong Kong
 U ---- Universal Type
 UP ---- Korea
 US ---- Singapore
 UT ---- Taiwan
 VX ---- East Europe
 No marks indicates all areas.

- Contents -

General Exploded View and Parts List -----	5-3
CD Changer Mechanism Ass'y and Parts List-----	5-5
Chassette Mechanism Ass'y and Parts List -----	5-7
Chassette Loading Mechanism Ass'y and Parts -----	5-9
Electrical Parts List -----	5-11
(ENJ-099) -----	5-11
Accessories List -----	5-16
Packing Materials and Parts List -----	5-17

XT-TD5/XT-TD55R

General Exploded View and Parts List

Block No. **M2MM**

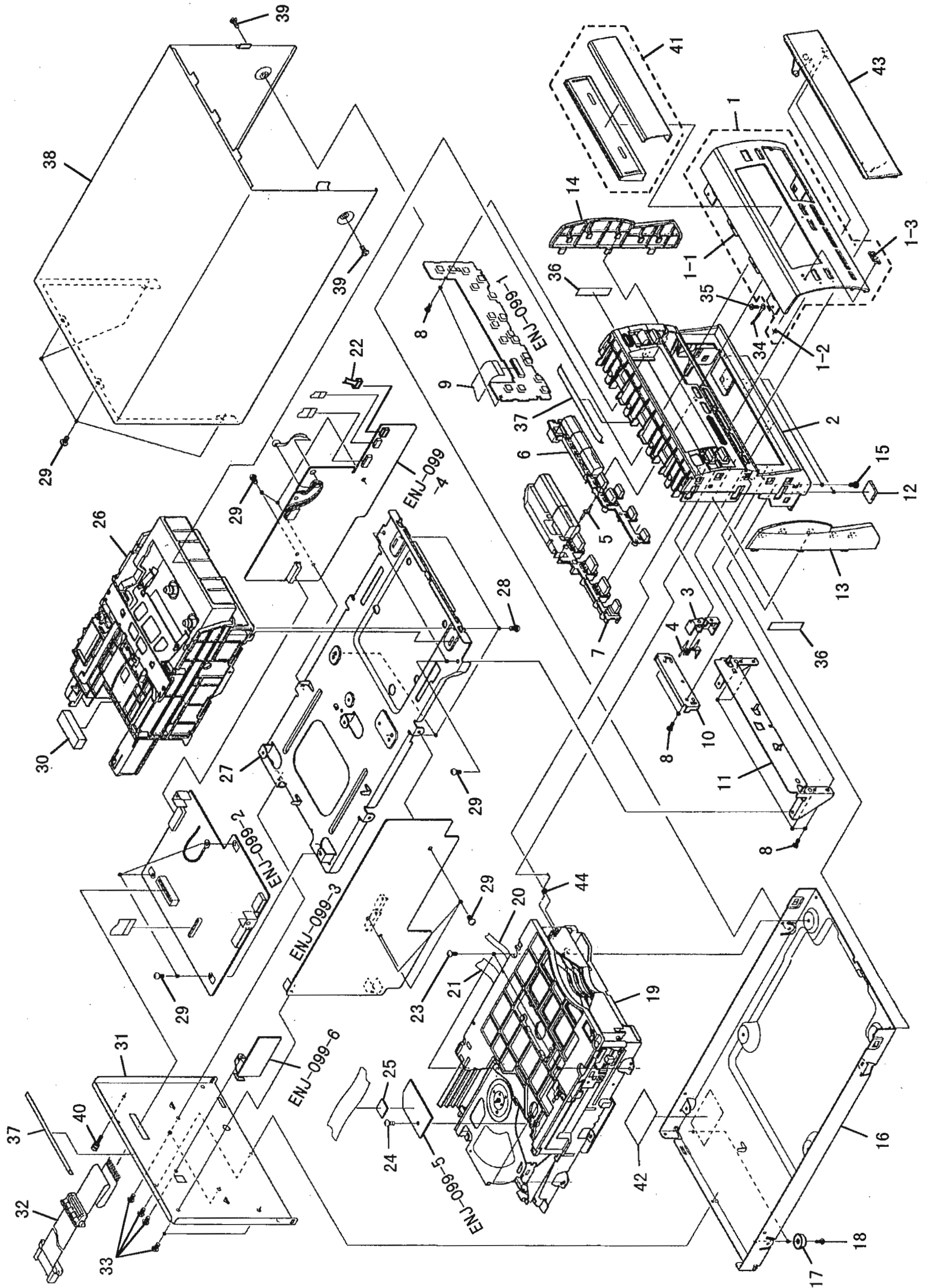

XT-TD5/XT-TD55R

■ Parts List (XT-TD5)

Block No. **M2MM**

△	Item	Parts Number	Parts Name	Q'ty	Description	Area
	1	EFP-XTTD5E(S)	FRONT PANEL ASSY	1		
	1-1	LE20101-001A	FRONT PANEL	1		
	1-2	E60912-003	SPEED NUT	1		
	1-3	E406971-221	JVC MARK	1		
	2	LE10067-001A	FRONT BASE	1		
	3	LE30380-001A	L. E. D. HOLDER	1		
	4	LE40126-002A	INDICATOR LENS	1	DOLBY	
	5	LE40127-002A	INDICATOR LENS	1	REC	
	6	LE20103-001A	PUSH BUTTON ASSY	1	PLAY	
	7	LE20106-003A	PUSH BUTTON ASSY	1	STOP	
	8	SDSF2608Z	SCREW	8		
	9	VWF1019-45TTA	FLAT WIRE	1		
	10	LE30340-001A	STAY BRACKET	1		
	11	LE30341-001A	STAY BRACKET	1		
	12	E75896-001	SPACER	2		
	13	LE20098-001A	SIDE FITTING	1		
	14	LE20099-001A	SIDE FITTING	1		
	15	SDSG3006CC	SCREW	2		
	16	LE10068-001A	CHASSIS BASE	1		
	17	E47227-029	FOOT	2		
	18	SBSG3008Z	TAPPING SCREW	2		
	19	-----	CHANGER MECHANISM ASSY	1	See page 5-4	
	20	VWF1007-12TTAX	FLAT WIRE	1	CN606-CN616	
	21	VWF1011-12TTAX	FLAT WIRE	1	CN605-CN615	
	22	EWS243-088	SOCKET WIRE ASSY	1	SC781	
	23	SBST3006CC	TAPPING SCREW	4		
	24	SBSF3006Z	TAPPING SCREW	1		
	25	E3400-431	FELT SPACER	1		
	26	-----	CASSETTE MECHANISM ASSY	1	See page 5-6, 9	
	27	LE10069-002A	CHASSIS BASE	1		
	28	SBSF3008Z	TAPPING SCREW	4		
	29	SBSG3008CC	TAPPING SCREW	16		
	30	LE30001-004A	SPACER	1		
	31	LE20109-001A	REAR PANEL	1		J
		LE20109-002A	REAR PANEL	1		C
		LE20109-003A	REAR PANEL	1		BS EF EN G
		LE20109-004A	REAR PANEL	1		VX
		LE20109-005A	REAR PANEL	1		U UB US UT
		LE20109-006A	REAR PANEL	1		UP
	32	EWP907-023	FLAT WIRE	1	SYSTEM WIRE	
	33	E73273-003	SPECIAL SCREW	6		
	34	EWT025-006	TERMINAL WIRE	1		
	35	SDSG3008Z	SCREW	1		
	36	LE30001-016A	SPACER	2		
	37	LE30001-017A	SPACER	2		
	38	LE20097-002A(S)	METAL COVER	1		
	39	SDSG3006N	TAPPING SCREW	2		
	40	E409257-001	EARTH TERMINAL	1		
	41	LE30342-001ASA	TRAY FITTING ASSY	1		
	42	E406507-001	LASER CAUTION	1		Except J
	43	LE20164-001A	CD FITTING	1		
	44	LE40133-002A	SPRING	1		
	-	E307570-001	NUMBER LABEL	1		J
		LET0074-001A	CAUTION SHEET	1		

■ Parts List (XT-TD55R)

* Please see the parts list of XT-TD5 for parts which are not described.

△	Item	Parts Number	Parts Name	Q'ty	Description	Area
	31	LE20109-011A	REAR PANEL	1		

CD Changer Mechanism Ass'y and Parts List

Block No. **M3MM**

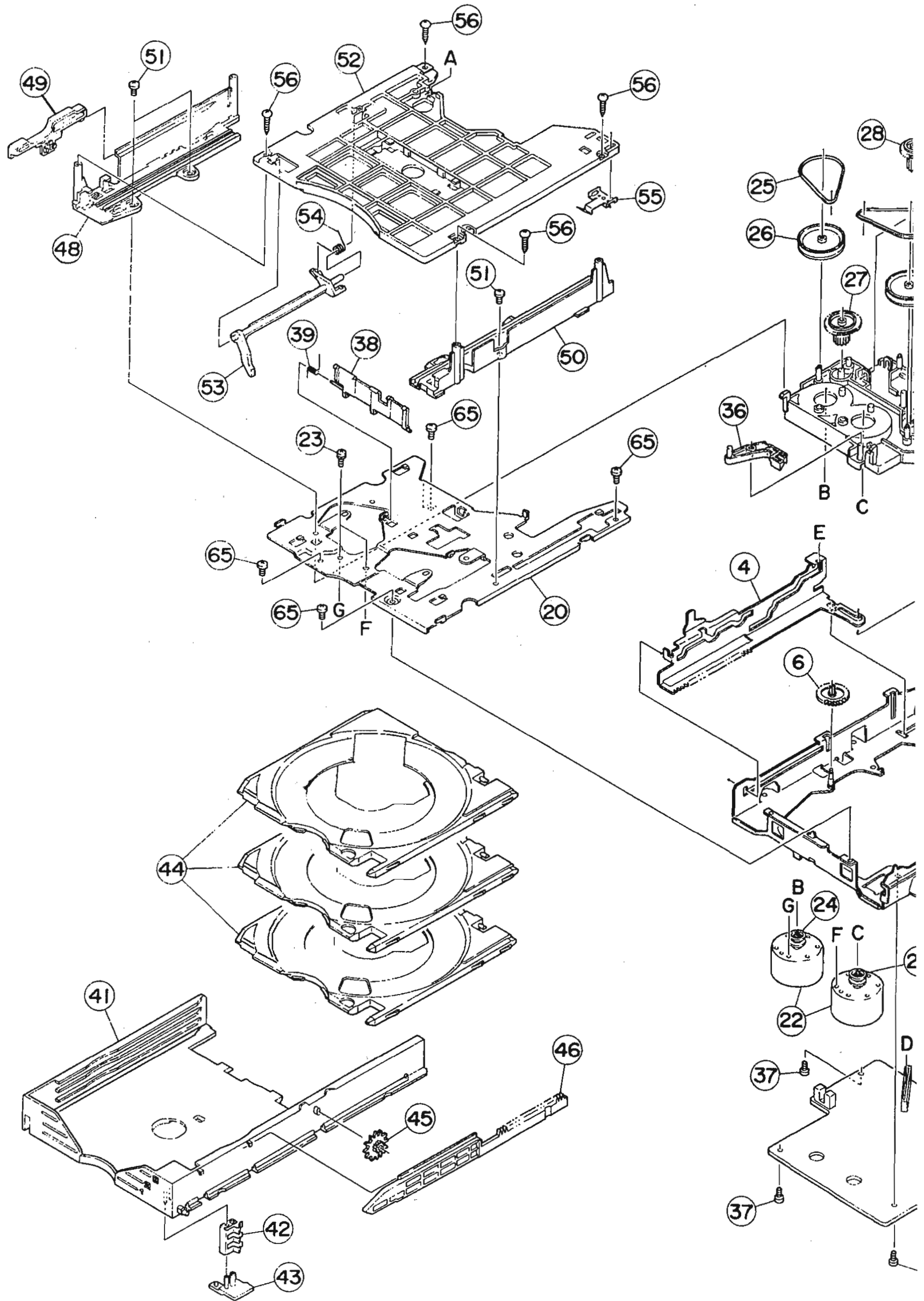

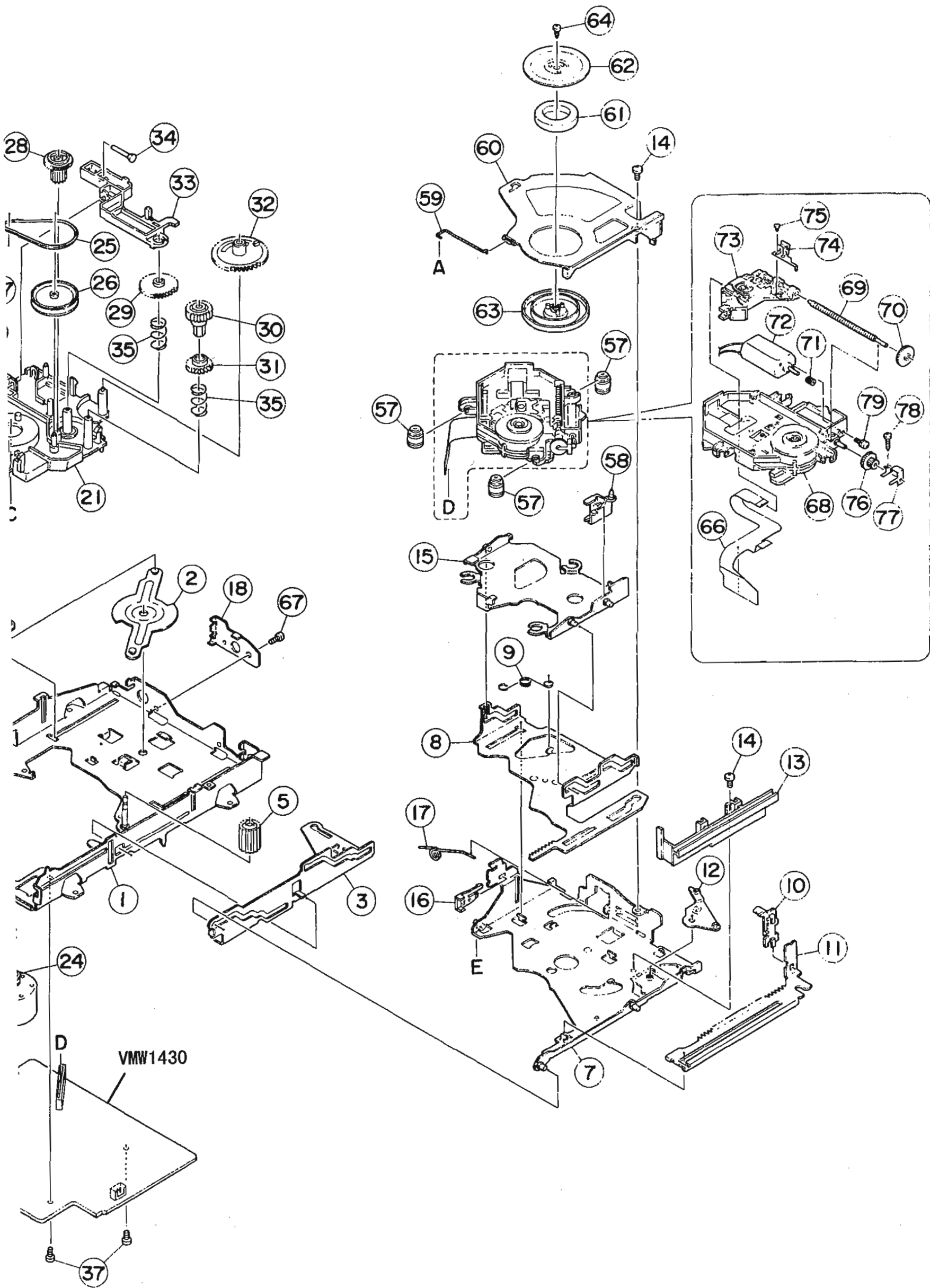

XT-TD5/XT-TD55R

■ Parts List (CD Changer Mechanism Ass'y)

Block No. **M3MM**

△	Item	Parts Number	Parts Name	Q'ty	Description	Area
	1	VKM3893-00B	CHASSIS BASE	1		
	2	VKL7846-00A	CONNECT ARM	1		
	3	VKL2763-001	SLIDE CAM	1		
	4	VKL2764-001	SLIDE CAM	1		
	5	VKS3765-001	HOOK GEAR	1		
	6	VKS3766-001	POSITION GEAR	1		
	7	VKM3895-00B	LIFTER BASE	1		
	8	VKL2766-004	LIFTER	1		
	9	VKW5245-002	DIRECTION SPRING	1		
	10	VKS3767-001	HOOK	1		
	11	VKM3896-001	SLIDER	1		
	12	VKM3897-001	LOCK ARM	1		
	13	VKS3768-001	GUIDE RAIL	1		
	14	SDST2605Z	SCREW	2		
	15	VKM3898-00C	FLOATING BASE	1		
	16	VKS3769-001	TRAY HOLDER	1		
	17	VKW5250-002	LEAF SPRING	1		
	18	VKL7881-002	PROTECTOR	1		
	20	VKL2768-001	TRAY BASE	1		
	21	VKS1162-001	ACTUATOR	1		
	22	MSN5G257A	DC MOTOR	2		
	23	LPSP2606Z	ASSY SCREW	2		
	24	VKS5548-001	MOTOR PULLEY	2		
	25	VKB3000-177	CAPSTAN BELT	2		
	26	VKS5549-001	PULLEY GEAR	2		
	27	VKS5550-001	THIRD GEAR	1		
	28	VKS5551-001	THIRD GEAR	1		
	29	VKS5552-001	ELEVATOR GEAR	1		
	30	VKS5553-001	TIMING GEAR	1		
	31	VKS5554-001	DOWN GEAR	1		
	32	VKS3770-001	SWITCH GEAR	1		
	33	VKS2269-001	ELEVATOR ARM	1		
	34	VKH5783-001	ELEVATOR PIN	1		
	35	VKW5246-001	ELEVATOR SPRING	2		
	36	VKS3772-001	SELECT LEVER	1		
	37	SDST2605Z	SCREW	4		
	38	VKS3773-001	LID PLATE	1		
	39	VKW5247-003	SPRING	1		
	41	VKS1157-001	DISK CASE	1		
	42	VKM3900-001	CLICK SPRING	1		
	43	VKS3774-001	SPRING COVER	1		
	44	VKS1158-001	SUB TRAY	3		
	45	VKS5555-001	PLANET GEAR	1		
	46	VKS3775-001	DOOR LEVER	1		
	48	VKS1159-001	TRAY GUIDE	1		
	49	VKS3777-001	SELECT SWITCH	1		
	50	VKS1160-001	TRAY GUIDE	1		
	51	SDST2605Z	SCREW	3		
	52	VKS1163-003	TOP COVER	1		
	53	VKS3778-001	SELECTOR	1		
	54	VKW5248-001	SELECTOR SPRING	1		
	55	VKM3901-001	CLICK SPRING	1		
	56	SBSF2608Z	TAPPING SCREW	2		

■ Parts List (CD Changer Mechanism Ass'y)

Block No. **M3MM**

△	Item	Parts Number	Parts Name	Q'ty	Description	Area
	57	VKZ4791-001	INSULATOR	3		
	58	VKS3779-001	STOPPER	1		
	59	VKW5249-001	ROD	1		
	60	VKL2769-002	CLAMPER BASE	1		
	61	VYH7313-003	MAGNET	1		
	62	VKL7757-001	YOKE PLATE	1		
	63	VKS3780-001	CLAMPER	1		
	64	SPSF2604Z	TAPPING SCREW	1		
	65	SDST2605Z	SCREW	4		
	66	VMW3699-001	F. P. C.	1		
	67	SDST2605Z	SCREW	1		
	68	VKS1161-002	MECHA CHASSIS ASSY	1		
	69	VKZ4781-001	SCREW SHAFT	1		
	70	VKS5556-001	FEED GEAR	1		
	71	VKS5557-001	LOADING GEAR	1		
	72	PPN-13KA10C	DC MOTOR ASSY	1		
	73	OPTIMA-610B1	OPTICAL PICK-UP	1		
	74	VKM3903-001	RACK ARM	1		
	75	SPSK1714M	SCREW	2		
	76	VKS5558-001	MIDDLE GEAR	1		
	77	VKM3904-001	SHAFT HOLDER	1		
	78	VKZ4248-206	TAPPING SCREW	1		
	79	LPSP2004Z	ASSY SCREW	1		

Cassette Mechanism Ass'y and Parts List

Block No. **M4MM**

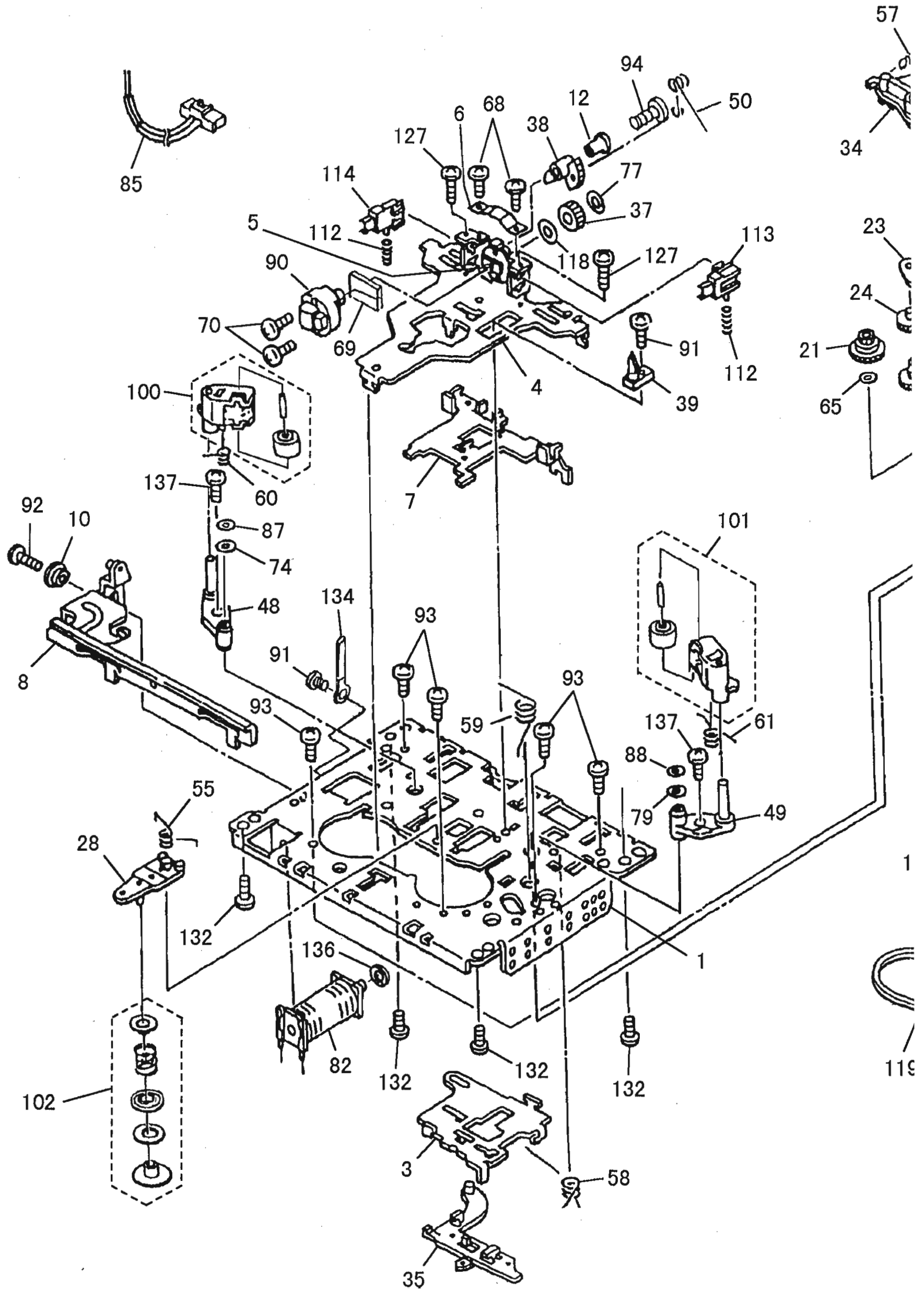

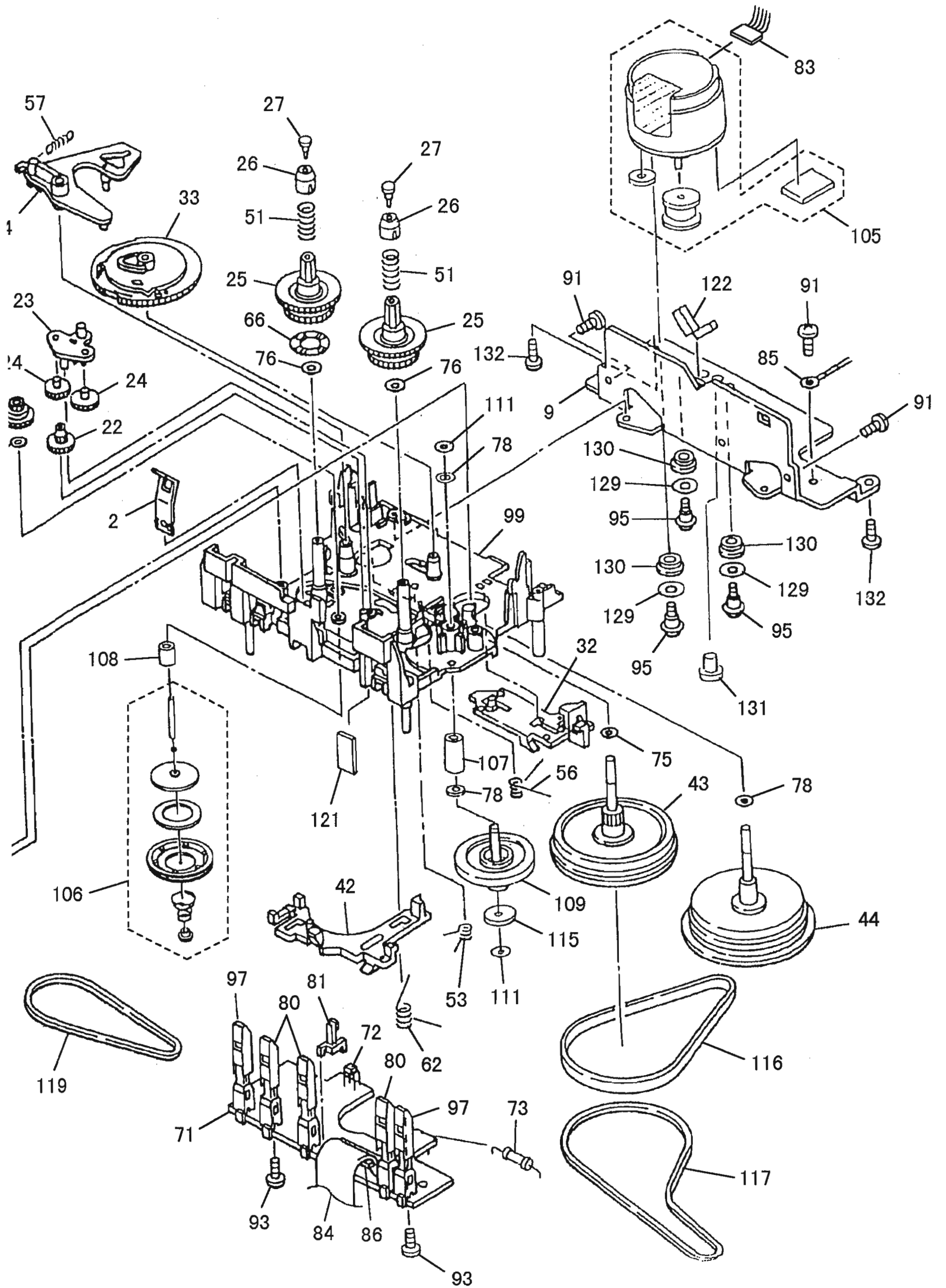

XT-TD5/XT-TD55R

■ Parts List (Cassette Mechanism Ass'y)

Block No. **M4MM**

△	Item	Parts Number	Parts Name	Q'ty	Description	Area
	1	EGS-FB1011	MECHA. BASE	1		
	2	EGS-FD1053	CASSETTE SPRING	1		
	3	EGS-FC1004	SHIFT LEVER	1		
	4	EGS-FD1036	HEAD BASE ASSY	1		
	5	EGS-FD1024	HEAD PLATE ASSY	1		
	6	EGS-FD1005	LEAF SPRING	1		
	7	EGS-FC1003	SHIFT LEVER	1		
	8	EGS-FCS1043	LEVER PLATE	1		
	9	EGS-FCS1042	MOTOR BRACKET	1		
	10	EGS-FD2023	COLLAR	1		
	12	EGS-FD2002	COLLAR	1		
	21	EGS-FD3018	CLUTCH GEAR	1		
	22	EGS-FD3015	REW GEAR	1		
	23	EGS-FD3016	F. R. ARM	1		
	24	EGS-FD3017	CAM GEAR	2		
	25	EGS-FD3014	REEL DISK	2		
	26	EGS-FC3037	REEL CAP	2		
	27	EGS-FDS3029	REEL CAP	2		
	28	EGS-FD3010	RELEASE ARM	1		
	32	EGS-FD3009	SHIFT LEVER	1		
	33	EGS-FC3002	CAM GEAR	1		
	34	EGS-FC3003	ACTION LEVER	1		
	35	EGS-FC3004	STOPPER ARM	1		
	37	EGS-PD3034	CAM GEAR	1		
	38	EGS-PD3033	TURN GEAR	1		
	39	EGS-FD3027	CASSETTE GUIDE	1		
	42	EGS-FC3008	STOPPER ARM	1		
	43	EGS-FC5013	FLYWHEEL RD (HK) ASSY	1		
	44	EGS-FDS5011	FLYWHEEL LD	1		
	48	EGS-FD5006	ROLLER ARM	1		
	49	EGS-FD5002	ROLLER ARM	1		
	50	EGS-PD6055	TORSHON SPRING	1		
	51	EGS-FD6023	REEL SPRING	2		
	53	EGS-FD6031	TORSHON SPRING	1		
	55	EGS-FD6002	TORSHON SPRING	1		
	56	EGS-FD6022	SHIFT LEVER SELECT SPRING	1		
	57	EGS-FD6005	TRIGGER ARM SPRING	1		
	58	EGS-FD6019	TORSHON SPRING	1		
	59	EGS-FD6018	TORSHON SPRING	1		
	60	EGS-FD6007	TORSHON SPRING	1		
	61	EGS-FD6008	TORSHON SPRING	1		
	62	EGS-FD6003	TORSHON	1		
	65	EGS-ED8002	POLYSLIDER WASHER	2		
	66	EGS-FD8002	REFLECT SEAL	1		
	68	EGS-FD80360	AZIMUTH SCREW	2		
	69	EGS-PD8011	SPACER	1		
	70	EGS-ZD8725	HEAD SCREW	2		
	71	EGS-FCS9054	PRINTED BOARD	1		
	72	EGS-PD9058	I. C. (PH. SENSOR)	1		
	73	QRD161J-152	CARBON RESISTER	1		
	74	EGS-8341118065	POLYSLIDER WASHER	1		
	75	EGS-8342123076	POLYSLIDER WASHER	1		
	76	EGS-FD8015	REEL FELT	2		

■ Parts List (Cassette Mechanism Ass'y)

Block No. **M4MM**

△	Item	Parts Number	Parts Name	Q'ty	Description	Area
	77	EGS-8541335018	LUMILER WASHER	1		
	78	EGS-8342121014	POLYSLIDER WASHER	3		
	79	EGS-8341116591	POLYSLIDER WASHER	1		
	80	EGS-94019090	LEAF SWITCH	3		
	81	EGS-94019087	LEAF SWITCH	1		
	82	EGS-FD9042	SOLENOID ASSY	1		
	83	EGS-FD9052	FLAT WIRE	1	4PIN	
	84	EGS-FD90553	FLAT WIRE	1	15PIN	
	85	EGS-FD9073	SOCKET WIRE ASSY	1	6PIN	
	86	EGS-E40424405	CONNECT TERMINAL	1		
	87	EGS-8340421023	NYLON WASHER	1		
	88	834-0419-002	NYLON WASHER	1		
	90	EGS-92070222	HEAD	1		
	91	8113112004	SCREW	5		
	92	SPST2006Z	SCREW	1		
	93	EGS-8114112006	SCREW	5		
	94	EGS-FD8023	POWER LOCK SCREW	1		
	95	EGSD8511	MOTOR SCREW	3		
	97	EGS-FD9040	LEAF SWITCH	2		
	99	EGS-FC3055	MECHA. BASE	1		
	100	EGS-FD3030	P. ROLLER ASSY	1		
	101	EGS-FD3031	P. ROLLER ASSY	1		
	102	EGS-FD3032	CAM GEAR ASSY	1		
	105	EGS-FC9068	DRIVE MOTOR ASSY	1		
	106	EGS-FC3056	CLUTCH ASSY	1		
	109	EGS-FDS5014	PULLEY ASSY	1		
	111	EGS-8341113899	POLYSLIDER WASHER	2		
	112	EGS-PD6009	TAPE GUIDE SPRING	2		
	113	EGS-FCS3042	TAPE GUIDE	1		
	114	EGS-FCS3043	TAPE GUIDE	1		
	115	EGS-8540419025	NYLON WASHER	1		
	116	EGS-FD4008	DRIVE BELT	1		
	117	EGS-FD4009	DRIVE BELT	1		
	118	EGS-8342144593	POLYSLIDER WASHER	1		
	119	EGS-FD4010	DRIVE BELT	1		
	121	EGS-FD8026	SPACER	1		
	122	EGS-FD8014	PROTECT SHEET	1		
	127	EGS-FD8022	BIND MACHINE SCREW	2		
	129	EGMD1270	WASHER	3		
	130	EGMD4002	MOTOR CUSHION	3		
	131	SPSP3003Z	SCREW	1		
	132	EGS-8114512608	SCREW	4		
	134	PU49485-3	CORD CLAMP	1		
	136	EGS-8341116095	POLY WASHER	1		
	137	SPST2004Z	SCREW	2		

Cassette Loading Mechanism Ass'y and Parts List

Block No. **M5MM**

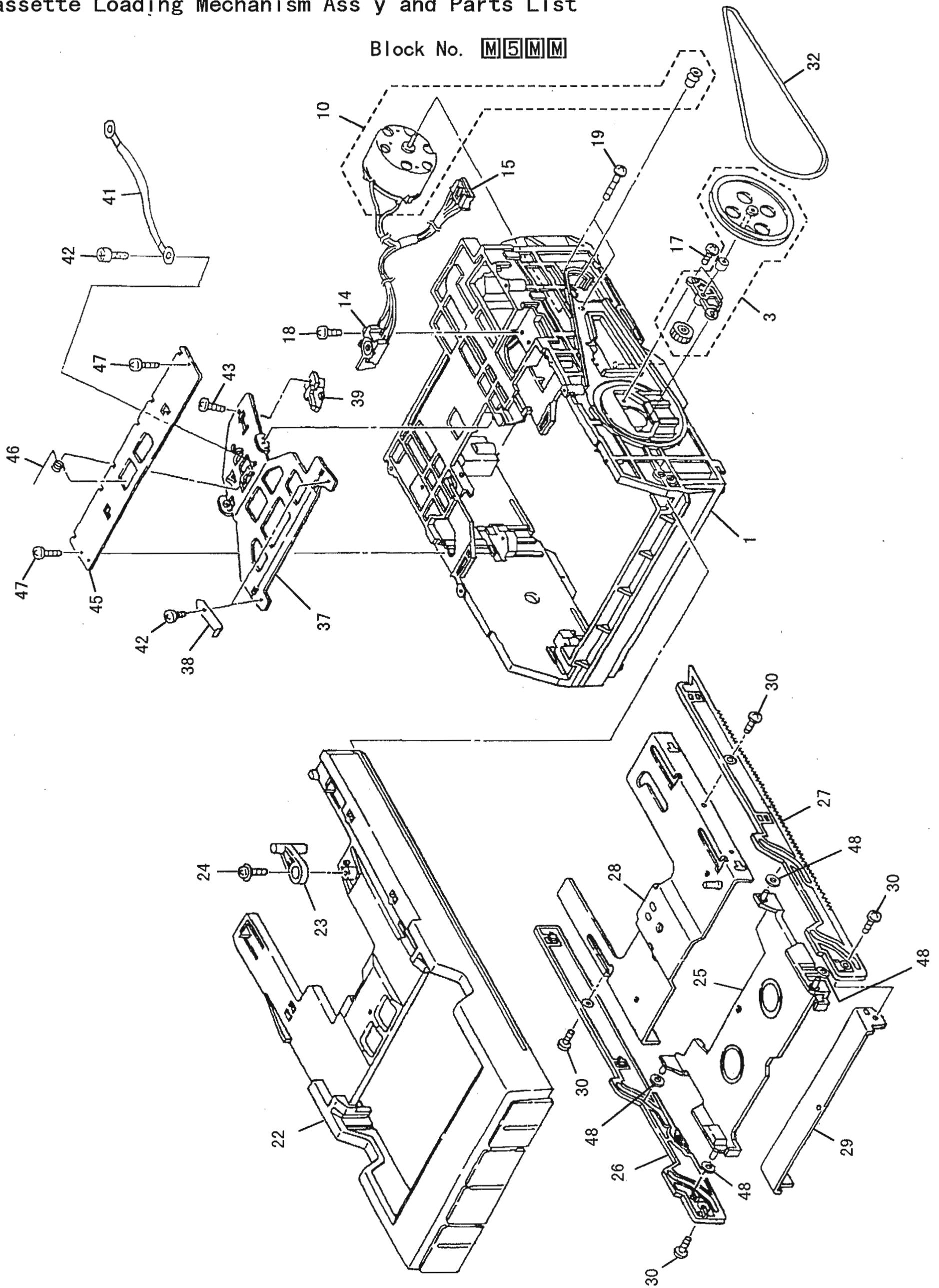

XT-TD5/XT-TD55R

■ Parts List (Cassette Loading Mechanism Ass'y)

Block No. **M5MM**

△	Item	Parts Number	Parts Name	Q'ty	Description	Area
	1	EGS-A10303708	MECHA BASE	1		
	3	EGS-D13153608	LOADING GEAR ASSY	1		
	10	EGS-T42063408	LOADING MOTOR ASSY	1		
	14	EGS-S33206105	LEVER SWITCH	1		
	15	EGS-FD9072	CONNECT. WIRE ASSY	1		
	17	SDSF2605Z	SCREW	2		
	18	SDSF2606M	SCREW	1		
	19	SDSP2604Z	SCREW	2		
	22	EGS-J99052308	TRAY	1		
	23	EGS-D10335908	ARM STOPPER	1		
	24	EGS-N09302505	SCREW	1		
	25	EGS-J99052408	TRAY	1		
	26	EGS-D10335708	SLIDER	1		
	27	EGS-D10335808	SLIDER	1		
	28	EGS-J21598108	TRAY BRACKET	1		
	29	EGS-J21598308	BRACKET	1		
	30	SDST2005Z	SCREW	4		
	32	EGS-D16034508	LOADING BELT	1		
	37	EGS-J11019108	CLAMPER PLATE	1		
	38	EGS-G02101908	LEAF SPRING	2		
	39	EGS-J90070008	CLAMPER GUIDE	1		
	41	EGS-E35072008	EARTH WIRE	1		
	42	SDST2003Z	SCREW	3		
	43	SDSF2006Z	SCREW	1		
	45	EGS-F39006508	CLAMPER BRACKET	1		
	46	EGS-G01355408	TORSHON SPRING	1		
	47	SDSF2008Z	SCREW	2		
	48	EGS-8342126017	POLY WASHER	4		

Electrical Parts List (ENJ-099)

△	Item	Parts Number	Description	Area
		I. C. S		
	IC502	NJM4558D-D	I. C (MONO-ANALOG)	
	IC541	HA12206NT	I. C (MONO-ANALOG)	
	IC561	HA12136A	I. C (MONO-ANALOG)	
	IC731	TC4052BP	I. C (DIGI-MOS)	
	IC732	NJM4580DD	I. C (MONO-ANALOG)	
	IC751	MN172412JAAZ	I. C (MICRO-COMPUTER)	
	IC752	MN1381 (P, Q) TA	I. C (DIGI-MOS)	
	IC775	LB1641	I. C (DIGI-OTHER)	
		DIODES		
	D501	1SS133	SI. DIODE	BS EF EN G VX
	D521	1SS133	SI. DIODE	
	D522	MTZ11JC	ZENER DIODE	
	D555	MTZ7.5JC	ZENER DIODE	
	D556	MTZ7.5JC	ZENER DIODE	
	D581	1SS133	SI. DIODE	
	D582	1SS133	SI. DIODE	
	D583	1SS133	SI. DIODE	
	D584	1SS133	SI. DIODE	
	D585	1SS133	SI. DIODE	
	D589	1SS133	SI. DIODE	
	D701	MTZ8.2JC	ZENER DIODE	
	D711	MTZ5.6JC	ZENER DIODE	
	D712	1SS133	SI. DIODE	
△	D721	11E2	SI. DIODE	
	D731	MTZ7.5JC	ZENER DIODE	
	D732	MTZ7.5JC	ZENER DIODE	
	D751	1SS133	SI. DIODE	
	D760	1SS133	SI. DIODE	
	D761	1SS133	SI. DIODE	
	D762	1SS133	SI. DIODE	
	D763	1SS133	SI. DIODE	
	D764	1SS133	SI. DIODE	
	D781	SLR-342DCA47	L. E. D.	
	D782	SLR-342DCA47	L. E. D.	
	D783	SLR-342DCA47	L. E. D.	
	D784	SLR-342DCA47	L. E. D.	
	D785	SLR-342DCA47	L. E. D.	
	D786	SLR-342DCA47	L. E. D.	
	D787	SLR-342DCA47	L. E. D.	
	D788	SLR-342DCA47	L. E. D.	
	D789	SLR-342DCA47	L. E. D.	
	D790	SLR-342DCA47	L. E. D.	
	D791	SLR-342VC3F	L. E. D.	
	D792	SLR-342VC3F	L. E. D.	
	D793	SLR-342VC3F	L. E. D.	
		TRANSISTORS		
	Q501	2SC1740S (R, S)	SI. TRANSISTOR	BS EF EN G VX
	Q502	KRA104M-T	DIGITAL TRANSISTOR	BS EF EN G VX
	Q521	2SC1740S (R, S)	SI. TRANSISTOR	
	Q522	2SC1740S (R, S)	SI. TRANSISTOR	
	Q523	2SC1740S (R, S)	SI. TRANSISTOR	
	Q524	2SC1740S (R, S)	SI. TRANSISTOR	
	Q525	2SC2060 (Q, R)	SI. TRANSISTOR	
	Q581	2SK373 (O, Y)	F. E. T.	
	Q582	2SK373 (O, Y)	F. E. T.	
	Q583	KRA104M-T	DIGITAL TRANSISTOR	
	Q584	KRA104M-T	DIGITAL TRANSISTOR	
	Q585	2SD2144S (VW)	SI. TRANSISTOR	
	Q586	2SD2144S (VW)	SI. TRANSISTOR	
	Q701	2SD2037 (E, F)	SI. TRANSISTOR	
	Q711	2SC2060 (Q, R)	SI. TRANSISTOR	
	Q712	2SB1565 (E, F)	SI. TRANSISTOR	
	Q713	KRC102M-T	DIGITAL TRANSISTOR	
	Q715	2SD2144S (VW)	SI. TRANSISTOR	
	Q716	2SD2144S (VW)	SI. TRANSISTOR	
	Q717	KRA104M-T	DIGITAL TRANSISTOR	
	Q721	2SC1741AS (QR)	SI. TRANSISTOR	

△	Item	Parts Number	Description	Area
	Q723	2SD400MP (E, F)	SI. TRANSISTOR	
	Q724	KRC104M-T	DIGITAL TRANSISTOR	
	Q731	2SD2144S (VW)	SI. TRANSISTOR	
	Q732	2SD2144S (VW)	SI. TRANSISTOR	
	Q733	KRA104M-T	DIGITAL TRANSISTOR	
	Q781	KRC102M-T	DIGITAL TRANSISTOR	
	Q782	KRC102M-T	DIGITAL TRANSISTOR	
	Q783	KRC102M-T	DIGITAL TRANSISTOR	
	Q784	KRC102M-T	DIGITAL TRANSISTOR	
	Q785	KRC102M-T	DIGITAL TRANSISTOR	
		CAPACITORS		
	C501	QCBB1HK-331Y	330PF 50V CER. CAP.	
	C502	QCBB1HK-331Y	330PF 50V CER. CAP.	
	C503	QCBB1HK-102Y	1000PF 50V CER. CAP.	
	C504	QCBB1HK-102Y	1000PF 50V CER. CAP.	
	C505	QETB1HM-225	2.2MF 50V AL E. CAP.	
	C506	QETB1HM-225	2.2MF 50V AL E. CAP.	
	C507	QCBB1HK-101Y	100PF 50V CER. CAP.	C J U UB UP US UT
		QCSB1HJ-560Y	56PF 50V CER. CAP.	BS EF EN G VX
	C508	QCBB1HK-101Y	100PF 50V CER. CAP.	C J U UB UP US UT
		QCSB1HJ-560Y	56PF 50V CER. CAP.	BS EF EN G VX
	C509	QETC1AM-107ZN	100MF 10V E. CAP.	
	C510	QETC1AM-107ZN	100MF 10V E. CAP.	
	C511	QFLB1HJ-103	0.01MF 50V MYLAR CAP.	
	C512	QFLB1HJ-103	0.01MF 50V MYLAR CAP.	
	C513	QETB1HM-225	2.2MF 50V AL E. CAP.	
	C514	QETB1HM-225	2.2MF 50V AL E. CAP.	
	C515	QETB1CM-476	47MF 16V AL E. CAP.	
	C516	QETB1CM-476	47MF 16V AL E. CAP.	
	C517	QCY41HK-561	560PF 50V CER. CAP.	BS EF EN G VX
	C521	QETB1HM-105	1MF 50V AL E. CAP.	
	C522	QFLB1HJ-682	6800PF 50V MYLAR CAP.	
	C523	QFLB1HJ-332	3300PF 50V MYLAR CAP.	
	C524	QFLB1HJ-332	3300PF 50V MYLAR CAP.	
	C525	QFLB1HJ-183	0.018MF 50V MYLAR CAP.	
	C526	QETB1HM-105	1MF 50V AL E. CAP.	
	C527	QETB1EM-106	10MF 25V AL E. CAP.	
	C528	QETB1CM-107	100MF 16V AL E. CAP.	
	C529	QCBB1HK-221Y	220PF 50V CER. CAP.	BS EF EN G VX
	C530	QFP31HJ-472Z	4700PF 50V POLYPROP. FI	
	C531	QCBB1HK-101Y	100PF 50V CER. CAP.	
	C532	QCBB1HK-101Y	100PF 50V CER. CAP.	
	C533	QETB1CM-226	22MF 16V E. CAP.	
	C534	QETB1EM-106	10MF 25V AL E. CAP.	
	C535	QCBB1HK-101Y	100PF 50V CER. CAP.	
	C536	QCBB1HK-101Y	100PF 50V CER. CAP.	
	C541	QFLB1HJ-472	4700PF 50V MYLAR CAP.	
	C542	QFLB1HJ-472	4700PF 50V MYLAR CAP.	
	C543	QETB1HM-225	2.2MF 50V AL E. CAP.	
	C544	QETB1HM-225	2.2MF 50V AL E. CAP.	
	C545	QFV81HJ-104	0.1MF 50V THIN FILM CA	
	C546	QFV81HJ-104	0.1MF 50V THIN FILM CA	
	C547	QETB1HM-225	2.2MF 50V AL E. CAP.	
	C548	QETB1HM-225	2.2MF 50V AL E. CAP.	
	C551	QCBB1HK-821Y	820PF 50V CER. CAP.	
	C552	QETB1HM-474	0.47MF 50V E. CAP.	
	C553	QETB1CM-476	47MF 16V AL E. CAP.	
	C555	QETB1CM-476	47MF 16V AL E. CAP.	
	C556	QETB1CM-476	47MF 16V AL E. CAP.	
	C557	QCXB1CM-472Y	4700PF 16V CER. CAP.	
	C558	QCXB1CM-472Y	4700PF 16V CER. CAP.	
	C561	QFLB1HJ-103	0.01MF 50V MYLAR CAP.	
	C562	QFLB1HJ-103	0.01MF 50V MYLAR CAP.	
	C563	QCBB1HK-221Y	220PF 50V CER. CAP.	BS EF EN G VX
	C564	QCBB1HK-221Y	220PF 50V CER. CAP.	BS EF EN G VX
	C565	QETB1HM-225	2.2MF 50V AL E. CAP.	
	C566	QETB1HM-225	2.2MF 50V AL E. CAP.	
	C567	QETB1HM-225	2.2MF 50V AL E. CAP.	

XT-TD5/XT-TD55R

Electrical Parts List (ENJ-099)

△	Item	Parts Number	Description	Area
	C568	QETB1HM-225	2.2MF 50V AL E. CAP.	
	C571	QFV81HJ-224	0.22MF 50V THIN FILM CA	
	C572	QFV81HJ-224	0.22MF 50V THIN FILM CA	
	C573	QETB1HM-226E	22MF 50V E. CAP.	
	C574	QETB1HM-226E	22MF 50V E. CAP.	
	C575	QETB1HM-475E	4.7MF 50V E. CAP.	
	C576	QETB1CM-476	47MF 16V AL E. CAP.	
	C577	QETB1CM-226	22MF 16V E. CAP.	
	C581	QETB1CM-107	100MF 16V AL E. CAP.	
	C591	QCHB1EZ-223	0.022MF 25V CER. CAP.	BS EF EN G VX
	C592	QCHB1EZ-223	0.022MF 25V CER. CAP.	BS EF EN G VX
	C701	QETB1CM-226	22MF 16V E. CAP.	
	C702	QETB1AM-108	1000MF 10V E. CAP.	
	C703	QCF21HP-103A	0.01MF 50V CER. CAP.	
	C711	QETBOJM-107	100MF 6.3V AL E. CAP.	
	C712	QCF21HP-103A	0.01MF 50V CER. CAP.	
	C713	QETB1AM-226	22MF 10V E. CAP.	
	C731	QETB1EM-476	47MF 25V AL E. CAP.	
	C732	QETB1EM-476	47MF 25V AL E. CAP.	
	C733	QCY31HK-472Z	4700PF 50V CER. CAP.	
	C734	QCY31HK-472Z	4700PF 50V CER. CAP.	
	C735	QCY31HK-821Z	820PF 50V CER. CAP.	
	C736	QCY31HK-821Z	820PF 50V CER. CAP.	
	C737	EETB1HM-105E	1MF 50V E. CAP.	
	C738	EETB1HM-105E	1MF 50V E. CAP.	
	C745	QCHB1EZ-223	0.022MF 25V CER. CAP.	
	C746	QCHB1EZ-223	0.022MF 25V CER. CAP.	
	C751	QETB1CM-476	47MF 16V AL E. CAP.	
	C752	QCZ0202-155	1.5MF 25V CER. RES.	
	C753	QCHB1EZ-223	0.022MF 25V CER. CAP.	
	C754	QETBOJM-107	100MF 6.3V AL E. CAP.	
	C755	QCBB1HK-331Y	330PF 50V CER. CAP.	
	C756	QCBB1HK-101Y	100PF 50V CER. CAP.	
	C757	QCXB1CM-562Y	5600PF 16V CER. CAP.	
	C775	QETB1AM-477	470MF 10V E. CAP.	
	C776	QCHB1EZ-223	0.022MF 25V CER. CAP.	
	C777	QFLB1HJ-103	0.01MF 50V MYLAR CAP.	
	C781	QFV81HJ-104	0.1MF 50V THIN FILM CA	
	C791	QFLB1HJ-223	0.022MF 50V MYLAR CAP.	BS EF EN G VX
	C792	QFLB1HJ-223	0.022MF 50V MYLAR CAP.	BS EF EN G VX
	C793	QFLB1HJ-103	0.01MF 50V MYLAR CAP.	
	C799	QFLB1HJ-103	0.01MF 50V MYLAR CAP.	
		RESISTORS		
	R501	QRD161J-100	10 1/6W CARBON RES.	
	R502	QRD161J-100	10 1/6W CARBON RES.	
	R503	QRD161J-104	100K 1/6W CARBON RES.	
	R504	QRD161J-104	100K 1/6W CARBON RES.	
	R505	QRD161J-221	220 1/6W CARBON RES.	
	R506	QRD161J-221	220 1/6W CARBON RES.	
	R507	QRD161J-224	220K 1/6W CARBON RES.	
	R508	QRD161J-224	220K 1/6W CARBON RES.	
	R509	QRD161J-183	18K 1/6W CARBON RES.	
	R510	QRD161J-183	18K 1/6W CARBON RES.	
	R511	QRD161J-221	220 1/6W CARBON RES.	
	R512	QRD161J-221	220 1/6W CARBON RES.	
	R513	QRD161J-470	47 1/6W CARBON RES.	BS EF EN G VX
	R514	QRD161J-470	47 1/6W CARBON RES.	BS EF EN G VX
	R515	QRD161J-221	220 1/6W CARBON RES.	BS EF EN G VX
	R517	QRD161J-561	560 1/6W CARBON RES.	BS EF EN G VX
	R521	QRD161J-222	2.2K 1/6W CARBON RES.	
	R522	QRD167J-332	3.3K 1/6W CARBON RES.	
	R523	QRD161J-104	100K 1/6W CARBON RES.	
	R524	QRD161J-181	180 1/6W CARBON RES.	
	R525	QRD167J-511	510 1/6W CARBON RES.	
	R526	QRD161J-561	560 1/6W CARBON RES.	
	R527	QRD161J-393	39K 1/6W CARBON RES.	
	R528	QRD161J-393	39K 1/6W CARBON RES.	
	R529	QRD14CJ-6R8SX	6.8 1/4W UNF. CARBON R	

△	Item	Parts Number	Description	Area
	R531	QRD161J-101	100 1/6W CARBON RES.	
△	R532	QRD14CJ-100SX	10 1/4W UNF. CARBON R	J
△		QRZ0077-100	10 1/4W FUSIBLE RES.	Except J
	R535	QRD167J-153	15K 1/6W CARBON RES.	
	R536	QRD167J-153	15K 1/6W CARBON RES.	
	R541	QRD161J-333	33K 1/6W CARBON RES.	
	R542	QRD161J-333	33K 1/6W CARBON RES.	
	R543	QRD161J-242	2.4K 1/6W CARBON RES.	
	R544	QRD161J-242	2.4K 1/6W CARBON RES.	
	R551	QRD161J-563	56K 1/6W CARBON RES.	
	R552	QRD161J-184	180K 1/6W CARBON RES.	
	R553	QRD161J-105	1M 1/6W CARBON RES.	
	R555	QRD161J-221	220 1/6W CARBON RES.	
	R556	QRD161J-221	220 1/6W CARBON RES.	
	R557	QRD161J-102	1K 1/6W CARBON RES.	
	R558	QRD161J-102	1K 1/6W CARBON RES.	
	R561	QRD167J-153	15K 1/6W CARBON RES.	
	R562	QRD167J-153	15K 1/6W CARBON RES.	
	R563	QRD167J-153	15K 1/6W CARBON RES.	
	R564	QRD167J-153	15K 1/6W CARBON RES.	
	R565	QRD167J-153	15K 1/6W CARBON RES.	
	R566	QRD167J-153	15K 1/6W CARBON RES.	
	R567	QRD161J-681	680 1/6W CARBON RES.	
	R568	QRD161J-681	680 1/6W CARBON RES.	
	R569	QRD161J-183	18K 1/6W CARBON RES.	
	R570	QRD161J-103	10K 1/6W CARBON RES.	
	R571	QRD161J-183	18K 1/6W CARBON RES.	
△	R572	QRD14CJ-220S	22 1/4W UNF. CARBON R	
	R581	QRD161J-475	4.7M 1/6W CARBON RES.	
	R582	QRD161J-475	4.7M 1/6W CARBON RES.	
	R583	QRD161J-105	1M 1/6W CARBON RES.	
	R584	QRD161J-105	1M 1/6W CARBON RES.	
	R585	QRD161J-473	47K 1/6W CARBON RES.	
	R587	QRD161J-103	10K 1/6W CARBON RES.	
	R588	QRD161J-103	10K 1/6W CARBON RES.	
	R589	QRD161J-103	10K 1/6W CARBON RES.	
	R595	QRD167J-223	22K 1/6W CARBON RES.	
	R700	QRD161J-102	1K 1/6W CARBON RES.	
	R702	QRD161J-561	560 1/6W CARBON RES.	
	R703	QRD161J-221	220 1/6W CARBON RES.	
	R704	QRD161J-221	220 1/6W CARBON RES.	
△	R705	QRD12CJ-2R2SX	2.2 1/2W UNF. CARBON R	
	R706	QRD161J-221	220 1/6W CARBON RES.	
	R707	QRD161J-221	220 1/6W CARBON RES.	
	R708	QRD161J-221	220 1/6W CARBON RES.	
	R712	QRD167J-151	150 1/6W CARBON RES.	
	R713	QRD161J-103	10K 1/6W CARBON RES.	
	R714	QRD161J-471	470 1/6W CARBON RES.	
	R715	QRD161J-103	10K 1/6W CARBON RES.	
	R716	QRD161J-103	10K 1/6W CARBON RES.	
	R717	QRD161J-102	1K 1/6W CARBON RES.	
	R718	QRD161J-102	1K 1/6W CARBON RES.	
	R719	QRD161J-123	12K 1/6W CARBON RES.	
	R720	QRD161J-123	12K 1/6W CARBON RES.	
	R721	QRD161J-182	1.8K 1/6W CARBON RES.	
	R724	QRD161J-102	1K 1/6W CARBON RES.	
	R727	QRD161J-473	47K 1/6W CARBON RES.	
	R728	QRD161J-821	820 1/6W CARBON RES.	
	R729	QRD161J-473	47K 1/6W CARBON RES.	
	R731	QRD161J-471	470 1/6W CARBON RES.	
	R732	QRD161J-471	470 1/6W CARBON RES.	
	R737	QRD161J-222	2.2K 1/6W CARBON RES.	
	R738	QRD161J-222	2.2K 1/6W CARBON RES.	
	R739	QRD161J-222	2.2K 1/6W CARBON RES.	
	R740	QRD161J-222	2.2K 1/6W CARBON RES.	
	R741	QRD161J-104	100K 1/6W CARBON RES.	
	R742	QRD161J-104	100K 1/6W CARBON RES.	
	R743	QRD161J-221	220 1/6W CARBON RES.	

Electrical Parts List (ENJ-099)

△	Item	Parts Number	Description	Area
	R744	QRD161J-221	220 1/6W CARBON RES.	
	R745	QRD161J-271	270 1/6W CARBON RES.	
	R746	QRD161J-271	270 1/6W CARBON RES.	
	R747	QRD161J-103	10K 1/6W CARBON RES.	
	R748	QRD161J-103	10K 1/6W CARBON RES.	
	R751	QRD161J-105	1M 1/6W CARBON RES.	
	R752	QRD161J-821	820 1/6W CARBON RES.	
	R754	QRD161J-221	220 1/6W CARBON RES.	
	R755	QRD161J-221	220 1/6W CARBON RES.	
	R756	QRD161J-221	220 1/6W CARBON RES.	
	R757	QRD161J-221	220 1/6W CARBON RES.	
	R758	QRD161J-221	220 1/6W CARBON RES.	
	R761	QRD161J-472	4.7K 1/6W CARBON RES.	
	R762	QRD161J-472	4.7K 1/6W CARBON RES.	
	R763	QRD161J-472	4.7K 1/6W CARBON RES.	
	R764	QRD161J-472	4.7K 1/6W CARBON RES.	
	R765	QRD161J-472	4.7K 1/6W CARBON RES.	
	R766	QRD161J-102	1K 1/6W CARBON RES.	
	R767	QRD161J-103	10K 1/6W CARBON RES.	
	R768	QRD161J-103	10K 1/6W CARBON RES.	
	R769	QRD161J-103	10K 1/6W CARBON RES.	
	R770	QRD161J-103	10K 1/6W CARBON RES.	
	R771	QRD161J-472	4.7K 1/6W CARBON RES.	
	R772	QRD161J-472	4.7K 1/6W CARBON RES.	
	R773	QRD161J-103	10K 1/6W CARBON RES.	
	R774	QRD161J-103	10K 1/6W CARBON RES.	
	R775	QRD161J-222	2.2K 1/6W CARBON RES.	
	R776	QRD161J-392	3.9K 1/6W CARBON RES.	
	R777	QRD161J-103	10K 1/6W CARBON RES.	
	R778	QRD161J-103	10K 1/6W CARBON RES.	
	R779	QRD161J-103	10K 1/6W CARBON RES.	
	R780	QRD161J-103	10K 1/6W CARBON RES.	
	R781	QRD161J-271	270 1/6W CARBON RES.	
	R782	QRD161J-271	270 1/6W CARBON RES.	
	R783	QRD161J-271	270 1/6W CARBON RES.	
	R784	QRD161J-271	270 1/6W CARBON RES.	
	R785	QRD161J-271	270 1/6W CARBON RES.	
	R786	QRD161J-271	270 1/6W CARBON RES.	
	R787	QRD161J-271	270 1/6W CARBON RES.	
	R789	QRD161J-271	270 1/6W CARBON RES.	
	R791	QRD161J-271	270 1/6W CARBON RES.	
	R792	QRD161J-271	270 1/6W CARBON RES.	
	R793	QRD161J-271	270 1/6W CARBON RES.	
	VR501	QVPA603-104A	100K TRIMMER RES.	
	VR502	QVPA603-104A	100K TRIMMER RES.	
	VR503	QVPA603-501A	500 TRIMMER RES.	
	VR504	QVPA603-501A	500 TRIMMER RES.	
	VR531	QVPA603-104A	100K TRIMMER RES.	
	VR532	QVPA603-104A	100K TRIMMER RES.	
	VR561	QVPA603-503A	50K VARIABLE RE	
	VR562	QVPA603-503A	50K VARIABLE RE	
	VR722	QVPA603-222A	2.2K TRIMMER RES.	
		OTHERS		
		EMW10708-003	PRINTED BOARD	
	J781	TOTX178	OPTICAL JACK	
	K501	ENZ8101-007	INDUCTOR	BS EF EN G VX
	K502	ENZ8101-007	INDUCTOR	BS EF EN G VX
	K503	ENZ8101-007	INDUCTOR	BS EF EN G VX
	K724	ENZ8101-007	INDUCTOR	
	K726	ENZ8101-007	INDUCTOR	
	L521	ENZ6002-012	OSCILLATOR COIL	
	L535	EQL2106-223	INDUCTOR	
	L536	EQL2106-223	INDUCTOR	
	S501	QSS7A12-E01	SLIDE SWITCH	BS EF EN G VX
	S781	ESP0001-023M	TACT SWITCH	
	S782	ESP0001-023M	TACT SWITCH	
	S783	ESP0001-023M	TACT SWITCH	
	S784	ESP0001-023M	TACT SWITCH	

△	Item	Parts Number	Description	Area
	S785	ESP0001-023M	TACT SWITCH	
	S786	ESP0001-023M	TACT SWITCH	
	S787	ESP0001-023M	TACT SWITCH	
	S788	ESP0001-023M	TACT SWITCH	
	S789	ESP0001-023M	TACT SWITCH	
	S790	ESP0001-023M	TACT SWITCH	
	S791	ESP0001-023M	TACT SWITCH	
	S792	ESP0001-023M	TACT SWITCH	
	S793	ESP0001-023M	TACT SWITCH	
	S794	ESP0001-023M	TACT SWITCH	
	S795	ESP0001-023M	TACT SWITCH	
	S796	ESP0001-023M	TACT SWITCH	
	S797	ESP0001-023M	TACT SWITCH	
	S798	ESP0001-023M	TACT SWITCH	
	X751	ECX0060-000EM	CERAMIC RESONATOR	
	CN501	EMV5109-006B	CONNECT TERMINAL	
	CN502	EMV7141-015	PIN CONNECTOR	
	CN503	VMC0314-S10	CONNECT TERMINAL	
	CN504	VMC0314-S16	CONNECT TERMINAL	
	CN513	VMC0314-P10	CONNECT TERMINAL	
	CN514	VMC0314-P16	CONNECT TERMINAL	
	CN614	VMC0041-003	CONNECTOR	
	CN615	EMV7171-111R	CONNECTOR	
	CN616	EMV7171-107R	CONNECTOR	
	CN701	EMV7141-017	CONNECT TERMINAL	
	CN702	VMC0314-P16	CONNECT TERMINAL	
	CN703	EMV5109-005B	CONNECT TERMINAL	
	CN712	VMC0314-S16	CONNECT TERMINAL	
	CN781	EMV7171-119R	CONNECTOR	
	CN791	EMV7171-119	CONNECTOR	
△	CP701	ICP-N20	I. C. PROTECTOR	
	EP501	EMZ4002-002Z	EARTH PLATE	
	EP511	E409182-001SM	EARTH TERMINAL	
	EP512	E409182-001SM	EARTH TERMINAL	
	EP701	EMZ4002-002Z	EARTH PLATE	
	EP702	EMZ4002-002Z	EARTH PLATE	
	EP703	EMZ4002-002Z	EARTH PLATE	
	EP711	EMZ4002-002Z	EARTH PLATE	
	EP712	EMZ4002-002Z	EARTH PLATE	
	EP713	EMZ4002-002Z	EARTH PLATE	
	EP811	E409182-001SM	EARTH TERMINAL	
	EP812	E409182-001SM	EARTH TERMINAL	
	FW781	EWR33D-20SS	FLAT WIRE	
	SP751	VYH7653-001	LEAF SPRING	

XT-TD5/XT-TD55R

Electrical Parts List (VMW1430)

△	Item	Parts Number	Description	Area
		I. G. S		
	IC601	AN8806SB	I. C (MONO-ANALOG)	
	IC641	BA6897FPW	I. C (MONO-ANALOG)	
	IC651	MN35510	I. C (DIGI-MOS)	
	IC681	MN150837J8R2	I. C (M)	
	IC691	LB1641	I. C (DIGI-OTHER)	
	IC692	LB1641	I. C (DIGI-OTHER)	
		DIODES		
	D670	MA152WA-TX	DIODE	
	D671	MA152WA-TX	DIODE	
		TRANSISTORS		
	Q601	2SA1037K (R)	SI. TRANSISTOR	
	Q631	2SA952 (L. K)	SI. TRANSISTOR	
		CAPACITORS		
	C602	NCS21HJ-5R0	5PF 50V CER. CAP.	
	C604	QEKFOJM-107Z	100MF 6.3V AL E. CAP.	
	C605	QEKF1CM-106Z	10MF 16V E. CAP.	
	C607	NCB21HK-822AY	8200PF 50V CER. CAP.	
	C608	QEKF1HM-105ZN	1MF 50V E. CAP.	
	C609	NCS21HJ-101AY	100PF 50V CER. CAP.	
	C610	NCB21HK-273AY	0.027MF 50V CER. CAP.	
	C611	NCB21HK-472AY	4700PF 50V CER. CAP.	
	C612	NCB21HK-103AY	0.01MF 50V CER. CAP.	
	C613	NCS21HJ-331AY	330PF 50V CER. CAP.	
	C614	NCB21EK-104AYU	0.1MF 25V C CAP.	
	C615	NCB21HK-223AY	0.022MF 50V CER. CAP.	
	C616	NCB21HK-223AY	0.022MF 50V CER. CAP.	
	C617	NCB21HK-223AY	0.022MF 50V CER. CAP.	
	C618	NCB21HK-223AY	0.022MF 50V CER. CAP.	
	C619	NCS21HJ-271AY	270PF 50V CER. CAP.	
	C620	NCS21HJ-151AY	150PF 50V CER. CAP.	
	C621	NCB21HK-102AY	1000PF 50V CER. CAP.	
	C622	NCB21HK-223AY	0.022MF 50V CER. CAP.	
	C623	NCB21EK-104AYU	0.1MF 25V C CAP.	
	C628	NCB21HK-473AY	0.047MF 50V CER. CAP.	
	C629	QEKFOJM-107Z	100MF 6.3V AL E. CAP.	
	C631	QEKF1AM-107ZM	100MF 10V E. CAP.	
	C632	NCB21HK-473AY	0.047MF 50V CER. CAP.	
	C633	NCB21HK-222AY	2200PF 50V CER. CAP.	
	C634	NCB21HK-222AY	2200PF 50V CER. CAP.	
	C651	NCS21HJ-120AY	12PF 50V CARBON RES.	
	C652	NCS21HJ-150AY	15PF 50V CER. CAP.	
	C653	NCB21HK-223AY	0.022MF 50V CER. CAP.	
	C654	NCS21HJ-6R0AY	6PF 50V CER. CAP.	
	C655	NCB21HK-473AY	0.047MF 50V CER. CAP.	
	C657	NCB21HK-223AY	0.022MF 50V CER. CAP.	
	C658	QEKFOJM-107Z	100MF 6.3V AL E. CAP.	
	C659	QEKFOJM-107Z	100MF 6.3V AL E. CAP.	
	C661	NCS21HJ-471AY	470PF 50V CER. CAP.	
	C662	NCB21HK-223AY	0.022MF 50V CER. CAP.	
	C663	NCB21HK-223AY	0.022MF 50V CER. CAP.	
	C664	NCB21HK-223AY	0.022MF 50V CER. CAP.	
	C665	NCB21EK-104AYU	0.1MF 25V C CAP.	
	C666	QEKFOJM-227Z	220MF 6.3V AL E. CAP.	
	C671	NCB21HK-222AY	2200PF 50V CER. CAP.	
	C672	NCB21HK-222AY	2200PF 50V CER. CAP.	
	C673	QEKFOJM-227Z	220MF 6.3V AL E. CAP.	
	C674	NCB21HK-223AY	0.022MF 50V CER. CAP.	
	C675	NCB21EK-104AYU	0.1MF 25V C CAP.	
	C676	NCB21EK-104AYU	0.1MF 25V C CAP.	
	C681	QEKFOJM-227Z	220MF 6.3V AL E. CAP.	
	C687	NCB21EK-104AYU	0.1MF 25V C CAP.	
	C688	NCB21EK-104AYU	0.1MF 25V C CAP.	
	C691	NCB21HK-103AY	0.01MF 50V CER. CAP.	
	C692	NCB21HK-103AY	0.01MF 50V CER. CAP.	
	C693	VCP0012-105Z	1MF CER. CAP.	

△	Item	Parts Number	Description	Area
	C694	VCP0012-105Z	1MF CER. CAP.	
	C695	QEKF1CM-106Z	10MF 16V E. CAP.	
		RESISTORS		
	R601	NRSA02J-123NY	METAL GLAZE	
	R602	NRSA02J-102NY	METAL GLAZE	
	R603	NRSA02J-125NY	METAL GLAZE	
	R605	NRSA02J-274NY	METAL GLAZE	
	R606	NRSA02J-104NY	METAL GLAZE	
	R607	NRSA02J-223NY	METAL GLAZE	
	R608	NRSA02J-124NY	METAL GLAZE	
	R609	NRSA02J-393NY	METAL GLAZE	
	R610	NRSA02J-104NY	METAL GLAZE	
	R612	NRSA02J-822NY	METAL GLAZE	
	R613	NRSA02J-121NY	METAL GLAZE	
	R614	NRSA02J-100NY	METAL GLAZE	
	R615	NRSA02J-120NY	METAL GLAZE	
	R616	NRSA02J-910NY	METAL GLAZE	
	R617	NRSA02J-473NY	METAL GLAZE	
	R618	NRSA02J-473NY	METAL GLAZE	
	R619	NRSA02J-473NY	METAL GLAZE	
	R620	NRSA02J-473NY	METAL GLAZE	
	R621	NRSA02J-101NY	METAL GLAZE	
	R622	NRSA02J-101NY	METAL GLAZE	
	R623	NRSA02J-101NY	METAL GLAZE	
	R624	NRSA02J-101NY	METAL GLAZE	
	R625	NRSA02J-823NY	METAL GLAZE	
	R626	NRSA02J-823NY	METAL GLAZE	
	R631	NRSA02J-331NY	METAL GLAZE	
	R633	NRSA02J-273NY	METAL GLAZE	
	R641	NRSA02J-104NY	METAL GLAZE	
	R642	NRSA02J-682NY	METAL GLAZE	
	R643	NRSA02J-183NY	METAL GLAZE	
	R644	NRSA02J-223NY	METAL GLAZE	
	R645	NRSA02J-223NY	METAL GLAZE	
	R646	NRSA02J-182NY	METAL GLAZE	
	R647	NRSA02J-182NY	METAL GLAZE	
	R648	NRSA02J-472NY	METAL GLAZE	
	R649	NRSA02J-822NY	METAL GLAZE	
	R651	NRSA02J-471NY	METAL GLAZE	
	R652	NRSA02J-102NY	METAL GLAZE	
	R653	NRSA02J-102NY	METAL GLAZE	
	R654	NRSA02J-102NY	METAL GLAZE	
	R655	NRSA02J-471NY	METAL GLAZE	
	R656	NRSA02J-102NY	METAL GLAZE	
	R657	NRSA02J-102NY	METAL GLAZE	
	R658	NRSA02J-100NY	METAL GLAZE	
	R659	NRSA02J-471NY	METAL GLAZE	
	R661	NRSA02J-683NY	METAL GLAZE	
	R663	NRSA02J-124NY	METAL GLAZE	
	R664	NRSA02J-471NY	METAL GLAZE	
	R665	NRSA02J-102NY	METAL GLAZE	
	R666	NRSA02J-472NY	METAL GLAZE	
	R667	NRSA02J-472NY	METAL GLAZE	
	R668	NRSA02J-472NY	METAL GLAZE	
	R669	NRSA02J-472NY	METAL GLAZE	
	R670	NRSA02J-470NY	METAL GLAZE	
	R671	NRSA02J-102NY	METAL GLAZE	
	R672	NRSA02J-102NY	METAL GLAZE	
	R673	NRSA02J-100NY	METAL GLAZE	
	R674	NRSA02J-102NY	METAL GLAZE	
	R675	NRSA02J-104NY	METAL GLAZE	
	R676	NRSA02J-104NY	METAL GLAZE	
	R681	NRSA02J-223NY	METAL GLAZE	
	R682	NRSA02J-223NY	METAL GLAZE	
	R683	NRSA02J-223NY	METAL GLAZE	
	R684	NRSA02J-223NY	METAL GLAZE	

Electrical Parts List (VMW1430)

△	Item	Parts Number	Description	Area
	R685	NRSA02J-223NY	METAL GLAZE	
	R686	NRSA02J-223NY	METAL GLAZE	
	R687	NRSA02J-223NY	METAL GLAZE	
	R688	NRSA02J-102NY	METAL GLAZE	
	R691	NRSA02J-223NY	METAL GLAZE	
	R692	NRSA02J-223NY	METAL GLAZE	
	R693	NRSA02J-223NY	METAL GLAZE	
	R694	NRSA02J-223NY	METAL GLAZE	
	R695	NRSA02J-103NY	METAL GLAZE	
	R696	NRSA02J-181NY	METAL GLAZE	
		OTHERS		
		VMW1430-002X	PRINTED BOARD	
		VSH1173-001	SWITCH	
		EMV7169-006R	CONNECT TERMINAL	
	B601	NRSA02J-ORONY	METAL GLAZE RES.	
	B602	NRSA02J-ORONY	METAL GLAZE RES.	
	B603	NRSA02J-ORONY	METAL GLAZE RES.	
	B604	NRSA02J-ORONY	METAL GLAZE RES.	
	B605	NRSA02J-ORONY	METAL GLAZE RES.	
	B606	NRSA02J-ORONY	METAL GLAZE RES.	
	B607	NRSA02J-ORONY	METAL GLAZE RES.	
	B608	NRSA02J-ORONY	METAL GLAZE RES.	
	B609	NRSA02J-ORONY	METAL GLAZE RES.	
	B610	NRSA02J-ORONY	METAL GLAZE RES.	
	B611	NRSA02J-ORONY	METAL GLAZE RES.	
	B612	NRSA02J-ORONY	METAL GLAZE RES.	
	B613	NRSA02J-ORONY	METAL GLAZE RES.	
	B614	NRSA02J-ORONY	METAL GLAZE RES.	
	B615	NRSA02J-ORONY	METAL GLAZE RES.	
	B616	NRSA02J-ORONY	METAL GLAZE RES.	
	B617	NRSA02J-ORONY	METAL GLAZE RES.	
	L691	VQP0033-100Z	INDUCTOR	
	L692	VQP0033-100Z	INDUCTOR	
	S691	QSW0449-001	SWITCH	
	S692	QSW0449-001	SWITCH	
	S693	ESS1200-002	LEVER SWITCH	
	X651	VCX5016-934V	CRYSTAL	
	X681	EFO-EC4004T4	CERAMIC RESONATOR	
	Z651	VYH7237-003	I. C. COVER	
	Z681	VYH7237-001SS	I. C. COVER	
	CN601	VMC0332-023	CONNECTOR	
	CN604	VMC0040-003	CONNECT TERMINAL	
	CN605	EMV7171-111R	CONNECTOR	
	CN606	EMV7171-107R	CONNECTOR	
	PC691	SG-256	I. C (PHOTO-INTERRUPTOR)	

XT-TD5/XT-TD55R

Accessories List (CA-TD5)

Block No. **M6MM**

△	Item	Parts Number	Parts Name	Q'ty	Description	Area
	1	E30580-2589A	INSTRUCTION BOOK	1		J
		E30580-2590A	INSTRUCTION BOOK	1		C
		E30580-2591ABS	INSTRUCTION BOOK	1		BS
		E30580-2592A	INSTRUCTION BOOK	1		EF G
		E30580-2593A	INSTRUCTION BOOK	1		EN
		E30580-2594A	INSTRUCTION BOOK	1		VX
		E30580-2595A	INSTRUCTION BOOK	1		U UB US UT
		E30580-2596A	INSTRUCTION BOOK	1		UP
	2	E309758-003	POLY BAG	1		Except UP
		E409559-001	POLY BAG	1		UP
	3	BT-51006-1	REGISTER CARD	1		J
	4	BT-20044G	SAFETY SHEET	1		J
	5	BT-52002-1	WARRANTY CARD	1		C
		BT-56004-5	WARRANTY CARD	1		UP
		BT-20134	WARRANTY CARD	1		G
		BT-54003-1	WARRANTY CARD	1		BS
	6	BT-20071B	SERVICE NETWORK	1		C
	7	BT-20066A	DISTRIBUTOR LIST	1		BS
	8	E43486-340A	SAFETY SHEET	1		BS
	9	ENZ2203-001	ADAPTOR PLUG	1		U
		ENZ2203-001	ADAPTOR PLUG	1		UT
△	10	ENZ2202-001	SIEMENS PLUG	1		US
	11	EWP503-001	ANTENNA WIRE	1		BS EF EN G VX
	12	EWP201-011	ANTENNA WIRE	1		C J U UB UP U SUT
	13	EQB4001-015	LOOP ANTENNA	1		
	14	RM-SETD5EU	WIRE-LESS REMOTE CONTROL	1		BS EF EN G VX
		RM-SETD5U	WIRE-LESS REMOTE CONTROL	1		C J U UB UP US UT
	15	R6SPTT-2ST	DRY CELL	1		
	16	EWPZ01-005	CONNECTOR CORD ASSY	1		C J U UB UP US UT
	17	EWPZ01-028	EARTH WIRE	1		BS EF EN G VX

Accessories List (CA-TD55R)

* Please see the parts list of CA-TD5 for parts which are not described.

△	Item	Parts Number	Parts Name	Q'ty	Description	Area
	5	BT-54008-1	WARRANTY CARD	1		
	14	RM-SETD55RU	WIRE-LESS REMOTE CONTROL	1		

Packing Materials and Part Numbers

Block No. 

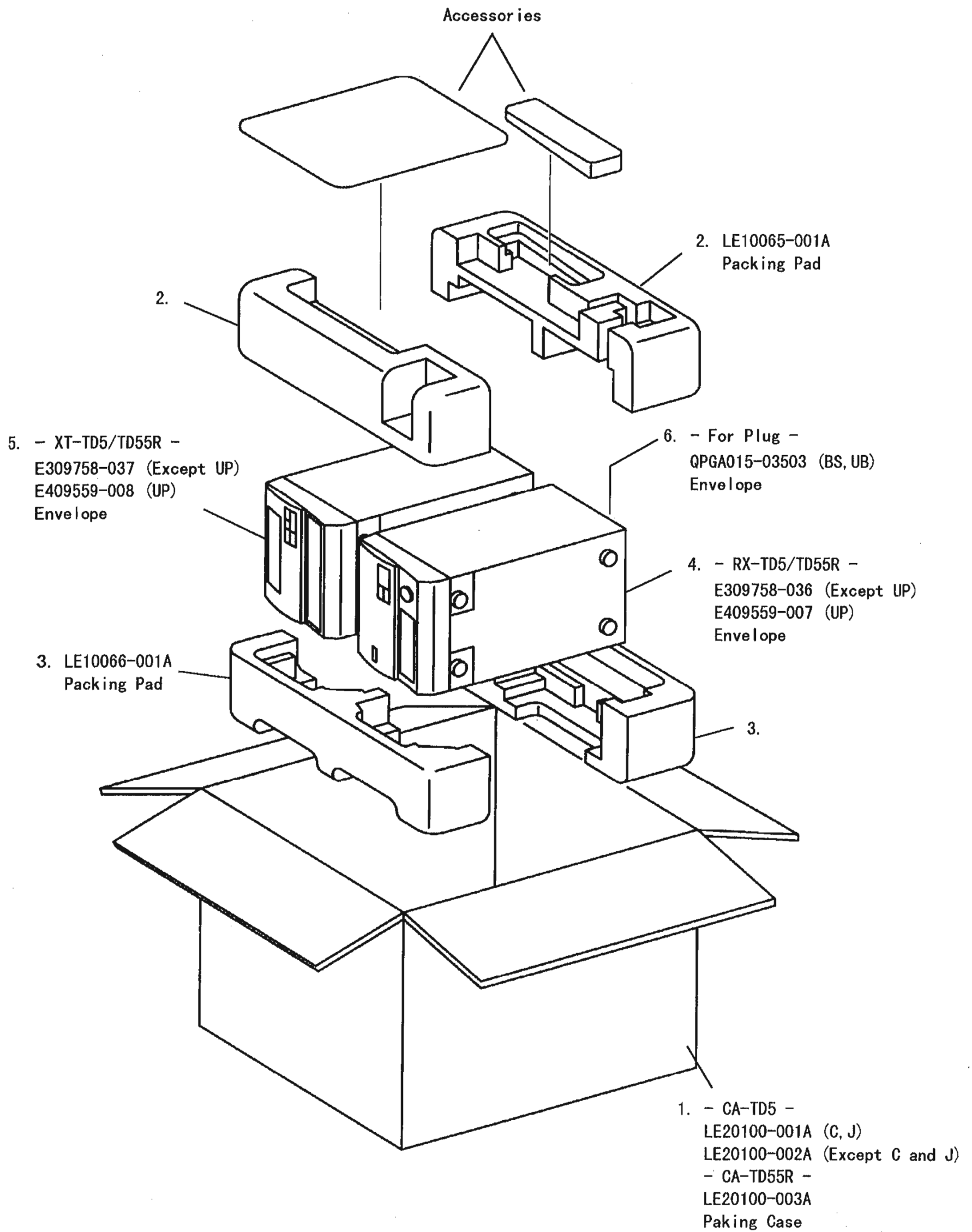

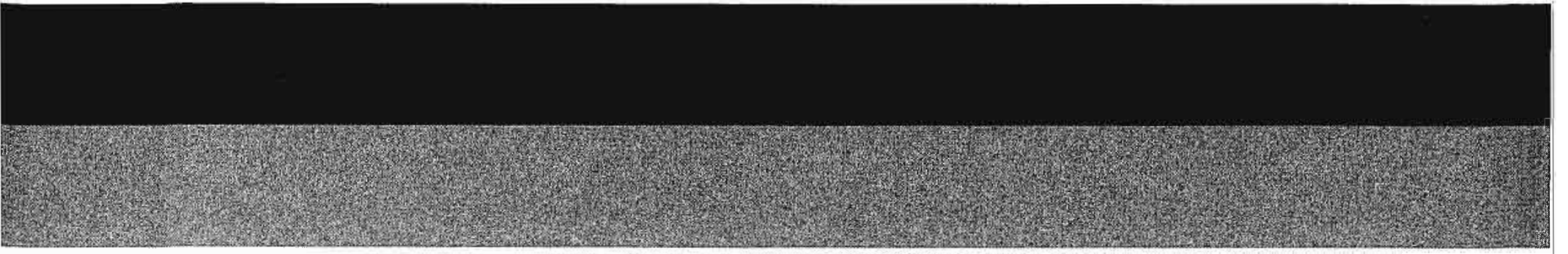

JVC

VICTOR COMPANY OF JAPAN, LIMITED
AUDIO DIVISION, 10-1, Chome, Ohwatari-machi, maebashi-city, Japan