

JVC

SERVICE MANUAL

COMPACT COMPONENT SYSTEM

MODEL NO. **DX-MX70BK/CA-MX70BK**
(UNIT NO. FX-MX70BK)

〒103東京都中央区日本橋本町4-8-11
日本ビクター株式会社
サービス部 部品管理課



- * For instruction manual, please refer to the CA-MX70BK (S.M.NO.20243) or DX-MX70BK (S.M.NO.20249).
- * AX-MX70BK is needed (for power supply etc.) when servicing.

Contents

Safety Precaution	1-2	FM / AM Tuner Alignment	
Specifications	1-3	Procedures	1-10
Description of Major LSIs	1-4	Clock Generator Frequency	
Internal Connection for		Adjustment	1-11
the FL Display Tube	1-8	Schematic Diagrams	Insertion
Disassembly Procedures	1-9	Block Diagram	Insertion
Connection Diagram	1-9	Printed Circuit Board	Insertion
		Parts List	Insertion

Safety Precautions

1. The design of this product contains special hardware and many circuits and components specially for safety purposes. For continued protection, no changes should be made to the original design unless authorized in writing by the manufacturer. Replacement parts must be identical to those used in the original circuits. Services should be performed by qualified personnel only.
2. Alterations of the design or circuitry of the product should not be made. Any design alterations of the product should not be made. Any design alterations or additions will void the manufacturer's warranty and will further relieve the manufacture of responsibility for personal injury or property damage resulting therefrom.
3. Many electrical and mechanical parts in the products have special safety-related characteristics. These characteristics are often not evident from visual inspection nor can the protection afforded by them necessarily be obtained by using replacement components rated for higher voltage, wattage, etc. Replacement parts which have these special safety characteristics are identified in the Parts List of Service Manual. Electrical components having such features are identified by shading on the schematics and by (Δ) on the Parts List in the Service Manual. The use of a substitute replacement which does not have the same safety characteristics as the recommended replacement parts shown in the Parts List of Service Manual may create shock, fire, or other hazards.
4. The leads in the products are routed and dressed with ties, clamps, tubings, barriers and the like to be separated from live parts, high temperature parts, moving parts and/or sharp edges for the prevention of electric shock and fire hazard. When service is required, the original lead routing and dress should be observed, and it should be confirmed that they have been returned to normal, after re-assembling.
5. Leakage current check (Electrical shock hazard testing)
After re-assembling the product, always perform an isolation check on the exposed metal parts of the product (antenna terminals, knobs, metal cabinet, screw heads, headphone jack, control shafts, etc.) to be sure the product is safe to operate without danger of electrical shock.
Do not use a line isolation transformer during this check.

- Plug the AC line cord directly into the AC outlet. Using a "Leakage Current Tester", measure the leakage current from each exposed metal parts of the cabinet, particularly any exposed metal part having a return path to the chassis, to a known good earth ground. Any leakage current must not exceed 0.5mA AC (r.m.s.).

- Alternate check method
Plug the AC line cord directly into the AC outlet. Use an AC voltmeter having, 1,000 ohms per volt or more sensitivity in the following manner. Connect a 1,500 Ω 10 W resistor paralleled by a 0.15 μ F AC-type capacitor between an exposed metal part and a known good earth ground.

Measure the AC voltage across the resistor with the AC voltmeter.

Move the resistor connection to each exposed metal part, particularly any exposed metal part having a return path to the chassis, and measure the AC voltage across the resistor.

Now, reverse the plug in the AC outlet and repeat each measurement. Any voltage measured must not exceed 0.75 V AC (r.m.s.). This corresponds to 0.5 mA AC (r.m.s.).

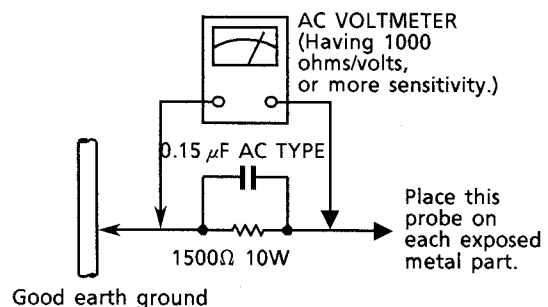

Warning

1. This equipment has been designed and manufactured to meet international safety standards.
2. It is the legal responsibility of the repairer to ensure that these safety standards are maintained.
3. Repairs must be made in accordance with the relevant safety standards.
4. It is essential that safety critical components are replaced by approved parts.
5. If mains voltage selector is provided, check setting for local voltage.

Specifications

FM TUNER SECTION

Tuning range : 87.5 MHz — 108.0 MHz
 Usable sensitivity : 0.95 μ V / 75 ohms(10.8 dBf)
 Signal-to-noise ratio : MONO (at 85dBf) 80 dB / 72dB
 (IHF-A Weighted / DIN) STEREO (at 85dBf) 73 dB / 64dB

AM TUNER SECTION

MW

Tuning range

Area	Channel space	
	9kHz	10kHz
U.S.A. Canada	—	530kHz~1710kHz
Continental Europe, U.K.	522kHz~1629kHz	—
Italy	522kHz~1629kHz	—
Australia	522kHz~1629kHz	—
Other Area	531kHz~1602kHz	530kHz~1600kHz

LW

Tuning range

Area	Channel Space (1kHz)
U.S.A. Canada	—
Continental Europe, U.K.	144kHz~353kHz
Italy	144kHz~290kHz
Australia	—
Other Area	—

GENERAL

Dimensions : 10-7/8" × 2-11/16" × 10-7/8" inches
 (W×H×D) (275 × 68 × 275 mm)
 Weight : 3.6 lbs. (1.6 kg)

Design and specifications subject to change without notice.

Description of Major LSIs

■ H614089SC35(IC201) : System Controller

1. Terminal Layout

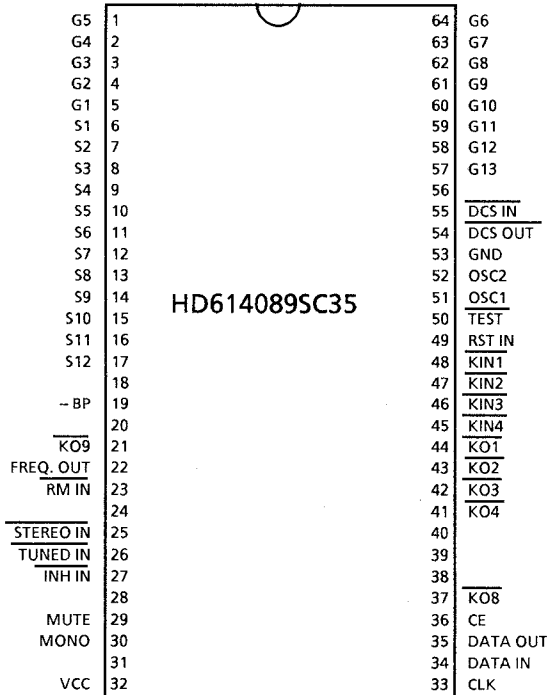

2. Key Matrix

	KEY OUT 1 (pin44)	KEY OUT2 (pin43)	KEY OUT3 (pin42)	KEY OUT4 (pin41)
KEY IN 1 (pin48)	TP203 (POWER)	WAKE-UP /SLEEP	UP	FM
KEY IN 2 (pin47)	TIMER1	CLOCK ADJ	DOWN	AM
KEY IN 3 (pin46)	TIMER2	CANCEL	PRESET UP	FM MODE/MUTE
KEY IN 4 (pin45)	DAILY	MEMORY	PRESET DOWN	—

3. Pin Functions

Pin NO.	symbol	I/O	Function and Operations	Pin NO.	symbol	I/O	Function and Operations
1	G5	O	FL grid control output	33	CLK	O	Clock output for data transmit
2	G4	O	“	34	DAATA IN	I	Data input
3	G3	O	“	35	DATA OUT	O	Data output
4	G2	O	“	36	CE	O	Chip enable
5	G1	O	“	37	KO8	O	Version setting signal
6	S1	O	FL segment control output	38	—	--	Non connection
7	S2	O	“	39	—	--	“
8	S3	O	“	40	—	--	“
9	S4	O	“	41	KO4	O	Key matrix output
10	S5	O	“	42	KO3	O	“
11	S6	O	“	43	KO2	O	“
12	S7	O	“	44	KO1	O	“
13	S8	O	“	45	KIN4	I	Key matrix input
14	S9	O	“	46	KIN3	I	“
15	S10	O	“	47	KIN2	I	“
16	S11	O	“	48	KIN1	I	“
17	S12	O	“	49	RST IN	I	Reset signal input
18	—	--	Non connection	50	TEST	--	TEST terminal
19	--BP	I	Power supply for FL Display	51	OSC1	I	Clock oscillation input
20	—	--	Non connection	52	OSC2	O	Clock oscillation output
21	KO9	O	Key matrix output	53	GND	--	Ground
22	FREQ. OUT	O	Clock frequency output	54	DCS OUT	O	Compulink signal output
23	RM IN	I	Remote control signal input	55	DCS IN	I	Compulink signal input
24	—	--	Non connection	56	—	--	Non connection
25	STEREO IN	I	Input for indication of “STEREO”	57	G13	O	FL grid control output
26	TUNED IN	I	Input for indication of “TUNED”	58	G12	O	“
27	INH IN	I	Inhibit signal input	59	G11	O	“
28	—	--	Non connection	60	G10	O	“
29	MUTE	O	Muting signal output	61	G9	O	“
30	MONO	--	Non connection	62	G8	O	“
31	—	--	“	63	G7	O	“
32	VCC	I	Power supply	64	G6	O	“

■ LC7218 (IC102) : PLL Synthesizer

1. The main function descriptions

- (1) It makes the local oscillation frequency by the control data from IC201.
- (2) Decode the control signal and transmit the signal for receiving conditions.
- (3) For the best tuning, count the internal-frequency and transmit the data to IC201.

2. Terminal Layout

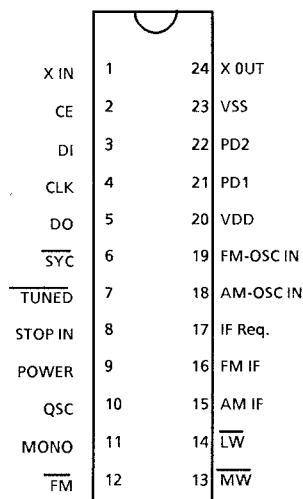

3. Block Diagram

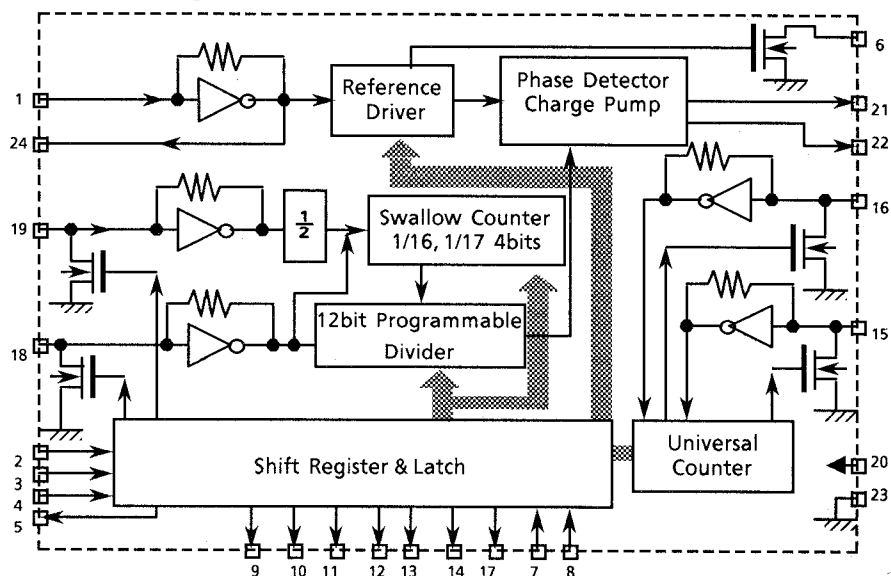

4. Pin Functions

Pin No.	Symbol	I/O	Functions and Operations
1,24	X in, X out	I/O	Crystal oscillator (7.2MHz).
2	CE	I	Fix the chip enable to "H" when inputting (DI) and outputting (DO) the serial data.
3	DI	I	Receive the control data from the controller (IC201).
4	CLK	I	This clock is used to synchronize data when transmitting the data of DI and DO.
5	DO	O	Transmit the data from LC7218 to the controller which is synchronized with CL.
6	SYC	--	Not used.
7	TUNED	I	Receive the tuned signal from IC104 (LA1266A).
8	STOP IN	I	Not used.
9	POWER	O	Not used.
10	QSC	O	ON mode with "H" and OFF mode with "L". (NOT USED)
11	MONO	O	It is "H" on FM-monaural, "L" on FM-Stereo.
12	FM	O	It is "H" on FM mode.
13	MW	O	It is "H" on MW mode.
14	LW	O	It is "H" on LW mode.
15	AM-IF	I	Universal counter input for AM-IF from IC104 (LA1266A).
16	FM-IF	I	Universal counter input for FM-IF from IC104 (LA1266A).
17	IF Req.	O	Output the "IF-signal request" to IC104 when the pin-7 (TUNED) go to "H".
18	AM OSC IN	I	Input the local oscillator signal of AM.
19	FM OSC IN	I	Input the local oscillator signal of FM.
20	VDD	--	This is a terminal of power supply.
21	PD1	O	PLL charge pump output: When the local oscillator signal frequency is higher than the reference frequency high level signals will output. When it is lower than the reference frequency, low level signals will output. When it is same as reference frequency signals, it will be floating.
22	PD2	O	Not used.
23	VSS	--	Power supply.

■ LA1266A (IC104) : FM AM IF AMP & detector

1. The main function descriptions

- (1) Amplify and detect of FM IF frequencies.
- (2) It has local oscillator and mixer for AM, and amplify the AM-IF signal.

2. Terminal Layout

3. Block Diagram

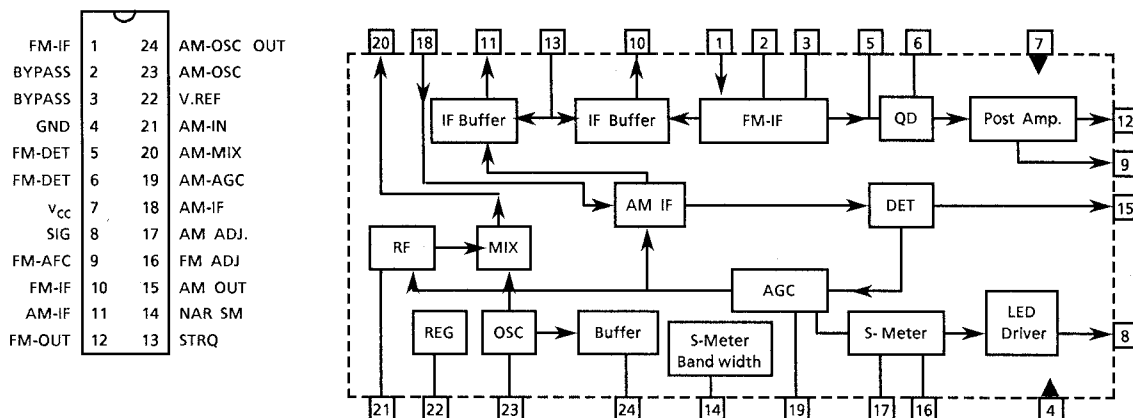

FM-IF	1	24	AM-OSC OUT
BYPASS	2	23	AM-OSC
BYPASS	3	22	V.REF
GND	4	21	AM-IN
FM-DET	5	20	AM-MIX
FM-DET	6	19	AM-AGC
V _{CC}	7	18	AM-IF
SIG	8	17	AM ADJ.
FM-AFC	9	16	FM ADJ
FM-IF	10	15	AM OUT
AM-IF	11	14	NAR SM
FM-OUT	12	13	STRQ

4. Pin Functions

Pin No.	Symbol	I/O	Functions and Operations
1	FM IF	I	This is an input terminal of FM IF Signal.
2,3	BYPASS	--	Bypass of FM IF Amp.
4	GND	--	This is the device ground terminal.
5,6	FM DET	--	FM detect transformer.
7	V _{CC}	--	This is the power supply terminal.
8	TUNED	O	When the set is tuning, this terminal become "L".
9	FM AFC	O	This is an output terminal of voltage for FM-AFC.
10	FM IF OUT	O	When the signal of IF REQ of IC102(LC7218) applied to pin17, the signal of FM IF does output.
11	AM IF OUT	O	When the signal of IF REQ of IC102(LC7218) applied to pin17, the signal of AM IF does output.
12	FM OUT	O	FM detection output.
13	STRQ	I	The IF-signals come out from pin10 (FM-IF) or pin11 (AM-IF) while this terminal going to "High".
14	NAR SM	--	Control the Band-width of signal meter.
15	AM OUT	O	AM detection output.
16	FM ADJ	--	For adjust the stop level (or mute level) of FM.
17	AM ADJ	--	For adjust the stop level (or mute level) of AM.
18	AM-IF	I	Input of AM IF Signal.
19	AM-AGC	I	This is an AGC voltage Input terminal for AM.
20	AM-MIX	O	This is an output terminal for AM mixer.
21	AM-IN	I	This is an input terminal for AM RF Signal.
22	V.REF	--	Register value between pin9 and pin22 desides the frequency width of the input signal.
23	AM-OSC	--	This is a terminal of AM Local oscillation circuit.
24	AM-OSC OUT	O	AM Local Oscillation Signal output.

■ LA3401 (IC105) : FM MPX Decoder

1. The main function descriptions

- (1) Decord the FM Multiplex Signal (Stereo signal).
- (2) When receiving FM Stereo Signal, it outputs the signal for indicator.
- (3) AM /FM Audio Amplifier.

2. Terminal Layout

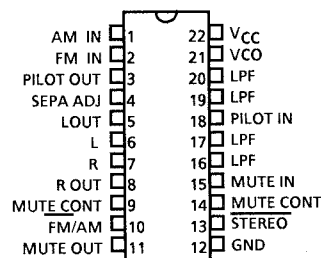

3. Block Diagram

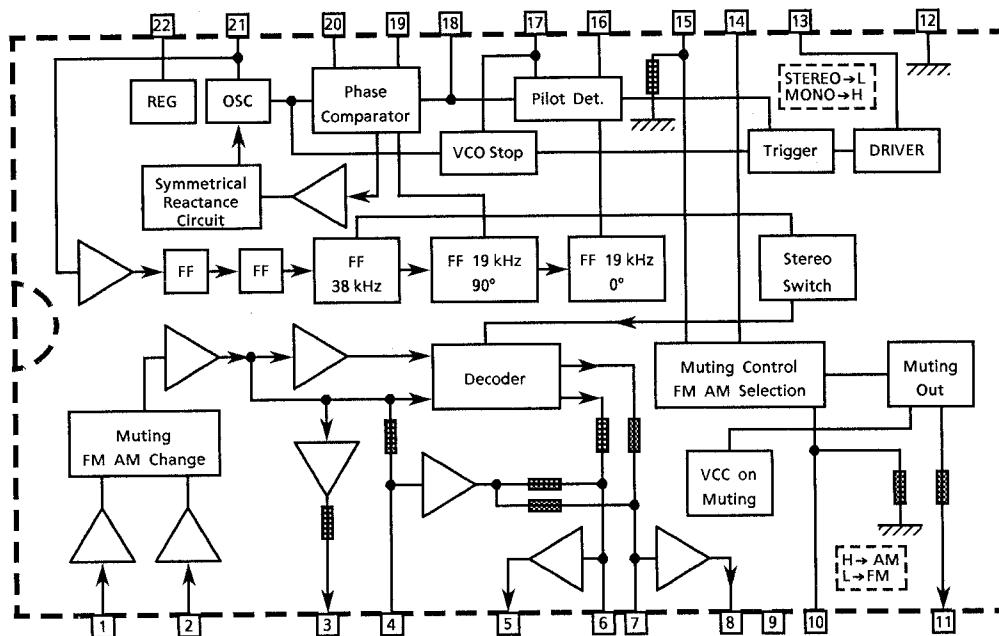

4. Pin Functions

Pin No.	Symbol	I/O	Functions and Operations
1	AM IN	I	This is an input terminal for AM detection signal.
2	FM IN	I	This is an input terminal for FM detection signal.
3	PILOT OUT	O	Output of MPX pilot signal (Connect to Pin18).
4	SEPA. ADJ.	--	Separation adjustment.
5	L. OUT	O	Left channel signal output.
6	L	O	Input terminal of the Left channel Post AMP.
7	R	O	Input terminal of the right channel Post AMP.
8	R OUT	O	Right channel signal output
9	MUTE CONT	--	The mute time is controlled by the connected capacitor when turning the power switch on.
10	FM /AM	I	Change over the FM /AM input. "H" : AM, "L" : FM
11	MUTE OUT	---	Not use
12	GND	--	Ground terminal.
13	STEREO	O	Stereo indicator output. Stereo : "L", Mono : "H"
14	MUTE CONT	--	The mute time is controlled by the connected capacitor when changing over the FM /AM .
15	MUTE IN	I	Mute signal input. "H" : Mute on, "L" : Mute off.
16	LPF	--	Low pass filter of pilot detector.
17	LPF	--	While this terminal goes to "H", the VCO stop.
18	PILOT IN	I	PLL input.
19	LPF	--	Low-pass filter of PLL.
20	LPF	--	Low-pass filter of PLL.
21	VCO	I	Voltage controlled oscillator terminal.
22	V _{cc}	--	Power supply.

Internal Connections for the FL Display Tube

■ ELU0001-101:(FL201)

1. Grid Assignment

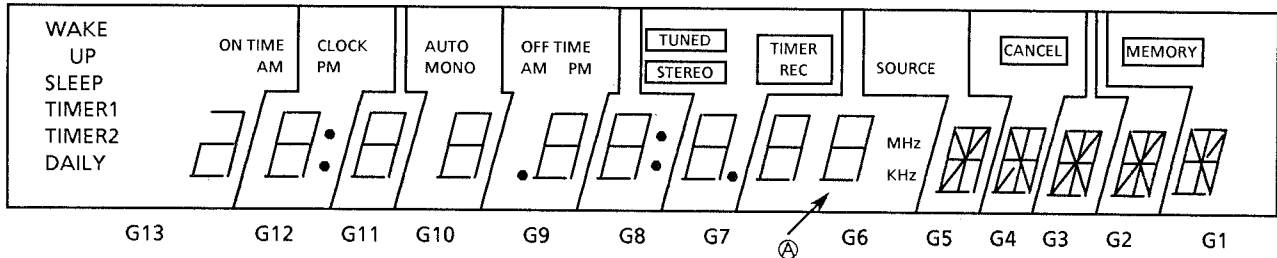

2. Pin Connections

PIN NO.	1	2	3	4	5	6	7	8	9	10	11	12	13	14	15	16	17	18	19	20	21	22	23
CONNECTION	FL1	FL1	NP	NC	G13	S1	S2	G13	S3	S4	G12	G12	S5	G11	S6	G10	S7	G9	G9	S8	S9	G8	S10
PIN NO.	24	25	26	27	28	29	30	31	32	33	34	35	36	37	38	39	40	41	42	43	44	45	46
CONNECTION	G7	S11	G6	S12	NC	NC	NC	G6	NC	G5	NC	G4	G4	NC	G3	NC	G2	NC	G1	NC	NP	F2	F2

[Note] F: Filament S: Segment G: Grid NP: No Pin NC: Non Connection

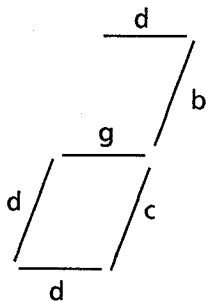

G13

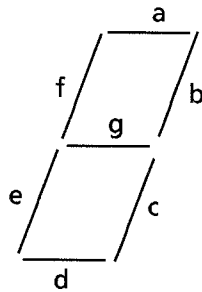

G6 ~ G12

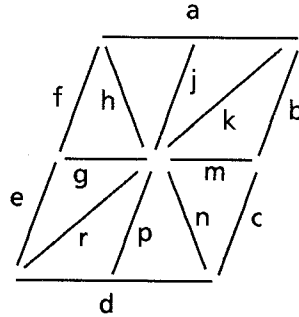

G1 ~ G5

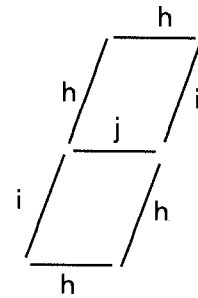

Ⓐ

3. Anode Connections

	G13	G12	G11	G10	G9	G8	G7	G6	G5	G4	G3	G2	G1
S1	d	d	d	d	d	d	d	d	d	d	d	d	d
S2	—	e	e	e	e	e	e	e	e	e	e	e	e
S3	c	c	c	c	c	c	c	c	c	c	c	c	c
S4	g	—	—	—	—	—	—	kHz	r	r	r	r	m
S5	b	•	—	—	•	•	•	MHz	k	n	n	n	n
S6	DAILY	—	—	—	AM	—	STEREO	i	j,p	j,p	j,p	j,p	j,p
S7	TIMER2	g	g	g	g	g	g	g	g,m	g,m	g,m	g,m	g
S8	TIMER1	f	f	f	f	f	f	f	f	f	f	f	f
S9	SLEEP	b	b	b	b	b	b	b	b	b	b	b	b
S10	WAKE UP	a	a	a	a	a	a	a	a	a	a	a	a
S11	AM	PM	—	MONO	PM	—	TUNED	j	h	h	h	h	h,k
S12	ON TIME	CLOCK	—	AUTO	OFFTIME	—	TIMER REC	h	SOURCE	CANCEL	k	k	MEMORY

Disassembly Procedures

■ Removing the Top Cover

1. Remove the 4 screws ⑥ fastening the rear side of the Top cover, and 2 screws ⑤ fastening both sides.
2. Remove the Top Cover.

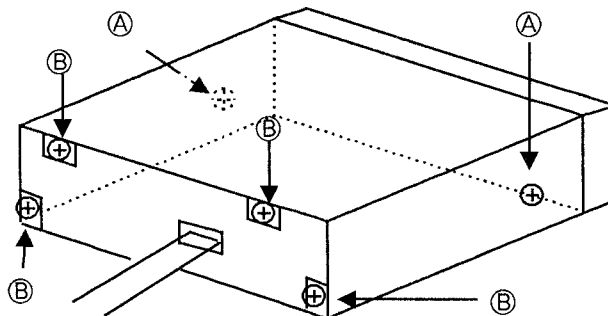

■ Removing the Front P.C.Board.

1. Remove the Top Cover.
2. Remove 4 screws ③ fastening the P.C.Board, and remove it.

■ Removing the Main P.C. Board

1. Remove the Top Cover.
2. Remove the 4 screws ④ fastening the P.C. Board.
3. Remove the screws ⑦ ⑧ and remove the P.C.Board.

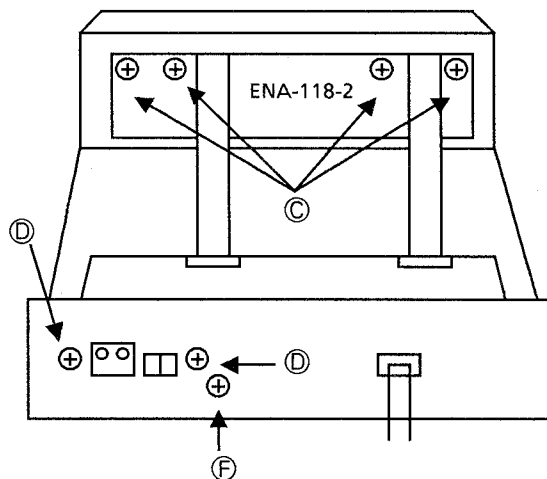
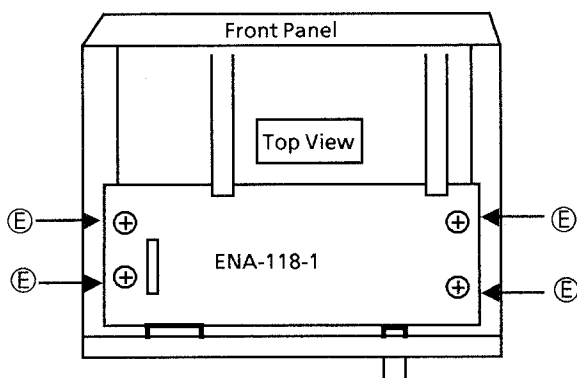

Connection Diagram

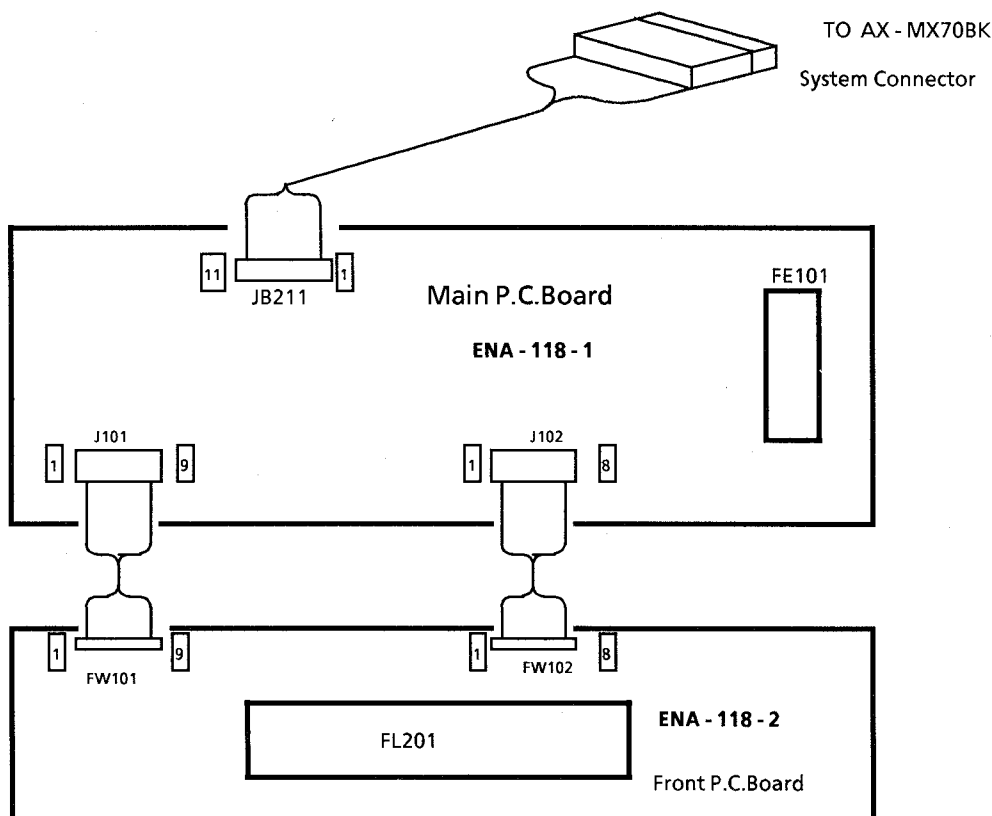

FM/AM Tuner Alignment Procedures

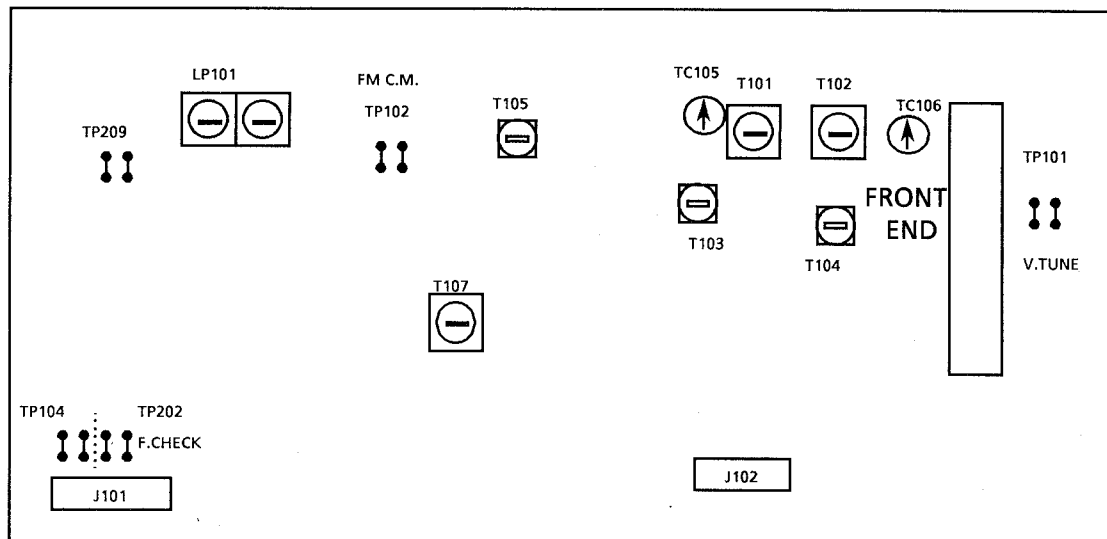

■ DISCHARGE

When discharging the backup, shortcircuit the two terminals of TP104.

1. FM section

■ FM oscillator

- (1) Set the frequency display to "108.0MHz".
- (2) Confirm that the FM inter-station noise is received.
- (3) Confirm that the voltage of test point "TP101" is $8.0V \pm 2.0V$.
- (4) Set the frequency display to "87.5MHz" and confirm the voltage of test point "TP101" is $1.6V \pm 1.0V$.

■ FM detector coil : T105

- (1) Connect a digital voltmeter to test point "TP102", and receive to "100.1MHz" signal with SSG at 70dB.
- (2) Adjust T105 so that the digital voltmeter reads $0 \pm 1.5mV$.

2. MW section

Note (): Australia, the U.K. and Continental Europe
 { }: Channel space 9kHz for universal version
 []: Channel space 10kHz for universal version
 []: America, Canada

■ MW oscillator : T103

- (1) Set the frequency display to (522kHz) {531kHz} [530kHz] [530kHz] and confirm that the voltage of test point TP101 is $(0.9V \pm 0.2V)$ { $1.0V \pm 0.2V$ } [$1.0V \pm 0.2V$] [$1.0V \pm 0.2V$].
- (2) Set the frequency display to (1629kHz) {1602kHz} [1600kHz] [1710kHz] and confirm that the voltage of test point TP101 is $(7.5V \pm 0.8V)$ { $7.2V \pm 0.7V$ } [$7.2V \pm 0.7V$] [$8.0V \pm 0.8V$].
- (3) If its voltage exceeds the allowance, adjust T103 to obtain the voltage.

■ MW antenna coil : T101

- (1) Connect a loop antenna to the "AM Loop" terminal on the rear panel.
- (2) Adjust T101 to obtain the best receiving sensitivity on 600kHz or 603kHz.

■ MW antenna trimmer : TC105

- (1) Adjust TC105 to obtain the best receiving sensitivity on 1400kHz or 1404kHz.

3. LW section (for Long Wave Version)

Note : [] for Italy

■ LW oscillator : T104

- (1) Set the frequency display to 144kHz and adjust T104 so that the voltage of TP101 becomes $0.8V \pm 0.1V$.
- (2) Set the frequency display to 353kHz [290kHz] and confirm that the voltage of test point TP101 becomes $8.0V \pm 0.9V$ [$5.7V \pm 0.6V$].

■ LW antenna coil : T102

- (1) Connect a loop antenna to the "AM Loop" terminal on the rear panel.
- (2) Adjust T102 to obtain the best receiving sensitivity on 164kHz [164kHz].

■ LW antenna trimmer : TC106

- (1) Adjust TC106 to obtain the best receiving sensitivity on 353kHz [245kHz].

※ Alternately adjust T102 and TC106 so that each sensitivity becomes maximum.

Clock Generator Frequency Adjustment

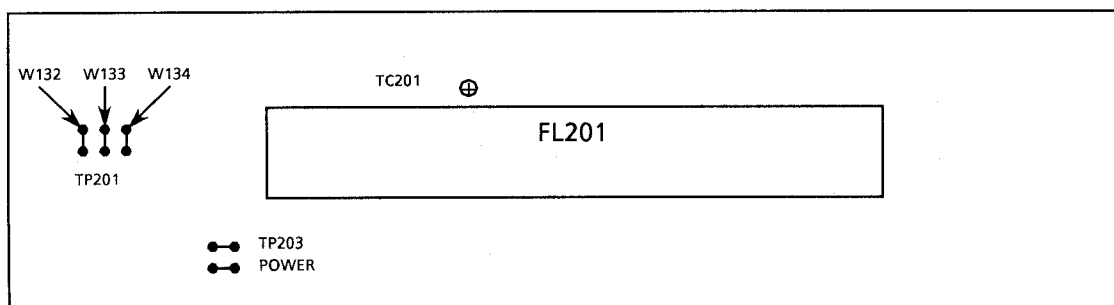

1. Switch OFF the AX-MX70BK's power source, then pull out the AC plug.
2. Shortcircuit TP201's terminals ② and ③ with the diode as shown in the accompanying diagram, then insert the AC plug into the receptacle to switch the power ON.
3. Confirm that the tuner's FL display is off, then remove the diode and connect the frequency counter to TP 202(FREQ. CHECK).
4. Adjust TC201 so that the counter becomes $34,952.5 \pm 0.15$ Hz.

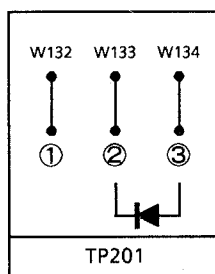

Example :
1S5133
1S5119
1S2473

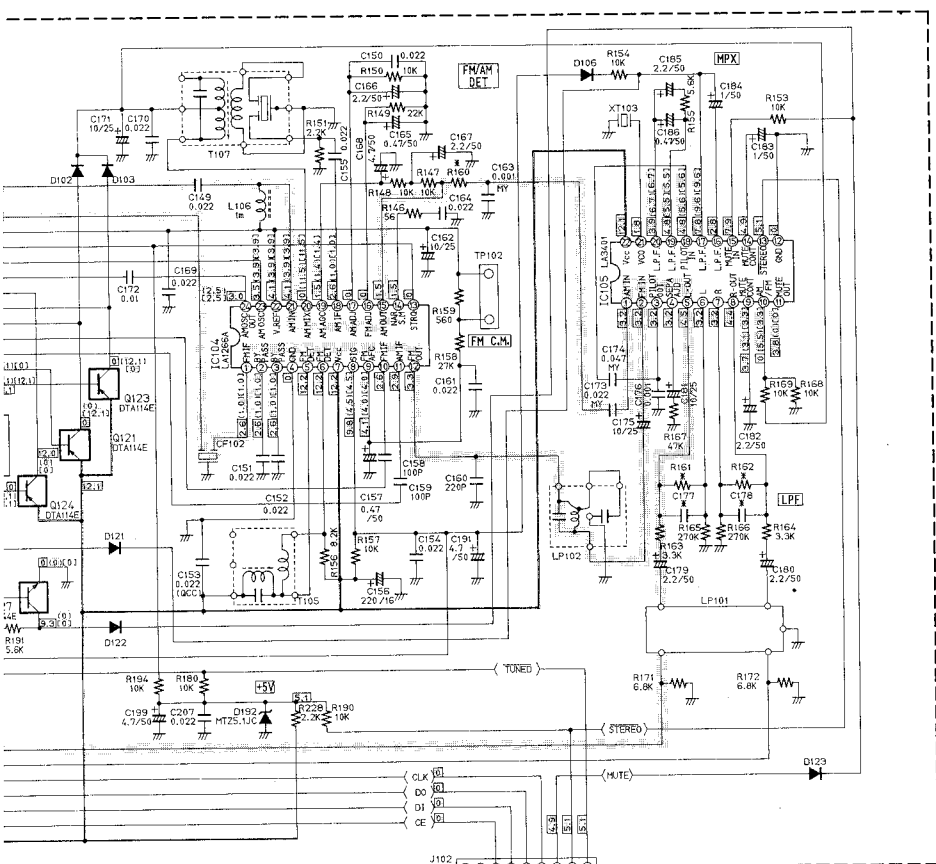

* MARK

	E.E.F	G.G.I	BS
R160	18K	18K	8.2K
R161,162	120K	120K	8.2K
C177,178	390P	390P	560P
D151	NONE	NONE	NONE
D152	NONE	NONE	NONE
D153	NONE	NONE	NONE
D154	NONE	USED(G.I)	NONE

NO MARK DIODES ARE 1SS133
 □ FM AUTO NO SIGNAL (87.5MHz)
 () MW NO SIGNAL (522KHz)
 [] LW NO SIGNAL (144KHz)

How to Use Schematic Diagrams

1. ——— indicates the +B line.
2. - - - - indicates the -B line.
3. [] indicates signal path.
4. □ indicates voltage value.
5. Parts marked with Δ and those in the shaded area are parts for safety. Be sure to use one with the specified part number.
6. This is the standard circuit diagram. The circuits and circuit constants are subject to change for improvement without notice.

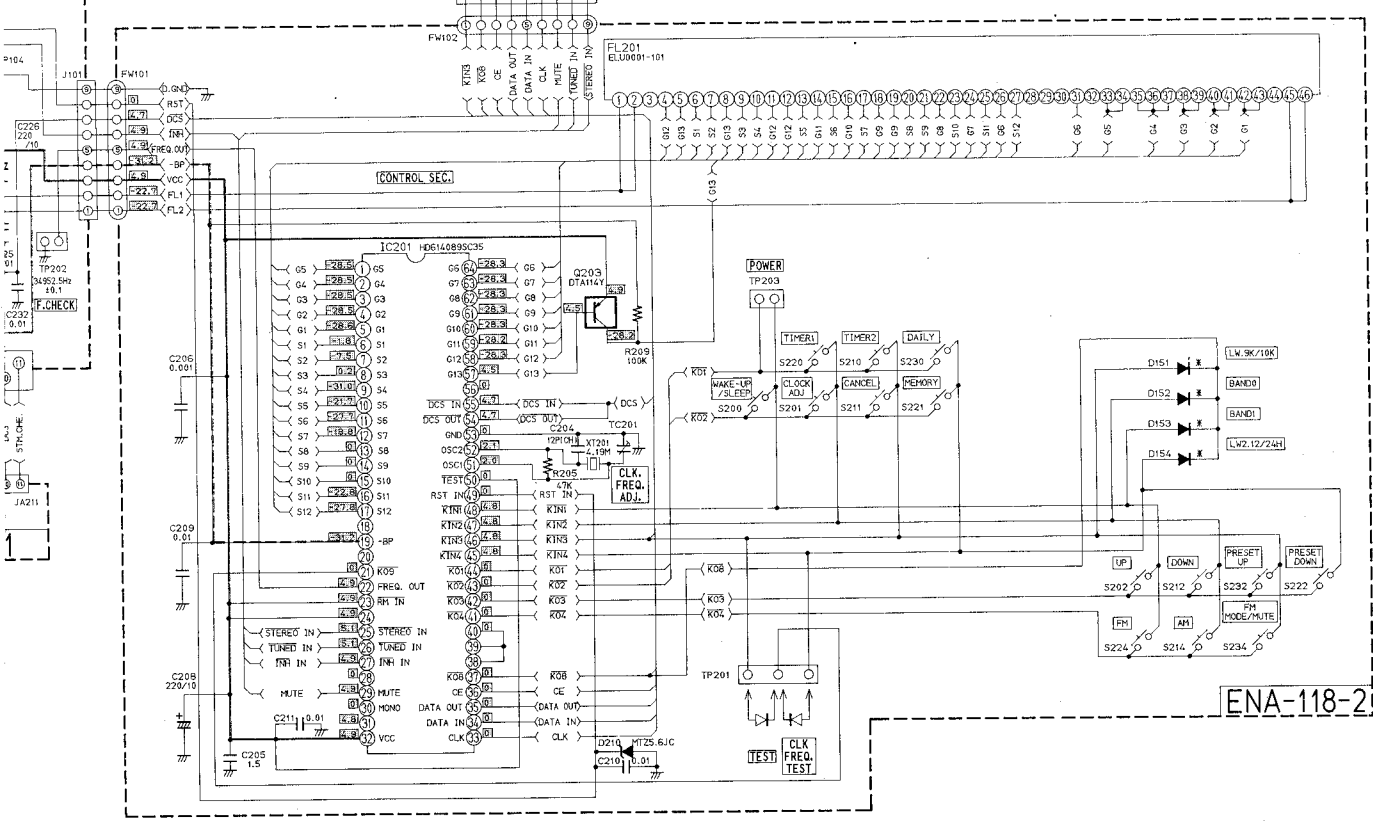

ENA-118-2

■ Tuner 2

FX-MX70BK (J,C,U,A)

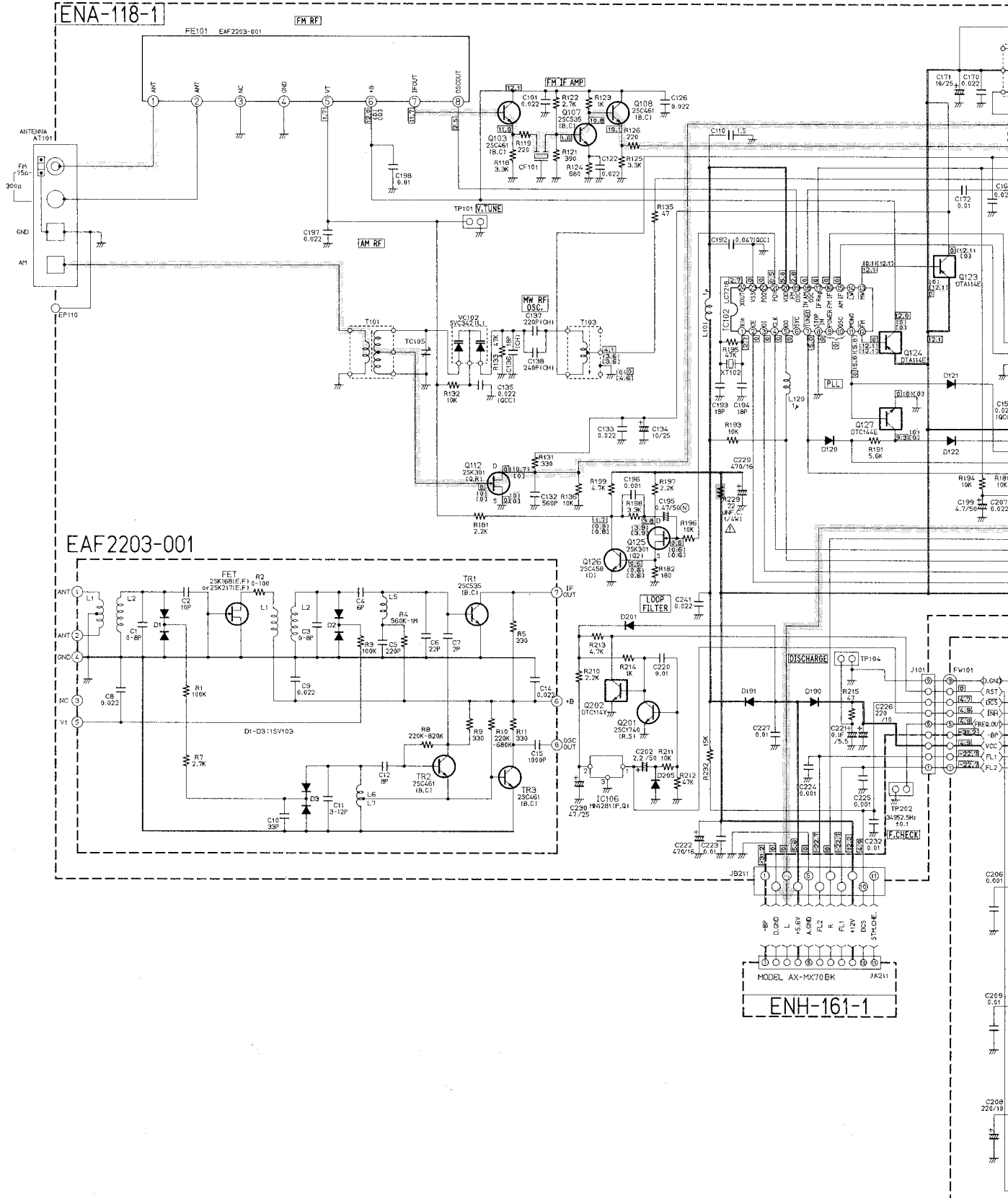

Block Diagram

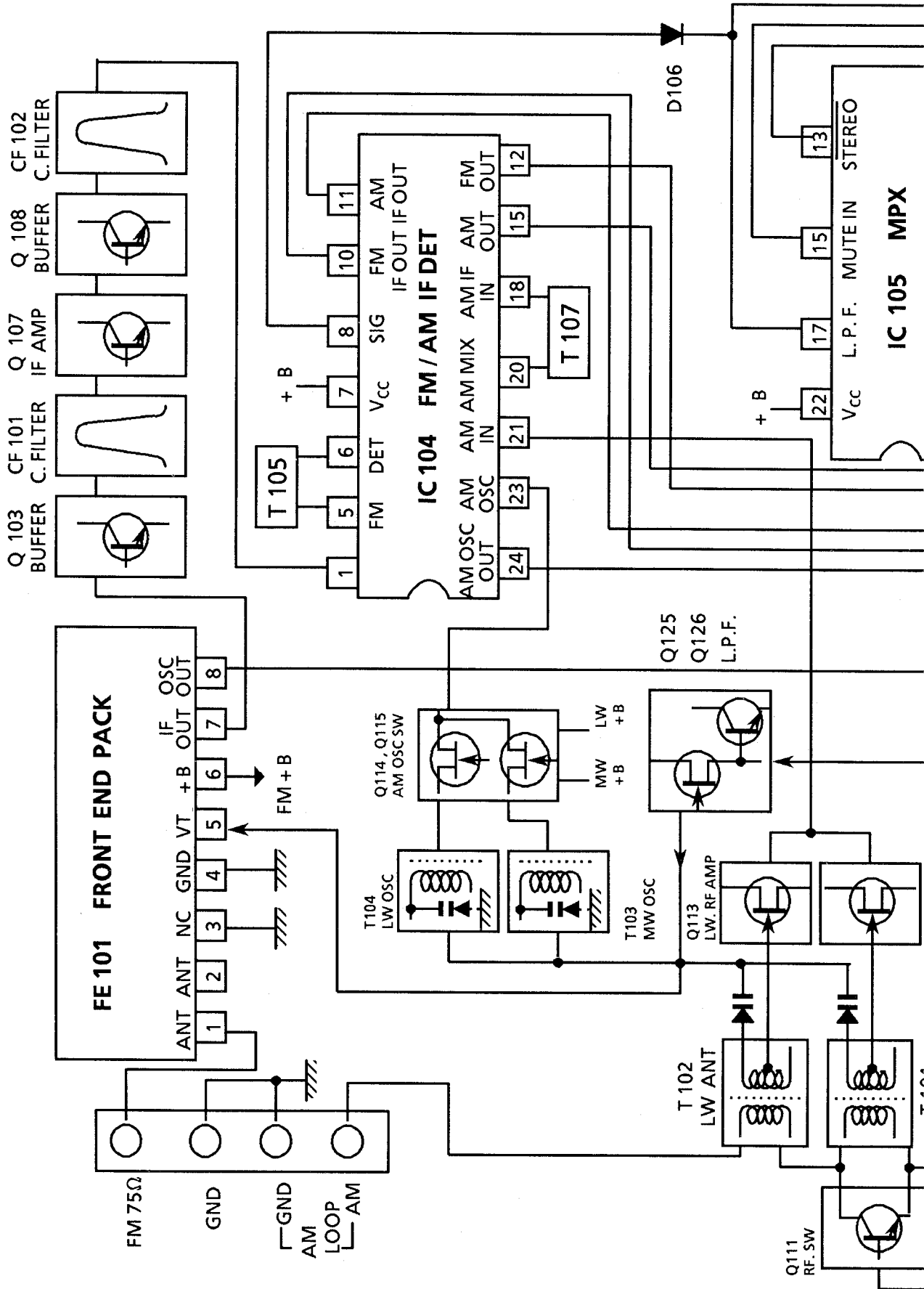

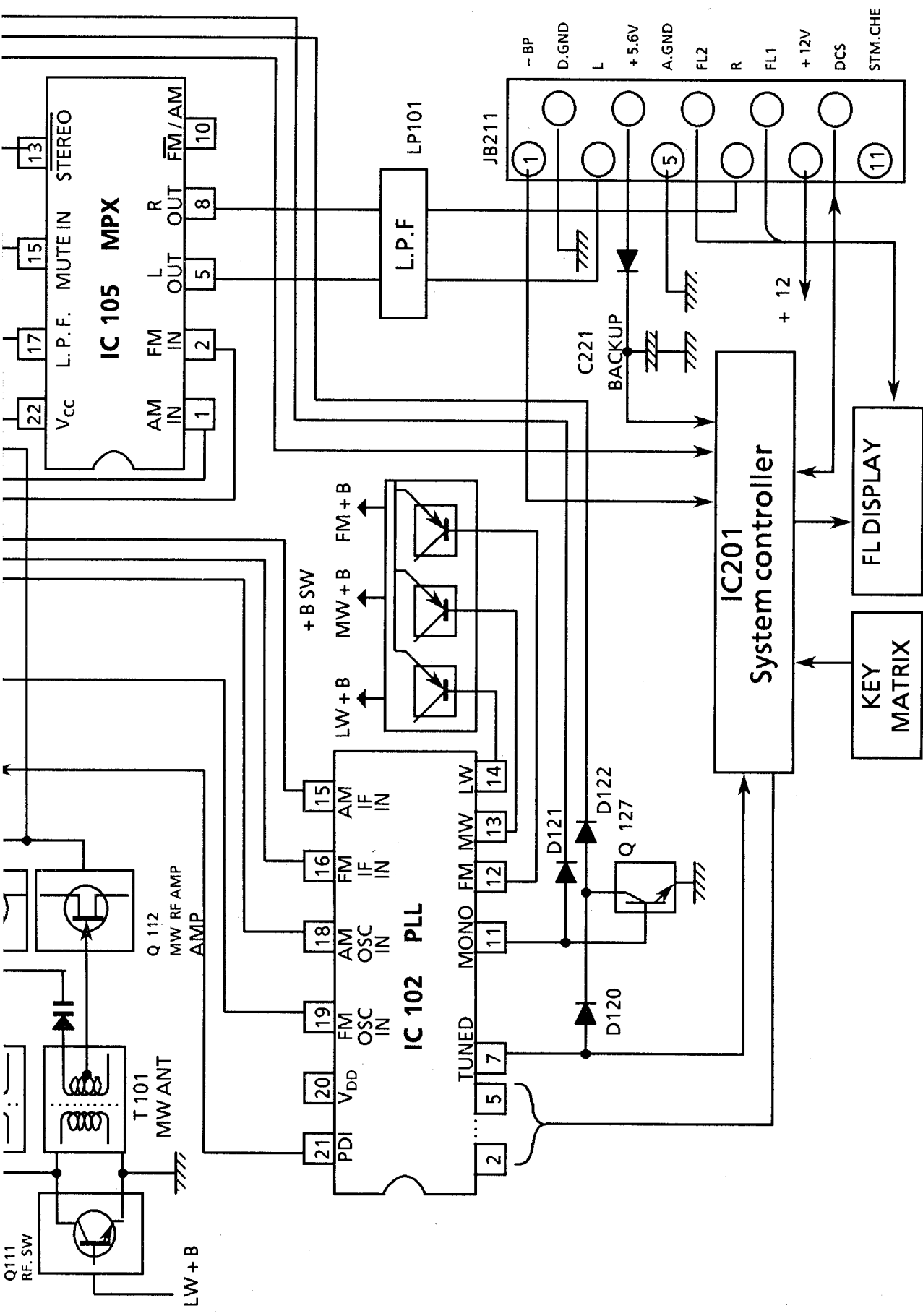

Printed Circuit Board

■ Tuner PCB (ENA118)

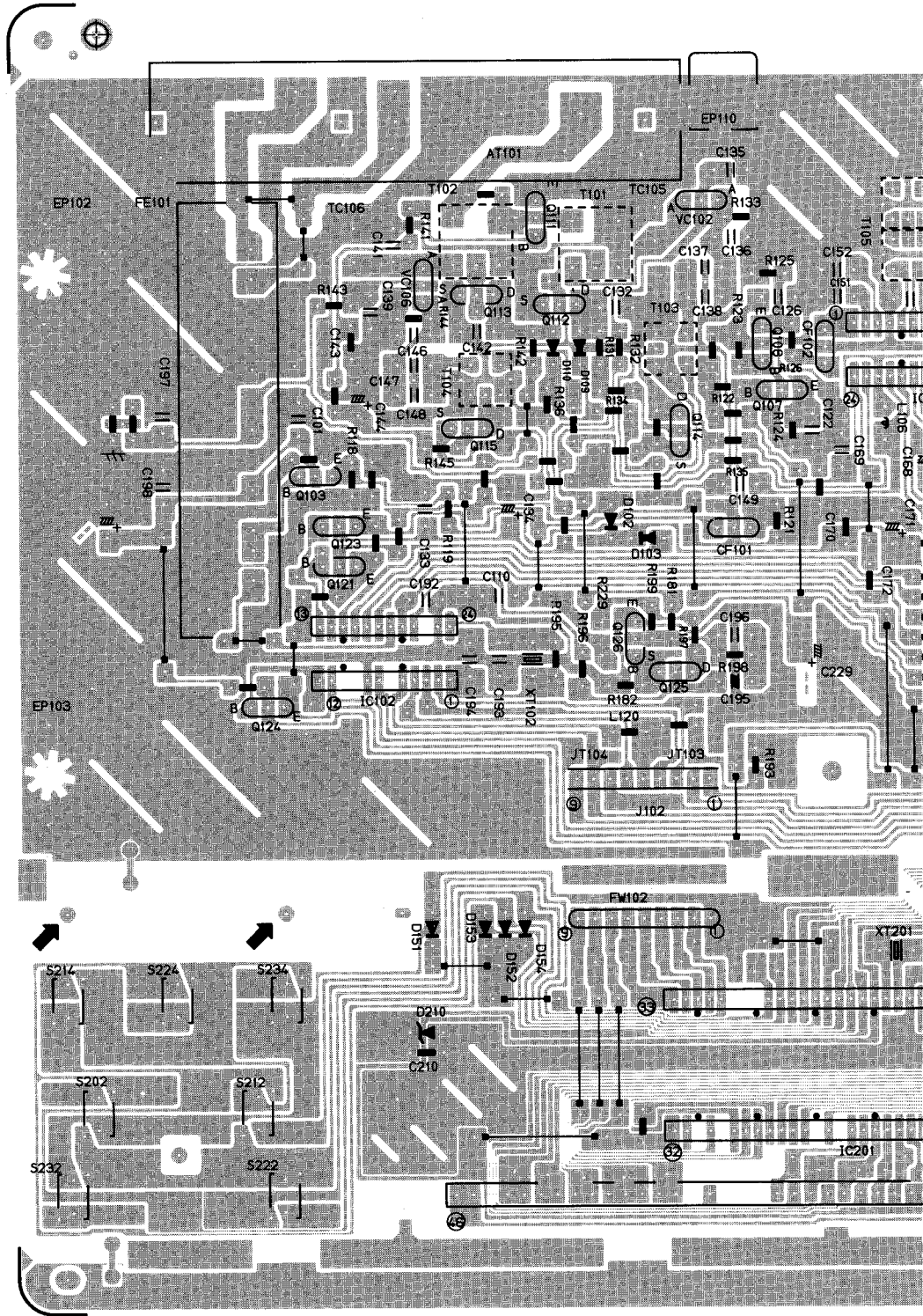

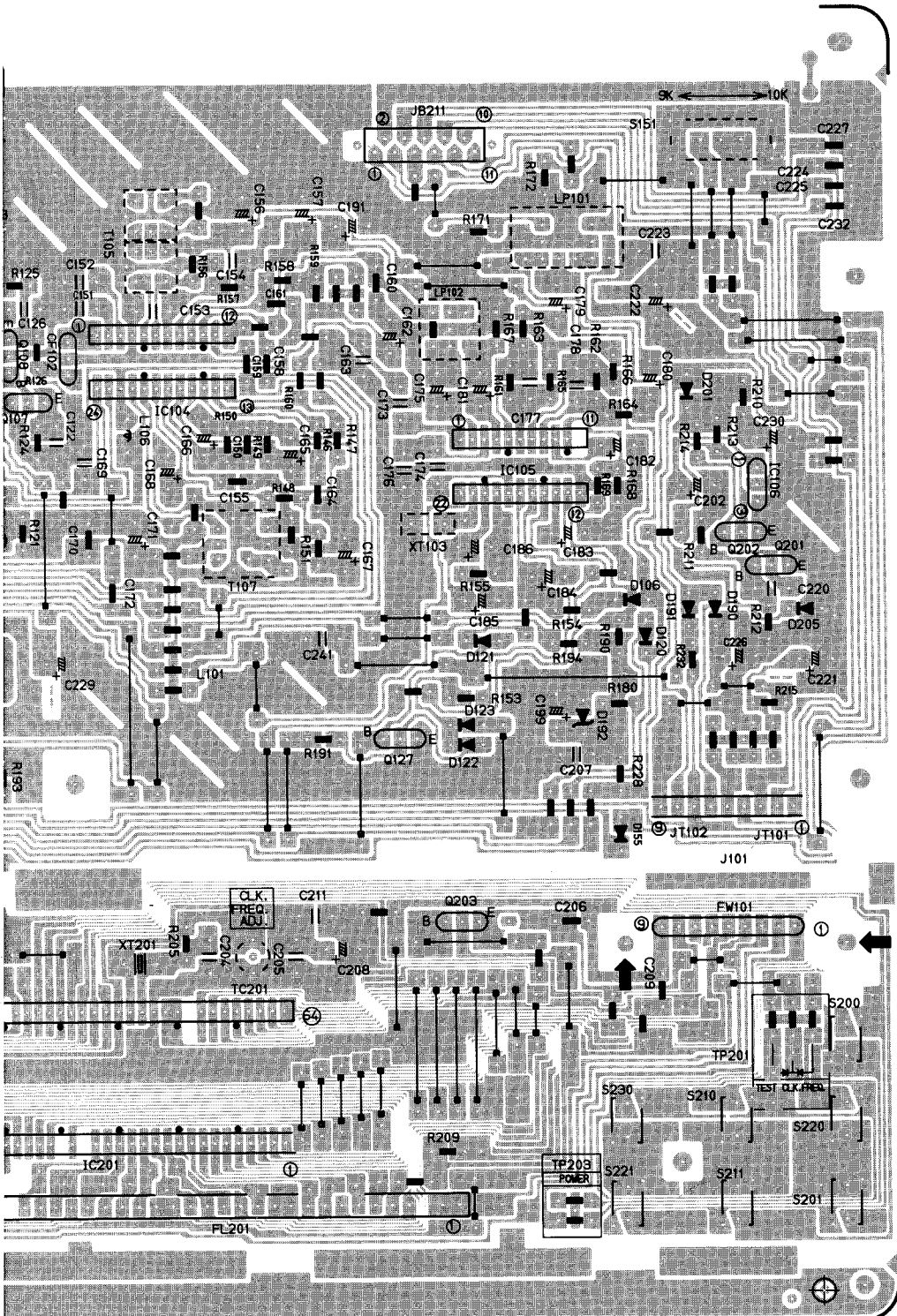

PARTS LIST

Contents

General Exploded View and Parts List	2-2
Printed Circuit Board Ass'y and Parts List	2-4
■ ENA-118 □ Tuner PC Board Ass'y	2-4
Packing Materials and Part Numbers	2-8

General Exploded View and Parts List

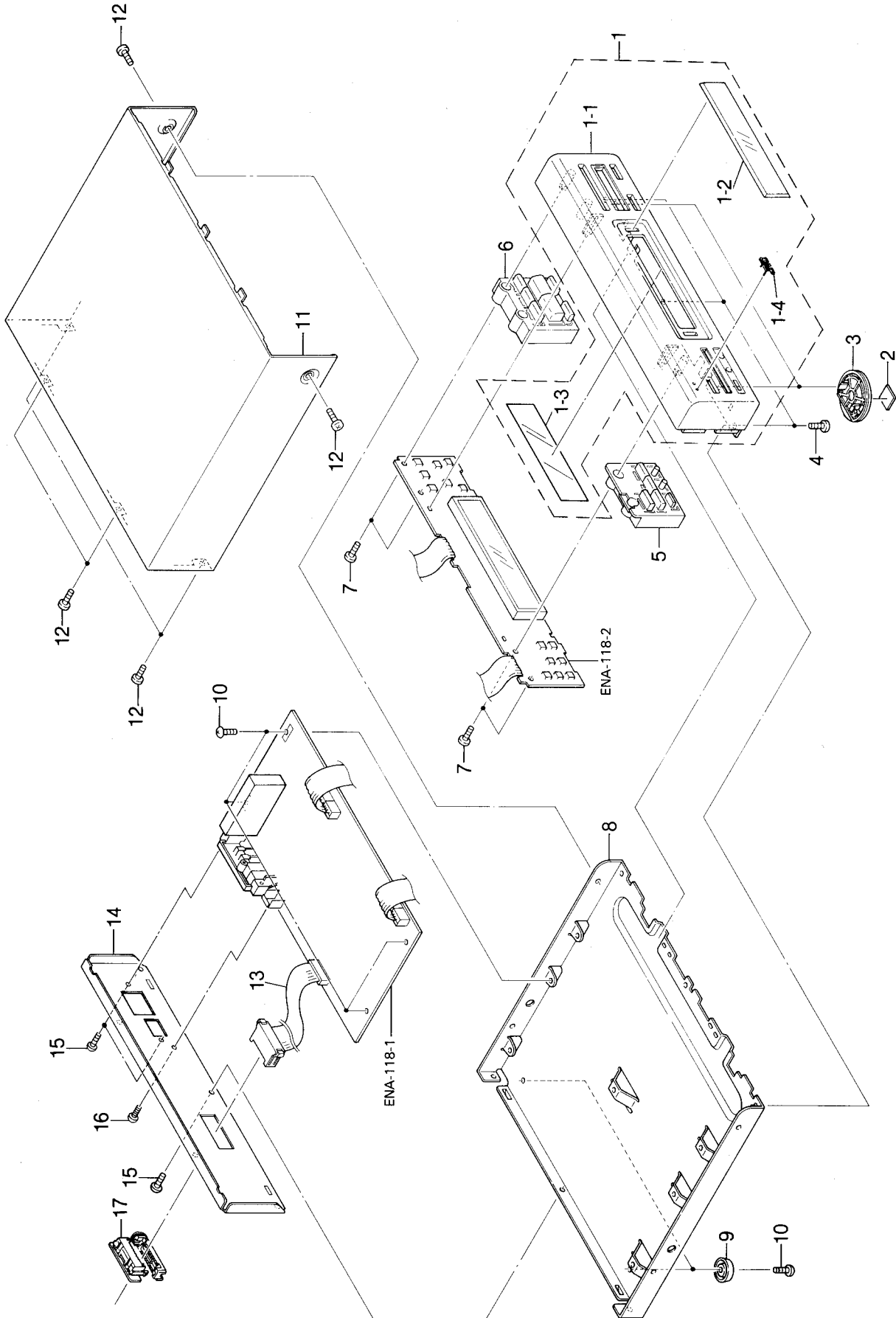

■ Parts List

△	Item	Part Number	Part Name	Q'ty	Description	Areas
	1	EFP-FXMX70BKE(S)	Front Panel Ass'y	1		
	1-1	E102331-003	Front Panel	1		
	1-2	E306956-002	Window Screen	1		
	1-3	E70561-028	FL Screen	1		
	1-4	PQ42561	JVC Mark	1		
	2	E75896-001	Spacer	2	for Front Foot	
	3	E306935-001	Foot	2	Front	
	4	SDSG3006M	Screw	3		
	5	E306952-001	Push Button	1	Tuning	
	6	E306954-002	Push Button	1	Preset	J, C, U, A
	7	E306954-003	Push Button	1	Preset	E, EF, G, GI, BS
	8	SDSF2608Z	Screw	4		
	9	E102327-002	Chassis Base	1		
	10	E47227-029	Foot	2	Rear	
	10	SBSG3008N	Screw	6		
	11	E206817-001	Metal Cover	1		
	12	SDSG3008M	Screw	6		
	13	EWP902-019	Plug Cord Ass'y	1	FW001(11Pin)	
	14	E206818-007	Rear Panel	1		J
	14	E206818-008	Rear Panel	1		C, A
	15	E206818-009	Rear Panel	1		U
	15	E206818-010	Rear Panel	1		E, EF, G, GI, BS
	16	SBSG3008M	Screw	3		
	16	SBST3008M	Screw	1		
	17	E305920-001	Cord Holder	1		
	—	E61029-009	Number Label	1		

△: Safety Parts

The Marks Designated Areas

J.....the U.S.A.
 C.....Canada
 A.....Australia
 G.....Germany
 GI.....Italy

BS.....the U.K.
 E, EF.....Continental Europe
 U.....Universal Type
 No mark indicates all areas.

Note (1)

PC Board Ass'y	Designated Areas
ENA-118 A	the U.S.A. , Canada
ENA-118 B	Universal Type
ENA-118 C	Australia
ENA-118 D	Continental Europe
ENA-118 E	Germany
ENA-118 F	the U.K.
ENA-118 G	Italy

Transistors

ITEM	PART NUMBER	DESCRIPTION	AREA
Q103	2SC461(B,C)	SILICON HITACHI	
Q107	2SC535(B,C)	SILICON HITACHI	
Q108	2SC461(B,C)	SILICON HITACHI	
Q111	2SD2144S(VW)	SILICON ROHM	D
Q111	2SD2144S(VW)	SILICON ROHM	E
Q111	2SD2144S(VW)	SILICON ROHM	F
Q111	2SD2144S(VW)	SILICON ROHM	G
Q112	2SK301(Q,R)	F.E.T MATSUSHITA	
Q113	2SK301(Q,R)	F.E.T MATSUSHITA	D
Q113	2SK301(Q,R)	F.E.T MATSUSHITA	E
Q113	2SK301(Q,R)	F.E.T MATSUSHITA	F
Q113	2SK301(Q,R)	F.E.T MATSUSHITA	G
Q114	2SK301(P,Q)	F.E.T MATSUSHITA	D
Q114	2SK301(P,Q)	F.E.T MATSUSHITA	E
Q114	2SK301(P,Q)	F.E.T MATSUSHITA	F
Q114	2SK301(P,Q)	F.E.T MATSUSHITA	G
Q115	2SK301(P,Q)	F.E.T MATSUSHITA	D
Q115	2SK301(P,Q)	F.E.T MATSUSHITA	E
Q115	2SK301(P,Q)	F.E.T MATSUSHITA	F
Q115	2SK301(P,Q)	F.E.T MATSUSHITA	G
Q121	DTA114ES	SILICON ROHM	D
Q121	DTA114ES	SILICON ROHM	E
Q121	DTA114ES	SILICON ROHM	F
Q121	DTA114ES	SILICON ROHM	G
Q123	DTA114ES	SILICON ROHM	
Q124	DTA114ES	SILICON ROHM	
Q125	2SK301(Q2)	F.E.T MATSUSHITA	
Q126	2SC458(D)	SILICON HITACHI	
Q127	DTC144ES	SILICON ROHM	
Q201	2SC1740S(R,S)	SILICON ROHM	
Q202	DTC114YS	SILICON ROHM	
Q203	DTA114YS	SILICON ROHM	

△ DISASSEMBLY PARTS

I. C. s

ITEM	PART NUMBER	DESCRIPTION	AREA
IC102	LC7218	I.C. SANYO	
IC104	LA1266A	I.C. SANYO	
IC105	LA3401	I.C. SANYO	
IC106	MN1281(P,Q)	I.C. MATSUSHITA	
IC201	HD6140B9SC35	I.C. HITACHI	

△ DISASSEMBLY PARTS

Diodes

ITEM	PART NUMBER	DESCRIPTION	AREA
D102	1SS133	SILICON ROHM	D
D102	1SS133	SILICON ROHM	E
D102	1SS133	SILICON ROHM	F
D102	1SS133	SILICON ROHM	G
D103	1SS133	SILICON ROHM	D
D103	1SS133	SILICON ROHM	E
D103	1SS133	SILICON ROHM	F
D103	1SS133	SILICON ROHM	G
D106	1SS133	SILICON ROHM	
D109	1SS133	SILICON ROHM	D
D109	1SS133	SILICON ROHM	E
D109	1SS133	SILICON ROHM	F
D109	1SS133	SILICON ROHM	G
D110	1SS133	SILICON ROHM	D
D110	1SS133	SILICON ROHM	E
D110	1SS133	SILICON ROHM	F
D110	1SS133	SILICON ROHM	G
D120	1SS133	SILICON ROHM	
D121	1SS133	SILICON ROHM	
D122	1SS133	SILICON ROHM	

△ DISASSEMBLY PARTS

Diodes

ITEM	PART NUMBER	DESCRIPTION	AREA
D123	1SS133	SILICON ROHM	
D151	1SS133	SILICON ROHM	C
D152	1SS133	SILICON ROHM	A
D153	1SS133	SILICON ROHM	B
D154	1SS133	SILICON ROHM	A
D154	1SS133	SILICON ROHM	G
D155	1SS133	SILICON ROHM	B
D190	1SS133	SILICON ROHM	
D191	1SS133	SILICON ROHM	
D192	MTZ5.1JC	ZENER ROHM	
D201	1SS133	SILICON ROHM	
D205	1SS133	SILICON ROHM	
D210	MTZ5.6JC	ZENER ROHM	
VC102	SVC342(L)	VARICAP SANYO	
VC106	SVC342(L)	VARICAP SANYO	D
VC106	SVC342(L)	VARICAP SANYO	E
VC106	SVC342(L)	VARICAP SANYO	F
VC106	SVC342(L)	VARICAP SANYO	G

△ DISASSEMBLY PARTS

Capacitors

ITEM	PART NUMBER	DESCRIPTION	AREA
C101	QCF21HP-223	0.022MF 50V CERAMIC	
C110	QCZ0205-155	1.5MF 25V CERAMIC	
C122	QCF21HP-223	0.022MF 50V CERAMIC	
C126	QCF21HP-223	0.022MF 50V CERAMIC	
C132	QCS21HJ-561	560PF 50V CERAMIC	
C133	QCF21HP-223	0.022MF 50V CERAMIC	
C134	QETB1EM-106	10MF 25V ELECTRO	
C135	QCC21EM-223	0.022MF 25V CERAMIC	
C136	QCT26CH-180	18PF 50V CERAMIC	
C137	QCT26CH-221	220PF 50V CERAMIC	
C138	QCT26CH-241	240PF 50V CERAMIC	
C139	QCC21EM-223	0.022MF 25V CERAMIC	D
C139	QCC21EM-223	0.022MF 25V CERAMIC	E
C139	QCC21EM-223	0.022MF 25V CERAMIC	F
C139	QCC21EM-223	0.022MF 25V CERAMIC	G
C141	QCS21HJ-270	27PF 50V CERAMIC	D
C141	QCS21HJ-270	27PF 50V CERAMIC	E
C141	QCS21HJ-270	27PF 50V CERAMIC	F
C141	QCS21HJ-270	27PF 50V CERAMIC	G
C142	QCY21HK-272	2700PF 50V CERAMIC	D
C142	QCY21HK-272	2700PF 50V CERAMIC	E
C142	QCY21HK-272	2700PF 50V CERAMIC	F
C142	QCY21HK-272	2700PF 50V CERAMIC	G
C143	QCHB1EZ-223	0.022MF 25V CERAMIC	D
C143	QCHB1EZ-223	0.022MF 25V CERAMIC	E
C143	QCHB1EZ-223	0.022MF 25V CERAMIC	F
C143	QCHB1EZ-223	0.022MF 25V CERAMIC	G
C144	QETB1EM-106	10MF 25V ELECTRO	D
C144	QETB1EM-106	10MF 25V ELECTRO	E
C144	QETB1EM-106	10MF 25V ELECTRO	F
C144	QETB1EM-106	10MF 25V ELECTRO	G
C146	QCT26CH-680	68PF 50V CERAMIC	D
C146	QCT26CH-680	68PF 50V CERAMIC	E
C146	QCT26CH-680	68PF 50V CERAMIC	F
C146	QCT26CH-680	68PF 50V CERAMIC	G
C147	QCT26CH-220	22PF 50V CERAMIC	D
C147	QCT26CH-220	22PF 50V CERAMIC	E
C147	QCT26CH-220	22PF 50V CERAMIC	F
C147	QCT26CH-220	22PF 50V CERAMIC	G
C148	QCT26CH-121	120PF 50V CERAMIC	D
C148	QCT26CH-121	120PF 50V CERAMIC	E
C148	QCT26CH-121	120PF 50V CERAMIC	F
C148	QCT26CH-121	120PF 50V CERAMIC	G
C149	QCF21HP-223	0.022MF 50V CERAMIC	
C150	QCHB1EZ-223	0.022MF 25V CERAMIC	
C151	QCF21HP-223	0.022MF 50V CERAMIC	
C152	QCF21HP-223	0.022MF 50V CERAMIC	
C153	QCC21EM-223	0.022MF 25V CERAMIC	
C154	QCF21HP-223	0.022MF 50V CERAMIC	
C155	QCHB1EZ-223	0.022MF 25V CERAMIC	
C156	QETB1EM-227	220MF 16V ELECTRO	
C157	QETB1EM-474	0.47MF 50V ELECTRO	
C158	QCB1HK-101	100PF 50V CERAMIC	
C159	QCB1HK-101	100PF 50V CERAMIC	
C160	QCB1HK-221	220PF 50V CERAMIC	
C161	QCHB1EZ-223	0.022MF 25V CERAMIC	
C162	QETB1EM-106	10MF 25V ELECTRO	
C163	QFN81HK-102	1000PF 50V MYLAR	
C164	QCHB1EZ-223	0.022MF 25V CERAMIC	
C165	QETB1EM-474	0.47MF 50V ELECTRO	
C166	QETB1EM-225	2.2MF 50V ELECTRO	
C167	QETB1EM-225	2.2MF 50V ELECTRO	
C168	QETB1EM-475	4.7MF 50V ELECTRO	
C169	QCF21HP-223	0.022MF 50V CERAMIC	
C170	QCHB1EZ-223	0.022MF 25V CERAMIC	
C171	QETB1EM-106	10MF 25V ELECTRO	
C172	QCVB1CM-103	0.011F 16V CERAMIC	
C173	QFN81HK-393	0.039MF 50V MYLAR	A
C173	QFN81HK-393	0.039MF 50V MYLAR	B
C173	QFN81HK-223	0.022MF 50V MYLAR	C

△ DISASSEMBLY PARTS

Capacitors

Δ	ITEM	PART NUMBER	DESCRIPTION	AREA
	C173	QFN81HK-223	0.022HF 50V MYLAR	D
	C173	QFN81HK-223	0.022HF 50V MYLAR	E
	C173	QFN81HK-223	0.022HF 50V MYLAR	F
	C173	QFN81HK-223	0.022HF 50V MYLAR	G
	C174	QFLB1HK-473	0.047HF 50V MYLAR	
	C175	QETB1EM-106	10MF 25V ELECTRO	
	C176	QCY21HK-102	1000PF 50V CERAMIC	
	C177	QCS21HJ-821	820PF 50V CERAMIC	A
	C177	QCS21HJ-821	820PF 50V CERAMIC	B
	C177	QCS21HJ-391	390PF 50V CERAMIC	C
	C177	QCS21HJ-391	390PF 50V CERAMIC	D
	C177	QCS21HJ-391	390PF 50V CERAMIC	E
	C177	QCS21HJ-561	560PF 50V CERAMIC	F
	C177	QCS21HJ-391	390PF 50V CERAMIC	G
	C178	QCS21HJ-821	820PF 50V CERAMIC	A
	C178	QCS21HJ-821	820PF 50V CERAMIC	B
	C178	QCS21HJ-391	390PF 50V CERAMIC	C
	C178	QCS21HJ-391	390PF 50V CERAMIC	D
	C178	QCS21HJ-391	390PF 50V CERAMIC	E
	C178	QCS21HJ-561	560PF 50V CERAMIC	F
	C178	QCS21HJ-391	390PF 50V CERAMIC	G
	C179	QETB1HM-225	2.2MF 50V ELECTRO	
	C180	QETB1HM-225	2.2MF 50V ELECTRO	
	C181	QETB1EM-106	10MF 25V ELECTRO	
	C182	QETB1HM-225	2.2MF 50V ELECTRO	
	C183	QETB1HM-105	1MF 50V ELECTRO	
	C184	QETB1HM-105	1MF 50V ELECTRO	
	C185	QETB1HM-225	2.2MF 50V ELECTRO	
	C186	QETB1HM-474	0.47HF 50V ELECTRO	
	C191	QETB1HM-475	4.7MF 50V ELECTRO	
	C192	QCC21EM-473	0.047HF 25V CERAMIC	
	C193	QCS21HJ-180	18PF 50V CERAMIC	
	C194	QCS21HJ-180	18PF 50V CERAMIC	
	C195	QEN51HM-474	0.47HF 50V NON POLE	
	C196	QCY21HK-102	1000PF 50V CERAMIC	
	C197	QCF21HP-223	0.022HF 50V CERAMIC	
	C198	QCF21HP-103	0.01HF 50V CERAMIC	
	C199	QETB1HM-475	4.7MF 50V ELECTRO	
	C202	QETB1HM-225	2.2MF 50V ELECTRO	
	C204	QCT26CH-120	12PF 50V CERAMIC	
	C205	QCZ0202-155	1.5MF 25V CERAMIC	
	C206	QCVB1CM-103	0.01MF 16V CERAMIC	
	C207	QCF21HP-223	0.022MF 50V CERAMIC	
	C208	QEK61AM-227Z	220MF 10V ELECTRO	
	C209	QCVB1CM-103	0.01MF 16V CERAMIC	
	C210	QCVB1CM-103	0.01MF 16V CERAMIC	
	C211	QCF21HP-103	0.01MF 50V CERAMIC	
	C220	QCF21HP-103	0.01MF 50V CERAMIC	
	C221	QEA40HZ-10AB	ELECTRO	
	C222	QETB1CM-477	470MF 16V ELECTRO	
	C223	QCF21HP-103	0.01MF 50V CERAMIC	
	C224	QCGB1HK-102	1000PF 50V CERAMIC	
	C225	QCGB1HK-102	1000PF 50V CERAMIC	
	C226	QETB1AM-227	220MF 10V ELECTRO	
	C227	QCVB1CM-103	0.01MF 16V CERAMIC	
	C229	QETB1CM-477	470MF 16V ELECTRO	
	C230	QETB1EM-476	47MF 25V ELECTRO	
	C232	QCVB1CM-103	0.01MF 16V CERAMIC	
	C241	QCF21HP-223	0.022MF 50V CERAMIC	

Δ ISIAFETIYI PARTS

Resistors

Δ	ITEM	PART NUMBER	DESCRIPTION	AREA
	R144	QRD167J-473	47K 1/6W CARBON	E
	R144	QRD167J-473	47K 1/6W CARBON	F
	R144	QRD167J-473	47K 1/6W CARBON	G
	R145	QRD167J-103	10K 1/6W CARBON	D
	R145	QRD167J-103	10K 1/6W CARBON	E
	R145	QRD167J-103	10K 1/6W CARBON	F
	R145	QRD167J-103	10K 1/6W CARBON	G
	R146	QRD167J-560	56 1/6W CARBON	
	R147	QRD167J-103	10K 1/6W CARBON	
	R148	QRD167J-103	10K 1/6W CARBON	
	R149	QRD167J-223	22K 1/6W CARBON	
	R150	QRD167J-103	10K 1/6W CARBON	
	R151	QRD167J-222	2.2K 1/6W CARBON	
	R153	QRD167J-103	10K 1/6W CARBON	
	R154	QRD167J-103	10K 1/6W CARBON	
	R155	QRD167J-562	5.6K 1/6W CARBON	
	R156	QRD167J-822	8.2K 1/6W CARBON	
	R157	QRD167J-103	10K 1/6W CARBON	
	R158	QRD167J-183	18K 1/6W CARBON	A
	R158	QRD167J-273	27K 1/6W CARBON	B
	R158	QRD167J-273	27K 1/6W CARBON	C
	R158	QRD167J-273	27K 1/6W CARBON	D
	R158	QRD167J-273	27K 1/6W CARBON	E
	R158	QRD167J-273	27K 1/6W CARBON	F
	R158	QRD167J-273	27K 1/6W CARBON	G
	R159	QRD167J-561	560 1/6W CARBON	
	R160	QRD167J-562	5.6K 1/6W CARBON	A
	R160	QRD167J-562	5.6K 1/6W CARBON	B
	R160	QRD167J-183	18K 1/6W CARBON	C
	R160	QRD167J-183	18K 1/6W CARBON	D
	R160	QRD167J-183	18K 1/6W CARBON	E
	R160	QRD167J-822	8.2K 1/6W CARBON	F
	R160	QRD167J-183	18K 1/6W CARBON	G
	R161	QRD167J-823	82K 1/6W CARBON	A
	R161	QRD167J-823	82K 1/6W CARBON	B
	R161	QRD167J-124	120K 1/6W CARBON	C
	R161	QRD167J-124	120K 1/6W CARBON	D
	R161	QRD167J-124	120K 1/6W CARBON	E
	R161	QRD167J-823	82K 1/6W CARBON	F
	R161	QRD167J-124	120K 1/6W CARBON	G
	R162	QRD167J-823	82K 1/6W CARBON	A
	R162	QRD167J-823	82K 1/6W CARBON	B
	R162	QRD167J-124	120K 1/6W CARBON	C
	R162	QRD167J-124	120K 1/6W CARBON	D
	R162	QRD167J-124	120K 1/6W CARBON	E
	R162	QRD167J-823	82K 1/6W CARBON	F
	R162	QRD167J-124	120K 1/6W CARBON	G
	R163	QRD167J-472	4.7K 1/6W CARBON	A
	R163	QRD167J-472	4.7K 1/6W CARBON	B
	R163	QRD167J-332	3.3K 1/6W CARBON	C
	R163	QRD167J-332	3.3K 1/6W CARBON	D
	R163	QRD167J-332	3.3K 1/6W CARBON	E
	R163	QRD167J-332	3.3K 1/6W CARBON	F
	R163	QRD167J-332	3.3K 1/6W CARBON	G
	R164	QRD167J-472	4.7K 1/6W CARBON	A
	R164	QRD167J-472	4.7K 1/6W CARBON	B
	R164	QRD167J-332	3.3K 1/6W CARBON	C
	R164	QRD167J-332	3.3K 1/6W CARBON	D
	R164	QRD167J-332	3.3K 1/6W CARBON	E
	R164	QRD167J-332	3.3K 1/6W CARBON	F
	R164	QRD167J-332	3.3K 1/6W CARBON	G
	R165	QRD167J-184	180K 1/6W CARBON	A
	R165	QRD167J-184	180K 1/6W CARBON	B
	R165	QRD167J-274	270K 1/6W CARBON	C
	R165	QRD167J-274	270K 1/6W CARBON	D
	R165	QRD167J-274	270K 1/6W CARBON	E
	R165	QRD167J-274	270K 1/6W CARBON	F
	R165	QRD167J-274	270K 1/6W CARBON	G
	R165	QRD167J-274	270K 1/6W CARBON	
	R166	QRD167J-184	180K 1/6W CARBON	A
	R166	QRD167J-184	180K 1/6W CARBON	B
	R166	QRD167J-274	270K 1/6W CARBON	C
	R166	QRD167J-274	270K 1/6W CARBON	D
	R166	QRD167J-274	270K 1/6W CARBON	E
	R166	QRD167J-274	270K 1/6W CARBON	F
	R166	QRD167J-274	270K 1/6W CARBON	G
	R167	QRD167J-393	39K 1/6W CARBON	A
	R167	QRD167J-393	39K 1/6W CARBON	B
	R167	QRD167J-473	47K 1/6W CARBON	C
	R167	QRD167J-473	47K 1/6W CARBON	D
	R167	QRD167J-473	47K 1/6W CARBON	E
	R167	QRD167J-473	47K 1/6W CARBON	F
	R167	QRD167J-473	47K 1/6W CARBON	G
	R168	QRD167J-103	10K 1/6W CARBON	
	R169	QRD167J-103	10K 1/6W CARBON	
	R171	QRD167J-682	6.8K 1/6W CARBON	
	R172	QRD167J-682	6.8K 1/6W CARBON	
	R180	QRD167J-103	10K 1/6W CARBON	
	R181	QRD167J-222	2.2K 1/6W CARBON	
	R182	QRD167J-181	180 1/6W CARBON	
	R190	QRD167J-103	10K 1/6W CARBON	
	R191	QRD167J-562	5.6K 1/6W CARBON	
	R193	QRD167J-103	10K 1/6W CARBON	
	R194	QRD167J-103	10K 1/6W CARBON	
	R195	QRD167J-473	47K 1/6W CARBON	
	R196	QRD167J-103	10K 1/6W CARBON	A

Δ ISIAFETIYI PARTS

Resistors

Δ	ITEM	PART NUMBER	DESCRIPTION	AREA
	R118	QRD167J-332	3.3K 1/6W CARBON	
	R119	QRD167J-221	220 1/6W CARBON	
	R121	QRD167J-391	390 1/6W CARBON	
	R122	QRD167J-272	2.7K 1/6W CARBON	
	R123	QRD167J-102	1K 1/6W CARBON	
	R124	QRD167J-681	680 1/6W CARBON	
	R125	QRD167J-332	3.3K 1/6W CARBON	
	R126	QRD167J-221	220 1/6W CARBON	
	R131	QRD167J-331	330 1/6W CARBON	
	R132	QRD167J-103	10K 1/6W CARBON	
	R133	QRD167J-473	47K 1/6W CARBON	
	R134	QRD167J-103	10K 1/6W CARBON	D
	R134	QRD167J-103	10K 1/6W CARBON	E
	R134	QRD167J-103	10K 1/6W CARBON	F
	R134	QRD167J-103	10K 1/6W CARBON	G
	R135	QRD167J-470	47 1/6W CARBON	
	R136	QRD167J-103	10K 1/6W CARBON	
	R141	QRD167J-472	4.7K 1/6W CARBON	D
	R141	QRD167J-472	4.7K 1/6W CARBON	E
	R141	QRD167J-472	4.7K 1/6W CARBON	F
	R141	QRD167J-472	4.7K 1/6W CARBON	G
	R142	QRD167J-331	330 1/6W CARBON	D
	R142	QRD167J-331	330 1/6W CARBON	E
	R142	QRD167J-331	330 1/6W CARBON	F
	R142	QRD167J-331	330 1/6W CARBON	G
	R143	QRD167J-103	10K 1/6W CARBON	D
	R143	QRD167J-103	10K 1/6W CARBON	E
	R143	QRD167J-103	10K 1/6W CARBON	F
	R143	QRD167J-103	10K 1/6W CARBON	G
	R144	QRD167J-473	47K 1/6W CARBON	D

Δ ISIAFETIYI PARTS

Resistors

ITEM	PART NUMBER	DESCRIPTION	AREA
R196	QRD167J-103	10K 1/6W CARBON	B
R196	QRD167J-103	10K 1/6W CARBON	C
R196	QRD167J-222	2.2K 1/6W CARBON	D
R196	QRD167J-222	2.2K 1/6W CARBON	E
R196	QRD167J-222	2.2K 1/6W CARBON	F
R196	QRD167J-222	2.2K 1/6W CARBON	G
R198	QRD167J-332	3.3K 1/6W CARBON	A
R198	QRD167J-332	3.3K 1/6W CARBON	B
R198	QRD167J-332	3.3K 1/6W CARBON	C
R198	QRD167J-822	8.2K 1/6W CARBON	D
R198	QRD167J-822	8.2K 1/6W CARBON	E
R198	QRD167J-822	8.2K 1/6W CARBON	F
R198	QRD167J-822	8.2K 1/6W CARBON	G
R199	QRD167J-472	4.7K 1/6W CARBON	
R205	QRD167J-473	47K 1/6W CARBON	
R209	QRD167J-104	100K 1/6W CARBON	
R210	QRD167J-222	2.2K 1/6W CARBON	
R211	QRD167J-103	10K 1/6W CARBON	
R212	QRD167J-473	47K 1/6W CARBON	
R213	QRD167J-472	4.7K 1/6W CARBON	
R214	QRD167J-102	1K 1/6W CARBON	
R215	QRD167J-470	47 1/6W CARBON	
R228	QRD167J-222	2.2K 1/6W CARBON	
R229	QRD14CJ-220S	22 1/4W UNF. CARBON	
R232	QRD167J-153	15K 1/6W CARBON	

△ SAFETY PARTS

Others

ITEM	PART NUMBER	DESCRIPTION	AREA
FE101	EAF2203-003	FRONT END	E
FE101	EAF2203-003	FRONT END	F
FE101	EAF2203-003	FRONT END	G
FL201	ELU0001-101	FL TUBE	
FS201	E306805-021	FELT SPACER	
FW001	EW902-019	PLUG WIRE ASSY	
FW101	EWR39B-25LST	FLAT WIRE(9PIN)	
FW102	EWR39B-25LST	FLAT WIRE(9PIN)	
JB211	EMV7130-011	CONNECTOR(11PIN)	
JT101	EMV7122-004	CONNECTOR(4PIN)	
JT102	EMV7122-005	CONNECTOR(5PIN)	
JT103	EMV7122-004	CONNECTOR(4PIN)	
JT104	EMV7122-005	CONNECTOR(5PIN)	
LP101	EQF0101-002	LOW PASS FILTER	
LP102	EQF0102-001	LOW PASS FILTER	D
LP102	EQF0102-001	LOW PASS FILTER	E
LP102	EQF0102-001	LOW PASS FILTER	F
LP102	EQF0102-001	LOW PASS FILTER	G
TC105	ENZ1003-006	TRIMMER	
TC106	ENZ1003-006	TRIMMER	D
TC106	ENZ1003-006	TRIMMER	E
TC106	ENZ1003-006	TRIMMER	F
TC106	ENZ1003-006	TRIMMER	G
TC201	ENZ1003-015	TRIMMER	
XT102	ECX0007-200KC	RESONATOR	
XT103	ECX0000-456KR	RESONATOR	
XT201	ECX4194-304CF	RESONATOR	

△ SAFETY PARTS

Others

ITEM	PART NUMBER	DESCRIPTION	AREA
L101	EMW10101-002	PRINTED BOARD	
L106	EQL4004-1R0	INDUCTOR	
L120	EQL3001-102K	INDUCTOR	
L120	EQL4004-1R0	INDUCTOR	
S151	QSS6A12-E01	SLIDE SWITCH(AM CH. SPACE)	B
S200	ESP0001-018	TACT SWITCH(WAKE-UP/SLEEP)	
S201	ESP0001-018	TACT SWITCH(CLOCK ADJ)	
S202	ESP0001-018	TACT SWITCH(UP)	
S210	ESP0001-018	TACT SWITCH(TIMER 2)	
S211	ESP0001-018	TACT SWITCH(CANCEL)	
S212	ESP0001-018	TACT SWITCH(DOWN)	
S214	ESP0001-018	TACT SWITCH(AM)	
S220	ESP0001-018	TACT SWITCH(TIMER 1)	
S221	ESP0001-018	TACT SWITCH(MEMORY)	
S222	ESP0001-018	TACT SWITCH(PRESET DOWN)	
S224	ESP0001-018	TACT SWITCH(PH)	
S230	ESP0001-018	TACT SWITCH(DAILY)	
S232	ESP0001-018	TACT SWITCH(PRESET UP)	
S234	ESP0001-018	TACT SWITCH(FM MODE/MUTE)	
T101	EQR1111-014	AM RF COIL	
T102	EQR1111-005	AM RF COIL	D
T102	EQR1111-005	AM RF COIL	E
T102	EQR1111-005	AM RF COIL	F
T102	EQR1111-005	AM RF COIL	G
T103	EQR1207-017	MW OSC COIL	
T104	EQR1307-010	LW OSC COIL	D
T104	EQR1307-010	LW OSC COIL	E
T104	EQR1307-010	LW OSC COIL	F
T104	EQR1307-010	LW OSC COIL	G
T105	EQT2140-017	L.F. TRANSFORMER	
T107	ECB1560-008	CERAMIC FILTER	
AT101	EMB41YV-401K	ANTENNA TERMINAL	A
AT101	EMB41YV-401K	ANTENNA TERMINAL	B
AT101	EMB41YV-401K	ANTENNA TERMINAL	C
AT101	EMB41YV-301K	ANTENNA TERMINAL	D
AT101	EMB41YV-301K	ANTENNA TERMINAL	E
AT101	EMB41YV-301K	ANTENNA TERMINAL	F
AT101	EMB41YV-301K	ANTENNA TERMINAL	G
BK201	E306958-002	FL DISPLAY HOLDER	
CF101	ECB2123-006R	CERAMIC FILTER	A
CF101	ECB2123-006R	CERAMIC FILTER	B
CF101	ECB2123-006R	CERAMIC FILTER	C
CF101	ECB2118-007R	CERAMIC FILTER	D
CF101	ECB2118-007R	CERAMIC FILTER	E
CF101	ECB2118-007R	CERAMIC FILTER	F
CF101	ECB2118-007R	CERAMIC FILTER	G
CF102	ECB2123-006R	CERAMIC FILTER	A
CF102	ECB2123-006R	CERAMIC FILTER	B
CF102	ECB2123-006R	CERAMIC FILTER	C
CF102	ECB2118-007R	CERAMIC FILTER	D
CF102	ECB2118-007R	CERAMIC FILTER	E
CF102	ECB2118-007R	CERAMIC FILTER	F
CF102	ECB2118-007R	CERAMIC FILTER	G
EP102	E70859-001	EARTH PLATE	
EP103	E70859-001	EARTH PLATE	
EP110	E70225-001	EARTH PLATE	
FE101	EAF2203-001	FRONT END	A
FE101	EAF2203-001	FRONT END	B
FE101	EAF2203-001	FRONT END	C
FE101	EAF2203-003	FRONT END	D

△ SAFETY PARTS

Packing Materials and Part Numbers

(Only for Continental Europe , the U.K. , Germany , Italy)

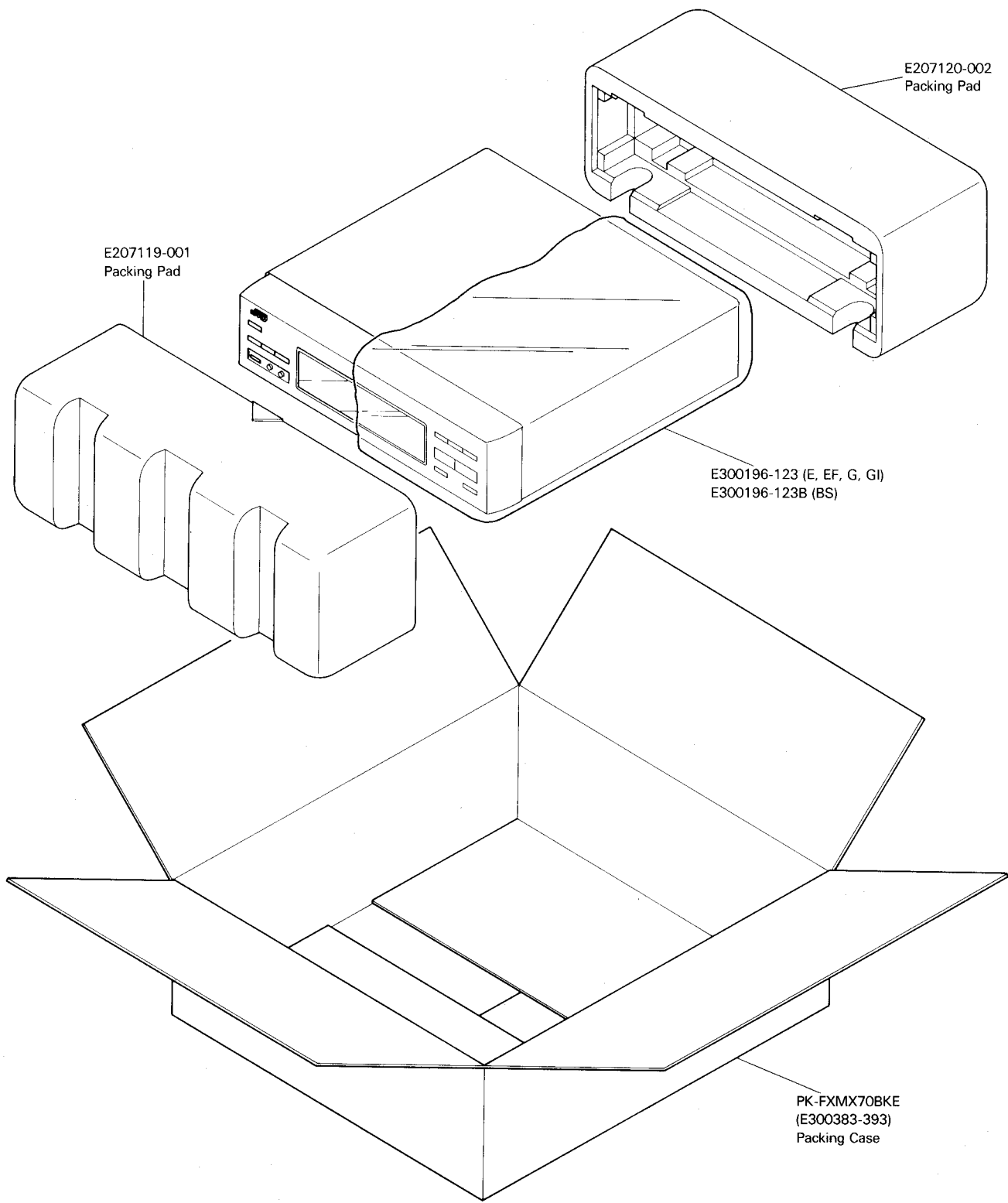

E207119-001
Packing Pad

E207120-002
Packing Pad

E300196-123 (E, EF, G, GI)
E300196-123B (BS)

PK-FXMX70BKE
(E300383-393)
Packing Case

The Marks Designated Areas	
G.....Germany	E , EF.....Continental Europe
BS.....the U.K.	No mark indicates all areas.
GI.....Italy	

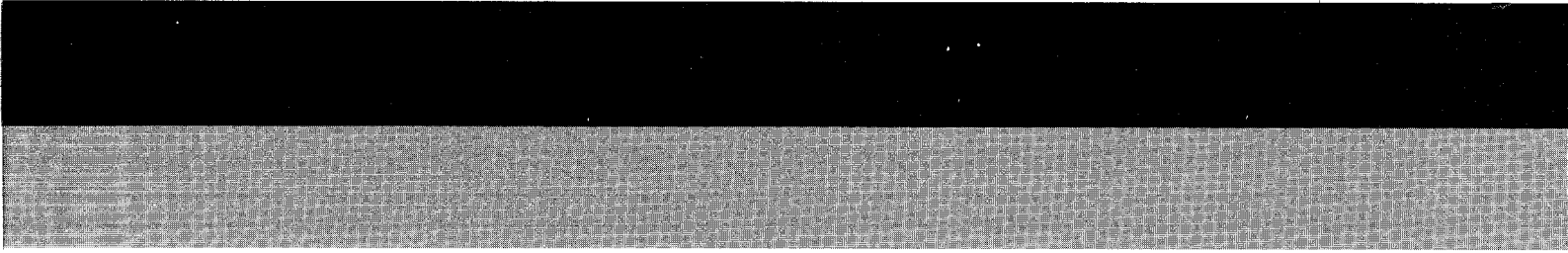

JVC

VICTOR COMPANY OF JAPAN, LIMITED
AUDIO PRODUCTS DIVISION, YAMATO PLANT, 1644, SHIMOTSURUMA, YAMATO-SHI, KANAGAWA-KEN, 242, JAPAN

