

JVC

SERVICE MANUAL

COMPACT COMPONENT SYSTEM

HX-Z1

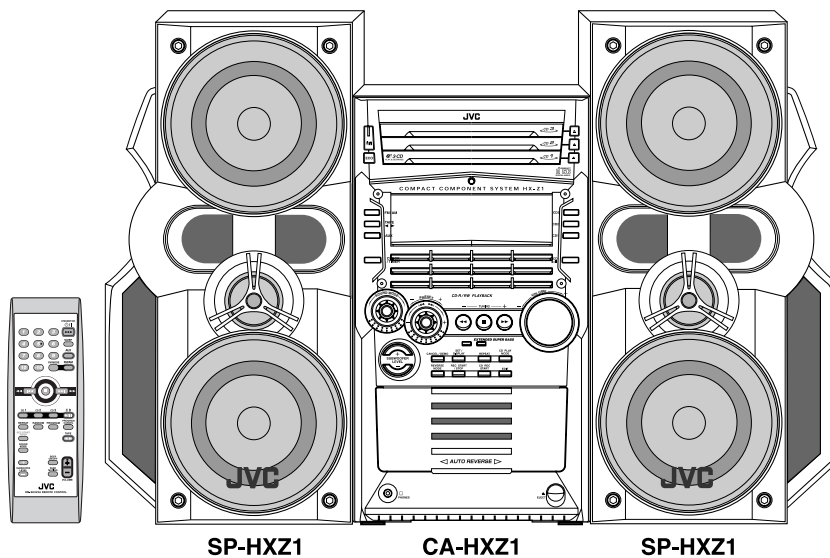

COMPACT
disc
DIGITAL AUDIO

Area Suffix

J U.S.A.
C Canada

Contents

Safety precautions	1-2	Adjustment method	1-24
Preventing static electricity	1-3	Flow of functional operation	
Important for laser products	1-4	until TOC read (CD)	1-29
Importance administering		Maintenance of laser pickup	1-30
point on the safety	1-5	Replacement of laser pickup	1-30
Disassembly method	1-6	Description of major ICs	1-31~41

Safety Precautions

1. This design of this product contains special hardware and many circuits and components specially for safety purposes. For continued protection, no changes should be made to the original design unless authorized in writing by the manufacturer. Replacement parts must be identical to those used in the original circuits. Services should be performed by qualified personnel only.
2. Alterations of the design or circuitry of the product should not be made. Any design alterations of the product should not be made. Any design alterations or additions will void the manufacturer's warranty and will further relieve the manufacture of responsibility for personal injury or property damage resulting therefrom.
3. Many electrical and mechanical parts in the products have special safety-related characteristics. These characteristics are often not evident from visual inspection nor can the protection afforded by them necessarily be obtained by using replacement components rated for higher voltage, wattage, etc. Replacement parts which have these special safety characteristics are identified in the Parts List of Service Manual. Electrical components having such features are identified by shading on the schematics and by (\triangle) on the Parts List in the Service Manual. The use of a substitute replacement which does not have the same safety characteristics as the recommended replacement parts shown in the Parts List of Service Manual may create shock, fire, or other hazards.
4. The leads in the products are routed and dressed with ties, clamps, tubings, barriers and the like to be separated from live parts, high temperature parts, moving parts and/or sharp edges for the prevention of electric shock and fire hazard. When service is required, the original lead routing and dress should be observed, and it should be confirmed that they have been returned to normal, after re-assembling.
5. Leakage current check (Electrical shock hazard testing)

After re-assembling the product, always perform an isolation check on the exposed metal parts of the product (antenna terminals, knobs, metal cabinet, screw heads, headphone jack, control shafts, etc.) to be sure the product is safe to operate without danger of electrical shock.

Do not use a line isolation transformer during this check.

- Plug the AC line cord directly into the AC outlet. Using a "Leakage Current Tester", measure the leakage current from each exposed metal parts of the cabinet, particularly any exposed metal part having a return path to the chassis, to a known good earth ground. Any leakage current must not exceed 0.5mA AC (r.m.s.).

- Alternate check method

Plug the AC line cord directly into the AC outlet. Use an AC voltmeter having, 1,000 ohms per volt or more sensitivity in the following manner. Connect a 1,500 Ω 10W resistor paralleled by a 0.15 μ F AC-type capacitor between an exposed metal part and a known good earth ground.

Measure the AC voltage across the resistor with the AC voltmeter.

Move the resistor connection to each exposed metal part, particularly any exposed metal part having a return path to the chassis, and measure the AC voltage across the resistor. Now, reverse the plug in the AC outlet and repeat each measurement. Voltage measured any must not exceed 0.75 V AC (r.m.s.). This corresponds to 0.5 mA AC (r.m.s.).

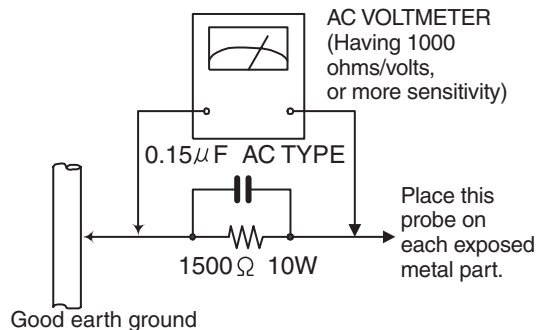

Warning

1. This equipment has been designed and manufactured to meet international safety standards.
2. It is the legal responsibility of the repairer to ensure that these safety standards are maintained.
3. Repairs must be made in accordance with the relevant safety standards.
4. It is essential that safety critical components are replaced by approved parts.
5. If mains voltage selector is provided, check setting for local voltage.

CAUTION

Burrs formed during molding may be left over on some parts of the chassis. Therefore, pay attention to such burrs in the case of preforming repair of this system.

In regard with component parts appearing on the silk-screen printed side (parts side) of the PWB diagrams, the parts that are printed over with black such as the resistor (\blacksquare), diode (\blacksquare) and ICP (\bullet) or identified by the (\triangle) mark nearby are critical for safety.

(This regulation does not correspond to J and C version.)

Preventing static electricity

1. Grounding to prevent damage by static electricity

Electrostatic discharge (ESD), which occurs when static electricity stored in the body, fabric, etc. is discharged, can destroy the laser diode in the traverse unit (optical pickup). Take care to prevent this when performing repairs.

2. About the earth processing for the destruction prevention by static electricity

In the equipment which uses optical pick-up (laser diode), optical pick-up is destroyed by the static electricity of the work environment.

Be careful to use proper grounding in the area where repairs are being performed.

2-1 Ground the workbench

Ground the workbench by laying conductive material (such as a conductive sheet) or an iron plate over it before placing the traverse unit (optical pickup) on it.

2-2 Ground yourself

Use an anti-static wrist strap to release any static electricity built up in your body.

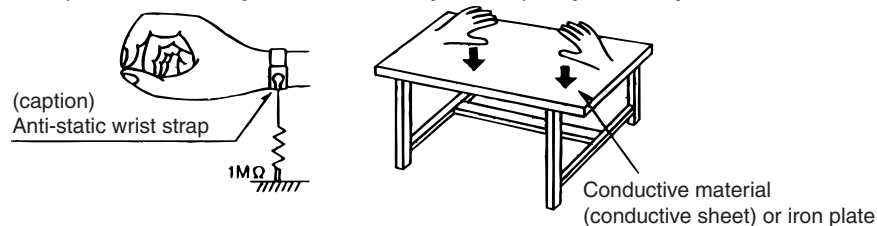

3. Handling the optical pickup

1. In order to maintain quality during transport and before installation, both sides of the laser diode on the replacement optical pickup are shorted. After replacement, return the shorted parts to their original condition. (Refer to the text.)
2. Do not use a tester to check the condition of the laser diode in the optical pickup. The tester's internal power source can easily destroy the laser diode.

4. Handling the traverse unit (optical pickup)

1. Do not subject the traverse unit (optical pickup) to strong shocks, as it is a sensitive, complex unit.
2. Cut off the shorted part of the flexible cable using nippers, etc. after replacing the optical pickup. For specific details, refer to the replacement procedure in the text. Remove the anti-static pin when replacing the traverse unit. Be careful not to take too long a time when attaching it to the connector.
3. Handle the flexible cable carefully as it may break when subjected to strong force.
4. It is not possible to adjust the semi-fixed resistor that adjusts the laser power. Do not turn it

Attention when traverse unit is decomposed

***Please refer to "Disassembly method" in the text for pick-up and how to detach the CD traverse mechanism.**

1. Remove the disk stopper and T. bracket on the CD changer mechanism assembly.
2. Disconnect the harness from connector on the CD motor board.
3. CD traverse unit is put up as shown in Fig. 1.
4. Solder is put up before the card wire is removed from connector CN601 on the CD servo control board as shown in Fig. 2.
(When the wire is removed without putting up solder, the CD pick-up assembly might destroy.)
5. Please remove solder after connecting the card wire with CN601 when you install picking up in the substrate.

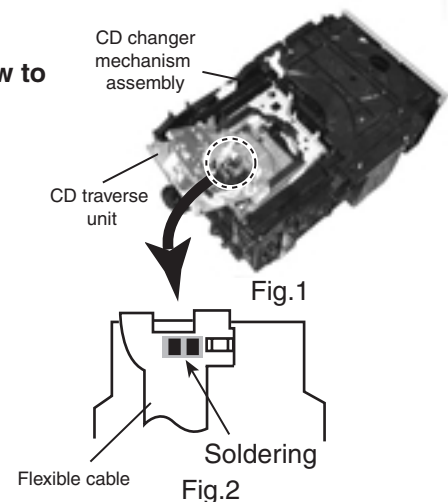

Important for laser products

1.CLASS 1 LASER PRODUCT

2.DANGER : Invisible laser radiation when open and interlock failed or defeated. Avoid direct exposure to beam.

3.CAUTION : There are no serviceable parts inside the Laser Unit. Do not disassemble the Laser Unit. Replace the complete Laser Unit if it malfunctions.

4.CAUTION : The compact disc player uses invisible laserradiation and is equipped with safety switches which prevent emission of radiation when the drawer is open and the safety interlocks have failed or are defeated. It is dangerous to defeat the safety switches.

5.CAUTION : If safety switches malfunction, the laser is able to function.

6.CAUTION : Use of controls, adjustments or performance of procedures other than those specified herein may result in hazardous radiation exposure.

⚠ CAUTION Please use enough caution not to see the beam directly or touch it in case of an adjustment or operation check.

WARNING : Osynlig laserstråling är denna del är öppnad och spårren är urkopplad. Betrakta ej strålen.

VARO : Avattaessa ja suojalukitus ohitettaessa olet alttiina näkymättömälle lasersäteilylle. Älä katso säteeseen.

ADVARSEL : Usynlig laserstråling ved åbning , når sikkerhedsafbrydere er ude af funktion. Undgå udsættelse for stråling.

ADVARSEL : Usynlig laserstråling ved åpning,når sikkerhetsbryteren er avslott. unngå utsettelse for stråling.

REPRODUCTION AND POSITION OF LABELS

WARNING LABEL

**CLASS 1
LASER PRODUCT**



CAUTION : Invisible laser radiation when open and interlock failed or defeated. AVOID DIRECT EXPOSURE TO BEAM. (e)

WARNING : Osynlig laserstråling nr denna del r pppnad och spårren r urkopplad. Betrakta ej strålen. (s)

ADVARSEL : Usynlig laserstråling ved åbning, nr sikkerhedsafbrydere er ude af funktion. Undgå udsættelse for stråling. (d)

VARO : Avattaessa ja suojalukitus ohitettaessa olet alttiina näkymättömälle lasersäteilylle. Älä katso säteeseen. (f)

E406507-001

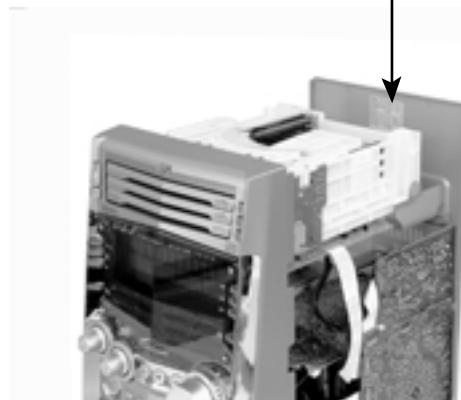

Importance administering point on the safety

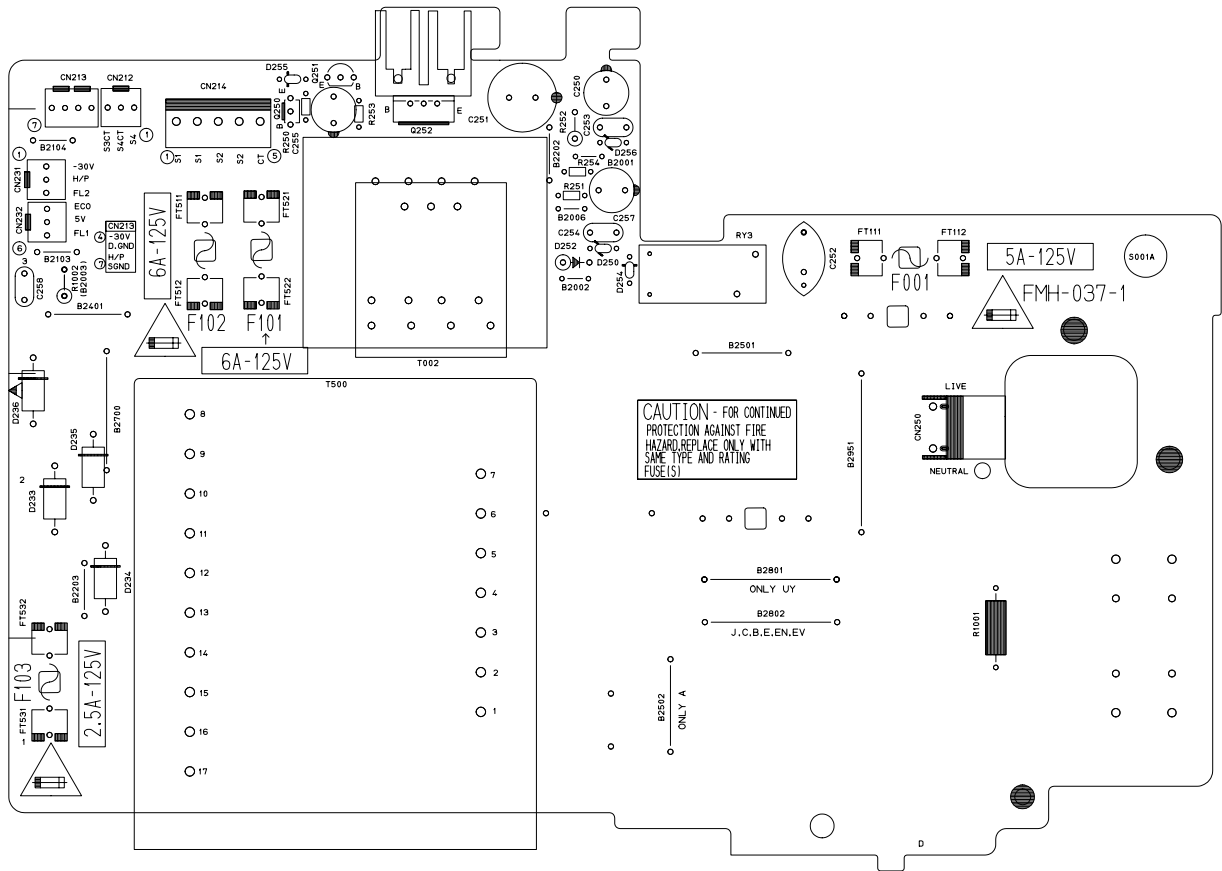

For USA and Canada / pour États - Unis d'Amérique et Canada

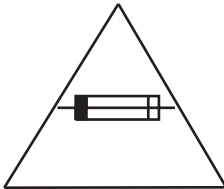

Caution: For continued protection against risk of fire, replace only with same type 2.5A/125V for F103, 5A/125V for F001 and 6A/125V for F101, F102. This symbol specifies type of fast operating fuse.

Précaution: Pour éviter des risques de feu, remplacez le fusible de sûreté de F103 comme le même type que 2.5A/125V, et 5A/125V pour F001 et 6A/125V pour F101, F102. Ce sont des fusibles sûretés qui fonctionnent rapidement.

Disassembly method

<Main board>

■ Removing the metal cover

(See Fig.1 ~ 3)

1. Remove the six screws **A** on the back of the body.
2. Remove the screw **B** on each side of the body.
3. Remove the metal cover from the body by lifting the rear part of the cover.

CAUTION: Do not break the front panel tab fitted to the metal cover.

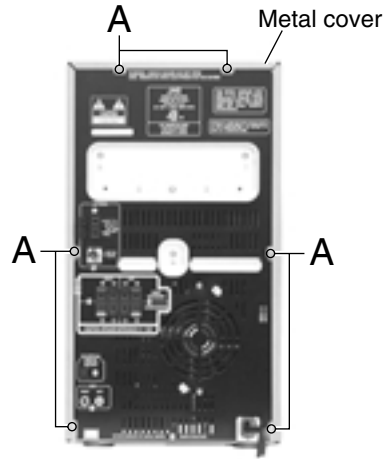

Fig.1

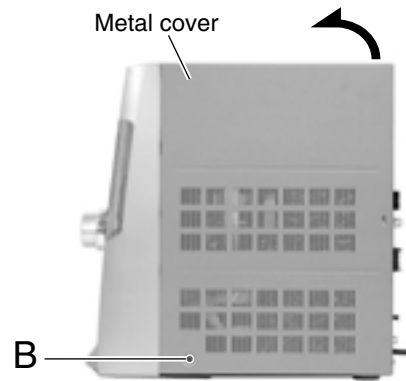

Fig.2

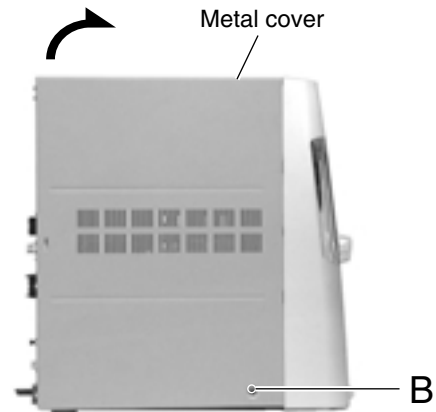

Fig.3

■ Removing the CD changer mechanism assembly

(See Fig.4, 5)

- Prior to performing the following procedure, remove the metal cover.
1. Disconnect the card wire from connector CN651 on the CD servo control board on the right bottom of the CD changer mechanism assembly.
 2. Remove the four screws **C** attaching the CD changer mechanism assembly on top of the body.
 3. Remove the CD changer mechanism assembly while lifting the rear part.

CAUTION: Do not damage the CD fitting when removing the CD changer mechanism assembly.

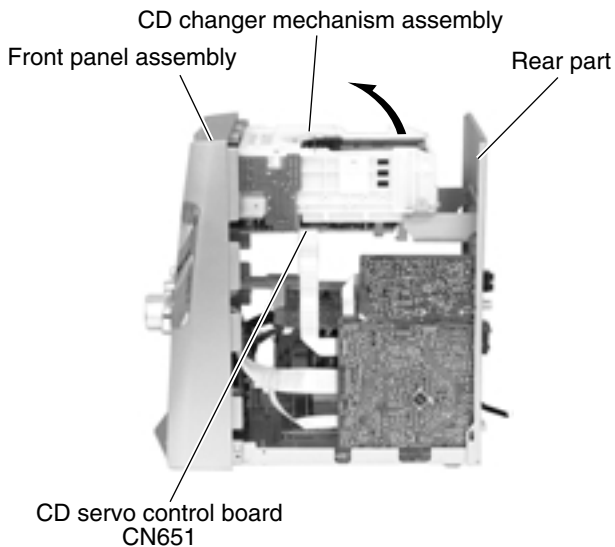

Fig.4

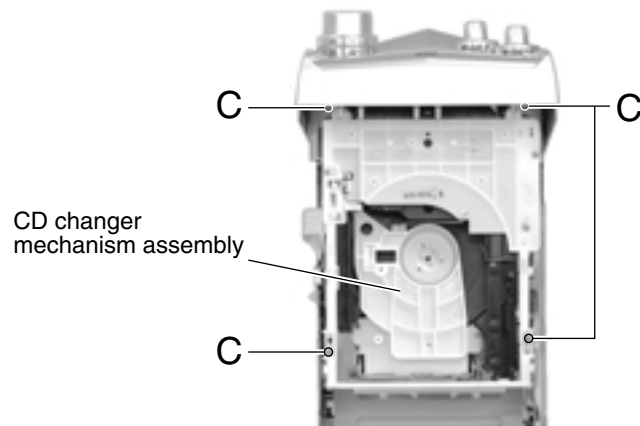

Fig.5

■ Removing the front panel assembly (See Fig.6 ~ 9)

- Prior to performing the following procedure, remove the metal cover and the CD changer mechanism assembly.
1. Disconnect the card wire from connector CN44 and CN870 on the main board on the right side of the body. Remove the screw **D** attaching the wire from extending from the underside of the front panel assembly.
 2. Disconnect the wire from connector CN701 on the bridge board.
 3. Cut the tie band.
 4. Disconnect the wire from connector CN231 and CN232 on the primary board on the left side of the body and remove the band fixing the wire.
 5. Remove the plastic rivet attaching the inner bar in the center of the front panel assembly.

REFERENCE: Keep the plastic rivet for reuse.

6. Remove the three screws **E** attaching the front panel assembly at the bottom of the body.
7. Release the two joints **a** on the lower left and right sides of the front panel assembly using a screwdriver, and remove the front panel assembly toward the front.

REFERENCE: Front panel need to be tilt a little bit as release from bottom chassis.

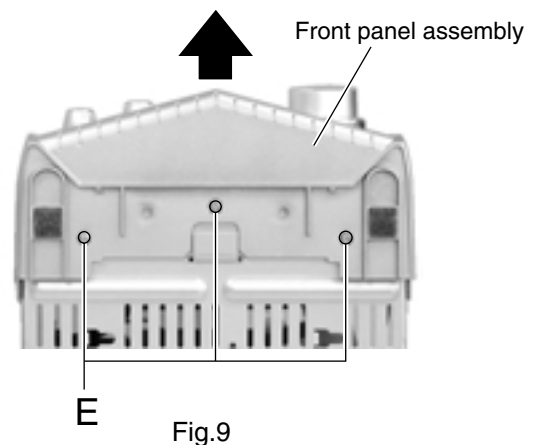
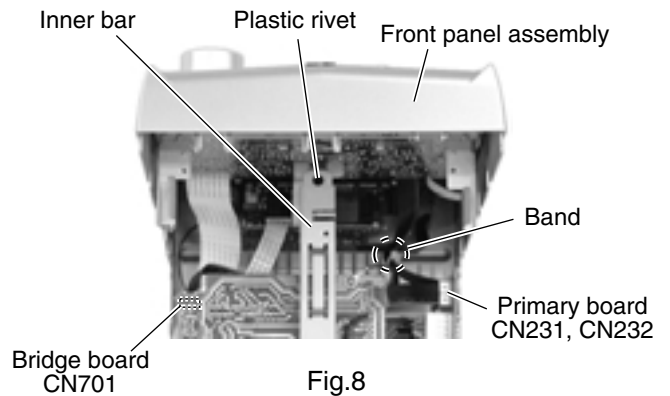
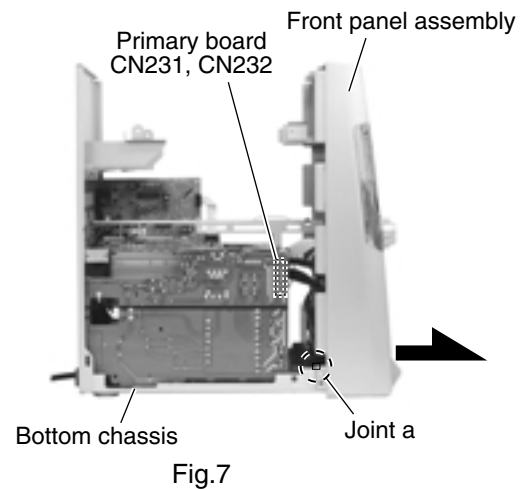
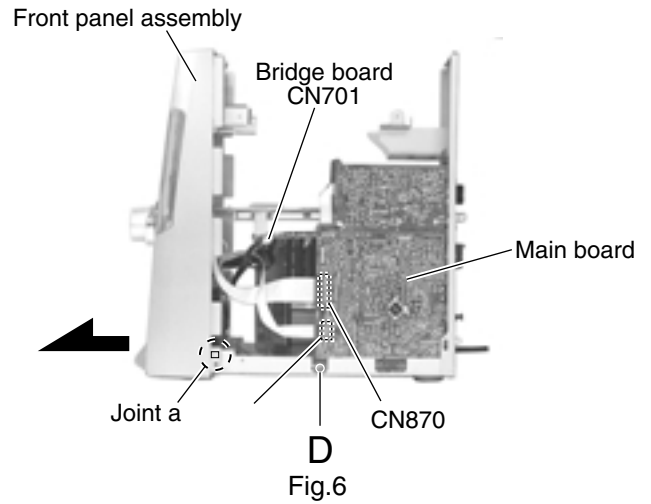

■ Removing the antenna board

(See Fig.10, 11)

- Prior to performing the following procedure, remove the metal cover.

REFERENCE: There is no need to remove the CD changer mechanism assembly.

1. Disconnect the card wire from connector CN1 on the antenna board on the right side of the body.
2. Remove the band attaching the antenna board.
3. Remove the two screws **F** on the rear panel on the back of the body.

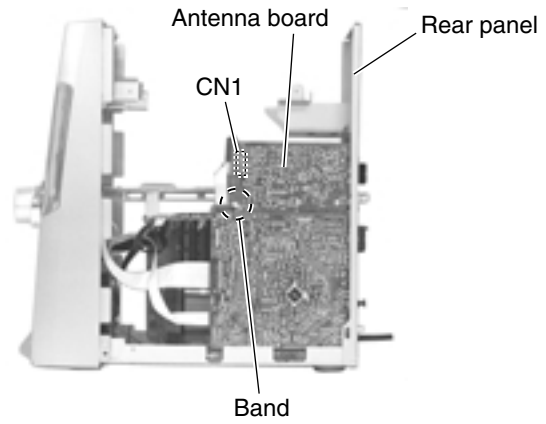

Fig.10

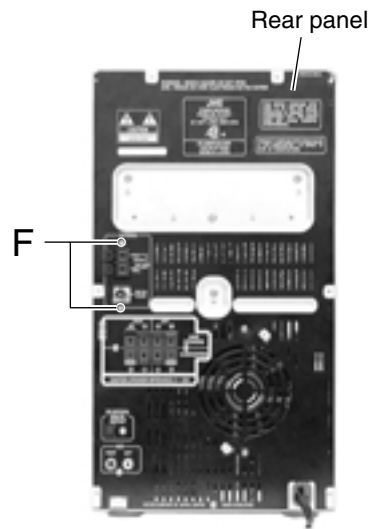

Fig.11

■ Removing the rear panel
(See Fig.12 ~ 17)

• Prior to performing the following procedure, remove the metal cover and the CD changer mechanism assembly.

1. Remove holding board by remove two plastic rivets and then slide out the holding board as shown in fig. 12.
2. Disconnect fan wire from connector CN206.
3. Cut off the tie band that tied fan wire on inner bar.
4. Remove eight screws **F** from rear panel.
5. Detach joint **b** to release rear panel from inner bar.
6. Release joints **c** which on right bottom and left bottom of rear panel. The joint can be release by pull outward the side of rear panel.

REFERENCE: Fan assembly will come off with rear panel.

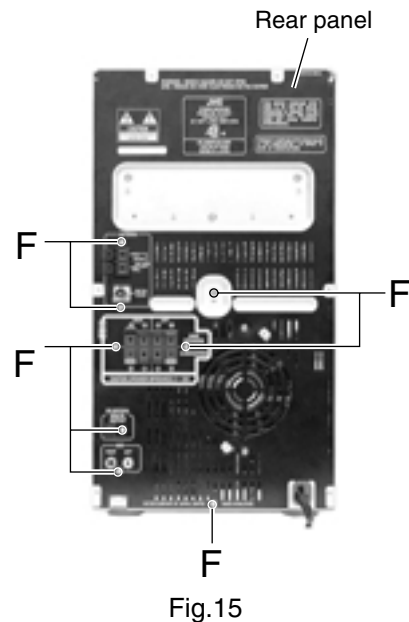
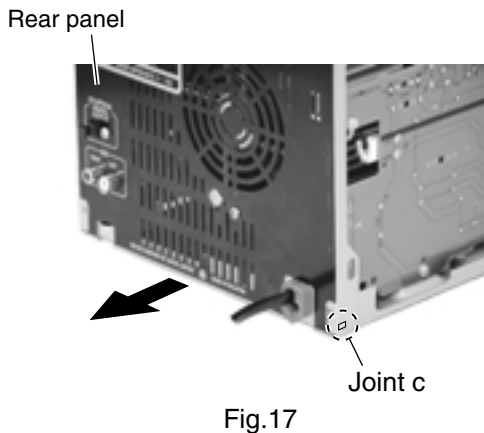
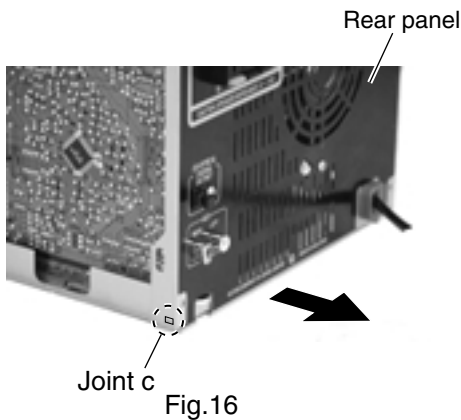
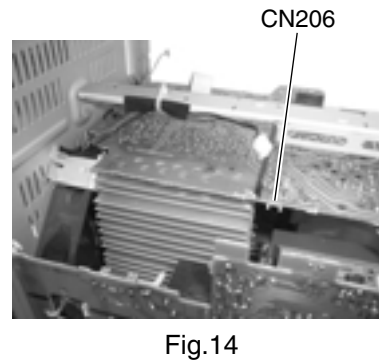
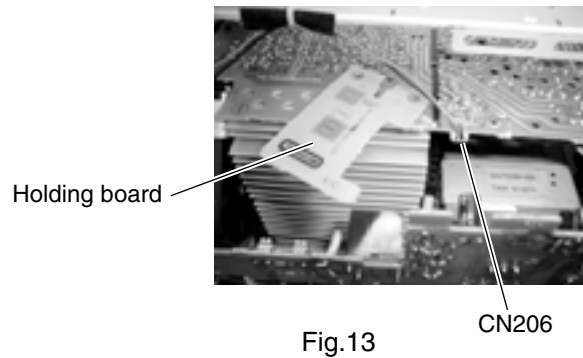
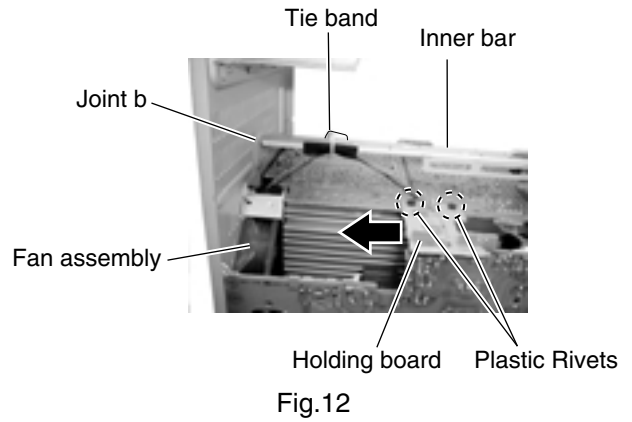

■ Removing the fan assembly (See Fig.18, 19)

- Prior to performing the following procedure, remove the metal cover and the CD changer mechanism assembly and the rear panel.

1. Remove two screws **G** on the rear panel.
2. Rotate fan assembly in clockwise direction to release fan assembly from rear panel (joint **d**).

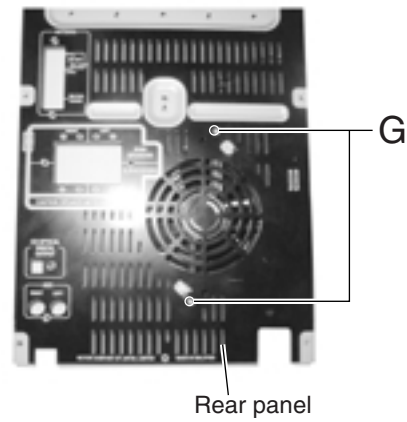

Fig.18

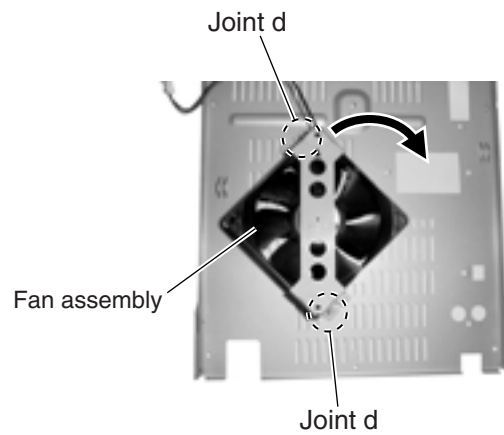

Fig.19

■ Removing the main board (See Fig.20)

- Prior to performing the following procedure, remove the metal cover, the CD changer mechanism assembly, the antenna board and the rear panel.

1. Disconnect the card wire from connector CN44 and CN870 on the main board.
2. Remove the screw **D** attaching the board.
3. Disconnect connector CN217 and CN311 on the main board outward and release from the base chassis (joint **e**) upward.

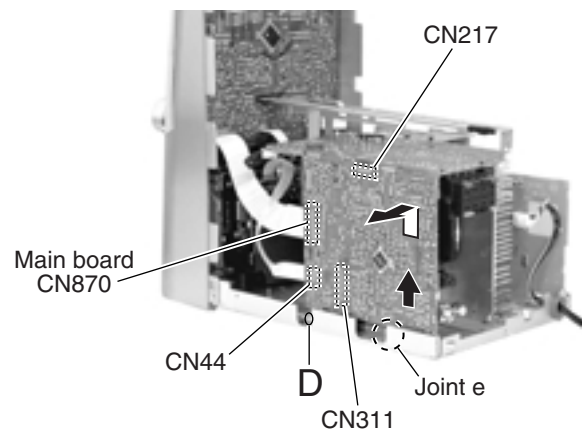

Fig.20

■Removing the bridge board / regulator board / heat sink (See Fig.21 ~ 27)

• Prior to performing the following procedure, remove the metal cover, the CD changer mechanism assembly, the rear panel, the antenna board and main board.

1. Remove the plastic rivet attaching the stay inner bar and remove the screw **H** on the bridge board.
2. Move the inner bar forward and upward to release from the front section (joint **f**) and from the bridge board (two joints **h**) respectively.
3. Remove the two plastic rivets setting the holding board fixing the bridge board and the primary board. Move the bracket board in the direction of the arrow.
4. Disconnect the wire from connector CN212, CN213 and CN214 on the primary board respectively and remove the band attaching the wires.
5. Disconnect the wire from connector CN701 on the bridge board.

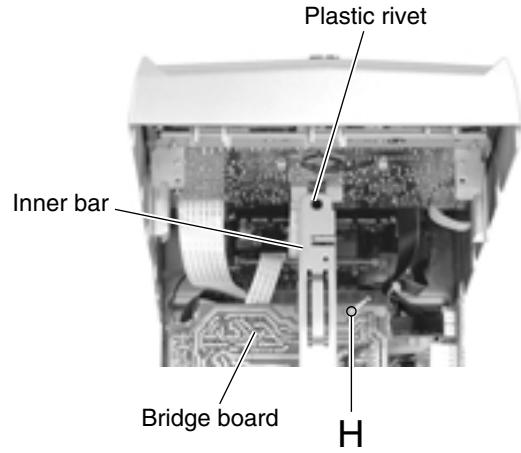

Fig.21

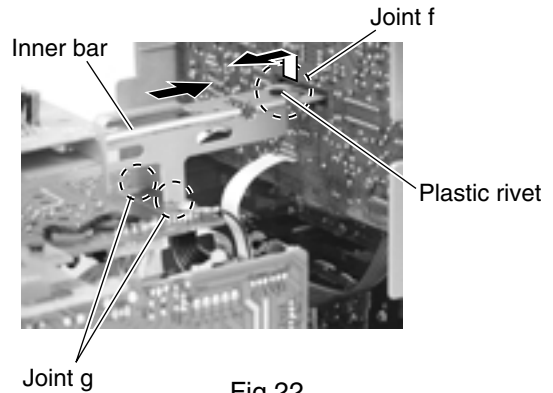

Fig.22

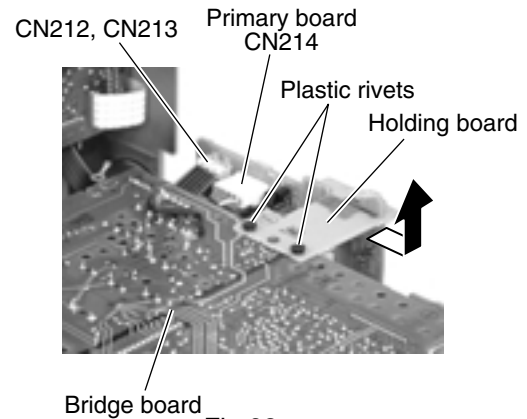

Fig.23

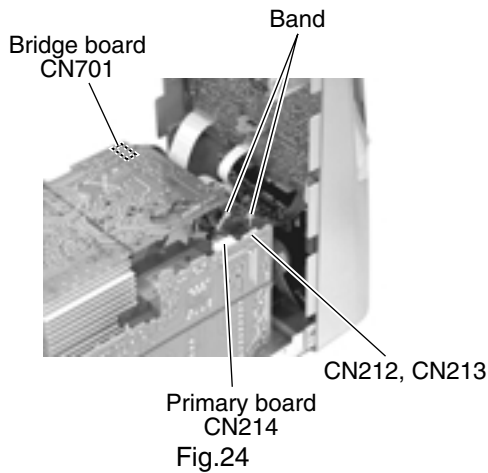

Fig.24

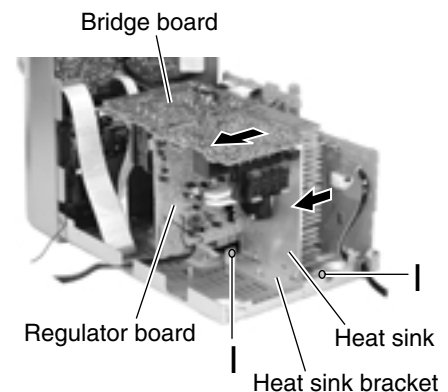
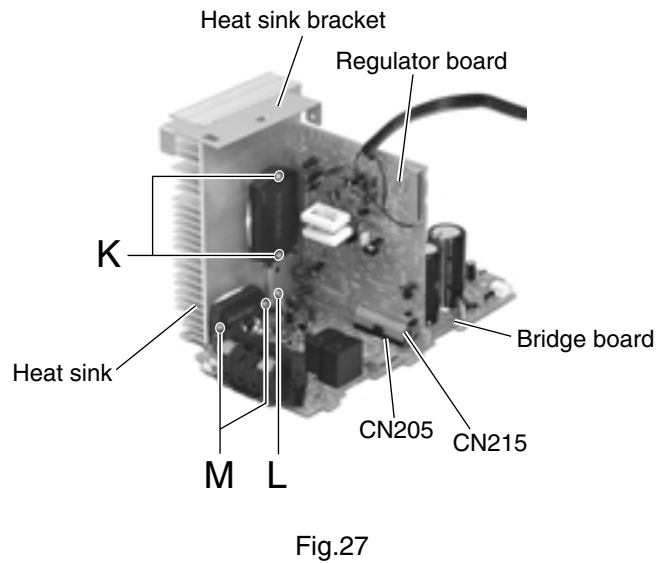
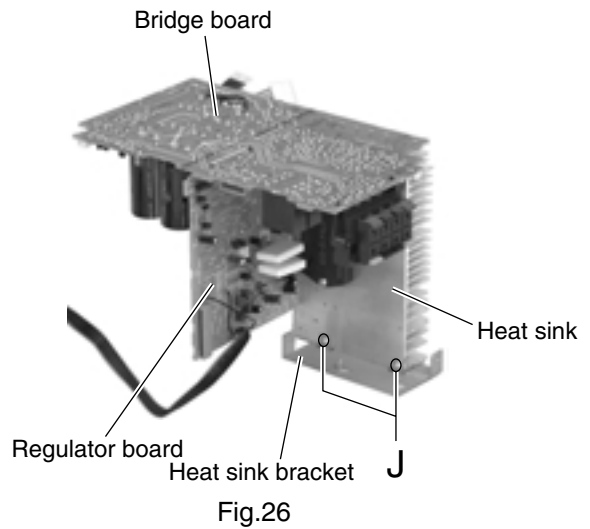

Fig.25

6. Remove the two screws **I** attaching the heat sink bracket and move the heat sink in the direction of the arrow to release from the base chassis (two joints i). The bridge board and the regulator board come off with the heat sink.
7. Remove the two screws **J** attaching the heat sink bracket.
8. Remove the two screws **M**, detach bridge board from regulator board by disconnect connector CN205.
9. Remove the screws **K** and **L** to detach regulator board from heat sink.

CAUTION: As assembly back the regulator board and bridge board to heat sink. Regulator board **MUST** be assembly to heat sink first and screw **K** and **L** **MUST** be screwed before bridge board attach to regulator board.



■ Removing the power transformer assembly (See Fig.28, 29)

- Prior to performing the following procedure, remove the metal cover, the CD changer mechanism assembly, the rear panel, the main board and the bridge board / regulator board.

1. Remove the screw **N** attaching the primary board.
2. Disconnect the wire from connector CN231 and CN232 on the primary board.
3. Remove the four screws **O** attaching the power transformer assembly.
4. Cut the tie band and detach power cord from primary board.

REFERENCE: When disconnecting the power cord from connector CN250 on the primary board, remove the fixing band.

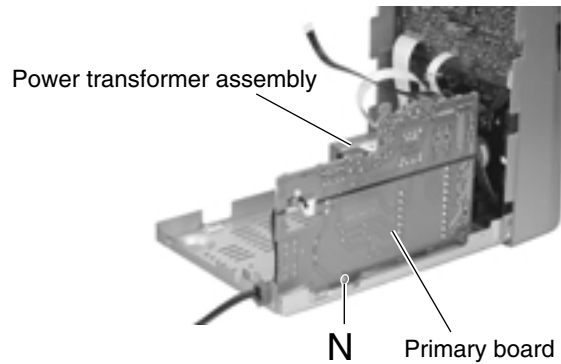

Fig.28

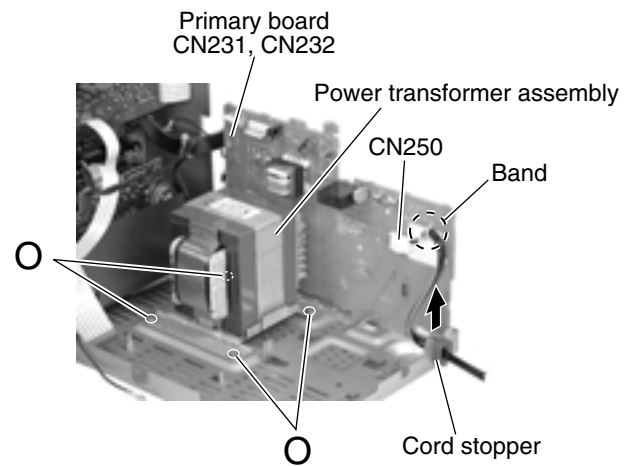

Fig.29

<Front panel assembly>

- Prior to performing the following procedure, remove the metal cover, the CD changer mechanism assembly and the front panel assembly.

■ Removing the cassette mechanism assembly (See Fig.30)

1. Disconnect the card wire from connector CN33 on the head amplifier & mechanism control board.
2. Remove the two screws **P**, and the screw **Q** attaching the cassette mechanism assembly.

■ Removing the headphone board (See Fig.30)

1. Remove the screw **Q** attaching the wire extending from the headphone board.
2. Remove the screw **R** and pull out the headphone board backward.

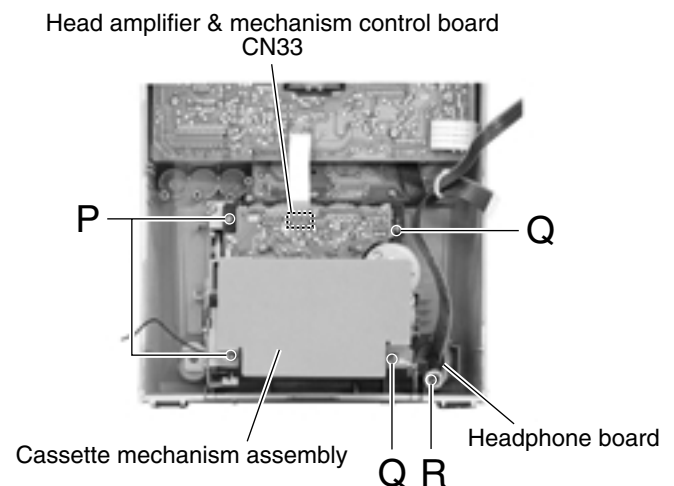
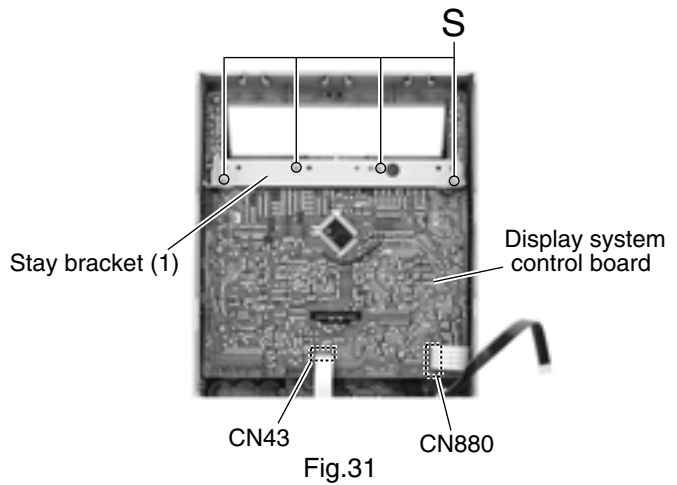

Fig.30

■ **Removing the display system control board**
(See Fig.31, 32)

1. Remove the four screws **S** attaching the stay bracket (1).
2. Disconnect the card wire from connector CN43 and CN880 on the display system control board.

Remove the ten screws **T** attaching the display system control board.



■ **Removing the bottom board**
(See Fig.33 ~ 35)

• Prior to performing the following procedure, remove the display system control board.

1. Pull out preset knob, sound mode knob on the front panel toward the front.
2. Remove the nut at volume knob encoder from front panel.
3. Remove the four screws **U** attaching the stay bracket (2).
4. Remove the eight screws **V** attaching the bottom board.

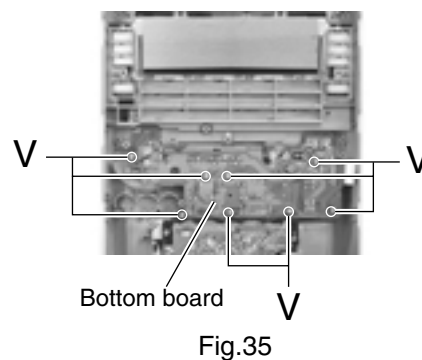
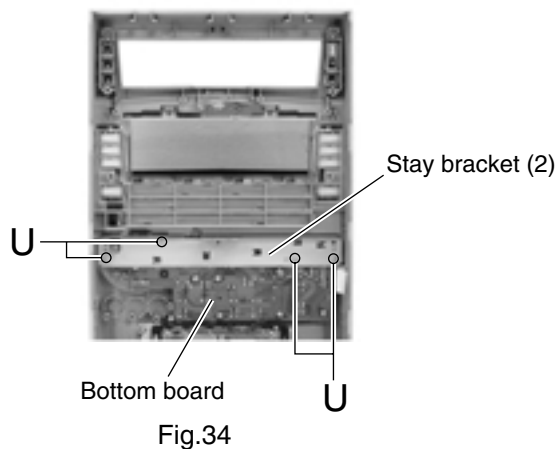
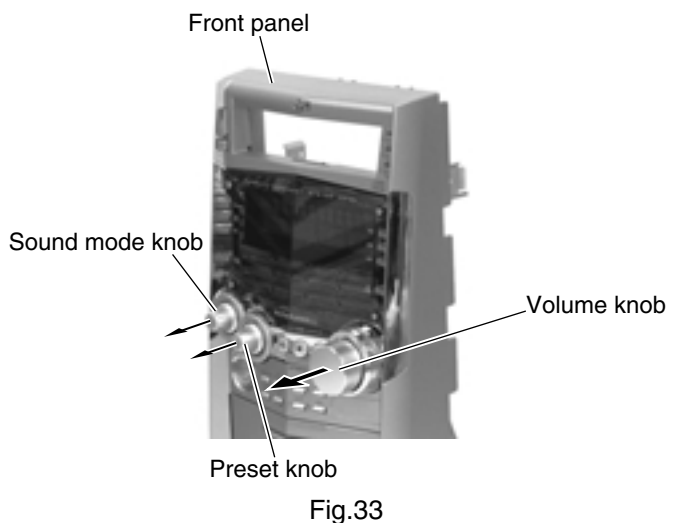
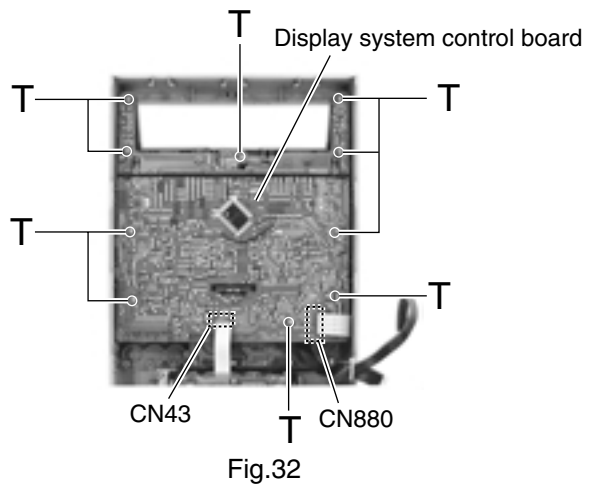

«CD Changer Mechanism Type:VC3 Section»

■ Removing the CD Servo control board (See Fig.1)

- 1.Remove the metal cover.
- 2.Remove the CD changer mechanism assembly.
- 3.From bottom side the CD changer mechanism assembly, remove the four screws **A** retaining the CD servo control board.
- 4.Absorb the four soldered positions "a" of the right and left motors with a soldering absorber.
- 5.Pull out the earth wire on the CD changer mechanism assembly.
- 6.Disconnect the connector CN854 on the CD servo control board.
- 7.Disconnect the card wire CN601 and the connector CN801 on the CD servo control board.

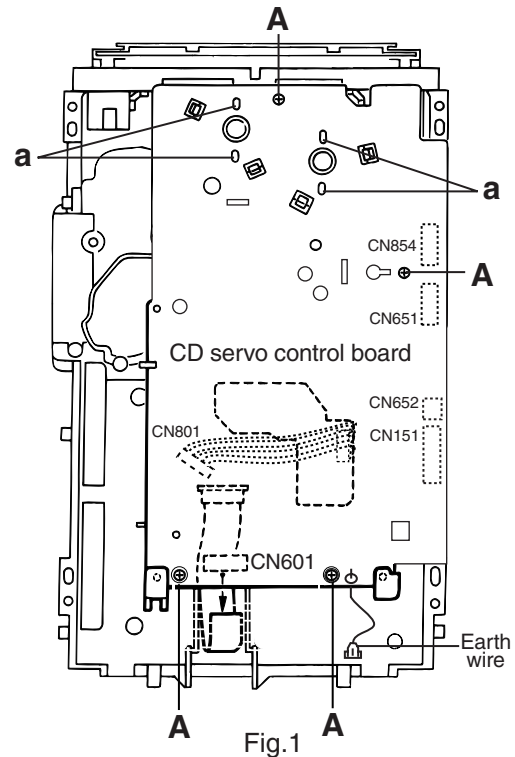

■ Removing the CD tray assembly (See Fig.2~4)

1. Remove the front panel assembly. (See Fig.2~4)
2. Remove the CD changer mechanism assembly.
3. Remove the CD Servo control board.
4. Remove the screw **B'** retaining the lod stopper. (See Fig.3).
5. From the T.bracket section "b" and clamber base section "c", remove both of the edges fixing the rod (See Fig.2 and 3).
6. Remove the screw **B** retaining the disc stopper (See Fig.3).
7. Remove the three screws **C** retaining the T.bracket (See Fig.3).
8. Remove the screw **D** retaining the clamber assembly (See Fig.3).
9. From the left side face of the chassis assembly, remove the one screw **E** retaining both of the return spring and lock lever (See Fig. 4).
10. By removing the pawl at the section "d" fixing the return spring, dismount the return spring (See Fig.4).
11. Remove the three lock levers (See Fig.4).

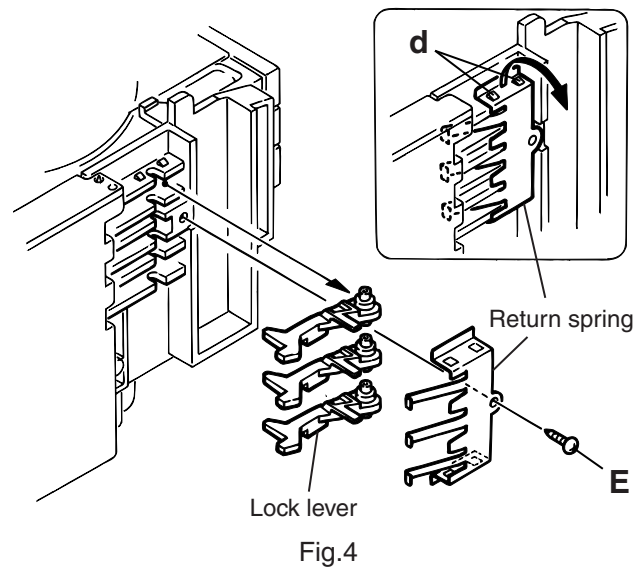
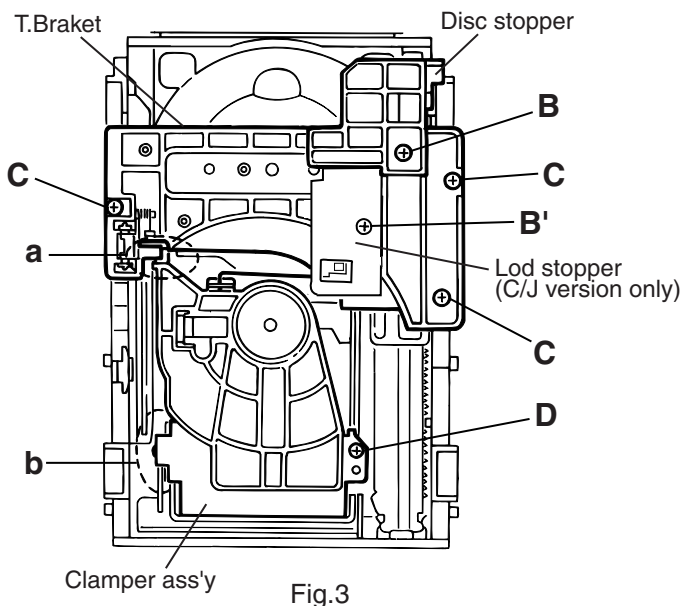
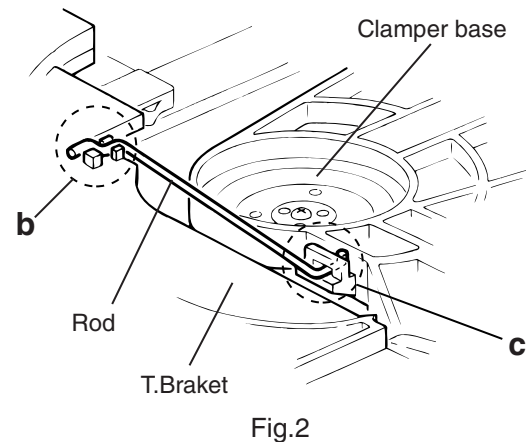

11. Check whether the lifter unit stopper has been caught into the hole at the section "e" of CD tray assembly as shown in Fig.5.
12. Make sure that the driver unit elevator is positioned as shown in Fig.6 from to the second or fifth hole on the left side face of the CD changer mechanism assembly.

[Caution] In case the driver unit elevator is not at above position, set the elevator to the position as shown in Fig.7 by manually turning the pulley gear as shown in Fig.8.

13. Manually turn the motor pulley in the clockwise direction until the lifter unit stopper is lowered from the section "e" of CD tray assembly(See Fig.8).
14. Pull out all of the three stages of CD tray assembly in the arrow direction "f" until these stages stop
(See Fig.6).
15. At the position where the CD tray assembly has stopped, pull out the CD tray assembly while pressing the two pawls "g and g' " on the back side of CD tray assembly(See Fig.9). In this case, it is easy to pull out the assembly when it is pulled out first from the stage CD tray assembly.

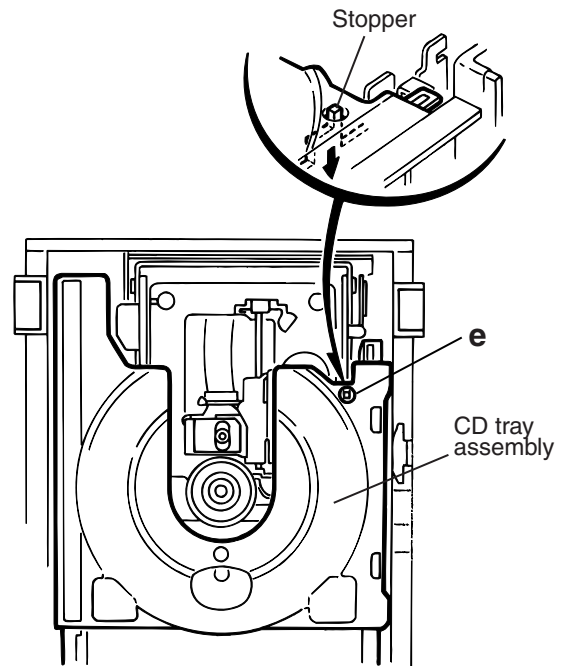

Fig.5

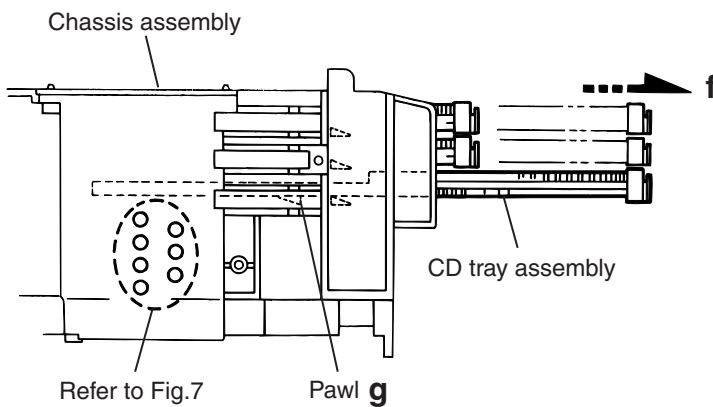

Fig.6

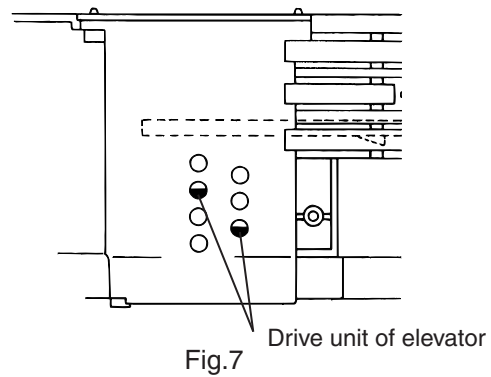

Fig.7

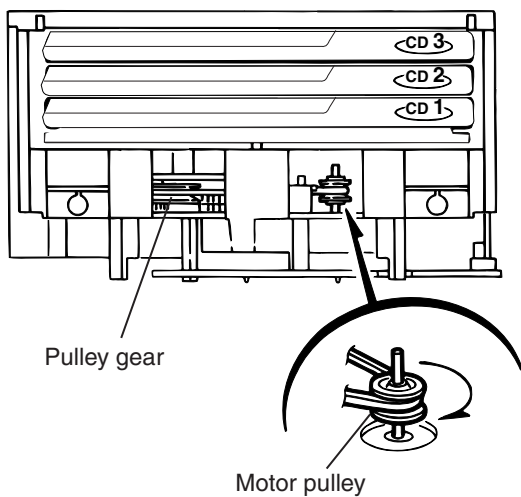
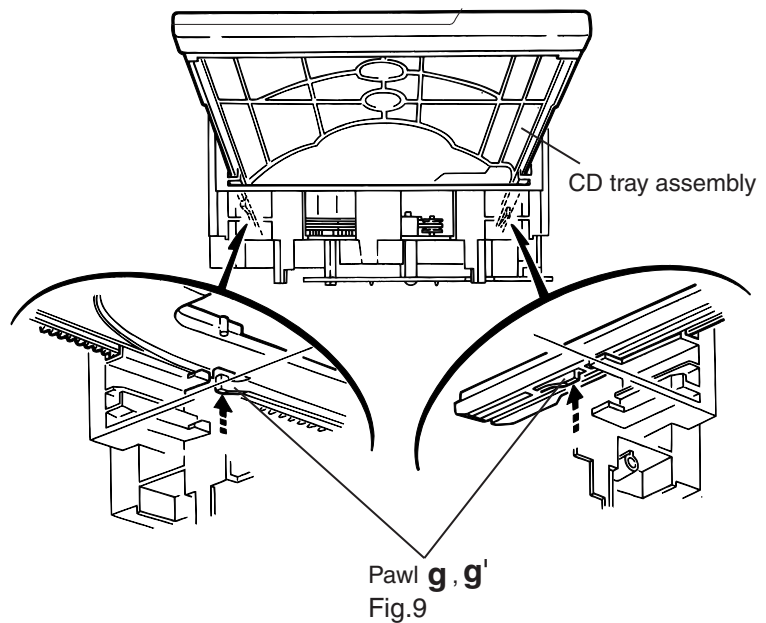

Fig.8



Pawl g, g'
Fig.9

Removing the CD loading mechanism assembly(See Fig.10)

1. While turning the cams R1 and R2 assembly in the arrow direction "h", align the shaft "i" of the CD loading mechanism assembly to the position shown in Fig.10.
2. Remove the four screws **F** retaining the CD loading mechanism assembly.

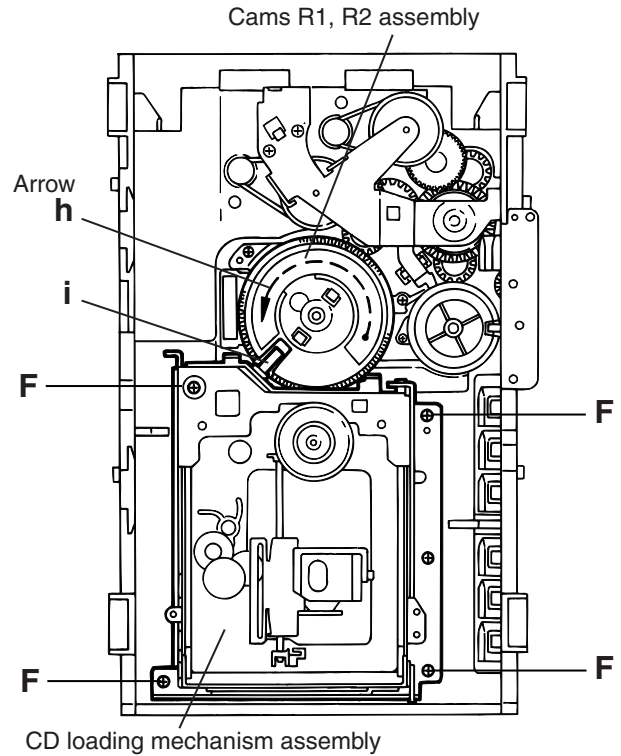

Fig.10

Removing the CD traverse mechanism (See Fig.11 and 12)

1. For dismantling only the CD traverse mechanism without removing the CD loading mechanism assembly, align the shaft "j" of the CD loading mechanism assembly to the position shown Fig.11 while turning the cam R1 and R2 assembly in the arrow direction "k".
2. By raising the CD loading mechanism assembly in the arrow direction "l", remove the assembly from the lifter unit

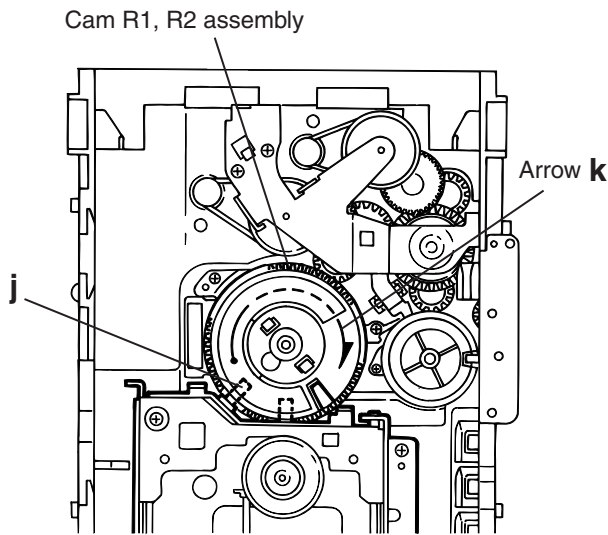

Fig.11

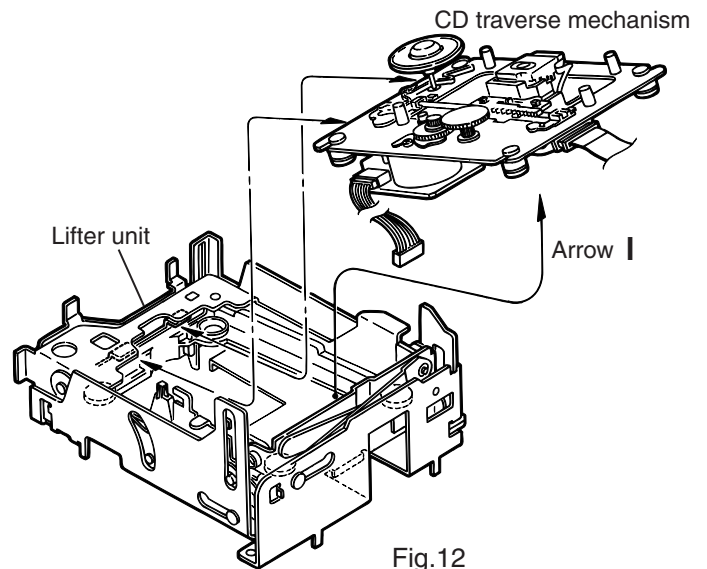

Fig.12

Removing the CD pick unit (See Fig.13)

1. Move the cam gear in the arrow direction "m". Then, the CD pickup unit will be moved in the arrow direction "n".
2. According to the above step, shift the CD pickup unit to the center position.
3. While pressing the stopper retaining the shaft in the arrow direction "o", pull out the shaft in the arrow direction "p".
4. After dismantling the shaft from the CD pickup unit, remove the CD pickup unit

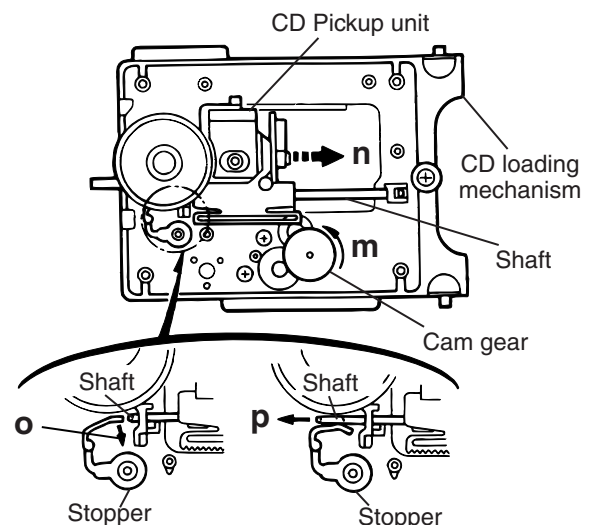

Fig.13

■ **Removing the tray select switch board**
(See Fig.14)

1. Remove the two screws **G** retaining the tray select switch board.
2. Disconnect the tray select switch board from connector CN804 on the CD servo control board.

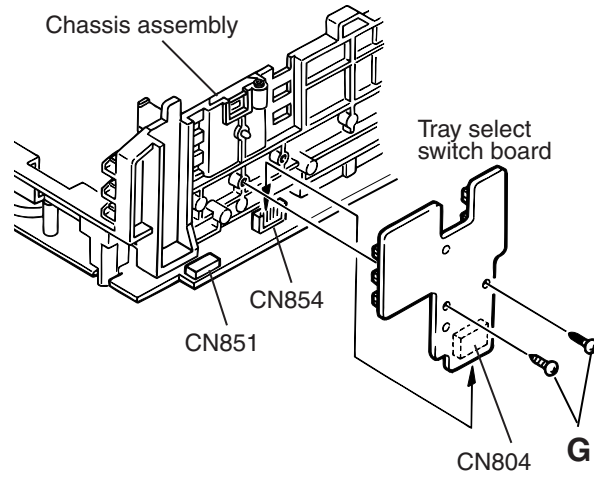

Fig.14

■ **Removing the cam unit**
(See Fig.15 ~17)

1. Remove the CD loading mechanism assembly.
2. While turning the cam gear "q", align the Paul "r" position of the drive unit to the notch position(Fig.16) on the cam gear "q".
3. Pull out the drive unit and cylinder gear(See Fig.17).
4. While turning the cam gear "q", align the Paul "s" position of the select lever to the notch position(Fig.18) on the cam gear "q".
5. Remove the four screws **H** retaining the cam unit(cam gear "q" and cams R1/R2 assembly)(See Fig.18).

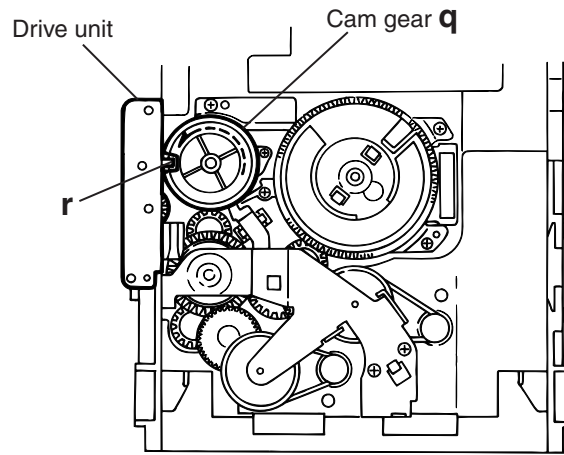

Fig.15

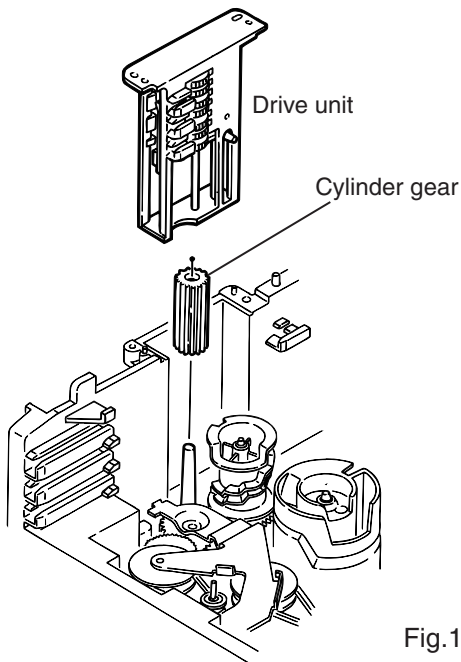

Fig.16

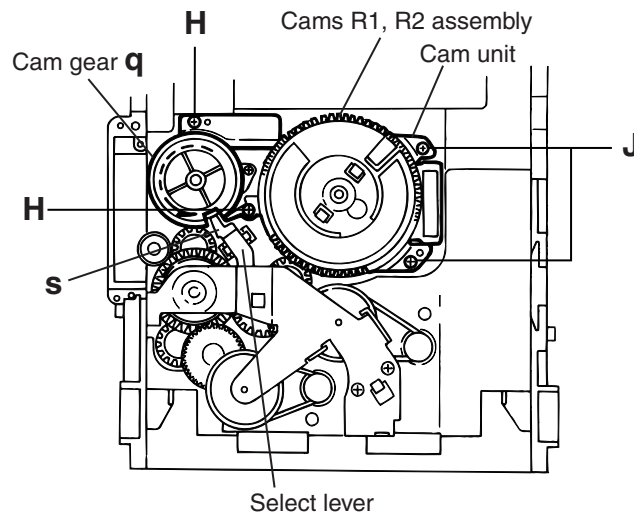

Fig.17

**■ Removing the actuator motor and belt
(See Fig.18~21)**

1. Remove the two screws **I** retaining the gear bracket
(See Fig.18).
2. While pressing the pawl **"t"** fixing the gear bracket in the arrow direction, remove the gear bracket
(See Fig.18).
3. From the notch **"u"** section on the chassis assembly fixing the edge of gear bracket, remove and take out the gear bracket(See Fig. 19).
4. Remove the belts respectively from the right and left actuator motor pulleys and pulley gears(See Fig. 18).
5. After turning over the chassis assembly, remove the actuator motor while spreading the four pawls **"v"** fixing the right and left actuator motors in the arrow direction(See Fig. 20).

[Note] When the chassis assembly is turned over under the conditions wherein the gear bracket and belt have been removed, then the pulley gear as well as the gear, etc. constituting the gear unit can possibly be separated to pieces. In such a case, assemble these parts by referring to the assembly and configuration diagram in Fig. 21.

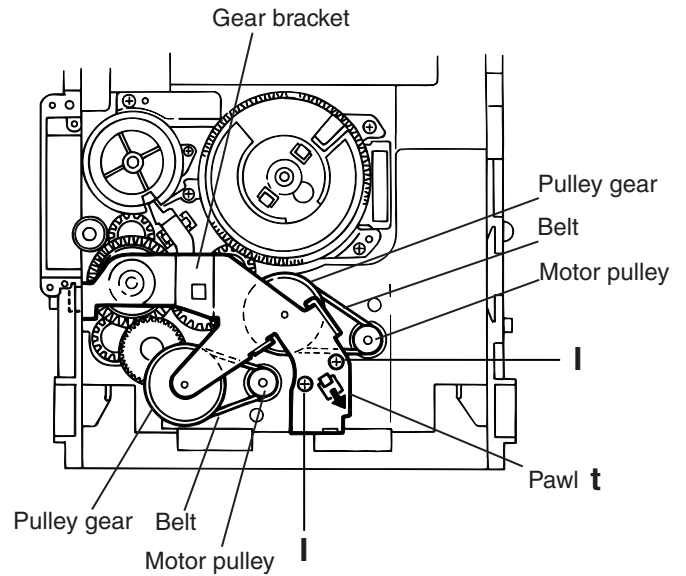

Fig.18

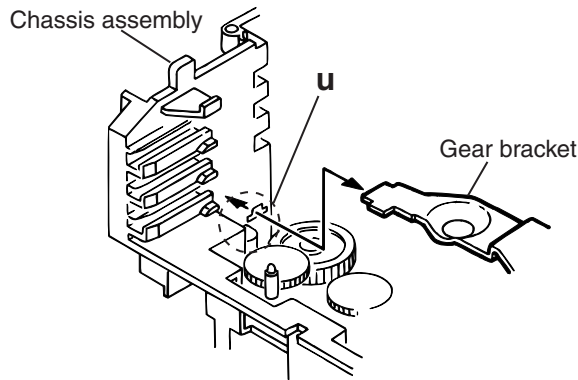

Fig.19

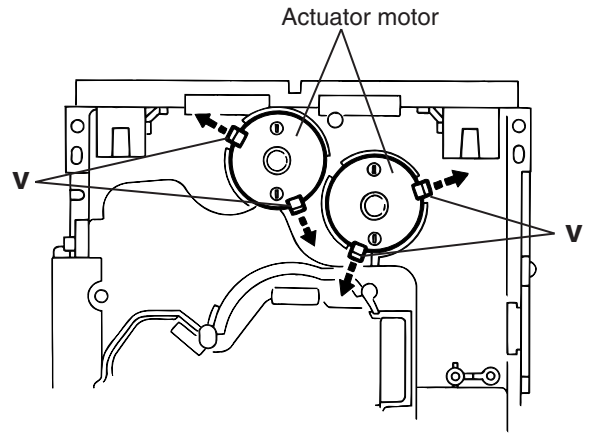

Fig.20

Assembly and Configuration Diagram

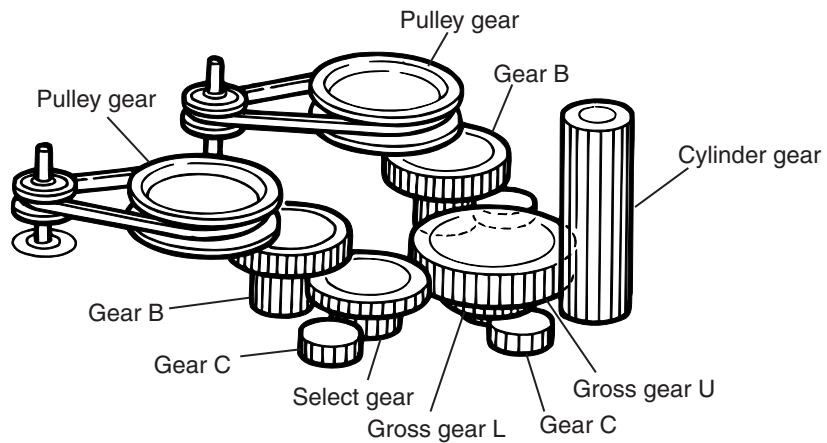

Fig.21

■ Removing the cams R1/R2 assembly and cam gear q(See Fig.22)

1. Remove the slit washer fixing the cams R1 and R2 assembly.
2. By removing the two pawls "w" fixing the cam R1, separate R2 from R1.
3. Remove the slit washer fixing the cam gear "q".
4. Pull out the cam gear "q" from the C.G. base assembly.

■ Removing the C.G. base assembly (See Fig.22 and 23)

Remove the three screws **J** retaining the C.G. base assembly.

[Caution] To reassemble the cylinder gear, etc.with the cam unit (cam gear and cans R1/R2 assembly), gear unit and drive unit, align the position of the pawl "x" on the drive unit to that of the notch on the cam gear "q". Then, make sure that the gear unit is engaged by turning the cam gear "q" (See Fig. 24).

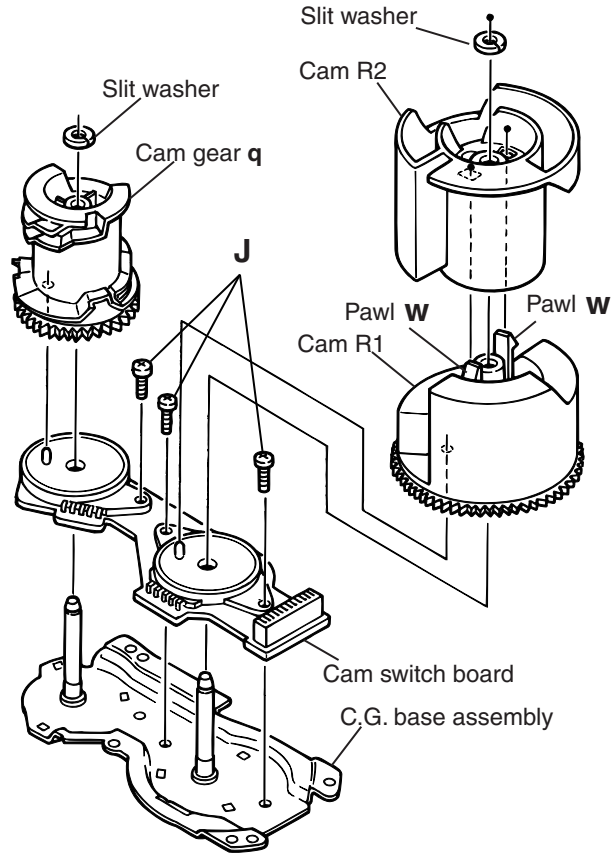

Fig.22

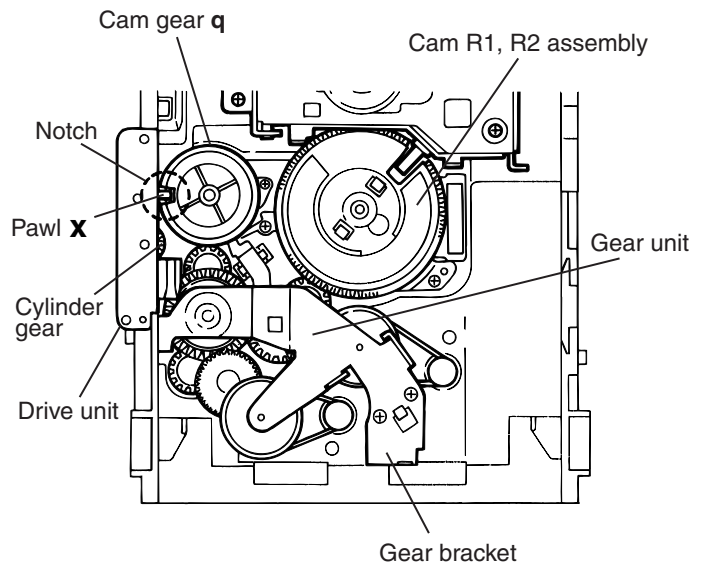

Fig.23

<Cassette mechanism section>

■ Removing the playback / recording & eraser head (See Fig. 1 ~ 3)

1. While shifting the trigger arms seen on the right side of the head mount in the arrow direction, turn the flywheel R in counterclockwise direction until the head mount has gone out with a click (See Fig. 1).
2. When the flywheel (R) is rotated in counterclockwise direction, the playback / recording & eraser head will be turned in counterclockwise direction from the position in Fig. 2 to that in Fig. 3.
3. At this position, disconnect the flexible P.C. board (outgoing from the playback / recording & eraser head) from the connector CN31 on the head amplifier & mechanism control P.C. board.
4. Remove the flexible P.C. board from the chassis base.
5. Remove the spring **a** from behind the playback / recording & eraser head.
6. Loosen the reversing azimuth screw retaining the playback / recording & eraser head.
7. Take out the playback / recording & eraser head from the front of the head mount.
8. The playback / recording & eraser head should also be removed similarly according to steps 1 to 7 above.

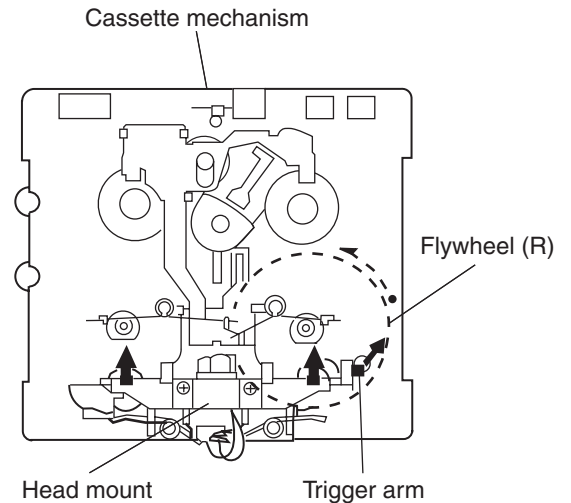

Fig. 1

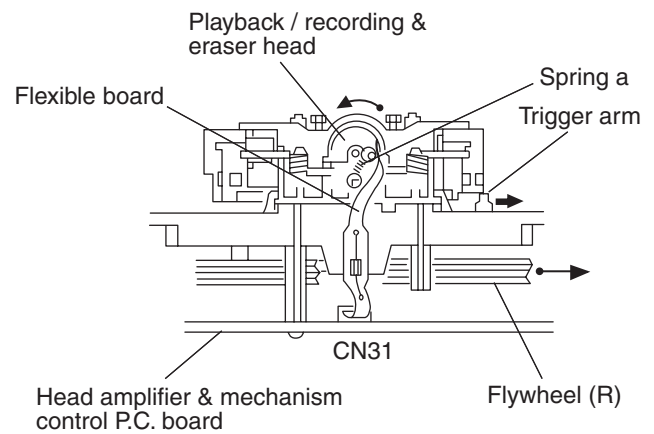

Fig. 2

■ Reassembling the playback / recording & eraser head (See Fig.2, 3)

1. Reassemble the playback head from the front of the head mount to the position as shown in Fig. 3.
2. Fix the reversing azimuth screw.
3. Set the spring **1** from behind the playback / recording & eraser head.
4. Attach the flexible P.C. board to the chassis base, as shown in Fig. 3.
5. The playback / recording & eraser head should also be reassembled similarly to step 1 to 4 above.

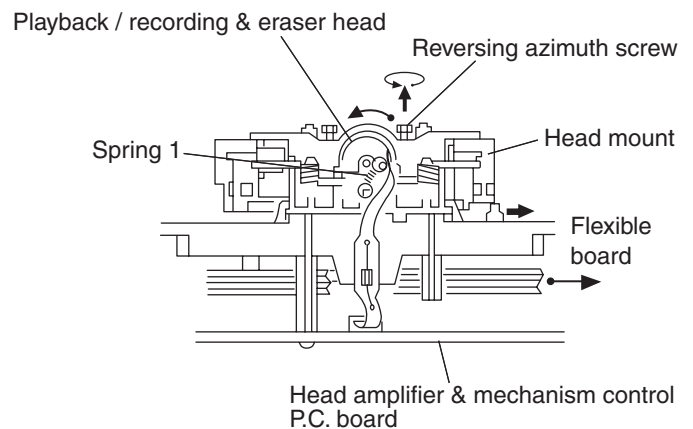

Fig. 3

Removing the head amplifier & mechanism control board
(See Fig. 4)

1. Remove the cassette mechanism assembly.
2. After turning over the cassette mechanism assembly, remove the three screws **A** retaining the head amplifier & mechanism control board.
3. Disconnect the connector CN32 on the board including the connector CN1 on the reel pulse P.C. board.
4. When necessary, remove the 4 pin parallel wire soldered to the main motor.

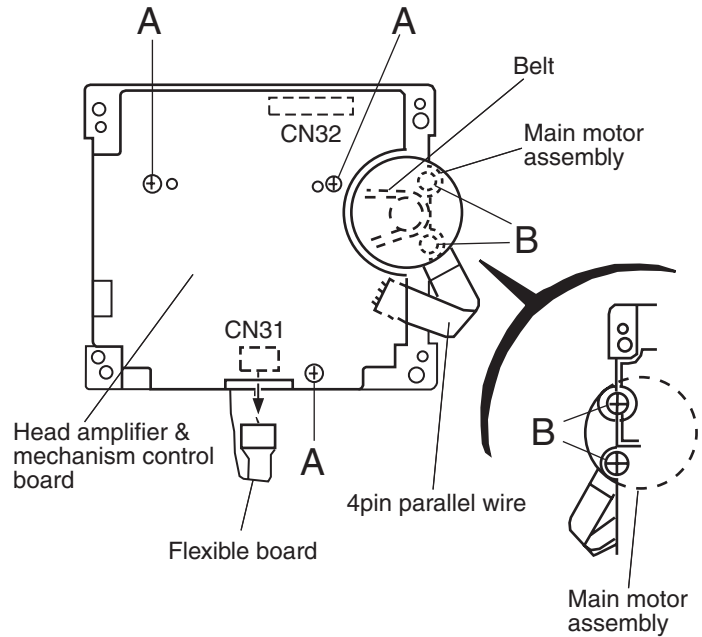

Fig. 4

Removing the main motor assembly
(See Fig.4 ~ 6)

1. Remove the two screws **B** retaining the main motor assembly (See Fig. 4 and 4a).
2. While raising the main motor, remove the capstan belt from the motor pulley (See Fig. 4a).

CAUTION: Be sure to handle the capstan belt so carefully that this belt will not be stained by grease and other foreign matter. Moreover, this belt should be hung while referring to the capstan belt hanging method in Fig. 5 and 6.

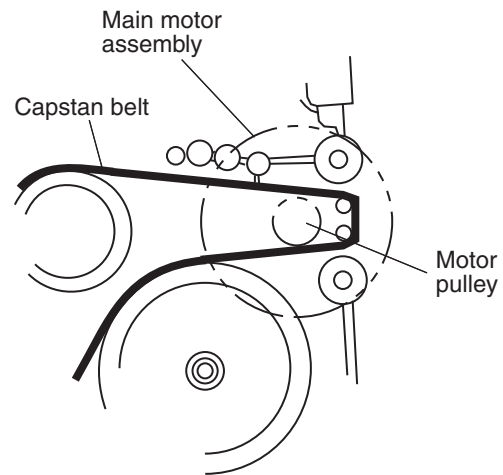

Fig. 4a

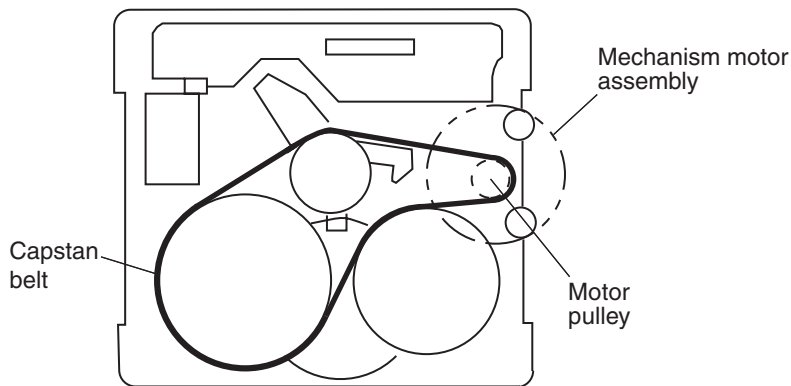

Fig. 5

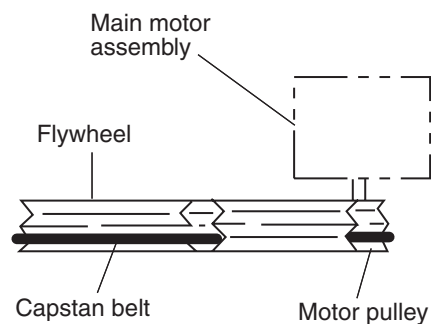

Fig. 6

■ Removing the flywheel (See Fig. 7, 8)

1. Remove the head amplifier & mechanism control P.C. board.
2. Remove the main motor assembly.
3. After turning over the cassette mechanism, remove the two slit washers and fixing the capstan shafts R and L, and pull out the flywheel (R) and (L) respectively from behind the cassette mechanism.

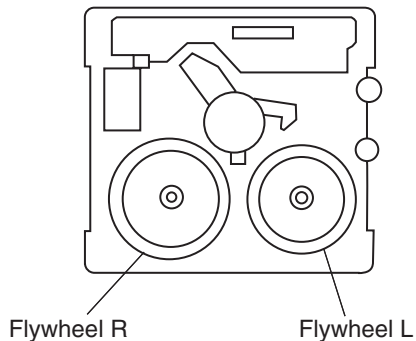

Fig. 8

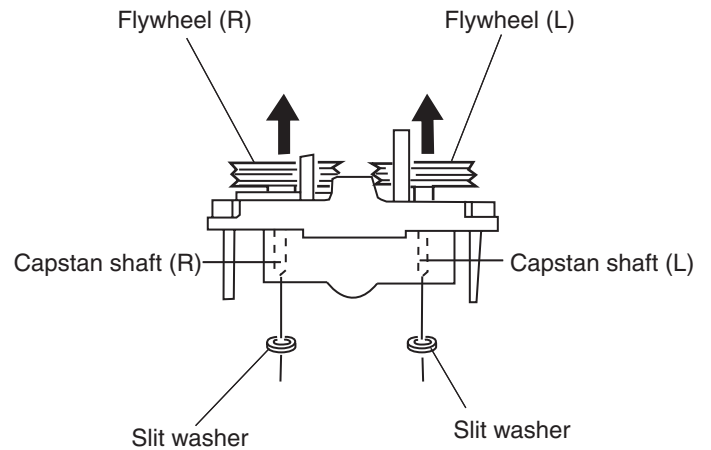

Fig. 7

■ Removing the reel pulse P.C. board and solenoid (See Fig. 9)

1. Remove the five pawls a to e retaining the reel pulse board.
2. From the surface of the reel pulse board parts, remove the two pawls f and g retaining the solenoid.

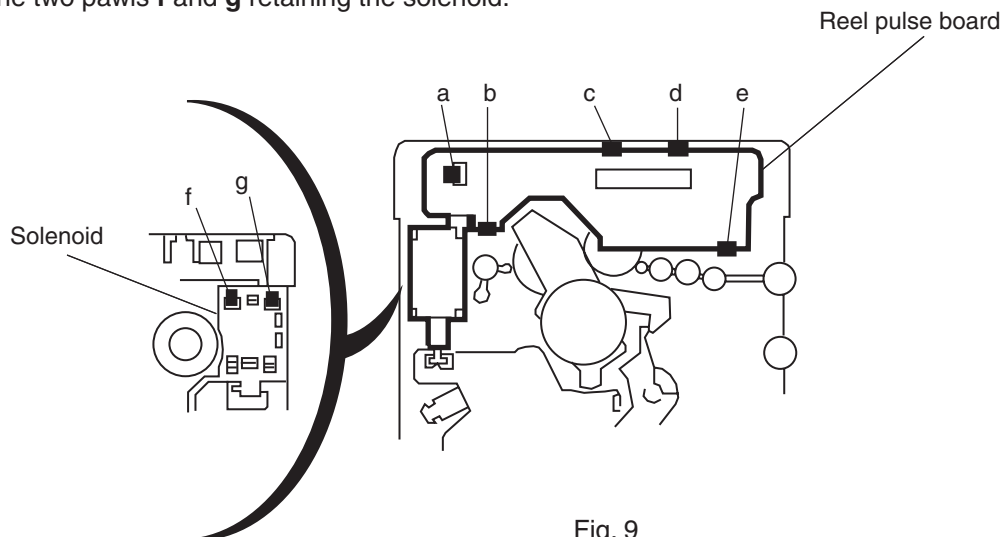

Fig. 9

■ Tape Recorder Section

Items	Measurement conditions	Measurement method	Standard Values	Adjusting positions
Confirmation of head angle	Test tape : VTT703L (8kHz) Measurement output terminal : Speaker terminal Speaker R (Load resistance: 4Ω) : Headphone terminal	1 Playback the test tape VTT703L (8kHz) 2 With the recording & playback mechanism, adjust the head azimuth screw so that the forward and reverse output levels become maximum. After adjustment, lock the head azimuth at least by half turn. 3 In either case, this adjustment should be performed in both the forward and reverse directions with the head azimuth screw.	Maximum output	Adjust the head azimuth screw only when the head has been changed.
Confirmation of tape speed	Test tape : VT712 (3kHz) Measurement output terminal : Headphone terminal	Adjust VR37 so that the frequency counter reading becomes 2,940~3,090Hz \pm when playing back the test tape VT712 (3kHz) with playback and recording mechanism after ending forward winding of the tape.	Tape speed of deck : 2,940 ~ 3,090Hz	VR37

■ Reference Values for Confirmation Items

Items	Measurement conditions	Measurement method	Standard Values	Adjusting positions
Difference between the forward and reverse speed	Test tape : VT712 (3kHz) Measurement output terminal : Speaker terminal Speaker R (Load resistance: 4 Ω) Measurement output terminal : Headphone	When the test tape VT712 (3kHz) has been played back with the recording and playback mechanism at the beginning of forward winding, the frequency counter reading of the difference between both of the mechanism should be 6.0Hz or less.	6.0Hz or less	Head azimuth screw
Wow & flutter	Test tape : VT712 (3kHz) Measurement output terminal : Headphone terminal	When the test tape VT712 (3kHz) has been played back with the recording and playback mechanism at the beginning of forward winding, the frequency counter reading of wow & flutter should be 0.25% or less (WRMS).	0.25% or less (WRMS)	

■ Electrical Performance

Items	Measurement conditions	Measurement method	Standard Values	Adjusting positions
Adjustment of recording bias current (Reference Value)	<ul style="list-style-type: none"> ▪ Mode: Forward or reverse mode ▪ Recording mode ▪ Test tape : AC-514 to TYPE II and AC-225 to TYPE I Measurement output terminal : Both recording and headphone terminals	<ol style="list-style-type: none"> 1 With the recording and playback mechanism, load the test tapes (AC-514 to TYPE II and AC-225 to TYPE I), and set the mechanism to the recording and pausing condition in advance. 2 After connecting 100 Ω in series to the recorder head, measure the bias current with a valve voltmeter at both of the terminals. 3 After resetting the [PAUSE] mode, start recording. At this time, adjust VR31 for Lch and VR32 for Rch so that the recording bias current values become 4.0 μ A (TYPE I) and 4.20 μ A (TYPE II). 	AC-225 : 4.20 μ A AC-514 : 4.0 μ A	VR31
Adjustment of recording and playback frequency characteristics	Reference frequency : 1kHz and 10kHz (REF.: -20dB) Test tape : AC-514 to TYPE II Measurement input terminal : OSC IN	<ol style="list-style-type: none"> 1 With the recording and playback mechanism, load the test tapes (AC-514 to TYPE II), and set the mechanism to the recording and pausing condition in advance. 2 While repetitively inputting the reference frequency signal of 1kHz and 10kHz from OSC IN, record and playback the tape. 3 While recording and playback the test tape in TYPE II, adjust VR31 for Lch and VR32 for Rch so that the output deviation between 1kHz and 10kHz becomes -1dB \pm 2dB. 	Output deviation between 1kHz and 10kHz : -1dB \pm 2dB	VR31

■ Reference Values for Electrical Function Confirmation Items

Items	Measurement conditions	Measurement method	Standard Values	Adjusting positions
Recording bias frequency	Forward or reverse <ul style="list-style-type: none"> ▪ Test tape : TYPE II (AC-514) ▪ Measurement terminal : BIAS TP on P.C. board 	<ol style="list-style-type: none"> 1 While changing over to and from BIAS 1 and 2, confirm that the frequency is changed. 2 With the recording and playback mechanism, load the test tape. (AC-514 to TYPE II), and set the mechanism to the recording and pausing condition in advance. 3 Confirm that the BIAS TP frequency on the P.C. board is 100kHz \pm 6kHz. 	100 kHz \pm 6 kHz	
Eraser current (Reference value)	Forward or reverse <ul style="list-style-type: none"> ▪ Recording mode ▪ Test tape : AC-514 to TYPE II and AC-225 to TYPE I Measurement terminal : Both of the eraser head terminals	<ol style="list-style-type: none"> 1 While recording and playback mechanism, load the test tapes (AC-514 to TYPE II and AC-225 to TYPE I), and set the mechanism to the recording and pausing conditions in advance. 2 After setting to the recording conditions, connect 1W in series to the eraser head on the recording and playback mechanism side, and measure the eraser current from both of the eraser terminals. 	TYPE II : 120 mA TYPE I : 75 mA	

■ Extension code connecting method

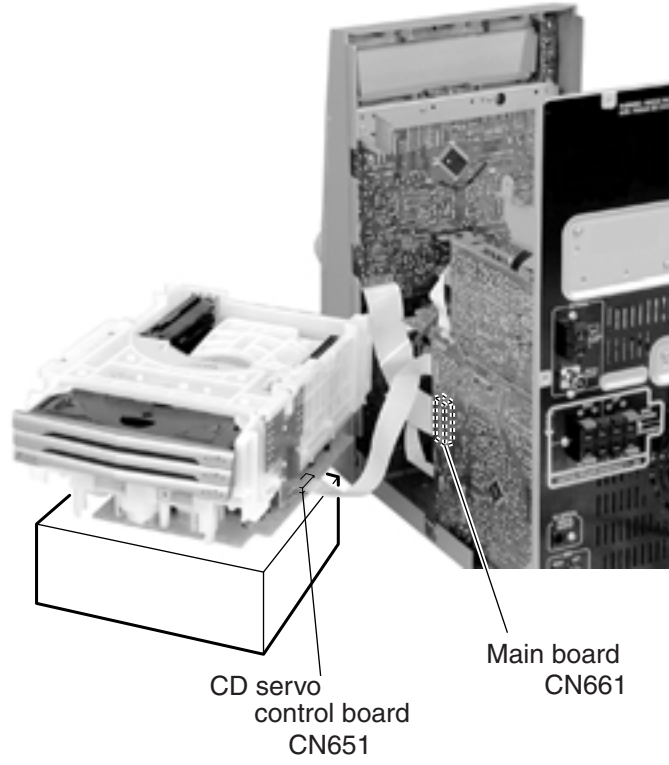

Flow of functional operation until TOC read

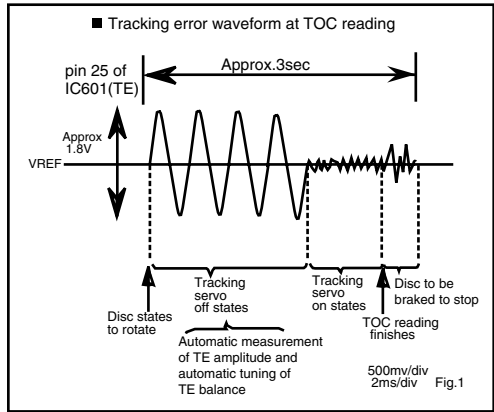
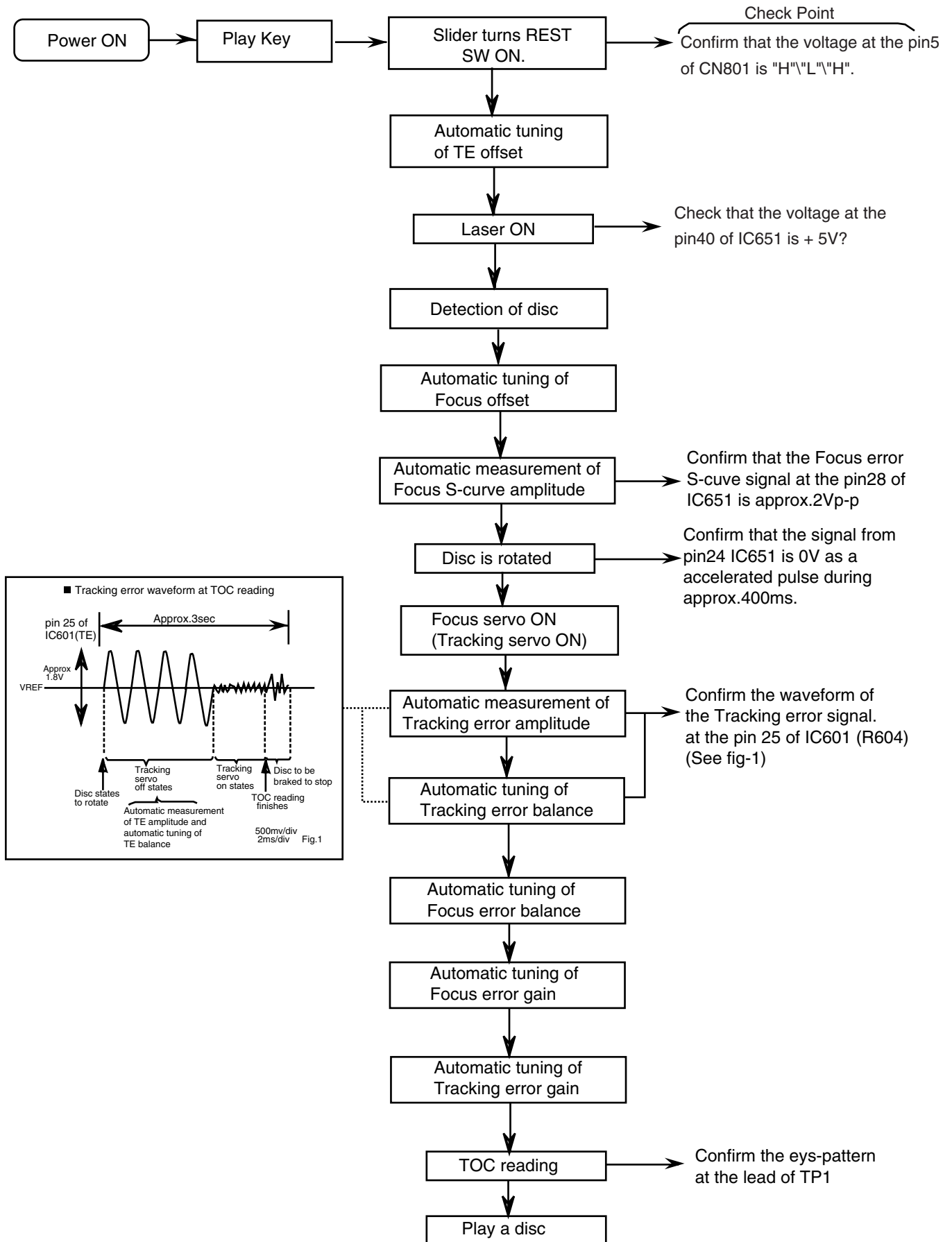

Maintenance of laser pickup

(1) Cleaning the pick up lens

Before you replace the pick up, please try to clean the lens with a alcohol soaked cotton swab.

(2) Life of the laser diode

When the life of the laser diode has expired, the following symptoms will appear.

1. The level of RF output (EFM output : amplitude of eye pattern) will below.

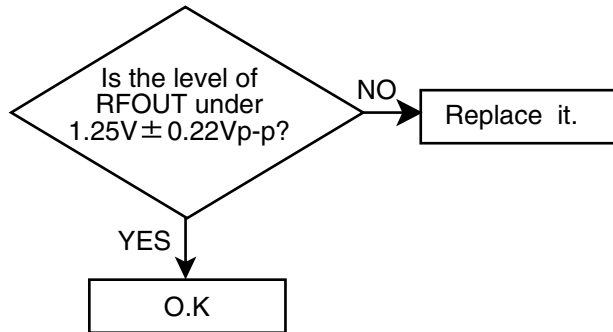

Replacement of laser pickup

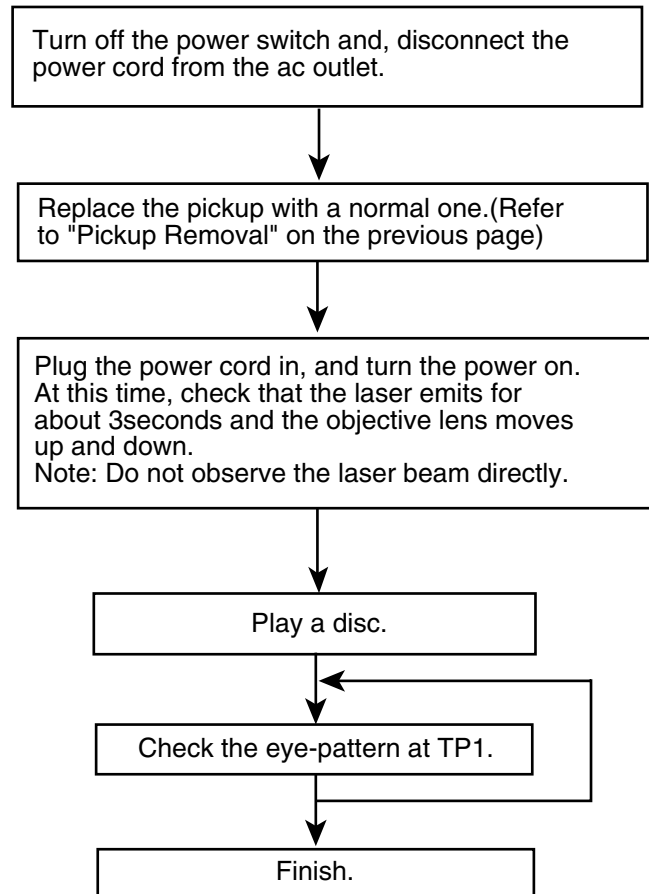

(3) Semi-fixed resistor on the APC PC board

The semi-fixed resistor on the APC printed circuit board which is attached to the pickup is used to adjust the laser power. Since this adjustment should be performed to match the characteristics of the whole optical block, do not touch the semi-fixed resistor.

If the laser power is lower than the specified value, the laser diode is almost worn out, and the laser pickup should be replaced.

If the semi-fixed resistor is adjusted while the pickup is functioning normally, the laser pickup may be damaged due to excessive current.

Description of major ICs

■ BU2092 (IC642) : Port expander

1.Pin Layout

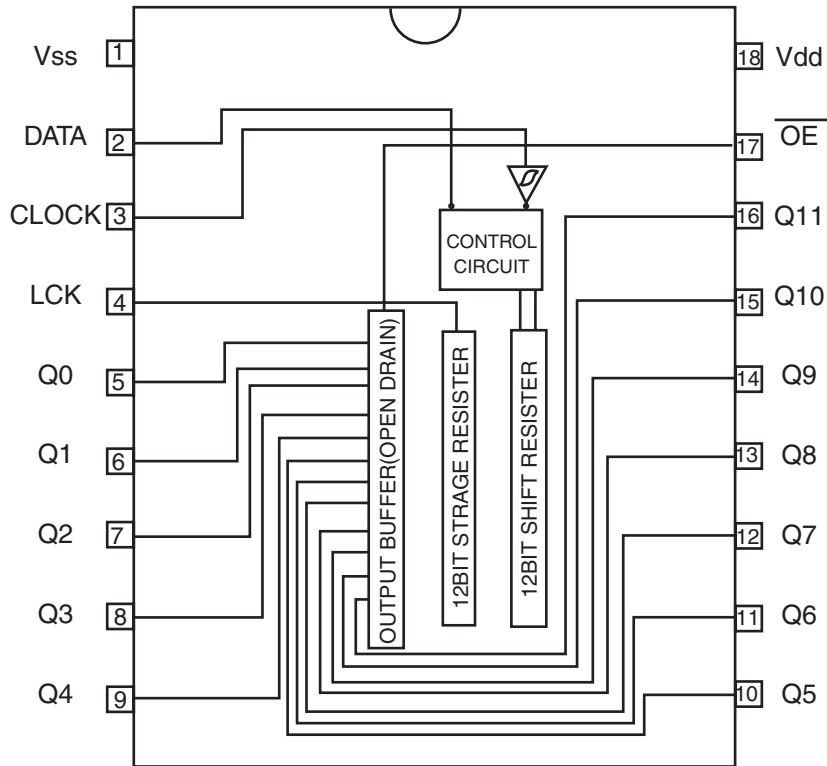

2.Pin function

Pin No.	Symbol	I/O	Function						
1	Vss	-	Connect to GND						
2	DATA	I	Serial Data input						
3	CLOCK	I	Shift Clock of Data						
4	LCK	I	Latch Clock of Data						
5~16	Q0~Q11	O	Parallel Data Output <table border="1" style="margin-left: 20px;"> <tr> <td>Latch Data</td> <td>L</td> <td>H</td> </tr> <tr> <td>OUTPUT</td> <td>ON</td> <td>OFF</td> </tr> </table>	Latch Data	L	H	OUTPUT	ON	OFF
Latch Data	L	H							
OUTPUT	ON	OFF							
17	$\overline{\text{OE}}$	I	Output Enable						
18	Vdd	-	Power Supply						

■ BH3874AKS (IC434) : Audio sound processor

1. Pin layout

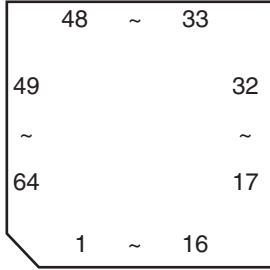

2. Block diagram

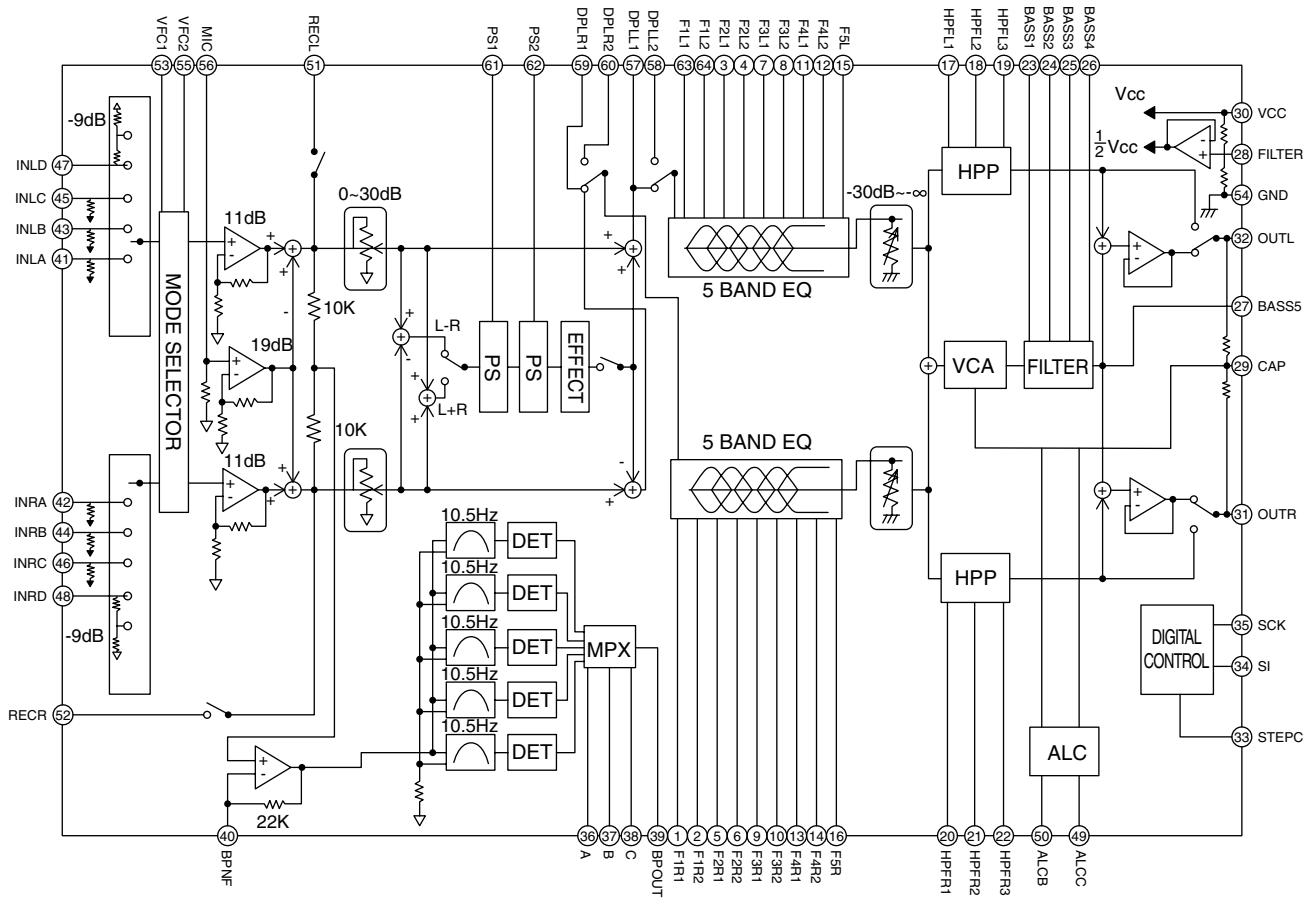

3. Pin function

Pin NO.	Name	Function	Pin NO.	Name	Function
1	F1R1	Rch GREQ f1 filter setting pin	34	SI	Serial data larch receiving pin
2	F1R2	Rch GREQ f1 filter setting pin	35	SCK	Serial clock receiving pin
3	F2L1	Lch GREQ f2 filter setting pin	36	A	Parallel data receiving pin
4	F2L2	Lch GREQ f2 filter setting pin	37	B	Parallel data receiving pin
5	F2R1	Rch GREQ f2 filter setting pin	38	C	Parallel data receiving pin
6	F2R2	Rch GREQ f2 filter setting pin	39	BPOUT	Output pin for spectrum analyzer
7	F3L1	Lch GREQ f3 filter setting pin	40	BPNF	Spectrum analyzer level setting pin
8	FAL2	Lch GREQ f3 filter setting pin	41	INLA	Lch input pin A
9	F3R1	Rch GREQ f3 filter setting pin	42	INRA	Rch input pin A
10	F3R2	Rch GREQ f3 filter setting pin	43	INLB	Lch input pin B
11	F4L1	Lch GREQ f4 filter setting pin	44	INRB	Rch input pin B
12	F4L2	Lch GREQ f4 filter setting pin	45	INLC	Lch input pin C
13	F4R1	Rch GREQ f4 filter setting pin	46	INRC	Rch input pin C
14	F4R2	Rch GREQ f4 filter setting pin	47	INLD	Lch input pin D
15	F5L	Lch GREQ f5 filter setting pin	48	INRD	Rch input pin D
16	F5R	Rch GREQ f5 filter setting pin	49	ALCC	Time constant of ALC setting pin
17	HPFL1	Lch high-pass filter setting pin	50	ALCR	ALC level setting pin
18	HPFL2	Lch high-pass filter setting pin	51	RECL	Lch RECOU output pin
19	HPFL3	Lch high-pass filter setting pin	52	REOR	Rch RECOU output pin
20	HPFR1	Rch high-pass filter setting pin	53	VFC1	Vocal fade filter setting pin
21	HPFR2	Rch high-pass filter setting pin	54	GND	Ground pin
22	HPFR3	Rch high-pass filter setting pin	55	VFC2	Vocal fade filter setting pin
23	BASS1	Dynamic bass filter setting pin	56	MIC	Input pin for microphone
24	BASS2	Dynamic bass filter setting pin	57	DPLL1	Lch output pin for DPL
25	BASS3	Dynamic bass filter setting pin	58	DPLL2	Lch input pin for DPL
26	BASS4	Dynamic bass filter setting pin	59	DPLR1	Rch output pin for DPL
27	BASS5	Biamp output pin	60	DPLR2	Rch input pin for DPL
28	FILTER	VCC/2 pin	61	PS1	Surround setting pin
29	CAP	ALC trap frequency setting pin	62	PS2	Surround setting pin
30	VCC	Power supply pin	63	F1L1	Lch GREQ f1 filter setting pin
31	OUTR	Rch output pin	64	F1L2	Lch GREQ f1 filter setting pin
32	OUTL	Lch output pin			
33	STEPC	Time conatant attachment for switching shook protection			

■ KIA7805API (IC360) : Regulator

1. Pin layout

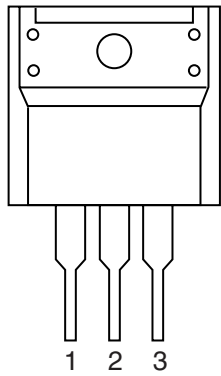

- 1.VCC
- 2.GND
- 3.OUTPUT

2.Block diagram

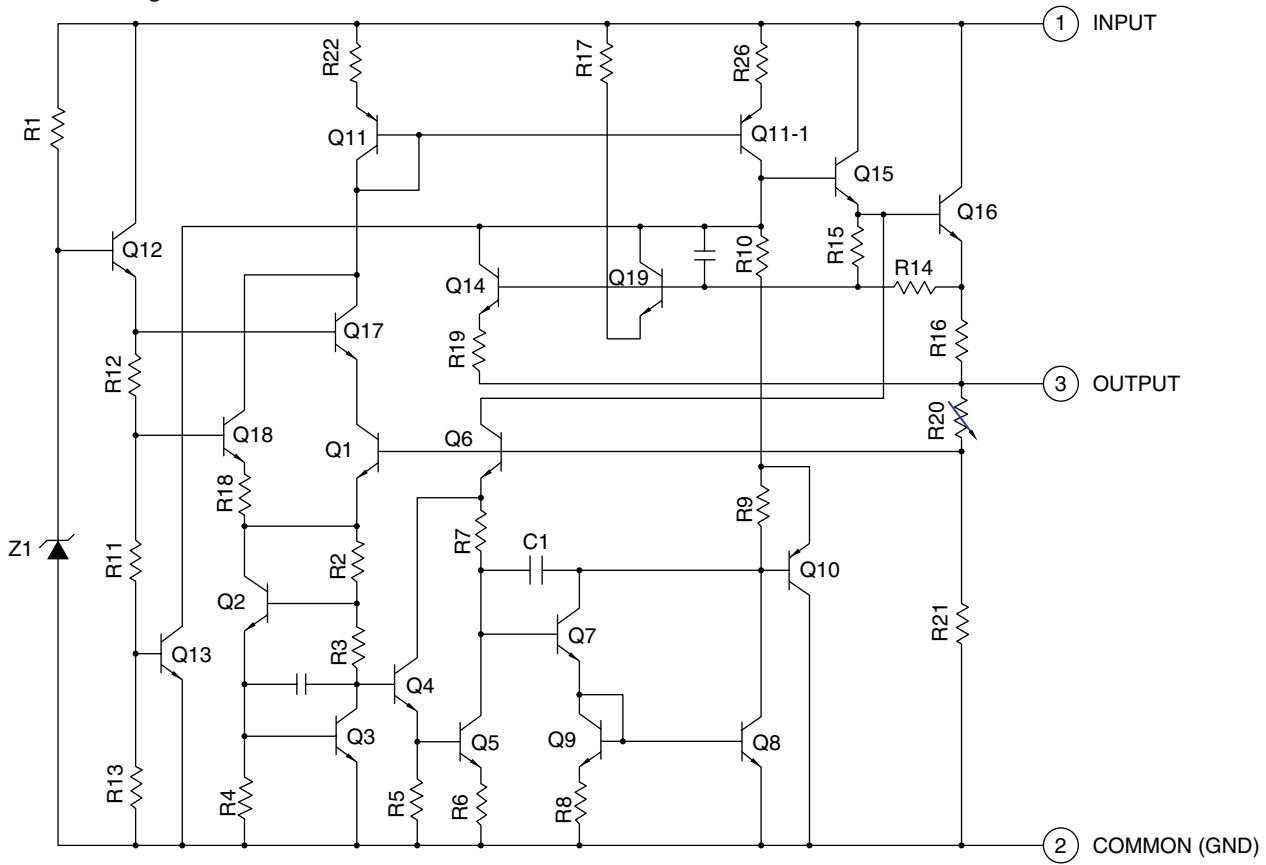

KIA7808API (IC303) : Regulator

1. Pin layout

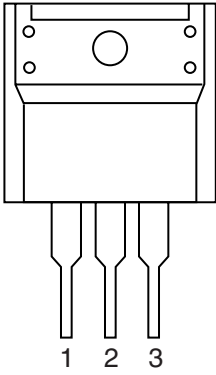

- 1.VCC
- 2.GND
- 3.OUTPUT

2. Block diagram

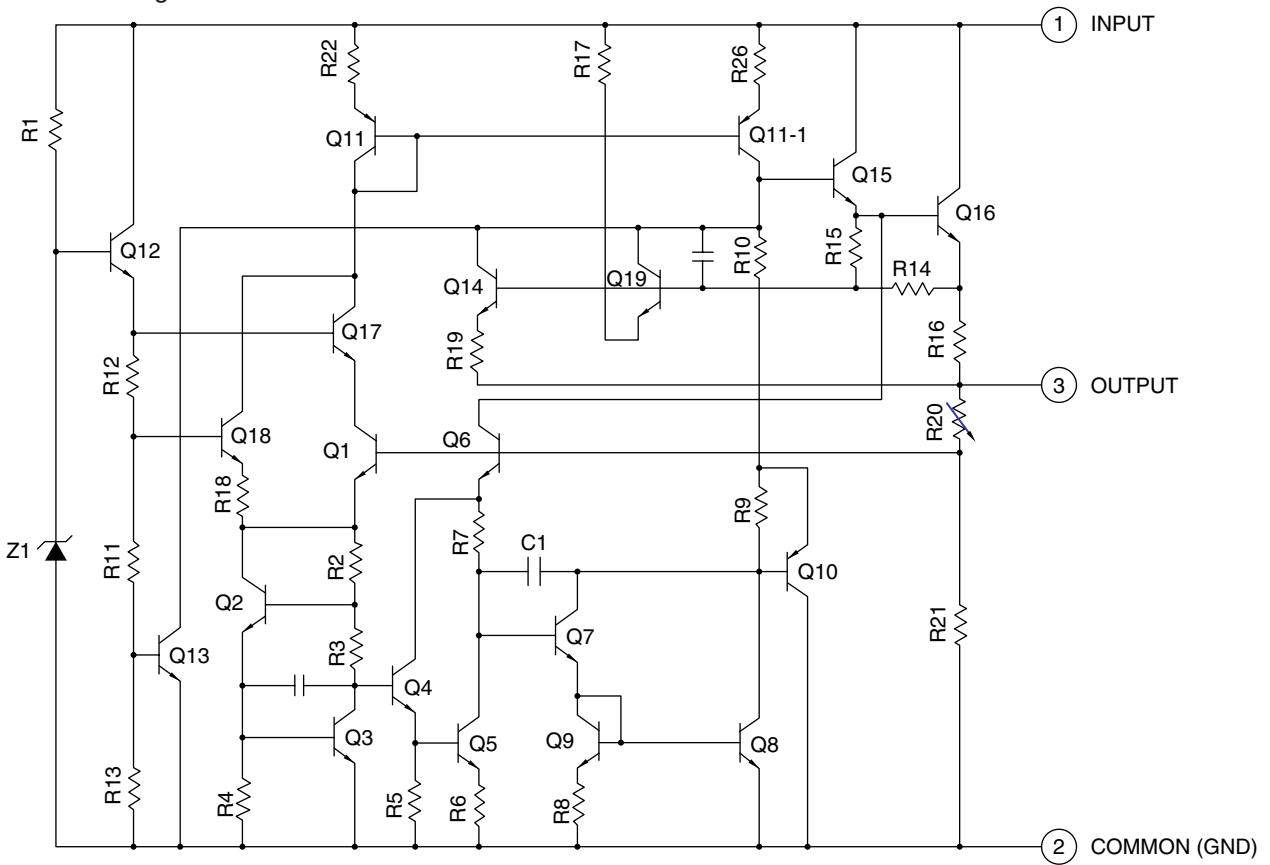

■ KIA7812API (IC240) : Regulator

1. Pin layout

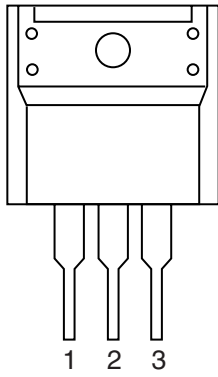

1.VCC
2.GND
3.OUTPUT

2.Block diagram

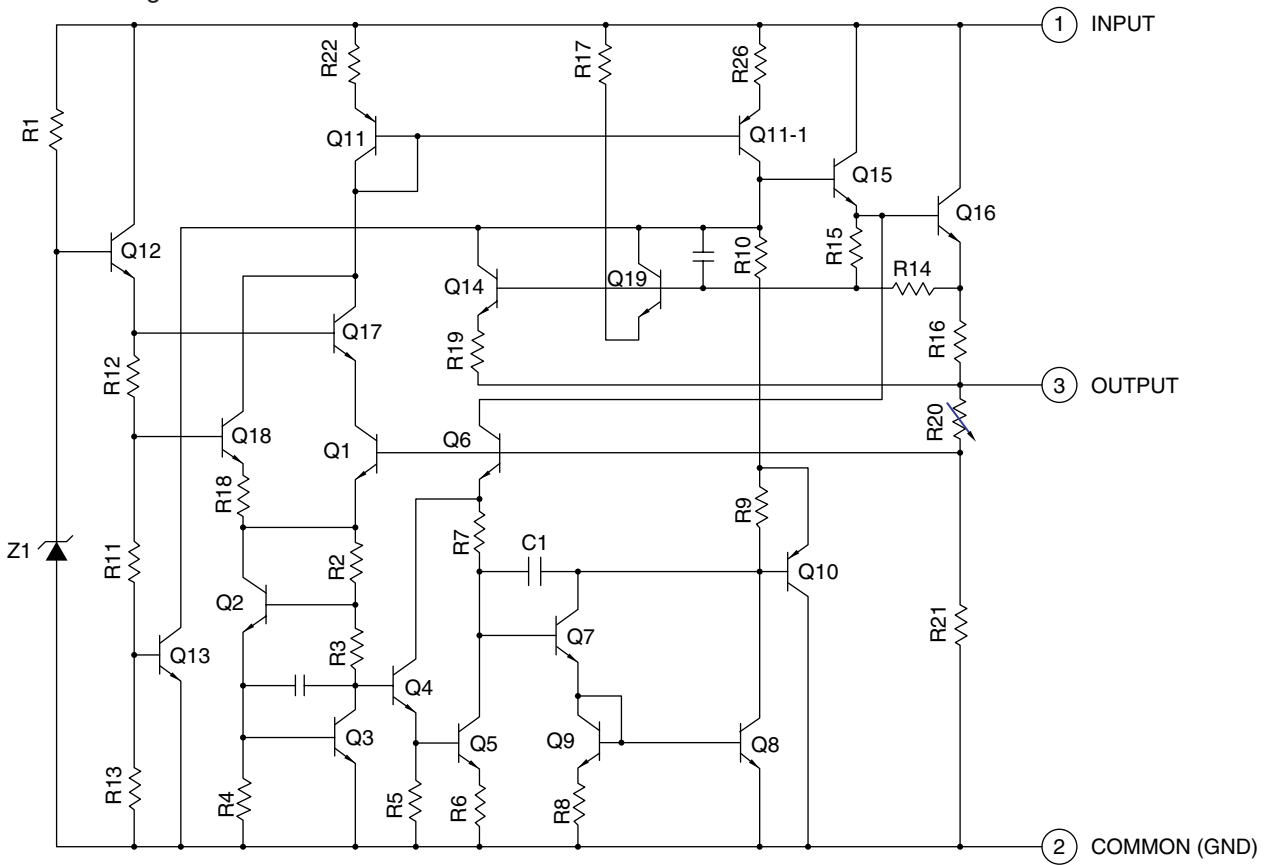

■ KIA7042AP-T (IC830) : Regulator

1. Pin layout

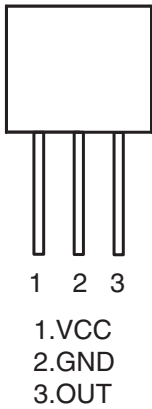

2. Block diagram

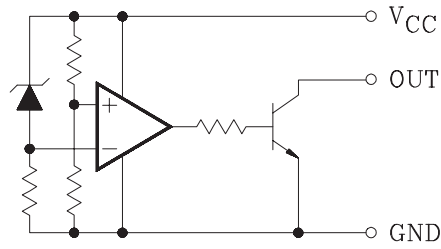

■ NJM4580D (IC501, IC502, IC571) : LPF, Mic and H.phone amp.

1. Pin layout

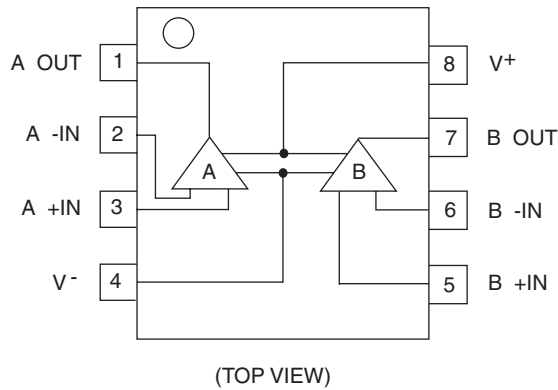

2. Block diagram

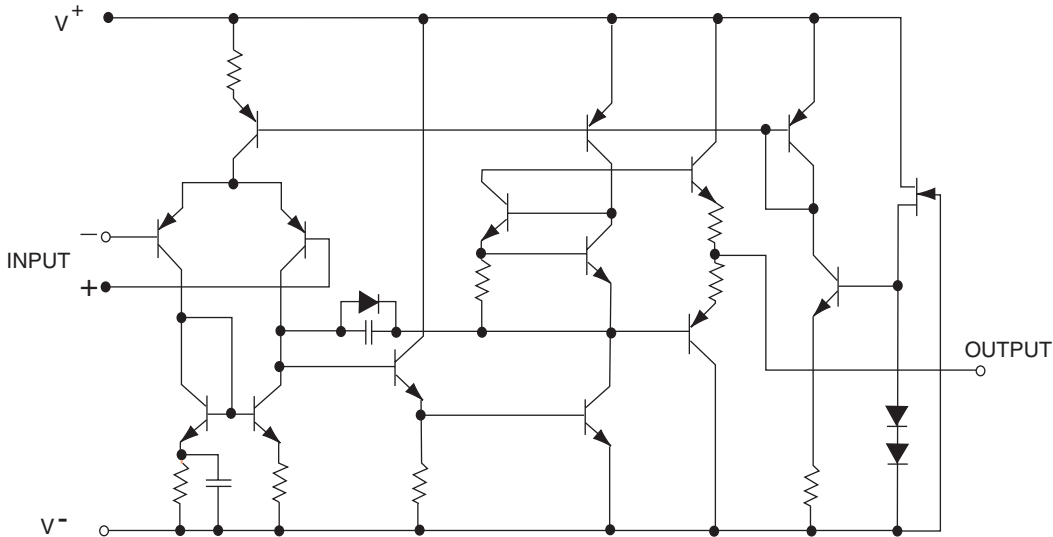

■ GP1U271XK (IC951) : Receiver for remote

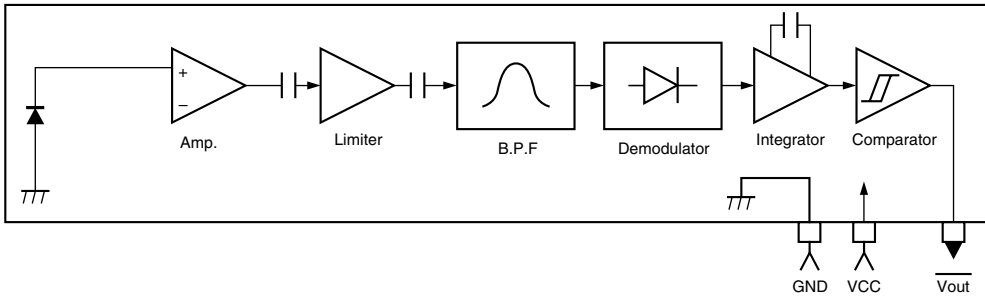

■ STK402-050 (IC602) : 2ch AF power amp.

1.Pin layout

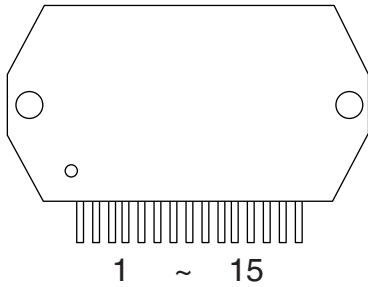

2.Block diagram

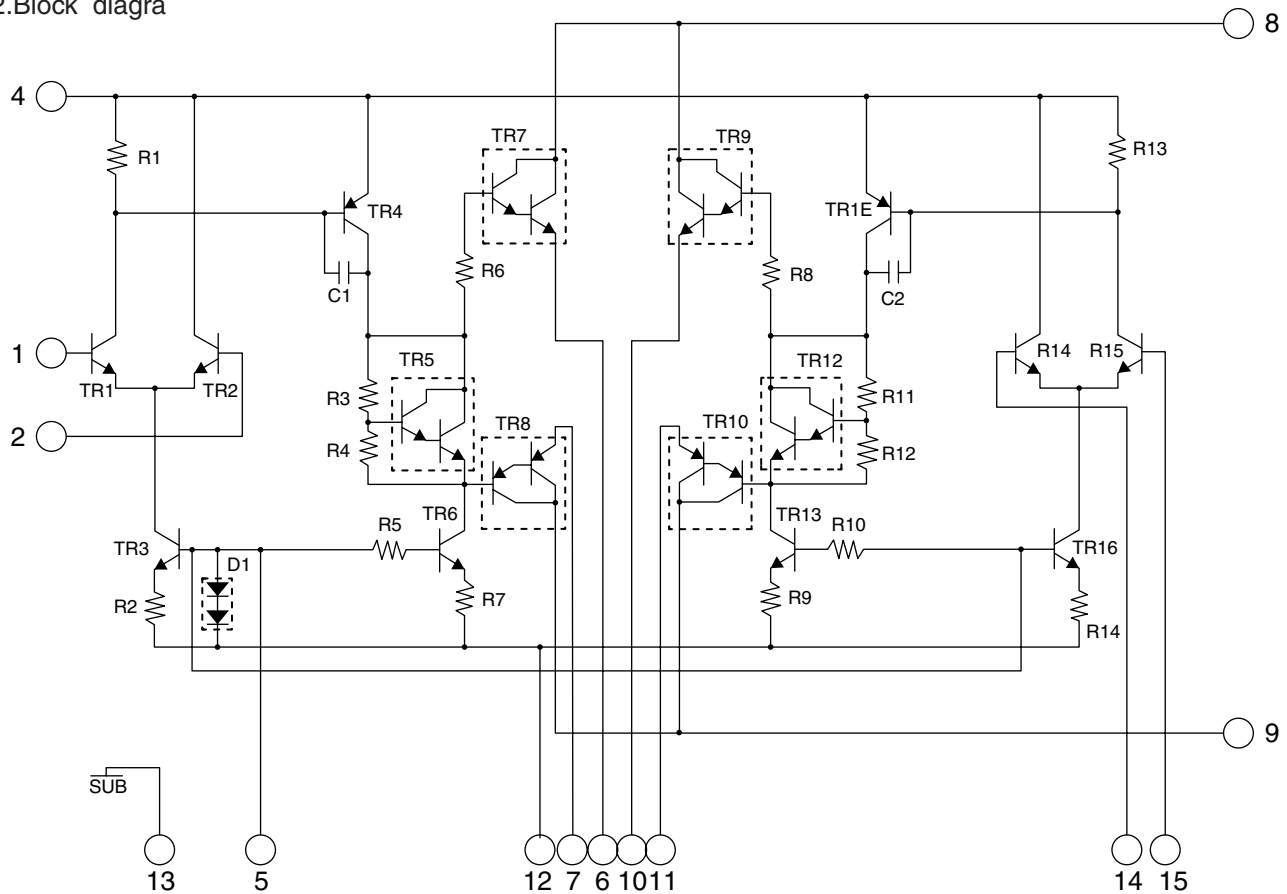

■ STK402-010 (IC701) : 2ch AF power amp.

1.Pin layout

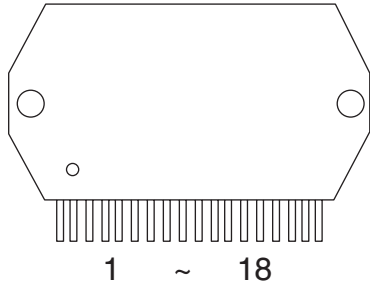

2.Block diagram

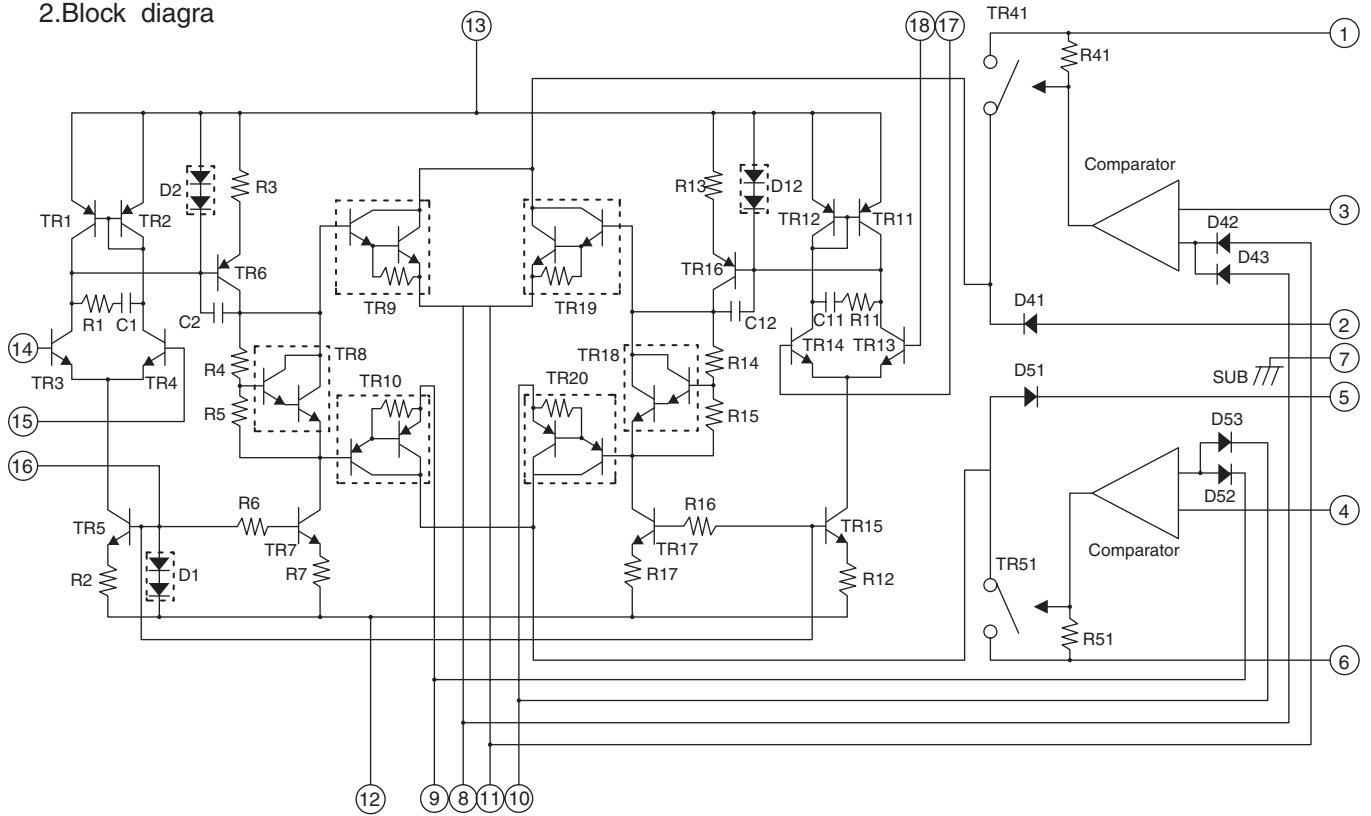

■ UPD784975AGF303 (IC810) : Main micon

1. Pin layout

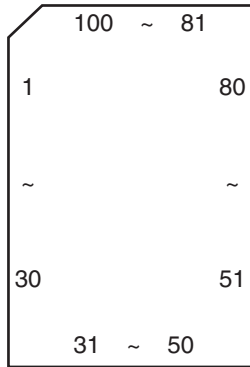

2. Pin function

Pin NO.	Name	I/O	Function	Pin NO.	Name	I/O	Function
1	AVDD	-	AD VDD, same as VDD1	36	SPI A	I/O	SPI A data
2	SPIDTI	I	SPI analog input	37	SPI B	I/O	SPI B data
3	MSI	I	Music scan input	38	SPI C	I/O	SPI C data
4	MPX	I	Tuner stereo indicator	39	PBMUTE	I/O	Playback mute
5	H/P	I	SW vol IC btw bi-amp & dyn & off relay	40	VSS0	-	
6	KEY1	I	Key 1 input	41	VDD0	-	
7	KEY2	I	Key 2 input	42	RESET	I	Micom reset
8	KEY3	I	Key 3 input	43	INH	I/O	Back-up mode detect
9	VOL-	I	Volume decrease	44	LATCH	I/O	Latch for vol IC
10	VOL+	I	Volume increase	45	VOLCK	I/O	Volume clock
11	SLCPLAY	I	SLC detect play	46	VOLDA	I/O	Volume data
12	SLCKEY	I	SLC key input	47	RELAY	I/O	Relay out
13	PHOTO A	I	SLC photo A	48	POUT	I/O	Power on
14	AVSS	-	AD VDD, same as VSS1	49	ECON	I/O	Ecology mode
15	VSS1	-	GND	50	PRT	I/O	Protector in
16	X1	I	Oscillation	51	AUXMUTE	O	Auxmute
17	X2	-	Oscillation	52	TUCE	O	Tuner chip enable
18	VDD1	-		53		O	Available pin
19	IC(VPP)	-	Connect to VSS1	54		O	Available pin
20	VC3RESET	I/O	VC3 reset	55	EXTDA	O	External IC data
21	MSTAT	I/O	VC3 status input	56	EXTCK	O	External IC clock
22	KCMND	I/O	VC3 KCMND(serial data)	57	EXTCE	O	External IC strobe
23	RDS DATA	I/O	RDS data	58	OEEXT	O	Output enable for external IC
24	RDS CK	INT	RDS clock	59	VOLLED	I/O	Volume led
25	BUZZER	I/O	Buzzer on	60	FSEARCH	I/O	Forward skip
26	REMIN	INT	Remocon input	61	RSEARCH	I/O	Reverse skip
27	SMUTE	I/O	System mute	62~78	S21~S5	I/O	FL segment
28	SLCCE	I/O	SLC chip enable	79	VDD2	I/O	
29	CK	I/O	SLC / tuner clock	80	VLOAD	I/O	Negative power supply(-30V)
30	DATA OUT	I/O	SLC / tuner data out	81~84	S4~S1	I/O	FL segment
31	DATA IN	I/O	Tuner data in	85~100	G16~G1	I/O	FL display grid
32	SM-	I/O	Soundmode reverse				
33	SM+	I/O	Soundmode forward				
34	ECHO1	I/O	Echo 1 data				
35	ECHO2	I/O	Echo 2 data				

■ KIA7809API (IC305) : Regulator

1.Pin layout

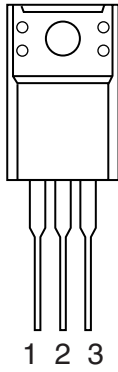

1.INPUT
2.COMMON
3.OUTPUT

2.Block diagram

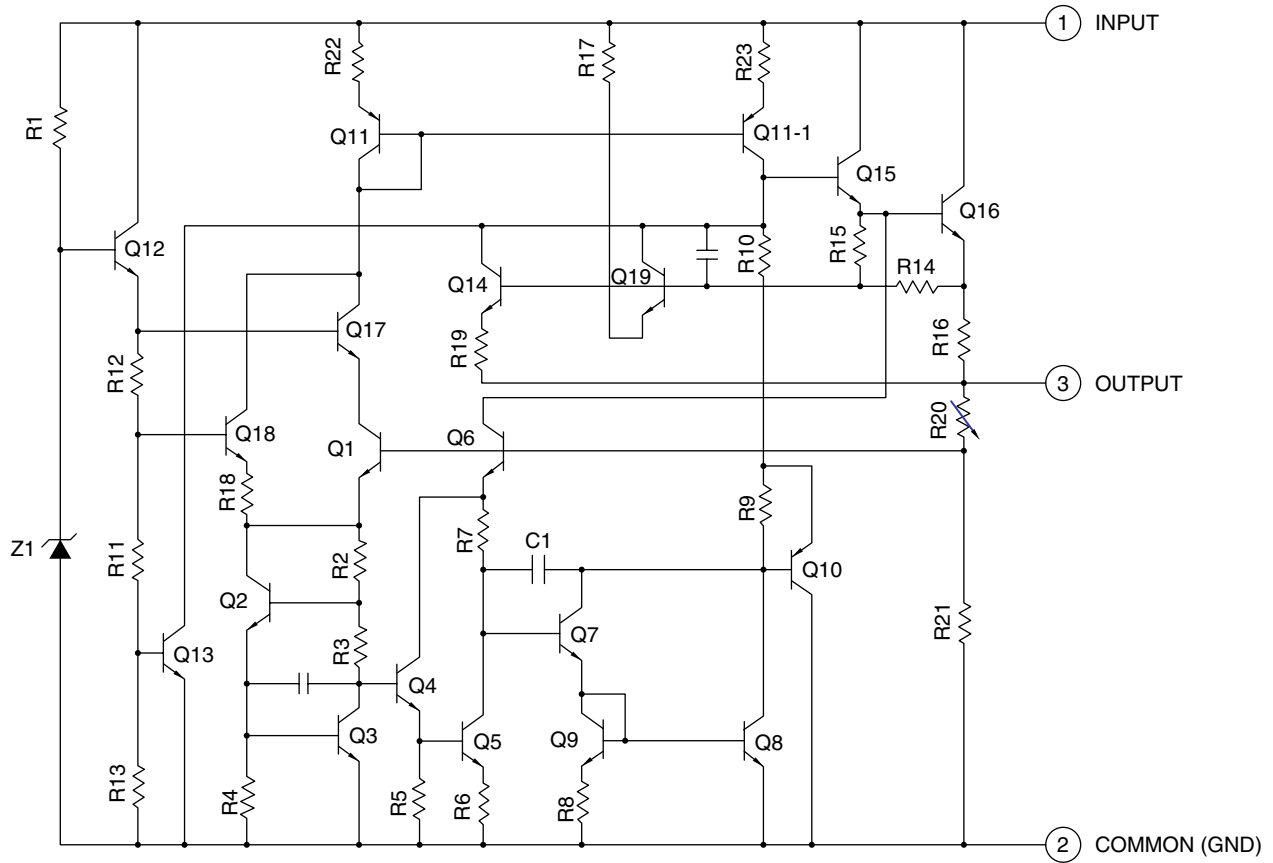



VICTOR COMPANY OF JAPAN, LIMITED

AUDIO & COMMUNICATION BUSINESS DIVISION

PERSONAL & MOBILE NETWORK BUSINESS UNIT. 10-1,1chome,Ohwatari-machi,Maebashi-city,371-8543,Japan

JVC

SCHEMATIC DIAGRAMS

COMPACT COMPONENT SYSTEM

HX-Z1

CD-ROM No.SML200206

Area Suffix

J U.S.A.
C Canada

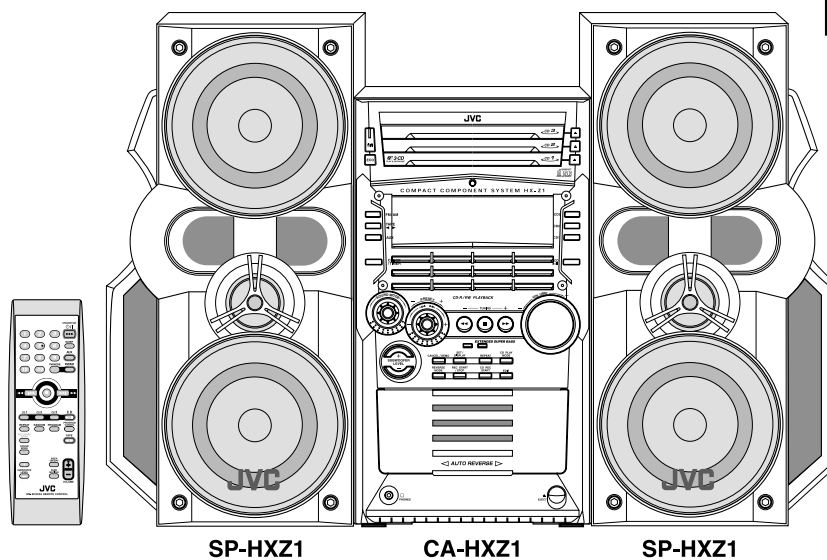

COMPACT
disc
DIGITAL AUDIO

Contents

Block diagram	2-1
Standard schematic diagrams	2-2
Printed circuit boards	2-10~16

Block diagram

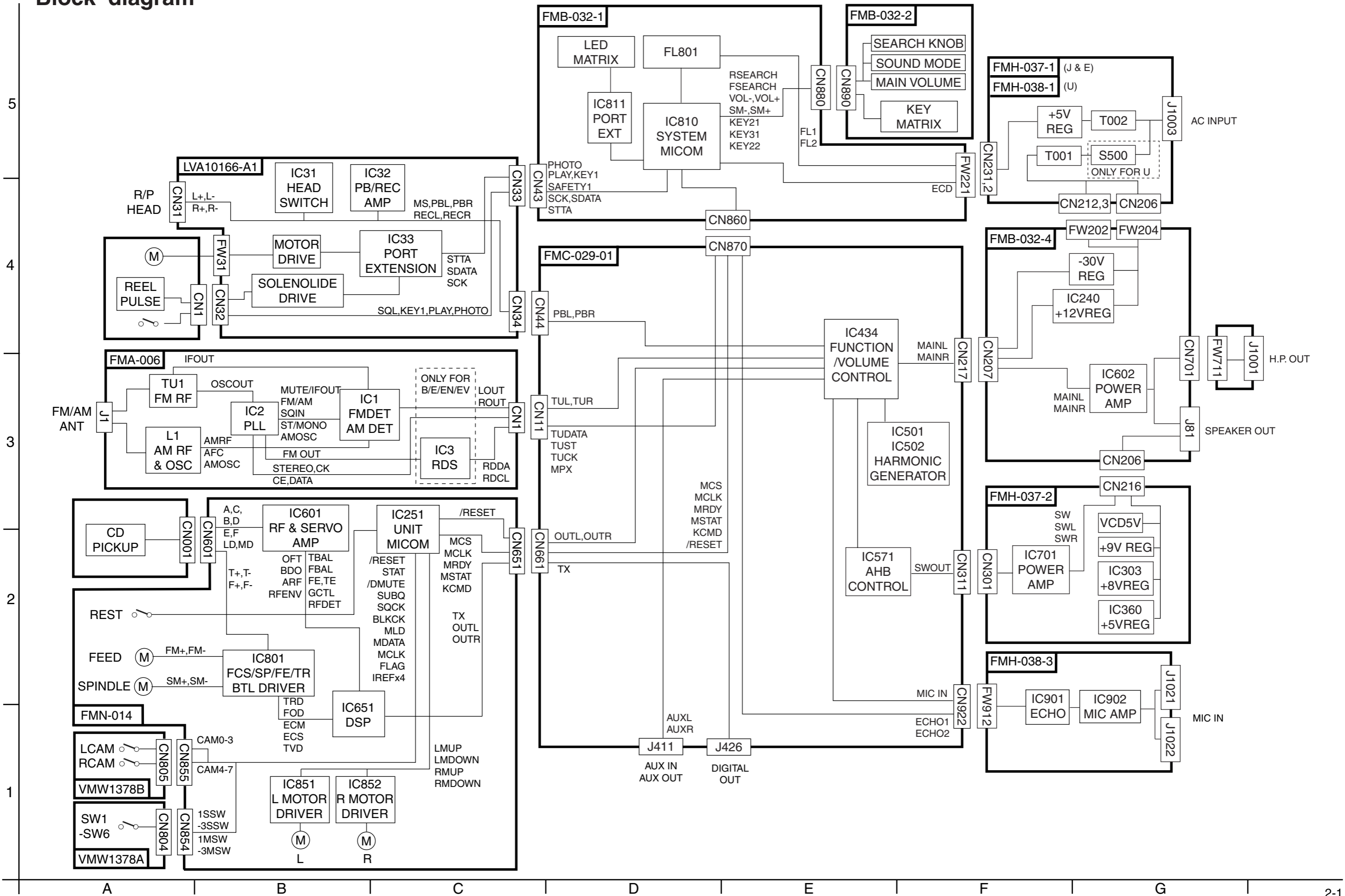

Standard schematic diagrams

■ Front circuit

5

4

3

2

1

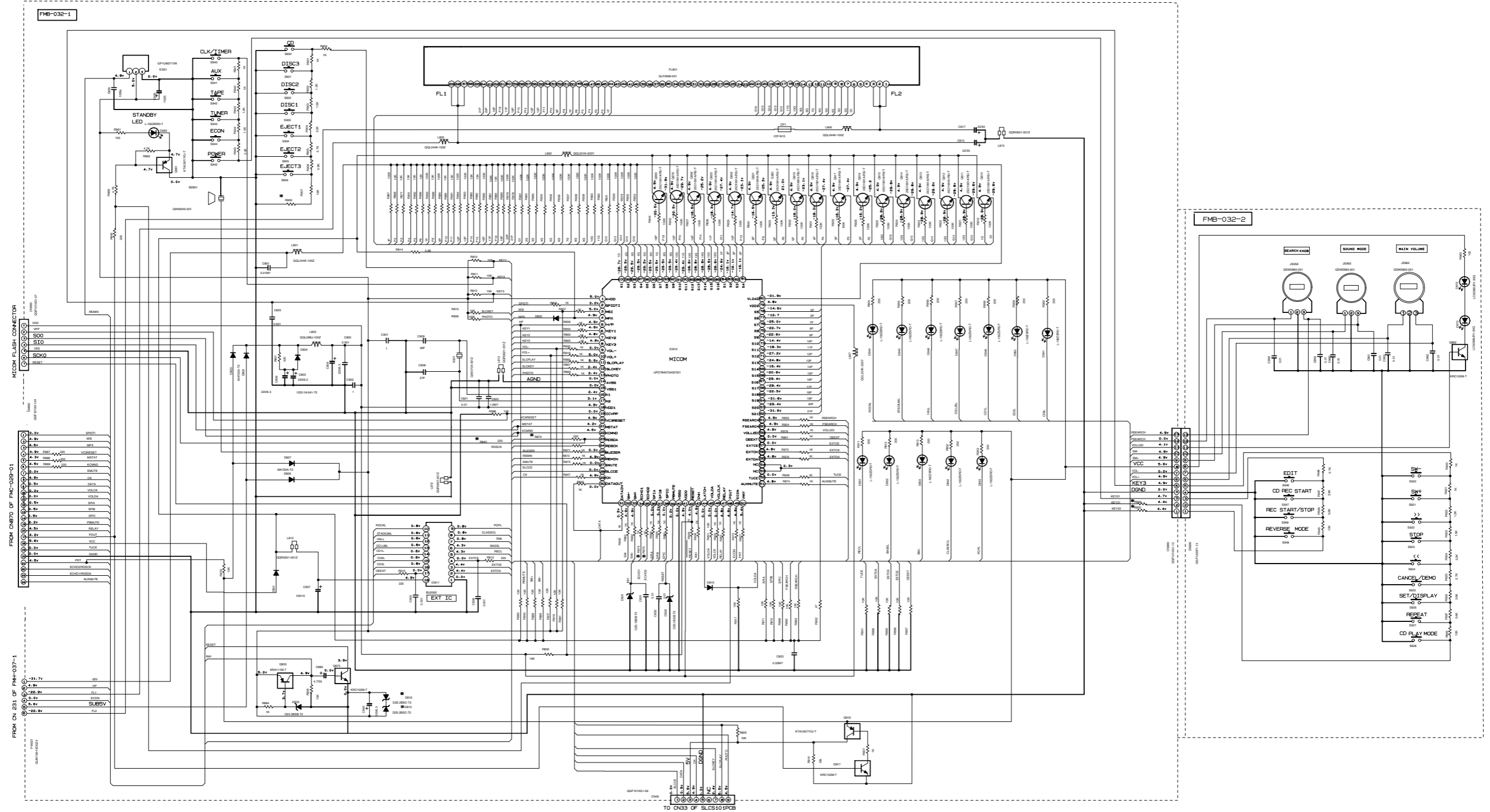

MARK	HXZ-1					HXZ-3				
	B-E-EN-EV	A	J-C	U-UJ-UT-UW	UY	B-E-EN-EV	A	J-C	U-UJ-UT-UW	UY
R909	330K	330K	330K		330K	75K	75K	75K		75K
R929	75K	330K	330K	330K	75K	75K	330K	330K	330K	75K
R950	330K	10K	330K	75K	330K	330K	10K	330K	75K	75K
RB43-RB70	USE	NONE	NONE	NONE	NONE	USE	NONE	NONE	NONE	NONE
RB74-RB75	NONE	NONE	NONE	USE	USE	NONE	NONE	NONE	USE	USE
DB15-DB16	DZ6.2BSC-T2	DZ6.2BSC-T2	NONE	NONE	NONE	DZ6.2BSC-T2	DZ6.2BSC-T2	NONE	NONE	NONE

NOTE: FOR VCD MODEL CB40 CHANGE TO 100/10 AND REPLACE BB150 BY 68 OHM RESISTOR

- NOTES
- VOLTAGES ARE DC-MEASURED WITH A DIGITAL VOLT METER OR OSCILLOSCOPE WITHOUT INPUT SIGNAL. CONDITION — AUX MODE- VOL. MIN- BASS OFF
 - UNLESS OTHERWISE SPECIFIED:
 - RESISTORS ARE 1/4W ± 5% CARBON RESISTOR.
 - ALL RESISTANCE VALUES ARE IN OHMS.
 - ALL CAPACITORS ARE CERAMIC CAPACITOR OR MLAR CAPACITOR.
 - ALL CAPACITANCE VALUES ARE IN PICO(F).
 - ALL INDUCTANCE VALUES ARE IN HENRY(H).
 - ALL CAPACITORS ARE SHOWN IN THE FORM OF CAPACITANCE (μF)/RATED VOLTAGE (V).
 - ALL DIODES ARE 1SS119-041-T2
 - ALL TACT SWITCH ARE 0260674-0012

■ Main circuit

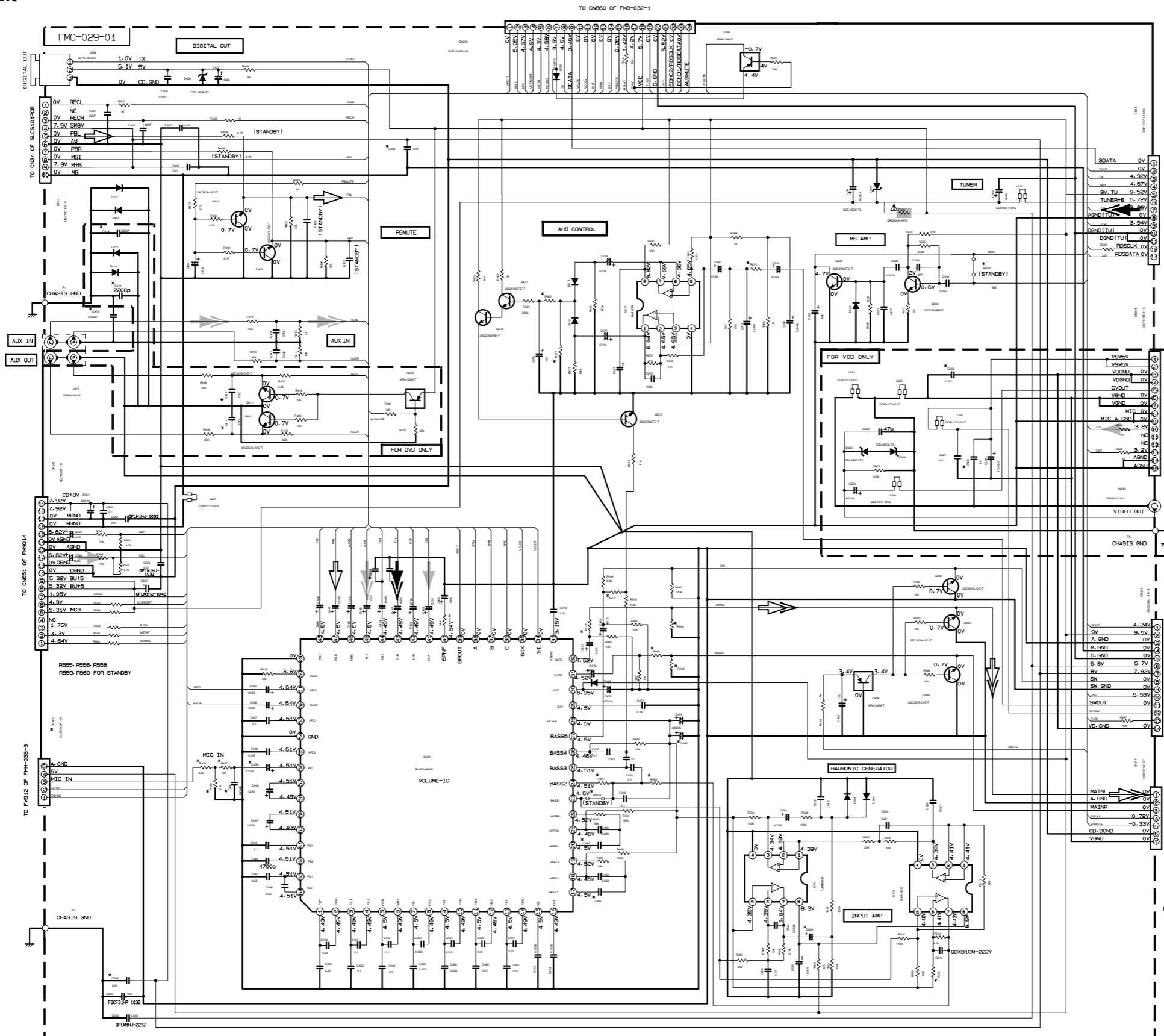

MARK *

MODEL	HXZ1 & HXZ3				
VERSION	J/C	B/E EN/EV	A	UT/LW U/UJ	UY
C408	NONE	F00731P-103Z			NONE
C558	NONE	F00731P-103Z			NONE
C563	NONE	G1M1H-222Z			NONE
C564	NONE	G1M1H-222Z			NONE
R477	GRE141J-123Y	GRE141J-123Y			GRE141J-682Y
R538	NONE	GRE141J-221Y			NONE
CN922	NONE	NONE		G5D503F1-05	NONE
CN970	GQF1205F1-21	GQF1205F1-23	GQF1205F1-21	GQF1205F1-21	GQF1205F1-21
CN11	GQF1205F1-09	GQF1205F1-13	GQF1205F1-09	GQF1205F1-09	GQF1205F1-09
R436	NONE	NONE			GRE141J-682Y
R437	NONE	NONE			GRE141J-101Y
R438	NONE	NONE			GRE141J-513Y
C439	NONE	NONE			GETN1M-225Z
C441	NONE	NONE			GFLM1H-682Z

MARK *

MODEL	HX-Z1		HX-Z3	
VERSION	J/C/A/B/E/EN UT/LW/U/UJ/UY		J/C/A/B/E/EN UT/LW/U/UJ/UY	
R442	GRE141J-682Y		GRE141J-472Y	
R443	GRE141J-243Y		GRE141J-103Y	
R444	GRE141J-682Y		GRE141J-472Y	
R445	GRE141J-243Y		GRE141J-103Y	
R451	GRE141J-183Y		GRE141J-153Y	
R452	GRE141J-682Y		GRE141J-822Y	
R513	GRE141J-103Y		GRE141J-822Y	
R570	GRE141J-562Y		GRE141J-622Y	
R579	GRE141J-154Y		GRE141J-224Y	
R580	GRE141J-682Y		GRE141J-223Y	
C465	GQF32AJ-223Z		GQF20160-223Z	
C467	GQF32AJ-223Z		GQF20160-223Z	
C469			GTE1006-472Z	
C509	GETN1M-475Z		GETN1M-106Z	

	REFERENCE NUMBER	POSITION
TAPE	401 - 409	
AUX IN	410 - 421	
DIGITAL OUT	426 - 427	
VOLUME IC	434 - 499	
SUPPLY	493 - 497	
HARMONIC GENERATOR	501 - 515	
VCD	523 - 529	
TUNER	533 - 539	
TO FMB	545 - 548	
VIDEO	551 - 560	
AHB CONTROL	570 - 588	

NOTES

- VOLTAGES ARE DC-MEASURED WITH A DIGITAL VOLT METER OR OSCILLOSCOPE WITHOUT INPUT SIGNAL.
CONDITION - AUX KEYS: VOL. MDN. SUBWOOFER VOL. 1.
- UNLESS OTHERWISE SPECIFIED:
RESISTORS ARE 1/4W ±5% CARBON RESISTOR.
ALL RESISTANCE VALUES ARE IN OHM (Ω).
ALL CAPACITORS ARE CERAMIC CAPACITOR OR MYLAR CAPACITOR.
ALL CAPACITANCE VALUES ARE IN μF(μF).
ALL INDUCTANCE VALUES ARE IN mH(mH).
ALL CAPACITORS ARE SHOWN IN THE FORM OF CAPACITANCE (μF)/RATED VOLTAGE (V).
ALL DIODES ARE 1SS119-041-12.

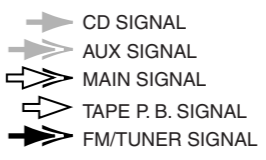

▲ Parts are safety assurance parts.
When replacing those parts make sure to use the specified one.

Power amplifier & Power supply circuit

5
4
3
2
1

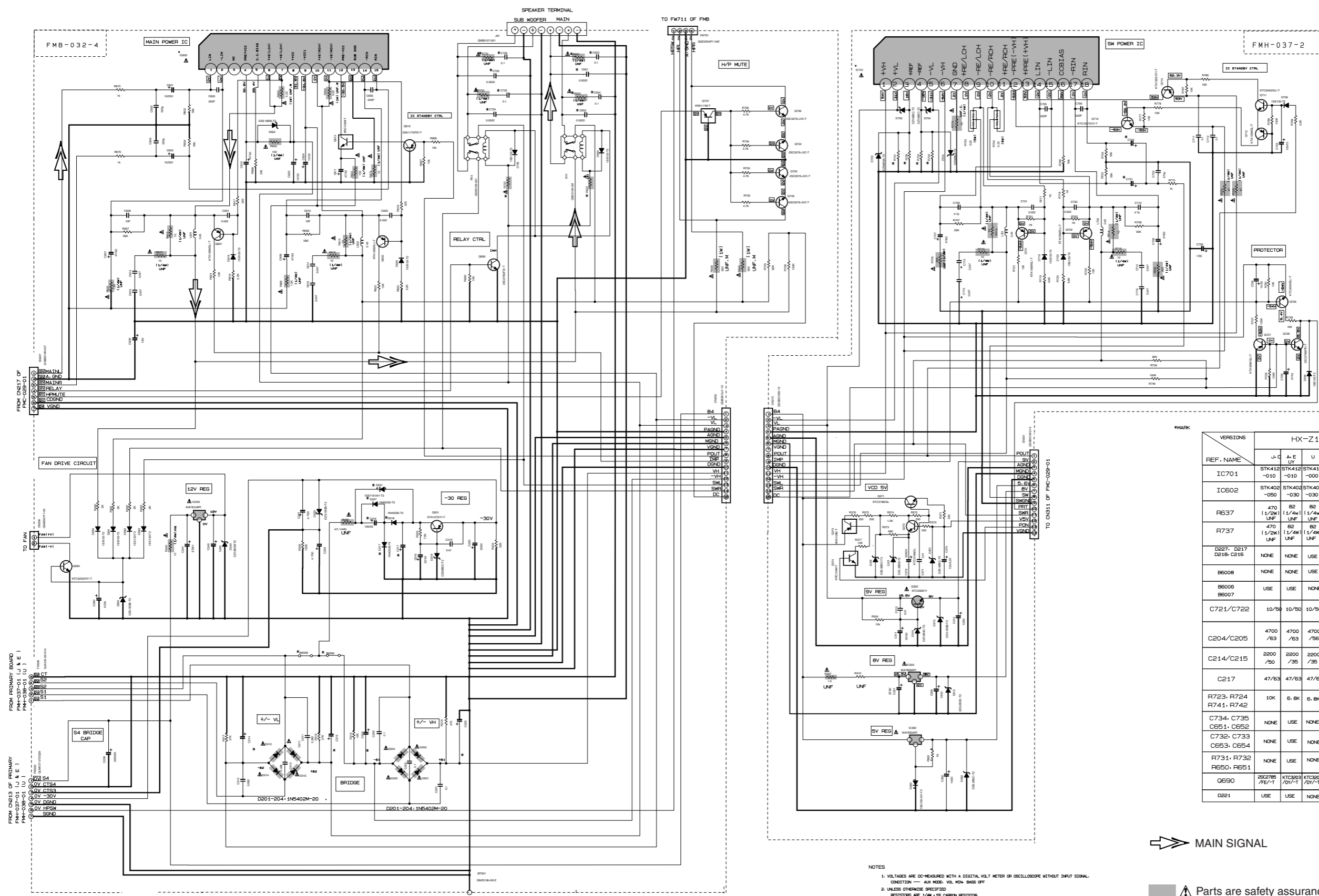

VERSIONS REF. NAME	HX-Z1				HX-Z3			
	J-C	A-E	U	UT	J-C	A-E	U	UT
IC701	STK412-010	STK412-010	-000	STK412-000	STK412-020	STK412-010	STK412-010	STK412-010
IC602	STK402-050	STK402-030	STK402-030	STK402-030	STK402-070	STK402-050	STK402-050	STK402-050
R637	470 (1/2W) UNF	82 (1/4W) UNF	82 (1/4W) UNF	82 (1/4W) UNF	470 (1/2W) UNF	82 (1/4W) UNF	82 (1/4W) UNF	82 (1/4W) UNF
R737	470 (1/2W) UNF	82 (1/4W) UNF	82 (1/4W) UNF	82 (1/4W) UNF	470 (1/2W) UNF	82 (1/4W) UNF	82 (1/4W) UNF	82 (1/4W) UNF
D227, D217 D218, C216	NONE	NONE	USE	USE	NONE	NONE	USE	USE
B6008	NONE	NONE	USE	NONE	NONE	NONE	USE	NONE
B6006 B6007	USE	USE	NONE	USE	USE	USE	NONE	USE
C721/C722	10/50	10/50	10/50	10/50	10/35	10/35	10/35	10/35
C204/C205	4700 /63	4700 /63	4700 /56	4700 /56	4700 /63	4700 /63	4700 /63	4700 /63
C214/C215	2200 /50	2200 /35	2200 /35	2200 /35	2200 /50	2200 /50	2200 /50	2200 /50
C217	47/63	47/63	47/63	47/63	47/100	47/100	47/100	47/100
R723, R724 R741, R742	10K	6.8K	6.8K	6.8K	10K	6.8K	6.8K	6.8K
C734, C735 C651, C652	NONE	USE	NONE	NONE	USE	NONE	NONE	NONE
C732, C733 C653, C654	NONE	USE	NONE	NONE	USE	NONE	NONE	NONE
R731, R732 R650, R651	NONE	USE	NONE	NONE	USE	NONE	NONE	NONE
Q690	2SC785 /RE-1	KTC300 /OV-1	KTC300 /OV-1	KTC300 /OV-1	2SC785 /RE-1	KTC300 /OV-1	KTC300 /OV-1	KTC300 /OV-1
D221	USE	USE	NONE	NONE	USE	USE	NONE	NONE

MAIN SIGNAL

NOTES
 1. VOLTAGES ARE DC-MEASURED WITH A DIGITAL VOLT METER OR OSCILLOSCOPE WITHOUT INPUT SIGNAL. CONDITION — AUX MODE, VOL. MIN, BASS OFF
 2. UNLESS OTHERWISE SPECIFIED
 RESISTORS ARE 1/4W ± 5% CARBON RESISTOR.
 ALL RESISTANCE VALUES ARE IN OHM Ω.
 ALL CAPACITORS ARE CERAMIC CAPACITOR OR MILAR CAPACITOR.
 ALL CAPACITANCE VALUES ARE IN pF (PF).
 ALL INDUCTANCE VALUES ARE IN mH (MH).
 ALL ELECTROLYTIC CAPACITORS ARE IN μF (MF).
 ALL ELECTROLYTIC CAPACITORS ARE 50V IN THE FORM OF CAPACITANCE (μF/RATED VOLTAGE (V)).

Parts are safety assurance parts.
 When replacing those parts make sure to use the specified one.

A B C 2-4 D E F G

CD control circuit

5
4
3
2
1

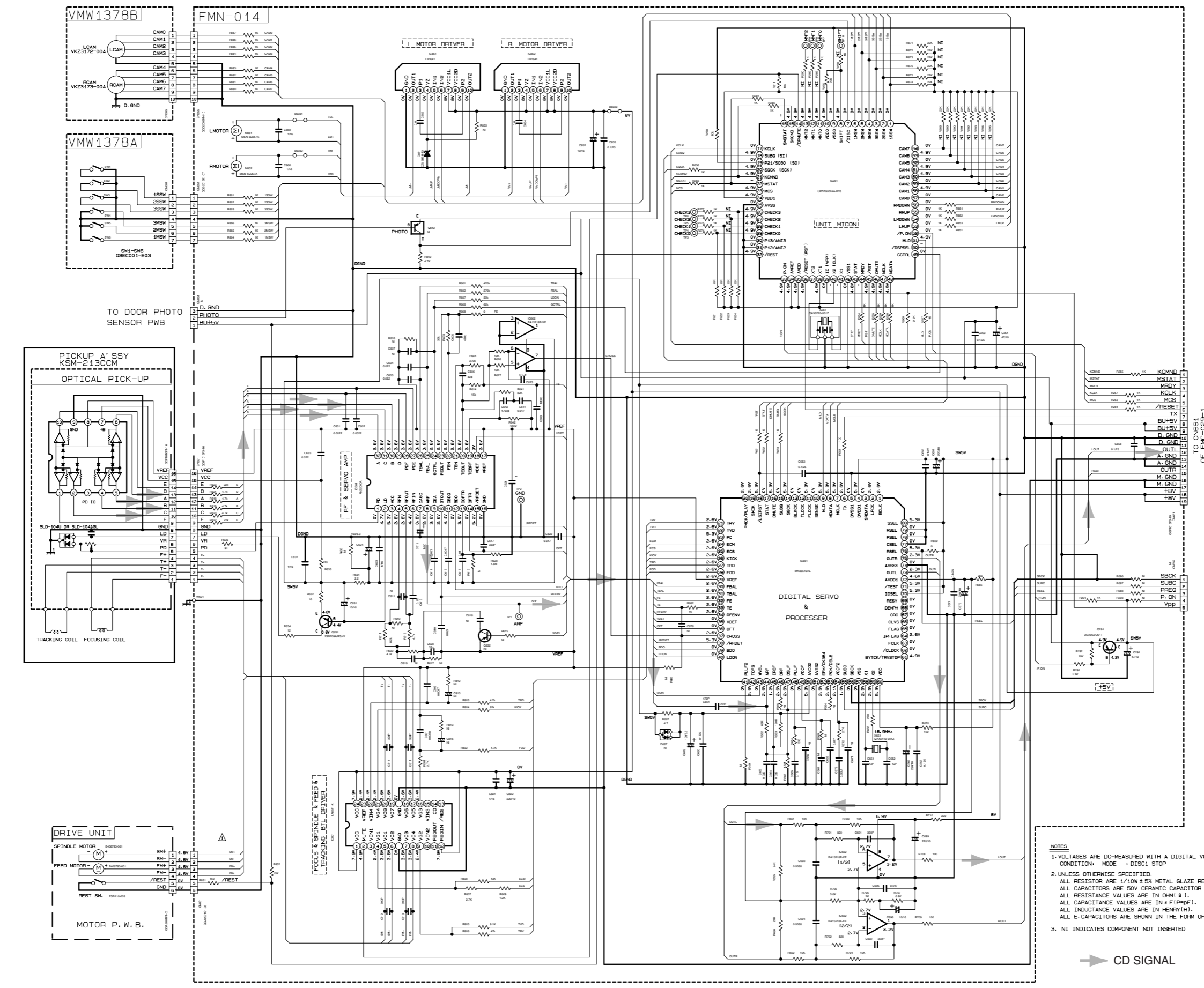

- NOTES
1. VOLTAGES ARE DC-MEASURED WITH A DIGITAL VOLT METER
CONDITION: MODE : DISC1 STOP
 2. UNLESS OTHERWISE SPECIFIED.
ALL RESISTOR ARE 1/10W ± 5% METAL GLAZE RESISTOR.
ALL CAPACITORS ARE 50V CERAMIC CAPACITOR OR 50V MYLAR CAPACITOR.
ALL RESISTANCE VALUES ARE IN OHM (Ω).
ALL CAPACITANCE VALUES ARE IN PICO-FARAD (pF).
ALL INDUCTANCE VALUES ARE IN HENRY (H).
ALL E-CAPACITORS ARE SHOWN IN THE FORM OF CAPACITANCE (μF) / RATED VOLTAGE (V).
 3. NI INDICATES COMPONENT NOT INSERTED

➔ CD SIGNAL

■ Cassette amplifier circuit

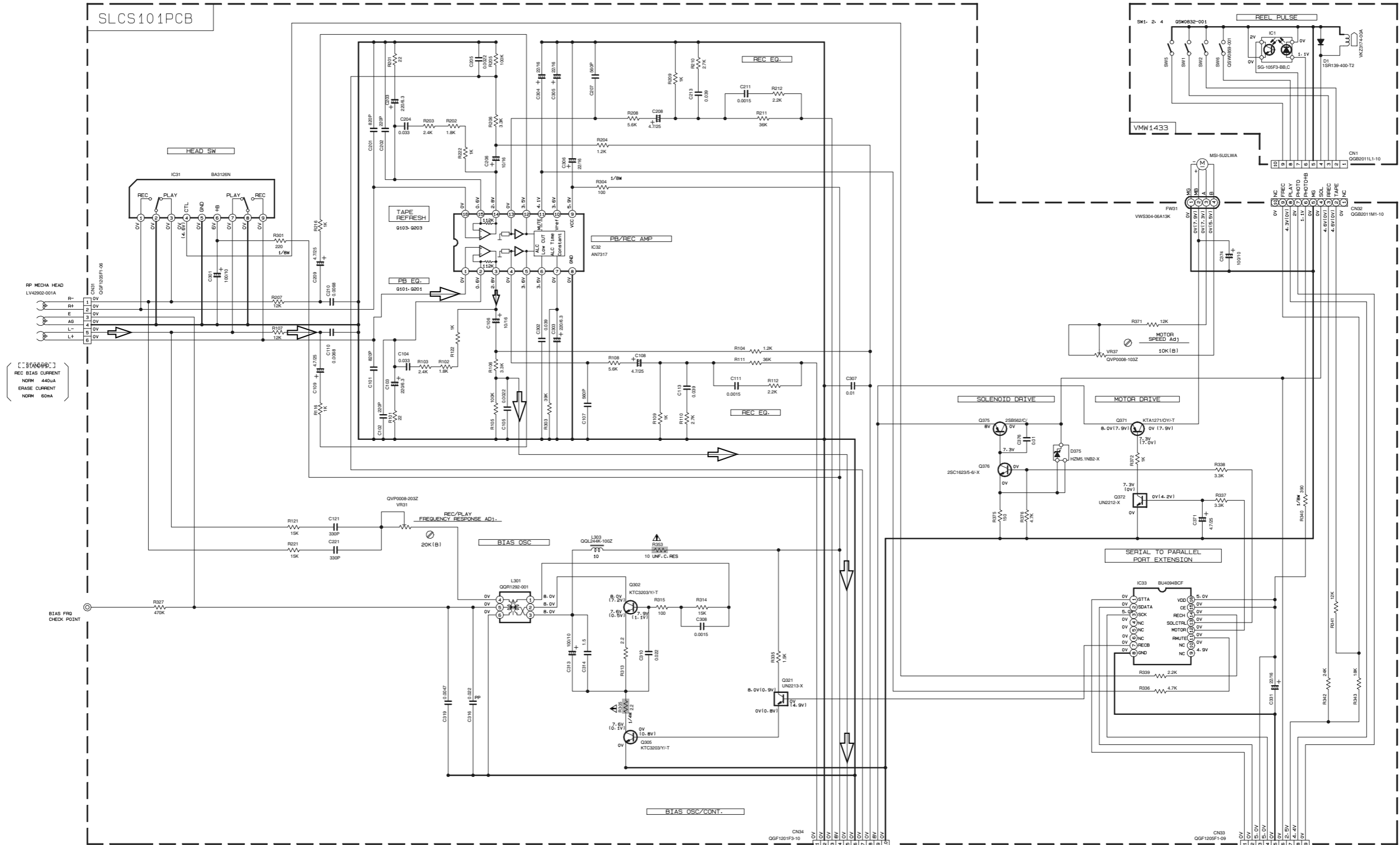

NOTES

- VOLTAGES ARE DC-MEASURED WITH A DIGITAL VOLT METER OR OSCILLOSCOPE WITHOUT INPUT SIGNAL. CONDITION: MEDIA STOP MODE
- UNLESS OTHERWISE SPECIFIED - RESISTORS ARE 1/10W ±5% METAL GLAZE RESISTOR. ALL RESISTANCE VALUES ARE IN OHM(S). ALL CAPACITORS ARE CERAMIC CAPACITOR OR MYLAR CAPACITOR. ALL CAPACITANCE VALUES ARE IN #F(=PFD). ALL INDUCTANCE VALUES ARE IN #H(=MHM). ALL E. CAPACITORS ARE SHOWN IN THE FORM OF CAPACITANCE (#F1)/RATED VOLTAGE (V). POLYPROPYLENE CAPACITOR

PARTS	NAME	REF. NO
	F41A4Z or DTC147KA	G101-G201
	F41F4M or DTC147KA	G321
	F41F4M or DTC147KA	G372

TO CN43 OF FMB-032-1

➔ TAPE P. B. SIGNAL

▲ Parts are safety assurance parts. When replacing those parts make sure to use the specified one.

TO CN44 OF FMC-029-01

5

4

3

2

1

A

B

C

2-6 D

E

F

G

■ Tuner circuit

NOTES

1. VOLTAGES ARE DC-MEASURED WITH A DIGITAL VOLT METER.
2. ALL RESISTORS ARE 1/8W ±5% METAL GLAZE RESISTOR.
3. ALL RESISTANCE VALUES ARE IN OHM(Ω).
4. ALL CAPASITANCE VALUES ARE IN nF(P=pF).
5. ALL E-CAPASITORS ARE SHOWN IN THE FORM OF CAPASITANCE (nF)/RATED VOLTAGE (V).
6. SI DIODES (D) ARE ALL 1SS133-T THAT CAN BE CHANGED TO SIMILAR DIODE SUCH AS MA165 OR HSS104J.
7. PARTS NO. OF TRANSISTORS ARE AS FOLLOWS.
Q1 2SC2814/4-5/-X Q2-Q3 2SC2412K/R/-X
Q4-Q5 DTA114YKA-X

B. INSIDE OF DIGITAL TRANSISTORS ARE SHOWN AS FOLLOWS.

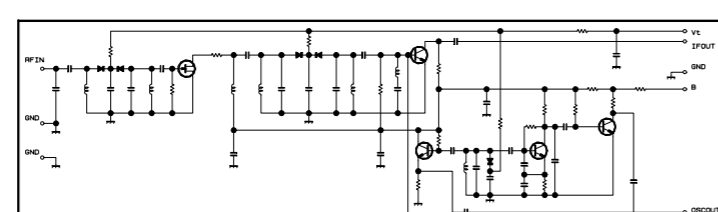
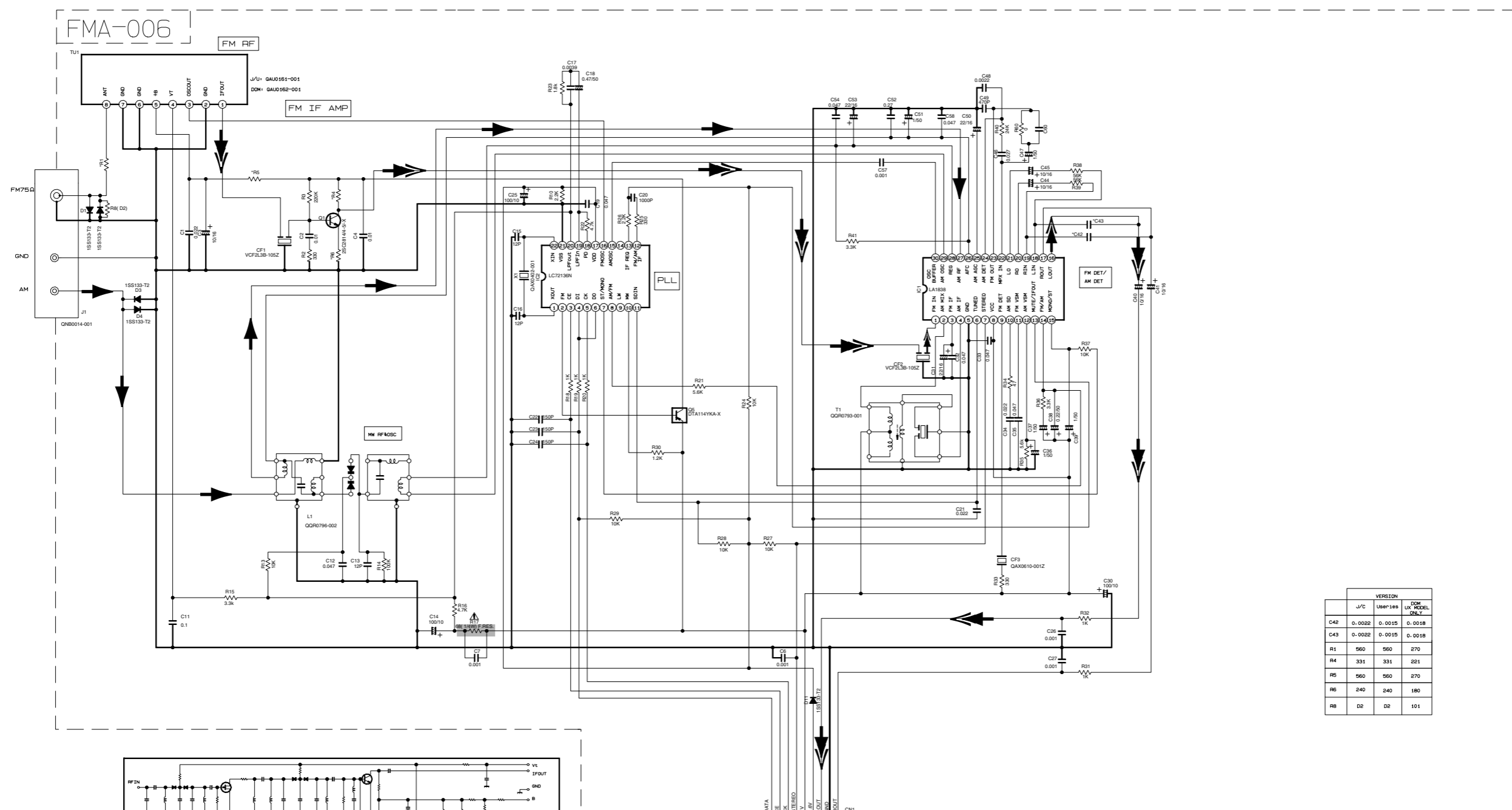
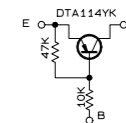

VERSION			
J/C	User188	ROM	UX MODEL
		UX	MODEL
		28.7	
C48	0.0028	0.0015	0.0018
C49	0.0022	0.0015	0.0018
R1	560	560	270
R4	331	331	221
R5	560	560	270
R6	240	240	180
R8	D2	D2	101

CONDITION	PIN NO.	1	2	3	4	5	6	7	8	9	10	11	12	13	14	15	16	17	18	19	20	21	22	23	24	25	26	27	28	29	30
IC1	FM NO SIGNAL	3.6	8.9	3.6	3.6	0	5.0	5.0	8.9	8.9	1.3	0.1	0	0.9	7.8	7.8	4.3	4.3	4.3	4.3	3.4	3.4	2.8	3.4	0	0	3.6	3.6	3.6	2.7	
	FM 60dB STEREO	3.6	8.9	3.6	3.6	0	0	5.0	8.9	8.9	1.3	4.3	0	0.9	7.8	7.8	4.3	4.3	4.3	4.3	3.4	3.4	2.8	3.4	0	0	3.6	3.6	3.6	2.7	
	AM NO SIGNAL	3.5	9.0	3.5	3.5	0	5.0	5.1	9.0	2.6	1.3	0	0	0.9	4.7	5.5	4.3	4.3	4.3	4.3	3.3	3.2	2.8	1.8	0.7	0.7	3.6	3.6	3.6	2.1	
IC2	FM NO SIGNAL	2.5	0	0	5.0	4.9	5.0	7.9	7.8	3.6	6.1	5.1	0	0	0	0	2.5	5.1	0.9	0.9	3.8	0	2.3								

Tr. NO.	Q1				Q5				
PIN NO.	E	C	B	E	C	B	E	C	B
FM 87.5MHz NO SIGNAL	0	7.1	0.85	8.9	8.8	0			
AM 522kHz NO SIGNAL	0	0	0	9.0	0	8.9			

Tr. NO.	Q2				Q3				Q4			
PIN NO.	E	C	B	E	C	B	E	C	B	E	C	B
AM 522kHz NO SIGNAL	0	0	0.7	0	0	0.7	0	3.6	0.7			
AM 144kHz NO SIGNAL	0	0	0.3	0	0.3	0.3	3.6	3.6	3.6			

➔ AM SIGNAL
➔ FM/TUNER SIGNAL

⚠ Parts are safety assurance parts. When replacing those parts make sure to use the specified one.

5
4
3
2
1

A B C D E F G 2-7

■ Mic & Head phone circuit

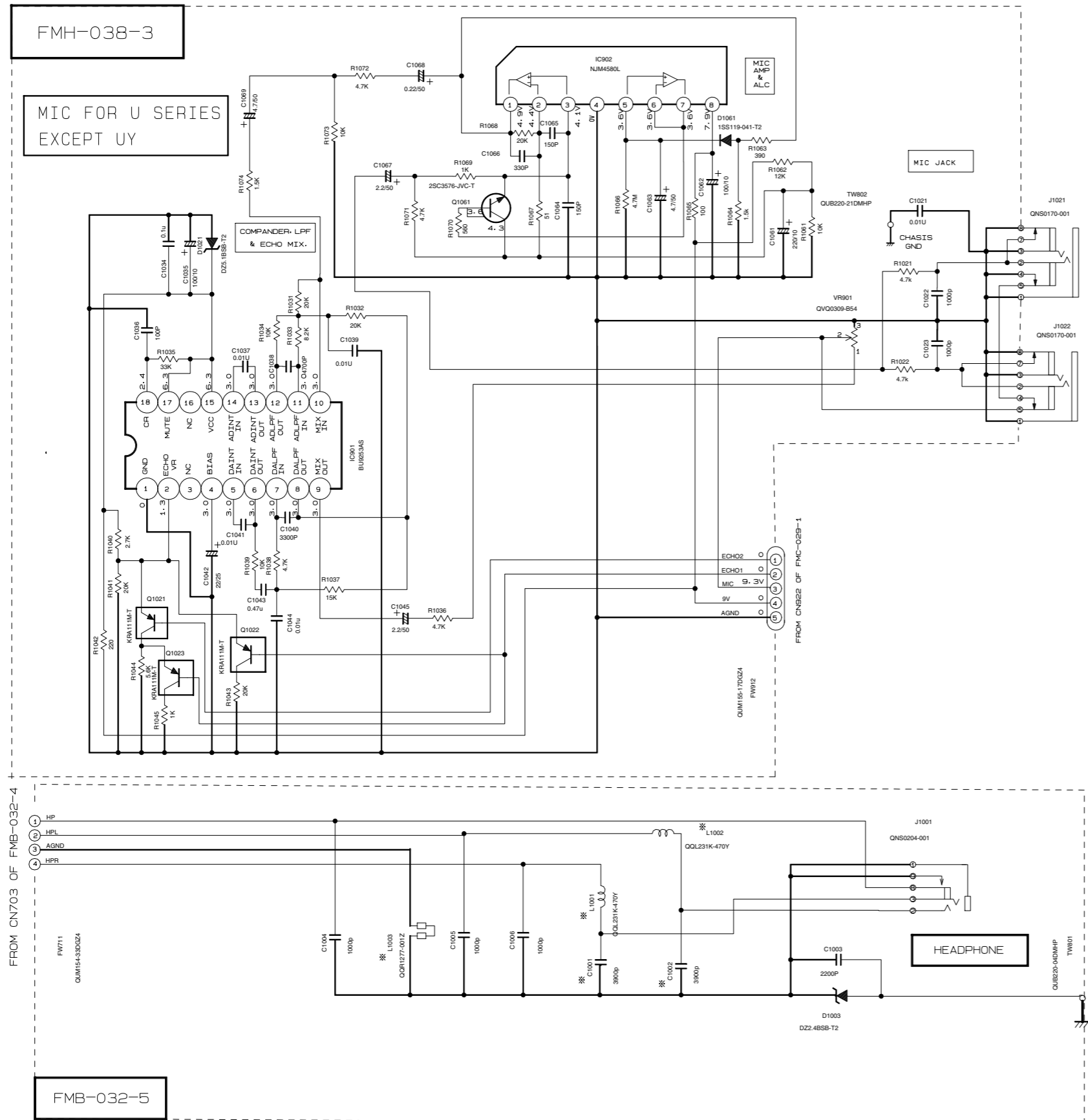

* MARK	L 1001, L 1002	C 1001, C 1002	L 1003
B, E, EN, EV	QQL231K-470Y	3900P	QQR1277-001Z
A	QQL231K-470Y	3900P	QQR1277-001Z
J, C	SHORT	NONE	QQL231K-2R2Y
U, UJ, UT, UW	SHORT	NONE	QQL231K-2R2Y
UY	SHORT	NONE	QQL231K-2R2Y

* MARK	L 1001, L 1002	C 1001, C 1002	L 1003
B, E, EN, EV	QQL231K-470Y	3900P	QQR1277-001Z
A	QQL231K-470Y	3900P	QQL231K-2R2Y
J, C	SHORT	NONE	QQL231K-2R2Y
U, UJ, UT, UW	SHORT	NONE	QQL231K-2R2Y
UY	SHORT	3900P	QQL231K-2R2Y

NOTES

- VOLTAGES ARE DC-MEASURED WITH A DIGITAL VOLT METER OR OSCILLOSCOPE WITHOUT INPUT SIGNAL. CONDITION --- AUX MODE, ECHO OFF
- UNLESS OTHERWISE SPECIFIED
RESISTORS ARE 1/4W ± 5% CARBON RESISTOR. ALL RESISTANCE VALUES ARE IN OHM (Ω). ALL CAPACITORS ARE CERAMIC CAPACITOR OR MYLAR CAPACITOR. ALL CAPACITANCE VALUES ARE IN #F (P=pF). ALL INDUCTANCE VALUES ARE IN #H (m=mH). ALL E-CAPACITORS ARE SHOWN IN THE FORM OF CAPACITANCE (F/RATED VOLTAGE (V).

■ Power supply circuit

POWER SUPPLY BLOCK

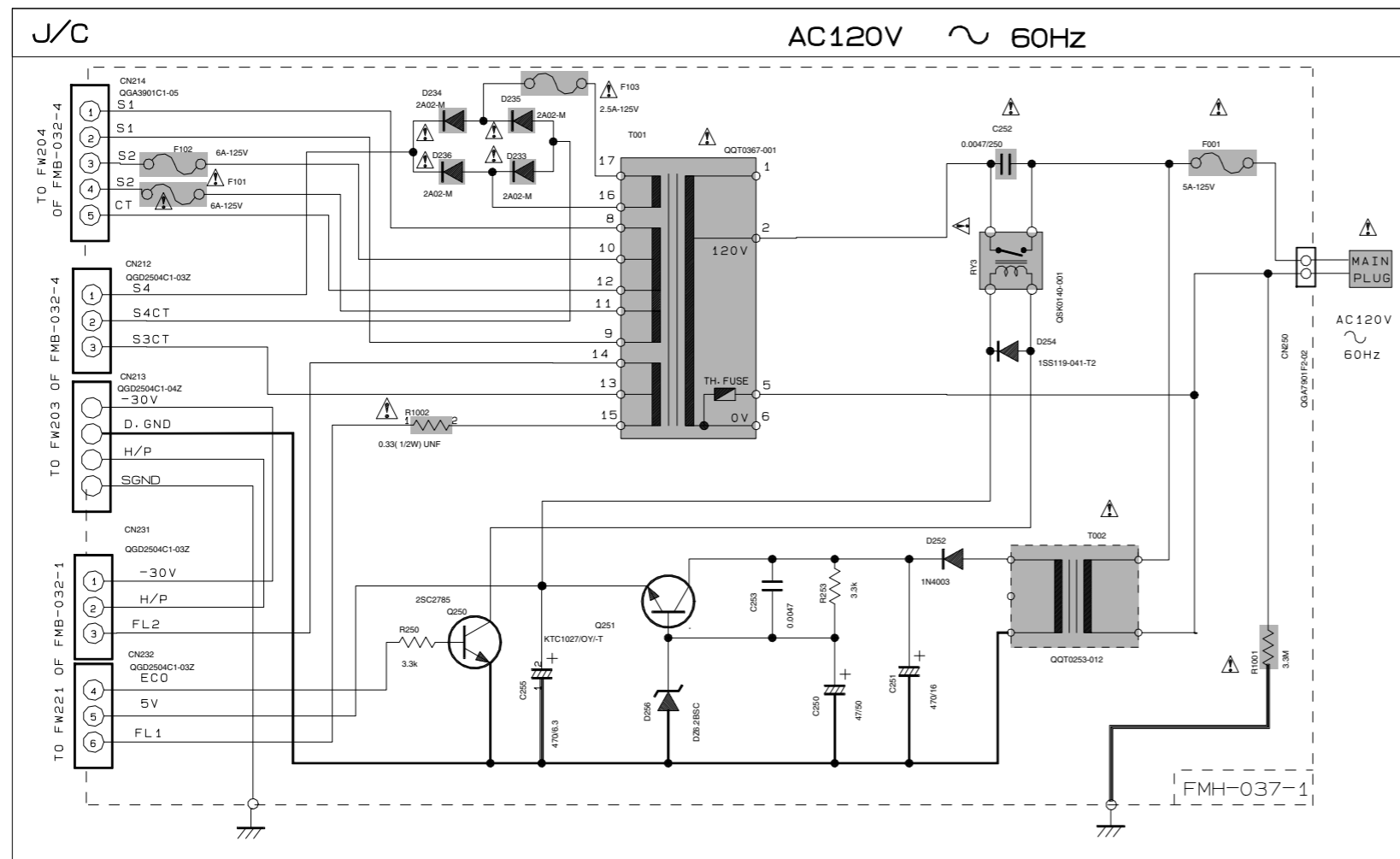

EXPLANATION OF OVERALL OF SCHEMA.
 MODEL CA-HXZ1/CA-HXZ1R/HX-Z1/HX-Z1R

SHEET NUMBER	CIRCUITS DESCRIPTION
1/9	. PRIMARY WITH MAINS TRANSFORMER
2/9	. DC REGULATORS/AUDIO OUTPUT
3/9	. EXTERNAL INPUT. SOURCE SELECTOR SWITCH
4/9	. FL DISPLAY. SYSTEM CONTROL LSI. USER CONTROL KEYS
5/9	. MIC AMP. ECHO CIRCUIT (ONLY FOR U. UJ. UT. UW)
6/9	. CD SERVO AND CD SYSTEM CONTROL . CD CHANGER MECHANISM CONTROL
7/9	. TAPE DECK MECHANISM CONTROL . TAPE CIRCUITS SUCH AS PRE-AMP AND BIAS
8/9	. TUNER RF/IF/FM MULTIPLEX (ONLY FOR A. B. E. EN. EV)
9/9	. TUNER RF/IF/FM MULTIPLEX (ONLY FOR C. J. U. UP. US. UT. UX. UY)

VERSION CODES

- J : U. S. A.
- C : CANADA
- B : U. K.
- E : CONTINENTAL EUROPE
- EN : NORDIC COUNTRIES
- EV : EASTERN EUROPE & RUSSIA
- A : AUSTRALIA
- UJ : MILITARY
- UT : TAIWAN
- UY : ARGENTINA
- UW : SOUTH AMERICA EXCEPT ARGENTINA
- U : UNIVERSAL EXCEPT ALL OF ABOVE

VOLTAGE SELECTOR LOCATION

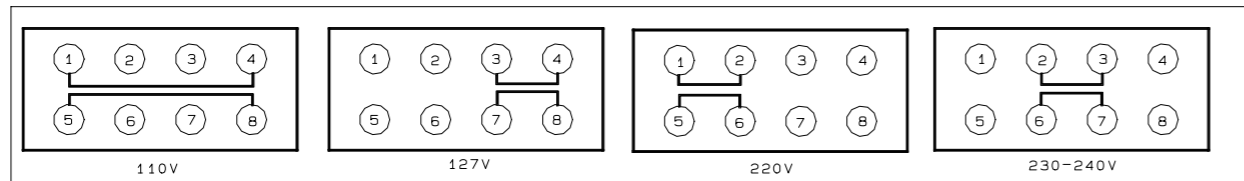

▲ Parts are safety assurance parts. When replacing those parts make sure to use the specified one.

5
4
3
2
1

Printed circuit boards

■ Main board

5

4

3

2

1

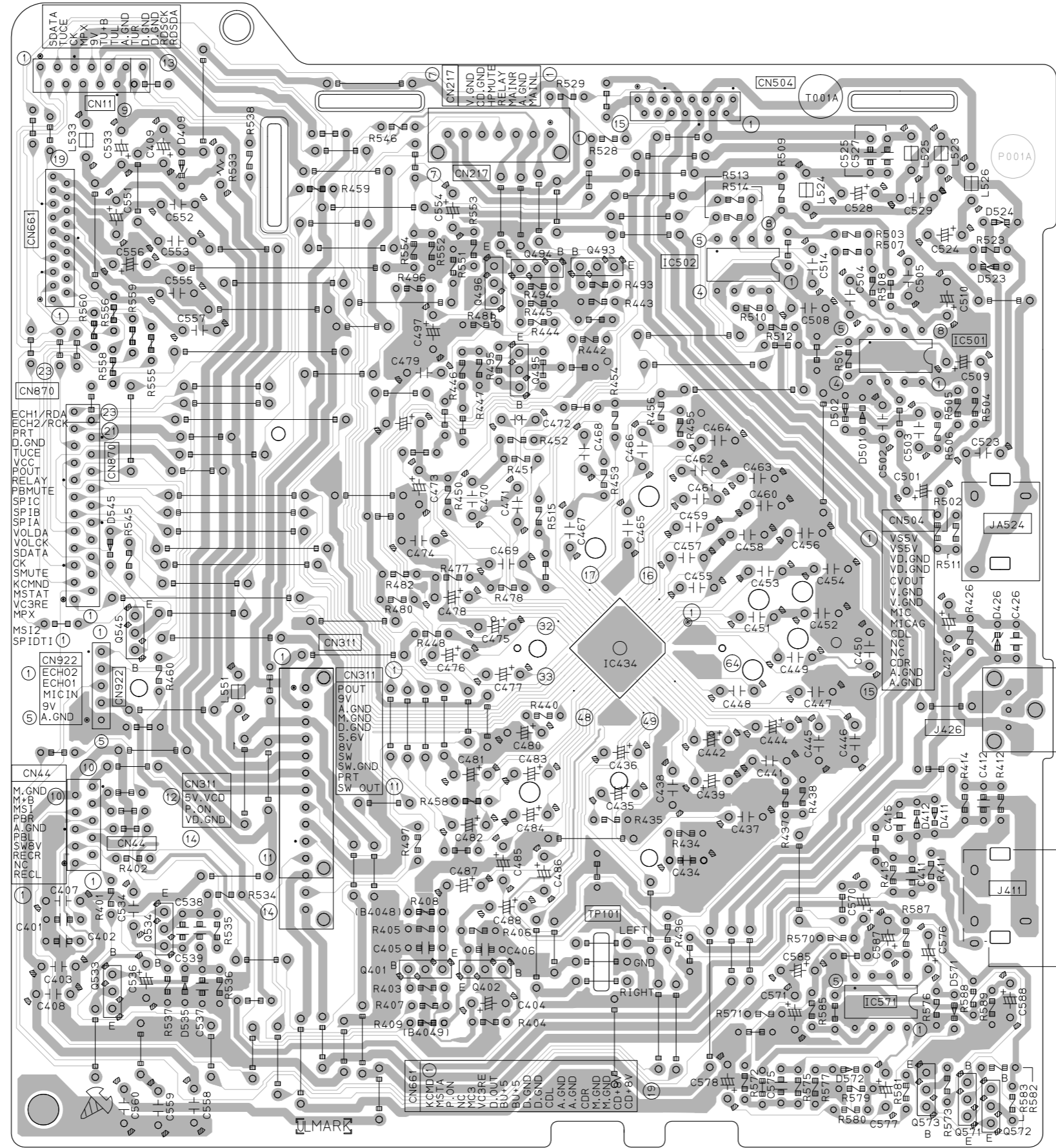

A

B

C

2-10 D

E

F

G

Front board

5

4

3

2

1

A

B

C

D

E

F

G

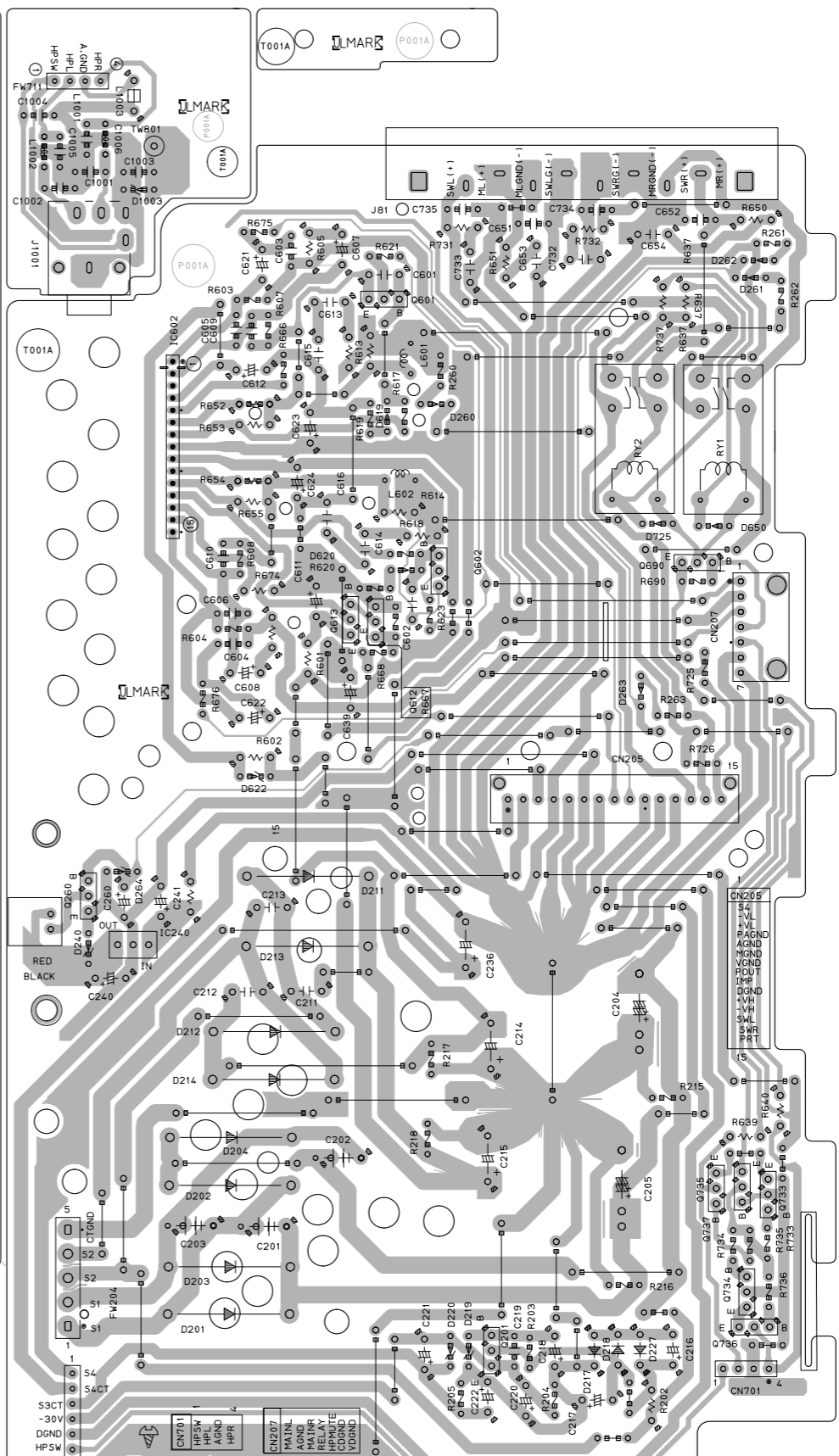
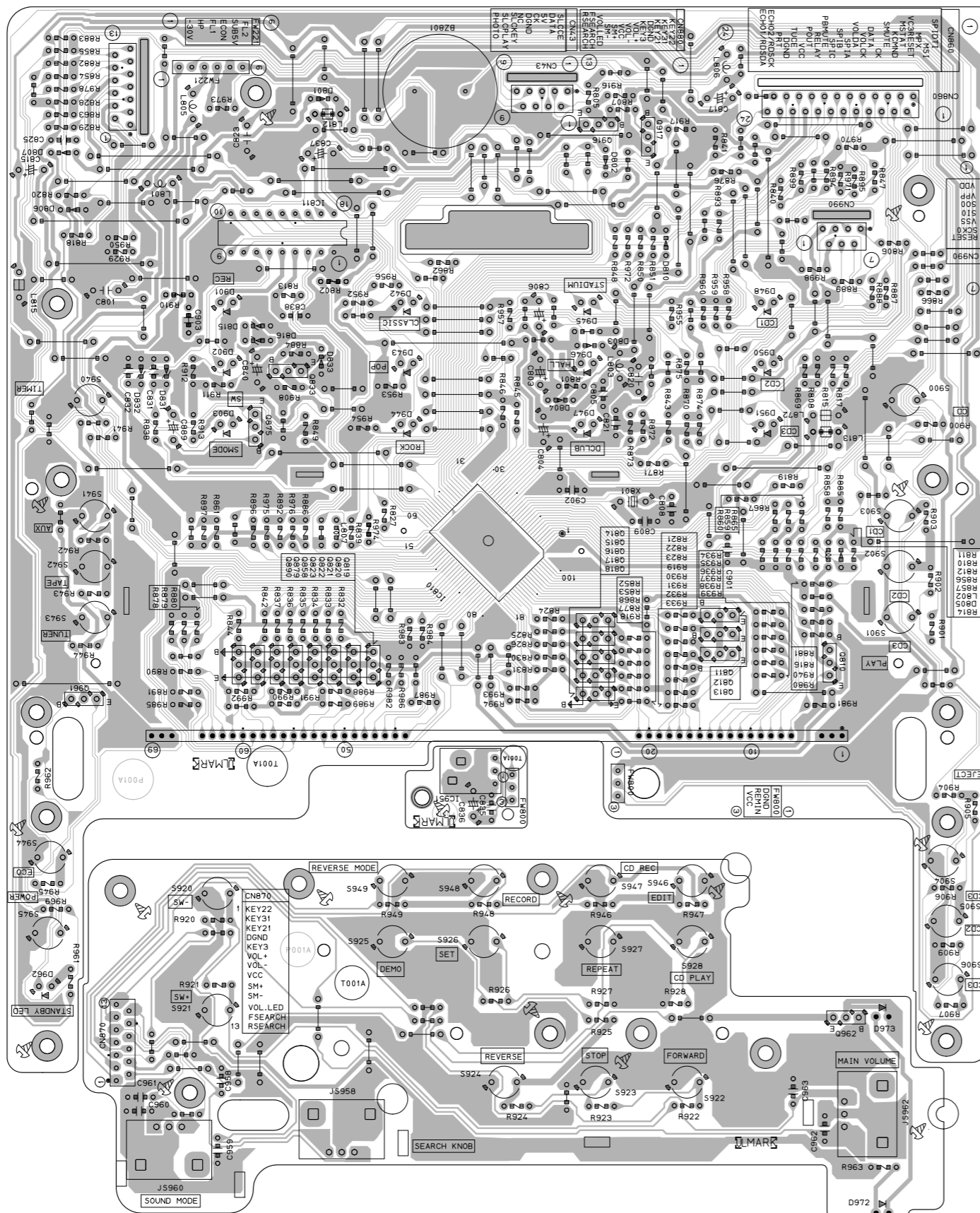

■ Power amplifier board

5

4

3

2

1

A

B

C

2-12 D

E

F

G

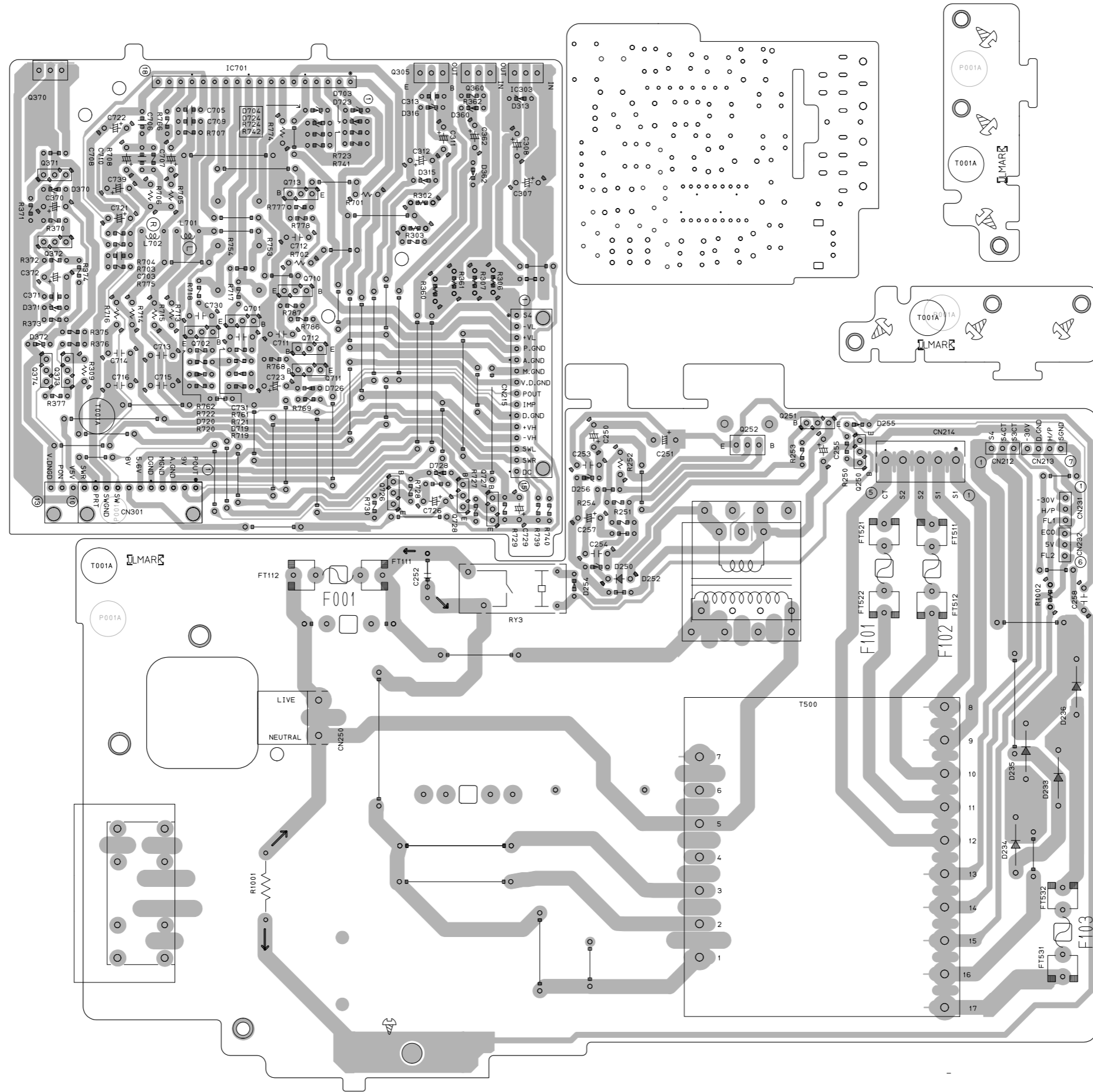

CD servo control board

5
4
3
2
1

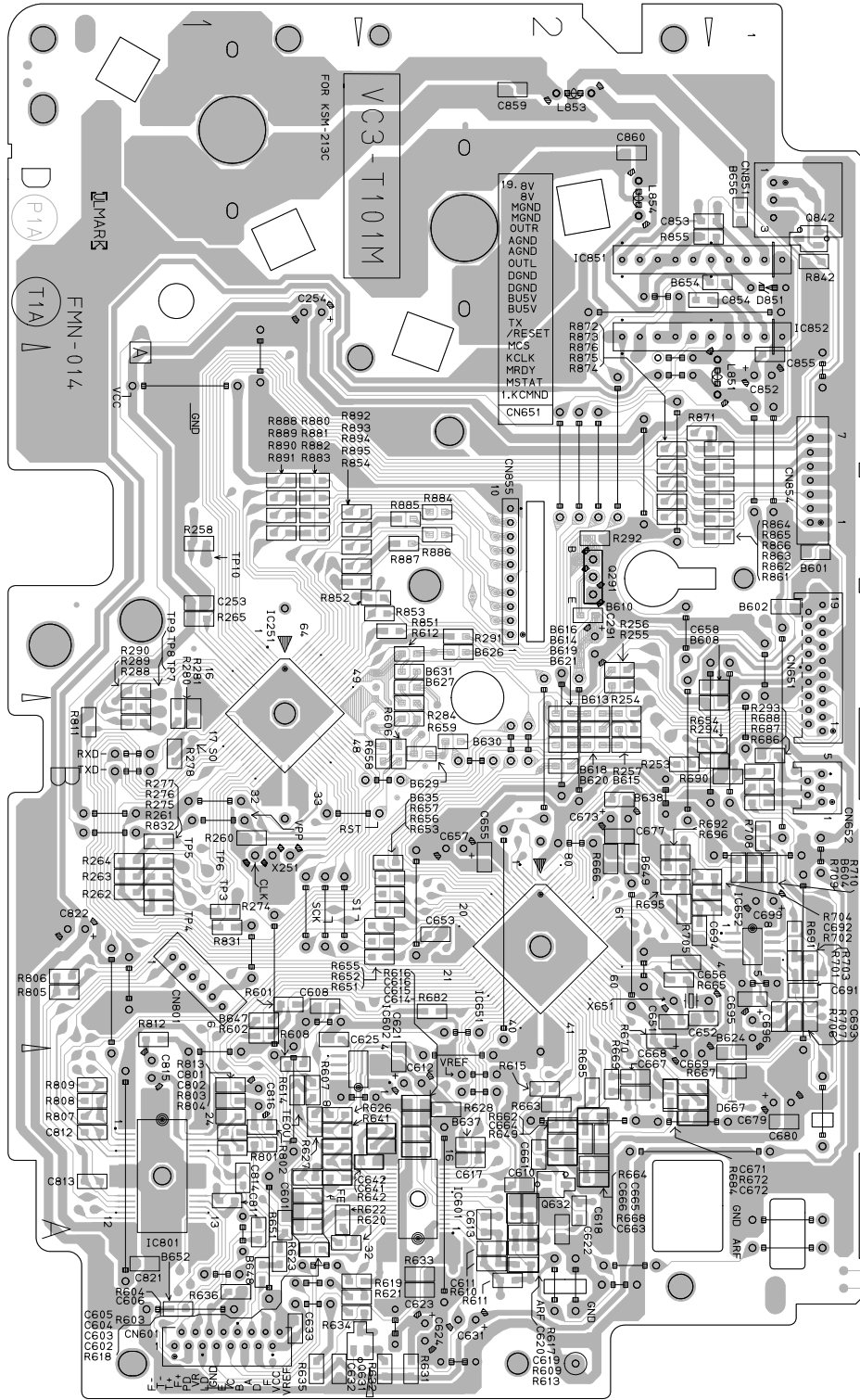

A B C 2-13

■ Tuner board

5
4
3
2
1

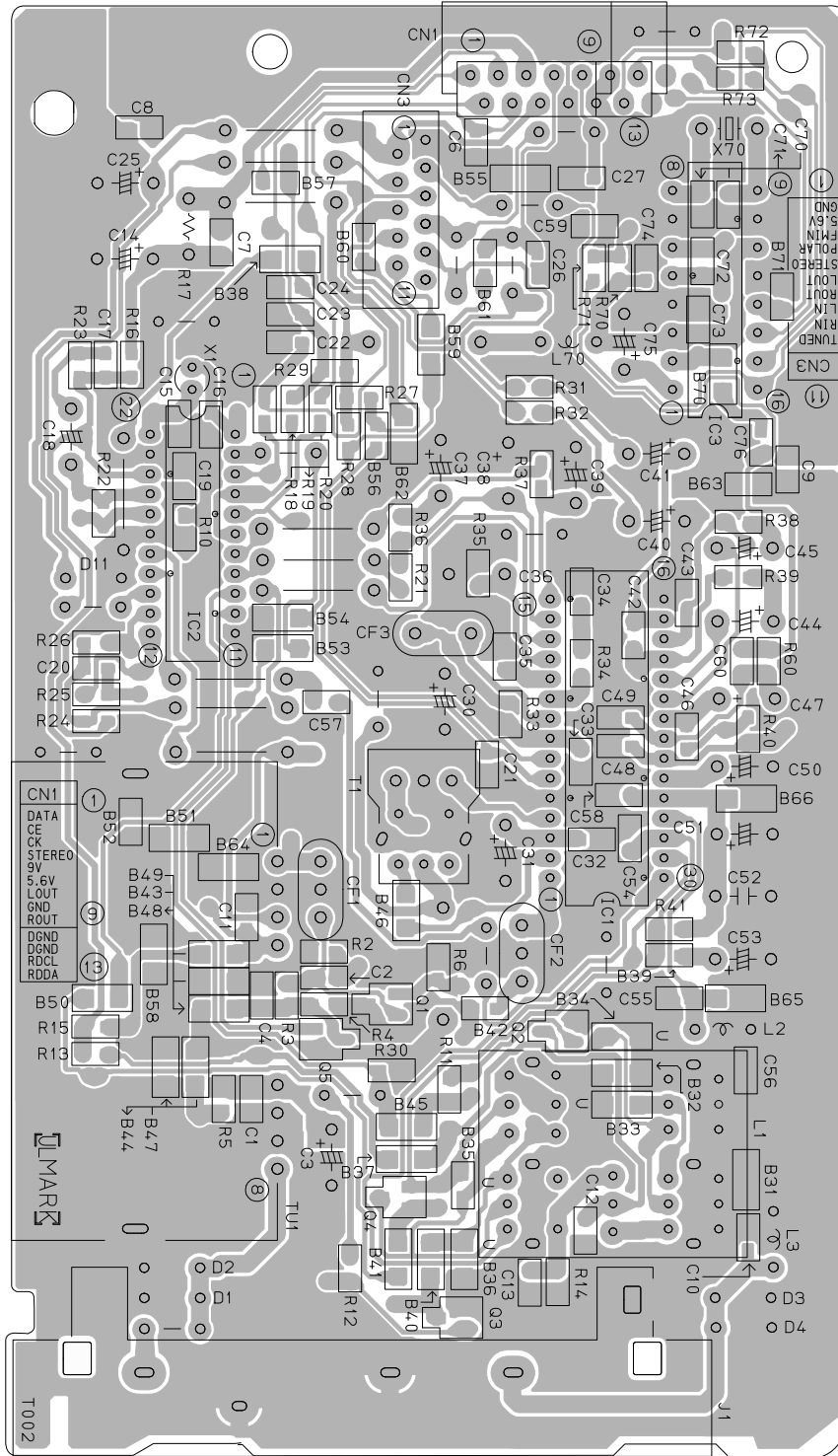

■ **Traverse mechanism board**

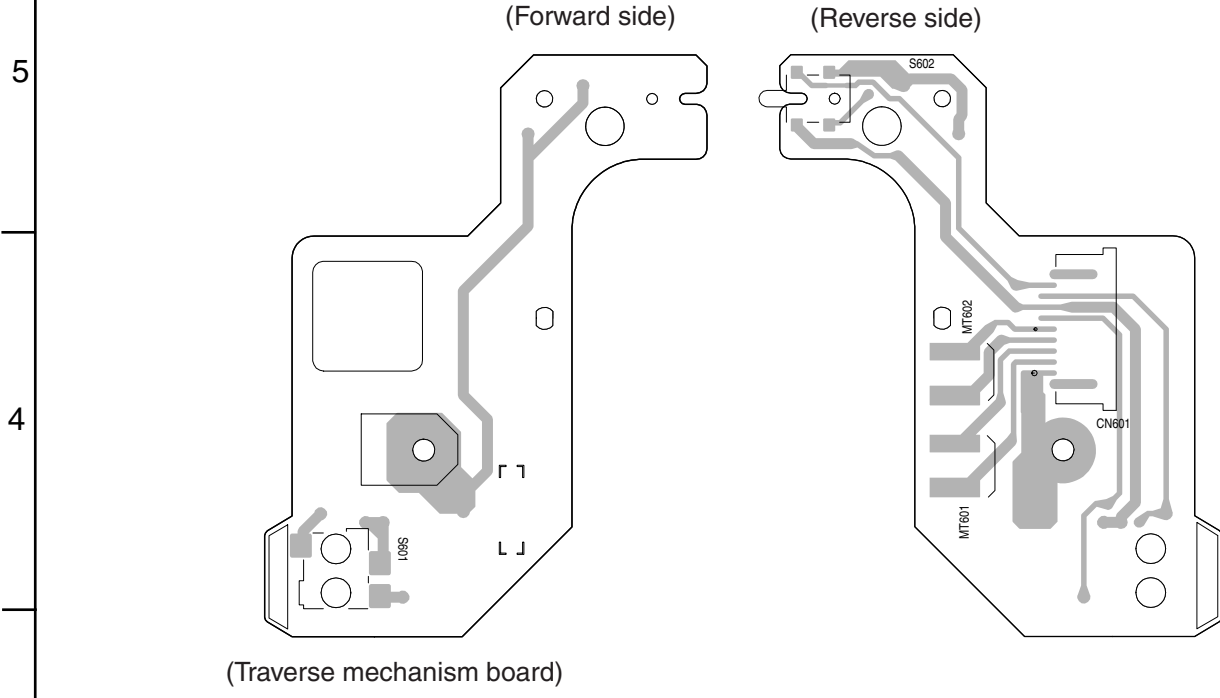

■ **Cassette switch board**

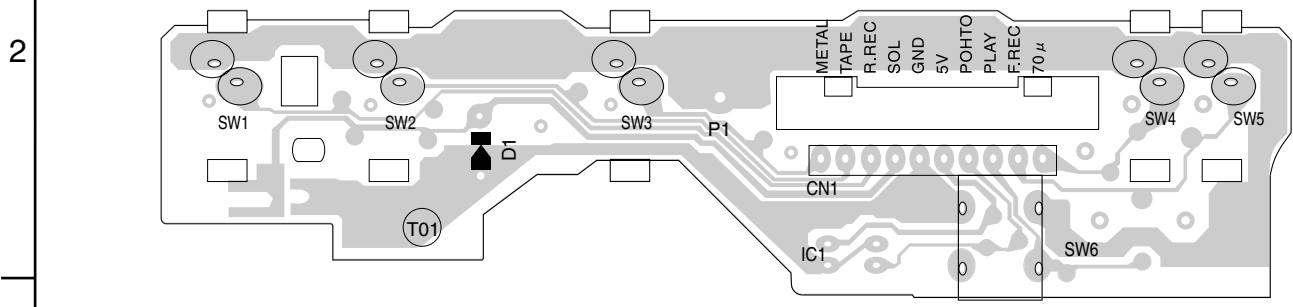



VICTOR COMPANY OF JAPAN, LIMITED
AUDIO & COMMUNICATION BUSINESS DIVISION
PERSONAL & MOBILE NETWORK BUSINESS UNIT. 10-1,1chome,Ohwatari-machi,Maebashi-city,371-8543,Japan

PARTS LIST

[HX-Z1]

* All printed circuit boards and its assemblies are not available as service parts.

Area suffix	
J	U.S.A.
C	Canada

- Contents -

Exploded view of general assembly and parts list (Block No.M1)	3- 3
Speaker assembly and parts list (Block No.M2)	3- 6
CD changer mechanism assembly and parts list (Block No.MA)	3- 8
Cassette mechanism assembly and parts list (Block No.MP)	3-10
Electrical parts list (Block No.01~08)	3-12
Packing materials and accessories parts list (Block No.M3,M5)	3-24

< M E M O >

Exploded view of general assembly and parts list

Block No. **M 1 M M**

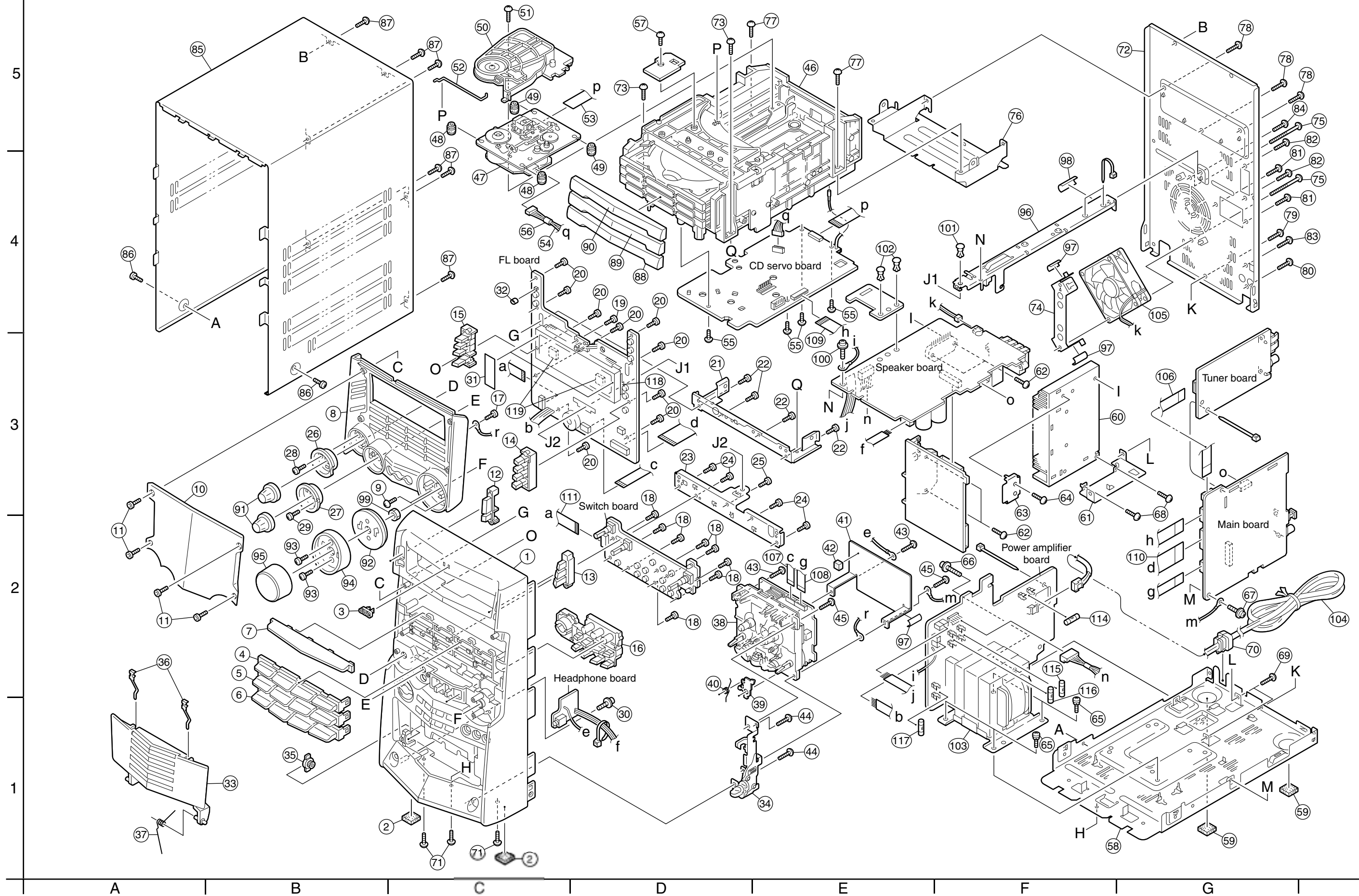

■ Parts list (General assembly)

Block No. M1MM

△	Item	Parts number	Parts name	Q'ty	Description	Area
	1	GV10115-006A	FRONT PANEL	1		
	2	GV40313-001A	FELT SPACER	2		
	3	GV40077-002A	JVC BADGE	1		
	4	GV30293-002A	FUNCTION LENS A	1		
	5	GV30294-002A	FUNCTION LENS B	1		
	6	GV30295-002A	FUNCTION LENS C	1		
	7	GV30296-001A	FL LENS	1		
	8	GV10114-002A	WINDOW FRAME	1		
	9	QYSDSF2608Z	SCREW	2	W.FRAME/F.PNL	
	10	GV20171-001A	WINDOW SCREEN	1		
	11	LV40744-001A	SOCKET BOLT	4	W.SCREEN/F.PNL	
	12	GV30309-002A	POWER BUTTON AS	1		
	13	GV30288-001A	CD EJECT BUTTON	1		
	14	GV30290-002A	CD BUTTON	1		
	15	GV30289-002A	FUNCTION BUTTON	1		
	16	GV20169-001A	CONTROL BUTTON	1		
	17	QYSDSF2608Z	SCREW	1	WIRE + W.FRAME	
	18	QYSDSF2608Z	SCREW	8	PWB BRD./F.PANE	
	19	QYSDSF2608Z	SCREW	1	REMOTE BRD./F.P	
	20	QYSDSF2608Z	SCREW	9	MICOM PWB/F.PNL	
	21	GV30082-002A	STAY BRACKET	1		
	22	QYSDSF2608Z	SCREW	4	STY.BRKT.+F.PNL	
	23	GV30301-001A	SUPPORT BRACKET	1		
	24	QYSDSF2608Z	SCREW	4	SPT.BRKT.+F.PNL	
	25	QYSDSF2608Z	SCREW	1	SPT.BRKT + F.PN	
	26	GV30303-001A	PRESET RING	1		
	27	GV30302-001A	SOUND MODE RING	1		
	28	QYSDSF2608Z	SCREW	1	PRE.RING/F.PANE	
	29	QYSDSF2608Z	SCREW	1	S.M.RING/F.PANE	
	30	E65923-003	TAPPING SCREW	1	PHONE BRD./F.PN	
	31	GV40342-001A	FL SHEET	2		
	32	GV40343-001A	VINYL TUBE	1		
	33	GV30315-001A	CASS.HOLD.ASSY.	1		
	34	GV30311-001A	EJECT SYS.ASSY.	1		
	35	GV40034-001A	DAMPER ASSY	1		
	36	VKY4180-401	CASSETTE SPRING	2		
	37	GV40317-001A	HOLDER SPRING	1		
	38	-----	CASSETTE MECHA	1	SLC-S101M	
	39	VKL7850-002	EJECT SAFTY A	1		
	40	VKW5258-003	TORSION SPRING	1	EJECT SAFETY A	
	41	GV30124-001A	TRANS SHIELD	1		
	42	GV40170-003A	SPACER	1	STICK AT SLC	
	43	QYSBSF3012Z	SCREW	2	MECHA/F.PANEL	
	44	QYSBSF3010Z	SCREW	2	E.ARM BKT./F.PL	
	45	QYSBSG3010Z	T.SCREW	2	MECHA/E.ARM BKT	
	46	-----	CD CHANGER	1	C3BASE-2M	
	47	KSM-213CCMJ	CD MECHA	1		
	48	LV42763-001A	INSULATOR	2		

■ Parts list (General assembly)

Block No. M1MM

△	Item	Parts number	Parts name	Q'ty	Description	Area
	49	LV42763-002A	INSULATOR	2		
	50	VKS3703-00R	CLAMPER	1		
	51	QYSPST2606Z	SCREW	1		
	52	VKW5187-001	ROD	1		
	53	QUQ610-1609AJ	FLAT WIRE	1		
	54	VDM1001-M002AV	SOCKET WIRE ASS	1		
	55	QYSBSF2608Z	T.SCREW	4		
	56	VYSA1R2-033	SPACER	1	FOR VDM1001-M00	
	57	QYSBSF3008Z	SCREW	1	FOR LOD STOPPER	
	58	GV10111-001A	CHASSIS BASE	1		
	59	GV40313-002A	FELT SPACER	2	CHASS BASE FOOT	
	60	GV30279-002A	HEAT SINK	1		
	61	GV30281-001A	BASE BRACKET	1		
	62	QYSBSG3014E	T.SCREW	4	FOR POWER IC	
	63	GV40297-001A	LEAF SPRING	1		
	64	QYSBSG3014E	T.SCREW	1	FOR LEAF SPRING	
	65	QYSDSTL4008Z	SPECIAL SCREW	4	FOR TRANS/CH.BS	
	66	QYSBSFG3016Z	SCREW	1	PRI.BRD/CH.BASE	
	67	QYSBSGG3008E	T.SCREW	1	FMC BRD./CH.BS	
	68	QYSBSG3014E	T.SCREW	2	BASE BRKT/H.SIN	
	69	QYSBSG3008E	T.SCREW	2	CH.BS./BS.BRKT.	
△	70	QZW0033-001	STRAIN RELIEF	1		
	71	QYSBSGY3008E	SPECIAL SCREW	3	F.PANEL/CH. BAS	
	72	GV10112-001A	REAR PANEL	1		
	73	QYSBSG3010Z	T.SCREW	2	C3 MECHA/S.BRKT	
	74	GV30278-001A	FAN BARCKET	1		
	75	QYSBSGY3008E	SPECIAL SCREW	2	R.PANEL/FAN.BRK	
	76	GV30277-001A	REAR BRACKET	1		
	77	QYSBSG3010Z	T.SCREW	2	R.BRKT./CD MECH	
	78	QYSBSGY3008E	SPECIAL SCREW	3	R.BRKT./R.PANEL	
	79	QYSBSGY3008E	SPECIAL SCREW	1	REAR PNL/CHAS.B	
	80	QYSBSGY3008E	SPECIAL SCREW	1	REAR PNL/ AUX	
	81	QYSBSGY3008E	SPECIAL SCREW	2	SPK/ REAR PANEL	
	82	QYSBSGY3008E	SPECIAL SCREW	2	TUNER/REAR PANE	
	83	QYSBSGY3008E	SPECIAL SCREW	1	OPTICAL/R.PANEL	
	84	QYSBSGY3008E	SPECIAL SCREW	1	INNER BAR/R.PNL	
	85	GV10110-001A/S/	METAL COVER	1		
	86	QYSDSG3006M	T.SCREW	2	M.COVER/C.BASE	
	87	QYSBSGY3008E	SPECIAL SCREW	6	M.COVER/R.PANEL	
	88	GV20166-001A	CD FITTING 1	1	DISC 1	
	89	GV20167-001A	CD FITTING 2	1	DISC 2	
	90	GV20168-001A	CD FITTING 3	1	DISC 3	
	91	GV30299-001A	SD. MODE KNOB	2		
	92	GV30297-002A	VOLUME LENS	1		
	93	QYSDSF2608Z	SCREW	2	VOL.LEN/F.PANEL	
	94	GV30262-002A	VOLUME ORNAMENT	1		
	95	GV30298-001A	VOLUME KNOB	1		
	96	GV30286-001A	INNER BAR	1		

■ Parts list (General assembly)

Block No. M1MM

⚠	Item	Parts number	Parts name	Q'ty	Description	Area
	97	GV40121-004A	SPACER	3		
	98	LV30225-079A	SPACER	1	STICK AT I.BAR	
	99	GV40186-001A	NUT	1		
	100	QYSBSGG3008E	T.SCREW	1	INNER BAR/FMH B	
	101	E310243-002	PLASTIC RIVET	1	SUPP.BRKT./INNE	
	102	E310243-002	PLASTIC RIVET	2	HOLD.BRD./FMH B	
⚠	103	QQT0367-001	POWER TRANSF	1	T001	
⚠	104	QMPD330-200-JD	POWER CORD	1		
	105	QAR0228-001	FAN MOTOR	1		
	106	QUQH12-0907BJ	FLAT WIRE	1	FC 1	
	107	QUQH12-0908BJ	FLAT WIRE	1	FC 33	
	108	QUQH12-1023BJ	FLAT WIRE	1	FC 34	
	109	QUQH10-1918AJ	FLAT WIRE	1	FC651	
	110	QUQH12-2120BJ	FLAT WIRE	1	FC860	
	111	QUQH12-1309BJ	FLAT WIRE	1	FC880	
⚠	114	QMF51U1-5R0-J8	FUSE	1	F001	
⚠	115	QMF51U1-6R0-J8	FUSE	1	F101	
⚠	116	QMF51U1-6R0-J8	FUSE	1	F102	
⚠	117	QMF51U1-2R5-J8	FUSE	1	F103	
	118	GV30280-001A	FL HOLDER	1		
	119	E3400-439	FELT SPACER	2		

Speaker assembly and parts list

Block No. M 2 M M

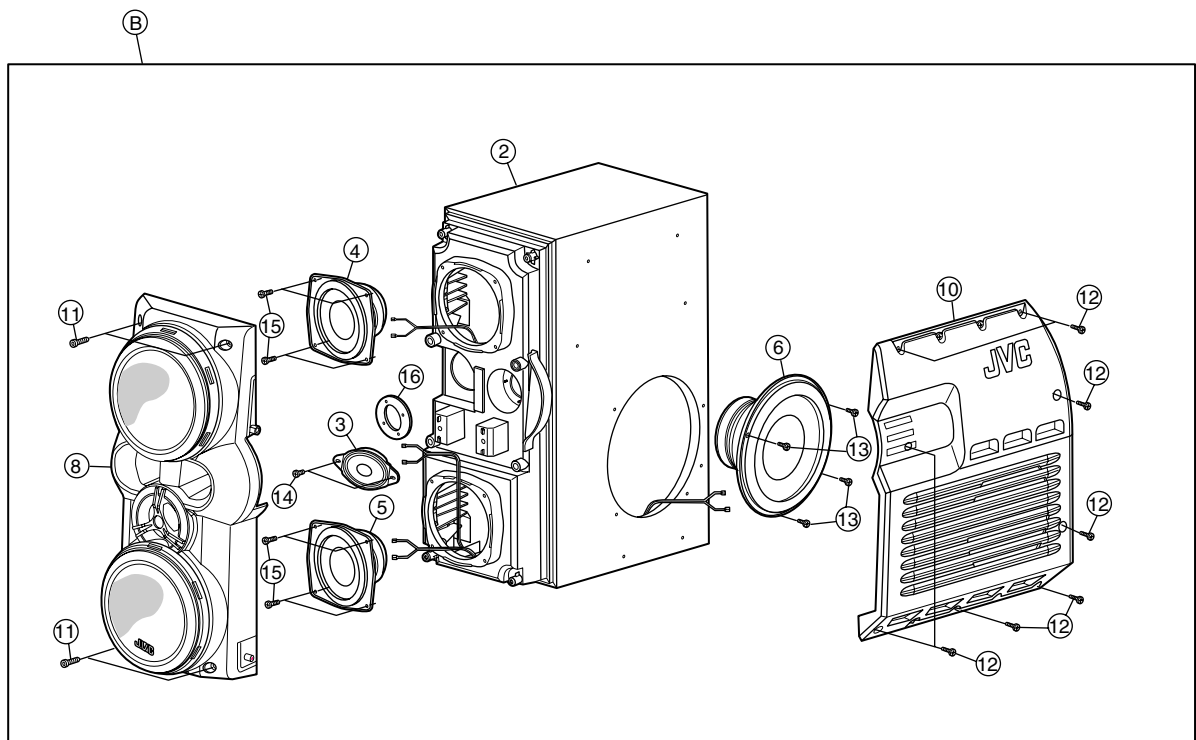
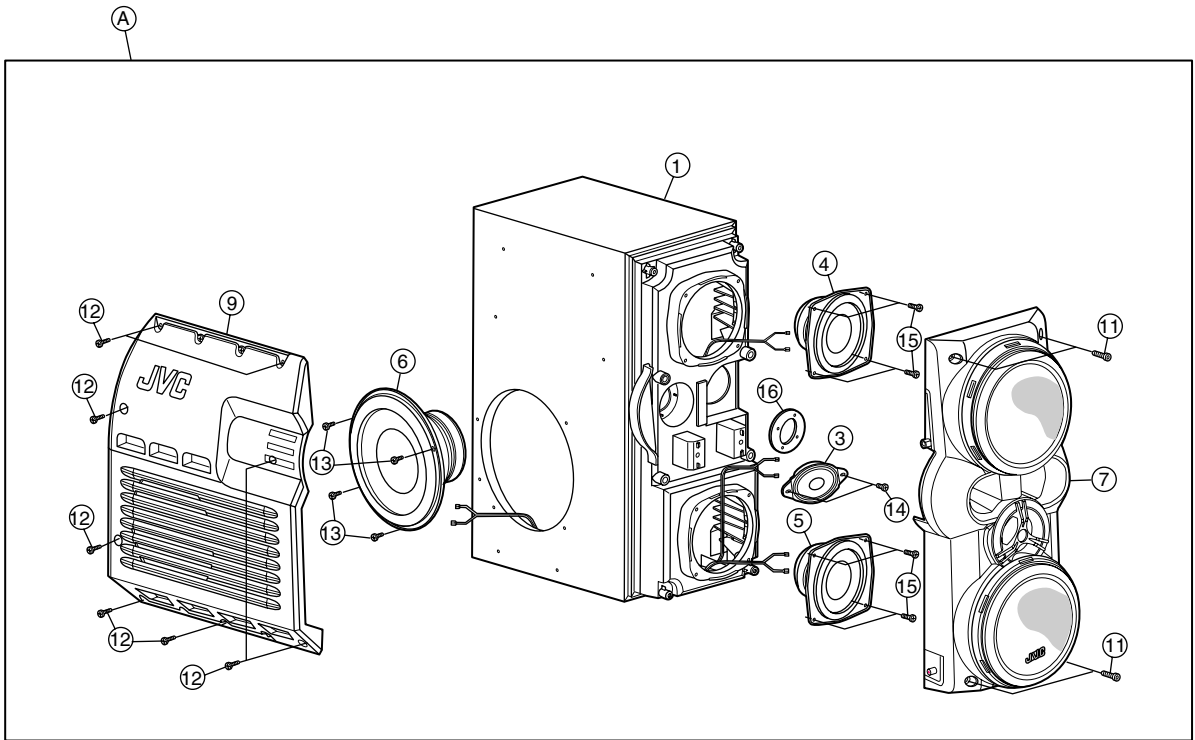

■ Parts list (Speaker assembly)

Block No. M2MM

⚠	Item	Parts number	Parts name	Q'ty	Description	Area
	A	HXZ1K-SPBOX-L	SP BOX ASSY(L)	1		
	B	HXZ1K-SPBOX-R	SP BOX ASSY(R)	1		
	1	-----	CABINET ASSY(L)	1		
	2	-----	CABINET ASSY(R)	1		
	3	993060500030	5CM TWEETER	2		
	4	991091000047	10CM WOOFER TOP	2	FOR TOP SIDE	
	5	991081000048	10CM WOOFER BOT	2	FOR BOTTOM SIDE	
	6	991061650046	16CM SUBWOOFER	2		
	7	199734300149	FRONT PANEL(L)	1		
	8	199734300150	FRONT PANEL(R)	1		
	9	151733601104	SIDE PANEL(L)	1		
	10	151733601105	SIDE PANEL(R)	1		
	11	135604161053	SCREW(M4X16)	8	FOR FRONT PANEL	
	12	135604201054	SCREW(M4X20)	16	FOR SIDE PANEL	
	13	135604201046	SCREW(M4X20)	8	FOR SUBWOOFER	
	14	135604121055	SCREW(M4X12)	4	FOR TWEETER	
	15	135604161047	SCREW(M4X16)	16	FOR WOOFER	
	16	109760511072	FOAM GASKET	2		

CD changer mechanism assembly and parts list

Block No. M A M M

Grease ★ = EM-30L
 ● = EBS0006-009B
 ▲ = FL-7750E

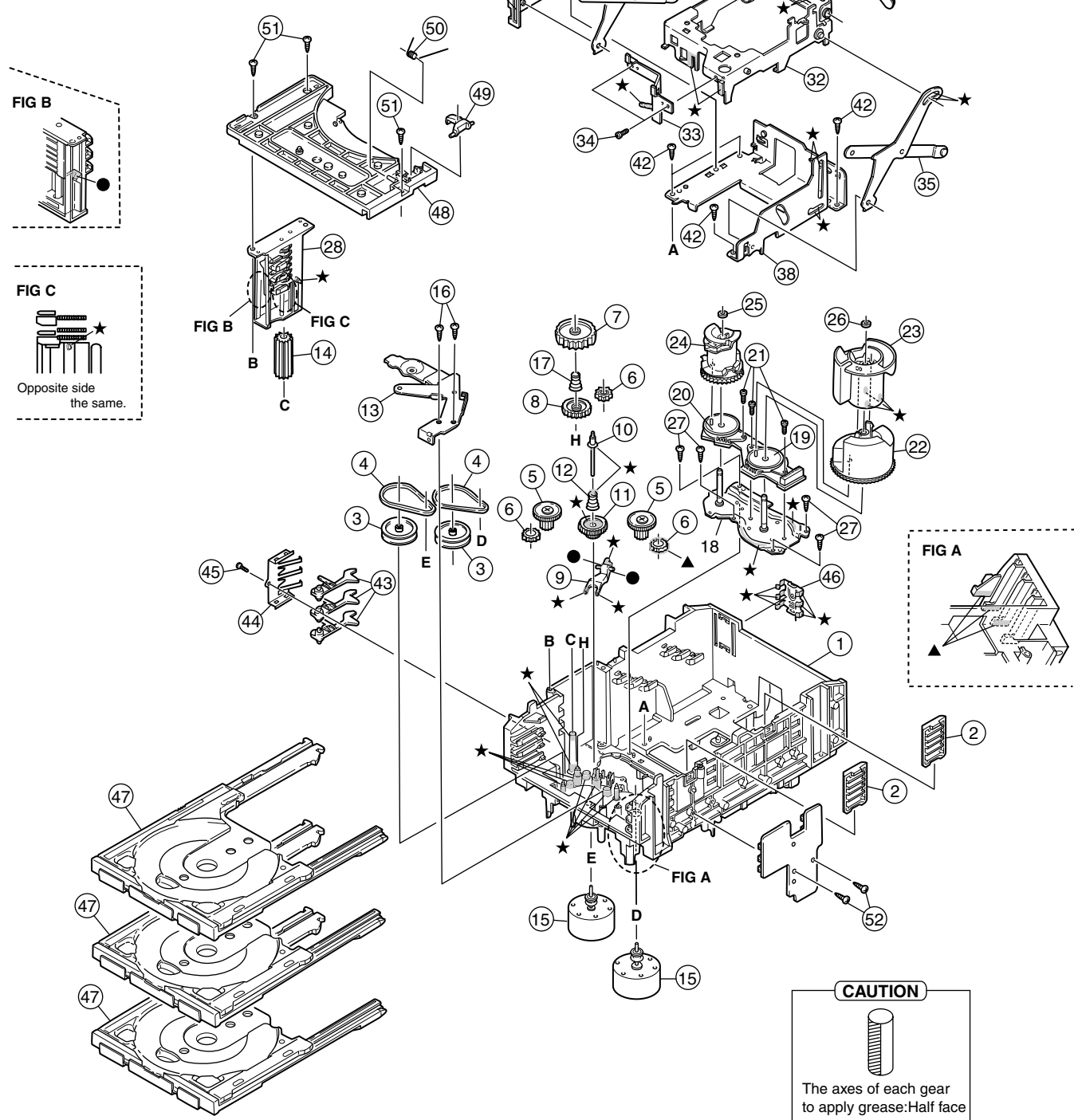

■ Parts list (CD changer mechanism)

Block No. MAMM

△	Item	Parts number	Parts name	Q'ty	Description	Area
	1	VKS1144-004	CHASSIS	1		
	2	VKS3698-003	TRAY GUIDE	2		
	3	VKS5532-003	PULLEY GEAR	2		
	4	VKB3000-164	BELT	2		
	5	VKS5505-003	GEAR B	2		
	6	VKS5506-002	GEAR C	3		
	7	VKS5507-002	CROSS GEAR U	1		
	8	VKS5508-002	CROSS GEAR L	1		
	9	VKS5510-003	SELECT LEVER	1		
	10	VKH5769-001	S.G.SHAFT	1		
	11	VKS5511-002	SELECT GEAR	1		
	12	VKW5155-003	COMP.SPRING	1	FOR SELECT GEAR	
	13	VKM3846-003	GEAR BRACKET	1		
	14	VKS5509-002MM	CYLINDER GEAR	1		
	15	MSN5D257A-SA2	DC MOTOR ASSY	2		
	16	QYSPSPD2616Z	SCREW	2	FOR MOTOR	
	17	LV40612-001A	COMP.SPRING	1		
	18	VKM3825-00B	C.G.BASE ASS'Y	1		
	19	VKZ3172-00ASS	CAM SW. R ASS'Y	1		
	20	VKZ3173-00ASS	CAM SW. L ASS'Y	1		
	21	QYSPST2606Z	SCREW	3	FOR CAM SW.	
	22	VKS2263-002MM	CAM R1	1		
	23	VKS2264-002MM	CAM R2	1		
	24	VKS2265-002MM	CAM GEAR L	1		
	25	WDL316050MM	SLIT WASHER	1	FOR CAM GEAR L	
	26	WDL316050MM	SLIT WASHER	1		
	27	QYSBSF2608Z	T.SCREW	4	FOR C.GEAR BASE	
	28	VKS3702-00FMM	DRIVE UNIT	1		
	29	VKS2247-005	MECHA HOLDER A	1		
	30	VKL7767-00F	BRACKET ASS'Y	1		
	31	QYSBSF2606Z	SCREW	2	FOR BRACKET	
	32	VKM3860-00E	M.HOLDER B AS'Y	1		
	33	VKL7802-00D	M.HOLDER C AS'Y	1		
	34	QYSDST2604Z	SCREW	2	FOR M.HOLDER C	
	35	VKL7810-00B	LIFTER ASS'Y R	1		
	36	VKL7811-00B	LIFTER ASS'Y L	1		
	37	VKL7812-00B	LIFTER ASS'Y H	1		
	38	VKL2745-003	LIFTER BASE	1		
	39	VKM3857-002	LIFTER BRACKET	1		
	40	QYSDST2604Z	SCREW	1		
	41	WDL266035-2	SLIT WASHER	1		
	42	QYSBSF2608Z	T.SCREW	4		
	43	VKS5514-002MM	LOCK LEVER	3		
	44	VKY3133-002MM	RETURN SPRING	1		
	45	QYSBSF2608Z	T.SCREW	1	FOR RETURN SP.	
	46	VKY3134-003MM	CLICK SPRING	1		
	47	VKS2252-00N	TRAY ASS'Y	3		
	48	VKS2250-004	TOP BRACKET	1		
	49	VKS5515-002	S.TRAY STOPPER	1		
	50	VKW5156-004	TORSION SPRING	1		
	51	QYSBSF2608Z	T.SCREW	3		
	52	QYSBSF2608Z	T.SCREW	2		

Cassette mechanism assembly and parts list

Block No. M P M M

SLC-S101M

Grease

- ★ =EM-30L
- ▲ =UD-24
- =UD-24H2
- =LEN-320M
- =JC-888B
- ◎ =MOBIL-1

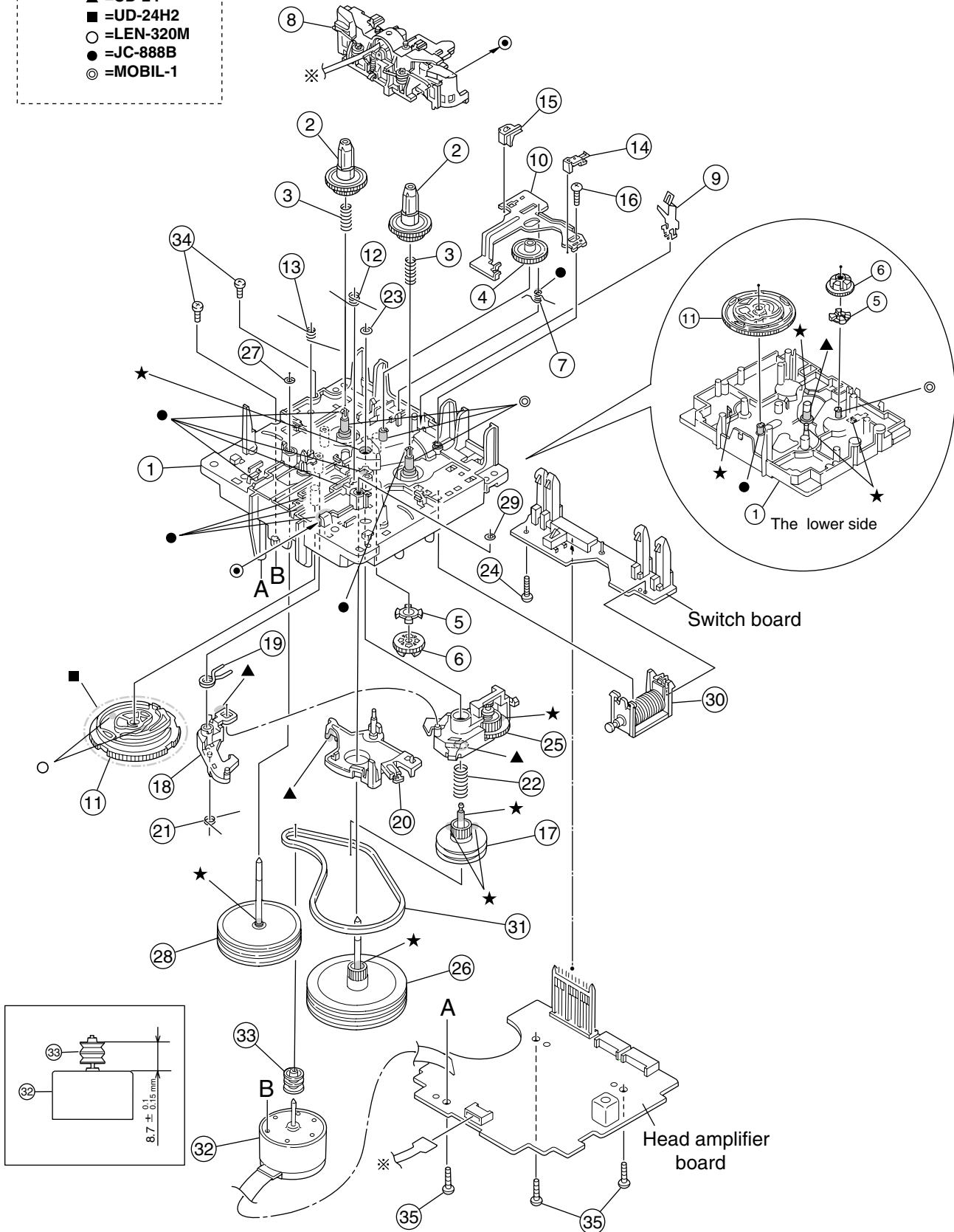

Parts list (Cassette mechanism)

Block No. MPMM

△	Item	Parts number	Parts name	Q'ty	Description	Area
	1	VKS1165-00J	CHASSIS B.ASS'Y	1		
	2	VKS2274-002	REEL GEAR	2		
	3	VKW5286-002	B.T. SPRING	2		
	4	VKS5559-001	PLAY IDLE GEAR	1		
	5	VKS5595-002	BLIND	1		
	6	VKS5560-003	FR IDLE GEAR	1		
	7	LV42013-001A	EARTH SPRING	1		
	8	SLC-RP3SVM	HEAD MOUNT	1		
	9	VKY3149-002	CASSETTE SP.	1		
	10	LV31786-001A	PLAY SW LEVER	1		
	11	VKS1166-004	CONTROL CAM	1		
	12	VKW5279-002	HEAD BASE SP(R)	1		
	13	VKW5280-001	HEAD BASE SP(L)	1		
	14	LV41584-001A	BRAKE(R)	1		
	15	LV41585-002A	BRAKE(L)	1		
	16	QYSBSF2005Z	T.SCREW	1		
	17	VKS5603-00G	MAIN PULLEY ASY	1		
	18	VKS3785-001MM	FR ARM	1		
	19	VKW5284-002	SWING SPRING	1		
	20	VKS2278-003	TRIGGER ARM	1		
	21	VKW5301-001	FR SPRING	1		
	22	VKW5266-001	ELEVATOR SPRING	1		
	23	WDL214025	WASHER	1		
	24	QYSBSF2005Z	T.SCREW	1		
	25	VKS3786-00G	CLUTCH ASS'Y	1		
	26	VKF3205-00B	F.WHEEL ASSY(R)	1		
	27	WDL183425	SLIT WASHER	1		
	28	VKF3207-00B	F.WHEEL ASSY(L)	1		
	29	WDL173525-6	SLIT WASHER	1		
	30	VKZ3174-00A	DC SOLENOID	1		
	31	LV42836-001A	CAPSTAN BELT	1		
	32	MSI-5U2LWA	D.C.MOTOR ASS'Y	1		
	33	VKR4761-001	MOTOR PULLEY	1		
	34	QYSPSP2604Z	SCREW	2		
	35	QYSBSF2608Z	T.SCREW	3	FOR P.W.B.	

Electrical parts list (Power amplifier board) Block No. 01

△	Item	Parts number	Parts name	Remarks	Area	△	Item	Parts number	Parts name	Remarks	Area
	C 250	QETN1HM-476Z	E CAPACITOR	47MF 20% 50V		△	FT521	QNG0003-001Z	FUSE CLIP		
	C 251	QETN1CM-477Z	E CAPACITOR	470MF 20% 16V		△	FT522	QNG0003-001Z	FUSE CLIP		
	C 252	QCZ9105-472	C CAPACITOR	4700PF		△	FT531	QNG0003-001Z	FUSE CLIP		
	C 253	QFLM1HJ-472Z	M CAPACITOR	4700PF 5% 50V		△	FT532	QNG0003-001Z	FUSE CLIP		
	C 255	QETN0JM-477Z	E CAPACITOR	470MF 20% 6.3V		△	IC303	KIA7808API	IC		
	C 308	QETN1HM-106Z	E CAPACITOR	10MF 20% 50V		△	IC360	KIA7805API	IC		
	C 311	QTE1V06-106Z	E CAPACITOR			△	IC701	STK412-010	IC(HYBRID)		
	C 312	QETN1HM-106Z	E CAPACITOR	10MF 20% 50V			L 701	QQLZ035-R39	INDUCTOR		
	C 313	QDGB1HK-103Y	C CAPACITOR				L 702	QQLZ035-R39	INDUCTOR		
	C 362	QETN1HM-106Z	E CAPACITOR	10MF 20% 50V			Q 250	2SC2785/FE/-T	TRANSISTOR		
	C 703	QCBB1HK-471Y	C CAPACITOR	470PF 10% 50V			Q 251	KTC1027/OY/-T	TRANSISTOR		
	C 705	QCBB1HK-221Y	C CAPACITOR	220PF 10% 50V		△	Q 305	KTC2026/Y/	SI.TRANSISTOR		
	C 706	QCBB1HK-221Y	C CAPACITOR	220PF 10% 50V			Q 701	KTA1268/GL/-T	TRANSISTOR		
	C 707	QETN1JM-476Z	E CAPACITOR	47MF 20% 63V			Q 702	KTA1268/GL/-T	TRANSISTOR		
	C 708	QETN1JM-476Z	E CAPACITOR	47MF 20% 63V			Q 710	KTA1023/OY/-T	TRANSISTOR		
	C 709	QCSB1HK-4R7Y	C CAPACITOR	4.7PF 10% 50V			Q 711	KTC3200/GL/-T	TRANSISTOR		
	C 710	QCSB1HK-4R7Y	C CAPACITOR	4.7PF 10% 50V			Q 712	KTA1268/GL/-T	TRANSISTOR		
	C 711	QFZ0212-104Z	MM CAPACITOR	.10MF			Q 713	KTC1027/OY/-T	TRANSISTOR		
	C 712	QFZ0212-104Z	MM CAPACITOR	.10MF			Q 726	KTC3200/GL/-T	TRANSISTOR		
	C 713	QFLM1HJ-473Z	M CAPACITOR	.047MF 5% 50V			Q 727	KTA1268/GL/-T	TRANSISTOR		
	C 714	QFLM1HJ-473Z	M CAPACITOR	.047MF 5% 50V			Q 728	2SC2785/FE/-T	TRANSISTOR		
	C 715	QFLM1HJ-473Z	M CAPACITOR	.047MF 5% 50V			R 250	QRE141J-332Y	C RESISTOR	3.3K 5% 1/4W	
	C 716	QFLM1HJ-473Z	M CAPACITOR	.047MF 5% 50V			R 251	QRE141J-332Y	C RESISTOR	3.3K 5% 1/4W	
	C 721	QETN1CM-476Z	E CAPACITOR	47MF 20% 16V			R 253	QRE141J-332Y	C RESISTOR	3.3K 5% 1/4W	
	C 722	QETN1CM-476Z	E CAPACITOR	47MF 20% 16V			R 254	QRE141J-153Y	C RESISTOR	15K 5% 1/4W	
	C 723	QETN1AM-107Z	E CAPACITOR	100MF 20% 10V			R 304	QRE141J-103Y	C RESISTOR	10K 5% 1/4W	
	C 726	QETN1EM-106Z	E CAPACITOR	10MF 20% 25V		△	R 305	QRJ146J-2R2X	UNF C RESISTOR	2.2 5% 1/4W	
	C 729	QETN1CM-476Z	E CAPACITOR	47MF 20% 16V		△	R 307	QRJ146J-1R0X	UNF C RESISTOR	1.0 5% 1/4W	
	C 730	FQCF31HZ-223Z	D CAPACITOR				R 362	QRE141J-102Y	C RESISTOR	1.0K 5% 1/4W	
	C 731	FQCF31HZ-223Z	D CAPACITOR			△	R 701	QRJ146J-470X	UNF C RESISTOR	47 5% 1/4W	
	C 739	QETN1HM-105Z	E CAPACITOR	1.0MF 20% 50V		△	R 702	QRJ146J-470X	UNF C RESISTOR	47 5% 1/4W	
	CN212	QGD2504C1-03Z	SOCKET				R 703	QRE141J-563Y	C RESISTOR	56K 5% 1/4W	
	CN213	QGD2504C1-04Z	SOCKET				R 704	QRE141J-563Y	C RESISTOR	56K 5% 1/4W	
	CN214	QGA3901C1-05	CONNECTOR			△	R 705	FQRJ143J-821X	UNF C RESISTOR		
	CN215	QGB2510K2-15	CONNECTOR			△	R 706	FQRJ143J-821X	UNF C RESISTOR		
	CN231	QGD2504C1-03Z	SOCKET				R 707	QRE141J-563Y	C RESISTOR	56K 5% 1/4W	
	CN232	QGD2504C1-03Z	SOCKET				R 708	QRE141J-563Y	C RESISTOR	56K 5% 1/4W	
	CN250	QGA7901F2-02	CONNECTOR			△	R 713	QRJ146J-100X	UNF C RESISTOR	10 5% 1/4W	
	CN301	QGB2510K2-11	CONNECTOR			△	R 714	QRJ146J-100X	UNF C RESISTOR	10 5% 1/4W	
△	D 233	2A02-M	DIODE			△	R 715	FQRJ143J-100X	UNF C RESISTOR		
△	D 234	2A02-M	DIODE			△	R 716	FQRJ143J-100X	UNF C RESISTOR		
△	D 235	2A02-M	DIODE				R 717	QRE141J-102Y	C RESISTOR	1.0K 5% 1/4W	
△	D 236	2A02-M	DIODE				R 718	QRE141J-102Y	C RESISTOR	1.0K 5% 1/4W	
	D 252	1N4003S-T5	SI DIODE				R 719	QRE141J-562Y	C RESISTOR	5.6K 5% 1/4W	
	D 254	1SS119-041-T2	SI DIODE				R 720	QRE141J-562Y	C RESISTOR	5.6K 5% 1/4W	
	D 256	DZ6.2BSC-T2	ZENER DIODE				R 721	QRE141J-103Y	C RESISTOR	10K 5% 1/4W	
	D 313	DZ10BSC-T2	Z.DIODE				R 722	QRE141J-103Y	C RESISTOR	10K 5% 1/4W	
	D 315	DZ11BSC-T2	ZENER DIODE				R 723	QRE141J-103Y	C RESISTOR	10K 5% 1/4W	
	D 316	DZ10BSC-T2	Z.DIODE				R 724	QRE141J-103Y	C RESISTOR	10K 5% 1/4W	
	D 360	1SS119-041-T2	SI DIODE				R 727	QRE141J-104Y	C RESISTOR	100K 5% 1/4W	
	D 362	DZ8.2BSC-T2	Z.DIODE				R 728	QRE141J-103Y	C RESISTOR	10K 5% 1/4W	
	D 703	DZ15BSC-T2	ZENER DIODE				R 729	QRE141J-104Y	C RESISTOR	100K 5% 1/4W	
	D 704	DZ15BSC-T2	ZENER DIODE				R 730	QRE141J-103Y	C RESISTOR	10K 5% 1/4W	
	D 719	1SS119-041-T2	SI DIODE				R 739	QRE141J-823Y	C RESISTOR	82K 5% 1/4W	
	D 720	1SS119-041-T2	SI DIODE				R 740	QRE141J-104Y	C RESISTOR	100K 5% 1/4W	
	D 723	DZ36BSA-T2	ZENER DIODE				R 741	QRE141J-103Y	C RESISTOR	10K 5% 1/4W	
	D 724	DZ36BSA-T2	ZENER DIODE				R 742	QRE141J-103Y	C RESISTOR	10K 5% 1/4W	
	D 726	1SS119-041-T2	SI DIODE				R 753	QRZ0197-R22	C RESISTOR	5W	
	D 728	1SS119-041-T2	SI DIODE				R 754	QRZ0197-R22	C RESISTOR	5W	
△	FT111	QNG0003-001Z	FUSE CLIP				R 761	QRE141J-102Y	C RESISTOR	1.0K 5% 1/4W	
△	FT112	QNG0003-001Z	FUSE CLIP				R 762	QRE141J-102Y	C RESISTOR	1.0K 5% 1/4W	
△	FT511	QNG0003-001Z	FUSE CLIP				R 766	QRE141J-333Y	C RESISTOR	33K 5% 1/4W	
△	FT512	QNG0003-001Z	FUSE CLIP				R 768	QRE141J-104Y	C RESISTOR	100K 5% 1/4W	

■ Electrical parts list (Power amplifier board) Block No. 01

△	Item	Parts number	Parts name	Remarks	Area
	R 769	QRE141J-222Y	C RESISTOR	2.2K 5% 1/4W	
△	R 774	QRJ146J-100X	UNF C RESISTOR	10 5% 1/4W	
	R 775	QRE141J-102Y	C RESISTOR	1.0K 5% 1/4W	
	R 777	QRE141J-103Y	C RESISTOR	10K 5% 1/4W	
	R 778	QRE141J-103Y	C RESISTOR	10K 5% 1/4W	
	R 786	QRE141J-103Y	C RESISTOR	10K 5% 1/4W	
	R 787	QRE141J-103Y	C RESISTOR	10K 5% 1/4W	
△	RY 3	QSK0140-001	RELAY		
△	R1001	QRZ9037-335	F RESISTOR	3.3M 1/2W	
△	R1002	ERX12SJR33E	UNF.C.RESISTOR		
△	T 002	QQT0253-012	POWER TRANS		

■ Electrical parts list (Main board)

Block No. 02

△	Item	Parts number	Parts name	Remarks	Area	△	Item	Parts number	Parts name	Remarks	Area
	C 401	QCBB1HK-221Y	C CAPACITOR	220PF 10% 50V			C 502	QFLM1HJ-153Z	M CAPACITOR	.015MF 5% 50V	
	C 402	QCBB1HK-221Y	C CAPACITOR	220PF 10% 50V			C 503	QFVJ1HJ-224Z	MF CAPACITOR	.22MF 5% 50V	
	C 403	FQCF31HP-103Z	C CAPACITOR				C 504	QFLM1HJ-822Z	M CAPACITOR	8200PF 5% 50V	
	C 404	QETN1CM-476Z	E CAPACITOR	47MF 20% 16V			C 505	QFVJ1HJ-274Z	MF CAPACITOR	.27MF 5% 50V	
	C 407	QFLM1HJ-223Z	M CAPACITOR	.022MF 5% 50V			C 508	QFLM1HJ-273Z	M CAPACITOR	.027MF 5% 50V	
	C 409	QETN0JM-107Z	E CAPACITOR	100MF 20% 6.3V			C 509	QETN1HM-475Z	E CAPACITOR	4.7MF 20% 50V	
	C 411	QCBB1HK-221Y	C CAPACITOR	220PF 10% 50V			C 510	QETN1AM-107Z	E CAPACITOR	100MF 20% 10V	
	C 412	QCBB1HK-221Y	C CAPACITOR	220PF 10% 50V			C 514	QFLC1HJ-471Z	M CAPACITOR	470PF 5% 50V	
	C 415	QDXB1CM-222Y	C CAPACITOR				C 533	QETN1AM-107Z	E CAPACITOR	100MF 20% 10V	
	C 426	QDVB1EZ-223Y	C CAPACITOR				C 534	QFLM1HJ-153Z	M CAPACITOR	.015MF 5% 50V	
	C 427	QETN1EM-106Z	E CAPACITOR	10MF 20% 25V			C 536	QETN1HM-105Z	E CAPACITOR	1.0MF 20% 50V	
	C 435	QETN1EM-106Z	E CAPACITOR	10MF 20% 25V			C 537	QDGB1HK-681Y	C CAPACITOR		
	C 436	QETN1EM-106Z	E CAPACITOR	10MF 20% 25V			C 538	QDXB1CM-182Y	C CAPACITOR		
	C 437	QFLM1HJ-104Z	M CAPACITOR	.10MF 5% 50V			C 539	QCSB1HJ-330Y	C CAPACITOR	33PF 5% 50V	
	C 438	QFLM1HJ-473Z	M CAPACITOR	.047MF 5% 50V			C 551	QETN1AM-227Z	E CAPACITOR	220MF 20% 10V	
	C 442	QETN1EM-106Z	E CAPACITOR	10MF 20% 25V			C 552	QFLM1HJ-104Z	M CAPACITOR	.10MF 5% 50V	
	C 444	QETN1EM-106Z	E CAPACITOR	10MF 20% 25V			C 553	QFLM1HJ-103Z	M CAPACITOR	.010MF 5% 50V	
	C 445	QFLM1HJ-104Z	M CAPACITOR	.10MF 5% 50V			C 554	QETN1EM-106Z	E CAPACITOR	10MF 20% 25V	
	C 446	QFLM1HJ-472Z	M CAPACITOR	4700PF 5% 50V			C 555	QFLM1HJ-103Z	M CAPACITOR	.010MF 5% 50V	
	C 447	QFVJ1HJ-224Z	MF CAPACITOR	.22MF 5% 50V			C 556	QETN1EM-106Z	E CAPACITOR	10MF 20% 25V	
	C 448	QFVJ1HJ-224Z	MF CAPACITOR	.22MF 5% 50V			C 557	QFLM1HJ-104Z	M CAPACITOR	.10MF 5% 50V	
	C 449	QFVJ1HJ-224Z	MF CAPACITOR	.22MF 5% 50V			C 559	FQCF31HP-103Z	C CAPACITOR		
	C 450	QFVJ1HJ-224Z	MF CAPACITOR	.22MF 5% 50V			C 560	QFLM1HJ-223Z	M CAPACITOR	.022MF 5% 50V	
	C 451	QFLM1HJ-104Z	M CAPACITOR	.10MF 5% 50V			C 570	QETN1JM-476Z	E CAPACITOR	47MF 20% 63V	
	C 452	QFLM1HJ-104Z	M CAPACITOR	.10MF 5% 50V			C 571	QETN1HM-225Z	E CAPACITOR	2.2MF 20% 50V	
	C 453	QFLM1HJ-104Z	M CAPACITOR	.10MF 5% 50V			C 575	QCBB1HK-101Y	C CAPACITOR	100PF 10% 50V	
	C 454	QFLM1HJ-104Z	M CAPACITOR	.10MF 5% 50V			C 576	QETN1CM-476Z	E CAPACITOR	47MF 20% 16V	
	C 455	QFLM1HJ-223Z	M CAPACITOR	.022MF 5% 50V			C 577	QETN1CM-476Z	E CAPACITOR	47MF 20% 16V	
	C 456	QFLM1HJ-223Z	M CAPACITOR	.022MF 5% 50V			C 578	QETN1HM-105Z	E CAPACITOR	1.0MF 20% 50V	
	C 457	QFLM1HJ-223Z	M CAPACITOR	.022MF 5% 50V			C 585	QETN1HM-476Z	E CAPACITOR	47MF 20% 50V	
	C 458	QFLM1HJ-223Z	M CAPACITOR	.022MF 5% 50V			C 587	QETN1CM-107Z	E CAPACITOR	100MF 20% 16V	
	C 459	QFLM1HJ-103Z	M CAPACITOR	.010MF 5% 50V			C 588	QETN1AM-227Z	E CAPACITOR	220MF 20% 10V	
	C 460	QFLM1HJ-103Z	M CAPACITOR	.010MF 5% 50V			CN 11	QGF1205F1-09	CONNECTOR		
	C 461	QFLM1HJ-103Z	M CAPACITOR	.010MF 5% 50V			CN 44	QGF1201F3-10	CONNECTOR		
	C 462	QFLM1HJ-103Z	M CAPACITOR	.010MF 5% 50V			CN217	QGB2510J1-07	CONNECTOR		
	C 463	QFG32AJ-222Z	PP CAPACITOR	2200PF 5% 100V			CN311	QGB2510J1-11	CONNECTOR		
	C 464	QFG32AJ-222Z	PP CAPACITOR	2200PF 5% 100V			CN661	QGF1036F1-19	FFC/FPC CONNE		
	C 465	QFG32AJ-223Z	PP CAPACITOR	.022MF 5% 100V			CN870	QGF1205F1-21	CONNECTOR		
	C 466	QFG32AJ-223Z	PP CAPACITOR	.022MF 5% 100V			D 409	DZ5.1BSB-T2	ZENER DIODE		
	C 467	QFG32AJ-223Z	PP CAPACITOR	.022MF 5% 100V			D 411	1SS119-041-T2	SI DIODE		
	C 468	QFG32AJ-223Z	PP CAPACITOR	.022MF 5% 100V			D 412	1SS119-041-T2	SI DIODE		
	C 469	QFLM1HJ-104Z	M CAPACITOR	.10MF 5% 50V			D 426	DZ5.1BSB-T2	ZENER DIODE		
	C 470	QFLM1HJ-104Z	M CAPACITOR	.10MF 5% 50V			D 448	1SS119-041-T2	SI DIODE		
	C 471	QFLM1HJ-104Z	M CAPACITOR	.10MF 5% 50V			D 501	1SS119-041-T2	SI DIODE		
	C 472	QFLM1HJ-104Z	M CAPACITOR	.10MF 5% 50V			D 502	1SS119-041-T2	SI DIODE		
	C 473	QETN1EM-227Z	E CAPACITOR	220MF 20% 25V			D 535	1SS119-041-T2	SI DIODE		
	C 474	QFVJ1HJ-394Z	MF CAPACITOR	.39MF 5% 50V			D 545	1SS119-041-T2	SI DIODE		
	C 475	QETN1AM-477Z	E CAPACITOR	470MF 20% 10V			D 571	1SS119-041-T2	SI DIODE		
	C 476	QTE1V06-106Z	E CAPACITOR				D 572	1SS119-041-T2	SI DIODE		
	C 477	QTE1V06-106Z	E CAPACITOR				IC434	BH3874AKS2	IC		
	C 478	QTE1C06-476Z	E CAPACITOR				IC501	NJM4580D	IC		
	C 479	QFVJ1HJ-224Z	MF CAPACITOR	.22MF 5% 50V			IC502	NJM4580D	IC		
	C 480	QETN1HM-106Z	E CAPACITOR	10MF 20% 50V			IC571	NJM4580D	IC		
	C 481	QTE1V06-106Z	E CAPACITOR				J 411	QNN0420-001	PIN JACK		
	C 482	QTE1V06-106Z	E CAPACITOR				J 426	GP1FA550TZ	OPT TRANSMITTER		
	C 483	QETN1EM-106Z	E CAPACITOR	10MF 20% 25V			L 533	QQR1277-001Z	F.BEADS		
	C 484	QETN1EM-106Z	E CAPACITOR	10MF 20% 25V			L 551	QQR1277-001Z	F.BEADS		
	C 485	QETN1EM-106Z	E CAPACITOR	10MF 20% 25V			Q 401	2SC3576-JVC-T	TRANSISTOR		
	C 486	QETN1EM-106Z	E CAPACITOR	10MF 20% 25V			Q 402	2SC3576-JVC-T	TRANSISTOR		
	C 487	QETN1HM-225Z	E CAPACITOR	2.2MF 20% 50V			Q 493	2SC3576-JVC-T	TRANSISTOR		
	C 488	QETN1HM-225Z	E CAPACITOR	2.2MF 20% 50V			Q 494	2SC3576-JVC-T	TRANSISTOR		
	C 497	QETN1HM-105Z	E CAPACITOR	1.0MF 20% 50V			Q 495	2SC3576-JVC-T	TRANSISTOR		
	C 501	QETN1HM-475Z	E CAPACITOR	4.7MF 20% 50V			Q 496	KRA102M-T	D.TRANSISTOR		

■ Electrical parts list (Main board)

Block No. 02

△	Item	Parts number	Parts name	Remarks	Area	△	Item	Parts number	Parts name	Remarks	Area
	Q 533	2SC2785/FE/-T	TRANSISTOR				R 535	QRE141J-225Y	C RESISTOR	2.2M 5% 1/4W	
	Q 534	2SC2785/FE/-T	TRANSISTOR				R 536	QRE141J-104Y	C RESISTOR	100K 5% 1/4W	
	Q 545	KRA102M-T	D.TRANSISTOR				R 537	QRE141J-220Y	C RESISTOR	22 5% 1/4W	
	Q 571	2SC2785/FE/-T	TRANSISTOR				R 545	QRE141J-333Y	C RESISTOR	33K 5% 1/4W	
	Q 572	2SC2785/FE/-T	TRANSISTOR				R 546	QRE141J-103Y	C RESISTOR	10K 5% 1/4W	
	Q 573	2SC2785/FE/-T	TRANSISTOR				R 551	QRE141J-472Y	C RESISTOR	4.7K 5% 1/4W	
	R 401	QRE141J-102Y	C RESISTOR	1.0K 5% 1/4W			R 552	QRE141J-472Y	C RESISTOR	4.7K 5% 1/4W	
	R 402	QRE141J-102Y	C RESISTOR	1.0K 5% 1/4W			R 553	QRE141J-113Y	C RESISTOR	11K 5% 1/4W	
	R 403	QRE141J-472Y	C RESISTOR	4.7K 5% 1/4W			R 554	QRE141J-113Y	C RESISTOR	11K 5% 1/4W	
	R 404	QRE141J-472Y	C RESISTOR	4.7K 5% 1/4W			R 570	QRE141J-562Y	C RESISTOR	5.6K 5% 1/4W	
	R 405	QRE141J-223Y	C RESISTOR	22K 5% 1/4W			R 571	QRE141J-271Y	C RESISTOR	270 5% 1/4W	
	R 406	QRE141J-223Y	C RESISTOR	22K 5% 1/4W			R 572	QRE141J-473Y	C RESISTOR	47K 5% 1/4W	
	R 407	QRE141J-272Y	C RESISTOR	2.7K 5% 1/4W			R 573	QRE141J-113Y	C RESISTOR	11K 5% 1/4W	
	R 411	QRE141J-363Y	C RESISTOR	36K 5% 1/4W			R 575	QRE141J-473Y	C RESISTOR	47K 5% 1/4W	
	R 412	QRE141J-363Y	C RESISTOR	36K 5% 1/4W			R 576	QRE141J-104Y	C RESISTOR	100K 5% 1/4W	
	R 413	QRE141J-123Y	C RESISTOR	12K 5% 1/4W			R 577	QRE141J-104Y	C RESISTOR	100K 5% 1/4W	
	R 414	QRE141J-123Y	C RESISTOR	12K 5% 1/4W			R 579	QRE141J-154Y	C RESISTOR	150K 5% 1/4W	
	R 426	QRE141J-560Y	C RESISTOR	56 5% 1/4W			R 580	QRE141J-682Y	C RESISTOR	6.8K 5% 1/4W	
	R 435	QRE141J-683Y	C RESISTOR	68K 5% 1/4W			R 581	QRE141J-224Y	C RESISTOR	220K 5% 1/4W	
	R 440	QRE141J-912Y	C RESISTOR	9.1K 5% 1/4W			R 582	QRE141J-101Y	C RESISTOR	100 5% 1/4W	
	R 442	QRE141J-682Y	C RESISTOR	6.8K 5% 1/4W			R 583	QRE141J-101Y	C RESISTOR	100 5% 1/4W	
	R 443	QRE141J-243Y	C RESISTOR	24K 5% 1/4W			R 585	QRE141J-104Y	C RESISTOR	100K 5% 1/4W	
	R 444	QRE141J-682Y	C RESISTOR	6.8K 5% 1/4W			R 587	QRE141J-101Y	C RESISTOR	100 5% 1/4W	
	R 445	QRE141J-243Y	C RESISTOR	24K 5% 1/4W			R 588	QRE141J-102Y	C RESISTOR	1.0K 5% 1/4W	
	R 446	QRE141J-392Y	C RESISTOR	3.9K 5% 1/4W			R 589	QRE141J-102Y	C RESISTOR	1.0K 5% 1/4W	
	R 447	QRE141J-104Y	C RESISTOR	100K 5% 1/4W			SP434	GV40205-001A	IC HOLDER		
	R 450	QRE141J-124Y	C RESISTOR	120K 5% 1/4W							
	R 451	QRE141J-183Y	C RESISTOR	18K 5% 1/4W							
	R 452	QRE141J-682Y	C RESISTOR	6.8K 5% 1/4W							
	R 453	QRE141J-563Y	C RESISTOR	56K 5% 1/4W							
	R 454	QRE141J-154Y	C RESISTOR	150K 5% 1/4W							
	R 455	QRE141J-563Y	C RESISTOR	56K 5% 1/4W							
	R 456	QRE141J-154Y	C RESISTOR	150K 5% 1/4W							
	R 458	QRE141J-102Y	C RESISTOR	1.0K 5% 1/4W							
	R 459	QRE141J-102Y	C RESISTOR	1.0K 5% 1/4W							
	R 460	QRE141J-102Y	C RESISTOR	1.0K 5% 1/4W							
	R 477	QRE141J-123Y	C RESISTOR	12K 5% 1/4W							
	R 478	QRE141J-122Y	C RESISTOR	1.2K 5% 1/4W							
	R 480	QRE141J-103Y	C RESISTOR	10K 5% 1/4W							
	R 481	QRE141J-103Y	C RESISTOR	10K 5% 1/4W							
	R 482	QRE141J-103Y	C RESISTOR	10K 5% 1/4W							
	R 493	QRE141J-103Y	C RESISTOR	10K 5% 1/4W							
	R 494	QRE141J-103Y	C RESISTOR	10K 5% 1/4W							
	R 495	QRE141J-103Y	C RESISTOR	10K 5% 1/4W							
	R 496	QRE141J-102Y	C RESISTOR	1.0K 5% 1/4W							
	R 497	QRE141J-103Y	C RESISTOR	10K 5% 1/4W							
	R 501	QRE141J-104Y	C RESISTOR	100K 5% 1/4W							
	R 502	QRE141J-104Y	C RESISTOR	100K 5% 1/4W							
	R 503	QRE141J-303Y	C RESISTOR	30K 5% 1/4W							
	R 504	QRE141J-104Y	C RESISTOR	100K 5% 1/4W							
	R 505	QRE141J-223Y	C RESISTOR	22K 5% 1/4W							
	R 506	QRE141J-223Y	C RESISTOR	22K 5% 1/4W							
	R 507	QRE141J-303Y	C RESISTOR	30K 5% 1/4W							
	R 508	QRE141J-274Y	C RESISTOR	270K 5% 1/4W							
	R 509	QRE141J-101Y	C RESISTOR	100 5% 1/4W							
	R 510	QRE141J-823Y	C RESISTOR	82K 5% 1/4W							
	R 511	QRE141J-104Y	C RESISTOR	100K 5% 1/4W							
	R 512	QRE141J-563Y	C RESISTOR	56K 5% 1/4W							
	R 513	QRE141J-103Y	C RESISTOR	10K 5% 1/4W							
	R 514	QRE141J-822Y	C RESISTOR	8.2K 5% 1/4W							
	R 515	QRE141J-114Y	C RESISTOR	110K 5% 1/4W							
△	R 533	QRZ9006-4R7X	F RESISTOR	4.7 1/4W							
	R 534	QRE141J-473Y	C RESISTOR	47K 5% 1/4W							

■ Electrical parts list (Front board)

Block No. 03

△	Item	Parts number	Parts name	Remarks	Area	△	Item	Parts number	Parts name	Remarks	Area
	BZ801	QAN0045-001	BUZZER				C 902	QCFB1HZ-105Y	C CAPACITOR	1.0MF +80:-20%	
	C 201	QFKC2EK-104	METAL CAPACITOR	.10MF 10% 250V			C 958	QDYB1CM-103Y	C CAPACITOR		
	C 202	QFKC2EK-104	METAL CAPACITOR	.10MF 10% 250V			C 959	QDYB1CM-103Y	C CAPACITOR		
	C 203	QFKC2EK-104	METAL CAPACITOR	.10MF 10% 250V			C 960	QDYB1CM-103Y	C CAPACITOR		
	C 204	QEZO581-478	E CAPACITOR	4700MF			C 961	QDYB1CM-103Y	C CAPACITOR		
	C 205	QEZO581-478	E CAPACITOR	4700MF			C 962	QDYB1CM-103Y	C CAPACITOR		
	C 211	QFLM1HJ-823Z	M CAPACITOR	.082MF 5% 50V			C 963	QDYB1CM-103Y	C CAPACITOR		
	C 212	QFLM1HJ-823Z	M CAPACITOR	.082MF 5% 50V			CN 43	QGF1210G1-09	CONNECTOR		
	C 213	QFLM1HJ-823Z	M CAPACITOR	.082MF 5% 50V			CN205	QGB2510J1-15	CONNECTOR		
	C 214	QETM1HM-228	E CAPACITOR	2200MF 20% 50V			CN206	QGA2501F1-02	CONNECTOR		
	C 215	QETM1HM-228	E CAPACITOR	2200MF 20% 50V			CN207	QGB2510K2-07	CONNECTOR		
	C 217	QETN1JM-107Z	E CAPACITOR	100MF 20% 63V			CN701	QGD2503F1-04	SOCKET		
	C 218	QETN1HM-226Z	E CAPACITOR	22MF 20% 50V			CN860	QGF1210G1-21	CONNECTOR		
	C 219	QDYB1CM-103Y	C CAPACITOR				CN880	QGF1210G1-13	CONNECTOR		
	C 220	QETN1HM-226Z	E CAPACITOR	22MF 20% 50V			CN890	QGF1205F1-13	CONNECTOR		
	C 221	QETN1HM-475Z	E CAPACITOR	4.7MF 20% 50V		△	CP 1	ICP-N15-T	ICP		
	C 222	QETN1HM-475Z	E CAPACITOR	4.7MF 20% 50V			C1003	QDXB1CM-222Y	C CAPACITOR		
	C 236	QETM1EM-338	E CAPACITOR	3300MF 20% 25V			C1004	QDGB1HK-102Y	C CAPACITOR		
	C 240	QETN1HM-106Z	E CAPACITOR	10MF 20% 50V			C1005	QDGB1HK-102Y	C CAPACITOR		
	C 260	QETN1EM-476Z	E CAPACITOR	47MF 20% 25V			C1006	QDGB1HK-102Y	C CAPACITOR		
	C 601	FQCF31HZ-223Z	D CAPACITOR			△	D 201	1N5402M-20	DIODE		
	C 602	FQCF31HZ-223Z	D CAPACITOR			△	D 202	1N5402M-20	DIODE		
	C 603	QCBB1HK-221Y	C CAPACITOR	220PF 10% 50V		△	D 203	1N5402M-20	DIODE		
	C 604	QCBB1HK-221Y	C CAPACITOR	220PF 10% 50V		△	D 204	1N5402M-20	DIODE		
	C 605	QCBB1HK-221Y	C CAPACITOR	220PF 10% 50V		△	D 211	1N5402M-20	DIODE		
	C 606	QCBB1HK-221Y	C CAPACITOR	220PF 10% 50V		△	D 212	1N5402M-20	DIODE		
	C 607	QETN1JM-476Z	E CAPACITOR	47MF 20% 63V		△	D 213	1N5402M-20	DIODE		
	C 608	QETN1JM-476Z	E CAPACITOR	47MF 20% 63V		△	D 214	1N5402M-20	DIODE		
	C 609	QCSB1HJ-100Y	C CAPACITOR	10PF 5% 50V			D 219	DZ33BSC-T2	ZENER DIODE		
	C 610	QCSB1HJ-100Y	C CAPACITOR	10PF 5% 50V			D 220	DZ9.1BSB-T2	ZENER DIODE		
	C 611	QETN1HM-476Z	E CAPACITOR	47MF 20% 50V			D 221	1SS119-041-T2	SI DIODE		
	C 612	QETN1HM-476Z	E CAPACITOR	47MF 20% 50V			D 240	DZ13BSB-T2	ZENER DIODE		
	C 613	QFLM1HJ-473Z	M CAPACITOR	.047MF 5% 50V			D 260	1SS119-041-T2	SI DIODE		
	C 614	QFLM1HJ-473Z	M CAPACITOR	.047MF 5% 50V			D 261	1SS119-041-T2	SI DIODE		
	C 615	QFLM1HJ-473Z	M CAPACITOR	.047MF 5% 50V			D 262	1SS119-041-T2	SI DIODE		
	C 616	QFLM1HJ-473Z	M CAPACITOR	.047MF 5% 50V			D 263	1SS119-041-T2	SI DIODE		
	C 621	QTE1V06-106Z	E CAPACITOR				D 264	DZ5.1BSB-T2	ZENER DIODE		
	C 622	QTE1V06-106Z	E CAPACITOR				D 619	1SS119-041-T2	SI DIODE		
	C 623	QTE1V06-106Z	E CAPACITOR				D 620	1SS119-041-T2	SI DIODE		
	C 624	QTE1V06-106Z	E CAPACITOR				D 622	DZ9.1BSB-T2	ZENER DIODE		
	C 639	QETN1HM-105Z	E CAPACITOR	1.0MF 20% 50V			D 650	1SS119-041-T2	SI DIODE		
	C 801	FQCF31HP-103Z	C CAPACITOR				D 725	1SS119-041-T2	SI DIODE		
	C 803	QEKC0JM-227Z	E CAPACITOR	220MF 20% 6.3V			D 801	1SS119-041-T2	SI DIODE		
	C 804	QEKC0JM-227Z	E CAPACITOR	220MF 20% 6.3V			D 802	1SS119-041-T2	SI DIODE		
	C 805	QDGB1HK-102Y	C CAPACITOR				D 803	RB721Q-40-T2	SI DIODE		
	C 806	QEKC0JM-227Z	E CAPACITOR	220MF 20% 6.3V			D 804	1SS119-041-T2	SI DIODE		
	C 808	QCSB1HJ-270Y	C CAPACITOR	27PF 5% 50V			D 805	1SS119-041-T2	SI DIODE		
	C 809	QCSB1HJ-300Y	C CAPACITOR	30PF 5% 50V			D 806	1SS119-041-T2	SI DIODE		
	C 815	QEKC1HM-226Z	E CAPACITOR	22MF 20% 50V			D 807	RB721Q-40-T2	SI DIODE		
	C 817	QETN1HM-226Z	E CAPACITOR	22MF 20% 50V			D 810	1SS119-041-T2	SI DIODE		
	C 820	QCZ0202-155Z	ML C CAPACITOR	1.5MF			D 831	DZ5.1BSB-T2	ZENER DIODE		
	C 821	QDYB1CM-103Y	C CAPACITOR				D 832	DZ5.1BSB-T2	ZENER DIODE		
	C 823	QFVJ1HJ-334Z	MF CAPACITOR	.33MF 5% 50V			D 833	DZ4.3BSB-T2	ZENER DIODE		
	C 825	QDGB1HK-102Y	C CAPACITOR				D 901	L-192ZSRD-T	LED		
	C 831	QDYB1CM-103Y	C CAPACITOR				D 902	L-192ZSRD-T	LED		
	C 832	QDYB1CM-103Y	C CAPACITOR				D 903	L-192ZSRD-T	LED		
	C 835	QDGB1HK-102Y	C CAPACITOR				D 942	L-192ZSRD-T	LED		
	C 836	QEKC1EM-106Z	E CAPACITOR	10MF 20% 25V			D 943	L-192ZSRD-T	LED		
	C 837	QETN1AM-107Z	E CAPACITOR	100MF 20% 10V			D 944	L-192ZSRD-T	LED		
	C 838	QDGB1HK-102Y	C CAPACITOR				D 945	L-192ZSRD-T	LED		
	C 840	QEKC0JM-107Z	E CAPACITOR	100MF 20% 6.3V			D 946	L-192ZSRD-T	LED		
	C 889	QEKC1HM-475Z	E CAPACITOR	4.7MF 20% 50V			D 947	L-192ZSRD-T	LED		
	C 901	QCFB1HZ-105Y	C CAPACITOR	1.0MF +80:-20%			D 948	L-192ZSRD-T	LED		

■ Electrical parts list (Front board)

Block No. 03

△	Item	Parts number	Parts name	Remarks	Area	△	Item	Parts number	Parts name	Remarks	Area
	D 950	L-192ZSRD-T	LED				Q 890	2SD1991A/RS/-T	TRANSISTOR		
	D 951	L-192ZSRD-T	LED				Q 916	KTA1267/YG/-T	TRANSISTOR		
	D 962	L-192ZSRD-T	LED				Q 917	KRC102M-T	D.TRANSISTOR		
	D 972	LC503MUR1-30Q	LED				Q 961	KTA1267/YG/-T	TRANSISTOR		
	D 973	LC503MUR1-30Q	LED				Q 962	KRC102M-T	D.TRANSISTOR		
	D1003	DZ2.4BSB-T2	ZENER DIODE			△	R 202	QRJ146J-470X	UNF C RESISTOR	47 5% 1/4W	
	FL801	QLF0096-001	FL TUBE				R 203	QRE141J-752Y	C RESISTOR	7.5K 5% 1/4W	
	FW202	QUM157-07DGZ4	FLAT WIRE				R 204	QRE141J-223Y	C RESISTOR	22K 5% 1/4W	
	FW204	QJK015-050604	FLAT WIRE				R 205	QRE141J-104Y	C RESISTOR	100K 5% 1/4W	
	FW221	QUM156-13DGZ4	FLAT WIRE				R 215	QRE141J-473Y	C RESISTOR	47K 5% 1/4W	
	FW711	QUM154-33DGZ4	FLAT WIRE				R 216	QRE141J-473Y	C RESISTOR	47K 5% 1/4W	
	FW800	QUM023-05Z4Z4	FLAT WIRE				R 217	QRE141J-273Y	C RESISTOR	27K 5% 1/4W	
△	IC240	KIA7812API	IC			△	R 218	QRE141J-273Y	C RESISTOR	27K 5% 1/4W	
△	IC602	STK402-050	IC(HYBRID)			△	R 240	QRZ9005-100X	F RESISTOR	10 1/4W	
	IC810	UPD784975AGF303	IC				R 260	QRE141J-202Y	C RESISTOR	2.0K 5% 1/4W	
	IC811	BU2092	IC				R 261	QRE141J-202Y	C RESISTOR	2.0K 5% 1/4W	
	IC951	GP1UM271XK	IR DETECT UNIT				R 262	QRE141J-202Y	C RESISTOR	2.0K 5% 1/4W	
	J 81	QNB0151-002	SPK TERMINAL				R 263	QRE141J-202Y	C RESISTOR	2.0K 5% 1/4W	
	JS958	QSW0984-001	ROTARY ENCODER	SEARCH		△	R 601	QRJ146J-101X	UNF C RESISTOR	100 5% 1/4W	
	JS960	QSW0983-001	ROTARY ENCODER	S/MODE VOL		△	R 602	QRJ146J-101X	UNF C RESISTOR	100 5% 1/4W	
	JS962	QSW0862-001	ROTARY SWITCH	MAIN VOL			R 603	QRE141J-563Y	C RESISTOR	56K 5% 1/4W	
	J1001	QNS0204-001	3.5 JACK				R 604	QRE141J-563Y	C RESISTOR	56K 5% 1/4W	
	L 601	QQLZ035-R39	INDUCTOR			△	R 605	FQRJ143J-122X	UNF C RESISTOR		
	L 602	QQLZ035-R39	INDUCTOR			△	R 606	FQRJ143J-122X	UNF C RESISTOR		
	L 801	QQL244K-100Z	INDUCTOR				R 607	QRE141J-563Y	C RESISTOR	56K 5% 1/4W	
	L 802	QQL231K-220Y	INDUCTOR				R 608	QRE141J-563Y	C RESISTOR	56K 5% 1/4W	
	L 803	QQL29BJ-100Z	INDUCTOR			△	R 613	QRJ146J-100X	UNF C RESISTOR	10 5% 1/4W	
	L 805	QQL244K-100Z	INDUCTOR			△	R 614	QRJ146J-100X	UNF C RESISTOR	10 5% 1/4W	
	L 806	QQL244K-100Z	INDUCTOR			△	R 615	FQRJ143J-100X	UNF C RESISTOR		
	L 807	QQL231K-220Y	INDUCTOR			△	R 616	FQRJ143J-100X	UNF C RESISTOR		
	L 815	QQR0621-001Z	FERRITE BEADS				R 617	QRE141J-221Y	C RESISTOR	220 5% 1/4W	
	L 872	QQR0621-001Z	FERRITE BEADS				R 618	QRE141J-221Y	C RESISTOR	220 5% 1/4W	
	L1003	QQL231K-2R2Y	INDUCTOR				R 619	QRE141J-222Y	C RESISTOR	2.2K 5% 1/4W	
	Q 201	KTA1273/Y/-T	TRANSISTOR				R 620	QRE141J-222Y	C RESISTOR	2.2K 5% 1/4W	
	Q 260	KTC3203/OY/-T	TRANSISTOR				R 621	QRE141J-103Y	C RESISTOR	10K 5% 1/4W	
	Q 601	KTA1268/GL/-T	TRANSISTOR				R 623	QRE141J-103Y	C RESISTOR	10K 5% 1/4W	
	Q 602	KTA1268/GL/-T	TRANSISTOR			△	R 637	QRK126J-471X	C RESISTOR	470 5% 1/2W	
	Q 612	2SA1175/FE/-T	TRANSISTOR			△	R 639	QRL01DJ-821X	OMF RESISTOR	820 5% 1W	
	Q 613	KRC102M-T	D.TRANSISTOR			△	R 640	QRL01DJ-821X	OMF RESISTOR	820 5% 1W	
	Q 690	2SC2785/FE/-T	TRANSISTOR			△	R 653	QRT01DJ-R22X	MF RESISTOR	5% 1W	
	Q 733	2SC3576-JVC-T	TRANSISTOR			△	R 655	QRT01DJ-R22X	MF RESISTOR	5% 1W	
	Q 734	2SC3576-JVC-T	TRANSISTOR				R 666	QRE141J-333Y	C RESISTOR	33K 5% 1/4W	
	Q 735	2SC3576-JVC-T	TRANSISTOR				R 667	QRE141J-103Y	C RESISTOR	10K 5% 1/4W	
	Q 736	2SC3576-JVC-T	TRANSISTOR				R 668	QRE141J-103Y	C RESISTOR	10K 5% 1/4W	
	Q 737	KRA111M-T	D TRANSISTOR			△	R 674	QRJ146J-100X	UNF C RESISTOR	10 5% 1/4W	
	Q 810	2SD1991A/RS/-T	TRANSISTOR				R 675	QRE141J-102Y	C RESISTOR	1.0K 5% 1/4W	
	Q 811	2SD1991A/RS/-T	TRANSISTOR				R 676	QRE141J-102Y	C RESISTOR	1.0K 5% 1/4W	
	Q 812	2SD1991A/RS/-T	TRANSISTOR				R 690	QRE141J-103Y	C RESISTOR	10K 5% 1/4W	
	Q 813	2SD1991A/RS/-T	TRANSISTOR				R 725	QRE141J-823Y	C RESISTOR	82K 5% 1/4W	
	Q 814	2SD1991A/RS/-T	TRANSISTOR				R 726	QRE141J-104Y	C RESISTOR	100K 5% 1/4W	
	Q 815	2SD1991A/RS/-T	TRANSISTOR				R 733	QRE141J-472Y	C RESISTOR	4.7K 5% 1/4W	
	Q 816	2SD1991A/RS/-T	TRANSISTOR				R 734	QRE141J-472Y	C RESISTOR	4.7K 5% 1/4W	
	Q 817	2SD1991A/RS/-T	TRANSISTOR				R 735	QRE141J-472Y	C RESISTOR	4.7K 5% 1/4W	
	Q 818	2SD1991A/RS/-T	TRANSISTOR				R 736	QRE141J-472Y	C RESISTOR	4.7K 5% 1/4W	
	Q 819	2SD1991A/RS/-T	TRANSISTOR			△	R 737	QRK126J-471X	C RESISTOR	470 5% 1/2W	
	Q 820	2SD1991A/RS/-T	TRANSISTOR				R 801	QRE141J-331Y	C RESISTOR	330 5% 1/4W	
	Q 821	2SD1991A/RS/-T	TRANSISTOR				R 802	QRE141J-270Y	C RESISTOR	27 5% 1/4W	
	Q 822	2SD1991A/RS/-T	TRANSISTOR				R 805	QRE141J-103Y	C RESISTOR	10K 5% 1/4W	
	Q 823	2SD1991A/RS/-T	TRANSISTOR				R 806	QRE141J-103Y	C RESISTOR	10K 5% 1/4W	
	Q 833	KRA111M-T	D.TRANSISTOR				R 807	QRE141J-102Y	C RESISTOR	1.0K 5% 1/4W	
	Q 858	2SD1991A/RS/-T	TRANSISTOR				R 808	QRE141J-104Y	C RESISTOR	100K 5% 1/4W	
	Q 875	KRC102M-T	D.TRANSISTOR				R 810	QRE141J-103Y	C RESISTOR	10K 5% 1/4W	
	Q 879	2SD1991A/RS/-T	TRANSISTOR				R 811	QRE141J-103Y	C RESISTOR	10K 5% 1/4W	

■ Electrical parts list (Front board)

Block No. 03

△	Item	Parts number	Parts name	Remarks	Area	△	Item	Parts number	Parts name	Remarks	Area
	R 812	QRE141J-103Y	C RESISTOR	10K 5% 1/4W			R 880	QRE141J-104Y	C RESISTOR	100K 5% 1/4W	
	R 813	QRE141J-221Y	C RESISTOR	220 5% 1/4W			R 881	QRE141J-103Y	C RESISTOR	10K 5% 1/4W	
	R 814	QRE141J-562Y	C RESISTOR	5.6K 5% 1/4W			R 882	QRE141J-103Y	C RESISTOR	10K 5% 1/4W	
	R 815	QRE141J-103Y	C RESISTOR	10K 5% 1/4W			R 883	QRE141J-103Y	C RESISTOR	10K 5% 1/4W	
	R 816	QRE141J-104Y	C RESISTOR	100K 5% 1/4W			R 884	QRE141J-102Y	C RESISTOR	1.0K 5% 1/4W	
	R 817	QRE141J-103Y	C RESISTOR	10K 5% 1/4W			R 885	QRE141J-103Y	C RESISTOR	10K 5% 1/4W	
	R 818	QRE141J-103Y	C RESISTOR	10K 5% 1/4W			R 886	QRE141J-103Y	C RESISTOR	10K 5% 1/4W	
	R 819	QRE141J-102Y	C RESISTOR	1.0K 5% 1/4W			R 887	QRE141J-221Y	C RESISTOR	220 5% 1/4W	
	R 820	QRE141J-102Y	C RESISTOR	1.0K 5% 1/4W			R 888	QRE141J-221Y	C RESISTOR	220 5% 1/4W	
	R 821	QRE141J-104Y	C RESISTOR	100K 5% 1/4W			R 889	QRE141J-221Y	C RESISTOR	220 5% 1/4W	
	R 822	QRE141J-104Y	C RESISTOR	100K 5% 1/4W			R 890	QRE141J-133Y	C RESISTOR	13K 5% 1/4W	
	R 823	QRE141J-104Y	C RESISTOR	100K 5% 1/4W			R 891	QRE141J-104Y	C RESISTOR	100K 5% 1/4W	
	R 824	QRE141J-104Y	C RESISTOR	100K 5% 1/4W			R 892	QRE141J-103Y	C RESISTOR	10K 5% 1/4W	
	R 825	QRE141J-104Y	C RESISTOR	100K 5% 1/4W			R 893	QRE141J-102Y	C RESISTOR	1.0K 5% 1/4W	
	R 826	QRE141J-104Y	C RESISTOR	100K 5% 1/4W			R 894	QRE141J-102Y	C RESISTOR	1.0K 5% 1/4W	
	R 827	QRE141J-102Y	C RESISTOR	1.0K 5% 1/4W			R 895	QRE141J-102Y	C RESISTOR	1.0K 5% 1/4W	
	R 828	QRE141J-103Y	C RESISTOR	10K 5% 1/4W			R 896	QRE141J-103Y	C RESISTOR	10K 5% 1/4W	
	R 829	QRE141J-103Y	C RESISTOR	10K 5% 1/4W			R 897	QRE141J-103Y	C RESISTOR	10K 5% 1/4W	
	R 830	QRE141J-104Y	C RESISTOR	100K 5% 1/4W			R 899	QRE141J-103Y	C RESISTOR	10K 5% 1/4W	
	R 831	QRE141J-104Y	C RESISTOR	100K 5% 1/4W			R 900	QRE141J-102Y	C RESISTOR	1.0K 5% 1/4W	
	R 832	QRE141J-104Y	C RESISTOR	100K 5% 1/4W			R 901	QRE141J-102Y	C RESISTOR	1.0K 5% 1/4W	
	R 833	QRE141J-104Y	C RESISTOR	100K 5% 1/4W			R 902	QRE141J-122Y	C RESISTOR	1.2K 5% 1/4W	
	R 834	QRE141J-104Y	C RESISTOR	100K 5% 1/4W			R 903	QRE141J-152Y	C RESISTOR	1.5K 5% 1/4W	
	R 835	QRE141J-104Y	C RESISTOR	100K 5% 1/4W			R 904	QRE141J-222Y	C RESISTOR	2.2K 5% 1/4W	
	R 836	QRE141J-104Y	C RESISTOR	100K 5% 1/4W			R 905	QRE141J-272Y	C RESISTOR	2.7K 5% 1/4W	
	R 837	QRE141J-104Y	C RESISTOR	100K 5% 1/4W			R 906	QRE141J-392Y	C RESISTOR	3.9K 5% 1/4W	
	R 838	QRE141J-102Y	C RESISTOR	1.0K 5% 1/4W			R 907	QRE141J-163Y	C RESISTOR	16K 5% 1/4W	
	R 839	QRE141J-102Y	C RESISTOR	1.0K 5% 1/4W			R 908	QRE141J-103Y	C RESISTOR	10K 5% 1/4W	
	R 840	QRE141J-103Y	C RESISTOR	10K 5% 1/4W			R 909	QRE141J-334Y	C RESISTOR	330K 5% 1/4W	
	R 841	QRE141J-103Y	C RESISTOR	10K 5% 1/4W			R 911	QRE141J-201Y	C RESISTOR	200 5% 1/4W	
	R 842	QRE141J-104Y	C RESISTOR	100K 5% 1/4W			R 912	QRE141J-201Y	C RESISTOR	200 5% 1/4W	
	R 844	QRE141J-104Y	C RESISTOR	100K 5% 1/4W			R 913	QRE141J-201Y	C RESISTOR	200 5% 1/4W	
	R 845	QRE141J-102Y	C RESISTOR	1.0K 5% 1/4W			R 916	QRE141J-223Y	C RESISTOR	22K 5% 1/4W	
	R 846	QRE141J-102Y	C RESISTOR	1.0K 5% 1/4W			R 917	QRE141J-103Y	C RESISTOR	10K 5% 1/4W	
	R 847	QRE141J-102Y	C RESISTOR	1.0K 5% 1/4W			R 918	QRE141J-133Y	C RESISTOR	13K 5% 1/4W	
	R 848	QRE141J-331Y	C RESISTOR	330 5% 1/4W			R 919	QRE141J-104Y	C RESISTOR	100K 5% 1/4W	
	R 849	QRE141J-102Y	C RESISTOR	1.0K 5% 1/4W			R 920	QRE141J-102Y	C RESISTOR	1.0K 5% 1/4W	
	R 850	QRE141J-102Y	C RESISTOR	1.0K 5% 1/4W			R 921	QRE141J-102Y	C RESISTOR	1.0K 5% 1/4W	
	R 851	QRE141J-153Y	C RESISTOR	15K 5% 1/4W			R 922	QRE141J-122Y	C RESISTOR	1.2K 5% 1/4W	
	R 852	QRE141J-104Y	C RESISTOR	100K 5% 1/4W			R 923	QRE141J-152Y	C RESISTOR	1.5K 5% 1/4W	
	R 853	QRE141J-104Y	C RESISTOR	100K 5% 1/4W			R 924	QRE141J-222Y	C RESISTOR	2.2K 5% 1/4W	
	R 854	QRE141J-102Y	C RESISTOR	1.0K 5% 1/4W			R 925	QRE141J-272Y	C RESISTOR	2.7K 5% 1/4W	
	R 855	QRE141J-102Y	C RESISTOR	1.0K 5% 1/4W			R 926	QRE141J-392Y	C RESISTOR	3.9K 5% 1/4W	
	R 856	QRE141J-102Y	C RESISTOR	1.0K 5% 1/4W			R 927	QRE141J-562Y	C RESISTOR	5.6K 5% 1/4W	
	R 857	QRE141J-102Y	C RESISTOR	1.0K 5% 1/4W			R 928	QRE141J-103Y	C RESISTOR	10K 5% 1/4W	
	R 858	QRE141J-102Y	C RESISTOR	1.0K 5% 1/4W			R 929	QRE141J-334Y	C RESISTOR	330K 5% 1/4W	
	R 859	QRE141J-102Y	C RESISTOR	1.0K 5% 1/4W			R 930	QRE141J-104Y	C RESISTOR	100K 5% 1/4W	
	R 860	QRE141J-102Y	C RESISTOR	1.0K 5% 1/4W			R 931	QRE141J-104Y	C RESISTOR	100K 5% 1/4W	
	R 861	QRE141J-102Y	C RESISTOR	1.0K 5% 1/4W			R 932	QRE141J-104Y	C RESISTOR	100K 5% 1/4W	
	R 862	QRE141J-102Y	C RESISTOR	1.0K 5% 1/4W			R 933	QRE141J-104Y	C RESISTOR	100K 5% 1/4W	
	R 863	QRE141J-102Y	C RESISTOR	1.0K 5% 1/4W			R 934	QRE141J-104Y	C RESISTOR	100K 5% 1/4W	
	R 865	QRE141J-102Y	C RESISTOR	1.0K 5% 1/4W			R 935	QRE141J-104Y	C RESISTOR	100K 5% 1/4W	
	R 866	QRE141J-102Y	C RESISTOR	1.0K 5% 1/4W			R 936	QRE141J-104Y	C RESISTOR	100K 5% 1/4W	
	R 867	QRE141J-102Y	C RESISTOR	1.0K 5% 1/4W			R 937	QRE141J-104Y	C RESISTOR	100K 5% 1/4W	
	R 868	QRE141J-133Y	C RESISTOR	13K 5% 1/4W			R 938	QRE141J-104Y	C RESISTOR	100K 5% 1/4W	
	R 869	QRE141J-102Y	C RESISTOR	1.0K 5% 1/4W			R 939	QRE141J-104Y	C RESISTOR	100K 5% 1/4W	
	R 871	QRE141J-102Y	C RESISTOR	1.0K 5% 1/4W			R 940	QRE141J-104Y	C RESISTOR	100K 5% 1/4W	
	R 872	QRE141J-102Y	C RESISTOR	1.0K 5% 1/4W			R 941	QRE141J-102Y	C RESISTOR	1.0K 5% 1/4W	
	R 873	QRE141J-102Y	C RESISTOR	1.0K 5% 1/4W			R 942	QRE141J-102Y	C RESISTOR	1.0K 5% 1/4W	
	R 876	QRE141J-103Y	C RESISTOR	10K 5% 1/4W			R 943	QRE141J-122Y	C RESISTOR	1.2K 5% 1/4W	
	R 877	QRE141J-133Y	C RESISTOR	13K 5% 1/4W			R 944	QRE141J-152Y	C RESISTOR	1.5K 5% 1/4W	
	R 878	QRE141J-104Y	C RESISTOR	100K 5% 1/4W			R 945	QRE141J-222Y	C RESISTOR	2.2K 5% 1/4W	
	R 879	QRE141J-104Y	C RESISTOR	100K 5% 1/4W			R 946	QRE141J-272Y	C RESISTOR	2.7K 5% 1/4W	

■ Electrical parts list (Front board)

Block No. 03

△	Item	Parts number	Parts name	Remarks	Area
	R 947	QRE141J-392Y	C RESISTOR	3.9K 5% 1/4W	
	R 948	QRE141J-562Y	C RESISTOR	5.6K 5% 1/4W	
	R 949	QRE141J-103Y	C RESISTOR	10K 5% 1/4W	
	R 950	QRE141J-334Y	C RESISTOR	330K 5% 1/4W	
	R 952	QRE141J-201Y	C RESISTOR	200 5% 1/4W	
	R 953	QRE141J-201Y	C RESISTOR	200 5% 1/4W	
	R 954	QRE141J-201Y	C RESISTOR	200 5% 1/4W	
	R 955	QRE141J-201Y	C RESISTOR	200 5% 1/4W	
	R 956	QRE141J-201Y	C RESISTOR	200 5% 1/4W	
	R 957	QRE141J-201Y	C RESISTOR	200 5% 1/4W	
	R 958	QRE141J-201Y	C RESISTOR	200 5% 1/4W	
	R 959	QRE141J-201Y	C RESISTOR	200 5% 1/4W	
	R 960	QRE141J-201Y	C RESISTOR	200 5% 1/4W	
	R 961	QRE141J-101Y	C RESISTOR	100 5% 1/4W	
	R 962	QRE141J-472Y	C RESISTOR	4.7K 5% 1/4W	
	R 963	QRE141J-101Y	C RESISTOR	100 5% 1/4W	
	R 969	QRE141J-472Y	C RESISTOR	4.7K 5% 1/4W	
	R 970	QRE141J-103Y	C RESISTOR	10K 5% 1/4W	
	R 971	QRE141J-103Y	C RESISTOR	10K 5% 1/4W	
	R 972	QRE141J-102Y	C RESISTOR	1.0K 5% 1/4W	
	R 973	QRE141J-102Y	C RESISTOR	1.0K 5% 1/4W	
	R 975	QRE141J-102Y	C RESISTOR	1.0K 5% 1/4W	
	R 976	QRE141J-102Y	C RESISTOR	1.0K 5% 1/4W	
	R 978	QRE141J-102Y	C RESISTOR	1.0K 5% 1/4W	
	R 980	QRE141J-104Y	C RESISTOR	100K 5% 1/4W	
	R 981	QRE141J-104Y	C RESISTOR	100K 5% 1/4W	
	R 982	QRE141J-133Y	C RESISTOR	13K 5% 1/4W	
	R 983	QRE141J-104Y	C RESISTOR	100K 5% 1/4W	
	R 984	QRE141J-104Y	C RESISTOR	100K 5% 1/4W	
	R 985	QRE141J-104Y	C RESISTOR	100K 5% 1/4W	
	R 986	QRE141J-133Y	C RESISTOR	13K 5% 1/4W	
	R 987	QRE141J-104Y	C RESISTOR	100K 5% 1/4W	
	R 988	QRE141J-133Y	C RESISTOR	13K 5% 1/4W	
	R 989	QRE141J-133Y	C RESISTOR	13K 5% 1/4W	
	R 990	QRE141J-133Y	C RESISTOR	13K 5% 1/4W	
	R 991	QRE141J-133Y	C RESISTOR	13K 5% 1/4W	
	R 992	QRE141J-133Y	C RESISTOR	13K 5% 1/4W	
	R 993	QRE141J-104Y	C RESISTOR	100K 5% 1/4W	
	R 994	QRE141J-104Y	C RESISTOR	100K 5% 1/4W	
	R 998	QRE141J-103Y	C RESISTOR	10K 5% 1/4W	
	RY 1	QSK0109-001	RELAY		
	RY 2	QSK0109-001	RELAY		
	S 900	QSW0674-001Z	TACT SWITCH		
	S 901	QSW0674-001Z	TACT SWITCH		
	S 902	QSW0674-001Z	TACT SWITCH		
	S 903	QSW0674-001Z	TACT SWITCH		
	S 904	QSW0674-001Z	TACT SWITCH		
	S 905	QSW0674-001Z	TACT SWITCH		
	S 906	QSW0674-001Z	TACT SWITCH		
	S 920	QSW0674-001Z	TACT SWITCH		
	S 921	QSW0674-001Z	TACT SWITCH		
	S 922	QSW0674-001Z	TACT SWITCH		
	S 923	QSW0674-001Z	TACT SWITCH		
	S 924	QSW0674-001Z	TACT SWITCH		
	S 925	QSW0674-001Z	TACT SWITCH		
	S 926	QSW0674-001Z	TACT SWITCH		
	S 927	QSW0674-001Z	TACT SWITCH		
	S 928	QSW0674-001Z	TACT SWITCH		
	S 940	QSW0674-001Z	TACT SWITCH		
	S 941	QSW0674-001Z	TACT SWITCH		
	S 942	QSW0674-001Z	TACT SWITCH		
	S 943	QSW0674-001Z	TACT SWITCH		
	S 944	QSW0674-001Z	TACT SWITCH		

△	Item	Parts number	Parts name	Remarks	Area
	S 945	QSW0674-001Z	TACT SWITCH		
	S 946	QSW0674-001Z	TACT SWITCH		
	S 947	QSW0674-001Z	TACT SWITCH		
	S 948	QSW0674-001Z	TACT SWITCH		
	S 949	QSW0674-001Z	TACT SWITCH		
	SP801	VYH7653-001	IC HOLDER		
	SP810	GV40121-004A	SPACER		
	SP811	E3400-431	SPACER		
	SP812	GV40121-004A	SPACER		
	X 801	QAX0724-001Z	CRYSTAL		

■ Electrical parts list (Tuner board)

Block No. 04

△	Item	Parts number	Parts name	Remarks	Area
	C 1	NCB21HK-223X	C CAPACITOR		
	C 2	NCB21HK-103X	C CAPACITOR		
	C 3	EETC1CM-106ZJC	E CAPACITOR		
	C 4	NCB21HK-103X	C CAPACITOR		
	C 6	NCB21HK-102X	C CAPACITOR		
	C 7	NCB21HK-102X	C CAPACITOR		
	C 8	NCB21HK-102X	C CAPACITOR		
	C 10	NRSA02J-0R0X	MG RESISTOR		
	C 11	NCB21HK-104X	C CAPACITOR		
	C 12	NCB21HK-473X	C CAPACITOR		
	C 13	NCS21HJ-120X	C CAPACITOR		
	C 14	QEKC1AM-107Z	E CAPACITOR	100MF 20% 10V	
	C 15	NCS21HJ-120X	C CAPACITOR		
	C 16	NCS21HJ-120X	C CAPACITOR		
	C 17	NCB21HK-392X	C CAPACITOR		
	C 18	QENC1HM-474Z	NP E CAPACITOR	.47MF 20% 50V	
	C 19	NCB21HK-473X	C CAPACITOR		
	C 20	NCB21HK-102X	C CAPACITOR		
	C 21	NCB21HK-223X	C CAPACITOR		
	C 22	NCS21HJ-151X	C CAPACITOR		
	C 23	NCS21HJ-151X	C CAPACITOR		
	C 24	NCS21HJ-151X	C CAPACITOR		
	C 25	QEKC1AM-107Z	E CAPACITOR	100MF 20% 10V	
	C 26	NCB21HK-102X	C CAPACITOR		
	C 27	NCB21HK-102X	C CAPACITOR		
	C 30	EEKC1CM-107ZJC	E CAPACITOR		
	C 31	EEKC1CM-226ZJC	E CAPACITOR		
	C 32	NCB21HK-473X	C CAPACITOR		
	C 33	NCB21HK-473X	C CAPACITOR		
	C 34	NCB21HK-223X	C CAPACITOR		
	C 35	NCB21HK-473X	C CAPACITOR		
	C 36	EEKC1HM-105ZJC	E CAPACITOR		
	C 37	EEKC1HM-105ZJC	E CAPACITOR		
	C 38	EETC1HM-224ZJC	E CAPACITOR		
	C 39	EETC1HM-105ZJC	E CAPACITOR		
	C 40	QETN1CM-106Z	E CAPACITOR	10MF 20% 16V	
	C 41	QETN1CM-106Z	E CAPACITOR	10MF 20% 16V	
	C 42	NCB21HK-222X	C CAPACITOR		
	C 43	NCB21HK-222X	C CAPACITOR		
	C 44	QETN1CM-106Z	E CAPACITOR	10MF 20% 16V	
	C 45	QETN1CM-106Z	E CAPACITOR	10MF 20% 16V	
	C 46	NCB21HK-273X	C CAPACITOR		
	C 47	EETC1HM-105ZJC	E CAPACITOR		
	C 48	NCB21HK-222X	C CAPACITOR		
	C 49	NCS21HJ-471X	C CAPACITOR		
	C 50	EEKC1CM-226ZJC	E CAPACITOR		
	C 51	EEKC1HM-105ZJC	E CAPACITOR		
	C 52	QFVJ1HJ-274Z	MF CAPACITOR	.27MF 5% 50V	
	C 53	EETC1CM-226ZJC	E CAPACITOR		
	C 54	NCB21HK-473X	C CAPACITOR		
	C 57	NCB21HK-102X	C CAPACITOR		
	C 58	NCB21HK-473X	C CAPACITOR		
	C 59	NCB21HK-102X	C CAPACITOR		
	CF 1	QAX0677-001Z	C FILTER		
	CF 2	QAX0677-001Z	C FILTER		
	CF 3	QAX0610-001Z	C DISCRIMINATOR		
	CN 1	QGF1205F1-09	CONNECTOR		
	D 1	1SS133-T2	SI DIODE		
	D 2	1SS133-T2	SI DIODE		
	D 3	1SS133-T2	SI DIODE		
	D 4	1SS133-T2	SI DIODE		
	D 11	1SS133-T2	SI DIODE		
	IC 1	LA1838	IC		

△	Item	Parts number	Parts name	Remarks	Area
	IC 2	LC72136N	IC		
	J 1	QNB0014-001	ANT TERMINAL		
	L 1	QQR0796-002	COIL BLOCK		
	Q 1	2SC2814/4-5/-X	TRANSISTOR		
	Q 5	KRA107S-X	TRANSISTOR		
	R 1	QRE141J-560Y	C RESISTOR	56 5% 1/4W	
	R 2	NRSA02J-331X	MG RESISTOR		
	R 3	NRSA02J-224X	MG RESISTOR		
	R 4	NRSA02J-331X	MG RESISTOR		
	R 5	NRSA02J-560X	MG RESISTOR		
	R 6	NRSA02J-240X	MG RESISTOR		
	R 10	NRSA02J-222X	MG RESISTOR		
	R 13	NRSA02J-103X	MG RESISTOR		
	R 14	NRSA02J-104X	MG RESISTOR		
	R 15	NRSA02J-332X	MG RESISTOR		
	R 16	NRSA02J-472X	MG RESISTOR		
△	R 17	QRZ9005-680X	F RESISTOR	68 1/4W	
	R 18	NRSA02J-102X	MG RESISTOR		
	R 19	NRSA02J-102X	MG RESISTOR		
	R 20	NRSA02J-102X	MG RESISTOR		
	R 21	NRSA02J-562X	MG RESISTOR		
	R 22	NRSA02J-472X	MG RESISTOR		
	R 23	NRSA02J-182X	MG RESISTOR		
	R 24	NRSA02J-103X	MG RESISTOR		
	R 25	NRSA02J-331X	MG RESISTOR		
	R 26	NRSA02J-222X	MG RESISTOR		
	R 27	NRSA02J-103X	MG RESISTOR		
	R 28	NRSA02J-103X	MG RESISTOR		
	R 29	NRSA02J-103X	MG RESISTOR		
	R 30	NRSA02J-122X	MG RESISTOR		
	R 31	NRSA02J-102X	MG RESISTOR		
	R 32	NRSA02J-102X	MG RESISTOR		
	R 33	NRSA02J-331X	MG RESISTOR		
	R 34	NRSA02J-470X	MG RESISTOR		
	R 35	NRSA02J-562X	MG RESISTOR		
	R 36	NRSA02J-332X	MG RESISTOR		
	R 37	NRSA02J-103X	MG RESISTOR		
	R 38	NRSA02J-563X	MG RESISTOR		
	R 39	NRSA02J-563X	MG RESISTOR		
	R 40	NRSA02J-243X	MG RESISTOR		
	R 41	NRSA02J-332X	MG RESISTOR		
	R 60	NRSA02J-0R0X	MG RESISTOR		
	T 1	QQR0793-001	IFT		
	TU 1	QAU0161-001	FRONT END		
	X 1	QAX0402-001	CRYSTAL		

■ Electrical parts list (CD servo board)

Block No. 05

▲	Item	Parts number	Parts name	Remarks	Area	▲	Item	Parts number	Parts name	Remarks	Area
	C 253	NCB31CK-104X	C CAPACITOR				C 854	NCB31EK-103X	C CAPACITOR		
	C 254	QERF1AM-476Z	E CAPACITOR	47MF 20% 10V			C 855	NCB31CK-104X	C CAPACITOR		
	C 291	QERF1AM-476Z	E CAPACITOR	47MF 20% 10V			C 859	NCF31AZ-105X	C CAPACITOR		
	C 601	NCB31HK-222X	C CAPACITOR				C 860	NCF31AZ-105X	C CAPACITOR		
	C 602	NCB31HK-222X	C CAPACITOR				CN601	QGF1016F3-16	CONNECTOR		
	C 603	NCB31EK-223X	C CAPACITOR				CN651	QGF1016F3-19	CONNECTOR		
	C 604	NCB31EK-223X	C CAPACITOR				CN801	QGA2001C1-06	6P PLUG ASSY		
	C 605	NCS31HJ-471X	C CAPACITOR				CN854	QGB2016K1-07	CONNECTOR		
	C 606	NCS31HJ-820X	C CAPACITOR				CN855	QGG2002M4-10	CONNECTOR		
	C 608	NCB31HK-122X	C CAPACITOR				D 851	DZ5.6BSB-T2	ZENER DIODE		
	C 610	NCB31CK-273X	C CAPACITOR				IC251	UPD780024A-B76	IC		
	C 612	QERF1HM-105Z	E CAPACITOR	1.0MF 20% 50V			IC601	AN22000A-W	IC		
	C 613	NCB31AK-224X	C CAPACITOR				IC602	BA15218F-XE	IC		
	C 614	NCB31CK-273X	C CAPACITOR				IC651	MN35510AL	IC		
	C 615	NCB31HK-472X	C CAPACITOR				IC652	BA15218F-XE	IC		
	C 616	NCB31EK-103X	C CAPACITOR				IC801	LA6541-X	IC		
	C 617	NCS31HJ-331X	C CAPACITOR				IC851	LB1641	IC		
	C 620	NCS31HJ-330X	C CAPACITOR				IC852	LB1641	IC		
	C 621	NCB30JK-105X	C CAPACITOR				Q 291	2SA952/LK/-T	TRANSISTOR		
	C 622	NCB31CK-473X	C CAPACITOR				Q 631	2SB709A/RS/-X	TRANSISTOR		
	C 623	NCF31AZ-105X	C CAPACITOR				R 253	NRSA63J-102X	MG RESISTOR		
	C 624	QERF0JM-107Z	E CAPACITOR	100MF 20% 6.3V			R 254	NRSA63J-102X	MG RESISTOR		
	C 625	NCB31CK-104X	C CAPACITOR				R 255	NRSA63J-102X	MG RESISTOR		
	C 631	QERF1CM-106Z	E CAPACITOR	10MF 20% 16V			R 256	NRSA63J-102X	MG RESISTOR		
	C 632	NCF31AZ-105X	C CAPACITOR				R 257	NRSA63J-102X	MG RESISTOR		
	C 633	NCB31EK-223X	C CAPACITOR				R 260	NRSA63J-222X	MG RESISTOR		
	C 641	NCB31CK-473X	C CAPACITOR				R 261	NRSA63J-223X	MG RESISTOR		
	C 642	NCB31HK-472X	C CAPACITOR				R 262	NRSA63J-223X	MG RESISTOR		
	C 651	NCS31HJ-120X	C CAPACITOR				R 263	NRSA63J-223X	MG RESISTOR		
	C 652	NCS31HJ-120X	C CAPACITOR				R 264	NRSA63J-223X	MG RESISTOR		
	C 653	NCB31CK-104X	C CAPACITOR				R 265	NRSA63J-223X	MG RESISTOR		
	C 655	NCB31CK-104X	C CAPACITOR				R 278	NRSA63J-103X	MG RESISTOR		
	C 656	NCB31CK-104X	C CAPACITOR				R 280	NRSA63J-102X	MG RESISTOR		
	C 657	QERF1AM-227Z	E CAPACITOR	220MF 20% 10V			R 281	NRSA63J-102X	MG RESISTOR		
	C 658	NCB31CK-104X	C CAPACITOR				R 284	NRSA63J-102X	MG RESISTOR		
	C 661	NCS31HJ-471X	C CAPACITOR				R 291	NRSA63J-122X	MG RESISTOR		
	C 663	NCB31EK-223X	C CAPACITOR				R 292	NRSA63J-103X	MG RESISTOR		
	C 664	NCB31EK-223X	C CAPACITOR				R 294	NRSA63J-102X	MG RESISTOR		
	C 665	NCB31AK-154X	C CAPACITOR				R 601	NRSA63J-474X	MG RESISTOR		
	C 668	NCB31CK-473X	C CAPACITOR				R 602	NRSA63J-274X	MG RESISTOR		
	C 669	QERF1AM-227Z	E CAPACITOR	220MF 20% 10V			R 603	NRSA63J-393X	MG RESISTOR		
	C 672	NCB31AK-334X	C CAPACITOR				R 604	NRSA63J-274X	MG RESISTOR		
	C 673	ECA1AAD101XI	AL E CAPACITOR				R 606	NRSA63J-623X	MG RESISTOR		
	C 677	NCB31CK-104X	C CAPACITOR				R 607	NRSA63J-393X	MG RESISTOR		
	C 679	QERF0JM-107Z	E CAPACITOR	100MF 20% 6.3V			R 608	NRSA63J-0R0X	MG RESISTOR		
	C 680	NCB31CK-104X	C CAPACITOR				R 609	NRSA63J-472X	MG RESISTOR		
	C 691	NCS31HJ-391X	C CAPACITOR				R 611	NRSA63J-822X	MG RESISTOR		
	C 692	NCS31HJ-391X	C CAPACITOR				R 613	NRSA63J-472X	MG RESISTOR		
	C 693	NCB31HK-682X	C CAPACITOR				R 614	NRSA63J-153X	MG RESISTOR		
	C 694	NCB31HK-682X	C CAPACITOR				R 618	NRSA63J-472X	MG RESISTOR		
	C 695	NCB31CK-473X	C CAPACITOR				R 619	NRSA63J-472X	MG RESISTOR		
	C 696	QERF1CM-106Z	E CAPACITOR	10MF 20% 16V			R 620	NRSA63J-472X	MG RESISTOR		
	C 699	QERF1AM-227Z	E CAPACITOR	220MF 20% 10V			R 621	NRSA63J-472X	MG RESISTOR		
	C 801	NCB31HK-682X	C CAPACITOR				R 622	NRSA63J-223X	MG RESISTOR		
	C 802	NCB31HK-472X	C CAPACITOR				R 623	NRSA63J-223X	MG RESISTOR		
	C 811	NCS31HJ-391X	C CAPACITOR				R 626	NRSA63J-103X	MG RESISTOR		
	C 812	NCS31HJ-391X	C CAPACITOR				R 627	NRSA63J-103X	MG RESISTOR		
	C 813	NCS31HJ-391X	C CAPACITOR				R 628	NRSA63J-155X	MG RESISTOR		
	C 814	NCS31HJ-391X	C CAPACITOR				R 631	NRSA63J-2R2X	MG RESISTOR		
	C 821	NCF31AZ-105X	C CAPACITOR				R 632	NRSA63J-100X	MG RESISTOR		
	C 822	QERF1AM-227Z	E CAPACITOR	220MF 20% 10V			R 634	NRSA63J-120X	MG RESISTOR		
	C 852	QERF1CM-106Z	E CAPACITOR	10MF 20% 16V			R 635	NRSA63J-121X	MG RESISTOR		
	C 853	NCB31EK-103X	C CAPACITOR				R 636	NRSA63J-910X	MG RESISTOR		

■ Electrical parts list (CD servo board)

Block No. 05

△	Item	Parts number	Parts name	Remarks	Area
	R 641	NRSA63J-823X	MG RESISTOR		
	R 642	NRSA63J-564X	MG RESISTOR		
	R 651	NRSA63J-102X	MG RESISTOR		
	R 653	NRSA63J-102X	MG RESISTOR		
	R 655	NRSA63J-102X	MG RESISTOR		
	R 656	NRSA63J-102X	MG RESISTOR		
	R 657	NRSA63J-102X	MG RESISTOR		
	R 658	NRSA63J-102X	MG RESISTOR		
	R 659	NRSA63J-102X	MG RESISTOR		
	R 662	NRSA63J-683X	MG RESISTOR		
	R 663	NRSA63J-124X	MG RESISTOR		
	R 664	NRSA63J-331X	MG RESISTOR		
	R 665	NRSA63J-271X	MG RESISTOR		
	R 666	NRSA63J-221X	MG RESISTOR		
	R 667	NRSA63J-4R7X	MG RESISTOR		
	R 668	NRSA63J-155X	MG RESISTOR		
	R 670	NRSA63J-101X	MG RESISTOR		
	R 672	NRSA63J-272X	MG RESISTOR		
	R 682	NRSA63J-102X	MG RESISTOR		
	R 691	NRSA63J-103X	MG RESISTOR		
	R 692	NRSA63J-103X	MG RESISTOR		
	R 695	NRSA63J-243X	MG RESISTOR		
	R 696	NRSA63J-243X	MG RESISTOR		
	R 701	NRSA63J-821X	MG RESISTOR		
	R 702	NRSA63J-821X	MG RESISTOR		
	R 703	NRSA63J-103X	MG RESISTOR		
	R 704	NRSA63J-103X	MG RESISTOR		
	R 705	NRSA63J-562X	MG RESISTOR		
	R 706	NRSA63J-202X	MG RESISTOR		
	R 707	NRSA63J-682X	MG RESISTOR		
	R 708	NRSA63J-101X	MG RESISTOR		
	R 709	NRSA63J-101X	MG RESISTOR		
	R 710	NRSA63J-221X	MG RESISTOR		
	R 801	NRSA63J-272X	MG RESISTOR		
	R 802	NRSA63J-472X	MG RESISTOR		
	R 803	NRSA63J-472X	MG RESISTOR		
	R 804	NRSA63J-823X	MG RESISTOR		
	R 805	NRSA63J-912X	MG RESISTOR		
	R 806	NRSA63J-473X	MG RESISTOR		
	R 807	NRSA63J-272X	MG RESISTOR		
	R 808	NRSA63J-433X	MG RESISTOR		
	R 809	NRSA63J-122X	MG RESISTOR		
	R 811	NRSA63J-103X	MG RESISTOR		
	R 831	NRSA63J-151X	MG RESISTOR		
	R 832	NRSA63J-103X	MG RESISTOR		
	R 842	NRSA63J-472X	MG RESISTOR		
	R 851	NRSA63J-102X	MG RESISTOR		
	R 852	NRSA63J-102X	MG RESISTOR		
	R 853	NRSA63J-102X	MG RESISTOR		
	R 854	NRSA63J-102X	MG RESISTOR		
	R 861	NRSA63J-102X	MG RESISTOR		
	R 862	NRSA63J-102X	MG RESISTOR		
	R 863	NRSA63J-102X	MG RESISTOR		
	R 864	NRSA63J-102X	MG RESISTOR		
	R 865	NRSA63J-102X	MG RESISTOR		
	R 866	NRSA63J-102X	MG RESISTOR		
	R 880	NRSA63J-102X	MG RESISTOR		
	R 881	NRSA63J-102X	MG RESISTOR		
	R 882	NRSA63J-102X	MG RESISTOR		
	R 883	NRSA63J-102X	MG RESISTOR		
	R 884	NRSA63J-102X	MG RESISTOR		
	R 885	NRSA63J-102X	MG RESISTOR		
	R 886	NRSA63J-102X	MG RESISTOR		

△	Item	Parts number	Parts name	Remarks	Area
	R 887	NRSA63J-102X	MG RESISTOR		
	W 601	QUB220-07HPDT	SIN TWIST WIRE		
	X 251	QAX0720-001Z	C RESONATOR		
	X 651	QAX0413-001Z	CRYSTAL		

■ Electrical parts list (CD switch board)

Block No. 06

△	Item	Parts number	Parts name	Remarks	Area
	CN804	QGB2016J1-07	CONNECTOR		
	CN805	QGB2012J1-10	CONNECTOR		
	SW 1	QSW0859-001	LEVER SWITCH		
	SW 2	QSW0859-001	LEVER SWITCH		
	SW 3	QSW0859-001	LEVER SWITCH		
	SW 4	QSW0859-001	LEVER SWITCH		
	SW 5	QSW0859-001	LEVER SWITCH		
	SW 6	QSW0859-001	LEVER SWITCH		

■ Electrical parts list (Head amplifier board) Block No. 07

△	Item	Parts number	Parts name	Remarks	Area
	C 101	NCS21HJ-821X	C CAPACITOR		
	C 102	NCS21HJ-221X	C CAPACITOR		
	C 103	QEKJ0JM-227Z	E CAPACITOR	220MF 20% 6.3V	
	C 104	NCB21HK-333X	C CAPACITOR		
	C 105	NCB21HK-222X	C CAPACITOR		
	C 106	QEKJ1CM-106Z	E CAPACITOR	10MF 20% 16V	
	C 107	NCS21HJ-561X	C CAPACITOR		
	C 108	QEKJ1EM-475Z	E CAPACITOR	4.7MF 20% 25V	
	C 109	QEKJ1EM-475Z	E CAPACITOR	4.7MF 20% 25V	
	C 110	NCB21HK-682X	C CAPACITOR		
	C 111	NCB21HK-152X	C CAPACITOR		
	C 113	NCB21HK-393X	C CAPACITOR		
	C 121	NCS21HJ-331X	C CAPACITOR		
	C 201	NCS21HJ-821X	C CAPACITOR		
	C 202	NCS21HJ-221X	C CAPACITOR		
	C 203	QEKJ0JM-227Z	E CAPACITOR	220MF 20% 6.3V	
	C 204	NCB21HK-333X	C CAPACITOR		
	C 205	NCB21HK-222X	C CAPACITOR		
	C 206	QEKJ1CM-106Z	E CAPACITOR	10MF 20% 16V	
	C 207	NCS21HJ-561X	C CAPACITOR		
	C 208	QEKJ1EM-475Z	E CAPACITOR	4.7MF 20% 25V	
	C 209	QEKJ1EM-475Z	E CAPACITOR	4.7MF 20% 25V	
	C 210	NCB21HK-682X	C CAPACITOR		
	C 211	NCB21HK-152X	C CAPACITOR		
	C 213	NCB21HK-393X	C CAPACITOR		
	C 221	NCS21HJ-331X	C CAPACITOR		
	C 301	QEKJ1AM-107Z	E CAPACITOR	100MF 20% 10V	
	C 302	NCB21HK-393X	C CAPACITOR		
	C 303	QEKJ0JM-227Z	E CAPACITOR	220MF 20% 6.3V	
	C 304	QEKJ1CM-226Z	E CAPACITOR	22MF 20% 16V	
	C 305	QEKJ1CM-226Z	E CAPACITOR	22MF 20% 16V	
	C 306	QEKJ1CM-226Z	E CAPACITOR	22MF 20% 16V	
	C 307	NCB21HK-103X	C CAPACITOR		
	C 308	NCB21HK-152X	C CAPACITOR		
	C 310	NCB21HK-223X	C CAPACITOR		
	C 313	QEKJ1AM-107Z	E CAPACITOR	100MF 20% 10V	
	C 314	QCZ0202-155Z	ML C CAPACITOR	1.5MF	
	C 316	QFG32AJ-223Z	PP CAPACITOR	.022MF 5% 100V	
	C 319	QFLM1HJ-472Z	M CAPACITOR	4700PF 5% 50V	
	C 331	QEKJ1CM-476Z	E CAPACITOR	47MF 20% 16V	
	C 371	QEKJ1EM-475Z	E CAPACITOR	4.7MF 20% 25V	
	C 374	QEKJ1AM-107Z	E CAPACITOR	100MF 20% 10V	
	C 376	NCB21HK-103X	C CAPACITOR		
	CN 31	QGF1205F1-06	CONNECTOR	PRI/HEAD	
	CN 32	QGB2011M1-10	B TO B CONNECTO	PRI/MECHA	
	CN 33	QGF1205F1-09	CONNECTOR	PRI/MICON	
	CN 34	QGF1201F3-10	CONNECTOR	PRI/AMP	
	D 375	MA3051/M/-X	Z DIODE		
	FW 31	QUM024-06A2Z3	PARA RIBON WIRE		
	IC 31	BA3126N	IC	HEAD SW	
	IC 32	AN7317	IC	PB&REC	
	IC 33	BU4094BCF-X	IC		
	L 301	QQR1292-001	BIAS COIL		
	L 303	QQL244K-100Z	INDUCTOR		
	Q 302	KTC3203/Y/-T	TRANSISTOR	OSC	
	Q 305	KTC3203/Y/-T	TRANSISTOR	SW	
	Q 321	UN2213-X	TRANSISTOR	BUFFER	
	Q 371	KTA1271/OY/-T	TRANSISTOR	MOTER+B	
	Q 372	UN2212-X	TRANSISTOR		
	Q 375	2SB562/C/-T	TRANSISTOR	SOLENOID DRIVE	
	Q 376	2SD601A/QR/-X	TRANSISTOR		
	R 101	NRSA63J-220X	MG RESISTOR		
	R 102	NRSA63J-182X	MG RESISTOR		

△	Item	Parts number	Parts name	Remarks	Area
	R 103	NRSA63J-242X	MG RESISTOR		
	R 104	NRSA63J-122X	MG RESISTOR		
	R 105	NRSA63J-104X	MG RESISTOR		
	R 106	NRSA63J-332X	MG RESISTOR		
	R 107	NRSA63J-123X	MG RESISTOR		
	R 108	NRSA63J-562X	MG RESISTOR		
	R 109	NRSA63J-102X	MG RESISTOR		
	R 110	NRSA63J-272X	MG RESISTOR		
	R 111	NRSA63J-363X	MG RESISTOR		
	R 112	NRSA63J-222X	MG RESISTOR		
	R 116	NRSA63J-102X	MG RESISTOR		
	R 121	NRSA63J-153X	MG RESISTOR		
	R 122	NRSA63J-102X	MG RESISTOR		
	R 201	NRSA63J-220X	MG RESISTOR		
	R 202	NRSA63J-182X	MG RESISTOR		
	R 203	NRSA63J-242X	MG RESISTOR		
	R 204	NRSA63J-122X	MG RESISTOR		
	R 205	NRSA63J-104X	MG RESISTOR		
	R 206	NRSA63J-332X	MG RESISTOR		
	R 207	NRSA63J-123X	MG RESISTOR		
	R 208	NRSA63J-562X	MG RESISTOR		
	R 209	NRSA63J-102X	MG RESISTOR		
	R 210	NRSA63J-272X	MG RESISTOR		
	R 211	NRSA63J-363X	MG RESISTOR		
	R 212	NRSA63J-222X	MG RESISTOR		
	R 216	NRSA63J-102X	MG RESISTOR		
	R 221	NRSA63J-153X	MG RESISTOR		
	R 222	NRSA63J-102X	MG RESISTOR		
	R 301	NRS181J-221X	MG RESISTOR		
	R 303	NRSA63J-393X	MG RESISTOR		
	R 304	NRS181J-101X	MG RESISTOR		
	R 310	QRJ146J-4R7X	UNF C RESISTOR	4.7 5% 1/4W	
	R 313	NRSA63J-2R2X	MG RESISTOR		
	R 314	NRSA63J-153X	MG RESISTOR		
	R 315	NRSA63J-101X	MG RESISTOR		
	R 327	NRSA63J-474X	MG RESISTOR		
	R 335	NRSA63J-152X	MG RESISTOR		
	R 336	NRSA63J-472X	MG RESISTOR		
	R 337	NRSA63J-332X	MG RESISTOR		
	R 338	NRSA63J-392X	MG RESISTOR		
	R 339	NRSA63J-222X	MG RESISTOR		
	R 340	NRS181J-391X	MG RESISTOR		
	R 341	NRSA63J-123X	MG RESISTOR		
	R 342	NRSA63J-203X	MG RESISTOR		
	R 343	NRSA63J-183X	MG RESISTOR		
△	R 353	QRJ146J-100X	UNF C RESISTOR	10 5% 1/4W	
	R 371	NRSA63J-123X	MG RESISTOR		
	R 372	NRSA63J-102X	MG RESISTOR		
	R 375	NRSA02J-151X	MG RESISTOR	1/8W	
	R 376	NRSA63J-472X	MG RESISTOR		
	VR 31	QVP0008-203Z	SEMI V RESISTOR	BIAS ADJ	
	VR 37	QVP0008-103Z	SEMI V RESISTOR	TAPE SPEED ADJ	

■ Electrical parts list (Cassette switch board) Block No. 08

△	Item	Parts number	Parts name	Remarks	Area
	CN 1	QGB2011L1-10	B TO B CONNECTO		
	D 1	1T3-T2	SI DIODE		
	IC 1	SG-105F3-BB,C	PHOTO SENSER		
	P 1	QNZ0104-001	POST PIN		
	SW 1	QSW0832-001	LEAF SWITCH	R.REC	
	SW 2	QSW0832-001	LEAF SWITCH	TAPE	
	SW 5	QSW0832-001	LEAF SWITCH	F.REC	
	SW 6	QSW0859-001	LEVER SWITCH		

Packing materials and accessories parts list

Block No.

M	3	M	M
---	---	---	---

Block No.

M	5	M	M
---	---	---	---

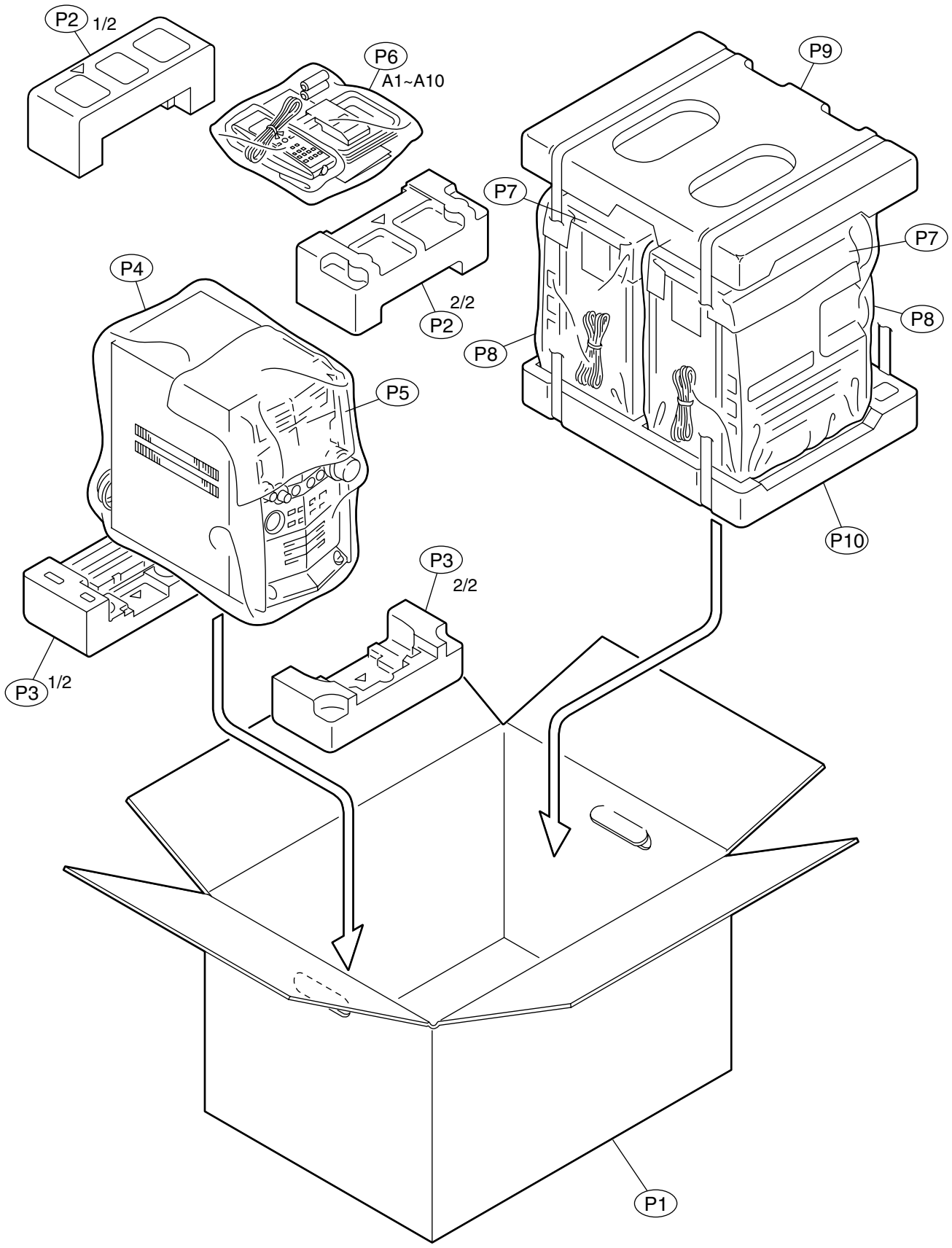

Parts list (Packing)

Block No. M3MM

△	Item	Parts number	Parts name	Q'ty	Description	Area
	P 1	GV20175-001A	PACKING CASE	1		J
		GV20175-003A	PACKING CASE	1		C
	P 2	GV10118-001A	TOP CUSHION	1		
	P 3	GV10119-001A	BOTTOM CUSHION	1		
	P 4	QPC06507015P	POLY BAG	1		
	P 5	GV40168-007A	SHEET	1		
	P 6	QPC02503515P	POLY BAG	1		
	P 7	138764501088	MIRROR MAT	2	FOR SPEAKER	
	P 8	138737001089	POLY BAG	2	FOR SPEAKER	
	P 9	139764931064	TOP CUSHION	1	FOR SPEAKER	
	P 10	139764931065	BOTTOM CUSHION	1	FOR SPEAKER	

Parts list (Accessories)

Block No. M5MM

△	Item	Parts number	Parts name	Q'ty	Description	Area
	A 1	GVT0077-001A	INST.BOOK	1	ENG	J
		GVT0077-002A	INST.BOOK	1	ENG,FRE	C
	A 2	GV40325-001A	NOTICE/AVIS	1		
	A 3	YU20333	SAFETY INST.	1		
	A 4	BT-51028-1	REGIST CARD	1		J
	A 5	QAL0014-001	AM LOOP ANT	1		
	A 6	EWP503-001	ANT.WIRE	1		
	A 7	RM-SHXZ3A	REMOCON	1		
	A 8	-----	BATTERY	2		
	A 9	BT-52006-1	WARRANTY CARD	1		C
	A 10	BT-20071B	SERVICE NETWORK	1		C