

# JVC

## SERVICE MANUAL

MODEL  
**JA-S11G**  
STEREO INTEGRATED AMPLIFIER



No. 2429  
NOV. 1977

## Contents

	Page
Specifications . . . . .	2
Removal of Top Cover and Bottom Plate . . . . .	3
Main Parts Location . . . . .	3
Exploded Views and Part Numbers	
(1) Front . . . . .	5
(2) Rear . . . . .	6
(3) Chassis Base . . . . .	7
(4) Power Transformer . . . . .	8
Special Parts List with Specified Numbers by Areas (table 2) . . . . .	8
Printed Circuit Board Ass'y and Parts List	
(1) TXX-28 (TAP-257 and TAC-413) Main and Tone Control P.C. Board Ass'y . . . . .	9
(2) TPS-69 AC Primary P.C. Board Ass'y . . . . .	13
(3) TPS-70 AC Primary P.C. Board Ass'y . . . . .	13
JA-S11G Schematic Diagram . . . . .	14
JA-S11G Schematic Diagram for U.S.A. and Canada . . . . .	15
Packing Materials . . . . .	16
Accessories List . . . . .	16

**Note:**

When replacing the parts marked with  $\triangle$ , be sure to use the designated parts to ensure safety.

## Specifications

### Power Amplifier Section

Output Power (both channels driven)	: 30 watts per channel, min. RMS into 8 ohms, from 20Hz – 20kHz with no more than 0.1% total harmonic distortion 33 watts per channel into 8 ohms at 1kHz. THD = 0.1%
Total Harmonic Distortion (at 30W) (both channels driven)	: 0.05% at 1kHz
Intermodulation distortion	: 0.1% at rated output
Load Impedance	: 4 $\Omega$ – 16 $\Omega$ (SYSTEM-1 or SYSTEM-2) 8 $\Omega$ – 16 $\Omega$ (SYSTEM-1 + 2)
Damping Factor	: More than 30 at 8 $\Omega$ (20Hz – 20kHz)

### Pre-Amplifier Section

Input Sensitivity/Impedance	: PHONO 2.5mV/47k $\Omega$ AUX, TUNER, TAPE PLAY 150mV/50k $\Omega$
Output Level	: TAPE REC.-1, -2 150mV DIN REC. 30mV
Phono Equalizer Deviation	: $\pm$ 0.5dB from RIAA curve (25Hz – 15kHz)
Phono Overload	: 150mV (RMS) at 1kHz, 420mV (P-P)
Signal to Noise Ratio	: PHONO 65dB (RMS) AUX – 85dB (RMS)
Frequency Response	: AUX, TUNER, TAPE PLAY 25Hz – 40kHz $\begin{matrix} +0 \\ -1 \end{matrix}$ dB
Loudness Control (at –30dB Volume Control)	: +6dB at 100Hz +4dB at 10kHz
Tone Controls	: Bass $\pm$ 8dB at 100Hz Treble $\pm$ 8dB at 10kHz

Power Source : Refer to table 1 listed below

Power Consumption : Refer to table 1 listed below

Dimensions : 5-3/32"(H) x 15-11/32"(W) x 13"(D)  
(15.2cm x 39.0cm x 33.0cm)

Weight : 15.4 lbs. (7.0kg)

	U.K. Australia	European continent Scandinavian countries Finland	U.S.A., Canada	Other countries
Power supply	AC 240V, 50Hz	AC 220V, 50Hz	AC 120V, 60Hz	AC 100/120/220/240V, 50/60Hz
Power consumption	300 watts	235 watts	150 watts	235 watts

(Table 1)

## Removal of Top Cover and Bottom Plate

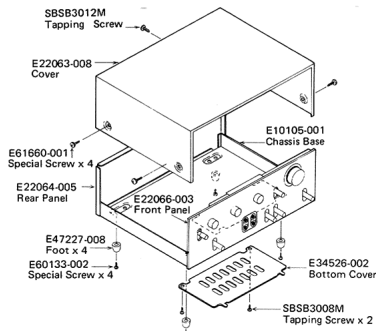

Fig. 1

## Main Parts Location

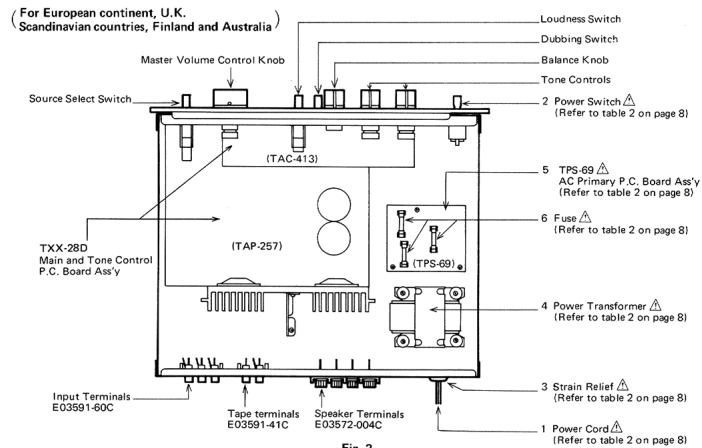

Fig. 2

(For U.S.A. and Canada)

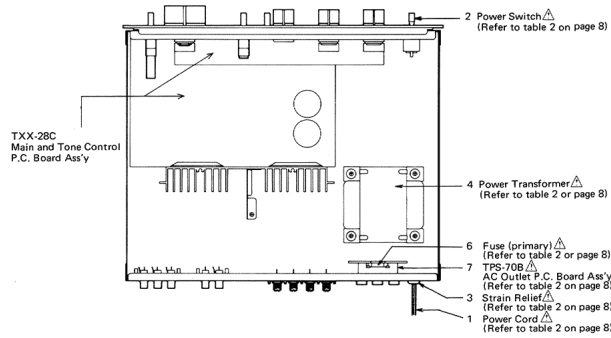
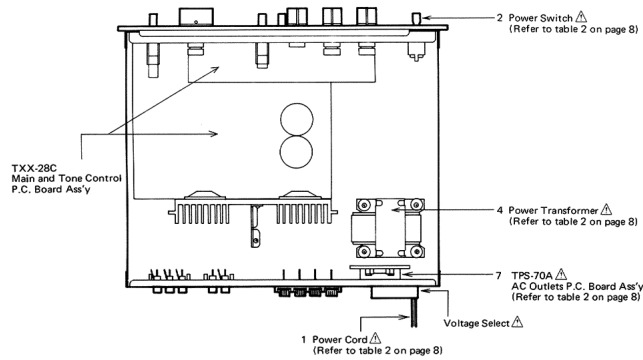

Fig. 3

(For Other countries)



NOTE  $\Delta$  : SAFETY PARTS

Fig. 4

## Exploded Views and Part Numbers

(1) Front

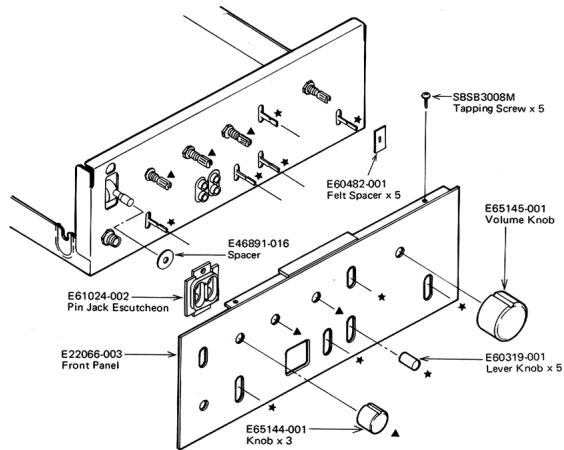

Fig. 5

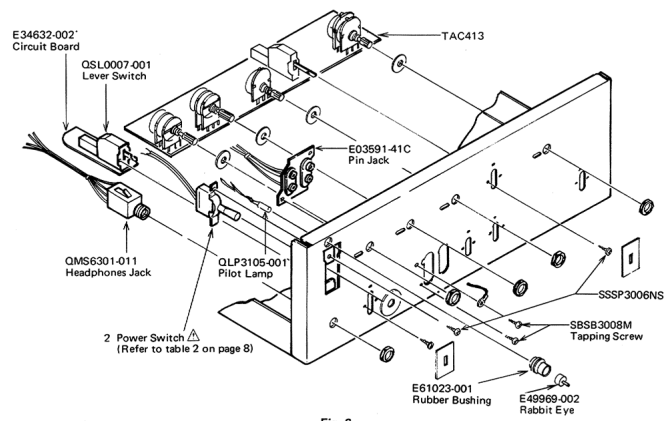

Fig. 6

NOTE ▲ : SAFETY PARTS

JA-S11G  
No. 2429

(2) Rear

(For European continent, U.K.  
Scandinavian countries, Finland and Australia)

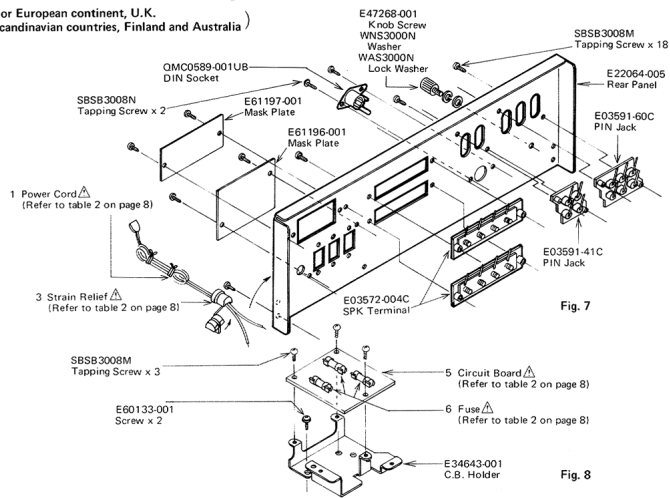

(For U.S.A. and Canada)

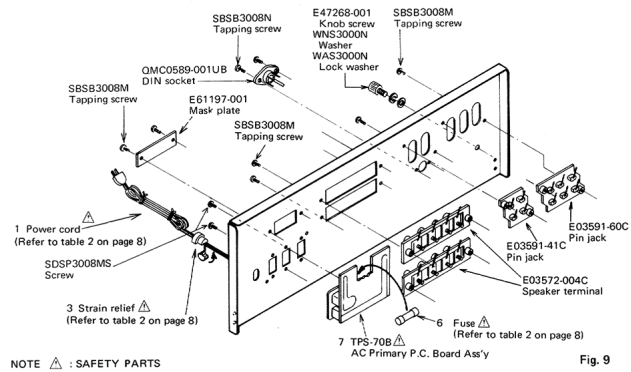

NOTE  $\Delta$  : SAFETY PARTS

(For Other countries)

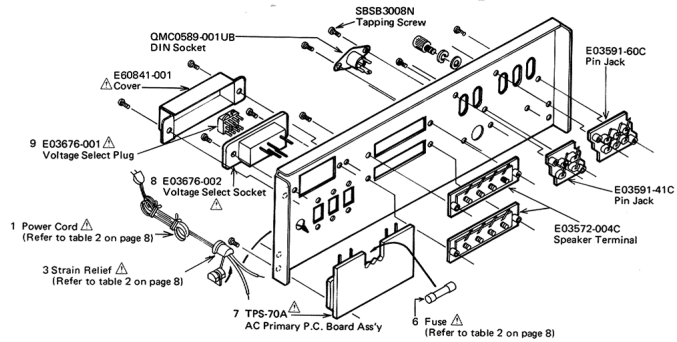

Fig. 10

(3) Chassis Base

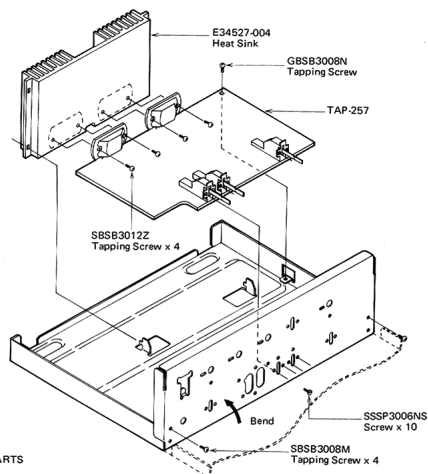

Fig. 11

JA-S11G  
No. 2429



(4) Power Transformer

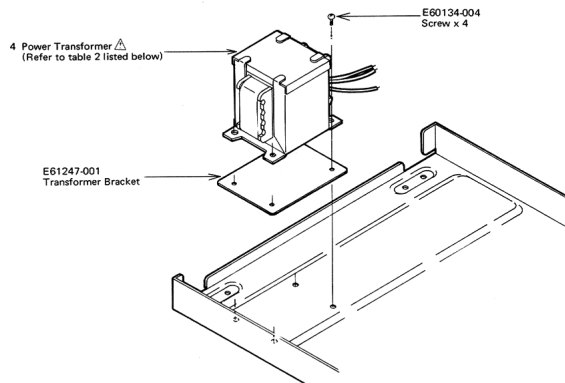

Fig. 12

## Special Parts List with Specified Numbers by Areas

Page	Item No.	Description	Part Number				
			for U.K.	For European continent Scandinavian countries Finland	for Australia	for U.S.A., Canada	for Other countries
3 ~ 8	1	Power Cord	QMP9017-008BS	QMP3910-244	QMP2610-200	QMP1200-244	QMP1200-244
3 ~ 8	2	Power Switch	QSL2235-103BS	QSL2235-103	QSL2235-103	QSL1135-012	QSL1135-011G
3 ~ 8	3	Strain Relief	QHS3876-162BS	QHS3876-162	QHS3876-162	QHS3876-162	QHS3876-162
3 ~ 8	4	Power Transformer	E03075-33CBS	E03075-33C	E03075-33C	E03075-33D	E03075-33B
3 ~ 8	5	Circuit Board	E34633-001BS	E34633-001	E34633-001	—	—
3 ~ 8	6	Fuse (Primary)	QMF51A2-2R0BS (2AT)	QMF51A2-2R0 (2AT)	QMF51A2-2R0 (2AT)	QMF61U1-3R0 (3A 125V)	QMF60S1-3R3 (3.3A 100,120V) QMF60S1-1R6 (1.8A 220,240V)
		(Secondary)	QMF51A2-3R15BS (3.15AT)	AMF51A2-3R15 (3.15AT)	QMF51A2-3R15 (3.15AT)	—	—
3 ~ 8	7	AC outlet P.C./ Board Ass'y	—	—	—	TPS-70B	TPS-70A
3 ~ 8	8	Voltage Select Plug	—	—	—	—	E03676-002
3 ~ 8	9	Voltage Select Socket	—	—	—	—	E03676-001

(Table 2)

NOTE : SAFETY PARTS

# Printed Circuit Board Ass'y and Parts List

(1) TXX-28 (TAP-257 and TAC-413)  
Main and Tone Control P.C. Board Ass'y

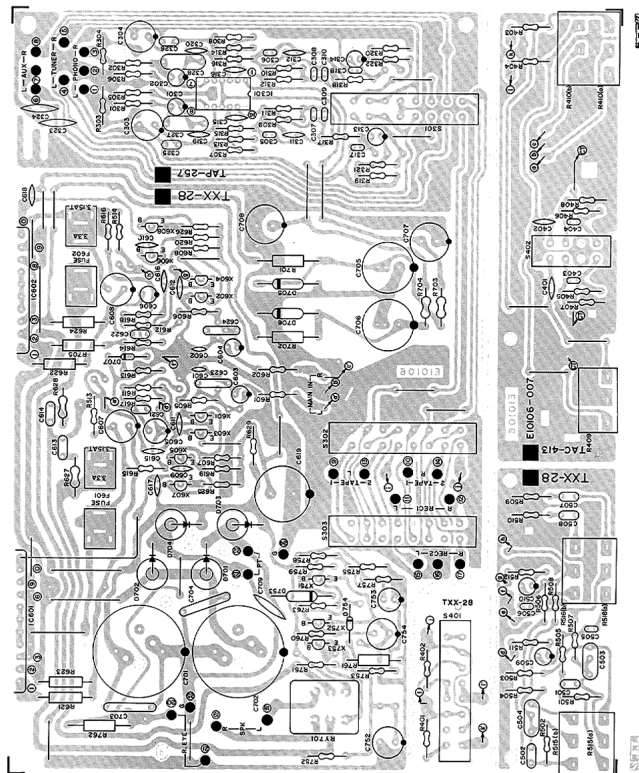

**Transistors**

Item No.	Part No.	Rating		Description	Maker
		Pc	fr		
X601~604	2SC1775AV(F1)	300mW	200MHz	Silicon Transistor	Hitachi
X605,606	2SA872AV(E)	300mW	120MHz	-	"
X607,608	2SB560(E)	750mW	100MHz	-	Sanyo
X751,752	2SC1775AV(F)	300mW	200MHz	-	Hitachi
X753	2SD438(E)	750mW	100MHz	-	Sanyo

**Integrated Circuits**

Item No.	Part No.	Rating	Description	Maker
IC301	HA1452W		I.C. (for Equalizer Amp.)	Hitachi
IC601,602	STK0040		I.C. (for Power Amp.)	Sanyo

**Diodes**

Item No.	Part No.	Rating		Description	Maker
D701~704	MR-1			Silicon Diode	Sanken
D705,706	QEB01-15Z	15V	1W	Zener Diode	Fuji
D707	WZ-071A	7V	500mW	-	JRC
D753	1SB01-02			Silicon Diode	Fuji
D754	1S2473			-	Toyo Dengu

**Resistors**

Item No.	Part No.	Rating			Description
R301,302	QRD141J-222	2.2k $\Omega$	$\pm 5\%$	$\frac{1}{4}W$	Carbon Resistor
R303~306	QRD141J-104	100k $\Omega$	"	"	"
R307,308	QRD141J-821	82 $\Omega$	"	"	"
R309,310	QRD141J-393	39k $\Omega$	"	"	"
R311,312	QRD141J-474	470k $\Omega$	"	"	"
R313,314	QRD141J-564	560k $\Omega$	"	"	"
R315,316	QRD141J-182	1.8k $\Omega$	"	"	"
R317,318	QRD141J-470	47 $\Omega$	"	"	"
R319,320	QRD141J-104	100k $\Omega$	"	"	"
R321,322	QRD141J-471	470 $\Omega$	"	"	"
R403,404	QRD141J-472	4.7k $\Omega$	"	"	"
R405,406	QRD141J-683	68k $\Omega$	"	"	"
R407,408	QRD141J-223	22k $\Omega$	"	"	"
R409	QV88A2W-6F5E	250k $\Omega$ (W)			Variable Resistor (Balance)
R410	QVCA2B-9F5	250k $\Omega$ (B)			(Master Volume)
R501,502	QRD141J-823	82k $\Omega$	$\pm 5\%$	$\frac{1}{4}W$	Carbon Resistor
R503,504	QRD141J-182	1.8k $\Omega$	"	"	"
R505,506	QRD141J-123	12k $\Omega$	"	"	"
R507,508	QRD141J-182	1.8k $\Omega$	"	"	"
R509,510	QRD141J-561	560 $\Omega$	"	"	"
R511,512	QRD141J-562	5.6k $\Omega$	"	"	"
R513,514	QRD141J-472	4.7k $\Omega$	"	"	"
R515,516	QVC3A2C-215	100k $\Omega$ (C)			Variable Resistor (Tone)
R601,602	QRD141J-222	2.2k $\Omega$	$\pm 5\%$	$\frac{1}{4}W$	Carbon Resistor
R605,606	QRD141J-184	180k $\Omega$	"	"	"
R607,608	QRD141J-182	1.8k $\Omega$	"	"	"
R611,612	QRD141J-681	680 $\Omega$	"	"	"
R613,614	QRD141J-683	68k $\Omega$	"	"	"

Item No.	Part No.	Rating			Description
R617,618	QRD141J-681	680Ω	±5%	¼W	Carbon Resistor
R619,620	QRD141J-182	1.8kΩ	"	"	"
R621,622	QRD126J-392	3.9kΩ	"	½W	Uninflammable Carbon Resistor
R623,624	QRD126J-222	2.2kΩ	"	"	"
R627,628	QRD126J-4R7	4.7Ω	"	½W	Uninflammable Carbon Resistor $\Delta$
R629	QRD126J-470	47Ω	"	"	" $\Delta$
R701,702	QRG027J-821	820Ω	"	2W	Oxide Metal Film Resistor
R703,704	QRD141J-820	82Ω	"	¼W	Carbon Resistor
R705	QRD126J-332	3.3kΩ	"	½W	Uninflammable Carbon Resistor
R751,752	QRD141J-563	56kΩ	"	¼W	Carbon Resistor
R753	QRD141J-223	22kΩ	"	"	"
R755	QRD141J-393	39kΩ	"	"	"
R757	QRD141J-103	10kΩ	"	"	"
R758	QRD141J-564	560kΩ	"	"	"
R759	QRD141J-334	330kΩ	"	"	"
R760	QRD141J-823	82kΩ	"	"	"
R761	ORG017J-181	180Ω	"	1W	Oxide Metal Film Resistor
R762	ORG027J-681	680Ω	"	2W	"
R763	QRD141J-104	100kΩ	"	¼W	Carbon Resistor

NOTE  $\Delta$  : SAFETY PARTS

#### Capacitors

Item No.	Part No.	Rating			Description
C301,302	QEB41EM-475	4.7μF	±20%	25V	L.L.C. Electrolytic Capacitor
C303,304	QEB41EM-336	33μF	"	50V	"
C305,306	QFM41HJ-182	1800pF	±5%	"	Mylar Capacitor
C307~310	QFM41HJ-332	3300pF	"	"	"
C311,312	QCS11HJ-820	82pF	"	"	Ceramic Capacitor
C313,314	QEB41EM-225	2.2μF	±20%	25V	L.L.C. Electrolytic Capacitor
C315,316	QCS11HJ-151	150pF	±5%	50V	Ceramic Capacitor
C317,318	QFM41HK-332	3300pF	±10%	"	Mylar Capacitor
C319,320	QCS11HJ-101	100pF	±5%	"	Ceramic Capacitor
C323,324	QCF11HP-473	0.047μF	+100%-0%	"	"
C401,402	QCS11HJ-181	180pF	±5%	"	"
C403,404	QFM41HK-153	0.015μF	±10%	"	Mylar Capacitor
C501,502	QFM41HK-333	0.033μF	"	"	"
C503,504	QFM41HK-224	0.22μF	"	"	"
C505,506	QFM41HK-222	2200pF	"	"	"
C507,508	QFM41HK-223	0.022μF	"	"	"
C509,510	QEW41CA-106	10μF	+100%-10%	16V	Electrolytic Capacitor
C601,602	QCS11HJ-470	47pF	±5%	50V	Ceramic Capacitor
C603,604	QEB41EM-475	4.7μF	±20%	25V	L.L.C. Electrolytic Capacitor
C605,606	QEW41EA-476	47μF	+100%-10%	"	Electrolytic Capacitor
C607,608	QEW41HA-476	47μF	+100%-10%	50V	Electrolytic Capacitor
C609,610	QCS11HJ-150	15pF	±5%	"	Ceramic Capacitor
C611,612	QCS11HJ-181	180pF	"	"	"
C613,614	QFM41HK-473	0.047μF	±10%	"	Mylar Capacitor
C615,616	QCS11HJ-470	47pF	±5%	"	Ceramic Capacitor
C617,618	QCS11HJ-151	150pF	"	"	"
C619	QEW41HA-227	220μF	+100%-10%	"	Electrolytic Capacitor
C701,702	QEW71GH-688	6800μF	+50%-10%	42V	"
C705,706	QEW41CA-107	100μF	+100%-10%	16V	"
C707,708	QEW41CA-477	470μF	"	"	"
C709	QCF12HP-103	0.01μF	+100%-0%	500V	Ceramic Capacitor
C751	QEW41CA-107	100μF	+100%-10%	10V	Electrolytic Capacitor
C753	QEW41HA-475	4.7μF	"	50V	"
C754	QEW41AA-107	100μF	"	10V	"

JA-S11G  
No. 2429

Others

Item No.	Part No.	Rating	Description
S301	QSL4312-004		Lever Switch (Source)
S302,303	QSL4312-003		" (Tape)
S402	QSL2212-004		" (Loudness)
RY701	ESK1D24-216		Tab
	E43727-002		Fuse Clip
	E48965-002		

Transistor, IC and Diode Lead Identification

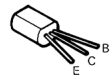
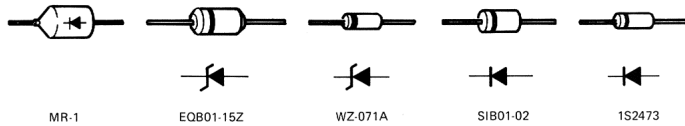

2SC1775AV(F)  
2SC1775AV(F1)  
2SA872AV(E)  
2SB560(E or D)  
2SD438(E)

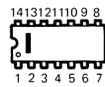

HA1452W

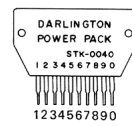

STK0040

IC Blocks

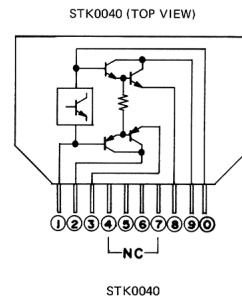
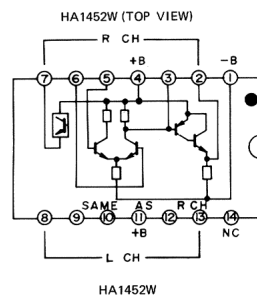

(2) TPS-69 AC Primary P.C. Board Ass'y  $\Delta$

( For European continent, U.K.  
Scandinavian countries, Finland and Australia )

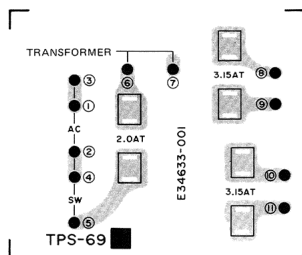

Fig. 14

(3) TPS-70 AC Primary P.C. Board Ass'y  $\Delta$

(For U.S.A., Canada and Other countries)

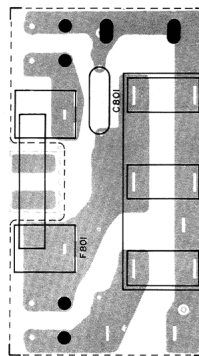

Fig. 15

TPS-69 ( For European continent, U.K.  
Scandinavian countries, Finland and Australia )

Item No.	Part No.	Rating	Description
	E43727-002 QHW2052-001 E48965-002		Tab Wire Clamp Fuse Clip

TPS-70A (For Other countries)

Item No.	Part No.	Rating	Description
J4	QMC0637-001 E03675-003 E43727-001 E40130		AC Socket $\Delta$ Fuse Clip Tab -

TPS-70B (For U.S.A. and Canada)

Item No.	Part No.	Rating		Description
J4	QMC0637-001 E03675-003 E43727-001 E40130			AC Socket $\Delta$ Fuse Clip Tab. Tab.
C801	QFH72BM-103M	0.01 $\mu$ F	AC125V	Metalized Mylar Capacitor $\Delta$

JA-S11G  
No. 2429

NOTE  $\Delta$  : SAFETY PARTS

**A** **B** **C** **D** **E** **F**

- Notes:**
1. Voltage values in  $\square$  and  $\square$  are measured with a tester (impedance 20 k $\Omega$ /V).
  2. Voltage values in  $\square$  are measured with a VTVM.
  3. Voltage values in  $\square$  are positive.
  4. Voltage values in  $\square$  are negative.
  5.  $\square$  indicates positive B power supply.
  6.  $\square$  indicates negative B power supply.
  7.  $\square$  indicates signal path.
  8. When replacing the parts in the darkened areas ( $\square$ ) and those parts marked with  $\Delta$ , be sure to use the designated parts to ensure safety.
  9. This is the standard circuit diagram. The design and constants are subject to change without notice.

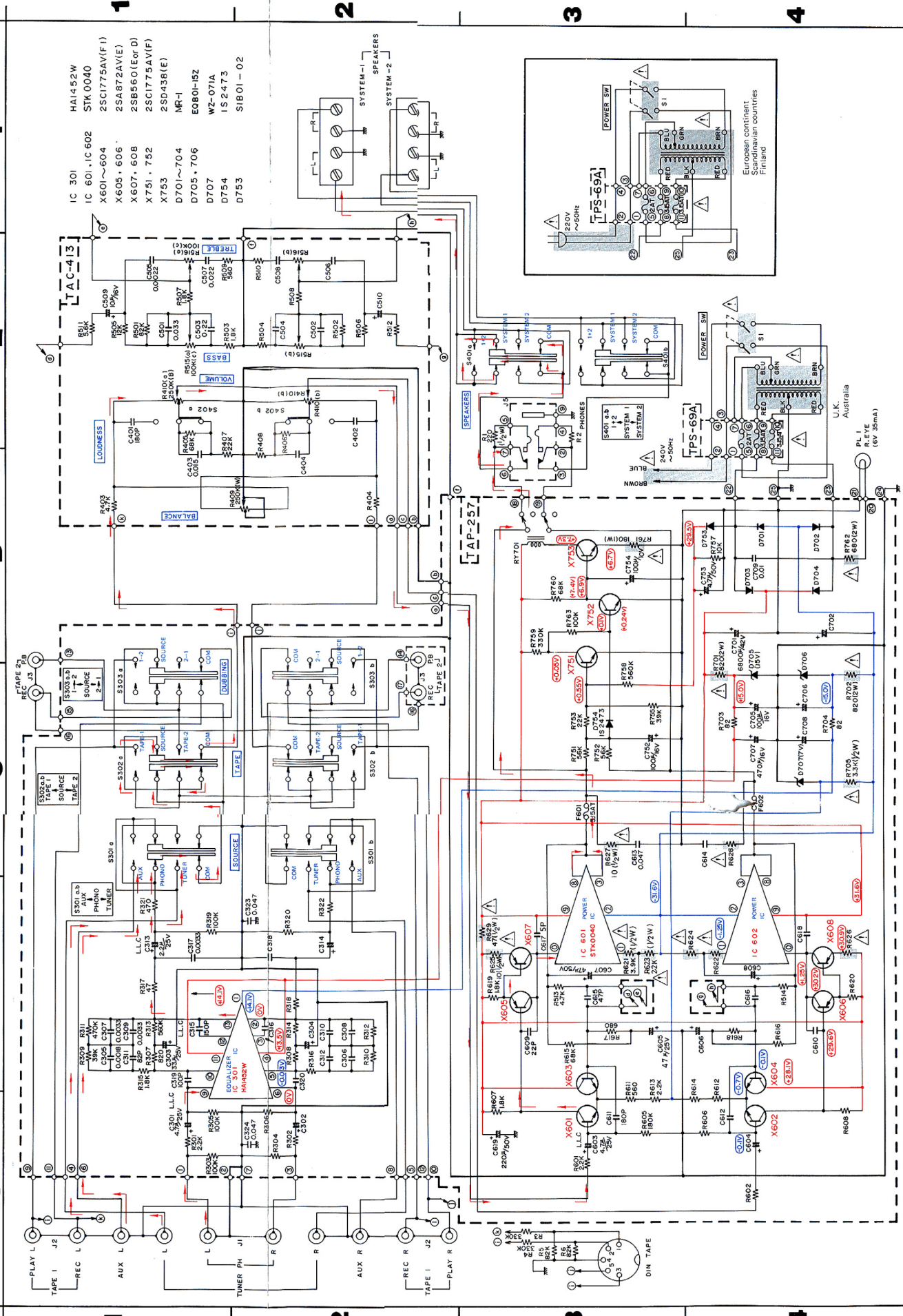

- IC 301**  
HAI452W  
IC 601, IC 602  
STK 0040  
X601~604  
25C1775AV(F I)  
X605, 606  
25A872AV(E)  
X607, 608  
25B550(E or D)  
X751, 752  
25C1775AV(F)  
X753  
25D438(E)  
MR-1  
D701~704  
E0B01-152  
D705, 706  
WZ-071A  
D707  
D754  
IS 2473  
SIB011-02

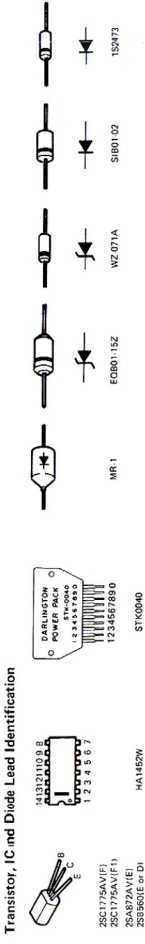
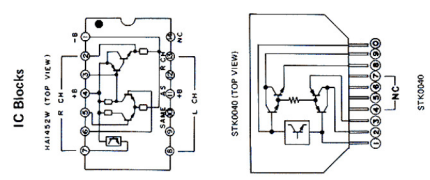

Printed Circuit Board Assy Locations

P.C. Board Assy	Description	Page
TXX-28 (TAP-257 & TAC-413)	Main and Tone Control P.C. Board Assy	9
TPS-69	AC Primary P.C. Board Assy	13
TPS-70	AC Primary P.C. Board Assy	13



- Notes:
1. Voltage values in  $\square$  and  $\square$  are measured with a tester (impedance 20 k $\Omega$ /V).
  2. Voltage values in  $\square$  are measured with a VTVM.
  3. Voltage values in  $\square$  are positive.
  4. Voltage values in  $\square$  are negative.
  5.  $\square$  indicates positive B power supply.
  6.  $\square$  indicates negative B power supply.
  7.  $\square$  indicates signal path.
  8. When replacing the parts in the darkened areas ( $\square$ ), be sure to use the designated parts to ensure safety.
  9. This is the standard circuit diagram.
- The design and constants are subject to change without notice.

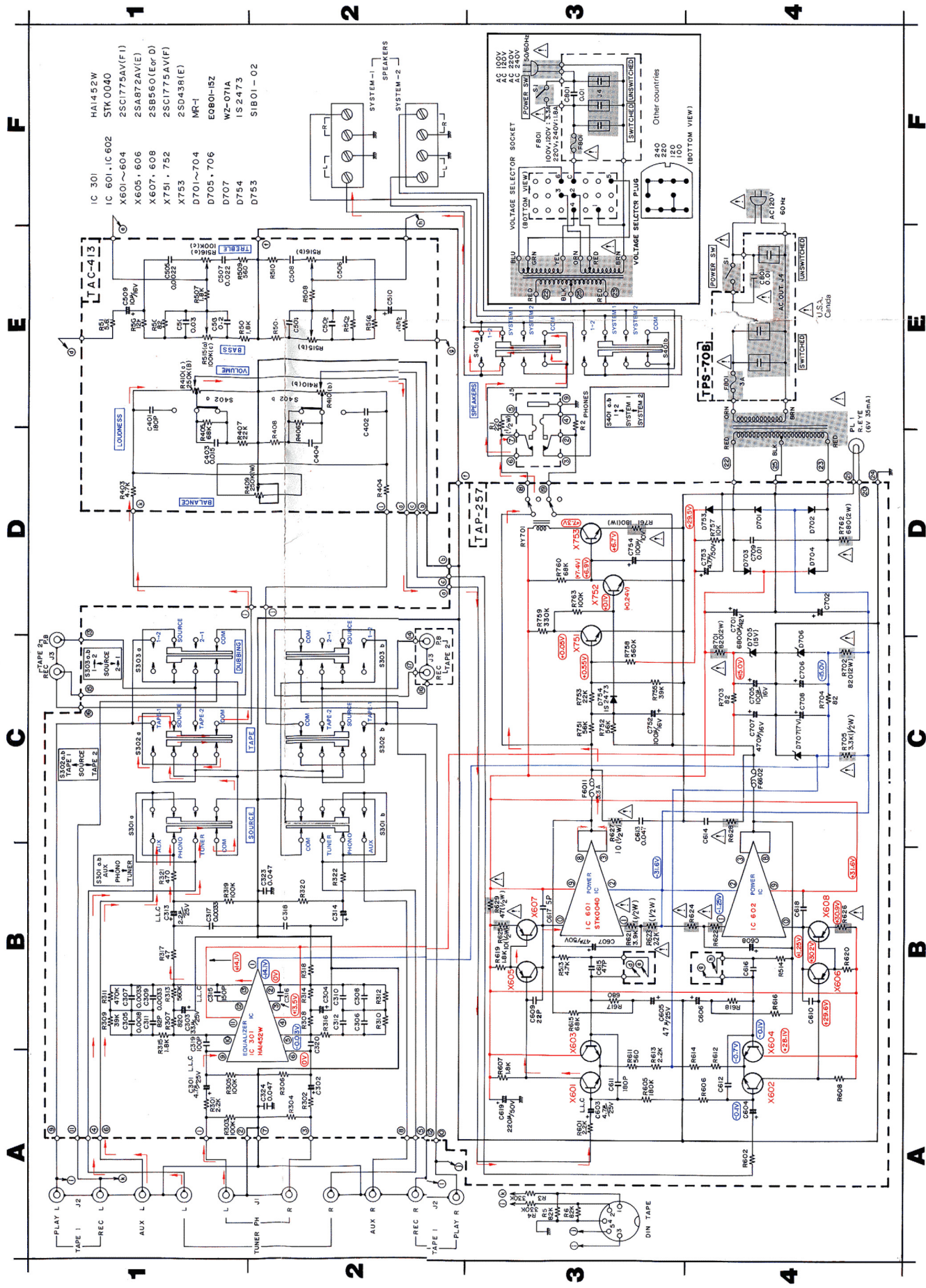



**Differences between Models intended for Different Areas**

	European continent Scandinavian countries Finland	U.K. Australia	U.S.A. Canada	Other areas
Power supply	AC 220V, 50Hz	AC 240V, 50/60Hz	AC 120V, 60Hz	AC100–240V selectable, 50/60Hz
Power consumption	235 watts	300 watts	150 watts	235 watts
Line voltage selector	Not fitted	Not fitted	Not fitted	Fitted
Power outlets	Not fitted	Not fitted	Fitted	Fitted

This amplifier has been preset to the line voltage in the areas where it is to be sold as shown in the above table. To conform with local safety standards in some countries, power outlets may not be provided.

(Table 3)

**Packing Materials (Refer to table 4)**

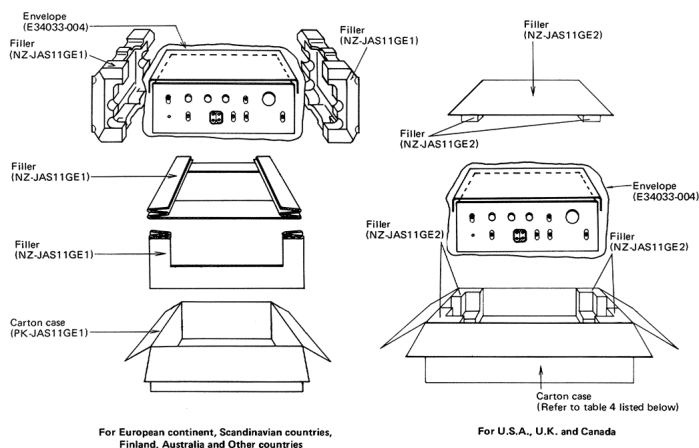

Description	Part Number		
	for U.K. U.S.A.	for Canada	for European continent Scandinavian countries Finland Australia Other countries
Filler	NZ-JAS11GE2	NZ-JAS11GE2	NZ-JAS11GE1
Envelope	E34033-004	E34033-004	E34033-004
Carton case	PK-JAS11GE2	PK-JAS11GEC2	PK-JAS11GE1

(Table 4)

## Accessories List

Part No.	Part Name	Remarks	Q'ty
E30580-524E	Instruction Book		1
BT20032	JVC Warranty Card	for U.S.A. only	1
BT20023	Service Procedure	"	1
BT20024B	Special Reply Card	"	1
BT20025B	JVC Warranty Card	for Canada only	1
E41202-2	Envelope	for Accessories	1
QMF60S1-3R3	Fuse $\Delta$	3.3A: 100/120V	1
QMF60S1-1R8	- $\Delta$	1.8A: 220/240V	1
E64208-001	Envelope	for Fuse } Other areas	1

NOTE  $\Delta$  : SAFETY PARTS

# JVC

VICTOR COMPANY OF JAPAN, LIMITED  
STEREO DIVISION

Printed in Japan  
7011-V