



SERVICE MANUAL



MODEL JL-A3

4-CHANNEL SYSTEM PLAYER

SPECIFICATIONS

MOTOR AND TURNTABLE

Type: Auto return/auto cut turntable
Motor: 4-Pole AC Servo-Motor
Drive System: Belt Drive System
Speeds: 33-1/3 and 45 rpm
Controllable Speed
Range: Within $\pm 3\%$ for both 33-1/3 and 45 rpm

Wow & Flutter: Less than 0.08% (WRMS)
Signal-to-Noise Ratio: Better than 55dB
Turntable Platter: 31cm (12") diameter die-cast aluminum
Platter Rise Time: One rotation (33-1/3 rpm)

TONEARM

Type: Statically-balanced tubular tonearm with TH System

CARTRIDGE

Type: Moving magnet type with diamond stylus
Frequency Response: 10 to 25,000Hz

Channel Separation: Better than 25dB (at 1kHz)
Channel Balance: Within ± 1.5 dB
Output Voltage: 2mV at 1kHz (50mm/sec.)
Recommended Stylus

Pressure: 1.5 to 2.0 grams
Compliance: 25×10^{-6} cm/dyne
Replacement Stylus: 0.5mil, diamond, DT-33S

GENERAL

Cabinet: Wood in walnut finish with free-stop, removable dust cover and vibration insulators
Power Source: AC 100V/120V/220V/240V selectable 50/60Hz
Power Consumption: 10W
Dimensions: 7-1/4 x 16-3/16 x 14-3/16 inches or 18.5 x 46 x 38cm
Weight: 18.7 lbs or 8.5kg (net) or 23.1 lbs or 10.5kg (gross)

SETTING UP

To avoid possible damage to your unit during transit, your JL-A3 has been shipped from the JVC factory with some of the parts already fixed to the wooden plinth, and others packed in separate containers. Please follow the setting-up procedures listed below carefully in order to get maximum performance from your turntable.

i Removal of Packing Elements (Fig. 1)

1. Remove the parts box (A) fixed to the motor board.
2. Remove the tow motor fixing screw (B).
3. Remove vinyl ribbon (C) and aluminium shipping tape (D).
4. Remove the tow transformer fixing screw (E).

ii Platter Assembly

1. Remove the turntable platter from its packing and carefully fit it onto the center spindle.
2. Holding the drive belt with your fingers, pass it through the shift lever and over the pulley.

iii Tonearm Assembly

1. Take the main weight out of the parts container that you removed from the motor board and fit it onto the end of the tonearm weight shaft turning it gently in the direction.
2. Mounting Cartridge

After removing the cartridge-equipped head shell from the parts container, insert the bayonet cap end into the lock ring on the front end of the tonearm and lock it firmly in position.

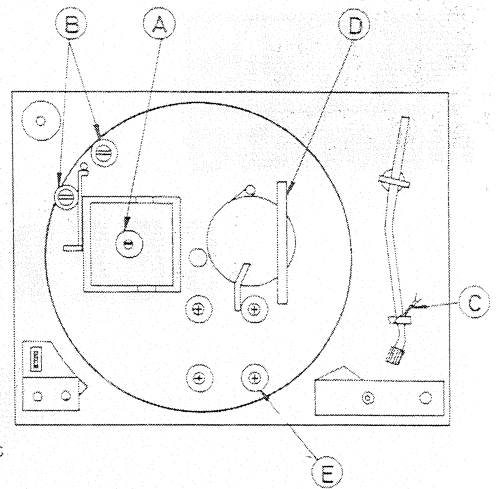

Fig. 1

NAMES OF TURNTABLE PARTS

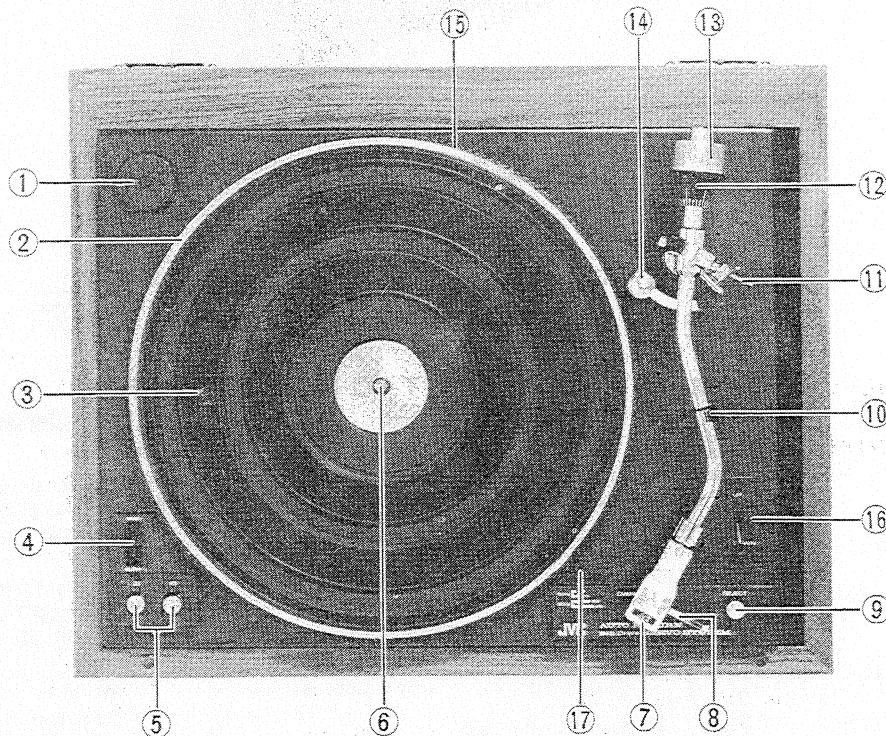

Fig. 2

- | | | |
|-------------------------|----------------------------------|----------------------------------|
| 1. EP Record Adaptor | 7. Cartridge-Equipped Head Shell | 13. Main Weight |
| 2. Turntable Platter | 8. Head Shell Hook | 14. Tonearm Lifter |
| 3. Rubber Platter Mat | 9. Reject Button | 15. Strobe (Turntable periphery) |
| 4. Fine Speed Control | 10. Tonearm Rest and Hook | 16. Cueing Lever |
| 5. Speed Select Buttons | 11. Antiskating | 17. Strobe Neon Lamp |
| 6. Center Spindle | 12. Stylus Pressure Dial | |

WHEN POWER SUPPLY IS ALTERED

Because it is fitted with an AC servomotor, the JL-A3 needs to be modified when the power supply voltage changes but not when only the frequency changes.

The illustration shows the voltage selector plug inside the JL-A3; set this so that its arrow points at the required voltage. (In the illustration it is set for 120V.)

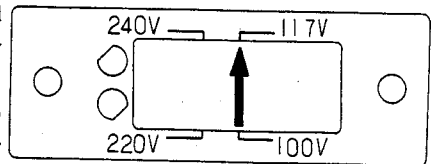

Fig. 3

OPERATION OF AUTOMECHANISMS

Change Cycle*

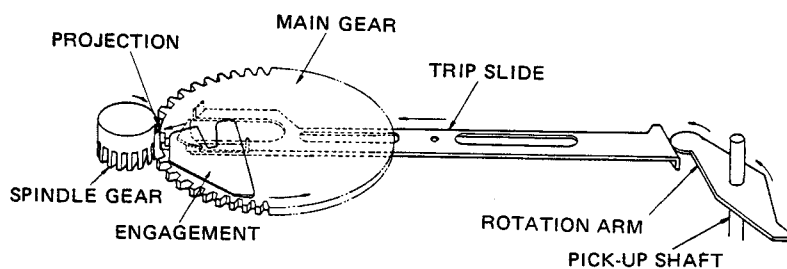

Fig. 4

1. During playing the notch in the main gear and the turntable spindle gear are positioned with respect to each other as is shown in Fig. 5 so that the main gear will not rotate when the turntable turns. The projection will be disengaged from the engagement.
2. As the pickup arm approaches the center of the record, the pickup's feed arm will push the trip slide, shifting the engagement.
3. Because it is lightly placed on the lower trip the engagement is easy to move. The relative positions of the engagement and the projection are shown in Fig. 5. Because of this when the record pitch is small, towards the end of the recorded section, the engagement only makes small advances and these are reversed by the projecting tip so that turntable spindle gear and main gear remain disengaged and the auto-return mechanism does not start to operate.
4. When the record has finished, the pickup comes to the run-out groove with a larger pitch. At this time the engagement advances more than it is reversed by the projection so that their respective positions are as shown in Fig. 7. Consequently the projection pushes the engagement and the main gear is turned. The notch moves and the turntable spindle gear becomes engaged with the main gear. This causes the lead-out* sequence to start.
5. The engagement and lower trip return to their original positions after the bottom of the lower trip comes into contact with the gear stopper just before the main gear has completed its rotation. This performs the shut-off* which marks the completion of the change cycle.
6. When the main gear ceases turning, the relative positions of the parts return to those shown in Fig. 5, with the main gear stationary even when the spindle gear is turning.

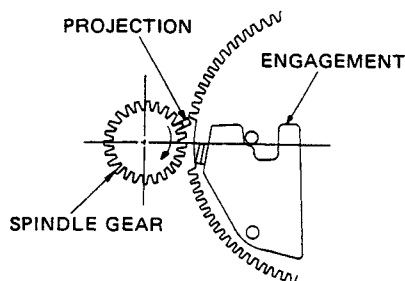

Fig. 5

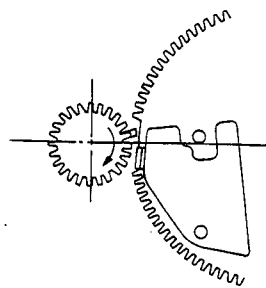

Fig. 6

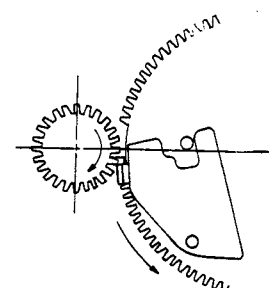

Fig. 7

Pickup Lifting and Return

1. When the record has been played, the main gear starts to turn, the trip slide moves backwards and forwards and, simultaneously, the seesaw arm moves pushing the elevator up so the pickup is lifted from the record surface.
2. Next, the trip slide moves the feed arm along the bottom of the main gear which allows the pickup to return.

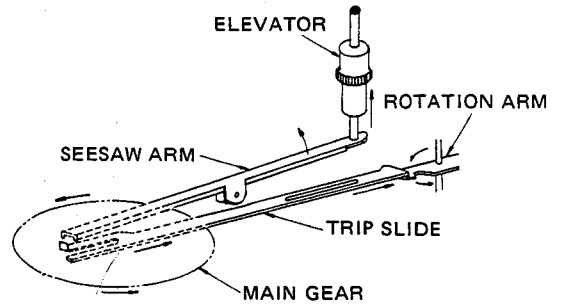

Fig. 8

ADJUSTMENT

Pickup Adjustment

1. Overhang Adjustment

The raised red circle on the panel is the adjustment indicator. The center of this circle indicates the correct overhang. No adjustment will be necessary as it was adjusted in the factory prior to shipping. However, when you replace the cartridge, adjust so that the stylus tip is exactly above this point by sliding the cartridge backwards and forwards.

2. Stylus Pressure Adjustment

- 1) Turn the main weight to the left or right so that zero balance is achieved (that is when the arm balances with the stylus tip at the level of the record surface).
- 2) When zero balance has been obtained, while holding the main weight so that it does not move, turn the stylus pressure scale ring to align "0" with the index line.
- 3) Turn the main weight clockwise to match the desired stylus pressure on the scale with the index line.

The recommended stylus pressure for the JL-A3 is 1.5 — 2g.

Note : When operating at stylus pressures of less than 1g, cancel the anti-skating device as shown in Fig. 11.

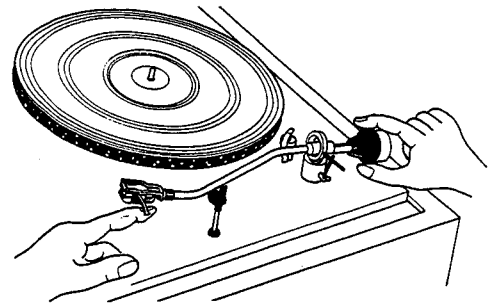

Fig. 9

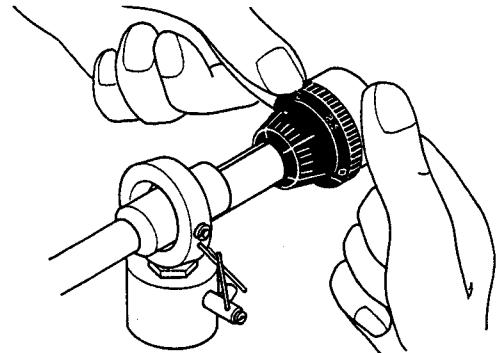

Fig. 10

Fine Adjustment of Speed

This procedure is the same for both 33-1/3rpm and 45rpm. Fine adjustment can change the speed by 2.5% either faster or slower. The patterns on the stroboscope are as shown in Fig. 13. Because of the neon lamp built into the JL-A3 the speed can even be adjusted in the dark.



Fig. 12

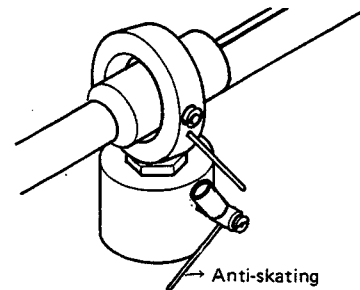

Fig. 11

Cue Control Adjustment

It will be necessary to adjust the cue control when the elevator height must be changed because of a new cartridge, etc. The adjustment is made by tightening or loosening the internal screw as shown. This adjustment will seldom be necessary in normal service conditions, only when the elevator height is changed.

Adjustment of Automechanisms

1. Auto-return Positioning (Lead-out Adjustment)

Make this adjustment when the pickup fails to return automatically when the record has been played or it returns before the end of the record.

Loosen the two screws on the feed arm as shown and adjust the distance between the trip slide and the feed arm. Decrease this distance if the pickup does not return automatically and increase it if premature auto-return is the problem. Ideally the auto-return should be activated when the stylus tip is 65mm away from the center of the record, but this varies with different records.

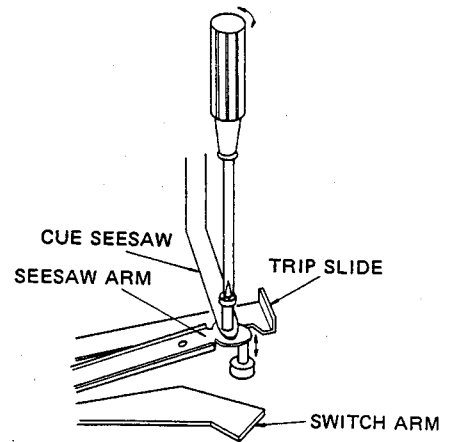

Fig. 13

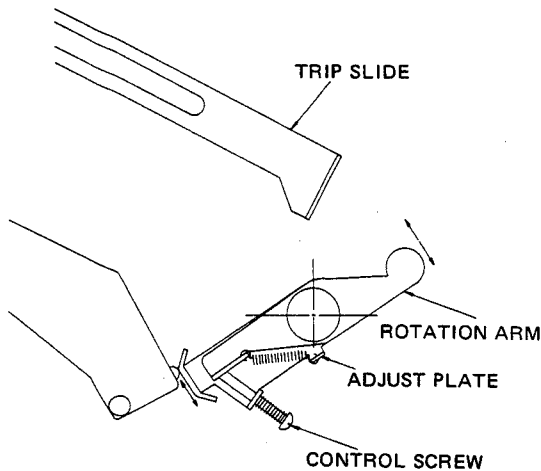

Fig. 14

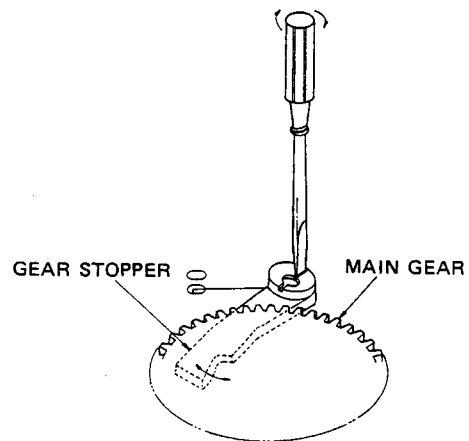

Fig. 15

2. Gear Stop Adjustment

The position of the gear stop is determined by the gear stopper as illustrated. This adjustment is required when the switch does not turn off despite normal operation of the auto-return mechanism.

- 1) Engage the turntable spindle gear with the main gear and let them make one rotation.
- 2) Place the turntable spindle gear projection as near to the main gear as possible and turn the gear stopper so that the center of the main gear notch is aligned with the projection. This gear stopper turns eccentrically. Confirm that the micro-switch is turned completely OFF in this position.

Note : In the JL-A3 the generator is built into the upper part of the motor, unlike in ordinary motors, and the pulley constitutes parts of the generator rotor. Since servicing of the pulley alone is not possible, be careful not to damage the pulley. Do not try to adjust the height of the pulley yourself. This is because the current flowing through the generator varies with the height of the pulley and, if the current becomes excessive, the generator may cease to work, motor vibrations may increase and the S/N may deteriorate.

In the event of the pulley becoming unusable the whole motor assembly will have to be serviced.

SERVICING HINTS

Problems	Causes	Defective parts and remedies
1. Turntable does not rotate with power switched on.	<ol style="list-style-type: none"> 1. No current flowing to motor 2. Defective motor 3. Faulty printed circuit 4. Belt and pulley disengaged or not properly engaged 	<ul style="list-style-type: none"> • Damaged switch -- Replace • Broken power cord -- Replace • Bad connections -- Check • Motor winding faulty (when motor drive current is correct) -- Replace motor • Power transistor X305 damaged -- Replace (When other parts are defective, the motor may operate at 100V, however, it may run out of control.) • Belt not engaging with pulley -- Make them engages. • Belt slippage -- Wipe belt, pulley and turntable with alcohol.
2. The turntable speed cannot be controlled	Defective printed circuit	<ul style="list-style-type: none"> • Defective constant voltage circuit prevents control circuit from operating normally -- Check constant voltage circuit • Defective control circuit -- Check the terminal voltages of each transistor.
3. Speed of turntable varies by over 0.3% with time	Defective printed circuit	<ul style="list-style-type: none"> • Temperature compensation varistor D301 is broken -- Replace • Constant voltage circuit is defective -- Check terminal voltages
4. Vibration noise from motor can be heard with played back sound	Motor not floating correctly	<ul style="list-style-type: none"> • Motor suspension rubber bushing is broken -- Replace • Motor wires are not properly arranged -- Check
5. Rotation is uneven	<ol style="list-style-type: none"> 1. Slipping 2. Eccentricity 	<ul style="list-style-type: none"> • Belt, turntable and/or pulley, etc. are greasy -- Degrease with alcohol • Center hole of record is enlarged because of frequent playing -- Replace record • Turntable spindle is loose -- Replace
6. Record plays back with no sound	<ol style="list-style-type: none"> 1. Cartridge defective 2. Connections incorrect 3. Excessively worn stylus tip 4. Problem with amplifier 	<ul style="list-style-type: none"> • Coil in cartridge damaged -- Replace cartridge • Reconnect • Replace stylus tip • Repair amplifier

Problems	Causes	Defective parts and remedies
7. No auto-return at end of record	Turntable spindle gear and main gear do not engage	<ul style="list-style-type: none"> • Refer to the section on Auto-Return If adjustment will not get the auto-return to work, the engagement is malfunctioning or stuck with grease -- Replace or degrease
8. The pickup rises and returns before the end of the record	The trip slide functions too early	<ul style="list-style-type: none"> • widen the clearance between the feed arm and the trip slide (See the section on Auto-Return)
9. When records finish, the auto return works but the power is not switched off	<ol style="list-style-type: none"> 1. Faulty micro switch 2. The relative positions of the switch lever and feed arm are incorrect 	<ul style="list-style-type: none"> • Replace • Refer to section on Gear Stop Adjustment
10. Pickup does not track correctly	<ol style="list-style-type: none"> 1. Stylus tip 2. Stylus pressure 3. Other 	<ul style="list-style-type: none"> • Dust clogging stylus tip -- Clean with brush • Stylus tip broken -- Replace • Stylus pressure incorrect -- Adjust to correct value • Lead wire in pickup is too tight and causing friction -- Slacken it

Explanation of terms marked *

- * **Change Cycle** Cycle of pickup functions form entering the large-pitch run-out groove at the end of the record, rising and returning to the rest.
- * **Lead-out** This is part of the change cycle (above) in which the pickup lifts from the record surface after it enters the run-out groove.
- * **Shut-off** This a sequence of functions in which the pickup is returned to the arm rest at the end of the change cycle and the power is switched off at the same time.

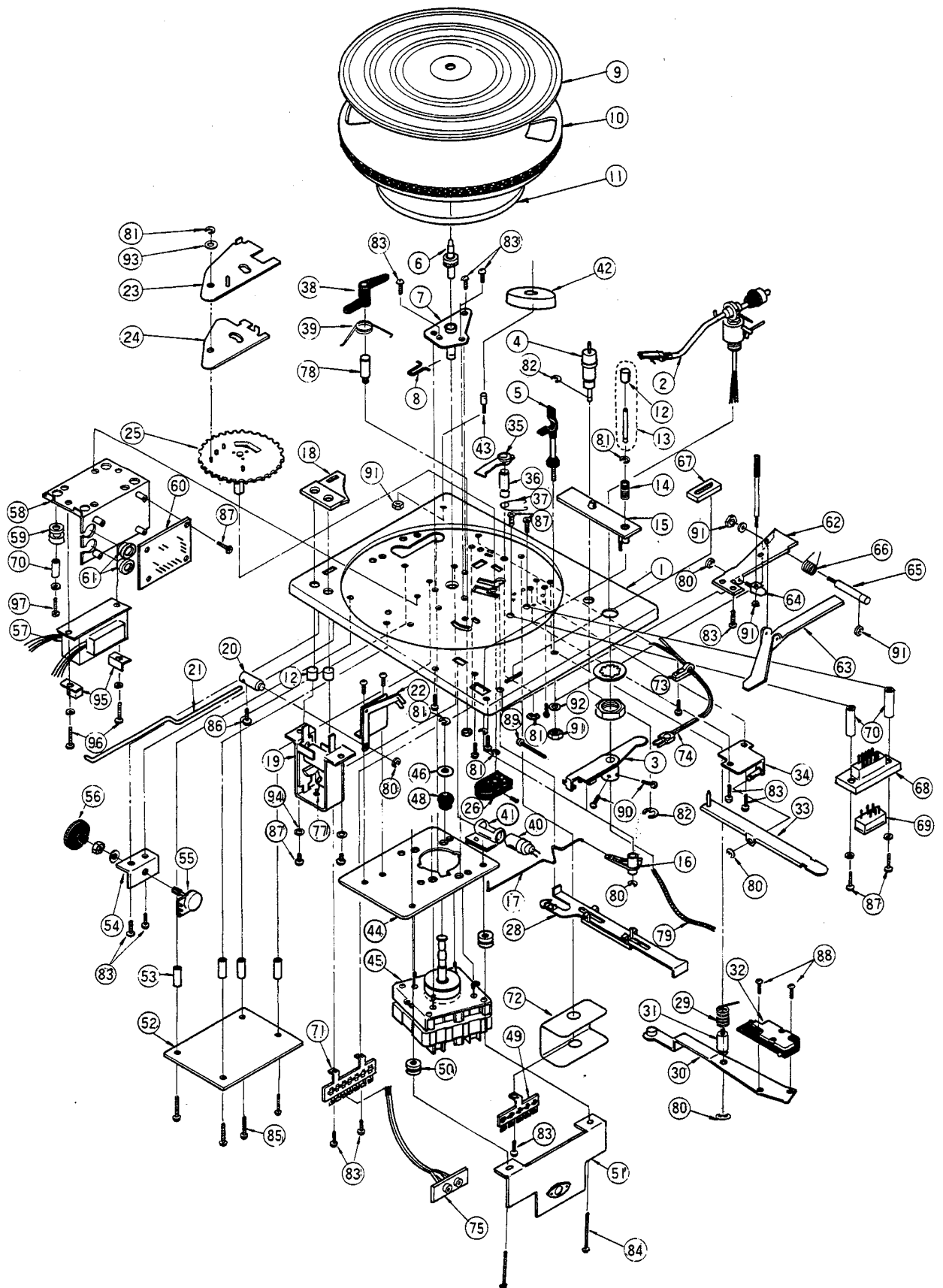

Fig. 16

NO.	PARTS NO.	PARTS NAME	REFERENCE
1	EG100771	Motor Board	with out Cartridge
2	MP138SbZ	Tone Arm Ass'y	
3	EG100585	Rotation-Arm Ass'y	
4	EG100703	Elevator Ass'y	
5	EG100574	Rest Ass'y	
6	EG100056	Turntable Shaft Ass'y	
7	EG100057	Turntable Bearing Ass'y	
8	EG100071	Stopper Pin	
9	EG100582	Turntable Sheet	
10	EG100661	Turntable	
11	EG100709	Belt	
12	G41028	Buttom	
13	EG100681	Shaft-Buttom Ass'y	
14	EG100682	Buttom Spring	
15	EG100772	Reject Cover	
16	EG100706	Push Lever	
17	EG100702	Reject Spring	
18	EG100686	Speed Control Cover	
19	EG100690	Speed Change Ass'y	
20	EG100688	Joint	
21	EG100689	Rod	
22	EG100687	Belt Shifter	
23	EG100006	Engagement	
24	EG100007	Lower Trip	
25	EG100553	Gear	
26	EG100514	Switch Lever	
27	EG100707	Tapping Plate	
28	EG100566	Trip Slide Ass'y	
29	EG100588	Switch Arm Spring	
30	EG100584	Switch Arm Ass'y	
31	EG100002	Pin	E03541-004 except Europe E03538-001 For Europe
32	E03541-004 or E03538-001	Micro Switch	
33	EG100031	Seasaw Arm Ass'y	
34	EG100545	Seasaw Base Ass'y	
35	EG100510	Gear Stop Arm	
36	EG100508	Gear Stop Shaft	
37	EG100012	Gear Stop Spring	
38	EG100014	Kick Lever	
39	EG100015	Kick Lever Spring	
40	QLN1601-004	Neon Lamp	
41	EG100716	Neom Lamp Bracket	
42	G8395	E.P Adaptor	
43	EG100505	E.P. Adaptor Holder	
44	EG100700	Motor Mounting Plate	
45	EG100701	Motor Ass'y	
46	EG100714	Adjust Washer	
47	EG100074	Washer	
48	EG100699	Rubber Bushing	
49	EG100710	Lug Strip Ass'y	
50	EG100698	Bushing	

NO.	PARTS NO.	PARTS NAME	REFERENCE
51	EG100696	Heat Shink	
52	TAD-134	Control Circuit Ass'y	
53	EG100697	Stud	
54	EG100695	Volume Holder	
55	QVF1A2B-052A	Volume	500Ω B
56	EG100694	Volume Knob	
57	E03032-14C	Power Trnasformer	
58	EG100779	Trans Bracket	
59	EG100782	Rubber Bushing	
60	TAP-233A, B	Circuit Ass'y	B . . . only Europe
61	E5629-2	Insulator Bushing	
62	EG100774	Seasaw Angle Ass'y	
63	EG100775	Cue-Seasaw	
64	EG100776	Cue-Cum	
65	EG100777	Cue Rot Ass'y	
66	EG100783	Seasaw Spring	
67	EG100773	Cue Control Ornament	
68	QMC9004-001	Voltage Select Socket	
69	QMC9005-001	Voltage Select Plug	
70	E44182-005S	Stud	
71	EG100042	Lug Strip Ass'y	
72	EG100524	Shield Cover	
73	G4084	Cord Clamp	
74	QMP1200-244	Power Cord with Plug	
	E03329-001	"	
	E03544-001	"	
	Q03062-3	"	
	E03551-002	"	
75	E47916-001	Pin Jack-Cord Ass'y	UNIVERSAL GENERAL EUROPE only SEMKO only SEV only AUSTRALIA
76	E33210-001	Signal Cord Ass'y	
77	EG100691	Spring	
78	EG100501	Reject Shaft	
79	EG100701	Shield Wire	
80	REE3000	"E" Ring	
81	REE4000	"	
82	REE8000	"	
83	SBSB3008Z	Tapping Screw	
84	SBSB3016Z	"	
85	SBSB3020Z	"	
86	SPSP3003ZS	Screw	
87	SPSP3006ZS	"	
88	SPSP3014ZS	"	
89	SPSP3016ZS	"	
90	SSS3008ZS	"	
91	NNZ3000ZS	Nut	
92	WNS3000Z	Washer	
93	Q03093-502	"	
94	WLS3000	Spring Washer	
95	E41407-001	Bracket	
96	SPSP4010ZS	Screw	
97	SPSP4020ZS	"	

PICK-UP

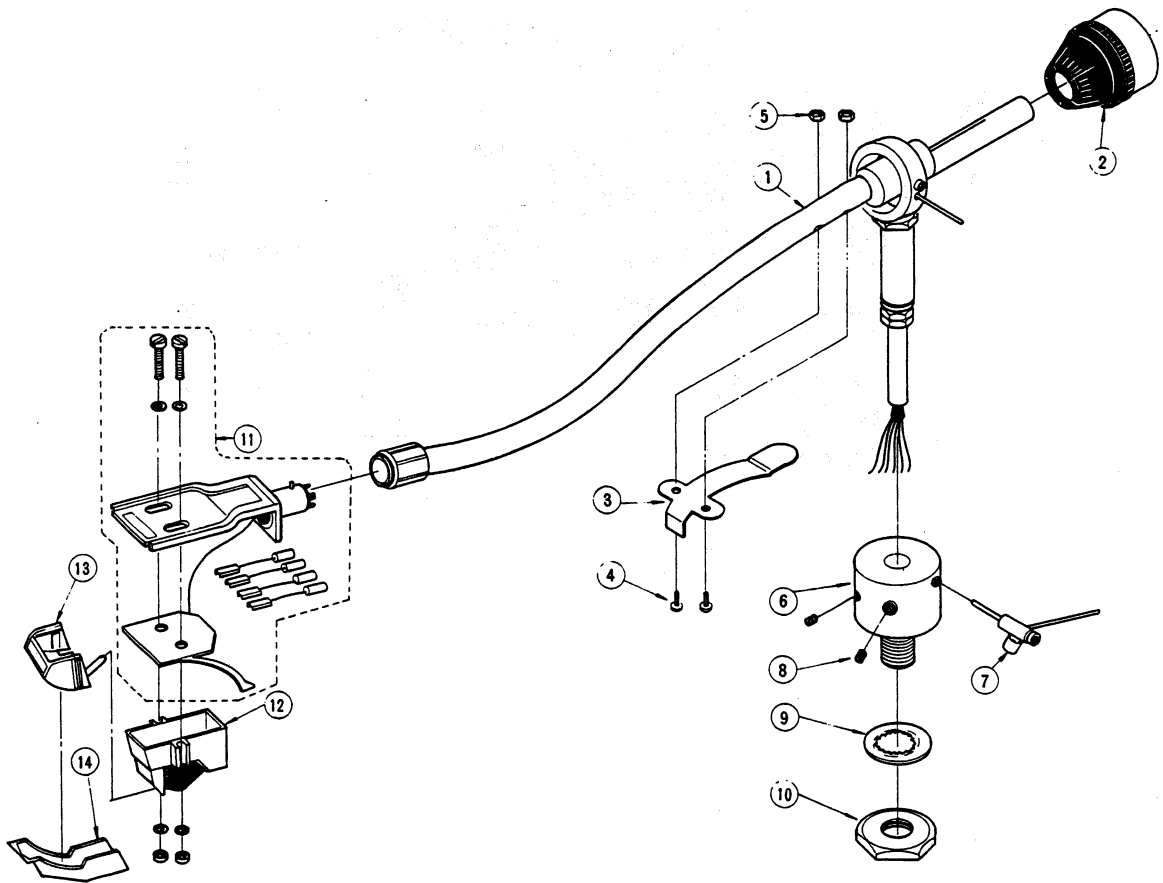

Fig. 17

NO.	PARTS NO.	PARTS NAME	REFERENCE
1	EG80252	Tone Arm Body	
2	EG81709	Main Weight Ass'y	
3	EG81695	Lift Arm	
4	SPSP2006NS	Screw	
5	NNZ2000NS	Nut	
6	EG83385	Base Ass'y	
7	EG81694	Anti Skating Ass'y	
8	YR4005MS	Set Screw	
9	EG85059	Washer	
10	EG85060	Nut	
11	EG81500I	Head Shell Ass'y	
12	MD-1016BZ	Cartridge Body	
13	DT-33S	Stylus	
14	EG1419	Protect Cover	

TAD-134

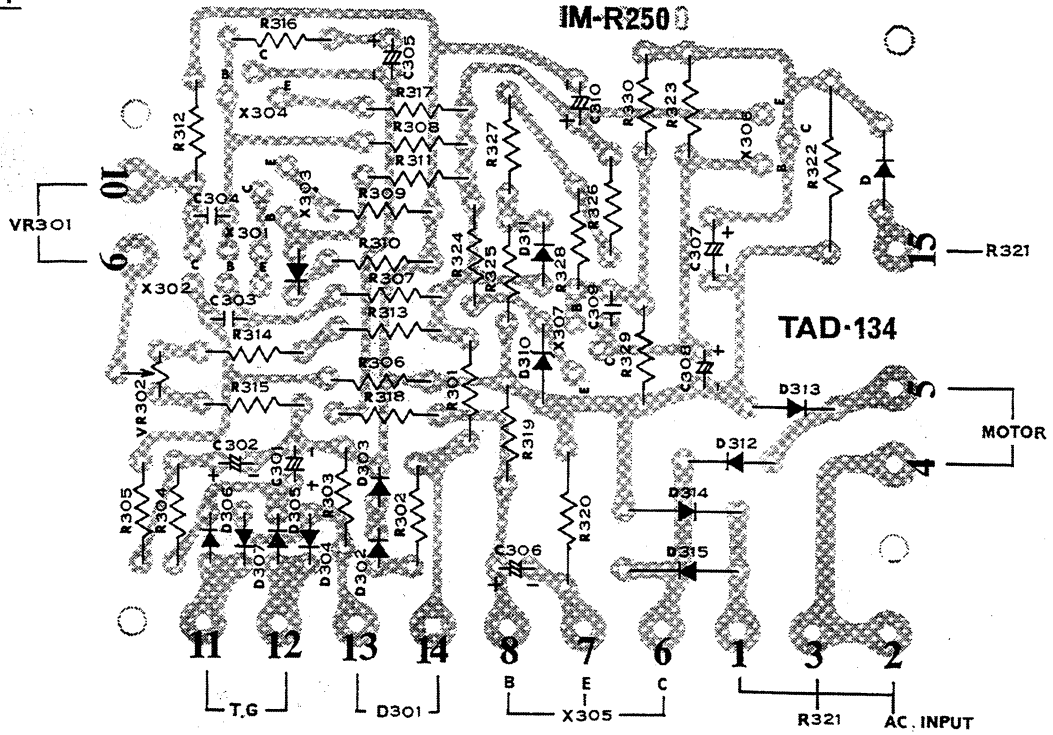

Fig. 18

NO.	PARTS NO.	PARTS NAME	REFERENCE
1	2SC923	Transistor	X301,302 (NEC)
2	2SC945	"	X303,307 (")
3	2SA733	"	X304 (")
4	2SC1161	"	X305 (")
5	2SD261	"	X306 (")
6	STV4	Varistor Diode	D301 (SANKEN)
7	VD1220	Diode	D302,303
8	1S1210	"	D304~307
9	1S1212	"	D308
10	F14C	"	D309
11	RD7A	Zener Diode	D310
12	QRD141J-102	Carbon Resistor	R302
13	" -122	"	R304,305,319
14	" -123	"	R311,315,325
15	" -152	"	R307,318
16	" -182	"	R309
17	" -222	"	R310
18	" -272	"	R310,303
19	" -392	"	R312,316,324
20	" -474	"	R330
21	" -561	"	R314,317,327
22	" -562	"	R313,323
23	" -681	"	R326
24	" -682	"	R308,328,329
25	" -822	"	R306
26	QRC122K-4R7	Comp. Resistor	R320 1/2W
27	QRG011K-222	O.M. Resistor	R322 1W
28	QVF1A2B-052A	V. Resistor	VR301
29	E03511-102	M. G. V. Resistor	VR302
30	QEW41CA-105	E. Cap	C301
31	" -335	"	C302
32	" -475	"	C305
33	" -106	"	C306
34	QFM41HK-103	Mylar Cap	C303,304,309
35	QEW41EA-336	E. Cap	C308
36	" -227	"	C310
37			
38			
39			

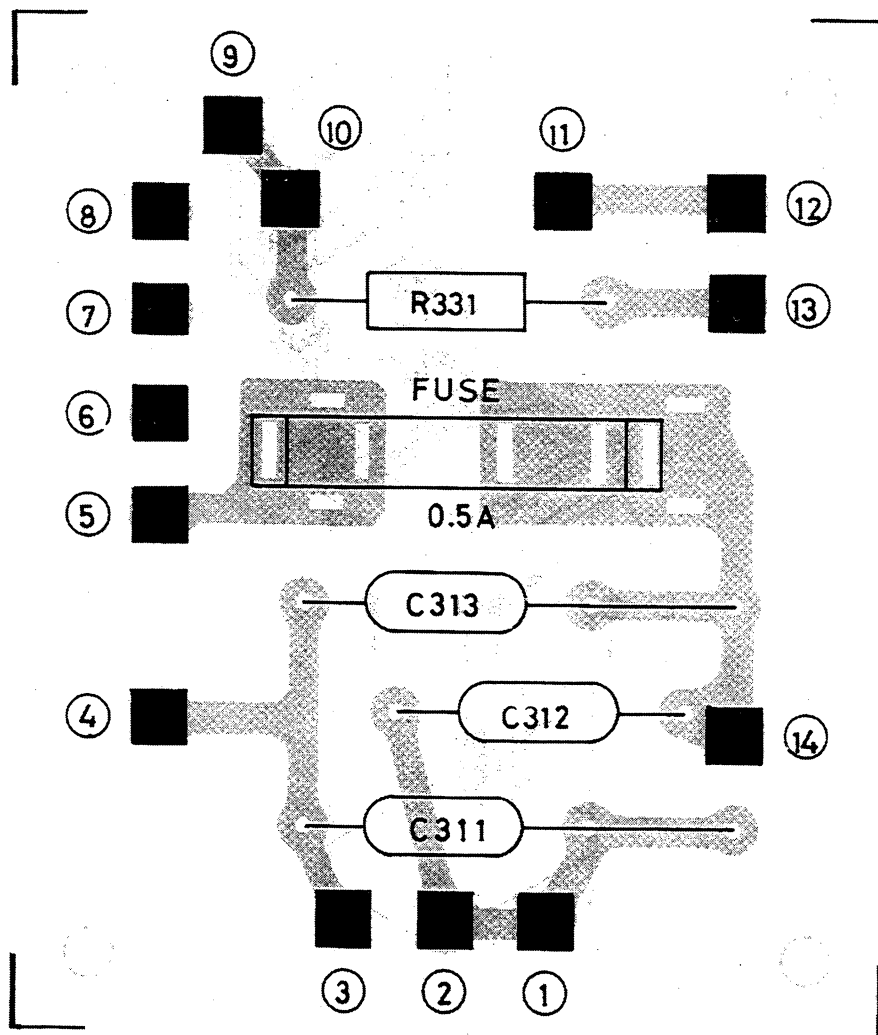

Fig. 19

NO.	PARTS NO.	PARTS NAME	REFERENCE
1	QRG021K-392	O. M. Resistor	R331
2	*QFZ9006-473	M. P. Cap	C311
	QFH53AM-473	M. M. Cap	C311
3	*QFZ9006-103	M. P. Cap	C312
	QFH53AM-103	M. M. Cap	C312
4	*QMF51A2-R50	Fuse (0.5A)	
	QMF60R1-R50	" (0.5A)	
5	*E48965-001	Contact Clip	
	E45524-001	"	
6	E43727-002	Tab	

Note * mark → For Europe

CABINET

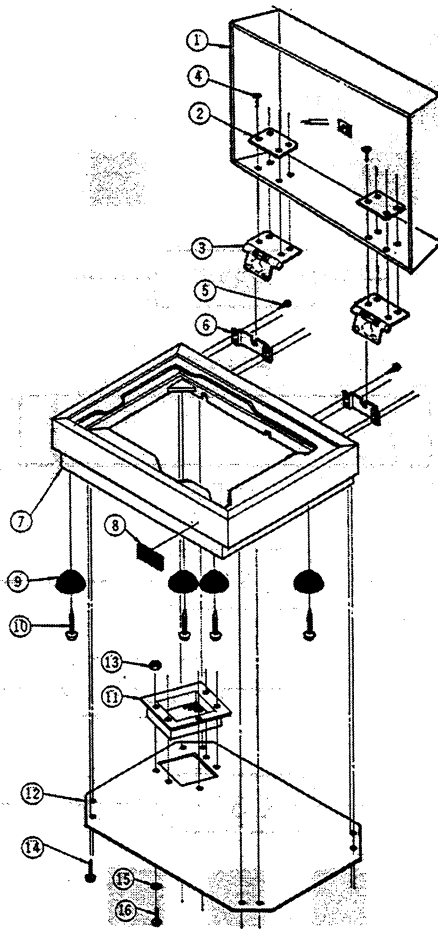

Fig. 20

NO.	PARTS NO.	PARTS NAME	REFERENCE
1	E1603-008	Cover Ass'y	
2	ED42992-001	Plate	
3	ED35375-001	Hinge Ass'y	
4	SHSP3016RS	Screw	
5	MRSP3110M	Wood Screw	
6	ED42991-001	Lock Plate	Only Wood Base
7	ED92452	Cabinet Ass'y	
8	ED43231	Mark	
9	E46927-003	Foot	
10	MRSP2716M	Wood Screw	
11	E46484-002	Protector	
12	E33549-001	Bottom Board	
13	NNZ3000ZS	Nut	
14	MRSP2710M	Wood Screw	
15	WNB3000M	Washer	
16	SPSP3010MS	Screw	

SCHEMATIC DIAGRAM

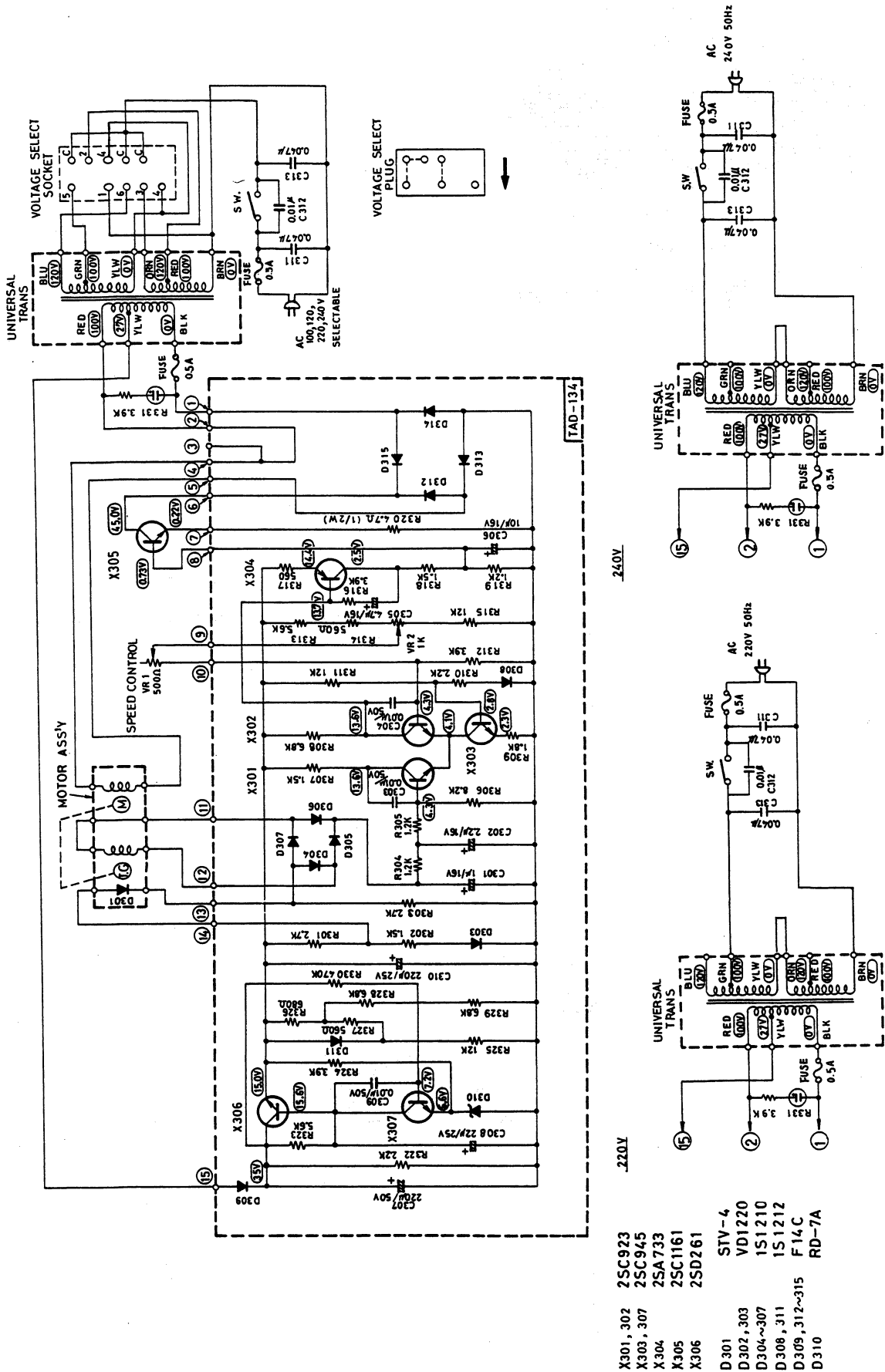
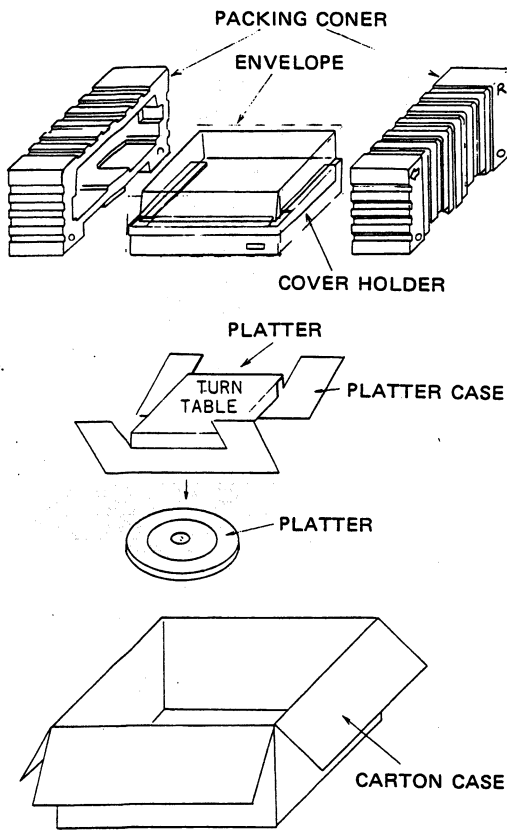

Fig. 21

FINAL PACKING ASS'Y



PARTS NO.	PARTS NAME
JL-A3J-PK	CARTON CASE
JL-A3J-NZ	PACKING MATERIALS

Fig. 22

ACCESSORYS

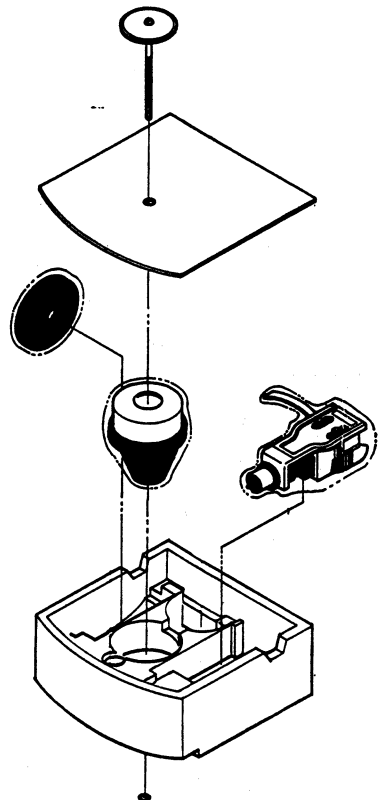

Fig. 23