

JVC

SERVICE MANUAL

MODEL
JR-S400
STEREO RECEIVER

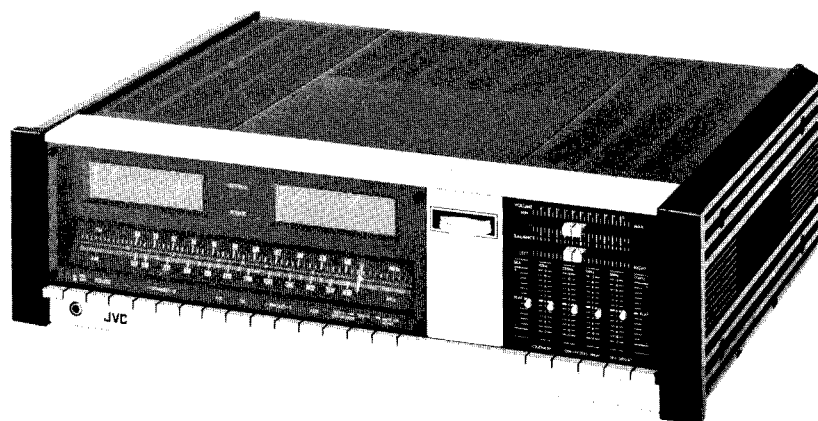

No. 2371
MAR. 1976

Contents

	Page
1. Specifications	2
2. Level Diagram	3
3. Removal of Top Cover, Bottom Plate and Front Panel	4
4. Main Parts Locations	6
5. Exploded View and Parts List	
5-(1) Front Panel	7
5-(2) Rear Panel	8
6. Dial Stringing Procedure	9
7. FM/AM Tuner Alignment Procedures	
7-(1) FM Section	10
7-(2) AM Section	12
8. Power Amplifier Adjustment Procedures	
8-(1) Center Voltage	13
8-(2) Idling Current	13
8-(3) Power Meter	14
9. Circuit Board Ass'y Part Locations and Parts List	
9-(1) TPS-48 AC Block C.B. Ass'y	15
9-(2) TPS-49C Fuse C.B. Ass'y	15
9-(3) TPS-50B Meter Lamp C.B. Ass'y	16
9-(4) TPS-68A Stabilizer C.B. Ass'y	16
9-(5) TAP-258 Power Amp. C.B. Ass'y	17
9-(6) TAP-259 Power Amp. C.B. Ass'y	19
9-(7) TAP-260 Power Supply C.B. Ass'y	22
9-(8) TAC-402B S.E.A. (Sound Effect Amp.) Control C.B. Ass'y	24
9-(9) TAC-406 S.E.A. (Sound Effect Amp.) Amp. C.B. Ass'y	26
9-(10) TAC-408B Speaker C.B. Ass'y	29
9-(11) TAC-414 Selector C.B. Ass'y	30
9-(12) TFM-910GUA2 FM/AM Tuner C.B. Ass'y	33
10. Packing Materials List	38
11. Accessories List	38
12. Transistor, I.C. and Diode Lead Identification	39
13. Parts List with Specified Numbers for Designated Areas	40
14. Schematic Diagram	41

1. Specifications

Dimensions	: 6-11/16"(H) x 22-1/16"(W) x 17"(D) (16.9cm x 56.0cm x 43.1cm)
Weight	: 37.4 lbs. (17.0kg)
Amplifier Section	
RMS Power Both channels driven	: 70 watts per channel, min. RMS at 8 ohms from 20Hz to 20kHz with no more than 0.2% total harmonic distortion.
RMS Power Both channels driven at 1kHz	: 80 watts per channel at 8 ohms 100 watts per channel at 4 ohms
Total Harmonic Distortion	: 0.3% at rated output
Damping Factor	: 50 at 8 ohms
Input Sensitivity, Impedance and Signal to Noise Ratio	: Phono : 2.5mV/50k Ω & 70dB Aux. : 220mV/60k Ω & 95dB Tape Mon. : 220mV/60k Ω & 95dB
Recording Output Level	: 150mV (Pin) 30mV/80k Ω (DIN)
Frequency Response	: 20Hz to 20kHz +0dB, -0.5dB
S.E.A. Center Frequency	: 40Hz, 250Hz, 1kHz, 5kHz & 15kHz
S.E.A. Control Range	: \pm 12dB
FM Tuner Section	
Usable Sensitivity	: 1.7 μ V IHF
Total Harmonic Distortion at 1kHz and 100% modulation	: 0.1% (Mono) 0.25% (Stereo)
Signal to Noise Ratio max., at 1000 μ V input	: 72dB (Mono) 65dB (Stereo)
Selectivity	: 80dB IHF Alternated
Capture Ratio	: 1.0dB
Image Rejection	: 90dB at 98MHz
IF Rejection	: 100dB at 98MHz
Stereo Separation	: 50dB at 1kHz 35dB at 10kHz
AM Section	
Usable Sensitivity	: 30 μ V, 300 μ V/m
Selectivity	: 30dB
Image Rejection	: 45dB
IF Rejection	: 50dB
Signal to Noise Ratio	: 55dB

Subject to change without notice.

2. Level Diagram

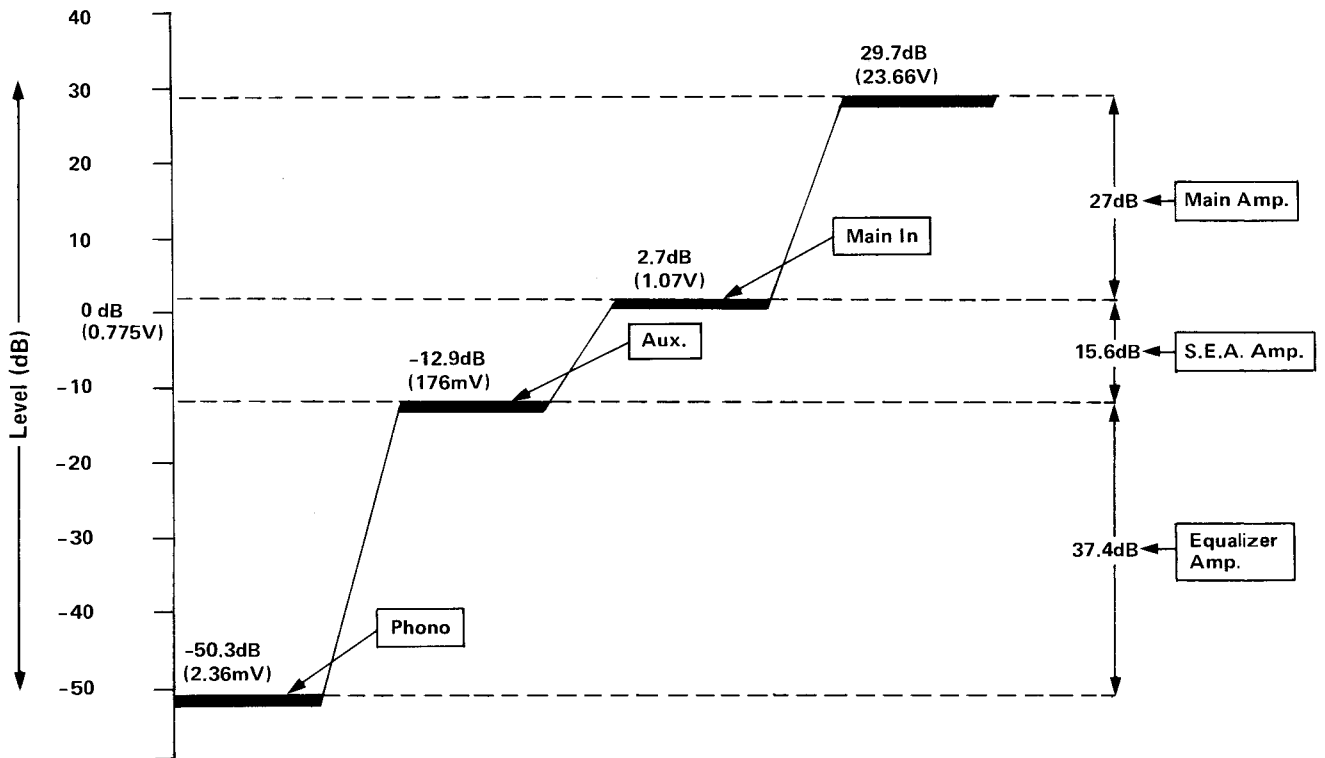
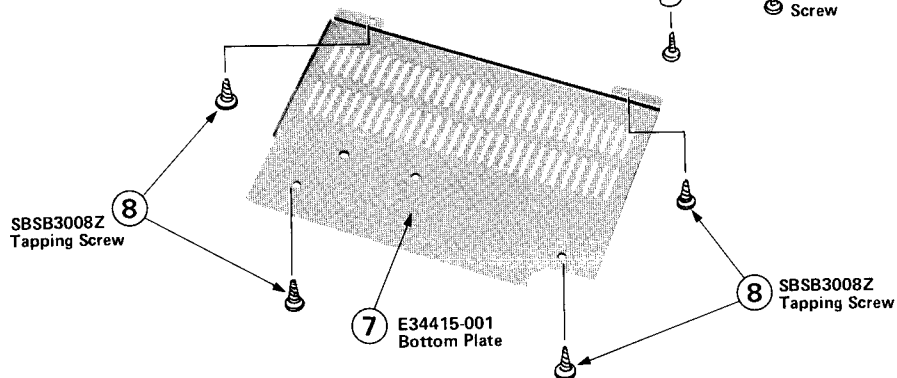
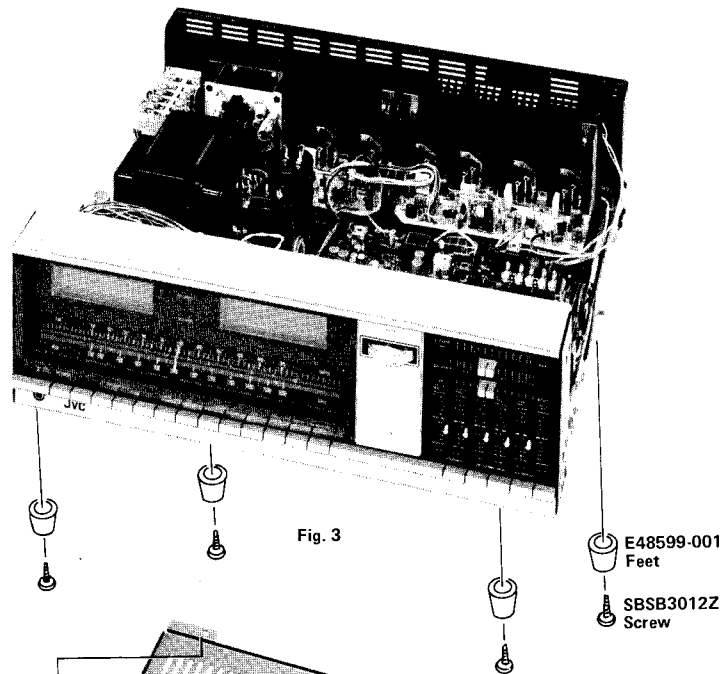
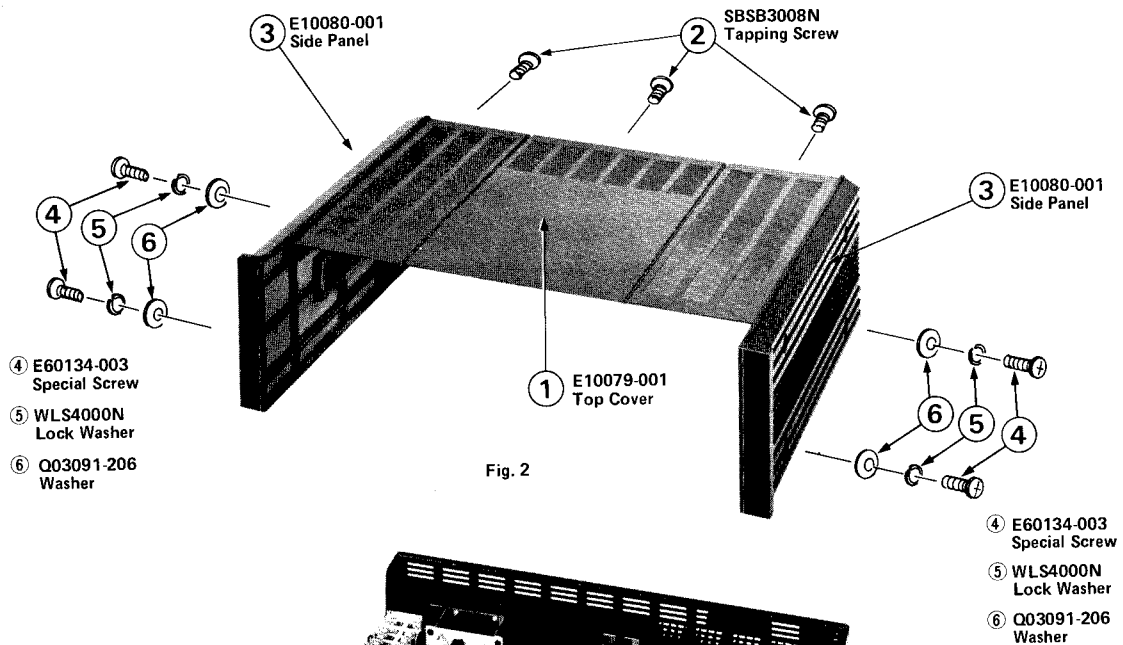

Fig. 1

3. Removal of Top Cover, Bottom Plate and Front Panel

Procedure and Part Numbers (Top Cover and Bottom Plate)

1. Remove 4 screws (Item No. 4) through the both sides of the cover and 3 screws (Item No. 2) from the back of the top cover. See Fig. 2.
2. Remove the top cover (Item No. 1).
3. Remove 4 screws (Item No. 8) from bottom plate (Item No. 7) and remove the bottom plate from the chassis. See Fig. 4.



Procedure and Part Numbers (Front Panel)

1. Remove the top cover, item no. ①. Refer to the removal of top cover on page 4.
2. Remove the dial pointer carefully according to the steps below:
 - a. Slide the dial pointer to center position of the dial rail.
 - b. Remove the dial cord from the dial pointer. Do not pull the dial cord strong.
 - c. Remove the dial pointer from the dial rail carefully.

Note: Refer to Fig. 11 of the dial stringing procedure on page 9 when replace the dial pointer onto the dial rail.

3. Remove 2 screws, item no. ② located on the bottom of the front panel.
4. Remove 8 screws, item no. ③ located on the both sides of the front panel.
5. Remove the female plugs from TAC-414 Selector C.B. Ass'y.

Note: Refer to 9-(10) TAC-414 Selector C.B. Ass'y on page 30 when reconnect the female plugs to proper positions.

In case of removing the window screen

Remove 4 hexagonal screws, item no. ③ located on the window screen. Refer to fig. 9 on page 7.

WARNING: Use a 3/32" hexagonal wrench to tighten the screws.

Do not screw in excessively hard when replacing the window screen.

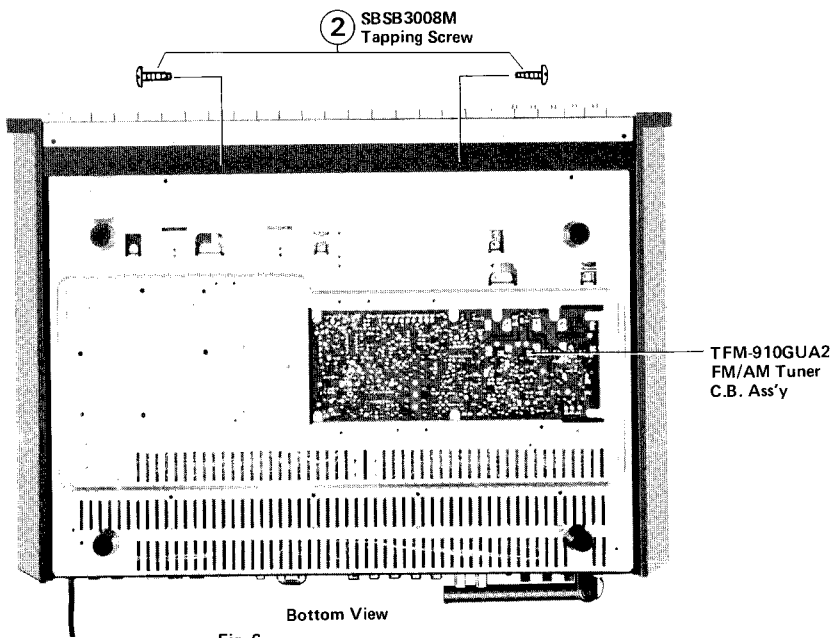
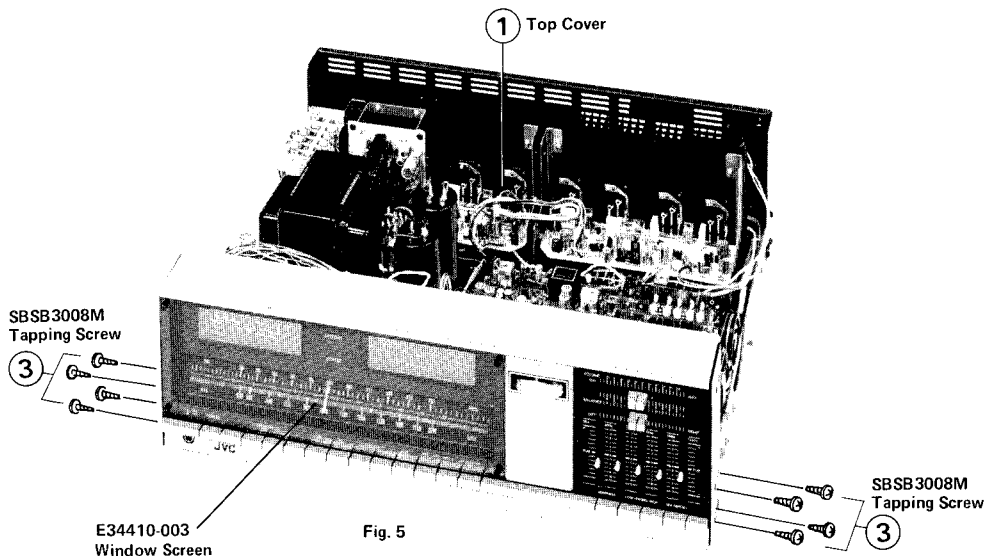
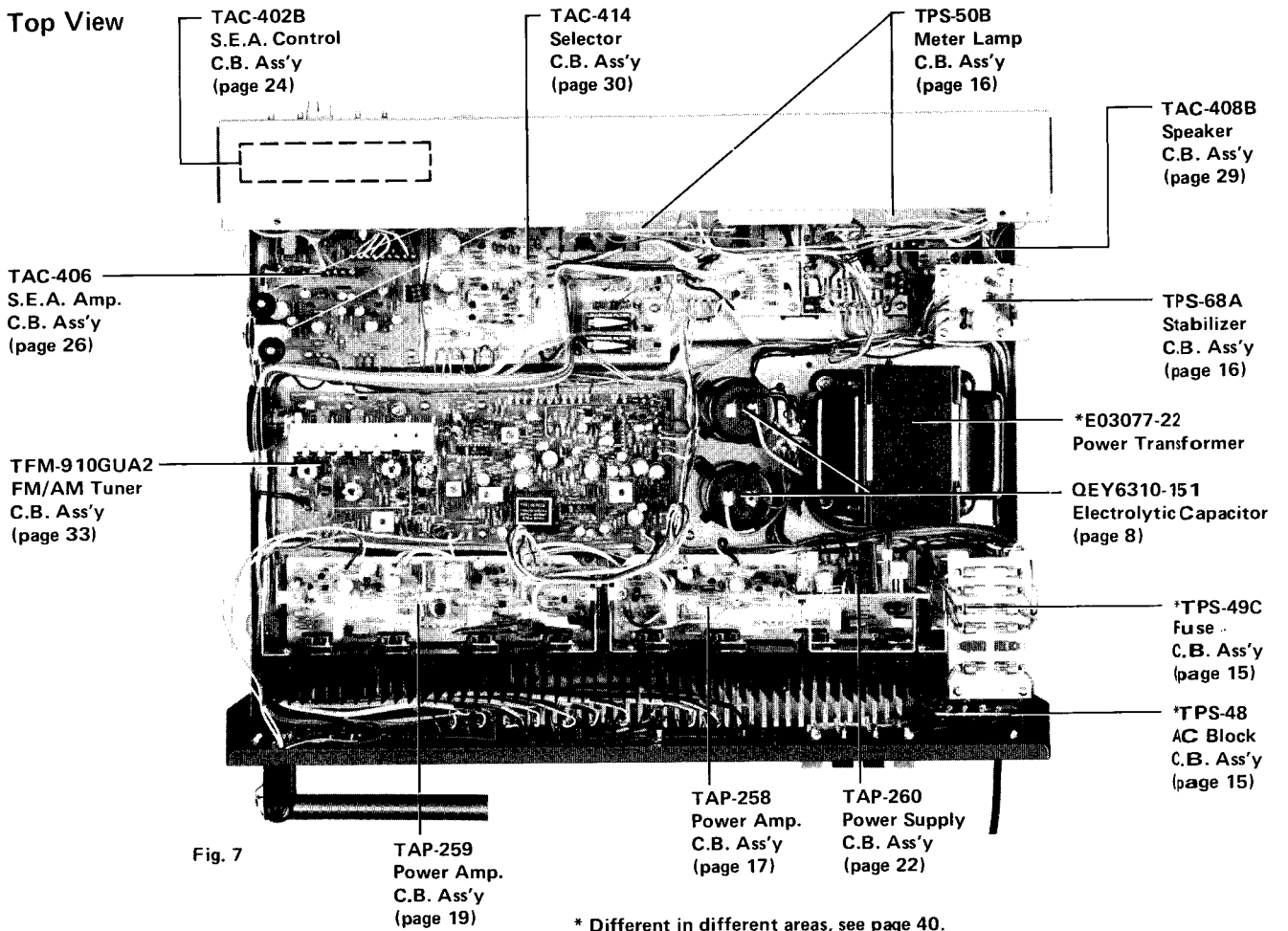

Fig. 6

4. Main Parts Locations

Top View



Bottom View

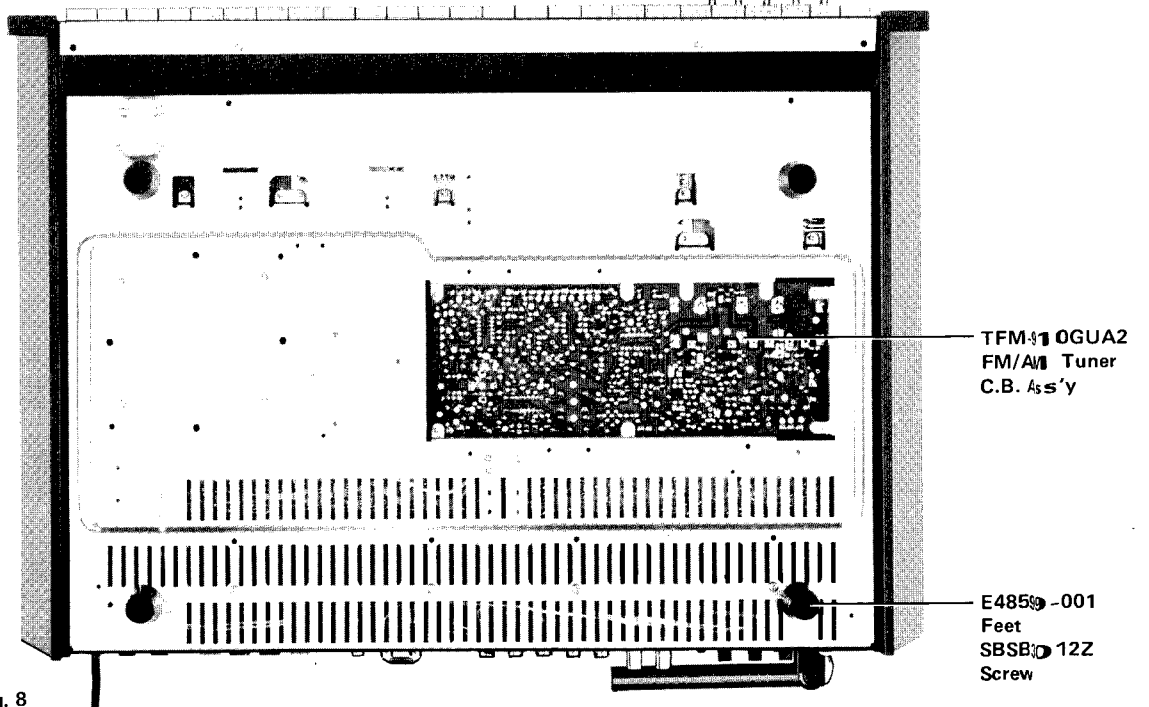

5. Exploded View and Parts List

5-(1) Front Panel

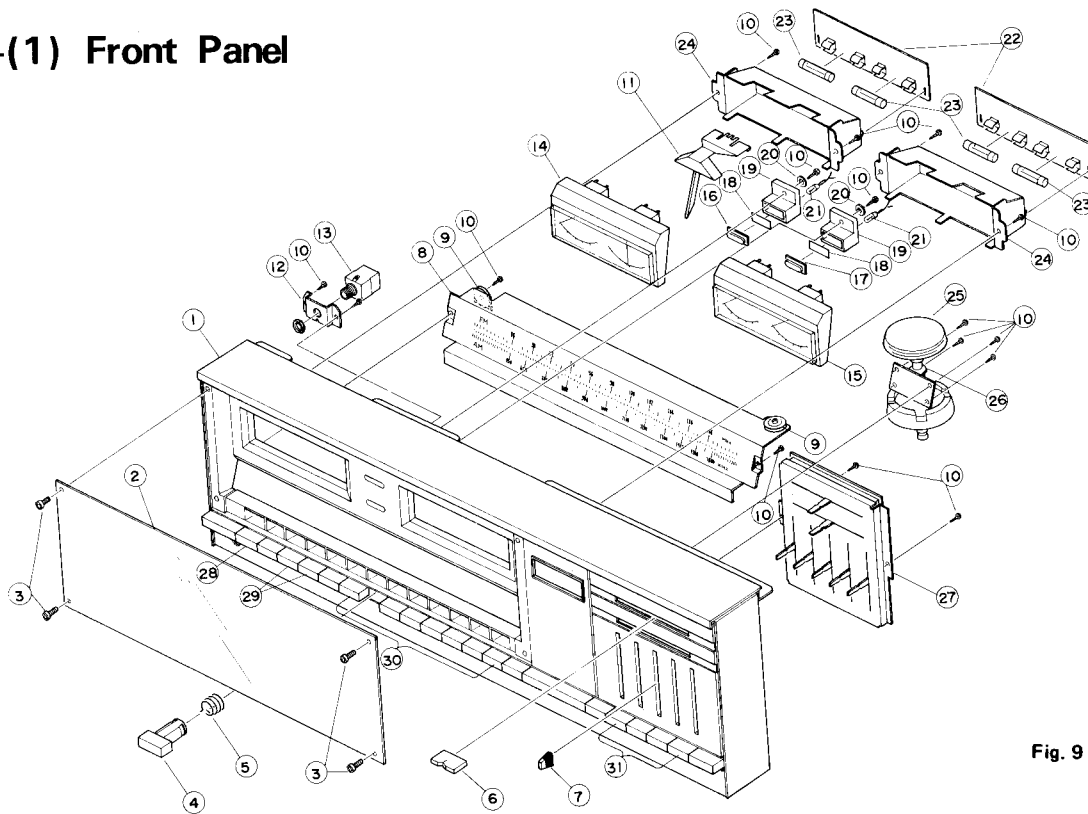

Fig. 9

Parts List

Item No.	Part Number	Description
1	E10077-002	Front Panel Ass'y
2	E34410-003	Window Screen
3	E60919-001	Hexagonal Bolt
4	E60859-001	Pushbutton
5	E47794-002	Spring
6	E60880-002	Slide Knob (Volume and Balance)
7	E60879-001	Slide Knob (S.E.A. Control)
8	E22001-001	Dial Scale
9	E45017-001	Roller
10	SBSB3010Z	Tapping Screw
11	E34422-002	Dial Pointer
12	E60926-001	V-Bracket (Headphone)
13	QMS6301-001	Headphone Jack Ass'y
14	E03680-003	Tuning Meter
15	E03680-004	Power Meter
16	E60873-001	Stereo Indicator
17	E60873-003	Power Indicator
18	E46855-043	Color Screen
19	E60874-001	Reflector
20	Q03091-105	Washer
21	QLP3104-106	Pilot Lamp (Meter)
22	TPS-50B	Lamp C.B. Ass'y (See page 16)
23	QLP4101-006	Pilot Lamp (Fuse type)
24	E34417-002	Meter Holder
25	E60869-001	Tuning Knob
26	E34420-001	Tuning Shaft Ass'y (with Tuning Knob)
27	TAC-402B	S.E.A. Control C.B. Ass'y (See page 24)
*28	QSU1135-001	Push Switch Ass'y (Power)
29	QSP0229-003	Push Switch Ass'y with TAC-408B
30	QSP0289-106	Push Switch Ass'y with TAC-414
31	QSP0249-103	Push Switch Ass'y with TAC-406

* Different in different areas, see page 40.

5-(2) Rear Panel

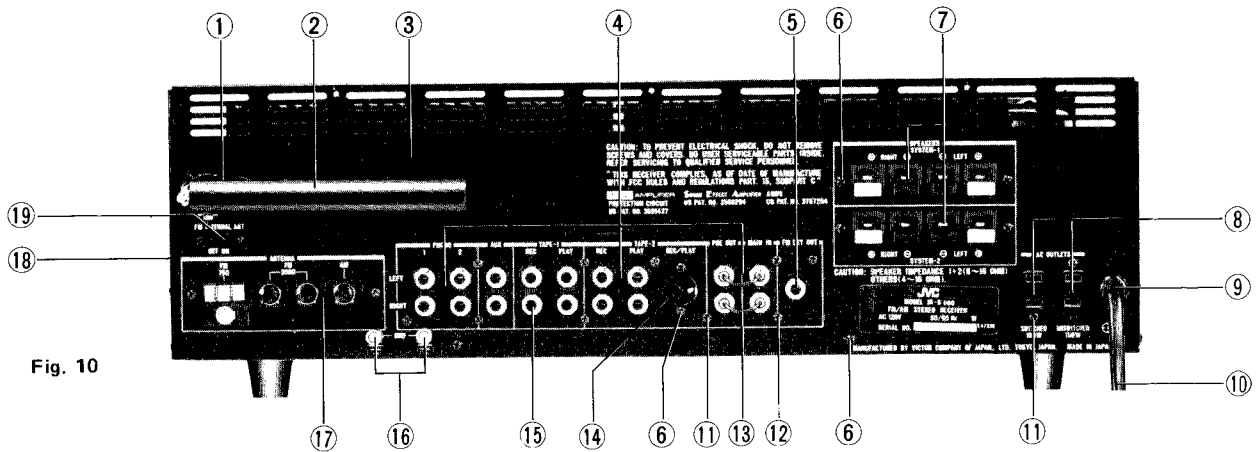

Fig. 10

Parts List

Item No.	Part Number	Description
1	E49695-002	Bar Antenna Bracket
2	E03037-31UD	Bar Antenna Coil
3	E22002-001	Rear Panel
4	E03591-41C	Pin Jack Ass'y
5	E03591-10	"
6	SBSB3008M	Tapping Screw
7	E03572-008	Speaker Terminal Board Ass'y
* 8	QMC0437-001	AC Socket (Assembled with TPS-48)
* 9	QHS3876-162	Cord Stopper
* 10	QMP1600-244	Power Cord
11	SPSP3008MS	Screw
12	SPSD3008MS	Self Tapping Screw
13	E60111-002	Short Pin Plug
14	QMC0589-005	DIN Jack
15	E03591-61C	Pin Jack Ass'y
16	E61143-001	GND Terminal Ass'y
17	E03629-001	Antenna Terminal Board Ass'y
18	SPSP2006M	Screw
19	QSS0021-002UA	Internal Antenna Switch

Capacitors

Item No.	Part Number	Rating	Description
CO05	QEY6310-151	10,000 μ F 63V	Electrolytic
CO06	QEY6310-151	" "	"
CO16	QCF11HP-103	0.01 μ F	Ceramic
CO17	QCF11HP-103	" "	"
C105	QCF11HP-103	" "	"

Resistors

Item No.	Part Number	Rating	Description
R011	QRD141J-394	390k Ω 1/4W	Carbon
R012	QRD141J-394	" "	"
R013	QRD141J-124	120k Ω "	"
R014	QRD141J-124	" "	"

Others

Item No.	Part Number	Description
1	E42803-004	Passed Mark
2	E64216-002	Caution Tag

*Different in different areas, see page 40.

6. Dial Stringing Procedure

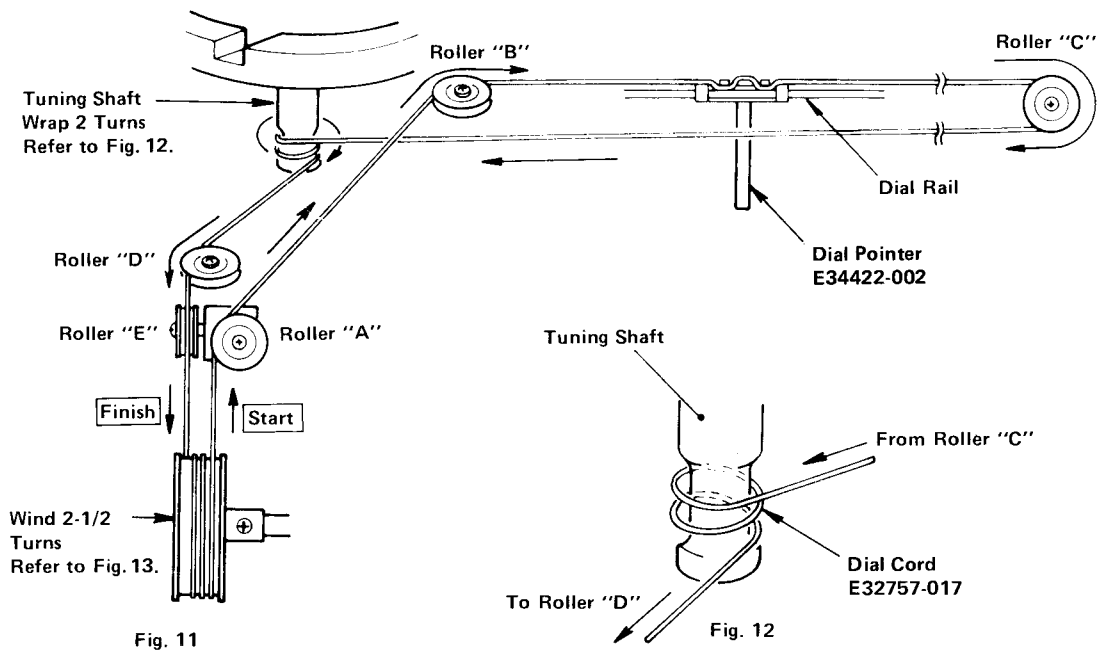

- (1) Remove dial pointer and old cord.
- (2) Tie end of new dial cord to one end of dial spring of bottom right eye inside dial drum. See fig. 13.
- (3) Rotate the tuning capacitor dial drum to its maximum counterclockwise.
- (4) Run the dial cord through the slot in the rim of the dial drum. See fig. 11.
- (5) Guide dial cord around rollers "A" and "B", and over and around roller "C". Keep the dial cord taut during this procedure.
- (6) Pull dial cord taut and wrap 2 turns around tuning shaft. See fig. 12.
- (7) Guide dial cord around rollers "D" and "E".
- (8) Guide dial cord under the dial drum and wind 2-1/2 turns clockwise. See fig. 13.
- (9) Turn the tuning shaft to rotate the dial drum fully counterclockwise and fully clockwise to distribute the tensioning along the dial cord.
- (10) Place the dial cord over and under the tabs on the rear of the dial pointer (see detail on fig. 11) and place the pointer on the top of the dial panel rail.
- (11) Turn the tuning shaft clockwise, slide the dial pointer to zero (0) calibration marker on the logging scale while holding tuning shaft fully clockwise. Cement the dial pointer to dial cord to prevent slippage. Allow cement to dry thoroughly.
- (12) Check dial calibration. Refer to FM/AM Alignment Procedure on page 10.
- (13) Replace top cover.

7. FM/AM Tuner Alignment Procedures

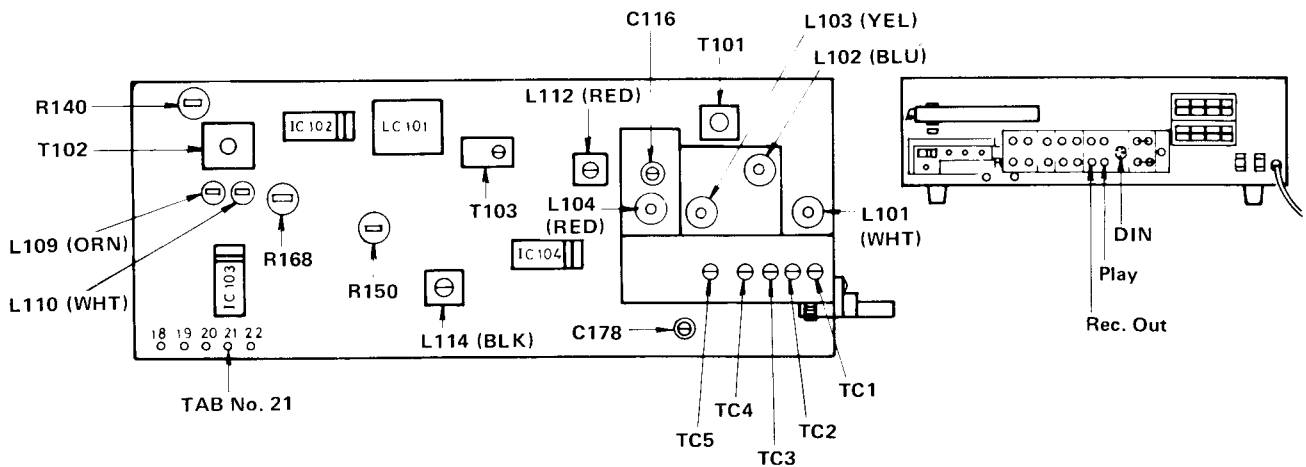

Fig. 14

7-(1) FM Section

Discriminator, Center Meter & Distortion

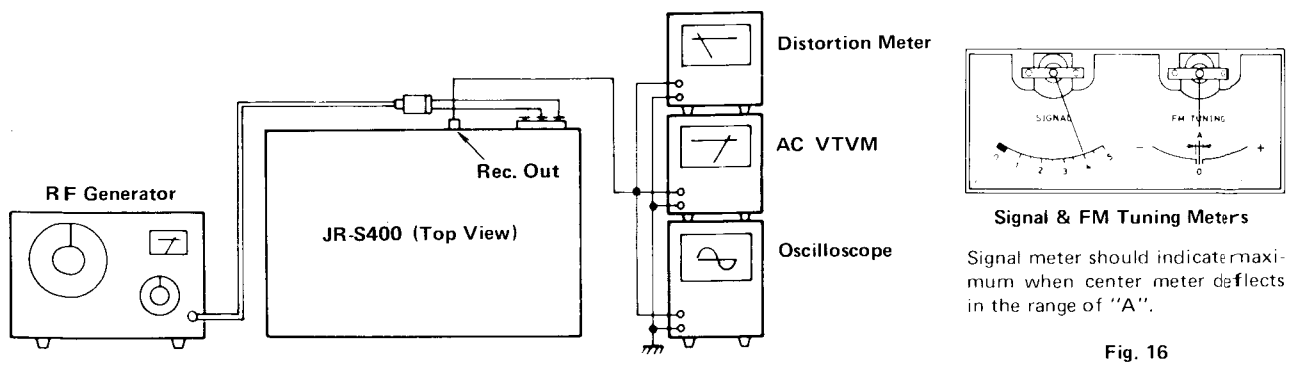

Fig. 15

Fig. 16

1. Connect an RF generator, 1kHz modulation and 75kHz deviation, to the antenna terminals on the rear panel through a dummy antenna.
2. Connect an oscilloscope, distortion meter and VTVM to the Rec. Out on the rear panel. See fig. 15.
3. Tune to a frequency where there is no broadcasting.
4. Adjust the bottom core of T102 so that the center meter indicates "0" (zero).
5. Set the RF generator to 98MHz.
6. Set the dial pointer to 98MHz.
7. Adjust the top core of T102 so that the distortion is minimized at a value less than 0.4%.

Tracking and Sensitivity

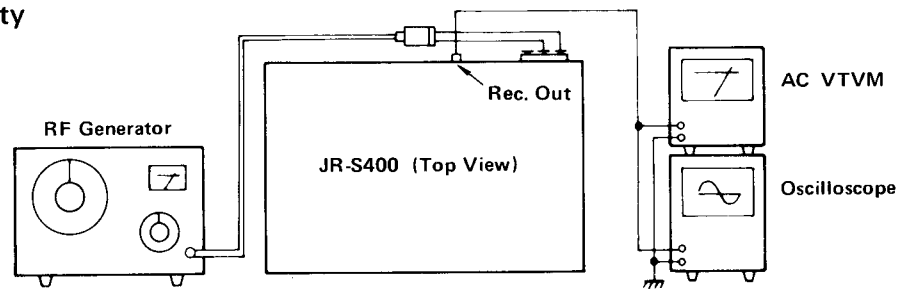

Fig. 17

Low Frequency

1. Connect an RF generator to the antenna terminals on the rear panel through a dummy antenna.
2. Set the RF generator to 88MHz, a modulation of 1kHz and a deviation of 75kHz, to provide an input of $2\mu\text{V}$.
3. Connect a VTVM and an oscilloscope to the Rec. Out on the rear panel.
4. Set the dial pointer to 88MHz.
5. Adjust five coils L104, L103, L102, L101 and T101 (top and bottom cores).

High Frequency

6. Set the RF generator to 108MHz, a modulation of 1kHz and a deviation of 75kHz to provide an input of $2\mu\text{V}$.
7. Set the dial pointer to 108MHz.
8. Set the FM trimmers C114, TC5, TC3 and TC1 in the tuning gang to maximize the output.
9. Repeat these high and low frequency adjustments alternately until maximum sensitivity is obtained.

Note: After completion of this procedure, make sure that the center meter indicates proper position. Repeat steps 4 through 7 of the center meter adjustment, if it is not indicated properly. See fig. 16.

Multiplex & Separation

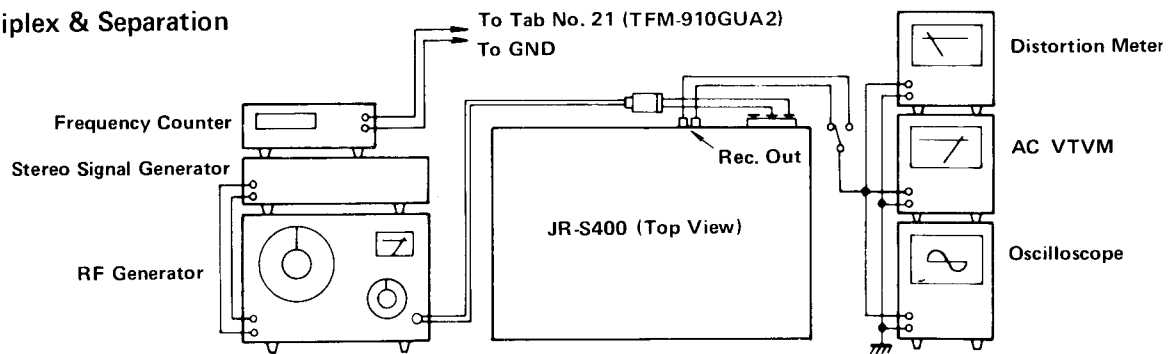

Fig. 18

Multiplex

1. Set the stereo signal generator as follows: Modulation frequency 1kHz, Deviation pilot 7.5kHz, Main and Sub. 67.5kHz. Connect its output to an RF generator.
2. Connect an RF generator to the antenna terminals through a dummy antenna.
3. Connect a VTVM, an oscilloscope and a distortion meter to the Rec. Out on the rear panel.
4. Set the RF generator to 98MHz and an output of 1mV.
5. Set the dial pointer to 98MHz.
6. Connect a frequency counter to Tab No. 21.
7. Switch the pilot signal of stereo modulator off.
8. Adjust R168 so that the frequency counter indicates 19kHz ($\pm 0.01\text{kHz}$).

Stereo Separation

9. Switch the selector of the stereo modulator to left channel modulation.
10. Adjust VR401 located on TAC-414 (Selector C.B. Ass'y) so that the output of the right channel is minimized.
11. Switch the selector of the modulator to right channel modulation.
12. Adjust VR401 located on TAC-414 so that the output of the left channel is minimized.
13. Set VR401 to average, if the separations of right and left channels are different.

Note: Keep the muting pushbutton out during this adjustment procedure of stereo separation.

Muting Level

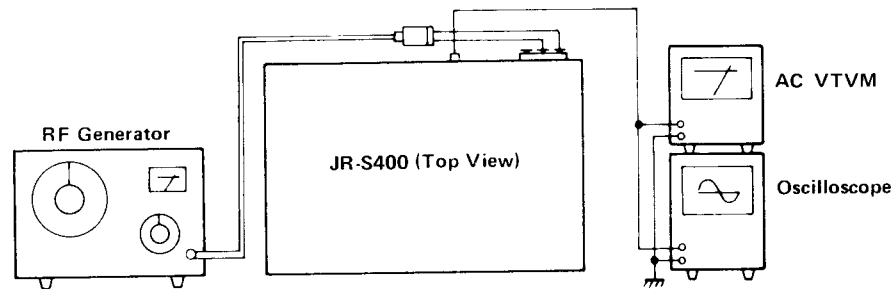

Fig. 19

1. Connect a VTVM and an oscilloscope to the Rec. Out on the rear panel.
2. Set the RF generator to 98MHz, a modulation of 1kHz and a deviation of 75kHz, to provide an input of $10\mu\text{V}$.
3. Turn R150 clockwise and remember the point at which the muting ceases operating.
4. Turn R150 counterclockwise slightly so that the output level drops by 1dB.
5. Attenuate the output of the RF generator to 2dB from $10\mu\text{V}$ of step 2 and check that the muting is still operating.

7-(2) AM Section

Tracking and Sensitivity

Low Frequency

1. Connect an RF generator to the antenna terminals on the rear panel, and set this to 600kHz with 30% modulation at 400Hz.
2. Connect an AC VTVM and an oscilloscope to Rec. Out on the rear panel.
3. Set the dial pointer to 600kHz.
4. Adjust the osc. transformer L112 and the ferrite bar antenna to maximize the output signal.

High Frequency

5. Set the RF generator to 1,400kHz with 30% modulation at 400Hz.
6. Set the dial pointer to 1,400kHz.
7. Adjust the trimmers TC4 and TC2 in the AM tuning gang so that the output signal is maximized.
8. Repeat these high and low frequency adjustments alternately until maximum sensitivity is obtained.

8. Power Amplifier Adjustment Procedures

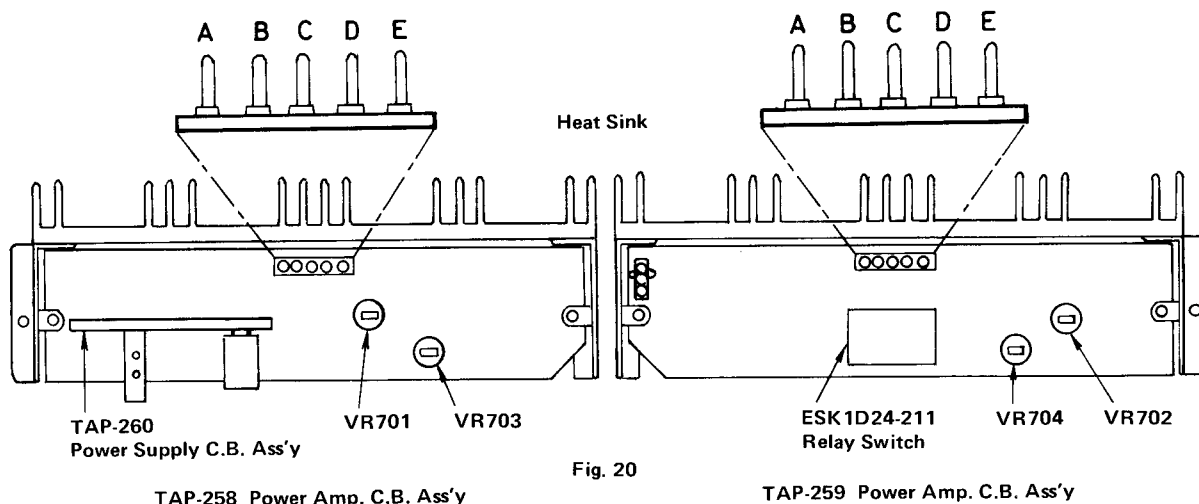

8-(1) Center Voltage

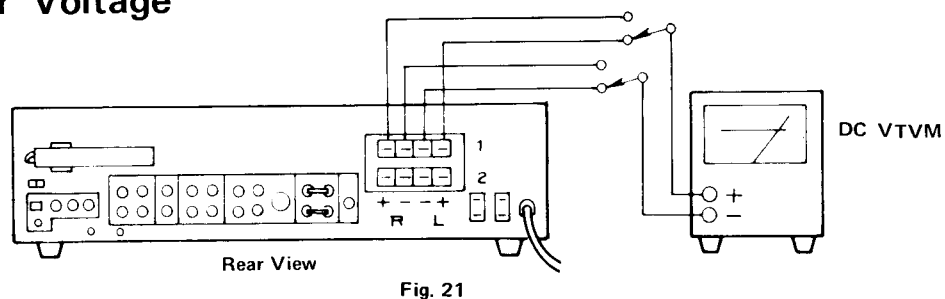

1. Set VR701 located on TAP-258 (VR702 located on TAP-259) to center position before pressing the power switch ON. Refer to fig. 20.
2. Connect a DC VTVM to left channel (right channel) speaker terminals on the rear panel. Refer to fig. 21.
3. Adjust VR701 (VR702) for DC VTVM reading of "0" Volt. Refer to fig. 20.

8-(2) Idling Current

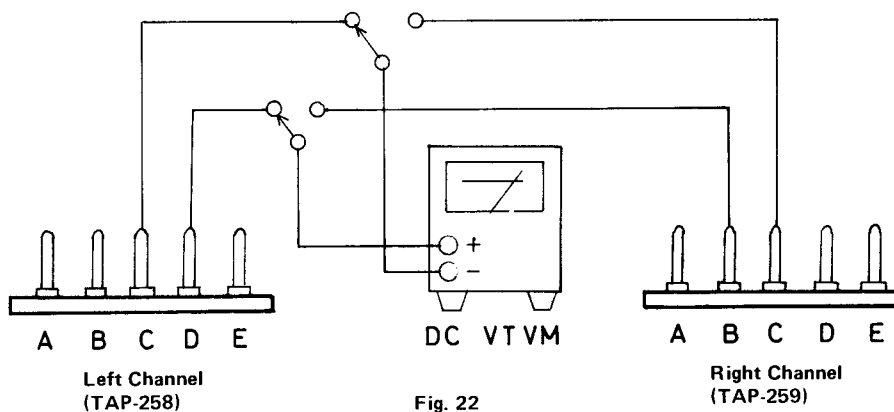

1. Turn VR703 located on TAP-258 fully counterclockwise and turn VR704 located on TAP-259 fully clockwise before pressing the power switch ON. Refer to fig. 20.
2. Connect a DC VTVM to test points "C" and "D" located on TAP-258 ("B" and "C" located on TAP-259). Refer to fig. 22.
3. Adjust VR703 located on TAP-258 (VR704 located on TAP-259) for DC VTVM reading of 10mV.

8-(3) Power Meter

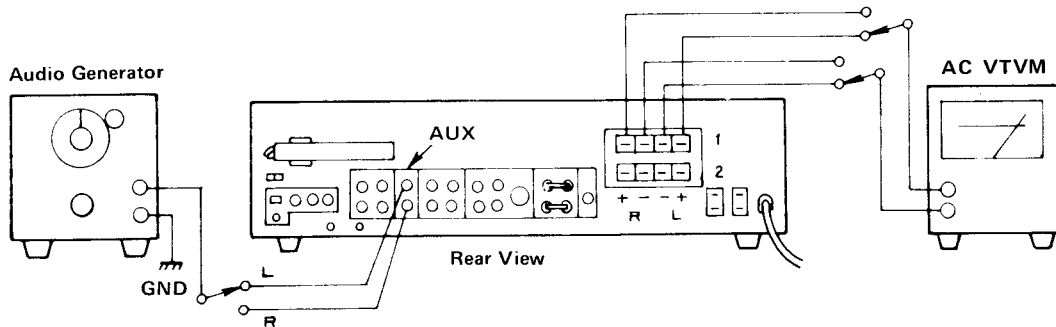
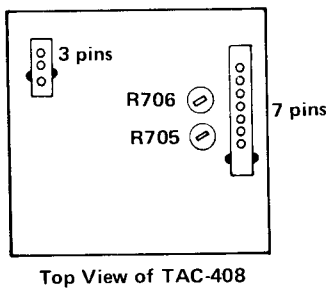
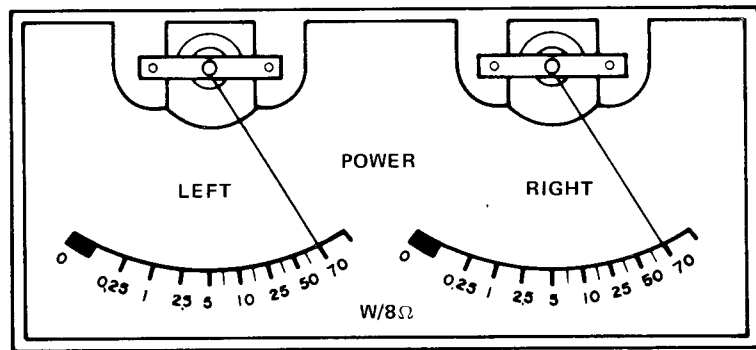

Fig. 23



Top View of TAC-408

Fig. 24



Power Meter

Fig. 25

1. Turn R706 and R706 located on TAC-408B fully clockwise. Refer to fig. 24.
2. Connect an audio generator to left channel (right channel) AUX pin-jack on the rear panel. Refer to fig. 23.
3. Set the audio generator to 1kHz and sine wave.
4. Connect a AC VTVM to left channel (right channel) speaker terminals on the rear panel. Refer to fig. 23.
5. Adjust the output of audio generator for AC VTVM reading of 23.66V.
6. Adjust R706 (R705) so that the power meter indicates 70W. Refer to fig. 25.

9. Circuit Board Ass'y Part Locations and Parts List

9-(1) TPS-48 AC Block C.B. Ass'y

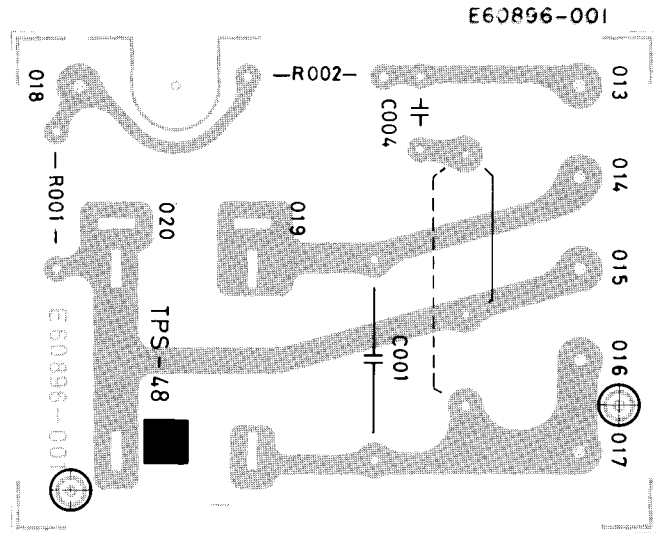

Fig. 26

Capacitors

Item No.	Part Number	Rating	Description	Maker
C001	QFH53AM-103M	0.01 μ F	AC 450V	Metalized Mylar
C002	QCZ9008-101	100pF	AC 1kV	Ceramic

Resistors

Item No.	Part Number	Rating	Description	Maker
R001	QRC121K-275E	2.7M Ω	1/2W	Composed
R002	QRC121K-105E	1M Ω	"	"

Other

Item No.	Part Number	Rating	Description	Maker
	QMC0437-001		AC Socket	

9-(2) TPS-49C Fuse C.B. Ass'y

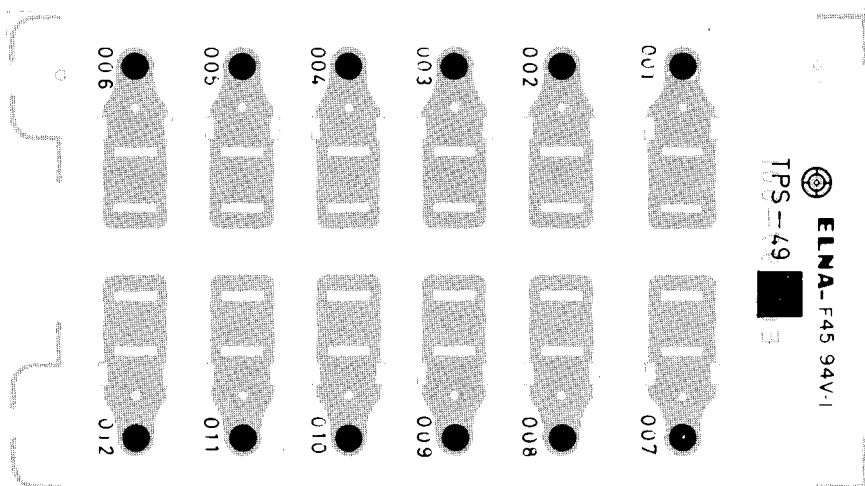

Fig. 27

Item No.	Part Number	Rating	Description	Maker
	E45524-001		Fuse Clip	

9-(3) TPS-50B Meter Lamp C.B. Ass'y

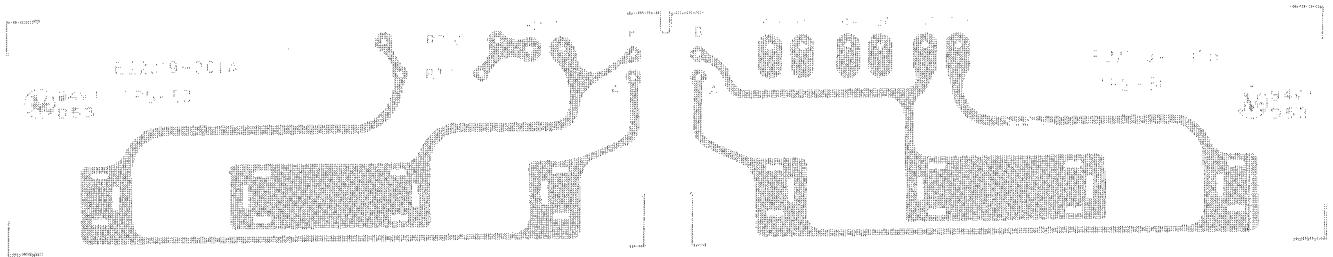

Fig. 28

Resistors

Item No.	Part Number	Rating	Description	Maker
R710	QRG016J-680	68Ω	1W	O.M.F.
R711	QRD126J-681	680Ω	1/2W	Uninflammable Carbon

Other

Item No.	Part Number	Rating	Description	Maker
	E45524-001		Fuse Clip	

9-(4) TPS-68A Stabilizer C.B. Ass'y

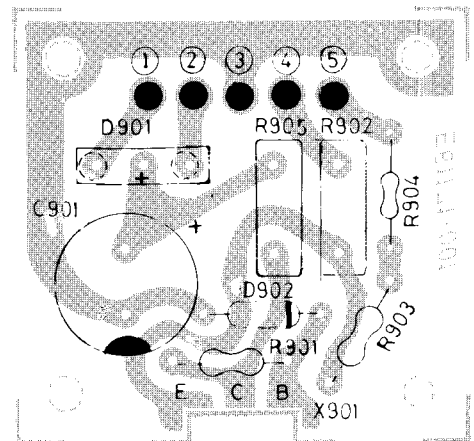

Fig. 29

Transistors

Item No.	Part Number	Rating		Description	Maker
		Pc	fT		
X901	2SD313V (D, E)	30W	8MHz	Silicon	Sanyo

Diodes

Item No.	Part Number	Rating	Description	Maker
D901	ESAB02-02C		Silicon	Kyodo Denki
D902	E0771-7		Zener	Fuji

Capacitor

Item No.	Part Number	Rating	Description
C901	QEW41EA-108	1,000μF 25V	Electrolytic

Resistors

Item No.	Part Number	Rating	Description
R901	QRD126J-221	220Ω 1/2W	Uninflammable Carbon
R902	QRM054K-R22	0.22Ω 5W	Metalized Plate
R903	QRD126J-151	150Ω 1/2W	Uninflammable Carbon
R904	QRD141J-270	270Ω 1/4W	Carbon

9-(5) TAP-258 Power Amp. C.B. Ass'y

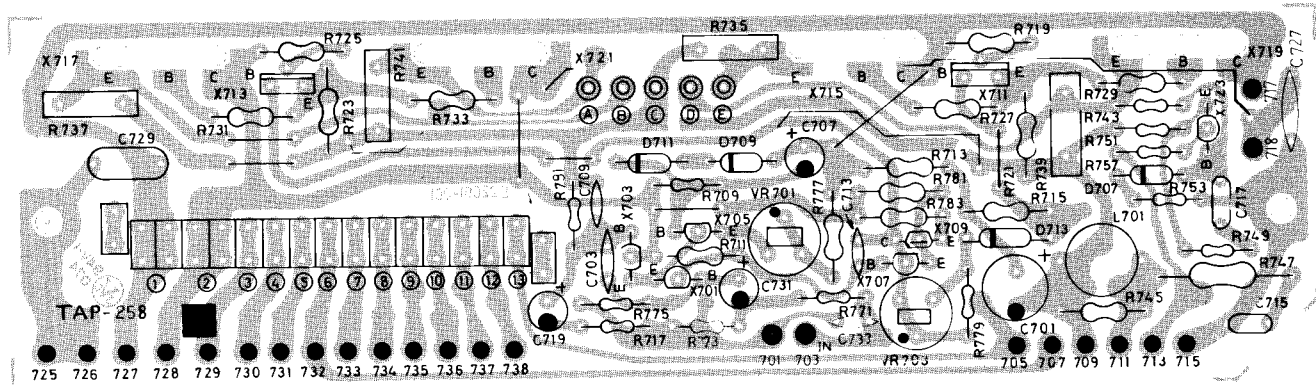

Fig. 30

Transistors

Item No.	Part Number	Rating (Pc)	(ft)	Description	Maker
X701	2SA872AV (E)	300mW	200MHz	Silicon	Hitachi
X703	2SA872AV (E)	"	"	"	"
X705	2SA872AV (E)	"	"	"	"
X707	2SC1775AV (F)	"	"	"	"
X709	2SC1628 (O, Y)	1W	40MHz	"	Toshiba
X711	2SD381 (L, M)	20W	60MHz	"	NEC
X713	2SB536 (L, M)	"	"	"	"
X715	2SC898V (B, C)	80W	15MHz	"	Hitachi
X717	2SA753V (B, C)	"	"	"	"
X719	2SC898V (B, C)	"	"	"	"
X721	2SA753V (B, C)	"	"	"	"
X723	2SC1775AV (F)	300mW	200MHz	"	"

Diodes

Item No.	Part Number	Rating	Description	Maker
D707	1S2473		Silicon	ToyoDengu
D709	1S2473		"	"
D711	1S2473		"	"
D713	SV03		Silicon Varistor	Sanken

Coil

Item No.	Part Number	Rating	Description	Maker
L701	E04059-2R7	2.7μH	Choke	

Capacitors

Item No.	Part Number	Rating	Description	Maker
C703	QCS11HJ-471	470pF 50V	Ceramic	
C707	QEW41CA-106	10μF 16V	Electrolytic	
C709	QCS11HJ-220	22pF 50V	Ceramic	
C711	QEW41HA-476	47μF "	Electrolytic	
C713	QCS12HJ-330	33pF "	Ceramic	
C715	QFM41HK-473	0.047μF "	Mylar	
C717	QFM41HK-104	0.1μF "	"	
C719	QEW41CA-226	22μF 16V	Electrolytic	
C727	QCF12HP-103	0.01μF 50V	Ceramic	
C728	QCF12HP-103	" "	"	
C729	QFM42AK-224	0.22μF 10V	Mylar	
C731	QEB41HM-474	0.47μF 50V	L.L.C. Electrolytic	
C733	QCS11HJ-271	270pF "	Ceramic	

Resistors

Item No.	Part Number	Rating		Description	Maker
R709	QRD181J-683	68k Ω	1/8W	Carbon	
R711	QRD141J-182	1.8k Ω	1/4W	"	
R713	QRG129J-392	3.9k Ω	1/2W	Oxide Metal	
R715	QRG129J-562	5.6k Ω	"	Uninflammable O.M.	
R717	QRD181J-222	2.2k Ω	1/8W	Carbon	
R719	QRX129J-100	10 Ω	1/2W	Uninflammable M.F.	
R721	QRG129J-121	120 Ω	"	Uninflammable O.M.	
R723	QRG129J-121	"	"	"	
R725	QRX129J-100	10 Ω	"	Uninflammable M.F.	
R727	QRX129J-4R7	4.7 Ω	"	"	
R729	QRX129J-4R7	4.7 Ω	1/2W	Uninflammable M.F.	
R731	QRX129J-4R7	"	"	"	
R733	QRX129J-4R7	"	"	"	
R735	QRM054K-R47	0.47 Ω	5W	Metalized Plate	
R737	QRM054K-R47	"	"	"	
R739	QRM054K-R47	"	"	"	
R741	QRM054K-R47	"	"	"	
R743	QRD181J-222	2.2k Ω	1/8W	Carbon	
R745	QRX129J-4R7	4.7 Ω	1/2W	Uninflammable M.F.	
R747	QRX027J-100	10 Ω	2W	Uninflammable	
R749	QRD181J-101	100 Ω	1/8W	Carbon	
R751	QRD181J-471	470 Ω	"	"	
R753	QRD181J-562	5.6k Ω	"	"	
R757	QRD181J-123	12k Ω	"	"	
R771	QRD181J-222	2.2k Ω	"	"	
R773	QRD181J-224	220k Ω	"	"	
R775	QRD181J-563	56k Ω	"	"	
R777	QRG129J-331	330 Ω	1/2W	Uninflammable O.M.	
R779	QRD181J-271	270 Ω	1/8W	Carbon	
R781	QRD141J-182	1.8k Ω	1/4W	"	
R783	QRX129J-100	10 Ω	1/2W	Uninflammable M.F.	
R791	QRD181J-563	56k Ω	1/8W	Carbon	
VR701	QVP4A0B-221	220 Ω		Variable	
VR703	QVP4A0B-221	"		"	

Others

Item No.	Part Number	Rating	Description	Maker
	E03565-3B0		3 Pins Socket	
	E03606-001		Male Contact Plug	
	E03677-002		Transistor Socket	
	E22051-001		Heat Sink	
	E34497-001		Heat Sink Bracket	
	E34498-001		"	
	E49784-002		Connect Pin	

9-(6) TAP-259 Power Amp. C.B. Ass'y

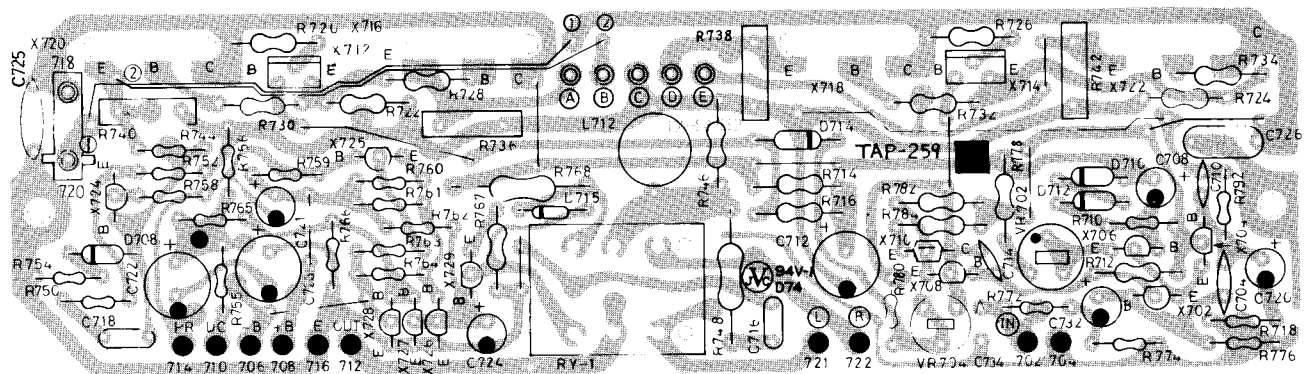

Fig. 31

Transistors

Item No.	Part Number	Rating (Pc)	(fT)	Description	Maker
X702	2SA872AV (E)	300mW	200MHz	Silicon	Hitachi
X704	2SA872AV (E)	"	"	"	"
X706	2SA872AV (E)	"	"	"	"
X708	2SC1775AV (F)	"	"	"	"
X710	2SC1628 (O, Y)	1W	40MHz	"	Toshiba
X712	2SD381 (L, M)	20W	60MHz	"	NEC
X714	2SB536 (L, M)	"	"	"	"
X716	2SC898V (B, C)	80W	15MHz	"	Hitachi
X718	2SA753V (B, C)	"	"	"	"
X720	2SC898V (B, C)	"	"	"	"
X722	2SA753V (B, C)	"	"	"	"
X724	2SC1775AV (F)	300mW	200MHz	"	"
X725	2SA872AV (E)	"	"	"	"
X726	2SC1775AV (F)	"	"	"	"
X727	2SC1775AV (F)	"	"	"	"
X728	2SC1775AV (F)	"	"	"	"
X729	2SD438 (E)	750mW	100MHz	"	Sanyo

Diodes

Item No.	Part Number	Rating	Description	Maker
D708	1S2473		Silicon	Toyo Dengu
D710	1S2473		"	"
D712	1S2473		"	"
D714	SV03		Silicon Varistor	Sanken
D715	SV03		"	"

Coil

Item No.	Part Number	Rating	Description	Maker
L702	E04059-2R7	2.7μH	Choke	

Capacitors

Item No.	Part Number	Rating		Description	Maker
C704	QCS11HJ-471	470pF	50V	Ceramic	
C708	QEW41CA-106	10 μ F	16V	Electrolytic	
C710	QCS11HJ-220	22pF	50V	Ceramic	
C712	QEW41HA-476	47 μ F	"	Electrolytic	
C714	QCS12HJ-330	33pF	"	Ceramic	
C716	QFM41HK-473	0.047 μ F	"	Mylar	
C718	QFM41HK-104	0.1 μ F	"	"	
C720	QEW41CA-226	22 μ F	16V	Electrolytic	
C721	QEW41EA-106	10 μ F	25V	"	
C722	QEW41AA-227	220 μ F	10V	"	
C723	QEW41AA-227	"	"	"	
C724	QEW41AA-476	47 μ F	"	"	
C725	QCF12HP-103	0.01 μ F	50V	Ceramic	
C726	QFM42AK-224	0.22 μ F	10V	Mylar	
C732	QEB41HM-474	0.47 μ F	50V	L.L.C. Electrolytic	
C734	QCS11HJ-271	270pF	"	Ceramic	

Resistors

Item No.	Part Number	Rating		Description	Maker
R710	QRD181J-683	68k Ω	1/8W	Carbon	
R712	QRD141J-182	1.8k Ω	1/4W	"	
R714	QRG129J-392	3.9k Ω	1/2W	Oxide Metal	
R716	QRG129J-562	5.6k Ω	"	Uninflammable	
R718	QRD181J-222	2.2k Ω	1/8W	Carbon	
R720	QRX129J-100	10 Ω	1/2W	Uninflammable M.F.	
R722	QRG129J-121	120 Ω	"	Uninflammable O.M.	
R724	QRG129J-121	"	"	"	
R726	QRX129J-100	10 Ω	"	Uninflammable M.F.	
R728	QRX129J-4R7	4.7 Ω	"	"	
R730	QRX129J-4R7	"	"	"	
R732	QRX129J-4R7	"	"	"	
R734	QRX129J-4R7	"	"	"	
R736	QRM054K-R47	0.47 Ω	5W	Metalized Plate	
R738	QRM054K-R47	"	"	"	
R740	QRM054K-R47	"	"	"	
R742	QRM054K-R47	"	"	"	
R744	QRD181J-222	2.2k Ω	1/8W	Carbon	
R746	QRX129J-4R7	4.7 Ω	1/2W	Uninflammable M.F.	
R748	QRX027J-100	10 Ω	2W	Uninflammable	
R750	QRD181J-101	100 Ω	1/8W	Carbon	
R752	QRD181J-471	470 Ω	"	"	
R754	QRD181J-562	5.6k Ω	"	"	
R755	QRD181J-223	22k Ω	"	"	
R756	QRD181J-223	"	"	"	
R758	QRD181J-123	12k Ω	"	"	
R759	QRD181J-104	100k Ω	"	"	
R760	QRD181J-471	470 Ω	"	"	
R761	QRD181J-224	220k Ω	"	"	
R762	QRD181J-823	82k Ω	"	"	

Resistors

Item No.	Part Number	Rating		Description	Maker
R763	QRD181J-103	10k Ω	1/8W	Carbon	
R764	QRD181J-103	10k Ω	"	"	
R765	QRD181J-562	5.6k Ω	"	"	
R766	QRD181J-822	8.2k Ω	"	"	
R768	QRG027J-681	680 Ω	2W	Oxide Metal Film	
R772	QRD181J-222	2.2k Ω	1/8W	Carbon	
R774	QRD181J-224	220k Ω	"	"	
R776	QRD181J-563	56k Ω	"	"	
R778	QRG129J-331	330 Ω	1/2W	Uninflammable O.M.	
R780	QRD181J-271	270 Ω	1/8W	Carbon	
R782	QRD141J-182	1.8k Ω	1/4W	"	
R784	QRX129J-100	10 Ω	1/2W	Uninflammable M.F.	
R792	QRD181J-563	56k Ω	1/8W	Carbon	
VR702	QVP4A0B-221	220 Ω		Variable	
VR704	QVP4A0B-221	"		"	

Switch

Item No.	Part Number	Rating	Description	Maker
RY-1	ESK1D24-214		Relay	

Others

Item No.	Part Number	Rating	Description	Maker
	E03606-001		Male Contact Plug	
	E03677-002		Transistor Socket	
	E22097-001		Heat Sink	
	E34497-002		Heat Sink Bracket	
	E34498-002		"	

9-(7) TAP-260 Power Supply C.B. Ass'y

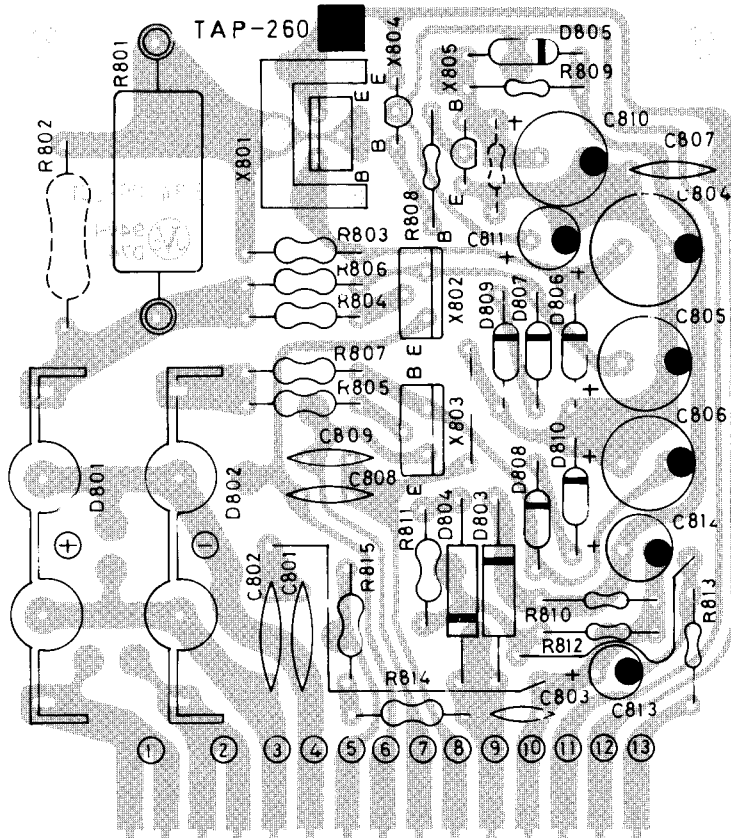

Fig. 32

Transistors

Item No.	Part Number	Rating (Pc)	(ft)	Description	Maker
X801	2SD330V (D, E)	20W	8MHz	Silicon	Sanyo
X802	2SD313V (D, E)	30W	"	"	"
X803	2SB507V (D, E)	"	"	"	"
X804	2SA872AV (E)	300mW	200MHz	"	Hitachi
X805	2SC1775AV (F)	"	"	"	"

Diodes

Item No.	Part Number	Rating	Description	Maker
D801	ESAD01-02C		Silicon	Kyodo Enki
D802	ESAD01-02N		"	"
D803	SIB01-02		"	Fujitsu
D804	SIB01-02		"	"
D805	1S2473		"	Toyo Denki
D806	E0771-12		Zener	Fuji
D807	E0771-12		"	"
D808	E0771-12		"	"
D809	WZ-210		"	JRC
D810	WZ-210		"	"

Capacitors

Item No.	Part Number	Rating		Description	Maker
C801	QCF12HP-103	0.01 μ F	50V	Ceramic	
C802	QCF12HP-103	"	"	"	
C803	QCF11HP-103	"	"	"	
C804	QEW41CA-227	220 μ F	16V	Electrolytic	
C805	QEW41HA-476	47 μ F	50V	"	
C806	QEW41HA-476	"	"	"	
C807	QCF11HP-103	0.01 μ F	"	Ceramic	
C808	QCF11HP-103	"	"	"	
C809	QCF11HP-103	"	"	"	
C810	QEW40JA-227	220 μ F	6.3V	Electrolytic	
C811	QEW41CA-476	47 μ F	16V	"	
C812	QEW41EA-226	22 μ F	25V	"	
C813	QEW41EA-106	10 μ F	"	"	

Resistors

Item No.	Part Number	Rating		Description	Maker
R801	QRF051K-181	180 Ω	5W	Cement	
R803	QRG129J-332	3.3k Ω	1/2W	Oxide Metal Film	
R804	QRG129J-470	47 Ω	"	Uninflammable O.M.	
R805	QRG129J-470	"	"	"	
R806	QRG129J-332	3.3k Ω	"	Oxide Metal Film	
R807	QRG129J-332	"	"	"	
R808	QRD141J-823	82k Ω	1/4W	Carbon	
R809	QRD141J-224	220k Ω	"	"	
R810	QRD126J-102	1k Ω	1/2W	Uninflammable Carbon	
R811	QRD126J-471	470 Ω	"	"	
R812	QRD141J-152	1.5k Ω	1/4W	Carbon	
R813	QRD141J-822	8.2k Ω	"	"	
R814	QRD126J-181	180 Ω	1/2W	Uninflammable Carbon	
R815	QRD126J-150	15 Ω	"	"	

9-(8) TAC-402B
S.E.A. (Sound Effect Amp.)
Control C.B. Ass'y

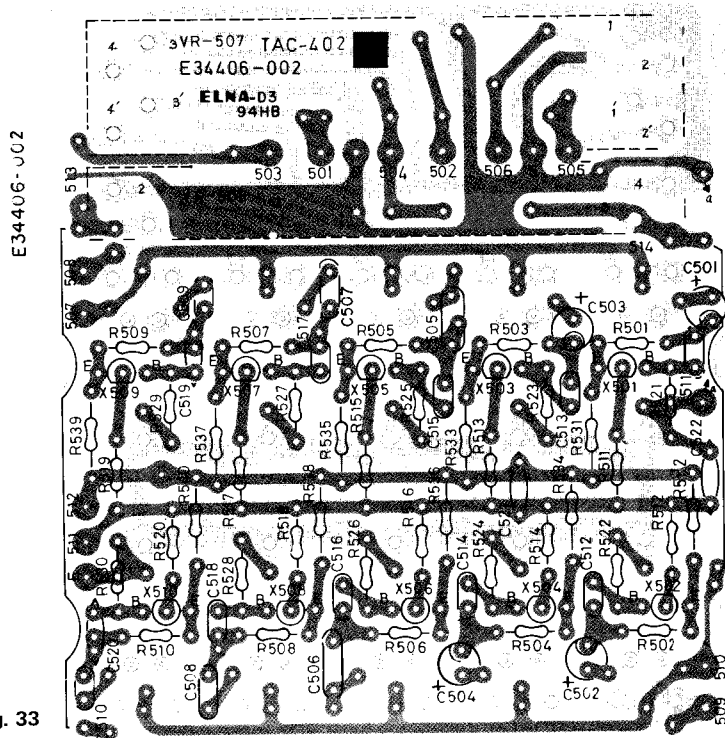

Fig. 33

Transistors

Item No.	Part Number	Rating (Pc)	(ft)	Description	Maker
X501	2SC1775AV (F)	300mW	200MHz	Silicon	Hitachi
X502	2SC1775AV (F)	"	"	"	"
X503	2SC1775AV (F)	"	"	"	"
X504	2SC1775AV (F)	"	"	"	"
X505	2SC1775AV (F)	"	"	"	"
X506	2SC1775AV (F)	"	"	"	"
X507	2SC1775AV (F)	"	"	"	"
X508	2SC1775AV (F)	"	"	"	"
X509	2SC1775AV (F)	"	"	"	"
X510	2SC1775AV (F)	"	"	"	"

Capacitors

Item No.	Part Number	Rating		Description	Maker
C501	QEB41EM-475	4.7 μ F	25V	L. L. C. Electrolytic	
C502	QEB41EM-475	"	"	"	
C503	QEB41HM-474	0.47 μ F	50V	"	
C504	QEB41HM-474	"	"	"	
C505	QFM41HK-124	0.12 μ F	"	Mylar	
C506	QFM41HK-124	"	"	"	
C507	QFM41HK-273	0.027 μ F	"	"	
C508	QFM41HK-273	"	"	"	
C509	QFM41HK-562	5600pF	"	"	
C510	QFM41HK-562	"	"	"	
C511	QFM41HK-223	0.022 μ F	"	"	
C512	QFM41HK-223	"	"	"	
C513	QFM41HK-822	8200pF	"	"	
C514	QFM41HK-822	"	"	"	
C515	QFM41HK-332	3300pF	"	"	
C516	QFM41HK-332	"	"	"	
C517	QFM41HK-102	1000pF	"	"	
C518	QFM41HK-102	"	"	"	
C519	QCS11HJ-681	680 μ F	"	Ceramic	
C520	QCS11HJ-681	"	"	"	
C521	QCF11HP-473	0.047 μ F	"	"	
C522	QCF11HP-473	"	"	"	

Resistors

Item No.	Part Number	Rating		Description	Maker
R501	QRD181J-122	1.2k Ω	1/8W	Carbon	
R502	QRD181J-122	"	"	"	
R503	QRD181J-122	"	"	"	
R504	QRD181J-122	"	"	"	
R505	QRD181J-122	"	"	"	
R506	QRD181J-122	"	"	"	
R507	QRD181J-122	"	"	"	
R508	QRD181J-122	"	"	"	
R509	QRD181J-122	"	"	"	
R510	QRD181J-122	"	"	"	
R511	QRD181J-391	390 Ω	"	"	
R512	QRD181J-391	"	"	"	
R513	QRD181J-391	"	"	"	
R514	QRD181J-391	"	"	"	
R515	QRD181J-391	"	"	"	
R516	QRD181J-391	"	"	"	
R517	QRD181J-391	"	"	"	
R518	QRD181J-391	"	"	"	
R519	QRD181J-391	"	"	"	
R520	QRD181J-391	"	"	"	
R521	QRD181J-134	130k Ω	"	Carbon	
R522	QRD181J-134	"	"	"	
R523	QRD181J-913	91k Ω	"	"	
R524	QRD181J-913	"	"	"	
R525	QRD181J-513	51k Ω	"	"	
R526	QRD181J-513	"	"	"	
R527	QRD181J-333	33k Ω	"	"	
R528	QRD181J-333	"	"	"	
R529	QRD181J-243	24k Ω	"	"	
R530	QRD181J-243	"	"	"	
R531	QRD141J-682	6.8k Ω	1/4W	"	
R532	QRD141J-682	"	"	"	
R533	QRD141J-682	"	"	"	
R534	QRD141J-682	"	"	"	
R535	QRD141J-682	"	"	"	
R536	QRD141J-682	"	"	"	
R537	QRD141J-682	"	"	"	
R538	QRD141J-682	"	"	"	
R539	QRD141J-682	"	"	"	
R540	QRD141J-682	"	"	"	
V R501	QVZ5010-002			Slide Volume	Alps
V R502	QVZ5010-002			"	"
V R503	QVZ5010-002			"	"
V R504	QVZ5010-002			"	"
V R505	QVZ5010-002			"	"
V R506	QVT6C2W-6F5			"	"
V R507	QVT9C2B-5G5E			Slide Variable	"

Others

Item No.	Part Number	Rating	Description	Maker
	E34421-001		S.E.A. Bracket	
	E60865-001		Felt Spacer	

9-(9) TAC-406 S.E.A.(Sound Effect Amp.) Amp. C.B.Ass'y

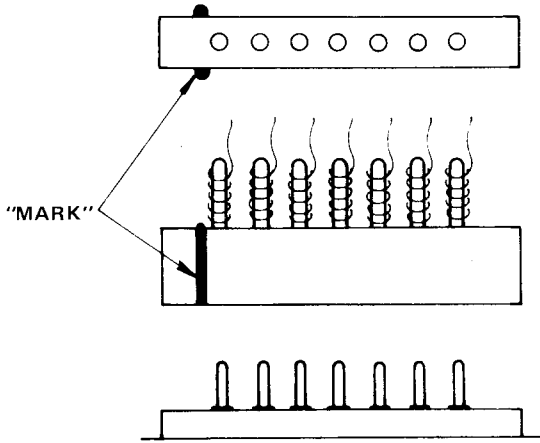
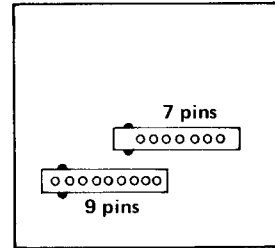

Fig. 34-A

Precaution

Reconnect the female plug to a proper position as indicated "MARK". Refer to Fig. 34-B.



Top View of TAC-406

Fig. 34-B

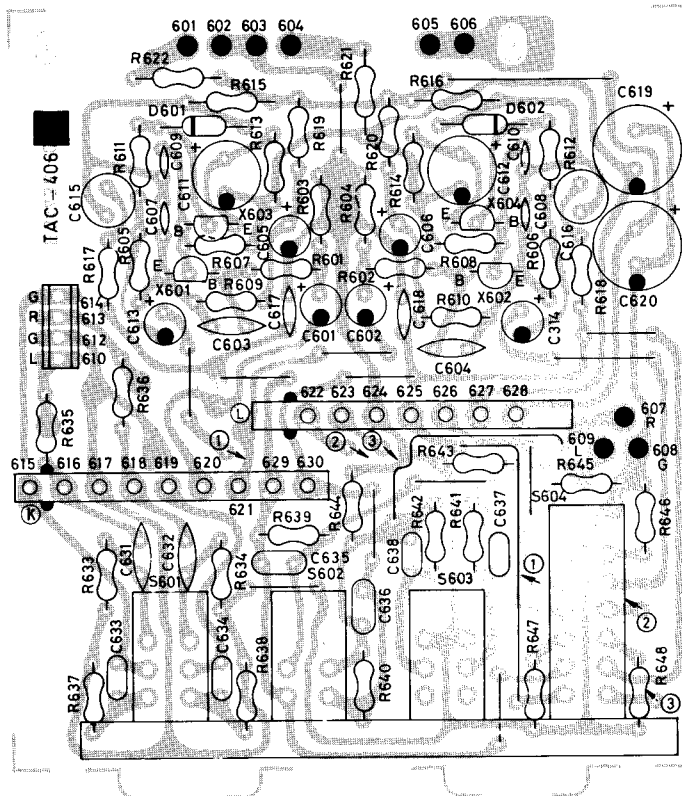

Fig. 35

Transistors

Item No.	Part Number	Rating (Pc)	(ft)	Description	Maker
X601	2SA872AV (E)	300mW	200MHz	Silicon	Hitachi
X602	2SA872AV (E)	"	"	"	"
X603	2SC1775AV (F)	"	"	"	"
X604	2SC1775AV (F)	"	"	"	"

Diodes

Item No.	Part Number	Rating	Description	Maker
D601	1S2473		Silicon	Toyo Dengu
D602	1S2473		"	"

Capacitors

Item No.	Part Number	Rating		Description	Maker
C601	QEB41EM-475	4.7 μ F	25V	L.L.C. Electrolytic	
C602	QEB41EM-475	"	"	"	
C603	QCS11HJ-391	390pF	50V	Ceramic	
C604	QCS11HJ-391	"	"	"	
C605	QEW41AA-476	47 μ F	10V	Electrolytic	
C606	QEW41AA-476	"	"	"	
C607	QCS11HJ-270	27pF	50V	Ceramic	
C608	QCS11HJ-270	"	"	"	
C609	QCS11HJ-3R0	3pF	"	"	
C610	QCS11HJ-3R0	"	"	"	
C611	QEW41AA-107	100 μ F	10V	Electrolytic	
C612	QEW41AA-107	"	"	"	
C613	QEW41AA-476	47 μ F	"	"	
C614	QEW41AA-476	"	"	"	
C615	QZO046-475	4.7MF	50V	N.P. Electrolytic	
C616	QZO046-475	4.7MP	"	"	
C617	QCS11HJ-181	180pF	"	Ceramic	
C618	QCS11HJ-181	"	"	"	
C619	QEW41EA-227	220 μ F	25V	Electrolytic	
C620	QEW41EA-227	"	"	"	
C631	QCS11HJ-271	270pF	50V	Ceramic	
C632	QCS11HJ-271	"	"	"	
C633	QFM41HK-273	0.027 μ F	"	Mylar	
C634	QFM41HK-273	"	"	"	
C635	QFM41HK-563	0.056 μ F	"	"	
C636	QFM41HK-563	"	"	"	
C637	QFM41HK-103	0.01 μ F	"	"	
C638	QFM41HK-103	"	"	"	

Resistors

Item No.	Part Number	Rating		Description	Maker
R601	QRD181J-102	1k Ω	1/8W	Carbon	
R602	QRD181J-102	"	"	"	
R603	QRD181J-184	180k Ω	"	"	
R604	QRD181J-184	"	"	"	
R605	QRD181J-682	6.8k Ω	"	"	
R606	QRD181J-682	"	"	"	
R607	QRD181J-823	82k Ω	"	"	
R608	QRD181J-823	"	"	"	
R609	QRD181J-222	2.2k Ω	"	"	
R610	QRD181J-222	"	"	"	
R611	QRD181J-103	10k Ω	"	"	
R612	QRD181J-103	"	"	"	
R613	QRD181J-102	1k Ω	"	"	
R614	QRD181J-102	"	"	"	

Resistors

Item No.	Part Number	Rating		Description	Maker
R615	QRD141J-562	5.6k Ω	1/4W	Carbon	
R616	QRD141J-562	"	"	"	
R617	QRD181J-682	6.8k Ω	1/8W	"	
R618	QRD181J-682	"	"	"	
R619	QRD181J-104	100k Ω	"	"	
R620	QRD181J-104	"	"	"	
R621	QRX129J-100	10 Ω	1/2W	Unflamable M.F.	
R622	QRX129J-100	"	"	"	
R633	QRD181J-564	560k Ω	1/8W	Carbon	
R634	QRD181J-564	"	"	"	
R635	QRD181J-332	3.3k Ω	"	"	
R636	QRD181J-332	"	"	"	
R637	QRD181J-153	15k Ω	"	"	
R638	QRD181J-153	"	"	"	
R639	QRD181J-224	220k Ω	"	"	
R640	QRD181J-224	"	"	"	
R641	QRD181J-224	"	"	"	
R642	QRD181J-224	"	"	"	
R643	QRD181J-273	27k Ω	"	"	
R644	QRD181J-273	"	"	"	
R645	QRD181J-273	"	"	"	
R646	QRD181J-273	"	"	"	
R647	QRD181J-273	"	"	"	
R648	QRD181J-273	"	"	"	

Others

Item No.	Part Number	Rating	Description	Maker
	E03628-7		7 Pins Plug	
	E03628-9		9 Pins Plug	
	E49545-001		Pin	
	E49766-002		4 Pins Socket	
	QSP0249-103		Push Switch	

9-(10) TAC-408B Speaker C.B. Ass'y

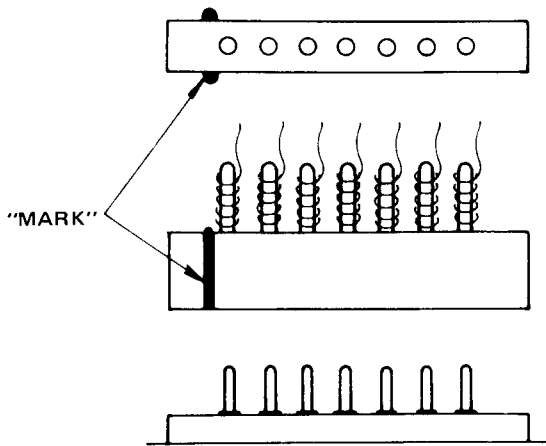
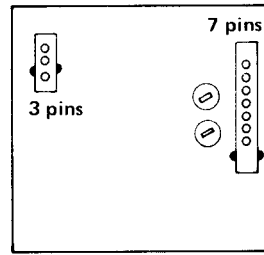

Fig. 36-A



Precaution
Reconnect the female plug to a proper position as indicated "MARK". Refer to Fig. 36-B.

Top View of TAC-408

Fig. 36-B

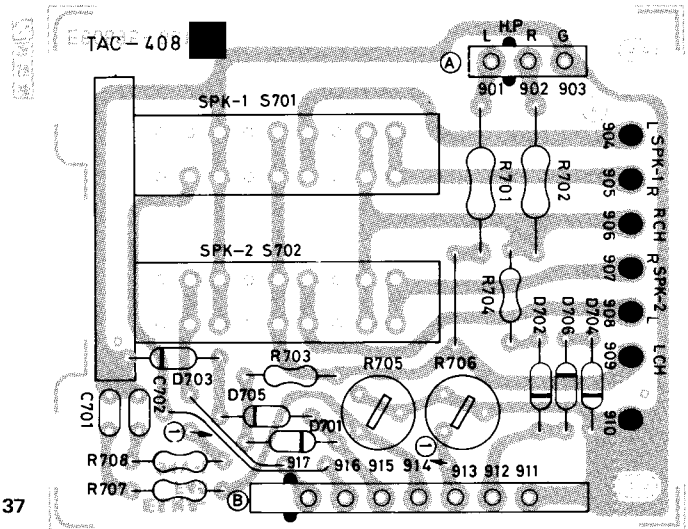

Fig. 37

Diodes

Item No.	Part Number	Rating	Description	Maker
D701	1S188FM		Germanium	Sanyo
D702	1S188FM		"	"
D703	1S188FM		"	"
D704	1S188FM		"	"
D705	1S188FM		"	"
D706	1S188FM		"	"

Capacitors

Item No.	Part Number	Rating	Description	Maker
C701	QFM41HK-223	0.022 μ F	50V	Mylar
C702	QFM41HK-223	"	"	"

Resistors

Item No.	Part Number	Rating	Description	Maker
R701	QRG027J-221	220 Ω	2W	Oxide Metal Film
R702	QRG027J-221	"	"	"
R703	QRD141J-562	5.6k Ω	1/4W	Carbon
R704	QRD141J-562	"	"	"
R705	QVP4A0B-222	2.2k Ω	1/8W	Variable
R706	QVP4A0B-222	"	"	"
R707	QRD141J-821	820 Ω	1/4W	Carbon
R708	QRD141J-821	"	"	"

Others

Item No.	Part Number	Rating	Description	Maker
	E03628-3		3 Pins Plug	
	E03628-7		7 Pins Plug	
	QSP0229-003		Push Switch	

9-(11) TAC-414 Selector C.B. Ass'y

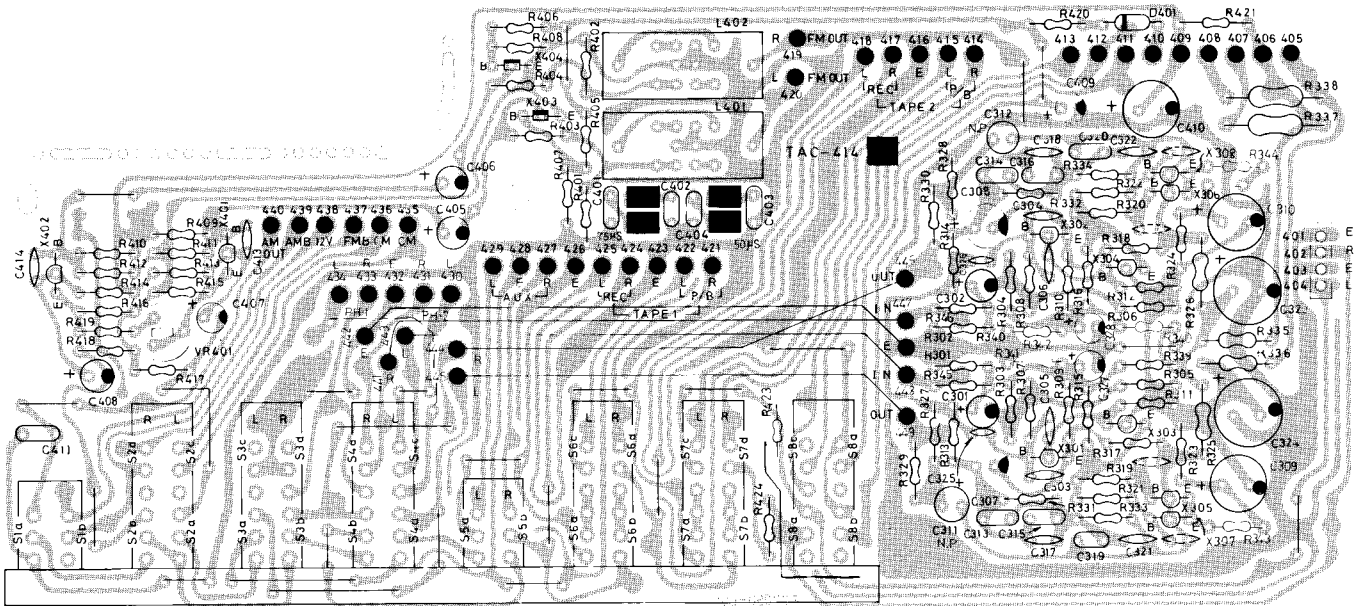

Fig. 38

Transistors

Item No.	Part Number	Rating (Pc)	(fT)	Description	Maker
X301	2SA872AV (E)	300mW	200MHz	Silicon	Hitachi
X302	2SA872AV (E)	"	"	"	"
X303	2SA872AV (E)	"	"	"	"
X304	2SA872AV (E)	"	"	"	"
X305	2SC1775AV (F)	"	"	"	"
X306	2SC1775AV (F)	"	"	"	"
X307	2SC1775AV (F)	"	"	"	"
X308	2SC1775AV (F)	"	"	"	"
X401	2SC1775AV (F)	"	"	"	"
X402	2SC1775AV (F)	"	"	"	"
X403	2SC458 (C)	200mW	230MHz	"	"
X404	2SC458 (C)	"	"	"	"

Diode

Item No.	Part Number	Rating	Description	Maker
D401	1S2473		Silicon	Toyo Dengu

Coils

Item No.	Part Number	Rating	Description	Maker
L401	E03427-009		Low Pass Filter	
L402	E03427-009		"	

Capacitors

Item No.	Part Number	Rating	Description	Maker
C301	QEB41EM-335	3.3μF	L.L.C. Electrolytic	
C302	QEB41EM-335	"	"	
C303	QCS11HJ-331	330pF	Ceramic	
C304	QCS11HJ-331	"	"	
C305	QCS11HJ-220	22pF	"	

Capacitors

Item No.	Part Number	Rating		Description	Maker
C306	QCS11HJ-220	22pF	50V	Ceramic	
C307	QEW41EA-106	10 μ F	25V	Electrolytic	
C308	QEW41EA-106	"	"	"	
C309	QEW41CA-107	100 μ F	10V	"	
C310	QEW41CA-107	"	"	"	
C311	QEZ0046-475	4.7 μ F	50V	Non Pole Electrolytic	
C312	QEZ0046-475	"	"	"	
C313	QFM41HJ-272	2700pF	"	Mylar	
C314	QFM41HJ-272	"	"	"	
C315	QFM41HJ-472	4700pF	"	"	
C316	QFM41HJ-472	"	"	"	
C317	QCS11HJ-271	270pF	"	Ceramic	
C318	QCS11HJ-271	"	"	"	
C319	QFM41HJ-222	2200pF	"	Mylar	
C320	QFM41HJ-222	"	"	"	
C321	QCS11HJ-101	100pF	"	Ceramic	
C322	QCS11HJ-101	"	"	"	
C323	QEW41VA-227	220 μ F	35V	Electrolytic	
C324	QEW41VA-227	"	"	"	
C325	QCS11HJ-330	33pF	50V	Ceramic	
C326	QCS11HJ-330	"	"	"	
C401	QFM41HJ-153	0.015 μ F	"	Mylar	
C402	QFM41HJ-153	"	"	"	
C403	QFM41HJ-103	0.01 μ F	"	"	
C404	QFM41HJ-103	"	"	"	
C405	QEB41HM-474	0.47 μ F	"	L.L.C. Electrolytic	
C406	QEB41HM-474	"	"	"	
C407	QEB41HM-105	1 μ F	"	"	
C408	QEB41HM-105	"	"	"	
C409	QEB41HM-474	0.47 μ F	"	"	
C410	QEW41VA-107	100 μ F	35V	Electrolytic	
C411	QFM41HK-333	0.033 μ F	50V	Mylar	
C413	QCS11HJ-101	100pF	"	Ceramic	
C414	QCS11HJ-101	"	"	"	

Resistors

Item No.	Part Number	Rating		Description	Maker
R301	QRD141J-473SL	47k Ω	1/4W	Carbon	
R302	QRD141J-473SL	"	"	"	
R303	QRD141J-334SL	330k Ω	"	"	
R304	QRD141J-334SL	"	"	"	
R305	QRD141J-105SL	1M Ω	"	"	
R306	QRD141J-105SL	"	"	"	
R307	QRD141J-102SL	1k Ω	"	"	
R308	QRD141J-102SL	"	"	"	
R309	QRD141J-124SL	120k Ω	"	"	
R310	QRD141J-124SL	"	"	"	
R311	QRD141J-683SL	68k Ω	"	"	
R312	QRD141J-683SL	"	"	"	
R313	QRD141J-471SL	470 Ω	"	"	
R314	QRD141J-471SL	"	"	"	
R315	QRD141J-473SL	47k Ω	"	"	

Resistors

Item No.	Part Number	Rating		Description	Maker
R316	QRD141J-473SL	47k Ω	1/4W	Carbon	
R319	QRD141J-102SL	1k Ω	"	"	
R320	QRD141J-102SL	"	"	"	
R321	QRD141J-102SL	"	"	"	
R322	QRD141J-102SL	"	"	"	
R323	QRD141J-821SL	820 Ω	"	"	
R324	QRD141J-821SL	"	"	"	
R325	QRG129J-472	4.7k Ω	1/2W	Uninflammable O.M.	
R326	QRG129J-472	"	"	"	
R327	QRD141J-473SL	47k Ω	1/4W	Carbon	
R328	QRD141J-473SL	"	"	"	
R329	QRD141J-471SL	470 Ω	"	"	
R330	QRD141J-471SL	"	"	"	
R331	QRD141J-514SL	510k Ω	"	"	
R332	QRD141J-514SL	"	"	"	
R333	QRD141J-333	33k Ω	"	"	
R334	QRD141J-333	"	"	"	
R335	QRG129J-221	220 Ω	1/2W	Uninflammable O.M.	
R336	QRG129J-221	"	"	"	
R337	QRG017J-331	330 Ω	1W	O.M.F.	
R338	QRG017J-331	"	"	"	
R339	QRD141J-123SL	12k Ω	1/4W	Carbon	
R340	QRD141J-223SL	22k Ω	"	"	
R401	QRD141J-392SL	3.9k Ω	"	"	
R402	QRD141J-392SL	"	"	"	
R403	QRD141J-272SL	2.7k Ω	"	"	
R404	QRD141J-272SL	"	"	"	
R405	QRD141J-223SL	22k Ω	"	"	
R406	QRD141J-223SL	"	"	"	
R407	QRD141J-333SL	33k Ω	"	"	
R408	QRD141J-333SL	"	"	"	
R409	QRD141J-474SL	470k Ω	"	"	
R410	QRD141J-474SL	"	"	"	
R411	QRD141J-393SL	39k Ω	"	"	
R412	QRD141J-393SL	"	"	"	
R413	QRD141J-562SL	5.6k Ω	"	"	
R414	QRD141J-562SL	"	"	"	
R415	QRD141J-471SL	470 Ω	"	"	
R416	QRD141J-471SL	"	"	"	
R417	QRD141J-104SL	10k Ω	"	"	
R418	QRD141J-104SL	"	"	"	
R419	QRD141J-123SL	12k Ω	"	"	
R420	QRD141J-123SL	"	"	"	
R421	QRD141J-561	560 Ω	"	"	

Others

Item No.	Part Number	Rating	Description	Maker
	E49545-001		Pin	
	E49766-001		4 Pins Socket	
	QSP0289-106		Push Switch	

9-(12) TFM-910GUA2 FM/AM Tuner C.B. Ass'y

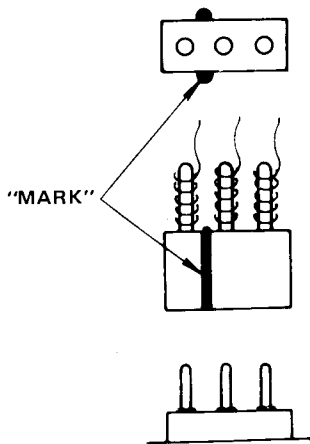
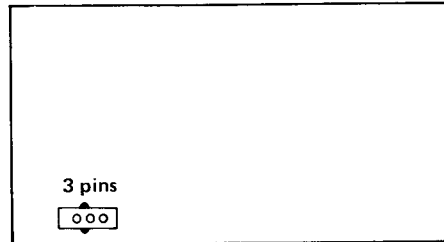

Fig. 39-A

Precaution

Reconnect the female plug to a proper position as indicated "MARK". Refer to Fig. 39-B.



Top View of TFM-910GUA2

Fig. 39-B

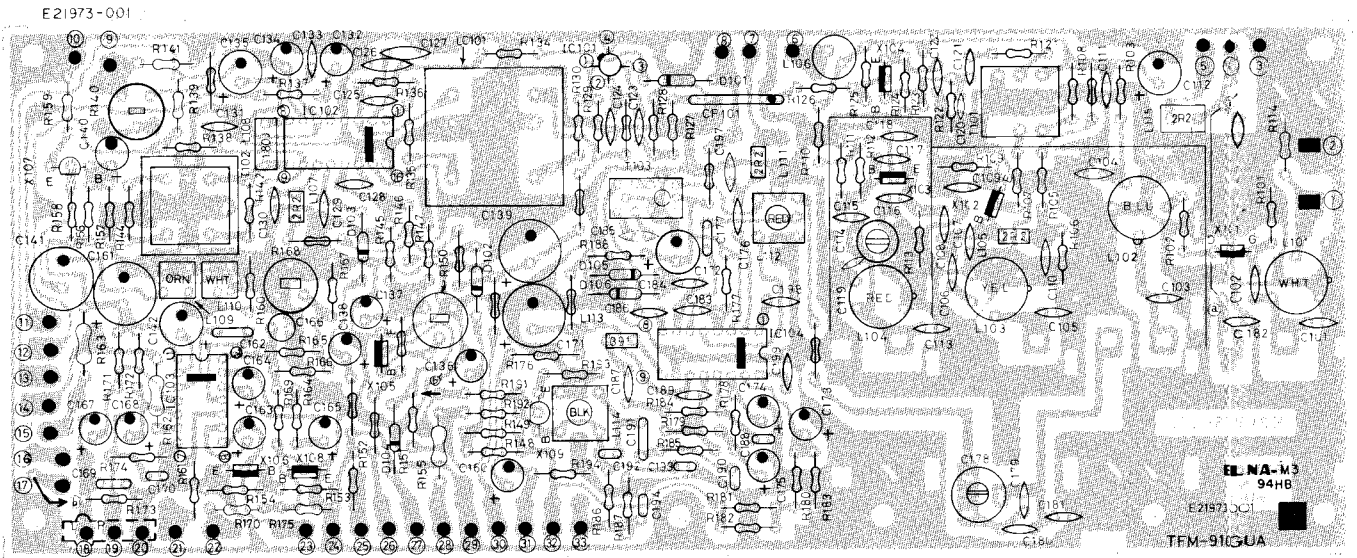

Fig. 40

Transistors

Item No.	Part Number	Rating		Description	Make r
		pc	ft		
X101	2SK55D	IDSS: 14mA, NF: 3.5dB (f=100MHz)		F.E.T.	Hitachi
X102	2SC535 (C)	100mW	700MHz	Silicon	"
X103	2SC1342 (B)	"	250MHz	"	"
X104	2SC535 (B)	100mW	700MHz	"	"
X105	2SC458 (C)	200mW	230MHz	"	"
X106	2SC458 (C)	"	"	"	"
X107	2SC1775AV (F)	300mW	200MHz	"	"
X108	2SC458 (C)	200mW	230MHz	"	"
X109	2SC1775AV (F)	300mW	200MHz	"	"

Integrated Circuits

Item No.	Part Number	Rating	Description	Make r
IC101	LA1221		I.C.	Hitachi
IC102	HA1137W	550mW	"	"
IC103	HA1156W	400mW	"	"
IC104	HA1197	450mW	"	"

Filters

Item No.	Part Number	Rating	Description	Maker
CF101	E03609-002R		Ceramic Filter	
LC101	E03618-001		L.C. Filter	

Diodes

Item No.	Part Number	Rating	Description	Maker
D101	1S2473		Silicon	Toyo Dengu
D102	1S2473		"	"
D103	1S2473		"	"
D104	1S2473		"	"
D105	1S2473		"	"
D106	1S2473		"	"

Coils

Item No.	Part Number	Rating	Description	Maker
L101	E03477-031		RF Coil (White)	
L102	E03477-036		" (Blue)	
L103	E03477-033		" (Yellow)	
L104	E03477-034		" (Red)	
L105	E03522-2R2KY	2.2 μ H	Choke Coil	
L106	E03566-223		Ferry Inductor	
L107	E03522-2R2KY	2.2 μ H	Choke Coil	
L108	E03522-180J	18 μ H	FM Detector Coil	
L109	E03406-002		Trap Filter (Orange)	
L110	E03406-003		" (White)	
L111	E03522-2R2KY	2.2 μ H	Choke Coil	
L112	E03079-29		AM OSC Coil (Red)	
L113	E03522-391KY	390 μ H	Choke Coil	
L114	E03407-005		Multiplex Coil (Black)	
L115	E03522-2R2KY	2.2 μ H	Choke Coil	
T101	E03134-023		FM I.F. Transformer	
T102	E03134-020B		"	
T103	E03613-003		AM I.F. Transformer	

Capacitors

Item No.	Part Number	Rating	Description	Maker
C101	QAA2245-001		Variable Tuning	
C101	QCS11HJ-150	15pF	Ceramic	
C102	QCS11HJ-330	33pF	"	
C103	QCS11HJ-180	18pF	"	
C104	QCF11HP-223A	0.022 μ F	"	
C105	QCS11HJ-180	18pF	"	
C106	QCS11HJ-4R0	4pF	"	
C107	QCS11HJ-4R0	"	"	
C108	QCT05CG-2R0	2pF	"	
C109	QCF11HP-223A	0.022 μ F	"	
C110	QCS11HJ-101	100pF	"	
C111	QCF11HP-223A	0.022 μ F	"	
C113	QCT05SG-220	22pF	"	
C114	QAT3001-014		Trimmer	
C115	QCT05CG-7R0	7pF	Ceramic	
C116	QCT05CG-100	10pF	"	
C117	QCT05CG-220	22pF	"	
C118	QCF11HP-223A	0.022 μ F	"	
C121	QCF11HP-223A	"	"	
C122	QCF11HP-223A	"	"	

Capacitors

Item No.	Part Number	Rating		Description	Maker
C123	QCF11HP-223A	0.022 μ F	50V	Ceramic	
C124	QCF11HP-223A	"	"	"	
C125	QCF11HP-223A	"	"	"	
C126	QCZ0107-473	0.047 μ F	25V	"	
C127	QCZ0107-473	"	"	"	
C128	QCS11HJ-151	150pF	50V	"	
C129	QCF11HP-223A	0.022 μ F	"	"	
C130	QCF11HP-223A	"	"	"	
C131	QCF11HP-223A	"	"	"	
C132	QEB41EM-475	4.7 μ F	25V	L.L.C. Electrolytic	
C133	QCS11HJ-330	33pF	50V	Ceramic	
C134	QEW41HA-105	1 μ F	"	Electrolytic	
C135	QEW41CA-226	22 μ F	16V	"	
C136	QEW41AA-476	47 μ F	10V	"	
C137	QEW41HA-474	0.47 μ F	50V	"	
C138	QEW41HA-105	1 μ F	"	"	
C139	QEW41CA-227	220 μ F	16V	"	
C140	QEW41CA-226	22 μ F	"	Electrolytic	
C141	QEW41CA-107	100 μ F	"	"	
C142	QEB41EM-106	10 μ F	25V	L.L.C. Electrolytic	
C160	QEB41HM-224	0.22 μ F	50V	"	
C161	QEW41CA-227	220 μ F	16V	Electrolytic	
C162	QFM41HK-473	0.047 μ F	50V	Mylar	
C163	QEB41HM-105	1 μ F	"	L.L.C. Electrolytic	
C164	QEB41HM-224	0.22 μ F	"	"	
C165	QEB41EM-106	10 μ F	25V	"	
C166	QFS42BJ-471	470pF	125V	Polystyrene	
C167	QEB41HM-105	1 μ F	50V	L.L.C. Electrolytic	
C168	QEB41HM-105	"	"	"	
C169	QFM41HK-102	1000pF	"	Mylar	
C170	QFM41HK-102	"	"	"	
C171	QEW41CA-227	220 μ F	16V	Electrolytic	
C172	QEW41CA-476	47 μ F	"	"	
C173	QEW41AA-476	47 μ F	10V	"	
C174	QEW41HA-105	1 μ F	50V	"	
C175	QEW41CA-106	10 μ F	16V	"	
C176	QCF11HP-223A	0.022 μ F	50V	Ceramic	
C177	QFM41HK-103	0.01 μ F	"	Mylar	
C178	QAT3001-006			Trimmer	
C179	QCS11HJ-560	56pF	50V	Ceramic	
C180	QSC11HJ-271	270pF	"	"	
C181	QCS11HJ-180	18pF	"	"	
C182	QCS11HJ-5R0	5pF	"	Ceramic	
C183	QCF11HP-223A	0.022 μ F	"	"	
C184	QCF11HP-223A	"	"	"	
C185	QCS11HJ-470	47pF	"	"	
C186	QCF11HP-223A	0.022 μ F	"	Ceramic	
C187	QCS11HJ-331	330pF	"	"	
C188	QFM41HK-102	1000pF	"	Mylar	
C189	QCF11HP-223A	0.022 μ F	"	Ceramic	
C190	QFM41HK-222	2200pF	"	Mylar	
C191	QFM41HK-473	0.047 μ F	"	"	
C192	QFM41HK-103	0.01 μ F	"	"	
C193	QFM41HK-222	2200pF	"	"	
C195	QCF11HP-223A	0.022 μ F	"	Ceramic	
C197	QCS11HJ-470	47pF	"	"	
C199	QCZ0107-473	0.047 μ F	25V	"	

Resistors

Item No.	Part Number	Rating		Description	Maker
R101	QRD181J-105	1M Ω	1/8W	Carbon	
R102	QRD181J-820	82 Ω	"	"	
R103	QRD181J-820	"	"	"	
R105	QRD181J-223	22k Ω	"	"	
R106	QRD181J-392	3.9k Ω	"	"	
R107	QRD181J-470	47 Ω	"	"	
R108	QRD181J-123	12k Ω	"	"	
R109	QRD181J-102	1k Ω	"	"	
R110	QRD181J-331	330 Ω	"	"	
R111	QRD181J-123	12k Ω	"	"	
R112	QRD181J-822	8.2k Ω	"	"	
R113	QRD181J-152	1.5k Ω	"	"	
R114	QRD181J-682	6.8k Ω	"	"	
R121	QRD181J-181	180 Ω	"	"	
R122	QRD181J-332	3.3k Ω	"	"	
R123	QRD181J-562	5.6k Ω	"	"	
R124	QRD181J-102	1k Ω	"	"	
R125	QRD181J-271	270 Ω	"	"	
R126	QRD181J-221	220 Ω	"	"	
R127	QRD181J-181	180 Ω	"	"	
R128	QRD181J-331	330 Ω	"	"	
R129	QRD181J-102	1k Ω	"	"	
R130	QRD181J-221	220 Ω	"	"	
R134	QRD181J-334	330k Ω	"	"	
R135	QRD181J-271	270 Ω	"	"	
R136	QRD181J-391	390 Ω	"	"	
R137	QRD181J-123	12k Ω	"	"	
R138	QRD181J-822	8.2k Ω	"	"	
R139	QRD181J-271	270 Ω	"	"	
R140	QVP4AOB-223	22k Ω		Variable	
R141	QRD181J-473	47k Ω	1/8W	Ceramic	
R142	QRD181J-562	5.6k Ω	"	"	
R144	QRD181J-332	3.3k Ω	"	Carbon	
R145	QRD181J-332	3.3k Ω	"	Carbon	
R146	QRD181J-822	8.2k Ω	"	"	
R147	QRD181J-683	68k Ω	"	"	
R148	QRD181J-222	2.2k Ω	"	"	
R149	QRD181J-682	6.8k Ω	"	"	
R150	QVP4AOB-473	47k Ω		Variable	
R151	QRD181J-223	22k Ω	1/8W	Carbon	
R152	QRD181J-223	"	"	"	
R153	QRD181J-563	56k Ω	"	"	
R154	QRD181J-563	"	"	"	
R155	QRD126J-100	10 Ω	1/2W	Uninflammable Carbon	
R156	QRD181J-823	82k Ω	1/8W	Carbon	
R157	QRD181J-273	27k Ω	"	"	
R158	QRD181J-222	2.2k Ω	"	"	
R159	QRD181J-681	680 Ω	"	"	
R160	QRD181J-272	2.7k Ω	"	"	

Resistors

Item No.	Part Number	Rating		Description	Maker
R161	QRD181J-105	1M Ω	1/8W	Carbon	
R162	QRD126J-181	180 Ω	1/2W	Uninflamable Carbon	
R163	QRD126J-101	100 Ω	"	"	
R164	QRD181J-102	1k Ω	1/8W	Carbon	
R165	QRD181J-183	18k Ω	"	"	
R166	QRD181J-394	390k Ω	"	"	
R167	QRD181J-153	15k Ω	"	"	
R168	QVP4AOB-472	4.7k Ω		Variable	
R169	QRD181J-392	3.9k Ω	1/8W	Carbon	
R170	QRD181J-103	10k Ω	"	"	
R171	QRD181J-392	3.9k Ω	"	"	
R172	QRD181J-392	"	"	"	
R173	QRD181J-563	56k Ω	"	"	
R174	QRD181J-563	"	"	"	
R175	QRD181J-392	3.9k Ω	"	"	
R176	QRD141J-221	220 Ω	1/4W	"	
R177	QRD181J-152	1.5k Ω	1/8W	"	
R178	QRD181J-103	10k Ω	"	"	
R179	QRD181J-103	"	"	"	
R180	QRD181J-561	560 Ω	"	"	
R181	QRD181J-181	180 Ω	"	"	
R182	QRD181J-181	"	"	"	
R184	QRD181J-331	330 Ω	"	"	
R185	QRD181J-272	2.7k Ω	"	"	
R186	QRD181J-333	33k Ω	"	"	
R187	QRD181J-273	27k Ω	"	"	
R188	QRD181J-151	150 Ω	"	"	
R191	QRD181J-152	1.5k Ω	"	"	
R192	QRD181J-224	220k Ω	"	"	
R193	QRD181J-102	1k Ω	"	"	
R194	QRD181J-563	56k Ω	"	"	

Others

Item No.	Part Number	Rating	Description	
	E03606-001		Male Contact Pin	
	E49829-002		Shield Case	
	E60091-002		Shield Plate	
	E60092-001		Shield Plate	

10. Packing Materials List

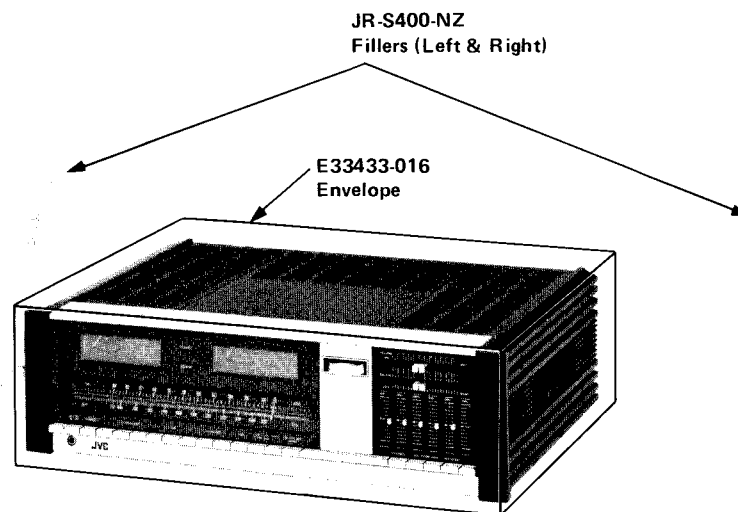

Fig. 41

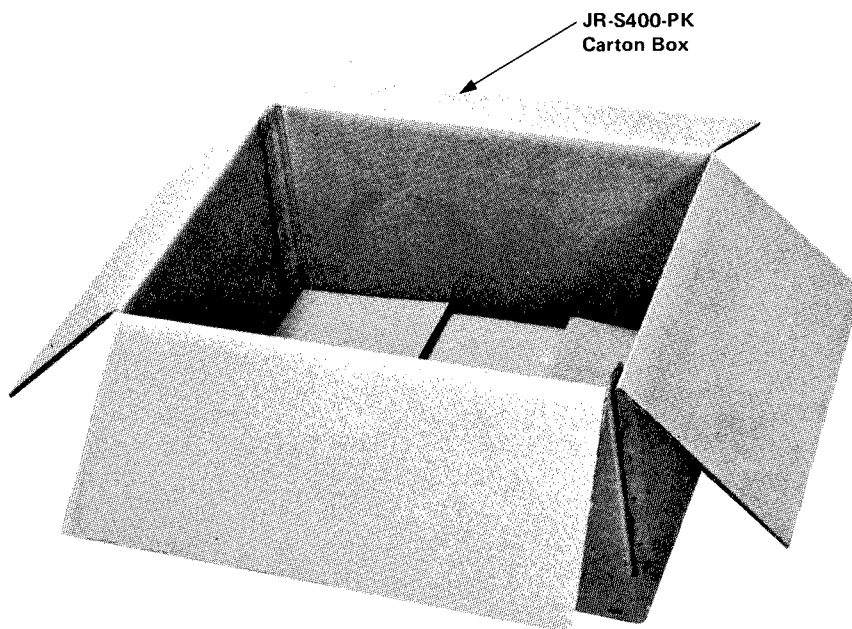
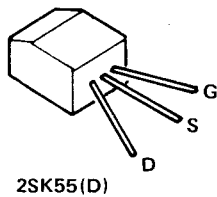

Fig. 42

11. Accessories List

Part Number	Description	Q'ty
E30580-514A	Instruction Book	1
E64207-002	Envelope for Inst. Book	1
BT20020	Warranty Card	1

12. Transistor, I.C. and Diode Lead Identification



2SK55(D)

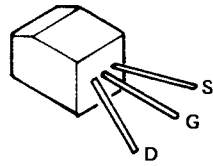

2SK40

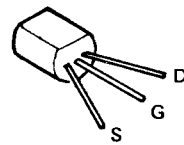

2SK30

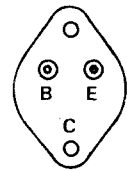

2SD425
2SB555

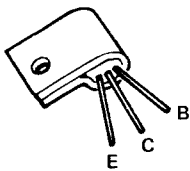

2SC853

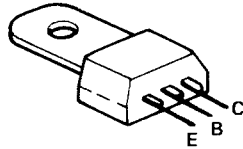

2SC1628(O,Y)
2SA828(O,Y)

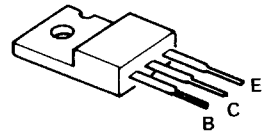

2SD381
2SB536
2SD313V
2SB507V

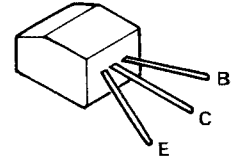

2SC458
2SC535
2SC1342

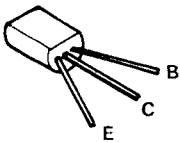

2SC1775AV(F)
2SA872AV(E)
2SD599(F)

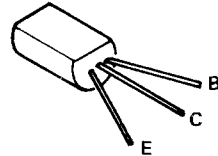

2SD438
2SB560

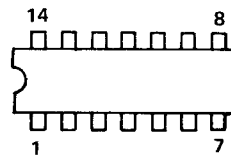

HA1156W

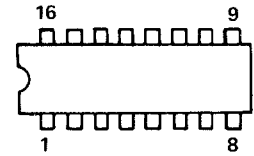

HA1197W
HA1137W

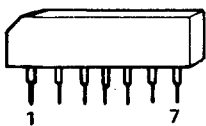

TA7122AP

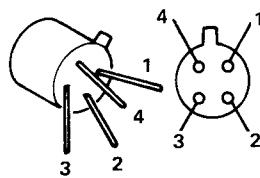

LA1221

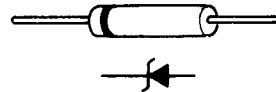

WZ130
WZ210
WZ070
WZ090



IS2473
IS188FM

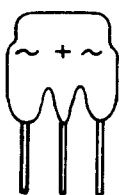

ESAB02-02C
ESAB02-02N

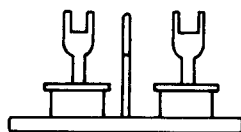

SG5TR
(SG5TS)

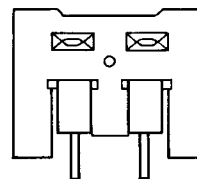

ESAD01-02C
ESAD01-02N

13. Parts List with Specified Numbers for Designated Areas

Page	Item No.	Description	Original	For European Countries	For Australia	For Canada	For Other Countries and PACEX
7	28	Power Switch Bracket (Power Switch)	QSU1135-001 E60860-002	QSP2111-011 E60860-003	QSP2111-011 E60860-003	QSU1135-001 E60860-002	QSU1135-001 E60860-002
8	10	Power Cord	QMP1200-244	QMP3800-240 E03544-001 (SEMCO only)	E03551-002	QMP1200-244	QMP1200-244
8	9	Cord Stopper Fuse (Primary)	QHS3876-162 QMF61M2-5R0	QHS3876-162 QMF51A2-3R15	QHS6374-252 QMF51A2-3R15	QHS3876-162 QMF60R1-5R0	QHS3876-162 QMF60R1-5R0 QMF60R1-3R3 (For 220V/240V only)
		Fuse (Secondary) 8A 1A	QMF61U1-8R0 QMF61U1-1R0	QMF51A2-8R0 QMF51A2-1R0	QMF51A2-8R0 QMF51A2-1R0	QMF60R1-8R0 QMF60R1-1R0	QMF60R1-8R0 QMF60R1-1R0
6	4	Power Transformer	E03077-22	E03077-22B	E03077-22B	E03077-22	E03077-22B
15	9-(1)	AC Block Ass'y	TPS-48	TPS-64	TPS-64	TPS-48	TPS-48B
15	9-(2)	AC Fuse C.B. Ass'y	TPS-49C	TPS-49D	TPS-49D	TPS-49C	TPS-49C
38	11	Instruction Book	E30580-514A	E30580-514A E30580-515A (Germany) E30580-516A (France)	E30580-514A	E30580-514A E30580-516A (For French)	E30580-514A
38	11	Warranty Card	BT20020			BT20008	BT20014 (PACEX only)

14. Schematic Diagram

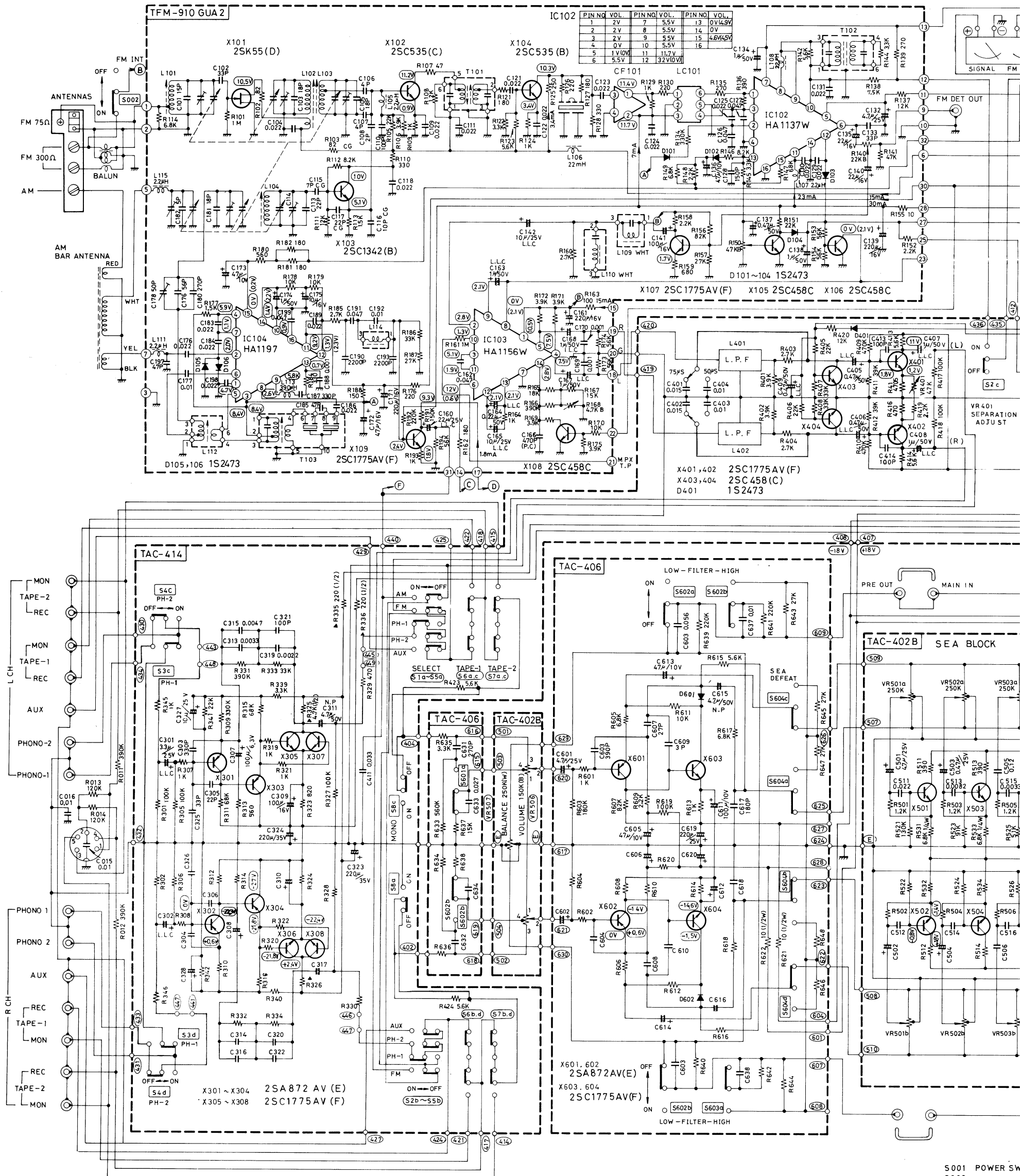

Circuit Board Ass'y Locations

C.B. Ass'y	Description	Page
TPS-48	AC Block C.B. Ass'y	15
TPS-49C	Fuse C.B. Ass'y	15
TPS-50	Meter Lamp C.B. Ass'y	16
TPS-68A	Stabilizer C.B. Ass'y	16
TAP-258	Power Amp. C.B. Ass'y	17
TAP-259	Power Amp. C.B. Ass'y	19
TAP-260	Power Amp. C.B. Ass'y	22
TAC-402B	S.E.A. (Sound Effect Amp.) Control C.B. Ass'y	24
TAC-406	S.E.A. (Sound Effect Amp.) Amp. C.B. Ass'y	26
TAC-408B	Speaker C.B. Ass'y	29
TAC-414	Selector C.B. Ass'y	30
TFM-910GUA2	FM/AM Tuner C.B. Ass'y	33

Precaution
After replacement of output and driver transistors, check the bias adjustment (see power amplifier adjustment on page 13).

Transistor, IC and Diode Lead Identification

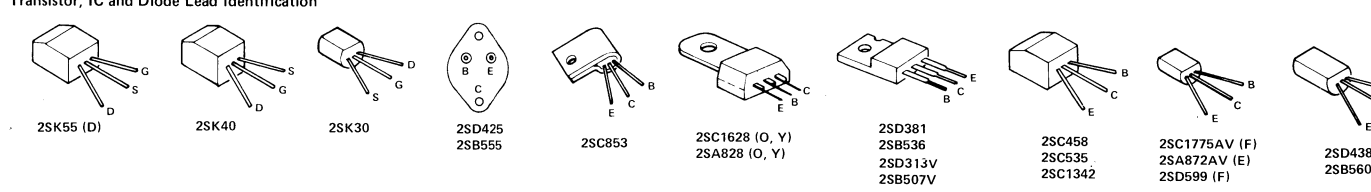

S001 POWER SW
S002 INT ANTEN
S003

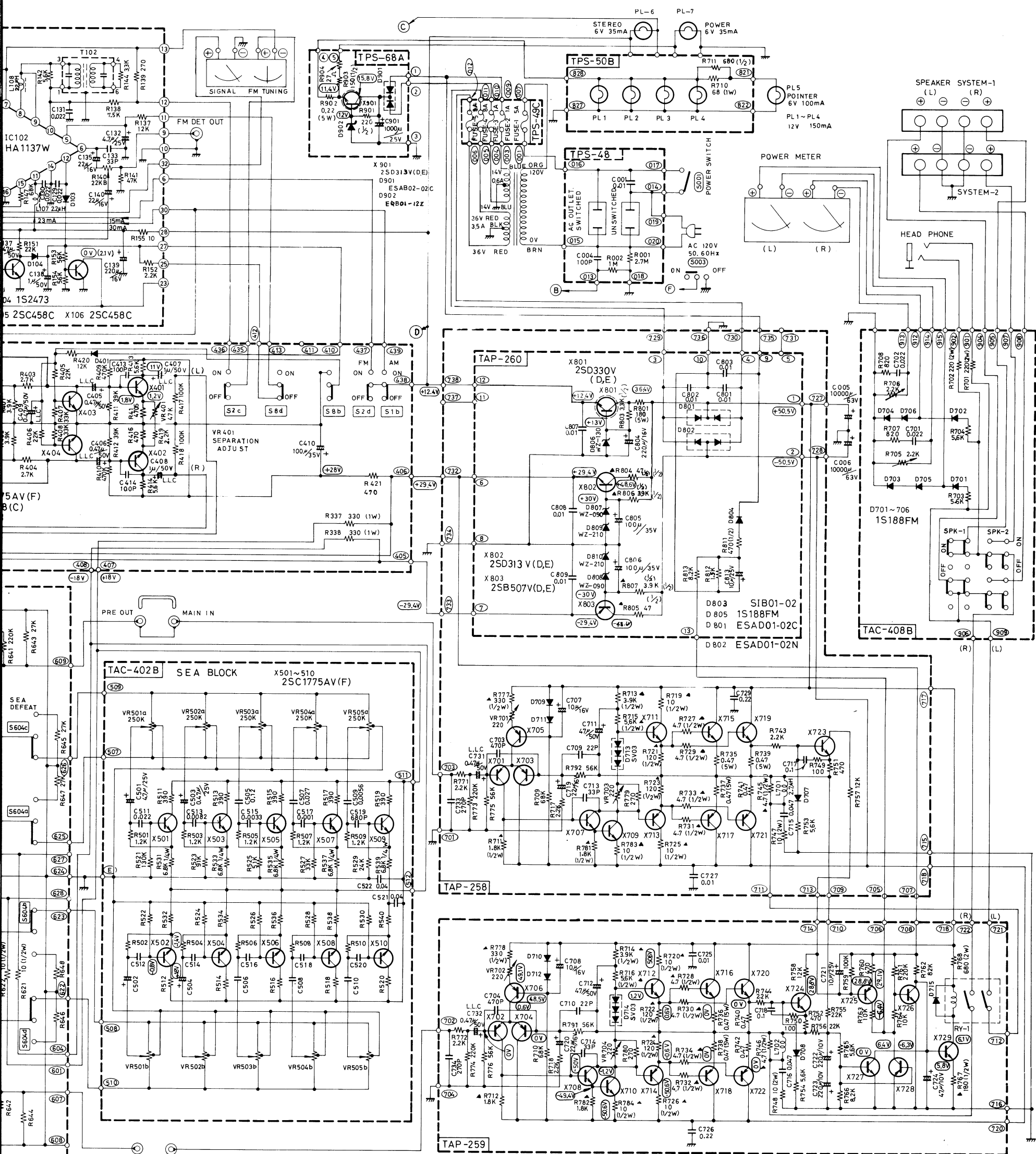

- S1a-b AM
 - S2a-d FM
 - S3a-d PHONO-1
 - S4a-d PHONO-2
 - S5a,b AUX
 - S6a-d TAPE-1
 - S7a-d TAPE-2
 - S8a-d FM MUTING OFF MONO
- SELECT
- S001 POWER SWITCH
 - S002 INT ANTENNA SWITCH
 - S003

- X701-706 2SA872AV (E)
- X707, 708 2SC1775AV (F)
- X709, 710 2SC1628 (O,V)
- X711, 712 2SD381 (L,M)
- X713, 714 2SD536 (L,M)
- X715, 716, 719, 720 2SC898V (B,C)
- X717, 718, 721, 722 2SA753V (B,C)
- X723, 724, 726, 727 2SC1775AV (F)
- X725, 728 2SA872AV (E)
- X729 2SD438 (E)
- D707-712, 715 1S2473

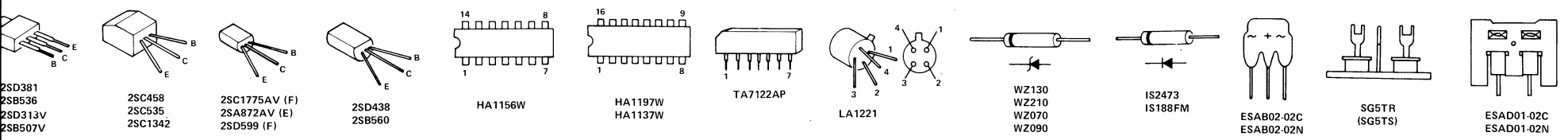

FOR USA (UL)
CANADA (CSA)

AC POWER SUPPLY BLOCK

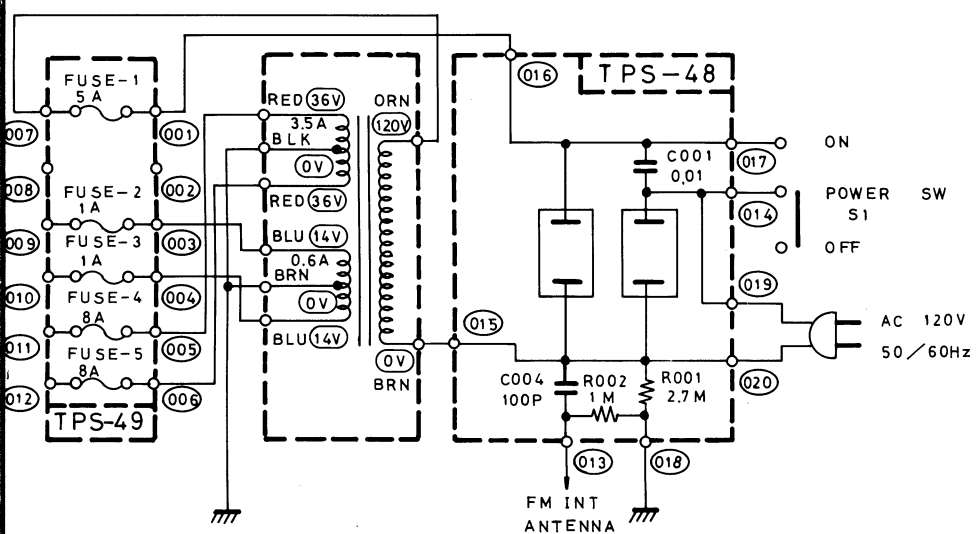

MKO SEV)

ER SW

AC
50/60Hz

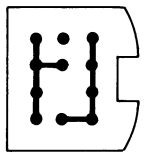

VOLTAGE SELECTOR PLUG

MODEL JR-S400 SERVICE MANUAL

SUPPLEMENT

The listed part numbers have been changed for improvement.
This supplement comparatively draws the difference between original and new part number.
Use this supplement together with original service manual.

1. SPECIFICATIONS AT PAGE 2

	Right	Wrong (Original)
Amplifier Section Total Harmonic Distortion	0.2%	0.3%

5. EXPLODED VIEW AND PARTS LIST

5-(1) Front Panel at page 7

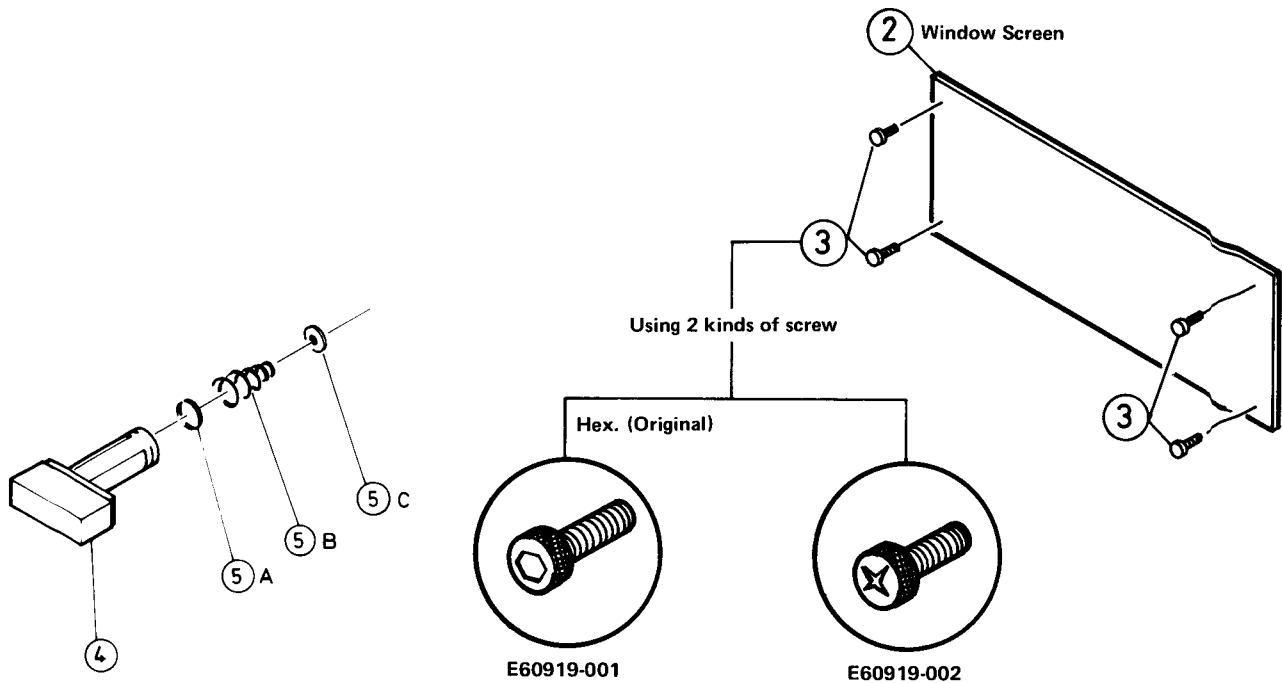

Item No.	New Part Number	Original	New Rating	Description
4	E61240-001	E60859-001		Pushbutton
5	-Delete-	E47794-002		Spring
5A	E47794-002	-Not Listed-		"C" Ring
5B	E60876-001	-Not Listed-		Coil Spring
5C	E61161-001	-Not Listed-		Spacer

8. POWER AMP. ADJUSTMENT PROCEDURES

8-(3) Power Meter at page 14

Correction: 1. Turn R706 and R705 located on TAC-408 fully counterclockwise.
 (Original: R706) (Original: clockwise)

Refer to Fig. 24.

9. CIRCUIT BOARD ASS'Y PART LOCATIONS AND PARTS LIST

9-(5) TAP-258 Power Amp. C.B. Ass'y at page 17

Capacitors

Item No.	New Part Number	Original	New Rating		Description
C713	—See New Rating—	QCS12HJ-330	33pF	500V	Ceramic
C715	—See New Rating—	QFM41HK-473	0.047 μ F	50V	Mylar
C727	—See New Rating—	QCF12HP-103	0.01 μ F	500V	Ceramic
C728	—See New Rating—	QCF12HP-103	"	"	"
C729	—See New Rating—	QFM42AK-224	0.22 μ F	100V	Mylar
C739	QCF12HP-103	—Not Listed—	0.01 μ F	500V	Ceramic
C740	QCF12HP-103	—Not Listed—	"	"	"

Resistors

Item No.	New Part Number	Original	New Rating		Description
R777	QRG129J-221	QRG129J-331	220 Ω	1/2W	Uninflammable O.M.
VR701	QVP4A0B-471	QVP4A0B-221	470 Ω		Variable

Other

Item No.	New Part Number	Original	New Rating	Description
	E22097-001	E22051-001		Heat Sink

9-(6) TAP-259 Power Amp. C.B. Ass'y at page 19

Capacitors

Item No.	New Part Number	Original	New Rating		Description
C714	—See New Rating—	QCS12HJ-330	33pF	500V	Ceramic
C725	—See New Rating—	QCF12HP-103	0.01 μ F	"	"
C726	—See New Rating—	QFM42AK-224	0.22 μ F	100V	Mylar

Resistors

Item No.	New Part Number	Original	New Rating		Description
R778	QRG129J-221	QRG129J-331	220 Ω	1/2W	Uninflammable O.M.
VR702	QVP4A0B-471	QVP4A0B-221	470 Ω		Variable

9-(7) TAP-260 Power Supply C.B. Ass'y at page 22

Diodes

Item No.	New Part Number	Original	New Rating		Description	Maker
D803	—Delete—	SIB01-02			Silicon	Fujitsu
D807	E0771-10	E0771-12	9V		Zener	Fuji
D808	E0771-10	E0771-12	"		"	"

Capacitors

Item No.	New Part Number	Original	New Rating		Description
C801	—See New Rating—	QCF12HP-103	0.01 μ F	500V	Ceramic
C802	—See New Rating—	QCF12HP-103	"	"	"
C805	QEW41VA-107	QEW41HA-476	100 μ F	35V	Electrolytic
C806	QEW41VA-107	QEW41HA-476	"	"	"
C810	—Delete—	QEW40JA-227	(220 μ F)	(6.3V)	"
C811	—Delete—	QEW41CA-476	(47 μ F)	(16V)	"
C812	—Delete—	QEW41EA-226	(22 μ F)	(25V)	"

Resistors

Item No.	New Part Number	Original	New Rating		Description
R803	QRG129J-392	QRG129J-332	3.9k Ω	1/2W	Oxide Metal Film
R806	QRG129J-392	QRG129J-332	"	"	"
R807	QRG129J-392	QRG129J-332	"	"	"
R809	—Delete—	QRD141J-224	(220k Ω)	(1/4W)	Carbon
R810	—Delete—	QRD126J-102	(1k Ω)	(1/2W)	Uninflammable Carbon
R814	—Delete—	QRD126J-181	(180 Ω)	(")	"
R815	—Delete—	QRD126J-150	(15 Ω)	(")	"

9-(9) TAC-406 S.E.A. (Sound Effect Amp.) Amp. C.B. Ass'y at page 26

Capacitors

Item No.	New Part Number	Original	New Rating		Description
C615	—See New Rating—	QZ0046-475	4.7 μ F	50V	N.P. Electrolytic
C616	—See New Rating—	QZ0046-475	"	"	"

Others

Item No.	New Part Number	Original	New Rating	Description
	E03628-7UD	E03628-7		7-pin plug
	E03628-9UD	E03628-9		9-pin plug

9-(10) TAC-408B Speaker C.B. Ass'y at page 29

Diodes

Item No.	New Part Number	Original	New Rating	Description	Maker
D701	1S2473F	1S188FM		Silicon	Sanyo
D702	1S2473F	1S188FM		"	"
D703	1S2473F	1S188FM		"	"
D704	-Delete-	1S188FM		"	"
D705	-Delete-	1S188FM		Germanium	"

Capacitors

Item No.	New Part Number	Original	New Rating		Description
C701	QFM41HJ-332	QFM41HK-223	3300pF	50V	Mylar
C702	QFM41HJ-332	QFM41HK-223	"	"	"

Resistors

Item No.	New Part Number	Original	New Rating		Description
R705	QVP4A0B-472	QVP4A0B-222	4.7k Ω	1/8W	Variable
R706	QVP4A0B-472	QVP4A0B-222	"	"	"
R791	QRD141J-331	-Not Listed-	330 Ω	1/4W	Carbon
R792	QRD141J-331	-Not Listed-	"	"	"

Others

Item No.	New Part Number	Original	New Rating	Description
	E03628-3UD	E03628-3		3-pin plug
	E03628-7UD	E03628-7		7-pin plug

9-(11) TAC-414 Selector C.B. Ass'y at page 30

Capacitors

Item No.	New Part Number	Original	New Rating		Description
C307	QEW40JA-107	QEW41EA-106	100 μ F	6.3V	Electrolytic
C313	QFM41HJ-332	QFM41HJ-272	3300pF	50V	Mylar
C317	-Delete-	QCS11HJ-271	(270pF)	(")	Ceramic
C318	-Delete-	QCS11HJ-271	(")	(")	"

Resistors

Item No.	New Part Number	Original	New Rating		Description
R301	QRD141J-104SL	QRD141J-473SL	100k Ω	1/4W	Carbon
R305	QRD141J-104SL	QRD141J-105SL	"	"	"
R309	QRD141J-334SL	QRD141J-124SL	330k Ω	"	"
R313	QRD141J-561SL	QRD141J-471SL	560 Ω	"	"
R315	QRD141J-683SL	QRD141J-473SL	68k Ω	"	"
R323	QRD141J-104SL	QRD141J-821SL	100k Ω	"	"
R331	QRD141J-394SL	QRD141J-514SL	390k Ω	"	"
R339	QRD141J-332SL	QRD141J-123SL	3.3k Ω	"	"
R345	QRD141J-102SL	-Not Listed-	1k Ω	"	"
R346	QRD141J-102SL	-Not Listed-	"	"	"

9-(12) TFM-910GUA2 FM/AM Tuner C.B. Ass'y at page 33

Integrated Circuits

Item No.	New Part Number	Original	New Rating	Description
IC104	HA1197	HA1197W		I.C.

Coil

Item No.	New Part Number	Original	New Rating	Description
L108	E03522-220J	E03522-180J	22 μ H	FM Detector Coil

Capacitors

Item No.	New Part Number	Original	New Rating		Description
C113	QCT05CG-220	QCT05SG-220	22pF	50V	Ceramic
C182	QCS11HJ-5R0	-Not Listed-	5pF	"	"

Resistors

Item No.	New Part Number	Original	New Rating		Description
R138	QRD181J-752	QRD181J-822	7.5k Ω	1/8W	Carbon
R144	QRD181J-332	-Not Listed-	3.3k Ω	"	"

10. PACKING MATERIALS LIST AT PAGE 38

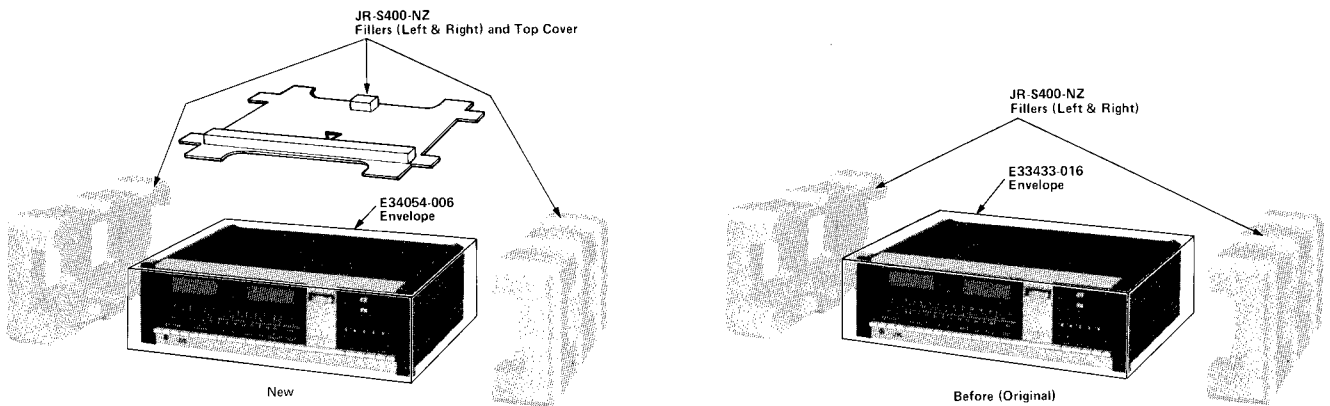

13. PARTS LIST WITH SPECIFIED NUMBERS FOR DESIGNATED AREAS AT PAGE 40

Page	Item No.	Description	Original	For European Countries	For Australia	For Canada	For Other Countries and PACEX
7	28	Power Switch	QSU1135-001	QSP2111-011	QSP2111-011	QSU1135-001	QSU1135-001
		Bracket (Power Switch)	E60860-002	E60860-003	E60860-003	E60860-002	E60860-002
8	10	Power Cord	QMP1200-244	QMP3800-240	E03551-002	QMP1200-244	QMP1200-244
				E03544-001 (SEMCO only)			
8	9	Cord Stopper	QHS3876-162	QHS3876-162	QHS6374-252	QHS3876-162	QHS3876-162
		Fuse (Primary)	QMF61U1-5R0	QMF51A2-3R15	QMF51A2-3R15	QMF61U1-5R0	QMF60R1-6R0
		Fuse (Secondary)					QMF60R1-3R3 (For 220V/240V only)
		8A	QMF61M2-8R0	QMF51A2-8R0	QMF51A2-8R0	QMF60R1-8R0	QMF60R1-8R0
		1A	QMF61U1-1R0	QMF51A2-1R0	QMF51A2-1R0	QMF60R1-1R0	QMF60R1-1R0
6	4	Power Transformer	E03077-22	E03077-22B	E03077-22B	E03077-22	E03077-22B
15	9-(1)	AC Block Ass'y	TPS-48	TPS-64	TPS-64	TPS-48	TPS-48B
15	9-(2)	AC Fuse C.B. Ass'y	TPS-49C	TPS-49D	TPS-49F	TPS-49C	TPS-49C
38	11	Instruction Book	E30580-514A	E30580-514A E30580-515A (German) E30580-516A (French)	E30580-514A	E30580-514A E30580-516A (French)	E30580-514A
38	11	Warranty Card	BT20020C		BT20029	BT20025	BT20014B (PACEX only)

Note: The number in is for New part number, others are same as original.

JVC

VICTOR COMPANY OF JAPAN, LIMITED, TOKYO, JAPAN