

JVC

SERVICE MANUAL

MODEL

KD-2A/B/C/E/J/U

PORTABLE STEREO CASSETTE DECK

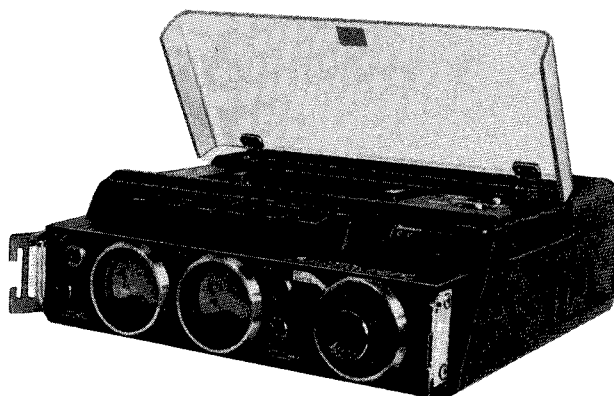

No. 4151
January 1977

Contents

	Page		Page
Specifications	2	Circuit Board Parts	
Features	3	Main Amp Circuit Board Parts List	16
Controls and Connections	3	REC Amp Circuit Board	20
Main parts Location	4	ANRS Circuit Board	22
Main Parts Removing		Mechanical Component (1)	25
Enclosure Assembly	5	Mechanical Component (2)	26
Electrical Parts	6	Mechanical Component List	27
Mechanical Parts	7	Enclosure Ass'y and Electrical Parts	
Main Adjustments		Except Circuit Board Parts (1)	29
Electrical Adjustment	8	Except Circuit Board Parts (2)	30
Mechanical Adjustment	12	Wiring	32
Maintenance	14	Standard Schematic Diagram	33
Block Diagram	15	Accessories	35
		Packing	36

Specifications

Type	: Portable stereo cassette deck	Rewind time	: Less than 90 sec (with the C-60 cassette) per track
Track system	: 4-track, 2-channel	Semiconductors	: IC; 4, Transistor; 37, Diodes; 25, SCR; 1
Cassettes	: C-30, C-60, C-90	Input jacks	: Mic jack; 2 Max. sensitivity; 0.2mV (-72dBs) Matching impedance; 600Ω (200Ω~2kΩ) Input jack; 2 Max. sensitivity; 78mV (-20dBs) Input impedance; 100kΩ
Tape speed	: 4.8cm/sec	Output jacks	: Output jack; 2 Output level; 500mV (fixed) Output impedance; 2.5kΩ Matching impedance; 50kΩ or more Headphone jack; 1 Output level; 0.75mW Matching impedance; 8Ω
Frequency response	: Chrome *1 25~18,000Hz (Nominal) 30~16,000Hz (Typical) Regular *2 25~17,000Hz (Nominal) 30~15,000Hz (Typical) Supasses DIN 45500 *1 TP-18 or Equivalent *2 QP-12 or Equivalent	Recording connector (REC/PB)	: Min. input level; 0.2mV/kΩ Input impedance; 2.2kΩ Output level; 500mV Output impedance; 2.5kΩ Matching load impedance; 50kΩ or more
Signal-to-Noise ratio	: 57dB (from peak level, weighted) The S/N is improved by 5dB at 1kHz and by 10dB above 5kHz with ANRS on. 62dB with ANRS (DIN 45500, weighted)	Power supply	: DC 6V ("D" size CELL x 4) External DC power; 6V AC power; 120V, 60Hz for KD-2J/C 120/220/240V, 50Hz for KD-2A/B/E 100V, 115V 230V 50/60Hz for KD-2U
Effect of Super ANRS (Normal tape)		Power consumption	: 5.5W (KD-2J/C) 6W (KD-2A/B/E/U)
Improvement of Signal-to-Noise ratio	: the same as with ANRS	Battery life	: Approx. 6 hours of continuous recording (on super type batteries)
Improvement of frequency response	: 0VU recording; 6dB at 10kHz +5VU recording; 12dB at 10kHz	Dimensions	: 10-7/8 (width) x 3-3/4 (height) x 11-3/8 (depth) in.
Improvement of distortion	: 0VU recording; 3% or less at 10kHz +5dB recording; 3% or less at 10kHz	Weight	: 8.8 lbs. (including 4 batteries)
Wow and flutter	: 0.09% (WRMS) 0.20% (DIN 45511)	Design and specifications are subject to change without notice.	
Separation	: 35dB		
Harmonic distortion	: 1.2% (Normal tape 1kHz, 0VU)		
Bias	: AC bias (95kHz)		
Erase	: AC erase		
Heads	: 2 heads SA head for recording/playback and ferrite head for erase		
Motor	: DC coreless motor		
Recording time	: 2 x 30 minutes with the C-60 cassette		
Fast Forward time	: Less than 90 sec (with the C-60 cassette)		

Features

- ★ Compact and feather portable type.
- ★ Power-saving design.
- ★ Coreless motor.
- ★ Built-in ANRS and Super ANRS.
- ★ Sen-alloy head.
- ★ Full auto stop.
- ★ Dual ball cassette holder
- ★ Automatic selector of stereo/mono for MIC record.
- ★ Built-in headphone volume.
- ★ Input select switch

Controls and Connections

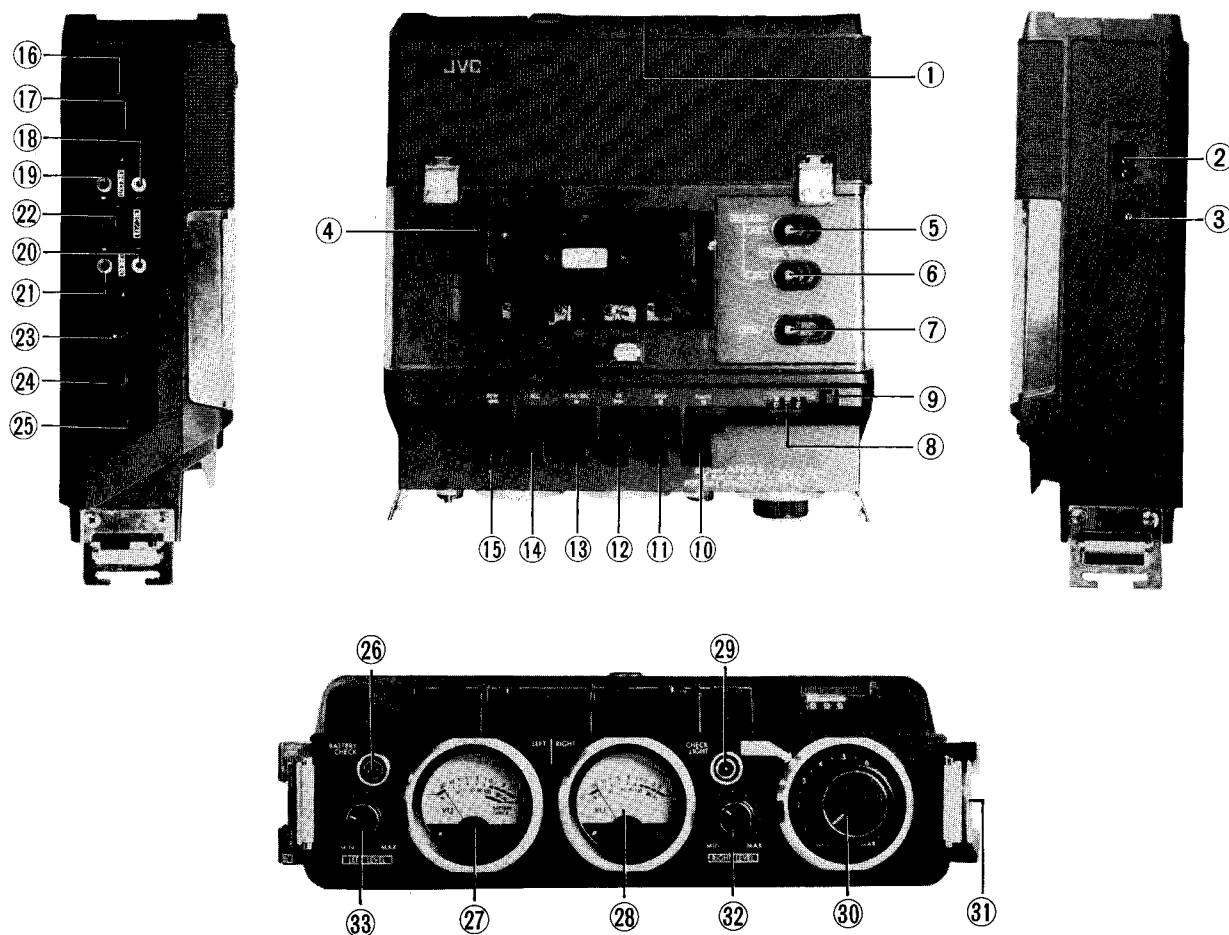

Fig. 1

- | | |
|-----------------------------------|--|
| 1. Battery holder | 18. Left auxiliary output jack [LINE OUT-L] |
| 2. AC socket | 19. Right auxiliary output jack [LINE OUT-R] |
| 3. DC Input jack (DC 6V) | 20. Left auxiliary input jack [LINE IN-L] |
| 4. Cassette cover | 21. Right auxiliary input jack [LINE IN-R] |
| 5. Bias switch [BIAS] | 22. DIN socket [REC/PB] |
| 6. Equalizer switch [EQ] | 23. Input select switch [INPUT SELECT] |
| 7. ANRS switch | 24. Left microphone jack [MIC-LEFT] |
| 8. Tape counter | 25. Right microphone jack [MIC-RIGHT] |
| 9. Counter reset button | 26. Battery check button [BATT CHECK] |
| 10. Pause button [PAUSE ■■] | 27. Left VU meter |
| 11. Stop button [STOP ■] | 28. Right VU meter |
| 12. Fast forward button [FF ►►] | 29. VU meter check light SW [CHECK LIGHT] |
| 13. Play back button [PLAY/REC ►] | 30. REC master volume [REC MASTER] |
| 14. Record button [REC] | 31. Metal for shoulder strap. |
| 15. Rewind button [REW ◀◀] | 32. Right Record level [RIGHT LEVEL] |
| 16. Headphone jack [PHONES] | 33. Left Record level [LEFT LEVEL] |
| 17. Headphone volume | |

Main Parts Location

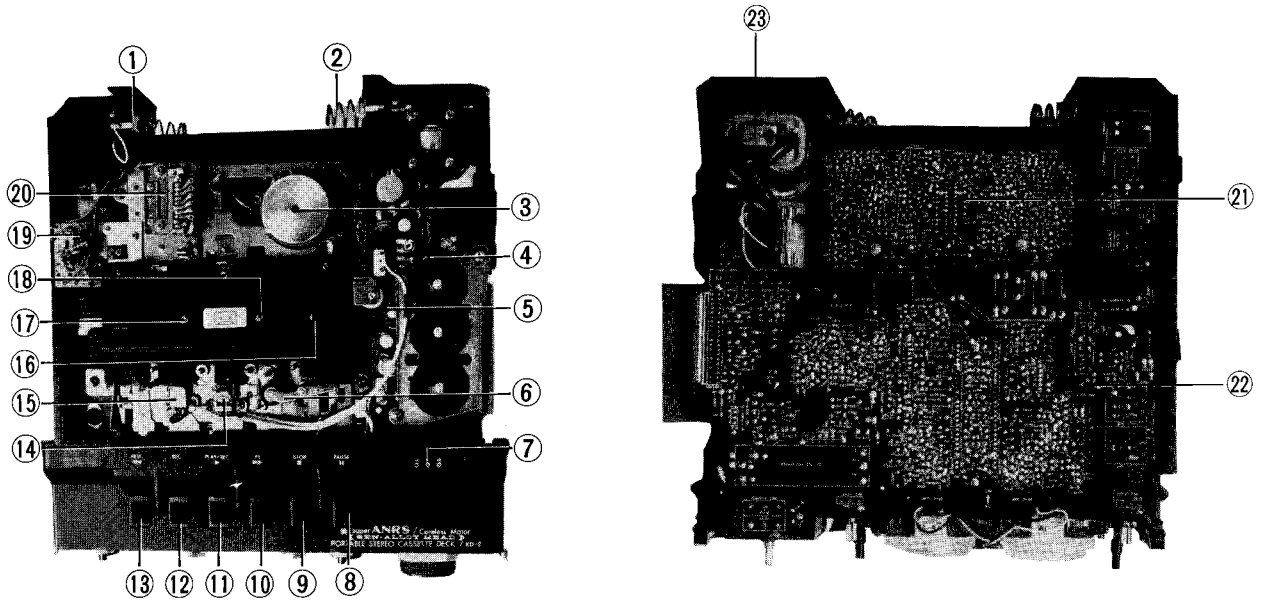

Fig. 2

1. Battery contact (+)
2. Battery contact ass'y (-)
3. Motor ass'y
4. REC. AMP circuit board
5. Magnet pulley ass'y
6. Pinch roller arm ass'y
7. Counter ass'y
8. Push button (Pause)
9. Push button (Stop)
10. Push button (FF)
11. Push button (Playback)
12. Push button (Record)
13. Push button (Rewind)

14. R/P head
15. Erase head
16. Steel ball
17. Supply disc ass'y
18. Take up disc ass'y
19. Motor circuit board
20. Muting circuit board
21. ANRS circuit board
22. Main amp circuit board
23. Power transformer

Note; The circuit board assemblies and cassette mechanism in this model will not be available as spare parts.

Main Parts Removing

This cassette deck which features a compact design and performance uses miniatures sized parts which are closely arranged.

Enclosure Assembly

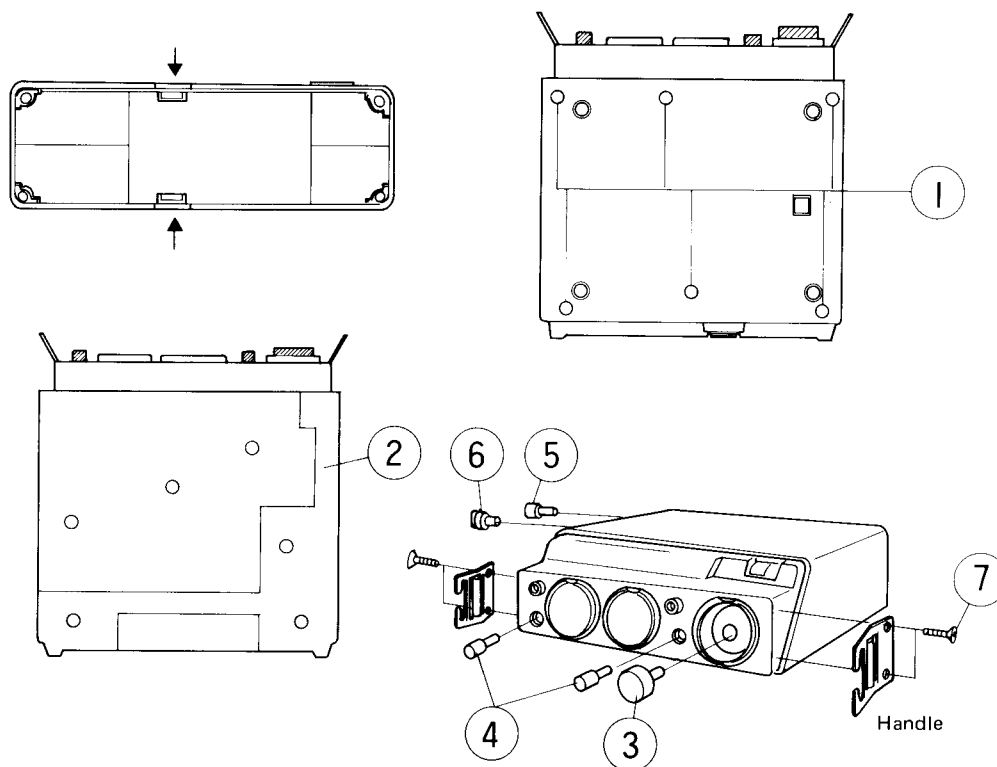

Fig. 3

Enclosure assembly

Parts name	Procedure	Ref. No.	Remarks
Battery cover	Push the battery cover the direction of arrow in illustration and remove it to back.		
Bottom cover	Remove 5 screws (3φ 12mm) and 1 screw (3φ 14mm) fastening the bottom cover.	①	When remove the bottom cover, can be adjusted the semi-fixed resistors on the main amp circuit board.
Top panel	1. Remove the bottom covers 2. Remove 5 screws fastening the top panel. 3. Remove to pull out the left side of the top panel and to open in front of the front panel by your fingers.	②	Screws 5 p.c.s = 3φ, 10mm (blue) When replace the top panel, do as same as (3)
Knobs	Pull off Master knob..... 1 p.c Record level knobs 2 p.c.s Headphone volume knob 1 p.c. MIC/DIN input select knob... 1 p.c.	③ ④ ⑤ ⑥	
Front panel	1. Remove the bottom cover and the top panel 2. Remove 4 screws fastening the handles 3. Pull off in front the master knob and the Record level knobs 4. Pull off in front the front panel.	③ ④	Screws 4 p.c.s = 3φ, 16mm When replace the VU meter and the pilot lamp, must be removed the front panel.

Electrical Parts

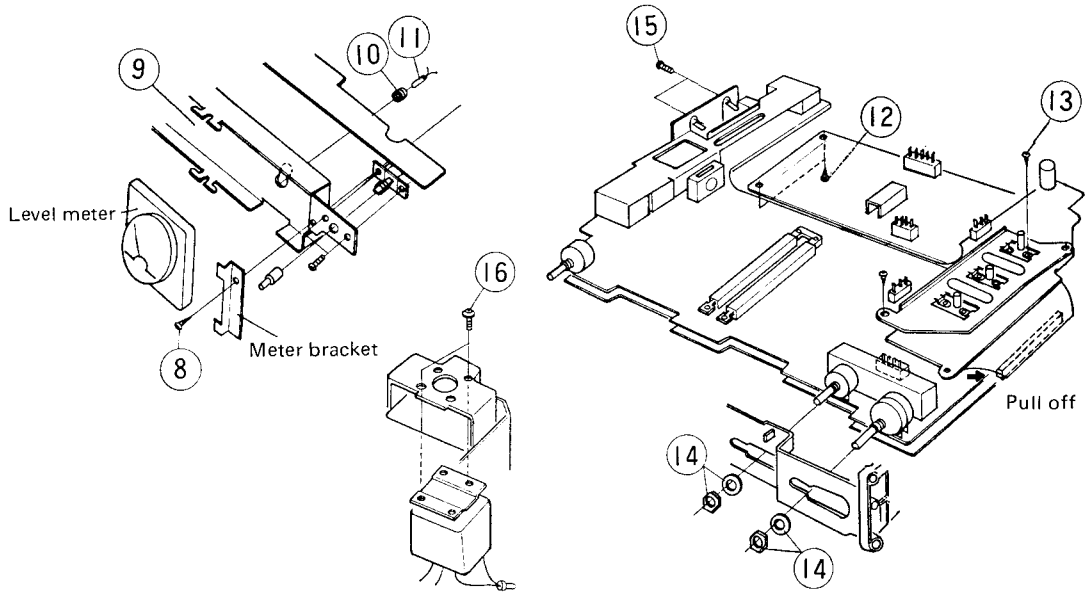

Fig. 4

Electrical parts

Parts name	Procedure	Ref. No.	Remarks
VU meters	<ol style="list-style-type: none"> 1. Remove the front panel. 2. Remove 2 screws fastening the meter bracket. 	⑧	Tapping screws = 3φ, 8mm
Pilot lamp	<ol style="list-style-type: none"> 1. Remove the front panel and the VU meter 2. Remove the push switches bracket. 3. Remove the bushing of the pilot lamp from the push switches bracket. 4. Remove the pilot lamp from the bushing 	⑨ ⑩ ⑪	
ANRS circuit board	<ol style="list-style-type: none"> 1. Remove 2 screws fastening the ANRS circuit board. 2. Pull off the left side it's board. 	⑫	Tapping screws = 3φ, 8mm (violet)
REC amp circuit board	<ol style="list-style-type: none"> 1. Remove 2 screws fastening the lever switch bracket. 2. Pull out the connector from main amp C. board to direction of the arrow in illustration. 	⑬	Screws = 2.6φ, 4mm (violet) Be carefull to pull off the connector, slowly and holding the both sides of it. (Because it may be broken which the plate is wide)
Main amp circuit board	<ol style="list-style-type: none"> 1. Remove washers and nuts of the variable resistors. (master volume and 2 REC volumes.) 2. Remove 2 screws fastening the PIN jack circuit board (left side of it) 3. Remove 2 screws fastening the shield board at bottom. 	⑭ ⑮	Remove the main amp circuit board, after disconnecting the F.P.C.
Power transformer	Remove 2 screws fastening the power transformer	⑯	Screws = 3φ, 8mm

Mechanical Parts

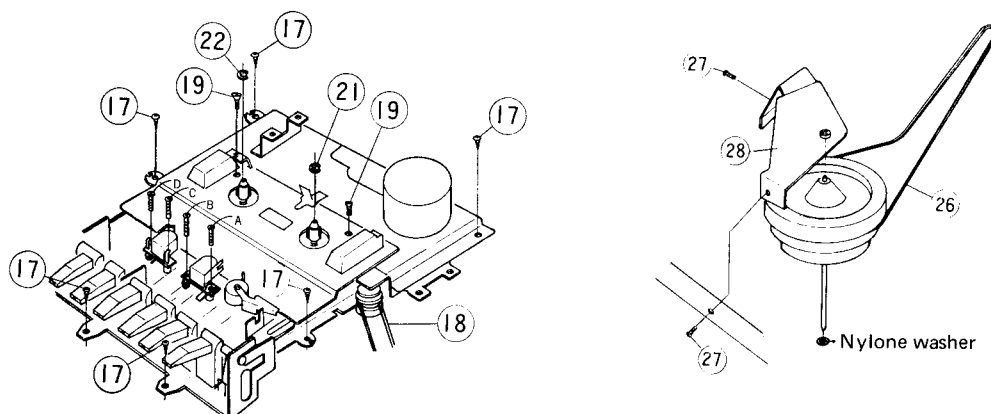

Fig. 5

Mechanical parts

Parts name	Procedure	Ref. No.	Remarks
Mechanical ass'y	<ol style="list-style-type: none"> 1. Remove 6 screws fastening the mechanical ass'y. 2. Remove the counter belt. 3. Remove the connecting wires of heads, etc. 	<p>(17)</p> <p>(18)</p>	Tapping screws = 3φ, 10mm
Cassette holder	Remove 2 screws fastening the cassette holder	(19)	
Motor	<ol style="list-style-type: none"> 1. Remove 2 screws fastening the shield plate 2. Remove the capstan belt. 3. Remove 3 screws and 3 washers fastening the motor. 4. Remove 2 screws fastening the motor circuit board. 5. Disconnect the wires of motor circuit board. 		<ol style="list-style-type: none"> 1. When replace the motor, replace it's circuit board as same. (because motor and it's circuit board are pair parts for adjustment.) 2. Be careful not to stain the capstan belt.
Flywheel	<ol style="list-style-type: none"> 1. Remove 2 screws fastening the flywheel Holder. 2. Remove the flywheel holder from the mechanical chassis. 3. Remove the capstan belt. 4. Pull out the flywheel. 	<p>(27)</p> <p>(28)</p> <p>(26)</p>	When replace the flywheel, don't forget to insert a nylon washer to it's shaft.
Pinch roller arm ass'y	<ol style="list-style-type: none"> 1. Remove "E" ring holding the pinch roller arm ass'y. 2. Remove spring on the arm ass'y. 		
Take up disc	<ol style="list-style-type: none"> 1. Remove the cassette holder 2. Remove the counter belt 3. Remove "E" ring holding the take up disc. 4. Pull off the disc from the shaft. 	(21)	
Supply disc	<ol style="list-style-type: none"> 1. Remove the cassette holder 2. Remove "E" ring holding the supply disc. 3. Pull off the disc from the shaft. 	(22)	

Note;

1. Don't dirty, slippy and undue run-out the capstan belt and counter belt.
2. Adjust height of the motor pulley, when the capstan belt connect to the flywheel from the motor pulley, so that it will be parallel to the chassis.
3. When remove the screw (19), use the machining driver to the screw top groove.

Main Adjustments

Electrical Adjustment

Equipment and measuring instruments used for adjustment.

1. V.T.V.M. (measuring AC in millivolt)
2. Audio-frequency oscillator (range: 50–20kHz and output 0dBs with impedance 600Ω)
3. Attenuator (600Ω)
4. Reference tapes for REC/PB
 TS-1 (QP-12, C521V) – normal tape
 TS-2 (TP-18, C402R) – chrome tape
5. Reference tapes for playback
 VTT-658 (for head azimuth)
 VTT-656 (for tape speed & wow flutter)
 VTT-664 (1kHz reference level)
 VTT-675N (for playback frequency response)
6. Resistors
 100Ω (for measurement of the bias current)
 600Ω (for attenuator matching)
7. Distortion Meter, Band pass filter

When you adjust following items, we recommend to you to keep doing step No.

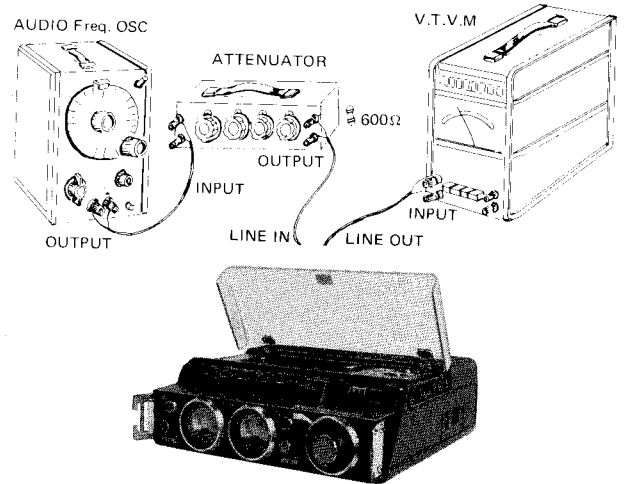

Fig. 6

1. Electrical Adjustment Playback

No.	Item	Procedure	Part	Rating	Remarks
1.	Level meter deflection	1. Set the deck to the record mode. 2. Input 1kHz signal (about 10dBs) from LINE IN jacks. 3. Adjust the REC volume so that LINE OUT become 3.5dBs. 4. Adjust R148 and R248 in this condition it obtain zero VU meter reading	Main amp circuit board R148, 248 (METER)	VU meter range; 0	The angle of meter deflection has been factory-adjusted, but should be adjusted when parts are replaced.
2.	Playback sensitivity	1. Set equalizer switch at "NORMAL" position and turn off ANRS switch. 2. Adjust R126 and R226 so that level meters indicate zero VU using reference tape VTT-664 (1kHz)	Main amp circuit board R126, 226 (P.B LEVEL)	VU meter range; 0	1. Should be adjusted playback sensitivity when heads are replaced. 2. Make this adjustment after making sure level meter deflection angle is correct.
3.	Check of PB frequency response	Playback the reference tape VTT-675N (1kHz) and check the OUTPUT level of each frequency to become the rating.		Rating Reference frequency; 1kHz Normal 63Hz +2dB±3dB 10kHz 0 ±3dB Chrome 63Hz +2dB±3dB 10kHz -4dB±3dB	1. When use reference tape VTT-675, it's level over about 3~4 dB at 63Hz compared with 1kHz. 2. When check at chrome it's level, set the equalizer switch at "NORMAL" position to compared with 1kHz.

Record/playback

TS-1 use at normal mode and TS-2 use at chrome mode.

No.	Item	Procedure	Rating	Remarks
1.	Check of REC/PB frequency response	Input 1kHz (0VU–20dB) signal from LINE IN make recording the blank tape, and then record 50Hz, 10kHz signals. When it's tape playback, 50Hz or 10kHz output level become in rating at comparison 1KHz output level as the reference frequency. (As basic thought, 1KHz, 50Hz and 10KHz output level become the flat frequency response as same.)	Reference frequency; 1kHz Normal 50Hz 0±3dB 10kHz 0±3dB Chrome 50Hz 0±3dB 10kHz 0±3dB	Do adjust normal and chrome, L channel and R channel.

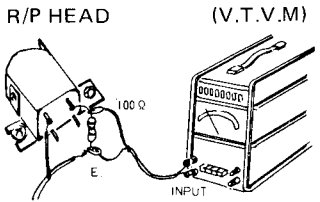
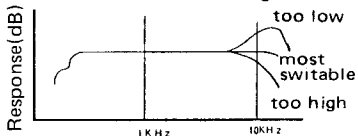
Item	Procedure	Part	Rating	Remarks
2. Bias current	Input 1kHz and 10kHz (OVU-20dB) signals from LINE IN to record in reference tape. When playback it's tape, adjust R R514, 614 (normal) and R513, 613 (chrome) so that OUT PUT levels become equal values. R/P HEAD (V.T.V.M) 	Rec amp circuit board Normal R514, 614 (BIAS) Chrome (BIAS)		<ol style="list-style-type: none"> Standard method for bias adjustment of cassette deck are adjusted the frequency response at REC/PB. Because the cassette tape is great affection to bias current of frequency response than open-reel tape. When you measure the bias current, can you doing the easy way as below. If not correct the bias current, frequency responses are shown as the next figure. 
	[Easy method] <ol style="list-style-type: none"> Set the deck to record mode. Connect a 100Ω resistor to the ground side (at record mode) of the head wire. Measure it's voltage. 		Normal 33mV Chrome 53mV	<ol style="list-style-type: none"> If the meter pointer moving at PB mode when your finger touch a head wire, it's wire is ground side at Rec mode (Because the head wire of 2 head deck become opposite polarity at playback and at record.) Must use the shield wire.
3. REC/PB level	<ol style="list-style-type: none"> Input 1kHz (-10dBs) signal from LINE IN, adjust the REC master volume so that LINE OUT level become -8dBs. Make recording in such a way that the level meters indicate zero VU at normal mode or chrome mode (as same Left channel or right channel) Playback it and adjust the semi-fixed resistors for REC level so that the level meters indicate zero VU. 	Main amp circuit board Normal [R149, 249 REC LEVEL] Chrome [R150, 250 REC LEVEL]	OVU	The difference in level of each channel is less than 1dB.
4. Check of REC/PB distortion	<ol style="list-style-type: none"> Input 1kHz (-10dBs) signal from LINE IN, and make recording in such a way that the level meters indicate zero VU. Playback and check it that the distortion become rating less. 		Normal 3% less Chrome 4% less	Make this adjustment after making sure bias current, and REC level.
5. Check of REC/PB signal to noise ratio.	<ol style="list-style-type: none"> Input 1kHz OVU signal from MIC IN, make recording that the level meters indicate zero VU, and then make recording at no signal mode. Playback it's tape and measure the signal to noise ratio by V.T.V.M. 		Normal 42dB or more Chrome 42dB or more	REC volume at maximum.
6. Check of erasure ratio	<ol style="list-style-type: none"> Input and make recording as same 5. Continue recording to up 20dB the signal level. Rewind it's tape and erase the part of it. Measure output level to the recording part ratio the erasing part. 		60dB or more	When measure the erasing ratio, connect the B.P.F (Band pass filter) to the deck from the V.T.V.M. (milivolts)

Item	Procedure	Part	Rating	Remarks
7. ANRS circuit	<ol style="list-style-type: none"> 1. Disconnect the soldering position BIAS CUT of main circuit board so that oscillator does not operate. 2. Set the deck to the record mode. 3. Input 1kHz -10dBs signal from LINE IN, Adjust the REC volume so that LINE OUT become -0.5dBs. (not move the REC volume position to finished adjustment.) 4. Turn R335, 435 (CONT GAIN) and R340, 440 (DC BIAS) in the direction opposite to the arrow marking in the shield board. 5. Adjust R324 and R424 so that level does not change when ANRS switch is turned on and off, and turn on ANRS. 6. Input 1kHz -50dBs signal from LINE IN, Adjust R350 and 440 so that LINE OUT become -35dBs. 7. Input 5kHz -30dBs signal from LINE IN Adjust R335, 435 so that LINE OUT become 17dB. 8. Repeat step (5) through (7). 9. Turn ANRS switch in "Super" position when input 10kHz -10dBs signal from LINE IN. Check out put levels are -6.5dBs±2dB. 10. Connect the position BIAS CUT of disconnected in step (1) 11. Playback reference tape VTT-664 and Adjust R302 and R402 so that level does not change when ANRS is turned on and off. 	<p>ANRS circuit board</p> <p>R324, 424 (REC GAIN)</p> <p>R340, 440 (DC BIAS)</p> <p>R335, 435 (CONT GAIN)</p> <p>R302, 402 (PB GAIN)</p>		

Other adjustments

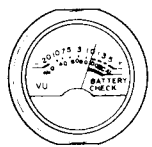
Item	Procedure	Part	Rating	Remarks
1. Battery checker	<ol style="list-style-type: none"> 1. Apply exactly DC3.8V to external DC jack or battery contacts and switch the deck to playback or fast forward mode. 2. Push battery check switch in "CHECK" position and adjust so that meter pointer deflects to the end of green area. 			<p>Do not mistake one polarity for the other.</p> 
2. Check of power consumption	<p>Apply exactly DC 6.0V to external DC jack or battery contacts and switch the deck to playback or record mode.</p> <p>Measure the consumption current as a such way by miliampere meter.</p>	<p>Playback 200mA or less Record 300mA or less</p>	<p>(Standard) 165mV (Standard) 240mA</p>	<p>Pilot lamp at OFF no signal Do not insert cassette tape</p>

Adjustments position location

This deck can be adjusted to remove only the bottom cover.

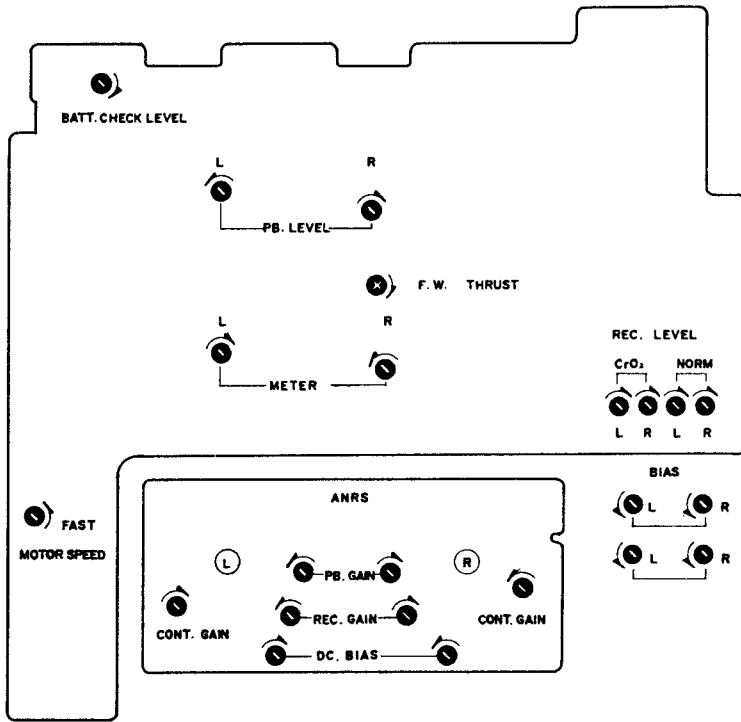

Direction of arrow marks

BIAS=bias current increase

ANRS=ANRS signal level up

PB LEVEL } = level up
REC LEVEL }

METER } = deflection increase
BATT. CHECK LEVEL }

MOTOR SPEED = speed up

F.W. THRUST = clearance narrow

(Look with a bond, after adjust the F.W. THRUST)

Fig. 7

Repair of electrical parts

1. Flexible printed circuit board

This model is used the flexible p.c. board to connection the circuit board.

Because it is easy repair for servicing and easy production for factory.

It have good quality for hardy or other condition, but be careful following items.

- (1) As it's board increase the humidity compare with normal circuit board, after place it in high humidity, if do you solder it that may be broken the print.
- (2) If do you scratch it by cutter etc., may be broken it. (If not scratch, it is very hardy board.)
- (3) Do not fold with sharp angle (an acute angle)
- (4) Don't solder on the flexible area. (If solder, it may be broken near soldering position as illustration.)

If you repair to broken the pattern on F.P.C. board, connect to solder with wire between the circuit board(1) and circuit board(2).

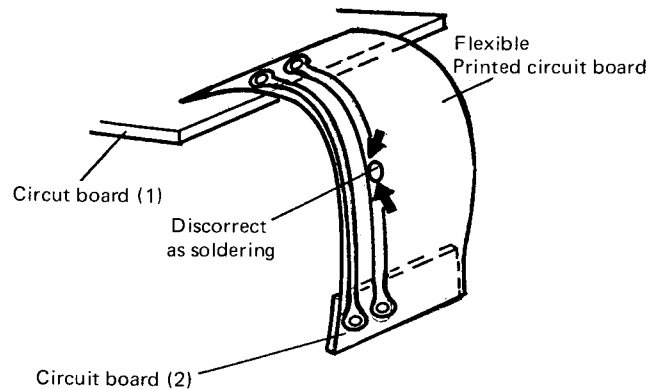
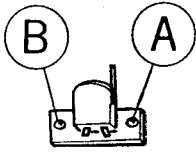
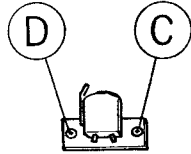
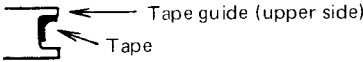
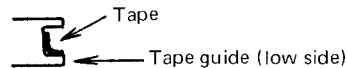

Fig. 8

- 2. For other electrical failures, check the unit in the same manner as other cassette decks.

Mechanical Adjustment

Item	Procedure	Part	Rating	Remarks
REC/PB head azimuth inclination 	<ol style="list-style-type: none"> 1. Connect the milivolt meter to LINE OUT jacks. (or REC/PB socket) 2. Playback the reference tape VTT-658 (10kHz). 3. Turn the screw B so that milivolt meter indicate maximum (output level become max.) 4. After adjustment, the screw B should be locked with a bond. 	Screw B	Max.	<ol style="list-style-type: none"> 1. If either of the REC/PB head show low performance because of wear, broken wire or excessive magnetization, it should be replaced, and then you must adjust the head azimuth, playback sensitivity, REC bias current, and REC/PB level (see electrical adjustment.) 2. If L and R channel levels of head become unbalance 3~4 dB or more, you should be replaced the head.
Height of E head 	Playback the test tape C-120 (front cutted cassette) and turn the screw D so that the tape may run in the center of the guide. <ol style="list-style-type: none"> 1. If the tape touch the upper guide, loose the screw D  2. If the tape touch the low guide, fasten the screw D  After adjustment, the screw D should be locked with a bond.			When replace the E head, must be adjusted this method.
Head position check	Check the head position by the gaze. The clearance is 0.7mm or less between the head and the gaze.		0.7 mm or less	<ol style="list-style-type: none"> 1. Check with your own eyes. 2. If not, high frequency range or erase ratio will be down.
Motor speed	<ol style="list-style-type: none"> 1. Connect the counter meter to the LINE OUT jacks. 2. Playback reference tape VTT-656 (3000Hz). 3. Adjust the semi-fixed resistor on the motor circuit board so that the speed is 3000Hz±2% 		3000Hz ±2% (2940~3060Hz)	<ol style="list-style-type: none"> 1. Motor current is 100mA at playback. 2. If the wow flutter meter built-in the counter meter, connect it's INPUT jacks.
Take-up torque	Measure by the torque measure cassette or the torque gaze tool at the playback mode.		40~60 gr-cm	(If not) <ol style="list-style-type: none"> 1. Clean the main belt, rubber rim of idler and rubber rim of the Take up disc. 2. Replace the idler arm of the take-up and spring.
Fast forward torque	Measure as same way at FF mode.		70 gr-cm or more	(If not) <ol style="list-style-type: none"> 1. Clean the main belt, rubber rim of the idler, motor pulley rim of the flywheel. 2. Replace the main belt, idler, and reel disc ass'y.

Item	Procedure	Part	Rating	Remarks
REW torque	Measure as same way at REW mode.		70 gr-cm or more	(If not) 1. Clean the main belt, idler and rubber rim of it, and motor pulley, rim of the flywheel 2. Replace the reel disc.
Auto-stop mechanism	Loosen 2 screws fastening the solenoid and move it position for adjustment.			Check if the locking and sliding parts of the operation button cam are well coated with molybdenum.

Repair of Wow Flutter

If wow and flutter increase, check the following points.

If there is defect in revolving parts, the wow and flutter generated will increase in proportion to the number of revolutions.

Play a 3000Hz test tape, and defective part can be detected from the sound.

Section	Trouble	Repair
Capstan and flywheel	Capstan shaft has excessive run-out. Flywheel turns heavily. (shaft seizure, thrust play, etc.)	Replace flywheel. Clean the capstan shaft and the groove in the flywheel. Apply oil to the metal position. Replace the capstan assembly.
Pinch roller	Rough rotation (Deformation scratches, or dust). The angular position of the pinch roller is not correct. The pinch roller pressure is not correct.	Replace pinch roller, or pinch roller spring. Clean the pinch roller or apply oil to the rotary shaft. Adjust the pinch roller so that it is parallel with the capstan shaft. Replace the pinch roller spring.
Belt	Belt has undue run-out. Belt is dirty or slippery.	Clean the belt. Replace the belt.
Back tension	Back tension is irregular, or back tension is too strong.	Replace back tension spring (under supply disc).
Motor	Motor shaft has undue run-out. Motor pulley is oily and dusty.	Replace motor. Clean motor pulley.
Take-up idler arm	Pulley has deflection. Pulley is stuck.	Replace take-up idler arm.

Maintenance

To get long, trouble-free service, maintenance is important. Do not forget cleaning and demagnetizing.

Cleaning

After long use, the heads and tape part — capstan, pinch roller, etc. — will become dirty with dust or magnetic particles. Dirty heads cause imperfect erasing or high frequency drop-off. A dirty capstan and pinch roller will cause unstable tape speed, leading to increased wow and flutter. Always keep them clean by following the procedure below.

1. Heads

- 1) Press the PLAY button to move the heads out.
- 2) Use the head cleaning stick provided to wipe the surface where the tape comes into contact with the head.
(It is effective to moisten the cotton with alcohol.)

2. Pinch roller and capstan

- 1) Press the PLAY button, and the pinch roller will move out and rotate.
- 2) Apply a soft cloth (soaked in alcohol, it will be more effective) to the rotating pinch roller and capstan.
Be careful not to let the cloth get caught!
* Do not use any cleaner besides alcohol or a specifically prepared tape head cleaning solution.

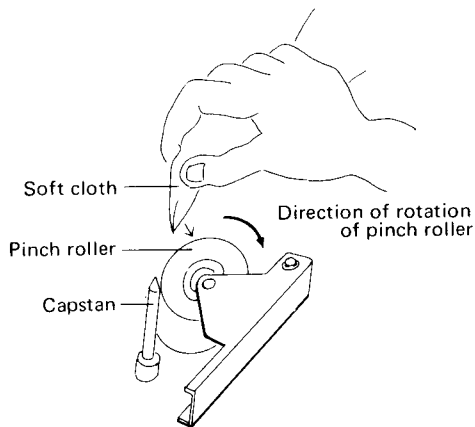

Fig. 9

3. Cabinet

When the cabinet becomes dirty, wipe it with a soft cloth soaked with a neutral cleaning solution of a polishing cloth.

- * Do not use thinner or benzene.

Demagnetizing

The heads are made from a material resistant to magnetization, but after long use they may become magnetized. A magnet brought into their vicinity can magnetize the heads, causing excess noise. If noise seems to have increased, demagnetize the heads with a head demagnetizer through the following procedure.

1. Turn the POWER switch OFF.
2. Wrap the tip of the demagnetizer with vinyl tape or soft cloth so as not to damage the head surface. Switch on the demagnetizer and bring it close to the head.
3. Move the tip of the demagnetizer slowly first to the left and right, then up and down in front of the head. Gradually move it away from the head and switch it off at a distance of more than 30cm. (12")
4. The erase head need not be demagnetized. The capstan shaft and tape guide should be demagnetized in the same way as the record/playback head.
* Do not bring a magnetized metallic object (a screwdriver, for example) near the head as this will increase noise.

Oiling

Feed one or two drops of machine oil to the rewind roller shaft, pinch roller shaft and magnet pulley shaft once or twice a year under normal conditions of use.

Avoid oiling them excessively, or rotation may become irregular because of oil splashes.

Block Diagram

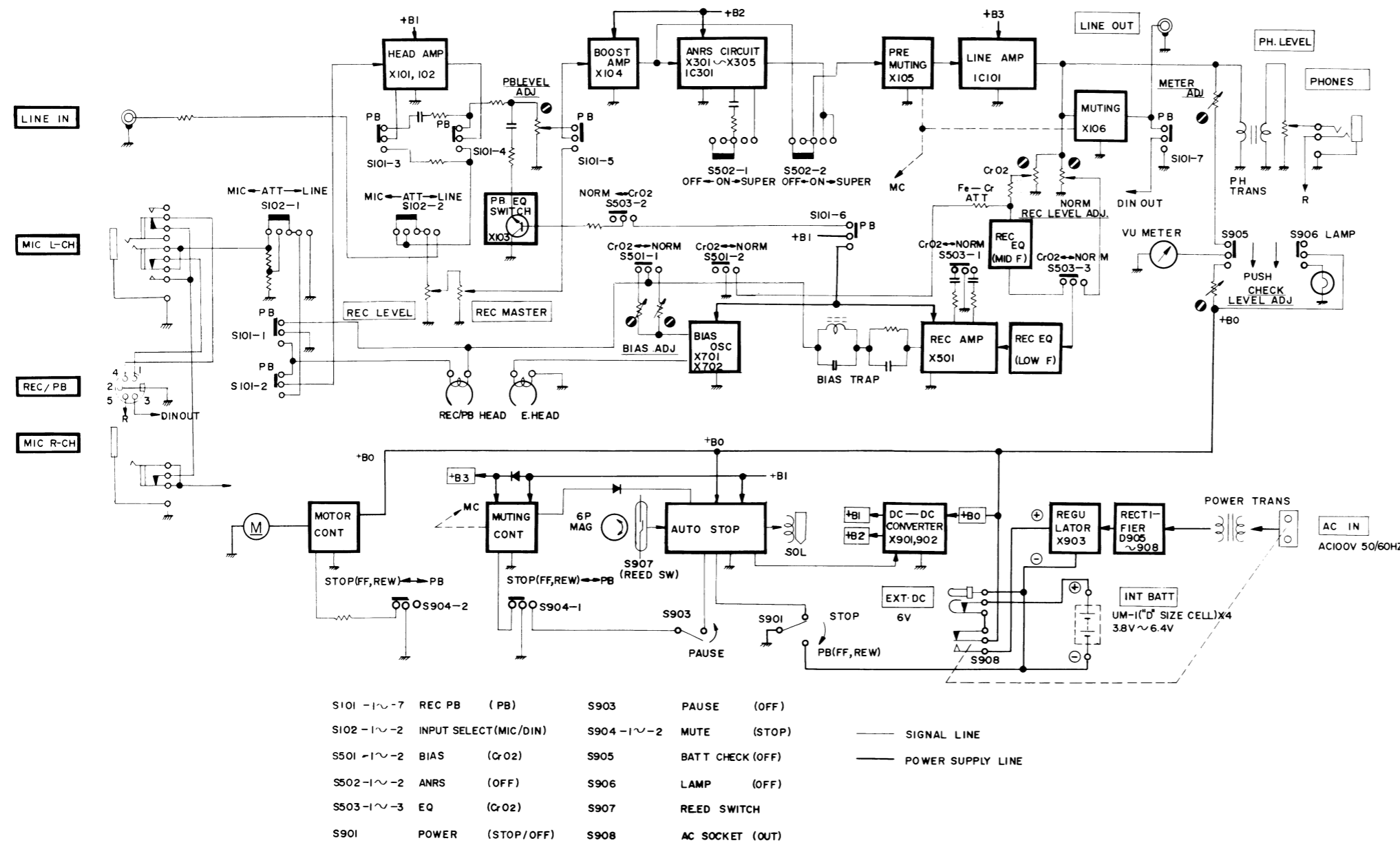

S101-1~7	REC PB (PB)	S903	PAUSE (OFF)
S102-1~2	INPUT SELECT (MIC/DIN)	S904-1~2	MUTE (STOP)
S501-1~2	BIAS (CrO2)	S905	BATT CHECK (OFF)
S502-1~2	ANRS (OFF)	S906	LAMP (OFF)
S503-1~3	EQ (CrO2)	S907	REED SWITCH
S901	POWER (STOP/OFF)	S908	AC SOCKET (OUT)

— SIGNAL LINE
 - - - POWER SUPPLY LINE

TA7066P Equivalent Circuit

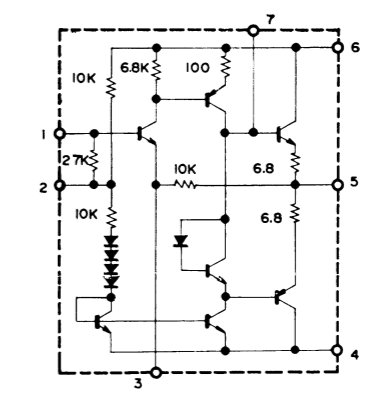

Rotary Switch (S 102, 202) (Bottom-view)

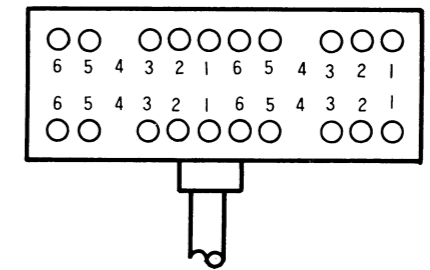

CONNECTION

⑥ ⑤ ④ ③ ② ①
 (MIC/DIN POSITION)
 1 : Free
 4 : No Terminal



2SF656



2SA721
 2SC1327
 2SC828
 2SC828A
 2SC564A
 2SD545

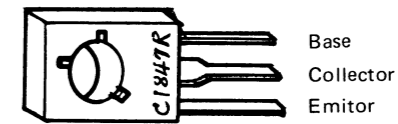

2SC1847

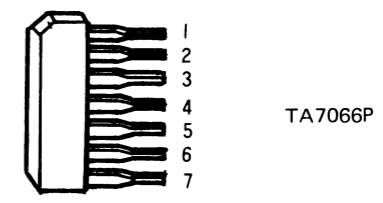

TA7066P

Fig. 10

Main Amp Circuit Board Parts List

Ref. No.	Part No.	Part Name	Remarks	Q'ty
	*TAA336105-02	Circuit Board	Not supplied as parts Ass'y	1
	QSS9201-001	Slide Switch		2
	*TAS350402-01	Shield Plate		1
	*TFB336401-01	Switch Connector		1
	SPSP2006Z	Screw		2
R _{121,221} R _{120,220}	*QVC4A2A-054X	V. Resistor	Master REC 50K Ω (A)	1
	*QVG4A2B-054	"	Sub. REC 50K Ω (B)	2
	*QMS6311-001	Jack Ass'y	R-CH Mic	1
	*QMS6313-001	"	L-CH Mic	1
	*QMS6302-104	"	Headphone	1
R _{152,252}	*TAJ000345-01	"	LINE & DIN	1
	*QSR5743-300	Rotary Switch	Input Select	1
	*QVD7A2C-0F2	V. Resistor	H. P. Level 250 Ω (C)	1
	*TFB336312-01	Jack Bracket		1
	SPBP3008BS	Screw		1
	*TAZ336499-01	Volume Lug	24 ϕ	1
	*TAZ336499-02	"	16 ϕ	2
	QMC0627-001	"	6P	1
	*QMV2001-101	Socket Ass'y	20P	1
	E43727-003	Lapping Pin	10mm	17
(REC/PB Amp) R _{101,201} R _{102,202,116,216} R _{102,202,114,214} R _{104,204} R _{105,205}	QRD142K-122	C. Resistor	1.2K Ω ¼W	2
	QRD143K-102	"	1K Ω	4
	QRD143K-103	"	10K Ω	4
	QRD143K-122	"	1.2K Ω	2
	QRD141K-823	"	82K Ω	3
R _{106,206,107,207} R _{108,208} R _{109,209} R _{110,210} R _{111,211}	QRZ0019-104	" (Low Noise)	100K Ω	4
	QRD143K-394	"	390K Ω	2
	QRD143K-564	"	560K Ω	2
	QRZ0019-393	" (Low Noise)	33K Ω	2
	QRD143K-391	"	390 Ω	2
R _{112,212,115,215} R _{113,213} R _{117,217} R _{118,218} R _{119,219}	QRD143K-121	QRD143K-121	120 Ω	2
	QRD143K-184	"	18K Ω	2
	QRD143K-104	"	100K Ω	2
	QRD143K-332	"	3.3K Ω	2
	QRD143K-333	"	33K Ω	2
R _{125,225} R _{126,226} R _{127,227} R _{128,228} R _{129,229}	QRD143K-821	"	8.2K Ω	2
	QVP8A0B-054	V. Resistor	50K Ω	2
	QRD143K-473	C. Resistor	47K Ω ¼W	2
	QRD143K-224	"	220k Ω	2
	QRD142K-102	"	1K Ω	2
R _{130,230} R _{131,231} R _{132,232,137,237} R ₁₃₃ R ₃₃₂	QRD143K-394	"	390K Ω	2
	QRD143K-823	"	82K Ω	1
	QRD144K-222	"	2.2K Ω	1
	QRD143K-331	"	330 Ω	1
	QRD142K-331	"	330 Ω	1
R _{134,234} R _{135,235} R _{136 143, 243} R ₂₃₆ R _{138,238,140,240}	QRD143K-822	"	8.2K Ω	2
	QRD142K-272	"	2.7K Ω	2
	QRD143K-123	"	12K Ω	3
	QRD142K-123	"	12K Ω	1
	QRD142K-473	"	47K Ω	4
R _{139,239} R _{141,241} R ₁₄₂ R ₂₄₂ R _{144,244}	QRD142K-471	"	470 Ω	2
	QRD142K-472	"	4.7K Ω	2
	QRD143K-181	"	180 Ω	1
	QRD142K-181	"	180 Ω	2
	QRD143K-473	"	47K Ω	2

Ref. No.	Part No.	Part Name	Remarks	Q'ty
R _{145,245}	QRD143K-473	C. Resistor	4.7K Ω ¼W	2
R _{146,246}	QRD143K-472	"	4.7K Ω "	2
R _{147,247}	QRD143K-561	"	560 Ω "	2
R _{148,248}	QVP8A0B-013	V. Resistor	1K Ω "	2
R _{149,249,150,250}	QVP8A0B-014	"	10K Ω "	4
R _{151,251}	QRD142K-223	C. Resistor	22K Ω ¼W	2
R _{152,252}	QRD142K-472	"	4.7K Ω "	2
R ₉₂₃	QRD142K-333	"	33K Ω "	1
R ₉₂₄	QRD142K-562	"	5.6K Ω "	1
C _{101,201}	QCY41HK-272	C. Capacitor	2700PF "	2
C _{102,202}	QEE41EM-475	E. Capacitor (Tantal)	4.7 μ F 25V	2
C _{103,203}	QEB41EM-106	" (Low Leak)	10 μ F "	2
C _{104,204}	QCS11HK-331	Fixed C. Capacitor	33PF "	2
C _{105,205}	QCS11HK-471	"	47PF "	2
C _{106,206}	QEB41EM-476M	E. Capacitor (Low Leak)	47PF 25V	2
C _{107,207}	QCS11HK-470	Fixed C. Capacitor	47PF "	2
C _{108,208,113,213}	QEB41EM-105	E. Capacitor	1 μ F "	4
C _{109,209}	QEW41AA-107	"	100 μ F 10V	2
C _{110,210}	QFM41HJ-273	Mylar Capacitor	0.027 μ F "	2
C _{111,211}	QEW41EA-476	E. Capacitor	47 μ F 25V	2
C _{112,212}	QFM41HJ-103	Mylar Capacitor	0.01 μ F "	2
C _{114,214}	QEW41CA-106	E. Capacitor	10 μ F 10V	2
C _{115,215}	QCS11HJ-820	Fixed C. Capacitor	82PF "	2
C _{116,216}	QFM41HJ-222	Mylar Capacitor	0.0022 μ F "	2
C _{117,217}	QEW41AA-476	E. Capacitor	47 μ F 10V	2
C _{118,218}	QEW41EA-475	"	4.7 μ F 25V	2
C _{119,219}	QEW41EA-336	"	33 μ F "	2
C _{120,220,124,224}	QEW41EA-106	"	10 μ F "	4
C _{121,221}	QFM41HK-102	Mylar Capacitor	" "	2
C _{122,222}	QEW41EA-476	E. Capacitor	47 μ F 25V	2
C _{123,223}	QEB41HM-334M	" (Low Leak)	0.33 μ F 50V	2
C _{125,225}	QEW41EA-475	"	4.7 μ F 25V	2
C _{126,226}	QEW41CA-106	"	10 μ F 16V	2
C _{127,227}	QEW41EA-105	"	1 μ F 25V	2
C _{128,228,129,229}	QCR11HK-561	Fixed C. Capacitor	560PF "	4
L _{101,201}	QCS11HK-101	"	100PF "	2
L _{102,202}	TAC000324-05	Inductor	33mH "	2
T _{101,201}	TAC000493-01	"	20 μ H "	2
D _{101,201,102,202}	T44944-001	Headphone transformer	" "	2
	1S188AM	Diode	" "	4
IC _{101,201}	TA7066P (B)	IC	" "	2
X _{101,201}	2SA721 (TU)	Transistor	" "	2
X _{102,202,104,204}	2SC1327 (TU)	"	" "	4
X _{103,203,105,205,106,206}	3SC828 (RS)	"	" "	6
(Power Supply) R ₉₀₅	QRD121K-121	C. Resistor	120 Ω ½W	1
R ₉₀₆	QRD142K-330	"	" ¼W	1
C _{907,908}	QCF12HP-103	Fixed C. Capacitor	0.01 μ F "	2
C ₉₀₉	QEW41CA-108	E. Capacitor	1000 μ F 16V	1
C ₉₁₀	QEW41AA-477	"	470 μ F 10V	1
C ₉₁₁	QEW41AA-227	"	220 μ F "	1
D _{904,905,906,907}	T30155-001	Diode	" "	4
ZD ₉₀₂	RD6.2F (B)	Zener Diode	" "	1
X ₉₀₃	*2SC1847 (R)	Transistor	for X903	1
	TAR336498-01	Radiation Plate	for X903	1
	DPSP3008ZS	Screw	"	1

Ref. No.	Part No.	Part Name	Remarks	Q'ty
(DC-DC Converter)				
R ₉₀₁	TAA336496-01	Circuit Board	Not supplied as parts ass'y	1
R ₉₀₂	ORD143K-561	C. Resistor	560Ω ¼W	1
R ₉₀₃	ORD143K-681	"	680Ω "	1
C _{912,904}	ORD143K-220	"	22Ω ""	1
	QEW41AA-107	E. Capacitor	100μF 10V	1
C ₉₀₁	QEW41AA-227	"	220μF "	1
C ₉₀₂	QFM41HK-153	Mylar Capacitor	0.015μF	1
C ₉₀₃	QCS11HK-391	Fixed C. Capacitor	390PF	1
C ₉₀₅	QEW41EA-476	E. Capacitor	46μF 25V	1
C ₉₁₃	QEW41EA-477	"	470μF "	1
C ₉₀₆	QEW41CA-476	"	47μF 16V	1
C ₉₁₄	QEW41CA-477	"	470μF "	1
R ₉₀₄	ORD143K-680	C. Resistor	68Ω ¼W	1
L ₉₀₁	*TAC000344-01	Inductor	68μH	1
L _{902,903}	*TAC000346-01	"	680μH	1
T ₉₀₁	*TAZ2271302-01	Converter Transformer		1
D ₉₀₁	MA162	Diode		1
D ₉₀₂	MA161	"		1
D _{903,904}	MA150	"		2
ZD ₉₀₁	RD22E (1)	Zener Diode		1
X ₉₀₁	2SC828 (R)	Transistor		1
X ₉₀₂	*2SC1847 (R)	"		1
	*TAS336477-01	Converter Case (A)		1
	*TAS336478-01	" (B)		1
	*TAD336497-01	Insulator		1
(Auto Stop & Muting)	*E43727-003	Lapping Pin		6
R ₉₃₀	ORD143K-393	C. Resistor	39KΩ ¼W	1
R ₉₀₇	ORD143K-124	"	120KΩ "	1
R ₉₀₈	ORD143K-101	"	100Ω "	1
R ₉₀₉	ORD143K-101	"	100Ω "	1
R _{910,912}	ORD143K-104	"	100KΩ "	2
R ₉₁₁	ORD143K-333	"	33KΩ "	1
R ₉₁₃	ORD143K-100	"	10Ω "	1
R ₉₁₄	ORD143K-682	"	6.8KΩ "	1
R ₉₁₅	ORD143K-332	"	3.3KΩ "	1
R ₉₁₆	ORD143K-562	"	5.6KΩ "	1
R _{917,918}	ORD143K-823	"	82KΩ "	2
R ₉₁₉	ORD142K-333	"	33KΩ "	1
R _{920,922}	ORD143K-102	"	1KΩ "	2
R ₉₂₁	ORD143K-471	"	470Ω "	1
R ₉₂₉	ORD143K-122	"	1.2KΩ "	1
C ₉₁₅	QEB41EM-106	E. Capacitor (Low Leak)	10μF 25V	1
C ₉₁₆	QEW41EA-107	"	100μF "	1
C ₉₁₇	QEB41HM-474M	"	0.47μF	1
C ₉₁₈	QEW41AA-227M	"	220μF 10V	1
C ₉₁₉	QCF11HP-103	Fixed C. Capacitor	0.01μF	1
C ₉₂₀	QEW41AA-476	E. Capacitor	47μF 10V	1
C ₉₂₁	QEW41EA-105	"	1μF 25V	1
C ₉₂₂	QEW41EA-335	"	3.3μF 25V	1
SCR ₁₀₁	2SF656	SCR		1
D ₉₀₉	T30155-001	Diode		1
D _{910,911,912}	MA150	"		3
X ₉₀₅	2SA564A (RS)	Transistor		1
X ₉₀₆	2SC828 (RS)	"		1
X ₉₀₇	2SC828A (RS)	"		1
X ₉₀₈	2SA564A (RS)	"		1

REC Amp Circuit Board

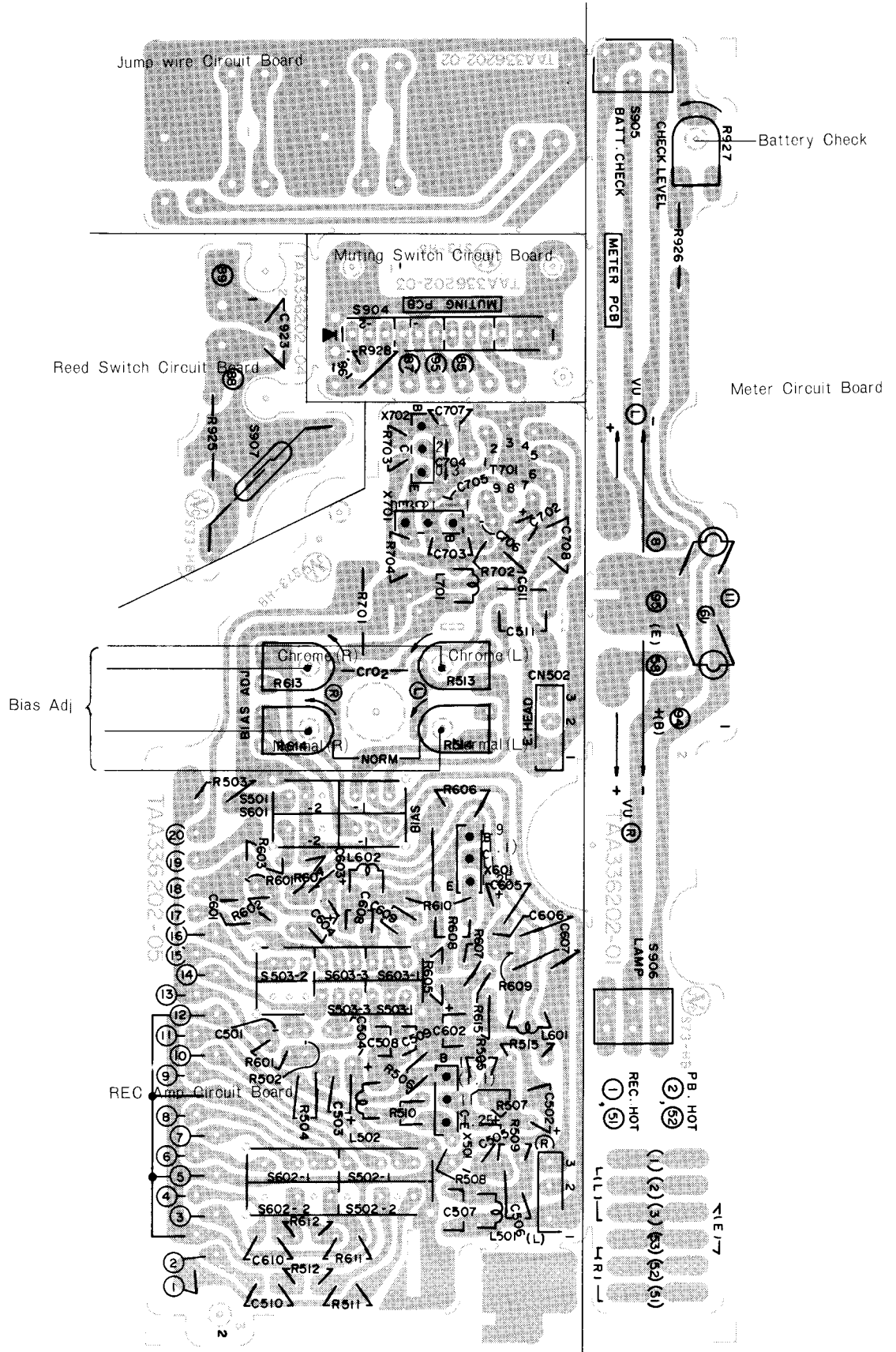

Fig. 12

REC AMP Circuit Board Parts List

Ref. No.	Part No.	Part Name	Remarks	Q'ty
(REC Amp)	TAA336202-05	Circuit Board	Not supplied as parts ass'y	1
R _{501,601}	QRD143K-223	C. Resistor	22K Ω ¼W	2
R _{502,602}	QRD143K-183	"	18K Ω "	2
R _{507,607}	QRD143K-682	"	6.8K Ω "	2
R _{503,504,603,604}	QRD143K-123	"	12K Ω "	4
R _{505,605}	QRD143K-684	"	680K Ω "	2
R _{506,606}	QRD143K-823	"	82K Ω "	2
R _{508,608}	QRD143K-821	"	820 Ω "	2
R _{509,609}	QRD143K-153	"	15K Ω "	2
R _{510,610}	QRD143K-220	"	22 Ω "	2
R _{511,611}	QRD143K-564	"	560K Ω "	2
R _{512,612}	QRD143K-122	"	1.2K Ω "	2
R _{513,613}	QVP8A0B-015	V. Resistor	100K Ω B	2
R _{514,614}	QVP8A0B-025	"	200K Ω B	2
R _{515,615}	QRD143K-681	C. Resistor	680 Ω ¼W	2
C _{501,601}	QMF41HK-392	Mylar Capacitor	0.0039 μ F	2
C _{502,602}	QEW41EA-476	E. Capacitor	47 μ F 25V	2
C _{503,603}	QEB41HM-334M	" (Low Leak)	0.33 μ F 50V	2
C _{504,604}	QEW41CA-106	"	10 μ F 16V	2
C _{505,605}	QEB41HM-684M	" (Low Leak)	0.68 μ F 50V	2
C _{506,606}	QFM41HJ-152	Mylar Capacitor	0.0015 μ F	2
C _{507,607}	QCS12HJ-151	Fixed C. Capacitor	150PF	2
C _{508,608}	QFM41HJ-183	Mylar Capacitor	0.018 μ F	2
C _{509,609}	QFM41HJ-153	"	0.015 μ F	2
C _{510,610}	QFM41HK-562	"	0.0056 μ F	2
C _{511,611}	QCS12HK-221	Fixed C. Capacitor	220PF	2
X _{501,601}	2SC828A (R)	Transistor		2
L _{501,601}	*TAC000346-06	Inductor	18mH	2
L _{502,602}	*TAC000346-04	"	5.6mH	2
(Bias Osc) R ₇₀₁	QRD146K-820	C. Resistor	82 Ω	1
R _{702,703}	QRD143K-014	"	100K Ω	2
R ₇₀₄	QRD143K-220	"	22 Ω	1
C ₇₀₂	QEB41HM-684M	E. Capacitor (Low Leak)	0.68 μ F 50V	1
C _{703,704}	QCS11HK-391	Fixed C. Capacitor	390PF	2
C ₇₀₅	QFZ0001-472	P. Capacitor	0.0047 μ F	1
C _{706,707}	QFM41HK-272	Mylar Capacitor	0.0027 μ F	2
C ₇₀₈	QFZ0001-822	P. Capacitor	0.0082 μ F	1
L ₇₀₁	*TAC000346-02	Inductor	1mH	1
T ₇₀₁	TAB265401-01	OSC Coil		1
	TAS336517-01	Shield Case	for OSC Coil	1
X _{701,702}	2SC828A (RS)	Transistor		2
	*QMC0327-001	Plug Ass'y		2
	*QSL4218-001	Lever Switch	Bias	1
	QSL6220-001	"	Equalizer	1
	QSL4324-001	"	ANRS	1
(Reed Switch C. Board)	E43727-003	Lapping Pin		22
R ₉₂₅	*TAA336202-04	Circuit Board		1
C ₉₂₃	QRD142K-472	C. Resistor	4.7K Ω ¼W	1
(Meter C. Board)	QCS11HK-101	Fixed C. Capacitor	100PF	1
	TAA336202-01	Circuit Board		1
S ₉₀₄	QSP2210-044	Push Switch	Non Lock for Check	1
S ₉₀₅	QSP2210-043	"	Lock for Lamp	1
R ₉₂₆	QRD142K-472	C. Resistor	4.7K Ω ¼W	1
R ₉₂₇	QVP8A0B-024	V. Resistor		1
(Muting Switch C. Board)	*TAA336202-03	Circuit Board		1
R ₉₂₈	QSS4201-011	Slide Switch		1
	QRD143K-471	C. Resistor	470 Ω ¼W	1

Note: The circuit board assembly will not be available as spare parts.

ANRS Circuit Board

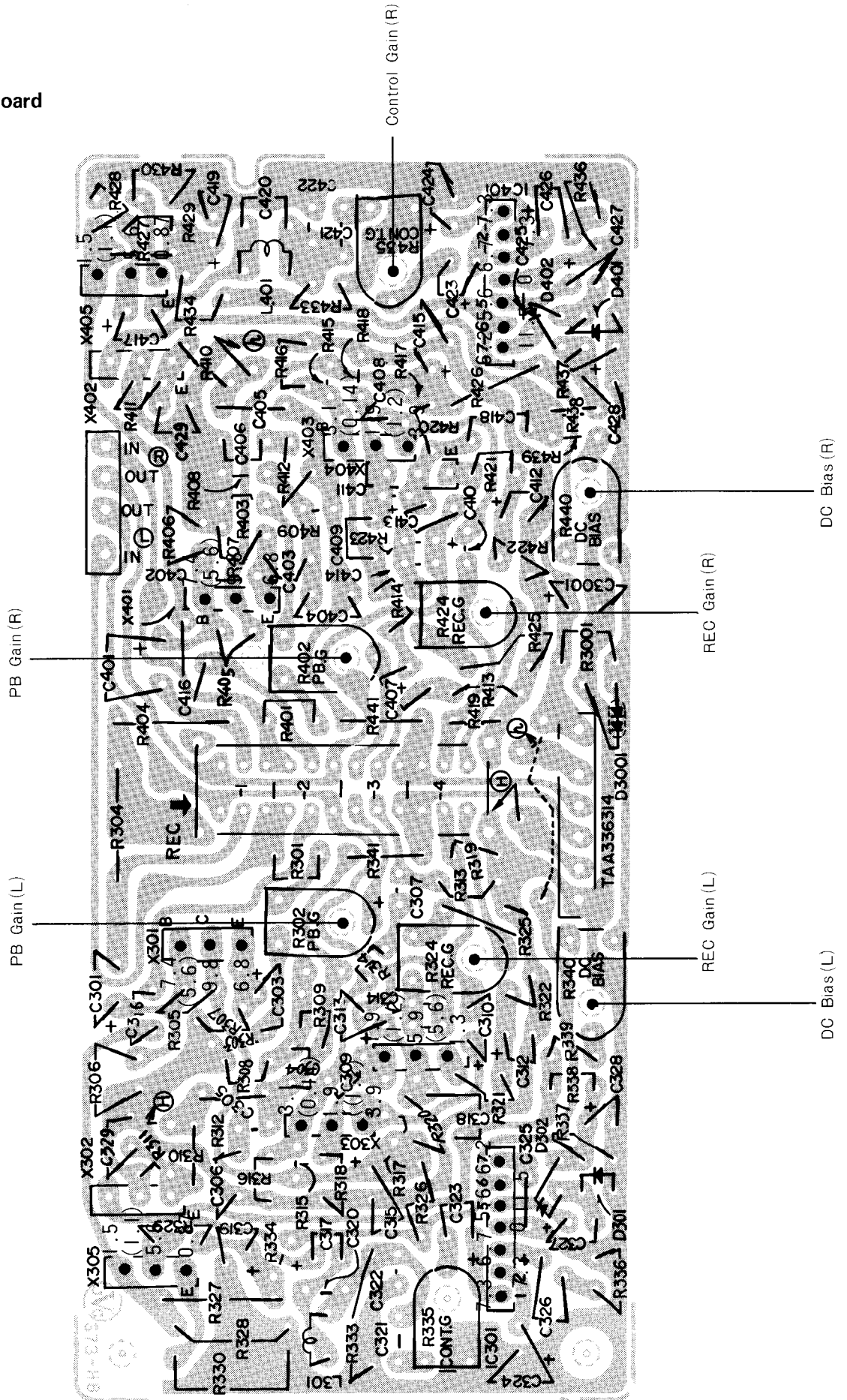

Fig. 13

ANRS Circuit Board Parts List

Ref. No.	Part No.	Part Name	Remarks	Q'ty
S _{301,401}	*TAA336314-01	Circuit Board	Not supplied as parts ass'y	1
	QSS8201-102	Slide Switch		2
	QMC627-001	Plug Ass'y	6P	1
	QMC0427-001	"	4P	1
R ₃₀₀₁	QRD143K-153	C. Resistor	15K Ω 1/4W	1
R _{301,401}	QRD143K-273	"	27K Ω "	1
R _{302,402}	QVP8A0B-014	V. Resistor	10K Ω B	2
R _{303,403}	QRD143K-222	C. Resistor	2.2K Ω 1/4W	2
R _{304,404}	QRD142K-473	"	47K Ω "	2
R _{305,405}	QRD143K-104	"	100K Ω "	2
R _{306,406}	QRD143K-334	"	330K Ω "	2
R _{307,407}	QRD143K-822	"	8.2K Ω "	2
R _{303,408,318,418}	QRD143K-473	"	47K Ω "	4
R _{309,409}	QRD143K-274	"	270K Ω "	2
R _{318,410}	QRD143K-100	"	10 Ω "	2
R _{311,411}	QRD143K-562	"	5.6K Ω "	2
R _{312,412}	QRD143K-181	"	180 Ω "	2
R _{313,413}	QRD143K-683	"	68K Ω "	2
R _{314,414}	QRD143K-102	"	1K Ω "	2
R _{315,415}	QRD143K-564	"	560K Ω "	2
R _{316,416}	QRD143K-274	"	270K Ω "	2
R _{317,417}	QRD143K-154	"	150K Ω "	2
R _{319,419}	QRD143K-823	"	82K Ω "	2
R _{320,420}	QRD143K-103	"	10K Ω "	2
R _{321,421}	QRD143K-101	"	100 Ω "	2
R _{322,422}	QRD143K-332	"	3.3K Ω "	2
R _{323,423}	QRD143K-183	"	18K Ω "	2
R _{325,425}	QRD143K-392	"	3.9K Ω "	2
R _{326,426}	QRD143K-122	"	1.2K Ω "	2
R ₄₂₇	QRD143K-224	"	220K Ω "	1
R ₃₂₇	QRD142K-224	"	220K Ω "	1
R ₄₂₈	QRD143K-473	"	47K Ω "	1
R ₃₂₈	QRD142K-473	"	47K Ω "	1
R _{329,429}	QRD143K-332	"	3.3K Ω "	2
R ₃₃₀	QRD142K-681	"	680 Ω "	1
R ₄₃₀	QRD143K-681	"	680 Ω "	1
R ₃₃₃	QRD142K-103	"	10K Ω "	1
R ₄₃₃	QRD143K-103	"	10K Ω "	1
R _{334,434}	QRD143K-122	"	1.2 Ω 1/4W	2
R _{335,435}	QVP8A0B-024	V. Resistor	20K Ω B	2
R _{336,436}	QRD143K-390	C. Resistor	39 Ω 1/4W	2
R _{337,437}	QRD143K-333	"	33K Ω "	2
R _{338,438,339,439}	QRD143K-473	"	47K Ω "	4
R _{344,440}	QVP8A0B-015	V. Resistor	100K Ω B	2
R _{341,441}	QRD143K-332	C. Resistor	3.3K Ω 1/4W	2
C ₃₀₀₁	QEW41CA-476	E. Capacitor	47 μ F 16V	1
C _{301,401,403,404}	QEB41EM-335	" (Low Leak)	3.3 μ F 25V	3
C _{302,402}	QCS11HK-561	Fixed C. Capacitor	560PF	2
C _{304,404}	QFM41HK-223	Mylar Capacitor	0.022 μ F	2
C _{305,405}	QFM41HK-104	"	0.1 μ F	2
C _{306,406}	QFM41HK-183	"	0.018 μ F	2
C _{307,407}	QEE41EM-105	Tantal E. Capacitor	1 μ F 25V	2
C _{308,408,321,421}	QCS11HK-471	Fixed C. Capacitor	470PF	4
C _{309,409}	QCS11HK-101	"	100PF	2
C _{310,410}	QEE41EM-335	Tantal E. Capacitor	3.3 μ F 25V	2

Ref. No.	Part No.	Part Name	Remarks	Q'ty
C _{311,411}	QCS11HK-270	Fixed C. Capacitor	27PF	2
C _{312,412}	QEW41AA-476	E. Capacitor	47PF 10V	2
C _{313,413}	QEW41CA-106		10μF 16V	2
C _{314,414}	QCS11HK-181	Fixed C. Capacitor	180PF	2
C _{315,415}	QEW41CA-476	E. Capacitor	47μF 16V	2
C _{316,416}	QFM41HK-333	Mylar Capacitor	0.033μF	2
C _{317,417}	QEW41CA-475	E. Capacitor	4.7μF 16V	2
C _{318,418}	QFM41HK-182	Mylar Capacitor	0.0018μF	2
C _{319,419,324,424}	QEW41CA-106	E. Capacitor	10μF 16V	4
C _{324,420}	QCS11HJ-820	Fixed C. Capacitor	82PF	2
C _{322,422}	QFM41HK-222	Mylar Capacitor	0.0022μF	2
C _{323,423}	QEW41EA-105	E. Capacitor	1μF 25V	2
C _{325,425}	QFM41HK-102	Mylar Capacitor	0.001μF	2
C _{326,426}	QEW41AA-476	E. Capacitor	47μF 10V	2
C _{327,427,328,428}	QEB41EM-105	E. Capacitor (Low Leak)	1μF 25V	4
C _{329,429}	QCS11HK-101	Fixed C. Capacitor	100PF	2
L _{301,401}	*TAC000346-07	Inductor	33mH	2
X _{301,401,304,404}	2SC1327 (TU)	Transistor		4
X _{302,402}	2SD545NP-VS	"		2
X _{303,403}	2SA721 (TU)	"		2
X _{305,405}	2SC828 (R)	"		2
IC _{301,401}	TA7066P (BC)	IC		2
D ₃₁	MA26W	Varistor Diode		1
D _{301,401,302,402}	1S188FM	Diode		4

Mechanical Components (1)

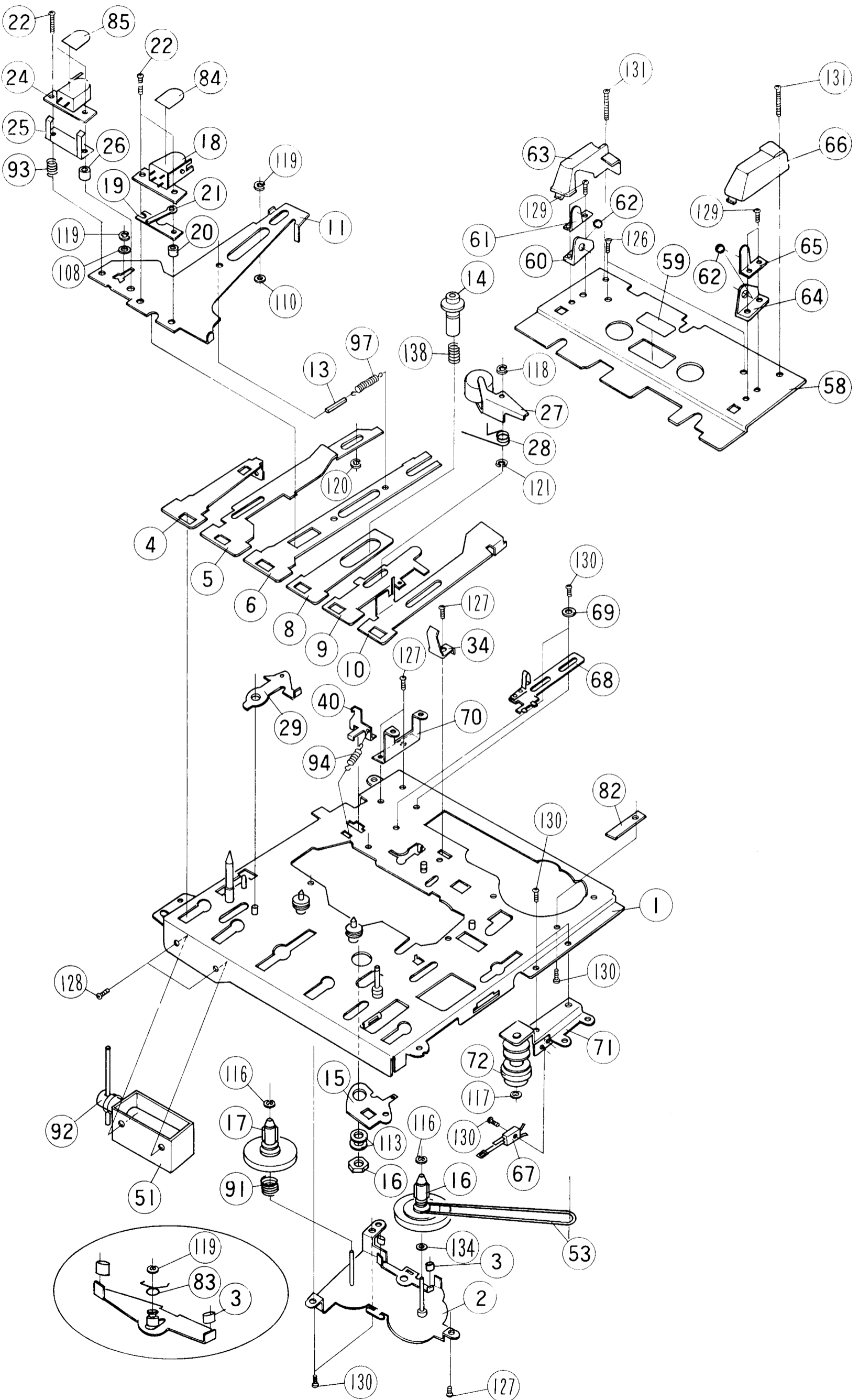

Fig. 14

Mechanical Components (2)

KD-2A/B/C/E/J/U

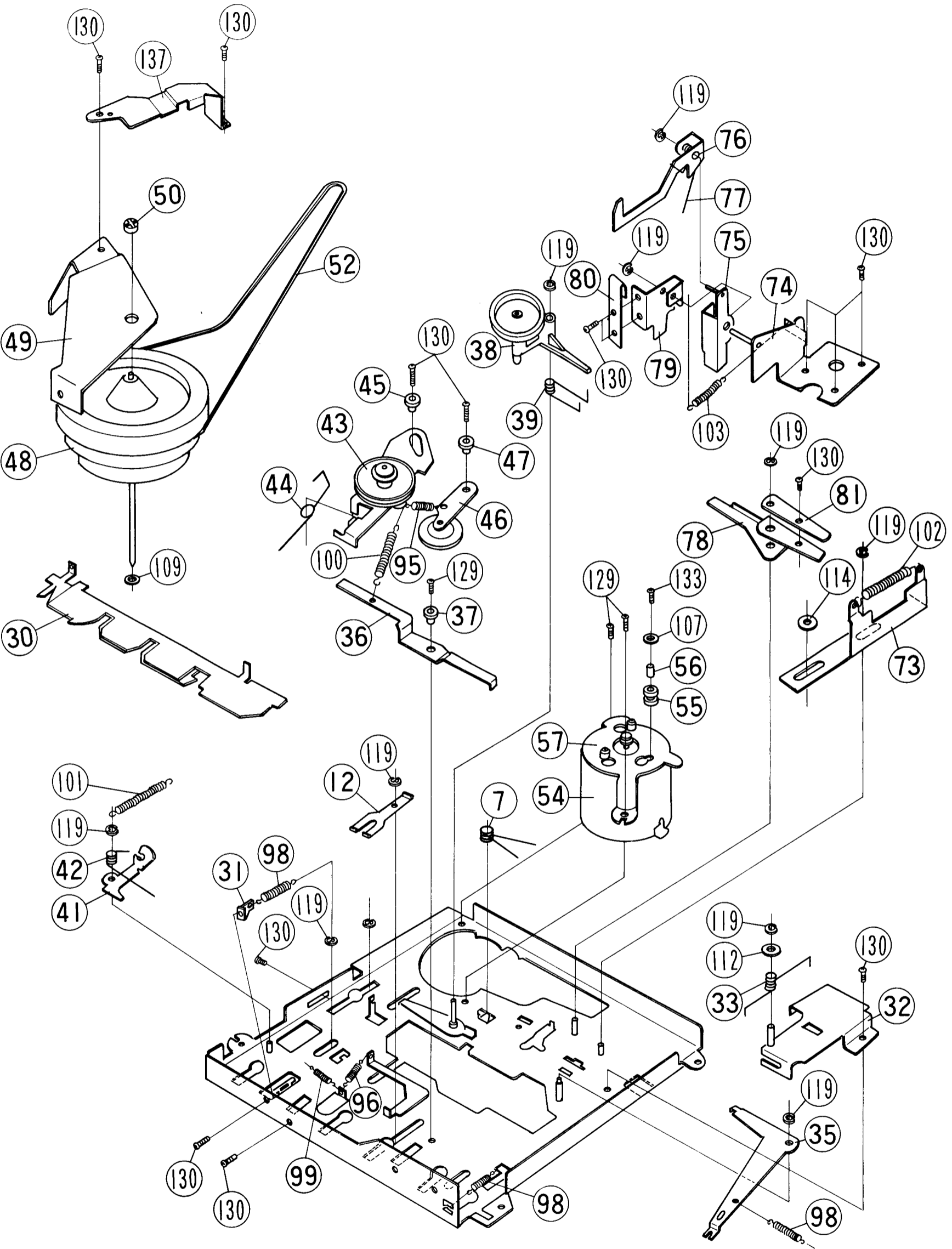

Fig. 15

No. 4151

Mechanical Component list

Ref. No.	Part No.	Part Name	Remarks	Q'ty
1	*TGB294314-0C	Chassis Base Ass'y		1
2	*TGB294436-0C	Reel Disk Bracket Ass'y		1
3	TER265487-01	Brake Rubber		2
4	*TGB336403-0A	Rewind Bar Ass'y		1
5	*TGB336405-0A	Record Bar Ass'y		1
6	*TGB336407-0A	Play Bar Ass'y		1
7	TFW294447-01	Play Bar Spring		1
8	*TGB336409-0A	FF Bar Ass'y		1
9	*TGB336411-0A	Stop Bar Ass'y		1
10	*TGB336413-0A	Pause Bar Ass'y		1
11	TGB294457-0B	Slide Base Ass'y		1
12	TFP294460-01	Spring Plate	for Spring	1
13	TJN265559-02	Silencer		1
14	TGH294461-0A	Capstan Metal Ass'y		1
15	TFB294522-01	Spacer		1
16	TGP294462-0B	Take up Disk Ass'y		1
17	TGP294464-0E	Supply Disk Ass'y		1
18	ZMM074401-0A	R. P. Head Ass'y		1
19	TFP294513-01	R. P. Head Spring		1
20	*T30302-076	R. P. Head Collar		1
21	T45640-001	Wire Holder	for R. P. Head E. Head	1
22	SPSX2008Z	Screw		4
24	THS000481-0A	E. Head Ass'y		1
25	TFB294466-01	Wire Clamper		1
26	T30302-075	E. Head Collar		1
27	TGB294537-0A	Pinch Roller Arm Ass'y		1
28	FTW294483-01	Pinch Roller Spring		1
29	TFB294467-01	Rec. Lock Lever		1
30	*TGB294468-0B	Push Button Cam Ass'y		1
31	TFB294470-01	Stopper		1
32	TGB294472-0B	Switch Bracket Ass'y		1
33	TFW294475-02	Actuator		1
34	TFP336505-01	Spring Plate		1
35	TFB294477-01	Brake Lever		1
36	TFB294478-001	Review Lever		1
37	T43909-001	Metal		1
38	*TGP294479-0C	Take up Lever Ass'y		1
39	TFW294482-02	Lever Spring		1
40	TFB291414-01	Record Safety Lever		1
41	T43069-001	Lock Plate		1
42	*TFW3364080-001	Spring		1
43	TGX294488-0A	FF Arm Ass'y		1
44	T47507-002	FF Spring		1
45	TFH294492-01	Metal		1
46	TGX294490-0A	Rewind Idler Arm Ass'y		1
47	TFH294491-01	Metal		1
48	TEW336317-0A	Flywheel Ass'y		1
49	*TFB336487-01	Flywheel Holder		1
50	TFP265498-01	Thrust Washer		1
51	TDP294319-0A	D.C. Solenoid Ass'y		1
52	TEB294496-02	Capstan Belt		1
53	*TEB336416-01	Counter Belt (M)		1
54	*M1604-00A	Motor Ass'y		1
55	53492	Rubber Bushing		3
56	T30302-058	Collar		3
57	TFB294534-01	Motor Bracket		1
58	*TFB336304-01	Cassette Holder		1
59	TJP305451-01	Reflection Plate		1
60	*TEP336439-01	Holder		1
61	*TFP336440-01	Spring Plate		1

Ref. No.	Part No.	Part Name	Remarks	Q'ty
62	*T41615-007	Steel Ball		2
63	*TEP336303-01	Cover		1
64	*TEP336439-02	Holder		1
65	*TFP336440-02	Spring Plate		1
66	*TEP336303-02	Cover		1
67	TDS000334-02	Leaf Switch		1
68	*TGB336429-0A	Muting Lever Ass'y		1
69	T43909-008	Metal		2
70	*TFB336432-01	Switch Bracket		1
71	*TGB336433-0A	Pully Bracket Ass'y		1
72	*TGP336436-0A	Magnet Pulley Ass'y		1
73	*TGB336417-0A	Push Lever Ass'y		1
74	*TGB336421-0A	Record Bracket Ass'y		1
75	*TGB336425-0A	Record Lever Ass'y		1
76	*TFB336428-01	Connecting Lever		1
77	*TFW336481-01	Spring		1
78	*TFB336424-01	Record Lever (1)		1
79	*TFB336490-01	Lever		1
80	*TFP336491-01	Switch Spring		1
81	*TFB336489-01	Lever		1
82	*TFB336493-01	Stopper		1
83	TFW336525-01	Spring		1
84	THCO37417-01	Head Plate	for R. P. Head (SA)	1
85	*THS000489-01	Head Label	for E. Head (2 GAP)	1
91	T30301-103	Spring	Supply Disc	1
92	T30301-133	"	D.C. Solenoid Ass'y	1
93	T30301-115	"	E. Head	1
94	T30300-121	"	REC Safety Lever	1
95	T30300-126	"	Rewind Idler Arm	1
96	T30300-137	"	FF Bar	1
97	T30300-139	"	Play Bar	1
98	T30300-140	"	REW Bar	1
99	T30300-150	"	Push Button Cam	1
100	T30300-151	"	FF Arm	1
101	T30300-049	"	Lock Plate	1
102	T30300-183	"	Push Lever Ass'y	1
103	T30300-039	"	Connecting Lever	1
106	T47828-001	Nut		1
107	Q03091-154	Washer	Motor Ass'y	3
108	Q03093-430	"	Slide Base	1
109	Q03093-827	"	Flywheel Ass'y	1
110	Q03093-819	"	Slide Base	1
111	WNS2600N	"	Lever	1
112	WNS4000N	"	Actuator, Push Lever	2
113	T47829-001	"	Capstan Metal	2
114	WSB4000N	"		1
116	REE1200	"E" ring	Take up disc, Supply Disc.	2
117	REE1500	"	Magnet Pully Ass'y	1
118	REE2000	"	Pinch Roller Arm Ass'y, Lock Plate	3
119	REE2500	"	Stop bar, Slide Base, Spring Plate, Actuator, Brake Lever, Take up Lever, Push Lever, Connecting Lever, Rec Lever (1) Lever	11
120	REE3000	"	REC Bar Ass'y	1
121	REE4000	"	Pinch Roller Arm	1
126	SSSP2005R	Screw	Cassette Holder	2
127	SPSP2603Z	"	Spring Plate, Switch Bracket	5
128	SPSP2604Z	"	D.C. Solenoid	2

Ref. No.	Part No.	Part Name	Remarks	Q'ty
129	SPSP2605Z	Screw	Motor Bracket, Spring Plate Review Lever	6
130	SPSP2606Z	"	Reel Disc Bracket, Stopper, Switch Bracket, FF Arm, REW Idler Arm, Flywheel Holder, Leaf Switch, Muting Lever, Pully Bracket, REC Bracket, Stopper, Motor Circuit Board.	21
131	SPSP2614Z	"	Cover	1
132	LPSP2606Z	"	Lever	1
133	LPSP2608Z	"	Motor Ass'y	3
134	Q03093-611	Washer		1
135	Q03093-430	"		1
136	Q03093-522	"		1
137	TFB336520-01	Shield Plate		1
138	TFW336519-01	Thrust Spring		1
139	Q03093-622	Washer		1

Enclosure Assembly and Electrical Parts Except Circuit Board Parts List

Ref. No.	Part No.	Part Name	Remarks	Q'ty
1	*TJM336101-01	Top Panel	A	1
2	*TJP336444-01	Leather Plate	A	1
3	*TJP336305-01	Front Plate (A)	Right A	1
4	*TJP336445-01	Front Plate (B)	Left A	1
5	*TJP336315-0A	Hinge Ass'y		2
6	*TFB336446-01	Tapping Plate		2
7	QXM2241-002	Mark	A	1
8	*TJM336201-02	Front Panel	B	1
9	*TJE336449-01	Counter Lens	B	1
10	*TJH336452-01	Handle		2
11	*TJE336454-01	Push Knob Ring	B	2
12	RDS12000Z	"CS" Ring	B	2
13	*TJE336455-01	Ring Ass'y	B	3
14	*TJP336456-01	Knob Plate	B	1
15	*TLD336307-01	Cover	D	1
16	TJL271485	Head Mark	D	1
17	*TFB336446-02	Tapping Plate		2
18	*TJM336102-01	Bottom Cover	E	1
19	T42479-001	Foot	E	4
20	*TJM336308-01	Battery Cover	C	1
21	TJN336514-02	Cushion	C	4
22	*TFB336479-01	Bracket		1
23	*TGP336309-0A	Counter Ass'y		1
24	*TFB236460-01	Counter Bracket		1
25	*TEB336459-01	Counter Belt		1
26	TDS271409-01	Reed Switch		1
27	TER271414-01	Spacer		1
28	53492	Rubber Bushing	Pilot Lamp, Reed Switch, C Board	4
29	T30302-063	Collar		2
30	TJK304410-01	Switch Knob		3
31	*TJK336461-01	Knob (1)	Rotary	1
32	*TJK336462-01	Knob (2)	Master	1
33	*TJK336463-01	Knob (3)	REC VU	2
34	TJN271489-01	Blind		3
35	*TJK336465-01	Push Knob		2
36	*TJK336464-01	Knob (4)	Headphone	1
37	TJP336483-01	Plate	KD-2J/C	1
	TJP000502-01	Plate	KD-2A/B/E/U	1
38	TJL000353-03	Name Plate	KD-2J	1
	TJL000353-04	"	KD-2C	1
	TJL000353-05	"	KD-2E	
	TJL000353-06	"	KD-2B	
	TJL000353-07	"	KD-2A	
	TJL000353-08	"	KD-2U	
39	THC037417-01	Head Plate		1
40	*TFB336311-01	Button Case		1
41	*TFB336467-01	Button Stopper		1
42	*TFB336468-01	Button Holder		1
43	*TEP336469-01	Button Lever		6
44	*TFW336471-01	Spring		6
45	*TFH336472-01	Stud		2
46	*TJK336466-0A	Push Button Ass'y		3
47	*TJK336466-0B	"		1
48	*TFB336473-01	Side Bracket	Left	1
49	*TFB336474-01	"	Right	1
50	*TJK336466-0C	Push Button Ass'y		1
51	*TJK336466-0D	"		1
52	QMC0657-001	Socket Ass'y	6P ANRS C. Board	1
53	QMC0457-001	"	4P "	1
54	50242-02	Lug		1

Enclosure Assembly and Electrical Parts Except Circuit Board Parts (1)

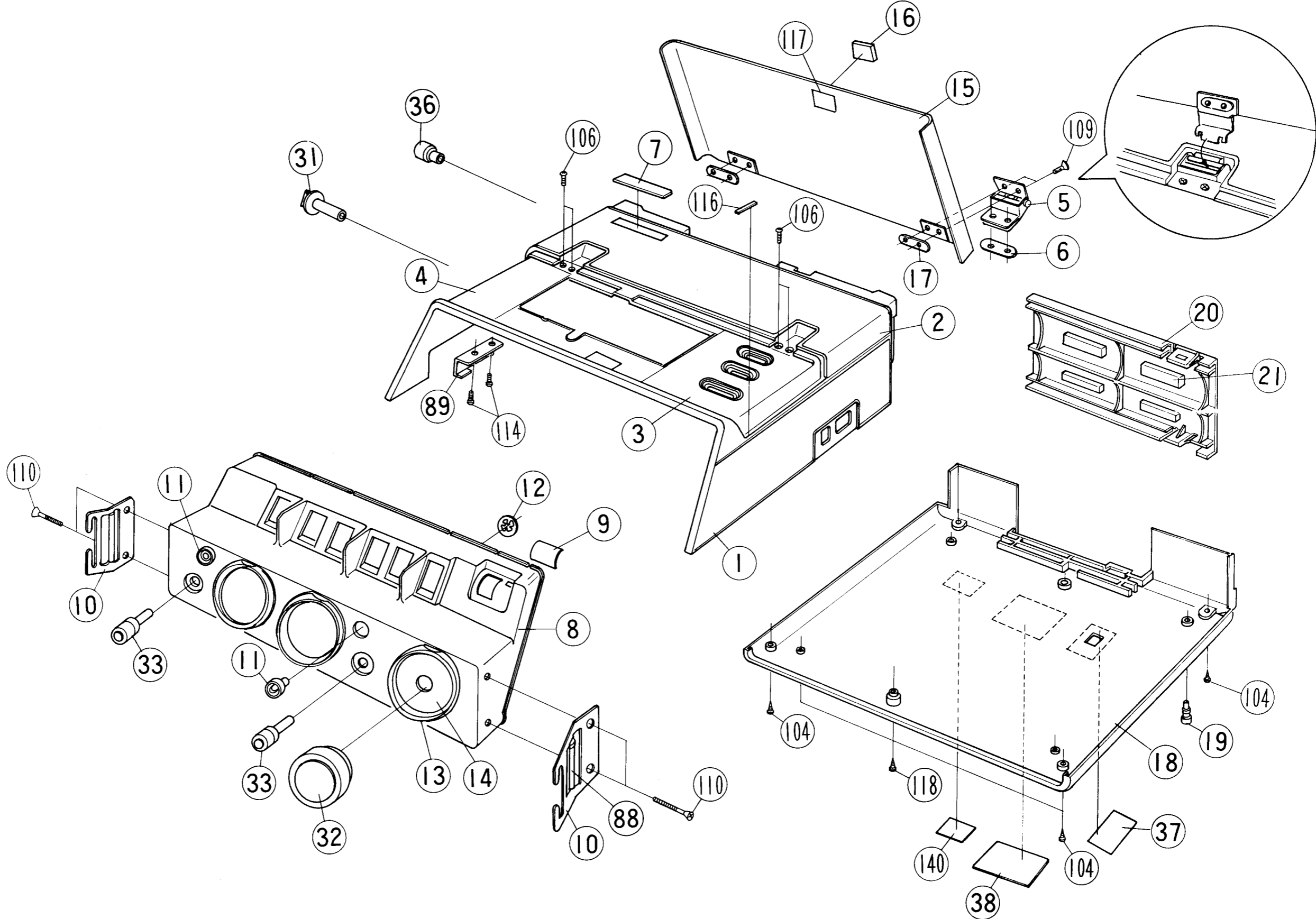

Fig. 16

Enclosure Assembly and Electrical Parts Except Circuit Board Parts (2)

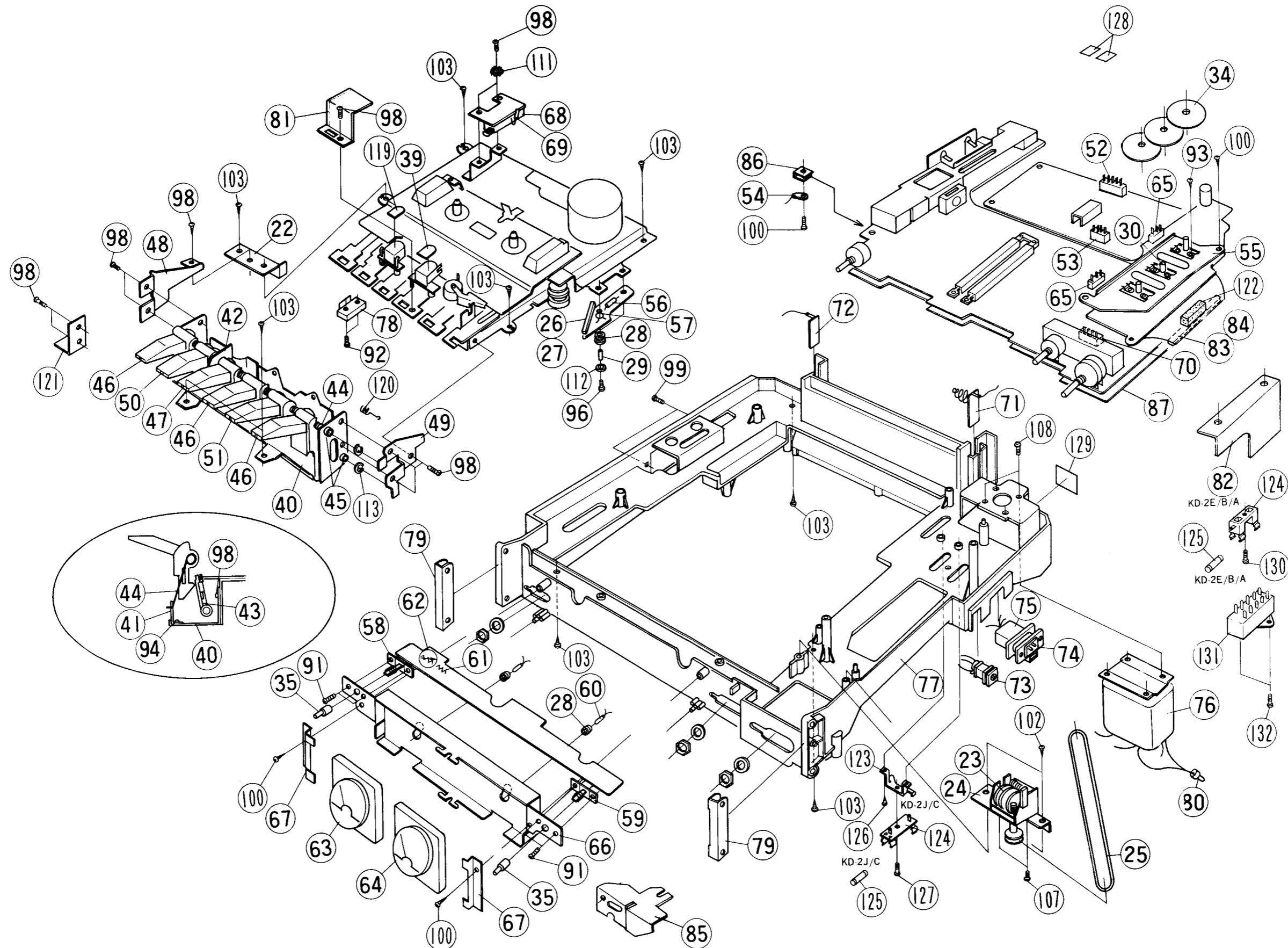

Fig. 17

Ref. No.	Part No.	Part Name	Remarks	Q'ty
55	*TFB336476-01	Lever Switch Bracket		1
56	QRD142K-472	C. Resistor	R925	1
57	QCS11HK-101	Fixed C. Capacitor	C923	1
58	*QSP2210-044	Push Switch	S904 Non Lock for CHECK	1
59	*QSP2210-043	"	S905 Lock for LAMP	1
60	T46729-002	Pilot Lamp		2
61	QRD142K-123	C. Resistor	R926	1
62	QVP8A0B-024	V. Resistor	R927 20k	1
63	*TDM000343-01	Level Meter	Left	1
64	*TDM000343-02	"	Right	1
65	*QMC0357-001	Socket Ass'y	3P Head	2
66	*TFB336313-01	Push Switch Bracket		1
67	*TFB336475-01	Meter Bracket		2
68	QSS4201-011	Slide Switch		1
69	QRD143K-471	C. Resistor	R928	1
70	QMC0657-001	Socket Ass'y		1
71	T41240-001	Battery Contact,	⊕	2
72	T41347-00A	Battery Contact Ass'y	⊖	2
73	*QMA0621-001	Ext. Battery Jack		1
74	QMC0262-001	AC Socket		1
75	*V44399-00B	Cover		1
76	TAP350301-01	Power Transformer	KD-2J/C	1
	TAP351301-01	"	KD-2A/B/E	1
	TAP354301-01	"	KD-2U	1
77	*TEP336110-01	Chassis		1
78	QSM1S01-007	Power Switch		1
79	*TFB336453-01	Handle Bracket		2
80	FG9060	Connector		1
81	*TAS336504-01	Shield Board	Enclosure of R.P Head	1
82	*TAS336503-01		Switch P. Circuit Board	1
83	*TAA336500-01	Flexible Printed Circuit Board		1
84	*QMV2001-001	Plug Ass'y	20P	1
85	*TAS336502-001	Shield Board		1
86	TFB313563-01	Plate Nut		1
87	*TAS336203-01	Shield Board		1
88	*TJH336492-01	Handle Shaft		2
89	*TFB336515-01	Bracket		1
91	SPSP2006Z	Screw	Switch	4
92	SPSP2010Z	"	Micro Switch	2
93	SPSP2604Z	"	Level Switch Bracket	3
94	SPSP2606Z	"	Button Plate	4
95	SPSP2608Z	"	"	2
96	SPSP2610Z	"	Rubber Bushing	2
97	LPSP2604Z	"	Push Button	2
98	LPSP2605Z	"	Muting Switch Bracket, Shield Plate	15
99	SPBP3008RS	"	Jack	2
100	SBSB3008V	Tapping Screw	Lug. ANRS, C. Board, REC AMP C. Board, Meter Bracket	7
101	SBSB3008Z	"	Handle Bracket	2
102	SBSB3010Z	"	Mecha. Counter Bracket	2
103	SBSB3010C	"	Top Panel	11
104	SBSB30R	"	Bottom Cover	5
106	SSBP3008N	Screw	Tapping Plate	8
107	SSSP3006ZS	"	Counter	2
108	DPSP3008ZS	"	Power Transformer	2
109	SHBP3006RS	"	Reed Switch, Cover	8

Ref. No.	Parts No.	Part Name	Remarks	Q'ty
110	SHBP4020RS	Screw	Front Panel	4
111	WBS2600Z	Teeth Washer		1
112	WNB2600	Washer	Rubber Bushing	2
113	REE4000	"E" Ring	Button Shaft	2
114	SBSB3012Z	Tapping Screw	Bracket	2
115	TAS336511-01	Shield Board	REC AMP C. Board	1
116	TJN336512	Lid Spacer		2
117	TJN336522	Lid Cushion		1
118	SBSB3020R	Tapping Screw		1
119	THS000489-01	Head Label		1
120	TFW336518-01	Wire Holder		1
121	TFB336516-01	Bracket		1
122	TJN294414-01	Cushion		1
123	TFB350401-01	Fuse Holder Bracket	KD-2J/C	1
124	OMG1121-004	Fuse Holder	KD-2J/C	1
125	QMG1321-002	"	KD-2E/B/A	2
	QMF61U1-1R0	Fuse	KD-2J/C	1
	QMF51A2-1R0	"	KD-2E/B/A	1
	QMF51A2-R80	"		1
126	SBSB3006Z	Screw	KD-2J/C	2
127	LPSP3006ZS	"	"	1
128	TAZ000445-01	Fuse Seal (1.0AT)	KD-2J/C/E/B/A	1
	TAZ000445-06	Fuse Seal (800mAT)	KD-2E/B/A	1
129	TLT000480-02	Caution Seal	KD-2J/C for Fuse Replacement	1
130	SBSB3006Z	Screw	KD-2E/B/A	2
131	QSS2325-007	Slide Switch	KD-2E/B/A Voltage Select	1
	QSS2325-009	"	KD-2U	1
132	SBSB3008Z	Screw	KD-2E/B/A/U	2
140		UL Label		1
A	ZCKD2Y-CBT-1	Top Panel Ass'y	Ref. No. 1,2,3,4,7	1 set
B	ZCKD2Y-CBF	Front Panel Ass'y	Ref. No. 8,9,11,12,13,14	"
C	ZCKD2Y-BCA	Battery Cover Ass'y	Ref. No. 20,21	"
D	ZCKD2Y-CBT-2	Cover Ass'y	Ref. No. 15, 16	"
E	ZCKD2Y-CBR	Bottom Cover Ass'y	Ref. No. 18,19,37	"

Wiring

KD-2J/C

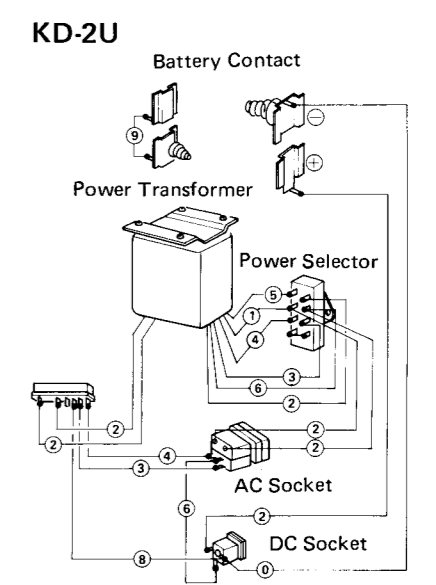
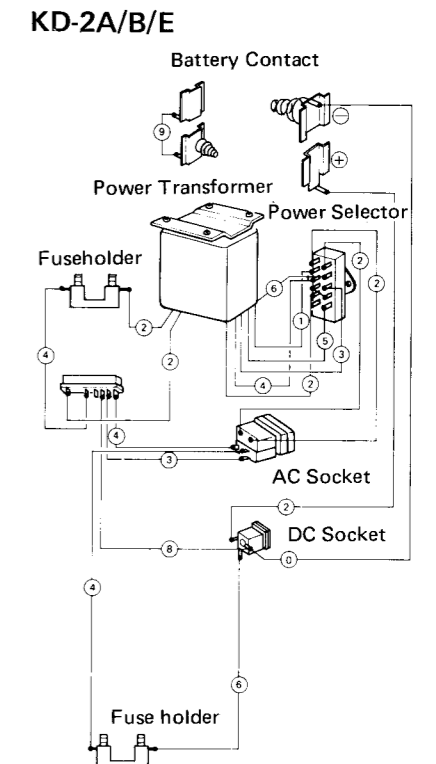
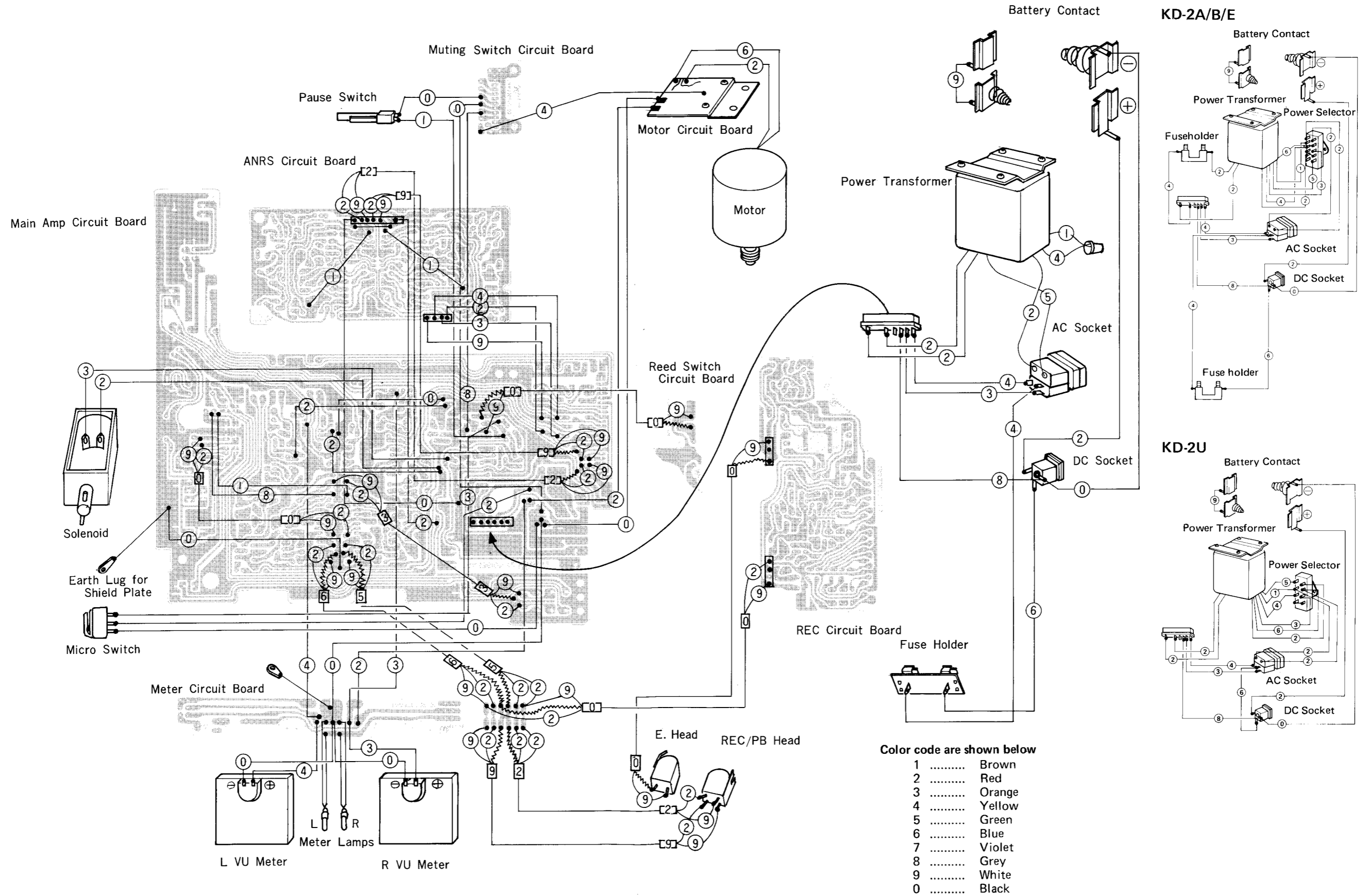

- Color code are shown below
- 1 Brown
 - 2 Red
 - 3 Orange
 - 4 Yellow
 - 5 Green
 - 6 Blue
 - 7 Violet
 - 8 Grey
 - 9 White
 - 0 Black

Fig. 18

Standard Schematic Diagram

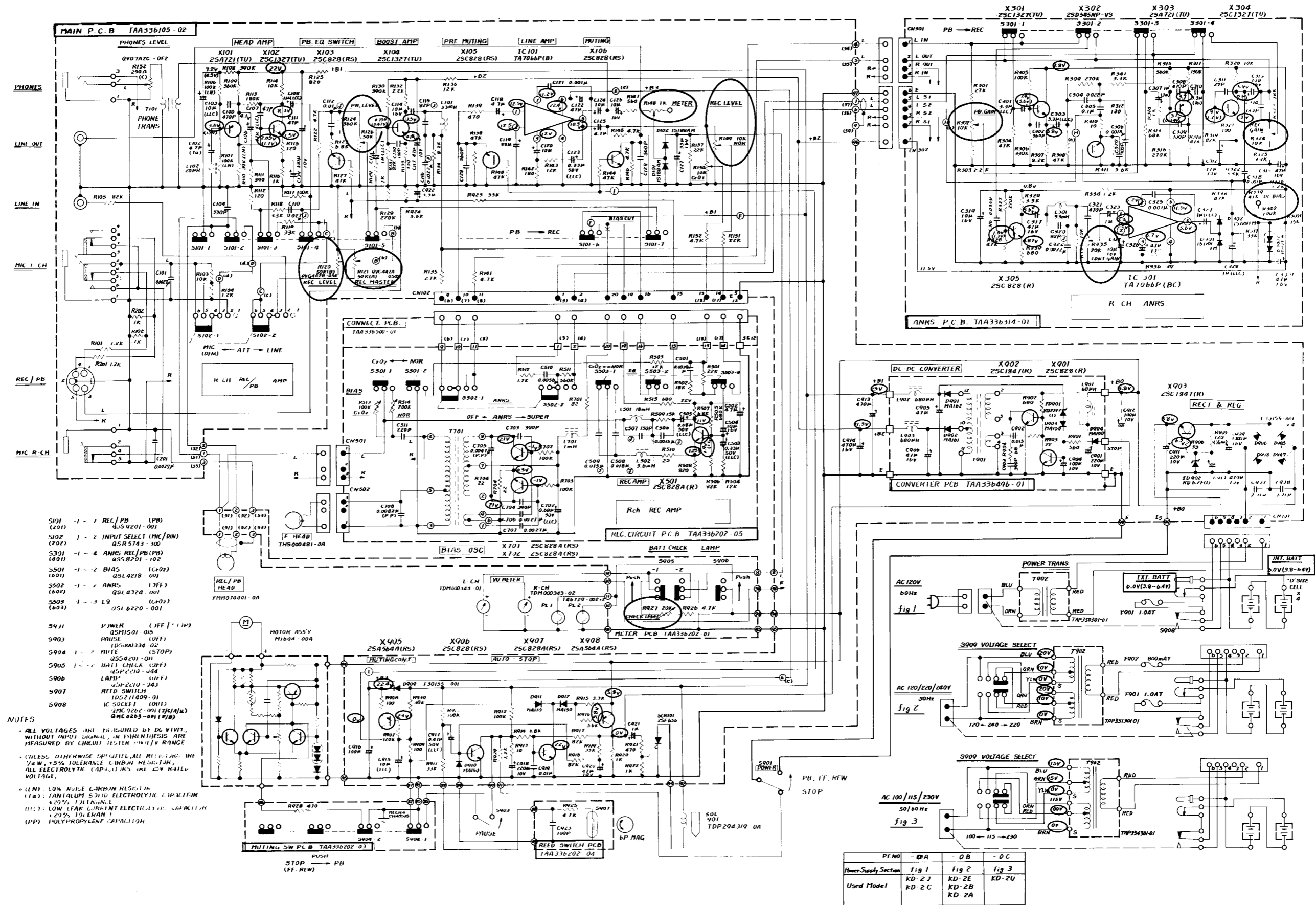

Fig. 19

Accessories

Parts No.	Parts Name	Remarks	Q'ty
T30046-00B	Pin Cord Ass'y	KD-2J/C/A/U	2
CN-201	Din Cord Ass'y	KD-2E/B	1
QMP1240-183	Power Cord Ass'y	KD-2J/C	1
QMP3950-183	"	KD-2E	1
QMP9017-006BS	"	KD-2B	1
QMP2540-183	"	KD-2A	1
QMP7640-183	"	KD-2U	1
TLC336310-0A	Belt Ass'y		1
T46965-002	Demo Cassette		1
T47796-00B	Head Cleaning Stick		1
AP4056A-24	Envelope	for Head Cleaning Stick	1
TLT000429-01	Caution Card	"	1
TLT350302-01	"	for Belt Ass'y	1
TLT350303-01	"	for Cassette Cover	1
T7646EGF	Instruction Book		1
TLJ000476-02	ANRS Seal		1
TLJ000477-02	Super ANRS Seal		1
TLZ000348-02	Tape Selector Chart		1
BT20032	Warranty Card	KD-2J	1
BT20025	"	KD-2C	1
BT20029	"	KD-2A	1
BT20015	"	DK-2U (for PX KANAZAWA)	1
BT20013	Garranty Certificate	KD-2B	1
BT20023	Service Procedure	KD-2J	1
BT20024B	Special Replay Card	KD-2J	1
TLT052401-01	Warning Label	KD-2E/B/A (Disconnect P. Cord)	1
T46328-004	Caution Card	KD-2E (for Voltage Select)	1
T46328-003	"	KD-2B/A (")	1
T46328-001	"	KD-2U (")	1
QZL1002-003BS	Warning Label	KD-2B (for P. Cord)	1
TJL000443-01	Seal	KD-2B (made in Japan)	1
E7795-1	E. P Mark	KD-2U (for PX KANAZAWA)	1
E04056-001	Conti. Plug	KD-2U (for Sansei)	1
TLT279401-01	Caution Card	KD-2E (for France)	1

Packing

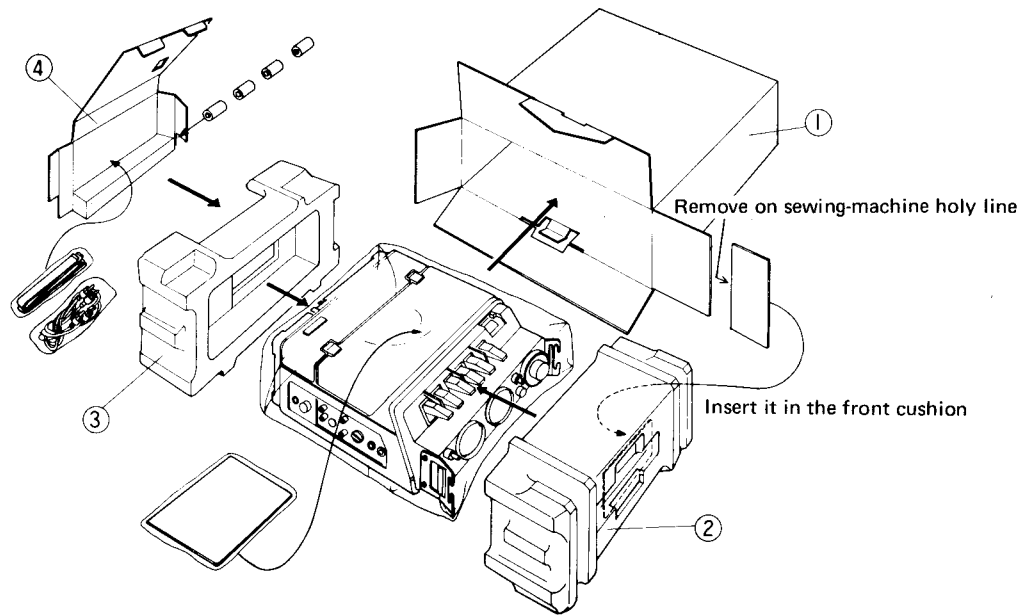

Fig. 20

Packing List

Ref. No.	Part No.	Part Name	Rema.ks	Q'ty
1~4	TKB336316-0B	Packing Ass'y	KD-2JE/B/U/A	1 set
	TKB336316-0C	"	KD-2C	1
2	TKC336106-01	Cushion		1
3	TKC336107-01	"		1
4	TKB336316-02	Case	for Accessories	1
1	TKB336316-06	"	KD-2J/E/B/U/A	1
	TKB336316-07	"	KD-2C	1
	TKB336316-05	Spacer		1
	T6800-00R	Envelope	for Set	1
	AP4056A-046	"	for Powercord	1
	AP4056A-077	"	for Instruction Book	1

JVC

VICTOR COMPANY OF JAPAN, LIMITED
 RADIO & RECORDING MACHINE DIVISION 804 Futoo-cho, Kohoku-ku, Yokohama, Japan