

JVC

SERVICE MANUAL

MODEL
L-A11
AUTO-RETURN
TURNTABLE



No. 2461
November, 1978

Contents

	Pages
1. Specifications	2
2. "How to Operate" (Names and Functions).	3
3. Operation of Automatic Mechanism	3
4. Cartridge Replacement	4
5. Adjustment Procedures	
5-(1) Overhang Adjustment.	5
5-(2) Headshell Anglo Adjustment	5
5-(3) Tonearm Lifter Height Adjustment.	5
5-(4) Auto-return (Lead-out) Adjustment	5
5-(5) Tracking Force Adjustment.	5
5-(6) Anti-skating Adjustment.	6
5-(7) Pulley Height Adjustment	6
6. Lubrication	6
7. Exploded Views and Parts List	
7-(1) Mechanism Assembly	7
7-(2) Cabinet Assembly	9
7-(3) Tonearm Assembly	10
7-(4) Mechanism Base and Motor Assembly	10
7-(5) Parts List with Specified Numbers for Designated Areas	11
8. Packing Materials and Part Numbers	12
9. Accessories List.	13
10. L-A11 Schematic Diagrams for Designated Areas	14

Warning: When replacing the parts marked with  , be sure to use the designated parts to ensure safety.

CHECKING YOUR LINE VOLTAGE (For U.S. Military Market and Other Countries)

Before inserting the power plug, please check this setting to see that it corresponds with the line voltage in your area. If it doesn't, be sure to adjust the voltage selector switch to the proper setting before operating this equipment. The voltage selector switch is located the inside chassis.

1. Specifications

MOTOR AND TURNTABLE

Drive System: Belt drive system
 Drive Motor: 4 poles synchronous motor
 Speeds: 33-1/3 and 45 rpm
 Wow and Flutter: Less than 0.06% (WRMS)
 Signal to Noise Ratio: Better than 63dB (DIN-B)
 Platter: 12-inch(30cm) diameter die-cast aluminium alloy

TONARM

Type: Statically-balanced S-shaped tubular arm with tracking force dial of 0.1 gram steps
 Effective Arm Length: 220mm
 Overhang: 15mm
 Applicable Tracking Force Range: 0 to 3 grams

CARTRIDGE

Type: Moving magnet (MD-1025)
 Stylus: 0.5mil, diamond
 Model DT-Z1S

Optimum Tracking

Force: 1.5 to 2.0 grams (DT-Z1S)
 Output: 3mV (1kHz)
 Frequency Responce: 10 to 25,000Hz
 Separation: Better than 25dB (1kHz)
 Load Resistance: 47k to 100kohms
 Compliance: 25×10^{-6} cm/dyne

FEATURES

Tonearm lifter, Auto-return mechanism, Removable dust cover, Anti-skating device, etc.

GENERAL

Power Source: Refer to Table shown below
 Power Consumption: Refer to Table shown below
 Dimensions: 43.8(W) x 38.0(D) x 143(H)
 (17 1/4 x 14 16/64 x 5 5/8)
 Weight: 4.5kg (9.9 lbs)

POWER SPECIFICATIONS

Countries	Line Voltage & Frequency	Power Consumption
U.S.A., CANADA	AC 120V, 60Hz	13 watts
EUROPE CONTINENT	AC 220V~, 50Hz	13 watts
U.K., AUSTRALIA	AC 240V~, 50Hz	13 watts
U.S. MILITARY MARKET	AC 110~120V/220~240V Selectable, 50/60Hz	13 watts
OTHER AREAS	AC 110~120V/220~240V Selectable, 50/60Hz	13 watts

2. "How to Operate" (Names and Functions)

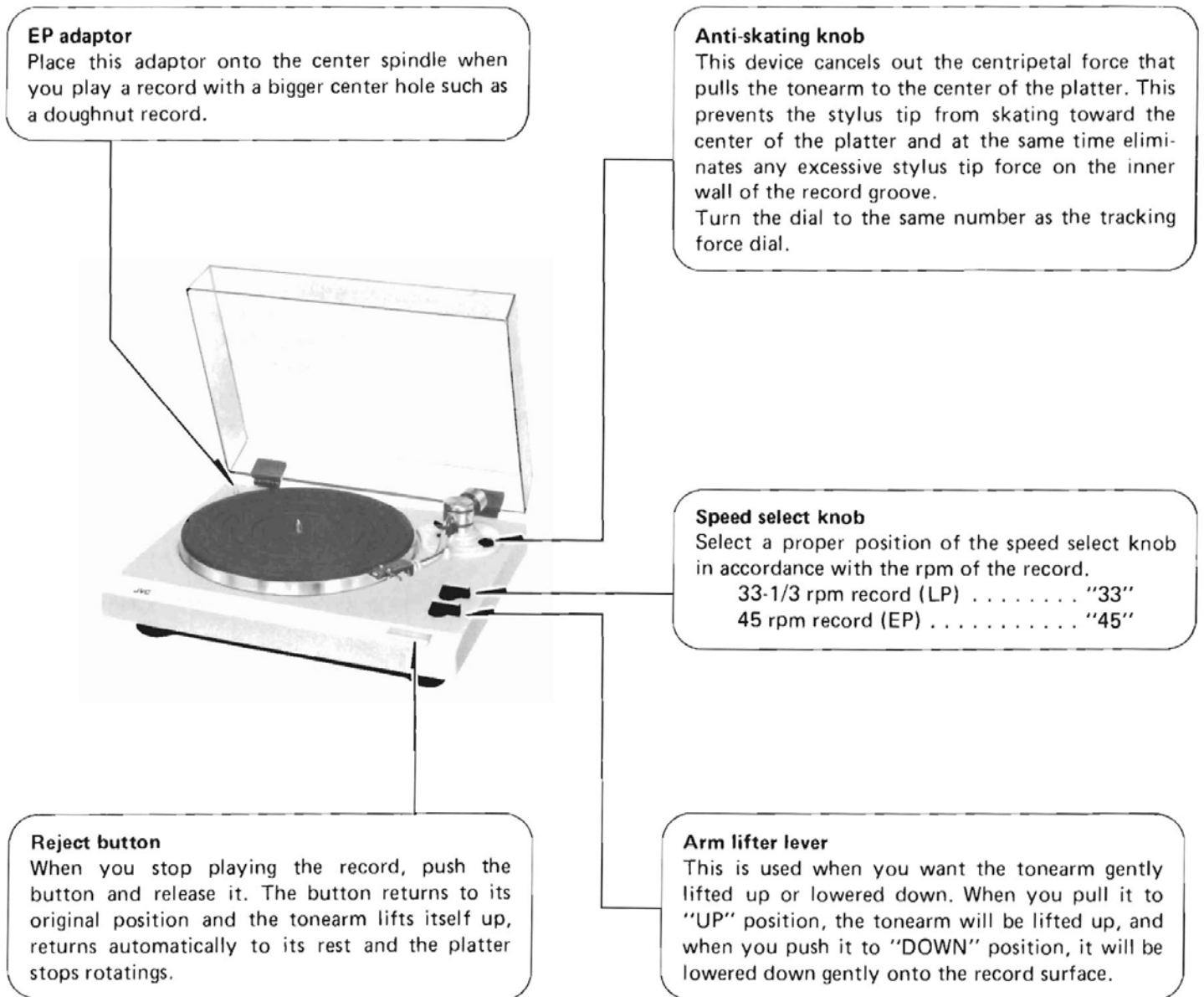

Fig. 1

3. Operation of Automatic Mechanism

Change cycle mechanism:

1. During playing, the notch of the main gear position relative to the turntable spindle gear is as shown in Fig. 2.
2. As the projection is away from the engagement, the main gear does not rotate even though the turntable.
2. As playing proceeds, the trip slide moves toward the center of the turntable following the movement of the tonearm.
3. The engagement is very easy to move as it simply rests on the lower trip. On the music section of the record groove the engagement moves so slightly that it is returned by the tip of the projection. Consequently, the turntable spindle gear does not engage with the main gear and thus does not trigger the auto-return operation as shown in Fig. 3.

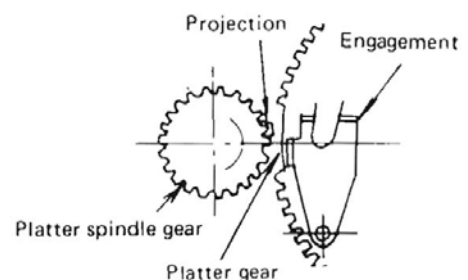

Fig. 2

- When playing ends and the pick-up cartridge enters the lead-out groove which is spaced out, the engagement advances more than it is returned by the projection. Because of this, the engagement is pressed by the projection as shown in Fig. 4, causing the main gear to turn and engage with the turntable spindle gear. Thus the change cycle is started.
- During the return operation the engagement and lower trip which have moved are returned to their original position by the reject button coming into contact with the bottom of the lower trip. At this moment the switch lever operates with the help of the main gear cam, switching off the power just before the rotation should stop. This completes the automatic cycle.

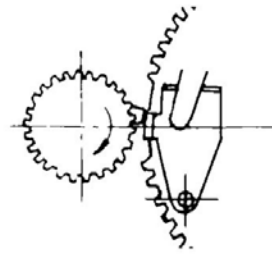

Fig. 3

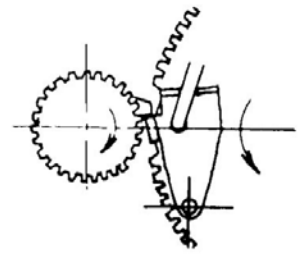

Fig. 4

Tonearm lift and return mechanism:

- When the main gear starts to rotate at the end of playing, the return lever rotates under the action of the main gear cam to press the elevator cam. The upward movement of the elevator cam is directly converted into movement of the elevator, lifting up the tonearm. (Fig. 5)
- The tonearm is returned by the arm lever the end of which presses it as the main gear rotates. (Fig. 6)

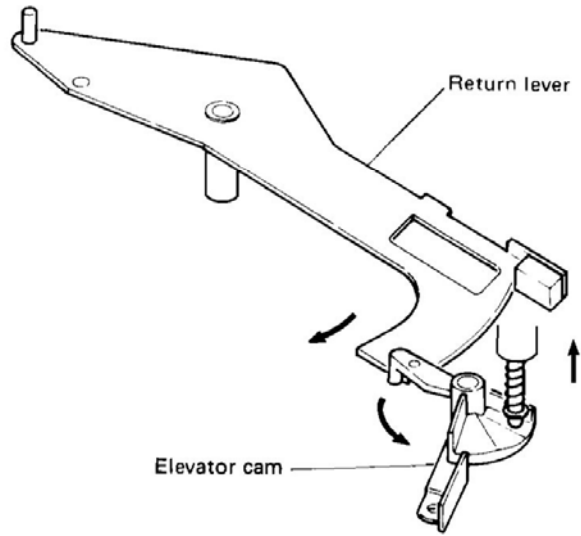

Fig. 5

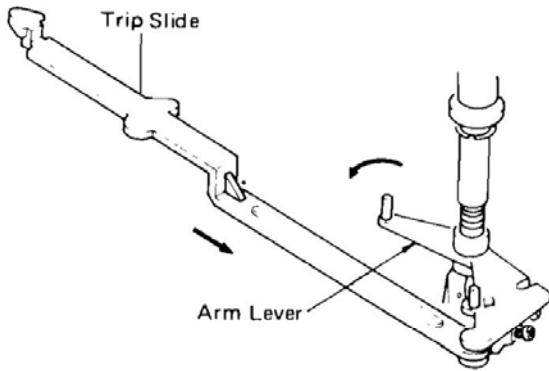

Fig. 6

4. Cartridge Replacement

- Unscrew the connector nut to remove the headshell.
- Remove the two long screws on the headshell which hold the cartridge.
- Connect the lead wires of the headshell to the new cartridge, being careful to match the polarities correctly. Polarity and wire colors are as follows:
 White (+) L Red (+) R
 Blue (-) LE Green (-) RE
- Attach the cartridge to the headshell squarely, and gently tighten the screws.
- Set the cueing lever to "DOWN", and then bring the stylus tip to the optimum position by sliding the cartridge back and forth. See 5-(1) Overhang Adjustment
- After attaching the cartridge, slide the headshell into the tonearm with the connector pin fitting in the groove. Tighten the connector nut.

- Be sure to adjust the tracking force and lead-in position after replacing the cartridge.

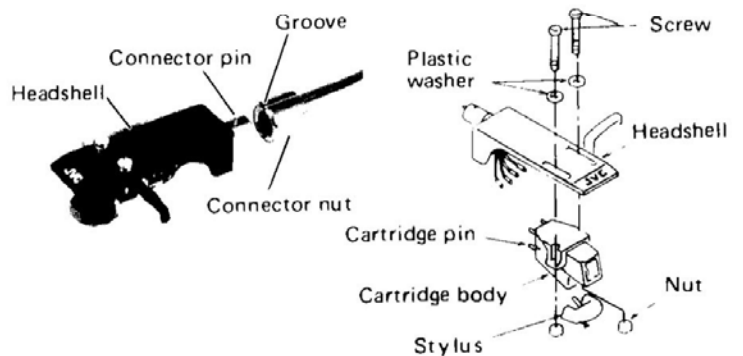

Fig. 7

5. Adjustment Procedures

The following adjustments should be performed only when replacing a cartridge or a headshell.

Otherwise, no adjustment is required.

If necessary to replace a cartridge, usage of that headshell exclusive to this unit is recommended.

5-(1) Overhang Adjustment

To obtain optimum overhang, when mounting the cartridge, first align the cartridge's longitudinal axis with that of the headshell and position the cartridge so that the distance between the headshell's end face and the stylus tip equals 48mm as shown in Fig. 8-A.

Be sure to tighten the set screw after the adjustment. Errors within 1mm are negligible from a practical point of view.

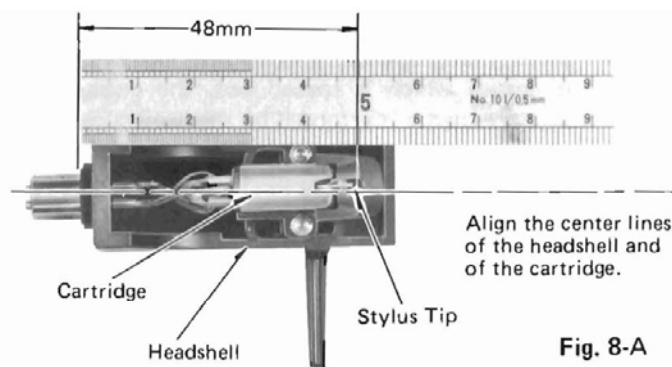

Fig. 8-A

5-(2) Headshell Angle Adjustment

If the headshell is not horizontal and the stylus tip is not perpendicular to the record surface, loosen the lock screws using a small screwdriver and adjust the headshell until the stylus tip is set at a right angle as shown in Fig. 8-B. Eye measurement is sufficient.

Be sure to retighten the screws after the adjustment is completed.

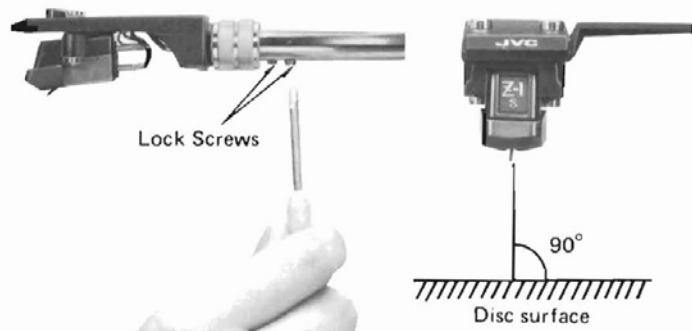

Fig. 8-B

5-(3) Tonearm Lifter Height Adjustment

Adjust the height of tonearm lifter with the adjustment screw so that the distance between the stylus tip and the surface of record is about 6mm when the stylus is elevated. Turn the height adjustment screw clockwise to lower, and counterclockwise to raise the tonearm lifter level. (See Fig. 9.)

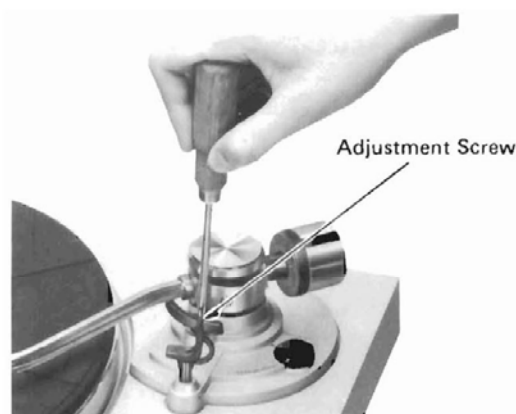

Fig. 9

5-(4) Auto-return (Lead-out) Adjustment

When the pulley has been replaced for a different record or if auto-return functions early, adjust as shown in Fig. 10

– When change cycle starts too late, turn the screw counterclockwise with a phillips screwdriver.

– When change cycle starts too early, turn the screw clockwise.

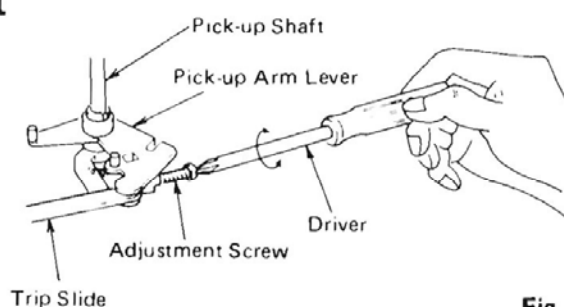

Fig. 10

5-(5) Tracking Force Adjustment

1. Set the anti-skating knob to the "0" mark on the dial.
2. Place an unwarped disc onto the platter.
3. Remove the stylus cover from the stylus.
4. Release the tonearm clamp.
5. Turn the counterweight until the tonearm is balanced.
6. Stop turning the counterweight when the stylus tip is almost touching the disc surface.

7. Return the tonearm to the rest and clamp it.
8. Hold the counterweight at the adjusted position and turn the tracking force dial until the "0" mark is aligned with the index line on the tonearm weight shaft. Turn the counterweight in the A direction until the "2" mark on the dial is aligned with the index line for the model preparing cartridge Z-1S except U.S.A., Canada and U.K. See Fig. 11

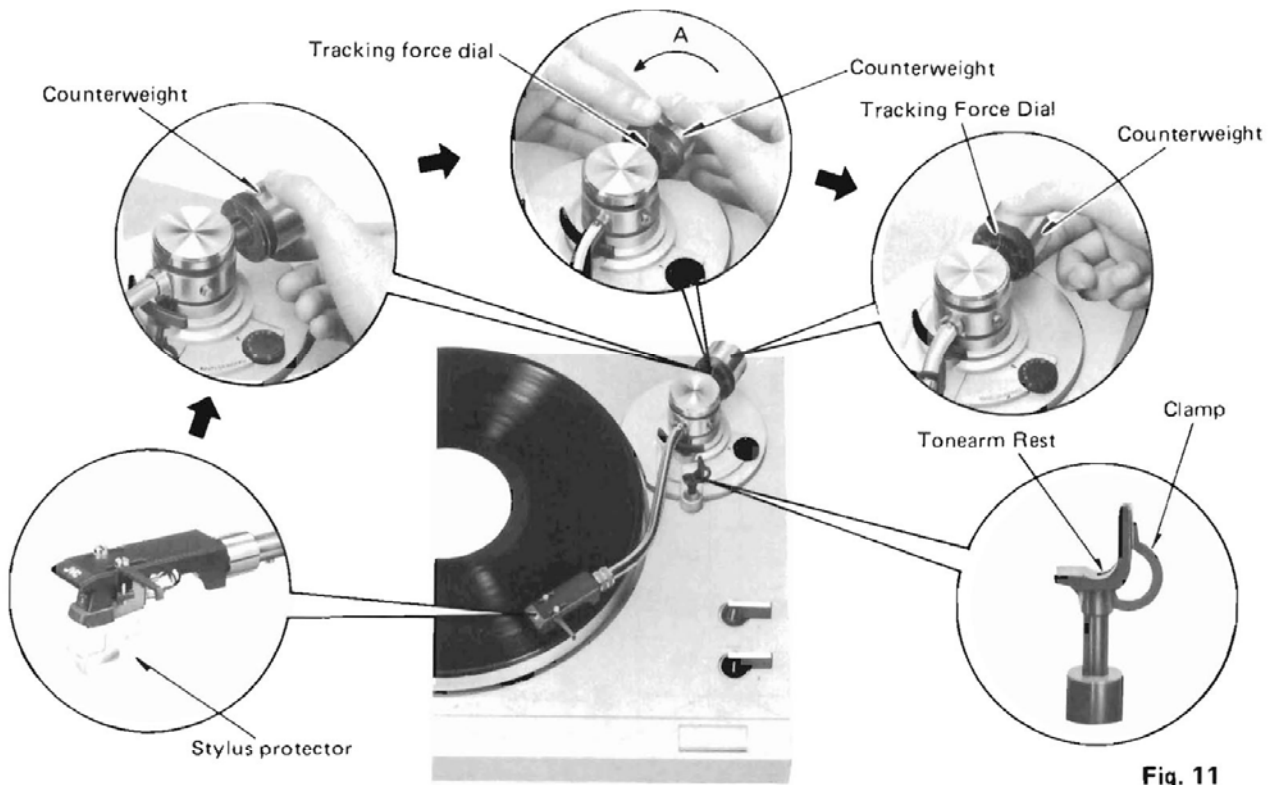

Fig. 11

5-(6) Anti-skating Adjustment

Adjust the anti-skating force according to the cartridge used. Turn the anti-skating knob dial to the same number on the tracking force dial.

Set the "2" of the Knob dial to the index Arrow since the L-A11 is provided with a spherical stylus except U.S.A., Canada and U.K. and the tracking force has been adjusted to 2 g.

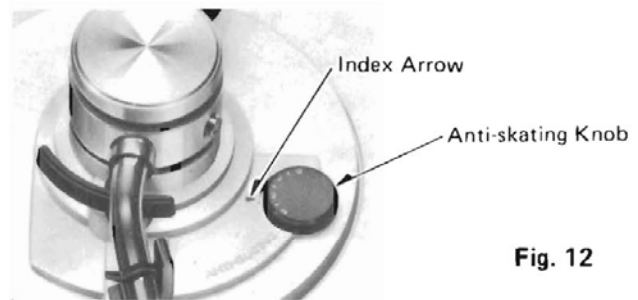

Fig. 12

5-(7) Pulley Height Adjustment

When the pulley has been replaced for a different frequency, adjust the height of the pulley so that the belt is located in the middle of each section. If this is not done its correct speeds cannot be obtained and the speed change will not be smooth.

If the belt is in contact with the shift lever, the height of the pulley is not correct. Loosen the set screw and adjust the pulley vertically. (Fig. 13)

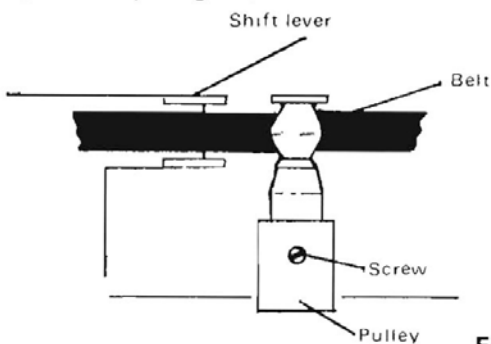

Fig. 13

6. Lubrication

Use quality mineral oil such as sewing machine oil on the motor shaft and turntable spindle.

* Motor shaft

5 - 6 drops once a month for heavy use

1 - 2 drops every three months for normal home use.

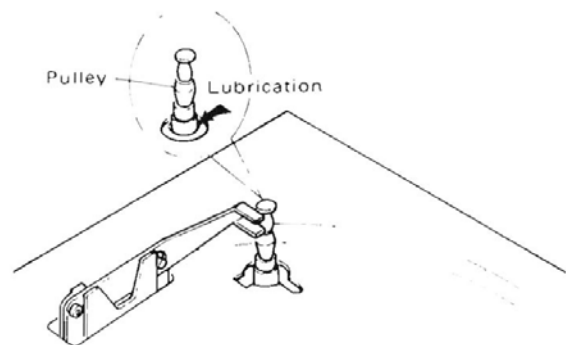

Fig. 14

7. Exploded Views and Parts List

7-(1) Mechanism Assembly

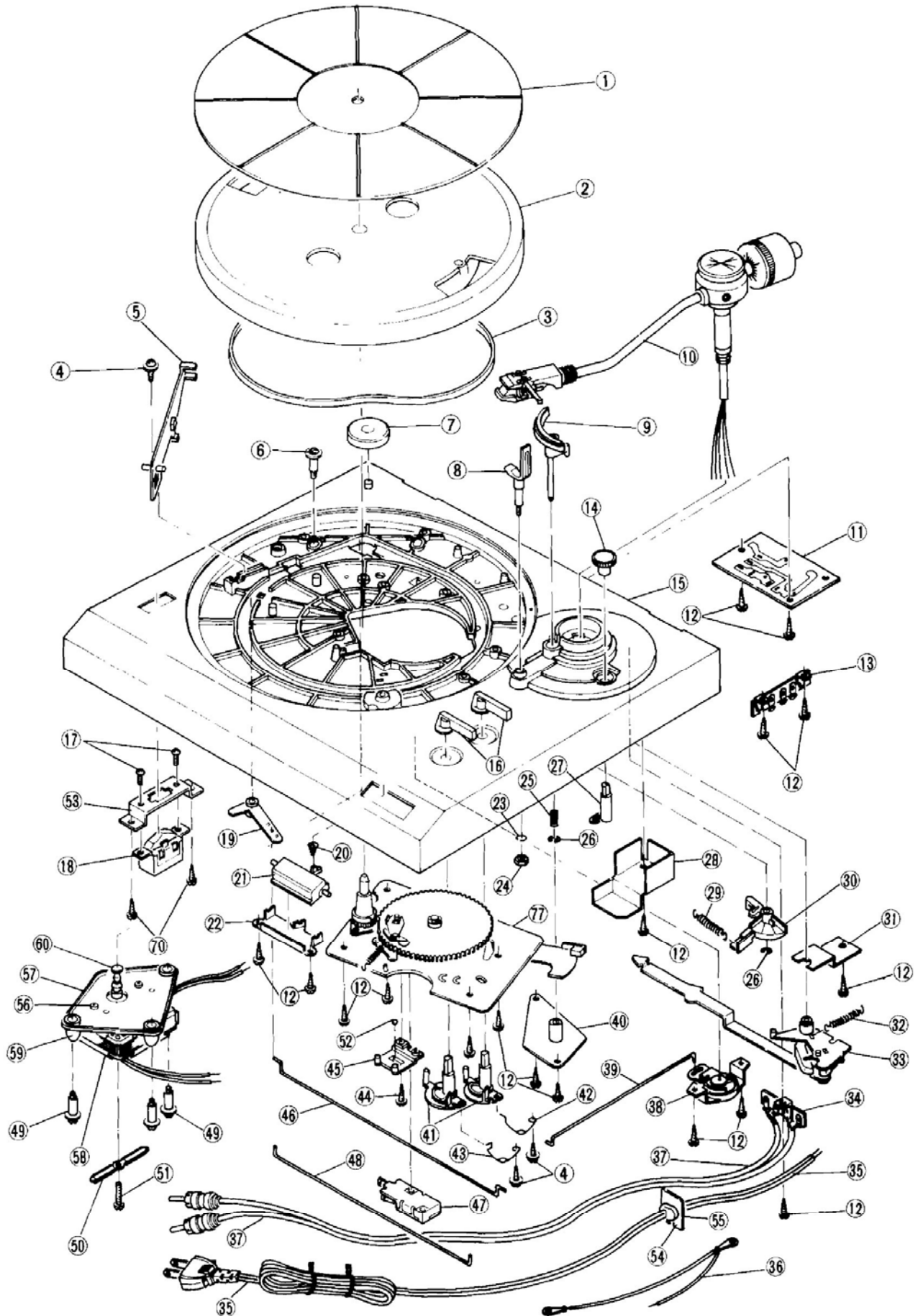









Fig. 15

Parts List

Item No.	Part Number	Description
1	*See page 11	Platter Covering
2	E1971-005	Turntable
3	G30005	Belt
4	E65922-002	Tapping Screw
5	E61473-001	Shifter
6	E49633-003	Motor Holder
7	E48820-001	E.P. Adaptor
8	E60982-002	Arm-rest Ass'y
9	E61472-003	Elevator Ass'y
10	*See page 11	Tonearm Ass'y
11	"	P.C. Board Ass'y 
12	E65921-002	Tapping Screw
13	*See page 11	Lug Strip Ass'y (3 pins) 
14	E35864-001	Antiskating Knob
15	*See page 11	Cabinet
16	E35865-001	Cueing Knob
17	*See page 11	Screw
18	*See page 11	Seesaw Switch 
19	E61094-002	Shift Lever
20	E65777-001	Spring
21	E35863-001	Pushbutton
22	E65771-001	Bracket
23	WLS4000N	Washer
24	NTB4000BS	Nut
25	E61194-002	Spring
26	REE3000	"E" Ring
27	E65775-001	Antiskating Shaft
28	E35866-001	Shield Cover
29	E49596-001	Spring
30	E49595-003	Elevator Cam
31	E65289-001	Stopper

Item No.	Part Number	Description
32	E65774-002	Antiskating Spring
33	E33896-004	Arm Lever Ass'y
34	QML1310-041	Lug Strip Ass'y (4 pins)
35	*See page 11	Power Cord 
36	EWT042-002	Terminal Wire Ass'y
37	E03697-003	Signal Cord
38	E65956-002	Cueing Ass'y
39	E65772-001	Cueing Rod
40	E65767-001	Cueing Base Ass'y
41	E35862-001	Knob Shaft
42	E65776-001	Spring
43	E49608-002	Spring
44	SBSB3008Z	Tapping Screw
45	E49873-002	Steel Ball Holder
46	E35867-001	Speed Rod
47	*See page 11	Micro Switch 
48	E65773-001	Reject Rod
49	E61530-001	Motor Holder
50	*See page 11	Wire Clamp
51	SBSB3508N	Tapping Screw
52	G41505-1	Steel Ball
53	*See page 11	Switch Bracket
54	*See page 11	Cord Stopper 
55	*See page 11	Cord Stopper Plate
56	LPSP3008ZS	Screw
57	E61096-001	Mounting Plate
58	*See page 11	Motor 
59	E49631-003	Rubber Bushing
60	*See page 11	Pulley
61	*See page 11	Tapping Screw
77	See page 10	7-(4) Mechanism Base Ass'y

 : Safety Parts

*Different in different area, see page 11

7-(2) Cabinet Assembly

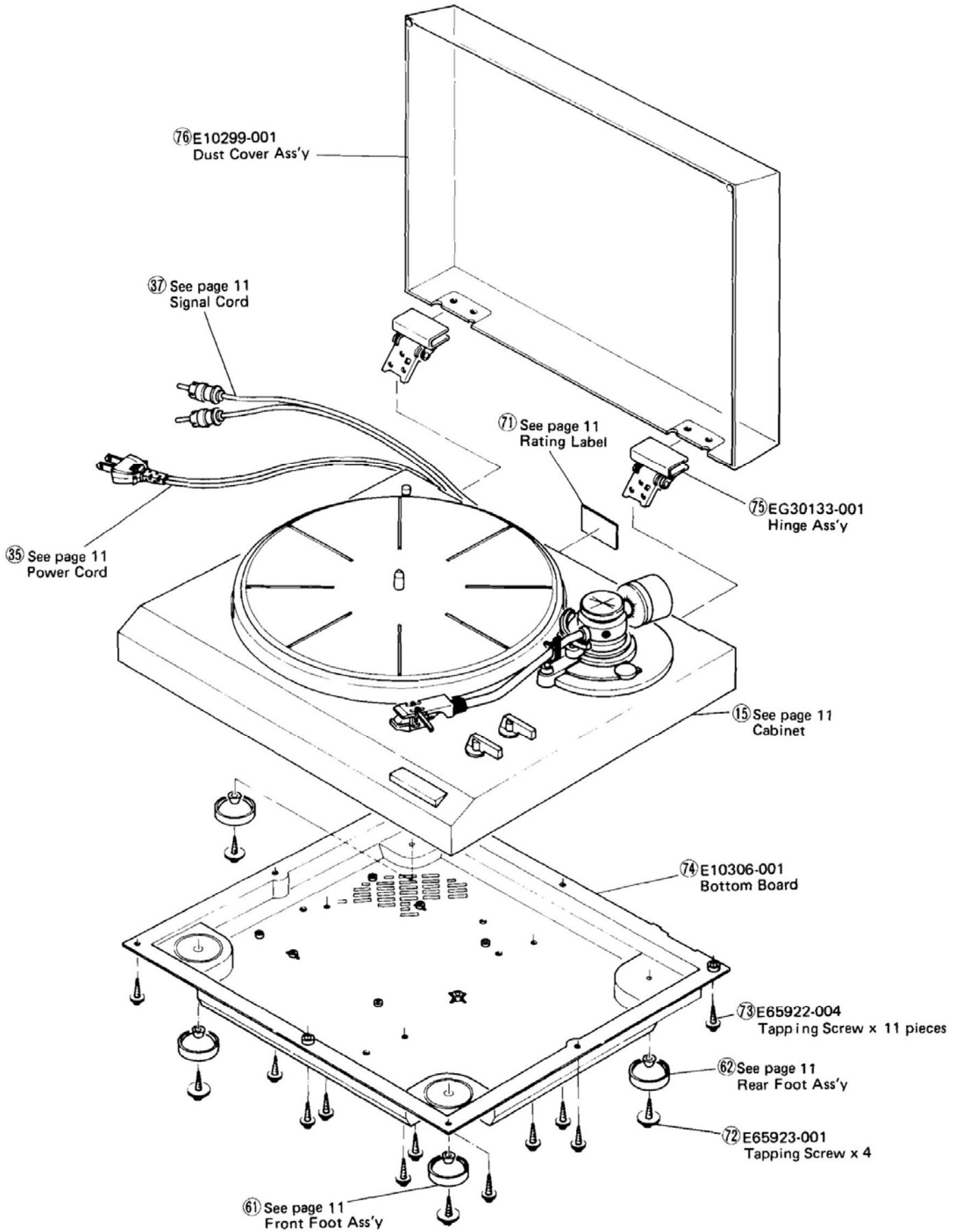

Fig. 16

7-(3) Tonearm Assembly

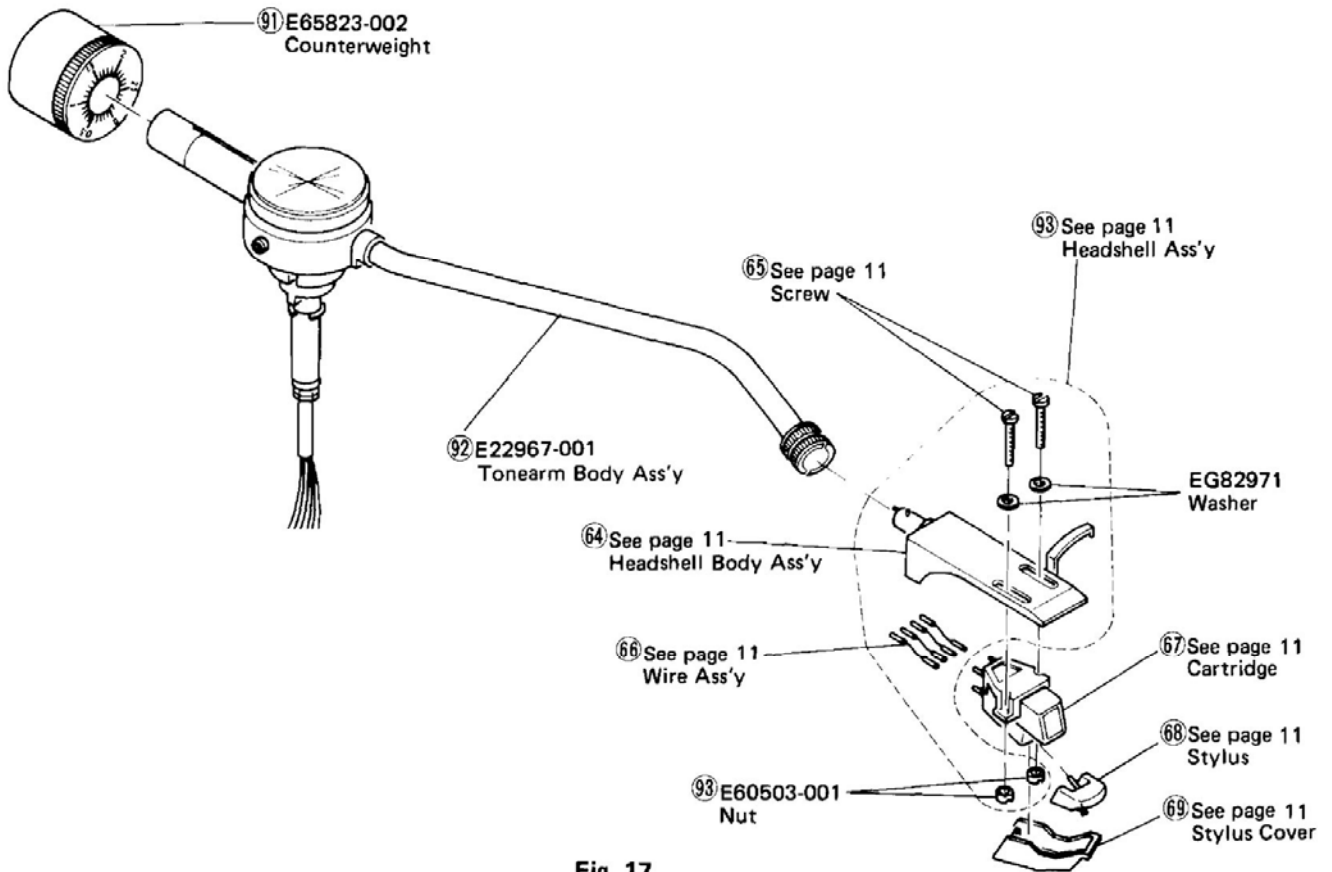

Fig. 17

7-(4) Mechanism Base and Motor Assembly

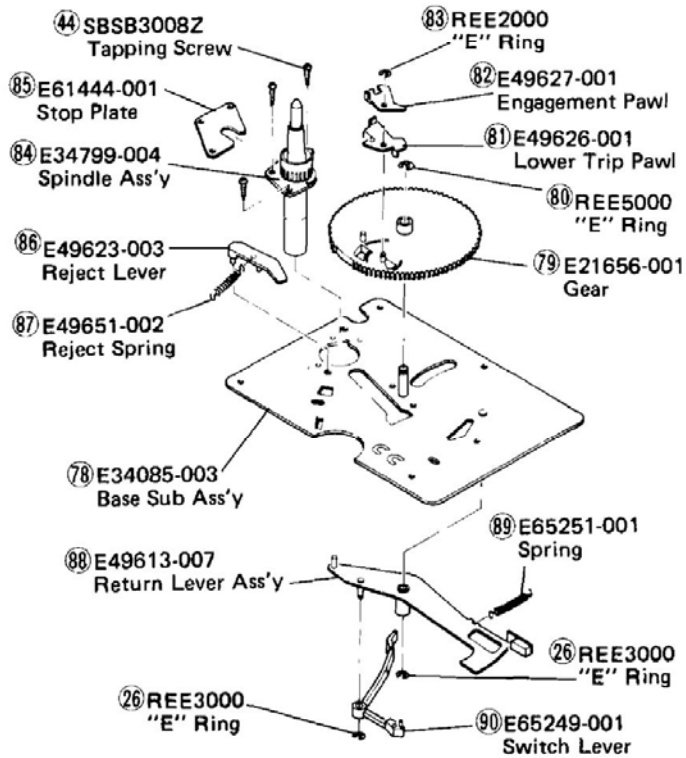

Fig. 18

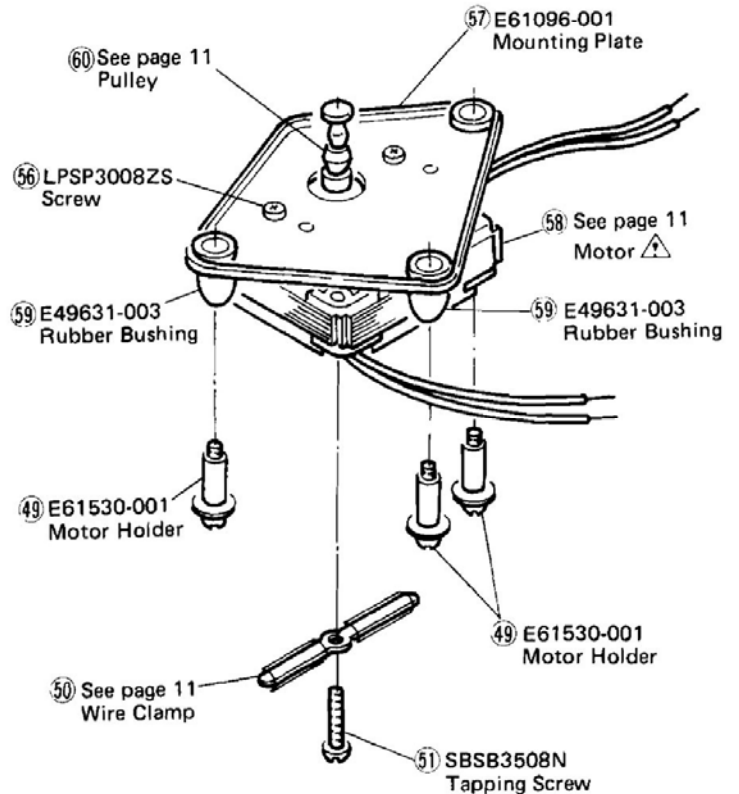

Fig. 19

7-(5) Parts List with Specified Numbers for Designated Areas

Item No.	Description	U.S.A. & Canada	U.K.	Australia	Europe	U.S. Military Market & Other Countries
1	Platter Covering	E22719-002	E22362-001	E22362-001	E22362-001	E22362-001
10	Tonearm Ass'y	ARM-527	ARM-528	MP-200S	MP-200S	MP-200S
11	P.C. Board Ass'y \triangle	_____	TPS-207ABS	TPS-207B	TPS-207B	TPS-208
C101	Capacitor \triangle	QFH72BM-473 (U.S.A. 0.047 μ F/ AC 125V) QFA72BM-473M (Canada 0.047 μ F/ AC 125V)	QFZ9007-473BS (0.047 μ F/ AC 450V)	QFZ9007-473 (0.047 μ F/ AC 450V)	QFZ9007-473 (0.047 μ F/ AC 450V)	QFH53BM-473 (0.047 μ F/AC 1kV)
13	Lug Strip Ass'y \triangle	E65274-002	_____	_____	_____	_____
15	Cabinet	E10307-001	E10307-002	E10307-001	E10307-001	E10307-001
17	Screw	_____	SSSP3006NS	_____	_____	_____
18	Seesaw Switch \triangle	_____	QSE2235-203BS	_____	_____	_____
35	Power Cord \triangle	QMP1200-200	QMP9017-008BS	QMP2500-200	QMP3900-200	QMP1200-200
47	Micro Switch \triangle	QSM1V01-018	QSM1V12-102BS	QSM1V12-102	QSM1V12-102	QSM1V01-018
50	Wire Clamp	E50670-005	E50670-005	E50670-005	E50670-005	E47203-004
53	Switch Bracket	_____	E61157-002	_____	_____	_____
54	Cord Stopper \triangle	QHS3876-162	A37897BS	A37897	A37897	A37897
55	Cord Stopper Plate	E65465-001	_____	_____	_____	_____
58	Motor \triangle	M712L	M712MBS	M712M	M712M	M712B
60	Pulley (50Hz)	_____	E60962-001	E60962-001	E60962-001	E60962-001
	" (60Hz)	E60962-002	_____	_____	_____	E60962-002
61	Front Foot Ass'y	E35857-003 (Gray)	E35857-004 (Blue)	E35857-004 (Blue)	E35857-004 (Blue)	E35857-004 (Blue)
62	Rear Foot Ass'y	E35857-001 (Black)	E35857-002 (Brown)	E35857-002 (Brown)	E35857-002 (Brown)	E35857-002 (Brown)
63	Headshell Ass'y	E34972-001	E34991-002	E34972-001	E34972-001	E34972-001
64	Headshell Body	E34971-001	E34990-002	E34971-001	E34971-001	E34971-001
65	Screw	E60502-004	E61844-001	E60502-001	E60502-001	E60502-001
66	Lead Wire Ass'y	E60501-007	E60501-001	E60501-007	E60501-007	E60501-007
67	Cartridge	_____	_____	MD1025	MD1025	MD1025
68	Stylus	_____	_____	DT-Z1S	DT-Z1S	DT-Z1S
69	Stylus Cover	_____	_____	E34268-001	E34268-001	E34268-001
70	Tapping Screw	_____	E65921-001	_____	_____	_____
71	Rating Label	E35064-016	E35339-032BS	E35339-031	E35339-030	E35339-029 (U.S. Military) E35339-028 (Other Countries)

NOTE \triangle : SAFETY PARTS

8. Packing Materials and Part Numbers

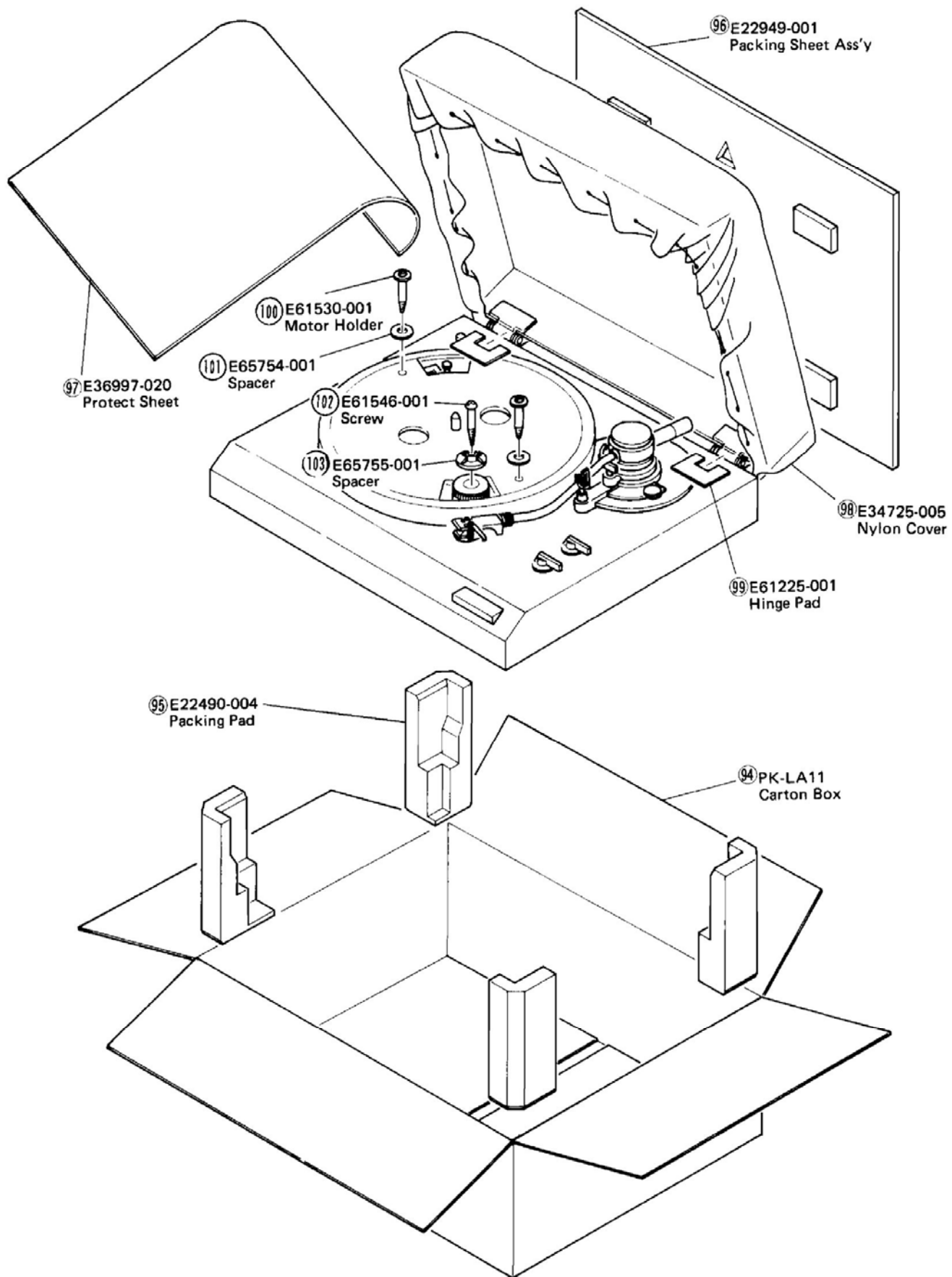

Fig. 20

9. Accessories List

Item No.	Description	U.S.A. & Canada	U.K.	Australia	Europe	U.S. Military Market & Other Countries
1	Instruction Book	E30580-715A (in English) E30580-716A (in German & French)	E30580-715A	E30580-715A	E30580-715A (in English) E30580-716A (in German & French)	E30580-715A
2	Warranty Card	BT20032 (U.S.A.) BT20025C (Canada)	BT20013B	BT20029	_____	BT20032 (U.S. Military)
3	Special Reply Card	BT20024B (U.S.A.)	_____	_____	_____	BT20024B (U.S. Military)
4	Service Procedure	BT20023 (U.S.A.)	_____	_____	_____	BT20023 (U.S. Military)
5	Envelope (Instruction Book & Warranty Card)	E41202-2	E41202-2	E41202-2	E41202-2	E41202-2
6	E.P. Adaptor	E48820-001	E48820-001	E48820-001	E48820-001	E48820-001
7	Screwdriver	_____	_____	_____	_____	E45557-003
8	Siemens Plug	_____	_____	_____	_____	E04056 (Other Countries)

10. L-A11 Schematic Diagrams for Designated Areas

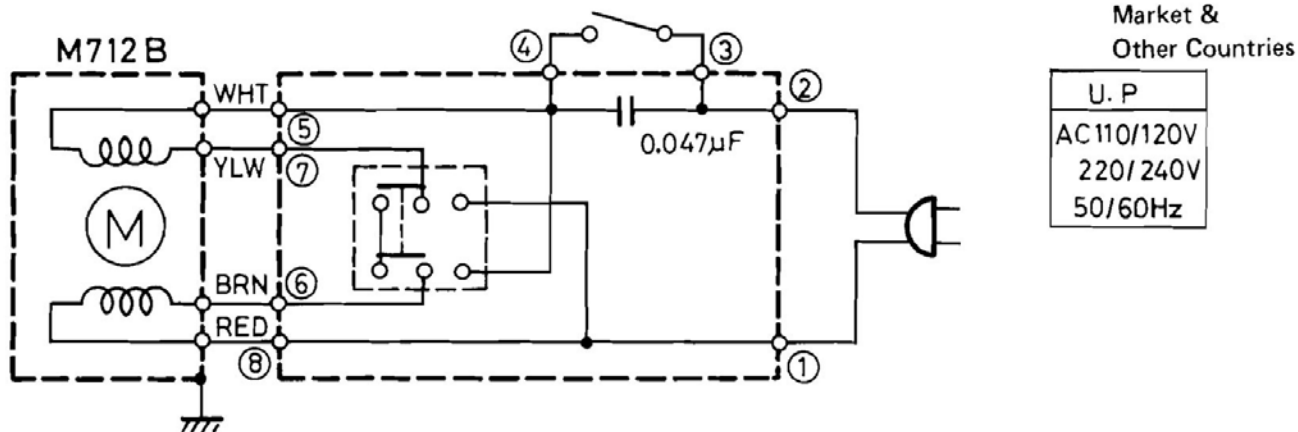
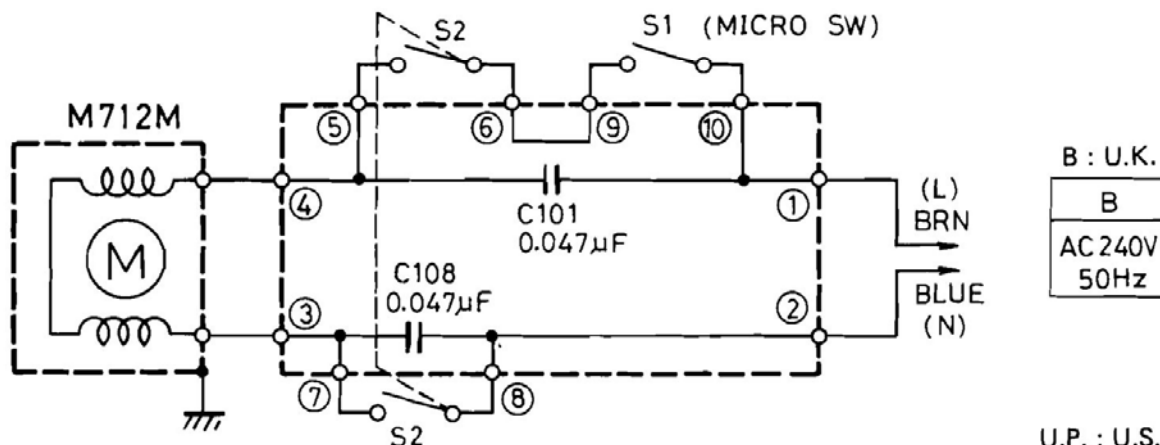
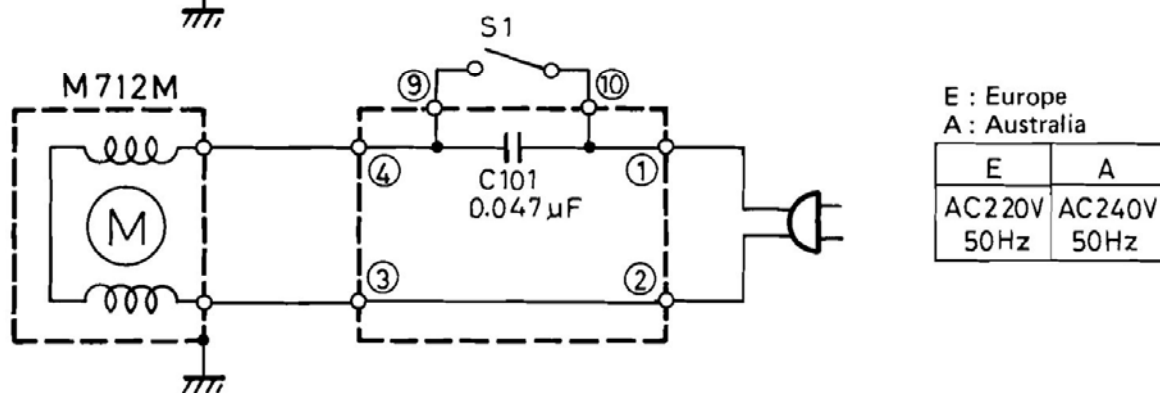
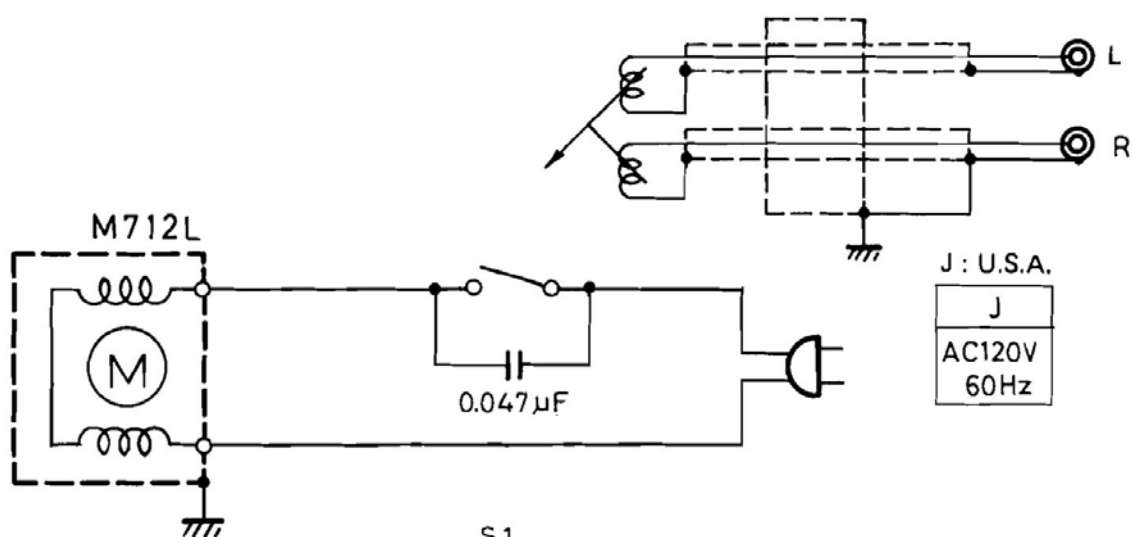

Fig. 21

JVC

VICTOR COMPANY OF JAPAN, LIMITED, TOKYO, JAPAN



Printed in Japan
— 5311 — 0 —